

Durham E-Theses

A study of the reactions between halamines and varieties of phosphorus species

Khabbass, Nabil Deeb A. H.

How to cite:

Khabbass, Nabil Deeb A. H. (1981) *A study of the reactions between halamines and varieties of phosphorus species*, Durham theses, Durham University. Available at Durham E-Theses Online: <http://etheses.dur.ac.uk/7535/>

Use policy

The full-text may be used and/or reproduced, and given to third parties in any format or medium, without prior permission or charge, for personal research or study, educational, or not-for-profit purposes provided that:

- a full bibliographic reference is made to the original source
- a [link](#) is made to the metadata record in Durham E-Theses
- the full-text is not changed in any way

The full-text must not be sold in any format or medium without the formal permission of the copyright holders.

Please consult the [full Durham E-Theses policy](#) for further details.

A STUDY OF THE REACTIONS BETWEEN
HALAMINES AND VARIETIES OF PHOSPHORUS SPECIES

by

NABIL DEEB. A.H. KHABBASS,
B.Sc. Kuwait University
M.Sc. Dunelm Graduate Society

A thesis submitted in part fulfilment of the requirements
for the degree of Doctor of Philosophy in the University
of Durham

July 1981

The copyright of this thesis rests with the author.
No quotation from it should be published without
his prior written consent and information derived
from it should be acknowledged.



To My Parents

with all the love in the world

ACKNOWLEDGEMENTS

The author wishes to thank Dr. C.J. Ludman for his supervision, advice and encouragement throughout the course of the work. The author also appreciated very much the assistance provided by members of the department especially Dr. K.B. Dillon and Dr. A. Royston. Thanks due to the technical staff. Thanks are also due to my friends for their encouragement: Dr. A. Platt and Messrs. B. Hall, I.B. Gorrell and N.R.M. Smith also to Mrs. Marion Wilson for typing this script.

My very special thanks and gratitude are due to my parents for their love and support to me through my academic career.

PREFACE

The work described in this thesis is original, except in those portions where it is specifically stated to the contrary. It has not been submitted, either wholly, or in part, for a degree at this, or at any other university.

Nabil D. Khabbass

Abstract

In this work the oxidation of various low-valent phosphorus species with halomines and halogens has been studied. ^{31}P nuclear magnetic resonance spectroscopy has been used to follow the reactions, and the pairwise additivity rule has been tested to determine if it is possible to predict the chemical shifts of the new species prepared.

The reaction of Me_2NX ($\text{X} = \text{Cl}$ or Br) with a number of phosphorus(III) species produced the phosphonium salt of the corresponding halide by simple amination at the phosphorus atom. This reaction occurred for $(\text{Me}_2\text{N})_n\text{PX}_{(3-n)}$, ($\text{X} = \text{F}, \text{Cl}, \text{Br}$ and $n = 1, 2$) except for Me_2NPF_2 ; for $\text{Ph}_n\text{PR}_{(3-n)}$ ($\text{R} = \text{Me}, \text{C}_6\text{H}_{11}, \text{Me}_2\text{N}$, and $n = 0-3$) except for $(\text{Me}_2\text{N})_3\text{P}$; and for the species Me_2PCl , MePCl_2 , $(\text{C}_6\text{H}_{11})_2\text{PCl}$ and $\text{Bu}_3^{\text{n}}\text{P}$.

The fluorine containing phosphorus species studied, where there was more than one fluorine on the phosphorus (PF_3 and Me_2NPF_2), gave more complex reactions which probably occurred due to rearrangement of the initially formed phosphorus(V) species. The overall stoichiometry of one such reaction was found to be:

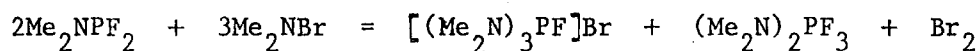

In the case of $(\text{Me}_2\text{N})_3\text{P}$ halogenation was found to occur with formation of tetramethylhydrazene.

Reaction of dimethylchloramine and dimethyl bromamine with phosphorus(III) species containing the MeO group ($(\text{MeO})_n\text{PX}_{(3-n)}$, $\text{X} = \text{Cl}$ or Ph and $n = 1-3$) may well have formed a phosphonium salt but the observed products were the halomethane and a phosphorus(V) species contain a P=O bond, e.g. $(\text{MeO})_3\text{P} + \text{Me}_2\text{NBr} = \text{Me}_2\text{NPO}(\text{OMe})_2 + \text{MeBr}$. In the case of the aryl and thioesters studied ($(\text{MeS})_3\text{P}$ and $(\text{PhO})_3\text{P}$) the intermediate species are observed.

The species studied which contained P-I and P-P bonds (PI_3 , P_2I_4 and P_4) were all oxidised by the two halomines used with the eventual loss of all such bonds and the formation of the expected phosphonium salts.

In order to assist in the confirmation of the products of some of the above reactions, the halogenations of various phosphorus(III) species were studied. These were the reactions of iodine with $(Me_2N)_3P$ and Me_2NPBr_2 , the reactions of chlorine with $(Me_2N)_2PPh$ and Me_2NPPh_2 and the reactions of bromine with the above four species and $(Me_2N)_2PBr$. In all these cases addition of one mole of halogen to one mole of the phosphorus(III) species occurred to produce the expected phosphonium salts.

CONTENTS

	<u>Page No.</u>
CHAPTER ONE - <u>INTRODUCTION</u>	1
1.1 Introduction	2
1.2 Halamines as aminating agents	3
1.2.1 Amination on the phosphorus atom	3
1.2.2 Amination on the nitrogen atom	5
1.2.3 Amination on the sulphur atom	7
1.2.4 Amination on the arsenic atom	8
1.2.5 Amination on antimony atoms	8
1.3 Halamines as halogenating agents	8
1.4 Halamines as halaminating agents	9
1.5 Decomposition reactions	10
1.5.1 Dehydrohalogenation	11
1.5.2 Disproportionation	11
1.5.3 Self halogenation	12
1.5.4 Photolysis	12
1.6 Halamines as oxidising agents by the abstraction of the hydrogen atom	13
CHAPTER TWO - <u>EXPERIMENTAL METHODS</u>	14
2.1 Introduction	15
2.2 The Vacuum Line	15
2.3 Vessels associated with the vacuum line	18
2.3.1 The reaction vessel	18
2.3.2 Ampoule breakers	19
2.3.3 The "Rotaflo" Storage Ampoule	19
2.4 The drybox	20
2.5 The ^{31}P nmr magnetic resonance spectrometer	21
2.6 Vibrational spectra	22

	<u>Page No.</u>
2.7 Analyses	22
2.8 Solvents	23
2.9 Preparation of halamines	23
2.9.1 Dimethylchloramine	23
2.9.2 Dimethylbromamine	25
2.9.3 Methyldichloramine	25
2.9.4 Methylchloramine	26
2.9.5 Dimethyliodamine	27
2.10 The preparation of phosphines	27
2.11 Other phosphorus compounds used	29
2.12 Other chemicals	30
2.12.1 Dimethylamine	30
2.12.2 Hydrogen chloride	30
2.12.3 Chlorine	30
2.12.4 Boron trichloride and boron tribromide	30
2.12.5 Other standard items of stock chemicals	30
CHAPTER THREE - <u>THE REACTIONS OF HALAMINES WITH A VARIETY OF PHOSPHITES</u>	 37
3.1 Introduction	38
3.2 The reaction between triphenylphosphite and dimethylbromamine	40
3.3 The reaction between trimethylphosphite and dimethylbromamine	41
3.4 The preparation of tris(thiomethoxy)phosphine	42
3.5 The reaction between dimethyl chloramine and tris(thiomethoxy)phosphine	42
3.6 The reaction between dimethyl bromamine and tris(thiomethoxy)phosphine	43
3.7 The reaction between dimethylchloramine and bis(methoxy)phenyl phosphine	45
3.8 The reaction between dimethyl bromamine and bis(methoxy)phenyl phosphine	45

3.9	The reaction between methoxy diphenyl phosphine and dimethyl chloramine	46
3.10	The reaction between methoxy diphenyl phosphine and dimethyl bromamine	47
3.11	The preparation of bis(methoxy)chloro phosphine	48
3.12	The reaction between bis(methoxy)chloro phosphine and dimethyl chloramine	49
3.13	The reaction between bis(methoxy)chloro phosphine and dimethyl bromamine	49
3.14	The reaction between methoxy dichloro phosphine and dimethyl chloramine	50
3.15	The reaction between methoxydichloro phosphine and dimethyl bromamine	51
3.16	Results and Discussion	52
CHAPTER FOUR - <u>THE HALOGENATION OF A VARIETY OF P-N PHOSPHINES</u>		55
4.1	Introduction	56
4.2	The preparation of dimethylamino diphenyl phosphine	58
4.3	The chlorination of diphenyl dimethylamino phosphine	59
4.4	The bromination of diphenyl dimethylamino phosphine	60
4.5	The chlorination of phenyl bis(dimethylamino) phosphine	61
4.6	The bromination of phenyl bis(dimethylamino) phosphine	63
4.7	The preparation of dimethylamino dibromo phosphine and bis(dimethylamino)bromo phosphine	64
4.8	The bromination of dimethylamino dibromo phosphine	66
4.9	The bromination of bis(dimethylamino)bromo phosphine	67
4.10	The bromination of tris(dimethylamino)phosphine	68
4.11	The iodination of tris(dimethylamino)phosphine	69
4.12	The iodination of dimethylamino dibromophosphine	70
4.13	The reaction between phosphorus trichloride and methylchloramine	71
4.14	Results and Discussion	72

CHAPTER FIVE - <u>THE REACTIONS OF HALAMINES WITH</u> <u>THE PHOSPHORUS TRIHALIDES</u>	75
5.1 Introduction	76
5.2 The reaction of phosphorus trichloride with excess dimethyl chloramine	76
5.3 The reaction between phosphorus trichloride and $\text{Me}_2\text{NPCl}_3^+$	78
5.4 The reaction between phosphorus tribromide and dimethylbromamine	78
5.5 The reaction between phosphorus tribromide and dimethylchloramine	80
5.6 The reaction between $\text{Me}_2\text{NPClBr}_3$ and boron- tribromide	81
5.7 The reaction between $\text{Me}_2\text{NPClBr}_3$ and phosphorus pentachloride	81
5.8 The reaction between phosphorus trichloride and dimethylbromamine	83
5.9 The preparation of phosphorus trifluoride	84
5.10 The reaction between phosphorus trifluoride and dimethylchloramine	85
5.11 The reaction between phosphorus trifluoride and dimethylbromamine	86
5.12 The preparation of phosphorus triiodide	87
5.13 The reaction between phosphorus triiodide and dimethylchloramine	87
5.14 The reaction between phosphorus triiodide and dimethylbromamine	88
5.15 The reaction between tetraiodobiphosphine and dimethylchloramine	89
5.16 The reaction between tetraiodobiphosphine and dimethylbromamine	89
5.17 Discussion of the reactions described in Sections 5.13, 5.14, 5.15 and 5.16	94
5.18 Discussions of the reactions	100

CHAPTER SIX - <u>THE REACTIONS OF HALAMINES WITH A VARIETY OF ORGANO HALO SUBSTITUTED PHOSPHINES</u>	103
6.1 Introduction	104
6.2 The reaction between dimethylchlorophosphine and dimethylchloramine	104
6.3 The reaction between dimethylchlorophosphine and dimethylbromamine	105
6.4 The reaction between methyl dichlorophosphine and dimethylchloramine	106
6.5 The reaction between methyl dichlorophosphine and dimethylbromamine	107
6.6 The reaction between dicyclohexyl chloro phosphine and dimethyl chloramine	109
6.7 The reaction between dicyclohexyl chloro phosphine and dimethyl bromamine	110
6.8 The reaction between bis(dimethylamino)chloro phosphine and dimethyl bromamine	111
6.9 The reaction between dimethylamino dichloro phosphine and dimethyl bromamine	112
6.10 The reaction between bis(dimethylamino)bromo phosphine with dimethyl bromamine	113
6.11 The reaction between dimethylamino dibromo phosphine with dimethyl bromamine	114
6.12 The preparation of dimethylamino difluoro phosphine	115
6.13 The reaction between dimethylamino difluoro phosphine and dimethylchloramine	116
6.14 The preparation of bis(dimethylamino)fluoro phosphine	117
6.15 The reaction between bis(dimethylamino)fluoro phosphine and dimethylchloramine	118
6.16 The reaction between bis(dimethylamino)fluoro phosphine and dimethylbromamine	119
6.17 The reaction of dimethylamino difluoro phosphine with dimethyl bromamine	120
6.18 The reaction between dimethylamino dibromo phosphine and dimethyl chloramine	121
6.19 Results and Discussion	123

	<u>Page No.</u>
CHAPTER SEVEN - <u>THE REACTIONS OF HALAMINES WITH A VARIETY OF TRI(ORGANO)PHOSPHINES</u>	128
7.1 Introduction	129
7.2 The reaction between dimethylchloramine and triphenylphosphine	129
7.3 The reaction between triphenyl dimethylamino phosphonium chloride and boron trichloride	130
7.4 The hydrolysis of triphenyl dimethylamino phosphonium chloride	131
7.5 The reaction between triphenyl phosphine and dimethyl bromamine	132
7.6 The reaction between triphenyl dimethylamino phosphonium bromide and boron tribromide	133
7.7 The hydrolysis of triphenyl dimethylamino phosphonium bromide	134
7.8 The reaction between tri(n-butyl)phosphine and dimethyl chloramine	134
7.9 The reaction between tri(n-butyl)phosphine and dimethyl bromamine	135
7.10 The hydrolysis of tri(n-butyl) dimethylamino phosphonium halide	136
7.11 The reactish between trimethyl phosphine and dimethylchloramine	137
7.12 The reaction between trimethyl phosphine and dimethyl bromamine	138
7.13 The hydrolysis of trimethyl dimethylamino phosphonium halide	139
7.14 The reaction between tricyclohexyl phosphine and dimethyl chloramine	139
7.15 The preparation of tris(dimethylamino)phosphine	141
7.16 The reaction between tris(dimethylamino) phosphine and dimethylbromamine	142
7.17 Results and Discussion	144

CHAPTER EIGHT - <u>THE REACTIONS OF HALAMINES WITH A VARIETY OF ORGANO PHOSPHINES</u>	146
8.1 Introduction	147
8.2 The reaction between diphenylmethylphosphine and dimethylchloramine	147
8.3 The reaction between diphenylmethylphosphine and dimethylbromamine	148
8.4 The preparation of dicyclohexyl phenyl phosphine and cyclohexyl diphenyl phosphine	149
8.5 The reaction between diphenylcyclohexylphosphine and dimethylchloramine	151
8.6 The reaction between diphenylcyclohexylphosphine and dimethylbromamine	152
8.7 The reaction between phenyldicyclohexylphosphine and dimethylchloramine	153
8.8 The reaction between phenyldicyclohexylphosphine and dimethylbromamine	154
8.9 The reaction between bis(dimethylamino)phenyl phosphine and dimethylchloramine	156
8.10 The reaction between bis(dimethylamino)phenyl phosphine and dimethylbromamine	157
8.11 The reaction between dimethylamino diphenyl phosphine and dimethylchloramine	158
8.12 The reaction between dimethylamino diphenyl phosphine and dimethylbromamine	159
8.13 The reaction between dimethylphenylphosphine and dimethylchloramine	160
8.14 The reaction between dimethylphenylphosphine and dimethylbromamine	161
8.15 The reaction between excess white phosphorus and dimethylchloramine	162
8.16 The reaction between white phosphorus and excess dimethylchloramine	162
8.17 Results and Discussions	164

CHAPTER NINE - <u>THE EFFECT OF LIQUID HYDROGEN CHLORIDE ON A VARIETY OF P-N PHOSPHONIUM SALTS</u>	166
9.1 Introduction	167
9.2 The purification of hydrogen chloride	167
9.3 The reaction between liquid hydrogen chloride and dimethylamino triphenyl phosphonium chloride	168
9.4 The reaction between liquid hydrogen chloride and bis(dimethylamino)diphenyl phosphonium chloride	169
9.5 The reaction between tris(dimethylamino)phenyl phosphonium chloride and liquid hydrogen chloride	170
9.6 The reaction between tris(dimethylamino)chloro phosphonium chloride with liquid hydrogen chloride	171
9.7 The reaction between hexamethylphosphoramide and liquid hydrogen chloride	172
9.8 The reaction between bis(dimethylamino)dichloro phosphonium chloride and liquid hydrogen chloride	173
9.9 The reaction between trimethyl dimethylamino phosphonium chloride and liquid hydrogen chloride	174
9.10 The reaction between dimethylamino dimethyl phosphonium chloride and liquid hydrogen chloride	175
9.11 The reaction between dimethylamino methyl dichloro phosphonium chloride and liquid hydrogen chloride	175
9.12 The reaction between tris(methoxy)phosphine oxide and liquid hydrogen chloride	176
9.13 Results and Discussion	177
CHAPTER TEN - <u>THE PREDICTION OF THE CHEMICAL SHIFTS FOR A VARIETY OF PHOSPHONIUM IONS</u>	180
10.1 Introduction	181
10.2 The prediction of the chemical shift of phenyl chloro substituted phosphonium ions	182

10.3	The prediction of the chemical shift for some $[\text{Me}_n\text{PCl}_{(4-n)}]^+$ cations	183
10.4	The prediction of the chemical shift for $\text{PhPNMe}_2\text{Me}_2^+$	183
10.5	The prediction of the chemical shift for $(\text{Me}_2\text{N})_3\text{PCl}^+$	184
10.6	The prediction of the chemical shift for $\text{Me}_3\text{PNMe}_2^+$ and $\text{MePNMe}_2\text{Cl}_2^+$	185
10.7	The prediction of the chemical shift for $\text{PhPNMe}_2\text{Cl}_2^+$ and $\text{Ph}_2\text{PNMe}_2\text{Cl}^+$	187
10.8	Conclusion	188
APPENDICES		189
	Appendix I - I.R. Spectra	
	Appendix II - N.M.R. Spectra	
	Appendix III 1 Departmental Colloquia	207
REFERENCES		216

CHAPTER ONE

INTRODUCTION



1.1 Introduction

The interest in the present work has arisen from studies done in this laboratory on the reactions of dimethylchloramine and phosphorus trichloride (1). The reaction in the presence of excess phosphorus trichloride was found to correspond to the equation:



In this work the reaction mentioned above has been further studied and also the reactions of dimethylchloramine and dimethylbromamine with the other three phosphorus trihalides.

(24)

H.H. Sisler and his co-workers had previously carried out several reactions between N-halamines and tricoordinate phosphorus compounds. They found that all these reactions were simple amination on the phosphorus atom except the reaction between dimethylchloramine and tris(dimethylamino) phosphine in which the phosphine was chlorinated. In order to extend Sisler's work and to throw some light on the phosphorus trichloride reactions mentioned above, a study of the reactions of dimethylhalamines with a variety of phosphorus III species was undertaken.

In the work of Patrova and Sokol'skii (2) dimethylchloramine had been reacted with a variety of phosphite esters and the expected phosphonium ions were not formed, but could have been produced as intermediates. This work has been extended to isolate the intermediate species and to rationalize the mechanisms.

In a parallel study to the oxidation of phosphorus III species by halamines, the reactions of halogens and hydrogen

chloride on these species and phosphonium salts was undertaken, partly in order to help to confirm the assignments of some of the ^{31}P nmr shifts. Chlorine was found to oxidise and in some cases cleave the P-N bond.

The products formed in this work were studied by analysis and a variety of physical technique, but the most important technique used to follow the reactions was ^{31}P nmr spectroscopy. Some of the compounds made in this study are new and many of them have not had their ^{31}P nmr chemical shift reported. Consequently an attempt was made to correlate the chemical shift found with the structures of the various species.

From the above discussion it would be helpful if the various ways in which the halamines have been found to react was categorised. Consequently the reactions of halamines are divided into the following sections:

1. Aminating agents
2. Halogenating agents
3. Halaminating agents
4. Decomposition
5. Oxidising agents by the hydrogen atom abstraction.

1.2 Halamines as aminating agents

1.2.1 Amination on the phosphorus atom:

N-halamines react as aminating agents towards several species of phosphorus III compounds. Some typical examples are given below:

When an arylphosphite is treated with R_2NCl

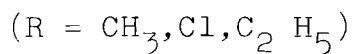

an addition compound is generated by simple amination on the phosphorus atom:

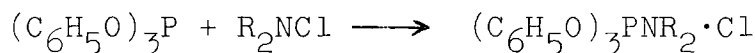

The ionic nature of $(C_6H_5O)_3PNMe_2 \cdot Cl$ has been confirmed by ^{31}P nmr (1). When $(C_6H_5O)_3PNEt_2 \cdot Cl$ is heated vigorously $EtCl$ is generated:

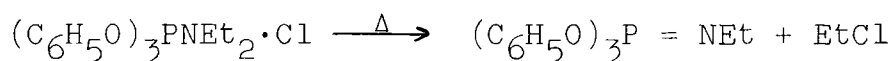

The expected phosphonium salts were not produced when an alkylphosphine was treated with N-halamines (2), but they may be produced as intermediates:

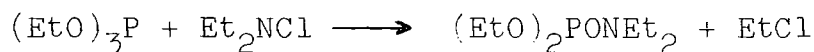

When alkylphosphines react with chloramine, phosphonium salts are produced in high yield which in some cases are difficult to isolate because of facile hydrolysis (3):

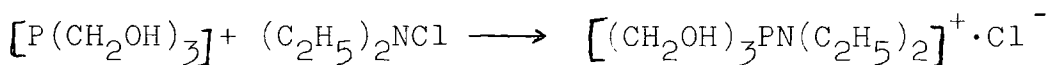
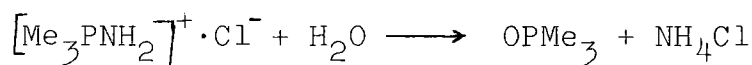
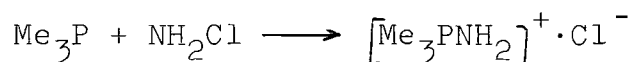

In previous work done in this laboratory by Khabbass (1) the reaction of dimethylchloramine and excess phosphorus trichloride has been studied and the stoichiometry of this reaction has been shown to be:

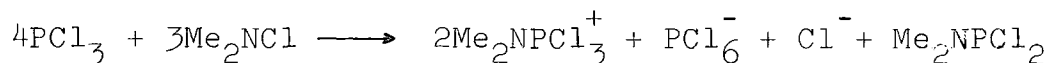

Although the above rather complex reaction occurs with PCl_3 , with substituted phosphorus chlorine species simple amination occurs (1):

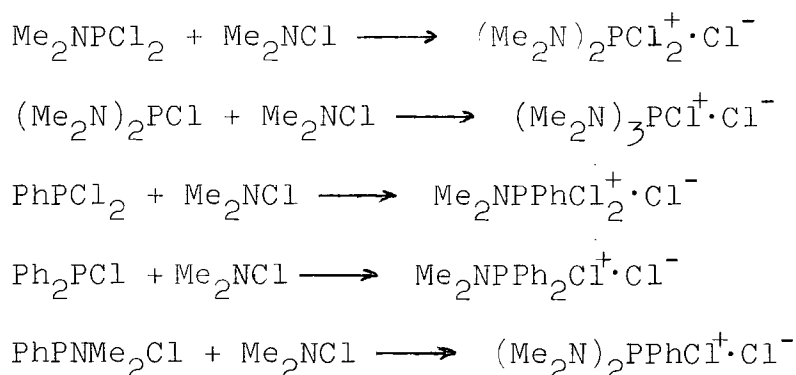

Dimethylchloramine behaves in a similar way and produces the corresponding phosphonium salts (4) when reacted with Me_2NPMe_2 and $(\text{Me}_2\text{N})_2\text{PMe}$:

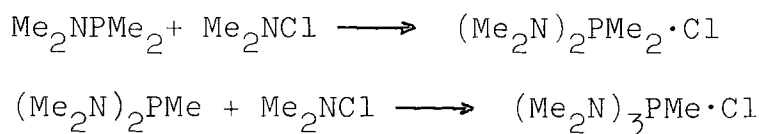

Simple amination occurs when chloramine reacts with an aminophosphine (5,6) or a hydrazinophosphine (7):

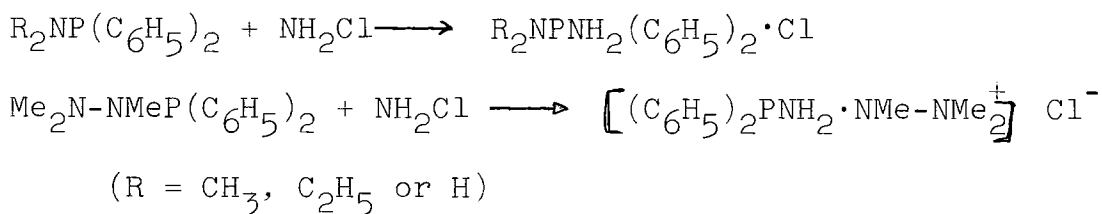

It was found that N,N-dihalogeno-S,S-dimethyl sulphur diimide with phosphine (8) as follows:

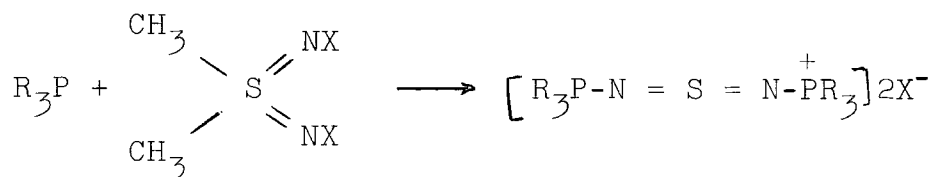

1.2.2 Amination at a nitrogen atom:

A review by Drago (9) listed reactions in which hydrazines can be synthesised by the reaction of chloramine

with amines as shown in the following equations:

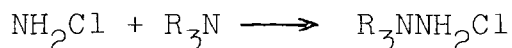
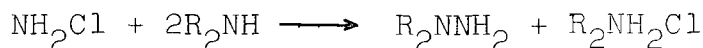
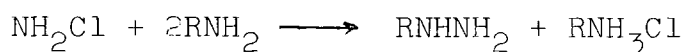

The reactions between formaldehyde in 2N sodiumhydroxide and alkylamines with hypochlorite (10) produce diaziridines:

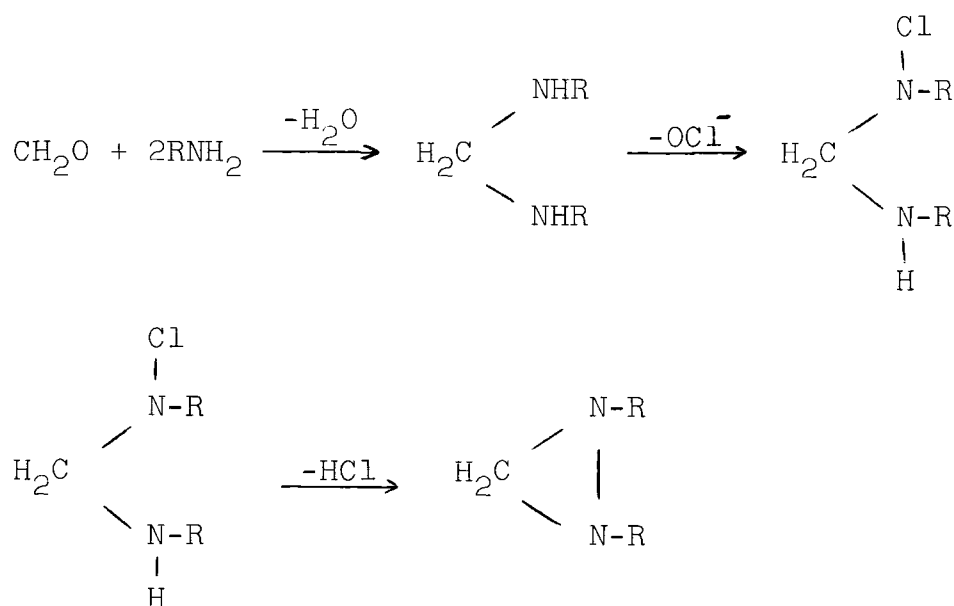

A gaseous mixture of ammonia and chloramine with 1,1-dialkylhydrazine (11) generated triazanium salt as shown by the following equation:

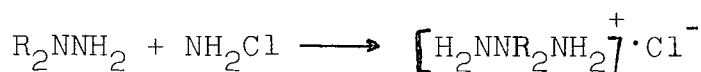

Chloramine reacts with α -pyridone in the presence of a base to form a hydrazine derivative (12) as shown in the following equation:

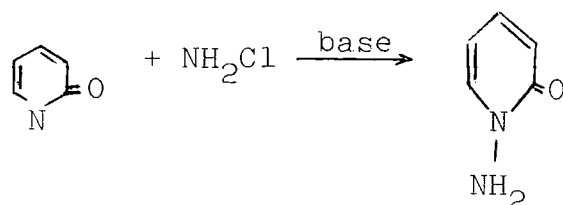

A mixture of formaldehyde oxime and chloramine generates diazomethane in a sequence of steps commencing with nucleophilic displacement taking place on the nitrogen of chloramine (13) as shown in the following:

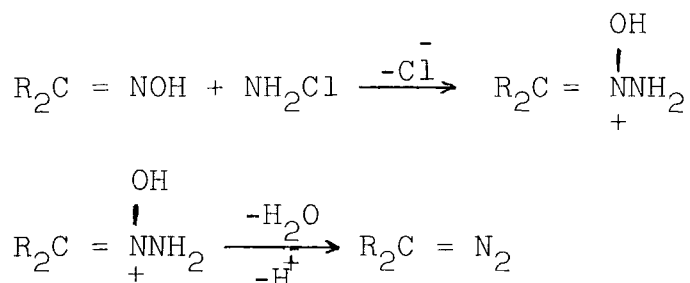

1.2.3 Amination at sulphur atoms:

It was shown that dialkylsulphonium amino chloride precipitated when dialkyl sulphides were treated with chloramine in ether solution (14):

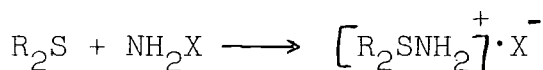

In alcoholic solvents sulphides react with chloramine (15) as follows:

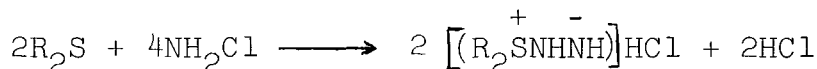

Nitrogen trichloride reacts with diphenyl sulphide to generate bis(diphenyl sulphide) nitride trichloride (16) as indicated in the following equation:

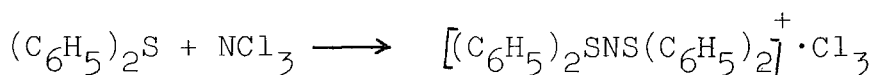

Bock and Kompa (17) generated various thiocyanates according to the following general reaction:

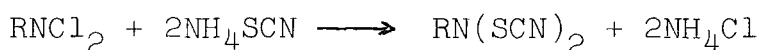

The reaction of N-halamines with sulphur compounds has not been extensively studied. The most common process appears to be nucleophilic substitution on the halamine nitrogen by

sulphur compounds; for example the reaction of N-monochloro derivatives of primary amines with metal mercaptides (18), which generate sulphinetriazine as a new ring compound (19):

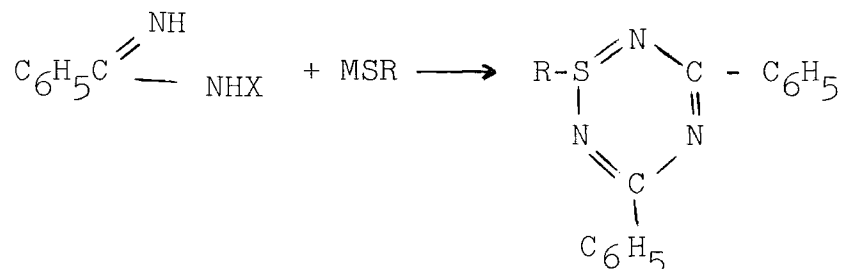

1.2.4 Amination on arsenic atoms:

Diphenylarsine and triphenylarsine react with chloramine to give aminoarsonium chlorides (20) as follows:

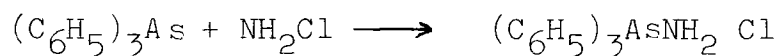

The fission of some arsenic-phenyl bonds with the production of chlorobenzene in the chloramination of phenylarsine was observed under some conditions (21).

1.2.5 Amination on antimony atoms:

Various substituted stibines combine with chloramine (20) to produce compounds of the type shown below:

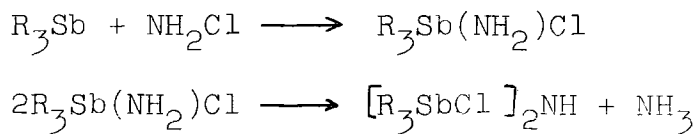

1.3 Halamines as halogenating agents

Nitrogen trichloride has been shown to be an important reagent for the preparation of vic-dichlorides in very high yield from certain types of olefins (22):

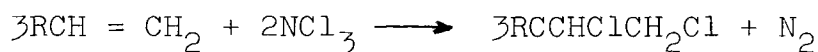

It was found that acetylenes undergo chlorination with nitrogen trichloride to give predominantly vic-dichloroalkenes.

Tris(dimethylamino)phosphine $(\text{Me}_2\text{N})_3\text{P}$ was chlorinated by chloramine (24,1). Sisler and his co-workers proved the formation of $(\text{Me}_2\text{N})_3\text{PCl}_2$ and suggested that the other product was tetramethylhydrazine as deduced from the stoichiometry of the reaction, however they did not isolate any of the hydrazine. The reaction was repeated in this laboratory under different circumstances and the formation of $(\text{Me}_2\text{N})_3\text{PCl}_2$ was found. The formation of tetramethylhydrazine was confirmed by the gas phase infrared spectrum (1):

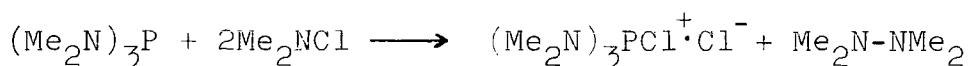

Phenylphosphine and diphenylphosphine did not give the expected phosphonium salts when they were treated with dimethylchloramine (24). This is due to the decomposition of the initially formed phosphonium salts as shown by the following equations:

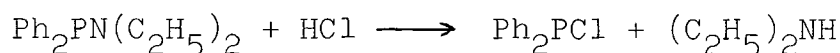
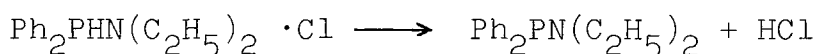
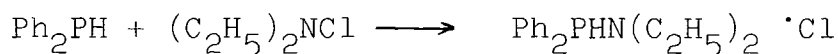

1.4 Halamines as halaminating agents

Nitrogen trichloride (25) oxidizes diphenylketene by halamination:

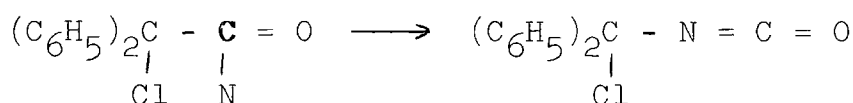
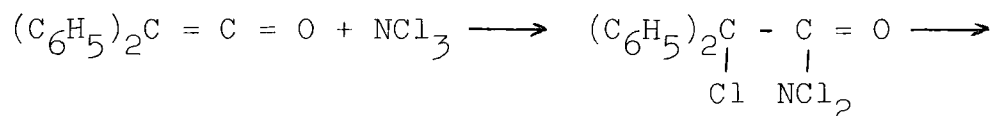

The reactions of aldehydes and ketones with chloramines represent an interesting study since the ald-chlorimines

are examples of the Schiff base reaction (26) as shown by the following equation:

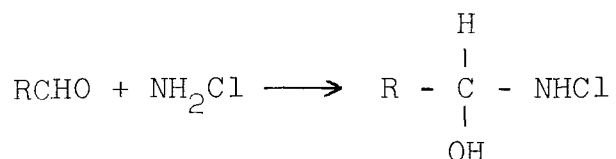

R.S. Neale found that allenes undergo 1,2-radical addition with N-chlorodialkylamine in sulphuric acid-acetic acid medium. Aminium radical attack results in nitrogen becoming affixed to the least substituted carbon atom. An example of this is the reaction between diethylchloramine and allene producing 2-chloroallylamines (27,28) as indicated below:

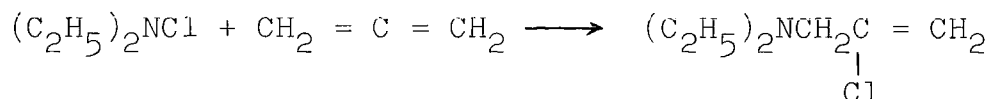

Phosphorus trichloride reacts with nitrogen trichloride in the presence of a solvent to give pale greenish-yellow crystals of $\text{P}_3\text{NCl}_{12}$ (29) as shown by the following equation:

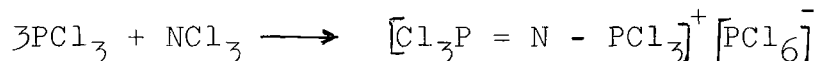

When phenyl dichlorophosphine was reacted with nitrogen trichloride in chloroform, compound (1) was produced (in 20% yield) with $\text{C}_6\text{H}_5\text{PCl}_4$ (30)

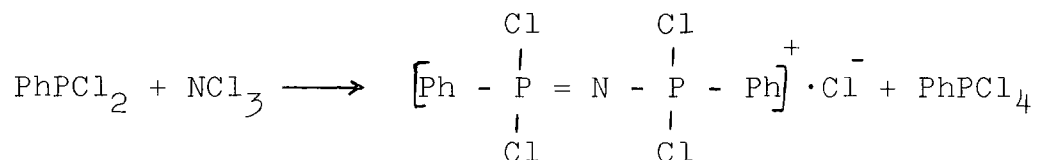

1.5 Decomposition reactions

Decomposition reaction can be classified into four categories:

1. Dehydrohalogenation; 2. Disproportionation;
3. Self halogenation; 4. Photolysis.

1.5.1 Dehydrohalogenation:

It has been found that N-halamines with α -hydrogen atoms are susceptible to dehydrohalogenation by caesium fluoride in refluxing acetonitrile giving a nitrile, the yield was reported to be 90% (31). Typical examples are:

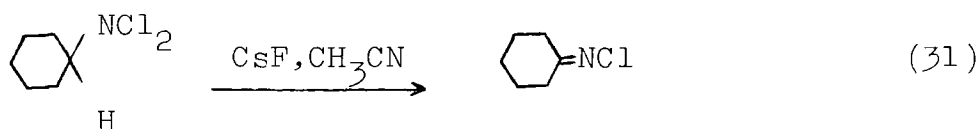
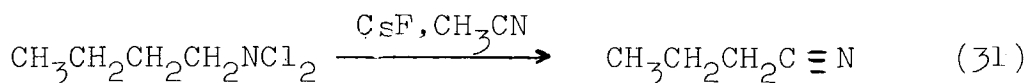

Nitriles are formed from ald-chlorimines as shown by the following equation by thermal decomposition or exposure to base:

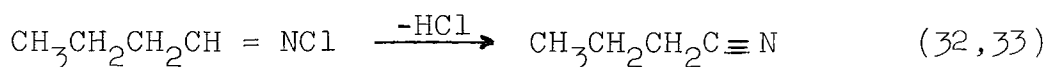

1.5.2 Disproportionation:

When N,N-dichlorotriphenylmethyamine was heated to 132°C an explosion occurred and the characteristic crystals of benzophenone were obtained (34, 35):

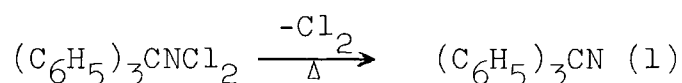

Compound (1) rearranged to produce the ketamine which hydrolysed to benzophenone:

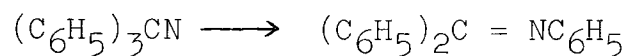

J. Jander and C. Lafrenz found that methylbromamine tended to be found in equilibrium with methyldibromamine and methylamine (36):

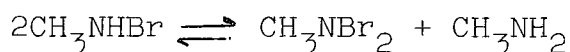

1.5.3 Self halogenation:

Due to the Hofman-Loeffler N-chloramine rearrangement, the reaction pathway (suggested) indicated self chlorination (37) of the protonated N-chlorodibutylamine, in the presence of an aqueous solution of sulphuric acid

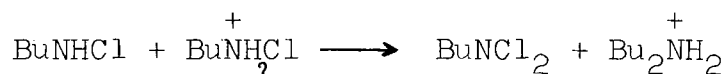
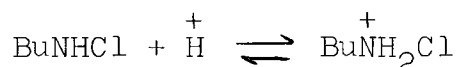

1.5.4 Photolysis:

The photochemistry of N-halamines has not been studied extensively and it has been concerned with simple molecules such as chloramine and nitrogen trichloride. The photolysis of chloramine at -190°C with ultraviolet light generated NH (38) which was proposed as an intermediate in the thermal decomposition of NH_2Cl at 500°C in the presence of carbon monoxide in which hydrogen cyanate was produced. An extensive study of the photodecomposition of nitrogen trichloride in the presence of chlorine established that chlorine was acting as photosensitizer (39,40) and that the following chain mechanism was occurring:

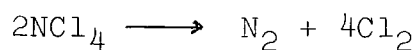
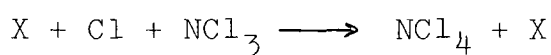
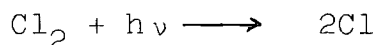

1.6 Halamines as oxidising agents by the abstraction of the hydrogen atom

The following equations show the reactions between NH_2Cl , Me_2NCl and arsines containing As-H bonds (41):

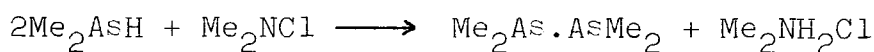
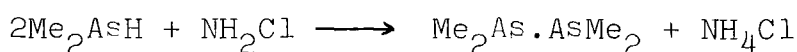
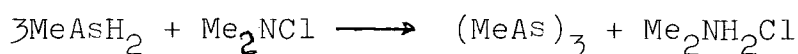
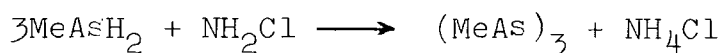
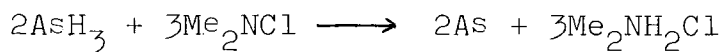
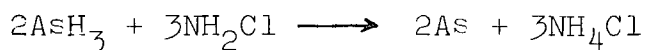

Similar results were obtained when phosphines containing P-H bond were reacted with R_2NCl ($\text{R} = \text{Me}$ or H) (42) as shown by the following equations:



Polymeric phosphorus hydrides were obtained when phenyl phosphines were treated with chloramine

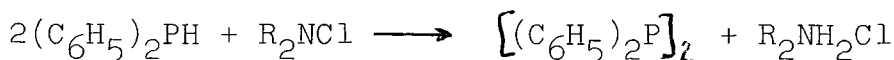

CHAPTER TWO

EXPERIMENTAL METHODS

2.1 Introduction

The study of the reactions of various phosphines with a variety of halamines required the use of a number of manipulative techniques. The liquid halamines as well as some of the phosphines used in this study were very volatile substances. The vacuum line allowed quantitative transference to be made under anhydrous conditions and it was also useful in the identification, removal and purification of the volatile substances formed in the reactions studied. In this chapter the vacuum line, drybox, Pnmr equipment and associated apparatus will be described. The methods employed to prepare and purify the reactants used in this study are also included.

2.2 The vacuum line

The vacuum line described previously (1) was used to perform some of the reactions in the present study, but in the latter part of this study a rather simpler version was used (figure 2.1) which had the advantage of being easily disconnected and cleaned. This new vacuum line comprised of three sections:

1. Pumping section (P)
2. General working section (W)
3. Fractionating section (F)

The pumping section contained a Jencons mercury diffusion pump backed by an Edwards two stage rotary oil pump. The diffusion pump capacity was better than 30 litres per second at 10^{-3} to 10^{-5} mm/Hg. This pump was heated electrically using a 320 watt wrap around heating element. The critical backing pressure of 0.2 mm/Hg was easily obtained using the

two stage rotary oil pump. This provided a pumping speed of 22 litres per minute and optimum vacuum better than 10^{-3} mm/Hg. The diffusion pump was placed between the rotary oil pump and a cold trap and could be isolated from them by two taps (2a and 3a, figure 2.1). An air bleed via tap 1a was included and as a further precaution against suck-back of pump oil the device shown in figure 2.5 was introduced in the hose connection to the oil pump. The connections between the rotary pump and the diffusion pump and the rest of the line were as large as was convenient.

The general working section consisted of a row of three taps terminating in B14 sockets to facilitate the attachment of various pieces of apparatus such as an infrared gas cell. It was found more satisfactory to use B14 sockets rather than B14 cones as reactions were performed which often required the making and breaking of the connections of this part of the line, e.g. the reaction cell (figure 2.3), where the removal of the vacuum grease from the detached apparatus was made more convenient by having a cone and not a socket. This section was equipped with a Vacustat (a simple type of Mcleod gauge which can measure pressure down to 10^{-5} mm/Hg).

The fractionating section was used for the purification of volatile chemical substances. This section comprised of three individually isolatable traps of a diameter making a close fit to the mouth of a "Thermos" dewar. Access to this section was via B14 sockets. Cold baths necessary for fractional condensation were made up using organic liquids of suitable melting points cooled to their freezing temperature using liquid nitrogen; or solid carbon dioxide mixed with a suitable solvent. The temperature of these baths are given in table 2.1.

Table 2.1

Low Temperature Baths

Solvent	Approximate Temperatures °C
Melting carbon tetrachloride	-23.0
Melting chlorobenzene	-45.0
Solid carbon dioxide with acetone	-83.0
Melting toluene	-96.0
Melting carbon disulphide	-112.5
Melting n-pentane	-131.0

The cold trap used in the pumping section was cooled in liquid nitrogen. The dewars used with the vacuum line were either standard wide-necked dewars or one litre "Thermos" flasks. The latter were predominantly for freezing very volatile purified products to liquid nitrogen temperatures on the fraction train when such products could not be stored elsewhere (such as HCl and PF₃). Because the nitrogen evaporation rate was minimised by the narrow neck of the flask, complete loss of liquid nitrogen would take longer than 24 hours. These flasks were never used as containers for cold baths. The pressure inside the vacuum line was measured by a mercury manometer (figure 2.2a) which was of direct reading type. This U-shaped manometer was made from 10 mm bore tubing and it was fastened to a meter rule. The rule was fixed to a vertical wooden board. The manometer was initially set up by evacuating it as the mercury was added from a tap funnel in the top B14 socket. When the required amount of mercury had been added the funnel was replaced by a stopper. Air was blown into the manometer until the side reservoir was filled with mercury which trapped any traces of air or moisture in the reservoir.

When the manometer was under vacuum the level of mercury was equal in both branches of the U-shaped tube; thus pressure was measured by reading the difference in the mercury levels.

A high tension coil (H.T. unit, type 1. Edwards High Vacuum Ltd.) was used in the detection of any leak caused by loose joints, pin holes in the glass, etc., by producing a discharge colour inside the vacuum line. Care was taken in its use since it could have caused pin holes if used in checking thin-walled containers such as molecular weight bulbs.

In most cases a saturated hydrocarbon grease 'M' obtained from Apiezon Limited was used for joints which were parted during manipulations. Grade 'L' of this saturated hydrocarbon grease was used for taps within the vacuum line, as it proved more convenient, since when the ambient temperature was low it remained more fluid than grade 'M' grease. Grade 'W' Apiezon grease (or black Picene wax) was used for connections at the diffusion pump since this would withstand the high temperature in this area. For experiments involving substances reactive towards the saturated hydrocarbon grease, such as chlorine, Kel-F 90, a fully fluorinated grease was used.

2.3 Vessels associated with the vacuum line

2.3.1 The reaction vessel:

The reaction vessel (figure 2.2b) was formed from a B24 cone and socket, the latter being connected to a ground glass tap which terminated in a B14 cone by which the cell could be attached to the vacuum line by means of a suitable 'L' shaped adaptor. This vessel's advantage is that with careful greasing materials can be weighed without coming

into contact with air. This reaction vessel was found to be better than using greaseless Rotaflo taps (figure 2.2c) when it was required to store materials at the freezer temperature (-30°C) since the PTFE plug of the Rotaflo type stopcock was found to leak considerably at this temperature due to contraction.

2.3.2 Ampoule breakers:

For the opening of 16mm diameter heavy walled pyrex reaction ampoules, an ampoule breaker (figure 2.3) was used. This was used by initially deeply scoring the sealed end of the ampoule, and coating the 6mm O.D. diameter neck of the ampoule with Apiezon-W wax. Whilst the wax was still soft, the open end of the ampoule breaker was slid on to the ampoule so that the scored end was close to the heavy eccentric lever of the ampoule breaker. Visual inspection usually revealed if the seal was adequate since the wax "wetted" the inside of the breaker tube. The complete breaker and ampoule was then fixed to the vacuum line *via* its Bl4 cone and the breaker evacuated. The ampoule was usually frozen in liquid nitrogen before opening and the tip of the ampoule cracked off by carefully turning the eccentric lever thus bringing the arm in an arc across the tip of the ampoule as is shown in figure 2.3.

2.3.3 The "Rotaflo" Storage Ampoule:

This tube (figure 2.2c) was used to store volatile substances where boiling point is less than room temperature (such as Me_2NH) and it was used as a container for reactants of high vapour pressure at room temperature (such as BCl_3). Such ampoules were never kept in the freezer and if cooling was necessary they were cooled by a cold bath to avoid leakage

due to the contraction of the "PTFE" plug in the Rotaflo stopcock. A good seal was obtained when both the "PTFE" glass contact areas appeared "wetted". It was important to ensure that no dust particles or pieces of fibre adhered to the valve seat or the valve stem otherwise this would cause leakage.

2.4 The drybox

The drybox was of standard design of approximately 30 litres capacity and is shown along with the associated humidity control equipment in figure 2.4. The glove box was manufactured in the Science Site central workshops at Durham from an original drawing from Warwick University from $\frac{1}{8}$ -inch mild steel; all joints were welded. A tubular spanner was welded into the base to take an infrared disk press. The box was kept even when not in use, under a positive pressure of nitrogen, so that the gloves were inflated. The nitrogen used for the make-up of the box atmosphere was de-oxygenated in the department, provided from the central liquid nitrogen storage tank and rated at less than 6 p.p.m. and 10 p.p.m. O_2 and H_2O . The rate of nitrogen flow was controlled by a needle valve. The nitrogen was dried by passing through a drying tower containing phosphorus pentoxide, before entering the box. The glove box itself was kept dry with dishes of phosphorus pentoxide placed in strategic positions around the box floor. The efficiency of this method of desiccation was noted from the spectra of extremely moisture sensitive compounds. Entry to and exit from the box for large objects was *via* the main port 'A' which was purged with nitrogen for between 30 and 45 minutes depending upon the items being taken into the box, before opening the inside port. For small

items, such as ^{31}P nmr tubes, the quick entry and exit port 'Q' was used. The box was connected to a water pump 'W' *via* a cold trap 'C'. This helped in carrying out the filtration of moisture sensitive compounds inside the dry box and in pumping off solvent under vacuum. The box was also fitted with an electrical connection *via* a 13 amp socket in the side wall. All non-welded joints, for instance the large plastic window, were sealed with Silicoset silicone rubber. Before initial use the box was purged with nitrogen for at least two weeks.

2.5 The phosphorus n.m.r. spectrometer

The ^{31}P nmr spectra were recorded on a pulse spectrometer built around a Perkin Elmer R10 thermostatted permanent magnet. The necessary electronics were built in the Chemistry Department by Dr. A. Royston. Signals from the nmr probe were digitized and accumulated by a Varian 620/L computer which was controlled from the keyboard of a visual display unit (shown on page 36). Apart from performing a Fourier transform on the nmr signal, and plotting it on the R/O chart recorder, the computer also controlled the pulse programmer. This unit switched the transmitter on and off and organised all the required timing necessary for signal accumulation. Many of these spectrometer functions are controlled by the computer and spectra obtained by it can be manipulated and measured from the keyboard. All ^{31}P chemical shifts were reported with respect to 85% aqueous phosphoric acid (as 0.0 p.p.m. shift) with the upfield direction taken as positive. It was found that the phosphorus nmr spectrometer error is ± 1.4 p.p.m.

Phosphorus n.m.r. tubes of 8mm diameter were used filled with phosphorus compound, (or their solutions) to about 2cm depth. The modified phosphorus nmr tube (shown in figure 2.5) is made of 8mm diameter tube terminating with a B14 cone. This cone was fitted to a B14 socket and cone tap by which it could be attached to the vacuum line. When nmr tubes were used for sealed tube reactions, when highly volatile substances were handled (such as liquid hydrogen chloride) the tubes were made of silica with a constriction below the B14 cone, so that the tubes could be easily sealed after the volatile materials had been condensed into them.

2.6 Vibrational spectra

The infrared spectra of solids were recorded on a Perkin-Elmer 577 instrument as nujol mulls between KBr plates. The infrared spectra of liquids were obtained as a thin film. Gas phase spectra were obtained using a 10cm cell with KBr windows, which were fixed to the ground glass ends by means of Apiezon 'W' wax (figure 2.5).

2.7 Analyses

C, H and N were determined by micro combustion with a Perkin-Elmer 240 instrument. The reliability of the machine was found to be variable. Phosphorus and halogen analyses were carried out by R. Coult. For phosphorus and chlorine a weighed sample was decomposed by fusing in a nickel parr bomb. The residue was acidified with concentrated nitric acid and made up to 100cm³ with distilled water. For phosphorus a suitable aliquot was treated with ammonium molybdate/ammonium vanadate reagent and the absorbance measured at 420nm using a Unicam SP500 spectrophotometer. Chlorine was determined by potentiometric titration against N/100 silver nitrate solution using Ag/AgCl electrodes in an acetone medium.

Bromine was determined iodometrically following a Schoniger oxygen flask combustion.

2.8 Solvents

Generally solvents of the best commercially available grade were used. Chlorocarbons were dried over 4A mesh molecular sieve and stored under nitrogen. Hydrocarbon solvents were dried over sodium wire and then stored under nitrogen over freshly activated molecular sieve. Carbon disulphide was distilled from phosphorus pentoxide and stored over molecular sieve before use.

2.9 Preparation of halamines

2.9.1 Dimethylchloramine:

This substance has been prepared in the past by a variety of methods (43,44). In this work the method modified from that of Hoffman (45) was used in which dimethylammonium chloride was reacted with sodium chlorate (I):

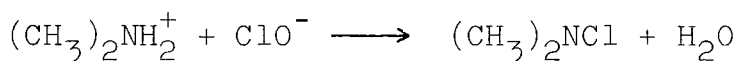

It was found to be an improvement if a very strong solution of sodium chlorate (I) was prepared just before the chlorination of the ammonium salt, and if the latter was added to the chlorate (I) solution in the solid phase in small portions.

Sodium chlorate (I) was prepared by the chlorination of a solution of sodium hydroxide as follows:

Sodium hydroxide (109g 2.7 moles) was dissolved in 150cm³ water in a wide-mouthed 3 litre conical flask. After cooling to room temperature, 625g of ice was added and chlorine passed in rapidly from a cylinder, with shaking until all but little of the ice remained unmelted by the heat of the reaction.

To this solution was added dimethylammonium chloride (82g, 1.0 mol) in small portions. The flask was well shaken during the addition and cooled externally in an ice-water bath. The dimethylchloramine separated as a pale yellow upper layer and was quickly separated by using a separating funnel. The crude dimethylchloramine was kept in the freezer, mixed with calcium chloride as drying agent at first and then with phosphorus pentoxide. Temperature control during the addition of the ammonium salt was found to be very important, since any rise favoured the formation of dichloro-derivatives and possibly highly explosive nitrogen trichloride. Dimethylchloramine was purified by fractional condensation on the vacuum line, the mixture being distilled through four traps cooled with the following slush baths, one at -23°C , two baths at -83°C and one at -196°C . The majority of the product was collected at -83°C and was shown to be pure by its gas phase infrared spectrum (figure 1). The dimethylchloramine was kept in a reaction vessel (figure 2.2b) in the freezer at -30°C , because of its decomposition at room temperature. Small pure samples of dimethylchloramine were prepared by reacting n-chlorosuccinimide with dimethylamine (46):

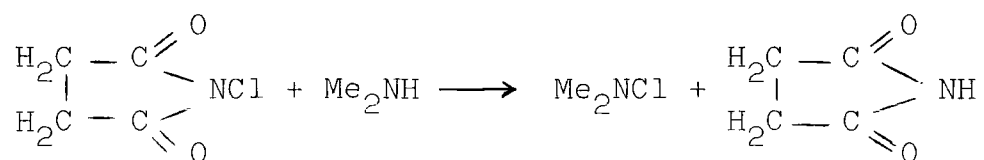

In a typical preparation of dimethylchloramine, a sample of dry dimethylamine was condensed into a calibrated cold finger (figure 2.5) at -196°C , then the amine was degassed. Dimethylamine was allowed to melt and its volume measured as 6.5 cm^3 (98.67 mmol). This was transferred on to 19g (142.38 mmol) of n-chlorosuccinimide in a 100 cm^3 flask equipped with cone tap connection. The flask was sealed

and kept at -30°C (the freezer temperature) for 24 hours, after which time the cell was returned to the vacuum line and the volatile material distilled out. The infrared spectrum showed the presence of dimethylchloramine only, (Fig. 1. ~~P. 189~~)

2.9.2 Dimethylbromamine:

In a typical preparation 22g(123.66 mmol) of N-bromosuccinimide was weighed into a 100 cm^3 conical flask equipped with a cone tap connector. The flask was placed on the vacuum line and degassed. A sample of dimethylamine dried over sodium wire was condensed into a calibrated cold finger (figure 2.5) at -196°C , it was degassed and allowed to warm up gradually until it melted. The volume of this sample was measured as 6.1 cm^3 (92.16 mmol). This was then condensed onto the solid at -196°C . The flask was isolated from the vacuum line and held at -30°C (the freezer temperature) for 24 hours, the yellow colour of N-bromosuccinimide was observed to fade leaving a partially white residue. The product was distilled into a calibrated cold finger (figure 2.5) on the vacuum line resulting in the collection of 6.5 cm^3 of a bright brownish-yellow liquid, which was then distilled over as short a distance as possible into a rotaflo ampoule and kept at -196°C . The gas phase infrared spectrum of a sample of this product is shown in figure 2.

2.9.3 Methyldichloramine:

Methyldichloramine was prepared by a modification of the method of G.H. Coleman (47) in which methylammonium chloride was reacted with sodium chlorate (I):



The modifications were:

1. A very strong solution of sodium chlorate (I) was prepared just before the chlorination of the ammonium salt.
2. The ammonium salt was added in the solid phase and in small portions to the solution.

A solution of sodium chlorate (I) (2.2 mol) was prepared as described in 2.9.1. Then inside a three litre conical flask the solution was cooled internally by ice (650g) and externally by an ice-salt mixture. Solid methylammonium chloride (1 mol) was added to the sodium chlorate (I) solution in small portions with continuous stirring. After most of the solid had been added the colour of the solution changed to milkish white and the smell of methyldichloramine was noticeable. After the complete addition the contents of the flask were poured into a separating funnel when two layers were observed. The methyldichloramine layer was covered by an aqueous layer. The lower layer was separated and dried over calcium chloride. The gas phase infrared spectrum of the product is shown in figure 3. The product was kept in a Rotaflo storage ampoule at -196°C .

2.9.4 Methylchloramine:

Preparation of methylchloramine was attempted by reaction of methylammonium chloride with sodium chlorate (I) as described by G.H. Coleman (47).

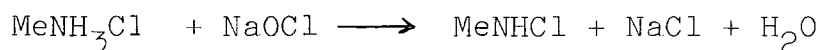

The gas phase infrared spectrum of the product showed the presence of methyldichloramine and methylamine. This disproportionation was found to occur too rapidly for the chloramine to be useful in the type of reactions studied in this work. This type of disproportionation has been studied by

J. Jander and C. Lafrenz (36)

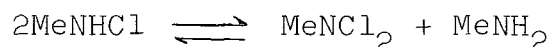

2.9.5 Dimethyliodamine:

The preparation of dimethyliodamine was attempted by reacting dimethylamine and iodine in aqueous solution in a similar manner to that used by J. Jander (48). Dimethylamine 4.02g (89.5 mmol) was mixed rapidly with a solution of 10.03g (39.5 mmol) iodine dissolved in an aqueous solution of potassium iodide at 0°C inside a conical flask. A yellowish brown precipitate was formed, this was filtered on a glass sinter. The solid was washed three times with distilled water containing some dimethylamine at 0°C. The process of filtration was very slow and the colour of the solid changed to brown. The product was washed three times with methanol twice with diethyl ether and finally with pentane at -35°C, the process of washing was also slow and that might be due to some frozen water blocking the pores of the glass sinter. The solid was dried under vacuum at -35°C and the colour of this solid changed to dark brown. Elemental analysis showed that the solid product was not dimethyliodamine and it implied the decomposition of the iodamine to compounds containing less iodine.

2.10 The preparation of phosphines

The preparations of dimethylaminodichlorophosphine and bis(dimethylamino)chlorophosphine were carried out by reacting phosphorus trichloride with dimethylamine(49,50) in different stoichiometric ratios as shown by the following equations:

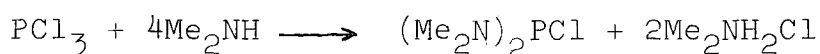

The procedures of the preparations were identical, so only the preparation of dimethylaminodichlorophosphine is discussed in detail:

Phosphorus trichloride 15.92g (162mmol) was degassed, and dissolved in 50 cm³ of dry degassed petroleum ether inside a three-necked round bottom flask which was kept under a dry atmosphere of nitrogen by a tap connected to the nitrogen line and fitted in one of the side necks. The central neck was equipped with a magnetic stirrer which kept the solution under continuous stirring. The third neck was equipped with a dropping funnel containing 16.5g (364 mmol) of dry degassed dimethylamine in 60 cm³ of dry degassed petroleum ether. The flask was cooled to -6°C and the amine solution was added drop wise with continuous stirring. The formation of white solid was observed and when the addition of the amino solution was completed the reaction mixture was allowed to warm to room temperature whilst stirring for half an hour. The white solid (dimethylammoniumchloride) was separated by filtration (inside a dry box) and washed three times with petroleum ether. The filtrate was collected in a conical flask equipped with a tap and the solvent was pumped away through the vacuum line leaving a colourless liquid. The ³¹Pnmr spectrum of this liquid showed one sharp peak at -165.1 p.p.m. due to the formation of Me₂NPCl₂ (51). The ³¹Pnmr spectrum of the product of the preparation of (Me₂N)₂PCl showed one sharp peak only at -158.9 p.p.m., close to the reported value of that compound (δ-158.7 p.p.m.) (51,52).

The results of elemental analysis are shown in the following tables:

Element	Calculated for Me_2NPCl_2	Found	Element	Calculated for $(\text{Me}_2\text{N})_2\text{PCl}$	Found
C	16.45	16.32	C	31.08	31.25
H	4.11	4.29	H	7.77	7.81
N	9.60	9.86	N	18.13	18.39
P	21.25	21.20	P	20.07	20.01
Cl	48.59	48.41	Cl	22.95	22.74

The following table shows the other phosphines used in this work, the preparations of which are described in other chapters. The section number for their preparation is given in column three.

No.	Phosphine	Section No.	^{31}P nmr/ppm found	^{31}P nmr/ppm reported	References
1	$(\text{Me}_2\text{N})_3\text{P}$	7.15	-122.5	-122.5	53
2	Me_2NBr_2	4.7	-175.2	-	
3	$(\text{Me}_2\text{N})_2\text{PBr}$	4.7	-170.9	-	
4	Me_2NPF_2	6.12	-143.5	-143.0	54
5	$(\text{Me}_2\text{N})_2\text{PF}$	6.14	-151.9	-151.4	55
6	PI_3	5.12	-177.5	-178.0	56
7	$\text{P}(\text{OMe})\text{Cl}_2$	3.11	-181.6	-181.0	57
8	$\text{P}(\text{OMe})_3$	3.4	-124	-124.3	58
9	$\text{PhP}(\text{C}_6\text{H}_{11})_2$	8.4.2	-1.5	-2.5	59
10	$\text{Ph}_2\text{P}(\text{C}_6\text{H}_{11})$	8.4.3	3.2	4.4	59
11	Me_2NPh_2	4.2	-64.3	-63.9	60
12	$(\text{Me}_2\text{N})_2\text{PPh}$	4.2	-99.8	-100.3	60

2.11 Other phosphorus compounds used

The following compounds were obtained from FLUOROChem Ltd. and their purity was checked by ^{31}P nmr spectroscopy. Methyl dichlorophosphine, dimethylchlorophosphine, bis(methoxy)chlorophosphine, phenyl bis(methoxy)phosphine, diphenylmethoxy

phosphine, trimethylphosphine and dicyclohexylchlorophosphine. Tributylphosphine, triphenylphosphine, triphenylphosphite, hexamethyl phosphoramidate, phosphorus trichloride and phosphorus tribromide were obtained from BDH Chemicals Ltd., and phenyldichlorophosphine and diphenylchlorophosphine from Alfa Division Lancaster Syntheses Ltd.

2.12 Other chemicals

2.12.1 Dimethylamine:

Dimethylamine was obtained in 250 cm³ ampoule obtained from BDH Chemicals Ltd., which was cooled in a freezer at -30°C. The top of the ampoule was then cracked off and the liquid poured into a Rotaflo storage ampoule (figure 2.2c) containing sodium wire. The air was pumped off on the vacuum line while the amine was frozen at -196°C.

2.12.2 Hydrogen chloride:

The gas was obtained in cylinders from BOC Special Gases and introduced into a 10 litre bulb connected to the fractionation section of the vacuum line and purified by fractionation as described in 9.2.

2.12.3 Chlorine:

Chlorine was obtained in cylinders from BOC Special Gases.

2.12.4 Borontrichloride and borontribromide were obtained from Fisons, purified and kept in Rotaflo ampoule.

2.12.5 Other standard items of stock chemicals:

These chemicals were obtained from the usual sources. The petroleum ether used was the 30-40°C fraction and it was dried over sodium wire and transferred through the vacuum line into a storage Rotaflo ampoule.

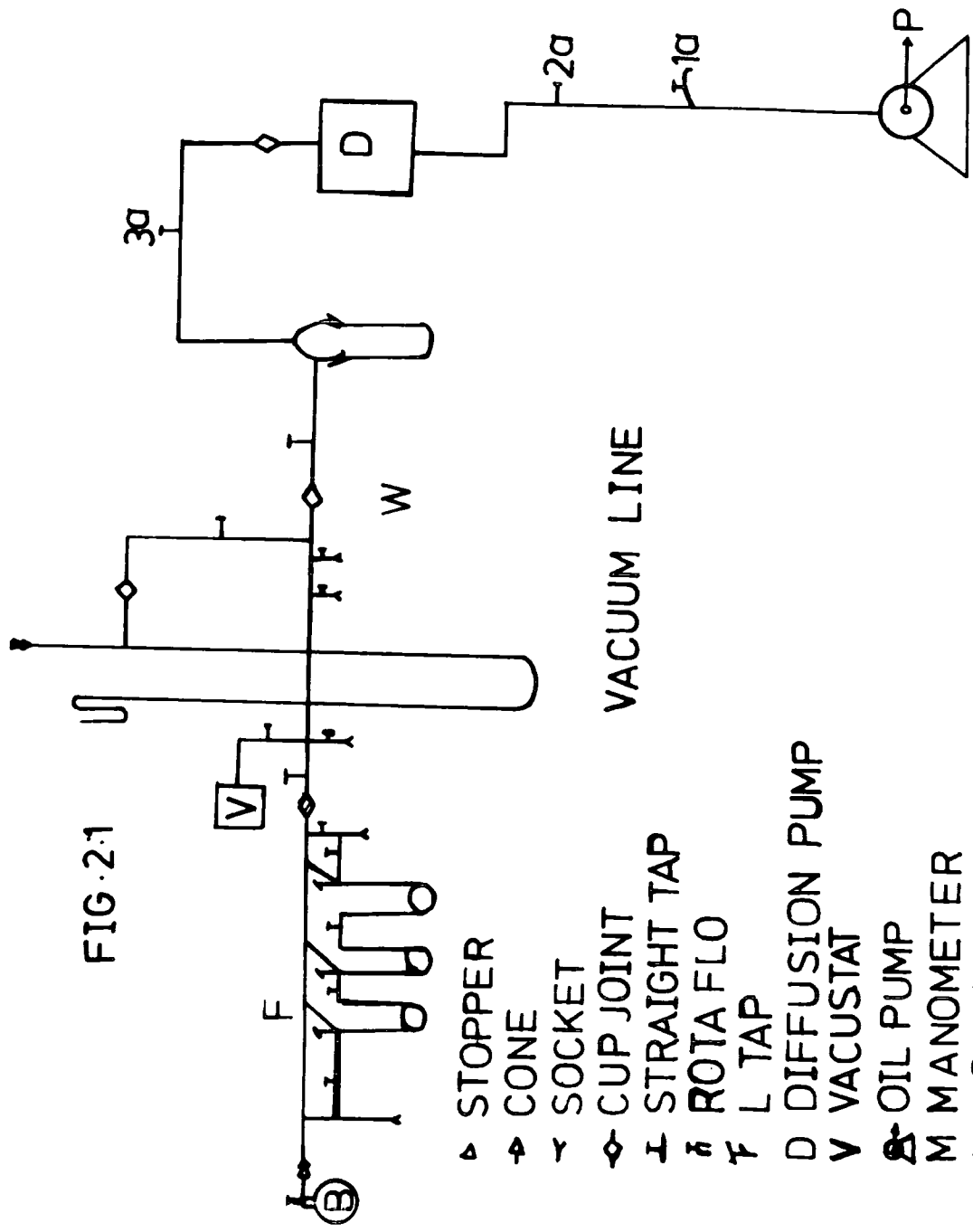

FIG. 2.1

- ▲ STOPPER
- CONE
- ⊥ SOCKET
- ◆ CUP JOINT
- ┆ STRAIGHT TAP
- ⊥ ROTAFLO
- ┆ L TAP
- D DIFFUSION PUMP
- V VACUSTAT
- ⊙ OIL PUMP
- M MANOMETER
- B MOLECULER WEIGHT BULB

VACUUM LINE

FIG. 2.2

- ⊕ CONE
- ∩ SOCKET
- ▼ STOPPER
- ⊕ CUP JOINT
- ⊕ SCREW
- RULE
- ⊕ TAP

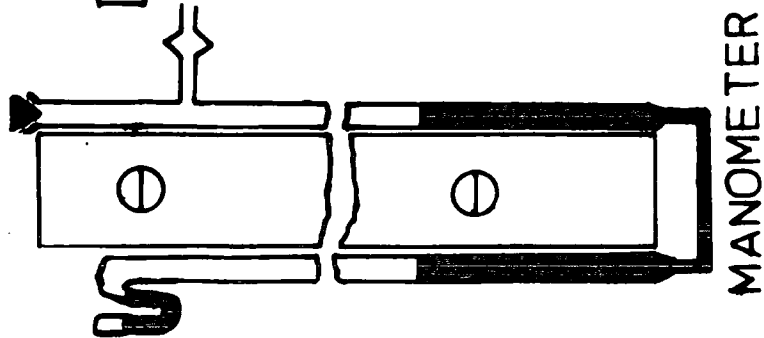

MANOMETER

FIG. 2.2a

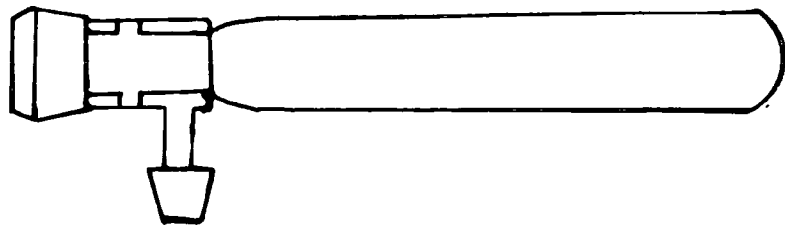

STORAGE TUBE
FIG. 2.2c

REACTION VESSEL
FIG. 2.2b

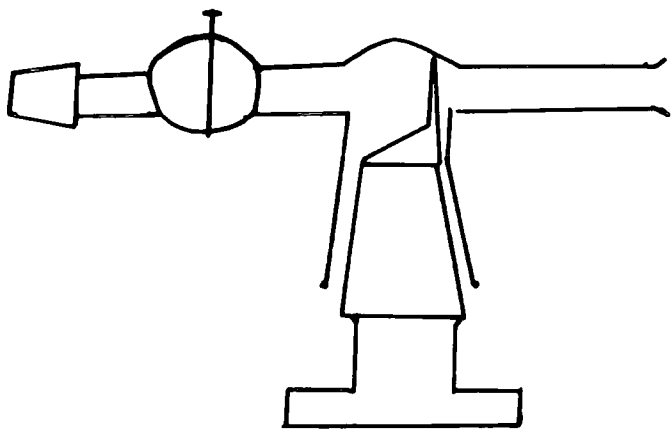
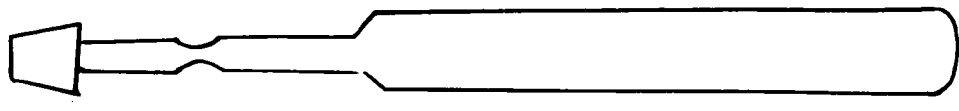

AMPOULE BREAKER

FIG. 2.3

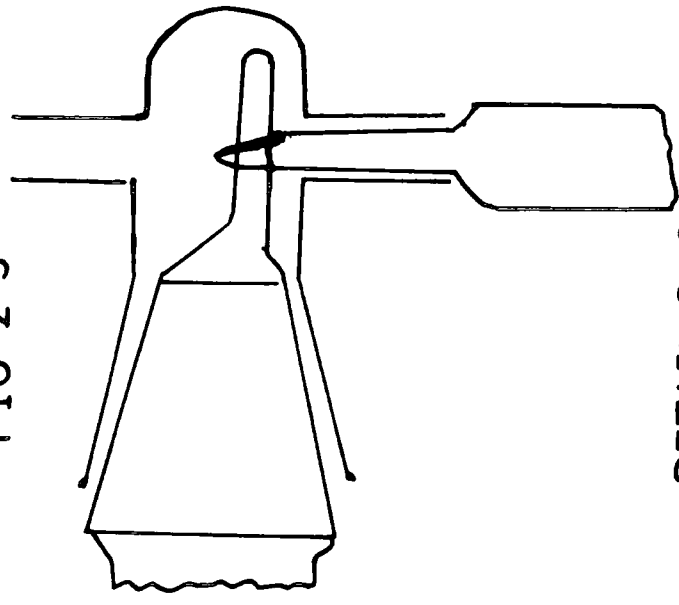

DETAIL SHOWING FITTING OF 16MM AMPOULE PRIOR TO OPENING

16MM
HEAVY WALL PYRE X REACTION
AMPOULE

A THE MAIN PORT
 C COLD TRAP
 W WATER

B BUBBLER
 N NEEDLE VALVE
 O QUICK ENTRY PORT
 → DIRECTION OF FLOW
 T TAP
 D DRYING TOWER
 → ROTA FLOW

FIG. 2-6

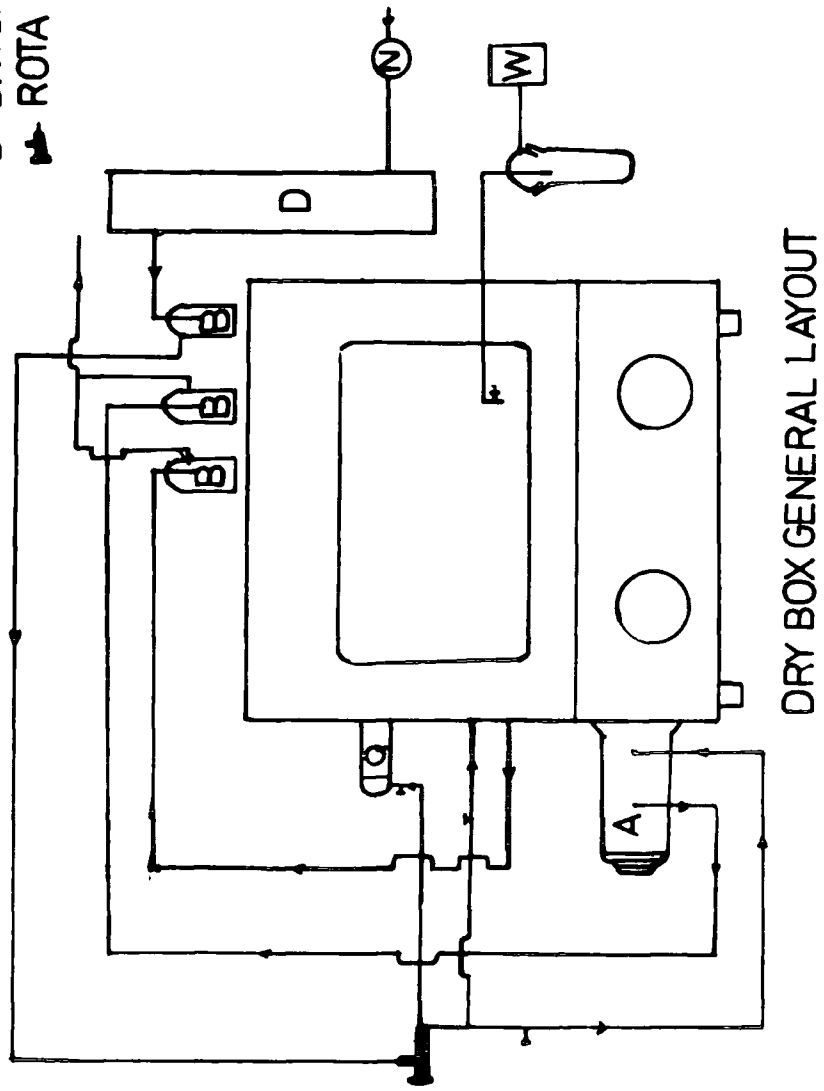

DRY BOX GENERAL LAYOUT

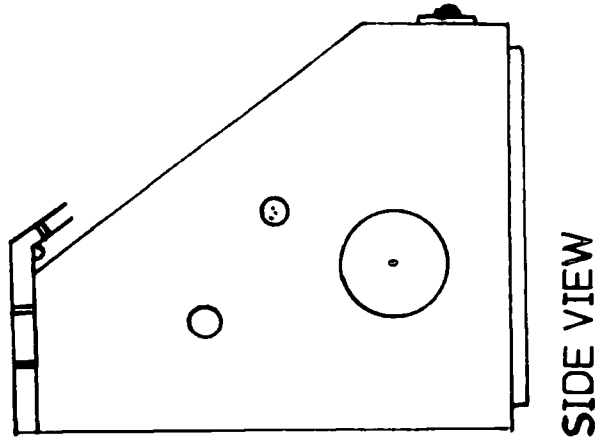

SIDE VIEW

FIG. 2.5

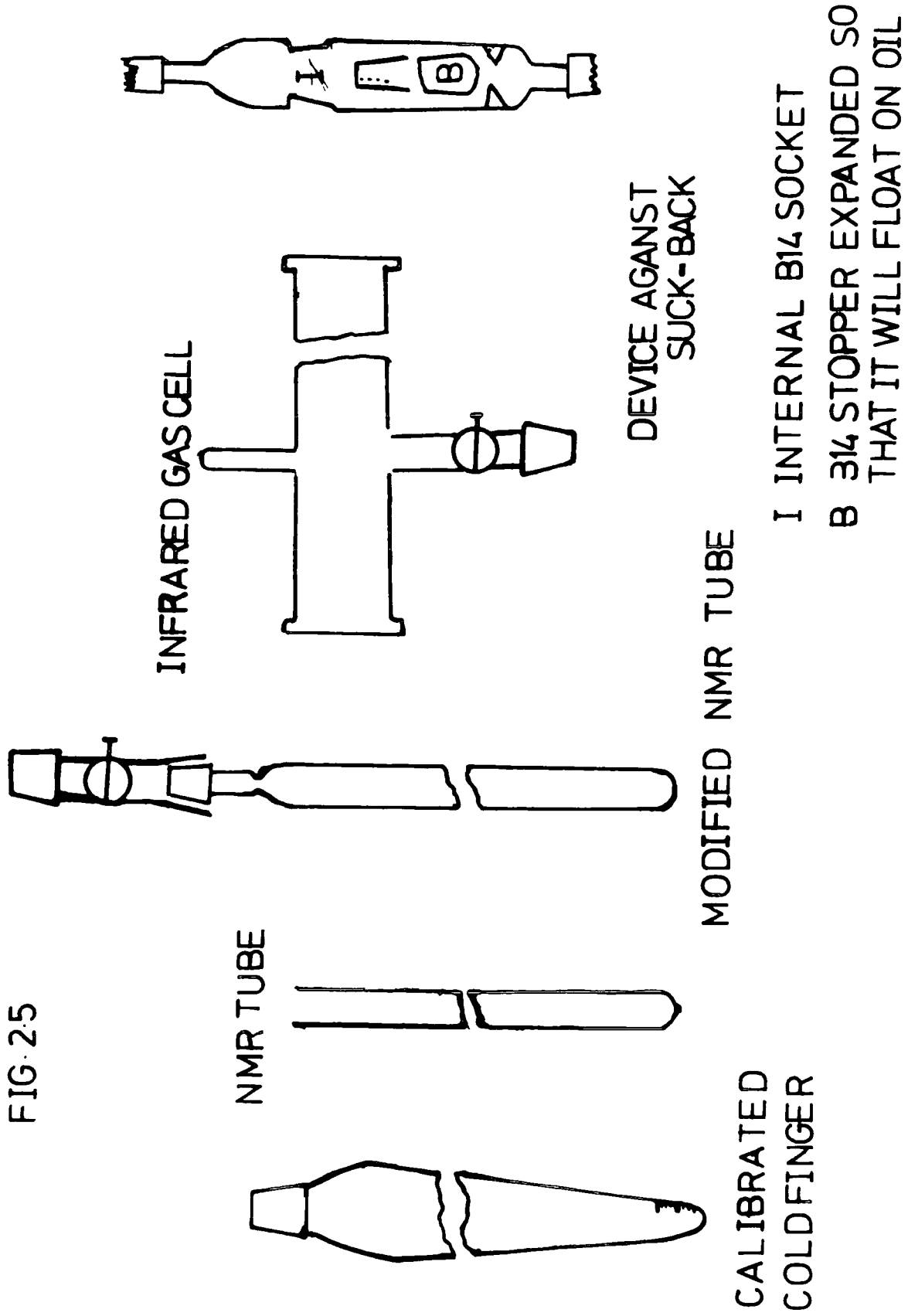



CHAPTER THREE

THE REACTIONS OF HALAMINES WITH
A VARIETY OF PHOSPHITES

3.1 Introduction

Very few studies of the reactions between phosphorus acid esters and N-halamines have been reported. Petrova and Sokol'skii reacted Et_2NCl with some phosphorus acid esters (phosphites) (2).

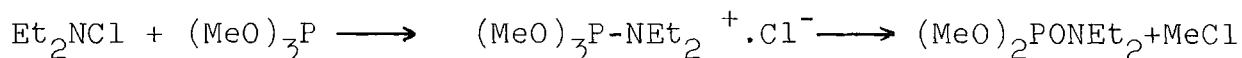

They assumed that an addition compound was formed first, then the chloride ion attacked one of the carbon atoms of the methoxy groups, in an $\text{S}_{\text{N}}2$ reaction to produce MeCl and $(\text{MeO})_2\text{P}^{\text{O}}\text{NEt}_2$. In this reaction the addition product and the alkyl halide were not isolated. The intermediate product was isolated in reactions of R_2NCl with $(\text{PhO})_3\text{P}$ in ether solution with cooling (2, 1) and the ionic nature of the product was confirmed by its $^{31}\text{Pnmr}$ (1).

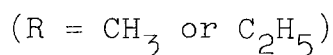
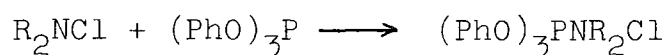

In a parallel reaction to those described above Petrov and Sokol'skii reacted trimethylphosphite with ethylhypochlorite (2). The products of this reaction were ethyldimethyl phosphite and methyl chloride. They suggested that the products of this reaction were formed by way of the phosphonium salt:

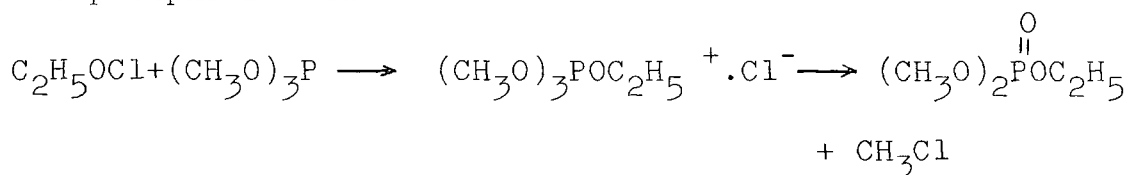

The same team of workers reacted triphenyl phosphite with ethyl hypochlorite (2) and they found that the phosphite was oxidised to phosphate, with the production of ethyl chloride. These workers suggested that the final products were formed from an addition product, where the chloride ion attacked the carbon atom of the ethoxy group by an S_N2 reaction:

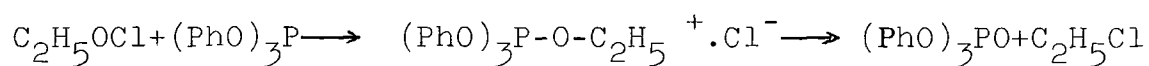

Trialkyl phosphites have been reacted with sulphenyl halides (61,62).

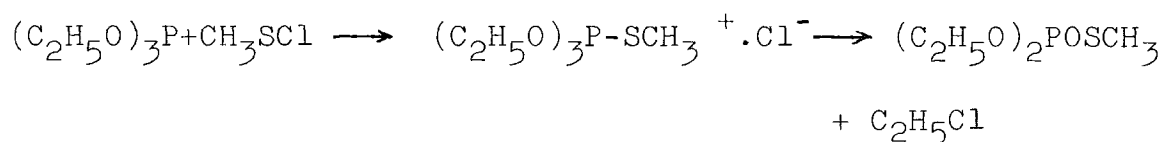

Petrov, Sokol'skii and their co-worker (61) reacted triphenyl phosphite with ethane sulphenyl chloride, the reaction produced good yield of 0,0,0-tri-phenyl phosphorothioate. This is a rare example of cleavage of a carbon-sulphur bond in reactions of this type:

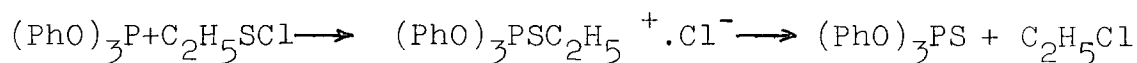

The intermediate compounds of these reactions were not isolated. From the above reactions it is clear that the susceptibility of carbon atoms bonded through an electro-negative atom to phosphorus decreases in the order OCH₃, OC₂H₅, SCH₃, SC₂H₅, OC₆H₅.

The present work has been directed to expand the research in this field and to rationalise the mechanism of this type of reaction.

3.2 The reaction between triphenyl phosphite and dimethyl bromamine

A sample of triphenyl phosphite (3.7 mmol) was dissolved in 4cm³ of dry, degassed petroleum ether inside a reaction vessel (figure 2.2b). A dry, degassed dimethyl bromamine (4.3 mmol) was condensed onto the phosphite solution at -196°C. The vessel was kept at -46°C for five hours with occasional shaking, then it was allowed to warm to room temperature. The gas phase infrared spectrum of the most volatile fraction showed a mixture of petroleum ether and dimethyl bromamine. These were pumped away through the vacuum line leaving a creamish-white solid as a product. This was washed three times with petroleum ether inside the dry box and it was dried under vacuum. The ³¹Pnmr spectrum of this solid showed one broad peak at 18.1 p.p.m., this chemical shift is very close to that of (PhO)₃PNMe₂⁺.Cl⁻ (1) prepared by reacting Me₂NCl with (PhO)₃P. The infrared spectrum of the product is shown in figure 4 and the elemental analyses data are listed in Table 3.1.

Table 3.1

Element	Calculated for (PhO) ₃ PNMe ₂ Br	Found
C	55.31	54.79
H	4.84	5.02
N	3.23	3.51
P	7.14	7.10
Br	18.41	18.27

The previous results indicate that simple amination occurred in the phosphorus atom:

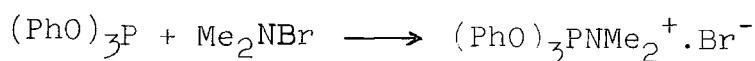

3.3 The reaction between trimethyl phosphite and dimethyl bromamine

A sample of trimethyl phosphite (4.1 mmol) was dissolved in 3cm³ of dry, degassed petroleum ether inside a modified nmr tube (figure 2.5). Dry, degassed dimethyl bromamine (5.3 mmol) was condensed onto the phosphite solution at -196°C. The tube was kept at -46°C for five hours with occasional shaking and then it was allowed to warm to room temperature. The gas phase infrared spectrum of the most volatile fraction showed a mixture of methyl bromide, petroleum ether and dimethyl bromamine. These were pumped away through the vacuum line, leaving a colourless liquid. The ³¹Pnmr spectrum of this liquid showed one sharp peak at -8.5 p.p.m., this chemical shift is very close to the chemical shift of (MeO)₂PONMe₂ which was prepared by reacting dimethyl chloramine and trimethyl phosphite (1). The infrared spectrum of the liquid is very similar to that of (MeO)₂PONMe₂, the elemental analysis results are listed in Table 3.2.

Table 3.2

Element	Calculated for (MeO) ₂ PONMe ₂	Found
C	31.37	30.79
H	7.84	8.03
N	9.15	9.31
P	20.26	20.17

These results indicated that the overall reaction was:

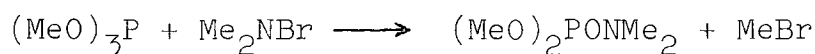

The products of this reaction might have been produced through an unstable phosphonium salt ((MeO)₃PNMe₂.Cl).

3.4 The preparation of tris(thiomethoxy) phosphine

This was prepared by reacting yellow phosphorus 3.1g (0.1 mmol) with dimethyl sulphide 14.1g (0.15 mmol) (63). The purity of the product was checked by ^{31}P nmr spectroscopy which showed one sharp peak only at -124 p.p.m. due to the formation of tris(thiomethoxy)phosphine (58).

The elemental analyses are listed in Table 3.3.

Table 3.3

Element	Calculated for	Found
C	20.93	19.69
H	5.23	5.77
S	55.83	55.40
P	18.02	18.16

3.5 The reaction between dimethylchloramine and tris(thiomethoxy) phosphine

Tris(thiomethoxy)phosphine (6.98 mmol) was dissolved in 3cm^3 of dry, degassed dichloromethane inside a reaction vessel (figure 2.2b) and 8.8 mmol of dimethylchloramine was condensed into it. The vessel was held at -45°C for eight hours. The gas phase infrared spectrum of the most volatile fraction showed a mixture of dichloromethane and dimethyl chloramine which were pumped away leaving a white solid. A sample of this solid was placed inside a modified Pnmr tube

(figure 2.5) and it was noticed that the solid substance started to look wet. The ^{31}P nmr spectrum of the sample showed one sharp peak only due to a liquid phosphorus compound at -98.4 p.p.m. and it was noticed that the solid had liquefied at the spectrometer probe temperature 35°C . The tube was connected to the vacuum line and the gas phase infrared spectrum showed the presence of methylchloride only and a colourless liquid remained inside the tube. The infrared spectrum of the liquid is shown in figure 5 and the elemental analysis data are listed in table 3.4.

Table 3.4

Element	Calculated for $(\text{MeS})_2\text{PSNMe}_2$	Found
C	23.88	23.69
H	5.97	6.35
N	6.97	7.30
P	15.42	15.62
S	47.76	47.41

These results indicate that the overall reaction was as follows:

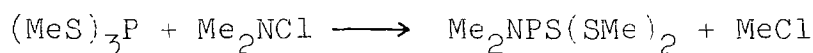

With, perhaps, intermediate formation of the ionic species $(\text{MeS})_3\text{PNMe}_2 + \text{Cl}^-$.

3.6 The reaction between dimethylbromamine and tris(thiomethoxy)phosphine

A sample of dry degassed dimethylbromamine (4.9 mmol) was condensed into 2.9 mmol of tris(thiomethoxy)phosphine dissolved in 4cm^3 of dry degassed petroleum ether inside a

reaction vessel (figure 2.2b). The vessel was kept at -46.5°C for eight hours when the tube was allowed to warm to room temperature. the infrared spectrum of the most volatile fraction showed a mixture of petroleum ether and dimethylbromamine. The volatile substances were pumped away leaving a yellowish-white solid inside the tube. A sample of the solid product was transferred into a modified Pnmr tube (figure 2.5) in the drybox. The ^{31}P nmr spectrum showed one sharp peak at -98.4 p.p.m. and it was noticed that the solid had melted to a colourless liquid.

The tube was attached to the vacuum line and the gas phase infrared spectrum showed the presence of bromomethane only, this was pumped away leaving the colourless liquid inside the tube. The infrared spectrum of this liquid was identical to the infrared spectrum of $(\text{MeS})_2\text{PSNMe}_2$ (figure 5) obtained from the corresponding dimethylchloramine reaction (3.5). The elemental analyses are shown in table 3.5.

Table 3.5

Element	Calculated for $(\text{MeS})_2\text{PSNMe}_2$	Found
C	23.88	22.46
H	5.97	7.01
N	6.97	6.88
P	15.42	15.56
S	47.76	47.91

Then the overall reaction was as follows:



With the likely formation of $(\text{MeS})_3\text{PNMe}_2^+ \cdot \text{Br}^-$ as an intermediate.

3.7 The reaction between dimethylchloramine and bis(methoxy)phenyl phosphine

A sample of bis(methoxy)phenyl phosphine (4.7 mmol) was dissolved in 2 cm³ of dry degassed petroleum ether inside a modified Pnmr tube (figure 2.5). A dry degassed sample (5.65 mmol) of dimethylchloramine was transferred by the vacuum line and condensed on to this solution at -196°C. The tube was held at -46.5°C for eight hours and then allowed to warm to room temperature. The gas phase infrared spectrum of the most volatile fraction showed a mixture of dimethylchloramine, petroleum ether and methylchloride. These were pumped away leaving a colourless liquid which showed one sharp peak in the ³¹Pnmr spectrum at -24.2 p.p.m. (figure 33). The infrared spectrum of the liquid product is shown in figure 6 and the elemental analyses are shown in table 3.6.

Table 3.6

Element	Calculated for (MeO)POPhNMe ₂	Found
C	54.23	73.70
H	7.04	7.53
N	7.04	7.21
P	15.58	15.47

These results indicate that the overall reaction was as follows:

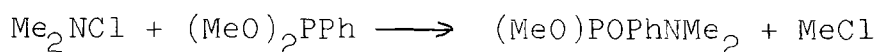

3.8 The reaction between dimethylbromamine and bis(methoxy)phenyl phosphine

This reaction was carried out using the same technique

described above (3.7), except that the tube was kept at -30°C (the freezer temperature) for eight hours. The amount of the reactants were 3.7 mmol of methoxy phenyl phosphine and 4.3 mmol of dimethyl bromamine. The tube was allowed to warm to room temperature and the gas phase infrared spectrum of the most volatile fraction showed a mixture of methylbromide, petroleum ether and dimethylbromamine. These were pumped away leaving a colourless liquid giving one sharp peak at -24.1 p.p.m. in its ^{31}P nmr spectrum. This chemical shift was close to the chemical shift found for $(\text{MeO})\text{POPhNMe}_2$ which was prepared by reacting dimethylchloramine with bis(methoxy)phenyl phosphine (3.7). The infrared spectra for the two liquids were also very similar. These results indicate that the overall reaction was:

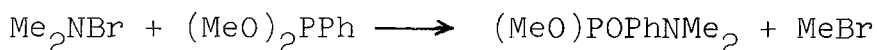

3.9 The reaction between methoxydiphenyl phosphine and dimethyl chloramine

A sample of methoxydiphenyl phosphine (5.56 mmol) was dissolved in 4cm^3 of dry degassed petroleum ether inside a reaction vessel (figure 2.2b). On to this solution 8.8 mmol of dimethyl chloramine was condensed at -196°C . After the reactant had been kept at -46.5°C for seven hours, a brownish orange solid formed. The cell was allowed to warm to room temperature and the gas phase infrared spectrum of the most volatile fraction showed a mixture of methyl chloride, dimethyl chloramine and petroleum ether. These were pumped away through the vacuum line leaving a brownish orange solid. The ^{31}P nmr spectrum of this solid dissolved in dichloromethane showed one sharp peak at -29.1 p.p.m.,

this chemical shift corresponds to the known chemical shift of $\text{Ph}_2\text{PONMe}_2$ (δ -29.6 p.p.m. (64)). The infrared spectrum of this product showed the formation of a phosphorus oxygen double bond, by its characteristic band at 1260 cm^{-1} (Fig.7). The elemental analyses results are listed in table 3.7.

Table 3.7

Element	Calculated for $\text{Ph}_2\text{PONMe}_2$	Found
C	68.57	67.93
H	6.53	7.20
N	5.71	6.15
P	12.65	13.01

These results indicate that the reaction was as follows:

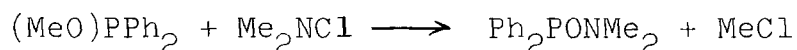

3.10 The reaction between methoxydiphenyl phosphine and dimethyl bromamine

A sample of methoxy diphenyl phosphine (3.7 mmol) dissolved in 4 cm^3 of dry degassed petroleum ether, was reacted with 5.6 mmol of dry degassed dimethyl bromamine in a reaction vessel at -22.2°C for seven hours. The infrared spectrum of the most volatile fraction showed a mixture of methyl bromide, dimethyl bromamine and petroleum ether. These were pumped away leaving a brownish orange solid. The ^{31}P nmr spectrum of the solid product dissolved in dichloromethane showed one sharp peak only at -29.1 p.p.m., this chemical shift is identical to the chemical shift of $\text{Ph}_2\text{PONMe}_2$ which was prepared by reacting $(\text{MeO})\text{PPh}_2$ with dimethylchloramine(3.9). The infrared spectrum of

this compound corresponds very closely to the infrared spectrum of $\text{Ph}_2\text{PONMe}_2$ (figure 7). The elemental analyses results are listed in table 3.8.

Table 3.8

Element	Calculated for $\text{Ph}_2\text{PONMe}_2$	Found
C	68.57	67.38
H	6.53	6.71
N	5.71	5.53
P	12.65	12.72

These results indicate that this reaction can be represented by the following equation:

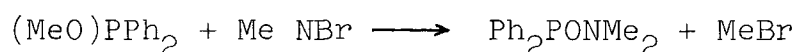

3.11 The preparation of bis(methoxy)chloro phosphine

This was prepared by reacting tri(methoxy)phosphine 15g (121 mmol) with phosphorus trichloride 33.24g (242 mmol) (65). The purity of the product was checked by $^{31}\text{Pnmr}$ spectroscopy, which showed one sharp peak only at -196.0 p.p.m. due to the formation of bis(methoxy)chloro phosphine. The elemental analyses data are shown in table 3.9.

Table 3.9

Element	Calculated for $(\text{MeO})_2\text{PCl}$	Found
C	18.68	18.95
H	4.67	5.01
P	24.13	24.07
Cl	27.60	27.26

3.12 The reaction between bis(methoxy)chloro phosphine and dimethyl chloramine

A dry degassed sample of dimethyl chloramine (7.5 mmol) was transferred by the vacuum line and condensed on to 5.6 mmol of bis(methoxy)chloro phosphine dissolved in 3 cm³ of dry degassed dichloromethane inside a modified Pnmr tube (figure 2.5) at -196°C. The tube was kept at -45°C for eight hours. The gas phase infrared spectrum of the most volatile fraction showed a mixture of dichloromethane, dimethylchloramine and methyl chloride. On pumping the volatile materials away a colourless liquid was left, which had a ³¹Pnmr spectrum (figure 34) showing the presence of one sharp peak only at -19.3 p.p.m. This chemical shift corresponded to the chemical shift of (MeO)PONMe₂Cl which has a tetrahedral structure. The infrared spectrum of this liquid is shown in figure 8. The elemental analyses are listed in Table 3.10 and agreed with the molecular formula (MeO)PClNMe₂.

Table 3.10

Element	Calculated for (MeO)PClNMe ₂	Found
C	22.86	21.94
H	5.72	6.07
N	8.89	9.11
P	19.69	19.54
Cl	22.52	22.21

These results indicate that the above reaction could be represented by the following:

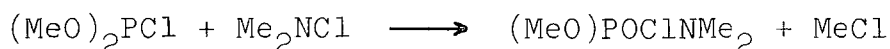

3.13 The reaction between bis(methoxy)chloro phosphine and dimethylbromamine

This reaction was carried out by applying the same technique employed in 3.12. The amount of the reactants were 5.8 mmol of dimethyl bromamine and 5.1 mmol of

bis(methoxy)chloro phosphine. After the reaction the gas phase infrared spectrum of the most volatile fraction showed a mixture of dimethylbromamine, dichloromethane (used as a solvent) and methyl bromide. These were pumped away leaving a colourless liquid, the ^{31}P nmr spectrum of which showed one sharp peak only at -19.1 p.p.m. This chemical shift is very close to that of $(\text{MeO})\text{POClNMe}_2$ prepared as described in section 3.12. The infrared spectrum of this liquid is identical to that of $(\text{MeO})\text{POClNMe}_2$ (figure 8). The elemental analyses results are shown in table 3.11.

Element	Calculated for $(\text{MeO})\text{POClNMe}_2$	Found
C	22.86	22.07
H	5.72	5.53
N	8.89	8.49
P	19.69	20.11
Cl	22.52	21.94

These results indicate that the above reaction was

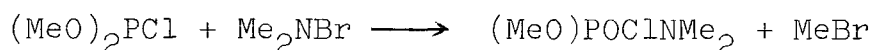

3.14 The reaction between methoxydichloro phosphine and dimethyl chloramine

Methoxydichloro phosphine (6.7 mmol) was degassed and dissolved in 4 cm³ of dry degassed petroleum ether, inside a modified Pnmr tube (figure 2.5). Dimethylchloramine (8.5 mmol) was degassed and condensed onto the phosphine solution at -196°C. The tube was kept at -30°C (the freezer temperature) for eighteen hours and then allowed to warm to room temperature. The gas phase infrared spectrum of the

most volatile fraction showed a mixture of methylchloride, petroleum ether, and dimethylchloramine. These were pumped away through the vacuum line leaving a colourless liquid. The ^{31}P nmr spectrum of this liquid showed one sharp peak only at -19.7 p.p.m. (figure 35). The infrared spectrum is shown in figure 9, and the elemental analyses are listed in table 3.12.

Table 3.12

Element	Calculated for $\text{Me}_2\text{NPOCl}_2$	Found
C	14.82	14.65
H	3.71	4.01
N	8.65	8.80
P	19.15	19.39
Cl	43.79	42.44

These results indicate that this reaction was:

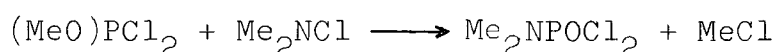

3.15 The reaction between methoxydichloro phosphine and dimethyl bromamine

A degassed sample of methoxy dichloro phosphine (5.3 mmol) was condensed onto 4 cm³ of dry degassed petroleum ether, inside a modified Pnmr tube (figure 2.5). A dry degassed sample of dimethyl bromamine (7.1 mmol) was condensed onto the phosphine solution at -196°C. The tube was kept at -30°C for nine hours and then allowed to warm to room temperature. The gas phase infrared spectrum of the most volatile fraction showed a mixture of methyl bromide,

petroleum ether and dimethyl bromamine. These were pumped away leaving a colourless liquid the ^{31}P nmr spectrum of which showed one sharp peak only at -19.3 p.p.m. The chemical shift corresponded (within experimental error) to that of $\text{Me}_2\text{NPOCl}_2$ (prepared by reacting dimethyl chloramine with methoxy dichloro phosphine as described in Section 3.14). The infrared spectrum of this compound was very similar to that of $\text{Me}_2\text{NPOCl}_2$ (figure 9). Elemental analyses are shown in Table 3.13.

Table 3.13

Element	Calculated for $\text{Me}_2\text{NPOCl}_2$	Found
C	14.82	14.61
H	3.71	3.95
N	8.65	8.89
P	19.15	19.11
Cl	43.79	42.96

These results suggest that the reaction which occurred was:

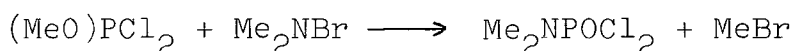

3.16 Results and Discussion

It was found that $(\text{MeO})_{3-n}\text{PY}_n$ ($n = 0,1,2$ and $Y = \text{Cl}$ or Ph) reacted with Me_2NX ($X = \text{Cl}$ or Br) to produce MeX and $(\text{MeO})_{2-n}\text{POY}_n\text{NMe}_2$. When Me_2NX was reacted with tris-thio-methoxy phosphine, the products were $(\text{MeS})_2\text{PSNMe}_2$ and MeX . When tris-phenoxy phosphine was reacted with Me_2NBr the product was $(\text{PhO})_3\text{P.NMe}_2^+.\text{Br}^-$. This product might have been

formed by an S_N2 attack by the phosphorus atom on the nitrogen of the halamine. It seems likely that the reaction of Me_2NX and the aliphatic phosphorus acid esters passes through two steps; the first is an S_N2 attack by the phosphorus atom on the nitrogen atom of the halamine. This would produce an intermediate phosphonium salt and in a second step the halide ion would attack a methyl group in an S_N2 reaction (producing MeX and $P = O$ compounds):

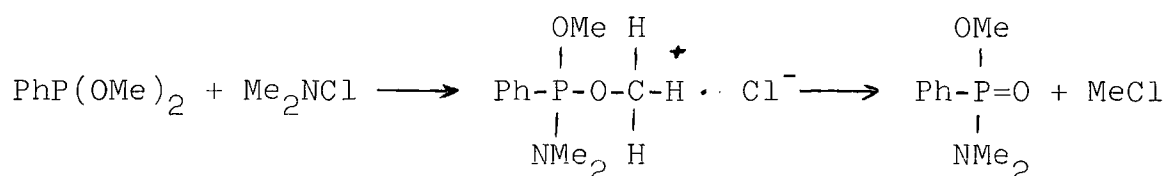

It was very difficult to detect the formation of the intermediate compounds in many cases, but the intermediate species were isolated when Me_2NX was reacted with $(MeS)_3P$. The intermediate compound was probably $(MeS)_3PNMe_2^+ - X^-$ which was isolated as a solid. It decomposed slowly at room temperature ($18^\circ C$) and was transformed completely to $(MeS)_2PNMe_2$ and MeX at $35^\circ C$ in a few seconds. The reaction between Me_2NBr and $(PhO)_3P$ produced $(PhO)_3PNMe_2^+ \cdot X^-$ which is stable at room temperature and its ionic character was indicated by its ^{31}P nmr spectrum which showed a peak in the region expected for tetracoordinate phosphonium ion (1). The stability of this phosphonium ion is attributed to the fact that the chlorine anion cannot easily attack the bond between the benzene ring and oxygen atom. The phenyl derivatives are known to be unreactive towards nucleophilic reactions (67).

From this work it is possible to conclude that $(\text{MeO})_3\text{P}$ and $(\text{MeS})_3\text{P}$ behaved in a similar manner towards Me_2NX . This is due to the fact that both oxygen and sulphur are strongly electronegative atoms, consequently the electronic cloud of the σ -bond will be shifted towards these atoms producing a partial positive charge on the carbon atom. Thus the carbon atom will be susceptible to a nucleophilic attack by the halide ion. The rate of the $\text{S}_{\text{N}}2$ attack by the halide ion is related to the extent of the susceptibility of the carbon atom and since the oxygen atom is more electronegative than the sulphur atom, the partial positive charge produced on the carbon atom linked to oxygen will be greater than that generated on the carbon atom linked to sulphur. Thus the rate of $\text{S}_{\text{N}}2$ reaction will be slower and thus it was possible to observe the intermediate phosphonium salt when $(\text{MeS})_3\text{P}$ was reacted with Me_2NX . To support this concept it is possible to describe the reaction of triethylphosphite and sulphenylchloride (61,62)

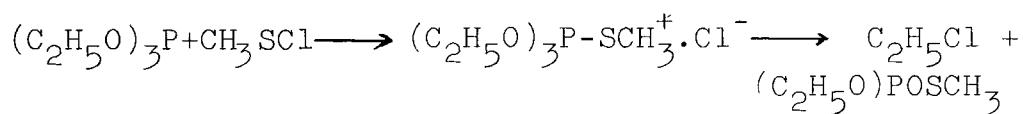

The alkyl halide formed was ethyl chloride instead of methyl chloride, since cleavage of a carbon-oxygen bond by a nucleophile is easier than cleavage of a carbon-sulphur bond (68).

CHAPTER FOUR

THE HALOGENATION OF A VARIETY

OF P-N PHOSPHINES

4.1 Introduction

The simplest halogenating agents are halogen molecules, which react vigorously with many phosphines to produce phosphorus (V) compounds (69) e.g.:



The interhalogens also react and ICl can act as a chlorinating agent for example phenyldichloro phosphine reduces iodine monochloride to iodine (70):

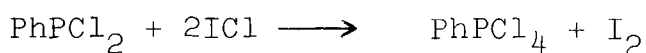

In the studies on phosphorus trifluoride, the final product of oxidation by chlorine, bromine (with the presence of HCl) and iodine monochloride was found to be dichlorotrifluorophosphorane (71):

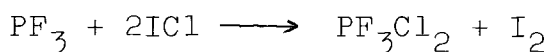
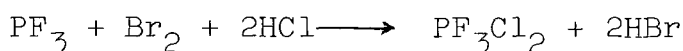
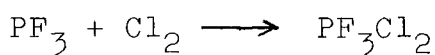

Dichlorotrifluorophosphorane slowly becomes ionic in nature:

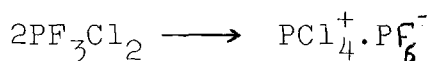

Although halogens oxidise phosphorus (III) compounds to phosphorus (V) compounds it has been reported that careful halogenation can convert primary (72) and secondary phosphines (73) to halophosphines:

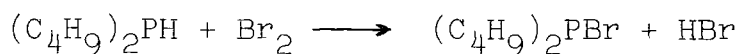
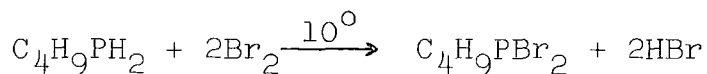

Another study was directed towards the halogenations of some phosphites (74):

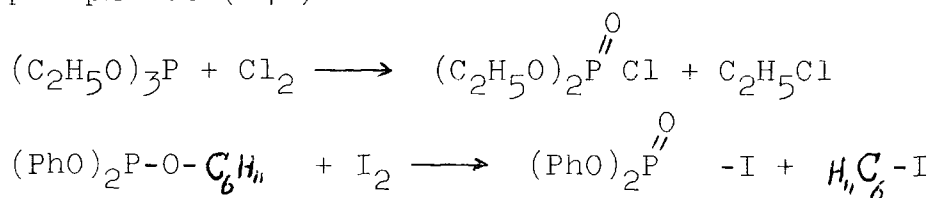

Gorbatenko and Feshchenko reacted tris(dialkylamino)phosphine with iodine (75):

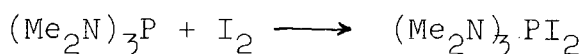

In the presence of excess iodine $(\text{Me}_2\text{N})_3\text{PI}_2$ was produced.

The ^{31}P nmr chemical shift of these products were not reported.

The same workers reacted bis(dialkylamino)iodophosphine with an equimolecular amount of iodine (75); and they found that disproportionation of the initial product occurred:

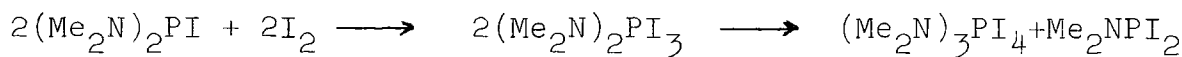

A similar set of reactions occurs when the dimethylamino group is replaced by phenoxy (76):

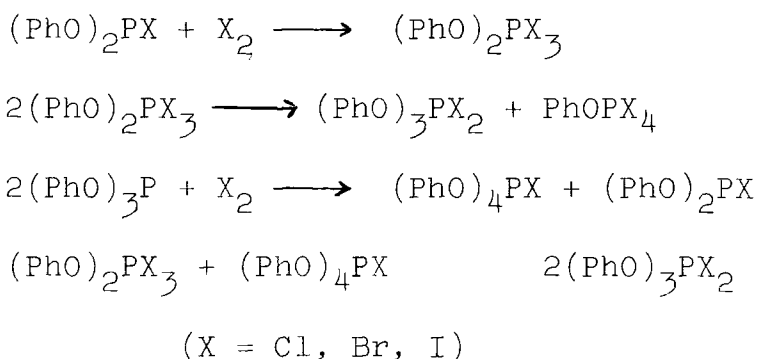

with iodine at temperatures greater than room temperature (77):

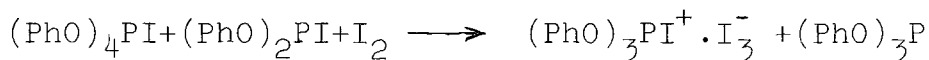

In previous work carried out in this laboratory, dimethylamino dichlorophosphine was chlorinated in a vigorous reaction (1):

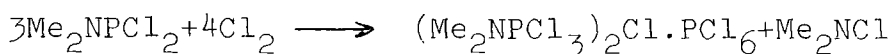

To expand the work in this field a variety of substituted dimethyl-aminophosphines have been halogenated.

4.2 The preparation of dimethylaminodiphenyl phosphine (I) and bis(dimethylamino)phenyl phosphine (II)

The compounds I and II were prepared by reacting dimethylamine with the corresponding phenyl phosphine (78):

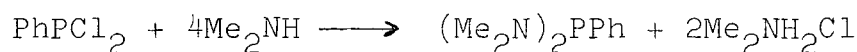
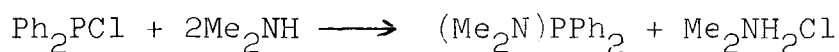

Because similar procedures were used for the preparation of these phosphines, only the preparations of I will be described in detail:

Diphenyl chloro phosphine (142 mmol) was syringed into a three-necked round bottom flask containing dry, degassed petroleum ether (50 cm³). The flask was continuously pressurised with dry nitrogen through a tap fitted to a side neck. The central neck was fitted with a mechanical stirrer. The remaining neck was equipped with a dropping funnel, containing dry degassed petroleum ether (50 cm³) and dimethylamine (295 mmol) under dry nitrogen. The flask was cooled to -6°C in an ice-salt mixture. The amine solution was then added dropwise with continuous stirring. Addition was completed after about an hour, but the stirring was continued for a further 20 minutes to ensure complete reaction. The white precipitate formed (Me₂NH₂Cl) was isolated by filtration under a dry atmosphere of nitrogen and washed three times with ether. The filtrate containing I was collected in a clean conical flask and the solvent was pumped

away leaving a white solid. The purities of I and II were checked by ^{31}P nmr spectroscopy and elemental analysis. The spectrum of the ethereal solution of I showed one sharp peak only at -64.3 p.p.m. due to the formation of Ph_2PNMe_2 (60) and that of II showed one sharp peak at -99.8 p.p.m. due to the formation of $\text{PhP}(\text{NMe}_2)_2$ (60). The elemental analysis data are listed in tables 4.1 and 4.2:

Table 4.1

Element	Calculated for Ph_2PNMe_2	Found
C	73.36	72.15
H	6.99	7.20
N	6.12	6.22
P	13.54	13.46

Table 4.2

Element	Calculated for $\text{PhP}(\text{NMe}_2)_2$	Found
C	61.22	61.11
H	8.67	8.96
N	14.29	15.06
P	15.82	15.63

4.3 The chlorination of diphenyl dimethylamino phosphine

A sample of diphenyl dimethylamino phosphine (34.9 mmol) prepared as described in Section 4.2 was dissolved in 40 cm³ of dry and degassed dichloromethane. This solution was placed inside a three necked round bottom flask under an atmosphere of dry nitrogen. Dry chlorine was bubbled for five minutes through the phosphine solution (cooled to -6°C with an ice-salt mixture). The flask was allowed to warm to room temperature for half an hour under dry nitrogen and then connected to the vacuum line. The gas phase infrared spectrum showed the presence of dichloromethane only. The solvent was pumped away leaving a white solid which was washed

three times with petroleum ether inside the dry box. The ^{31}P nmr spectrum of the product dissolved in dichloromethane showed one sharp peak at -74.9 p.p.m. figure (36) due to the formation of $\text{Me}_2\text{NPPh}_2\text{Cl}^+\cdot\text{Cl}^-$ which has been prepared by reacting Ph_2PCl with Me_2NCl (1). The infrared spectrum of the product is shown in figure (10) and the elemental analysis data are listed in table 4.3:

Table 4.3

Element	Calculated for $\text{Ph}_2\text{PNMe}_2\text{Cl}_2$	Found
C	56.01	56.21
H	5.34	5.57
N	4.67	4.26
P	10.34	16.33
Cl	23.64	22.98

These results indicate that simple chlorination of the phosphine has occurred:

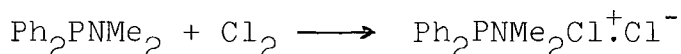

4.4 The bromination of diphenyl dimethylamino phosphine

Diphenyl dimethylamino phosphine prepared as described in Section 4.2 was dissolved in 50 cm^3 of dry and degassed dichloromethane inside a 250 cm^3 three necked round bottom flask which was kept under a dry atmosphere of nitrogen. A sample of bromine (42.8 mmol) was dissolved in 50 cm^3 of dichloromethane and added to the phosphine solution dropwise with continuous stirring at 0°C . When the addition of the

bromine solution was completed the flask was stirred at room temperature under dry nitrogen for half an hour. The flask was then connected to the vacuum line. The gas phase infrared spectrum showed the presence of dichloromethane only which was evaporated off leaving a yellow solid. This was washed three times with petroleum ether inside the dry box. The ^{31}P nmr spectrum of the product dissolved in dichloromethane showed one sharp peak only at -70.9 p.p.m. due to the formation of a phosphonium ion (figure 37). This chemical shift has not been reported previously, the elemental analysis results are listed in table 4.4:

Table 4.4

Element	Calculated for $\text{Ph}_2\text{PNMe}_2\text{Br}_2$	Found
C	43.21	43.01
H	4.12	4.38
N	3.60	3.71
P	7.97	8.06
Br	41.10	41.21

This result indicates that simple bromination of the phosphine had occurred:

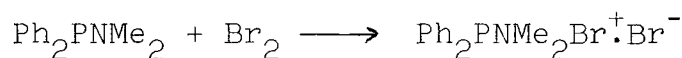

4.5 The chlorination of phenyl bis(dimethylamino)phosphine

Phenyl bis(dimethylamino)phosphine (38.3 mmol) prepared as described in section 4.2 was dissolved in 50 cm³ of dry degassed dichloromethane inside a three necked round bottom

flask which was kept under dry nitrogen. The flask was cooled to -6°C and dry chlorine gas bubbled for three minutes through the phosphine solution which was being stirred continuously. The flask was allowed to warm to room temperature under dry nitrogen for half an hour and then connected to the vacuum line. The gas phase infrared spectrum showed the presence of dichloromethane only. The solvent was pumped away leaving a white solid, which was washed four times with petroleum ether inside the dry box. The ^{31}P nmr spectrum of the product dissolved in dichloromethane showed one sharp peak at -67.8 p.p.m. due to the formation of a tetracoordinate phosphonium ion (figure 38), this chemical shift has not been previously reported. The infrared spectrum of the product is shown in figure (11) and the elemental analysis results listed in table 4.5:

Table 4.5

Element	Calculated for $\text{PhP}(\text{NMe}_2)_2\text{Cl}_2$	Found
C	44.96	45.01
H	6.37	6.46
N	16.49	10.55
P	11.62	11.41
Cl	26.56	26.37

These results indicate that simple chlorination of the phosphine had occurred:

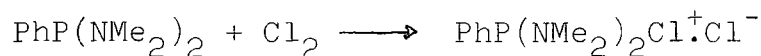

4.6 The bromination of phenyl bis(dimethylamino)phosphine

Phenyl bis(dimethylamino)phosphine (3.57 mmol) prepared as described in section 4.2 was dissolved in 50 cm³ of dry and degassed dichloromethane inside a three necked round bottom flask. A sample of bromine (3.6 mmol) was dissolved in 60 cm³ of dry degassed dichloromethane. The bromine solution was added to the phosphine solution dropwise, under an atmosphere of dry nitrogen at -6°C with continuous stirring. When the addition was completed the contents of the flask were allowed to warm to room temperature with continuous stirring. The flask was connected to the vacuum line and the gas phase infrared spectrum showed the presence of dichloromethane only. This was pumped away leaving an orange solid which was washed five times with petroleum ether, inside the dry box. The ³¹Pnmr spectrum of the product showed one broad peak at -70.9 p.p.m. due to the formation of a tetracoordinate phosphonium ion. The infrared spectrum of this product is similar to that of PhP(NMe₂)₂Cl₂ except for the absence of the P-Cl stretching frequency in the region of 570-520cm⁻¹ and the presence of a band at 490cm⁻¹ (79) attributable to the P-Br stretching frequency. The elemental analysis data are listed in table 4.6:

Table 4.6

Element	Calculated for PhP(NMe ₂) ₂ Br ₂	Found
C	33.72	33.52
H	4.78	4.99
N	7.87	8.02
P	8.71	8.61
Br	44.92	44.70

These results indicate that a tetracoordinate phosphonium ion was formed and the reaction can be represented by the following equation:

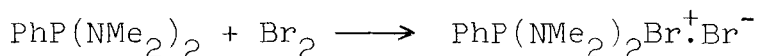

4.7 The preparation of dimethylamino dibromophosphine and bis(dimethylamino)bromophosphine

These phosphines were prepared by reacting phosphorus tribromide with dimethylamine but using different stoichiometric ratios (78) as follows:

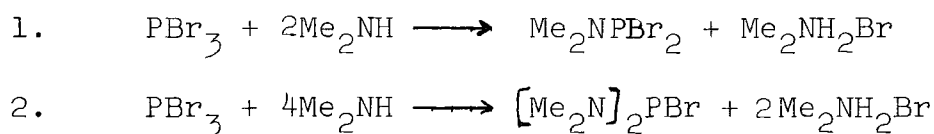

The procedures for the preparation of these phosphines were similar, consequently only the preparation of dimethylamino dibromophosphine will be described in detail.

Phosphorus tribromide (0.13 mole) was dissolved in 50 cm³ of dry degassed ether, in a three necked round bottom flask, fitted with a mechanical stirrer, a tap (connected to source of dry nitrogen) and a dropping funnel which contained dimethylamine (0.27 mole) dissolved in cold dry degassed petroleum ether (60 cm³). The flask was cooled to -83°C and the dimethylamine solution added dropwise to the phosphine solution with continuous stirring. The addition was completed after an hour and the contents of the flask were stirred at -83°C for a further 30 minutes. Then the cooling bath was removed and the stirrer kept on while the mixture

warmed to room temperature. The formation of a pale coloured solid, and an ethereal supernatant layer (containing dimethylamino dibromophosphine) was observed inside the flask. The pale yellow solid was isolated by filtration under dry nitrogen and washed three times with ether. The filtrate was placed in a clean dry conical flask, and ether was removed by evacuation leaving a pale yellow liquid, the infrared spectrum of which (thin film) is shown in figure 12. The elemental analyses results for Me_2NPBr_2 and $(\text{Me}_2\text{N})_2\text{PBr}$ are listed in table 4.7 and table 4.8:

Table 4.7

Element	Calculated for Me_2NPBr_2	Found
C	10.22	11.10
H	2.56	2.81
N	5.96	5.73
P	13.20	13.01
Br	68.06	67.92

Table 4.8

Element	Calculated for $(\text{Me}_2\text{N})_2\text{PBr}$	Found
C	24.13	23.97
H	6.03	6.40
N	14.08	14.62
P	15.59	15.33
Br	40.17	39.86

The ^{31}P nmr spectrum of Me_2NPBr_2 showed one sharp peak at -176.5 p.p.m. and the ^{31}P nmr spectrum of $(\text{Me}_2\text{N})_2\text{PBr}$ showed one sharp peak at -170.9 p.p.m. The chemical shifts of these phosphines have not been reported in the literature.

4.8 The bromination of dimethylamino dibromophosphine

A dry degassed solution of dimethylamino dibromo phosphine (39.4 mmol) prepared as described in Section 4.7 was dissolved in petroleum ether (60 cm³) and introduced into a three necked round bottom flask under dry nitrogen. A dry, degassed solution of bromine (39.1 mmol) dissolved in petroleum ether (50 cm³) was added dropwise to the phosphine solution at -6°C with continuous stirring. When the addition was complete the reactants were allowed to warm to room temperature with stirring for half an hour. The formation of a yellowish orange solid was observed, which was isolated by evaporating the solvent *in vacuo*. The solid was washed three times with petroleum ether inside the drybox. The ³¹Pnmr spectrum of the solid showed a broad peak at -12.9 p.p.m. due to the formation of a tetracoordinate phosphonium ion figure 39 , the chemical shift of this compound has not been reported previously. The infrared spectrum is shown in figure (13) and the elemental analyses data are listed in table 4.9:

Table 4.9

Element	Calculated for Me ₂ NPBr ₄	Found
C	6.08	5.79
H	1.52	1.94
N	3.55	4.01
P	7.86	7.40
Br	81.00	82.18

These results indicate that the overall reaction was simple bromination of the phosphine:

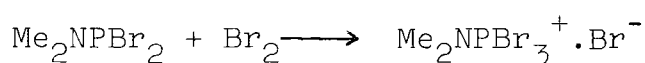

4.9 The bromination of bis(dimethylamino)bromo phosphine

In a three necked round bottom flask, a sample of bis(dimethylamino) bromophosphine (42.7 mmol) as prepared in Section 4.7) was dissolved in 50 cm³ of dry degassed petroleum ether. A solution of bromine (42.7 mmol) in dry, degassed petroleum ether (60 cm³) was added dropwise with continuous stirring under dry nitrogen to the phosphine solution (cooled to -6°C). When the addition was completed, the flask was stirred under dry nitrogen for half an hour until the contents reached room temperature. The formation of a yellow solid was observed, which was isolated by pumping off the solvent. The solid (after washing three times with petroleum ether) showed a broad peak at -45.3 p.p.m. due to the formation of a tetracoordinate phosphonium ion (figure 40); the chemical shift of this ion has not previously been reported. The infrared spectrum is shown in figure (14) and the elemental analyses are listed in table 4.10:

Table 4.10

Element	Calculated for (Me ₂ N) ₂ PBr ₃	Found
C	13.38	12.92
H	3.35	3.53
N	7.81	7.71
P	8.64	8.80
Br	66.82	66.79

These results imply that (Me₂N)₂PBr was brominated. The reaction can be represented by the following equation:

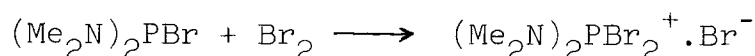

4.10 The bromination of tris(dimethylamino)phosphine

Tris(dimethylamino)phosphine (61.3 mmol) (prepared as described in Section 7.15) was dissolved in 50 cm³ of dry degassed petroleum ether, and placed in a three necked round bottom flask. A sample of bromine (61.3 mmol) was dissolved in 60 cm³ of dry degassed petroleum ether and added dropwise to the phosphine solution, while the flask contents were stirred under dry nitrogen at -6°C. After complete addition of the bromine solution the flask was warmed to room temperature over half an hour, with continued stirring. A yellowish orange solid was observed and this was isolated by evaporation of the solvent. The solid was washed three times with petroleum ether inside the drybox and pumped free of solvent *in vacuo*. The ³¹Pnmr spectrum of the solid showed one broad peak at -48.3 p.p.m. due to the formation of a tetracoordinate phosphonium ion (figure 41). This chemical shift has not been reported in the literature. The infrared spectrum of the product is shown in figure (15) and the elemental analysis are listed in table 4.11:

Table 4.11

Element	Calculated for (Me ₂ N) ₃ PBr ₂	Found
C	22.30	22.46
H	5.58	5.69
N	13.01	13.21
P	9.60	9.43
Br	49.51	48.97

These results indicate that simple bromination of the phosphine has occurred:

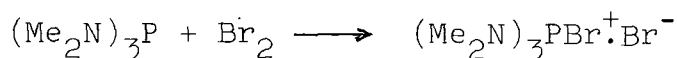

4.11 The iodination of tris(dimethylamino)phosphine

Tris(dimethylamino)phosphine (36.8 mmol) prepared as described in section 7.15, was dissolved in 45 cm³ of de-gassed dry petroleum ether (30°C - 40°C) and placed in a three necked round bottom flask under dry nitrogen. A sample of solid iodine (71.8 mmol) was added to the solution and the reactants stirred at reflux for five hours. A blackish grey solid was observed inside the flask which was isolated by evaporation of the solvent. The product was washed three times with dry ether inside the dry box and pumped dry. The ³¹Pnmr spectrum of the solid showed one broad peak at -29.2 p.p.m. due to the formation of a tetracoordinate phosphonium ion. The chemical shift of this species has not been reported in the literature. The infrared spectrum is shown in figure (16) and the elemental analyses are listed in table 4.12:

Table 4.12

Element	Calculated for (Me ₂ N) ₃ PI ₂	Found
C	17.27	16.83
H	4.32	5.02
N	10.08	10.41
P	7.44	7.40
I	60.89	60.59

These results indicate that simple iodination occurred and the overall reaction is:

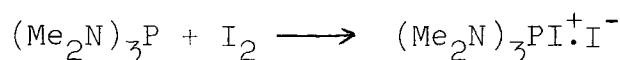

4.12 The iodination of dimethylamino dibromophosphine

Dimethylamino dibromophosphine (21.3 mmol) prepared as described in section 4.7, was dissolved in 16 cm³ of dry degassed petroleum ether inside a two necked round bottom flask. Iodine (14.1 mmol) was added to the solution which was kept under a blanket of dry nitrogen and continuously stirred. In the flask the formation of two layers was observed, a supernatant ethereal layer and a heavy dark layer. The solvent was evaporated leaving a heavy black-brown liquid, the ³¹Pnmr of which showed four peaks (assignments given in brackets) at 21.1 p.p.m. (Me₂NPBrI₂⁺.Br⁻), - 22.7 p.p.m. ((Me₂N)₂PBrI⁺.I⁻) - 176.5 p.p.m. (Me₂NPBr₂; the starting material) and - 230.6 p.p.m. due to the formation of PBr₃ (reported δ -229 p.p.m. (80)). The relative intensity for these peaks was 3:2:1:2 respectively. After three hours the ³¹Pnmr spectrum of the reaction mixture showed three peaks only at 21.1 p.p.m., -22.7 p.p.m. and at -229.3 p.p.m. The integration ratio was 1:1:1. This implied that the starting material Me₂NPBr₂ had reacted with the phosphorus species which has the chemical shift of 21.1 p.p.m. (most likely Me₂NPBrI₂⁺.Br⁻). This is concluded because the relative intensity of the peak at 21.1 p.p.m. decreased as the peak due to the starting material (at -176.5 p.p.m.) disappeared. To confirm this result about 0.5 cm³ of Me₂NPBr₂ was added to the reaction mixture. The ³¹Pnmr spectrum showed four peaks at 21.1 p.p.m. (Me₂NPBr⁺.Br⁻), -22.7 p.p.m. ((Me₂N)₂PBrI⁺.I⁻), -229.3 p.p.m. (PBr₃), and -175.2 p.p.m. (Me₂NPBr₂), the integration ratio being 1:10:9:3 respectively. This indicated that the phosphorus compound with a chemical shift of 21.1 (Me₂NPBrI₂⁺.Br⁻) reacts with Me₂NPBr₂. This reaction is

discussed in section 4.14.

4.13 The reaction between phosphorus trichloride and methyl dichloramine

A sample of phosphorus trichloride (7.9 mmol) was condensed onto a reaction vessel (figure 2.2b). Dichloromethane (4cm³) was condensed onto the phosphine solution at -196°C. The vessel was allowed to warm to room temperature and its contents were shaken to produce a homogeneous solution. The vessel was connected to the vacuum line and cooled to -196°C where the phosphine solution was degassed. Methyl dichloramine (3.1 mmol) was prepared as described in Section 2. and condensed onto the phosphine solution. The reaction vessel was held at -83°C for three hours, then it was allowed to warm to room temperature. The gas phase infrared spectrum of the most volatile fraction showed a mixture of phosphorus trichloride and dichloromethane. These were pumped away leaving a white solid. The ³¹Pnmr spectrum of this solid dissolved in dichloromethane showed two sharp peaks (i) at 79.1 p.p.m. due to the formation of (MeN=PCl₂)₂ (δ = 79.2 p.p.m.) (81) (see Figure 42), and (ii) at 87.6 p.p.m. due to the formation of a penta-coordinate covalent phosphorus compound. The latter peak may have been due to the formation of PCl₅. The ³¹Pnmr spectrum of the product was thus run without a solvent. This showed two peaks, at -85.8 p.p.m. (PCl₄⁺) and at 298.2 p.p.m. (PCl₆⁻) (see Figure 43). The infrared spectrum is shown in Figure 17. These results indicate that the reaction occurring can be written as:

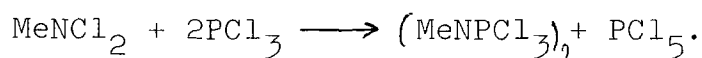

4.14 Results and discussion

The halogenation of $(\text{Me}_2\text{N})_n\text{PY}_{n-3}$ ($\text{Y} = \text{Ph}, \text{Br}$ and $n = 1, 2, 3$) with X_2 ($\text{X} = \text{Cl}$ or Br) produced phosphonium salts of the following type $(\text{Me}_2\text{N})_n\text{PY}_{n-3}\text{X}^+\text{X}^-$. To explain these results let us take as an example the chlorination of diphenyl dimethyl amino phosphine. The product of this reaction was diphenyl dimethylamino chlorophosphonium chloride which might have been formed via an $\text{S}_{\text{N}}2$ attack by the phosphorus atom on a halogen atom:

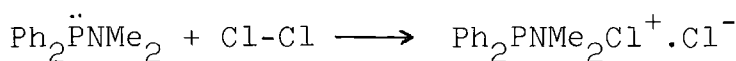

This mechanism is suggested in analogy with the mechanism proposed by Gerrard and Phillip to explain the chlorination of triisooctyl phosphite (82).

They proposed initial nucleophilic attack by the phosphorus atom on halogen, followed by an $\text{S}_{\text{N}}2$ attack by the chloride ion on the carbon atom linked to oxygen:

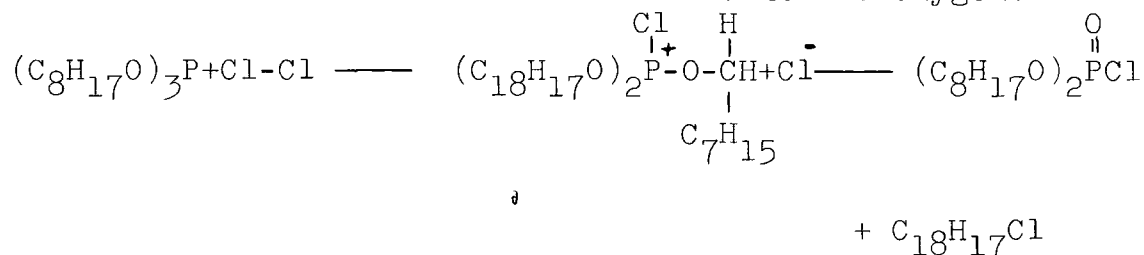

In the case of the reactions studied in this chapter the further reaction did not occur as there was no suitable nucleophilic site for the attack of the halide ion.

The results of the iodination of dimethylamino dibromo phosphine described in Section 4.12 can be represented by the following reactions:

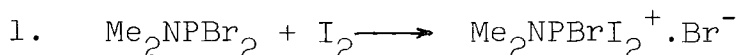

This initial product then reacted with the excess phosphine to give rearranged products.

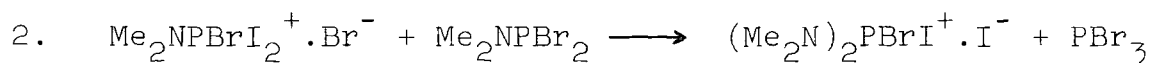

The initial product had a ^{31}P nmr chemical shift of 21.1 p.p.m. and therefore cannot be $\text{Me}_2\text{NPBr}_3^+ \cdot \text{I}^-$ because this phosphonium ion has been prepared in this work by the bromination of Me_2NPBr_2 and its chemical shift is -12.9 p.p.m. (Section 4.8). The initial product was unlikely to have been $\text{Me}_2\text{NPI}_3^+ \cdot \text{Br}^-$ as the chemical shift of this phosphonium ion is most likely to be upfield of that of the reference. If the initial product is $\text{Me}_2\text{NPBr}_2\text{I}^+ \cdot \text{I}^-$ and supposing that it reacted with Me_2NPBr in the manner shown in equation number 2 then PBr_2I was most likely to have been formed instead of PBr_3 . The chemical shift of the initial product was observed in the spectrum of the reaction between PI_3 and Me_2NBr as described in Section 5.12.

The phosphorus species which was seen as a peak at -22.7 p.p.m. could not be due to $(\text{Me}_2\text{N})_2\text{PBr}_2^+$, because the chemical shift of $(\text{Me}_2\text{N})_2\text{PBr}_2^+ \cdot \text{Br}^-$ has been reported in this work as -46.3 p.p.m. (Section 6.11). The chemical shift of -22.7 p.p.m. was unlikely to have been due to $(\text{Me}_2\text{N})_2\text{PI}_2^+ \cdot \text{Br}^-$ as this unknown phosphonium salt is more likely to have a positive chemical shift. Neither can this chemical shift be due to $(\text{Me}_2\text{N})_3\text{PBr}^+ \cdot \text{I}^-$ because the chemical shift of $(\text{Me}_2\text{N})_3\text{PBr}^+ \cdot \text{Br}^-$ has been reported in this work (Section 4.10) as -48.3 p.p.m. Consequently the chemical shift of -22.7 p.p.m. is likely to have been due to $(\text{Me}_2\text{N})_2\text{PBrI}^+ \cdot \text{I}^-$. This chemical shift was also observed in the spectrum of the reaction between PI_3 and Me_2NBr as described in Section 5.12. The third peak which appeared at -230.2 p.p.m. was due to the formation of PBr_3 .

The first spectrum of this reaction showed the peak at 21.1 p.p.m. as the major peak, with a minor peak due to the starting material Me_2NPBr_2 . The second spectrum (taken after three hours) showed three peaks, at 21.1 p.p.m., -27.7 p.p.m. and -229.3 p.p.m. with integration ratios of 1:1:1. This implies that the starting material reacted with the phosphorus compound having the chemical shift of 21.1 p.p.m. To test this some Me_2NPBr_2 was added. The repeat spectrum showed that the peak at 21.1 p.p.m. became a minor one and the major peaks were at -27.7 p.p.m. and -229.2 p.p.m. with a fourth peak at -175.6 p.p.m. due to the excess of Me_2NPBr_2 added. This result implies that Me_2NPBr_2 reacted with the initial product until the reaction reached equilibrium.

The reaction between phosphorus trichloride and methyl dichloramine produced $(\text{MeN}=\text{PCl}_3)_2$ and phosphorus pentachloride. A likely mechanism for this reaction is:

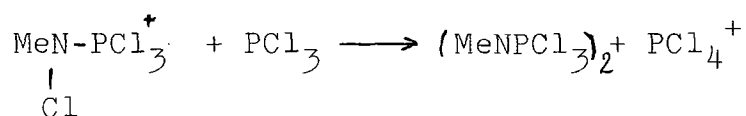
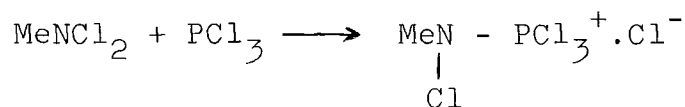

The ^{31}P nmr spectrum of the product dissolved in methyl chloride (figure 42) showed two peaks at 79.1 p.p.m., due to $(\text{MeN}=\text{PCl}_3)_2$ (81) and 85.5 p.p.m. due to PCl_5 . The ^{31}P nmr spectrum of the solid product showed two peaks at -85.9 p.p.m. due to PCl_4^+ and 298.2 due to PCl_6^- , the integration ratio of the two peaks being 1:1.

CHAPTER FIVE

THE REACTIONS OF HALAMINES WITH
THE PHOSPHORUS TRIHALIDES

5.1 Introduction

The reactions of halamines and phosphorus trihalides have not received much attention in the literature. The work done in this area comprises of only two reactions, namely the reaction between nitrogen trichloride and phosphorus trichloride which gives $(\text{Cl}_3\text{-P-N}=\text{PCl}_3)^+\text{.PCl}_6^-$; and the reaction between dimethylchloramine and excess trichloride (carried out in this laboratory (1)) which can be represented by the equation:



The complexity of this reaction produced an interest in reacting the phosphorus trihalides with various halamines.

5.2 The reaction of phosphorus trichloride with excess dimethylchloramine

A sample of dry, degassed dimethylchloramine (7.4 mmol) was condensed into a modified nmr tube. Onto this was condensed 3cm^3 of dry, degassed dichloromethane and the tube was allowed to warm to room temperature so that it could be shaken to form a homogeneous solution. Degassed phosphorus trichloride (3.1 mmol) was condensed onto this solution at -196°C . After the tube had been kept at -23°C with occasional shaking for five hours, it was allowed to warm to room temperature. The gas phase infrared spectrum of the most volatile fraction showed a mixture of dimethylchloramine and dichloromethane. A white precipitate was formed which was found to be insoluble in dichloromethane acetonitrile and nitrobenzene. The ^{31}P nmr spectrum of this solid showed three peaks: a broad one at -51.6 p.p.m. due to the formation of $(\text{Me}_2\text{N})_2\text{PCl}_2^+$ which

has been prepared by reacting Me_2NCl with Me_2NPCl_2 (1). The second peak appeared as a shoulder on the first one at -56.4 p.p.m. due to the formation of $\text{Me}_2\text{NPCl}_3^+$. (1). The final peak was a broad one at 298.2 p.p.m. due to the formation of PCl_6^- (it was difficult to measure the integration ratio, because of the poor resolution of the two peaks at -56.4 p.p.m. and -51.6 p.p.m.). This result implies that the reaction can be written as:

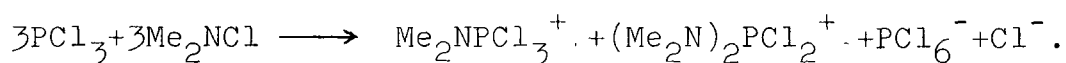

After the product had been hydrolysed by exposure to wet nitrogen for twelve days it was noted that most of the sample had been converted to a colourless liquid. Chloroform (2 cm^3) was added to the sample and the $^{31}\text{Pnmr}$ spectrum of the solution (figure 44) showed two sharp, minor peaks at -58.6 p.p.m. due to unhydrolysed $\text{Me}_2\text{NPCl}_3^+.\text{Cl}^-$ and at -51.6 p.p.m. due to unhydrolysed $(\text{Me}_2\text{N})_2\text{PCl}_2^+.\text{Cl}^-$. This spectrum showed three other sharp peaks at -32.1 p.p.m. due to the formation of $(\text{Me}_2\text{N})_2\text{POCl}$ (2.2b) (produced as a result of hydrolysis of $(\text{Me}_2\text{N})_2\text{PCl}_2^+$).

A second peak was observed at -19.1 p.p.m. due to the formation of $\text{Me}_2\text{NPOCl}_2$ (51) which was produced as a result of hydrolysis of $\text{Me}_2\text{NPCl}_3^+$. A third peak was noted at -1.6 p.p.m. due to the formation of POCl_3 (83) which was produced by the hydrolysis of PCl_6^- .

These hydrolysis further confirm the above equation for the reaction of phosphorus trichloride with excess dimethyl chloramine.

5.3 The reaction between phosphorus trichloride and $\text{Me}_2\text{NPCl}_3^+$

This reaction was performed to help to elucidate the reaction described in section 5.2. A sample of the mixture (0.41g) $\text{Me}_2\text{NPCl}_3^+$, $(\text{Me}_2\text{N})_2\text{PCl}_2^+$, PCl_6^- , Cl^- obtained as described in section 5.2, was placed inside a reaction vessel (figure 2.26) and 2 cm³ of dry degassed dichloromethane was condensed onto it. The vessel was shaken continuously at room temperature for 10 minutes. Then 3 cm³ of degassed phosphorus trichloride was condensed onto this slurry at -196°C. The vessel was allowed to warm to room temperature, but there was no indication that any reaction was occurring. The vessel was kept at room temperature for two hours, with occasional shaking. The gas phase infrared spectrum of the most volatile fraction showed a mixture of phosphorus trichloride and dichloromethane. These were pumped away leaving a white solid which had a similar ³¹Pnmr spectrum to that of the original mixture, implying that the exchange reaction had not occurred:

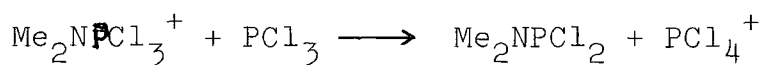

5.4 The reaction between phosphorus tribromide and dimethyl bromamine

A sample of dry degassed dimethyl bromamine (prepared as in section 2.9.3) was condensed onto 8.7 mmol of phosphorus tribromide dissolved in 3 cm³ of petroleum ether in a reaction vessel (Figure 2.2b) at -196°C. The reactants were kept at -32°C (the freezer temperature) for seven hours and then the cell was connected to the vacuum line and allowed to warm to room temperature. The gas phase infrared spectrum of the

most volatile fractions showed a mixture of dimethyl bromamine and petroleum ether. These were evaporated, leaving an orange solid inside the vessel. The product was washed three times with petroleum ether inside the dry-box. The ^{31}P nmr spectrum of the solid product showed one broad peak at -13.1 p.p.m. This chemical shift (within experimental error) is identical to that found for $\text{Me}_2\text{NPBr}_3^+.\text{Br}^-$ prepared as described in section 4.8. The infrared spectrum (Figure 13) showed the characteristic peak for the phosphorus nitrogen bond at 720 cm^{-1} (84). The elemental analysis results are shown in Table 5.1.

Table 5.1

Table 5.1

Element	Calculated for Me_2NPBr_4	Found
C	6.1	6.31
H	1.5	2.10
N	3.55	3.27
P	7.86	7.53
Br	81.00	81.72

These results indicate that the product of the reaction was $\text{Me}_2\text{NPBr}_3^+.\text{Br}^-$ and that the reaction was a simple amination of the phosphorus atom:

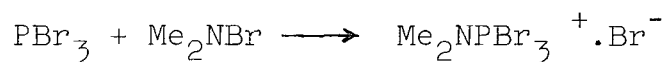

5.5 The reaction between phosphorus tribromide and dimethyl chloramine

A dry degassed sample of dimethyl chloramine (8.2 mmol) was distilled into 5.5 mmol of phosphorus tribromide dissolved in 3 cm³ of dry degassed petroleum ether inside a reaction vessel (Figure 2.2b) at -196°C. The cell was allowed to warm to -37°C (the freezer temperature) for five hours and then warmed to room temperature. The gas phase infrared spectrum of the vessel contents showed a mixture of dimethyl chloramine and petroleum ether. A yellowish-white solid was left inside the vessel, after the volatile substances had been pumped away. The product was found to be hygroscopic and was washed with petroleum ether three times. One broad peak at -54.6 p.p.m. was found in the ³¹Pnmr spectrum of this solid (figure 45). The infrared spectrum showed the formation of the phosphorus nitrogen bond by the presence of a peak at 720 cm⁻¹ (Figure 18) (84). The elemental analysis results are given in Table 5.2.

Table 5.2

Element	Calculated for Me ₂ NPClBr ₃	Found
C	6.85	6.17
H	1.70	2.01
N	4.00	3.88
P	8.85	8.96
Br	68.50	68.10
Cl	10.10	9.98

The elemental analysis results imply that the product has the following molecular formula Me₂NPClBr₃, and the ³¹Pnmr result indicates that the product is a phosphonium ion and

it is not $\text{Me}_2\text{NBr}_3^+\cdot\text{Cl}^-$, because the chemical shift of this phosphonium ion was found as -13.1 p.p.m. as described in section 5.4, thus the produce is likely to be $\text{Me}_2\text{NPClBr}_2^+\cdot\text{Br}^-$ and the overall reaction is most probably as the following:

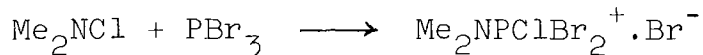

To confirm that the product is a bromide phosphonium salt the following two experiments were carried out.

5.6 The reaction between $\text{Me}_2\text{NPClBr}_3$ and boron tribromide

Boron tribromide (4 cm^3) was condensed onto 5.3 mmol of $\text{Me}_2\text{NPClBr}_3$ at -196°C inside a reaction vessel (Figure 2.2b). The reactants were kept at -32°C (the freezer temperature) for five hours. The vessel was allowed to warm to 0°C and the gas phase infrared spectrum showed the presence of boron tribromide only, which was pumped away leaving a yellowish-orange solid inside the cell. This solid was washed with petroleum ether three times and the $^{31}\text{Pnmr}$ spectrum of the solid showed one broad peak only at -54.2 p.p.m. due to the presence of the same tetra coordinate phosphonium ion produced by the reaction in the previous section. The infrared spectrum showed a broad band in the range of 700 cm^{-1} : 750 cm^{-1} , but the spectrum was not clear enough to decide whether this band was due to BBr_4^- or BBr_3Cl^- .

5.7 The reaction between $\text{Me}_2\text{NPClBr}_3$ and phosphorus pentachloride

A sample of $\text{Me}_2\text{NPClBr}_3$ (4.4 mmol) was dissolved in 5 cm^3 of dry degassed dichloromethane inside a modified Pnmr

tube (Figure 2.5) inside the dry box. Phosphorus pentachloride (7.2 mmol) was added to this solution and the Pnmr tube was sealed and shaken vigorously for two hours. Three peaks were found in the $^{31}\text{Pnmr}$ spectrum (Figure 46), one at -219.3 p.p.m. corresponding to PCl_3 (57), a second at -54.1 p.p.m. (due to the phosphonium ion produced in section 5.5) and a third at 298 p.p.m. due to PCl_6^- ; in the ratio 1:2:2 approximately. The colour of the solution inside the tube was brown, indicating the presence of bromine. K.B. Dillon and his co-workers (85) have proved that if a bromide salt is reacted with an excess of phosphorus pentachloride ^{then} bromine, hexachlorophosphate and phosphorus trichloride will be produced. In the reaction described in this section bromine and phosphorus trichloride have been found, thus it is likely that the salt formed in section 5.5 is the bromide salt of dimethylaminodibromo chlorophosphonium ion and that the reaction occurring on addition of phosphorus pentachloride is:

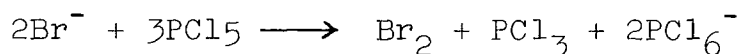

Thus the chloramination reaction that is described in section 5.5 can be written as:

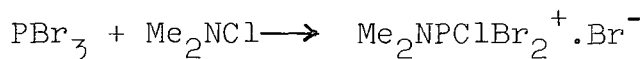

This represents not only amination of the phosphorus, but also exchange of one of the halogens.

Presumably the reaction that is described in section 5.6 was the formation of the tetrabromoborate:

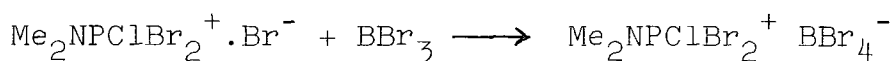

5.8 The reaction between phosphorus trichloride and dimethyl bromamine

A dry degassed sample of dimethyl bromamine (12.0 mmol) was condensed onto 19.6 mmol of degassed phosphorus trichloride dissolved in 3 cm³ of dry degassed petroleum ether inside a reaction vessel (Figure 2.2b) at -196°C. The tube was kept at -32°C (the freezer temperature) for twenty hours. After the vessel had been allowed to warm to room temperature, the gas phase infrared spectrum showed a mixture of petroleum ether and phosphorus trichloride. The volatile substances were pumped away leaving a white substance inside the vessel. A sample of the product was transferred under dry nitrogen into a Pnmr tube. The spectrum of the solid (Figure 47) showed three peaks:

- (1) A sharp peak at -175.2 p.p.m. which (within experimental error) corresponds to the chemical shift found for Me₂NPBr₂ as described in section 4.7);
- (2) A broad peak at -58.6 p.p.m. corresponding to Me₂NPCl₃⁺ (1); and
- (3) A broad peak at 301.1 p.p.m. due to the formation of PCl₆⁻ (86).

The relative intensity of the three peaks was 1:2:1. The product was washed with petroleum ether three times to remove Me₂NPBr₂ and the white solid remaining showed two peaks in the ³¹Pnmr spectrum at -58.6 p.p.m. and 301.3 p.p.m. (intensity ratio 2:1). The infrared spectrum of this solid was very similar to the infrared spectrum of 2Me₂NPCl₃⁺, PCl₆⁻, Cl⁻ (1) (Figure 19).

The elemental analysis results are shown in Table 5.3.

Table 5.3

Element	Calculated for (Me ₂ N) ₂ P ₃ BrCl ₁₂	Found
C	7.00	6.85
H	1.15	1.83
N	4.09	4.25
P	13.55	13.49
Br	61.90	60.41
Cl	11.65	11.27

These results indicate that the overall reaction was:

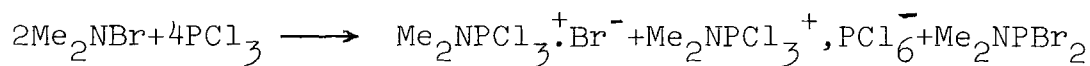

5.9 The preparation of phosphorus trifluoride

Phosphorus trifluoride was prepared as described by Booth and Bozarth by reacting antimony trifluoride with phosphorus trichloride using antimony pentachloride as a catalyst (87):

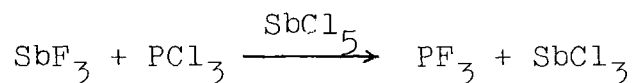

The purity of phosphorus trifluoride produced was checked by comparing its gas phase infrared spectrum with an authentic spectrum of the phosphine. The phosphine was stored in one of the bulbs of the fractionation section of the vacuum line (Figure 2.1) at liquid air temperature.

5.10 The reaction between phosphorus trifluoride and dimethylchloramine

Phosphorus trifluoride (23.9 mmol) as prepared in Section 5.9 was degassed and condensed onto 2 cm³ of dichloromethane inside a silica nmr tube containing a constriction. A dry degassed sample of dimethylchloramine (38.6 mmol) was condensed onto this solution at -196°C and the tube sealed and allowed to warm to -23°C. After one hour the colour of the contents was pale green. The ³¹Pnmr spectrum (Fig.47) showed four sets of peaks (i) a triplet centred at -21.1 p.p.m. (J = 1069 Hz) due to the formation of a tetra co-ordinate phosphonium ion, presumably (Me₂N)₂PF₂⁺, this triplet also appeared in the spectrum of the reaction between Me₂NC1 and Me₂NPF₂ (Figure 57); (ii) a heptet centred at 145.1 p.p.m. (J = 712 Hz) due to the formation of a PF₆⁻ (88); (iii) a sextet centred at 146.8 p.p.m. (J = 796 Hz) due to the formation of a hexa co-ordinate phosphate ion, where five fluorine atoms are attached to the phosphorus, there are two possibilities for this system, PClF₅⁻ and Me₂NPF₅⁻ but the first ion is known and its chemical shift is reported as 138 p.p.m. (J = 860 cps) (89), thus it is likely that the ion is Me₂NPF₅⁻; (iv) a triplet centred at 30.7 p.p.m. (J = 980 Hz) due to the formation of the known PF₂Cl₃ molecular species (90). Since the ³¹Pnmr spectrum of the produce showed the presence of the four phosphorus species (described above) then it is possible to represent this reaction by the following equation:

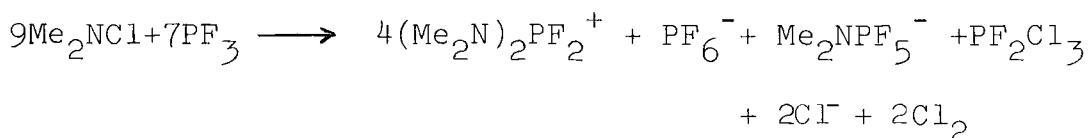

5.11 The reaction between phosphorus trifluoride and dimethylbromamine

Phosphorus trifluoride (17.1 mmol) as prepared in Section 5.9 was degassed and condensed on to 3 cm³ of dry degassed dichloromethane inside a silica nmr tube, (figure 2.5). A dry degassed dimethylbromamine sample (42.7 mmol) was condensed onto the phosphorus trifluoride solution and the tube was sealed off and warmed to -23°C (carbon tetrachloride cooled bath). After an hour the reaction mixture had turned brown. The ³¹Pnmr spectrum (figure 48) showed two sets of peaks: (i) a doublet centred at -41.2 p.p.m. (J = 976.5 Hz), this chemical shift is very close to the chemical shift of (Me₂N)₃PF⁺.Cl⁻ prepared by reacting (Me₂N)₂PF with Me₂NCl as described in Section 5.15; (ii) a sextet centred at 148.3 p.p.m. (J = 782.1 cps) which is very close to the chemical shift of Me₂NPF₅⁻ noted in the spectrum of the product of the reaction between phosphorus trifluoride and dimethyl chloramine, Section 5.10.

Then according to the ³¹Pnmr spectrum which shows the presence of the species described above, it is possible to represent this reaction by the following equation:

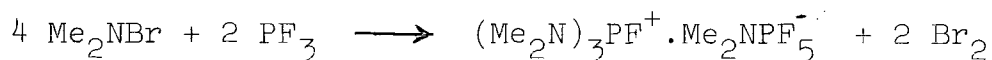

5.12 The preparation of phosphorus triiodide

Phosphorus triiodide was prepared by reacting phosphorus trichloride with potassium iodide (91) as follows: Inside a two-necked round bottomed flask and under an atmosphere of dry nitrogen, potassium iodide (30g) was made into a slurry with 50cm³ of dry diethylether. Phosphorus trichloride (5cm³) was added and the reaction mixture was refluxed for 20 hours. The ether was then removed under vacuum and the phosphorus triiodide extracted with carbon disulphide. After the carbon disulphide had been pumped away a reddish solid remained. The ³¹Pnmr spectrum of the solid dissolved in carbon disulphide showed one major peak at -177.0 p.p.m. due to phosphorus triiodide and a minor peak at -109.1 p.p.m. due to tetra iodobiphosphine. The integration ratio of the two peaks was 100:8. Tetra iodobiphosphine is generally produced as impurity when phosphorus triiodide is prepared.

5.13 The reaction between phosphorus triiodide and dimethylchloramine

This reaction was carried out four times as shown in Table 5.4. Carbon disulphide was used as a solvent for phosphorus triiodide. Dry dimethyl chloramine was degassed and condensed onto this solution inside a modified nmr tube (Figure 2.5). In each case the tube was connected to the vacuum line and the gas phase infrared spectrum determined. The vapour from the first experiment showed the presence of carbon disulphide only, while the spectra of the other experiments showed the presence of a mixture of dimethyl chloramine and carbon disulphide. These were pumped away leaving compounds as described in Table 5.4. The chemical shift of

the final product of the fourth experiment is similar to that found for $(\text{Me}_2\text{N})_3\text{PCl}^+\cdot\text{Cl}^-$ ($\delta = -53.3$ p.p.m. (1)). Thus it is likely that complete oxidation of all the P-I bonds had occurred.

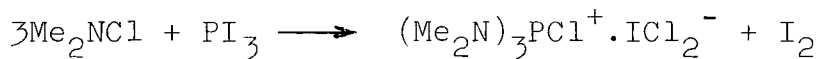

The presence of the iodide was implied by the dark metallic colour of the product.

5.14 The reaction between phosphorus triiodide and dimethylbromamine

This reaction was carried out using the same technique as described in the previous section. Phosphorus triiodide was dissolved in carbon disulphide and dimethylbromamine was degassed before it was condensed onto the solution at -196°C . This reaction was performed four times under different conditions as shown by Table 5.5. The gas phase infrared spectrum of the product of reaction No.1 showed the presence of carbon disulphide only, while the gas phase infrared spectrum of the volatile fractions of the other reactions showed a mixture of carbon disulphide and dimethyl bromamine. These were pumped away leaving substances as described in Table 5.5. The conditions and the ^{31}P nmr spectra of these reactions are shown in Table 5.5. The chemical shift of the final product of the fourth experiment is -48.3 p.p.m. This chemical shift is consistent with that of $(\text{Me}_2\text{N})_3\text{PBr}^+\cdot\text{Br}^-$ prepared by the bromination of $(\text{Me}_2\text{N})_3\text{P}$ as described in Section 4.10 ($\delta = -48.3$ p.p.m.). Thus it is probable that complete oxidation occurred for all the P-I bonds:

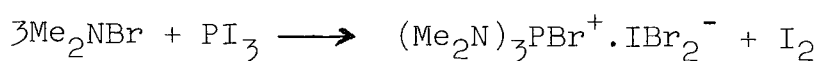

5.15 The reaction between tetra iodobiphosphine and dimethyl chloramine

Tetra iodo biphosphine was made by Dr. A. Platt using the method of M. Baudler.(92) The ^{31}P nmr spectrum showed the presence of about 6% phosphorus triiodide. The reactions of the biphosphine with the chloramine were carried out four times applying the same technique used for the phosphorus triiodide reactions. Carbon disulphide was used as a solvent. The conditions and the spectra of these reactions are shown in Table 5.6. The gas phase infrared spectrum of the most volatile fraction of the first reaction showed the presence of carbon disulphide only, while in the case of the other reactions a mixture of dimethyl chloramine and carbon disulphide was seen. These were pumped away leaving substances as described in Table 5.6. These reactions will be discussed in Section 5.17.

5.16 The reaction between tetra iodobiphosphine and dimethyl bromamine

This reaction was performed four times by employing the same technique used in Section 5.13. The conditions and the spectra of these reactions are shown in Table 5.7. The gas phase infrared spectrum of the most volatile fraction of the first reaction showed the presence of carbon disulphide only, while the spectra of the other three reactions showed a mixture of dimethyl bromamine and carbon disulphide. These were pumped away leaving substances as described in Table 5.7. These reactions will be discussed in Section 5.17.

Table 5.4

The conditions and spectra of the reactions between
phosphorus triiodide and dimethylchloramine

No.	Molar Ratio $\text{Me}_2\text{NCl}/\text{PI}_3$	Temp. $^{\circ}\text{C}$	Time Min.	Pnmr/p.p.m.			Integrat- ion ratios	Fig. 50	Appearance	
1	0.58	-23.0	30	0.0	-177.5	-208.4	-185.3	6: 2.5:1:1	50.a	an orange solid
2	1.95	-45.0	20	0.0			-27.4	1:15	50.b	a brown oily substance
3	2.53	-45.0	10	0.0			-27.4	1:10:8	50.c	blackish brown oil substance
4	4.61	-45.0	15				-27.4	1:3	50.d	blackish brown oily substance mixed with iodine looking powder
	4.61	-23.0	50				-53.3	-53.3	50.e	

Table 5.5

The conditions and spectra of the reactions between
phosphorus triiodide and dimethyl bromamine

No.	Molar Ratio $\text{Me}_2\text{NBr}/\text{PI}_3$	Temp. $^{\circ}\text{C}$	Time Min.	Pnmr/p.p.m.	Inte- gration ratios	Fig.	Appearance
1	0.63	-23.0	35	21.0 -177.3 -208.1 -185.3	9:5:3:1	51.a	an orange solid
2	1.79	-45.0	30	21.0 -21.1	1:7	51.b	dark brown oily substance
3	2.81	-45.0	15	21.0 -21.1 -48.3	1:3:1	51.c	black brownish oily substance
4	4.36	-45.0	25	21.0 -21.1 -48.3	1:2	51.d	black brownish oily substance mixed with iodine looking powder
		-23.0	75	-48.3		51.e	

Table 5.6

The conditions and spectra of the reactions
between P_2I_4 and Me_2NCl

No.	Molar Ratio Me_2NCl/P_2I_4	Temp. $^{\circ}C$	Time Min.	Pnmr/p.p.m.						Integration ratios	Fig. 52	Appearance	
1	0.73	-23.0	10	-208.4	-185.5	-109.1	-177.5				6:6:2:1	52.a	an orange solid
2	2.42	-45.0	15			0.0	-27.4				2:1	52.b	a brownish oily substance
3	4.61	-45.0	15			0.0	-27.4	53.3			1:5:2	52.c	blackish red oily substance
4	6.95	-23.0	20								1:6	52.d	blackish red oily substance
	6.95	-23.0	40									52.e	mixed with iodine looking powder

Table 5.7

The conditions and spectra of the reactions
between P_2I_4 and Me_2NBr

No.	Molar Ratio Me_2NBr/P_2I_4	Temp. $^{\circ}C$	Time Min.	Pnmr/p.p.m.						Integration ratios	Fig. 53	Appearance	
1	0.69	-23.0	15	-208.2	-185.3	-177.5	-109.1				5:4:1:2	53.a	an orange solid
2	2.35	-45.0	20				21.0	-21.1			1:3	53.b	a deep brown oily substance
3	4.52	-45.0	20				21.0	-21.1	-48.3		2:5:1	53.c	blackish brown oily substance
4	6.38	-45.0	15					-21.1	-48.3		1:2	53.d	brownish black oily substance with iodine looking powder
	6.38	-23.0	50						-48.3			53.e	

5.17 Discussion of the reactions described in Sections 5.13, 5.14, 5.15 and 5.16

The reactions between PI_3 and Me_2NCl are listed in Table 5.4. The ^{31}P nmr spectrum of the first reaction showed a major peak at 0.0 p.p.m. which is likely to be due to the formation of $\text{Me}_2\text{NPClI}_2^+.\text{I}^-$. It is unlikely to be due to the formation of $\text{Me}_2\text{NPI}_3^+.\text{Cl}^-$ because the chemical shift of the latter would be positive considering the chemical shift of $\text{Me}_2\text{NPBr}_3^+.\text{Br}^-$ which is -12.9 p.p.m., and it is known that replacing bromine atoms with iodine atoms will bring the *resonance upfield* of that of the reference. Two minor peaks were observed in the spectrum which could be due to the side reaction between Me_2NCl and P_2I_4 which was found as an impurity in PI_3 . One peak was at -208.4 p.p.m. which is close to the reported value for PI_2Cl ($\delta = -208$ p.p.m.) (93) and the second at -185.3 p.p.m. which is close to the chemical shift of Me_2NPI_2 (94). The fourth peak at -177.5 p.p.m. is due to excess PI_3 .

The ^{31}P nmr spectrum of the second reaction did not show an excess of PI_3 but a minor peak at 0.0 p.p.m., which could be due to unreacted $\text{Me}_2\text{NPClI}_2^+.\text{I}^-$, whilst the peak at -27.4 p.p.m. was the major one. This could indicate that the suggested initial product $\text{Me}_2\text{NPClI}_2^+.\text{I}^-$ (0.0 p.p.m.) reacted with a second molecule of Me_2NCl :

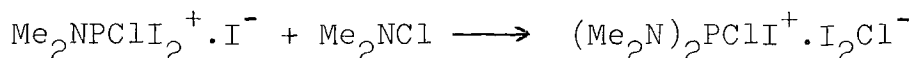

The peak at -27.4 p.p.m. is likely to be due to the formation of $(\text{Me}_2\text{N})_2\text{PClI}^+$ and not due to the formation of $(\text{Me}_2\text{N})_2\text{PCl}_2^+$, because the chemical shift of the latter was reported as -51.6 p.p.m. (1). Also this chemical shift of -27.4 p.p.m. is not likely to be due to the formation of $(\text{Me}_2\text{N})_2\text{PI}_2^+$, which would have a positive chemical shift considering that the

chemical shift of $(\text{Me}_2\text{N})_2\text{PBr}_2^+ \cdot \text{Br}^-$ is -46.3 p.p.m. (as reported in Section 4.9). In the third reaction the ^{31}P nmr spectrum showed the same two peaks as the second reaction. In this case, however, rather more of the $\text{Me}_2\text{NPClI}_2^+$ had reacted as in this case more chloramine had been used. The spectrum of the fourth reaction initially showed two peaks, one at -27.4 p.p.m., as seen in reactions 2 and 3, due to $(\text{Me}_2\text{N})_2\text{PICl}^+$ and one at -53.3 p.p.m. which has the same chemical shift as has been observed for $(\text{Me}_2\text{N})_3\text{PCl}^+ \cdot \text{Cl}^-$ prepared by the reaction of $(\text{Me}_2\text{N})_2\text{PCl}$ with Me_2NCl (1). After this mixture had been at room temperature for a further 35 minutes the nmr spectrum showed only one peak at -53.3 p.p.m. indicating that the removal of the final iodine atom from the phosphonium occurs slowly. These results show that the reaction between PI_3 and Me_2NCl is not a one-step reaction but occurs in a series of reactions:

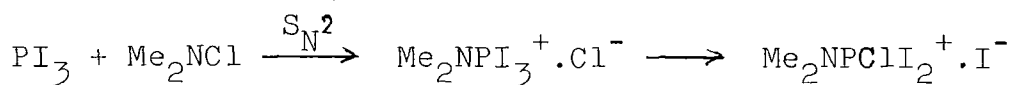

Then this iodo phosphonium salt reacts with another molecule of Me_2NCl to replace the iodine atom attached to the phosphorus by a dimethyl amino group:

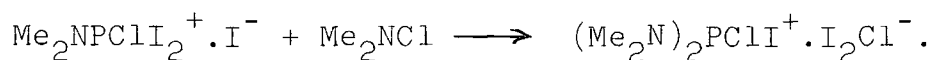

Then $(\text{Me}_2\text{N})_2\text{PClI}^+ \cdot \text{I}_2\text{Cl}^-$ reacts further with Me_2NCl :

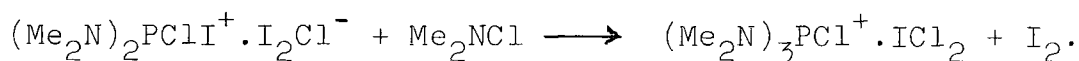

The side reaction between Me_2NCl and P_2I_4 which was found as an impurity will be discussed later.

The reactions between PI_3 and Me_2NBr can be represented as a similar set of reactions to those mentioned in the chloramine case above:



Compounds can then react further with Me_2NBr and thus the intensity of the peaks at 21.0 p.p.m. decreased, while the other phosphonium ion formed showing a peak at -21.1 p.p.m.:

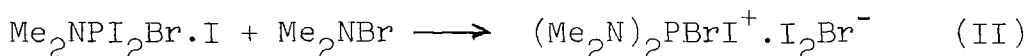

The chemical shift of -21.1 p.p.m. was also noted when Me_2NPBr_2 was iodinated, and it was thought to be due to the formation of $(\text{Me}_2\text{N})_2\text{PBrI}^+ \cdot \text{I}^-$ as described in Section 4.14.

The compound $(\text{Me}_2\text{N})_2\text{PIBr}^+ \cdot \text{I}_2\text{Br}$ presumably reacted further with Me_2NBr and the dimethylamino group replaced the last iodine atom linked to the phosphorus:

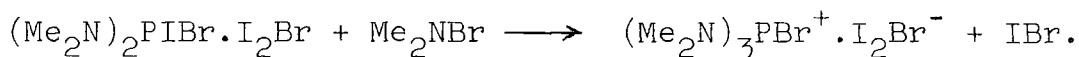

The formation of $(\text{Me}_2\text{N})_3\text{PBr}^+$ is indicated by the spectrum of the fourth experiment which showed one peak only at -48.3 p.p.m. due to the formation of $(\text{Me}_2\text{N})_3\text{PBr}^+$, the chemical shift of which has been reported in Section 4.10. The formation of IBr was indicated by the black colouration and the black solid suspended in the heavy oil. Neither the infrared spectra nor the Raman spectra of the products of these reactions have been studied due to the difficulty of isolating the compounds from the product mixture and as far as Raman is concerned due to the dark colour of the product.

The reactions between P_2I_4 and Me_2NCl are listed in Table 5.6. The ^{31}P nmr spectrum of the first reaction shows four peaks, one at -208.4 p.p.m. due to the formation of PI_2Cl ($\delta = -208.0$ p.p.m. (93)); the second peak at -185.5 p.p.m. due to the formation of Me_2NPI_2 (94); the third peak at -109.1 p.p.m. is due to P_2I_4 (which was used in excess) and the fourth peak at -177.5 p.p.m. is due to PI_3 (which was

found as an impurity). This suggests that the reaction is a simple oxidation by the cleavage of P-P bond:

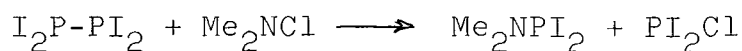

This reaction is similar to the reported cleavage of P-P bonds by alkylating agents (95):

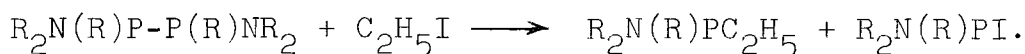

The ^{31}P nmr spectrum of the second reaction showed two peaks only at 0.0 p.p.m. and at -27.4 p.p.m. these peaks have been observed in the spectrum of the reaction between Me_2NCl and PI_3 (Table 5.4). The peak at 0.0 p.p.m. was thought to be due to Me_2NPI_2Cl . and the one at -27.4 p.p.m. due to $(Me_2N)_2PClI^+$. as has been discussed above. These two phosphonium ions could be formed by the cleavage of the P-P bond as described above, followed by the amination of the two P(III) products:

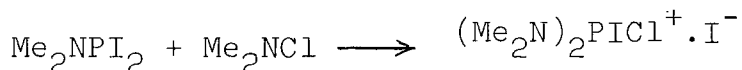
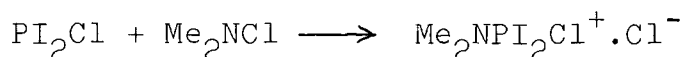

In the compound $Me_2NPI_2Cl^+.Cl^-$ an exchange of halogen atom could occur to produce $Me_2NPICl_2^+.I^-$, but it seems as if the reaction between $Me_2NPI_2Cl^+.Cl^-$ and dimethyl chloramine is faster and the appearance of new phosphorus species was not shown by the ^{31}P nmr spectrum:

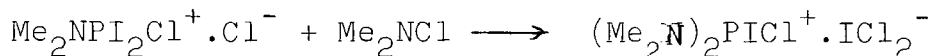

while $(Me_2N)_2PClI^+.I^-$ reacted with Me_2NCl as follows:

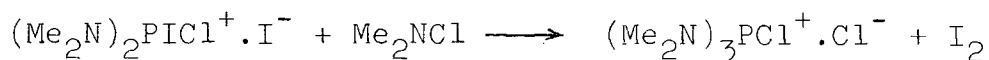

Thus the ^{31}P nmr spectrum of the third reaction showed two peaks, a minor one at -27.4 p.p.m. ($(Me_2N)_2PClI^+.ICl_2^-$) and

a second peak being the major one at -53.3 p.p.m. This chemical shift is identical to the chemical shift observed for $(\text{Me}_2\text{N})_3\text{PCl}^+\cdot\text{Cl}^-$ ($\delta = -53.3$ p.p.m. (1)). The $^{31}\text{Pnmr}$ spectrum of the fourth reaction showed one peak only at -53.3 p.p.m. due to $(\text{Me}_2\text{N})_3\text{PCl}^+$ indicating that the chloramine has completed the oxidation of the last P-I bond in the previous two phosphonium ions:

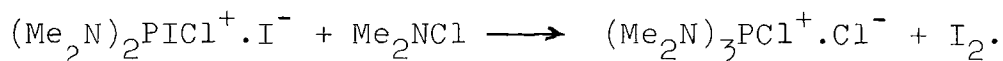

The reactions between P_2I_4 and Me_2NBr parallels the reaction between P_2I_4 and Me_2NCl . The $^{31}\text{Pnmr}$ spectrum of the first reaction (Table 5.7), showed four peaks: one at -208.4 p.p.m. due to the formation of the known compound PI_2Br ($\delta = 208.2$ p.p.m. (96)); the second peak at -185.3 p.p.m. due to the formation of Me_2NPI_2 (94); the third peak at -109.1 p.p.m. due to P_2I_4 which was used in excess; and the fourth peak at -177.5 p.p.m. is due to PI_3 which was found as an impurity in the starting material. This result indicates that the reaction was simple oxidation by the cleavage of the P-P bond as shown in the following equation:

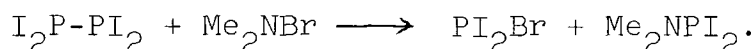

The $^{31}\text{Pnmr}$ spectrum of the second reaction (Table 5.7) showed two peaks at -21.1 p.p.m. and 21.0 p.p.m. these peaks were observed in the spectrum of the reaction between Me_2NPBr_2 and iodine (Section 4.12). The assignment of the peaks at 21.0 p.p.m. and -21.1 p.p.m. as $\text{Me}_2\text{NPI}_2\text{Br}^+$ and $(\text{Me}_2\text{N})_2\text{PIBr}^+$ respectively has been discussed in Section 4.14. These

phosphonium ions could well have been formed according to the following equations:

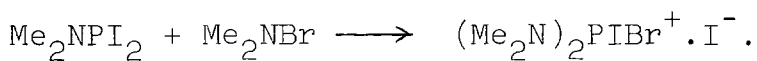
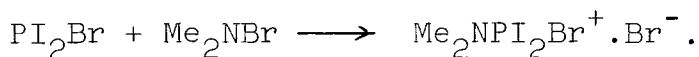

In the compound $\text{Me}_2\text{NPI}_2\text{Br}^+ \cdot \text{Br}^-$ the exchange of halogens seems not to occur to produce $\text{Me}_2\text{NPIBr}_2^+ \cdot \text{I}^-$, because, if this kind of halogen exchange occurred, then $\text{Me}_2\text{NPBr}_3^+ \cdot \text{I}^-$ could be produced and the latter was not observed in any of the spectra. It seems that the P-I bonds were replaced by P-NMe₂ bonds to produce $(\text{Me}_2\text{N})_3\text{PBr}^+$ in both $\text{Me}_2\text{NPI}_2\text{Br}^+$ and $(\text{Me}_2\text{N})_2\text{PIBr}^+$. This assumption is supported by the ³¹Pnmr spectrum of the third reaction as shown in Table 5.7, where the peaks were observed; a minor one at -21.1 p.p.m. ($(\text{Me}_2\text{N})_2\text{PIBr}^+$) and a major peak at -48.3 p.p.m. which is identical to the chemical shift found for $(\text{Me}_2\text{N})_3\text{PBr}^+ \cdot \text{Br}^-$ (-48.3 p.p.m., Section 4.10).

The ³¹Pnmr spectrum of the fourth reaction which contained excess Me_2NBr (Table 5.7) shows one peak only at -48.3 p.p.m. which is due to the formation of $(\text{Me}_2\text{N})_3\text{PBr}^+$. This indicates that all the iodine atoms linked to the phosphorus have been replaced by dimethyl amino groups:

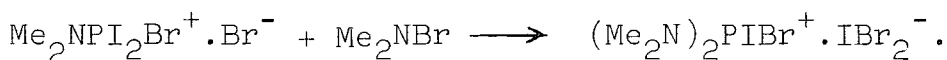

Thus a further replacement of P-I bond by P-NMe₂ bond:

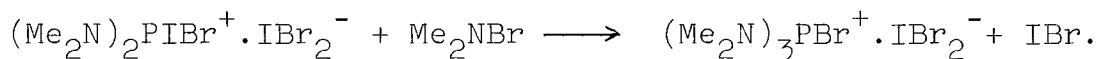

While the other phosphonium salt produced from the reaction between Me_2NPI_2 and Me_2NBr ($(\text{Me}_2\text{N})_2\text{PIBr}^+ \cdot \text{I}^-$) will react further with Me_2NBr :

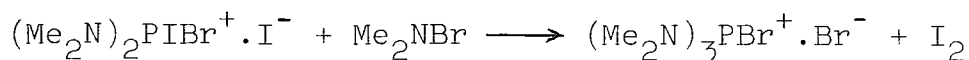

Thus eventually the reaction of excess Me_2NBr with PI_3 produces one kind of phosphonium ion $(\text{Me}_2\text{N})_3\text{PBr}^+$. and this was confirmed by the $^{31}\text{Pnmr}$ spectrum of the fourth reaction as shown in Table 5.5. It was difficult to isolate the various products of the reaction, and it was difficult as well to run Raman spectra because of their very dark blackish colour.

5.18 Results and discussion of the reactions between Me_2NX and PY_3 ($\text{X} = \text{Cl}$ or Br and $\text{Y} = \text{Cl}$, Br or F)

The reaction between dimethyl chloramine and excess phosphorus trichloride was carried out previously in this laboratory (1) and the overall reaction was found to be:

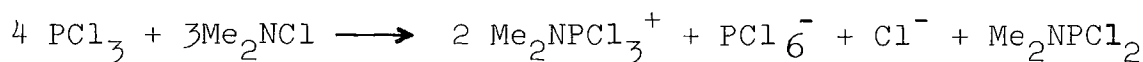

The mechanism suggested for this reaction was (i) initial fast amination of phosphorus trichloride:

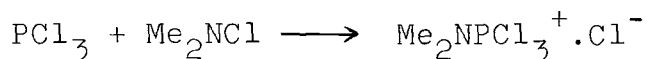

followed by (ii) a slow oxidation of phosphorus trichloride by the phosphonium ion formed in (i). Finally (iii) the tetrachloro phosphonium ion formed would react with chloride ion to generate hexachlorophosphate:

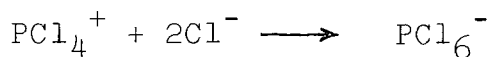

To further test this hypothesis in the present work the reaction was repeated with the chloramine in excess. The reaction was:

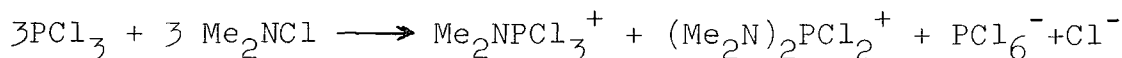

The products of this reaction paralleled those of the one above except that since dimethyl chloramine was in excess it reacted with the phosphine formed in step (ii) to produce phosphonium salt:

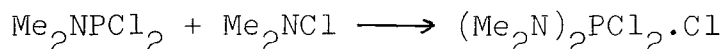

The reaction between solid $\text{Me}_2\text{NPCl}_3 \cdot \text{Cl}$ and PCl_3 was carried out and it was found that no reaction occurred. This result could be attributed to the insolubility of $\text{Me}_2\text{NPCl}_3 \cdot \text{Cl}$ and thus PCl_3 would not be able to react. Nevertheless the reaction could occur in the reaction series discussed above as the salt could react with the PCl_3 as soon as it had been formed in solution.

The reaction between phosphorus tribromide and dimethyl bromamine was a simple amination reaction which could well have occurred by the phosphine attacking the nitrogen of the chloramine in an $\text{S}_{\text{N}}2$ reaction. This reaction did not go any further. This may be due to the fact that PBr_3 does not react with bromine as vigorously as PCl_3 reacts with chlorine, consequently no further reaction would occur between PBr_3 and the phosphonium ion produced. This could also explain why the reaction between PBr_3 and Me_2NCl is a simple amination, but in this case halogen exchange occurred to produce the phosphonium bromide salt. This kind of halogen exchange occurred when Me_2NPBr_2 was reacted with Me_2NCl to produce the phosphonium bromide salt as described in Section 6.18

The reaction between PCl_3 and Me_2NBr was not a simple amination and the products were parallel to those of the reaction between PCl_3 and Me_2NCl :

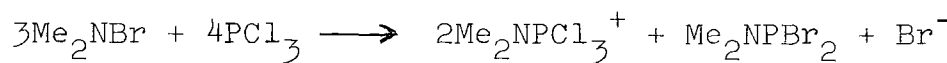

The reaction between dimethyl chloramine and phosphorus trifluoride was a complex one and a mixture of phosphorus species were formed. This may be attributed to the nature of the fluorine atom which is the smallest of the halogen atoms and the most electronegative and facile exchange reactions are known to occur involving phosphorus-fluorine bonds, particularly reactions that generate hexafluorophosphate (71). The initial steps of this reaction could be the halodmination of the phosphorus atom to produce dimethylamine trifluorochloro phosphorane:

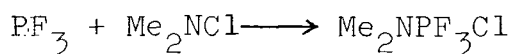

The phosphorane could then rearrange:

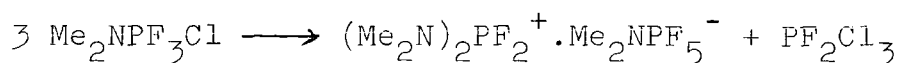

and the PF_2Cl_3 could disproportionate to give hexafluorophosphate.

The reaction between PF_3 and dimethyl bromamine produced a mixture of phosphorus species as shown in Section 5.11.

The suggested reaction pathway for this reaction is represented by the equations:

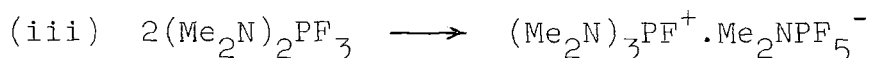
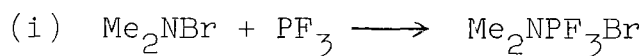

CHAPTER SIX

THE REACTIONS OF HALAMINES WITH
A VARIETY OF ORGANO HALO SUBSTITUTED PHOSPHINES

6.1 Introduction

The reactions which have been carried out between phosphorus trichloride and dimethyl chloramine and the parallel reaction with dimethyl bromamine as described in Chapter Five motivated interest towards a comparative study. Thus the reactions of dimethyl chloramine and dimethyl bromamine with halo substituted phosphine have been studied and reported in this chapter. The reactions of $(\text{Me}_2\text{N})_n\text{PF}_{3-n}$ ($n = 1, 2, 3$) phosphines with the chloramine and the bromamine were performed to throw some light on the reaction of phosphorus trifluoride with dimethyl chloramine and the parallel reaction with dimethyl bromamine. This work has been also directed towards the expansion of the research in this field, since the study of very few reactions have been published in the course of the last thirty years (Section 1.2.1).

6.2 The reaction between dimethyl chloro phosphine and dimethyl chloramine

A reaction vessel (figure 2.2b) containing 3cm^3 of dry degassed petroleum ether was connected to the vacuum line and 6.2 mmol dimethyl chlorophosphine condensed into it. The vessel was allowed to warm to room temperature to let the phosphine dissolve in the petroleum ether and then cooled to -196°C , so that 8.8 mmol of dimethyl chloramine could be condensed onto the solution. After the cell had been kept at -45°C for five hours a white solid was observed. The gas phase spectrum of the most volatile fraction at room temperature showed the presence of dimethyl chloramine and

petroleum ether, which were pumped away. The white solid left inside the cell, when dissolved in dichloro methane, gave a ^{31}P nmr spectrum showing one peak at -1033 p.p.m. as shown in figure 54 indicating the formation of a tetra coordinated cationic phosphorus species. The infrared spectrum is shown in figure 20 and the elemental analysis results are listed in Table 6.1.

Table 6.1

Element	Calculated for $\text{Me}_2\text{NPMe}_2\text{Cl}_2$	Found
C	27.29	27.32
H	6.82	6.49
N	7.96	6.04
P	17.62	17.95
Cl	40.31	40.27

From these results it is likely that simple amination of the phosphine occurred and that the reaction can be written as:

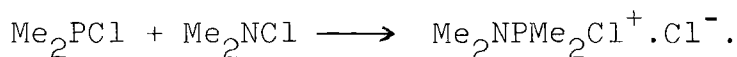

6.3 The reaction between dimethyl chloro phosphine and dimethyl bromamine

Dimethyl bromamine (7.2 mmol) was degassed and condensed onto a solution of 9.1 mmol of dimethyl chloro phosphine dissolved in 4cm^3 of dry degassed petroleum ether inside a reaction vessel (figure 2.2b). After the reactants had been kept at -30°C (the freezer temperature) for eight hours the formation of a white solid was observed. The gas phase infrared spectrum of the most volatile fractions showed a

mixture of dimethyl chloro phosphine and petroleum ether. After pumping off the volatile substances a white solid remained, which when dissolved in dichloromethane, showed one sharp peak at -103.1 p.p.m. in the ^{31}P nmr spectrum. This chemical shift corresponds to the chemical shift for $\text{Me}_2\text{NPMe}_2\text{Cl}^+.\text{Cl}^-$ ($\delta = -103.3$ p.p.m.) (which was described in Section 6.2). It is unlikely to be the $\text{Me}_2\text{NPMe}_2\text{Br}^+$ ion as this would have an upfield chemical shift from the chloro cation. The elemental analysis results are listed in Table 6.2.

Table 6.2

Element	Calculated for $\text{Me}_2\text{NPMe}_2\text{Cl}.\text{Br}$	Found
C	21.28	20.39
H	5.45	6.02
N	6.35	6.55
P	14.07	14.10
Cl	36.26	36.13
Br	16.09	16.03

These results imply that simple amination of the product has occurred and that the reaction can be written as:

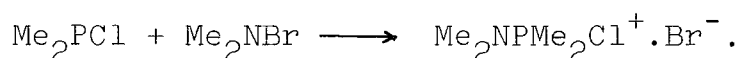

6.4 The reaction between methyl dichloro phosphine and dimethyl chloroamine

This reaction was carried out by condensing 5.7 mmol of dimethyl chloroamine onto 4.9 mmol of methyl dichloro phosphine dissolved in 3cm^3 of dry degassed petroleum ether inside a reaction vessel (figure 2.2b). The reactants were

kept at -83°C for eighteen hours and then allowed to warm to room temperature. The gas phase infrared spectrum of the most volatile fraction showed a mixture of dimethyl chloroamine and petroleum ether. These were pumped away leaving a white solid. The ^{31}P nmr spectrum of this solid dissolved in dichloro methane showed one sharp peak only at -87.1 p.p.m. (figure 55) indicating the presence of a four coordinate phosphonium ion. The infrared spectrum of the product is shown in figure 21 and the elemental analysis results are listed in Table 6.3.

Table 6.3

Element	Calculated for $\text{Me}_2\text{NPMe}_2\text{Cl}_3$	Found
C	18.33	18.09
H	4.58	4.58
N	7.13	7.74
P	15.79	15.81
Cl	54.16	53.75

The above results indicate that simple amination of the phosphine has occurred and the overall reaction is as follows:



6.5 The reaction between methyl dichloro phosphine and dimethyl bromamine

A degassed dry sample of dimethyl bromamine (6.9 mmol) was condensed onto 5.2 mmol of methyl dichloro phosphine dissolved in 2cm^3 of dry degassed petroleum ether inside a reaction vessel (figure 2.2b) at -196°C . The reactants were

kept at -45°C with occasional shaking for an hour. On warming the cell to room temperature, the infrared spectrum of the most volatile fraction showed a mixture of dimethyl bromamine and petroleum ether. A white solid was left in the vessel when the volatile substances were pumped off through the vacuum line. This produce was washed with petroleum ether inside the dry box and the $^{31}\text{Pnmr}$ spectrum run in dichloro methane. This showed one sharp peak only at -74.2 p.p.m. which indicated the formation of a tetra coordinate phosphonium ion. This chemical shift is similar to the chemical shift found for $\text{Me}_2\text{NPMeCl}_2^+.\text{Cl}^-$ ($\delta = -87.1$ p.p.m.) prepared as described in Section 6.4. Thus the product is likely to be $\text{Me}_2\text{NPMeCl}_2^+.\text{Br}^-$. The infrared spectrum of the product is shown in figure 22 and the elemental analysis results are listed in Table 6.4.

Table 6.4

Element	Calculated for $\text{Me}_2\text{NPMeCl}_2.\text{Br}$	Found
C	14.95	14.68
H	3.74	4.01
N	5.81	5.96
P	12.87	12.77
Br	33.18	31.85
Cl	29.44	28.26

These results indicated that the phosphine was aminated by dimethyl bromamine to produce phosphonium salt and the overall reaction could be written as follows:

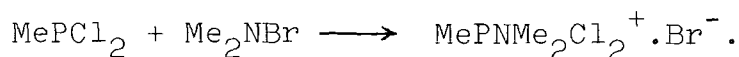

6.6 The reaction between dicyclohexyl chloro phosphine and dimethyl chloroamine

A dry degassed sample of dichloro methane (3cm^3) was distilled onto 6.8 mmol of dicyclohexyl chloro phosphine inside a reaction vessel (figure 2.2b). The tube was allowed to warm to room temperature and was shaken until the phosphine was completely dissolved. After cooling to -196°C a dry degassed sample of dimethyl chloroamine (9.5 mmol) was condensed onto the phosphine solution and the vessel kept at -23°C for five hours. After the tube had warmed to room temperature the infrared gas phase spectrum of the most volatile fraction was taken and showed a mixture of dichloro methane and dimethyl chloroamine. These were pumped away, leaving a white solid. The ^{31}P nmr spectrum of this product dissolved in dichloro methane showed one sharp peak only at -104.7 p.p.m. (figure 56) due to the formation of a tetra coordinate cationic phosphorus species. The infrared spectrum of the product is shown in figure 23 and the elemental analysis results are listed in Table 6.5.

Table 6.5

Element	Calculated for $(\text{C}_6\text{H}_{11})_2\text{PNMe}_2\text{Cl}_2$	Found
C	53.86	53.74
H	8.98	9.21
N	4.49	4.63
P	9.94	9.86
Cl	22.73	22.91

These results show that amination had occurred and that the reaction is as follows:

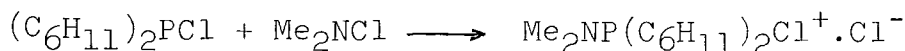

6.7 The reaction between dicyclohexyl chloro phosphine and dimethyl bromamine

Dicyclohexyl chloro phosphine (5.3 mmol) was dissolved in 3cm³ of dry degassed dichloro methane, inside a reaction vessel (figure 2.2b). The vessel was cooled to -196°C, so that 6.8 mmol of dimethyl bromamine could be condensed onto the phosphine solution. The reactants were kept at -45°C for five hours, with shaking from time to time. The vessel was allowed to warm to room temperature and the infrared spectrum of the most volatile substances showed a mixture of dimethyl bromamine and dichloro methane. These were pumped away leaving a white solid. This was washed three times with petroleum ether inside the dry box. The ³¹Pnmr spectrum of the solid dissolved in dichloro methane showed one sharp peak only at -104.3 p.p.m. This shift indicates the formation of a tetra coordinate phosphonium ion, and it is similar to the chemical shift found for Me₂NP(C₆H₁₁)₂Cl⁺.Cl⁻ (δ=104.7 p.p.m.) which had been prepared as described in Section 6.6. This implies that the product is Me₂NP(C₆H₁₁)₂Cl⁺.Br⁻, however if the product was the bromo phosphonium salt the chemical shift would be shifted upfield in comparison with the chemical shift for the chloro salt. The elemental analysis results are listed in Table 6.6.

Table 6.6

Element	Calculated for Me ₂ NP(C ₆ H ₁₁) ₂ ClBr	Found
C	47.14	46.76
H	7.86	7.99
N	3.93	4.10
P	8.70	8.74
Cl	9.95	9.55
Br	22.42	21.75

These results indicate that simple amination has occurred to produce a tetra coordinate phosphonium ion, thus the overall reaction is:

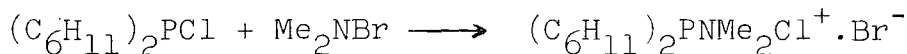

6.8 The reaction between bis(dimethylamino)chloro phosphine and dimethyl bromamine

A dry degassed sample of dimethyl bromamine (5.6 mmol) was distilled into a solution of 4.2 mmol of bis(dimethylamino)chloro phosphine dissolved in 4cm³ of dry degassed petroleum ether inside a reaction vessel (figure 2.2b). The vessel was kept at -45°C for four hours with occasional shaking. A white solid formed. After the cell was allowed to warm to room temperature, the infrared spectrum of the most volatile fraction showed a mixture of petroleum ether and dimethyl bromamine. These volatile substances were pumped away leaving the white solid. The ³¹Pnmr spectrum of this solid dissolved in dichloro methane showed one sharp peak only at -53.3 p.p.m. due to the formation of a tetra coordinate phosphonium ion. The chemical shift of this phosphonium ion is identical to that of (Me₂N)₃PCl⁺.Cl⁻, which has been prepared by reacting (Me₂N)₂PCl with Me₂NCl (1). Moreover, the chemical shift of the bromo phosphonium ion (Me₂N)₃PBr⁺.Br⁻ which has been prepared by the bromination of (Me₂N)₃P (Section 4.10) has a chemical shift of -48.3 p.p.m. This suggests that the phosphonium ion produced is (Me₂N)₃PCl⁺. The chemical analysis results are shown in Table 6.7.

Table 6.7

Element	Calculated for (Me ₂ N) ₃ PClBr	Found
C	15.43	15.28
H	3.86	3.91
N	18.00	18.42
P	13.28	13.17
Br	34.24	33.21
Cl	15.19	14.73

From the above results it appears that simple amination of the phosphine occurred, the overall reaction being:

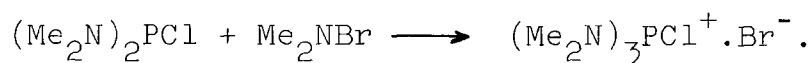

6.9 The reaction between dimethyl amino dichloro phosphine and dimethyl bromamine

A sample of degassed dimethyl bromamine (7.4 mmol) was condensed onto a dry degassed solution of *dimethyl amino dichloro* phosphine (6.5 mmol) in 4cm³ of petroleum ether inside a reaction vessel (figure 2.2b), at -196°C. The vessel was kept at -30°C (the freezer temperature) for seven hours. A white solid formed and the gas phase infrared spectrum of the most volatile fraction showed a mixture of dimethyl bromamine and petroleum ether. When the volatile substances were pumped away the white solid remained. The ³¹Pnmr spectrum of the solid dissolved in dichloro methane showed one sharp peak only at -51.6 p.p.m. due to the formation of (Me₂N)₂PCl₂⁺. This cation (as the chloride salt) has been prepared previously by the reaction between dimethyl chloramine and dimethyl amino dichloro phosphine (1), and gave a

^{31}P nmr chemical shift of -51.6 p.p.m. in dichloro methane. The elemental analysis results are listed in Table 6.8.

Table 6.8

Element	Calculated for (Me ₂ N) ₂ PCl ₂ Br	Found
C	17.79	17.94
H	4.45	4.85
N	10.38	9.81
P	11.49	11.44
Br	29.28	29.02
Cl	26.28	25.75

These results indicate that simple amination of the phosphine has occurred and that the reaction can be represented by the following equation:

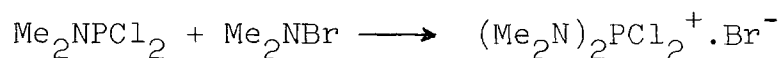

6.10 The reaction between bis(dimethylamino)bromophosphine and dimethyl bromamine

A dry degassed sample of dimethyl bromamine (5.2 mmol) was condensed onto a solution of bis(dimethylamino)bromophosphine (3.3 mmol) dissolved in 3cm³ of dry, degassed petroleum ether, inside a reaction vessel (figure 2.2b) at -196°C. After the vessel had been kept at -30°C (the freezer temperature) for eighteen hours, an orange solid formed, and the vessel was allowed to warm to room temperature. The gas phase infrared spectrum of the most volatile fraction showed a mixture of dimethyl bromamine and petroleum ether. These were pumped away leaving the orange solid. The ^{31}P nmr spectrum of the solid dissolved in dichloro methane showed one sharp

peak only at -48.3 p.p.m. due to the formation of $(\text{Me}_2\text{N})_3\text{PBr}^+\text{Br}^-$ a phosphonium salt, which has been prepared by the bromination of tris(dimethylamino)phosphine, (Section 4.10), and gave a $^{31}\text{Pnmr}$ chemical shift of -48.3 p.p.m. (figure 41). The infrared spectrum of this solid was identical to that of $(\text{Me}_2\text{N})_3\text{PBr}^+\text{Br}^-$ shown in figure 15. The elemental analysis results are listed in Table 6.9.

Table 6.9

Element	Calculated for $(\text{Me}_2\text{N})_3\text{PBr}_2$	Found
C	22.30	22.27
H	5.58	5.69
N	13.01	13.42
P	9.60	9.51
Br	49.50	50.11

These results imply that simple amination of the phosphine has occurred:

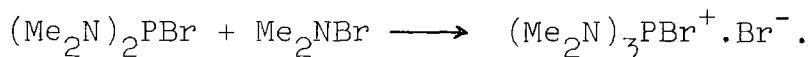

6.11 The reaction between dimethyl amino dibromo phosphine and dimethyl bromamine.

This reaction was carried out by the condensation of dry degassed dimethyl bromamine (5.21 mmol) onto a solution of dimethyl amino dibromo phosphine (4.75 mmol) dissolved in 5cm^3 of dry, degassed petroleum ether inside a reaction vessel (figure 2.2b) at -196°C . The reactants were kept at -45°C for seven hours. After the vessel had been allowed to warm to room temperature the gas phase infrared spectrum of the most volatile fraction showed a mixture of dimethyl bromamine

and petroleum ether. These were pumped away leaving a yellowish-orange solid. The ^{31}P nmr spectrum of this solid showed one broad peak only at -46.3 p.p.m., due to the formation of $(\text{Me}_2\text{N})_2\text{PBr}_2^+.\text{Br}^-$ which has been prepared by the bromination of bis(dimethyl amino) bromo phosphine (Section 4.9) and gave a ^{31}P nmr chemical shift of -46.4 p.p.m. (figure 40). The infrared spectrum of the product is identical to the infrared spectrum of $(\text{Me}_2\text{N})_2\text{PBr}_2^+.\text{Br}^-$ (figure 14) and the elemental analysis results are listed in Table 6.10.

Table 6.10

Element	Calculated for $(\text{Me}_2\text{N})_2\text{PBr}_3$	Found
C	17.22	17.01
H	4.30	4.79
N	10.04	10.53
P	11.12	10.98
Br	57.32	57.05

These results indicate that simple amination occurred on the phosphorus atom:

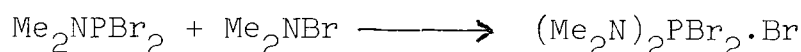

6.12 The preparation of dimethylamino difluoro phosphine

A sample of a dry, degassed dimethylamine was condensed into a calibrated cold finger (figure 2.5) at -196°C , then it was allowed to melt and the volume was measured as 8.3 cm^3 (126 mmol). This was condensed into the cold finger of a three litre bulb. A sample of phosphorus trifluoride (prepared as described in Section 5.9) was condensed into the

calibrated cold finger (figure 2.5) at -196°C . This sample was degassed, allowed to warm to -112.5°C and its volume as a liquid was measured as 1.9cm^3 (84 mmol). The phosphorus trifluoride was condensed onto the amine inside the cold finger of the bulb at -196°C . The reactants were allowed to warm to -112.5°C for twenty minutes and then to -83°C for five hours. A white solid (dimethyl ammonium fluoride) was formed and the volatile contents of the bulb were condensed into a modified ^{31}P nmr tube (figure 2.5) at -196°C . After the tube had been allowed to warm to room temperature a colourless liquid was observed. The gas phase infrared spectrum of this showed the absence of dimethylamine. The ^{31}P nmr spectrum of the liquid showed a triplet centred at -143.5 p.p.m. ($J = 1196.4$ Hz). This corresponds well with the chemical shift reported for dimethylamino difluoro phosphine ($\delta = 143.0$ p.p.m., $J = 1196.0$ cps) (97,98).

6.13 The reaction between dimethylamino difluoro phosphine and dimethyl chloramine

A dry, degassed sample of dimethyl chloramine (6.1 mmol) was distilled onto a dry, degassed sample of dimethylamino difluoro phosphine (4.7 mmol) dissolved in 3cm^3 of dry, degassed dichloromethane inside a modified ^{31}P nmr tube (figure 25) at -196°C . The tube was held at -22°C for 40 minutes with occasional shaking, then it was allowed to warm to room temperature. The gas phase infrared spectrum of the most volatile fraction showed a mixture of dimethyl chloramine and dichloromethane. The ^{31}P nmr spectrum (figure 57) showed three major peak systems:

- (1) A doublet centred at -42.5 p.p.m. ($J = 959.5 \text{ Hz}$) due to $(\text{Me}_2\text{N})_3\text{PF}^+$ phosphonium ion, which has been prepared by reacting bis(dimethylamino)fluoro phosphine with dimethyl chloramine as described in Section 6.15.
- (2) A triplet centred at -22.7 p.p.m. ($J = 1060.3 \text{ Hz}$). This indicates the formation of a tetra coordinate phosphonium ion, in which two fluorine atoms are linked to the phosphorus atom. This phosphonium ion was present among the products of the reaction between dimethyl chloramine and phosphorus trifluoride and it is likely to be $(\text{Me}_2\text{N})_2\text{PF}_2^+$.
- (3) A quartet centred at 154.8 p.p.m. ($J = 944.1 \text{ Hz}$), due to the formation of PCl_3F_3^- (99).

The integration ratios of the peaks forming the doublet, triplet and the quartet are 2:3:1.

The overall reaction can be represented by the following equation:

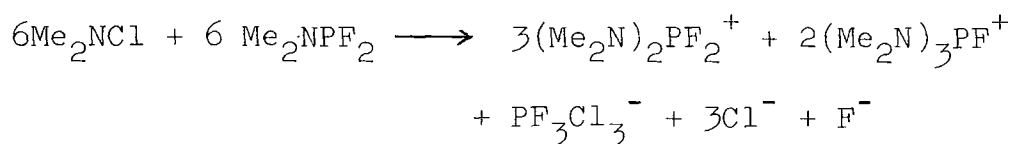

6.14 The preparation of bis(dimethylamino)fluoro phosphine

This preparation was first attempted by the reaction of a stoichiometric quantity of dimethylamine with phosphorus trifluoride in a sealed tube as described by Fleming and Parry (100), but even when the reaction was warmed to 25°C for two weeks incomplete amination occurred and the major product was found to be dimethylamino difluoro phosphine.

Thus dimethylamino difluoro phosphine was first prepared as described in Section 6.12 and this product reacted with a slight excess of dimethylamine.

Dimethylamine (50 mmol) and dimethylamino difluoro phosphine (20mmol) were condensed into a silica tube which was sealed and warmed to -60°C . After three weeks the sealed tube was allowed to reach room temperature and the formation of a considerable amount of white solid was noticed (dimethylammoniumfluoride). The ampoule was fitted to an ampoule breaker (figure 2.3) and attached to the fractionation section of the vacuum line (figure 1). The tube contents were fractionated through a train of cold traps at -23°C , -96°C and -196°C . No liquid condensed at -23°C , and a small amount was trapped at -196°C . The major product condensed at -96°C and showed two products in the ^{31}P nmr spectrum; a doublet centred at -153.5 p.p.m. ($J = 1050$ cps) (101) due to the formation of $(\text{Me}_2\text{N})_2\text{PF}$ and a singlet at -122.5 p.p.m. due to the formation of $(\text{Me}_2\text{N})_3\text{P}$. It was found difficult to separate the two phosphines by using the apparatus available in this laboratory. The gas phase infrared spectrum of the fraction trapped at -196°C showed that it was dimethylamine.

6.15 The reaction between bis(dimethylamino)fluoro phosphine and dimethyl chloramine.

A sample of degassed dimethyl chloramine (3.5 mmol) was condensed onto a degassed solution of 2.8 mmol of bis(dimethylamino)fluoro phosphine (prepared as described in Section 6.14) and dissolved in 2cm^3 of dry, degassed petroleum ether inside

a modified ^{31}P nmr tube (figure 2.5) at -196°C . After the tube had been kept at -23°C for half an hour it was allowed to warm to room temperature. The gas phase infrared spectrum of the most volatile fraction showed the presence of dimethyl chloramine and petroleum ether. These were pumped away leaving a white solid. The ^{31}P nmr spectrum of this solid (figure 26) dissolved in dichloro methane showed the following signals:

1. A singlet at -53.3 p.p.m. This chemical shift is identical to that of $(\text{Me}_2\text{N})_3\text{PCl}^+\text{Cl}^-$ which was produced by reacting Me_2NCl with $(\text{Me}_2\text{N})_3\text{P}$ (1). The phosphonium salt $(\text{Me}_2\text{N})_3\text{PCl}^+\text{Cl}^-$ could be formed by a side reaction between Me_2NCl and the $(\text{Me}_2\text{N})_3\text{P}$ impurity.
2. A doublet centred at -42.6 p.p.m. ($J=1017.8$ Hz) due to the formation of a tetra coordinate phosphorus species, which is likely to be $(\text{Me}_2\text{N})_3\text{PF}^+$.

6.16 The reaction between bis(dimethylamino)fluoro phosphine and dimethyl bromamine

This reaction was carried out by applying the same technique employed in Section 5.14. The amount of the reactants were 2.15 mmol of bis(dimethylamino)fluoro phosphine and 3.01 mmol of dimethyl bromamine. petroleum ether (2cm^3) being used as a solvent. The tube was kept at -45°C for half an hour before it was allowed to warm to room temperature. The gas phase infrared spectrum of the most volatile fraction showed a mixture of dimethyl bromamine and petroleum ether. These were pumped away leaving a creamish-yellow solid. The

^{31}P nmr spectrum of this solid dissolved in dichloro methane (figure 27) showed two sets of peaks:

1. A singlet at -48.3 p.p.m., this chemical shift is identical to the chemical shift of $(\text{Me}_2\text{N})_3\text{PBr}^+.\text{Br}^-$ which was produced by reacting $(\text{Me}_2\text{N})_3\text{P}$ and Me_2NBr as described in Section 4.10. This is therefore likely to have been produced from the impurity $\text{P}(\text{NMe}_2)_3$.
2. A doublet centred at - 42 p.p.m. ($\tau = 937.6$) due to the formation of a tetra coordinate phosphorus species. Since this doublet appeared also in the ^{31}P nmr spectrum of the reaction between Me_2NCl and $(\text{Me}_2\text{N})_2\text{PF}$ as well, then it is likely to be due to the formation of $(\text{Me}_2\text{N})_3\text{PF}^+.\text{X}^-$ ($\text{X} = \text{Cl}$ or Br).

Thus the reaction between Me_2NX and $(\text{Me}_2\text{N})_2\text{PF}$ is a simple amination:

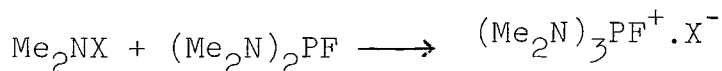

6.17 The reaction of dimethylamino difluoro phosphine with dimethyl bromamine

This reaction has been carried out by employing the same technique described for the reaction between dimethyl amino difluoro phosphine and the chloramines in Section 6.13. The amount of the bromamine used in this reaction was 7.4 mmol and the amount of the phosphine used was 5.1 mmol with dichloro methane as a solvent. The gas phase infrared spectrum of the most volatile fraction showed a mixture of dichloro methane and dimethyl bromamine. The colour of the solution was dark brown and its ^{31}P nmr spectrum (figure 28) showed:

1. A doublet centred at -41.1 p.p.m. ($J = 969.2 \text{ Hz}$) which indicates the formation of a tetra coordinate phosphonium ion with one fluorine atom linked to the phosphorus. The chemical shift and the coupling constant of this compound are very close to those of $(\text{Me}_2\text{N})_3\text{PF}^+$, which has been prepared by reacting $(\text{Me}_2\text{N})_2\text{PF}$ with Me_2NX ($X = \text{Cl}$ or Br) as described in Sections 6.15 and 6.16.
2. A quartet centred at 64.5 p.p.m. ($J = 796.7 \text{ Hz}$) due to the formation of $(\text{Me}_2\text{N})_2\text{PF}_3$ ($\delta = 64.5 \text{ p.p.m.}$, $J = 758 \text{ Hz}$) (102).
The integration ratio of the doublet to the quartet was 1:2.5.

From the above result it is possible to represent this reaction by the following equation:

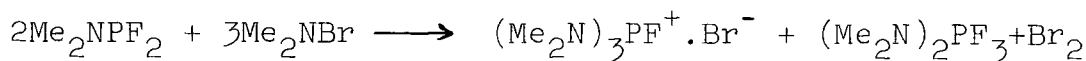

This reaction will be discussed in detail in Section 6.19

6.18 The reaction between dimethylamino dibromo phosphine and dimethyl chloramine

A sample of dimethylamino dibromo phosphine (4.2 mmol) prepared as described in Section 4.7 was dissolved in 4 cm³ of degassed petroleum ether inside a reaction vessel (Fig.2.2b). Dimethyl chloramine (6.8 mmol) was condensed onto the solution at -198°C. The vessel was kept at -45.6°C for seven hours with occasional shaking and was then allowed to warm to room temperature. The gas phase infrared spectrum of the most

volatile fraction showed a mixture of dimethyl chloramine and petroleum ether. These were pumped away leaving an orange solid. The ^{31}P nmr spectrum of the product dissolved in dichloromethane showed one sharp peak at -50.0 p.p.m. (Figure 29). Elemental analysis agreed with the theoretical results for $(\text{Me}_2\text{N})_2\text{PClBr}_2$ as shown in Table 6.11.

Table 6.11

Element	Calculated for $(\text{Me}_2\text{N})_2\text{PClBr}_2$	Found
C	15.27	14.76
H	3.82	4.35
N	8.91	8.99
P	9.86	9.73
Cl	11.31	11.14
Br	50.85	49.90

The nmr spectrum of the product indicated the formation of a tetra coordinate phosphonium ion, which would be generated by simple amination on the phosphorus atom. The nmr spectrum also indicated that the cation formed by this reaction is the chlorobromo species and not the dibromo as this cation has been prepared as its bromide salt (Section 4.9) and has a ^{31}P nmr chemical shift of -46.7 p.p.m.

A possible course for this reaction is:

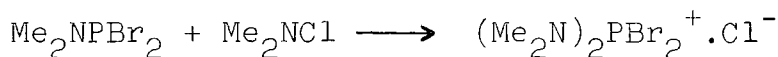

followed by halogen exchange:

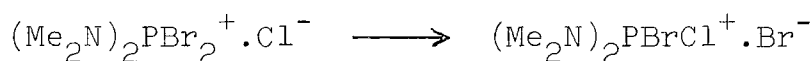

This is to be expected as the phosphorus chlorine single bond energy term is some 63 kJ mol^{-1} stronger than the phosphorus bromine bond energy term (125).

6.19 Results and Discussion

In the work described in this Chapter it was found that the reactions of Me_2NX ($\text{X} = \text{Cl}$ or Br) with chloro or bromo substituted phosphorus were simple aminations. These reactions probably occurred by an $\text{S}_{\text{N}}2$ attack by the phosphorus atom on the nitrogen atom of the halo amine with loss of halide ion from the nitrogen.

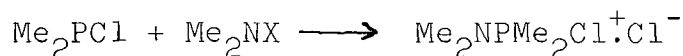

In contrast the reactions in which fluoro substituted phosphine occur were much more complex. The stoichiometry of the reaction between dimethylchloro amine and dimethylaminodifluoro phosphite can be written:

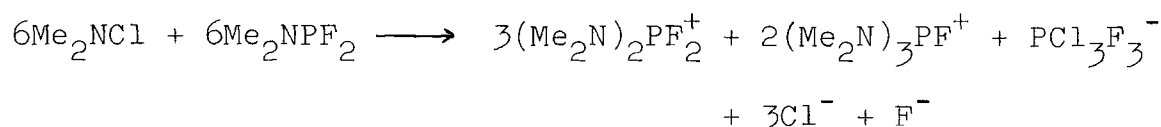

The first step in this reaction could be amination at the phosphorus:

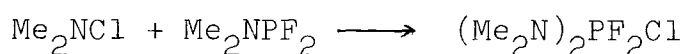

followed by rearrangement of the groups on the phosphorus V species:

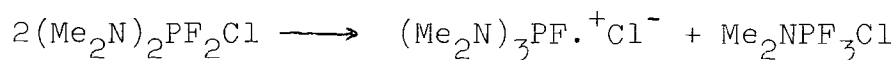

This type of rearrangement is well known in phosphorus V chemistry particularly in the presence of fluorine, e.g.:

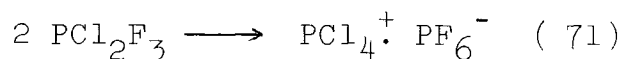

Similarly two molecules of $\text{Me}_2\text{NPF}_3\text{Cl}$ could further rearrange

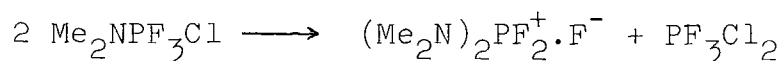

and the PF_3Cl_2 formed could react with chloride ion formed in the first reaction to give the octahedral anion:

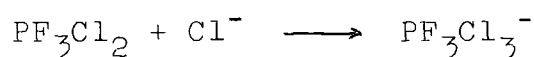

The reaction between dimethyl bromamine and dimethylamino difluoro phosphine was also found to be complex and the stoichiometry can be represented as:

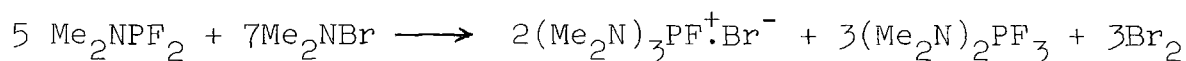

Here again one can envisage initial amination on the phosphorus followed by rearrangement of the phosphorus V species:

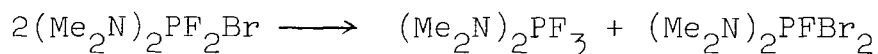
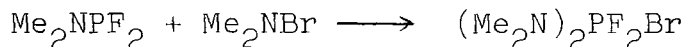

The dibromo species so formed could then be in equilibrium with the phosphine and bromine, similar to the equilibrium that exist between PBr_5 and PBr_3 :

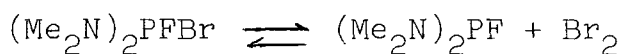

The phosphine would then react with the excess bromamine, as described in section 6.

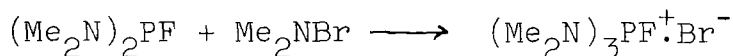

The formation of the bromine was shown by the presence of a brownish liquid.

The reactions between $(\text{Me}_2\text{N})_2\text{PF}$ and Me_2NX ($\text{X} = \text{Cl}$ or Br) produced a tetra coordinate phosphonium salt by simple amination on the phosphorus atom:

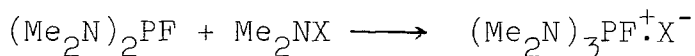

The spectra of these reactions showed a singlet due to the product of the side reaction between $(\text{Me}_2\text{N})_3\text{P}$ (which was found on an impurity with the starting material and Me_2NX). The phosphorus compound produced when $(\text{Me}_2\text{N})_3\text{P}$ was reacted with Me_2NCl was $(\text{Me}_2\text{N})_3\text{PCl}_2$ (1) and that of the parallel reaction with Me_2NBr was $(\text{Me}_2\text{N})_3\text{PBr}_2$ as described in section 7.16.

From the above discussion it is possible to conclude that the reactions of the chloro or the bromo substituted organic phosphine with Me_2NX produced tetra coordinate phosphonium ions by simple amination. The reaction of Me_2NPF_2 with Me_2NX were not simple amination reactions, this could be attributed to the nature of the fluorine atoms, which made it possible for the initially formed phosphorus species to rearrange and to produce both ionic and covalent compounds.

CHAPTER SEVEN

THE REACTIONS OF HALAMINES WITH
A VARIETY OF TRI(ORGANO)PHOSPHINES

7.1 Introduction

The reactions of tris(dimethylamino)phosphine and dimethyl bromamine described in this chapter were carried out in order to compare the results obtained with that of the parallel reaction with dimethyl chloramine (1), which has been found to be:

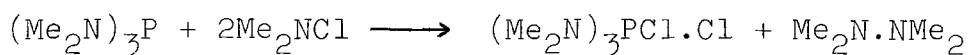

It was thought that the chloramine had failed to aminate tris(dimethylamino)phosphine because of the steric hindrance caused by the three dimethylamino groups linked to the phosphorus atom. Because of this the reactions of Me_2NX ($\text{X} = \text{Cl}$ or Br) with tri(organo)phosphines (with bulky organic groups) were attempted such as the reaction between triphenyl phosphine and dimethyl chloramine, in order to determine whether other bulky groups cause parallel reactions.

7.2 The reaction between dimethyl chloramine and triphenyl phosphine

A sample of triphenyl phosphine (6.2 mmol), purchased from BDH chemicals Ltd. and recrystallised from dichloro methane, was dissolved in 3 cm^3 of dry degassed dichloro methane inside a reaction vessel (Figure 2.2b). Dimethylamine (8.1 mmol) was condensed onto the solution at -196°C . After the reactants had been held at -23°C for three hours, the vessel was allowed to warm to room temperature and the gas phase infrared spectrum of the most volatile fraction was run. This identified a mixture of dimethyl chloramine and dichloro methane. These were pumped away leaving a white

solid, the ^{31}P nmr spectrum of which (Figure 62) showed one peak only at -46.8 p.p.m. This chemical shift indicated the formation of a new tetra coordinate phosphonium ion. The infrared spectrum of the product is shown in Figure 24 and the elemental analyses are listed below (Table 7.1).

Table 7.1

Element	Calculated for $\text{Ph}_3\text{PNMe}_2\text{Cl}$	Found
C	70.29	69.72
H	6.15	7.05
N	4.10	4.38
P	9.08	9.12
Cl	10.38	10.50

These results indicated that simple amination had occurred on the phosphorus atom and the overall reaction can be represented as:

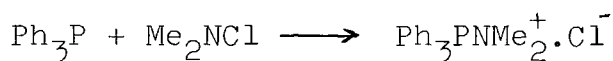

7.3 The reaction between $\text{Ph}_3\text{PNMe}_2\text{Cl}$ and boron trichloride

A sample of $\text{Ph}_3\text{PNMe}_2\text{Cl}$ (5.7 mmol), prepared as described in Section 7.2, was introduced into a reaction vessel (Figure 2.2b). Boron trichloride (7.9 mmol) was condensed onto the phosphonium salt and cooled to -196°C . The vessel was kept at -96°C for half an hour and then connected to the vacuum line. The gas phase infrared spectrum of the most volatile fraction showed only the presence of boron trichloride which was pumped away, leaving a creamish-white solid. The infrared spectrum of this solid (Figure 25) showed the characteristic broad band in the range $650\text{-}750\text{ cm}^{-1}$ due to the formation

of BCl_4^- (103). The ^{31}P nmr spectrum of the solid showed one peak only at -48.8 p.p.m. This chemical shift is very close to that of $\text{Ph}_3\text{PNMe}_2^+\text{Cl}^-$ reported in Section 7.2. The elemental analyses are listed in Table 7.2.

Table 7.2

Element	Calculated for $\text{Ph}_3\text{PNMe}_2^+\text{BCl}_4^-$	Found
C	52.33	51.82
H	4.58	5.07
N	3.05	3.41
P	6.76	6.55
Cl	30.92	31.22

These results confirmed that $\text{Ph}_3\text{PNMe}_2\text{Cl}$ is an ionic compound and the reaction with boron trichloride was:

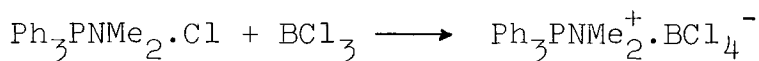

Attempted
7.4 \uparrow hydrolysis of $\text{Ph}_3\text{PNMe}_2\text{Cl}$

A sample of $\text{Ph}_3\text{PNMe}_2\text{Cl}$ (2.1 mmol) prepared as described in Section 7.2 was dissolved in 2.5 cm^3 of distilled water, producing a colourless solution. The ^{31}P nmr spectrum of this solution showed one sharp peak only at -46.4 p.p.m. This chemical shift is very close to that reported for $\text{Ph}_3\text{PNMe}_2\text{Cl}$ in Section 7.2. This result showed that the nitrogen phosphorus bond in this compound is not susceptible to cleavage by water.

7.5 ¹ Attempted reaction between dimethyl bromamine and triphenyl phosphine.

Triphenyl phosphine (5.1 mmol) was dissolved in 4cm³ of dry degassed dichloro methane inside a reaction vessel (Figure 2.2b). Dimethyl bromamine (6.8 mmol) was condensed onto the solution at -196°C. After having been kept at -46.7°C (chlorobenzene cooled bath) for an hour, the vessel was allowed to warm to room temperature and the gas phase infrared spectrum of the most volatile fraction run showing a mixture of dichloromethane and dimethyl bromamine. These were pumped away leaving a pale yellow solid, the infrared spectrum of which is shown in Figure 2b. The ³¹Pnmr spectrum of the solid dissolved in dichloro methane gave one sharp peak at -46.8 p.p.m. This chemical shift is identical to that found for Me₂NPPh₃⁺.Cl⁻ prepared by reacting Me₂NCl with Ph₃P as described in Section 7.2. The elemental analysis are shown in Table 7.3.

Table 7.3

Element	Calculated for Me ₂ NPPh ₃ .Br	Found
C	62.19	61.57
H	5.44	5.83
N	3.63	3.74
P	8.03	8.12
Br	20.71	20.50

These results indicate that the overall reaction is:

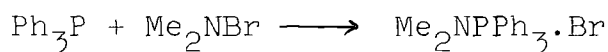

7.6 The reaction between $\text{Me}_2\text{NPPh}_3\text{Br}$ and boron tribromide

A sample of $\text{Me}_2\text{NPPh}_3\text{Br}$ (1.3 mmol) prepared as described in the previous section was introduced into a reaction vessel (Figure 2.2b), and boron tribromide (5cm^3) condensed onto it at -196°C . The reactants were kept at -23.2°C for half an hour, and then allowed to warm to room temperature. The gas phase infrared spectrum showed the presence of boron tribromide only, which was pumped away leaving a pale yellow solid. The infrared spectrum of the solid showed the characteristic peak due to BBr_4^- in the range between 650 cm^{-1} and 760 cm^{-1} . The ^{31}P nmr spectrum of the solid (dissolved in dichloromethane) showed one sharp peak at -46.8 p.p.m. This chemical shift is identical to the chemical shift found for $\text{Me}_2\text{NPPh}_3\cdot\text{Cl}$ prepared by reacting Me_2NCl with Ph_3P as described in Section 7.2. The elemental analyses are listed in Table 7.5.

Table 7.5

Element	Calculated for $\text{Me}_2\text{NPPh}_3\cdot\text{BBr}_4$	Found
C	37.71	36.98
H	3.3	3.88
N	2.2	3.01
P	4.87	4.62
Br	50.22	49.92

These results confirmed the ionic character of $\text{Me}_2\text{NPPh}_3\cdot\text{Br}$ and showed that the reaction with boron tribromide was:

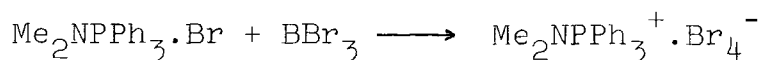

7.7 The hydrolysis of $\text{Me}_2\text{NPPh}_3\text{Br}$

A sample of $\text{Me}_2\text{NPPh}_3\text{Br}$ (1.6 mmol) was introduced into a modified nmr tube (Figure 2.5). When distilled water (3cm^3) was added to the phosphorane, a pale yellow liquid was formed. The ^{31}P nmr spectrum of this liquid showed one sharp peak only at -46.8 p.p.m. which was identical to the chemical shift found for $\text{Me}_2\text{NPPh}_3\text{Br}$. Thus it is possible to conclude that water cleaved neither the N-P nor the C-P bonds.

7.8 The reaction between tri(n-butyl) phosphine and dimethylchloramine

A sample of tri(n-butyl)phosphine (3.1 mmol) obtained from BDH Chemicals Ltd., and used without further purification was dissolved in 4cm^3 of dry degassed petroleum ether inside the reaction vessel (Figure 2.2b). Dimethyl chloramine (4.6 mmol) was condensed onto the solution at -196°C . After the reactants had been kept at -23.2°C (carbon tetrachloride cold bath) for three hours, they were allowed to warm to room temperature and the gas phase infrared spectrum of the most volatile fraction was run showing a mixture of petroleum ether and dimethyl chloramine. These were pumped away leaving a white solid which was washed three times with petroleum ether inside the drybox. The infrared spectrum of the product is shown in Figure 27. The ^{31}P nmr spectrum of the product dissolved in dichloro methane showed one sharp peak at -67.8 p.p.m. The elemental analyses are listed in Table 7.6.

Table 7.6

Element	Calculated for (C ₄ H ₉) ₃ PNMe ₂ .Cl	Found
C	59.69	59.53
H	11.73	12.15
N	4.97	5.01
P	11.01	11.23
Cl	12.60	12.49

These results show that simple amination had occurred at the phosphorus and that the overall reaction was:

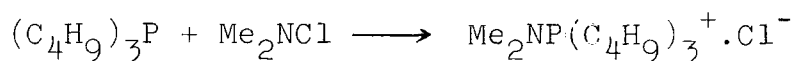

7.9 The reaction between tri(n-butyl)phosphine and dimethyl bromamine

Tri(n-butyl) phosphine (2.8 mmol) was dissolved in 4cm³ of dry degassed petroleum ether inside a reaction vessel (Figure 2.2b). Dimethyl bromamine (5.2 mmol) was condensed onto the solution at -196°C. The reactants were held at -30°C (the freezer temperature) for five hours and then allowed to warm to room temperature. The gas phase infrared spectrum of the most volatile fraction showed a mixture of petroleum ether and dimethylbromamine. These were pumped away leaving a yellow solid which was washed three times with petroleum ether inside the drybox. The infrared spectrum of the product was very similar to that of Me₂NP(C₄H₉)₃.Cl. The ³¹Pnmr spectrum of the solid dissolved in dichloro methane showed one sharp peak only at -66.2 p.p.m. This chemical shift is very close to the chemical shift found for Me₂NP(C₄H₉)₃⁺.Cl⁻

which was prepared as described in Section 7.8. The elemental analyses are listed in Table 7.7.

Table 7.7

Element	Calculated for (C ₄ H ₉) ₃ PNMe ₂ Br	Found
C	51.55	51.33
H	10.13	10.51
N	4.30	4.79
P	9.51	9.38
Br	24.52	24.20

These results indicate that simple amination occurred at the phosphorus atom of (C₄H₉)₃P and that the overall reaction was:

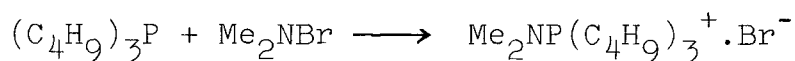

7.10 The hydrolysis of (C₄H₉)₃PNMe₂Cl and (C₄H₉)₃PNMe₂·Br

Two samples, one of the (C₄H₉)₃PNMe₂Cl salt and the other of the (C₄H₉)₃PNMe₂Br salt were introduced into two ³¹Pnmr tubes. Then they were exposed to wet nitrogen for three hours. The spectrum of each sample dissolved in dichloro methane showed two sharp peaks, one due to the unhydrolysed phosphonium salt and a second peak at -43.5 p.p.m. due to the form of the known phosphine (C₄H₉)₃PO oxide (104). This indicates that both phosphonium salts were slowly hydrolysed by water as follows:

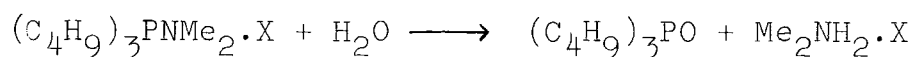

7.11 The reaction between trimethyl phosphine and dimethyl chloramine

A sample of trimethyl phosphine (3.1 mmol) obtained from Fluorochemicals Limited and purified by vacuum fractionation was distilled into a reaction vessel (Figure 2.2b) and degassed petroleum ether (3cm³) was condensed onto the phosphine at -196°C. The vessel was allowed to warm to room temperature and shaken to dissolve the trimethyl phosphine into the ether. Dimethyl chloramine (5.7 mmol) was condensed onto the solution at -196°C and the reactants were kept at -83°C (dry ice-acetone mixture) for five hours. After this time the vessel was allowed to warm to room temperature and the gas phase infrared spectrum of the most volatile fraction showed a mixture of dimethyl chloramine and petroleum ether. These were pumped away leaving a white solid which was washed three times with petroleum ether inside the drybox. The infrared spectrum of the product is shown in Figure 28. The ³¹Pnmr spectrum of the solid product showed a broad peak at -74.2 p.p.m. and the elemental analyses are listed in Table 7.8.

Table 7.8

Element	Calculated for Me ₃ PNMe ₂ .Cl	Found
C	38.60	38.44
H	9.65	10.06
N	9.0	9.34
P	19.94	19.72
Cl	22.81	22.80

These results indicate that simple amination occurred at the phosphorus atom of Me_3P . This reaction can be represented by the following equation:



7.12 The reaction between trimethyl phosphine and dimethyl bromamine

Trimethyl phosphine (3.5 mmol) was distilled into a reaction vessel (Figure 2.2b) at -196°C . A dry degassed sample of petroleum ether (5cm^3) was condensed onto the phosphine at -196°C and the vessel allowed to warm to room temperature so that after shaking the trimethyl phosphine would dissolve in the petroleum ether. A sample of dry degassed dimethyl bromamine (4.9 mmol) was condensed onto this solution and the reactants kept at -46.7°C (chlorobenzene cold bath) for four hours. The vessel was then allowed to warm to room temperature and the gas phase infrared spectrum of the most volatile fraction run which showed a mixture of petroleum ether and dimethyl bromamine. These were pumped off leaving a yellow solid which was washed three times with petroleum ether inside the drybox. The infrared spectrum of the product is very similar to that of $\text{Me}_3\text{PNMe}_2\cdot\text{Cl}$. The ^{31}P nmr spectrum of the solid showed one broad peak at -75.8 p.p.m. The elemental analyses are listed in Table 7.9.

Table 7.9

Element	Calculated for $\text{Me}_2\text{NPMe}_3\cdot\text{Br}$	Found
C	30.02	29.79
H	7.50	7.83
N	7.00	7.21
P	15.51	15.43
Br	39.97	39.86

These results indicate that simple amination occurred at the phosphorus of the trimethyl phosphine to produce a four coordinate phosphonium salt. The overall reaction was as follows:

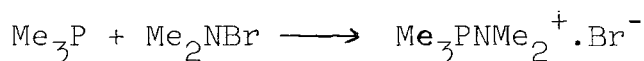

7.13 The hydrolysis of $\text{Me}_3\text{PNMe}_2 \cdot \text{X}$ (X = Cl or Br)

Samples of the two phosphonium salts were introduced into two Pnmr tubes and exposed to wet nitrogen for three hours. These samples were each dissolved in 1.5cm^3 of dichloro methane and the $^{31}\text{Pnmr}$ spectra showed two sharp peaks in each case, one at -76.4 p.p.m. (due to unhydrolysed $\text{Me}_3\text{PNMe}_2 \cdot \text{X}$) and the other peak at -50.1 p.p.m. (due to the formation of $\text{Me}_3\text{P=O}$). This result implies that water cleaved the P-N bond of phosphonium salts and that the hydrolysis can be represented by the following equation:

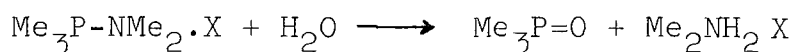

7.14 The reaction between tri(cyclohexyl)phosphine and dimethylchloramine

Tri(cyclohexyl)phosphine (2.6 mmol) obtained from Floro Chemicals Limited and recrystallised from dichloro methane was dissolved in 4cm^3 of dry degassed dichloromethane inside the reaction vessel (Figure 2.2b). Dimethyl chloramine (3.8 mmol) was degassed and condensed onto the solution at -196°C and the reactants were warmed to -23.2°C (carbon tetra chloride cold bath) for an hour. After this time the vessel

was allowed to warm to room temperature and the gas phase infrared spectrum run, which showed a mixture of dichloro methane and dimethyl chloramine. These were pumped away leaving a white solid. The solid started to liquify and after five minutes had the appearance of a gel. The ^{31}P nmr spectrum of this substance showed six peaks at -90.1 p.p.m., -82.5 p.p.m., -65.1 p.p.m., -32.7 p.p.m., -18.4 p.p.m. and at 9.2 p.p.m.

This reaction was repeated with some modification. Tri(cyclohexyl)phosphine (1.5 mmol) was dissolved in 2cm³ of dry degassed dichloro methane inside a modified ^{31}P nmr (Figure 2.5). Dimethyl chloramine (2.9 mmol) was degassed and condensed onto the solution at -196°C. The tube was kept at -83°C (dry ice-acetone mixture) for two hours and then cooled to -196°C and fitted into the probe of the ^{31}P nmr spectrometer for a short run. The spectrum showed one sharp peak at -94.6 p.p.m. but when the tube was allowed to warm to room temperature for about five minutes the spectrum contained six peaks (as reported in the first experiment).

This result implies that the reaction initially produced a phosphonium salt which has the chemical shift of -94.6 p.p.m. and it is likely to be the product of simple amination:

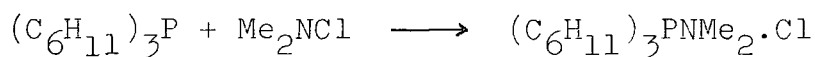

Then this phosphonium salt decomposed to produce a mixture of phosphorus compounds.

7.15 The preparation of tris(dimethylamino)phosphine

This phosphine was prepared as described by A. Michaelis (105) using the reaction:

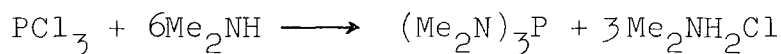

Two modifications were made to improve the yield of the reaction. The first was that the addition of the amine solution to the phosphine solution was carried out at -83°C so as to get more efficient cooling than that obtained by using crushed ice. This was important so as to control the exothermic reaction and to stop any loss of the amine by evaporation. The second modification was to leave the reaction mixture overnight at room temperature to give more time for the reaction to be completed.

The purity of the product was determined by ^{31}P nmr spectroscopy and elemental analysis (see Table 7.10 below). The spectrum showed one sharp peak only at -122.6 p.p.m. due to the formation of $(\text{Me}_2\text{N})_3\text{P}$ (reported value -123 p.p.m. (53)).

Table 7.10

Element	Calculated for $\text{C}_6\text{H}_{18}\text{N}_3\text{P}$	Found
C	44.17	44.11
H	11.04	11.47
N	25.77	25.89
P	19.02	19.00

7.16 The reaction between tris(dimethylamine)phosphine and dimethylbromamine

Dimethylbromamine (5.1 mmol) was degassed, distilled through the vacuum line (Figure 2.1), and condensed onto a degassed sample of tris(dimethylamino)phosphine (3.7 mmol) dissolved in 3ml of dry degassed petroleum ether into a reaction vessel (Figure 2.2b) at -196°C . The reactants were kept at -23.2°C (carbon tetrachloride cold bath) for four hours and then allowed to warm to room temperature. The gas phase infrared spectrum of the most volatile fractions showed a mixture of dimethyl bromamine, petroleum ether and a substance which could have been tetramethyl hydrazine. These were pumped away leaving a yellowish-orange solid. This was washed three times with petroleum ether inside the drybox and dried *in vacuo*. The infrared spectrum of this solid was identical to the infrared spectrum of $(\text{Me}_2\text{N})_3\text{PBr}^+\cdot\text{Br}^-$ (Figure 15) which has been prepared by the bromination of tris(dimethylamino)phosphine as shown in Section 4.10 . The ^{31}P nmr spectrum showed one broad peak at -48.3 p.p.m. which was identical to the chemical shift found for $(\text{Me}_2\text{N})_3\text{PBr}^+\cdot\text{Br}^-$ (Figure 41). The elemental analyses are listed in Table 7.11

Table 7.11

Element	Calculated for $(\text{Me}_2\text{N})_3\text{PBr}_2$	Found
C	22.30	21.73
H	5.58	5.96
N	13.01	13.41
P	9.60	9.54
Br	49.50	49.27

These results indicate that this reaction produced $(\text{Me}_2\text{N})_3\text{PBr}^+\cdot\text{Br}^-$ and a volatile substance which could be tetramethyl hydrazine. This reaction was carried out with modifications so as to prove the presence of tetramethyl hydrazine. A dry degassed sample of dimethylbromamine (4.9 mmol) was condensed onto a degassed sample of tris(dimethylamino)phosphine (5.3 mmol) inside a reaction vessel (Figure 2.2b) at -196°C . The reactants were held at -83°C (dry ice-acetone mixture) for eight hours, with occasional shaking. When the vessel was allowed to warm to room temperature, a yellowish-orange solid was apparent. The gas phase infrared spectrum of the most volatile fractions showed tetramethyl hydrazine only, which was pumped away. The ^{31}P nmr spectrum of the product showed two peaks, a sharp one at -122.5 p.p.m. due to tris(dimethylamino)phosphine (53) and a broad peak at -48.3 p.p.m. due to the formation of $(\text{Me}_2\text{N})_3\text{PBr}^+\cdot\text{Br}^-$. The product was washed five times with petroleum ether inside the drybox to remove tris(dimethylamino) phosphine and the yellowish-orange solid was dried under vacuum. Its infrared spectrum was identical to $(\text{Me}_2\text{N})_3\text{PBr}^+\cdot\text{Br}^-$ from the first preparation. The elemental analyses are listed in Table 7.12.

Table 7.12

Element	Calculated for $(\text{Me}_2\text{N})_3\text{PBr}_2$	Found
C	22.30	21.90
H	5.58	6.25
N	13.01	13.29
P	9.60	9.48
Br	49.50	49.38

These results indicate that the overall reaction was as follows:

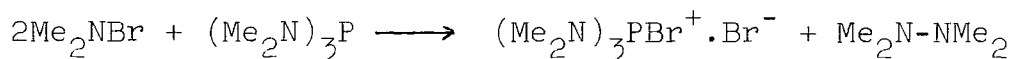

7.17 Results and Discussion

It is possible to conclude from the results of the reactions described in this chapter that in most cases simple amination occurred on the phosphorus atom to produce phosphonium salts in a nucleophilic substitution reaction, e.g.:

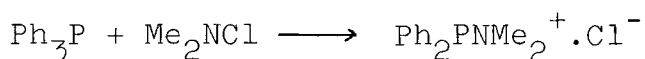

Simple amination did not take place on the phosphorus atom of tris(dimethylamino)phosphine when it was reacted with dimethyl bromamine, instead bromination of the phosphine occurred. This result parallels that found by H.H. Sisler when he reacted dimethyl chloramine with tris(dimethylamino) phosphine (4) and the same result found by Khabbass (1) when the chlorophosphorane and tetramethyl hydrazine were isolated.

This result could be explained by the steric hindrance caused by the three dimethyl amino groups linked to the phosphorus. This would make it difficult for the phosphorus atom to attack the nitrogen of the bromamine to produce $(\text{Me}_2\text{N})_4\text{P}^+$. The alternative site of attack by phosphorus is the bromine atom:

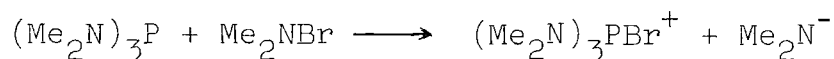

It is unlikely that the dimethylamide ion could have any real existence in the system, but it would attack a second bromamine molecule in a concerted reaction:

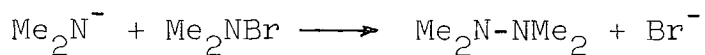

The result of this reaction is parallel to that of the reaction between triphenyl phosphite and phenyl sulphenyl chloride (61,62).



although triphenyl phosphite reacts with halamines to give amination products (Section 7.2,7.5).

The reaction between tricyclohexyl phosphine and dimethyl chloramine initially produced phosphonium salts as implied by the ^{31}P nmr spectrum, but this salt seemed to rearrange to produce a mixture of unknown species, as was shown by the ^{31}P nmr spectrum when the product was allowed to warm to room temperature.

CHAPTER EIGHT

THE REACTIONS OF HALAMINES WITH
A VARIETY OF ORGANO PHOSPHINES

8.1 Introduction

In this Chapter the reactions of a variety of alkyl and aryl substituted phosphines with dimethyl chloramine and dimethyl bromamine are described. This study was performed in order to determine whether the reaction of trisdimethylaminophosphine with halamines, which gives the corresponding dihalo species and tetramethyl hydrazine (Section 7.16, (1)), has any parallel with the reactions of alkyl substituted phosphines with bulky alkyl groups. Also various phosphines partially substituted with the cyclohexyl group were oxidised to see if any parallel reaction to the fast decomposition of the tricyclohexyl dimethylamino phosphonium salts, described in Section 7.14 could be discovered, thus shedding further light on that reaction.

8.2 The reaction between diphenyl methyl phosphine and dimethyl chloramine

Diphenyl methyl phosphine (8.7 mmol) (FLUOROChemicals Limited) was dissolved in 4cm³ of dry petroleum ether inside a reaction vessel (Figure 2.2b) and 9.9 mmol of dry dimethyl chloramine condensed onto it. The vessel was kept at -23°C for five hours and then was allowed to warm to room temperature. The gas phase infrared spectrum of the most volatile fraction showed the presence of petroleum ether and dimethyl chloramine. These were pumped away through the vacuum line leaving a white solid which was removed from the cell and washed twice with petroleum ether inside the drybox. The ³¹Pnmr spectrum (Figure 63.) of the product dissolved in dichloro methane showed one sharp peak only at -51.6 p.p.m. due to the formation of a tetra coordinate phosphonium ion which is likely to be

$\text{Me}_2\text{NPPh}_2\text{MeCl}$. This cation and its chemical shift have not been reported before. The infrared spectrum of the product is shown in Figure 29 and the elemental analyses appear in Table 8.1.

Table 8.1

Element	Calculated for $\text{Me}_2\text{NPPh}_2\text{MeCl}$	Found
C	64.41	63.94
H	6.80	7.11
N	5.01	5.24
P	11.09	11.12
Cl	12.70	12.58

These results indicate that simple amination occurred to the phosphorus atom and the overall reaction can be represented by the following equation:

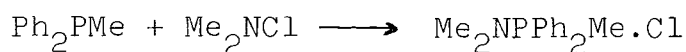

8.3 The reaction between diphenyl methyl phosphine and dimethyl bromamine

A sample of diphenyl methyl phosphine (7.3 mmol) was degassed and dissolved in 3cm^3 of dry degassed petroleum ether inside a reaction vessel (Figure 2.2b), and dry degassed dimethyl bromamine (9.1 mmol) condensed onto it at -196°C . The vessel was held at -23°C for seven hours and then allowed to warm to room temperature. The gas phase infrared spectrum showed a mixture of petroleum ether and dimethyl bromamine. These were pumped away leaving a yellow solid, which was washed three times with petroleum ether inside the drybox. The ^{31}P nmr spectrum of the product dissolved in dichloro methane

showed one sharp peak only at -51.6 p.p.m. This chemical shift is identical to that of $\text{Me}_2\text{NPPh}_2\text{Me}\cdot\text{Cl}$ prepared as described in Section 8.2. The elemental analyses are given in Table 8.2.

Table 8.2

Element	Calculated for $\text{Me}_2\text{NPPh}_2\text{MeBr}$	Found
C	55.57	55.01
H	5.87	6.20
N	4.32	4.64
P	9.57	9.49
Br	24.67	23.99

Thus the overall reaction is simple amination of the phosphorus atom:

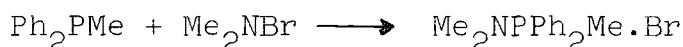

8.4 The preparation of dicyclohexylphenyl phosphine and cyclohexyl diphenyl phosphine

These phosphines were prepared by reacting cyclohexyl magnesium chloride with the corresponding chlorophenyl phosphine (106).

8.4.1 The preparation of cyclohexyl magnesium chloride

This compound was prepared by employing the general Grignard reaction procedure as described previously (107).

8.4.2 The preparation of dicyclohexyl phenyl phosphine

In a typical preparation cyclohexyl magnesium

chloride (195 mmol), was kept in the three-necked flask in which it had been prepared and 40cm³ of dry degassed ether was introduced into the flask. The central neck of the flask was equipped with a mechanical stirrer, one of the side necks was connected to a dry nitrogen line via a tap, and the third neck was equipped with a dropping funnel which was kept under dry nitrogen. Phenyl dichloro phosphine (195mmol), dissolved in 50cm³ of dry degassed ether, was syringed into the dropping funnel. This phosphine solution was added (over 30 minutes) to the Grignard solution, cooled to -6°C. stirring continuously. When the addition was completed the mixture was refluxed for about 20 minutes and cooled by using an ice-salt bath. The dropping funnel was charged with about 60cm³ of saturated aqueous ammonium chloride solution, which was added dropwise to the reaction mixture with continuous stirring. It was observed that the reaction mixture formed two layers, with the upper, ethereal layer containing the phosphine. This layer was isolated by filtration inside the drybox, and the solvent was removed by distillation. A white solid remained in the flask which, when dissolved in petroleum ether, showed one sharp peak in the ³¹Pnmr spectrum at -1.5 p.p.m. due to the formation of PhP(C₆H₁₁)₂ (δ=2.5 p.p.m.) (59). The analysis, shown in Table 8.3, is also in agreement with this formulation.

Table 8.3

Element	Calculated for C ₆ H ₅ P(C ₆ H ₁₁) ₂	Found
C	78.83	78.40
H	9.85	10.01
P	11.31	11.22

8.4.3 The preparation of cyclohexyl diphenyl phosphine

This preparation followed the procedure described in Section 8.4.2 for the preparation of dicyclohexyl phenyl phosphine except that 166.7 mmol of cyclohexyl magnesium chloride and 166.7 mmol of diphenyl chloro phosphine were used. Also at the end of the preparation, when the solvent was removed the product in this case was purified by recrystallisation, to produce a white solid. The ^{31}P nmr of this (dissolved in ether) showed one sharp peak only at 3.2 p.p.m. in good agreement with the literature value for $\text{Ph}_2\text{PC}_6\text{H}_{11}$ ($\delta = 4.4$ p.p.m.) (59).

The result of elemental analysis of this phosphine is given in Table 8.4.

Table 8.4

Element	Calculated for $(\text{C}_6\text{H}_5)_2\text{PC}_6\text{H}_{11}$	Found
C	82.13	81.89
H	6.08	6.41
P	11.79	11.68

8.5 The reaction between diphenyl cyclohexyl phosphine and dimethyl chloramine

Diphenyl cyclohexyl phosphine (6.4 mmol) was dissolved in 3cm³ of dry degassed petroleum ether, inside a reaction vessel (Figure 2.2b) and dry degassed dimethyl chloramine (8.1 mmol) condensed onto it at -196°C. The cell was held at -45°C for five hours, with occasional shaking, and then allowed to warm to room temperature. The gas phase infrared spectrum of the most volatile fraction showed a mixture of

petroleum ether and dimethyl chloramine. These were pumped away leaving a white solid, which was washed with petroleum ether three times inside the drybox. The ^{31}P nmr spectrum of the product dissolved in dichloromethane (Figure 64) showed one sharp peak only at -56.5 p.p.m. indicating the formation of a phosphonium ion. The chemical shift of this ion has not been reported before. The infrared spectrum of the product is shown in Figure 30 and the elemental analyses appear in Table 8.5.

Table 8.5

Element	Calculated for $\text{Me}_2\text{NPPh}_2(\text{C}_6\text{H}_{11})\text{Cl}$	Found
C	69.07	69.1
H	7.78	7.53
N	4.03	4.41
P	8.92	8.76
Cl	10.20	9.91

These results indicate that the reaction is a simple amination of the phosphorus atom:

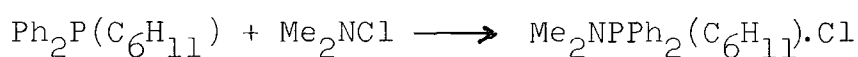

8.6 The reaction between diphenyl cyclohexyl phosphine and dimethyl bromamine

Diphenyl cyclohexyl phosphine was dissolved in 4cm^3 of dry degassed petroleum ether inside a reaction vessel (Figure 2.2b) and 7.2 mmol of dry degassed dimethyl bromamine condensed onto it. The cell was isolated and kept at -23°C for five hours with occasional shaking and then warmed to room temperature. The infrared spectrum of the most volatile fractions showed a mixture of petroleum ether and dimethyl

bromamine, which were pumped away through the vacuum line leaving an orange solid. This solid was washed three times with petroleum ether inside the drybox and its ^{31}P nmr spectrum (when dissolved in dichloro methane), showed one sharp peak only at -56.3 p.p.m. due to the formation of a tetra coordinate phosphorus species. This chemical shift is very close to that found for $\text{Me}_2\text{NPPh}_2(\text{C}_6\text{H}_{11})\cdot\text{Cl}$ ($\delta = -56.5$ p.p.m.) (Section 8.5). The elemental analyses are listed in Table 8.6.

Table 8.6

Element	Calculated for $\text{Me}_2\text{NPPh}_2(\text{C}_6\text{H}_{11})\text{Br}$	Found
C	61.24	60.79
H	6.89	7.21
N	3.57	3.94
P	7.91	7.83
Br	20.39	20.16

Thus the overall reaction is likely to be simple amination in the phosphorus atom:

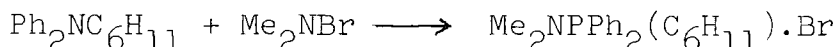

8.7 The reaction between phenyl dicyclohexyl phosphine and dimethyl chloramine

Phenyl dicyclohexyl phosphine (5.3 mmol) was dissolved in 3cm^3 of dry degassed petroleum ether inside a reaction vessel (Figure 2.2b) and 6.4 mmol of dry degassed dimethyl chloramine condensed onto it at -196°C . The vessel was held at -23°C for five hours with occasional shaking and, at this temperature, the formation of a white precipitate was observed. After the cell had been warmed to room temperature, the gas phase infrared spectrum showed a mixture of

of petroleum ether and dimethyl chloramine. These were pumped away through the vacuum line leaving a white solid which was washed three times with petroleum ether inside the drybox. The ^{31}P nmr spectrum of this solid (dissolved in dichloromethane) showed one sharp peak at -63.0 p.p.m. (Figure 65). This chemical shift indicates the formation of a tetra coordinate phosphonium ion. The infrared spectrum of the product is shown in Figure 31 and the elemental analyses appears in Table 8.7.

Table 8.7

Element	Calculated for $\text{Me}_2\text{NPPh}(\text{C}_6\text{H}_{11})_2\text{Cl}$	Found
C	67.90	66.98
H	9.34	10.02
N	3.96	4.21
P	8.77	8.73
Cl	10.03	10.11

These results support the following reaction:

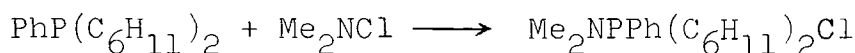

8.8 The reaction between phenyl dicyclohexyl phosphine and dimethyl bromamine

Phenyl dicyclohexyl phosphine (7.1 mmol) was dissolved in 4cm^3 of dry degassed petroleum ether inside a reaction vessel (Figure 2.2b) and 7.9 mmol of dry degassed dimethyl bromamine was condensed onto it at -196°C . The tube was kept at -45°C for five hours with occasional shaking and during this time the formation of a yellow precipitate was observed. The vessel was allowed to warm to room temperature and the gas phase infrared spectrum of the most volatile fraction was

run, which showed a mixture of petroleum ether and dimethyl bromamine. These were pumped away through the vacuum line leaving a yellow solid, which was washed three times with petroleum ether inside the drybox. The ^{31}P nmr spectrum of the solid dissolved in dichloro methane showed one sharp peak at -62.9 p.p.m., this chemical shift is within experimental error of the chemical shift found for $\text{Me}_2\text{NPPh}(\text{C}_6\text{H}_{11})_2\cdot\text{Cl}$ ($\delta = -62.9$ p.p.m., Section 8.7). The infrared spectrum of the product is very similar to that of $\text{Me}_2\text{NPPh}(\text{C}_6\text{H}_{11})_2\cdot\text{Cl}$. The elemental analysis results are listed in Table 8.8.

Table 8.8

Element	Calculated for $\text{Me}_2\text{NPPh}(\text{C}_6\text{H}_{11})_2\cdot\text{Br}$	Found
C	60.32	59.89
H	8.29	8.56
N	3.52	3.82
P	7.79	7.68
Br	20.08	19.21

These results indicate that the reaction is a simple amination of the phosphorus

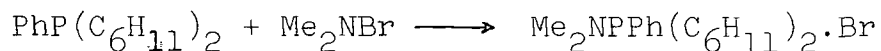

8.9 The reaction between bis(dimethylamino)phenyl phosphine and dimethyl chloramine

Bis(dimethylamino)phenyl phosphine (5.3 mmol) was dissolved in 4cm³ of dry degassed petroleum ether inside a reaction vessel (Figure 2.2b) and 6.6 mmol of dimethyl chloramine was condensed onto the mixture at -196°C. The cell was held at -45°C for five hours with occasional shaking and during this time the formation of a white precipitate was observed. The cell was allowed to warm to room temperature and the gas phase infrared spectrum of the most volatile fraction showed a mixture of petroleum ether and dimethyl chloramine. These were pumped away leaving a white solid which was washed three times with petroleum ether inside the drybox. The ³¹Pnmr spectrum of the solid dissolved in dichloro methane (Figure 66) showed one sharp peak only at -51.6 p.p.m. which is in the expected region for a four coordinate phosphonium ion and is within experimental error of the value found for (Me₂N)₃PPh.Br (δ = -51.4 p.p.m., (Section 8.10)). The infrared spectrum of the product is shown in Figure 32 and the elemental analyses are listed in Table 8.9.

Table 8.9

Element	Calculated for (Me ₂ N) ₃ PPh.Cl	Found
C	52.28	52.10
H	8.35	8.74
N	15.25	15.62
P	11.25	11.22
Cl	12.87	12.71

These results indicate that the overall reaction is:

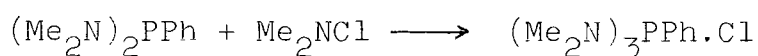

8.10 The reaction between bis(dimethylamino)phenyl phosphine and dimethyl bromamine

Bis(dimethylamino)phenyl phosphine (6.2 mmol) was dissolved in 5cm³ of dry degassed petroleum ether inside a reaction vessel (Figure 2.2b) and 7.3 mmol of dry and degassed dimethyl bromamine was condensed onto this mixture at -196°C. The vessel was kept at -45°C for five hours, with occasional shaking and during this time the formation of a yellow precipitate was observed. The cell was allowed to warm to room temperature and the gas phase infrared spectrum of the most volatile fraction was run, which showed a mixture of petroleum ether and dimethyl bromamine. These were pumped away through the vacuum line leaving a yellow solid which was washed four times with petroleum ether inside the drybox. The ³¹Pnmr spectrum of the solid dissolved in dichloromethane showed one sharp peak only at -51.4 p.p.m., which is within experimental error of the chemical shift found for (Me₂N)₃PPh.Cl (δ = -51.6 p.p.m., section 8.9). The elemental analyses are listed in Table 8.10.

Table 8.10

Element	Calculated for (Me ₂ N) ₃ PPhBr	Found
C	45.01	44.72
H	7.19	7.51
N	13.13	13.38
P	9.70	9.59
Br	24.98	24.59

These results indicate that simple amination of the phosphorus atom has occurred.

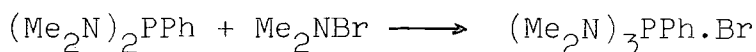

8.11 The reaction between dimethylamino diphenyl phosphine and dimethyl chloramine

A sample of dimethylamino diphenyl phosphine (4.9 mmol) was dissolved in 4cm³ of dry degassed petroleum ether inside a reaction vessel (Figure 2.2b) and 5.5 mmol of dimethyl chloramine was condensed onto the phosphine at -196°C. The vessel was kept at -23°C for five hours during which time a white precipitate formed. The cell was allowed to warm to room temperature and the gas phase infrared spectrum of the most volatile fraction was run, which showed a mixture of dimethyl chloramine and petroleum ether. These were pumped away through the vacuum line leaving a white solid, which was washed three times with petroleum ether inside the drybox. The ³¹Pnmr spectrum of this solid dissolved in dichloromethane showed one sharp peak at -50.0 p.p.m. (Figure 67) which indicates the formation of a phosphonium cation and is within experimental error of the chemical shift found for (Me₂N)₂PPh₂⁺.Br as described in Section 8.12. The elemental analyses are shown in Table 8.11.

Table 8.11

Element	Calculated for (Me ₂ N) ₂ PPh ₂ Cl	Found
C	62.25	61.98
H	7.13	7.49
N	9.08	9.87
P	10.05	10.14
Cl	11.49	11.47

These results imply that simple amination has occurred on the phosphorus atom:

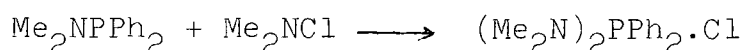

8.12 The reaction between dimethylamino diphenyl phosphine and dimethyl bromamine

A sample of dimethylamino diphenyl phosphine (6.1 mmol) was dissolved in 5cm³ of dry degassed petroleum ether inside a reaction vessel (Figure 2.2b) and 7.5 mmol of dry degassed dimethyl bromamine was condensed onto the phosphine at -196°C. The vessel was kept at -45°C for five hours with occasional shaking during which time a yellow precipitate was observed. The vessel was allowed to warm to room temperature and the gas phase infrared spectrum of the most volatile fraction showed a mixture of dimethyl bromamine and petroleum ether. These were pumped away leaving a yellow solid which was washed four times with petroleum ether in the drybox. The ³¹Pnmr spectrum of the solid dissolved in dichloromethane showed one sharp peak at -51.6 p.p.m. This chemical shift is (within experimental error) that of (Me₂N)₂PPh₂Cl (δ = 50.0 p.p.m., Section 8.11). The elemental analyses are listed in Table 8.12.

Table 8.12

Element	Calculated for (Me ₂ N) ₂ PPh ₂ ·Br	Found
C	54.41	53.62
H	6.23	6.66
N	7.93	8.02
P	8.78	8.74
Br	22.64	22.53

Thus the overall reaction is:

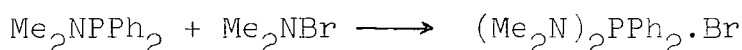

8.13 The reaction between dimethyl phenyl phosphine and dimethyl chloramine

A sample of dimethyl phenyl phosphine obtained from Fluorochemicals Limited (7.2 mmol) was dissolved in 4cm³ of dry degassed petroleum ether inside a reaction vessel (Figure 2.2b) and 8.4 mmol of dry degassed dimethyl chloramine was condensed onto the phosphine at -196°C. The cell was kept at -23°C for five hours with occasional shaking and then allowed to warm to room temperature. The infrared gas phase spectrum of the most volatile fraction showed the presence of a mixture of petroleum ether and dimethyl chloramine. These were pumped away through the vacuum line leaving a white solid which was washed three times with petroleum ether under dry nitrogen. The ³¹Pnmr spectrum of the product dissolved in dichloro methane showed one sharp peak only at -56.5 p.p.m. which indicates the formation of a phosphonium ion and is within the experimental error of the value found for Me₂NPPhMe₂ Br (δ = -54.9 p.p.m. Section 8.14). The elemental analyses appear in Table 8.13.

Table 8.13

Element	Calculated for Me ₂ NPPhMe ₂ .Cl	Found
C	55.19	53.98
H	7.82	8.11
N	6.44	6.62
P	14.26	14.30
Cl	16.30	16.47

These results indicate that the reaction is:

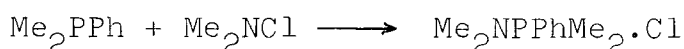

8.14 The reaction between dimethyl phenyl phosphine and dimethyl bromamine

A degassed sample of dimethyl phenyl phosphine (5.8 mmol) was dissolved in 5cm³ of dry degassed petroleum ether in a reaction vessel (Figure 2.2b) and 6.6 mmol of dry degassed dimethyl bromamine was condensed onto it at -196°C. The vessel was kept at -45°C for five hours with occasional shaking and the formation of a yellow precipitate was observed. The vessel was allowed to warm to room temperature and the gas phase infrared spectrum of the most volatile fraction was run, which showed a mixture of dimethyl bromamine and petroleum ether. These were pumped away through the vacuum line leaving a yellow solid which was washed three times with petroleum ether inside the drybox. The ³¹Pnmr spectrum of the solid dissolved in dichloro methane showed one sharp peak only at -54.9 p.p.m. which is (within experimental error) the value for Me₂NPPhMe₂.Cl (δ = -56.5 p.p.m. Section 8.13). The elemental analyses are listed in Table 8.14.

Table 8.14

Element	Calculated for Me ₂ NPPhMe ₂ Br	Found
C	45.82	45.51
H	6.49	6.87
N	5.35	5.94
P	11.84	11.79
Br	30.51	29.98

These results indicate that simple amination had occurred on the phosphorus atom to produce a phosphonium salt:

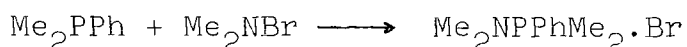

8.15 The reaction between excess white phosphorus and dimethyl chloramine

A sample of white phosphorus (12.5 mmol), (Fisons Scientific Ltd.) was dissolved in 4 cm³ of degassed carbon disulphide inside a reaction vessel (Figure 2.2b). Dimethyl chloramine (5.3 mmol) was condensed onto the mixture at -196°C. The vessel was kept at -30°C (the freezer temperature) for seventeen days. The gas phase infrared spectrum of the most volatile fraction showed the presence of carbon disulphide only. The ³¹Pnmr spectrum of the product dissolved in carbon disulphide showed three peaks, one at -164.6 p.p.m. due to the formation of Me₂NPCl₂ (51), a second peak at -53.3 p.p.m. due to the formation of (Me₂N)₃PCl⁺.Cl⁻ (1) and a third peak at 468 p.p.m. due to the white phosphorus. This result implies that the overall reaction is:

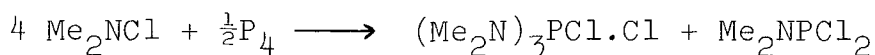

8.16 The reaction between white phosphorus and excess dimethyl chloramine

The reaction was carried out by using the same technique described in Section 8.15. The amounts of the reactants were 3.7 mmol of white phosphorus and 19.4 mmol of dimethyl chloramine. After the vessel had been kept at -30°C for two weeks (with occasional shaking), it was allowed to warm to room temperature and the gas phase infrared spectrum was run of the most volatile fraction. This showed the presence of a mixture of Me₂NCl and CS₂. These were pumped away leaving a white solid, the ³¹Pnmr spectrum of which (dissolved in dichloromethane) showed one peak at -53.3 p.p.m. The

elemental analysis was consistent with the formula $(\text{Me}_2\text{N})_5\text{P}_2\text{Cl}_5$ as shown in Table 8.15.

Table 8.15

Element	Calculated for $(\text{Me}_2\text{N})_5\text{P}_2\text{Cl}_5$	Found
C	26.13	25.01
H	6.53	7.8
N	15.24	15.64
P	13.50	13.21
Cl	38.60	36.19

These results imply the formation of a mixture of $(\text{Me}_2\text{N})_3\text{PCl}_2$ and $(\text{Me}_2\text{N})_2\text{PCl}_3$ the chemical shifts of which are very close to each other and have been observed at -53.3 p.p.m. and -51.6 p.p.m. (1). To confirm this a sample of the product was exposed to wet nitrogen for 6 days. In this way the sample was converted to a colourless liquid, the nmr of which showed two sharp peaks only at -22.5 p.p.m. due to the formation of $(\text{Me}_2\text{N})_3\text{P}=\text{O}$ (108) and at -30.7 p.p.m. due to the formation of $(\text{Me}_2\text{N})_2\text{POCl}$ (109).

This result proved that the reaction of excess Me_2NCl with white phosphorus produced an equivalent mixture of $(\text{Me}_2\text{N})_3\text{PCl}^+\text{Cl}^-$ and $(\text{Me}_2\text{N})_2\text{PCl}_2^+\text{Cl}^-$. These, when hydrolysed produced $(\text{Me}_2\text{N})_3\text{P}=\text{O}$ and $(\text{Me}_2\text{N})_2\text{POCl}$. It is possible to represent the overall reaction as:

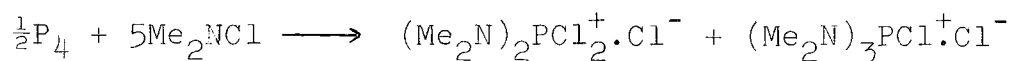

8.17 Results and Discussion

The results of the reactions described in this chapter imply that the phosphines have been aminated by the halamines possibly via an S_N2 attack by the phosphorus atom on the nitrogen of the halamine, e.g.:

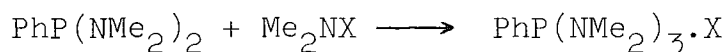
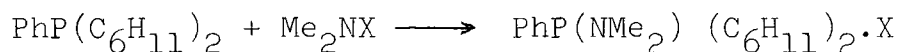

Even when $(\text{C}_6\text{H}_{11})_3\text{P}$ was reacted with Me_2NCl as described in the previous chapter it produced initially a phosphonium ion (most likely by amination) which decomposed rapidly at room temperature. This is most likely because no tetramethylhydrazen was detected in the product. None of the reactions described in this chapter was parallel to the reactions between $(\text{Me}_2\text{N})_3\text{P}$ and Me_2NBr described in Chapter Seven. This may be attributed to the steric factor more than the electronic factor, since the tris(dimethylamino)phosphine is more bulky than any one of the phosphines reacted with Me_2NX as described in Chapters Seven and Eight, but it is not the most basic one. That is because some of the phosphines which were reacted with Me_2NX in Chapter Seven are more basic, e.g. Me_3P and Ph_3P (110).

In the tris(dimethylamino)phosphine molecule there are three dimethylamino groups linked to the phosphorus causing greater steric hindrance than that produced around the phosphorus atoms of the phosphines used in the reactions described in Chapter Eight. Thus it is most likely that steric effects play a significant role in determining the course of the reaction.

The reaction between white phosphorus (P_4) and Me_2NCl produced $(Me_2N)_3PCl.Cl$ and Me_2NPCl_2 when white phosphorus was used in excess. The white phosphorus molecule (P_4) has a strained tetrahedral structure. This will make the cleavage of the P-P bond by dimethyl chloramine relatively easy. This reaction could be in some stage parallel to the iodination of P_4 to produce P_2I_4 (92), i.e. $\frac{1}{2}P_4 + 2Me_2NCl \longrightarrow Me_2N-\overset{Cl}{P}-\overset{Cl}{P}-NMe_2$

The P-P bond is very weak and it has been reported that halogen readily cleaves it (111):

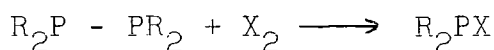

Consequently it is assumed that Me_2NCl reacted with the bisphosphine as:

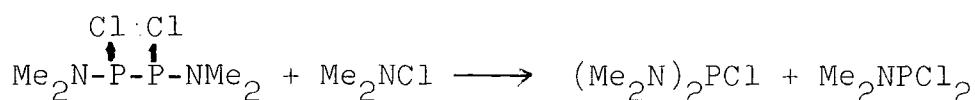

Since $(Me_2N)_2PCl$ is more basic than Me_2NPCl_2 it will react first with Me_2NCl to produce $(Me_2N)_3PCl.Cl$ (1).

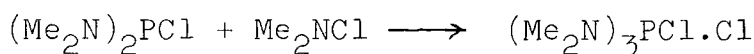

Thus the ^{31}P nmr spectrum of the reaction between excess white phosphorus and dimethyl chloramine showed the presence of $(Me_2N)_3PCl.Cl$, Me_2NPCl_2 and white phosphorus, but it did not show a peak due to the bisphosphine which is likely to be more reactive towards the chloramine than the white phosphorus. When this reaction was carried out using excess of the chloramine the phosphine observed before reacted with the chloramine (1):



Consequently the overall reaction was represented by the equation:

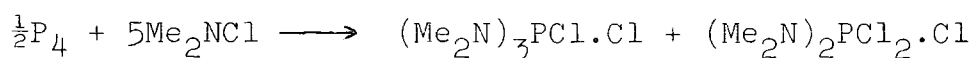

CHAPTER NINE

THE EFFECT OF LIQUID HYDROGEN CHLORIDE ON
A VARIETY OF P-N PHOSPHONIUM SALTS

9.1 Introduction

During previous studies in this laboratory (1) it has been found that liquid hydrogen chloride at -98°C dissolved $\text{Me}_2\text{NPCl}_3^+ \text{PCl}_6^-$ but did not cleave the P-N bond since the same species was recovered when the hydrogen chloride was evaporated. Presumably the anion reacted to form the tetrachloro phosphonium ion as has been demonstrated by Raman spectroscopy (112).

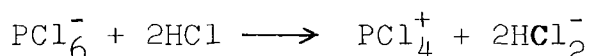

It was found that the P-N bond was cleaved when the acidity of the system was increased by the addition of boron trichloride:

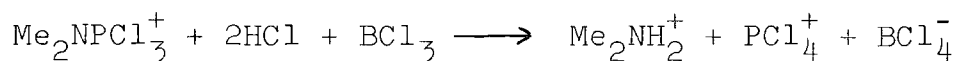

Consequently it was decided to study the stability of other systems containing P-N bonds and some other phosphorus species to see how substituents on the phosphorus changed the stability of the cation to react with hydrogen chloride.

9.2 The Purification of hydrogen chloride

A bulb of ten litre capacity with a cooled finger was evacuated and connected separately to a mercury bubbler and to a hydrogen chloride cylinder (BOC special gases). The valve of the cylinder was released gently so that hydrogen chloride replaced the air and filled the connections between the cylinder and the valve of the bulb and pass out through the bubbler. The valve of the bulb was then slowly opened to allow the hydrogen chloride to fill it. When the bulb was full of gas it was connected to the fractionation section

of the vacuum line (Figure 2.1) and the hydrogen chloride degassed. The hydrogen chloride was fractionated through traps at -83°C , -112.5°C and -196°C . It was noted that a considerable amount was trapped at -112.5°C while about 0.5 cm^3 of colourless liquid of relatively high boiling point was trapped at -83°C which was presumably hydrogen chloride hydrate. No significant quantity of material was trapped at -196°C . The gas phase infrared spectrum of the fraction trapped at -112.5°C showed bands due to hydrogen chloride only. The purified HCl was stored either in the ten litre bulb or inside one of the traps of the fractionation section at liquid air temperature.

9.3 The reaction between liquid hydrogen chloride and dimethyl amino-triphenyl phosphonium chloride

Inside the drybox a sample of dimethylaminotriphenylphosphonium chloride (1.6 mmol) which had been prepared by reacting dimethyl chloramine with triphenyl phosphine as described in Section 7.2, was introduced into a modified nmr tube made of silica with a constriction (Figure 2.5). A sample of the purified HCl was condensed into a calibrated cooled finger (Figure 2.5) and warmed to -112.5 in order to measure its volume (2.8 cm^3). The liquid hydrogen chloride was transferred onto the phosphonium salt and the tube sealed off under vacuum and allowed to warm to room temperature inside a steel cylinder placed inside a fumes hood. The tube was warmed to 40°C for five minutes to make sure that it could stand the pressure at that temperature (the temperature of the nmr probe). A clear colourless solution was observed and its ^{31}P nmr spectrum

showed one sharp peak only at -66.2 p.p.m. due to the formation of Ph_3PCl^+ ($\delta = -66.2$ p.p.m. (113)). This result shows that liquid HCl had cleaved the phosphorus nitrogen bond of the cation and that the overall reaction was:

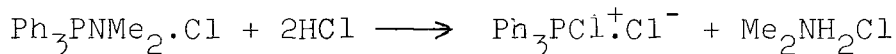

9.4 The reaction between liquid hydrogen chloride and bis(dimethylamino)diphenyl phosphonium chloride

This reaction was carried out using the same technique as described in Section 9.3. The amounts of the reactants used were 1.3 mmol of the phosphonium salt prepared by reacting diphenyl dimethylamino phosphine with dimethyl chloramine as described in Section 4.8 and 2.5 cm³ of purified HCl. The ³¹Pnmr spectrum of the solution run after the ampoule had been kept at room temperature for three hours showed one sharp peak at -71.5 p.p.m. due to the formation of $\text{Ph}_2\text{PNMe}_2\text{Cl}^+$ which had previously been prepared by the chlorination of Ph_2PNMe_2 as described in Section 4.3 when its chemical shift had been found to be -70.9 p.p.m. in solution in dichloromethane. This result shows that liquid hydrogen chloride cleaved one of the P-N bonds:

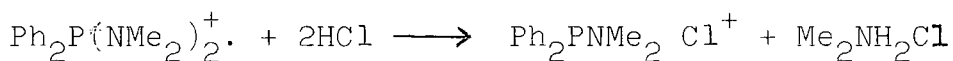

After the tube had been left at room temperature for fifteen hours, the ³¹Pnmr spectrum of its contents showed one sharp peak only at -93.5 p.p.m. due to the formation of $\text{Ph}_2\text{PCl}_2^+$ ($\delta = -93.5$ p.p.m.)

This result indicates that hydrogen chloride slowly cleaved the second phosphorus nitrogen bond at room temperature:

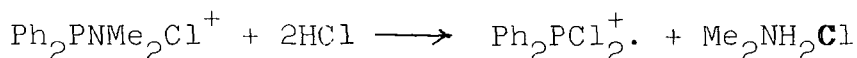

and that the overall reaction could be represented as:

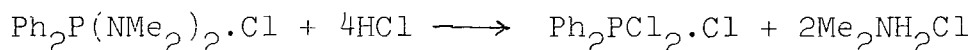

9.5 The reaction between tris(dimethylamino)phenyl phosphonium chloride and liquid hydrogen chloride

The reaction between tris(dimethylamino)phenyl phosphonium chloride and liquid hydrogen chloride was carried out by employing the technique described in Section 9.3. The phosphonium salt was prepared by reacting bis(dimethylamino)phenyl phosphine with dimethyl chloramine as described in Section 8.9. The amounts of the reactants used were 1.5 mmol of the phosphonium salt and 3.2 cm³ of the purified hydrogen chloride. A clear colourless solution was noted and its ³¹Pnmr spectrum run shortly after the tube had been warmed to room temperature showed one sharp peak at -51.6 p.p.m. due to the starting material. After the tube had been left at room temperature for two days the ³¹Pnmr spectrum showed two sharp peaks; a major one at -51.6 p.p.m. due to the starting material and a minor one at -72.1 p.p.m. due to the formation of PhP(NMe₂)₂Cl⁺. This phosphonium ion had previously been prepared by the chlorination of Ph P(NMe₂)₂ as described in Section 4.5, and its chemical shift had been measured as -74.1 p.p.m. in solution in dichloromethane. The tube was kept at room temperature for fourteen days and its ³¹Pnmr spectrum showed one sharp peak only at -101.0 p.p.m. due to the formation of PhPCl₃⁺ (δ = -103.1 p.p.m.) (113). This result shows that liquid hydrogen chloride had cleaved the phosphorus nitrogen bond of PhP(NMe₂)₂Cl·Cl:

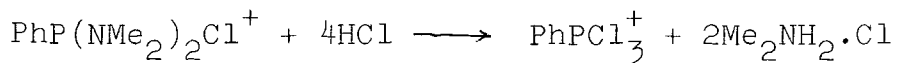

and that the overall reaction between $\text{PhP}(\text{NMe}_2)_3\cdot\text{Cl}$ and HCl could be represented as:

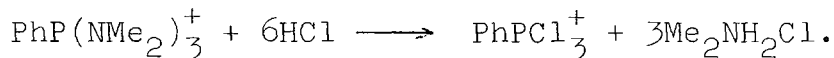

9.6 The reaction between tris(dimethylamino)chloro phosphonium chloride and liquid hydrogen chloride

This reaction was carried out by applying the same technique employed in reacting dimethylamino triphenyl phosphonium chloride with liquid hydrogen chloride as described in Section 9.3. Tris(dimethylamino)chloro phosphonium chloride was prepared by reacting bis(dimethylamino)chloro phosphine with dimethyl chloramine (1). The amounts of the reactants were, 1.2 mmol of the phosphonium salt and 3.2 cm³ of purified HCl. A colourless solution was noted inside the tube and the ³¹Pnmr spectrum of the solution showed one sharp peak only at -53.3 p.p.m. due to the starting material. The tube was kept at room temperature for sixteen hours and the ³¹Pnmr spectrum showed that no change had occurred. The ³¹Pnmr spectrum of the solution was run after 35 days and still no change was observed in the spectrum. This result implies that liquid hydrogen chloride did not cleave any of the three P-N bonds of this phosphonium salt.

9.7 The reaction between hexamethyl phosphoramidate and liquid hydrogen chloride

This reaction was carried out by applying the same technique as described in Section 9.3. Hexamethylphosphoramidate was purchased from BDH Ltd. and its purity checked by ^{31}P nmr. The amounts of reactants used were 0.8 cm^3 of the amide and 2.5 cm^3 of liquid hydrogen chloride. The ^{31}P nmr spectrum of the reaction mixture showed one sharp peak only at -30.3 p.p.m. due to the formation of $(\text{Me}_2\text{N})_2\text{POCl}$. This result implies that liquid hydrogen chloride cleaved one of the three phosphorus nitrogen bonds of the amide:

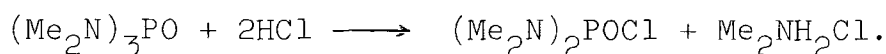

The tube had been left at room temperature for 24 hours and the ^{31}P nmr spectrum showed two peaks, a major one at -30.3 p.p.m. due to $(\text{Me}_2\text{N})_2\text{POCl}$ and a minor one at -15.8 p.p.m. due to the formation of $\text{Me}_2\text{NPOCl}_2$, the integration ratio being 7:1. This result indicates that a further slow solvolysis of $(\text{Me}_2\text{N})_2\text{POCl}$ was occurring:

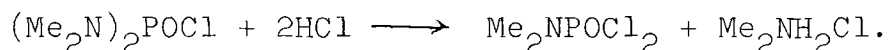

After five days the ^{31}P nmr spectrum showed one sharp peak at -15.6 p.p.m. , indicating that further reaction with hydrogen chloride to produce phosphorus oxychloride was not occurring significantly. The tube was kept at room temperature for a further 21 days and the ^{31}P nmr spectrum showed one sharp peak only at -1.6 p.p.m. due to the formation of POCl_3 :

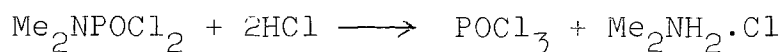

Thus the final conclusion is that liquid hydrogen chloride slowly cleaves the three phosphorus nitrogen bonds of the amide; the rate of reaction falling off markedly as the amine

group is substituted by chlorine:

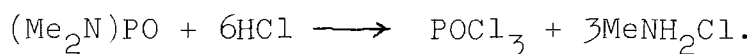

9.8 The reaction between bis(dimethylamino)dichloro phosphonium chloride and liquid hydrogen chloride

The technique used for the reaction between bis(dimethylamino)dichloro phosphonium chloride and liquid hydrogen chloride parallels that described in Section 9.3. The phosphonium salt was prepared by reacting dimethylamino dichloro phosphine with dimethyl chloramine (1). The amounts of the reactants used were 1.01 mmol of the phosphonium salt and 2.9 cm³ of purified liquid hydrogen chloride. A clear colourless solution was observed inside the tube and its ³¹Pnmr spectrum showed one sharp peak only at -51.6 p.p.m. due to the starting material P(NMe₂)₂Cl₃. The tube was kept at room temperature for 6 days and the nmr spectrum showed a minor peak at -61.3 p.p.m. due to the formation of the dimethyl amino trichloro phosphonium ion (1,), whereas the major peak was one due to the starting material. The integration ratio was 1:11. After a month the nmr spectrum showed two peaks, one at -51.6 p.p.m. due to the starting material and another peak of the same intensity at -60.3 p.p.m. due to the formation of Me₂NPCl₃⁺. This result indicated that some of the starting material had reacted with liquid HCl cleaving one of the phosphorus nitrogen bonds of the phosphonium ion in a slow reaction:

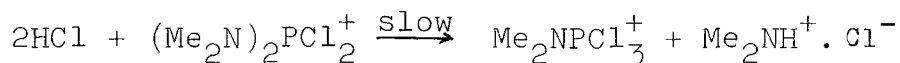

When the tube had been left for a further two weeks a large amount of white crystalline solid was observed to fill 3/4 of the volume of the tube and the ^{31}P nmr spectrum showed the presence of the following phosphorus species (i) a peak at -51.6 p.p.m. due to the starting material, (ii) a peak at -60.3 p.p.m. due to the formation of $\text{Me}_2\text{NPCl}_3^+\text{Cl}^-$, (iii) a peak at 302.1 p.p.m. due to the formation of PCl_6^- ($\delta = 300$ p.p.m.)(115). The previous three peaks were broad ones due to a solid phase spectrum. The result implies the P-N bond of $\text{Me}_2\text{NPCl}_3^+$ was cleaved by liquid hydrogen chloride. The rate of this reaction would be faster if the reactants were not in a solid phase. The overall reaction can be represented as:

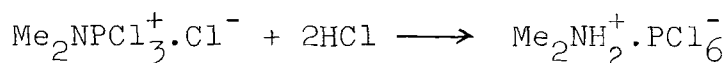

Thus it is possible to write the following equation to represent the reaction between bis(dimethylamino)dichloro phosphonium chloride and liquid hydrogen chloride:

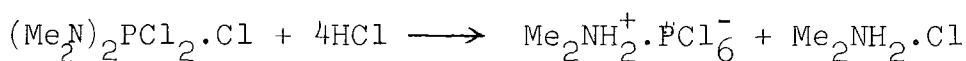

The results obtained above show that liquid hydrogen chloride cleaved the phosphorus nitrogen bonds of $(\text{Me}_2\text{N})_2\text{PCl}_2^+$.

9.9 The reaction between trimethyl dimethylamino phosphonium chloride salts and liquid hydrogen chloride

This reaction has been carried out by applying the technique described in Section 9.3. Trimethyl dimethylamino phosphonium chloride salt was prepared by reacting trimethyl phosphine and dimethyl chloramine as described in Section 7.11. The amounts of the reactants used are 1.4 mmol of the phosphonium

salt and 2.6 cm³ of the purified liquid hydrogen chloride. The ³¹Pnmr spectrum of the liquid inside the tube showed one sharp peak at - 88 p.p.m. due to the formation of Me₃PCl⁺. (113) This implies that liquid hydrogen chloride cleaved the P-N bond of the phosphonium salt:



9.10 The reaction between dimethylamino dimethylchloro phosphonium chloride salt and liquid hydrogen chloride

The reaction between dimethylamino dimethyl chloro phosphonium chloride salt and liquid hydrogen chloride was carried out by employing the same techniques described in Section 9.3. The phosphonium salt was prepared by reacting dimethyl chloramine with dimethyl chloro phosphine as described in Section 6.2 .

The amount of the phosphonium salt used was 1.9 mmol and that of liquid hydrogen chloride was 2.4 cm³. The ³¹Pnmr spectrum of the colourless liquid observed inside the tube showed one sharp peak at -131.6 p.p.m. due to the formation of Me₂PCl₂⁺ (δ = -121.0 p.p.m. (113)). This result shows that liquid hydrogen chloride had cleaved the phosphorus nitrogen bond of the phosphonium salt:

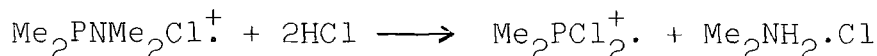

9.11 The reaction between dimethylamino methyl dichloro phosphonium chloride and liquid hydrogen chloride

This reaction was carried out using the same technique described in Section 9.3. The phosphonium salt was prepared

by reacting dimethyl chloramine with methyl dichloro phosphine as described in Section 6.4 . The amount of dimethylamino methyl dichloro phosphonium chloride used was 1.5 mmol and that of hydrogen chloride was 2.5 cm³. A colourless liquid was observed inside the tube, the ³¹Pnmr spectrum of this liquid showed one sharp peak at -122.1 p.p.m. due to the formation of Me-PCl₃⁺ (δ = -120.0 p.p.m. (113)). This result indicated that liquid hydrogen chloride had cleaved the P-N bond of the phosphonium salt and the overall reaction was:

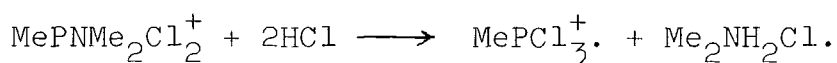

9.12 The reaction between tris(methoxy)phosphine oxide (methyl phosphate) and liquid hydrogen chloride

The reaction between tris(methoxy)phosphine oxide and liquid hydrogen chloride was carried out by employing the same technique described in Section 9.3. The amounts of the reactants used were 0.9 cm³ of the phosphine oxide used as purchased, the purity having been checked by ³¹Pnmr, (Ralph N. Emmanuel Ltd.) and 3.2 cm³ of the purified liquid hydrogen chloride. The initial ³¹Pnmr spectrum of the reaction mixture showed one sharp peak at 1.5 p.p.m. (116) due to the starting material. The tube was kept at room temperature for one day and the ³¹Pnmr spectrum still showed only the peak due to the starting material. The ³¹Pnmr spectra were studied daily for three weeks and no change was observed. This result implies that liquid hydrogen chloride does not react with tris(methoxy)phosphine oxide.

9.13 Results and Discussion

It is possible to conclude from the work described in this chapter that liquid hydrogen chloride reacted with the phosphonium salts of the molecular formula $Y_{(4-n)}P(NMe_2)_n^+$, ($n=1,2,3$ and $Y=Ph, Me,$ or Cl) where it was found that the P-N bond or bonds were cleaved producing $Y_{(4-n)}PCl_n^+$ and dimethyl ammonium chloride. The one exception to this is the reaction between tris(dimethylamino)chloro phosphonium chloride and liquid hydrogen chloride. The likely mechanism of this reaction is an S_N2 attack on the phosphorus atom by chloride ion, preceded perhaps by protonation of one of the nitrogens:

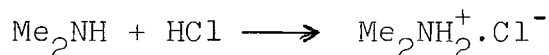
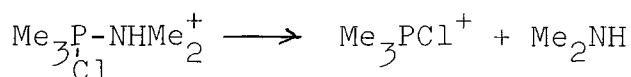
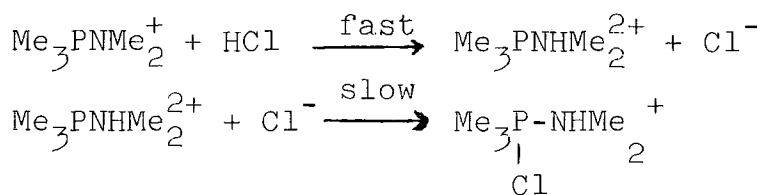

In order to *suggest* that protonation occurs before the chloride ion attacks the phosphorus in an S_N2 mechanism, $(Me_2N)_3PO$ and $(MeO)_3PO$ were reacted with liquid hydrogen chloride. The reaction between $(Me_2N)_3PO$ and liquid HCl occurred and the final products are:

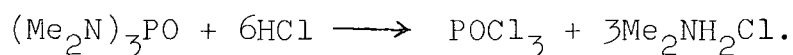

The dimethylamino groups are electron donating, and the lone pair of electrons on each nitrogen atom would interact with 3d orbitals of the phosphorus atom.

This would make the bond between P-N partially a π bond P-N due to delocalisation of the lone pair of electrons.

Despite this partial delocalization of the lone pairs of electrons of the nitrogen atoms they were vulnerable to protonation.

When $(\text{MeO})_3\text{P}=\text{O}$ was reacted with liquid HCl no reaction was observed. The MeO is electron withdrawing group, thus there will be no electron interaction between the lone pairs of electrons of the oxygen atoms and 3d orbitals of the phosphorus atom. This would help in making the phosphorus atom of $(\text{MeO})_3\text{PO}$ to be in a more vulnerable position to chlorination than that of $(\text{Me}_2\text{N})_3\text{P}=\text{O}$, yet no reaction occurred. This result indicated that cleavage of the P-N bond by liquid HCl must be initiated by protonation of the nitrogen atom as illustrated above. It was observed that the more the dimethylamino groups linked to the phosphorus atom the slower the reaction rate was, e.g. the reaction between $\text{Ph}_3\text{PNMe}_2^+$ and liquid HCl is faster than the parallel reaction with $\text{Ph}_2\text{P}(\text{NMe}_2)^+$, which itself was faster than the reaction of $\text{PhP}(\text{NMe}_2)^+$. This may be attributed to the fact that the more dimethylamino groups linked to the phosphorus atom the more the interaction between the electrons and the 3d orbitals of the phosphorus atom and this would slow down the rate of the chlorination of the phosphorus atoms by the chloride ions. In the reaction between $(\text{Me}_2\text{N})_3\text{PCl}^+$ and liquid HCl there was no reaction - this could be attributed to the nitrogen lone pairs interacting with the 3d orbitals of the phosphorus atom, with the presence of three-dimethyl amine groups enhancing this factor. When $(\text{Me}_2\text{N})_2\text{PCl}^+$ was reacted with HCl the reaction occurred and it was a slow one as described in Section 9.7. This reaction probably occurred because there are two dimethylamino groups only and the phosphorus atom is linked

to the chlorine atoms which will withdraw the electronic cloud around the phosphorus atom through the δ bonds making the phosphorus atom on a good site to be attacked by the partially negative charged chlorine of HCl.

CHAPTER TEN

THE PREDICTION OF THE CHEMICAL SHIFTS FOR
A VARIETY OF PHOSPHONIUM IONS

10.1 Introduction

Different workers have shown in their studies of the nmr spectra of several types of compounds, that the chemical shift of the central nuclei are pairwise additive with respect to the substituent groups (117), Vladimiroff and Malinowski (118) have produced a theoretical justification for this relationship.

Several teams of workers have used this rule to predict the chemical shift of compounds, and to distinguish between *cis* and *trans* geometric isomers. The chemical shifts of the mixed tetrahaloaluminate ions were measured by Kidd and Truax (119) and they found that each halogen did not introduce a constant increment to the aluminium shielding. They explained this variation by suggesting that the contribution of each halogen is dependent upon the other substituents bonded to aluminium, but *no* explanation about the nature of this dependency was offered. Malinowski (117) succeeded in proving that Al^{27} shifts of the tetrahaloaluminate ions obeyed pairwise additivity.

Boron-11, fluorine-19 (118), germanium-73 (120) and carbon -13 (121) were also found to obey the pairwise additivity rule.

The other benefit of applying this rule was utilised when its use was extended from predicting the chemical shift of four-coordinate species to identifying, in solution, the presence of specific geometric isomers of six-coordinate complexes, by predicting their chemical shifts. Examples for this application are the identification of hexahaloniobate V (126) and hexachlorophosphates $PF_nCl_{6-n}^-$ (89) isomers.

10.2 The prediction of chemical shifts of phenyl chloro substituted phosphonium ions $\text{Ph}_n\text{PCl}_{4-n}^+$ ($n=1,2,3$)

It is possible to predict the chemical shift of these phosphonium ions if the values of pairwise parameters for following substituents are known $n\text{Ph,Ph}$, $n\text{Ph,Cl}$ and $n\text{Cl,Cl}$. The values of these substituents can be obtained by applying the pairwise additive rule to Ph_4P^+ , Ph_3PCl^+ and PCl_4^+ as shown in Table 10.1

Table 10.1

The Phosphonium ion	Reported δ p.p.m.	Pairwise Additivity	Substituents	Pairwise n parameters p.p.m.
Ph_4P^+	-20.8	$6n\text{Ph,Ph}$	Ph,Ph	-3.47
Ph_3PCl^+	-66	$3n\text{Ph,Ph} + 3n\text{Ph,Cl}$	Ph,Cl	-18.53
PCl_4^+	-87	$6n\text{Cl,Cl}$	Cl,Cl	-14.5

By applying the pairwise additivity model it is possible to predict the chemical shift of $\text{Ph}_2\text{PCl}_2^+$:

The chemical shift of $\text{Ph}_2\text{PCl}_2^+ = 4n\text{Ph,Cl} + n\text{Cl,Cl} + n\text{Ph,Ph}$

$$\text{of } \text{Ph}_2\text{PCl}_2^+ = 4(-18.53) + (-3.47) + (-14.5) = 92.09 \text{ p.p.m.}$$

The reported chemical shift is -90 p.p.m. the difference between the predicted and the reported chemical shift could be within the area of the experimental error.

The chemical shift of $\text{PhPCl}_3^+ = 3n\text{Cl,Cl} + 3n\text{Ph,Cl}$

$$= 3(-14.5) + 3(-18.53) = -99.09 \text{ p.p.m.}$$

The predicted chemical shift is in good agreement with the reported one at -100.0 p.p.m. (113).

10.3 The prediction of the chemical shifts of some $\text{Me}_n\text{PCl}_{(4-n)}^+$ ($n=1,2,3$) cations

It is possible to predict the chemical shift of these phosphonium ions, when the values of the following pairwise parameters are calculated: $n\text{Cl},\text{Cl}$, $n\text{Me},\text{Cl}$ and $n\text{Me},\text{Me}$ as shown in Table 10.2.

Table 10.2

(alc.	Phosphonium ion	Reported δ p.p.m.	Reference	Substituent used in calculation	Pairwise parameter, n p.p.m.
	PCl_4^+	-87	122	Cl,Cl	-14.5
	Me_4P^+	-24	123	Me,Me	-4.0
	MePCl_3^+	-117	113	Me,Cl	-24.5
-116.5	$\text{Me}_2\text{PCl}_2^+$	-121	113		
-88.5	Me_3PCl^+	-87	113		

The chemical shift of $\text{Me}_2\text{PCl}_2^+ = 4 n\text{Me},\text{Cl} + n\text{Cl},\text{Cl} + n\text{Me},\text{Me} = -116.5$ p.p.m.

The chemical shift of $\text{Me}_3\text{PCl}^+ = 3n\text{Me},\text{Me} + 3n\text{Me},\text{Cl} = -88.5$ p.p.m.

It is apparent from the data that $\text{Me}_n\text{PCl}_{(4-n)}^+$ phosphonium ions obey the pairwise additivity rule.

10.4 The prediction of the chemical shift of $\text{PhPNMe}_2\text{Me}_2^+$

It was interesting to attempt to apply the pairwise additivity rule to some groups of phosphonium ions prepared as described in the present work. Table 10.3 shows the chemical shift of some of these phosphonium ions and the values of the pairwise interaction parameters needed to predict the chemical shift of $\text{PhPNMe}_2\text{Me}_2^+$.

Table 10.3

<i>Calc</i>	Phosphonium ion	Observed δ p.p.m.	Reported δ p.p.m.	Reference	Substituent used in calculation	Pairwise parameter p.p.m.
	PMe_4^+		-24	123	Me, Me	-4
	Ph_4P^+		-20.8	124	Ph, Ph	-3.47
	$\text{Ph}_3\text{PNMe}_2^+$	-46.7		125	Ph, NMe_2	-12.1
	Ph_3PMe^+		-23	123	Ph, Me	-4.2
	$\text{Ph}_2\text{PNMe}_2\text{Me}^+$	-51.6			$\text{Me}_2\text{N}, \text{Me}$	-15.53
-55.6	$\text{PhPNMe}_2\text{Me}_2^+$	-56.5				

$$\begin{aligned} \text{The chemical shift of } \text{PhPNMe}_2\text{Me}_2^+ &= 2\eta_{\text{Ph, Me}} + 2\eta_{\text{Me}_2\text{N, Me}} + \eta_{\text{Me, Me}} \\ &\quad + \eta_{\text{Ph, NMe}_2} \\ &= -55.6 \text{ p.p.m.} \end{aligned}$$

The predicted chemical shift is in very good agreement with that found practically ($\delta = -56.5$ p.p.m.). This implies that the phosphonium ions listed in Table 10.3 obey the pairwise additivity rule.

10.5 The prediction of the chemical shift of $(\text{Me}_2\text{N})_3\text{PCl}^+$

To predict the chemical shift of tris(dimethylamino) chloro phosphonium ion by employing the pairwise additivity rule it is necessary to know the values of the pairwise parameter (p.p.m.) of the following substituents $\eta_{\text{Cl, Cl}}$, $\eta_{\text{Me}_2\text{N, Cl}}$ and $\eta_{\text{Me}_2\text{N, NMe}_2}$. Table 10.4 shows the phosphonium ions and their chemical shifts used in calculating the values of the pairwise parameters of the substituents mentioned above.

Table 10.4

<i>Calc.</i>	Phosphonium ion	Observed δ p.p.m.	Reported δ p.p.m.	Reference	Substituent used in calculation	Pairwise parameter, p.p.m.
	PCl_4^+	-87.0	-87.1	122	Cl,Cl	-14.5
	$\text{Me}_2\text{NPCl}_3^+$	-61.3	-61.3	1 114	$\text{Me}_2\text{N},\text{Cl}$	-5.93
	$(\text{Me}_2\text{N})_2\text{PCl}_2^+$	-51.6			$\text{Me}_2\text{N},\text{NMe}_2$	-13.38
-57.9	$(\text{Me}_2\text{N})_3\text{PCl}^+$	-53.3				

The chemical shift predicted for $(\text{Me}_2\text{N})_3\text{PCl}^+ = 3\eta\text{Me}_2\text{N},\text{NMe}_2$
 $+ 3\eta\text{Me}_2\text{N},\text{Cl}$
 $= -57.9$ p.p.m.

This result is in good agreement with the observed chemical shift for $(\text{Me}_2\text{N})_3\text{PCl}^+$ ($\delta = -53.3$ p.p.m.)

10.6 The prediction of the chemical shift of $\text{Me}_3\text{PNMe}_2^+$ and $\text{MePNMe}_2\text{Cl}_2^+$

The chemical shifts of these phosphonium ions were predicted when the values of the pairwise parameters of the following substituents were known:

$\eta\text{Me},\text{Me}$, $\eta\text{Cl},\text{Me}$, $\eta\text{Cl},\text{Me}_2\text{N}$ and $\eta\text{Me},\text{NMe}_2$ as shown in Table 10.5.

Table 10.5

Calc.	Phosphonium ion	Observed δ p.p.m.	Reported δ p.p.m.	Reference	Substituent used in calculation	Pairwise parameter, p.p.m.
	Me_4P^+		-24	123	Me, Me	-4
	$\text{Me}_2\text{NPMe}_2\text{Cl}^+$	-103.3		113	$\text{Me}_2\text{N}, \text{Me}$	-21.04
	$\text{Me}-\text{PCl}_3^+$		-120		Cl, Me	-24.5
	$\text{Me}_2\text{NPCl}_3^+$	-61.3	-61.3	1,114	$\text{Me}_2\text{N}, \text{Cl}$	-5.93
-75.1	$\text{Me}_2\text{NPMe}_3^+$	-74.2				
-96.3	$\text{Me}_2\text{NPMeCl}_2^+$	-87.1				

The calculated chemical shift of $\text{Me}_3\text{PNMe}_2^+$ = $3n_{\text{Me}, \text{Me}} + 3n_{\text{Me}_2\text{N}, \text{Me}}$
= -75.1 p.p.m.

The value of the predicted chemical shift of $\text{Me}_3\text{PNMe}_2^+$ is in very good agreement with that of the observed chemical shift ($\delta = -74.2$ p.p.m.)

The calculated chemical shift of $\text{MePNMe}_2\text{Cl}_2^+$ =

$$2n_{\text{Cl}, \text{Me}} + 2n_{\text{Me}_2\text{N}, \text{Cl}} + n_{\text{Cl}, \text{Cl}} + n_{\text{Me}_2\text{N}, \text{Me}} = -96.3 \text{ p.p.m.}$$

The predicted chemical shift of $\text{MePNMe}_2\text{Cl}_2^+$ is not in very good agreement with the observed chemical shift. This could be attributed to the fact that the pairwise additivity rule assumes that the pairwise parameter value of substituents is the same regardless of the other atoms linked to the central nucleus, i.e. the pairwise parameter value of $n_{\text{Cl}, \text{Cl}}$ in PCl_4^+ is the same as that for $n_{\text{Cl}, \text{Cl}}$ in $\text{MePNMe}_2\text{Cl}_2^+$.

10.7 The calculation of the chemical shifts of $\text{PhPNMe}_2\text{Cl}_2^+$
and $\text{Ph}_2\text{PNMe}_2\text{Cl}^+$

To predict the chemical shifts of $\text{PhPNMe}_2\text{Cl}_2^+$ and $\text{Ph}_2\text{PNMe}_2\text{Cl}^+$ the values of the parameters of the following substituents were needed, $\eta_{\text{Cl,Cl}}$, $\eta_{\text{Ph,Ph}}$, $\eta_{\text{Ph,Cl}}$, $\eta_{\text{Cl,NMe}_2}$ and $\eta_{\text{Ph,NMe}_2}$. These values are deduced from the chemical shifts of the phosphonium ions listed in Table 10.6.

Table 10.6

<i>Calc.</i>	Phosphonium ion	Observed δ p.p.m.	Reported δ p.p.m.	Reference	Substituent used in calculation	Pairwise parameter, p.p.m.
	PCl_4^+	-87.1	-87	122	Cl,Cl	-14.5
	PhPCl_3^+	-103.1	-100	113	Ph,Cl	-18.83
	$\text{Me}_2\text{NPCl}_3^+$	-61.3	-61.3	1,114	$\text{Me}_2\text{N,Cl}$	-5.93
	$\text{Me}_2\text{NPPh}_3^+$	-46.7			Ph, NMe_2	-12.1
- 76.1	$\text{PhPNMe}_2\text{Cl}_2^+$	-74.9				
- 71.3	$\text{Ph}_2\text{PNMe}_2\text{Cl}^+$	-70.9				

The value of $\eta_{\text{Ph,Ph}}$ was deduced from the chemical shift of Ph_4P^+ (Table 10.3).

The predicted chemical shift for $\text{PhPNMe}_2\text{Cl}_2^+ = 2 \eta_{\text{Cl,Ph}} + 2\eta_{\text{Cl,NMe}_2} + \eta_{\text{Cl,Cl}} + \eta_{\text{Ph,NMe}_2} = -76.12$ p.p.m.

The predicted chemical shift for $\text{Ph}_2\text{PNMe}_2\text{Cl}^+ = 2\eta_{\text{Ph,Cl}} + 2\eta_{\text{Ph,NMe}_2} + \eta_{\text{Ph,Ph}} + \eta_{\text{NMe}_2,\text{Cl}} = -71.26$ p.p.m.

The predicted and the observed chemical shifts of the two ions are in good agreement.

10.8 Conclusion

From the work described in this chapter it is possible to point out that the pairwise additivity rule is a good method to predict the chemical shifts of the phosphonium ions, which helps in confirming their formation. The greatest error found occurred for the $\text{Me}_2\text{NPMcCl}_2^+$ ion (Section 10.6) and was only slightly over 10%.

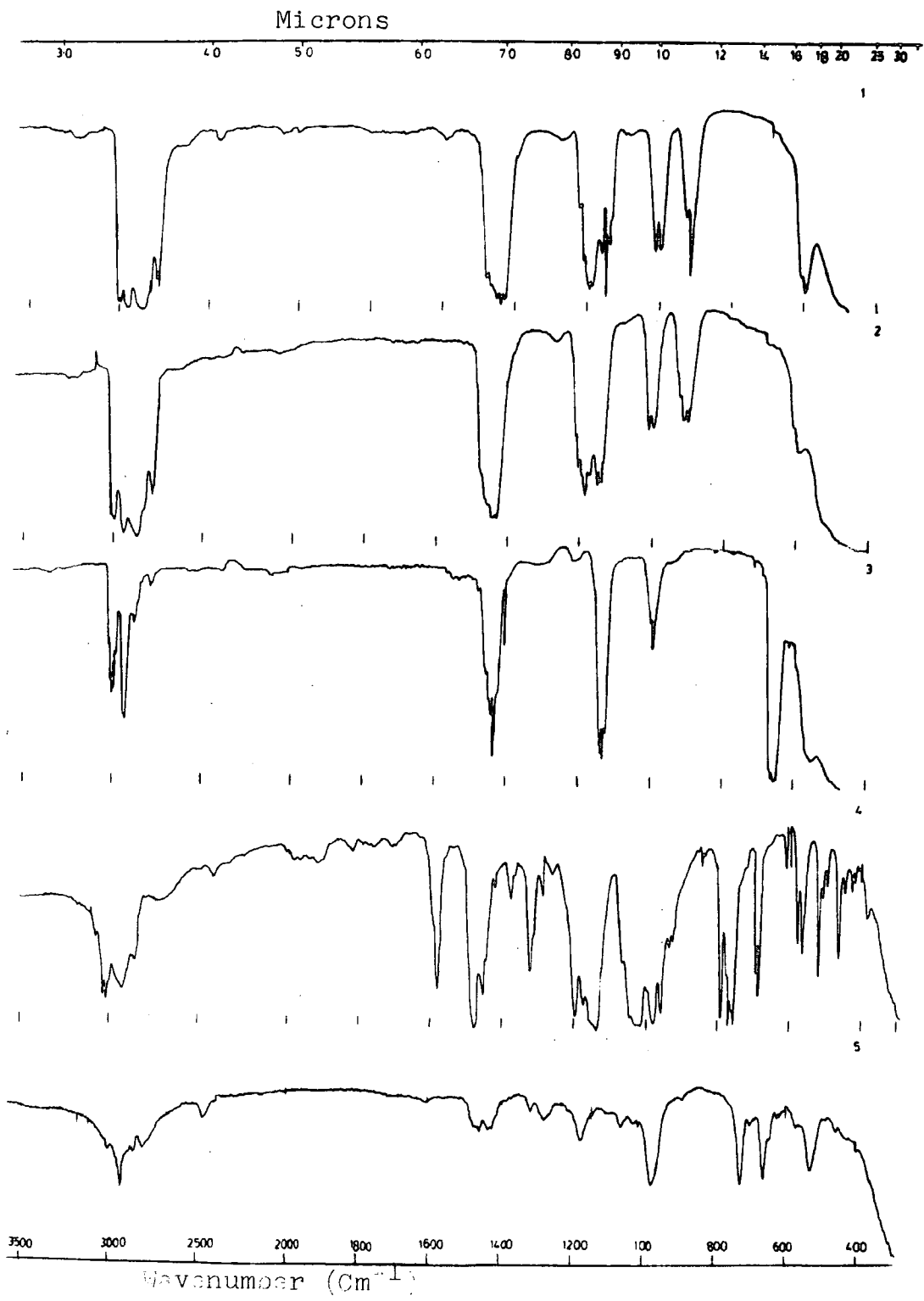

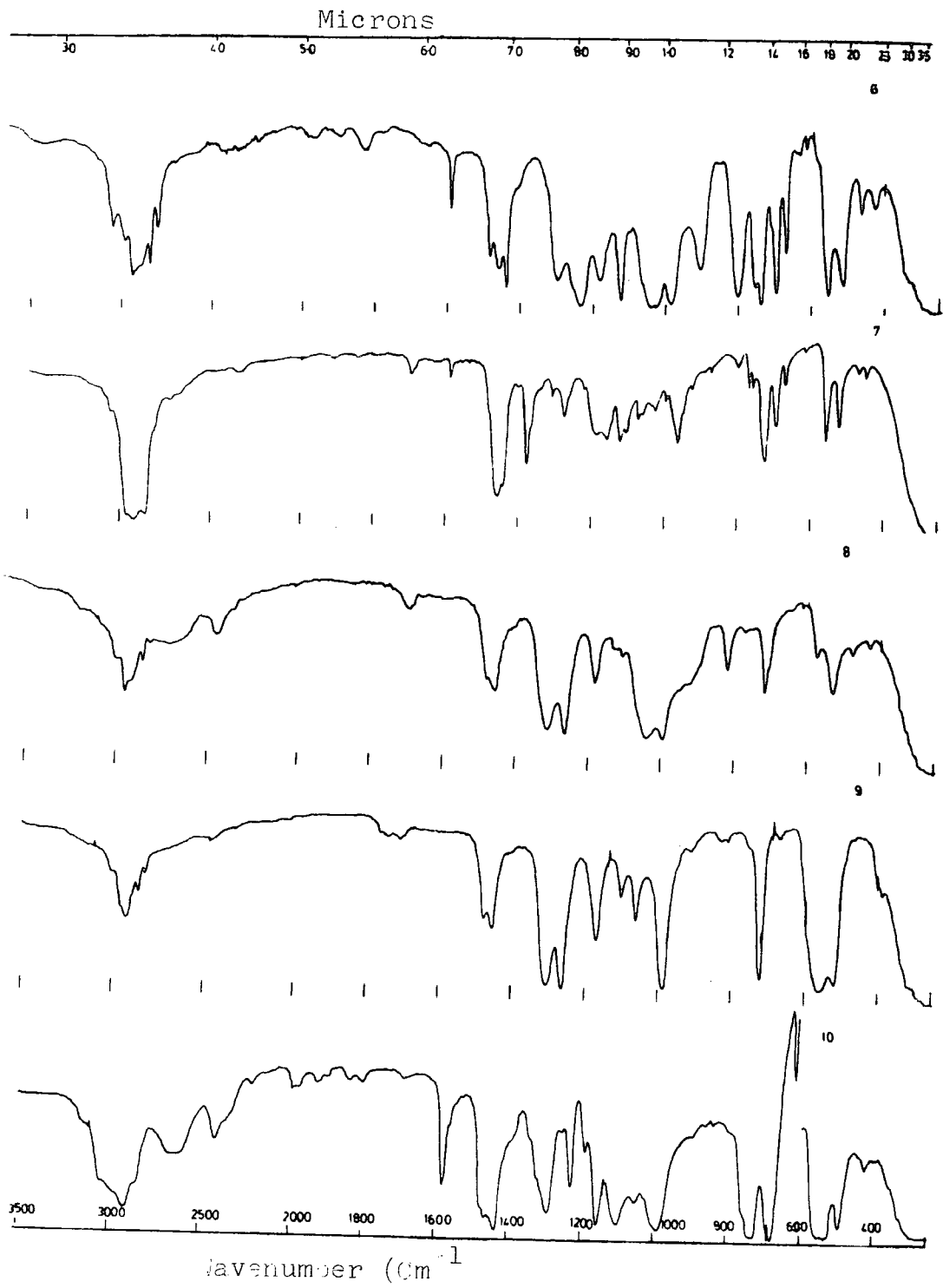

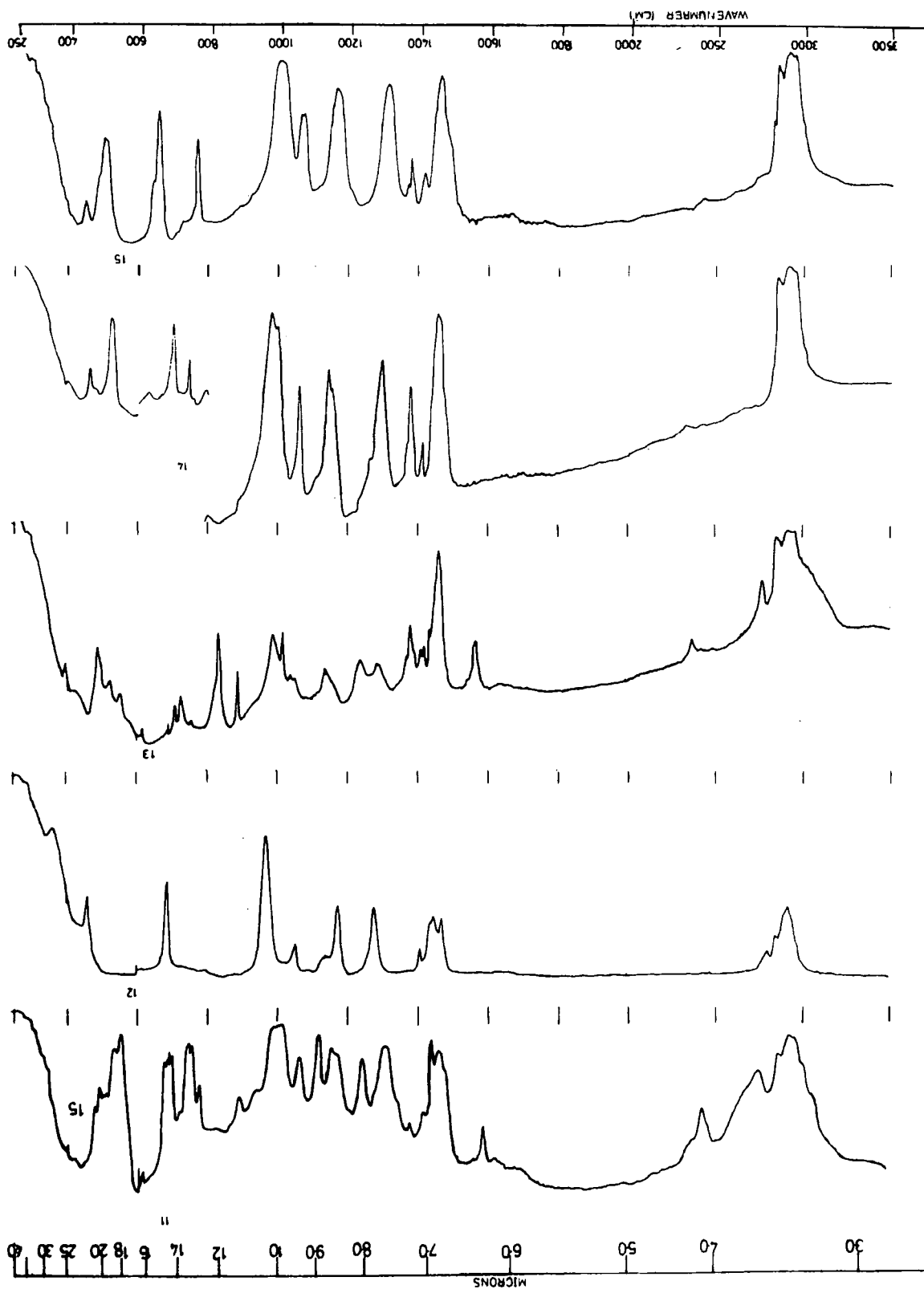

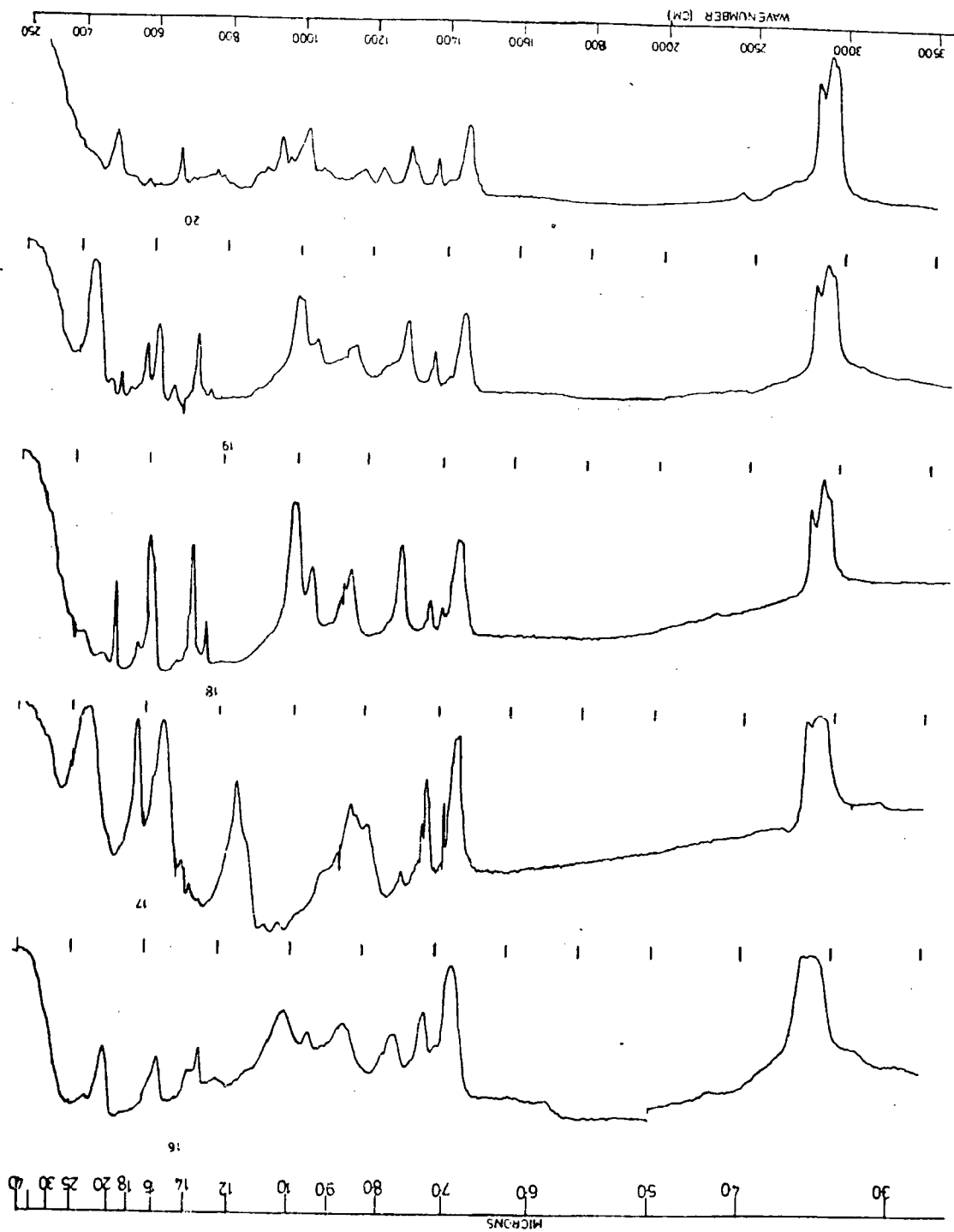

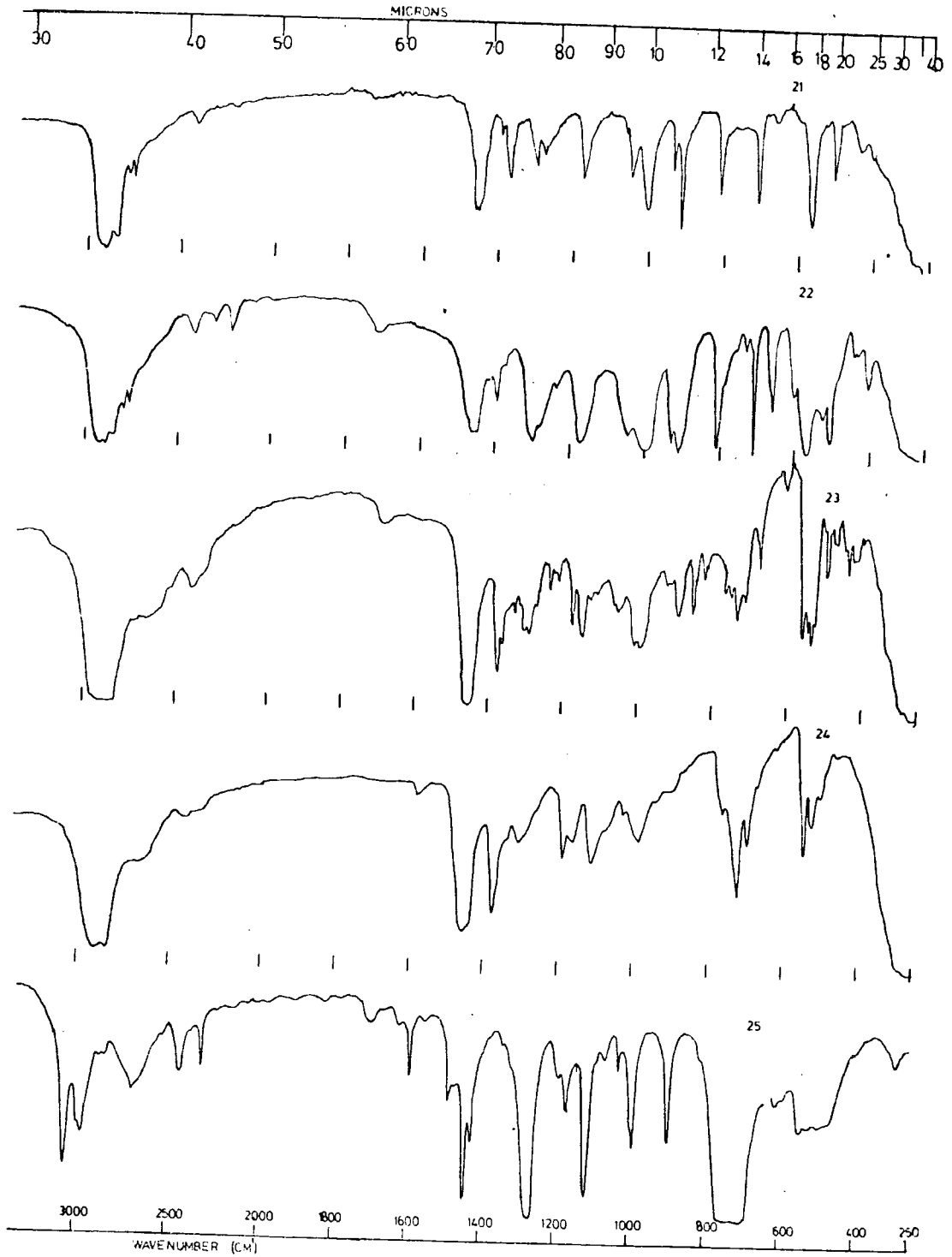

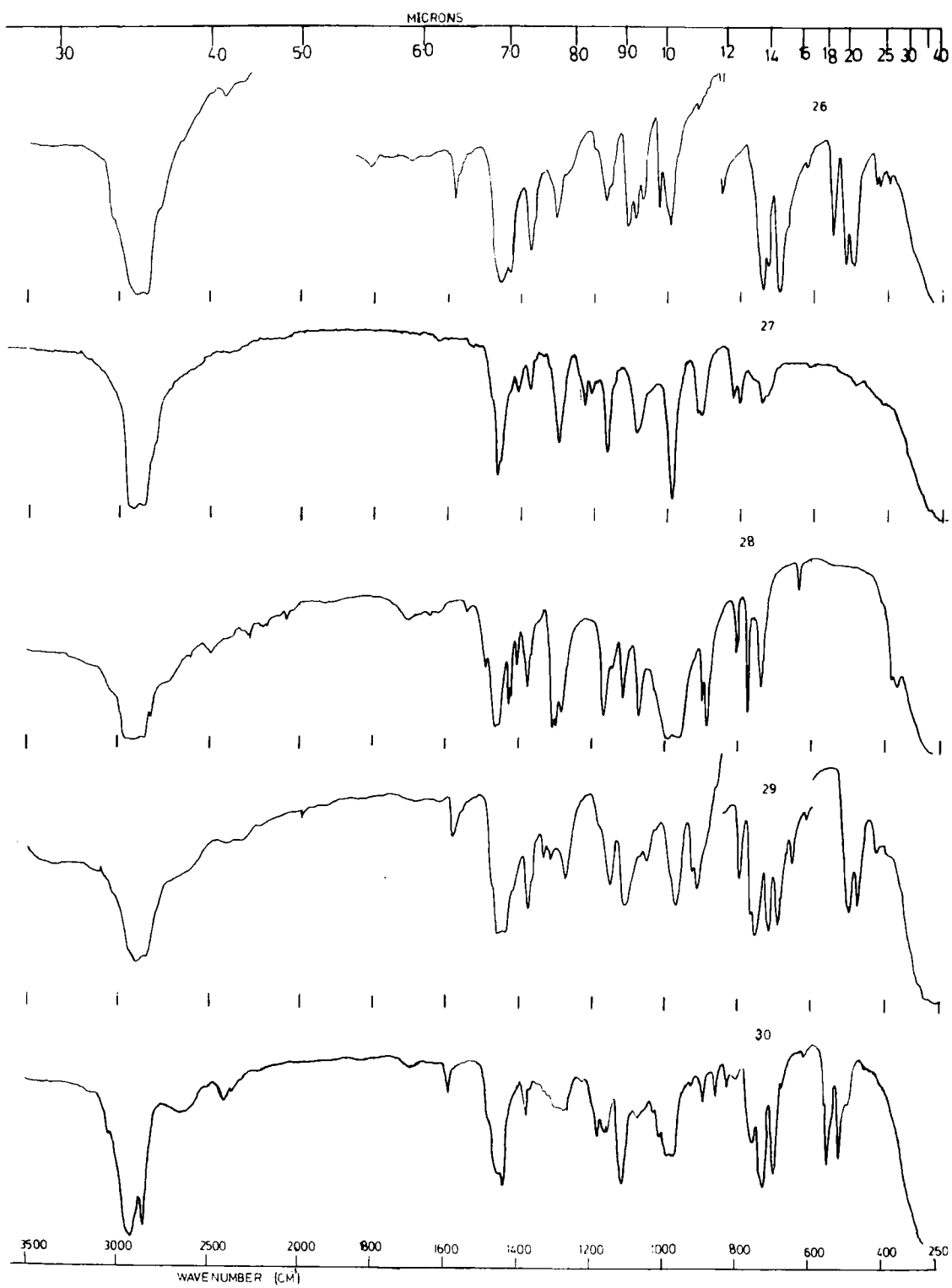

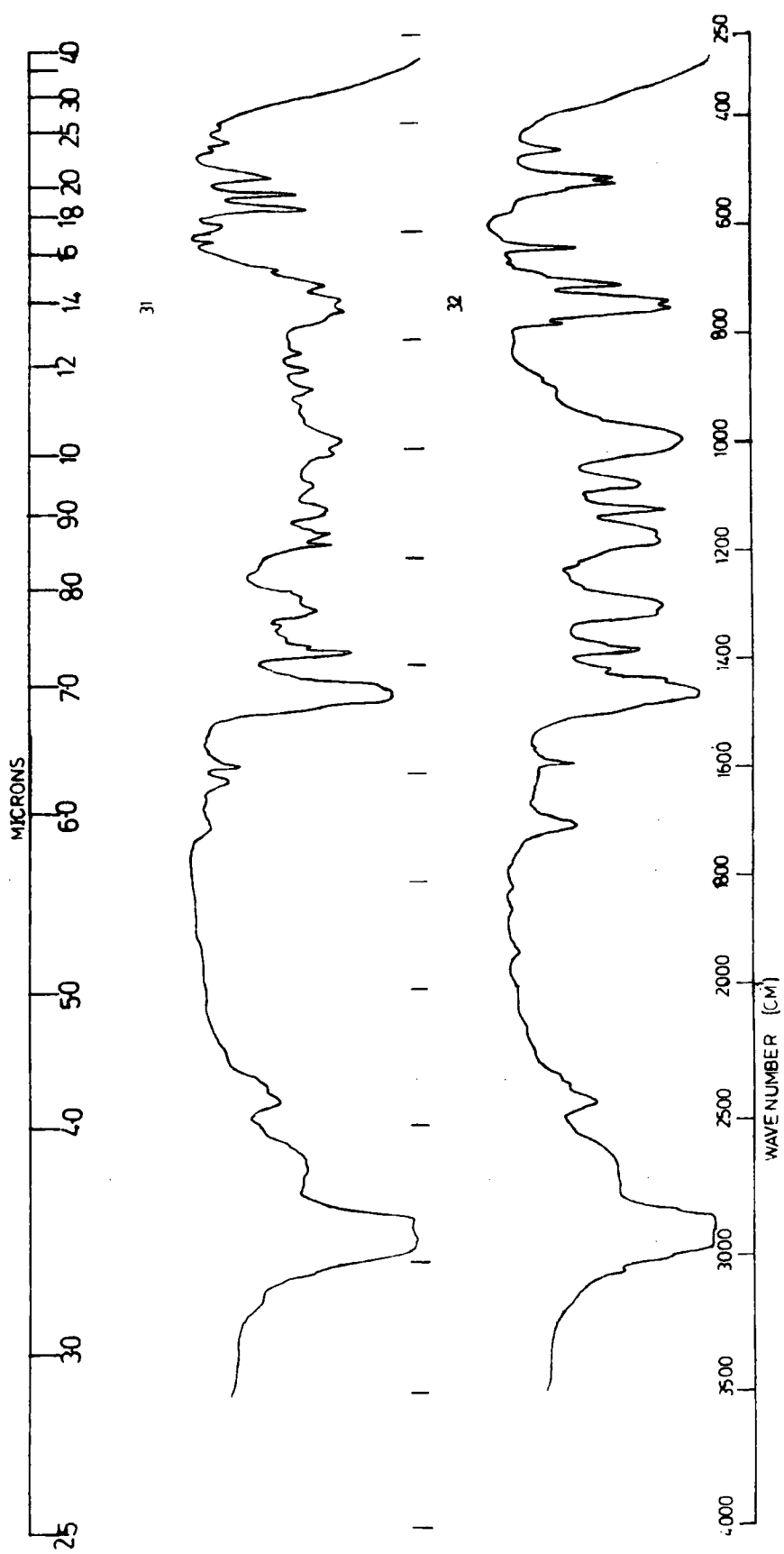

33

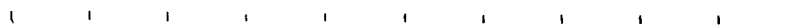
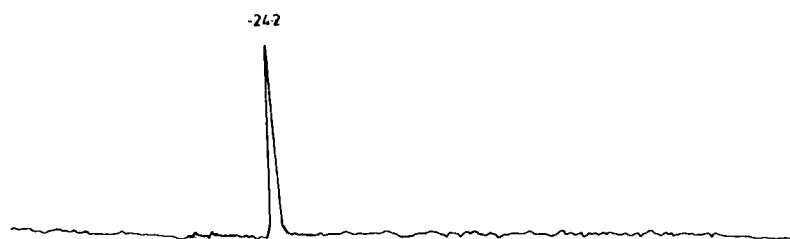

34

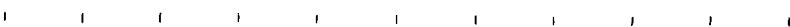
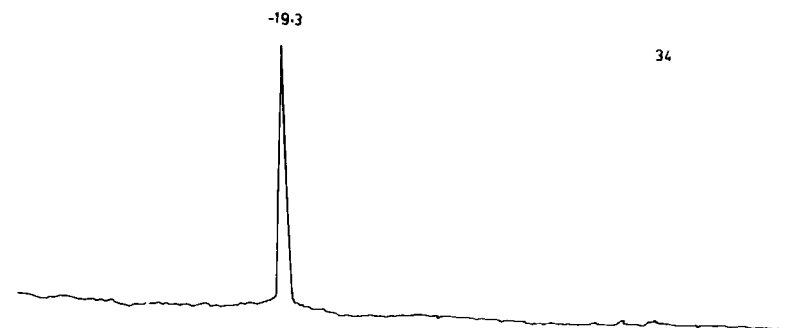

35

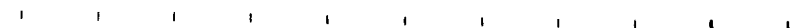
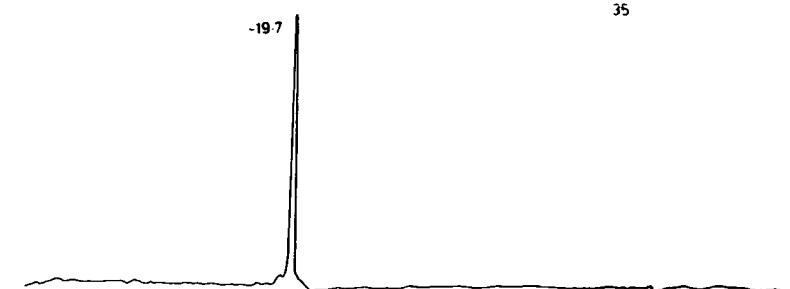

36

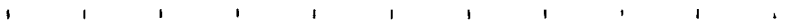
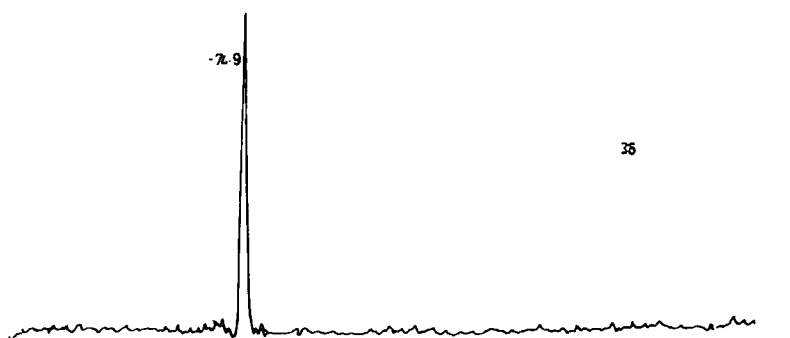

37

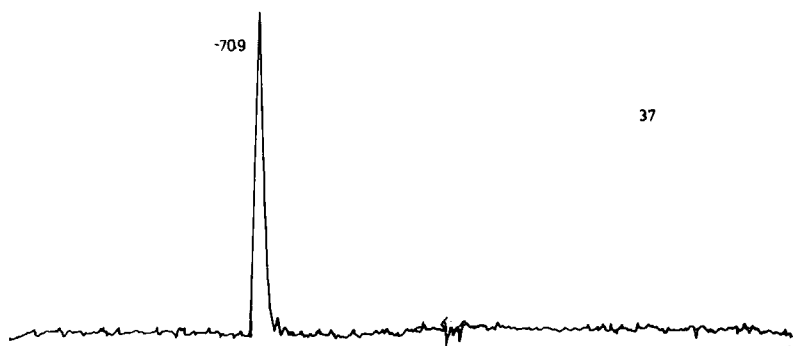

-298.5 PPM

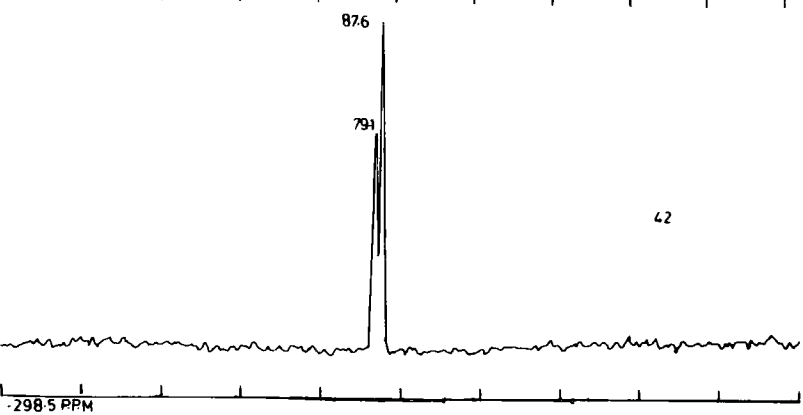
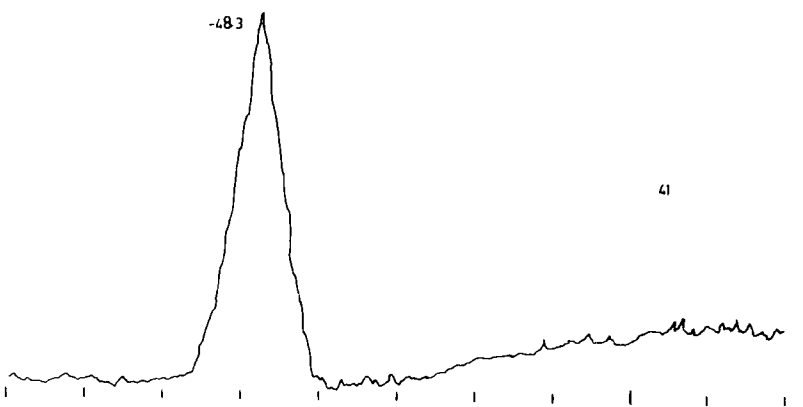
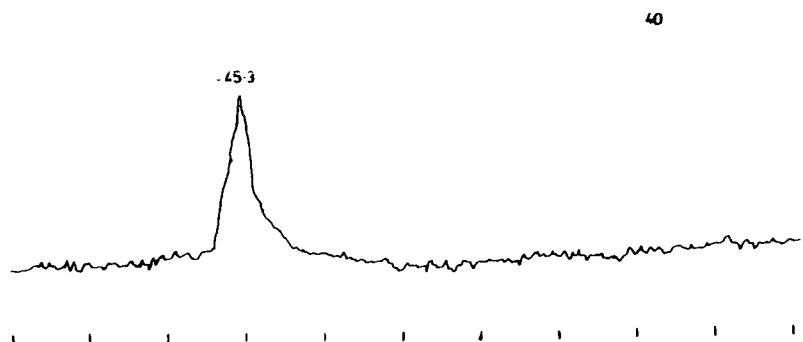
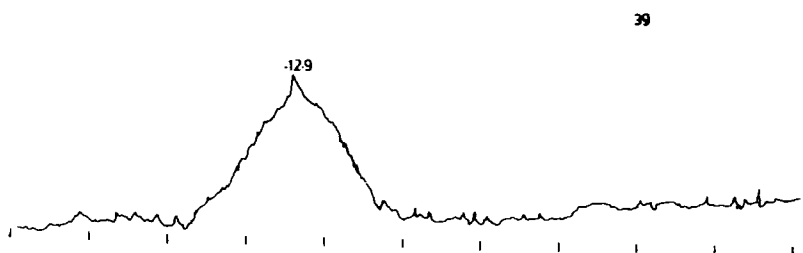
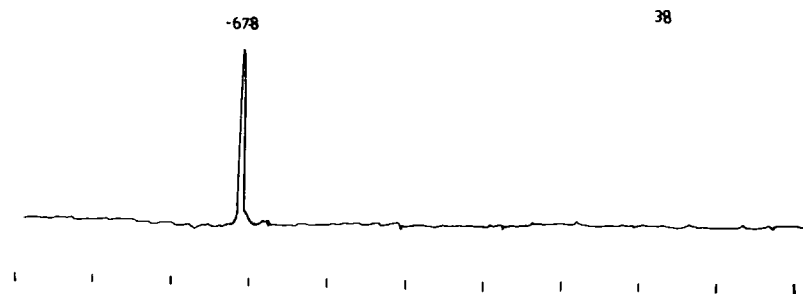

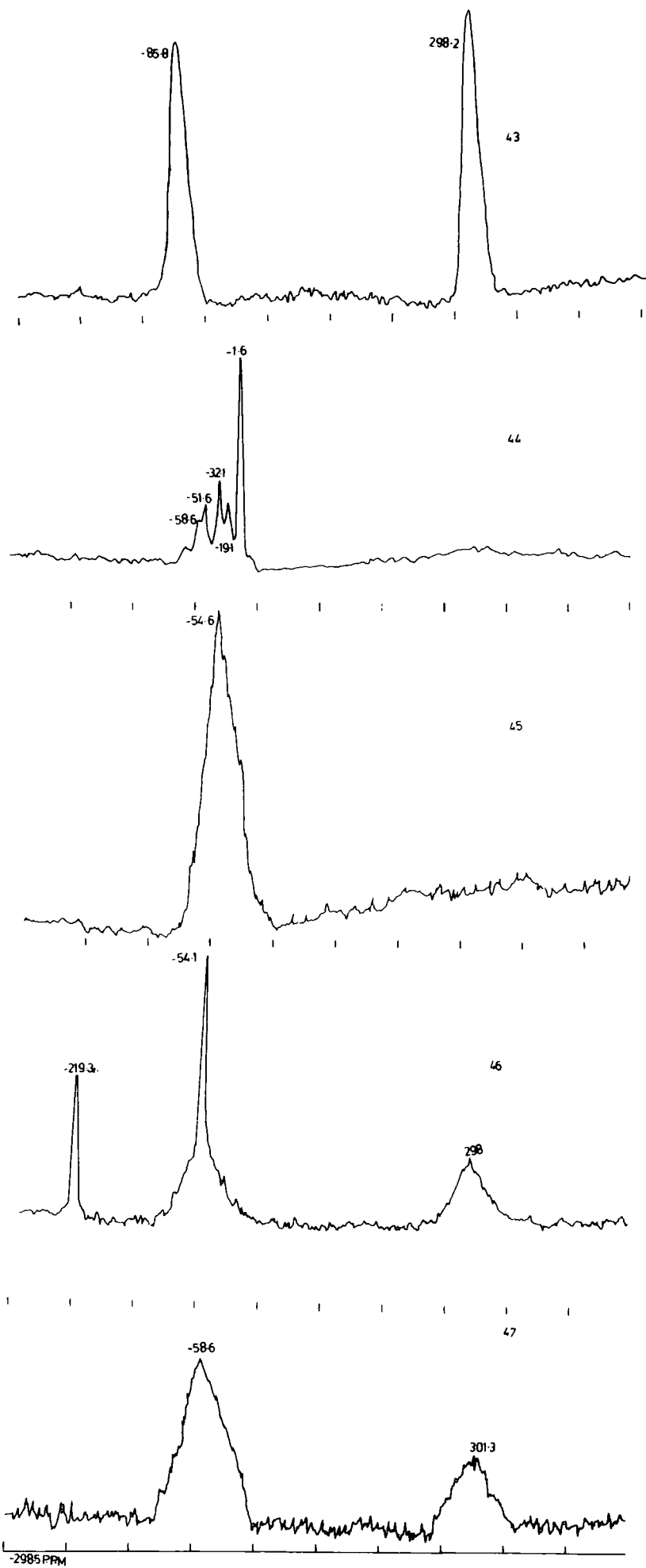

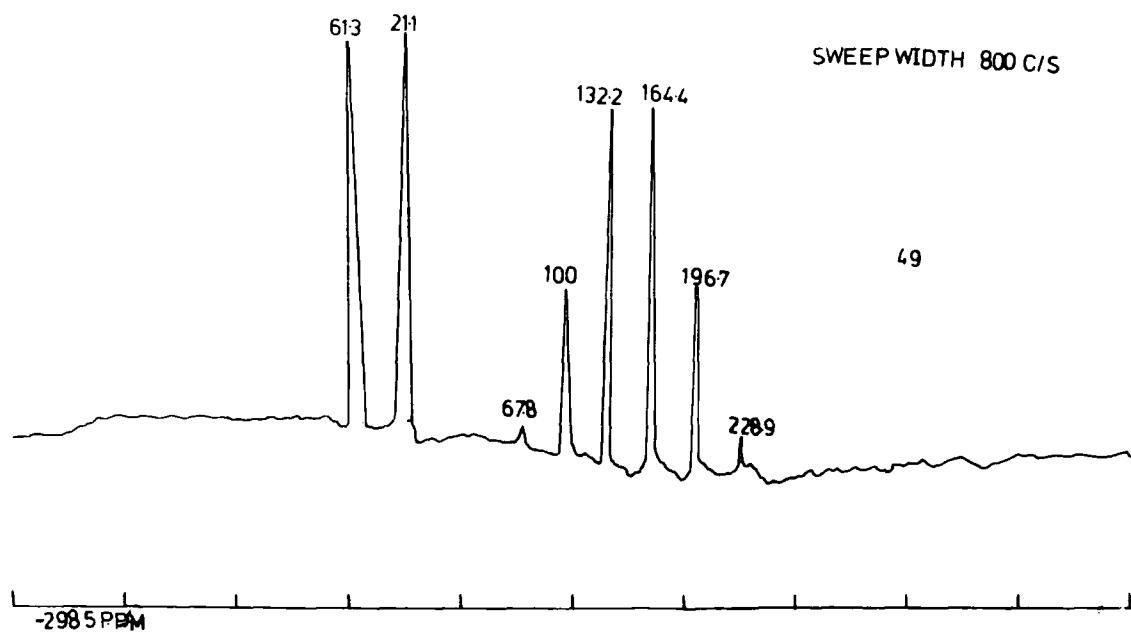
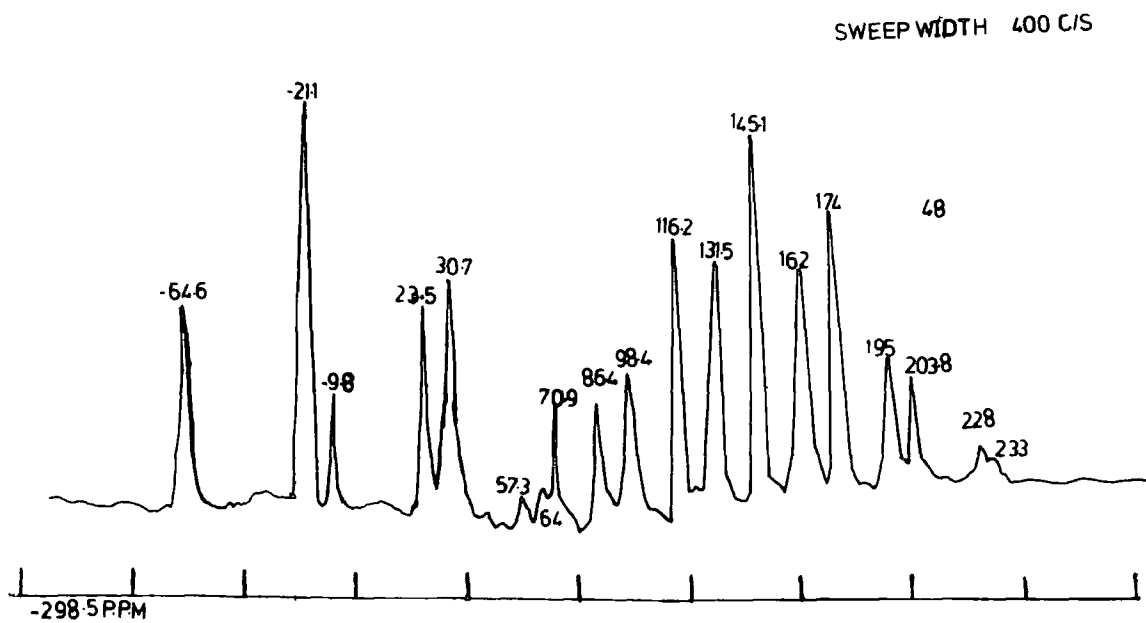

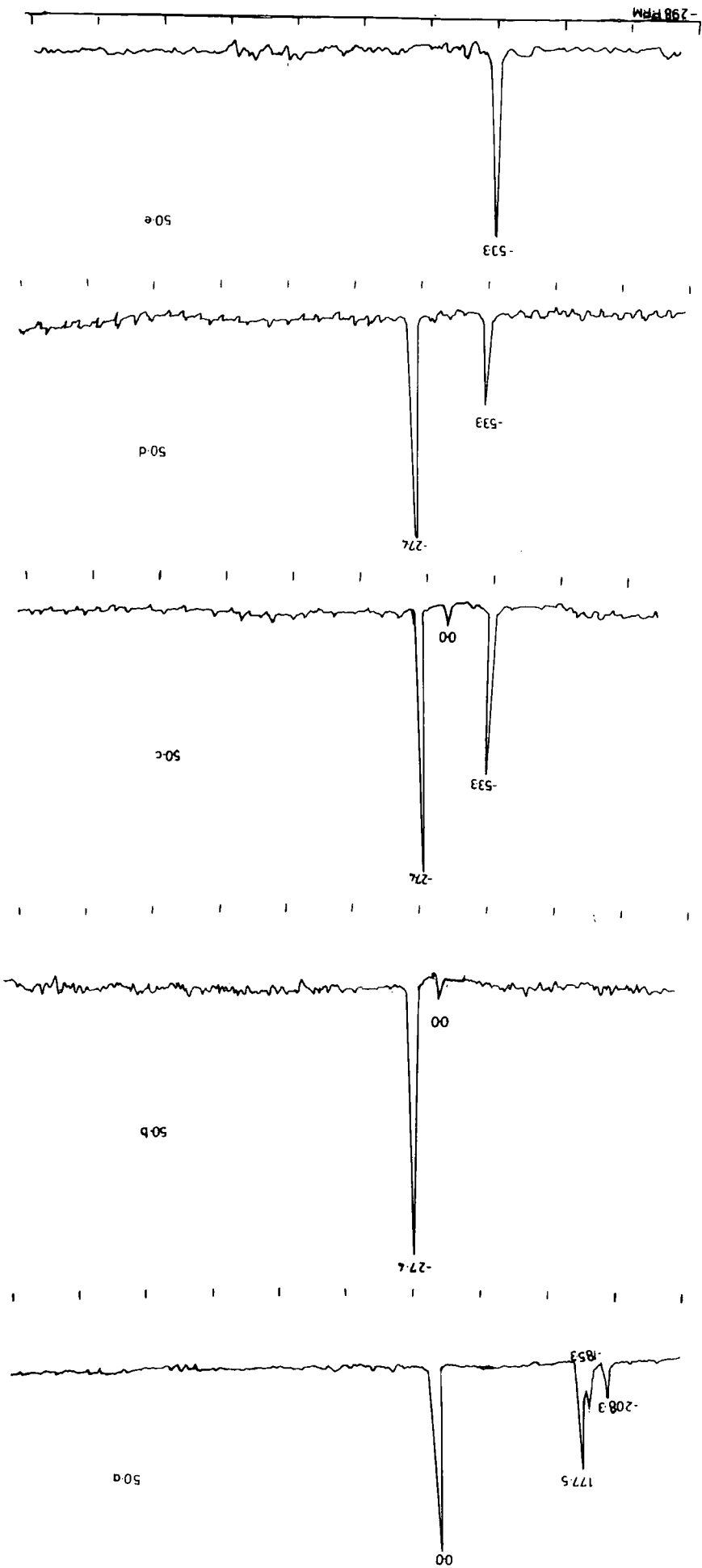

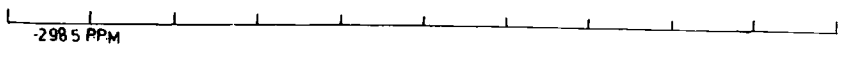
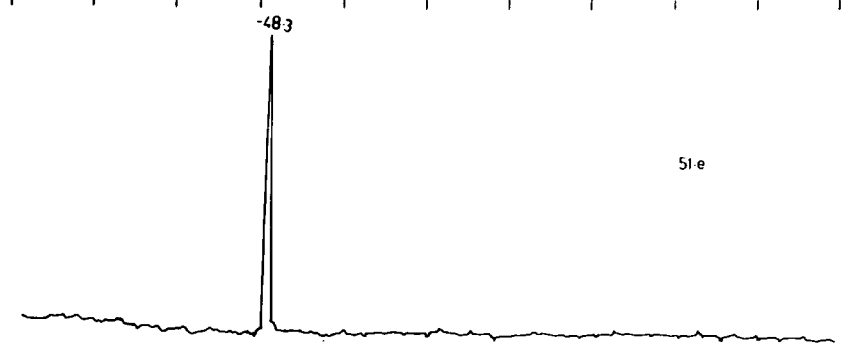
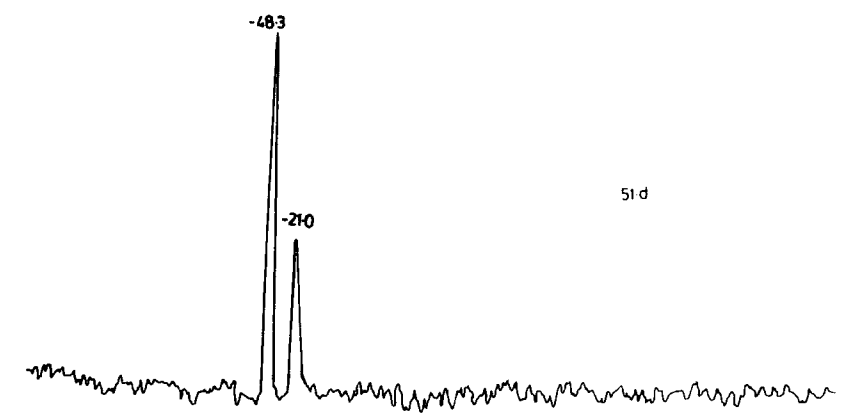
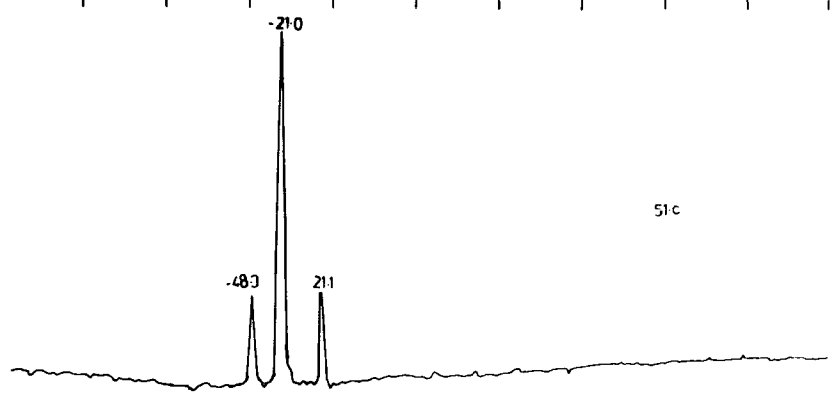
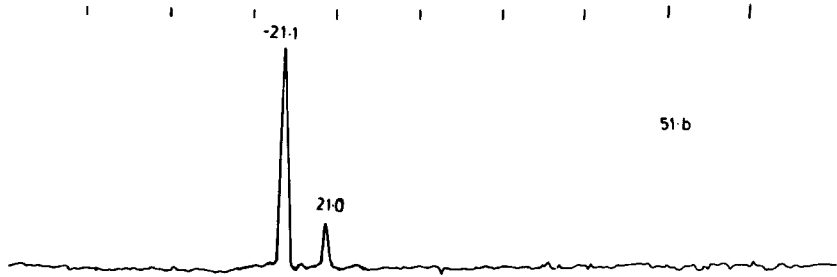
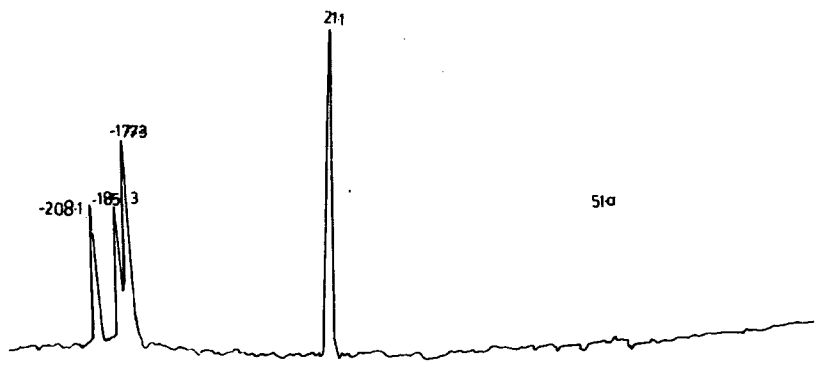

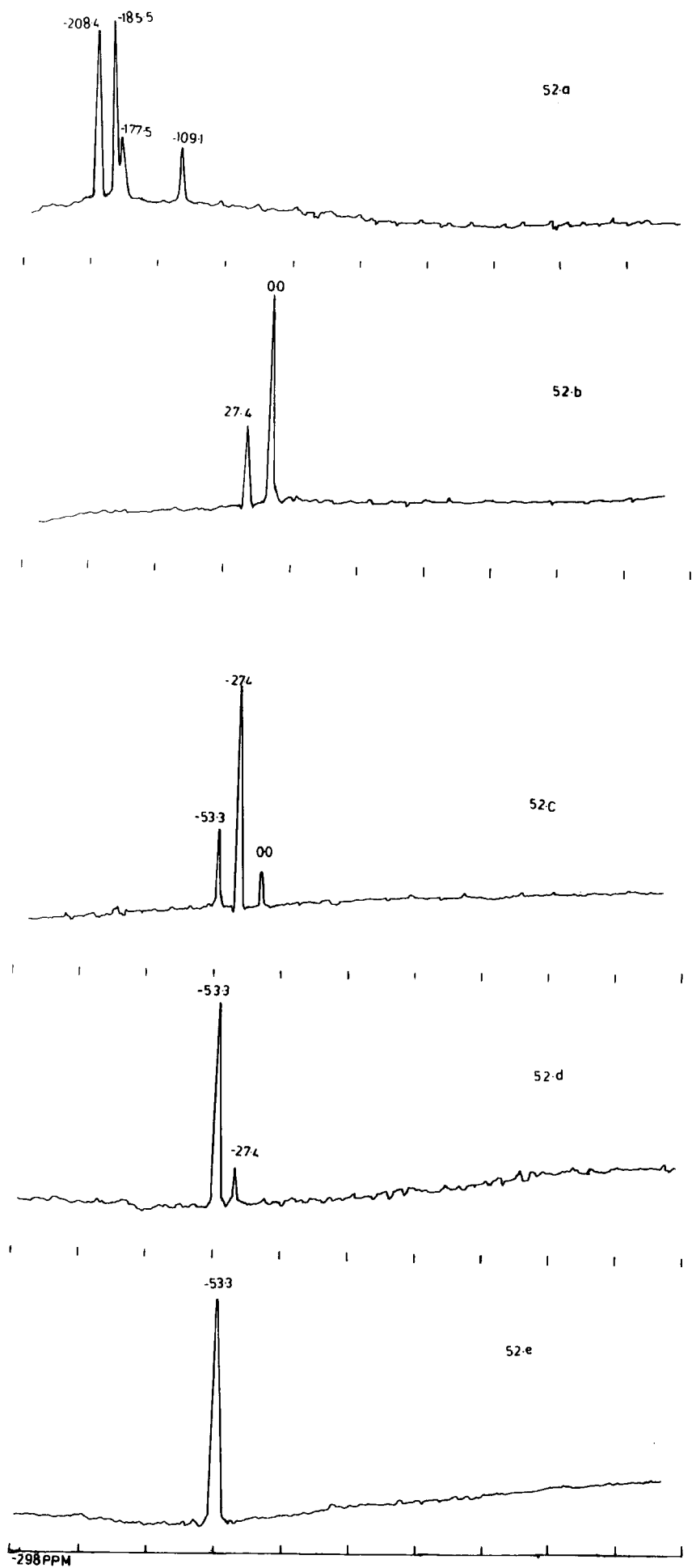

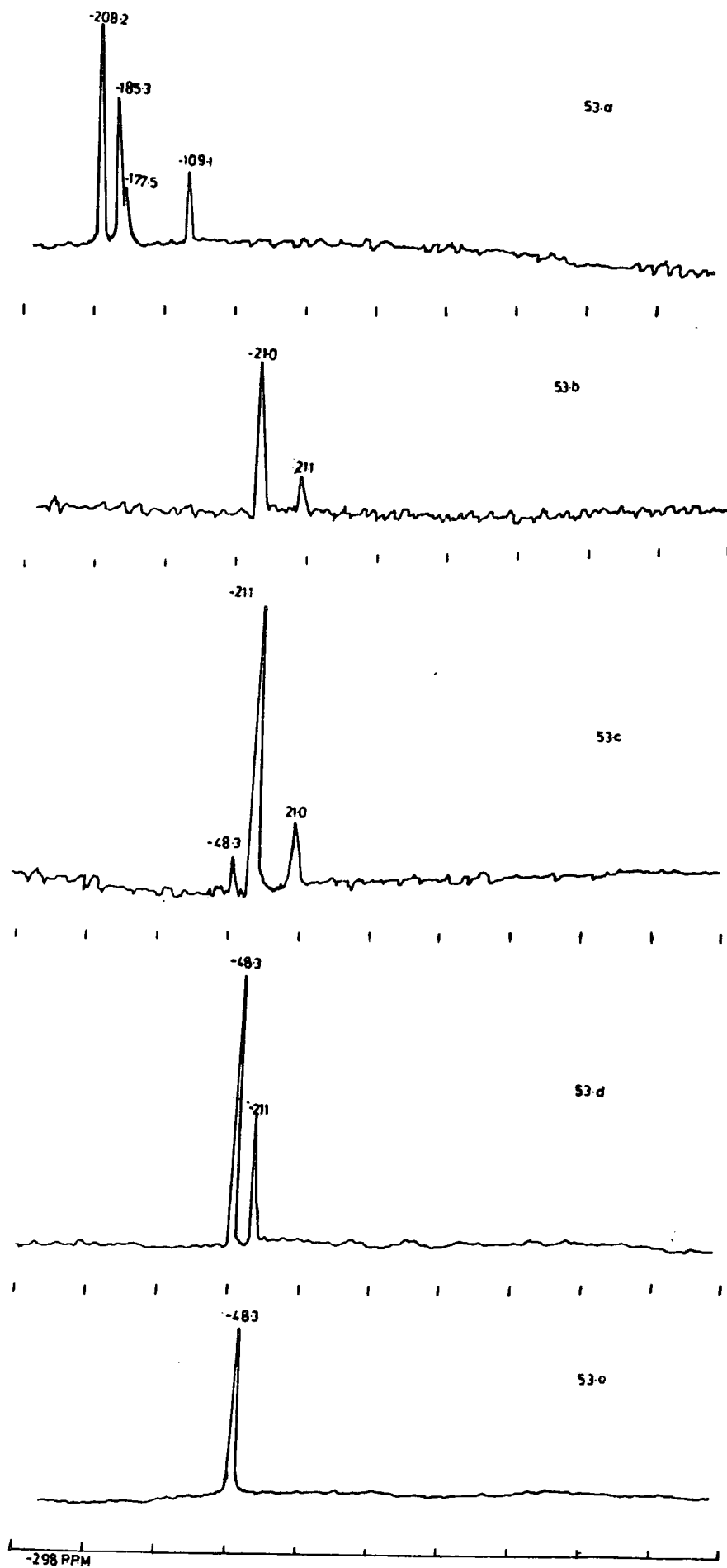

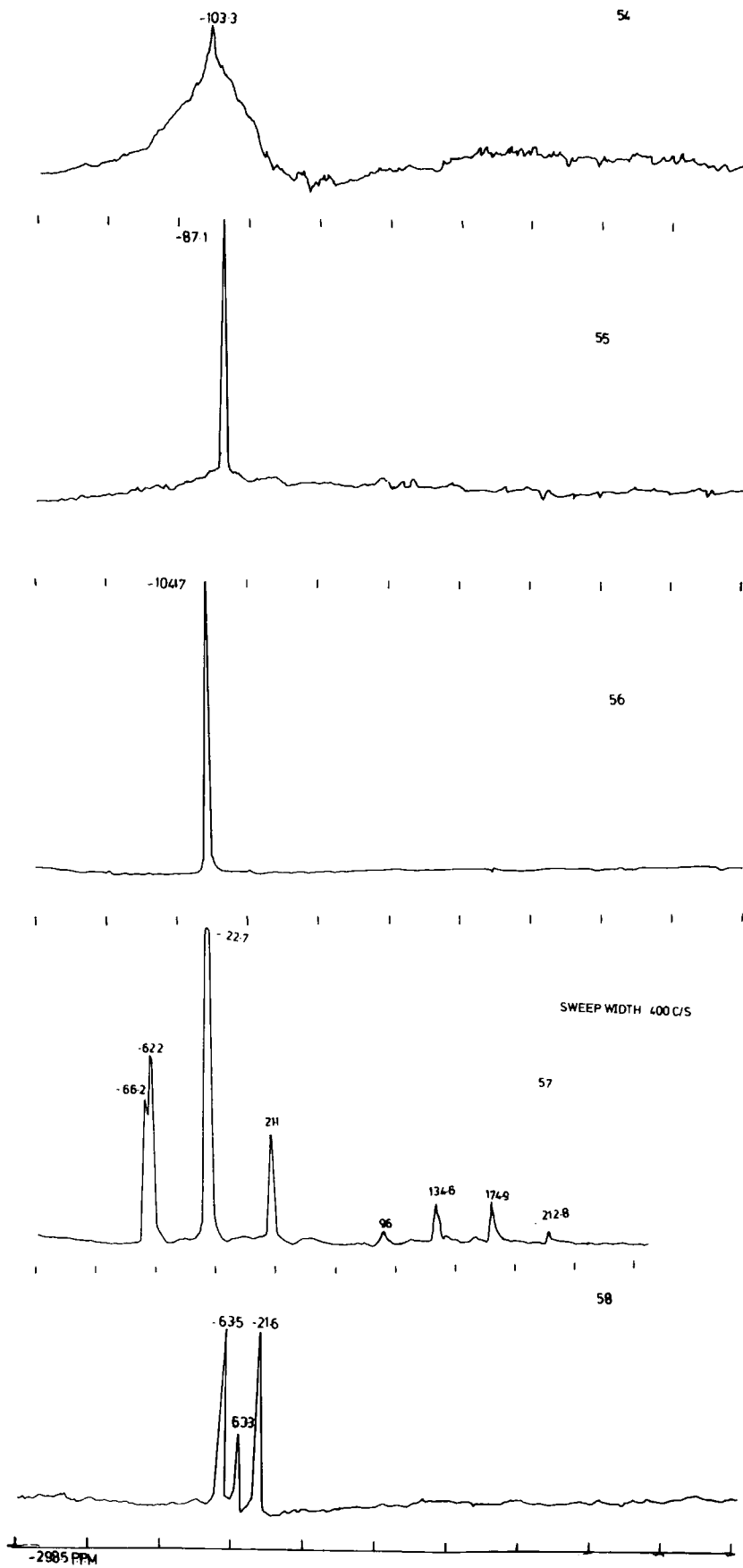

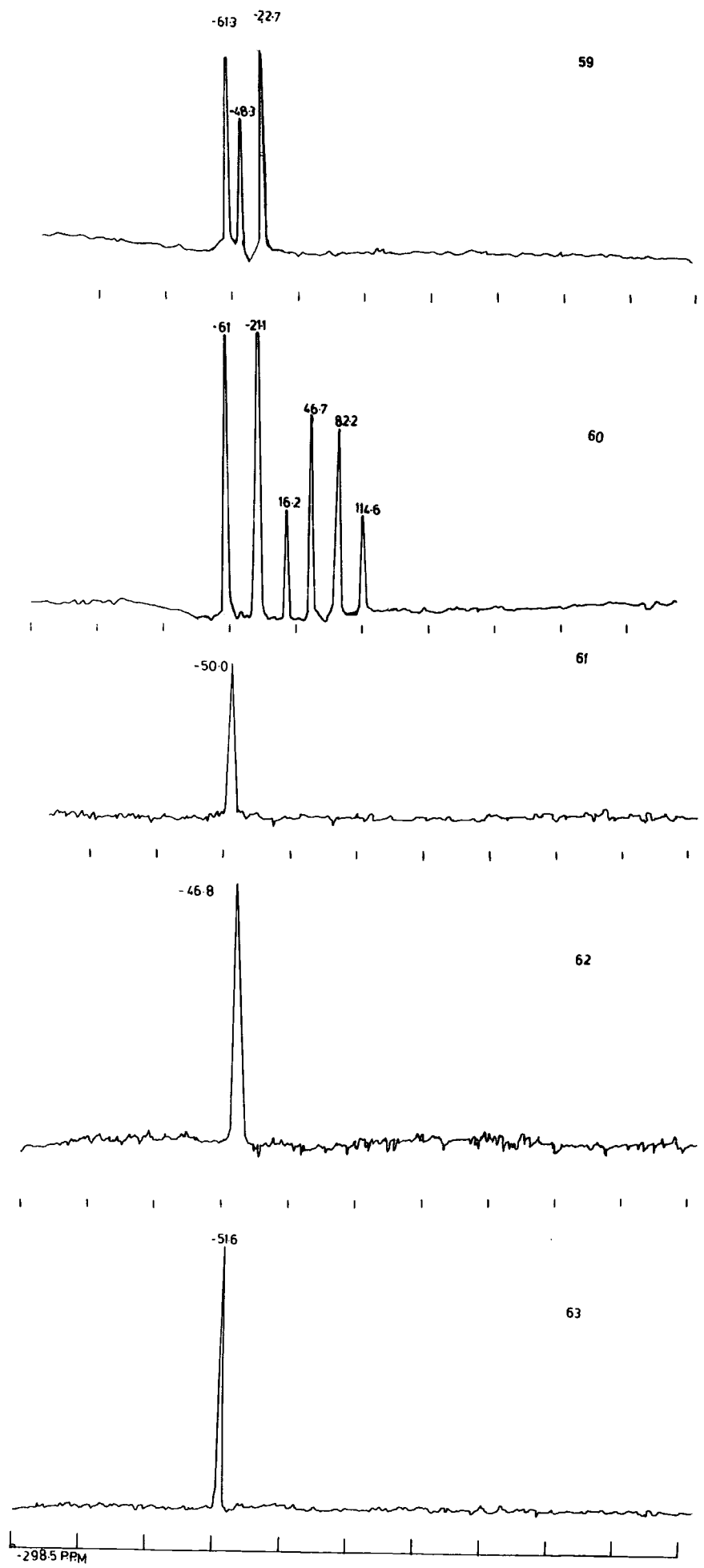

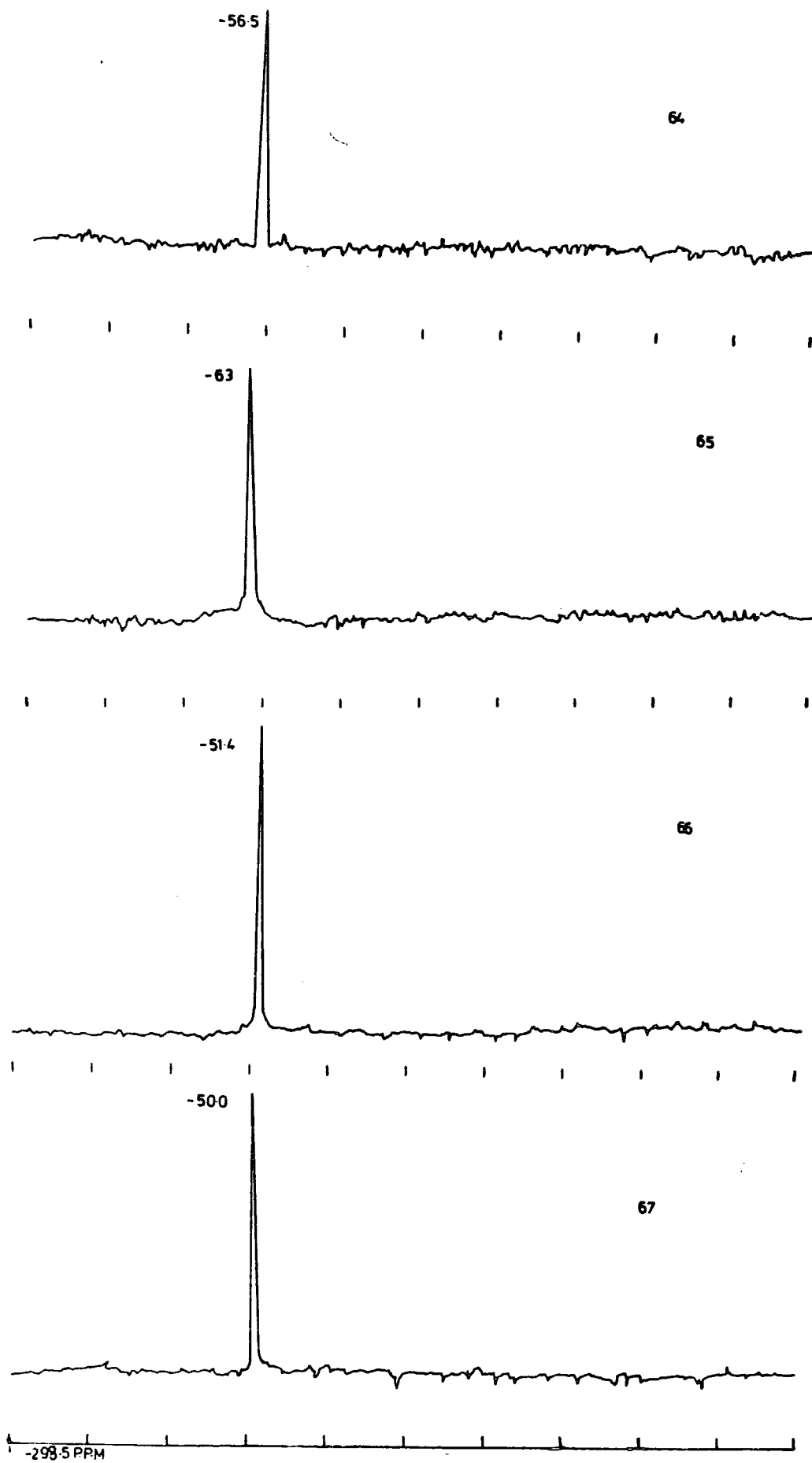

APPENDIX IIIDEPARTMENTAL COLLOQUIA AND FIRST YEAR INDUCTION COURSE
FOR POSTGRADUATES

The Board of Studies in Chemistry requires that each postgraduate research thesis contains an appendix listing

(a) all research colloquia, research seminars and lectures arranged by the Department of Chemistry during the period of the writer's residence as a postgraduate student;

(b) all research conferences attended and papers read out by the writer of the thesis, during the period when the research for the thesis was carried out; and

(c) details of the first-year induction course.

Events in (a) which were attended are marked *

Research Colloquia, Seminars and LecturesI. University of Durham Chemistry ColloquiaAcademic Year 1977-78

19 Oct. Dr. B. Heyn (U. of Jena, D.D.R.), "Sigma-organo molybdenum complexes as alkene polymerisation catalysts".

* 27 Oct. Professor R.A. Filler (Illinois Institute of Technology, U.S.A.), "Reactions of organic compounds with xenon fluorides".

* 2 Nov. Dr. N. Boden (U. of Leeds), "N.m.r. spin-echo experiments for studying structure and dynamical properties of materials containing interacting spin Y_2 -pairs".

9 Nov. Dr. A.R. Butler (U. of St. Andrews), "Why I lost faith in linear free energy relationships".

7 Dec. Dr. P.A. Madden (U. of Cambridge), "Raman studies of molecular motions in liquids".

☆ 14 Dec. Dr. R.O. Gould (U. of Edinburgh), "Crystallography to the rescue in ruthenium chemistry".

25 Jan. Dr. G. Richards (U. of Oxford), "Quantum Pharmacology".

1 Feb. Professor K.J. Ivin (Queens U. Belfast), "The olefin metathesis reaction, mechanism of ring opening polymerisation of cycloalkenes".

☆ 3 Feb. Dr. A. Hartog (Free U., Amsterdam), "Surprising recent studies in organomagnesium chemistry".

☆ 22 Feb. Professor J.D. Birchall (Mond Division, I.C.I.), "Silicon in the biosphere".

1 Mar. Dr. A. Williams (U. of Kent), "Acyl group transfer reactions".

☆ 3 Mar. Dr. G. van Koten (U. of Amsterdam), "Structure and reactivity of aryl-copper cluster compounds".

15 Mar. Professor G. Scott (U. of Aston), "Fashioning plastics to match the environment".

☆ 22 Mar. Professor H. Vahrenkamp (U. of Freiburg, Germany), "Metal-metal bonds in organometallic complexes".

19 Apr. Dr. M. Barber (UMIST), "Secondary ion mass spectra of surfaces and adsorbed species".

16 May Dr. P. Ferguson (C.N.R.S., Grenoble), "Surface plasma waves and adsorbed species on metals".

18 May Professor M. Gordon (U. of Essex), "Three critical points in polymer chemistry".

22 May Professor D. Tuck (U. of Windsor, Ontario), "Electrochemical synthesis of inorganic and organo-metallic compounds".

* 24 & 25 May Professor P. von Schleyer (U. of Erlangen, Nurnberg),

I "Planar tetra-coordinate methanes, perpendicular ethenes, and planar allenes".

II "Aromaticity in three dimensions".

III "Non-classical carbo-cations".

21 June Dr. S.K. Tyrlik (Acad. of Sci., Warsaw), "Dimethylglyoxime cobalt complexes - catalytic black boxes".

23 June Professor G. Mateescu (Case Western Reserve U., Ohio), "A concerted spectroscopy approach to the characterisation of ion and ion-pairs: facts, plans, and dreams".

8 Sept. Dr. A. Diaz (I.B.M., San Jose, California), "Chemical behaviour of electrode surface bonded molecules".

15 Sept. Professor W. Siebert (Marburg, W. Germany), "Boron heterocycles".

* 22 Sept. Professor T. Fehlner (Notre Dame, U.S.A.), "Ferraboranes: synthesis and photochemistry".

Academic Year 1978-79

12 Dec. Professor C.J.M. Stirling (U. of Bangor), "Parting is such sweet sorrow - the leaving group in organic chemistry".

31 Jan. Professor P.D.B. de la Mare (U. of Auckland, New Zealand), "Some pathways leading to electrophilic substitution".

14 Feb. Professor B. Dannel (U. of British Columbia), "The application of n.m.r. to the study of motions of molecules in solids".

14 Mar. Dr. J.C. Walton (U. of St. Andrews), "Pentadienyl radicals".

28 Mar. Dr. A. Reiser (Kodak Ltd.), "Polymer photography and the mechanism of cross-link formation in solid polymer matrices".

* 25 Apr. Dr. C.R. Patrick (U. of Birmingham), "Chlorofluorocarbons and stratospheric ozone: an appraisal of the environmental problem".

1 May Dr. G. Wyman (European Research Office, U.S. Army), "Excited state chemistry of indigoid dyes".

* 2 May Dr. J.D. Hobson (U. of Birmingham), "Nitrogen-centred reactive intermediates".

8 May Professor A. Schmidpeter (Inst. of Inorg. Chem., Munich U.), "Five-membered Phosphorous heterocycles containing dicoordinate phosphorous".

* 9 May Professor G. Maier (Lahn Giessen U.), "Tetra-tert-butyltetrahedrane".

* 9 May Dr. A.J. Kirkby (U. of Cambridge), "Structure and reactivity in intramolecular and enzymic catalysis".

* 16 May Dr. J.F. Nixon (U. of Sussex), "Some recent developments in platinum-phosphine complexes".

23 May Dr. B. Wakefield (U. of Salford), "Electron transfer in reaction of metals and organometallic compounds with polychloropyridine derivatives".

13 June Professor I. Ugi (U. of Munich), "Synthetic uses of super nucleophiles".

+ 25 Sept. Professor R. Soulen (Southwestern U., Texas), "Applications of HSAB theory to vinylic halogen substitution reactions and a few copper coupling reactions".

Academic Year 1979-80

* 21 Nov. Dr. J. Muller (U. of Bergen), "Photochemical reactions of ammonia".

28 Nov. Dr. B. Cox (U. of Stirling), "Macrobicyclic cryptate complexes: dynamics and selectivity".

5 Dec. Dr. G.C. Eastmand (U. of Liverpool), "Synthesis and properties of some multicomponent polymers".

12 Dec. Dr. C.I. Ratcliffe, "Rotor motions in solids".

* 18 Dec. Dr. K.E. Newman (U. of Lausanne), "High pressure multinuclear n.m.r. in the elucidation of mechanism of simple fast inorganic reactions".

* 30 Jan. Dr. M.J. Barrow (U. of Edinburgh), "The structures of some simple inorganic compounds of silicon and germanium - pointers to structural trends in group 4".

6 Feb. Dr. J.M.E. Quirke (U. of Durham), "Degradation of chlorophyll - a in sediments".

* 23 Apr. B. Grievson B.Sc. (U. of Durham), "Halogen radio-pharmaceuticals".

14 May Dr. R. Hutton (Waters Associates), "Recent developments in multi-milligram and multi-gram scale preparative high performance liquid chromatography".

21 May Dr. T.W. Bentley (U. of Swansea), "Medium and structural effects on solvolytic reactions".

* 10 July Professor D. Des Marteau (U. of Heidelberg), "New developments in organonitrogen fluorine chemistry".

2. Durham University Chemical Society

Academic Year 1977-78

13 Oct. Dr. J.C. Young and Mr. A.J.S. Williams (U. of Aberystwyth), "Experiments and considerations touching colour".

* 20 Oct. Dr. R.L. Williams (Metropolitan Police Forensic Science Dept.), "Science and crime".

3 Nov. Dr. G.W. Gray (U. of Hull), "Liquid crystals - their origins and applications".

24 Nov. Mr. G. Russel (Alcan), "Designing for social acceptability".

✧ 1 Dec. Dr. B.F.G. Johnson (U. of Cambridge), "Chemistry of binary metal carbonyls".

2 Feb. Professor R.A. Raphael (U. of Cambridge), "Bizarre reactions of acetylenic compounds".

16 Feb. Professor G.W.A. Fowles (U. of Reading), "Home winemaking".

9 Mar. Professor H. Suschitzky (U. of Salford), "Fruitful fissions of benzofuroxans".

* 4 May Professor J. Chatt (U. of Sussex), "Reactions of coordinated dinitrogen".

9 May Professor G.A. Olah (Case Western Reserve U., Ohio), "Electrophilic reactions of hydrocarbons".

Academic Year 1978-79

10 Oct. Professor H.C. Brown (U. of Purdue), "The tool of increasing electron demand in the study of cationic processes".

✧ 19 Oct. Mr. F.C. Shenton (Public Analyst, Co. Durham), "There is death in the pot".

26 Oct. Professor W.J. Albery (Imperial College, London), "Photogalvanic cells for solar energy conversion".

9 Nov. Professor A.R. Katritzky (U. of East Anglia), "Some adventures in heterocyclics".

16 Nov. Dr. H.C. Fielding (Mond Division, I.C.I.), "Fluorochemical surfactants and textile finishes".

✧ 23 Nov. Dr. C. White (Sheffield U.), "The magic of Chemistry".

18 Jan. Professor J.C. Robb (Birmingham U.), "The plastics revolution".

✧ 8 Feb. Mr. C.G. Dennis (Vaux Ltd.), "The art and science of brewing".

* 1 Mar. Professor R. Mason (Govt. Scientific Advisor),
"The scientist in defence policy".

10 May Professor G. Allen (Chairman S.R.C.), "Neutron scattering for polymer structures".

Academic Year 1979-80

18 Oct. Dr. G. Cameron (U. of Aberdeen), "Synthetic polymers - twentieth century polymers".

25 Oct. Professor P. Gray (U. of Leeds), "Oscillatory combustion reactions".

1 Nov. Dr. J. Ashby (I.C.I. Toxicological Laboratory),
"Does chemically-induced cancer make chemical sense".

8 Nov. Professor J.H. Turnbull (R.M.C. Shrivenham),
"Luminescence of drugs".

✧ 15 Nov. Professor E.A.V. Ebsworth (U. of Edinburgh),
"Stay still, you brute: the shape of simple silyl complexes".

✧ 24 Jan. Professor R.J.P. Williams (U. of Oxford), "On first looking into biology's chemistry".

14 Feb. Professor G. Gamlen (U. of Salford), "A yarn with a new twist - fibres and their uses".

21 Feb. Dr. M.L.H. Green (U. of Oxford), "Synthesis of highly reactive organic compounds using metal vapours".

✧ 28 Feb. Professor S.F.A. Kettle (U. of East Anglia),
"Molecular shape, structure and chemical blindness".

6 Mar. Professor W.D. Ollis (U. of Sheffield), "Novel molecular rearrangements".

Research Conferences Attended

3rd Annual Congress of the Chemical Society, Durham,
9-11 April 1980.

First Year Induction Course

In each part of the course, the use and limitations of the various services available are explained by the people responsible for them.

Departmental organisation	Dr. E.J.F. Ross
Safety matters	Dr. M.R. Crampton
Electrical appliances and infra-red spectroscopy	Mr. R.N. Brown
Chromatography and microanalysis	Mr. T.F. Holmes
Library facilities	Mr. W.B. Woodward (Keeper of science books)
Atomic absorptiometry and inorganic analysis	Mr. R. Coult
Mass spectrometry	Dr. M. Jones
N.m.r. spectroscopy	Dr. R.S. Matthews
Glassblowing techniques	Mr. W.H. Fettis and Mr. R. Hart

REFERENCES

1. N.D.Khabbass, M.Sc. Thesis; Durham University 1979.
2. K.A.Petrov and G.A.Sokol'skii, J.Gen.chem. USSR., (1956), 26, 3378, Abstr. (1957), 51, 8029.
3. H.H.Sisler, A.Sarkis, M.S. Ahuja, R.J.Drago and N.L.Smith, J.Amer. Chem.Soc., (1959), 81, 2982.
4. S.R.Jain, L.K.Krannich, R.E.Highsmith and H.H.Sisler, Inorg.Chem. (1967), 6, 1058.
5. W.A.Hart and H.H.Sisler, *ibid.*, (1964), 3, 617.
6. D.F.Clomens and H.H.Sisler, *ibid.*, (1965), 4, 1222.
7. R.P.Nielson, J.F.Vincent and H.H.Sisler, *ibid.*, (1963), 2, 760.
8. R.Appel and D.Hänssgen, Angew. chem., Int.Ed. Engl., (1967), 6, 91.
9. R.S.Drago, J.Chem. Educ., (1957), 34, 541.
10. R.Chme, E.Schmitz and P.Wolge, chem.Ber., (1966), 99, 2104.
11. K.Utvary and H.H.Sisler, Inorg.Chem., (1966), 5, 1835.
12. K.Hoegerle and H.Erlenmeger, Helv.Chem.Acta, (1956), 39, 1203.
13. J.Meinwald, P.G.Gassmar and E.G.Miller, J.Amer.Chem.Soc. (1959), 81, 4751.
14. R.Appel and N.Buchner.Chem.Ber., (1962), 95, 849, chem.Abst.,(1962), 57, 5785.
15. J.A.Cogliano and G.L.Braude, J.org.chem.,(1964), 29, 1397.
16. R.Appel and G.Bucher, Ann.chem., (1965), 584, 112; chem. Abst.,(1965), 63, 8184.
17. H.Bock and K.L.Kompa, Z.Anorg. Allg. chem., (1964), 332, 238.
18. G.Alliger, U.S. Patent 2495085.(1950; chem.Abst., (1951), 45, 177).
19. J.Goerdeler and D.Loevenich, chem.Ber., (1954), 87, 1079; chem. Abst.,(1955), 49, 13259.
20. H.H.Sisler and S.R.Jain, inorg.chem., (1968), 7, 104.
21. H.H.Sisler and C.Stratton, *ibid.*, (1966), 5, 2003.
22. R.L.McKenney and H.H.Sisler, *ibid.*, (1957), 6, 1178.
23. K.W.Field and P.Kovacic, Synthesis, (1969), 135.
24. K.A.Petrova, V.A.Parshina, B.A.Orlov and G.M.Trypina, J.Gen.chem. USSR, (1962), 32, 3944.

25. G.H.Coleman and A.W.Campbell, J.Amer.Chem.Soc., (1928), 50, 2754.
26. C.R.Hauser, J.Amer.Chem.Soc., (1930), 52, 1108.
27. R.S.Neale. J.Org.Chem., (1967), 32, 3263.
28. R.S.Neale, J.Amer.chem.Soc., (1964), 86, 5340.
29. E.C.Sterling, Org.Synth.Coll. (1963), 2, 429.
30. E.Fluck and B.M.Reinisch, Chem.Ber., (1963), 96, 3085.
31. C.M.Sharts, J.Org.Chem., (1968), 33, 1008.
32. C.R.Hauser, A.G.Gillaspie. J.Amer.Chem.Soc., (1930), 52, 4517.
33. C.R.Hauser, A.G.Gillaspie and J.W. Le Maistre, ibid., (1935), 57, 567.
34. J.Stieglitz and I.Vasburgh, Chem.Ber., (1913), 46, 2151.
35. I.Vasburgh and J.Stieglitz., J.Amer.Chem.Soc. (1916), 38, 2081.
36. J.Jander and C.Lafrenz, Angew.Chem., (1966), 78(11), 6078.
37. R.S.Neale and M.R.Walsh, J.Amer.Chem.Soc., (1965), 87, 1255.
38. J.Jander and J.Fischer, Z.Anorg. Allg.Chem., (1961), 313; 37 Chem. Abst., (1962), 56, 15124.
39. J.G.A.Griffiths and R.G.W. Norrish, Proc. Roy.Soc., Sev. A., (1932), 135, 69.
40. J.G.A.Griffiths and R.G.W.Norrish, Trans. Faraday Soc., (1931), 27, 451.
41. L.K.Krannich and H.H.Sisler, Inorg.Chem., (1969), 8, 1032.
42. R.E.Highsmith and H.H.Sisler, ibid., (1968), 7, 1740.
43. A.J.Ellis and F.G.Soper, J.Chem.Soc., (1954), 1750.
44. K.Seppelt and W.Sundermeyer, Z. Naturforsch., (1969), 246, 754.
45. A.W.Hoffmann, Chem.Ber., (1879), 12, 984.
46. A.Schonberg, R.Monbasher and Z.M.Barakat, J.Chem.Soc., (1951), 2504.
47. G.H.Coleman, J.Amer.Chem.Soc., (1933), 55, 3001.
48. J.Jander, K.Knuth and W.Renz, Z.Anorg. Allgem. chem., (1972), 392, 155.
49. A.B.Burg and P.J.Slota, J.Am.Chem.Soc., (1958), 80, 1107-9.
50. H.Noeth and H.J.Vetter, Ber., (1963), 96, 1109-18.

51. K.Moedritzer, L.Maier and L.L.D.Groenweghe, *J.Chem.Eng.Data*, (1962), 7, 307.
52. J.R.Vanwazer and L.Maier, *J.Am.Chem.Soc.*, (1964), 86, 811.
53. F.Ramirez, O.P.Madan and C.P.Smith, *Tetrahedron*, (1966), 22, 567.
54. R.Schmutzler, *J.Am.Chem.Soc.* (1964), 86, 4500.
55. R.Schmutzler, *Angew.Chem. Intern.Ed.Engl.*, (1964), 3, 513.
56. H.S.Gutowsky and D.W.McCall, *J.Chem.Phys.*, (1954), 22, 162.
57. R.A.Y. James and A.R.Katritzky, *Angew. Chem.*, (1962), 74, 60.
58. J.Biess and J.R.Van Wazer, *Inorg.Chem.*, (1966), 5, 178.
59. S.Grim and W.Mcfarlane, *Nature*, (1965), 208, (5014), 995-6.
60. L.Maier, *Helv.Chim.Acta.*, (1963), 46, 2667.
61. K.A.Petrov, G.A.Sokol'skii and B.M.Polees, *Zh.obshch. Khim.*, (1956), 26, 3381.
62. A.C.Poshkus and J.E.Heruels, *J.Am.Chem.Soc.*, (1957), 79, 4245.
63. United States Patent Office, Patented Sept. 12.1967., 3, 341-632.
64. A.Schmidpeter and H.Groeger, *Chem.Ber.*, (1967), 100, 3988.
65. A.E.Lippman, *J.Org.Chem.*, (1965), 30(90), 3217-8.
66. V.Mark, C.Dungan, M.Crutchfield and J.Van Wazer, *p31 Nuclear Magnetic Resonance*, (1967), 5, 253.
67. E.S.Gould. *Mechanisms and Structure in Organic Chemistry*, Holt, Reinhart and Winston, 1969.
68. B.Miller, *Proc. Chem. Soc.*, (1962), 303.
69. A.Michaelis and L.Gleichmann, *Chem.Ber.*, (1882), 15, 801.
70. H.Köhler, *Chem.Ber.*, (1880), 13, 1626.
71. J.A.Salthouse and T.C.Waddington, *J.Chem.Soc. (A)*. (1966), 1188.
72. C.Walling. *U.S.Pat.*, (1948), 2, 437, 796.
73. C.Walling. *U.S.Pat.*, (1948), 2, 437, 798.
74. I.M.Kabachnik and P.A.Rossiiskaya, *Izv.Akad-Nauk.SSSR, Khim Nauk*, (1946), 403.
75. Zh. K.Gorbatenko and N.G.Feshchenko, *Zh.obshch. Khim.* (1977), 47(8), 1915-6.

76. H.N. Rydon and B.L. Tonge, *J. Chem. Soc.*, (1956), 3043.
77. P.J. Forsman and D. Lipkin, *J. Am. Chem. Soc.*, (1953), 75, 3145.
78. H. Noeth and H.J. Vetter., *Ber.*, (1963), 96, 1109-18, c.b. CA.55,22096a.
79. C.E.D. Corbridge, *J. Appl. Chem.*, (1956), 6, 456.
80. J.R. Parks, *J. Am. Chem. Soc.*, (1957), 79, 757.
81. E. Flück, *Z. Anorg. Allgem. Chem.*, (1962), 315, 181.
82. W. Gerrard and N.H. Philip, *Research (London)*, (1948), I, 477.
83. L.C.D. Groenweghe and J.H. Payne, *J. Am. Chem. Soc.*, (1959), 5, 1179.
84. B. Holmstedt and L. Larsson, *Acta. Chem. Scand.*, (1958), 5, 1179.
85. K.B. Dillon and A.W.G. Platt, unpublished work.
86. E. Fluck, *Z. Anorg. Allgem. Chem.*, (1963), 320, 64.
87. Booth and Bozarth, *J. Am. Chem. Soc.*, (1939), 61, 2927.
88. G.H. Blram and C.N. Matthews, *J. Am. Chem. Soc.*, (1965), 88, 4198.
89. Yu.A. Buslaev., E.C. Il'in and M.N. Shcherbakova, *Dokl. Akad. Nauk. SSSR, ser. khim.*, (1974), 219, 1154-6.
90. R.R. Holmes and W.P. Gallagher, *Inorg. Chem.*, (1963), 2, 433.
91. N. Feshchenko, and A.V. Kirsanov, *Zh. Obshch. Khim.*, (1960), 30, 3041, *J. Gen. Chem.*, (1958), 28, 719.
92. M. Baudler. *Z. Naturw.*, (1958), 13.b, 256.
93. M.M. Crutchfield, C.H. Dungan, J.H. Letcher, V. Mark and J.R. Van Wazer. ³¹P Nuclear Magnetic Resonance, *J. Wiley and Sons, Inc.* (1967), 5.
94. P.G. Maslov, *J. Phys. Chem.*, (1968), 72(5), 1414-24.
95. W. Seidel, *Z. Chem.*, (1963), 3, 429.
96. A.H. Cowley and S.T. Cohen, *Inorg. Chem.*, (1965), 4, 1221.
97. R.G. Cavell, *J. Chem. Soc.*, (1964), 1992.
98. R. Schmutzler, *Inorg. Chem.*, (1964), 3, 415.
99. S. Fleming and R.W. Parry, *Inorg. Chem.*, (1972), 11(1), 5.
100. J.F. Nixon and R. Schmutzler, *Spectrochim. Acta*, (1964), 20, 1835
101. F.L. Muetterties, W. Mahler, K.J. Packard and R. Schmutzler, *Inorg. Chem.* (1964), 3, 1298.

102. K.Nakamoto. Infrared and Raman Spectra of Inorganic and Coordination Compounds, (1978), 3rd Edition.
103. N.Muller, P.C.Lauterbur and J.Goldenson, J.Am.Chem.Soc., (1956), 76, 3557.
104. A.Michaelis and K.Luxembourg, Ber.Deux-Chem., (1895), 28, 2205.
105. A.C.Poshkus and J.E.Herwch, J.Am.Chem.Soc., (1957), 79, 4245.
106. Open University S304 Summer School Experimental Notes (SUP 01820 9) p35.
107. P.J.Durrant. Organic Chemistry, Longman 's, (1965).
108. E.Schwarzmann and J.R.Van Wazer, J.Am.Chem.Soc., (1960), 82, 6009.
109. M.L.Nielsen, J.V.Pustinger and J.Strobel. J.Chem.Eng.Data, (1964, 9, 167.
110. J.Emsley and D.Hall, The Chemistry of Phosphorus . Harper and Row, (1976).
111. A.B.Burg and J.E.Griffiths, J.Amer.Chem.Soc., (1960), 82, 3514.
112. T.C.Waddington and F.Klonberg. J.Chem.Soc., (1960), 2332.
113. K.B.Dillon, R.J.Lynch, R.N.Reeve and T.C.Waddington, J.C.S., Dalton (1976), 1243.
114. H.Binder and E.Fluck, Z.Anorg. Allgem.Chem., (1971), 381, 123.
115. E.Fluck, Z.Anorg.Allgem.Chem., (1963), 320, 64.
116. E.Schwarzman and J.R.Van Wazer, J.Am.Chem.Soc., (1961), 83, 365.
117. E.R.Malinowski, J.Amer.Chem.Soc., (1969), 91, 4701.
118. T.Vladimiroff and E.R.Malinowski, J.Chem.phys., (1967), 46, 1830.
119. R.G.Kidd and D.R.Traux, J.Am.Chem.Soc., (1968), 90, 6867.
120. R.G.Kidd and H.G.Spinney, J.Am.Chem.Soc., (1973), 95, 88.
121. E.R.Malinowski, T.Vladimiroff and R.F.Tavares, J.phys.chem., (1966), 20, 2046.
122. E.R.Andrew and V.T.Wynn, Proc.Roy.Soc., (London). Ser.A.(1966), 291, 257.
123. S.O.Grim, W.McFarlane, E.F.Davidoff and I.J.Marks, J.phys.Chem.,(1966), 70, 581.
124. D.Hellwinkel, Chem.Ber.,(1965), 98, 576.
125. D.A.Johnson, Some Thermodynamic Aspects of Inorganic Chemistry, Cambridge University Press, 1968.
126. R.G.Kidd and H.G.Spinney, Inorg.Chem.,(1973), 12, 1967.

