

Durham E-Theses

Experimental studies on the grass axonopus compressus (sw.) beauv and related species

Gledhill, D.

How to cite:

Gledhill, D. (1964) *Experimental studies on the grass axonopus compressus (sw.) beauv and related species*, Durham theses, Durham University. Available at Durham E-Theses Online:
<http://etheses.dur.ac.uk/9190/>

Use policy

The full-text may be used and/or reproduced, and given to third parties in any format or medium, without prior permission or charge, for personal research or study, educational, or not-for-profit purposes provided that:

- a full bibliographic reference is made to the original source
- a [link](#) is made to the metadata record in Durham E-Theses
- the full-text is not changed in any way

The full-text must not be sold in any format or medium without the formal permission of the copyright holders.

Please consult the [full Durham E-Theses policy](#) for further details.

ABSTRACT.

The genus Axonopus Beauv. is defined in the terms proposed by Chase (1911) and the pan-tropic distribution of the A.compressus(Sw.) Beauv. complex is commented upon. Seven taxa are proposed for West Africa. These include two new species, two new hybrid taxa, and a recently introduced species from America (A.affinis Chase). The seven taxa are:-

A.compressus (Sw.)Beauv.

A.brevipedunculatus Gledhill sp.nov.

A.flexuosus (Peter) Hubbard ex Troupin

A.arenosus Gledhill sp.nov.

A.affinis Chase

A.compressus x flexuosus Gledhill hyb.nov.

A.brevipedunculatus x compressus Gledhill hyb.nov.

The taxa are shown to differ morphologically, cytologically, and in their breeding mechanisms. Phenotypic variation is shown to affect spikelet length and leaf width, both of which characters have been afforded taxonomic importance by other workers. The species form a polyploid series, the first two being tetraploid, the second two being hexaploid, and the fifth being octoploid. A.compressus x flexuosus is approximately pentaploid, but plants with additional chromosomes, or which have lost chromosomes, are common.

A.compressus and A.affinis are sexual outbreeders, but are also self compatible. A.brevipedunculatus and A.arenosus are apomicts. The apomictic process is described for A.brevipedunculatus as obligatory autonomous automixis (Thomas, 1940). In this process the embryo sac is produced from a reduced megaspore, but a diploid 'egg' is formed due to the failure of one nucleus to divide. Such embryo sacs have a characteristic

seven-nucleate appearance, in which the 'egg' occupies a lateral position.

A.flexuosus is also capable of producing some apomictic offspring, but is probably a facultative apomict in wild populations. Both hybrid taxa are sterile.

Hybrids were obtained from three interspecific crosses and the hybrids are compared with their parents and with the natural hybrids.

The origin and taxonomy of the West African representatives of the genus are discussed. Their evolution is discussed in terms of polyploidy and apomixis. Two lines of relationship are recognised, one consisting of the sexual species (A.compressus, A.flexuosus and A.affinis) and the other of the apomicts (A.brevipedunculatus and A.arenosus).

Experimental studies on the grass
Axonopus compressus (Sw.) Beauv.
and related species.

D. Gledhill

Fourah Bay College

The University College of Sierra Leone

A thesis presented in candidature for
the Degree of Doctor of Philosophy
in the
University of Durham 1964



Introduction	1
Definition of the genus	2
Variation within the genus	4
History of the taxonomy of <u>A. compressus</u> (Sw.) Beauv.	7
Investigations on material brought into cultivation	17
Biometric comparison	26
Variability	35
Anatomical variation	52
Cytological variation	68
Reproduction and breeding mechanisms	79
Embryo sac formation	101
Experimental crosses	112
Discussion	124
Summary	150
Appendix 1	151
Appendix 2	169
Bibliography	172

Introduction

The present work is an investigation of the experimental taxonomy of a group of plants which suggested itself to the writer as one of a great number of such groups in Sierra Leone which exhibit wide ecological tolerance accompanied by considerable structural variation.

Carpet grasses (Axonopus species) are used widely in the tropics as protective cover crops to reduce erosion of road and rail embankments, as lawn grasses and as forage crops. They have probably been introduced from America and the West Indies into West Africa where they are now widespread, not only in artificial habitats but also in semi-natural habitats. Only one species, A. compressus (Sw.) Beauv., is listed in Hutchinson and Dalziel's Flora of West Tropical Africa (1938); but this species is very variable. In this thesis, an account will be given of this variability; the taxonomy of the A. compressus (Sw.) Beauv. complex, which in fact consists of several species, will be considered and clarified; and an account will be given of some of the evolutionary problems which are presented by the members of this complex.

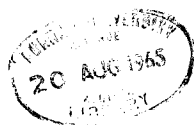

Definition of the genus Axonopus

Accounts of the early controversies as to the validity of the genus are contained in the literature (e.g. Chase, 1911 and Dedecca, 1956). These controversies stem originally from Beauvois' (1812) diagnosis, in which he himself expressed doubt as to the validity of splitting Axonopus from Milium and in which he cited four species as being representative of the new genus. In fact, these four species differ in respect of the arrangement of their inflorescences and spikelets. Together with their currently accepted names, they are:-

<u>Milium compressum</u> Sw.	(<u>Axonopus compressus</u> (Sw.) Beauv.)
<u>Milium digitatum</u> Sw.	(<u>Syntherisma digitata</u> (Sw.) Hitchc.)
<u>Milium cimicinum</u> Linn.	(<u>Alloteropsis cimicina</u> (Linn.) Staff.)
<u>Milium paniceum</u> Sw.	(<u>Syntherisma paniceum</u> Nash)

The controversies have served to establish Axonopus as a genus in which there is considerable uniformity amongst its members, the congeners of A. compressus (Sw.) Beauv., particularly in respect of the structure and orientation of the spikelet.

For the purpose of this thesis, the genus is defined in the terms proposed by Chase (1911), as follows:-

Inflorescence with two or more simple, slender, spike-like racemes digitately or sub-digitately arranged at the summit of the peduncle. Spikelets small to very small, solitary, biconvex,

adaxial, alternating on two faces of the triquetrous rachis and closely adpressed to it, falling entire with the rudimentary pedicels. First glume suppressed, second glume abaxial and equal to the spikelet. Lower floret reduced to its lemma which may resemble the second glume but may lack a mid-nerve. Fertile floret with sub-similar lemma and palea, the former with its back turned away from the rachis and embracing the latter marginally. Lodicules two, small, broadly cuneate. Stamens three. Styles two. Grain enclosed in the hardened lemma and palea, dorsally compressed. Hilum punctate, sub-basal. Embryo less than half the length of the grain.

Stoloniferous perennials, caespitose perennials or rarely annuals. Leaves more or less linear, flat, conduplicate or involute. Ligules very narrow, membranous and ciliate.

The key characteristics are those of the alternately arranged, solitary, sub-sessile, adaxial spikelets in which the first glume and sterile palea are lacking, and the racemes being aggregated at the summit of the peduncles.

The taxonomic position of the genus is in the tribe Paniceae of the sub-family Panicoideae. Appendix 1 contains an artificial key in which Axonopus is separated from allied genera, a table of distinguishing characters of the inflorescences of Axonopus and allied genera and a very brief history of the establishment of the genus Axonopus upon the type species Axonopus compressus (Sw.) Beauv..

Variation within the genus

Variation within the genus Axonopus mainly concerns habit, dimensions and hairiness. The leaf blades of stoloniferous species may be all alike (A. fissifolius (Raddi) Kuhlms.) or those on the stolons may differ from those on the culms (A. compressus (Sw.) Beauv.). A. stragulus Chase can be regarded as intermediate between the stoloniferous and caespitose species since it has short, geniculately ascending stolons. Most species are perennial but a few are annual (A. capillaris (Lam.) Chase, A. holochrysus (Trin.) Henr., A. appendiculatus (Presl.) Hitchc. & Chase). The leaves of many of the caespitose, bunch-grass species are folded and narrow (A. marginatus (Trin.) Chase, A. barbigerus (Kunth) Hitchc., A. siccus (Nees) Kuhlms., A. elegantulus (Presl.) Hitchc.), but those of the stoloniferous species are mostly flat or folding on drying. The anatomy of the spikelet is constant throughout the genus (except that nervation of the glume differs) but the size of the spikelets and the arrangement of the inflorescences show much variety. Spikelet length may be as little as 1.7 mm (A. ater Chase) or as great as 6 mm (A. obtusifolius (Raddi) Chase) and the proportion of the length which is occupied by the fertile floret varies from about 2/3 (A. flexuosus (Peter) Hubbard ex Troupin) to the whole (A. affinis Chase and A. fissifolius (Raddi) Chase).

A slight resemblance to Stenotaphrum is found in the sunken spikelets of A. chrysolepharis (Lag.) Chase, which has a broad rachis, but all other species have characteristic sub-spicate racemes which may be few (two in A. furcatus (Flügge) Hitchc.) or numerous (A. scoparius (Flügge) Hitchc.). The racemes themselves are arranged in digitate, racemose or even fasciculate (A. pubivaginatus (Flügge) Hitchc.) heads towards the summit of the peduncle.

Chase (1911) proposed three sections within the genus, based upon the distribution of hairs upon the inflorescence.

These are defined as follows:-

- (a) Euaxonopus: lacking hairs on the rachis of the inflorescence.
- (b) Cabrera: with golden hairs on the rachis but few, or none, on the spikelets.
- (c) Lappagopsis: with pale hairs on the rachis and pilose spikelets.

A. suffultus (Mikan) Henr. has a few, to many, golden to pale yellow hairs at the base of the spikelets and so is intermediate between Axonopus proper and the section Cabrera.

All the materials dealt with in the present work belong to the first section, Euaxonopus, and are all members of the Axonopus compressus (Sw.) Beauv. complex. This complex is

the only portion of the genus which is widely distributed outside the tropical American centre of proliferation. Because of its present wide distribution throughout the tropics and sub-tropics, its disjunct series of populations may be expected to show discontinuities in morphological and physiological variation patterns.

History of the taxonomy of
A. compressus (Sw.) Beauv. - sensu lato.

The oldest known specimen of Milium compressum Sw. is reputed to be that collected by Sloane (1696) in Jamaica. Swartz (1788) described this species also from Jamaican material and a specimen, contained in the Botanisches Staatssammlung, Munich, bearing the legend "Milium compressum Sw. Jamaica, O. Swartz.", may be part of the type collection. This and Swartz' second, more amplified, description (1798) clearly agree with the application of the name Axonopus compressus (Sw.) Beauv. to the common form from the West Indies.

Stapf (1909), in Prain's Flora of Tropical Africa, distinguishes Axonopus as having adaxial spikelets in which the second glume is wanting and the lower floret is reduced to its lemma. He describes Axonopus compressus (Sw.) Beauv. in very adequate terms so that it is clear that the description was based upon a large volume of material which exhibited considerable variation. This is particularly true for the values given for general dimensions and hairiness, but the description of the inflorescences as "subdigitate, sessile, erect or spreading spikes; common axis very slender;pedicels solitary, reduced to smooth elliptic subsessile discs." clearly agrees with Swartz' (1798) description. Stapf also notes that the species was "evidently introduced from South America".

Chase (1938) pursued her earlier (1911) observations on the recognition of a narrow-leaved form of A. compressus (Sw.)

Beauv. by describing it as a new species, A. affinis. This led to the re-examination of Axonopus in both Australia and Malaya. McLennan (1936) had already recognised that New South Wales material fell into two categories; those with narrow, $\frac{1}{4}$ - $\frac{3}{8}$ ins, leaves and those with broad, $\frac{3}{8}$ - $\frac{1}{2}$ ins, leaves. He had identified the narrow-leaved material as Axonopus compressus (Sw.) Beauv. with the synonym Paspalum platycaulon Poir. and left the broad-leaved material undetermined but with the synonym Paspalum compressum (Sw.) Rasp. Chase (1938) maintained that the Poiret and Raspail types were both broad-leaved and, therefore, themselves conspecific. Cross (1938) and Jagoe (1940) recognised the narrow-leaved materials of both Australia and Malaya as belonging to Axonopus affinis Chase. Jagoe listed a number of additional characters by which A. affinis Chase could be separated from A. compressus (Sw.) Beauv. but, by doing so, he made a descriptive departure from earlier descriptions by referring to the latter species as having short peduncles. Jagoe's illustration, and those of other workers, shows a short-peduncled plant which is strikingly similar to short-peduncled material which is common in West Africa. Since Swartz' description of the peduncles was "pedunculis longissimis", this character has been examined in some detail and is discussed later.

Chippindal (1955) admitted uncertainty concerning the

identification of the South African material. He found the leaf widths to agree with A. compressus (Sw.) Beauv. but the spikelet lengths to be more in accord with those of A. affinis Chase. This is also found to be the case amongst West African material and is also considered later.

Henrard (1945) described A. compressus (Sw.) Beauv. subsp. congoensis from the herbarium material collected by Hens and by Pobéguin in the Congo. The main characteristic of this subspecies is the greater spikelet length; up to 4 mm as compared with 2.2 mm. Other differences are narrower leaves and two additional nerves on the glume.

Peter (1930) described Digitaria flexuosa from Tanganyika in terms which leave no doubt that it should be a species of Axonopus, and that it is identifiable with Henrard's subspecies congoensis. In making the new combination, Troupin (1956) cited the herbarium materials of DeSaeger and of Noirfalise, from the Congo, to replace the no longer extant type of Peter. Troupin's diagnosis differs from that of Peter by including material of greater stature and with much broader leaves.

Avila de Araujo (1943) described a South American variety of A. compressus as also having larger spikelets, culms and leaves and gave it the varietal name jesuitica. This may be identical with West African A. flexuosus (Peter) Hubbard ex Troupin.

Gledhill (1962) described A. compressus (Sw.) Beauv. subsp. brevipedunculatus from Sierra Leone and noted that this was very widespread throughout West Africa and apparently in many other areas. The main characteristics of this subspecies were the short peduncle, the broad and usually hairy leaves and the longer hairy spikelets. It is now recognised that this taxon is composite and can be split into two distinct species and a hybrid taxon.

From the foregoing it is clear that the Axonopus compressus (Sw.) Beauv. complex, outside the American area, consists of populations between which discontinuities of both quantitative and qualitative characters have been recognised. The taxonomic treatments given to the complex have not taken into account the genetic aspects of control over the discontinuities in the variation patterns but have been based upon means of qualitative characters exhibited by materials from geographically or ecologically dissimilar areas. Variation within each taxon is considerable and in consequence the taxa are interconnected by intermediate individuals. Thus, a more reliable concept of the taxa must embody cytological characteristics and an understanding of the interrelationship between taxa.

In fact, seven taxa have been recognised of which five are given specific rank and two are regarded as interspecific

hybrids. Two of the five species are new, as are both the hybrids.

The seven taxa are:-

1. A.compressus (Sw.) Beauv.
2. A.compressus x flexuosus Gledhill hyb.nov.
3. A.flexuosus (Peter) Hubbard ex Troupin
4. A.brevipedunculatus x compressus Gledhill hyb.nov.
5. A.brevipedunculatus Gledhill sp.nov.
6. A.arenosus Gledhill sp.nov.
7. A.affinis Chase

Their diagnoses, synonymy and distributions are set out in full in Appendix 1.

The names given to the hybrid taxa are constructed in accordance with Article H.1. of the International Code of Botanical Nomenclature (1961) by the formulae in which the specific epithets of the putative parents are placed in alphabetic order. Thus, the names do not purport to show which parent was pollen or seed parent, but simply that the taxa are of intermediate nature between the two putative parent species.

From this point the seven taxa will be referred to by their binomials or formulae, without citation of authorities.

As has been stated earlier, the complex which these taxa constitute today extends as a series of disjunct populations throughout the tropics and some subtropical areas (see

figure 1, which shows the known distribution of Axonopus species). Introduction into Queensland and into New South Wales, Australia, and into Singapore in 1895 was intentional. It is also likely that introductions into other tropical areas may have been intentional, where such areas were developing as cattle rearing areas. Much less likely is introduction, other than accidental introduction, into the Tsetse areas of West Africa. Attempts were made to establish Axonopus as a cover crop in Senegal and Morocco, but these failed. Elsewhere in West Africa the methodical establishment of pastures, using already present Axonopus, is quite a recent practice (Nigerian Grass Yearbook, 1948) and is confined to the non-Tsetse areas. It is likely, therefore, that the present distribution of the complex in Africa (throughout the medium altitude moist forest formations of the Western Guinea area from Gambia to Angola and across the Congo into East Africa from Kenya to South Africa) is the consequence of easy transport of seed. This transport may have started when these forest areas became linked by slave trading with the American centre of origin.

With the exception of the material of A. affinis, all the living material examined for this work is of West African origin. The localities and their reference numbers are listed in Appendix 2, as are the names of herbaria whose collections have been examined.

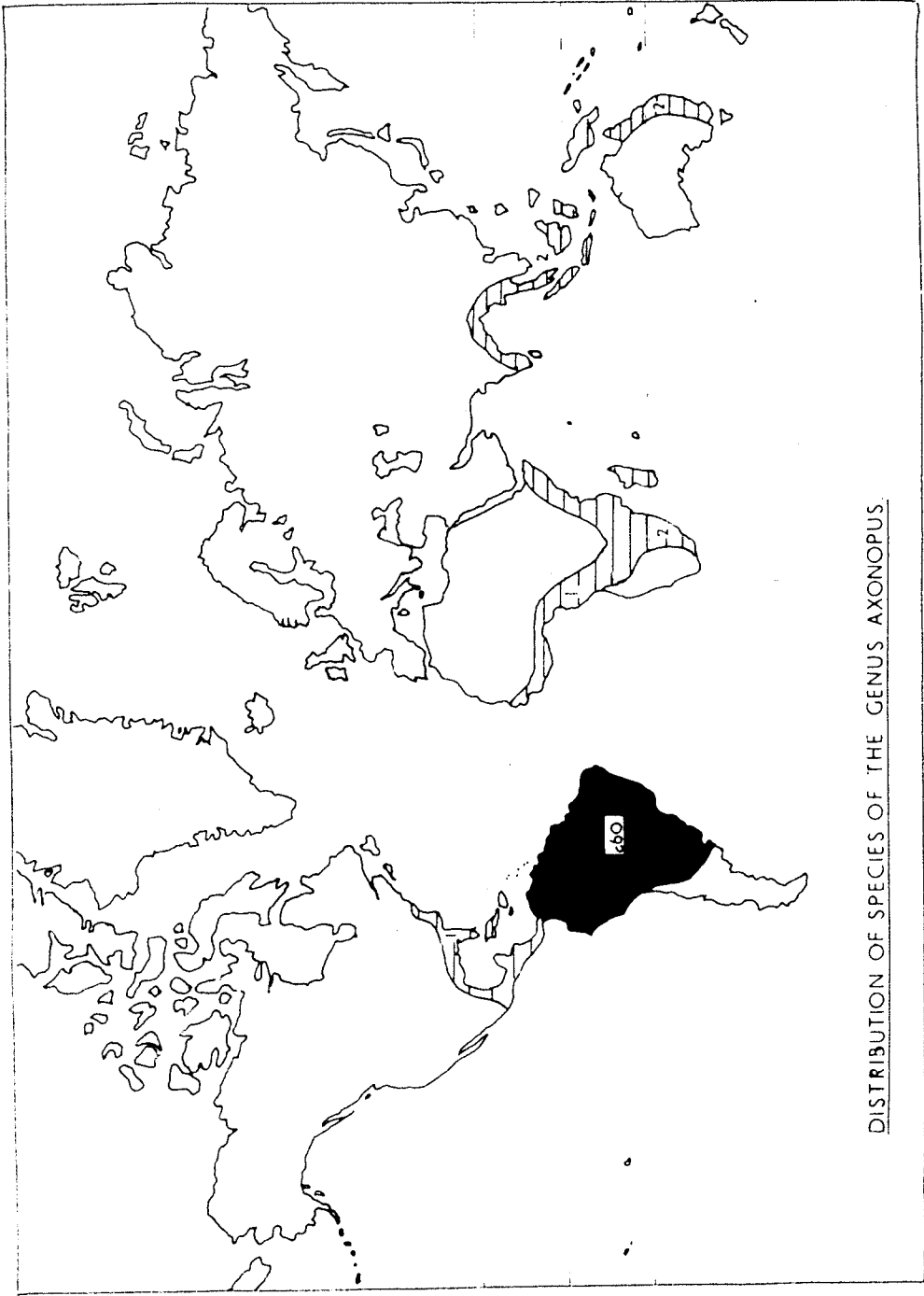

DISTRIBUTION OF SPECIES OF THE GENUS *AXONOPUS*.

FIGURE 1

The following key and table of characteristics may be of use in identifying the taxa to which the investigations refer:-

Peduncles not much longer than the ultimate leaf-sheath.

Leaves and nodes glabrous; spikelets over 3 mm long and with few adpressed hairs. A. arenosus.

Leaves and nodes hairy; spikelets up to 3 mm long and silky-hairy.

At least the first racemes becoming fully exerted from the ultimate leaf-sheath; ultimate leaf about half as long as its sheath; often anthocyanosed.

A. brevipedunculatus x compressus.

Racemes seldom fully emerging from the ultimate leaf-sheath; ultimate leaf less than half the length of its sheath; dark green.

A. brevipedunculatus.

Peduncles much longer than the ultimate leaf sheath.

Spikelets over 2.7 mm long; racemes more than 9 cms long, flexuous.

Stolon internodes over 12 cms long, stout.

A. flexuosus.

Stolon internodes up to 10 cms long, slender.

A. compressus x flexuosus.

Spikelets less than 2.7 mm long; racemes less than 9 cms long, straight.

Peduncles straight; leaves lanceolate, 6 - 9 mm wide, sub-acute; fertile lemma with a conspicuous apical tuft of hairs. A. compressus.

Peduncles flexuous; leaves linear, 3 - 7 mm wide, abruptly obtuse to sub-acute; fertile lemma with an inconspicuous or no apical tuft of hairs.

A. affinis.

The following table of characters is supplementary to the biometric comparison contained in Table 3.

Table 1

	A. compressus	A. breviped.	A. flexuosus	A. arenosus	A. affinis
fertile floret	\pm equals glume	$3/4$ length of glume	$2/3$ length of glume	$2/3$ length of glume	equals glume
anther colour	pale mauve	yellow-brown	dark mauve	brown-mauve	dark mauve
stigma colour	pale mauve	pale mauve	dark mauve	mauve	dark mauve
glume apex	obtuse toothed	sub-acute toothed	sub-acute toothed	obtuse toothed	obtuse entire
glume nerves	4 - 5	5	5 - 7	5 (- 7)	4
leaf hairs	few, margin ciliate	hispid, margin ciliate	glabrous, margin \pm ciliate	glabrous, margin \pm ciliate	few, margin ciliate
leaf apex	asymmetric sub-acute	asymmetric \pm obtuse	\pm symmetric, sub-acute	symmetric sub-acute	symmetric obtuse
innovations	\pm erect	prone	erect	\pm erect	ascending
peduncles	long exerted	not exerted	exserted	not exerted	long exerted
stolons	usually short	extensive	massive arched	few, short	extensive
habit	tufted	spreading	rank, matted	tufted and spreading	spreading
habitat	bush paths etc.	ditches banks	flood plains	maritime	only in cultivation

Table of some of the characters which distinguish five species of

Axonopus.

Investigations on material
brought into cultivation

Selection of material

The use of Axonopus compressus - sensu lato - for lawns etc. has played a definite part in the spread of the complex throughout West Africa. One consequence of this is that Axonopus appears as a ruderal weed around habitations and on farms, embankments and ditches. Together with the shifting nature of West African agriculture this has led to the introduction of Axonopus as a component of secondary and diverted plant communities. Axonopus under cultivation and Axonopus growing in habitats which are not, and cannot be, cultivated represent the two extremities of its occurrence in West Africa. Between these two conditions, Axonopus occupies a wide range of habitats in which human activity may have been, has been or still is partly responsible for its presence. Although these intermediate conditions are, in a sense, artificial, they represent transient stages in secondary seres and, because it is virtually impossible to discover the past history of such habitats, it is reasonable to regard them as natural and to regard Axonopus, in them, as occurring sub-spontaneously.

In selecting material for this work, only natural populations (i.e. those in which human interference was absent or was evidently passive or unintentional) were sampled. No population which looked as though it might have been intentionally planted was sampled for material for cultivation. Observa-

tions were made, however, on planted populations, for the purpose of examining the effects of imposed conditions and treatments upon the morphology of the various taxa. These observations are considered later.

In all cases of collection by the writer (see Appendix 2), ten plants were selected at random from the population. Material obtained from other sources was obtained either as whole plants or as seed. Whole plants were stood in water for 24 hours and were then planted in experimental beds. Seeds were germinated on steam sterilized soil in plastic pots, and were then planted out, either in experimental beds or into deep wooden boxes until conditions were suitable for planting out.

The first year of growth in experimental beds, in all cases, produced a closed cover, almost entirely due to vegetative spread, in which the identity of the original plants was lost.

Selection of characters for investigation

The writer's first encounter with Axonopus was in 1955, when he identified his first collection using the Flora of West Tropical Africa (Hutchinson and Dalziel, 1938). The agreement with the description was so slight that further collections were made and the collections in the Sierra Leone Agricultural Department herbarium, Njala, were examined. A number of sheets in the Njala collection were found to bear the

name Axonopus africanus Hubbard but the only notes as to the distinguishing features of this 'species' referred to its having longer spikelets than A. compressus. A few plants were collected and grown in pots and were found to remain distinct in respect of a number of morphological characters, in addition to spikelet length. These characters included:-

1. The density of tillering.
2. The production and length of stolons.
3. Height.
4. Exsertion of inflorescences.
5. Leaf size.
6. Coloration of leaves etc. by anthocyanin.
7. Hairiness.
8. Anther and stigma colours.
9. Fruiting.

Originally these materials were classified as A. compressus or A. africanus (an illegitimate name proposed by Hubbard for long spikelet material and which appeared in Deighton's 'Vernacular Botanical Vocabulary for Sierra Leone' 1957). It soon became obvious that populations did not fall into two simple categories but rather into three (A. compressus, 101 etc., in Appendix 2, A. flexuosus, 201 etc., and A. compressus subsp. brevipedunculatus, 301 etc.). The second and third of these categories were later found to be further

divisible; the second into A. flexuosus and a putative hybrid and the third into A. brevipedunculatus, a putative hybrid and A. arenosus.

The early recognition of three categories arose from the fact that much of the long spikelet material had characteristic short peduncles. Both Henrard's (1945) description of A. compressus subsp. congoensis and Peter's (1950) description of Digitaria flexuosa (which Hubbard, in conversation, had suggested to the writer was the basis of what had become known as A. africanus, but which should become A. flexuosus) refer to their tall habit and long, flexuous inflorescences. The third category, erected as A. compressus subsp. brevipedunculatus Gledhill (1962), was set up to include material with long, hairy spikelets, short peduncles and leaves which were hispid above and frequently anthocyanosed.

Characters such as red pigmentation and hairiness and arching of stolon internodes do not lend themselves to easy, critical comparison in the same way as numerical or dimensional characters. These characters were recorded, therefore, in arbitrary terms; e.g. very hairy, + + +, hairy, + +, sparsely hairy, +, glabrous, -, for anther and stigma colour, dark mauve, mauve, pale mauve, or by comparison with the condition found in A. compressus.

Both seasonal and environmental changes were found to

be accompanied by variation in general dimensions. This variation was detected when measurements of general dimensions were made in January, April and October (i.e. in the early part, at the end and at the beginning of the dry season) and were compared. The characters chosen for the biometric comparison of the taxa were found to express the differences in general dimensions adequately and reliably. They were:-

1. Lengths of culm, culm-leaf and culm-sheath.
2. Dimensions of tiller-leaves.
3. Dimensions of stolon internodes.
4. Length of the longest raceme.
5. Length of spikelets and fertile floret.

In addition, comparisons were made of the average numbers of spikelets produced on a single culm, the hairiness of nodes, leaves and spikelets, the weight of fruits and the percentage of pollen which stained with aceto-carmin.

With the later recognition of putative hybrid taxa, anatomical characters of the spikelets, leaves, stolons and roots were examined.

Methods of sampling cultivated material

As has been stated, the identity of the original ten plants in each experimental bed was lost after they had together formed a closed cover. This did not prevent repeated sampling, however, and the experimental populations were examined in

October and January, each year from 1957 to 1963. April examinations were discontinued because dieback and scorching prevented adequate sampling.

The method of selecting material from the experimental beds was to remove ten specimens, from different parts of the bed, each specimen having a tiller with culms and stolons. This ensured against the possibility of obtaining as a sample material which was all the product of only one of the original plants.

By making two measurements for each character on each of the specimens, a sample of twenty measurements was obtained.

The stolon internodes were scored by measuring the lengths of the basal internode and the antipenultimate internode of each of ten stolons. This was thought more likely to provide more accurately comparable figures because of the differences which exist between the taxa, in respect of the number of internodes which are normally produced (A. flexuosus and A. compressus x flexuosus, for example, produce long but few-noded stolons). It was also thought that this method of sampling would tend to correct errors which might otherwise have resulted from measuring internodes at different stages of development.

Innovation leaves were sampled by measuring the lowest unwithered leaf on the innovation. The dimensions of these leaves have not been employed in the biometric comparison be-

cause they depend upon the age and state of development of the stolon and also upon the state of establishment of the innovation itself. Since the stolons of some taxa are true 'creeping stems' and those of other taxa are arched and, finally, geniculate, it was thought that no true comparison could be made between rooted and aerial innovation leaves. The characteristic inclinations of the innovation leaves were recorded and have been mentioned in Table 1.

Raceme length varies on one and the same peduncle. The upper two racemes are of approximately equal lengths but the third (or lowest if there are more than three) is longer. Since some peduncles have only two racemes, it was decided to employ the character 'longest raceme' in preference to the mean of a sample.

Spikelet dimensions were scored from bulk, mature, fallen spikelets. In scoring these dimensions, only undamaged spikelets were used. Aphid damage could be detected as perforation of the second glume, usually accompanied by fungal infection. Fallen but non-fruiting spikelets were scored. The reason for this discrimination was that aphid attack of young spikelets causes them to fall prematurely, but some spikelets, which have not been attacked, grow to their full size without fruiting. This is particularly the case in the sterile putative hybrids.

Methods of measurement

Measurement of the culm, its leaf and sheath, of tiller leaves and stolons were made with a steel scale, graduated in half millimeters. This permitted estimation of lengths to the nearest tenth of a millimeter.

The smaller measurements were made microscopically, using a x2 objective and a x6 ocular and with the body length adjusted to convert the eyepiece graticule divisions into equivalents of 100 stage divisions each of 0.05 mm.

Biometric comparison of the taxa

Comparison of morphological dimensions

Tables 2, 3 and 4 attempt to compare the dimensions of various structures in each of the taxa.

Table 2 is based upon samples of 20 measurements for each parameter, except in the case of spikelet length, for which samples of 100 were employed. The measurements were made in October, 1961. In addition to the sample means, the table gives the standard errors of many of the means (being those which were most extensively investigated) and, in the lower part of the table, arbitrary assessments of the hairiness of the nodes, leaves and spikelets.

It will be seen that for most of the parameters the taxa differ widely, even when they are grown side by side. Thus, differences which were first noted in the field are shown to be more than phenotypic responses to the influences of the environments. Shortening of the peduncles was at first thought to be entirely due to cutting or trampling but, although such a response does occur, as will be discussed later, the persistence of such shortening in three of the taxa indicates that in those taxa the control of the short peduncle character is genetic.

The standard errors of the means in Table 2 provide expressions of the variability within each sample and also indicate the significance of differences between mean values for

Table 2

Characterisation of the taxa - the means are for samples of 20 measurements, 100 in the case of spikelet length, fruit weight and % good pollen, and the lower figures are standard errors.

Culm length	26.3 ±0.34	52.8 ±1.63	56.8 ±1.11	19.2 ±0.55	14.3 ±0.43	14.2 ±0.02	27.9 ±0.55
Culm-sheath	9.1 ±0.39	15.6 ±0.41	25.0 ±0.02	13.4 ±0.33	11.4 ±0.34	8.6 ±0.03	14.5 ±0.32
Culm-leaf	6.6 ±0.31	8.4 ±0.22	7.2 ±0.09	7.1 ±0.28	4.8 ±0.25	2.9 ±0.30	3.9 ±0.13
Tiller-leaf length	15.7 ±0.24	41.4 ±0.46	24.3 ±0.67	11.4 ±0.43	12.3 ±0.34	11.1 ±0.42	17.3 ±1.04
Tiller-leaf width (mm)	9.9 ±0.33	14.7 ±0.17	20.9 ±0.19	9.5 ±0.46	13.5 ±0.09	15.2 ±0.20	7.0 ±0.12
Stolon internode	5.4 ±0.15	7.5 ±0.21	26.4 ±0.33	2.6 ±0.04	2.5 ±0.07	4.6 ±0.15	1.3 ±0.12
Stolon width (mm)	1.3	2.3	4.5	2.3	2.2	2.7	1.2
Longest raceme	7.0	14.0	16.0	8.0	6.0	8.5	6.5
Spikelet length (mm)	2.2 ±0.020	2.9 ±0.030	3.3 ±0.022	2.7 ±0.022	2.8 ±0.023	3.2 ±0.043	2.3 ±0.023
Fertile floret	1.6	1.9	2.0	1.8	1.8	1.9	1.8
Spikelets/culm	210	422	370	265	172	197	205
Fruit weight mgm/100	20	-	30	-	30	30	20
% good pollen	96	17	96	30	87	95	96
Nodal hairs	+	+	-	++	+++	-	+
Leaf hairs	+	-	-	+	++	-	-
Spikelet hairs	+	+	-	+	++	+	+
	A	B	C	D	E	F	G

A - A. compressus

B - A. compressus x flexuosus

C - A. flexuosus

D.- A. brevipedunculatus x compressus

E - A. brevipedunculatus

F - A. arenosus

G - A. affinis

pairs of taxa. If the difference between two mean values is less than twice the standard error, the difference could have arisen through sampling errors, but if the difference exceeds twice the standard error, there is a high probability that the means are derived from two distinct populations which exhibit little or no overlap.

The variability within each taxon can also be expressed as the Coefficient of Variation ((standard deviation x 100) ÷ mean) and some figures are given in Table 3.

Table 3

Coefficients of Variability

(The taxa are referred to in the same order as in Table 2.)

Culm length	5.64	13.38	6.77	12.48	13.11	0.19	8.59
Culm-sheath	18.68	11.46	0.38	11.74	13.00	1.91	9.62
Culm-leaf	8.61	11.41	0.54	17.19	22.71	45.09	14.69
Tiller leaf length	6.66	4.84	12.00	16.44	12.05	16.10	26.20
Tiller leaf width	14.53	5.04	3.96	21.11	2.91	0.57	7.37
Stolon internode	12.11	12.20	5.45	6.71	12.19	14.21	40.24
Spikelet length	9.04	10.29	6.63	8.11	8.17	13.38	9.95
	A	B	C	D	E	F	G

The most variable parameters are the stolon internodes of A. affinis and the culm leaf length of A. arenosus. A. compressus is seen to be variable in culm-sheath length, tiller-leaf width and

stolon internode length. A. compressus x flexuosus is least variable in its tiller-leaf dimensions but is more variable in most of the other parameters than either of its putative parents. A. flexuosus is very uniform in all but tiller-leaf length. A. brevipedunculatus x compressus is fairly variable in all but stolon internode and spikelet lengths. A. brevipedunculatus is also fairly variable in all but leaf width and spikelet length. A. arenosus is very variable in leaf, stolon internode and spikelet lengths but is very uniform in the other parameters. A. affinis is variable in leaf dimensions and stolon internode length.

A. compressus x flexuosus can be seen from Table 2 to be intermediate between its putative parents in all the parameters except leaf lengths, the numbers of spikelets per culm and the percentage of good pollen produced (the two last will be discussed later). This in itself suggests that it is hybrid and appears to be confirmed by the greater variability exhibited by it.

Table 2 also suggests that A. brevipedunculatus x compressus has intermediate dimensions between those of its putative parents. The greater resemblance to A. brevipedunculatus in most of the characters suggests that introgression to that parent may have taken place. As with the other hybrid, the variability of A. brevipedunculatus x compressus is generally greater

than that of either of the putative parents.

Table 4 attempts to emphasise the differences between the taxa by comparing the means of the parameters. In it, t-values of 3.29 or less can be interpreted as showing that there is no significant difference between that particular pair of mean values. More strictly, such low t-values indicate that the differences may have arisen through sampling errors. Of the various parameters, none is found to be of value in diagnosing every one of the taxa. Each taxon can, however, be characterised by one or a pair of parameters. Thus, the culm-sheaths of A. flexuosus are of significantly different length from those of any other taxon, as are those of A. brevipedunculatus. Similarly, tiller-leaf width characterises A. affinis and culm height combined with culm-sheath length characterises A. arenosus.

One point which appears from Table 4 is that spikelet length alone can not be employed to define any one of the taxa. This is an important point in the taxonomy of this group and will be considered in greater detail in connection with the changes in spikelet length which result from seasonal changes and from habitat conditions, in the section on variability.

The comparison of spikelet lengths in Table 4 suggests that there is a slight significance in the difference between A. affinis and A. compressus but that there is very little be-

Table 4

Significance of Differences between means

(the taxa are referred to in the same order as in Table 2)

	A	B	C	D	E	F
<u>Culm lengths</u>						
B	15.9					
C	26.2	2.0				
D	11.0	19.6	30.3			
E	21.8	22.9	35.6	7.1		
F	30.6	23.7	39.2	9.2	0.2	
G	2.5	14.5	23.3	11.2	19.4	24.8
<u>Culm-sheaths</u>						
B	11.4					
C	40.3	22.7				
D	8.4	4.2	35.3			
E	4.4	7.8	39.5	4.2		
F	1.3	16.9	500.7	14.6	8.1	
G	10.7	2.1	32.4	2.4	6.6	18.3
<u>Culm-leaves</u>						
B	4.7					
C	1.8	5.0				
D	1.2	3.7	0.3			
E	4.5	10.8	9.1	6.2		
F	8.6	14.9	13.9	10.3	4.9	
G	8.0	17.6	21.2	10.5	3.2	3.1
<u>Tiller-leaves</u>						
B	49.8					
C	12.1	20.9				
D	8.8	47.6	16.2			
E	8.2	50.4	15.9	1.6		
F	9.5	48.4	16.7	0.5	2.2	
G	1.5	21.2	5.6	5.2	4.6	5.5

Table 4 contd.

	A	B	C	D	E	F
<u>Tiller-leaf widths</u>						
B	12.9					
C	28.9	24.3				
D	0.7	10.6	22.9			
E	10.5	6.2	35.4	8.5		
F	13.7	1.9	20.9	11.4	6.9	
G	8.2	36.6	61.6	5.2	42.8	35.3
<u>Stolon internodes</u>						
B	8.3					
C	57.9	48.4				
D	18.4	23.3	71.1			
E	17.9	23.0	70.5	1.2		
F	3.8	11.3	54.6	12.6	12.5	
G	21.4	29.5	98.7	9.9	8.5	16.8
<u>Spikelets</u>						
B	20.6					
C	37.8	10.8				
D	17.2	5.4	19.3			
E	20.1	2.6	15.7	3.1		
F	21.3	5.7	2.1	10.3	8.2	
G	3.4	15.9	31.4	12.6	15.4	18.5

tween A. flexuosus and A. arenosus. Neither putative hybrid is significantly different from A. brevipedunculatus but the hybrids themselves are different.

The comparative figures for the numbers of spikelets produced per culm can be interpreted as comparative reproductive potentials, and are considered as such in the section on reproduction and breeding mechanisms. The numbers themselves are functions of the length of the racemes and the number of racemes produced on each culm. A. compressus and A. affinis, with comparable spikelet and raceme lengths, also resemble each other in the number of racemes produced on each culm. A. flexuosus and A. arenosus, on the other hand, have comparable spikelet lengths but the latter has fewer, shorter racemes. A. flexuosus and A. compressus x flexuosus differ in that the lower spikelets of the latter are separated along the raceme by intervals approximately twice the length of the spikelets, while the number of racemes produced by the hybrid greatly exceeds that produced by A. flexuosus. The inflorescences of A. compressus x flexuosus have a fascicled appearance.

Variability

The data in Tables 2, 3 and 4 do not present a full picture of the extremes of variation within a taxon or of the morphological overlap between taxa. Specimens collected from the same habitat at different seasons, or from different habitats at the same season, were found to have widely different dimensions, but were also found to become inseparable when grown under the same conditions. Similarly, certain treatments, such as trampling and mowing, were found to induce great morphological modifications which can be regarded as phenocopies of other taxa.

Four approaches have been made to the study of the variability exhibited by Axonopus taxa for this work. They are:-

1. Culture of clonal material in various soil types.
2. Culture of clonal material under two dissimilar environments.
3. Mowing.
4. Biometric examination of cultured material at two seasons.

1. Culture of clonal material in various soil types.

The first of these approaches was an attempt to investigate the affects of various types of soil (sand, sterilized topsoil, graded lateritic soils - from 1.5 cm gravel down to those fractions which passed through a 70 mesh/cm sieve) upon

the growth of clonal material of A. compressus (a single plant from Mt. Aureol, 101, was used).

Distilled water alone was supplied to these cultures but, apart from deficiency colourations and lesions which developed in the sand and lateritic soil cultures, the difficulty of maintaining equivalent water supplies made it doubtful that this investigation would give any useable results. For example, evaporation from the sand and larger grained lateritic soil cultures rapidly produced a dry, protective surface layer in which the plants were very loosely rooted. In the topsoil and fine lateritic soil fractions, to which the same volumes of water were added, the soil was nearly water-logged and losses by evaporation were less. A control experiment, using a free water surface of equal area to the exposed soil surfaces, showed rates of loss to the air of up to 0.1 cc per hour. It was decided, therefore, that the investigation could not reasonably be pursued without facilities for controlling the environment and so reducing variations in soil-water-content. The investigation was abandoned in favour of reciprocal transplanting of clonal materials into two dissimilar environments.

2. Culture of clonal material under two dissimilar environments.

Single plants were removed from the experimental beds and were divided into two. Each pair of plants was potted in sterilized litter topsoil and one member of each pair was placed

in a wet, shaded habitat while the other member of each pair was placed in a dry, exposed habitat. The pots were watered every morning and every evening, throughout the investigation. The plants were examined frequently but, since it was hoped to detect the extremes of variation, only the outstandingly different features were recorded.

Under shaded, wet conditions, A. compressus was indistinguishable from West Indian material examined. Spikelet length increased to 2.3 mm and the longest lower leaf recorded was 20 cms long and was twisted into a loose spiral. Under the same conditions, A. brevipedunculatus produced spikelets 3.4 mm in length and lower leaves up to 30 cms long and twisted into a somewhat tighter spiral. A. compressus x flexuosus produced spikelets up to 4 mm in length but the lower leaves, which were up to 30 cms long, were rigidly erect and had a tendency to fold along the main nerves.

Moderate shading affects tillering and stoloniferous spread. Under shade all taxa produced stolons and the innovations from these rooted firmly in the surrounding soil. A. flexuosus was most vigorous in this respect and A. compressus was least vigorous. Fairly heavy shade, however, reduced the vigour of A. flexuosus in terms of stolon production. Under exposed conditions, A. flexuosus is the least stoloniferous taxon but, although the stolons produced by other taxa (particularly

A. affinis, A. brevipedunculatus x compressus and A. compressus x flexuosus) may be extensive, their innovations seldom become established well enough to persist through the dry season.

Exposure and drier soil conditions stunted the growth of all taxa. A. brevipedunculatus and A. arenosus produced rosettes and short, many-noded stolons. A. compressus and A. flexuosus produced tussocks with few, initially arching stolons. Under exposed and drier conditions, A. compressus x flexuosus was very similar to West Indian A. compressus, particularly as its spikelet length was decreased to 2.7 mm.

Differences in susceptibility to wilting were also noted. A. compressus wilted most easily and before A. flexuosus. The leaves of A. affinis and A. compressus x flexuosus folded but remained rigid even to the state of dehydration from which they failed to revive after watering. A. brevipedunculatus and A. brevipedunculatus x compressus withstood dry conditions without wilting and A. arenosus exhibited a slight tendency to leaf folding. The last three taxa developed terminal leaf lesions which are characteristic of the first two, but not of the third, in natural populations.

Changes in the habit of single plant pot cultures, on which the above observations were made, are of the same nature as those observed in less disturbed field populations. In these latter, such factors as shading and water supply are influenced

by seasonal changes and topography. They therefore present a much more varied but less extreme picture of phenotypic changes in morphology than do cultures under artificial regimes. Soil conditions in the field are influenced by the type of surrounding vegetation, agriculture and elevation and have a considerable effect on Axonopus. The most cosmopolitan taxa, A. compressus, A. brevipedunculatus and A. brevipedunculatus x compressus, flourish on a range of organically rich soils and survive on agriculturally impoverished lateritic soil and sands. A. flexuosus is confined to fluvial and alluvial soils on seasonal flood plains and its putative hybrid, A. compressus x flexuosus, has a wider distribution on similar, inland soils. A. arenosus is confined to sandy soils which can best be compared with grey dune soils. The last taxon is difficult to cultivate on non-sandy soils, apparently because of the absence of the stimulus of burial by blown sand. A. flexuosus can be cultivated on lateritic soil but loses vigour as a result. On organically rich soil, hairiness decreases, anthocyanin decreases and in A. arenosus, A. brevipedunculatus and A. compressus leaf width increases and the leaf margins become undulating.

3. Mowing.

Mowing of Axonopus lawns was found to cause important morphological changes. Similar changes were observed in natural

populations which were grazed or trampled. Lawns are started by dibbling in tufts of Axonopus at about 20 cm intervals. The initial growth is stoloniferous but consolidation of the turf is largely due to rhizomatous growth. In order to maintain a close turf it is necessary to irrigate and mow frequently. Two of the effects of mowing are to prevent flowering and at the same time to encourage lateral vegetative spread. As the closed turf forms, the competition between plants increases.

A. compressus, when mown, produces fewer stolons and those which are produced have shorter internodes. This is partly due to the ascending posture of the young stolons and their inability to penetrate, back through the turf, to the soil. The leaf-sheaths and leaf-blades become shorter and the leaves narrower, in a close turf. Culms only form under humid and overcast conditions and they are then usually inclined, rather than erect, and the inflorescences are shorter. The shortened culms resemble those of A. brevipedunculatus but flowering is free, although different from flowering in isolated plants. Each spikelet flowers soon after it emerges from the mouth of the leaf-sheath, so that the spikelets at the apex of one of the short racemes contain maturing fruits by the time that the lowest spikelets are exposed. The peduncles seldom greatly exceed the leaf-sheath in length.

The narrow leaves may be as little as 5 mm wide but

they remain distinct from those of A. affinis because they are thinner, shorter and more acute at the apex. When a plant having narrow leaves and short culms is removed from a lawn and cultured in isolation, it reverts to the production of normal width leaves and long culms and also produces stolons with long internodes.

The much larger A. flexuosus and A. compressus x flexuosus are not suitable for lawns, nor do they tolerate close mowing. They can be cut down to 10 cms but this only exposes the soil and litter which always accumulates under their rank, high arching stolons. No morphological modifications have been noted to result from such mowing.

A. brevipedunculatus and A. brevipedunculatus x compressus and, to a lesser extent, A. arenosus tolerate close mowing. They form rosettes in which the crowded leaves are of reduced length but normal width. Shortening of the culms is pronounced and, as the peduncles are also shortened, only as few as ten spikelets may be exposed beyond the mouth of the leaf-sheath. In A. brevipedunculatus and A. arenosus fruiting occurs within the sheath.

A. affinis responds slowly to mowing and does not consolidate as well as A. compressus. It forms a somewhat open turf with long stolons. The internodes of these are numerous and short and the leaves from the innovations are ascending.

The wiry culms evade cutting by cylinder mowing machines and no morphological changes in culm length have been detected.

4. Biometric examination of cultured material at two seasons.

Seasonal variation in four characters is demonstrated in Table 5 for four taxa. These four characters were chosen because they are those which have been employed by others to distinguish the taxa and also because the culm dimensions are important in expressing the external appearance of the taxa. Table 5 is compiled from measurements accumulated between 1957 and 1963, except in the case of A. affinis for which the figures were compiled from measurements made during 1962 and 1963 only. The culm characters are based upon samples of 120 measurements and the spikelet lengths upon samples of 100 measurements. The mean values and their standard ^{errors} deviations ($s(\bar{x})$) are recorded and the values for January and October are compared by the use of Student's t test. Values of t less than 3.29 have probabilities greater than 1 in 1000 that the variation in question could be due to sampling errors. The other values are significantly different and show that there is a seasonal change in the size of the organ concerned.

Because the 'Christmas rains' and 'Harmatthan wind' vary in intensity from one year to the next, and because the wet season may end in October or continue into December, the table is strictly a comparison of two monthly means and does

Table 5
Seasonal Variation in Dimensions

		Mean	s(\bar{x})	t
<u>A. compressus</u>				
Culm length	Jan.	27.2	0.3083	3.25
	Oct.	28.7	0.3626	
Culm-sheath	Jan.	8.1	0.1163	4.77
	Oct.	8.9	0.1268	
Culm-leaf	Jan.	6.4	0.0968	9.18
	Oct.	7.7	0.1048	
Spikelet	Jan.	2.1	0.0089	1.40
	Oct.	2.1	0.0109	
<u>A. compressus x flexuosus</u>				
Culm length	Jan.	52.8	0.5263	2.19
	Oct.	51.3	0.4346	
Culm-sheath	Jan.	25.4	0.3014	3.84
	Oct.	23.9	0.2479	
Culm-leaf	Jan.	8.7	0.1867	2.17
	Oct.	8.1	0.2046	
Spikelet	Jan.	2.8	0.0173	7.37
	Oct.	3.0	0.0152	
<u>A. brevipedunculatus</u>				
Culm length	Jan.	18.5	0.2988	13.49
	Oct.	24.3	0.3042	
Culm-sheath	Jan.	10.2	0.1460	13.32
	Oct.	13.6	0.1933	
Culm-leaf	Jan.	3.5	0.1077	16.12
	Oct.	5.8	0.0927	
Spikelet	Jan.	2.5	0.0105	23.58
	Oct.	2.8	0.0020	
<u>A. affinis</u>				
Culm length	Jan.	22.8	0.5192	8.21
	Oct.	27.9	0.3406	
Culm-sheath	Jan.	9.1	0.1392	12.92
	Oct.	11.5	0.1287	
Culm-leaf	Jan.	2.9	0.0818	10.37
	Oct.	3.9	0.0512	
Spikelet	Jan.	1.9	0.0138	4.07
	Oct.	2.0	0.0014	

not necessarily compare the two extremes of seasonal variation.

Significantly different dimensions are shown to occur in the culm-sheath and culm-leaf of A. compressus, the culm-sheath and spikelet length of A. compressus x flexuosus and in all four characters in A. brevipedunculatus and A. affinis.

It would appear from Table 5 that seasonal changes in spikelet lengths of A. compressus and A. compressus x flexuosus are not as great as those induced by differences in habitat conditions. This may indicate that shading may influence spikelet lengths more than water relations.

The spikelet lengths of A. compressus and A. affinis recorded in Tables 2 and 5 deserve comment. In Table 2 these are given as 2.2 mm and 2.3 mm respectively. These dimensions are based upon a single sample taken in October, 1961, at which time A. affinis had just been established in Sierra Leone and was showing very great vigour of growth. In fact, it multiplied so rapidly that it is now being planted in preference to A. compressus. The greater spikelet length of A. affinis may have been due to the increased vigour of plants grown from selected seed under West African conditions but, in comparative terms, it is also due to the West African material of A. compressus having shorter spikelets than West Indian material. The corresponding figures given for spikelet lengths in Table 5 present a different picture. A. compressus there has a spikelet length

of 2.1 mm (based on the combined samples) and A. affinis of 2.0 mm. This suggests that the initial vigour of the latter has ceased (a very common feature in many cultivated plants in Sierra Leone).

Correlation of culm dimensions

A further investigation of the relationship between culm length (the distance between the ultimate node and the apex of the inflorescence, y ,) and the length of the ultimate leaf-sheath, x , is contained in Table 6. From the 1962/63 samples of 20 measurements, taken from the same cultures as in Table 5, a linear relationship, $y = mx + c$, was solved for the constants m and c . The converse relationship, $x = m_1y + c_1$, was also solved for m_1 and c_1 . These solutions were obtained by substitution of the experimental values obtained for $\sum x$, $\sum x^2$, $\sum y$, $\sum y^2$, and $\sum xy$ into the derived relationships, $m\sum x^2 + c\sum x = \sum xy$ and $m\sum x + nc = \sum y$ and the equivalent converse relationships, $m_1\sum y^2 + c_1\sum y = \sum xy$ and $m_1\sum y + n_1c_1 = \sum x$. From the values thus calculated for m and m_1 , the correlation coefficient r was calculated as:-

$$r = \frac{+}{-} \sqrt{m \cdot m_1}$$

As the values of r always fall between +1 and -1 and as a value of zero indicates a complete absence of correlation, the r values provide a numerical index of the uniformity of the relationship between the two linear characters, within each taxon. It can

FIGURE 2.

Spikelets of the seven West African taxa.

The drawings illustrate the comparative sizes and shapes of the spikelets, fertile florets and ovaries. They also compare the hairiness of the spikelets and the size of the apical tuft of hairs on the fertile lemma.

1. A. affinis
2. A. compressus
3. A. brevipedunculatus x compressus
4. A. brevipedunculatus.
5. A. compressus x flexuosus
6. A. flexuosus
7. A. arenosus.



1

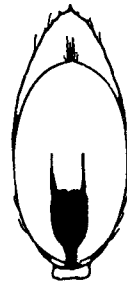

2

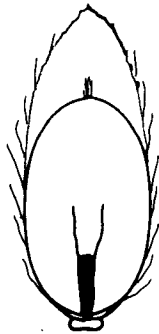

3

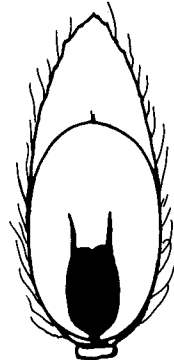

4

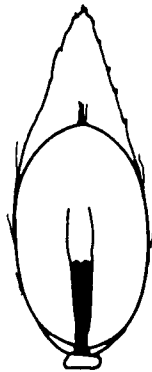

5



6

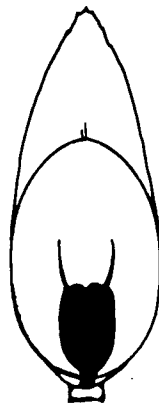

7

FIGURE 2

pedicel in a concavity in the triquetrous rachis. Since these concavities alternate to the left and right of the abaxial margin of the rachis, they confer a sinuous appearance upon it. The lower glume is reduced to an inconspicuous rim, which faces the rachis because of the inverse or adaxial position of the spikelet. The lower floret is reduced to its lemma (the sterile lemma), which resembles the second glume. The upper, fertile floret is hermaphrodite and has subsimilar lemma and palea; the former may or may not have an apical tuft of hairs (see figure 2).

The two lodicules are short, broadly cuneate structures. The three stamens have small anthers, by comparison with the length of the spikelet. The ovary has a bipartite, plumose stigma.

The vascular supply to the spikelet shows no signs of resupination in the pedicel but runs longitudinally inwards, forming a large plexus in the rachilla (see figure 3). From this plexus there diverge supplies to the various organs of the spikelet. Also present in the rachilla is a mass of sclerenchyma at the base of the fertile floret and an abscission layer below the glume and sterile lemma.

No evidence of intergeneric hybridisation was obtained from investigation of spikelet structure. The spikelets of Paspalum differ from those of Axonopus particularly in shape

FIGURE 3.

Arrangement of the parts of the spikelet.

The drawing is of a lateral vertical section. It shows the basal pedicel with two 'wings' which are the sides of the recess in the rachis (r). The vascular supply traverses the abscission layer (shaded) in the base of the rachilla, and forms a plexus (u.p) from which traces pass to the parts of the spikelet. The margins of the upper glume (u.g.) and sterile lemma (s.l) overlap, and so do those of the fertile lemma (f.l) and palea (f.p). There is a layer of fibrous tissue (sc.) at the base of the fertile floret. The lodicules (l.) are notched at the apex. The ovary has two stigmas. The stamens are not shown.

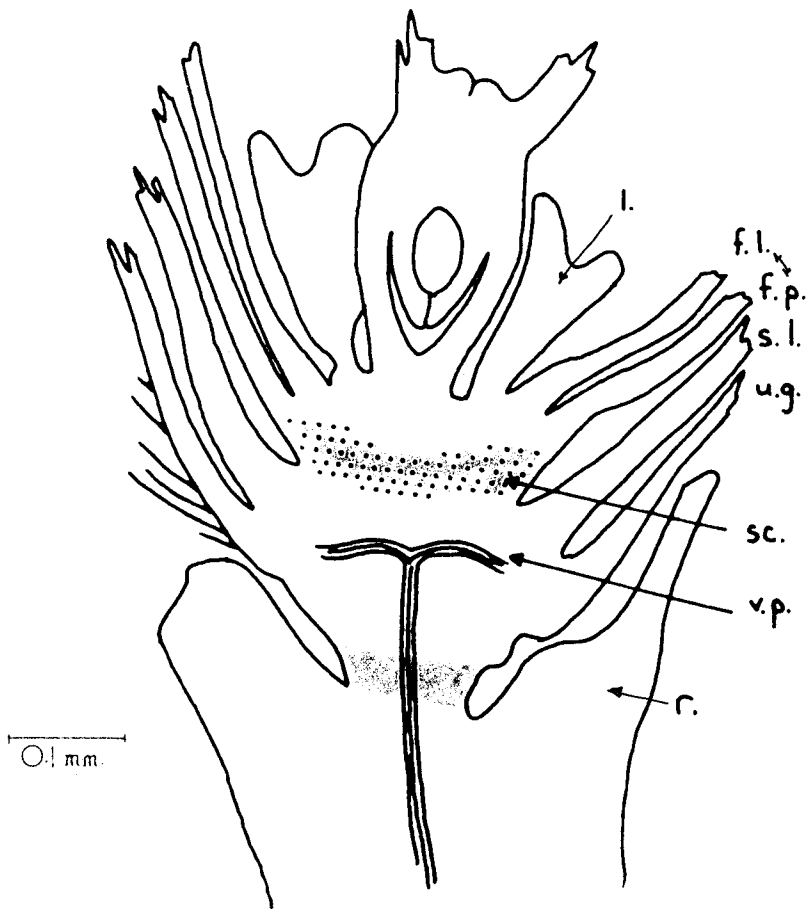

FIGURE 3

(they are orbicular, plano-convex) and by being abaxial.

Differences which were noted in spikelet structure are set out in Table 7. These are in general support of the taxonomy as proposed earlier.

Table 7

Characters of the spikelet and caryopsis

(the taxa are referred to in the same order as earlier)

Glume veins	4-5	5	5-7	5	5	5(-7)	4
Glume hairs	few-many	few	few or none	copious		few	
Glume apex	scattered hyaline teeth					±entire	
Reticulation of lemma	minutely rugose					very finely rugose	
Hair tuft on lemma	conspicuous		reduced		absent or very much reduced		
Fertile floret / glume length	equal	2/3	±2/3	2/3 - 3/4	±2/3	±equal	
Embryo/grain length	1/3	?	±1/2	?	1/2		
	A	B	C	D	E	F	G

Caryopsis and embryo

The taxa differ considerably in the development of the caryopsis; these differences mainly concern the cytology of embryo-sac formation (which is considered later) but there

are also differences in fruit setting and the relative size of the embryo to the caryopsis.

Low fruit setting is characteristic of the two hybrid taxa, A. compressus x flexuosus and A. brevipedunculatus x compressus, and also of destruction by aphids, particularly in A. compressus.

In both A. brevipedunculatus and A. arenosus fruits are formed within spikelets which remain enclosed within the ultimate leaf sheath. This condition is not found in other taxa.

All the caryopses have punctate hila and, in the mature state, are closely embraced by the fertile palea and lemma. The fertile floret remains enclosed by the sterile lemma and second glume and at maturity the whole spikelet disarticulates at the base of the rachilla.

The embryo, in all the taxa, has a deep cleft between the coleorhiza and scutellum and the base of the coleoptile is remote from the point at which the scutellar vascular strand enters the embryo. There is no epiblast. These are all features characteristic of the Panicoid grasses and no variation was noted between the taxa.

Differences in caryopsis structure are also contained in Table 7.

Flowering axis

The abbreviated conical axis, bearing the inflorescences, and the stolons represent two extremes in the development of the aerial stem, in Axonopus. In the former, each inflorescence is produced from the apical meristem and the stem axis elongates from the axil of a reduced leaf (if the entire structure were to be elongated, the condition would resemble that found in many Andropogoneae). The abbreviated axis and its acropetal series of inflorescences is confined within, and derives mechanical support from, the ultimate leaf-sheath (see figure 4, a). The abbreviated axis contains a plexus of anastomosing vascular bundles from which the inflorescences and the reduced leaves receive their supplies. The peduncles of the inflorescences have intercalary meristems, by which they elongate to expose the spikelets beyond the mouth of the leaf-sheath.

The vascular arrangement in the base of the ultimate leaf-sheath consists of alternating large and small bundles, each with a large fibrous supporting sheath which is most pronounced towards the periphery (see figure 4, b). At the sheath margins the fibres alone are present and are situated immediately under the epidermis. At the mid-nerve a number of bundles is grouped towards the periphery. The inner epidermis contains conspicuous opals (opaline silica cells) overlying the mid-nerve region. Opals are not present in the delicate, reduced leaves

FIGURE 4.

The anatomy of the abbreviated conical axis bearing the inflorescences.

In ^a the arrangement of the ultimate leaf-sheath (l.s.) and three peduncles (pi, pii and piii) are shown in vertical section. In b, the arrangement of the ultimate leaf-sheath, first peduncle (pi), first reduced leaf (rli) and conical axis (c.a) are shown in transverse section. Vascular bundles (shaded) are shown in b.

The peduncles are leaf opposed; pi to the leaf-sheath (l.s.), pii to the first reduced leaf (rli), piii to the second reduced leaf (rlii), etc..

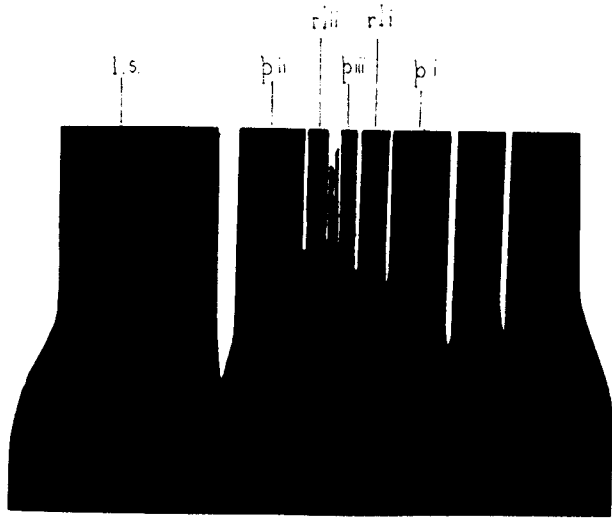

a

0.1 mm.

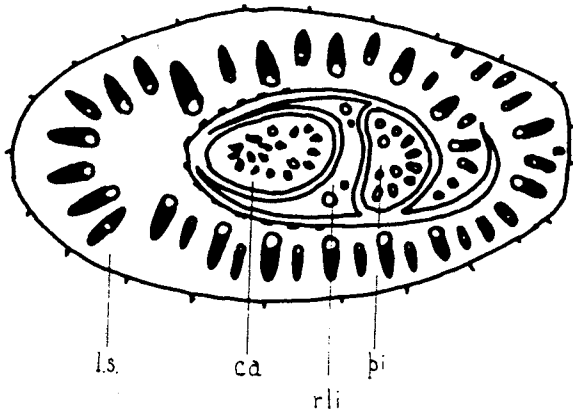

b

FIGURE 4

within the sheath.

The taxa differ in the number of inflorescences which are produced on the abbreviated axis and in the dimensions of this axis and the ultimate node, but neither of these characters is reliable, taxonomically, since each is affected by growing conditions.

Stolon internodes

Unlike the abbreviated axis, the lower part of the flowering stem and the stolons have elongated internodes whose intercalary meristems allow for their elongation and also for their upwards, geniculate curvature (in the case of flowering stems) or downwards, arching curvature (in the case of stolons). In the penultimate internode of the flowering stem this elongation and curvature is accompanied by rupturing of the central parenchyma to give a fistulose structure. This is seldom found to occur in the stolon internodes, except on drying. In all other structural respects these two types of stem are identical and in order to obtain comparable data for this account sections were prepared from the third internode of stolons, above the intercalary meristem.

The stolon internodes have a parenchymatous ground tissue and the peripheral cells of this contain chloroplasts. The central spongy parenchyma consists of enlarged cells and

large intercellular spaces. Only in the most massive stolons of A. flexuosus has the apical portion of this spongy parenchyma been observed to become fistulose before drying out.

Mechanical tissues (figure 5) include a double layer of sub-epidermal collenchyma cells, the bundle sheaths and a band of sclerenchyma which delimits the outer 'cortical' parenchyma from the inner 'medullary' parenchyma.

The individual bundles are arranged somewhat irregularly in three layers; one within the fibre layer and consisting of large bundles, one within or adjacent to the fibre layer and one outside the fibre layer. The innermost bundles are in one to three more or less concentric series. The outermost bundles are small leaf trace bundles and are most conspicuous in the larger stolons, which are relatively more compressed. This suggests that it is a mode of increasing mechanical support.

The bundles have a sheath of small diameter fibres within which the phloem consists of quite large diameter sieve elements and the xylem consists of three radially tiered protoxylem vessels flanked on each side by a single large metaxylem vessel. In the more elongated stolons lysigenous cavities may form near the protoxylem. Fusion of bundles, especially in the region of the fibre layer, results in an amphivasal structure.

The differences in stolon anatomy are summarised in Table 8 and illustrated in figure 5.

FIGURE 5.

Variation in stolon anatomy.

The drawings are of transverse sections of the third (antepenultimate) internode, above the intercalary meristem.

The most obvious differences are those of size, the arrangement of the vascular bundles, and the width of the fibrous band (Sc.).

- a. A. arenosus
- b. A. brevipedunculatus
- c. A. affinis
- d. A. compressus
- e. A. flexuosus.

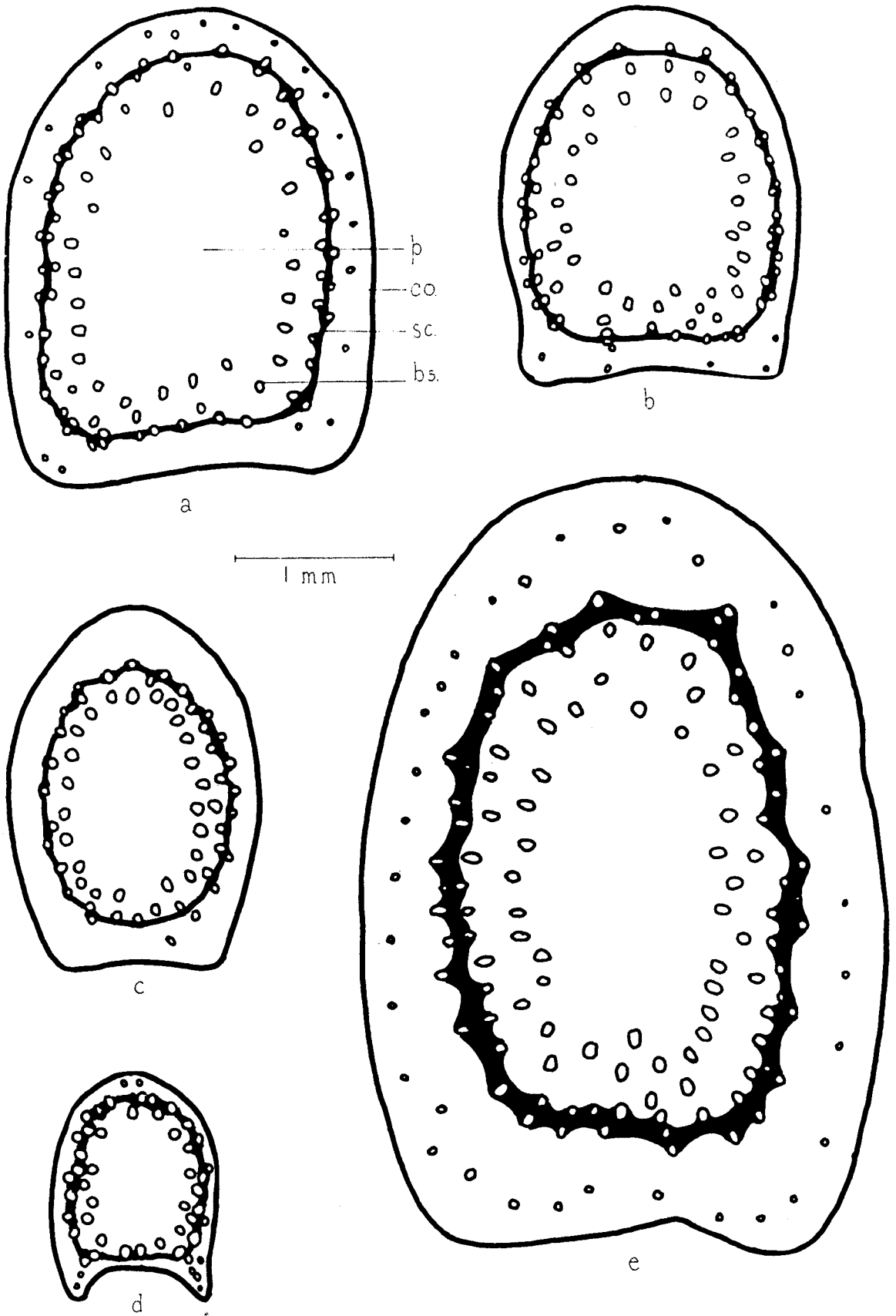

FIGURE 5

Table 8

Differences in stolon structure

(The numbers represent increasing orders of conspicuousness.

The taxa are referred to in the same order as earlier.)

Size in TS	2	5	7	4	3	6	1
Keeling	7	6	2	5	4	3	1
Fibre layer	2	1	3	1	1	1	1
Bundles in fibrous layer	3	1	1	1	2	1	3
	A	B	C	D	E	F	G

Figure 5 shows diagrammatically the arrangement of the bundles and fibre layers in A. compressus (d), A. arenosus (a), A. flexuosus (e), A. brevipedunculatus (b) and A. affinis (e).

It can be seen that the width of the fibrous layer is accentuated by the juxtaposition of bundles and is most conspicuous in A. flexuosus and A. compressus. The small number of leaf trace bundles in A. compressus and A. affinis suggests that in these two species the traces remain associated with the fibrous layer instead of running outwards into the outer parenchyma as in the other species.

The stolon internode is the equivalent of the peduncle in ontogenetic terms. The development of the peduncles, however, is definite and leads to the production of the racemes. That of the stolon is indefinite in so far as each internode forms

FIGURE 6.

SEEDLINGS OF A.COMPRESSUS

- a. The coleorhiza penetrates the fertile lemma and glume before the radicle emerges. The coleoptile attains a length of about 4mm, before it is ruptured by the first leaf.
- b. The first leaf is initially inrolled and erect, but expands and becomes inclined at an angle of 45° , or less, as it matures.

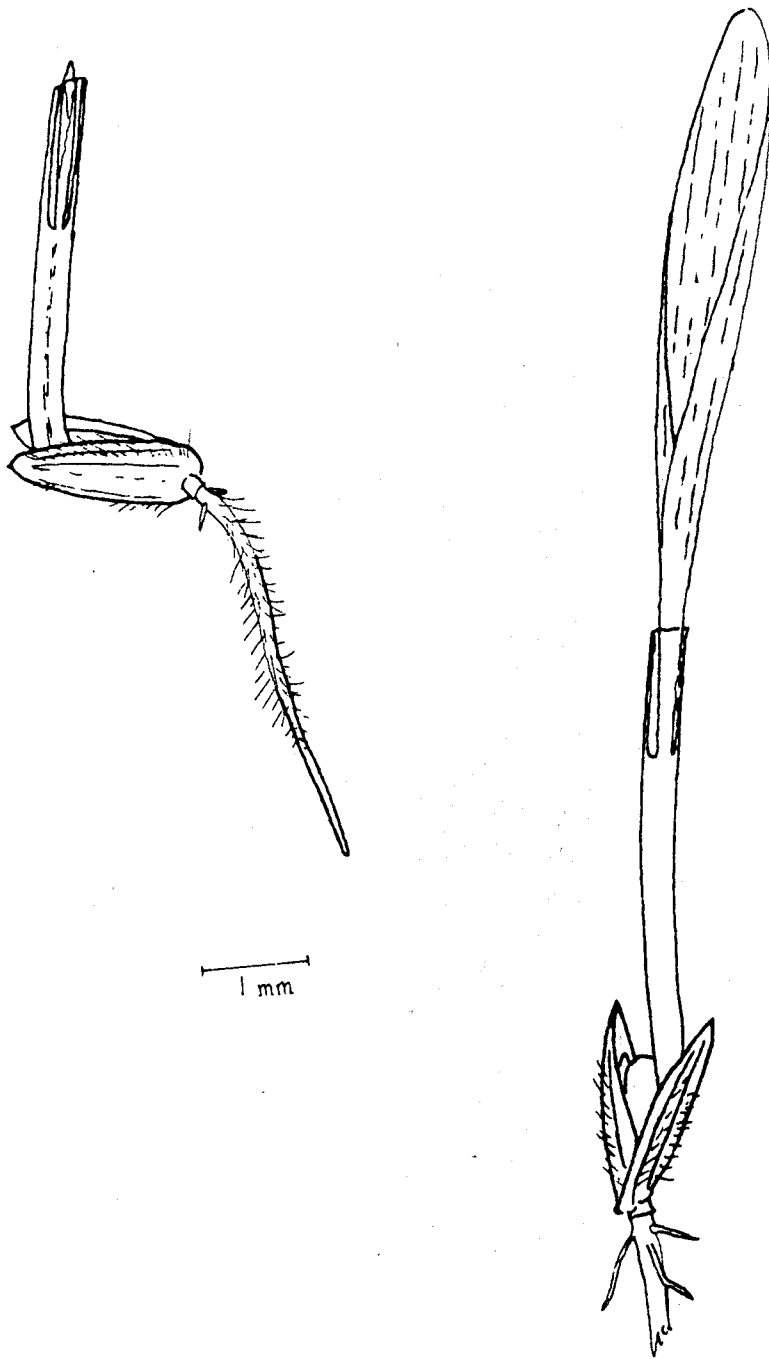

FIGURE 6

as a consequence of the activity of the apical meristem and this process is repetitive. The innovations, like the abbreviated axis of the culm, is axillary but unlike the abbreviated axis an innovation may give rise to a lateral stolon and so exhibit further indefinite growth. This last is commonly found in A. compressus, A. arenosus, A. brevipedunculatus, A. brevipedunculatus x compressus and A. affinis. In A. flexuosus the high arching stolons have up to 4 very long internodes and the lower nodes do not come into contact with the soil. The innovations at these lower internodes produce branches from which one to several flowering shoots may arise. The apex of the stolon produces a terminal flowering shoot and sometimes also a number of extravaginal ones. The hybrid A. compressus x flexuosus also produces extravaginal flowering shoots.

The leaf

The first leaf of the seedling ruptures the coleoptile when the latter is some 4 mm in length, in dish germinated seeds. The leaf is initially inrolled but expands to about 9 mm in length and 2 mm in width (see figure 6). It becomes inclined at an angle of 45° , or less, to the horizontal. Being broad, relative to the length, and spreading are both Panicoid features.

The epidermis of grass leaves is characterised by

FIGURE 7.

Variation in the form of leaf epidermal cell opals.

- A. The range of form of the siliceous bodies found in the leaf epidermis of A.compressus. Top row:- plan views of dumb-bell, two forms of tri-partite, and cruciform opals. Second row :- profile of dumb-bell opal (left), and a siliceous plate from an intercostal cell.
- B. Plan and profile views of dumb-bell opal from A.brevipedunculatus.
- C. Plan and profile views of tripartite and dumb-bell opals from A.flexuosus.
- D. Plan and profile views of dumb-bell opal from A.arenosus.
- E. Plan and profile views of dumb-bell opal from A.affinis.

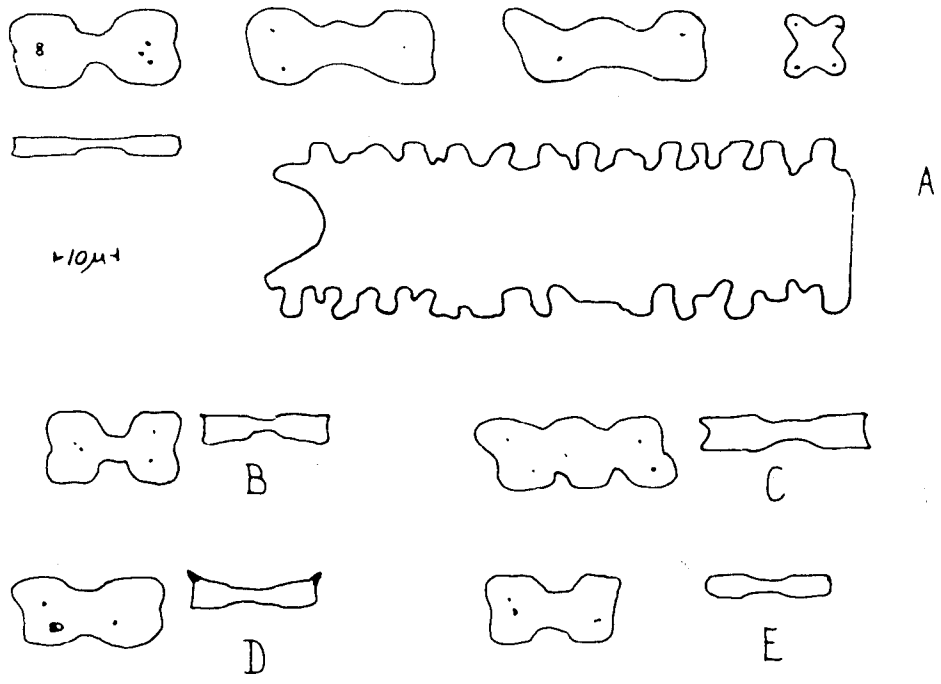

FIGURE 7

FIGURE 8.

CHARACTERS OF THE LEAF EPIDERMIS.

- a. Opaline silica cells in the epidermis above one of the larger subsidiary leaf veins (above) and cruciform opals in epidermal cells above a small vein. One stomum is shown in the intercostal region, with triangular subsidiary cells.
- b. Two examples of short hairs from the leaf margin.
- c. Orbicular base of an epidermal hair, sunk beneath the level of the epidermal cells.

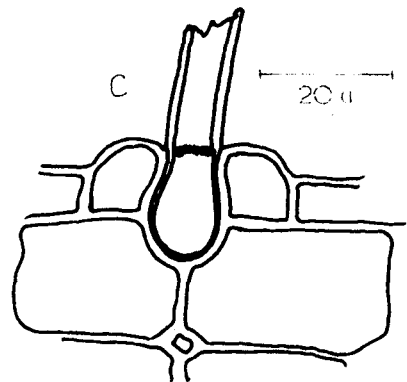
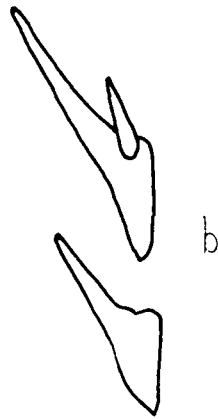
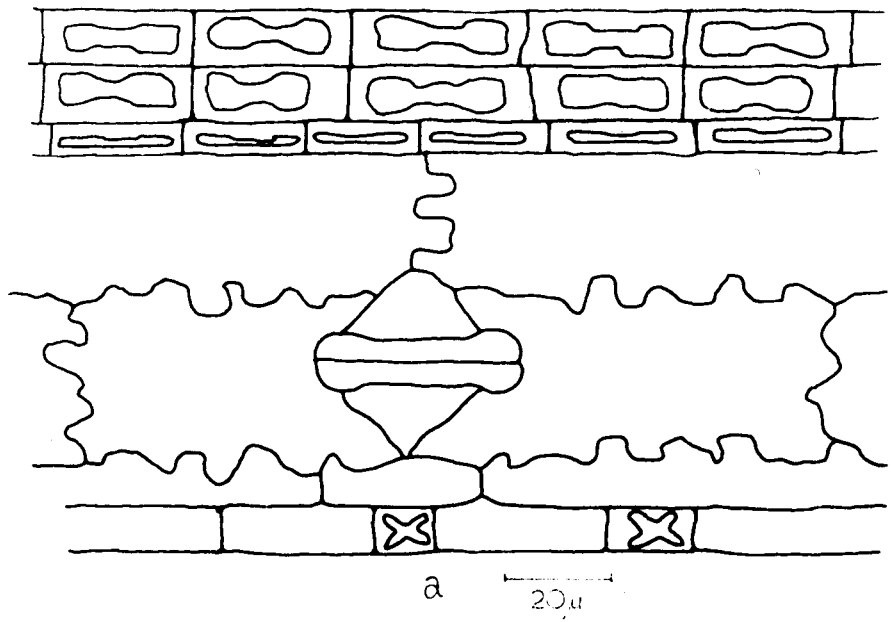

FIGURE 8

having some cells with siliceous contents. These opaline silica cells are short costal cells in which the opals, or silica bodies, are dumb-bell shaped or abbreviated to a cruciform shape or slightly elongated to a tripartite, nodular shape. The range of variation in opal shape is illustrated in figure 7.

The opals are produced in 3 to 5 rows over and below the larger veins and in single rows over and below the subsidiary veins (figures 8, a and 9). The intercostal long cells have sinuous walls, those between the stomata being quite short and having concave ends (figure 8, a). Macro-hairs, when present, have sunken orbicular bases and are thick walled and tapering (figure 8, c). Stomata are superficial and have triangular subsidiary cells.

The general structure of the leaf, as seen in transverse section, is shown in figure 9. The numerous vascular bundles are not conspicuously angular. The smaller bundles consist of an inner (fibrous) sheath of as few as four sclerenchyma cells, no distinct outer sheath, few tracheids and little phloem. The larger bundles have a single inner sheath (is), an indistinct outer sheath layer, intravascular fibres (if) between the fairly copious phloem and xylem and blocks of narrow diameter fibres, or girder sclerenchyma (g) either between the bundle sheath and the lower epidermis or between the sheath and both the upper and lower epidermis. The term girder is applied

FIGURE 9.

VARIATION IN LEAF ANATOMY

1. General structure, as seen in transverse section in the region of a large subsidiary vein. HC, hinge cells of the upper epidermis. LS, single inner sheath of vascular bundle. G, girder sclerenchyma above subsidiary bundle. O, opaline silica cells. IF, intravascular fibres. M, mesophyll.
2. Median region of A.brevipedunculatus, showing adaxial girder (hatched) median vascular bundle (solid) and abaxial hinge cells.
3. Median nerve region of A.flexuosus, showing deep V-shaped appearance of hinge cells.
4. Median nerve region of A.arenosus showing shallow V-shaped appearance of hinge cells.

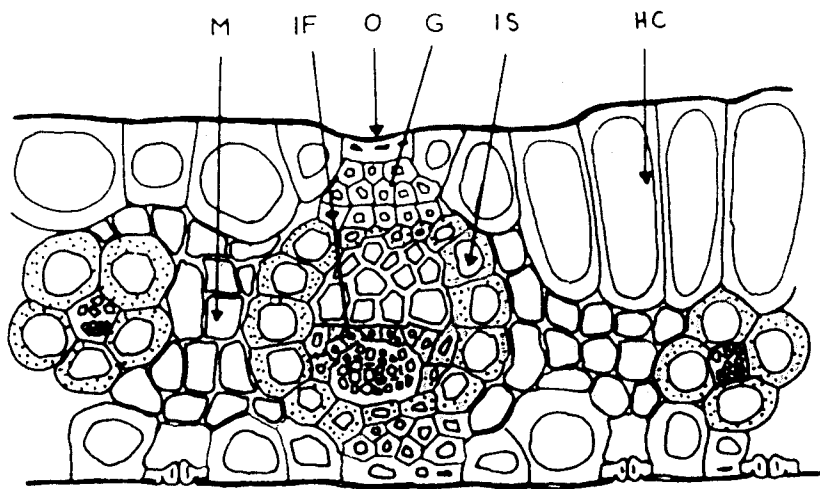

1

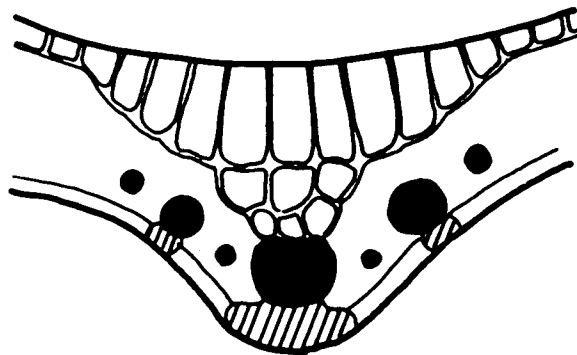

2

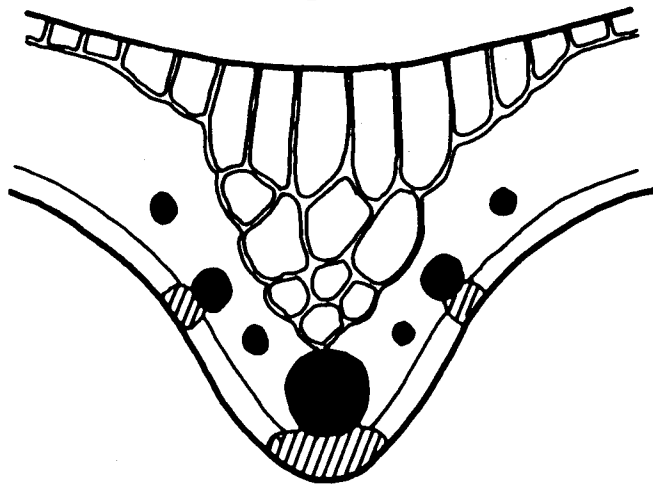

3

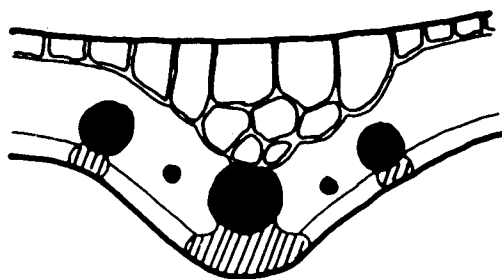

4

0.2 mm

FIGURE 9

because of the resemblance between these fibrous structures and the web of a girder. The principal bundles have large abaxial girders but the adaxial ones are replaced by groups of large hinge-cells (hc), the collapse of which results in the lengthwise folding of the leaves on drying. The median keel is conspicuous with a single abaxially girdered bundle and two or three subsidiary bundles laterally. The hinge cells above the median nerve show differences in the several taxa and some of these are illustrated in figure 9.

The mesophyll has an incipient palisade structure (figure 9, m) adaxially to the smaller bundles but is otherwise semi-radial. Apart from depressions over the principal nerves, the upper epidermis is smooth. When present, hairs have their bulbous bases sunken in the epidermis of the intercostal bands. The lower epidermis is smooth.

Hairs on the leaf margins (figure 8, b) are either long and tapering, from a sunken orbicular base, or are short and slightly curved, from the two rows of thickened marginal cells. These latter are supported by two submarginal rows also consisting of thick walled cells.

The main anatomical differences in leaf structures are summarised in Table 9.

Table 9

Leaf anatomy

(The main features which distinguish a taxon, only, are presented. The taxa are referred to in the same order as earlier.)

Opals			thicker in profile			horned in profile	many cruciform
Girders							most pro- nounced
Hinge cells			large, in deep V			rounded shallow V	
Mesophyll							least pallisade like
Epidermal hairs			none		most copious	few	none
Marginal long hairs		few	few or none				few widely spaced
Marginal short hairs (teeth)			most pro- nounced				
	A	B	C	D	E	F	G

The root

The young root has a uniform epidermal layer of elongated cells. Root hairs arise centrally from these. In transverse section the epidermal cells are slightly elongated radially and their radial and inner walls are thickened. The outer cor-

tical parenchyma is composed of isodiametric cells towards the outside and tiers of trapezoidal cells towards the centre. No distinct endodermal layer is evident in the young root. The inner parenchyma is spongy and envelopes up to twenty primary vascular elements.

Root hairs persist throughout most of the length of old roots and only after the formation of a four cell thick layer of fibre in the outermost cortex are the piliferous and hypodermal layers sloughed off. Within the fibrous layer the cortex becomes lacunar towards the outside (figure 10) and the trabecular portions often collapse. The endodermis of older roots is well developed and has very thick inner and radial walls. Within the endodermis the stelar region develops as a fibrous ground tissue within which about ten metaxylem elements can be detected (the number varies with the size of the root). The centrifugal protoxylem is compressed and difficult to distinguish from the fibre. Phloem groups are more numerous than metaxylem elements; usually about three times as numerous.

Since no variation in root anatomy has been detected, which was not related to root size, and since size variation in a single plant is considerable, no value can be attributed to root anatomy as a taxonomic criterion within this group. It is of interest, however, that the numerical relationship between phloem and xylem groups has not been noted by Metcalfe (1960)

FIGURE 10.

1. Transverse section of young root. Beneath the piliferous layer, the outer cortical parenchyma (oc) is composed of isodiametric cells, and the inner cortical parenchyma is composed of radially tiered cells. The primary vascular elements (px) are shown, shaded.
2. Transverse section of an old root. The root hairs (rh) persist for some time, after the formation of the fibrous layer (f) in the outer cortex. Within the fibrous layer, the cortex becomes lacunar(l). Within the endodermis (e) the stelar region has a fibrous ground tissue, in which are shown eight metaxylem elements.

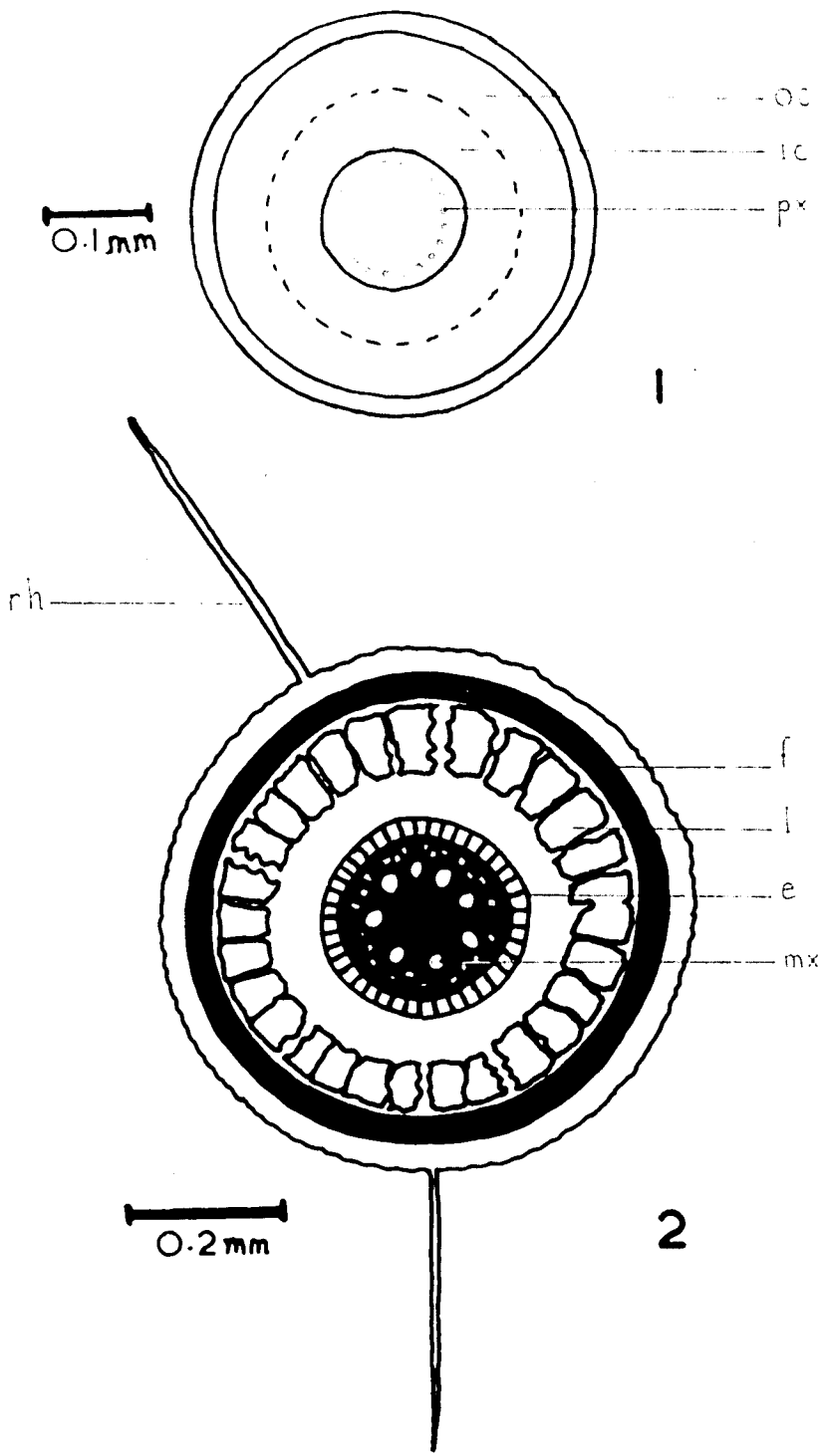

FIGURE 10

in his treatise on the anatomy of the grasses; especially as this feature is to be seen in both Paspalum conjugatum and P. commersonii, the latter being described in some detail by Metcalfe. It is clear that large metaxylem elements do not form in every primary xylem group. This lack of differentiation and the copious formation of sclerenchyma may account for the apparent discrepancy.

A number of anatomical differences are of taxonomic importance.

The relative lengths of the fertile floret and the glume, although affected by environmental changes in overall spikelet length as described earlier, permit the recognition of A. compressus and A. affinis (in both of which the fertile floret almost equals the glume in length) as distinct from the other taxa (in which the glume is considerably longer than the fertile floret). The glume apex of A. affinis is entire or, at the most, only slightly irregular at the margin. All the other taxa have minute hyaline teeth on the margin of the glume apex. These are minute in A. compressus, and have the appearance in A. flexuosus and A. arenosus of irregular lacinations. The apical tuft of hairs on the fertile lemma is inconspicuous in A. brevipedunculatus and mostly lacking entirely in A. arenosus

and A. affinis. The nerves of the glume distinguish A. flexuosus, although A. arenosus may have a similar nerve arrangement.

The length of stolon internodes has already been discussed. The anatomy of these provides the distinguishing features of the large amount of sclerenchyma in A. flexuosus and the most pronounced keeling in A. compressus.

All the taxa show much variety in the form of the opals of the leaf epidermis. A. flexuosus has thicker opals than any of the other taxa and A. arenosus opals appear to have extended upper margins, when seen in profile, which give them a horned appearance. The large hinge-cell region of the leaf, above the mid-nerve, is most extensive in A. flexuosus and is least pronounced in A. arenosus and A. affinis. This agrees with the observations on wilting behaviour in these taxa.

The evidence obtained from the anatomical investigations supports the taxonomic proposals.

Cytological variation

Within the Paniceae the basic chromosome number for the genera Oplismenus, Leptocoryphium, Isachne, Paspalum, some species of Urochloa, Stenotaphrum, many species of Panicum is 10, and this is apparently the case in some species of Axonopus and several other grass tribes. Records of the chromosome numbers of species of Axonopus include the following:-

A. argentinus Parodi	n=15	Parodi, 1938.
.. var. genuinus	n=18	..
.. var. glabriflorus	n=19	..
.. var. glabripes	n=19	..
.. var. hirsutus	n=18	..
A. hagenbachianus (O.Kze) Parodi	n=21	..
A. longicilius (Hackel) Parodi	n=22	..
A. pressus (Nees) Parodi	n=23	..
A. suffultus (Mik) Parodi	n=23	..
..	2n=40	DeWet & Anderson, 1956.
.. var. pubiflorus	n=23	Parodi, 1938.
A. scoparius (Flügge) Hitch.	2n=20	Dedecca, 1956.
A. iridaceus (Mez) Hitch.	2n=20	Nunez, in Parodi, 1946.
..	2n=20	Delay, 1950.
A. compressus (Sw.) Beauv.	2n=40	Janaki-Amal, 1945.
..	2n=56-60	Nunez, in Parodi, 1946.
..	2n=40,50,60	Delay, 1950.
A. furcatus (Flügge) Hitch.	2n=40	Brown, 1950.

A. affinis Chase 2n=80 Burton, 1942.

.. 2n=80 Brown, 1948.

Carnahan and Hill, 1961, recorded the diploid number of *A. affinis* as 54, but this apparently was due to a card indexing error by those authors (personal communication).

Materials and methods

For the examination of somatic chromosome numbers, actively growing culms were selected at random from the experimental beds and cultured in Bristol's solution (Peacock, 1940). The roots selected for examination were the newly developing adventitious roots of up to 1 cm length and 0.5 mm diameter. Roots of these dimensions were found to have more cells in division and to have larger cells than roots of greater or lesser length. Cell division was found to be most active during the night and the culms were transferred to a solution of a-mono-bromo-naphthalene at 8.0 p.m., in which they were kept at 12°C. for two to three hours. This was found to inhibit spindle formation and to prevent the clumping of the chromosomes, which is a common feature in grasses. Fixation was allowed to proceed overnight at -6°C. in 70% alcohol in 1% lactic acid (Jacobsen, 1954). This fixation gives material which squashes easily and so allows the wide separation of the chromosomes.

Synthetic Orcein (LaCour, 1941) was found to give good staining but tended to differentiate less well than iron-aceto-

carmine.

A number of transverse sections was prepared by wax impregnation through a tertiary butyl alcohol series, sectioning, and staining with Lugol's iodine and crystal violet. There were found to be less useful than the squashes for chromosome number determination. Meiotic chromosome behaviour was examined by preparing anther squashes. Young anthers were dissected out of the spikelets on inflorescences which were still confined within the ultimate leaf-sheath. This was done at 8.0 a.m. and the anthers were fixed for 24 hours in the alcohol/lactic acid medium. It was found possible to store the anthers at -6°C . for several weeks. Microsporogenesis was investigated by splitting the anthers by hand, under a binocular microscope, and then proceeding as with a root-tip squash, using iron-aceto-carmin.

In the following account of the cytological findings, the taxa are dealt with individually and the meiotic behaviour during microsporogenesis is expressed in the tables as chromosome configurations at diakinesis. Thus, bracketed figures indicate the occasional observation of a particular association (iv = quadrivalent, iii = trivalent, ii = bivalent, i = univalent) and 'multivalents' signifies highly irregular behaviour in which the chromosomes associated in a complex mass and had the appearance of being 'sticky', due to numerous attenuated

interconnections.

Table 10

A. compressus

Material	Somatic number	Microsporogenesis			
		iv	iii	ii	i
101	40(-42)	-	-	20	(-2)
102	40	-	-	20	-
103	40(-44)	(-1)	-	20	(-4)
104	40	-	-	20	-
105	40	-	-	20	-
106	40	-	-	20	-
107	40(-44)	(-1)	-	20	(-4)
108	40	-	-	20	-
109	40	-	-	20	-
110	40	-	-	20	-
111	40	-	-	20	-

(Figures 11, a and b are of preparations made from 102.)

The somatic chromosome counts show a uniformity which serves to confirm the morphological delimitation of the species. The higher somatic counts (bracketed figures for 101, 103 and 107) were found in only a few of the roots examined.

Some difficulty was found in obtaining a satisfactory dispersal of the chromosomes and cells were frequently burst. Since this bursting raised the possibility of losing chromosomes

FIGURE 11.

A.compressus. a. Root-tip squash, pretreated with α -mono-bromo naphthalene, showing 40 chromosomes, of which one pair (arrowed) have conspicuous trabants.

b. P.M.C. at diakinesis, showing 20 bivalents and a single nucleolus.

(Phase contrast photomicrographs.)

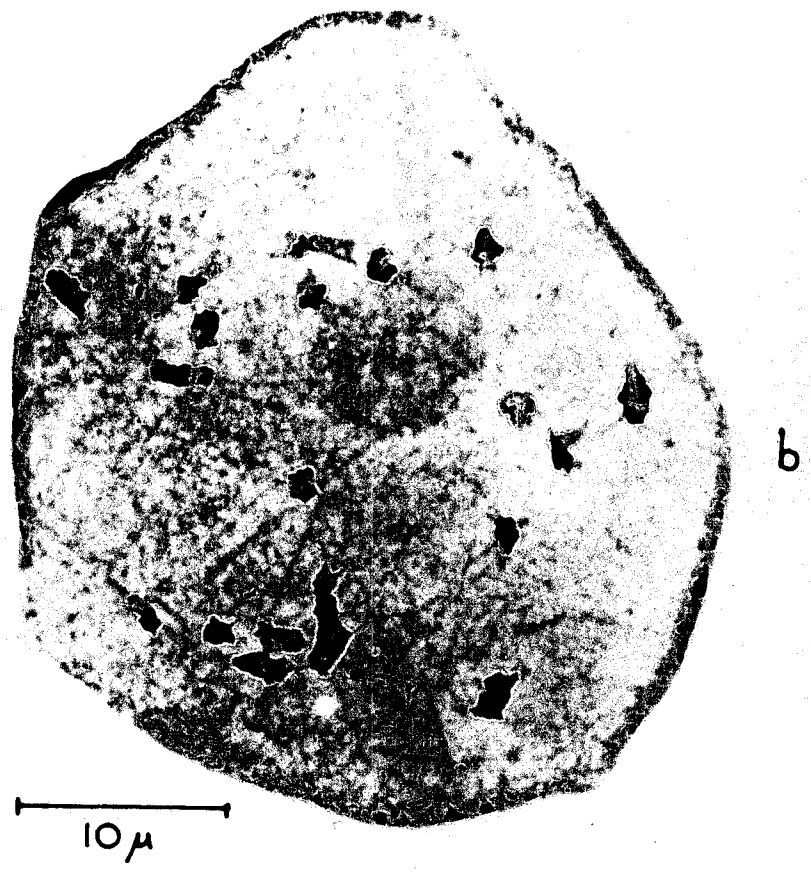
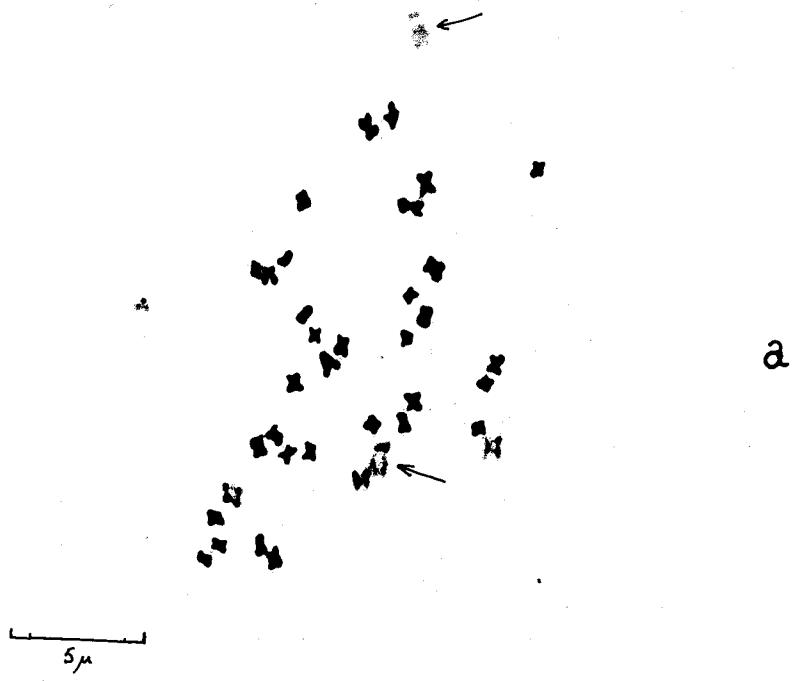

FIGURE II

burst cells were disregarded and the certain counts of $2n=40$ (see figure 11, a) were made on intact cells. These show one homologous pair of chromosomes with conspicuous trabants (arrowed in the figure) and it may be that it is the rupturing of these which gives rise to the occasional appearance of two additional chromosomes. Since, however, the evidence of the meiotic counts shows that, in the same materials which occasionally gave somatic counts greater than 40, additional univalents or tetravalents were occasionally observed, it may be assumed that additional or B-chromosomes are present in some plants of this species. The quadrivalents recorded, in 103 and 107, might result from secondary association which is known to occur between B-chromosomes, and also between fragments, because of their remote homology. The association supports the view that A. compressus should be regarded as tetraploid.

It must be mentioned, however, that the small chromosomes of these grasses (the longest bivalent in figure 11, b is less than 3.8 microns) are difficult to interpret when superimposed and that the interpretation as a quadrivalent may be incorrect.

FIGURE 12.

A. flexuosus a. Root-tip squash, pretreated with a-mono-
bromo naphthalene, showing 60 chromosomes.

 b. P.M.C., first anaphase, showing normal
reduction.

(Phase contrast photomicrographs).

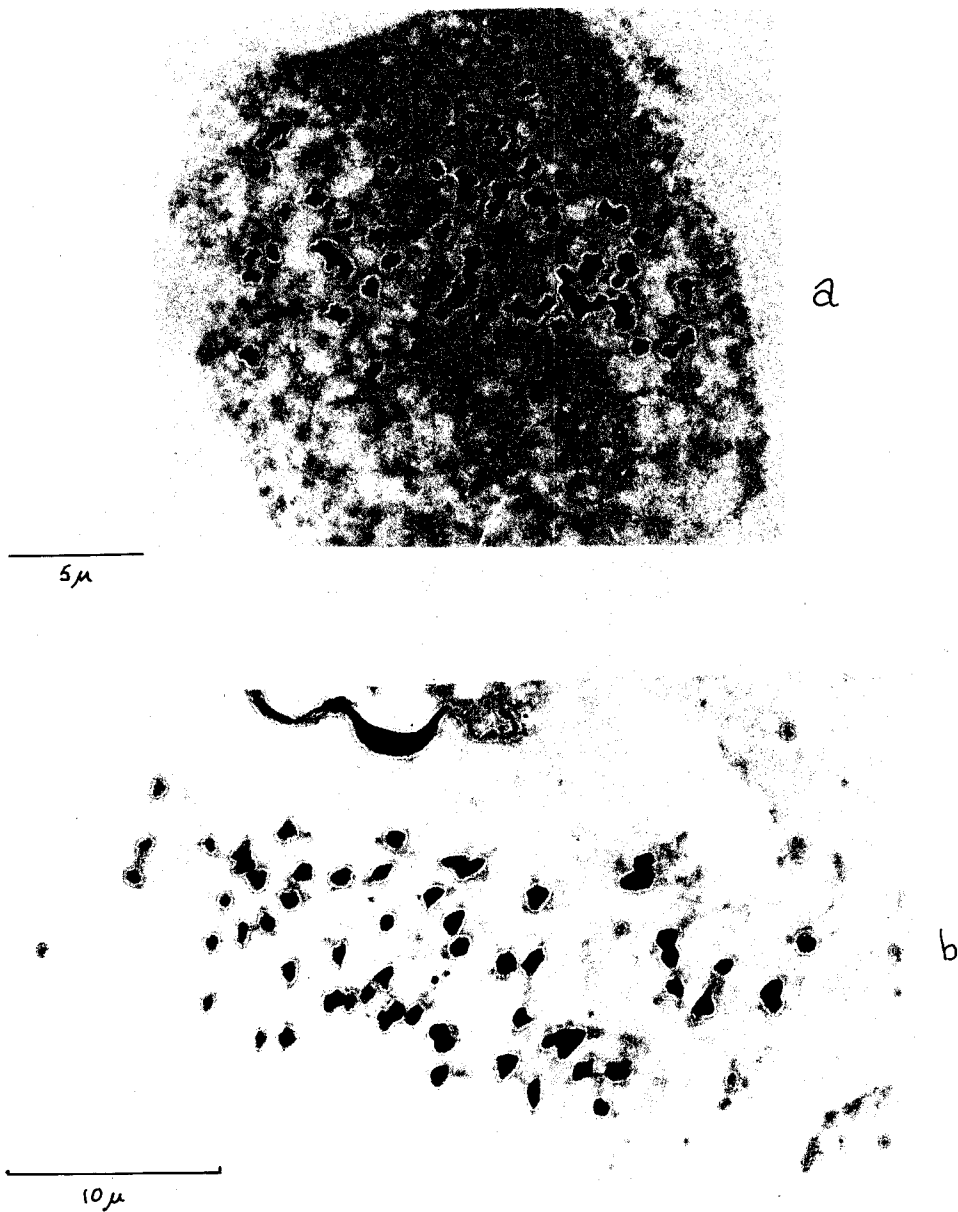

FIGURE 12

Table 11

A. flexuosus

Material	Somatic number	Microsporogenesis			
		iv	iii	ii	i
203	60	-	-	30	-
205	60	-	-	30	-
206	60	-	-	30	-
207	60	-	-	30	-

(Figures 12, a and b are from preparations made from 206.)

The somatic counts serve to confirm the morphological recognition of this species. The somatic counts are confirmed by the regular meiotic formation of 30 bivalents. The regularity of the meiotic behaviour suggests an allopolyploid constitution. The species may be regarded as a hexaploid, derived from the amphidiploid, A. compressus, but this will be considered in greater detail in a later section.

Table 12

A. compressus x flexuosus

Material	Somatic number	Microsporogenesis			
		iv	iii	ii	i
201	48-54	3-4	(1)	17-19	(4)
202	50-54	multivalents			
204	50	multivalents			

(Figures 13, a and b are from preparations made from 201.)

FIGURE 13.

A. compressus x flexuosus. a. Root-tip squash, pretreated with α -monobromo naphthalene, showing 54 chromosomes.

b. P .M.C. at diakinesis, showing 'stickiness' of chromosomes and a single nucleolus.
(Phase contrast photomicrographs).

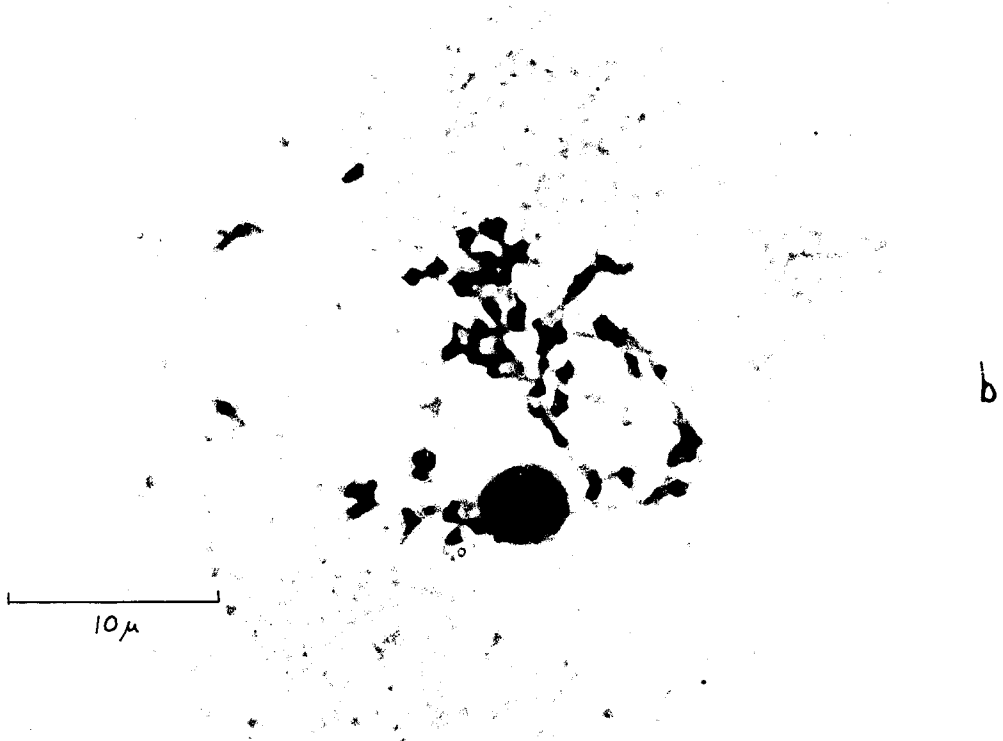

FIGURE 13

The somatic counts support the view that these materials are hybrid. The habitat of the 204 material is not known but the somatic complement suggests formation of the hybrid by union of $x = 20$ and $x = 30$ gametes. This might also be the case in the 201 and 202 materials which, in addition, have accumulated up to four additional chromosomes. The 201 material also suggests that chromosome losses might have followed such a hybridising process. No $2n = 60$ material has been detected in the original habitat of the 201 material, however, so that it appears more likely that they have resulted from a union between gametes both of which carried extra chromosomes. This would greatly depend upon both the gametes being functional and also upon either the previous accumulation of additional chromosomes or an irregular first division segregation in both mega- and microsporogenesis. An alternative explanation might be that these higher chromosome numbers have arisen by the somatic accumulation of additional chromosomes alone. This would be facilitated in a closed turf, under conditions favouring all the year active growth, by the strongly vegetative growth of these grasses. Clonal individuals formed thus would differ in somatic number and would tend to exclude seedlings, by physical competition. Seedlings would subsequently become less frequent due to the chromosome conditions causing increased meiotic irregularity.

FIGURE 14.

A. brevipedunculatus. a. Root-tip squash, pretreated.
with α -monobromo naphthalene, showing 40 chromosomes.

 b. P.M.C. at diakinesis, showing
20 bivalents and two nucleoli (one much smaller than the
other).

(Phase contrast photomicrographs).

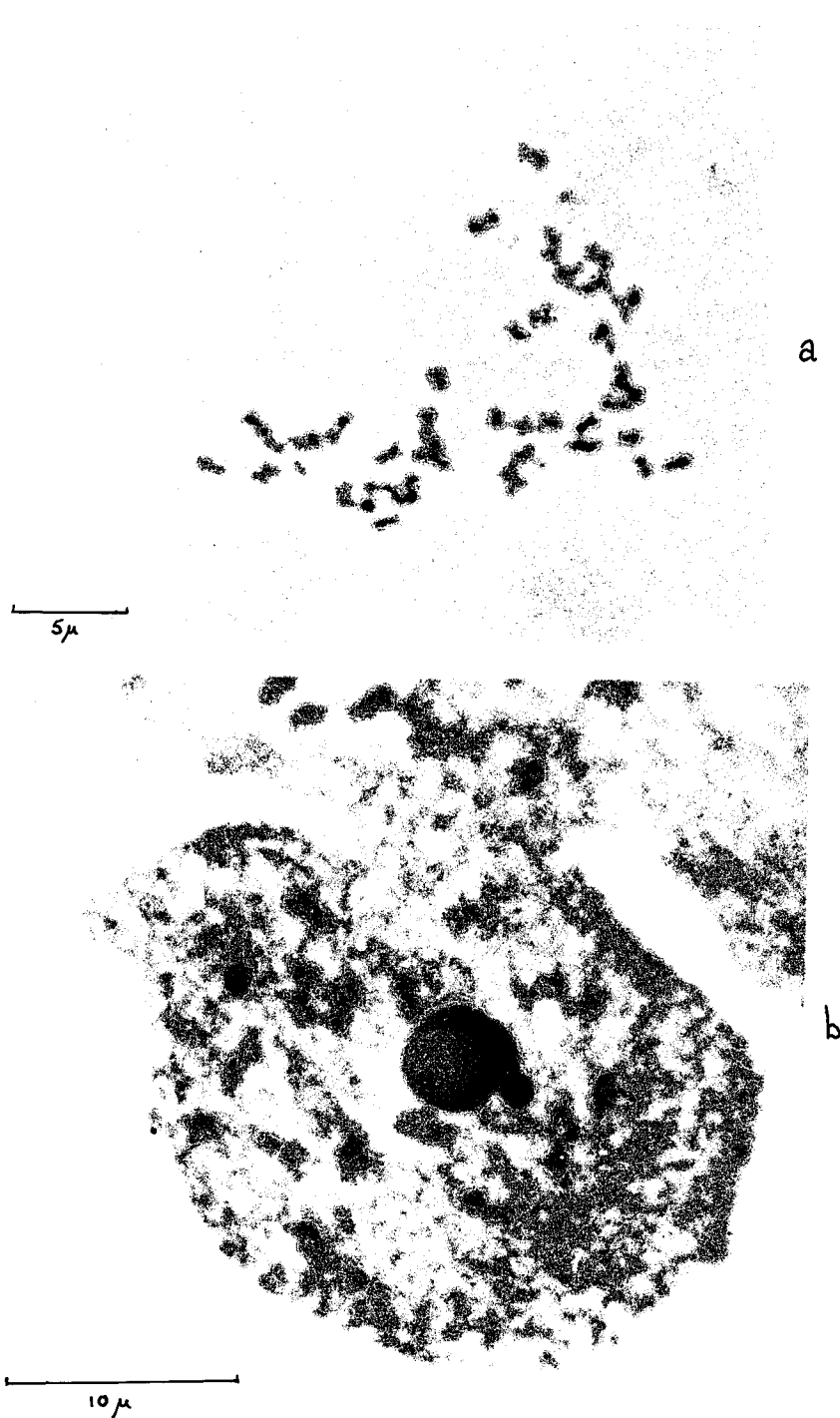

FIGURE 14

All these materials are approximately pentaploid and are to be expected to show both meiotic irregularity and infertility. It is of interest to note that, in 201, tetravalents are formed rather than univalents and that in all the materials there is a great amount of homology which leads to the formation of multiple chromosome configurations rather than of bivalents. These points will be discussed later.

Table 13

A. brevipedunculatus

Material	Somatic number	Microsporogenesis			
		iv	iii	ii	i
302	40	-	-	20	-
306	40	-	-	20	-
307	40(-42)	-	-	20	(-2)

(Figures 14, a and b, are from preparations made from 302.)

These materials are cytologically similar to A. compressus. The occasionally recorded somatic number of 42 could be again regarded as being due to acentric fragments and this appears to be confirmed by the occasional observation of two 'univalents' during microsporogenesis, but it is equally probable that the two extra chromosomes are B-chromosomes, and this is the more likely explanation.

FIGURE 15.

A.brevipedunculatus x compressus.

a. Root-tip squash, showing 40 chromosomes. Pretreated with α -monobromo naphthalene. The darkest mark at the left is an artefact.

b. P.M.C. at diakinesis, showing 14 bivalents (16 were distinguishable in the preparation), a trivalent (iii), a quadrivalent (iv) and a univalent (i). Two nucleoli are also visible.

(Phase contrast photomicrographs)

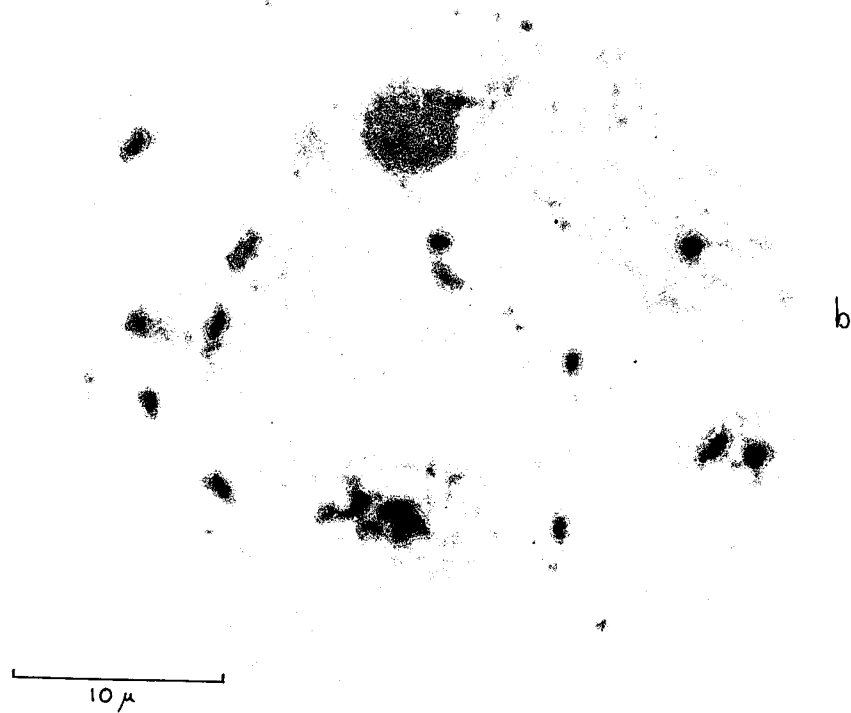

FIGURE 15

Table 14

A. brevipedunculatus x compressus

Material	Somatic number	Microsporogenesis			
		iv	iii	ii	i
301	40	(1)	(1-3)	16-20	(5)
303	40	(1)	-	14-19	(8)
305	40	multivalents			

(Figures 15, a and b, are from preparations made from 301.)

The somatic counts support the view that these materials are hybrid. The materials are all from transitional habitats in which populations of both putative parent species occur side by side and are subject to disturbances by man.

The meiotic configurations suggest that there is considerable homology between the genomes of the two parental species. The formation of multiple chromosome configurations may be due to small differences in parental genome structures, such as inversions and interchanges, but it has not been found possible to interpret them precisely.

Table 15

A. arenosus

Material	Somatic number	Microsporogenesis			
		iv	iii	ii	i
304	60	-	-	30	-
308	60	-	-	30	-

(Figures 16, a and b, are from preparations made from 308.)

FIGURE 16.

A.arenosus. a. Root-tip squash, pretreated with acenaphthylene, showing 60 chromosomes.

b. P.M.C. at diakinesis, showing 30 bivalents.

(Phase contrast photomicrographs).

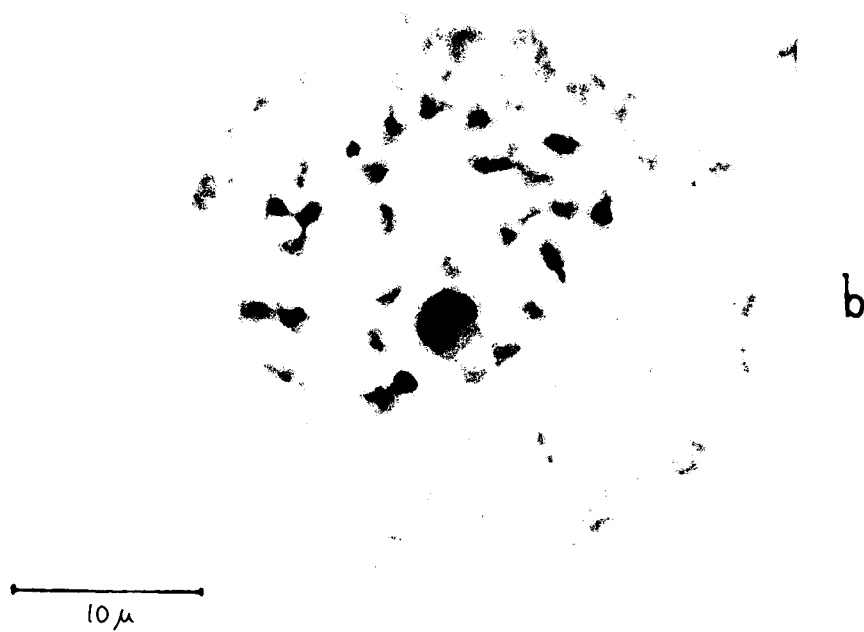

FIGURE 16

The somatic chromosome counts serve to confirm the distinction between this species and A. brevipedunculatus, and also show A. arenosus to be hexaploid. As for A. flexuosus, the regularity of pairing suggests allopolyploidy.

Table 16

A. affinis

Material	Somatic number	Microsporogenesis			
		iv	iii	ii	i
401	80	-	-	40	-
402	80	-	-	40	-

(Figures 17, a and b, are from preparations made from 401.)

The somatic counts confirm the morphological delimitation of this species and also show it to be octoploid.

The cytological evidence will be discussed in the last chapter when it will be assessed in the light of the additional information obtained from the examination of artificial hybrids and of current views arising from other workers' findings on other plants.

FIGURE 17.

A.affinis. a. Root-tip squash, pretreated with
a-monobromo naphthalene, showing 80 chromosomes.

b. P.M.C. at diakinesis, showing 40
bivalents.

(Phase contrast photomicrographs).



FIGURE 17

Reproduction and breeding mechanisms

Vegetative reproduction

It has been seen that all the taxa under consideration have rhizomes and stolons, and that there are differences in the size and behaviour of the latter. In all the taxa, ecological success against other competing species is largely dependent upon the efficiency of stoloniferous growth. Thus A. compressus, A. brevipedunculatus and A. affinis produce numerous many-noded stolons with short internodes when grown on open ground, where ephemerals provide the main competition, and A. flexuosus has few-noded stolons with long internodes, which enable it to compete with the taller competitors in the herbaceous margins of riparian forest. In most regions of West Africa, the climax vegetation is composed of very tall plants (the various forest and thicket communities) or is too arid to support herbaceous perennials such as Axonopus. The competitive ability of Axonopus appears at its most efficient in biotically disturbed or controlled habitats, where the disturbance or control has been directed against woody growth but has not been so drastic as to produce drier, savanna-like areas.

Stoloniferous growth provides for the rapid covering of open soil surfaces and, if competition from other species is to be overcome, for the production of a clonal population. This would be the case if a single seedling successfully colonised an area by vegetative spread alone. Decay of the basal

portions of the stolons results in multiplication of the parent genotype by detaching the innovations from each other and from the parent plant.

Perennation by rhizomes also favours the process of vegetative multiplication but, since the rhizomes are short, it favours more intensive cover of the ground already occupied, rather than the colonisation of new ground.

Vegetative propagation, although having the primary effect of producing new individuals with the same genotype as the parent, also affords a possible opportunity for perpetuating cytological changes which might occur in the somatic meristems. Chromosomal structural changes, and gains or losses of chromosomes which become established in a somatic meristem, might be perpetuated and multiplied vegetatively by the action of that meristem. A consequence of this would be that the vegetatively produced offspring of a single plant would differ amongst themselves in respect of chromosome structure or number.

Dispersal of Axonopus by vegetative means plays a greater part in its spread into new habitats than is normally the case in terrestrial angiosperms. Populations established by man may be composed of individuals which have been transported over great distances and are then, at least initially, exposed to conditions which favour turf formation and reduce competition from other species. Such massive bursts of vege-

tative dispersal are of brief duration, but they have the result that a population so established may consist of individuals from a few, or even a single clone. The process tends, therefore, to create a series of uniform populations.

Axonopus compressus - sensu lato - is favoured as a lawn grass and cover crop in Sierra Leone and elsewhere, partly because it can be made to cover the ground rapidly and partly because it is at least as successful under the climatic conditions here as any other lawn or cover grass. In drier territories, Stenotaphrum is preferred because of its more xeromorphic properties, but it does not tolerate the soil water-logging which characterises the wet season in all but the sandy, coastal parts of Sierra Leone. Cynodon is the only other extensively used lawn grass but, although it covers the ground rapidly and is also well adapted to the climate, it has been found to encourage sand-flies (Culicoideae) and is less popular than Axonopus.

The vegetative vigour of Axonopus is most obvious during periods of very active growth. During the dry season (approximately from October of one year to April of the following year) termites consume any litter upon the soil surface so that little remains, in fairly exposed habitats, except the larger pieces of woody debris and the living portions of hemi-cryptophytes. In the account which follows, the sudden and con-

spicuous bursts of vegetative development of Axonopus are related to the meteorological changes which occasion such activity. It is the great vigour of Axonopus under such conditions which enables it to colonise open soil in competition with many other herbaceous plants, and which makes such bursts of activity so conspicuous.

During the dry season of 1957/58, it was noted that periods of active growth were dictated not only by rainfall, humidity and temperature but also by wind, cloud, haze cover and by the extent to which the water content of the soil had been depleted. More than 4 ins (10.2 cms) of rain fell on January 1st, 1958, to be followed by hot dry conditions but no flush of growth. Over the period March 28th - 30th, $1\frac{1}{4}$ ins (3.25 cms) of rain, during a period of cooler, humid conditions, produced a burst of very active growth. Minor periods of activity were noted to have followed periods of high humidity which, during the early part of the dry season, were accompanied by characteristic early morning ground mists. The more noticeable activity towards the end of the dry season was found to occur only when rainfall had been followed by wind conditions which allowed cloud cover or haze to maintain a high atmospheric humidity. Thus, 0.29 ins (0.74 cms) of rain on May 2nd, 1958, followed by three almost windless days, produced a noticeable period of active growth. The three days after the rain were

humid and the night temperatures remained between 64 and 58°F (17.8 and 14.5°C). An earlier (January 1st) fall of rain of 1.57 ins (4 cms), which was caused by the wind backing to the N.E. during a Harmattan period from the E to S.E., was accompanied by hot, dry atmospheric conditions and did not result in a period of active growth.

Of the measurements made during the examination of periods of active growth, low ground temperature shows the closest association. Allowing that there must be a period of lag before growth becomes obvious, grass temperatures (the temperature as recorded at the soil surface on a lawn) of 69 - 66°F (20.6 - 19°C) were noted following rainfall which resulted in periods of active growth, and of 70 - 73°F (21.1 - 22.8°C) following rainfall which did not. These conditions were never realised during the dry season of 1958/59, which was characterised by three distinct and severe periods of Harmattan influence. By April of 1959, the exposed communities (including a lawn which had been regularly irrigated) had died back and their stoloniferous remains had been consumed, leaving detached innovations.

Much more complex relationships control vegetative reproduction and competition during the wet season. Rainfall may exceed 10 ins (25.4 cms) per day and shading due to the growth of taller plants becomes an important factor in deter-

mining the ability of Axonopus, and other herbs, to survive. Waterlogging of the soil causes the breakdown of Axonopus populations, except those of A. flexuosus and A. compressus x flexuosus. These two, and in particular the former, spread most successfully in wet, partly shaded conditions.

Flowering behaviour - the production of spikelets

The number of spikelets produced on a single flowering stem has been mentioned earlier, in the comment on Table 2. These numbers provide a comparison of the taxa, since they can be regarded as indices of reproductive potential. As such they are worthy of further comment.

Each spikelet having a single fertile floret might be regarded as being the initial point in the sexual production of a single new individual. The total number of spikelets produced by one plant can be regarded as the potential size of the next generation. (Clearly this is a fallacious statement in the case of the sterile hybrids, unless a very loose meaning is given to the word 'potential'.) Since Axonopus is perennial and stoloniferous, it continues to produce spikelets for several years and at the same time undergoes vegetative multiplication. It would be most satisfactory to be able to compile figures which took into account the total number of flowering stems produced by a single plant, but in order to obtain com-

parable figures (i.e. figures representing the total numbers of spikelets which a plant of any taxon might be expected to produce in its life span) a protracted schedule of scoring would have to be carried out or a method would have to be devised for the calculation of some factor by which the states of maturity of individual plants could be given parity. It was thought reasonable to compare the total numbers of spikelets which were produced on single flowering stems (i.e. on all the racemes produced upon peduncles arising from a single abbreviated conical axis, as described earlier), since this would avoid protracted scoring, with its possibility of errors, and would provide a numerical comparison in which the numbers were expressions of such taxonomically important features as the lengths of the racemes and the numbers of inflorescences produced.

The figures presented in Table 2 were:-

<u>A. compressus</u>	210
<u>A. compressus x flexuosus</u>	422
<u>A. flexuosus</u>	370
<u>A. brevipedunculatus x compressus</u>	265
<u>A. brevipedunculatus</u>	172
<u>A. arenosus</u>	197
<u>A. affinis</u>	205

Both hybrid taxa show increased flowering vigour over their putative parents and this is most marked in A. compressus

x flexuosus. A. compressus, A. arenosus and A. affinis have comparable reproductive potentials, on the basis of these figures, but A. flexuosus appears to have a greater reproductive potential and A. brevipedunculatus appears to have a significantly lower one. The high values for both A. flexuosus and A. compressus x flexuosus arise because these two taxa have many, fascicled inflorescences bearing long racemes, whereas, by contrast, A. brevipedunculatus has fewer inflorescences with shorter racemes.

Flowering shoots are produced throughout the year by A. compressus, A. brevipedunculatus x compressus, A. arenosus and A. affinis but flowering ceases if the dry season is prolonged or has been severe. A. flexuosus and A. brevipedunculatus flower during the wet season and remain vegetative throughout the dry season.

Anthesis

Anthesis in A. compressus and A. affinis is normal and occurs after the elongation of the peduncle has carried the racemes far out of the ultimate leaf-sheath. In both species the process is protandrous and the release of pollen from the anthers takes place very soon after the exposure of the latter. The stigmas remain exposed for 10 to 12 hours, or occasionally longer, before they are partially withdrawn into the fertile

floret or degenerate.

In A. arenosus and A. flexuosus anthesis occurs less freely, especially in cultivated plants, and in both species occurs when the racemes are only shortly exposed from the ultimate leaf-sheath. In A. arenosus the racemes remain shortly exerted but in A. flexuosus the extension of the peduncles carries the racemes well clear of the leaf-sheath.

Anthesis in the hybrid taxa is uncommon. It is particularly rare in A. compressus x flexuosus and, when it does occur, one or two of the anthers may fail to emerge from the palea and lemma.

A. brevipedunculatus very rarely flowers but has been seen to do so under cooler, humid conditions during the wet season.

These grasses appear to have little sensitivity to day-length as a factor influencing flowering and anthesis. Both these processes continue throughout the year if plants are maintained with an adequate water supply. Some early attempts to induce anthesis were carried out in an insect-proofed breeding house in which day-length alone was controlled. In these attempts, plants were grown in pots and were watered liberally but as no facilities were available for the control of atmospheric humidity and temperature, only day-length conditions could be adjusted, by screening or by fluorescent light extension.

A. compressus flowered freely under short day conditions (diffuse daylight of 12 hours duration), but flowered equally as freely when the plants were bagged with diathene bags and subjected to natural day-length (13 to 13½ hours, under moderate shade) or artificially extended day-length (15 hours) regimes. From this it was concluded that anthesis was controlled by humidity/temperature relationships of the atmosphere rather than by day-length. Further evidence in support of this view was obtained when both A. compressus x flexuosus and A. brevipedunculatus plants contained in diathene bags flowered while unbagged plants in adjacent pots failed to do so. One plant of A. compressus x flexuosus even flowered after an accidental period of 72 hours continuous illumination.

A second attempt to accelerate anthesis was based upon the method, reported by Jordan (1957), which is regularly employed for the hybridisation of Oryza cultivars. Jordan's method relies upon simulation of the atmospheric changes which have been found to obtain during normal anthesis. Vacuum flasks filled with water at 43°C are emptied and quickly inverted over the Oryza inflorescence. As the saturated atmosphere within the flask cools, the spikelets open. This permits the emasculation of spikelets, the collection of pollen and cross-pollination at times when natural anthesis has not yet started. Before attempting to employ this technique on Axonopus, a study

was made of the regularity and timing of anthesis. This was done by inspection of inflorescences, of plants in experimental beds, at five minute intervals between the hours of 7.0 a.m. and 8.30 a.m. daily. These observations were continued for a period of three weeks. Temperature, wind and humidity were recorded and it was found that flowering was associated with falling humidity and rising grass-temperature. In sheltered situations, it was found that flowering was delayed, often to 10.0 a.m. Evening flowering was occasionally observed and was found to be associated with increasing humidity and falling temperature. Attempts to simulate the conditions under which morning flowering occurred, by exposing inflorescences to a warm, humid atmosphere as in Jordan's technique, did not produce any worthwhile results when the attempts were made in the morning (i.e. before 7.0 a.m.) and failed entirely when the attempts were made in the evening.

The timing of anthesis, by inspection, was investigated further by the use of a mechanical device which the writer constructed. This device (see figure 18) consisted of a carriage (a) which was drawn by a thread (b) below and across a slit in a chamber (c), within which an inflorescence was confined. The motive power for the carriage's transit was provided by an additional spindle which the writer built into a stop-clock. A microscope slide smeared with Mayer's albumen was placed upon

FIGURE 18.

Apparatus for timing the release of pollen.

The apparatus consists of a chamber (c), with a slit in its lower corner. A carriage (a) is drawn below the slit by the thread (b), which is connected to a clockwork drive. The microscope slide (d) is transported on the carriage, across the slit, and when pollen is released this falls through the slit and onto the slide. Knowing the rate of transit of the slide across the slit, and the position of the slide at the beginning of transit, the time at which the pollen was released can be calculated from the position of the first pollen grains on the slide.

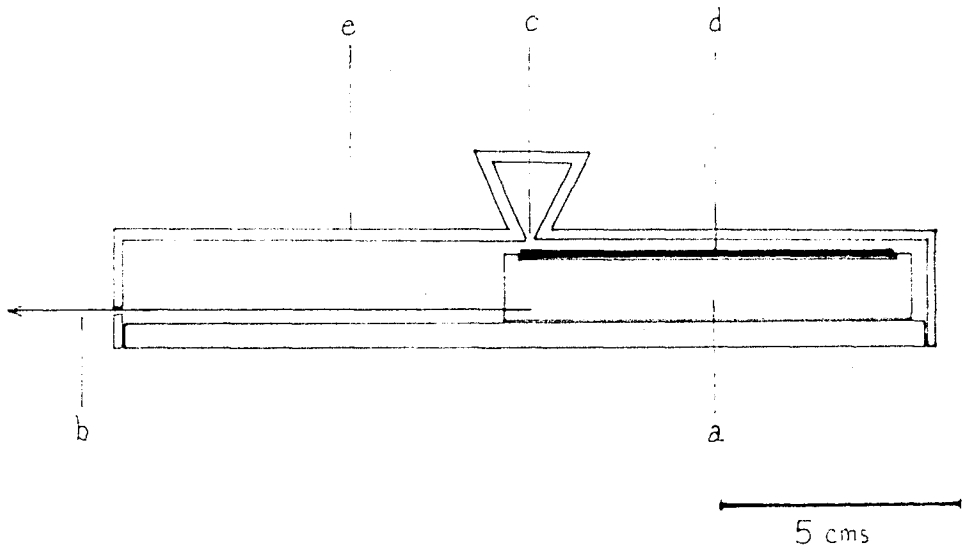

FIGURE 18

the carriage and a reference mark was scribed on it to mark its position at the beginning of the run. If pollen was released during the run, it fell onto the slide and could later be detected by inspection under a microscope; this was made easier by irrigation with aceto-carmin. The rate of transit of the slide was 1.2 cms in 10 minutes and by measuring the distance moved, from the reference mark to the first pollen grains on the slide, the time lapse after commencement of the run, and hence the time of pollen release, could be calculated. By this means the timing of anthesis, which had already been determined by inspection, was confirmed.

Pollination experiments

The Sierra Leone Rice Research Station has obtained some evidence that wind transport of pollen is most effective over very short distances. Cross-pollination decreases rapidly when the distances between panicles exceed some 25 cms. Since crops of rice are grown under conditions in which the wind transport of pollen must be considered as being more efficient than between small grasses in, say, a mixed vegetation of trees, shrubs and herbs, cross-pollination in such small grasses is likely to be effective only over very short distances. Sexual Axonopus populations being perennial and clonal are probably mostly inbreeding. In them, most pollination will be self-

pollination or cross-pollination between closely related individuals or the members of a single clone. Crosses between widely separated individuals will be rare.

In order to examine the wind transport of Axonopus pollen, potted plants of A. compressus were used. These were kept under large diathene bags and observed for several days in order to determine which of their inflorescences were in comparable states of flowering. All but the inflorescences chosen, and those which were much younger, were removed from the plants. It was found possible in this way to remove the undehisced anthers from the newly opened spikelets on several plants in the early morning. If such emasculated plants were kept in isolation, no fruits were set, but when the emasculated inflorescences of several plants were staked at 20 cms intervals in a straight line on either side of an unemasculated inflorescence, the fruits set on the emasculated inflorescences confirmed that transport of pollen over distances greater than 20 cms was not very effective. The results of four such tests are contained in Table 17.

Table 17

position	40cms	20cms	0	20cms	40cms
fruits set	0/6	1/6	Pollen	2/6	0/6
	1/6	2/6	parent	0/6	1/6
	1/6	1/6		1/6	0/6
	1/6	1/6		2/6	0/6
Total set at 40 cms		4	Total set at 20 cms		10

The numbers of fruits set, in each case out of six emasculated spikelets, on inflorescences at each side of the pollen parent are not regarded as being significantly different. Such minor differences may have been caused by daily variation in wind direction and force through the insect-proofed breeding house. The differences between the proportions of fruits set at each of the two distances from the pollen parent (4 out of 48, or $8\frac{1}{3}\%$, at 40 cms and 10 out of 48, or $20\frac{5}{8}\%$, at 20 cms) are regarded as being different.

The following investigations of the breeding mechanisms were performed on potted plants in the insect-proofed breeding house:-

1. Tests for self compatibility.
2. Tests for apomixis.

1. Tests for self compatibility

Single plants were isolated under diathene bags and all old inflorescences were removed. Care was taken to ensure that previously flowered spikelets were also removed from the remaining inflorescences. Such spikelets were detected by the protruding remnants of the stigmas. After thus ensuring that the remaining inflorescences had no spikelets which might have been cross-pollinated, the plants were kept in isolation for a further two days. After that time, the inflorescences were inspected and all but those spikelets which had flowered under conditions of isolation were removed. This ensured against the risk that younger spikelets might subsequently set fruit as a result of cross-pollination and be scored as having resulted from self-pollination.

A. compressus, A. flexuosus, A. arenosus and A. affinis all set fruit when isolated. It was noted, however, that the ovaries in most of the open spikelets of both A. flexuosus and A. arenosus were greatly enlarged. It was also noted that in both these species some fruits were formed on isolated inflorescences in which anthesis failed to occur.

A. compressus x flexuosus failed to set fruit in isolation. The ovaries in open spikelets were long and dorsiventrally collapsed.

A. brevipedunculatus and A. brevipedunculatus x com-

pressus were not investigated. Anthesis did not occur in isolated plants, but fruits were set freely in the unopened spikelets of A. brevipedunculatus.

2. Tests for apomixis.

These tests were made because fruiting in A. flexuosus, A. arenosus and A. brevipedunculatus appeared to be independent of normal anthesis.

Single plants were isolated and their inflorescences were trimmed to remove all spikelets which had obviously flowered. A. compressus and A. affinis were emasculated with fine forceps after normal opening of the spikelets. The stigmas were then inspected under a binocular microscope and any which bore pollen, liberated by rupturing of the anthers during dissection, were excised. The less freely flowering taxa, A. flexuosus, A. arenosus and A. brevipedunculatus, were emasculated by dissection of unopened spikelets. To do this the inflorescences were examined and those parts on which the spikelets had enlarged ovaries were cut away. The anthers were removed, from spikelets which had ovaries of comparable size to those in newly opened spikelets of A. compressus, with flamed needles. The dissections were carried out under a binocular microscope and care was taken to avoid unnecessary damage to the spikelet. It was not possible to avoid some damage to the unhardened glume

and sterile lemma and to the slightly indurate fertile lemma and palea. It is possible that damage was also caused to the rachilla and pedicel during dissection.

No fruits were produced by emasculated spikelets of A. compressus and A. affinis. It was concluded that these two species are obligately sexual and self compatible.

In A. flexuosus few of the emasculated spikelets set fruit. Many of the spikelets fell off, probably as a result of damage caused during dissection, and most of those remaining failed to fruit. This species may be facultatively apomictic but this has not been confirmed cytologically.

Emasculatation of A. arenosus did not inhibit fruiting entirely, nor did removal of the stigmas. A number of spikelets fell off prematurely and some of the remainder failed to fruit. Failure to fruit, as also in A. flexuosus, may have been due to infection by fungi or thrips but could also have been the direct result of emasculatation. A. arenosus is regarded as being facultatively apomictic.

A. brevipedunculatus has been examined in the greatest detail because of its ability to set fruit even in those spikelets which remain confined within the ultimate leaf-sheath. Such spikelets are unable to open and, as the fruits mature, the anthers and stigmas become compressed towards the apex of the fertile floret. Spikelets in which the ovaries are not

enlarged are only found within the sheath. It was found possible to cut away a portion of the sheath and to dissect the anthers from the spikelets and at the same time to cause less damage than was possible with the two previous species. The sheath provided support to the raceme being dissected and the spikelets were easier to open because of the softer condition of the fertile lemma and palea. Few of the emasculated spikelets failed to produce fruit.

Unopened spikelets were examined for cleistogamy. This was done by careful removal of the fertile lemma and palea and mounting the floral organs in cotton-blue in lacto-phenol (Lundquist, 1961). Ungerminated pollen grains and pollen tubes are stained by cotton-blue whereas germinated pollen grains remain almost unstained. No pollen tubes were detected. Also, serial sections of the spikelets were examined for signs of pollen germination in the unopened spikelet and none was found. (The serial sections were prepared for the cytological examination of ovary development, which is considered later.) This suggests that A. brevipedunculatus is an obligate ^{autonomous} ~~apogametic~~ apomict.

The two hybrids, A. compressus x flexuosus and A. brevipedunculatus x compressus, were not examined for apomixis. Sowings of bulk, naturally abscised spikelets confirmed their sterility. Occasional seedlings of the former were ob-

tained but none persisted beyond the four-leaf stage. This suggests that functional ovaries are rarely produced and that, when such ovaries fruit, the offspring derived from them are not fully viable.

The genetic variability within populations will be influenced by the mode of seed production. The two sexually reproducing species, A. compressus and A. affinis, are out-breeders but are also capable of inbreeding. Their populations (even those created artificially by man) will exhibit genetic variability at an early stage. This will arise even when the populations consist, in the first place, of clonal individuals because these will certainly have a high degree of heterozygosity. The existence of the two hybrid taxa confirms that outbreeding occurs between their putative parents. The sterility of these hybrids provides a barrier to gene flow between the parent species, but it is conceivable that some back-crossing of the hybrids to A. compressus may be possible. The extent of such back-crossing would depend upon production of functional pollen and ovaries, the frequency with which the spikelets opened and the release of pollen from the anthers of the hybrids. Although some seed is evidently produced by A. compressus x flexuosus, all the ovaries which have been examined, both of this and of A. brevipedunculatus x compressus, were collapsed.

Anthesis does not occur as freely as in the sexual species and when it does occur the anthers do not always emerge fully. The pollen which is produced includes some apparently good grains, as is shown in the table.

Table 18

Comparison of pollen produced

	staining with aceto-carmin	grain diameter (microns)
<u>A. compressus</u>	96%	all 28
<u>A. compressus</u> <u>x flexuosus</u>	17%	10% 31, 30% 29, 60% 25
<u>A. flexuosus</u>	96%	all 29
<u>A. brevipedunculatus</u> <u>x compressus</u>	30%	all c.29
<u>A. brevipedunculatus</u>	87%	all 28
<u>A. arenosus</u>	95%	all 29
<u>A. affinis</u>	96%	all 28

Seventy percent of the pollen grains of A. brevipedunculatus x compressus were collapsed so that it was difficult to distinguish variation in grain diameters.

From Table 18 it can be seen that both hybrids produce some apparently good pollen and might, therefore, occasionally act as pollen parents in back-crosses to A. compressus.

The evidence obtained relating to seed production in A. flexuosus and A. arenosus is inconclusive but suggests that both species are facultative apomicts. Agamospermy, or repro-

duction by seed which is produced by other than the normal process of fertilisation, reduces genotype variability but in most cases maintains heterozygosity. Facultative apomicts derive selective advantage from breeding mechanisms which isolate them from their less specialised relatives. Their offspring inherit genotypes which ensure their success in the parental habitat. The incidence of sexual reproduction determines the rate at which new genetic combinations are introduced into the population. It is clear that sufficient phenotypic plasticity exists in such a breeding system in A. flexuosus, since this species occurs in specialised habitats in a number of climatically different areas of Africa.

In the obligate apomict, A. brevipedunculatus, genotypic variability must be confined to any structural heterozygosity or mutation which becomes established in a somatic meristem. Such rare genotypic variants would be multiplied by vegetative reproduction and would also allow recombination during the apomictic production of seed. It will be seen in the next section that the apomictic mechanism in A. brevipedunculatus ensures that each of the offspring is completely homozygous but if the parent has any heterozygosity (such as may arise somatically) the offspring could be different homozygous recombinants. Populations of A. brevipedunculatus show minor phenotypic differences as a consequence of such recombinations.

Embryo sac formation



Materials and methods

Spikelets were removed from young racemes and the second glume, sterile lemma and distal third of the fertile floret were cut away. This was found to be necessary for the removal of air and to ensure the adequate penetration of the wax during impregnation. The material was killed in formalin-acetic-alcohol and fixed in 70% alcohol. A tertiary butyl-alcohol series was used for impregnation and two changes of 60°C melting point wax were made before the material was blocked. Great care had to be exercised in the last stages of impregnation to avoid excessive heat, since this causes the lemma and palea to become hard and brittle.

Sections were cut at thicknesses of 8 to 10 microns, in a lateral vertical plane, and were stained either with haematoxylin and safranin or with crystal violet and iodine. Both staining methods worked satisfactorily but the crystal violet method had the advantage that the intensity of the stain could be more easily controlled, or increased, or reduced, before the slides were made permanent.

The sexual process

A. compressus

A diagrammatic reconstruction of the sequence of events in the formation of the embryo sac, as deduced from serial sec-

tions, is contained in figure 19, 1 to 7.

The archesporial cell (ar, in figure 19, 1) differentiates as a hypodermal cell of the nucellus at a time when the integumental layers (ii and oi) are developing and before the growth of the funicle has orientated the micropyle (m) towards the base of the ovary.

Diakinesis in the megaspore mother cell occurs at about the same time as that in the pollen mother cells in the anthers. The first metaphase spindle (sp, in figure 19, 2) is slightly inclined to the long axis of the ovule. The second division of the micropylar daughter nucleus is also inclined and the tetrad which results from the meiotic division has a T-shaped appearance. Because of the early degeneration of the nuclei and cytoplasm, the identity of the three megaspores (ms1, ms2 and ms3 in figure 19, 3) nearest the micropyle is lost. The chalazal megaspore or embryo sac initial (esi) enlarges considerably before the mitotic divisions commence.

The first mitotic division is orientated along the long axis of the ovule and gives rise to one nucleus at the chalazal end (c, in figure 19, 4) and one at the micropylar end (e). The cytoplasm becomes highly vacuolated when this first division is complete. Each nucleus divides twice more and the products of the divisions remain at opposite poles of the embryo sac (figure 19, 5 and 6). After the 8-nucleate stage is achieved

FIGURE 19.

Formation of the embryo sac in A.compressus(Sw.)Beauv..

1. Differentiation of the archesporial cell from the nucellus. The archesporial cell is at diakinesis and the inner integument is growing up around the nucellus.

2. First metaphase in the archesporial cell. Both integuments have developed and the nucellus has enlarged.

3. The ovule after completion of megasporogenesis. Three megaspores are degenerating and the fourth is enlarging as the embryo sac initial. The cells of the inner integument have enlarged around the micropyle.

4. Binucleate stage. The daughter nuclei are at opposite poles of the embryo sac. The cytoplasm has vacuolated.

5. Four-nucleate stage.

6. The young 8-nucleate embryo sac. Three antipodal nuclei remain at the chalazal (upper) end of the sac. The fourth is migrating towards its micropylar partner; these become polar nuclei. The egg nucleus and the two synergids have adopted the positions which they will occupy in the mature embryo sac.

7. The mature embryo sac. The antipodal cells have divided to give a tissue of nine cells. The polar nuclei lie close to the enlarged, centrally placed egg cell. The synergids have started to degenerate.

ant = antipodal cells

ar = archesporial cell

c = chalazal nucleus

e = micropylar nucleus

egg = embryo sac initial (inner megaspore)

ii = inner integument

m = micropyle

ms 1,2 and 3 = three degenerating megaspores

oi = outer integument

pi = chalazal polar nucleus

pii = micropylar polar nucleus

pn = polar nuclei

sp = first metaphase spindle in the archesporial cell

sy = synergids.

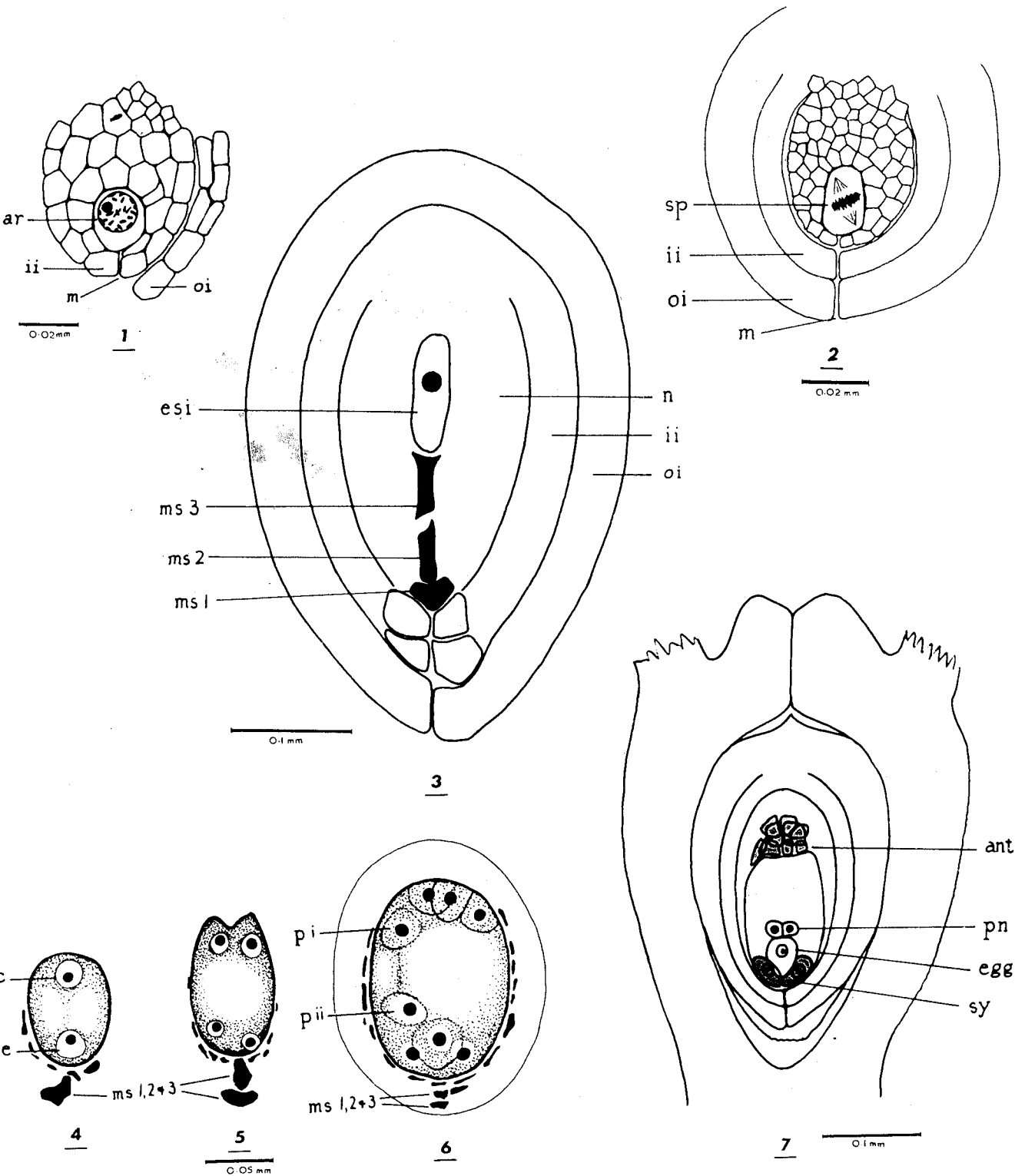

FIGURE 19

one nucleus from the chalazal group (pi) migrates towards the micropylar group. It associates with one of the micropylar group of nuclei (pii) and these two together form the ^{polar} ~~endosperm~~ nuclei (en, in figure 19, 7).

The three remaining chalazal nuclei divide once or twice more and form a tissue of 9 to 12 antipodal cells (ant).

The micropylar group of nuclei also become bounded by cell walls. Two become the laterally placed synergids (sy) and the third becomes the more centrally placed egg cell (egg). The mature embryo sac is thus of the Polygonum type (Maheshwari, 1950).

The apomictic process

A. brevipedunculatus

The initial stages in the development of the ovary are the same as those in A. compressus (figure 19, 1 to 4). A much enlarged archesporial cell undergoes meiotic division (figure 20, 1) and gives rise to a T-shaped tetrad of megaspores. As degeneration of the three micropylar megaspores proceeds, one or more of the nucellar cells adjacent to the inner megaspore enlarge (figure 20, 2, n). These are regarded as being potential aposporous embryo sac initials, but only rarely does their subsequent development produce an embryo sac. In the many hundreds of ovaries examined the embryo sac ~~was~~ derived from the reduced

inner megaspore.

Division of the nucleus of the reduced megaspore gives a two-nucleate condition (figure 20, 3) which is followed by vacuolation of the cytoplasm. This distinguishes the haploid process from the diploid process, since the 2- and 4-nucleate diploid conditions do not have vacuolated cytoplasm. A second mitotic division produces a four-nucleate condition with a pair of nuclei (c, in figure 20, 4) at the chalazal end and a pair (e) at the micropylar end. At this stage the embryo sac begins to increase in size and as it does so it compresses the surrounding nucellar cells (nc). The third mitotic division of the chalazal group of nuclei and of one of the micropylar nuclei is complete. The remaining micropylar nucleus undergoes chromosome division but the products are contained within a single nuclear membrane. (x). The diploid nucleus so produced exhibits a characteristic but transient bi-nucleolate appearance. Rarely the condition illustrated in figure 20, 6 was observed. The diploid "egg" was accompanied by one synergid (sy) and an enucleate and degenerating "cell" (x). In the great majority of embryo sacs examined, only a single degenerating synergid was observed. All the older embryo sacs contain only seven nuclei.

One of the chalazal group of nuclei (pi) migrates towards the micropyle and associates with one of the reduced micropylar nuclei (pii). These two become the ^{polar} endosperm nuclei

FIGURE 20.

Formation of the embryo sac in A. brevipedunculatus.
(Reconstructed from serial sections)

1. The archesporial cell has enlarged much more than the remaining nucellar cells. Its first division is a meiotic reduction division, and at first metaphase the 20 bivalents are easily distinguishable. This is very distinct when compared with a mitotic metaphase plate, in a nucellar cell.

2. The inner megaspore has enlarged and two nucellar cells have also enlarged. These are potential aposporous embryo sacs. The three micropylar megaspores have degenerated to a T-shaped mass.

3 & 4. Mitotic divisions of the megaspore nucleus give first a 2-nucleate condition and then a 4-nucleate condition.

5. The third mitotic division is complete at the chalazal end of the embryo sac, and in one nucleus at the micropylar end. The remaining micropylar nucleus has failed to divide, after the chromosomes have divided, and has become diploid and 'bi-nucleolate'.

6 & 7. The polar nuclei have associated towards the micropylar end, and the pro-embryo initial has assumed its characteristic lateral position. The single synergid is degenerating.

8. Double embryo sacs. These are produced when an aposporous embryo sac (left) forms, in addition to the automictic embryo sac.

The aposporous e.s is smaller and has the egg cell placed towards its centre. Its antipodal cells form a detached group.

- ant = antipodal cells.
- ar = archesporial cell.
- ap = aposporous embryo sac.
- ant = automictic embryo sac.
- a. ant = antipodal cells of aposporous embryo sac.
- a. esi = embryo sac initial, aposporous.
- c = chalazal nucleus.
- e = micropylar nucleus.
- egg = egg cell.
- en = paired polar nuclei.
- ji = inner integument.
- m = micropyle
- ms 1,2 & 3 = the three degenerating megaspores.
- m = mitotic metaphase in nucellar cell.
- nc = compressed nucellar cells.
- oi = outer integument.
- pei = pro-embryo initial
- pi = chalazal polar nucleus.
- pri = micropylar polar nucleus.
- sy = synergid
- x = enucleate cytoplasm.

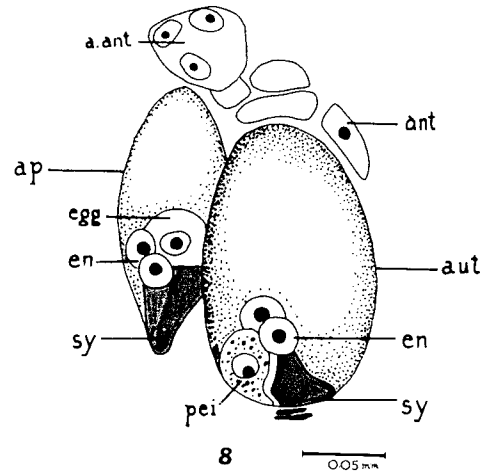
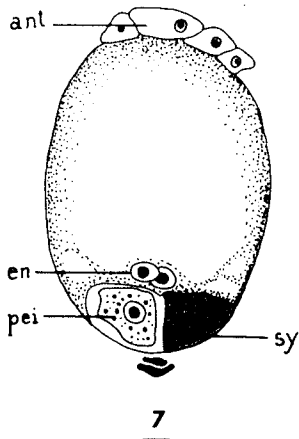
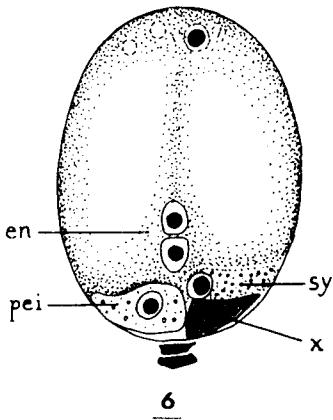
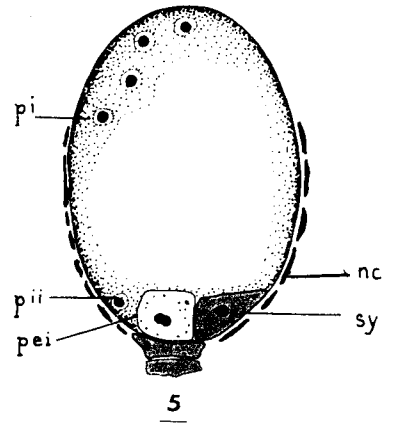
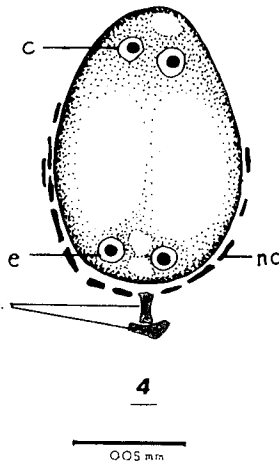
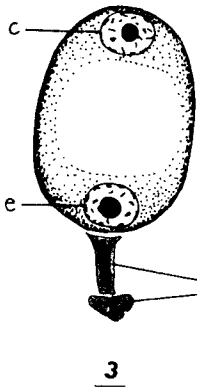
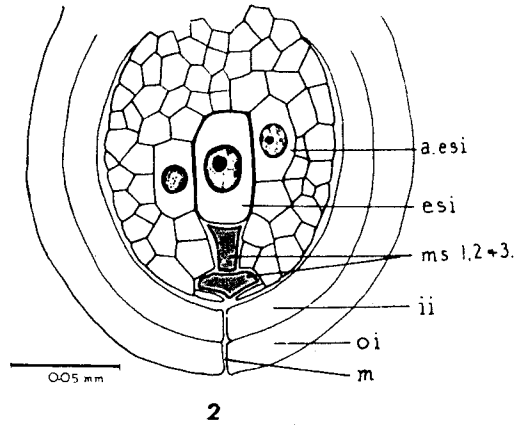
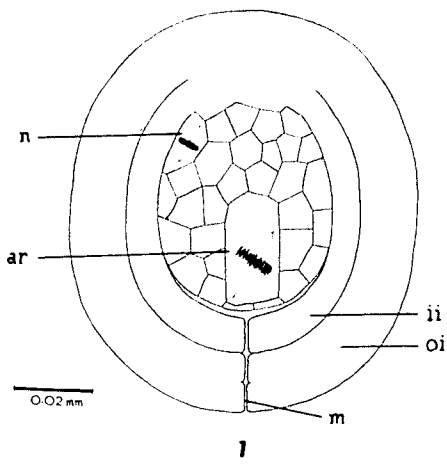

FIGURE 20

(en, in figure 20, 6, 7 and 8). The remaining chalazal nuclei divide to produce up to 9 antipodal cells (ant, in figure 20, 7 and 8), and the remaining micropylar nucleus forms a synergid (sy) which then degenerates.

The diploid nucleus becomes surrounded by highly refractive, granular cytoplasm and is cut off by a cell wall to become the pro-embryo initial (pei in figure 20, 6, 7 and 8). It always occupies a position lateral to the long axis of the embryo sac, at the micropylar end.

This mode of production of a diploid "egg" cell is called automixis and was first described by Thomas (1940) in Rubus loganobaccus Bailey. Related processes, in which chromosome doubling occurs during the meiotic interphase, are known in Allium (Levan, 1935) and Hieracium (Bergman, 1941).

Ovules in which aposporous embryo sacs were observed were rare. Such ovules always contained two embryo sacs; one produced from a reduced megaspore (ant, in figure 20, 8) and the other from a nucellar megaspore (ap).

The aposporous embryo sac is always disposed to one side of the ovule. It is produced by three mitotic divisions and is therefore eight-nucleate. The antipodal nuclei become separated from the embryo sac as a three-nucleate cell (a.ant) which degenerates early. Two polar nuclei (a.pn) associate towards the micropylar end but seldom lie in a central position

within the embryo sac. The egg cell is large by comparison with those of reduced embryo sacs and its contents do not become granular. Two synergid cells at the micropylar end degenerate early.

The structure of the aposporous embryo sac resembles that, described by Snyder (1957), in Paspalum secans Hitchc. and Chase.

Consequences of automixis

Unlike other forms of agamospermy, automixis does not allow the transmission of heterozygosity, which may be present in the parent, to the offspring. In diplospory the embryo sac mother cell develops from the archesporial cell, or from one cell produced from the archesporial cell, by mitotic divisions alone. The diploid nuclei of the embryo sac therefore inherit the maternal diploid complement of chromosomes and any heterozygosity which they carry. In apospory the function of the archesporial cell is aborted and the embryo sac is produced by mitotic division of one of the somatic cells of the ovule. In adventitious embryony the function of the embryo sac is aborted and the embryos develop from somatic cells of the ovule. Since meiosis is not involved in these processes there can be no segregation of characters which are present in a heterozygous condition in the parent.

In automixis the formation of the embryo sac mother cell, by meiotic division of the archesporial cell, presents the possibility that in separate ovaries any heterozygosity in the parent genotype may be resolved into different combinations. The embryo sac nuclei all have the same haploid complement, and the failure of the mitotic products of one micropylar nucleus to separate must always result in the pro-embryo initial being completely homozygous:-

	unlinked genes	linked genes
Parent genotype	AaBb	$\frac{C \cdot c}{D \ d}$
Haploid E.M.C.	AB, Ab, aB or ab	$\frac{C}{D}, \frac{c}{d}$ (or $\frac{C}{d}$ and $\frac{c}{D}$, x-overs)
Diploid P.E.I.	AABB, AAbb, aaBB or aabb	$\frac{C \cdot C}{D \ D}, \frac{c \cdot c}{d \ d}, \frac{C \cdot C}{d \ d}$ or $\frac{c \cdot c}{D \ D}$

Any population of automictic plants which evolves from a sexual ancestor, by adoption of the automictic breeding mechanism, must initially contain individuals with numerous different genotypes. It may be supposed that many of the homozygous recessive conditions would be at a selective ^{dis}advantage and that the recessive alleles would rapidly be eliminated from the population. Genetic variability in such circumstances would be restricted to somatic mutation and changes in chromosome structure. If these somatic events should become established in a meristem

they might reintroduce heterozygosity in the vegetative products of the meristem (stolons, rhizomes and flowering stems). Genetic variability would not, therefore, be very great within the population.

The effect of natural selection upon an automictic population will be to favour certain genotypes and to eliminate others. Since variation can not be increased by sexual recombination, the genotype array of the automictic population will be much smaller than that of a sexual population, in which a balanced reserve of heterozygosity is maintained.

A. compressus x flexuosus

In all material of A. compressus x flexuosus examined, embryo sac formation failed. The archesporial cell enlarges but either degenerates before the meiotic division commences or, more characteristically, the tetrad is produced and all the megaspores degenerate immediately. The ovary becomes elongated before degeneration of the megaspores begins, but collapses as degeneration proceeds.

A. flexuosus

A detailed investigation of embryo sac formation has not been completed for this species. Meiosis in the megaspore mother cell is delayed, with respect to meiosis in the pollen

mother cells. The consequence of this is that the nucellus is much larger than in, say, A. compressus. Mature embryo sacs are situated close to the micropylar end of the ovule and have structures which closely resemble those described below for A. brevipedunculatus.

A. brevipedunculatus x compressus

Degeneration of the whole tetrad of megaspores, either before or after the enlargement of the inner potential embryo sac initial, caused the failure of embryo sac formation in all the material examined.

A. arenosus

No detailed study of embryo sac formation has been made in this species. The meiotic division of the archesporial cell is greatly delayed, with respect to the division of the pollen mother cells, but on completion gives a T-shaped tetrad. Only the inner megaspore persists and gives rise to a seven-nucleate embryo sac. It is probable that the intermediate stages, in the formation of this seven-nucleate stage, are the same as those described for A. brevipedunculatus.

A. affinis

Embryo sac formation has not been investigated in this species.

FIGURE 21.

A. brevipedunculatus. 1. Development of the pro-embryo before the fusion and first division of the polar nuclei. The pro-embryo is shown at about the 8-celled condition.

2. Development of the endosperm before the first division of the pro-embryo initial.

(Reconstructed from serial sections).

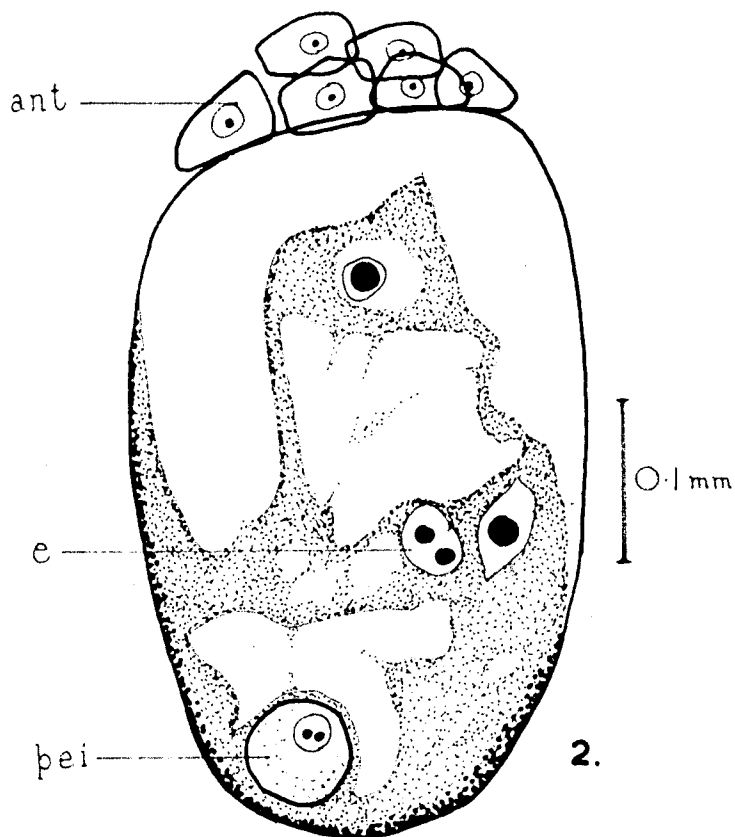
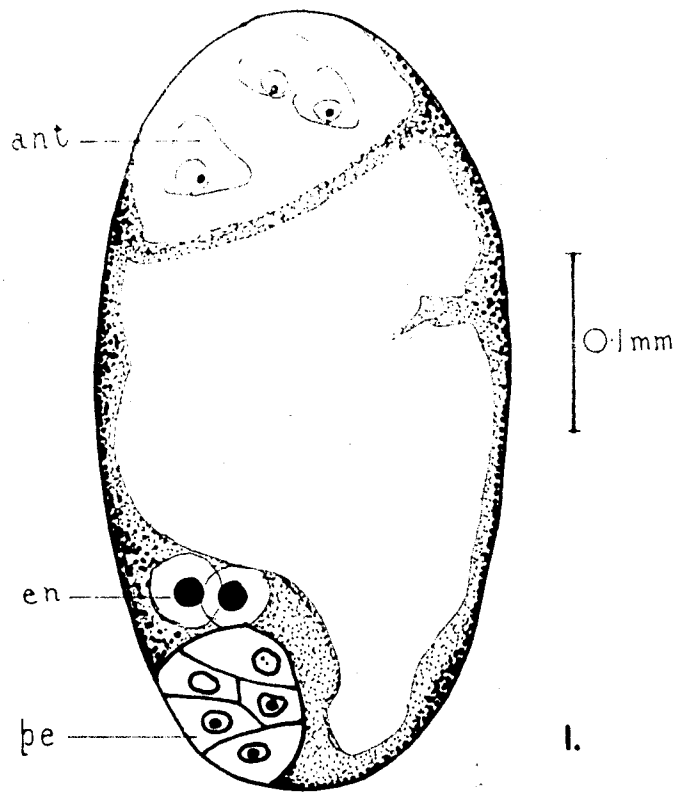

FIGURE 21

Embryo and endosperm formation in *A. brevipedunculatus*

There is considerable variation in the incidence of the first embryo and endosperm divisions. This species is an autonomous apomict, therefore endosperm development is not initiated by or dependent upon fertilisation of the polar nucleus. Multinucleate endosperm was found in ovaries whose pro-embryo initials had not divided (figure 21, 2). In other ovaries, pro-embryos of ten to twelve cells were found, accompanied by unfused polar nuclei, or by the uni-nucleate polar body (figure 21, 1). As judged from the fact that ovaries seldom fail to produce good fruit, the lack of synchronisation between endosperm and embryo development has little effect in the early stages.

Counts of chromosomes during mitotic endosperm division showed that the endosperm has the diploid somatic number of 40 (figure 22, A). Similar counts made on endosperm of *A. arenosus* showed this species also to have the somatic number of 60 (figure 22, B). This confirms that both species are apomictic and that the seed develops autonomously.

FIGURE 22.

Endosperm mitosis in A.brevipedunculatus (a), showing 40 chromosomes, and A.arenosus (b), showing 60 chromosomes.

These counts confirm that in both these species the endosperm is produced without fertilisation.

(Phase contrast photomicrographs)

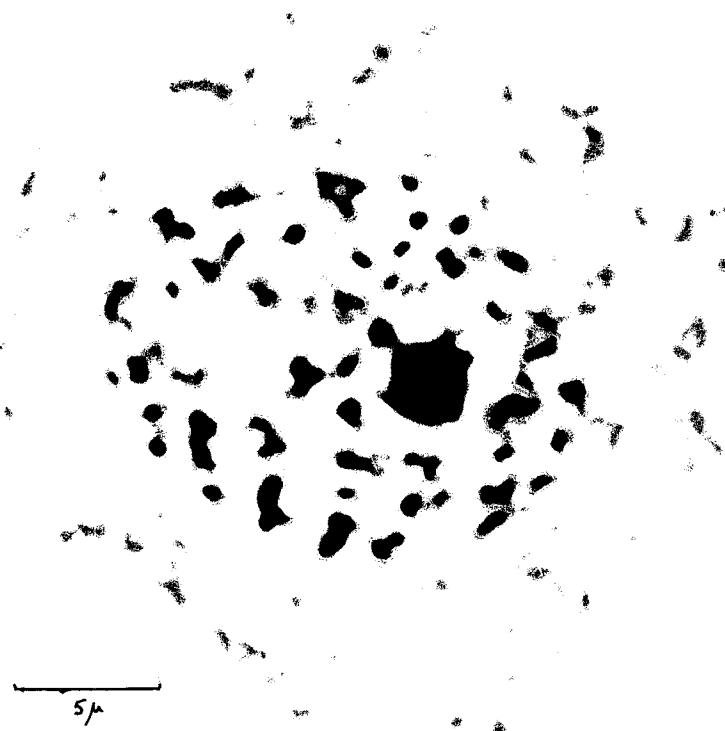
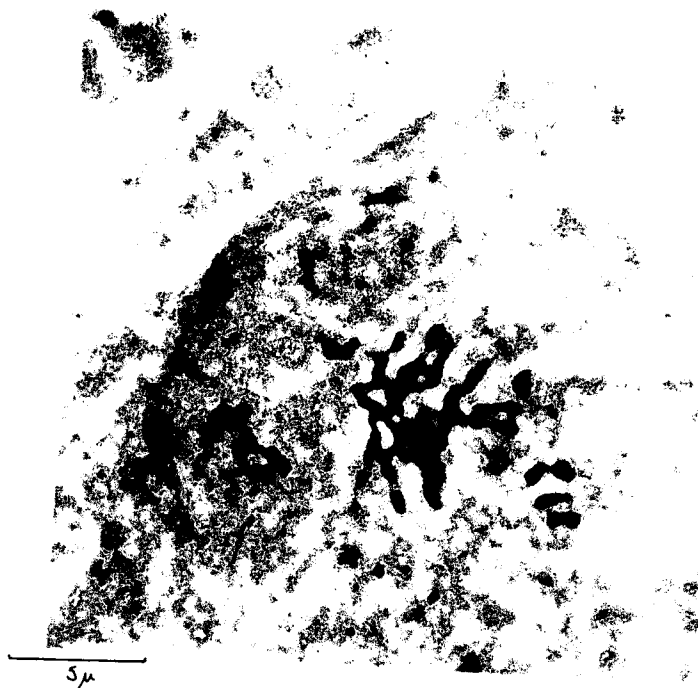

FIGURE 22

Experimental crosses

Materials and methods

The plants employed in the hybridisation experiments were selected from the experimental beds and established as single plant pot-cultures in the breeding house. Their cytology was examined by root and anther squashes in order to ensure that the hybrids' chromosome behaviour could be related to the parental chromosome complements.

The technique employed for cross pollination was similar to that described by Jenkins (1924). The inflorescence of the seed parent was reduced to two racemes, to facilitate handling, and was then isolated under a large diathene bag until anthesis commenced. The spikelets which opened on the first day were removed and, on the second and third days, the spikelets which opened were emasculated and cross pollinated. All spikelets which had not flowered by the third day were removed from the racemes and the inflorescences were kept isolated for a further 48 hours before the diathene bags were removed.

Two methods of applying pollen were used. When the pollen parent had open spikelets its inflorescence was brushed against the emasculated inflorescence of the seed parent and the latter was then inspected for the presence of pollen upon the stigmas. When the anthers of the pollen parent were unruptured, or when the pollen parent spikelets were not open, anthers were removed with fine forceps (from the open spikelets

or from spikelets which, it was judged, contained mature anthers) and were ruptured before being inserted into the fertile floret of the seed parent spikelet.

Each of the crosses attempted was repeated on four separate inflorescences and in a total of twenty spikelets. The cross A. compressus x A. compressus x flexuosus was further repeated, in a total of 60 spikelets.

Because A. compressus could be relied upon to have open spikelets every day it was used as seed parent in all the crosses. No crosses involving A. affinis and A. brevipedunculatus x compressus were attempted. A. affinis was not used because, although it has apparently evolved from A. compressus, any cross between these two species would only be of use as an investigation of the possible mode of evolution of A. affinis. Since this work is primarily concerned with West African taxa it was decided not to employ A. affinis. A. brevipedunculatus x compressus was not used because of the difficulty of determining which spikelets might contain mature anthers. Its spikelets never opened and its ovaries were always collapsed; whereas in the other taxa either the spikelets opened (so that adjacent ones could also provide anthers) or did not open but the size of the ovaries gave an indication of the maturity of the spikelets and their anthers.

The following crosses were attempted:-

1. A. compressus (101, 2n=40) x A. compressus x flexuosus
(201, 2n=c.50)
2. A. compressus x A. flexuosus (206, 2n=60)
3. A. compressus x A. arenosus (304, 2n=60)
4. A. compressus x A. brevipedunculatus (302, 2n=40)

A. compressus x A. compressus x flexuosus

Seven seeds were obtained from this cross and four seedlings were raised to the two or three leaf stage before they died. The seedlings were chlorotic and their deficient pigmentation might have resulted from the lack of transmission of some control system from the pollen parent. The low interfertility of the cross can be explained as being caused by genetic unbalance of the microspore nuclei. Few such microspore nuclei would give rise to male gametes which were functional or which would produce a functional zygotic condition. It should, however, be possible to obtain an occasional viable hybrid from this cross.

A. compressus x A. flexuosus

Fourteen fruits were obtained from this cross and nine hybrids were raised. The mortalities were probably due to the plants concerned being unable to resist the attacks of fungi and thrips which were found on them. (For long periods during

FIGURE 23.

Meiosis in the hybrid A.compressus x A.flexuosus.

Two P.M.C.s at diakinesis, showing a few chromosomes associated as bivalents and the remainder as multivalents. The attenuated threads which interconnect the chromosomes are not distinct in the photograph.

(Phase contrast photomicrograph)



the year, the atmospheric humidity in Freetown is between 85% and 100%. Under these circumstances, it is virtually impossible to maintain sterile conditions without greatly altering the ambient temperature.)

A. compressus x A. arenosus

Nine fruits were obtained from the cross and seven hybrids were raised.

A. compressus x A. brevipedunculatus

Eighteen fruits were obtained, of which seven failed to germinate. Eight hybrids were raised.

Morphology of the hybrids

A biometric comparison of the hybrids was made and the results are contained in Tables 19 and 20. Table 19 compares the means of samples of 20 measurements (except for spikelet and fertile floret lengths and percentage of good pollen, for which the samples were of 100 measurements) and also compares the hairiness of the nodes, leaves and spikelets. The lower figures, as in Table 2, are the standard errors of the means.

The hybrids of the cross A. compressus x A. flexuosus were variable in the lengths of the culm-leaf, culm-sheath and stolon internodes. The culm leaves were conspicuously shorter than those of either parent and the stolon internodes, although of intermediate length, were slender and very variable in length. Maternal characters which appeared in the hybrids included hairy stolon nodes and reddish stolon internodes but the length of the tiller leaves more closely resembled that of the pollen parent. The second glume had five veins, like the seed parent.

The hybrids of the cross A. compressus x A. arenosus were vigorous. One plant was chlorotic and much less vigorous than the others. They had intermediate leaf widths and spikelet lengths and the exertion of the inflorescences was variable, but more similar to the exertion in A. compressus. They had hairy stolon nodes, like A. compressus, but in all other characters were larger than either parent. All the parameters showed

Table 19

Comparison of dimensions of hybrids

Hybrid	A	B	C
Culm length	38.0 0.641	32.1 0.983	18.9 0.369
Culm-sheath	14.0 0.313	16.2 0.372	11.7 0.407
Culm-leaf	4.7 0.115	7.0 0.284	5.6 0.326
Tiller leaf length	23.6 0.457	18.9 0.628	11.1 0.313
Tiller leaf width	12.5 0.096	13.2 0.411	14.0 0.204
Stolon internode	7.1 0.442	8.0 0.303	4.8 0.137
Stolon width	2.4	2.2	1.8
Longest raceme	13.5	12.0	8.2
Spikelet length	2.5 0.021	2.6 0.029	2.4 0.022
Fertile floret	1.7	1.9	1.7
Nodal hairs	++	+	++
Leaf hairs	-	-	+
Spikelet hairs	-	+	+
% good pollen	20	10	32

The means are for samples of 20 measurements, except for spikelet and fertile floret lengths and percentage good pollen. The lower figures are standard errors of the means.

A = A. compressus x A. flexuosus

B = A. compressus x A. arenosus

C = A. compressus x A. brevipedunculatus

high variability; the least variable being spikelet length.

The hybrids obtained from the cross A. compressus x A. brevipedunculatus were morphologically variable, particularly in the hairiness and colour characters of the stolons and leaves and the lengths of the culm-sheath and its leaf. All the plants were robust and had broader but shorter leaves than either of their parents.

The hybrids are compared with their parents in Table 20, which is compiled from the data contained in Tables 2 and 19. As in Table 4, the mean values of the parameters are compared in pairs by Student's t-test, for 38 degrees of freedom (98 degrees of freedom for spikelet length). Values of t greater than 3.29 are interpreted as indicating that the means are significantly different at the 0.1% level of probability.

The Table shows that all the hybrids are significantly different from their parents in respect of their culm lengths and spikelet lengths. The A. compressus x A. flexuosus hybrids are not significantly different from their paternal parent in respect of tiller-leaf length and the A. compressus x A. arenosus hybrids are not significantly different from their maternal parent in respect of culm-leaf length. The A. compressus x A. brevipedunculatus hybrids are not significantly different from their maternal parent in respect of culm-leaf length and stolon internode length and are not significantly different from their

Table 20

Comparison of hybrids and their parents

(The hybrids are indicated by the same symbols as in Table 19.)

	Parents	A. comp.	A. flex.	A. aren.	A. brevi.
Culm length	Hybrids				
	A	16.1	14.6		
	B	5.6		18.2	
	C	14.7			8.1
Culm-sheath	A	9.7	35.1		
	B	12.4		26.8	
	C	4.6			0.6
Culm-leaf	A	5.7	16.6		
	B	0.6		5.9	
	C	2.3			2.0
Tiller-leaf length	A	15.3	0.9		
	B	4.6		10.3	
	C	13.7			2.6
Tiller-leaf width	A	7.5	39.6		
	B	6.3		4.4	
	C	10.5			0.7
Stolon internode	A	3.7	34.9		
	B	7.7		10.0	
	C	2.9			14.9
Spikelets	A	10.6	26.3		
	B	11.5		11.5	
	C	6.9			12.6

The table contains values of t (difference between means \div root of the sum of the squares of the standard errors), of which those greater than 3.29 indicate that the differences between the means are significantly different.

paternal parent in respect of the lengths of the culm-leaf and culm-sheath, or the length and width of the tiller-leaves.

Cytology of the hybrids

A. compressus x A. flexuosus. Root tip squashes, after pre-treatment with α -mono-bromo-naphthalene, gave a somatic chromosome number of 50. Meiosis in the pollen mother cells was irregular and exhibited considerable 'stickiness' of the chromosomes. At diakinesis the chromosomes were interconnected by attenuated threads and so formed multivalents (figure 23). This suggests that the linear structure of the parental chromosomes is different and, since few univalents were formed, that the more numerous chromosomes of the pollen parent have segmental homology with those of A. compressus.

Only 20% of the pollen grains examined stained with aceto-carmin and the ovaries collapsed at a very early stage.

A. compressus x A. arenosus. Pre-treated root tips gave a somatic chromosome number of 50. Meiosis in the pollen mother cells was irregular due to the formation of multivalents. No univalents were observed.

Less than 10% of the pollen grains stained and the ovaries collapsed at an early stage.

A. compressus x A. brevipedunculatus. Pre-treated

root tips gave a somatic chromosome number of 40. Meiosis in the pollen mother cells was irregular due to the formation of quadrivalents and trivalents, but no univalents were observed. This suggests that the parental sets of chromosomes differ in linear structure and in respect of interchanged segments; in the parental 'homozygote' the interchange chromosomes would pair normally but in the 'heterozygous' hybrid interchange and normal chromosomes would form quadrivalents.

32% of the pollen grains stained and the ovaries collapsed at an early stage.

The cytology of the artificial hybrids differs from that of the natural hybrids. The latter produce a high proportion of bivalents whereas the former produce multivalents. This could be explained by the fact that the natural hybrids have been exposed to natural selection which has favoured those plants with the highest degree of chromosome homology. This does not hold for two of the A. compressus x flexuosus populations (202 and 204) which have been examined. If such selection continued, a state of full homology would finally be achieved and this might be accompanied by an ability to produce seed.

Morphologically, the artificial hybrids of the cross A. compressus x A. flexuosus were smaller in most respects than the natural A. compressus x flexuosus. Their stolons and racemes

were of about the same dimensions and their leaves were rigid and without epidermal hairs. A closer resemblance to natural A. compressus x flexuosus was found in the hybrids of the cross A. compressus x A. arenosus. The latter were less tall and had shorter tiller-leaves and, because they were less stoloniferous, they formed rosettes rather than tufts as in the natural hybrid. In all the other characters there was little difference between the two.

Artificial A. compressus x A. brevipedunculatus had slightly longer leaves, longer and more slender stolon internodes and shorter spikelets than natural A. brevipedunculatus x compressus but there was a strong similarity between the two in all the other characters.

Discussion

Some circumstantial evidence relating to the presence of Axonopus in West Africa will be considered, before a discussion of the taxonomic proposals and evolutionary processes.

The taxonomy will be discussed in relation to the distribution of the West African taxa, and their variability. The evolution of the taxa recognised in this account will be discussed in terms of ecological variability, cytological changes and apomixis.

Two opposite views are held concerning the region in which the Paniceae originated. Hartley (1958) favoured the view that the endemics of Madagascar (Lecomtelleae and Boivinelleae) and the related South African Miscanthidium (Andropogoneae but close to the Paniceae (Pilger, 1954, Tateoka, 1957)) indicate a South African centre of origin for the whole of the Panicoideae. Potzta (1956) favoured the view that the 81 genera which are endemic in the Western hemisphere, of which 41 are confined to that area, indicate a tropical American centre of origin. It is largely a matter for philosophical conjecture as to whether;

1. the Paniceae proliferated during their migration from a South African origin to the South American area, or
2. the main proliferation was in a South American centre of origin, from which little migration has occurred, or
3. the centre of origin was split by Continental Drift, and

the new climatic regime of South America favoured greater proliferation than was possible in South Africa.

The present preponderance of Panicaceae in N.E. tropical America is due to the large genera Paspalum, Panicum and Axonopus. There can be no doubt that Axonopus originated in that area and that its advanced form indicates a fairly recent origin. The percentages of Panicaceae in the grass floras of the world are mapped in figure 24. It will be seen that the highest percentages are in N.E. tropical America, the area in which there is the greatest number of Axonopus species (figure 1). Outside that area only the A. compressus complex extends as a disjunct series of populations through most of the tropics and some subtropical areas.

A. compressus - sensu lato - has been intentionally introduced into Australia and the Malayan Archipelago and attempts at introduction have been made elsewhere. Although little definite information has been obtained, the writer considers that intentional or accidental introduction can account for the presence of A. compressus in all its non-American areas. This view is held for two reasons. First, it is the only species (complex) of which herbarium material from the non-American areas has been found. Many herbaria contain specimens of Allo-teropsis species which are shelved as species of Axonopus, but there is no doubt that these are not species of Axonopus.

FIGURE 24.

Map showing the percentage of Paniceae in the grass floras of the world (after Hartley, 1958). The Paniceae are most numerous in tropical American grass floras and in West and Central Africa. The high percentage in N.E. tropical America is due to the three large genera Axonopus, Paspalum & Panicum

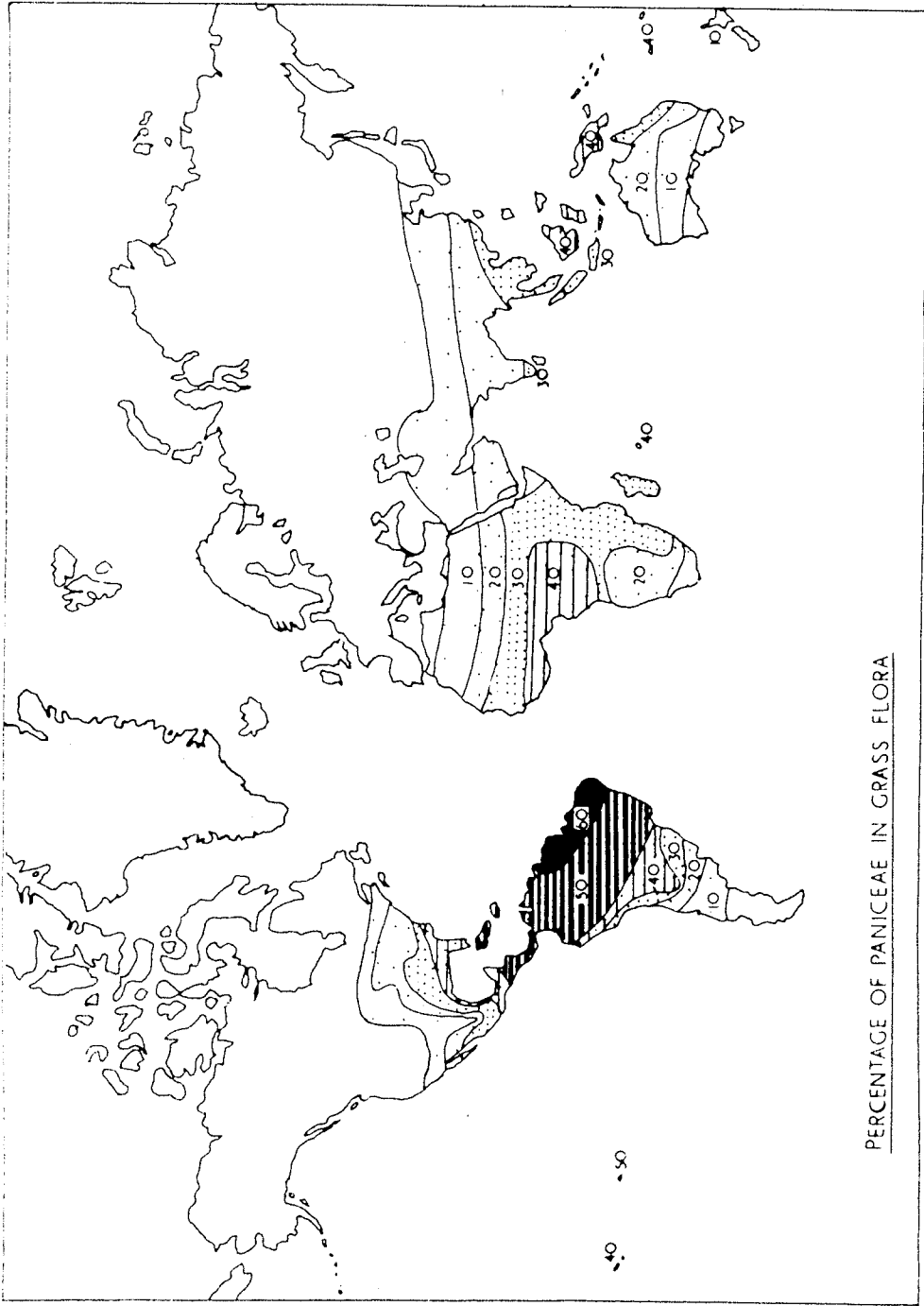

PERCENTAGE OF PANICEAE IN GRASS FLORA

FIGURE 24

Second, although many major collections had been made previously, the earliest collections of A. compressus from the non-American areas are dated between 1840 and the present. For example, at least eight collectors had worked on the flora around Cape Coast, in Ghana, from 1697 to the time Barter collected the first specimen of A. compressus in 1842. Beauvois himself collected in the area in 1786. By contrast, a great number of collections had been made in America prior to 1850. Today, A. compressus is a very conspicuous component of the weed floras throughout West Africa, hence it is difficult to imagine why early collectors failed to collect specimens - unless there were none. It might be reasoned that before the first collections were made it was a much less conspicuous weed because there were fewer and smaller towns and villages and fewer suitable habitats. This might be true for the high forest zones and arid zones, but for the greater part of West Africa, village clearings and networks of pathways provided habitats in which the itinerant collector could scarcely have failed to observe any Axonopus which might have been present. The weight of circumstantial evidence favours the view that it was not present until after 1790. It was not until then that the flow of slaves from Africa to America was reversed; the first to return direct from the Bahamas arrived in 1792; they came from Jamaica in 1799, and the flow increased after the abolition of slavery in 1807.

Like most other tropical people, the African relies upon grain crops for at least part of his staple diet. Since the grain is sun-dried by spreading it upon the ground, it is possible that some Axonopus seed may accidentally become mixed with it. Grain carried as provisions for the journey from America, or as seed, might thus have included Axonopus seed. This method of transport could have played an important part in the spread of Axonopus in many other tropical areas.

Assuming that dispersal was by means of seed, it may appear remarkable that A. compressus - sensu lato - is the only tropical American species to attain a widespread distribution. This is the only species complex which is present in the islands and coastal areas of the Caribbean Sea and Gulf of Mexico. The majority of species occur in the interior of southern tropical America. Herbarium specimens which have been examined from the Caribbean area, include some which the writer has determined as A. brevipedunculatus. A. affinis is common on the northern side of the Gulf of Mexico.

The recognition of discrete taxa within the complex in America (e.g. the variety jesuitica Araujo, and A. affinis Chase), and particularly of variation in chromosome number (see page 69), indicate that the complex is in a dynamic condition there. It is impossible to assess how much of such variability might have accompanied the earliest materials brought to West

Africa, but three aspects of the present West African populations are significant in this respect. First, there was no record of A. affinis anywhere in West Africa before 1940. It may have been introduced at about that time by Americans concerned with the rubber plantations in Liberia. Its great success in Sierra Leone since its introduction for this present work suggests that, had it been introduced earlier, it would have now been widespread. As this is not the case, it would appear unlikely that it had been introduced on a previous occasion. Second, A. flexuosus occupies very restricted habitats on seasonal floodplains, marshes and river banks in the coastal territories from Guinea to the Congo, and on marshes and river banks around the great lakes of East and Central Africa. The inland populations are connected with the coastal ones by isolated populations along the Congo River (Eala, Coquilhatville, etc.). The first record from the Congo is the specimen collected in 1888 by Hens, and it seems possible that its spread inland may have been made possible by the well developed river, road and rail systems which have encouraged human migration as well as facilitating exploitation of mineral deposits. Third, the cytological variety reported for American material has its parallel in the African material. This suggests that cytological variability existed in the first materials brought to West Africa.

These are all speculative considerations but they pro-

vide the initial assumptions that Axonopus was introduced into Africa in fairly recent times, it was introduced as seed, and the seed was from parents which were probably morphologically and cytologically variable.

The West African species differ in their ecological requirements. A. arenosus is only known from sandy maritime habitats in which it experiences soil salinity, or physiological drought, and burial by the loose sand. A. flexuosus is confined to habitats which experience at least seasonal flooding. Its populations are widely separated from each other. Even during the dry season the supply of water from the soil in these habitats is sufficient for this species to persist as a turf. A. brevipedunculatus is the most weed-like species, occurring on bare ground in villages and on farms. In such habitats it experiences great extremes of daily temperature change and seasonal water supply.

The differences between the species are not only ecological, but also those of morphology, chromosome number and breeding mechanism. The morphological differences between the species and natural hybrids support the proposed taxonomy. The differences which are found in plants from wild populations persist when the plants are grown together under experimental conditions. The morphological changes which result from exposure

to different environments, or mowing, or from seasonal changes, indicate that certain characters are much more variable than others. Amongst such variable characters are some which have been afforded taxonomic significance. The spikelet lengths recorded for plants grown under different shading conditions, and for plants at different times of the year, show that this character is influenced by the environment. In the same way leaf size and culm length are also modified by the environment and by mowing. Such changes reduce the precision with which the taxa can be separated on the basis of single characters, but they do not make their separation impossible. For example, the spikelet length of A. compressus x flexuosus varies from 2.7 to 4.0 mm and that of A. brevipedunculatus varies from 2.8 to 3.4 mm. This overlap does not make it impossible to distinguish between live plants, or herbarium specimens, or even single spikelets of these two taxa, by the use of other characters.

The variation detected in chromosome numbers consists of changes involving the presence of additional chromosomes and of changes involving polyploidy.

Variation in chromosome number within clones, within a single plant and even within a single spikelet or root meristem has been demonstrated by several authors (Håkanson, 1954, Milinkovic, 1957, Müntzing, 1948, Nielson, 1959, Nygren, 1958, Guildenhuys and Brix, 1958). The variations include trisomics

involving one or several chromosomes, somatic doubling of the whole or only part of the chromosome complement, chromosome fragmentation and the presence of B-chromosomes. The B-chromosomes have little or no homology with the somatic or A-chromosomes and they can give rise to somatic mosaics, in which the somatic numbers differ as much as sevenfold, through non-disjunction. The origin of the B-chromosomes is uncertain, but they are thought to originate through fragmentation followed by linear rearrangement of the A-chromosomes. This is then followed by heterochromatinisation (Avdulov and Titova, 1933, Darlington, 1963, Cleland, 1951, Reese, 1954, Lewis, 1951, 1953, Bosemark, 1957) in a manner similar to the differentials of sex chromosomes (Melander, 1950, Virkii, 1954, Vaarma, 1953, Sorsa, 1956). The extent to which they may be caused by handling during the making of preparations is uncertain. Examples are known of additional chromosomes which are morphologically indistinguishable from the A-chromosomes. The behaviour of the B-chromosomes during meiosis is not predictable (Mochizuki, 1957) but they are known to cause stickiness of the first metaphase, irregularities of disjunction and even non-disjunction. These irregularities are commonly confined to microsporogenesis and cause variation in gametic chromosome numbers. When there is partial pairing with the A-chromosomes the meiotic divisions may occur precociously or be retarded.

No detailed investigation has been made of the morphology of the chromosomes in the present work. The meiotic behaviour of some plants of A. compressus suggests that they have B-chromosomes. Because of the uncertainty concerning the true nature of the quadrivalents recorded (Table 10) it can not be said whether or not the B-chromosomes have any homology with the A-chromosomes. In some plants of A. brevipedunculatus the presence of two extra chromosomes has earlier been attributed to fragmentation or to their being B-chromosomes. The presence of two meiotic univalents in such plants suggests that their being B-chromosomes is the more likely explanation.

In the natural hybrid A. compressus x flexuosus the diploid numbers recorded suggest that these plants arose from crosses between $2n=40$ and $2n=60$ parents. The presence of up to four extra chromosomes in some plants again suggests that these are B-chromosomes. The diploid number of 48, however, requires some other explanation. The population (Leicester) from which these $2n=48$ plants were collected has been sampled on several occasions. No $2n=60$ plants have been found in or near the population. It seems unlikely that this population has arisen from a cross between $2n=40$ and $2n=60$ parents, but that it is a population in which B-chromosomes have accumulated. This problem is still under examination and a certain amount of evidence (not presented here) has been obtained, which indicates that

chromosome number varies within a single plant. If this is the case, it would explain the irregularities of pollen meiosis and its products; since pollen mother cells with many B-chromosomes have more irregular meiosis than those with few, and produce a higher proportion of micronuclei.

The species examined form a polyploid series. Since the genus also contains species with $2n=20$ (A. scoparius and A. iridaceus) A. compressus and A. brevipedunculatus must be regarded as tetraploids, A. flexuosus and A. arenosus as hexaploids and the introduced American species, A. affinis, as octoploid. The meiotic behaviour of all these species is regular and they are all highly fertile. As no evidence of intergeneric hybridisation has been obtained from any of the present investigations, these species must be assumed to have only infrageneric or even infrasectional relationship to each other. Their amphidiploid behaviour indicates that either the pairing of their chromosomes is genetically controlled or their chromosome complements consist of several different genomes. These points will be considered later. Not only do they fall into three cytotaxonomic categories, as determined by the degree of polyploidy, but the irregularity of meiosis in the artificial A. compressus x A. brevipedunculatus hybrid indicates that the two species concerned are also cytotaxonomically distinct. No equivalent information has been obtained for the two $2n=60$

species, A. flexuosus and A. arenosus.

The breeding mechanisms of the four West African species present additional barriers to hybridisation besides those of distribution and differences in cytology. Evidence has been obtained of an apomictic breeding mechanism in three of the species, A. brevipedunculatus, A. flexuosus and A. arenosus.

Cytological confirmation of the mechanism by which apomictically formed seeds are produced has only been obtained for the first of these species. Other evidence indicates that the remaining two species probably produce seed by the same apomictic process.

Apomicts present both taxonomic and nomenclatural problems. The taxonomic problems stem from different views concerning the definition of the species. When the discovery of an apomictic breeding mechanism follows the recognition of the species by orthodox, morphological standards, the view that the species consists of an agamic complex is generally acceptable. At the other extreme, the splitting of a species group into a number of new species on the basis of the discovery of component apomictic groups is often strongly criticised. In the case of such extensively investigated genera as Rubus, Hieracium, Taraxacum and Poa there may be a strong case for the adoption of new nomenclatural principles (trinomial, microspecific status prefixes or apomictic status prefixes) which would not, perhaps, satisfy the orthodox taxonomist, but would be of bene-

fit to the monographer and experimental worker. For general compilation of floras, however, apomicts are considered too demanding on space to warrant full recognition or are excluded entirely (together with ecospecies) (Valentine and Heywood, 1961, Walters, 1959). In general, it is reasonable to reserve the rank of species for groups of organisms which can be defined morphologically, and it was for this reason that the apomicts dealt with here were given specific status. Not only do they differ morphologically, but they are isolated from each other by differences in chromosome number and breeding mechanisms and distributions; hence, it is considered reasonable that they be afforded the rank of species. It may be that in the future other apomict groups may be discovered within the complex. Amongst the herbarium materials which have been examined, were a number which could be determined as A. brevipedunculatus, but which differed in minor morphological details. These may have been due to responses to different growing conditions, but the presence of fruits in the spikelets within the ultimate leaf sheath indicated that the plants were apomictic.

In its spread through West Africa Axonopus has benefited from being a ruderal weed. A. compressus is a characteristic plant of bush paths, which form the arterial system of vast areas of West Africa. Along these paths the seasonal changes in water supply and the diurnal changes of temperature

are much smaller than in more open habitats. A. compressus seeds are more likely to be accidentally carried by man and animals along these paths than they would be in open habitats. The other three West African species may have evolved from ecotypes which were better adapted to life in the habitats now occupied by these species, but it is impossible to say whether these early stages took place after introduction into West Africa, or whether they had already occurred amongst the American ancestors. It is unlikely that the entire process of speciation was complete before introduction. If it was, the same species should now be present in the Caribbean area, but only A. compressus, A. affinis and A. brevipedunculatus are present there. Ecological specialisation has undoubtedly occurred, but the more important changes which have taken place are those involving change in chromosome number and breeding mechanism.

Clausen (1961) reviewed the evolution, distribution and ability to hybridise of the genus Poa. He suggested that because long separated groups could be crossed to give hybrids which were usually fertile, the genus had preserved a state of 'evolutionary youthfulness' through polyploidy and apomixis. Poa hybrids derive their fertility either from a high degree of homology between the genomes of their parents, or from seed production through apospory or adventitious embryony. One con-

sequence of this sustained fertility is that B-chromosomes have accumulated and are transmitted to and maintained in the hybrids (Håkanson, 1954, Milinkovic, 1957, Muntzing, 1948, Nygren, 1958, Skalinska, 1959). Axonopus has been investigated much less than Poa, but what is known about the genus suggests that there are certain features common to both these genera. The range of chromosome numbers which have been recorded for South American Axonopus species suggests that B-chromosomes and polyploidy are common. Apomixis in Poa ensures that the hybrid genotype is passed on to the offspring, without addition or deletion. In Axonopus apomicts the genotype of the seed parent is passed on to the offspring. If, however, the seed parent was heterozygous, the offspring only inherit a homozygous genotype.

The term amphidiploidy (Clausen, Keck and Hiesey, 1945) was coined to describe all polyploids derived from parents which were separated at the diploid level by hybrid sterility, and does not apply to hybrids from crosses such as Poa caespitosa x P. arachnifera which have full chromosome pairing. Functional diploidy means that reproduction by seed is possible because full chromosome pairing occurs - regardless of whether the plant is diploid or polyploid. The ability of the chromosomes to pair is now known to be controlled either by the degree of homology or by genetic means. In amphidiploids proper, functional diploidy is achieved when the hybrid genotype is

doubled. In the case of Triticum (Sears and Okamoto, 1957, Riley, 1960) pairing occurs only between chromosomes of the same parental genome (A with A, B with B and D with D) because of the regulatory effect of a segment of one of the chromosomes (5, in the B genome).

The five species of Axonopus which have been investigated are all functionally diploid. Since two of the species are tetraploid, two hexaploid and one octoploid, it seems most probable that pairing of their chromosomes is genetically controlled. The meiotic irregularities in the natural and artificial hybrids appear to confirm this view. These irregularities include 'stickiness', the formation of multivalents, the formation of a high proportion of bivalents and some quadrivalents and the formation of a high proportion of bivalents with some univalents. In the natural hybrids, some of the irregularity may be due to the presence of B-chromosomes, but in the artificial hybrids none of the parents had B-chromosomes, and the irregularities suggest the loss of genetic control over pairing. In the artificial hybrids also the meiotic behaviour indicates that there is considerable homology between the parental genomes, but that they differ in chromosome structure.

The evolution of these Axonopus polyploids can be considered in theoretical terms only. The simplest explanation for the origin of the tetraploid condition is that chromosome doub-

ling occurred in a sterile hybrid between two diploid ancestors. The new allotetraploid may have achieved functional diploidy by one or a combination of the following:-

1. as the initial consequence of chromosome doubling, as in Raphanobrassica (Karpechenko, 1927);
2. through chromosome recombination in succeeding generations;
3. through chromosomal reorganisation assisted by vegetative reproduction, or
4. through chromosomal recombination brought about as a consequence of the adoption of an apomictic mode of reproduction.

The first of these processes would depend upon the amount of homology between the two genomes of the hybrid, but if it gave an allotetraploid condition which permitted only reduced sexual reproduction, the second process may have further assisted in arriving at the functional diploid state. Pressure of natural selection may have favoured chromosome recombinants in a way analogous to that by which crop plants are improved by artificial selection (Heinz, 1962). Chromosomal reorganisation would depend upon a long sequence of interchanges taking place. These may have been multiplied by vegetative reproduction and selected in sexual reproduction. The process would have to have been prolonged, and would probably have led to the evolution of many more species than have actually been recorded, at this level of

polyploidy. The adoption of an apomictic mode of reproduction may have permitted the achievement of functional diploidy in one or a few generations, depending upon the kind of apomixis and the regularity of the first meiotic division. Apospory and adventitious embryony would only preserve the original allotetraploid condition. Diplospory, in which pairing and crossing-over occur, but reduction does not, may have permitted some chromosomal reorganisation. Automixis, provided that the meiotic reduction resulted in fairly balanced products, would rapidly have selected a tetraploid chromosome complement composed of two homologous sets.

The hexaploids could have arisen by chromosome doubling of a sterile triploid or by union of reduced and unreduced gametes from a tetraploid. The octoploid could have arisen by chromosome doubling of a tetraploid, or from a hybrid between two tetraploids, or by union of a reduced gamete from a tetraploid and an unreduced gamete from a hexaploid (Darlington, 1963, Riley, 1957, Stebbins, 1956). Whichever processes may have been involved, the final products are functional diploids, and apparently have their own distinct chromosome complements. The sterility barriers which have been found between some of these species are reinforced by differences in distribution and breeding mechanisms.

The susceptibility of grasses to changes in reproductive behaviour, in habitats which approximate to the extremes of their tolerance, is well known. A consequence of adaptation to non-optimal conditions is that suitable phenotypic variants are favoured by natural selection and this facilitates the production of new genotypic variants. Apomixis in grasses is common (Atwood, 1947, Bashaw and Holt, 1958, Bashaw, 1962, Borgaonkar, 1957, Brown and Emery, 1957, 1958, Burton, 1962, Carnahan and Hill, 1961, Celarier and Harlan, 1957, Emery, 1957, Farquharson, 1955, Fisher, Bashaw and Holt, 1954, Gildenhuis and Brix, 1958, Hair, 1952, Hayman, 1956, Narayan, 1955, Nygren, 1951, 1954, Powers, 1944, Skalinska, 1959, Snyder, 1957, Warmke, 1954) but little is known about its causes. Bashaw and Hoff, (1962), Burton (1962) and Julen (1960) have found that X-rays and other ionising radiations effect changes in the frequency with which apomictic offspring are produced by Paspalum and Poa. Knox and Heslop-Harrison (1963) have shown that light regime determines the production of either reduced or unreduced embryo sacs in Dichanthium aristatum (Poir.) Hubbard. In Poa the incidence of apomixis bears no relation to chromosome number but it is commonly associated with polyploidy. It is a phenotypic response to the environment in species at the limits of their ecological distribution, but is also regulated genetically. The progeny of facultative apomicts segregate as predominantly

sexual or predominantly apomict, as though apomixis were controlled by either one or several genes.

The apomictic species of Axonopus are more tolerant of habitats with a greater daily and seasonal change of temperature and water supply. In the exposed habitats occupied by the apomictic A. brevipedunculatus, diurnal changes in surface soil temperature range between 6°C and 85°C and direct insolation may have a duration of 10 hours daily. By contrast, the bush path habitats of the sexually reproducing A. compressus experience very small temperature changes around an ambient of 23°C and direct insolation may never occur, or occur for brief periods when the tree canopy is broken. The morphology of the flowering stems suggests that selection for apomixis has been paralleled by selection for short peduncles. The mechanical prevention of anthesis in spikelets which remain enclosed in the ultimate leaf sheath may have contributed to selection for apomixis.

The general view of apomixis in the Panicoid grasses is that they are aposporous (Carnahan and Hill, 1961). It is based upon a survey (Brown and Emery, 1957) in which four-nucleate embryo sacs were regarded as being unreduced and eight-nucleate embryo sacs were regarded as being reduced. Snyder (1957) found this criterion to be unreliable, since the eight-nucleate embryo sac in Paspalum secans Hitchc. and Chase is

aposporous. Also, Gildenhuis and Brix (1958) found that the four-nucleate embryo sac of Pennisetum dubium Gildenh. and Brix can be reduced, having degenerate antipodals and fused polar nuclei.

In Axonopus the chromosomes of the archesporial cell pair fully, and meiosis gives rise to a T-shaped tetrad of megaspores. The innermost megaspore is therefore haploid, and all the nuclei which are produced from it by mitosis, must have the same haploid genotype. The division of the two micropylar nuclei of the four-nucleate stage differs. One nucleus divides normally to produce a nucleus which forms a synergid and another which becomes one of the polar nuclei. The second nucleus undergoes chromosome division, so that two large nucleoli are observed, but the products are contained within a single nucleus. Unlike accounts of facultative apomixis, it is not necessary here to resort to statistics of the number of stages recorded. All the archesporial cells, observed in division, had paired chromosomes at diakinesis and first metaphase; all the early embryo sacs observed were associated with the remains of the degenerating megaspores; all the mature embryo sacs, except the sporous ones, were seven-nucleate and had the pro-embryo initial in the characteristic lateral position; no pollen germination was observed and no signs of pollen tubes or gametes was found in the embryo sacs; few spikelets failed to set fruit.

Since the embryo sacs which develop from reduced megaspores contain haploid nuclei of the same genotype as the megaspore, the pro-embryo initial can only have a completely homozygous diploid constitution. Automixis is therefore a very highly specialised reproductive system, but it would be wrong to regard it as an evolutionary cul-de-sac. Thomas (1940) has outlined the significance of the homozygotization which automixis occasions in the progeny, but some evolutionary aspects are worthy of consideration here.

In sexual populations, a balanced reserve of heterozygosity is maintained through segregation and recombination. Such populations always contain a large array of genotypes. The pressure of natural selection tends to eliminate the least favourable genotypes, but the alleles, which make these genotypes less favourable, are guarded against selection when in the heterozygous condition. They are never completely eliminated from the population. Other forms of apomixis also allow the maintenance of unfavourable alleles either by the production of the embryo from somatic cells, or by circumventing the meiotic reduction division, by which such alleles might be excluded from the reproductive cells.

High selection pressure, on an organism which has approached the limit of its ecological tolerance, favours a much smaller variety of genotypes. The sexual mode of reproduction

then becomes less efficient as a means of maintaining the population within the limits of the new range of genotypes. This is not necessarily true in the case of annuals or ephemerals, in which a wide range of genotypes are produced during a short, favourable season of the year. Vegetative reproduction has a selective advantage under these circumstances, though it maintains unfavourable genotypes. Also it fails to afford the same advantages for further spread which are associated with reproduction by seed. Selection for apomixis ensures that the ability to reproduce by seed is retained.

There are two important processes in the sexual production of seed. First, there is the formation of haploid eggs and secondly the reintroduction of the diploid condition by fertilisation of these eggs by haploid male gametes. In apomixis the production of a haploid egg is replaced by the production of a diploid pro-embryo initial, and this avoids the necessity for fertilisation. Since reduction and fertilisation are the processes by which genetic segregation and recombination occur, the apomictic mode of reproduction does not allow the production of as wide a variety of genotypes. It leads to the production of populations in which one or several characters become fixed and which may be regarded by some as sufficient to warrant taxonomic recognition (especially if the character concerned affects the form of the flower or inflorescence). Recom-

bination is never completely eliminated in apomictic populations but it is always reduced. Variation may arise if the apomictic lines evolve separately from sexual crosses, or from hybridization between facultative apomicts, or from gene and chromosome changes taking place in the apomict itself. In automixis variation is restricted to the separate evolution of automictic lines and to gene and chromosome changes. In meristems which give rise to inflorescences any gene mutation, or change in chromosome structure, will be rendered homozygous in the automictically produced offspring. If these changes affect the morphology of the plant, then they will be apparent in the phenotype. In other forms of apomixis, such mutants are maintained in the heterozygous condition.

One important aspect of the lowering of the recombination rate is that it maintains genetic control over the apomictic processes themselves. These processes include the production of a diploid pro-embryo initial, the development of the pro-embryo initial (in autonomous apomicts) without the stimulus of ^{pollination} ~~pollination~~, and the development of the endosperm without fertilisation. Since crosses between sexual and apomictic species give hybrids which are sexual, and from which apomicts segregate in later generations, the genetic control of the apomictic mode of reproduction is regarded as being recessive to the control of sexuality. The hybrids obtained from

the cross A. compressus x A. brevipedunculatus showed no indication of being able to reproduce apomictically, despite their meiotic irregularities, and this suggests that automixis in A. brevipedunculatus is controlled by recessive genes in the homozygous condition. This also suggests that the origin of the automictic mode of reproduction was the selection of recessive alleles. These regulated the three processes, mentioned above, when in the homozygous condition. This could have been achieved when the sexual progenitor, probably A. compressus, spread into habitats in which the pressure of natural selection was sufficiently high to favour only a small array of genotypes.

Automixis, together with a genetic control of chromosome pairing, offers a possible explanation for the evolution of hexaploids. Union of reduced and unreduced gametes from tetraploids, or the chance fertilisation of a pro-embryo initial by a reduced gamete from a tetraploid, would give the hexaploid state. Homozygotization, of the alleles concerned with the control of automixis, could then have occurred as a consequence of the greater representation which those alleles would have in the hexaploid, than in the tetraploid. This would depend upon the degree of dominance of the sexuality alleles over the automixis alleles.

There appear to be two lines of relationship amongst

the species investigated. A. compressus, A. flexuosus and A. affinis more closely resemble each other, in the arrangement of their inflorescences and their sexuality, than they resemble the two remaining species, A. brevipedunculatus and A. arenosus. A. flexuosus is capable of producing some fruit when emasculated, but its free flowering in natural populations suggests that it is probably a facultative apomict. A. brevipedunculatus and A. arenosus flower much less freely in natural populations and it is assumed that the shortness of the peduncle is associated with obligatory apomixis, in these species.

The two lines of relationship are represented in the diagram below. The diagram is not intended to present a complete summary of the evolution of the five species, but attempts to illustrate the probable relationships between them and the natural hybrids.

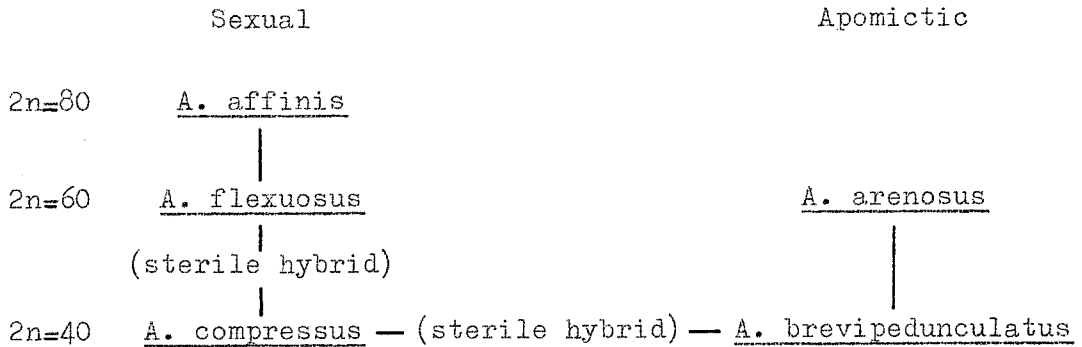

Summary.

The genus is defined in the terms proposed by Chase (1911), and variation in the genus is outlined briefly. A short account is given of the history of the taxonomy of the Axonopus compressus (Sw.)Beauv. complex, and seven taxa are proposed for West Africa.

These are: A.compressus (Sw.)Beauv.

A.brevipedunculatus Gledhill, sp.nov.

A.flexuosus (Peter) Hubbard ex Troupin

A.arenosus Gledhill, sp.nov.

A.affinis Chase

A.compressus x flexuosus Gledhill, hyb.nov.

A.brevipedunculatus x compressus Gledhill, hyb.nov.

A.affinis was introduced from America and Australia, by the writer.

Accounts are given of investigations on the morphology, anatomy, cytology and breeding mechanisms of the taxa, and of the artificial hybrids from three separate crosses. The breeding mechanism of A.brevipedunculatus is described as automictic (Thomas, 1940).

It is suggested that Axonopus evolved in South America, and was probably brought to West Africa by liberated slaves.

The taxonomy is considered in terms of the differences in ecological requirements, morphology and morphological variation, cytology and breeding mechanisms. The evolution of polyploidy and apomixis is discussed, and the parts played by these in the evolution of the West African taxa are considered. The species examined represent three levels of polyploidy, and can be arranged as two lines of relationship. One line is sexual, and the other apomictic.

Appendix 1.

The following artificial key has been designed to separate Axonopus from genera which are either closely allied to it, or whose names have been confused with it. In attempting to keep it simple, yet explicit, the names of many genera have not been included. Some of these genera would in fact run out at certain points in the key.

1. Spikelets 2-flowered, falling entire at maturity, usually with the upper floret hermaphrodite and the lower male or barren, and if the latter often reduced to the lemma or, rarely, the lemma entirely absent, all alike or differing in size and shape and structure, frequently dorsally compressed. 2.

Spikelets 1- to many-flowered, breaking up at maturity above the more or less persistent glumes, or if falling entire then not 2-flowered with the lower male or barren and the upper hermaphrodite, usually more or less laterally compressed.

Milium and sub-family Pooideae.

2. Glumes membranaceous, the sterile lemma like the glumes in texture. -3.

Glumes indurate, the sterile lemma like the fertile one, the fertile lemma and palea hyaline or membranaceous.

(Tripsacaceae and Andropogoneae).

3. Fertile lemma and palea indurate or at least more firm than the glumes. 4.

Fertile lemma and palea thinner than the glumes, sterile lemma awned from the notched apex. (Melinideae)

4. Spikelets not recessed in cavities along the rachis. 5.
Spikelets recessed along the rachis, the latter corky and dis-
articulating at maturity. Stenotaphrum.
5. Fruit chartaceous-indurate, rigid. 6.
Fruit cartilaginous-indurate, flexible. Digitaria.
6. Spikelets abaxial. 7.
Spikelets adaxial. 9.
7. One or both glumes present, fruit not long-acuminate. 8.
Both glumes wanting, fruit long-acuminate.
Reimarochloa.
8. First glume present, spikelets usually in panicles.
Panicum.
First glume typically wanting, spikelets sub-sessile in spike-like
racemes, plano-convex. Paspalum.
9. First glume present or wanting, not forming a ring-like callus
below the spikelet. 10.
First glume and the rachilla joint forming a ring-like callus below
the spikelet. Eriochloa.
10. First glume present, its back to the axis, up to $2/3$ the length of
the spikelet, racemes racemose along the main axis.
Brachiaria.
First glume wanting, racemes digitate or sub-digitate.
Axonopus.

Some of the differences between Axonopus and related genera are set out in the following table.

	Spikelet orientation and disarticulation	Glumes	Lower palea	Inflorescence
<u>Milium</u>	abaxial. above glumes	equal	absent	paniculate
<u>Panicum</u>	abaxial. below glumes	unequal	present	
<u>Digitaria</u>	..	unequal or 1st wanting	obsolete	digitate racemes
<u>Paspalum</u>	absent	..
<u>Stenotaphrum</u>	..	unequal	present	solitary racemes
<u>Reimarochloa</u>	..	wanting	obsolete	digitate racemes
<u>Eriochloa</u>	adaxial. below glumes	unequal or 1st wanting	present	approximate racemes
<u>Brachiaria</u>	..	unequal
<u>Axonopus</u>	..	1st wanting	absent	digitate racemes

History of the genus Axonopus Beauv..

This short account of the history of the genus is mainly concerned with the stages by which the genus came to be established upon the type species, Axonopus compressus (Sw.) Beauv.. More detailed accounts can be found in the works of Chase (1911), Dedecca (1956) and Black (1963).

Beauvois' citation of four species, as being representative of the genus, presented later workers with more than the task of justifying the erection of the genus. Beauvois expressly left this task to posterity. The four species which he cited differ amongst themselves in several important respects. These include differences in structure of the spikelets and inflorescences.

Several of the earlier workers modified the taxonomy of the genus Paspalum Linn., in such a way as to include some of the species cited by Beauvois into that genus. Thus, Nees (1829) proposed six sections in the genus Paspalum, and three of these contained many species which are now regarded as being species of the genus Axonopus. One such species was Paspalum compressum Rasp.. Doell (1877) gave Axonopus as a synonym for his section Cabrera, of the genus Paspalum. Schlechtendal (1850, 1877) raised Nees' section Digitariae, which contained Paspalum compressum Rasp., to generic status. He gave this genus the nomen Anastrophus. Hæckel (1887) reverted to the Paspalum concept. His third section of that genus was composed of members which had the second glume and fertile lemma turned away from the axis of the inflorescence.

Apart from the major digression by which Hooker (1896)

reverted to the separate genus, Axonopus, which in his view was based on Milium cimicinum Sw., and its adoption by Stapf (1896), subsequent revisions of the genus Paspalum and related genera have brought together Lagasca's (1816) genus Cabrera, Steudel's (1854) genus Lappagopsis and Beauvois' (1812) genus Axonopus as a single genus, based upon Milium compressum Sw..

Nash (1903) employed Schlechtendal's name, Anastrophus, for this alliance, but Hitchcock (1906) adopted the earlier name, Axonopus. The full justification of the genus must be attributed to Chase (1911). Her review not only clarifies the case for establishing the genus upon Milium compressum Sw., but also includes a note on the heterogeneity of the type species itself.

Synonymy, descriptions and distributions of the West African species
and natural hybrids.

Axonopus compressus (Sw.) Beauv.

Milium compressum Sw. (Prodr. 24.1788 and Fl. Ind. Occ. 1:183.1797)

Paspalum tristachyum Lam. (Tabl. Encycl. 1:176.1791)

Paspalum platycaulon Poir. (Encycl. Suppl. 5:34.1804)

Agrostis compressa Poir. (Encycl. Suppl. 1:528.1810)

Paspalum compressum Rasp. (Ann. Sci. Nat. 1, 5:301.1825)

Paspalum laticulmum Spreng. (Syst. Veg. 1:245.1825)

Digitaria platycaulis Desv. (Opusc. 62.1831)

Paspalum guadaloupense Steud. (Syn. Pl. Glum. 18 and 20.1855)

Paspalum depressum Steud. (Syn. Pl. Glum. 112.1855)

Anastrophus compressus Schlecht. (Bot. Zeit. 8:681, 1850)

Anastrophus platycaulis Schlecht. (Ind. Kew. 1:118.1893)

Panicum platycaulon Ktze. (Rev. Gen. Pl. 3:363.1898)

Paspalum raunkiaerii Mez (Fedde Rep. 15:60.1917)

Perennial, up to 30 cms tall, forming small tufts and solitary culms from slender rhizomes. Stolon internodes c. 5 cms long, 1.3 mm wide, compressed and double keeled adjacent to the innovation below. Culms slender, ascending or erect. Sheaths 3 mm wide, compressed, glabrous or ciliate on the margins below the insertion of the blade. Blades 2.5 - 16 cms long, (3-)6 - 10 mm wide, linear-lanceolate from a rounded base, asymmetrically rounded at the apex, flat or folded along the conspicuous midrib, bright green, glabrous or sparsely ciliate, the margins ciliate with hairs 1 - 1.5 mm long and 0.2 mm apart and with hyaline teeth interposed between them. Nodes glabrous to hairy, with white hairs 1.5 mm long. Inflorescences 2 - 3, each with 2, 3 or rarely 4 spreading, spike-like racemes. The first raceme

terminal, the second sub-terminal, and the third about 2 cms below (rarely, the third raceme is also sub-terminal). Peduncles 0.7 mm diameter, glabrous, triquetrous, much longer than the ultimate leaf sheath. Racemes 5 - 7 cms long, slender, straight. Rachis glabrous, triquetrous, smooth or slightly scaberulous at the margins. Pedicels alternating in slight depressions at each side of the abaxial margin. Spikelets 1.9 - 2.4 mm long, 0.7 mm wide, oblong, obtuse to sub-acute, green or slightly anthocyanosed, slightly or sometimes strongly white silky-hairy. Hairs appressed or spreading at the base of the spikelet. Second glume corresponding in size and shape to the spikelet, bluntly apiculate, with minute hyaline projections near the apex, 5 or 4 nerved. Nerves faint, the inner pair with one rank of hairs within and the outer pair flanked by hairs on each side. Sterile lemma subsimilar to the glume, but embraced by it marginally. Fertile lemma and palea subsimilar, 1.6 mm long, the former with an apical tuft of hairs and embracing the latter marginally, crustaceous and minutely rugose. Anthers 0.5 mm long, white to pale mauve with darker mauve margins. Stigmas white to pale mauve. Fruit 1.3 mm long, 0.6 mm wide, elliptic-obtuse, yellowish-white. Embryo occupying the lower third of the grain. Hilum small oval.

Axonopus flexuosus (Peter) Hubbard ex Troupin. (Fl. Parc Nat. Garamba 1.4:18.1956)

Digitaria flexuosa Peter (Fedde Rep. 40:165.1930)

Axonopus compressus var *jesuitica* Araujo (Bol. Secret. Est. Negoc. Agr. Ind. & Comm. 100:36.1943)

Axonopus compressus subsp. *congoensis* Henr. (Blumea 5:529.1945)

(*Axonopus africanus* Hubbard illegitimate)

Perennial, up to 60 cms tall, forming a deep matted sward of stoloniferous growth. Stolons at first erect, becoming long-arched and rooting, inter-

nodes up to 30 cms long, 6 mm wide, compressed and obtusely double keeled. Culms stout, erect or geniculately ascending. Sheaths up to 6 mm wide, compressed, smooth, glabrous. Lower sheaths 2-8 cms long, crowded, long-flabellate. Leaf blades up to 30 cms long and 20 mm wide, linear to linear-lanceolate, obtuse to sub-acute, not markedly asymmetrically pointed, scarcely auricled at the base, flat or folded along the conspicuous mid nerve and principal lateral nerves, green to dark-green, glabrous, the margins with hyaline teeth only. Nodes glabrous. Inflorescences 3 - 5, each with 2, 3, 4 or 5 spike-like, narrowly spreading racemes; the interval between the lowest raceme and the upper ones (which may be inserted sub-conjugately) being 3 - 4 cms. Peduncles 0.8 mm diameter, glabrous, triquetrous, twice as long as the ultimate leaf sheath, or more. Racemes up to 16 cms long, flexuous, olive-green. Rachis glabrous triquetrous, minutely scarberulous on the margins. Spikelets 3.3 (- 4) mm long, 0.9 mm wide, narrowly ovate-lanceolate, sub-acute to acute, acuminate, glabrous or inconspicuously appressed silky-hairy. Second glume corresponding in size and shape to the spikelet, sub-acute, apiculate, with scattered hyaline projections near the apex. Sterile lemma subsimilar to the glume but embraced by it marginally and more convex. Fertile lemma and palea subsimilar, 2.0 mm long, 0.9 mm wide, thinly crustaceous and minutely rugose; the former with an apical tuft of hairs and embracing

the latter marginally. Anthers 0.7 mm long, linear, deep mauve. Stigma deep mauve. Fruit 1.9 mm long, 0.8 mm wide, elliptic obtuse, the embryo occupying the lower half of the grain. Hilum small, oval.

Axonopus compressus x flexuosus Gledhill, *hyb. nov.* (Article H.1 International Code of Botanical Nomenclature (1961) note 4 - the order of the epithets is alphabetical). Perennial, up to 60 cms tall, forming a deep mat of stoloniferous growth. Stolons at first erect, later arching and becoming rooted, internodes up to 8 cms long and 2.5 mm wide, compressed and sharply double keeled. Culms slender, erect or geniculately ascending, terminal and also lateral from the lower nodes. Sheaths compressed, up to 4 mm wide, striate, glabrous or slightly hairy on the margins below the insertion of the blade; lower sheaths up to 8 cms long, crowded, long flabellate. Leaf blades up to 45 cms long and 15 mm wide, linear to linear-lanceolate, obtuse to sub-acute, not markedly asymmetrically pointed, scarcely auricled, frequently folded along the principal veins, glabrous, the margins remotely ciliate towards the base but with hyaline teeth alone towards the apex. Nodes sparsely hairy; hairs 1.5 mm long. Inflorescences 3 - 4, each with 2, 3 or 4 spreading spike-like racemes. Peduncles glabrous, more than twice the length of the ultimate leaf sheath. Racemes up to 14 cms long, flexuous. Rachis glab-

rous, triquetrous, scarberulous on the margins. Spikelets (2.7 -) 3 (- 3.4) mm long and 0.9 mm wide, lanceolate, sub-acute to acute, appressed white silky-hairy. Second glume sub-acute apiculate, 5-nerved (the middle nerve obscure), with hyaline teeth towards the apex, embracing the sterile lemma marginally. Fertile lemma and palea subsimilar, 1.9 mm long and 0.8 mm wide, the former with an apical tuft of hairs and embracing the latter marginally. Anthers orange-brown with dark, punctate markings marginally, never turgid. Stigmas deep mauve. Fruits not known.

Axonopus brevipedunculatus Gledhill, spec. nov.

Axonopus compressus subsp. brevipedunculatus Gledhill

(Phytomorph. 12, 4; 412. 1962) pro parte.

Perennial up to 16 cms tall, forming a dense tufted turf with strongly rooting stolons and short, stout rhizomes. Stolon internodes up to 3 cms long, 2.2 mm wide, compressed and shallowly double keeled. Culms robust, terminal and solitary or in extravaginal groups from the innovations. Sheaths up to 6 mm wide, strongly compressed, with scattered long hairs on the margins and below the insertion of the blades. Lower sheaths 2 - 5 cms long, crowded, flabellate, smooth, striate, persistent. Blades (3.5 -) 12 (- 20) cms long, up to 13.5 mm wide, ovate-lanceolate from a rounded base, asymmetrically rounded at the apex, dark green or anthocyanosed, hispid on the upper surface and often corrugated

between the nerves, the margins undulate, ciliate with hairs 1.5 mm long on hyaline bases; the hairs 0.3 mm apart at the base but the interval increasing upwards such that in the upper third forward pointing hyaline teeth only are present. Nodes hairy; the hairs up to 1.8 mm long, white to pale mauve. Inflorescences 2, 3 or 4, each with 2 or 3 spike-like racemes. Peduncles 0.8 mm diameter, triquetrous, glabrous, seldom as long as the ultimate leaf-sheath. Racemes up to 6 cms long, strict, dark green or anthocyanosed. Rachis triquetrous, glabrous, scaberulous at the margins. Spikelets (2.6 -) 2.8 (- 3.4) mm long, 1.1 mm wide, broadly ovate-lanceolate, sub-acute, green or anthocyanosed, becoming stramineous, long silky-hairy; the hairs white to pale mauve, up to 1 mm long. Second glume corresponding in size and shape to the spikelet, sub-acute, with hyaline teeth towards the apex. Sterile lemma sub-similar to the glume but embraced by it marginally. Fertile lemma and palea subsimilar, 1.8 mm long, 0.8 mm wide, the former with a much reduced apical tuft of hairs and embracing the latter marginally. Anthers 0.6 mm long, yellow, becoming contorted and compressed by the growth of the caryopsis, seldom being exerted and then becoming crescentiform. Stigma white to pale mauve. Fruit 1.4 mm long, 0.8 mm wide, elliptic obtuse; the embryo occupying the lower half of the grain. Hilum small, oval.

a *A. compresso* (Sw.) Beauv. pedunculo folii terminalis

quam vagina raro multo longiore, inflorescentiis strictis, spiculis longioribus 2.8 mm, longis subacutis pilosis, stolonibus crassioribus, foliorum vaginis at laminis latioribus, laminis atroviridibus supra pilis rigidiusculis laxè dispositis apice saepe rubidis, folio terminale longitudine reducta differt; cuius exempla in collegio Fourasinense herbarioque Kewense reposita sunt.

Axonopus brevipedunculatus x compressus Gledhill, Hyb. nov.

Axonopus compressus subsp. brevipedunculatus Gledhill

(Phytomorph. 112, 4; 4. 1962) pro parte.

Perennial, up to 25 cms tall, forming a tufted, strongly stoloniferous turf in open, disturbed habitats. Stolon internodes up to 3 cms long, 2.3 mm wide, compressed and shallowly double keeled. Culms robust, branched, dark green or anthocyanosed. Sheaths compressed, up to 6 mm wide, lower sheaths up to 6 cms long, sparsely hairy on the margins and below the leaf blade, crowded, flabellate, persistent. Blades (3 -) 11.4 (- 20) cms long, 9.5 mm wide, ovate-lanceolate from a rounded base, asymmetrically rounded at the apex, dark green, usually becoming strongly anthocyanosed, hispid on the upper surface, the margins ciliate. Nodes hairy; hairs white to pale mauve. Inflorescences 2, 3 or 4, each with 2 or 3 spike-like racemes. Peduncles 0.8 mm diameter, glabrous, triquetrous, as long as or slightly longer

than the ultimate leaf sheath. Racemes up to 6 cms long, strict or slightly spreading, usually anthocyanosed. Rachis glabrous, triquetrous, scaberulous at the margins. Spikelets (2.5 -) 2.7 (- 3)mm long, 1 mm wide, ovate-lanceolate, sub-acute, anthocyanosed, becoming stramineous, silky hairy; the hairs appressed or spreading. Second glume corresponding in size and shape to the spikelet, sub-acute, with hyaline teeth towards the apex, embracing the sterile lemma marginally. Fertile lemma and palea subsimilar, 1.8 mm long, 0.8 mm wide, the former with a reduced apical tuft of hairs and embracing the latter marginally. Anthers dark mauve, seldom turgid. Stigmas mauve. Fruit unknown.

Axonopus arenosus Gledhill, sp. nov.

Perennial up to 20 cms tall, forming an open, tufted, stoloniferous turf on shaded, sandy, soils. Stolon internodes up to 5 cms long, 2.7 mm wide, slightly compressed and acutely but shallowly double keeled. Culms robust, ascending or erect. Sheaths 6 mm wide, compressed, glabrous, striate, widely flabellate. Blades (2.5 -) 11 (- 25) cms long, 15 mm wide, linear-lanceolate to oblong-lanceolate, from a rounded base, symmetrically rounded at the apex, light green, glabrous or with remote appressed hairs, the margins with few short hairs but with hyaline teeth. Nodes glabrous. Inflorescences 3 or 4 each with 2 or 3 strict or slightly spreading spike-like racemes. Peduncles

0.8 mm diameter, triquetrous, glabrous, the longest not much longer than the ultimate leaf sheath. Racemes up to 8.5 cms long, straight, light green. Rachis triquetrous, glabrous, smooth or slightly scaberulous at the margins. Spikelets 3 - 3.5 mm long, 1.1 mm wide, broadly ovate-lanceolate, obtuse at the apex, green, glabrous or with few, short appressed hairs towards the base. Second glume corresponding in size and shape to the spikelet, obtuse with hyaline teeth towards the apex, mid nerve conspicuous. Sterile lemma subsimilar to the glume but embraced by it marginally. Fertile lemma and palea subsimilar, 1.9 mm long and 1 mm wide, the former without an apical tuft of hairs, or the tuft much reduced, and embracing the latter marginally. Anthers brownish-mauve. Stigma mauve. Fruits 1.7 mm long, 0.9 mm wide, elliptic obtuse; the embryo occupying the lower half of the grain. Hilum small, oval.

a *A. compresso* (Sw.) Beauv. pedunculo folii terminalis quam vagina raro multo longiore; inflorescentis strictis vel suppatulis; spiculis longioribus, 3 - 3.5 mm longis, subacutis, glabris vel rarissimo pilo; nodis glabris; stolonibus crassioribus; foliorum vaginis et laminis latioribus; laminis glabris pallenti viriditate; folio terminale longitudine reducta differt. Cuius exempla in collegio Fourasinense herbarioque Kewense reposita sunt.

Axonopus affinis Chase.

Perennial up to 30 cms tall, forming tufts or spreading into a matted cover by slender rhizomes and short, many-noded stolons. Stolon internodes up to 3 cms long, 1.2 mm wide (seldom up to 2.5 mm), compressed and slightly double keeled, nodes glabrous to slightly white-hairy. Culms slender, erect or ascending. Sheaths 3 mm wide, compressed. Lower sheaths crowded, flabellate smooth or striate. Blades (4 -) 20 cms long, (3 -) 7 mm wide, linear, obtuse to sub-acute at the apex, flat or slightly folded along the mid nerve, glabrous or very sparsely ciliate, margins ciliate. Ultimate culm leaf 1.5 - 6 cms long. Inflorescences 2 - 3, each with 2 or 3 spike-like racemes. Peduncles 0.5 mm diameter, triquetrous, glabrous, much longer than the ultimate leaf sheath and often flexuous. Racemes 4 - 6.5 cms long, patent. Rachis triquetrous, minutely scabrid along the margins. Spikelets 2 - 2.3 mm long, 0.7 mm wide, oblong elliptic, slightly anthocyanosed, sparsely silky-hairy at the base and apex, with appressed hairs flanking the outer nerves of the second glume. Mid-nerves of the second glume and sterile lemma suppressed. Fertile lemma and palea subsimilar, 1.8 mm long, 0.7 mm wide, the former embracing the latter marginally but without, or with hardly any, apical tuft of hairs, crustaceous and minutely rugose. Anthers 0.5 mm long, pale mauve with darker margins. Stigma mauve. Fruits 1.7 mm long, 0.7 mm wide, ellip-

tic obtuse, yellowish white; the embryo occupying the lower half of the grain. Hilum small, oval.

Distributions

A. compressus - West Indies, French, British and Dutch Guiana, Venezuela, Columbia, Equador, Peru, Brazil, Bolivia, Paraguay, Argentina south to Tucuman, Panama, Costa Rica, Nicaragua, Honduras, Salvadore, Guatemala, South Florida, Louisiana, Hawaii, Japan, Malaysia, Indonesia, India, Assam, Seychelles, Natal, Zululand, East Transvaal, Swaziland, Congo, French Equatorial Africa, Tanzania, Cameroun, Nigeria, Dahomey, Togoland, Ghana, Ivory Coast, Liberia, Sierra Leone, Guinea and Gambia.

A. flexuosus - Guinea, Sierra Leone, Liberia, Nigeria, Congo, Kenya, Uganda, Tanzania, Zambia; also in Costa Rica, Singapore and Australia.

A. brevipedunculatus - Guinea, Sierra Leone, Liberia, Ghana, Nigeria, Fernando Po, Congo, Angola, Uganda, Honduras, Cuba, Jamaica, Puerto Rica, Windward Islands, Trinidad, Paraguay, Assam, Ceylon, Malaysia, Java and Australia.

A. arenosus - Sierra Leone.

A. affinis - Gulf states of America, West Indies, Matogrosso (Brazil), Paraguay, Venezuela, temperate S. America (Alemania and

Provincia de Tolxa), Singapore, Malaysia, Australia, Japan and the Pacific Islands.

Appendix 2.

Sources of materials.

<u>Origin</u>	<u>Habitat</u>	<u>Collector</u>	<u>Reference</u>
Mt.Aureol.	wet,shaded.	D.G.	101
Pepel.	dry,exposed,sandy.	D.G.	102
Mt.Aureol.	Dry,exposed.	D.G.	103
Mt.Sugarloaf.	dry,rocky summit.	D.G.	104
Bo.	wet,exposed,sandy.	D.G.	105
Monrovia,Liberia.	dry,exposed,sandy.	D.G.	106
Legon,Ghana.	dry,shaded,sandy.	D.G.	107
Togoland.	?	J.M.Klitz.	108
Ibadan,Nigeria.	?	H.T.Clifford.	109
Pujehun.	dry,shaded,sandy.	D.G.	110
Messima.	seasonally wet.	D.G.	111
Leicester.	wet,shaded.	D.G.	201
Njala.	wet,shaded.	D.G.	202
Kindia,Guinea.	wet,shaded.	?	203
Achimota,Ghana.	botanic gardens.	C.D.Adams.	204
Messima.	seasonally flooded.	D.G.	205
Mano Bonjema.	seasonally flooded.	D.G.	206
Abidjan,Ivory Coast.	'bas fond humid'.	J.Brun.	207
Gloucester.	wet,shaded.	D.G.	301
Hastings.	wet,exposed.	D.G.	302
Njala.	wet,shaded,sandy.	D.G.	303
Hamilton.	shaded,sandy,saline.	D.G.	304
Bonthe.	wet,shaded,sandy.	D.G.	305

Pujehun.	dry, shaded, sandy.	D.G.	305
Bo.	dry, shaded, sandy.	D.G.	306
Sussex.	shaded, sandy, saline.	D.G.	307
Florida, U.S.A.	Kilgore Seed Company		401
Australia	Royal Botanic Garden, Sydney.		402

Herbarium collections examined.

Royal Botanic Garden, Kew. 328 specimens of the A.compressus complex, and specimens of 54 other species in the genus.

Royal Botanic Garden, Edinburgh. 8 specimens of the A.compressus complex.

Botanische Staatssammlung, Munich. 37 specimens of the A.compressus complex.

Sierra Leone Agricultural Department, Njala. 9 specimens of the A.compressus complex.

Paris Herbarium. Type materials of Henrard's subsp. congoensis.

In addition to the Paris Herbarium type materials of subsp. congoensis, the following were examined at Kew:-

Hens' specimen 162 - part of the type collection for subsp. congoensis.

Pobéguin's specimen 1703 - also cited by Henrard for subsp. congoensis.

deSaeger's specimen 1336 - part of the type collection for Proupin's species, A.flexuosus.

Curtiss' specimen 6638, Kearney's specimen 356 and Ball's specimens 55 and 115 - cited by Chase as belonging to A.affinis.

BIBLIOGRAPHY AND SELECTED REFERENCES

- Ahmad, Sultan. 1954. Grasses and sedges of Lahor District.
Dept. Bot. Univ. Punjab, Publication 12.
- Ahmad, Sultan and Stewart, R.R. 1958. Grasses of West Pakistan, I; Panicoideae. Biol.Soc.Pakistan, Monogr.3; 1 - 151.
- Al-Aish, M. and Brown, W.V. 1958. Grass germination responses to isopropyl-phenyl carbamate and classification.
Amer. Jour. Bot. 45; 16 - 23.
- Amshoff, G.J.H. and Henrard, T.H. 1948. Axonopus in Pulle, "Flora of Surinam." vol.1; 339 - 346.
- Anderson, A.M. 1941. The germination of fresh seed of Axonopus. Proc.Ass.Offic.Seed Analysts of N. America. 33; 99 - 102.
- Araujo, A. de. 1943. Bol. Secret. Est. Negoc. Agr. Ind. & Com. Porto Alegre. Brasil. 100: 36.2f.
- Arber, A. 1934. The Gramineae; A study of bamboo, cereal and grass. Cambridge.
- Atwood, S.S. 1947. Cytogenetics and breeding of forage crops. Advances in Genetics, ed. Demerec, 1; 1 - 67.
- Aubreville, A. 1949. Contributions au paleohistoire Forêt Afrique. Paris.
- Avdulov, N.P. 1931. Karyo-systematische Untersuchung der Familie Gramineen. Bull.Appl.Bot.Gen. & Pl.Breed.Ser., suppl.44.

- Avdulov, N.P. and Titova, N. 1953. Additional chromosomes in Paspalum stoloniferum. Bosco. Bull. Appl. Bot. Gen. & Plant Breed. Ser., 2; 165 - 172.
- Bashaw, E.C. and Holt, E.C. 1958. Megasporogenesis, embryo sac development and embryogenesis in Paspalum dilatatum. Agron. Jour. 50; 753 - 756.
- Bashaw, E.C. 1962. Apomixis and sexuality in buffelgrass (Pennisetum ciliare). Crop Science. 2(5); 412 - 415.
- Bashaw, E.C. and Hoff, B.J. 1962. The effects of irradiation on apomictic dallisgrass. Crop Science. 2(6); 501 - 504.
- Beauvois, A.M.F.J.P. de. 1812. Essai d'une nouvelle agrostographie ou nouveaux genres de Graminées. Paris, tip. Fain. 12, e, 154.
- Beddows, A.R. 1937. The shape of the shoot bud prophyll in rye-grasses and broad leaved fescues. Welsh Jour. Agric. 13; 190 - 195.
- Beetle, A.A. 1955. The four subfamilies of the Gramineae. Bull. Torrey. Bot. Club. 82; 196 - 197.
- Bentham, G. 1881. Notes on Gramineae. Jour. Linn. Soc. Bot. 19; 14 - 134.
- Bentham, G. and Hooker, J.D. 1883. Genera Plantarum. iii; 1089. Reeve and Co., London.
- Bergman, B. 1941. Studies on the embryo sac mother cell and its development in Hieracium subg. Archieracium. Sv. Bot. Tidskr. 35; 1 - 42.

- Bews, J.W. 1929. The world's grasses.
London.
- Biswell, H.H., Shepherd, W.O., Southwell, B.L. and Boggess, T.S.
1943. Native forage grasses of cutover forest lands in the
coastal plain of Georgia. Georgia Coast. Plain Exp. Sta.
Bull. 37; 1 - 43.
- Black, G.A. 1950. Novas especies de Panicaceae (Gramineae) no
Brasil. Bol. Teleg. I.A.N. 4(20); 34 - 35.
- Black, G.A. 1963. Grasses of the genus Axonopus.
Adv. Front. Plant Sci. 5; 1 - 186.
- Blatter, E.J. and McCann, C. 1927-30. Revision of the flora of
the Bombay Presidency; Gramineae. Jour. Bombay Nat. Hist.
Soc. 32; 14, 281, 408, 622. 33; 7, 299, 480, 753. 34; 12.
- Bogdan, A.V. 1952. Observations on stoloniferous grasses in
Kenya. Jour. East African, Uganda Nat. Hist. Soc. 20; 71.
- Bor, N.L. 1952. Gramineae, in Wendelbo, "Plants of Tirich Mir".
Nytt Mag. Bot. 1; 16 - 20.
- Borgaonkar, D.D. 1961. Segregation among partially apomictic
Bothriochloa hybrids. Amer. Journ. Bot. 48(6); 545.
- Bosemark, N.O. 1957. Further studies on accessory chromosomes
in grasses. Hereditas, Lund. 43; 236 - 297.
- Bowden, B.N. 1962. An illustrated key to the commoner Uganda
grasses. East African Agric. and Forest Jour. 27(4);
230 - 251.

- Bowden, W.M. and Sen, H.A. 1962. Chromosome numbers in 28 grass genera from South America. Canadian Jour. Bot. 40,8; 1115 - 1124.
- Brown, R. 1814. In Mathew Flinders "A voyage to Terra Australis". London.
- Brown, W.V. 1948. A cytological study in the Gramineae. Amer. Jour. Bot. 35(7); 382 - 395.
- Brown, W.V. 1950. A cytological study of some Texan grasses. Bull. Torrey Bot. Club. 77; 63 - 76.
- Brown, W.V. and Emery, W.H.P. 1957. Apomixis in the Gramineae, tribe Andropogoneae; Themeda and Bothriochloa. Bot. Gaz. 118(4); 246 - 253.
- Brown, W.V. and Emery, W.H.P. 1957. Some South African apomictic grasses. Jour. South African Bot. 23; 123.
- Brown, W.V. and Emery, W.H.P. 1957. Extra ovular development of embryos in two grass species. Bull. Torrey Bot. Club. 84; 361 - 365.
- Brown, W.V. and Emery, W.H.P. 1957. Persistent nucleoli and grass systematics. Amer. Jour. Bot. 44(7); 585 - 590.
- Brown, W.V., Heimsch, C. and Emery, W.H.P. 1957. Organisation of the grass shoot apex and systematics. Amer. Jour. Bot. 44(7); 590 - 595.
- Brown, W.V. 1958. Leaf anatomy in grass systematics. Bot. Gaz. 119; 170 - 178.

- Brown, W.V. 1958. The epiblast and coleoptile of the grass embryo. Bull. Torrey Bot. Club. 86; 13 - 15.
- Brown, W.V. and Emery, W.H.P. 1958. Apomixis in the Gramineae; Panicoideae. Amer. Jour. Bot. 45(4); 253 - 263.
- Brown, W.V. 1960. The morphology of the grass embryo. Phytomorphology. 10(3); 215 - 223.
- Burton, G.W. 1942. Chromosome numbers of grasses. Amer. Jour. Bot. 29; 355 - 359.
- Burton, G.W. 1943. Interspecific hybrids in the genus Paspalum. Jour. Hered. 34; 14 - 23.
- Burton, G.W. 1943. Root formation in grasses. Jour. American Soc. Agron. 35(3); 192 - 196.
- Burton, G.W. 1962. Conventional breeding of dallisgrass, Paspalum dilatatum Poir. Crop Science. 2(6); 491 - 494.
- Burton, G.W. 1962. Radiation breeding of apomictic prostrate dallisgrass, Paspalum dilatatum var pauciciliatum. Crop Science. 2(6); 495 - 497.
- Carnahan, H.L. and Hill, H.D. 1961. Cytology and genetics of forage grasses. Bot. Rev. 27(1); 1 - 162.
- Celarier, H.L. and Harlan, J.R. 1957. Apomixis in Bothriochloa, Dichanthium and Capillipedium. Phytomorphology. 7; 93.
- Chandra, N. 1962. Morphological studies in the Gramineae; Vascular anatomy of the spikelets in the Paniceae. Proc. Indian Acad. Sci. B. 56; 217 - 231.

- Chase, A. 1911. Notes on genera of Panicaceae, genus Axonopus,
Beauv.. Proc. Biol. Soc. Washington. 24; 129 - 136.
- Chase, A. 1938. The carpet grasses.
Jour. Washington Acad. Sci. 28; 178 - 182.
- Cheadle, V.I. 1955. The taxonomic use of specialisation of
vessels in the metaxylem of Gramineae, Cyperaceae, Juncaceae
and Restionaceae. J. Arnold, Arbor. 36; 141 - 157.
- Chippindal, L.K.A. 1955. In Meredith, D.B.D. The grasses and
pastures of South Africa. Central News Agency, Johannesburg.
- Cleland, R.E. 1951. Extra diminutive chromosomes in Oenothera.
Evolution. 5; 142 - 157.
- Clark Row, H. and Reeder, J.R. 1957. Root hair development as
evidence of relationship among genera of Gramineae.
Amer. Jour. Bot. 44; 596 - 601.
- Clausen, J. 1961. Introgression facilitated by apomixis in
polyploid Poas. Euphytica 10; 87 - 94.
- Clausen, J., Keck, D.D. and Hiesey, W.M. 1945. Experimental
studies on the nature of species.
Carnegie Inst. Washington. Publ. 564.
- Clausen, J. 1954. Partial apomixis as an equilibrium system
in evolution. Caryologia. 6; 469 - 479.
- Cross, D.O. 1938. Narrow leaved carpet grass and a broad leaved
form. Agric. Gaz. New South Wales. 49; 647.

- Cugnac, A. de. 1931. Les glucides des Graminées.
Ann. Sci. Nat. Bot. ser.10, 13; 1 - 129.
- Darlington, C.D. 1963. Chromosome Botany. ed.2.
Allen and Unwin, London.
- Dedecca, D.M. 1956. As especies Brasileiras do genero Axonopus,
Gramineae. Bragantia. 15; 251 - 956.
- Deighton, F.C. 1957. Vernacular Botanical Vocabulary for Sierra
Leone. Crown Agents, London.
- Delay, C. 1950. Nombres chromosomique chez les Phanerogammes.
Rev. Cyt. et Biol. Vag. 12; 1 - 368.
- Deshpande, B.D. and Sarkar, S. 1962. Nodal anatomy and the
vascular system of some members of the Gramineae.
Proc. Nat. Acad. Sci. India. B. 28(1); 1 - 12.
- DeWet, J.M.J. 1956. Leaf anatomy and phylogeny in the tribe
Danthoneae. Amer. Jour. Bot. 43; 175 - 182.
- DeWet, J.M.J. and Anderson. 1956. Chromosome numbers in Trans-
vaal grasses. Cytologia. 21; 1 - 10.
- Emecz, T.I. 1961. Meteorological factors and anthesis in
grasses. Rep. Welsh Pl. Breed. Inst. Aberystwyth. 125 - 126.
- Emecz, T.I. 1962. The effect of meteorological conditions on
anthesis in agricultural grasses. Ann. Bot. 26(102);
159 - 172.
- Duval-Jouve, M.J. 1875. Histotaxie des feuilles des Graminées.
Ann. Sci. Nat. Bot. ser.6. 1; 294 - 371.

- Emery, W.H.P. 1957. A study of reproduction in Setaria macrostachya and its relatives in S.W. United States and New Mexico. Bull. Torrey Bot. Club. 84; 106.
- Farquharson, L.I. 1955. Apomixis and polyembryony in Tripsacum dactyloides. Amer. Jour. Bot. 42; 737 - 743.
- Fischer, C.E.C. 1934. Flora of Madras. Gramineae. 10; 1689 - 1864.
- Fisher, W.D., Bashaw, E.L. and Holt, E.C. 1954. Evidence for apomixis in Pennisetum ciliare and Cenchrus setigerus. Agron. Jour. 46; 401 - 404.
- Fryxell, P.A. 1957. The mode of reproduction of higher plants. Bot. Rev. 23; 135.
- Gandhi, S.M., Bhargava, P.D. and Bhatnagar, M.P. 1961. Grasses of Jaipur. Proc. Nat. Acad. Sci. India, B. 31(2); 183 - 192.
- Gildenhuis, P. and Brix, K. 1958. Somatic instability, abnormal meiosis and apomixis in a Pennisetum sp. Proc. 1st Cong. S.African Gen. Soc. 7; 55 - 56.
- Gledhill, D. 1962. Biosystematic studies of the Axonopus compressus complex; A new subspecies from West Africa. Phytomorphology. 12(4); 412 - 418.
- Gould, F.W. 1956. Chromosome counts and cytotaxonomic notes on grasses of the tribe Andropogoneae. Amer. Jour. Bot. 43; 395 - 404.

- Gould, F.W. 1961. The grass vegetation of Texas.
Texas Agric. Progr. 7(2); 12.
- Grob, A. 1896. Beiträge zur Anatomie der Epidermis der
Gramineenblätter. Bibliotheca Botanica. 36; 1 - 100.
- Gustafsson, A. 1946. Apomixis in higher plants.
Lunds Universitetets, Årsskrift. N.F.Afd. 1 - 370.
- Hackel, E. 1881. Untersuchungen über die Lodiculae der Gräser.
Bot. Jahrb. 1; 336 - 361.
- Hackel, E. 1887. Gramineae. In Engler and Prantl "Die ~~Natur-~~
~~lich Pflanzenfamilien~~" 2(2); 35. Wilhelm Engelmann, Leipzig.
- Hair, J.B. 1952. Subsexual reproduction in Agropyron.
Heredity Suppl. 6; 215 - 233.
- Hair, J.B. 1956. The origin of new chromosomes in Agropyron.
Heredity 10; 129 - 160.
- Håkanson, A. 1954. The transmission of accessory chromosomes
in Poa alpina. Hereditas. 40; 523 - 526.
- Hansen, I. and Potztal, E. 1953. Beiträge zur Anatomie und
Systematik der Leptureae. Bot. Jahrb. 76; 251 - 270.
- Hartley, W. 1950. The global distribution of tribes of the
Gramineae in relation to the historical and environmental
factors. Australian Jour. Agric. Res. 1; 355 - 373.
- Hartley, W. 1958. Studies on the origin, evolution and dis-
tribution of the Gramineae. Andropogoneae.
Australian Jour. Bot. 6; 116 - 128.

- Hayman, D.L. 1956. Cytological evidence for apomixis in Australian Paspalum dilatatum. Jour. Australian Inst. Agric. Sci. 22; 292.
- Heinz, D.J. 1962. Improvement of grasses through induced chromosomal recombinations. Dissert.Abstracts. 22(12); 4149.
- Henrard, J.Th. 1941. Notes on the nomenclature of some grasses. Blumea 5; 496 - 538.
- Henrard, J.Th. 1942. A new species of Axonopus. Blumea 5; 274 - 279.
- Henrard, J.Th. 1945. A new subspecies of Axonopus compressus. Blumea 5; 529.
- Hitchcock, A.S. 1922. The grasses of British Guiana. Contrib. U.S. Nat. Herb. 22; 470 - 474.
- Hitchcock, A.S. 1927. The grasses of Equador, Peru and Bolivia. Contrib. U.S. Nat. Herb. 24; 430 - 434.
- Hitchcock, A.S. 1930. The grasses of Central America. Contrib. U.S. Nat. Herb. 27; 626 - 629.
- Hitchcock, A.S. 1935. The grasses of the Central Andes. Contrib. U.S. Nat. Herb. 30; 431.
- Hitchcock, A.S. 1936. The grasses of the West Indies. U.S. Dept. Agrig. Misc. Publ. 243. 187 - 191.
- Hitchcock, A.S. 1951. Manual of the grasses of the United States. U.S. Dept. Agric. Misc. Publ. 200; ed.2. 595 - 596.

- Holttum, R.E. 1956. The classification of Bamboos.
Phytomorphology. 6; 73 - 90.
- Hooker, J.D. 1896. Flora of British India.
7; 64. W. Pamplin, London.
- Howell, J.T. 1956. Axonopus compressus (Sw.) Beauv.; A lawn
weed in S. California. Leaflets of Western Botany 8(1); 23.
- Hubbard, C.E. 1934. Gramineae. In Hutchinson, J. "Families
of flowering plants" 2; 199 - 229.
- Hubbard, C.E. and Vaughan, R.E. 1940. Grasses of Mauritius and
Rodrigues. 85 - 86. London.
- Hubbard, C.E. 1948. Gramineae. In Hutchinson, J. "British
flowering plants" 284 - 348. London.
- Hutchinson, J. and Dalziel, J.M. 1936. Flora of West Tropical
Africa. Crown Agents, London.
- International Code of Botanical Nomenclature. 1961.
- Jacobsen, P. 1954. Technique for studying structure of root
tip chromosomes. Hereditas 40; 252.
- Jago, R.B. 1940. Carpet grass; Axonopus spp.
Garden Bull. Straits Settlement of Singapore. 11; 109 - 118.
- Jago, R.B. 1941. Species of carpet grass.
Malayan Agric. Jour. 29; 50.
- Janaki-Amal, E.K. 1955. In Darlington, C.D. and Wylie, A.P.
Chromosome atlas of flowering plants. Allen and Unwin,
London.

- Jaques-Felix, H. 1955. La systematique des Graminées de Pilger.
Jour. d'Agric. Trop. Bot. Appl. 2; 207 - 211.
- Jaques-Felix, H. 1958. Sur une interpretation nouvelle de
l'embryon des Graminées. C.R. Acad. Sci. Paris. 146;
1950, 150 - 153.
- Jaques-Felix, H. 1959. Les Graminées de Afrique Tropicale dans
la classification. 9th Cong. Internat. Bot. 2; 178 - 179.
- Jenkin, T.J. 1924. In Welsh Plant Breeding Bull. ser.H. no.2.
- Jisaburo, O. 1942. Key to Japanese species of Axonopus.
Acta Phytotax. and Geobot. 11; 27 - 56.
- Jones, K. 1963. The cytology of Anthoxanthum.
Proc. Linn. Soc. London. 173(2); 109 - 111.
- Jordan, H.D. 1957. Hybridisation of Rice.
Tropical Agric. 34; 133 - 136.
- Julen, G. 1960. The effect of X-rays on apomixis in Poa pratensis.
In "The effects of ionising radiations on seeds".
Int. Atom. Energy Agency, Vienna. 527.
- Karpechenko, G.D. 1927. Polyploid hybrids of Raphanus sativus
x Brassica oleracea. Bull. Appl. Bot. Genet. Plant Breed.
17; 305 - 410.
- Knox, R.B. and Heslop-Harrison, J. 1963. Experimental control
of aposporous apomixis in a grass of the Andropogoneae.
Bot. Not. 116; 1; 127 - 141.
- Koechlin, Jc 1961. Graminées nouvelle du Gabon.
Bull. Soc. Bot. France. 108(56); 243 - 244.

- Krishnaswamy, N. 1940. Untersuchungen zur Cytologie und Systematik der Gramineen. Beih. Bot. Centralbl. 60; 1 - 56.
- Kuhlmann, J.G. 1948. Gramineas do Rio de Janeiro.
Comm. Lin. Telegr. Matto Grosso Amaz. 5 bot.11; 87.
- Kuhlmann, J.G. 1948. Axonopus in Brasil.
Comm. Lin. Telegr. Matto Grosso Amaz. 5 bot.11; 52.
- La Cour, L. 1941. Acetic-orcein.
Stain Technol. 18; 169 - 174.
- Lambourne, J. 1924. A preliminary report on carpet grass.
Malayan Agric. Jour. 12;
- Levan, A. 1935. Zytologische Studien an Allium schoenoprasum.
Diss. Lund. (also in Hereditas 22; 1 - 128.)
- Lewis, H. 1951. The origin of supernumerary chromosomes in populations of Clarkia elegans. Evolution 5; 142 - 157.
- Lewis, H. 1953. Quantitative variation in wild genotypes of Clarkia. I.U.B.S. Symposium Genet. Popul. Struct. 114 - 125.
- Lohaus, K. 1905. Der anatomische Bau der Laubblätter der Festucaceen. Bibliotheca Botanica. 63; 1 - 110.
- Lundquist, A. 1961. A rapid method for analysis of incompatibility in grasses. Hereditas. 47(3/4); 705 - 707.
- MacLeod, A.M. and McCorquodale, H. 1958. Water soluble carbohydrates in seeds of Gramineae. New Phyt. 57; 168 - 182.
- Maheshwari, P. 1950. An introduction to the embryology of angiosperms. New York and London.

- Massey, A.B. 1958. Grasses in Virginia.
Virginia Jour. Sci. 9(4); 396.
- Matuda, E. 1958. Las Gramineas del estado De Mexico.
Com. Bot. Expl., Trab. 22; 3 - 83.
- McLennan, L.W. 1936. Carpet grass; has it a place in North
Coast Pastures? Agric. Gaz. N.S. Wales. 49; 555 - 558,
601 - 604.
- Melander, Y. 1950. Accessory chromosomes in animals, especially
Polycelis tenuis. Hereditas, Lund. 36; 19 - 38.
- Menon, T.C.K. 1956. The essential oil of Cymbopogon travan-
corensis Bor. Jour. Bombay Nat. Hist. Soc. 53; 742.
- Metcalf, C.R. 1960. Anatomy of the monocotyledons; Gramineae.
Oxford University Press, London.
- Milinkovic, V. 1957. Accessory chromosomes in root of Poa
alpina. Hereditas, Lund. 43; 583 - 588.
- Milsum, J.N. 1924. Fodder and grazing grasses in Malaya.
Malayan Agric. Jour. 12;
- Mochizuki, A. 1957. B-chromosomes in Aegilops mutica.
Wheat Inf. Ser., Kyoto. 5; 9 - 11.
- Müntzing, A. 1948. Accessory chromosomes in Poa alpina.
Heredity. 2; 49.
- Myers, W.M. 1947. Cytology and genetics of forage grasses.
Bot. Rev. 13; 318.

- Narayan, K.N. 1955. Cytogenetic studies of apomixis in Pennisetum. Proc. Indian Acad. Sci. B. 41; 196.
- Nees ab Esenbeck, C.G. 1938. Agrostologia Brasiliensis. 18 - 83. J.G. Cottae, Stuttgart.
- Nielson, E.L. 1959. Meiotic behaviour in putative Agroelymus hybrid. Agron. Abst. 63;
- Nigerian Grass Yearbook, 1948. Lagos, Nigeria.
- Nuñez, O. 1946. In Parodi, L.R. "Clava para la determinacion de los generos y enumeracion de las especies Gramineas Bonariensis" ed.4. Buenos Aires.
- Nygren, A. 1951. Form and biotype formation in Calamagrostis purpurea. Hereditas, Lund. 37; 519 - 532.
- Nygren, A. 1954. Apomixis in angiosperms. Bot. Rev. 23; 135.
- Nygren, A. 1958. Poa timoliensis; A new diploid with accessory chromosomes. Lantbrukshogskolans Annlar. 23; 487 - 495.
- Parodi, L.R. 1938. Gramineas Austroamericanas nuevas o criticas. Not. Mus. La Plata. 3(Bot, 17); 15 - 33.
- Parodi, L.R. 1939. Gramineas Bonariensis; Clava para la determinacion de los generos etc., ed.3. 98. Buenos Aires.
- Parodi, L.R. 1959. Classificacion de las Gramineas Argentinas basada en la morfologia la cariologia y la anatomia foliar. 9th Int. Bot. Cong. 2; 295.

- Parodi, L.R. 1961. Gramineas Argentinas nuevas o criticas;
Axonopus paranaensis. Rev. Argentina Agron. 28; 100 - 125.
- Parry, D.W. and Smithson, F. 1958. Technique for studying the
opaline silica cells in grasses. Ann. Bot. 22; 88.
- Parthasarathy, N. 1946. The probable origin of North Indian
sugarcanes. Jour. Indian Bot. Soc. Iyengar Comm. Vol.
133 - 150.
- Patil, B.D., Vohra, S.K. and Joshi, A.B. 1961. Chromosomes
numbers in some forage grasses. Current Sci. 30(10);
393 - 394.
- Peacock, H.A. 1950. Elementary microtechnique.
Edward Arnold & Co., London.
- Pee-Laby, E. 1899. Etude anatomique de la feuille des Graminées
de la France. Ann. Sci. Nat. Bot. 8; 227 - 346.
- Peevy, F.A. 1953. Axonopus affinis pasture.
Agron. Jour. 45(4); 164 - 166.
- Peter, A. 1930. Flora von Deutsche Ostafrika.
Fedde Rep. 40(1); 165 and Anhang 60.
- Pilger, R. 1954. Das System der Gramineen.
Bot. Jahrb. 76; 281 - 384.
- Piper, C.V. and Carrier, L. 1920. Carpet grass.
U.S. Dept. Agric. Bull. 1130.
- Potztal, E. 1956. Nachtrag zu Gramineae. In Engler and Prantl
"Die Nat. Pfl." 14d; 171. Band 14e. Wilhelm Engelmann,
Leipzig.

- Powers, L. 1944. Fertilisation without reduction in Parthenium argentatum. Genetics. 30; 322 - 346.
- Raizda, M.B., Bharadwaja, R.C., and Jain, S.K. 1961. Grasses of the upper Gangetic Plain. Panicoideae. Indian Forest Rec. Bot. 4(7); 171 - 277.
- Rattray, J.M. 1960. The grass cover of Africa. Food. and Agric. Org. United Nations. 49; 1 - 168.
- Reeder, J.R. and von Maltzahn, K. 1953. Taxonomic significance of root hair development in the Gramineae. Proc. Nat. Acad. Sci. U.S. 39; 593 - 598.
- Reeder, J.R. 1957. The embryo in grass systematics. American Jour. Bot. 44; 756 - 768.
- Reese, G. 1954. Euploidie, aneuploidie und B-chromosomen bei Caltha palustris. Planta. 44; 203 - 268.
- Riley, H.P. 1957. Introduction to genetics and Cytogenetics. John Wiley & Sons, New York.
- Riley, R. 1960. The diploidisation of polyploid wheat. Heredity 15; 407 - 429.
- Runemark, H. 1961. The species and subspecies concept in sexual flowering plants. Bot. Not. 114(1); 22 - 32.
- Roseveare, G.M. 1948. The grasslands of Latin America. Imp. Bur. Pastures and Field Crops Bull. 36. London.
- Sears, C.R. and Okamoto, M. 1957. Intergenomic relationships in hexaploid wheats. Proc. 10th Int. Cong. Gen. 2; 258 - 259.

- Sheth, A.A., Yu, L. and Edwardson, J. 1956. Sterility in pangolagrass; Digitaria decumbens, Stent. Agron. Jour. 48; 505 - 507.
- Sinnott, E.W. and Bloch, R. 1939. Cell polarity and differentiation of root hairs. Proc. Nat. Acad. Sci. 25; 248 - 252.
- Skalinska, M. 1959. Embryological studies in Poa granitica, an apomict of the Carpathian Range. Acta Biologica Cracoviensia Bot. 2; 91 - 115.
- Snyder, L.A. 1957. Apomixis in Paspalum secans. American Jour. Bot. 44; 318.
- Snyder, L.A., Hernandez, A.R. and Warmke, H.E. 1955. The mechanism of apomixis in Pennisetum ciliare, L., Link. Bot. Gaz. 116; 209 - 221.
- Snyder, L.A. 1961. Asyndesis and meiotic nondisjunction in microsporogenesis of apomictic Paspalum secans. Cytologia. 21(1); 50 - 61.
- Sokolovskaya, A.P. and Strelkova, O.S. 1938. Polyploidy in the high mountain regions of Pamir and Altai. C.R. Acad. Sci. USSR. 21; 68 - 71.
- Stapf, O. 1919. In Prain, "Flora of Tropical Africa". 9; 1 - 768. L. Reeve & Co., London.
- Stebbins, G.L. 1949. Asexual reproduction in relation to plant evolution. Evolution. 3; 98 - 101.

- Stebbins, G.L. 1956. Taxonomy and evolution of genera, with special reference to the family Gramineae.
Evolution. 10; 235 - 245.
- Stebbins, G.L. 1956. Cytogenetics and evolution in the grasses.
American Jour. Bot. 43; 890 - 905.
- Streetman, L.J. and Wright, N. 1960. Cytological study of Bouteloua eriopoda. Amer. Jour. Bot. 47; 786 - 793.
- Surkov, V.A. 1961. Ontogenez i morfologicheskaya priroda chlenov tsvetka u zlakov. (parts of the grass flower)
Bot. Zhur. 46(8); 1134 - 1143.
- Swallen, J.R. 1933. New grasses from the United States, Mexico and Central America. Jour. Washington Acad. Sci. 23; 456 - 460.
- Swallen, J.R. 1943. Flora of Panama, part 2, Gramineae.
Ann. Missouri Bot. Gard. 30; 104 - 280.
- Swallen, J.R. 1948. Axonopus from Guiana.
Bull. Torrey Bot. Club. 75; 82 - 84.
- Swallen, J.R. and Hernandez, E. 1961. Clava de los generis Mexicanos de gramineas. Bol. Soc, Bot. Mexico. 26; 52 - 118.
- Swartz, O. 1788. Nova genera et species plantarum seu Prodrromus etc.,. 24. M. Swederi, Upsala.
- Swartz, O. 1797. Milium compressum.
Flora India occidentale. 1; 183 - 184. Benj. White and Sons, London.

- Tateoka, T. 1954. Systematic significance of starch grains in Poaceae. Jour. Japanese Bot. 29; 341 - 347.
- Tateoka, T. 1956. Re-examination of the anatomical characteristics of the leaves in Eragrostoideae and Panicoideae (Poaceae). Jour. Japanese Bot. 31; 210.
- Tateoka, J. 1957. Proposition for a new phylogenetic system for Poaceae. Jour. Japanese Bot. 32; 275 - 287.
- Tateoka, J. 1962. A cytological study of some Mexican grasses. Bull. Torrey Bot. Club. 89(2); 77 - 82.
- Thomas, P.T. 1940. Reproductive versatility in Rubus. Jour. Genet. 40; 119 - 128 and 141 - 156.
- Thomas, P.T. 1961. Chromosomes and grass breeding. Jour. British Grassland Soc. 16(4); 276 - 277.
- Troupin, G. 1956. Flore des spermatophytes du Parc National de la Garamba. Exploration du Parc National de la Garamba, 1 fasc. 4; 18 - 19.
- Townrow, J.E.S. 1960. Some grasses of South Western Nigeria. Ibadan University Press, Nigeria.
- Vaarma, A. 1953. Chromosome fragmentation and accessory chromosomes in Orthotrichum tenellum. Hereditas, Lund. 39; 305 - 316.
- Valentine, D.H. and Heywood, V.H. 1961. An approach to the taxonomic treatment of polyploidy and apomixis in Flora Europea. Recent Adv. Bot. 9; 944 - 947.

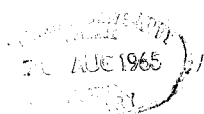

- Virkkii, N. 1954. Akzessorische chromosomen bei zwei Käfern
Epicometis hirta und Oryctes nasicornis.
Ann. Acad. Sci. Fenn ser.A.4. Biol. 26; 1 - 19.
- Walters, S.M. 1959. Suggested treatment for Alchemilla in Flora
Europaea. Proc. Fl. Europ. Conf. Vienna.
- Warmke, H.E. 1954. Apomixis in Panicum maximum.
American Jour. Bot. 41; 5 - 11.
- Weatherwax, P. 1961. Correlations between fruit coverings and
embryo structure in some Gramineae. Amer.Jour.Bot. 48(6);
537.
- White, C. 1935. Broad leaved carpet grass.
Queensland Agric. Jour. 43; 503.
- White, C. 1935. Carpet grass.
Queensland Agric. Jour. 44; 117.