

Durham E-Theses

The application of mathematical programming to educational planning

Georgoulas, Constantin

How to cite:

Georgoulas, Constantin (1976) *The application of mathematical programming to educational planning*, Durham theses, Durham University. Available at Durham E-Theses Online:
<http://etheses.dur.ac.uk/9161/>

Use policy

The full-text may be used and/or reproduced, and given to third parties in any format or medium, without prior permission or charge, for personal research or study, educational, or not-for-profit purposes provided that:

- a full bibliographic reference is made to the original source
- a [link](#) is made to the metadata record in Durham E-Theses
- the full-text is not changed in any way

The full-text must not be sold in any format or medium without the formal permission of the copyright holders.

Please consult the [full Durham E-Theses policy](#) for further details.

THE APPLICATION OF MATHEMATICAL PROGRAMMING
TO EDUCATIONAL PLANNING

by

CONSTANTIN GEORGOULAS

being a Thesis submitted to the Faculty of Science,
University of Durham for the fulfilment of the M.Sc. degree

DURHAM, ENGLAND
November, 1976

To my parents

ACKNOWLEDGEMENT

I am grateful to my supervisor Dr. D.M. Greig for her continuous help, advice and encouragement throughout this work. Thanks are also due to Mr. M.A. Abd-El-Naby for valuable comments and discussion.

ABSTRACT

In the present study a review is given of recent work on educational planning problems using mathematical programming. Furthermore a mathematical model based on data from the British educational system and utilising the technique of Dynamic programming has been developed and it is shown how the computer results from this could be used as an aid in decision making.

CONTENTS

	Page
ACKNOWLEDGEMENTS	
ABSTRACT	
CHAPTER I: EDUCATIONAL PLANNING	1
1.1 Definition of educational planning	1
1.2 Objectives and scope of educational planning	1
1.3 Characteristics of contemporary educational planning	3
1.4 Approaches to educational planning	3
1.4.1 The Manpower requirements approach	4
A. Some methodological aspects of the Manpower requirements approach	5
B. Critique of the Manpower requirements approach	8
1.4.2 The Social demand approach	10
A. Some methodological aspects of the Social demand approach	11
B. Critique of the Social demand approach	14
1.4.3 The Cost-Benefit approach	15
A. Some methodological aspects of the Cost-Benefit approach	16
B. Critique of the Cost-Benefit approach	17
1.4.4 Other approaches to educational planning	19
CHAPTER II: MATHEMATICAL PROGRAMMING AND EDUCATIONAL PLANNING	21
2.1 The mathematical programming problem and related techniques	21
2.1.1 Linear programming	22
2.1.2 Integer programming	26
2.1.3 Goal programming	27
2.1.4 Nonlinear programming	29
2.2 Mathematical programming models in educational planning	29
2.2.1 Programming models at national level	29
2.2.2 Programming models at the regional level	35
(a) School desegregation and busing	35
(b) Optimal school location	43
(c) Financing local schools and salary scheduling	43
(d) Vocational training and establishing posts at schools	45

	Page
2.2.3 Mathematical programming models at the institutional level	48
(a) Allocating available resources in a University	49
(b) Assigning faculty to courses	56
(c) Classroom allocation	58
(d) Timetabling	61
(e) Planning curriculum - Test construction and servicing	61
2.3 A note on the contribution of Operational research to educational planning	64
 CHAPTER III: A DYNAMIC PROGRAMMING MODEL	 65
3.1 Outline of the educational system	65
3.2 Introductory concepts of Dynamic programming	67
3.2.1 Basic characteristics of Dynamic programming problems	68
3.2.2 Deterministic-Probabilistic Dynamic programming problems	70
A. Deterministic Dynamic programming	70
B. Probabilistic Dynamic programming	71
3.3 Decision making through the educational system	72
3.3.1 The statement of the problem	72
3.3.2 Formulation of the problem - terminology	73
3.3.3 Recurrence relationship	77
3.4 Numerical application	79
3.4.1 Grouping the transitions	79
3.4.2 Upper-lower subjective probabilities	79
3.4.3 Output of computer program	82
3.4.4 How the optimal path is obtained	84
3.5 Summary and analysis of the results	84
3.5.1 Second best	86
3.5.2 Possible extensions of the model	88
3.6 Conclusions	88
 APPENDIX A	
 APPENDIX B	
 APPENDIX C	
 BIBLIOGRAPHY	

CHAPTER I

EDUCATIONAL PLANNING

This chapter begins with a discussion of the concept of educational planning, its objectives and its scope. Then follows an outline of the main contemporary approaches to educational planning, namely, the Manpower requirements approach, the Social demand approach and the Cost-Benefit approach. Finally, their methodologies are presented together with some problems concerning their applications.

1.1 Definition of educational planning

There have been numerous attempts to define educational planning and to specify its essential elements. ANDERSON and BOWMAN (1967) suggested that educational planning is a process of preparing a set of decisions for future actions relating to the educational sector.

Perhaps the most general definition is that given by UNESCO (1970), defining educational planning as being the application of rational, systematic analysis to the process of educational development with the aim of making education more effective and efficient in responding to the needs and goals of students and society.

This raises the crucial question of the objectives of educational planning.

1.2 Objectives and scope of educational planning

To fix the objectives is the first step in planning and no further progress can be made before doing that. Experience reveals

that this might not be easy, since education effects almost every human activity and in a society opinions differ widely as to the relative importance of each ultimate aim involved.

The traditional educational aims have been for a long time of a social and patriotic nature. Some 2,500 years ago Spartans in ancient Greece planned their education to fit their well defined military and social objectives. Plato in his "Republic" proposed an educational scheme to serve the leadership and political needs of Athens. John Knox, in the mid-16th century described a national educational system to offer the Scots spiritual and material well being. Even today we can find in official declarations and national constitutions these traditional aims.

At a second stage emphasis was laid on intellectual training primarily literacy and general knowledge. One of the earliest attempts to employ educational planning was the first Five year plan in the Soviet Union in 1923. In the industrialised countries of Europe prior to the Second World War, the essential aim was to provide continuity and viability of educational establishments and thus the focus of planning was on the mechanics of education, on the needs of the system.

But the picture changed after the Second World War. Two new dimensions were added to educational planning. First, the explosive increase of student numbers partly because of demographic factors and partly by the democratisation of educational opportunity. Second, a change in the attitude of economists as far as education was concerned. No longer was education seen merely as a non-productive sector which absorbed "consumption expenditure", it was now viewed as an essential "investment expenditure" for economic growth. If educational systems were to serve their students and society, the whole idea of planning must now be seen with new perspective, (COOMBS, 1970).

1.3 Characteristics of contemporary educational planning

Before describing in detail the contemporary approaches to educational planning which have emerged from worldwide discussions and research, some general points may be made.

The educational system in any country in producing trained manpower has a long production cycle and the successive stages of the educational process are intimately connected. Any planning has therefore to be long run and comprehensive.

Economic development implies rapid and profound changes in the methods and techniques of production. Since one of the functions of any educational system is to provide society's labor force with the skills and knowledge required for productive activities, it follows that the educational system must be reasonably geared to the production requirements. Furthermore, General education for the population in the non-industrialised countries particularly can contribute to the industrialisation by making people aware of Science and Technology; but it can also be a powerful weapon for social and political change. However skills may be rendered unusable by the social and economic change in the outside world with the problems of "job opportunities" and the so-called "educated unemployment".

Given that one of the essential tasks in planning is to determine the objectives and establish priorities among them some of which may be qualitative (cultural, ethical, etc.), educational planning need not be confined to quantitative aspects only.

1.4 Approaches to educational planning

The classification scheme used here is from "The World Year Book of Education 1967 : Educational Planning" (1967), namely, the

Manpower requirements approach, the Social demand approach, and the Cost-Benefit approach. Each of them in turn will be discussed attempting to analyse their strengths and weaknesses.

1.4.1 The Manpower requirements approach

The rationale behind this approach is the idea that the output of the educational system should be determined by a quantitative forecast of the requirements for educated manpower necessary to support the pace of the economic development in a country. Therefore acceptance of the Manpower approach as a basis for planning depends on this particular view of the function of the educational system in a modern society. This approach requires

- (1) The assumption that there is no such mechanism analogous to the market which is provided by the Perfect Competition theory, that will control automatically and efficiently the supply and demand needs of the educational system. In fact the advocates of the Manpower approach go a step further claiming that even if such a mechanism does exist it operates too slowly to ensure allocation of the educational resources according to national needs. As a result no country has based its educational planning entirely on a market mechanism.
- (2) The assumption that the labor force can be subdivided into groups of persons performing different sets of functions which demand various skills and knowledge.
- (3) The assumption that these requirements can be acquired through the process of the educational system.
- (4) The assumption that there is an occupational-educational correspondence which provides the basis for determining the "outputs" during the planning period from the several levels of the educational system. These "output" estimates permit the calculation of required enrolments, teachers, plants and equipments.

(5) The assumption that there is a fixed relationship between productivity levels and occupational structure on the one hand and between occupation and educational qualification on the other.

(6) The assumption that there is or at least should be a distinction between projections and forecasts as they are used in the Manpower requirements approach. PARNES (1964) explained that the projections indicate what will happen if the education system remains undisturbed. Forecasts indicate what the educational needs should be in the target year if a certain economic growth rate is to be realised. In other words forecasts are conditional predictions and for the purposes of educational planning do not need to be detailed.

(7) The assumption that although the maintenance of the economic system is the main function, other functions which education serves are not excluded. On the contrary a large place is given to social and cultural objectives which underlie the educational needs. Manpower criteria provide a first estimate of the minimum educational needs. To these, requirements derived from other objectives can be added. For a full treatment of the Manpower requirements approach see PARNES (1962).

A. Some methodological aspects of the Manpower requirements approach

There is no single generally accepted method of making Manpower forecasts. BLAUG (1970) summarised the methods as:

- (a) The employer's opinion method.
- (b) The incremental labor-output ratio method.
- (c) The density ratio method.
- (d) The Parnes-MRP method.

At this point a description of the methodology used in the Mediterranean Regional Project (M.R.P.) will be presented. M.R.P. was

a major operational activity undertaken by the "Organization for Economic Cooperation and Development" (O.E.C.D.) together with six of its member countries to apply a common methodology in formulating their educational plans. It represents one of the most significant efforts in educational planning to move from theory to reality and to prove that it is possible to base educational plans on Manpower forecasts. Full presentation of the M.R.P. is given in HOLLISTER (1966). Briefly the sequence of steps is as follows:

Step 1: Since the logic of the Manpower approach is to link the targets of the economic system with those of the economic one, estimates of the total output of the economy during the planning period are exogenously provided by the economic plan in the form of Gross National Product (G.N.P.).

Step 2: The total output is subdivided into sectoral output, such as agriculture, manufacturing, etc.

Step 3: Estimates of the average labor-output coefficient, which is the inverse of the sectoral productivity, are taken. The average labor output coefficient represents the number of persons employed per unit of sectoral output. Multiplying these estimates by those in step 2 the resultant is an estimate of the number of workers required in each sector.

Step 4: Estimates of the sectoral occupational distribution are taken. Multiplying these estimates by the estimates of step 3, we get the number of workers required in each occupation, in each sector.

Step 5: Estimates of the total occupational distribution are derived, by adding up the numbers in a given occupation for all sectors.

Step 6: Estimates of the education associated with occupation.

Multiplying these estimates with the estimates representing the numbers

of workers in a given occupation, gives the numbers of people with each kind of education in each occupation.

Step 7: Estimates of the total education stock. The estimates derived in step 6 are added up over all occupations for each educational level. The resultant are estimates of the required stock of the number of workers in the labor force having each type of education in the target year. (= target year educational stock.)

Step 8: Estimates of the increment of manpower by education. The estimates of step 7 represent the educational stock needed in the target year if a predetermined growth path is to be achieved. By subtracting from these estimates those who are already in the labor force and who are expected to survive until the target year, we get the increment of manpower by education category which will be necessary to be added to the labor force.

Step 9: Estimates of the total output flow. Since only a portion of the graduates of the educational system enter the labor force estimates of step 8 must be multiplied by estimates of the inverse of labor force participation rates of such graduates. The resultant figures represent the final estimates of the required total flow of graduates over the planning period.

The estimation of the occupational distribution of the labor force plays a central role in the methodology discussed above. From step 1 - 4 the number of workers in any occupation is determined by the four factors:

(a) the number in the occupation j , at sector i as a percentage of the employed labor force in this sector,

$$\text{i.e. } \left\{ \frac{L_{ij}}{L_i} \right\}$$

(b) the number of workers per unit of output in the sector

$$\text{i.e. } \left\{ \frac{L_i}{(\text{GNP})_i} \right\}$$

(c) the percentage distribution of GNP among sectors

$$\text{i.e. } \left\{ \frac{(\text{GNP})_i}{\text{GNP}} \right\}$$

(d) the level of GNP .

$$\text{Thus: } L_{ij} = \left\{ \frac{L_{ij}}{L_i} \right\} \left\{ \frac{L_i}{(\text{GNP})_i} \right\} \left\{ \frac{(\text{GNP})_i}{\text{GNP}} \right\} \left\{ \text{GNP} \right\}$$

If for any year these factors are multiplied together for each sector and then summed over all sectors i the resultant will be the required number of workers in that particular occupation in that particular year. The estimated change in the number of workers in the occupation over the period of the plan can be attributed to the estimated change in these four factors. The educational requirements are now calculated as from step 6.

B. Critique of the Manpower requirements approach

While the broad logic of this approach is hard to argue with the practical applications raised a number of problems. Some of the most important issues will be discussed below:

(a) The occupation-education problem

The weakest link in this approach is the lack of enough knowledge about the exact relationships concerning the occupational educational estimates. As a result these estimates are based on various assumptions about their nature.

Analysis in the M.R.P. showed that the final estimates for educational requirements were very sensitive under the assumptions made. If Manpower planning is to be used for educational purposes an "objective

means" should be found to translate the occupational estimates into the educational equivalents. But both advocates and critics of this approach agree that very little is known about this critical relationship between particular occupations and amount of education they require.

(b) The substitution problem

This question concerns whether the occupational input coefficients (i.e. the number of workers in a certain occupation per unit of output) at a given point of time are fixed or variable. Requirements estimated on the assumption of fixed coefficients may be erroneously high, because they ignore the possibility that various inputs may be substituted by others.

The results of M.R.P. suggest that substitution possibilities exist at a given point of time indicating that a range of alternative manpower requirements could be available, all compatible with a given economic target. As it was noted in HOLLISTER (1966, p.73) "*. . . the evidence of substitution possibilities can be viewed as indicative and not as conclusive. It follows that more basic research, using better data and more sophisticated techniques is required in order to establish on a more scientific basis the existence and range of substitution possibilities.*".

(c) The impact of the Manpower requirements on the educational system

Educational requirements as derived in the M.R.P. are composed of three main elements:

- (1) The education required to keep pace with the growth of the labor force as a whole.
- (2) The education required to allow the necessary adjustments in the occupational distribution of that labor force.
- (3) The education required because of changes in the kind of education associated with each occupation (i.e. the occupation-education relationship).

An argument developed on these issues questioning the significance of the contribution of factors (2) and (3) to the educational needs, on the grounds that the educational systems will grow roughly in accordance with the economy and the labor force and therefore elaborate calculations of factors (2) and (3) are not justified.

In order to demonstrate the impact of factors (2) and (3) on the educational requirements, sensitivity analysis was undertaken based on estimated Spanish data for the years 1960-75. For the purposes of this example it was considered that coefficients (2) and (3) formed the basis of Manpower requirements and therefore the impact was judged by measuring the effect of those two elements. More precisely, the future requirements for Higher education graduates and Secondary education were calculated assuming first: only changes in element (1), and second: changes in all three elements. The result indicated that 57% of the total educational requirements in Higher education and 80% in Secondary education were due to elements (2) and (3). Thus the impact of the manpower requirements on the educational planning was quite significant.

(d) The technological change problem

This concerns the effects of the rapid technological change on the occupational structure of the society. It is not a problem appearing in the educational planning activities only. It affects economic planning as well and it does not justify by itself the abandonment of the Manpower planning.

1.4.2 The Social demand approach

Social demand is an ambiguous term which can be defined in different ways. The most commonly used is to mean the aggregate popular demand for education, that is, the sum total demand of individuals who wish to enrol in the various levels and types of the educational system.

Whereas the Manpower requirements approach concentrates on meeting the demand by industry for manpower, the Social demand approach is based upon the notion that planning should be used to affect the supply of educated manpower irrespective of market demand. This approach calls for the projection of the demand by individuals so that educational institutions may adapt themselves to the expected demand and any imbalances between supply and demand which will arise, it is assumed, cancel themselves out over time. Philosophically, the approach commends itself to those who view education as a consumption benefit rather than an investment.

Social demand is certainly the basis on which educational decisions are most frequently made, at least in the industrialised countries and even educational plans that purport to be based on other methods often base a large part of their estimates on what students and their families are thought to desire. The principal problem of this approach is not so much its theoretical basis but the technical difficulties which appear when converting the individual preferences into concrete figures for operational actions.

One of the most important examples in educational planning based on the Social demand approach is the now classic ROBBINS REPORT (1963). It comprises the first comprehensive survey of Higher education in Britain and most of its recommendations have already been implemented.

A. Some methodological aspects of the Social demand approach

The underlying principle which guided the Robbins Report was that "*Courses of Higher education should be available for all who are qualified by ability and attainment to pursue them and who wish to do so.*" (p.8). This principle had then to be converted into specific assumptions about which factors influence the individual's demand for

Higher education. The forecasting techniques can be found in MOSER and LAYARD (1964). For the consequences of the Robbins Report on the development of the British educational system see LAYNARD *et al.* (1968). A brief description of the social trends on which the student projections were based are:

(a) The rising birth rate

The result of this factor was to increase the numbers of the annual age groups in the various branches of the educational system and corresponds to 7% of the increased number of places recommended by the Committee for the years 1973-74 and 1980-81.

(b) The rising level of the educational attainment

This factor, the so-called "school trend" was the most important and it produces an increasing proportion of the age group capable of proceeding to Higher education. Almost 55-60% of the proposed increased number of places is due to "school trend".

(c) The public appetite for Higher education

The Report estimated that this factor will account for 18% and 13% of the additional places for the years 1973-74 and 1980-81 respectively.

(d) Other miscellaneous factors

Foreign students, etc. were held to account for about 17% of the increased number of places.

While the Manpower requirements approach uses as its starting point the required output, the Social demand approach begins from the inputs of the educational system (i.e. students, teachers, etc.). It considers the educational system as a rather complex production system and the various inputs proceed through it from one branch to another. The outputs of the process are the educated people.

The procedure of making estimates, used for the first time in the Robbins Report, as now practised at D.E.S. consists of six stages. The projection of each stage is used as an input to the next stage. (See EDUCATIONAL PLANNING PAPER No.2, 1970, and ARMITAGE, 1973).

These stages are as follows:

Stage 1: The projections of school populations

In this stage estimates of the future numbers of pupils by age are made. The figures depend on the size of age groups as they are given by the Government Actuary's Department, together with the estimated proportion of each age group who will be in school during the planning period.

Stage 2: The projection of the school leavers by age

From stage 1, the figures which represent the entire school population estimates, the projecting numbers corresponding to school leavers by age in any year of the planning period are selected.

Stage 3: The projection of school leavers with a given number of qualifications

At this stage the estimates are obtained by multiplying the estimated number of leavers of each age (stage 2) by the proportions expected to gain a given number of qualifications. (It has been assumed that the proportion of GCE holders will remain the same in the future as it has been in the past.)

Stage 4: Projecting the numbers of entrants into Higher education

Having projected the numbers of leavers with given qualifications, the next step is to determine the number of qualified people who will enter Higher education. This is done according to two criteria; (a) by extrapolating past trends of the various destinations of the leavers, and (b) according to Robbins postulate that: the proportion of qualified

school leavers who enter Higher education should not in the long run fall below the level reached during the 60's. In determining the total number of entrants account was taken of those coming not only from school but from Further education institutions, overseas and employment also.

Stage 5: Calculating the number of places

At this stage the number of places required within the Higher educational institutions is derived from the number of entrants calculated in stage 4 together with appropriate assumptions about the length of time the student spends in Higher education. The device adopted by the Robbins Report is the notion of "effective length of course". This is a single figure and *"it broadly reflects the average duration of courses in a sector as reduced by wastage and as extended by repeating years of course."* (EDUCATION PLANNING PAPER No.2, 1970, p.20).

Stage 6: Calculating Unit costs

The final stage determines the Unit cost per place in each sector of the system. Multiplying by the projected number of places the total Public expenditure on Higher education is obtained.

Chapters 6 and 11 of the Report give a full reference to the detailed procedure set in the Robbins Report.

B. Critique of the Social demand approach

Three main criticisms were made against this approach.

(a) That the projected numbers do not represent the actual societal demand for education. PARNES (1964) noted that the individual's demands depend on the Government's educational policy, since, within certain limits it determines the number of places, tuition fees, etc. On the other hand the Government can arbitrarily boost social demand by increasing the minimum school leaving age, offering free education,

improving grants or increasing the differential wage return for acquiring skills. Therefore there is a circularity in this approach and it cannot provide much help for decision making.

(b) That it does not take into consideration whether the expenditure in education is worthwhile in comparison with other public projects such as health, crime control, etc. In other words it ignores the broader national problems of resource allocation and implicitly assumes that no matter what the educational expenditure is it should be covered.

(c) As BLAUG (1967) put it: *"Social demand projections represent something like a minimum effort at foresight telling the educational planner not what to do, but rather what will happen if he does exactly what he has been doing in the past"*.

Of course all these do not mean that the social demand estimates are worthless. They are indispensable at least for one thing: the assessing in broad terms whether the individual's wishes for education can be met within the existing context of the educational system.

1.4.3 The Cost-Benefit approach

It is now generally accepted that expenditure on education constitutes a form of investment, which yields benefits in the future both to individuals receiving the education and to society as a whole by increasing the productive capacity of its members.

Cost-Benefit analysis involves a systematic comparison of the costs and benefits in order to assess the economic profitability of additional education. All forms of investment imply a sacrifice of present consumption in order to secure future benefits in the form of higher levels of output. It provides a means of appraising these future benefits in the light of the costs that must be incurred in the present.

The theoretical development of the concept of Human Capital, which underlies the Cost-Benefit approach to educational planning, as well as early empirical studies on the subject, can be found in SCHULTZ (1963), BECKER (1964).

A. Some methodological aspects of the Cost-Benefit approach

For the purposes of Cost-Benefit analysis, expenditure in education is taken to mean not the money spent each year but the real resources devoted to education which are therefore not available for any other economic activity. Cost-Benefit analysis can be applied to either individuals (= private Cost-Benefit analysis) or to society as a whole (= social Cost-Benefit analysis).

In both cases the total costs are composed of direct costs and indirect ones (= opportunity costs). The social direct costs include teachers' salaries, institutional costs, etc., and the indirect ones earnings foregone by students. If Cost-Benefit analysis is used for evaluating education as a form of investment for the individual then the direct private costs include fees (minus scholarships), expenditure on books, etc. The indirect costs which constitute the major ones are the earnings foregone by the individual. A common measure of the individual's benefits are the lifetime earnings differentials.

Once the Costs and Benefits of alternative investment activities have been calculated the comparison among them can be achieved by either

$$(a) \text{ The Cost-Benefit Ratio : } \frac{\sum_{t=1}^n \frac{B_t}{(1+r)^t}}{\sum_{t=1}^n \frac{C_t}{(1+r)^t}}$$

$$(b) \text{ The Net Present Value : } \sum_{t=1}^n \frac{B_t}{(1+r)^t} - \sum_{t=1}^n \frac{C_t}{(1+r)^t}$$

- (c) The Rate of Return : that is the discount rate at which the present value of expected Benefits and the present value of Costs are equal

$$\text{i.e. } \sum_{t=1}^n \frac{B_t - C_t}{(1+r)^t} = 0$$

- where: B_t = Expected Benefits in year t
 C_t = Expected Costs in year t
 r = Discount rate
 t = Investment time in years.

B. Critique of the Cost-Benefit approach

A number of objections have been raised against this approach.

BLAUG (1970) summarised them into six groups:

- (a) Earnings differentials reflect differences not only in education but in natural ability, social class background, motivation, etc., in such a way that it is impossible to isolate the pure effect of education and consequently to measure it by the earnings differential.

One of the American surveys by DENISON (1964) suggested that about 2/3 of the extra earnings of the highly educated workers can be explained by their additional education, the other 1/3 is attributable to native ability or social class. Sometimes this adjustment is referred to as the "Alpha coefficient".

- (b) Because of market imperfections differences in earnings do not correspond to differences in productivity and therefore cannot be used as a measure of the direct economic benefits.

To argue that because of market imperfections or trade unions bargaining earnings tell us nothing about the contribution of the various groups to the total output seems a rather exaggerated point of view. On the other

hand it would be absurd to deny that such facts do have an effect on earnings. What all this means is that earnings differentials are some, though not a perfect, measure of the supply and demand of skills.

- (c) Earnings differentials do not reflect the non-economic benefits of education.

The basic issue of Cost-Benefit is the investment aspects of education and how to calculate the direct economic benefits. This approach does not deny the existence of other non-economic benefits of the educational process. On the other hand none of the alternative approaches have succeeded in measuring the indirect effect of education.

- (d) Cost-Benefit analysis assumes full employment of educated people though many countries are experiencing unemployment of University graduates and/or Secondary school leavers.

Even when unemployment conditions exist in a country the method can still be applied by adjusting the earnings in such a way as to take account of the unemployment rates. If there is a lack of appropriate data, some reasonable estimates can be made about the average rate of unemployment and weight the earnings by the rates. Examples of this case concerning India can be found in BLAUG, *et al.* (1969).

- (e) Earnings differentials obtained often from past data reflect the relations between demand and supply which occurred in the past, whereas the main issue of educational planning concerns the future. So this approach is a poor tool for planning.

Cost-Benefit analysis is a form of marginal analysis which measures the effects of small changes of the variables involved. It measures the profitability of past levels of investment in terms of present relationship between supply and demand. The result of these calculations (either a rate of return or a Cost-Benefit ratio or a net present value) can be used for future estimation of profitability only if the present

conditions of supply and demand of educated people are maintained. If the educational authorities are contemplating non-marginal changes then the present rates of return will not continue. In such a case Cost-Benefit analysis is not efficient.

(f) Individuals do not make educational choices on a pure economic basis and therefore private rates of return are meaningless.

This objection misses the point of the Cost-Benefit approach. Estimates of the private rates of return due to education are intended to measure how profitable it is for the individual to spend money on his own education, as a way of increasing his future earnings. They do not assume that the economic benefits are the sole motivation for all educational decisions. Financial benefits are just one, though for many people an important, factor influencing educational choices. MORRIS (1973) noticed that Cost-Benefit calculations from the individual's point of view may throw light on future trends of private demand for certain types, courses, and subjects and so provide evidence for, say, the Social demand approach.

Finally, it might be said, that the most important aspect of the Cost-Benefit approach is that it provides a conceptual framework for the examination of the costs of education in relation to the relative earnings of the educated manpower. An introduction to the Cost-Benefit approach can be found in WOODHALL (1970).

A model of this kind utilising the mathematical technique of Dynamic Programming will be discussed in chapter III.

1.4.4 Other approaches to educational planning

In recent years considerable work in the theory and applications of educational planning has taken place, which cannot be strictly classified into any of the three main approaches discussed so far. Typical examples of this work are the econometric model of TIMBERGEN and BOSS

(1964), STONE (1965), ARMITAGE *et al.* (1967), THONSTAND (1969) etc. BOWEN (1963) presented a survey on the contribution of Economics to educational planning. For recent bibliographies on the economics of education and educational planning see HÜFNER (1968), and BLAUG (1970).

The approaches described in this chapter have been shown to involve very general assumptions about the interrelationships of social, economic and educational factors; detailed applications to educational planning are described in chapter II. Less controversially planning with limited aims at regional or institutional level can also make use of mathematical programming techniques and some examples of this are given also in chapter II.

CHAPTER II

MATHEMATICAL PROGRAMMING AND EDUCATIONAL PLANNING

The purpose of this chapter is twofold. First to describe in very broad terms some of the mathematical programming techniques which have been used in educational planning models and secondly to present a survey of applications of these techniques in various problem areas of educational planning.

Section 2.1 is devoted to programming techniques. The applications are dealt with in sections 2.2 and 2.3.

2.1 The mathematical programming problem and related techniques

Any problem dealing with the maximisation or minimisation of a function of one or more variables may be referred to as an optimisation problem. Such problems have been known for a long time. In the last years a new category of optimisation problems have arisen, in the context of economics particularly, concerning the allocation of scarce resources to competing activities. Problems of this kind are referred to as programming problems. Thus, mathematical programming is a quantitative approach to these problems where some criterion of effectiveness is to be maximised or minimised subject to a set of constraints.

Mathematically the general programming problem can be formulated as follows:

Find a set of variables x_1, x_2, \dots, x_n , such as to

$$\text{Maximise/minimise } z = f(x_1, \dots, x_n) \quad (1)$$

$$\text{Subject to } g_i(x_1, \dots, x_n) \left\{ \leq, =, \geq \right\} b_i, \quad i = 1, \dots, m \quad (2)$$

In the above formulation $g_i(x_1, \dots, x_n)$ are assumed to be specified functions and b_i known constants.

Techniques have been developed to solve special cases of this, e.g. Linear programming, Integer, Quadratic, etc. A few of the most widely used techniques in educational planning are discussed below without any detailed development of the subject.

2.1.1 Linear programming

When in (1) and (2) $z = f(x_1, \dots, x_n) = \sum_{j=1}^n c_j x_j$ and

$g_i(x_1, \dots, x_n) = \sum_{j=1}^n a_{ij} x_j$, $i = 1, \dots, m$, respectively, the

general programming model becomes a linear one and takes the following legitimate forms:

Find x_1, \dots, x_n such as to:

$$\text{Maximise/minimise } z = \sum_{j=1}^n c_j x_j \quad (3)$$

$$\text{Subject to } \sum_{j=1}^n a_{ij} x_j \left\{ \begin{array}{l} \geq \\ = \\ \leq \end{array} \right\} b_i, \quad i = 1, \dots, m \quad (4)$$

$$\text{and } x_j \geq 0, \quad j = 1, \dots, n \quad (5)$$

where $i =$ the number of limited resources ($i = 1, \dots, m$)

$j =$ the number of activities ($j = 1, \dots, n$)

$z =$ the overall measure of effectiveness

$x_j =$ decision variables representing the level of activity j

$c_j =$ the increase in z due to each unit increase of x_j

$b_i =$ the available amount of resource i

$a_{ij} =$ the amount of resource i consumed by each unit of activity j .

Problems with this structure may also arise in contexts other than those concerned with allocation of limited resources among competing activities.

In common Linear programming terminology (3) is the objective function of the problem. The restrictions (4) are called the functional constraints. The restrictions (5) are called the nonnegativity constraints and the input constants a_{ij} , b_i , c_j are the parameters of the model.

It can be shown that any Linear programming problem can be rewritten so that ~~to~~^{it} fits the standard pattern:

Find x_1, \dots, x_n such as to:

$$\text{Maximise} \quad z = \sum_{j=1}^n c_j x_j$$

$$\text{Subject to} \quad \sum_{j=1}^n a_{ij} x_j \leq b_i, \quad i = 1, \dots, m$$

$$\text{and} \quad x_j \geq 0 \quad j = 1, \dots, n$$

In matrix notation the above problem can be represented as:

Find a column vector X such as to:

$$\text{Maximise} \quad z = CX$$

$$\text{Subject to} \quad AX \leq B$$

$$\text{and} \quad X \geq 0$$

where X = a column vector ($n \times 1$)

C = a row vector ($1 \times n$) of the objective function coefficients

B = a column vector ($n \times 1$) combining the R.H.S. of the constraint set

z = a scalar representing the overall value of the objective function.

The structure of the Linear programming model implies that measures of effectiveness are proportional to the x_k and additive in k . The x_k produced are of course not necessarily integers.

The concept of Duality

One important extension of Linear programming is the development of the concept of Duality. This term implies that to every Linear programming problem corresponds a dual problem. Given a Linear programming problem (the primal) in the standard form discussed above, its dual is:

Find y_1, \dots, y_m such as to

$$\text{Minimise} \quad y_0 = \sum_{i=1}^m b_i y_i$$

$$\text{Subject to} \quad \sum_{i=1}^m a_{ij} y_i \geq c_j \quad j = 1, \dots, n$$

$$\text{and} \quad y_i \geq 0 \quad i = 1, \dots, m$$

Apart from the fact that the formulation of the dual problem arises in the computation, the economic interpretation of it is interesting. The dual variables y_i ($i = 1, \dots, m$) represent the current unit contribution of all resources that would be consumed by one unit of activity j , $y_0 = \sum_{i=1}^m b_i y_i$ the total implied value of the

resources consumed by the activities and finally the constraints

$$\sum_{i=1}^m a_{ij} y_i \geq c_j, \quad (j = 1, \dots, n)$$

indicate that the contribution of the resources to the criterion of effectiveness must be at least equal to the unit contribution of activity j .

Special types of Linear programming problems

Probably the most important special type Linear programming problems which appear frequently in the educational planning literature are those of the classical transportation problem and the very closely related assignment problem.

The general transportation problem is concerned with distributing any commodity from any group of supply centres, called resources, to any group of receiving centres, called destinations, in such a way as to minimise total distribution costs.

The formulation of this problem becomes:

Find x_{ij} ($i = 1, \dots, m$, $j = 1, \dots, n$) such as to

$$\text{Minimise } z = \sum_{i=1}^m \sum_{j=1}^n c_{ij} x_{ij}$$

$$\text{Subject to } \sum_{j=1}^n x_{ij} = S_i, \quad i = 1, \dots, m$$

$$\sum_{i=1}^m x_{ij} = d_j, \quad j = 1, \dots, n$$

$$\text{and } x_{ij} \geq 0 \quad \text{all } i, j$$

where z = the total distribution cost

m = the number of sources ($i = 1, \dots, m$)

n = the number of destinations ($j = 1, \dots, n$)

s_i = supply from source i

d_j = demand at destination j

c_{ij} = cost per unit distributed from source i to destination j

x_{ij} = the number of units to be distributed from source i to destination j .

In general $\sum_{i=1}^m s_i = \sum_{j=1}^n d_j$. If this condition is not satisfied a

fictitious source or destination can be introduced to convert it into the above pattern. Any Linear programming problem which fits this special structure regardless of its physical context is of transportation type.

The assignment problem is concerned with the allocation of resources to activities on a one to one basis. There is a cost associated with assignment and the objective is to determine how the assignments should be made in order to minimise the total costs. This problem is a special type of the transportation problem with the assignees being interpreted as sources each having a supply of one and the assignments as destinations with a demand of one. Thus the formulation now becomes:

Find x_{ij} ($i = 1, \dots, m$, $j = 1, \dots, n$) such as to

$$\text{Minimise } z = \sum_{i=1}^n \sum_{j=1}^n c_{ij} x_{ij}$$

$$\text{Subject to } \sum_{j=1}^n x_{ij} = 1 \quad i = 1, \dots, m$$

$$\sum_{i=1}^m x_{ij} = 1 \quad j = 1, \dots, n$$

$$x_{ij} \geq 0 \quad \text{all } i, j$$

2.1.2 Integer programming

Very often the decision variables of a problem make sense only if they have integer values. If, in the general Integer programming problem, the restriction $x_j = 0, 1, 2, \dots$ (for all or some j) is added, an Integer problem arises. If the problem is further more constrained by imposing $x_j \leq 1$ then the Integer problem becomes a "zero-one" problem. The mathematical representation of an Integer problem takes the following form:

Find x_1, \dots, x_n such as to

$$\text{Maximise/minimise } z = \sum_{j=1}^n c_j x_j$$

$$\text{Subject to } \sum_{j=1}^n a_{ij} x_j \left\{ \begin{array}{l} \geq \\ = \\ \leq \end{array} \right\} b_i \quad i = 1, \dots, m$$

$$\text{and } x_j = 0, 1, 2, \dots \text{ for all or some } j = 1, \dots, n$$

In practice a common approach for these cases is to ignore the Integer restrictions and by employing the Simplex procedure to generate optimal solutions (if they exist) and then to round-off the non-integer values. However this approach does not always give feasible solutions or when it does the rounded-off values might not be optimal.

From a computational point of view there are three approaches in solving an Integer programming problem: the Implicit enumeration procedure, the Branch and Bound procedure and Gomory's Cutting Plane method.

2.1.3 Goal programming

Goal programming is a special extension of Linear programming. It is applicable when multiple conflicting goals are involved in a situation and a hierarchy of importance is desirable among them.

Goals might simply be meeting the functional constraints of the problems or might involve an entirely separate function derived from the constraints. Most real world decision problems involve multiple objectives. To deal with these using a simple objective function means combining them, which might involve estimating relative importance and may often mean dealing with goals which are not easily expressible even in the same units. In Goal programming, instead of trying to maximise or minimise the objective function directly as Linear programming does, the deviations between goals and what can be achieved under the given set of constraints are to be minimised. These deviations, the slack variables in Linear programming, take on a new significance in Goal programming. They may be positive, indicating the overachievement of the particular goal, or negative, indicating the underachievement of the goal.

One of the characteristics of this technique is that the objective function is no longer restricted to be a cardinal criterion (i.e. profits, costs, etc.) but it rather provides an ordinal one. To this end negative and/or positive deviations about the goal must be ranked according to the "preemptive" priority factors. In this way the low order goals are considered only after high order goals are achieved.

If there are goals in several ranks of importance, the preemptive priority factor P_j ($j = 1, \dots, k$) should be assigned to the negative and/or positive deviational variables. These factors generally have the relationship $P_1 \gg P_2 \gg \dots P_j \gg P_{j+1}$ where \gg means "very much greater than".

The general Goal programming problem can be defined as:

$$\text{Minimise } \begin{bmatrix} P_1 & P_2 & \dots & P_m \end{bmatrix} \begin{bmatrix} d_1^+ \\ \vdots \\ d_m^+ \end{bmatrix} + \begin{bmatrix} P_1 & \dots & P_m \end{bmatrix} \begin{bmatrix} d_1^- \\ \vdots \\ d_m^- \end{bmatrix}$$

$$\text{Subject to } \begin{bmatrix} a_{11} & \dots & a_{1n} \\ \vdots & & \vdots \\ a_{m1} & \dots & a_{mn} \end{bmatrix} \begin{bmatrix} x_1 \\ \vdots \\ x_n \end{bmatrix} - \begin{bmatrix} 1 & \dots & 0 \\ \vdots & & \vdots \\ 0 & \dots & 1 \end{bmatrix} \begin{bmatrix} d_1^+ \\ \vdots \\ d_m^+ \end{bmatrix} + \begin{bmatrix} 1 & \dots & 0 \\ \vdots & & \vdots \\ 0 & \dots & 1 \end{bmatrix} \begin{bmatrix} d_1^- \\ \vdots \\ d_m^- \end{bmatrix} = \begin{bmatrix} b_1 \\ \vdots \\ b_m \end{bmatrix}$$

$$\text{and } x_j, d_j^+, d_j^- \geq 0 \quad \begin{matrix} j = 1, \dots, n \\ i = 1, \dots, m \end{matrix}$$

where m = the number of goals

n = the number of decision variables

x_j = a decision variable $j = 1, \dots, n$

d_i^+ = the deviation variable associated with goal i indicating an overachievement of this goal

d_i^- = the deviation variable associated with goal i indicating an underachievement of this goal

P_i = a preemptive priority factor associated with goal i

b_i = the i^{th} goal.

For a full treatment of Goal Programming see (LEE, 1972).

2.1.4 Nonlinear programming

Any programming problem which does not fit the special linear programming structure presented in section 2.1.1, can be classified as a Nonlinear problem. In this sense the Integer programming, the Zero-one programming and the Goal programming problems are Nonlinear.

Also by making various assumptions about the nature of the objective function and the functional constraints we can formulate special subclasses of Nonlinear problems, e.g. Quadratic programming. Certain types of those problems can be found in HADLEY (1964). A number of computerised algorithms is provided by HIMMELBLAU (1972).

The special case of Dynamic programming will be discussed in detail in chapter III.

2.2 Mathematical programming models in educational planning

In the remaining parts of this chapter applications of mathematical programming techniques to problem areas of educational planning are presented. The presentation is given in three levels according to the model's coverage, national, regional or institutional.

2.2.1 Programming models at national level

Because of the very general nature of the models at national level it has not been thought profitable to list all variables and constraints. Instead an account only of the structure will be given.

The most ambitious models link the educational system to the manpower and economic systems. Recent linear models of this type are by ADELMAN (1966) applied to Argentina, GOLLADAY and ADELMAN (1972) applied to Morocco and BENARD (1967) applied to France. The particular applications produce some modifications but the broad outlines of all of these are similar. A somewhat more limited linear model which optimises the state of the educational system when it is supplied with given resources is presented by BOWLES (1969) and applied to Nigeria and Greece.

In all these cases the state of the educational system is described by a series of vectors one in each time period, giving the new enrolments in the different levels of the educational system. The constraints governing these take a similar form in all the models: the enrolments $N_p^{(t-1)}$ at level p in period $(t-1)$, less a proportion λ_p who drop out during the course and a proportion μ_p who do not continue either with education or in employment produce a number of qualified people $(1 - \lambda_p)(1 - \mu_p) N_p^{(t-1)}$; these may be considered as wholly distributed in known proportions as workers $W^{(t)}$, teachers $T^{(t)}$, and continuing students $N^{(t)}$ (as in GOLLADAY and ADELMAN, 1972), or as wholly assigned but in unknown amounts to particular skill categories of work, teaching at particular levels or continuing education at particular levels as in ADELMAN (1966). BENARD (1967) similarly allows the proportions joining the labor force and continuing in education to be variable. BOWLES (1969) simply requires the admissions to level p at time t to be less than or equal to the output at $(t-1)$, of all levels which qualify a student to enter level p . There is in each case a restriction that the entrants to the educational system cannot exceed the number of potential students in the population and

there may be requirements for a minimum growth rate in education requiring at least a certain ~~proportion~~^{proper} of $N^{(t-1)}$ to continue (BERNARD, 1967) or $N^{(t)} \geq N^{(t-1)}$ (ADELMAN, 1966) and also some assignments of the dropouts, $\lambda_p N^{(t-1)}$, to some work level or even to low level teaching (GOLLADAY and ADELMAN, 1972).

The educational system requires trained persons as teachers and monetary resources for equipment, buildings, etc.; these are constraints connecting $N^{(t)}$, the enrolments at t , with $T^{(t)}$ the vectors of new teachers recruited at t and $B^{(t)}$ the resources devoted to buildings at time t . The intake $N^{(t)}$ is converted by multiplying by the appropriate matrices into a requirement vector for teachers and this must be less than or equal to the existing teaching force allowing in some cases (GOLLADAY and ADELMAN, 1972, BOWLES, 1969) for recruitment of foreign teachers; similarly, depending on $N^{(t)}$, a requirement vector for school buildings can be produced, which must be satisfied by the original stock together with additions allowing for depreciation. There may be limits on the maximum recruitment of teachers or on maximum importation of foreign teachers.

The BOWLES (1969) model incorporated the above constraints within an overall framework of limited resources devoted to education; i.e. a limit on the amount of resource i in period t ; this gives an overall inequality governing the enrolments in period t and in previous periods. It was implemented with about 200 activities and 450 constraints. The objective function to be maximised was the sum, over the planning period, of the present value of the lifetime incomes of the students $N^{(t)}$ less their incomes had they not received education at that level, less the present value of the recurrent costs by the enrolments less the capital costs of providing the student places (this is an aggregate Cost-Benefit objective function).

The other three models all incorporated links with the economic system connecting the supply of workers $w^{(t)}$ with vectors of production. The GOLLADAY and ADELMAN (1972) scheme allowed for educated workers to count as efficiency units, whereas BENARD (1967) converted certain work skills with certain educational levels; both then combined the work force with resources and investments, including imports, foreign capital, and allowed the resulting production to be used for consumption, exports or further investment, including investment in education. The objective functions were however somewhat different. ADELMAN (1966) considered

- (1) maximise discounted sum of G.N.P. over the planning period
- (2) maximise the growth in G.N.P., i.e. $(GNP)_{end} - (GNP)_{initial}$
- (3) minimise the discounted sum of net foreign capital inflow.

This was an implicit manpower requirements model.

GOLLADAY and ADELMAN (1972) carried out extensive calculations involving a number of objective functions and a parameter linear programming analysis. As well as (1) and (2) above they used

- (1) maximise a weighted vector of employment
- (2) maximise a weighted vector of education enrolments
- (3) minimise a weighted vector of unemployment
- (4) minimise weighted vectors of expatriate workers or teachers
- (5) maximise consumption.

(1) - (4) are social aims of the above.

BENARD (1967) defined a simple social preference function which he stated as: maximise the present discounted value, over the planning period of

- (1) the sum of successive increases in personal consumption
- (2) the residual value of the capital equipment installed in the productive sector

- (3) the residual value of capital equipment installed in education
- (4) the value of educated individuals to the labor force beyond the planning horizon.

In weighting these components of the objective function he made use of the dual variables in the model to assign shadow prices to resources. His model is again based on an aggregate Cost-Benefit approach with implicit manpower requirements.

A general model of training at one or many levels was given by BALINSKI and REISMAN (1972), BALINSKI (1974). Here the aim is very much more modest: it assumes levels of education p and periods t as before but now adds known requirements d^t , for all levels and periods t , i.e. it is a straight manpower requirements model. The objective function is a sum of possible nonlinear penalty functions depending on the defect or excess of the actual manpower with the required manpower over each level and each period, together with educational costs. There is also a functional relationship, not necessarily linear, between enrolments, dropouts, and those qualified who actually join the labor force. Thus the previous $(1 - \lambda_p)(1 - \mu_p) N_p^t$ now becomes:

$$L_p \left\{ N_p^t - \lambda_p(N_p^t) \right\}$$

where $\lambda_p(n)$ is the number of dropouts from an enrolment of n at level p .

and $L_p(m)$ is the number joining the labor force from a number m of qualified personnel.

The student flow equations now take the form

$$S_{p+1,t+1} = S_{p+1,t} + \lambda_{p+1}(N_{p+1}^t) + L_p \left\{ N_p^t - \lambda_p(N_p^t) \right\} - d_{p+1}^t$$

i.e. the available pool $S_{p+1,t+1}$ of manpower qualified at level $(p+1)$, in period $(t+1)$, is that present at period t $\left\{ S_{p+1,t} \right\}$ plus those of the N_{p+1}^t who dropped out of higher training $\left\{ \lambda_{p+1}(N_{p+1}^t) \right\}$, plus those who qualified and entered the labor force less d_{p+1}^t required in period t . Also

$$N_{p+1}^t = N_p^{t-1} - \lambda_p (N_p^{t-1}) - L_p \left\{ N_p^{t-1} - \lambda_p (N_p^{t-1}) \right\}$$

since the students who enrol at time t , for level $p+1$, are those who leave qualified at level p and ^{have} not dropped out or joined the labor force.

The objective function is now to minimise

$$\sum_t \theta^{t-1} \left\{ \sum_p c_p^t (N_p^t) + \sum_p g_p^t (S_p^{t+1}) \right\}$$

where $c_p^t (N)$ is the cost of enrolment N , at level p , in period t

and $g_p^t (S)$ is the penalty cost of having either a shortage or a surplus of manpower.

COMAY *et al.* (1973) developed a model within the framework of Cost-Benefit analysis concerning the option value of education, in which Dynamic programming was used. The basic relation was given by

$$V_{ke} = q_{ke} V_{ko} + (1 - q_{ke}) P_{ke} \frac{1}{(1+r)^{\tau_e}} (V_{eo}^- - C_e^-) + \\ + (1 - q_{ke})(1 - P_{ke}) \frac{1}{(1+r)^{t_e}} (V_{e^*} - C_e)$$

where k, e are educational stages; V_{ke} is the net discounted income following stage k , assuming optimal decisions after e ; V_{ko} is the net discounted income (= n.d.i) following stage k and entry into the labor market; V_{e^*} is the net discounted income assuming optimal decisions at k and after it; V_{ko}^- is the n.d.i. for a dropout at stage k , C_e is the discounted costs of stage e for a completer; C_e^- is the discounted costs for a dropout; P_{ke} is the probability of dropping out of stage e ; q_{ke} is the probability of not being accepted into stage e ; r is the discount rate; t_k is the length of stage k in years and τ_k is the length of stage k in years for a dropout.

A numerical example relating to the U.S. educational system was also presented.

A survey of mathematical models at national level, from several countries, are quoted in O.E.C.D. (1973) and the accompanied volume O.E.C.D. (1974). DAVIS (1968) provides also several models based on Linear programming within the context of planning human resource development.

2.2.2 Programming models at the regional level

Numerous applications reported in the literature deal with planning problems arising at the local or district level. To facilitate the discussion the various models are grouped by topic areas:

(a) School desegregation and busing

Although operational researchers have been studying these problems for only a few years diverse literature is now available. Most of them have attempted to utilise Linear programming algorithms as a means of assigning students to schools to achieve racial balance or by using other operational research techniques to design bus routes and schedules to transport students to schools. (Similar techniques are required if the object is to produce a satisfactory mixed ability rather than race.)

The problem can be stated as follows:

Given: the distribution by race of students in a community; the location and capacity of each school; the ethnic composition desired at each school and the mass transportation in the community, Find: a plan of assignment of students to schools which achieves the desired ethnic composition at each school; and it minimises some performance criterion (e.g. the student's daily travelling time, or the distance travelled, etc.).

The above defines, in practical terms, a distribution problem where the areas of student residence (= tracts) are sources, the schools are destinations and each ethnic group is a commodity. The costs are the distance travelled.

Mathematically the problem can be formulated as follows:

Let $i =$ a tract $i = 1, \dots, m$

$j =$ a school $j = 1, \dots, n$

$k =$ a race $k = 1, \dots, K$

$x_{ijk} =$ number of students of race k , in tract i , assigned to school j

$d_{ijk} =$ distance students of race k , in tract i travel to school j .

$a_{ik} =$ percentage of students of race k , in tract i

$p_i =$ total number of students in tract i

$S_j =$ school capacity of school j

$\epsilon_{jk} =$ upper bound on the percentage of students of race k assigned to school j

$\delta_{jk} =$ lower bound on the percentage of students of race k assigned to school j

$$\text{Minimise } z = \sum_{i=1}^m \sum_{j=1}^n \sum_{k=1}^K d_{ijk} x_{ijk}$$

A. Assigning students of race $k = 1, \dots, K$, from all tracts

$i = 1, \dots, m$, to schools $j = 1, \dots, n$.

$$\sum_{j=1}^n x_{ij1} = a_{i1} p_i \quad i = 1, \dots, m$$

\vdots

$$\sum_{j=1}^n x_{ijk} = a_{ik} p_i \quad i = 1, \dots, m$$

B. Limits on school capacity

$$\sum_{i=1}^m \sum_{k=1}^K x_{ijk} \leq S_j \quad j = 1, \dots, n$$

C Limits on the racial composition of the schools

$$\delta_{j1} \sum_{i=1}^m \sum_{k=1}^K x_{ijk} \leq \sum_{i=1}^m x_{ij1} \leq \epsilon_{j1} \sum_{i=1}^m \sum_{k=1}^K x_{ijk}$$

$$\vdots \qquad \qquad \qquad \vdots \qquad \qquad \qquad \vdots \qquad \qquad \qquad \vdots$$

$$\delta_{jk} \sum_{i=1}^m \sum_{k=1}^K x_{ijk} \leq \sum_{i=1}^m x_{ijk} \leq \epsilon_{jk} \sum_{i=1}^m \sum_{k=1}^K x_{ijk}$$

$$j = 1, \dots, n$$

$$x_{ijk} \geq 0 \qquad \text{all } i, j, k$$

CLARKE and SURKIS (1968) formulated the same problem with additional constraints concerning upper limits on the allowable daily transportation time and walking distance per student. The objective was to minimise the total daily one way transportation time,

i.e. Minimise
$$z = \sum_{i=1}^m \sum_{j=1}^n \sum_{k=1}^K t_{ij} x_{ijk}$$

where t_{ij} = the daily one way transportation time, in minutes, over a minimal route from the i th tract to the j th school.

A general purpose computer system, called MINTRAN, was developed to solve the school desegregation problem. It comprises ~~of~~ eight computer programs called JS1-JS8, together with the MPS/360, the general purpose Mathematical Programming System of I.B.M.

The first six, JS1-JS6, compute the minimal time rates from each tract to each school which are compatible with the allowable transportation time. Program JS7 formulates the problem to fit MPS/360 format. A solution (if any exist) is then reached by the MPS/360. The last program JS8 produces the final output.

The MINTRAN system was tested with data of elementary schools in Brooklyn, New York.

The student racial percentages of the three ethnic groups used were 19.6% (Puerto Ricans), 24.2% (Negroes), 62.2% (others).

There were 201 elementary schools with 214,793 total capacity and 783 tracts. Ethnic composition for each of the schools were 7-35% for Puerto Ricans, 12-57% for Negroes and 25-81% for the others. The walking distance limit was 0.227 miles and the daily one way transportation time limit 20 minutes.

The Brooklyn school desegregation problem proved too difficult to solve because of its size.

HECKMAN and TAYLOR (1969) focused on technical details of the L.P. approach. Some alternative constraint possibilities were discussed together with certain improvements concerning computer's execution time. KOENINGSBERG (1968) proceeded basically on the same lines as the others did, with two modifications. First he categorised the students within a tract by H age groups and second the objective function was of the type

$$z = \sum_{i=1}^m \sum_{j=1}^n \sum_{k=1}^K \sum_{h=1}^H x_{ijkh} (d_{ij})^2$$

where h = an age group $h = 1, \dots, H$

x_{ijkh} = number of students in tract i , of age h , race k , assigned to school j

d_{ij} = distance from tract i to school j .

In a recent paper STIMSON and THOMSON (1974) developed six hypothetical examples under various assumptions about the racial distribution of students in the tract and the desired upper and lower limits of each school. They considered only three schools, two races and four tracts. The objective functions used were of the type

$$z = \sum_{i=1}^4 \sum_{j=1}^3 \sum_{k=1}^2 d_{ijk} x_{ijk}$$

and
$$z = \sum_{i=1}^4 \sum_{j=1}^3 \sum_{k=1}^2 (d_{ijk})^2 x_{ijk}$$

All the examples were run on a computer using the revised Simplex algorithm. The dual problems were solved too. Several points were made about the sensitivity of the optimal solution by changing the parameters of the model. The authors emphasised the fact concerning the information which can be extracted from the dual solution of the problem. For instance, consider the values of the dual variables at optimality, which correspond to the constraints (B) (= limits on school capacity). They represent a measure of the effect on the objective function (= the total distance travelled, say) by a change of one unit in the student capacity of a school. For those schools, where the dual values are zero, there is an excess of capacity and therefore their facilities could be expanded.

Another attempt at the same problem is the procedure developed by BELFORD and RATLIFF (1972). This problem was formulated as a minimum cost flow problem in a single commodity network. The advantage of their model over the Linear programming approach is that it permits the use of more efficient solution methods and also provides integer answers.

The mathematical formulation is as follows:

$$\begin{aligned}
 \text{Minimise} \quad & \sum_{i=1}^L \sum_{j=1}^S d_{ij} \left\{ f(l_i, s_j) + f(l'_i, s'_j) \right\} \\
 \text{Subject to} \quad & \sum_{j=1}^S f(l_i, s_j) = b_i \quad i = 1, \dots, L \\
 & \sum_{j=1}^S f(l_i, s_j) - u_j + v_j = \bar{b}_j \quad j = 1, \dots, S \\
 & \sum_{j=1}^S f(l'_i, s'_j) = K_i - b_i \quad i = 1, \dots, L \\
 & \sum_{i=1}^L f(l'_i, s'_j) - v_j + u_j = \bar{K}_j - \bar{b}_j \quad j = 1, \dots, S
 \end{aligned}$$

$$0 \leq f(\ell_i, s_j) \quad i = 1, \dots, L; \quad j = 1, \dots, S$$

$$0 \leq f(\ell_i', s_j') \quad i = 1, \dots, L; \quad j = 1, \dots, S$$

$$0 \leq u_j \leq \left[\overline{pK}_j \right] - \overline{b}_j \quad j = 1, \dots, S$$

$$0 \leq v_j \leq \overline{b}_j - \langle p\overline{K}_j \rangle \quad j = 1, \dots, S$$

and all variables are integer

where: S = number of schools ($j = 1, \dots, S$)

L = number of locations in a district ($i = 1, \dots, L$)

p, \overline{p} = the lower and upper bound on the percentage of blacks assigned to each school respectively

\overline{K}_j = a positive integer indicating the students assigned to school j

$\left[\overline{pK}_j \right]$ = is the largest integer less than or equal to \overline{pK}_j

$\langle p\overline{K}_j \rangle$ = is the smallest integer greater than or equal to $p\overline{K}_j$

ℓ_i = the black part of a location i

ℓ_i' = the white part of a location i

S_j = the black part of a school j

S_j' = the white part of a school j

$f(\ell_i, s_j)$ = a decision variable indicating the black students assigned to school j from location i

$f(\ell_i', s_j')$ = a decision variable indicating the number of white students assigned from location i to school j

u_j = the amount by which the number of black students assigned to school j exceeds \overline{b}_j

v_j = the amount by which the number of white students assigned to school j exceeds $\overline{K}_j - \overline{b}_j$

\overline{b}_j = the desired number of blacks assigned to school j

The above model was used to generate a desegregation plan for the school system of Gainesville, Florida.

For the elementary school system there were 6687 students of which approximately 30% were black. The total number of tracts was 248 and the race distribution of each school 25-35% black. No student should be forced to travel more than 10 miles. A student was considered as being bussed to a school only if he lived further than two miles from the school to which he was assigned.

A similar analysis was performed for the middle and high school system.

LUTZ *et al.* (1972) approached the school desegregation problem differently. The essential element in their model is that students attend their home school but each school is responsible for a certain specialty area such as science, maths, etc. Students taking specialty courses have to travel to these schools. The objective is to minimise the weekly student travelling time.

Although the model can be formulated as a zero-one Quadratic programming problem, because of computational difficulties a computer program was written to provide an efficient though not necessarily optimal solution.

The formulation for scheduling one section course is given below:

Let N = be number of one section courses ($i = 1, \dots, N$)

c_{ik} = number of students requesting both courses i and k

T = number of time blocks. (the term "time block" was utilised to distinguish among periods of different lengths, instead of the traditional definition of periods. There were five different types of time blocks. For example a time block might be: 2 hours - five days a week course)

t_{pq} = an element of the "time block" matrix

$$t_{pq} = \begin{cases} 1 & \text{if time block } p, \text{ conflicts with time block } q \\ 0 & \text{otherwise} \end{cases} \quad (p, q = 1, \dots, T)$$

K_i = a set of time blocks allowed for course i

$$x_{ij} = \begin{cases} 1 & \text{if course } i \text{ is scheduled in time block } j \\ 0 & \text{otherwise} \end{cases} \quad i = 1, \dots, N, \quad j \in K_i$$

And the problem can be written as:

$$\text{Minimise} \quad \sum_{i=2}^N \sum_{j=1}^{i-1} \left\{ c_{ij} \left\{ \sum_{p \in K_i} \sum_{q \in K_j} t_{pq} x_{ip} x_{jq} \right\} \right\}$$

$$\text{Subject to} \quad \sum_{p \in K_i} x_{ip} = 1 \quad i = 1, \dots, N$$

$$\text{and} \quad x_{ij} = 0, 1 \quad i = 1, \dots, N, \quad j \in K_i$$

This 0-1 quadratic form can be transformed into a 0-1 linear form. But if we try to do so, for a problem with, say, $K_i = 5$ and $N = 10$ we need to add 123750 new variables and constraints.

Another group of problems closely related to the assignment of students to schools in order to achieve racial desegregation is the one related to scheduling the bus routes. The situation becomes even more complex if we consider a racial balance as well. The problem consists of issues like the determination of a route and a time schedule for each bus, with the objective of minimising the number of routes and/or the minimisation of mileages, etc.

One approach to this problem is the one attempted by NEWTON and THOMAS (1969), who utilised a modified algorithm of the "travelling salesman problem". They programmed a heuristic procedure in FORTRAN IV to generate near optimal solution. The procedure consists of two steps. First the shortest route, which starts at the school, visits every stop once and terminates at the school, is determined. Second this single near to optimal route is then partitioned into individual bus routes which satisfy the bus capacity, bus loading policy and the passenger's time constraints.

Several references on the school busing problem can be found in STIMSON and THOMSON (1974).

(b) Optimal school location

O'BRIEN (1969) provided a model for planning the location and size of urban schools. He introduced a methodology concerning the factors that determine the effectiveness of decisions about school planning. Several submodels are presented related with the location of the school, the costs, the social composition of the school attendance area, etc.

Although no attempt has been made to optimise an overall objective function, the various submodels allow a systematic study of the relationships between school location decisions and other objectives such as the minimisation of total students' travelling time.

(c) Financing local schools and salary scheduling

This is another area of applications of Mathematical programming techniques and it concerns the allocation of funds among district schools.

The purpose of the model is to minimise the state's financial commitments without seriously affecting the financial support for educational expenditures at the school district level.

BRUNO (1971) developed a model applied to the California junior college foundation program. The basic relations are as follows:

$$\text{Minimise } S = \sum_{i=1}^n ADA_i Y_i$$

$$\text{Subject to } A_i X + Y_i - 600 - E_i = 0 \quad i = 1, \dots, n \quad (2)$$

$$E_i - 600 \psi \leq 0 \quad (3)$$

$$\sum_{i=1}^n ADA_i Y_i + \left\{ \sum_{i=1}^n ADA_i \right\} X - T = 0 \quad (4)$$

$$\sum_{i=1}^n ADA_i Y_i - .50T \leq 0 \quad (5)$$

$$\sum_{i=1}^n ADA_i Y_i - .37T \geq 0 \quad (6)$$

$$\left\{ \sum_{i=1}^n A_i ADA_i \right\} X - .629T \leq 0 \quad (7)$$

$$\left\{ \sum_{i=1}^n A_i ADA_i \right\} X - .500T \geq 0 \quad (8)$$

$$X \geq 5 \quad (9)$$

$$X \leq 50 \quad (10)$$

where: i = a district

n = number of districts ($i = 1, \dots, n$)

ADA_i = Average Daily Attendance in district i

A_i = the assessed situation/ ADA_i in district i , modified and adjusted as necessary by the state. This value is used to measure local ability at the school district.

X = the uniform state-mandated computational tax rate required to qualify for the state support program.

Y_i = the total state aid to district i

F = the foundation level for the state support program

T = total local funds used by the program

E_i = the amount of funds per ADA, in addition to the foundation level F

ψ = the optimal percentage spread (that is the % spread required to either maximise or minimise the particular objective function).

In other papers the same author BRUNO (1969, 1969a, 1970) utilised a L.P. model for selective salary evaluation schemes for district school personnel. The model is capable of incorporating factors which are considered important by the teacher unions, school board, etc. such as

the type of area in which the school is located (= X_1), the subject matter area being taught (= factor X_2), the supervisory responsibilities of the personnel (= factor X_3), and so on.

Once the factors X_1, X_2, \dots, X_{10} have been defined it is possible to describe each function in the organisational hierarchy by means of two equations: one representing the highest salary and the other the lowest salary, i.e.:

$$\sum_{i=1}^{10} a_i X_i = \lambda_j \quad j = 1, \dots, n$$

$$\sum_{i=1}^9 \beta_i X_i = \sigma_j \quad j = 1, \dots, n$$

where: a_j = the highest rated characteristics associated with those factors appropriate to function j

β_j = lowest rated characteristics associated with factors appropriate to function j

X_j = factors associated with function j

λ_j = theoretically highest salary to be paid within function j

σ_j = theoretically lowest salary to be paid within function j

The various constraints concern the total budget available as well as the percentage of the total budget spread for each function j .

The objective function can take many forms, depending upon the criteria used by the school district. For example if the school district desires to attract young inexperienced teaching personnel then the corresponding j could be maximised.

(d) Vocational training and establishing posts in schools

McNAMARA (1971) illustrated how Linear programming might be used as an aid to evaluate alternative decisions about the efficient allocation of vocational funds to district schools. The state

educational system is viewed as a set of input-output relationships, which can be designed so that the use of vocational funds will be optimised.

The model provides the decision maker with some estimated numbers of future graduates who could be produced to fill critical occupational shortages existing in the labor force. Clearly the model lies within the conceptual framework of the manpower requirements approach of planning.

The utilised procedure requires the completion of two phases. Phase one provides the information necessary to calculate the parameters of the Linear program. Phase two involves the actual operation of the Linear programming scheme, which generates the optimal solutions. We give below a broad description of phase two, assuming that the parameters used have already been calculated in phase one. The Linear program is:

$$\text{Maximise } z = \sum_{i=1}^m \sum_{j=1}^n x_{ij} \quad (1)$$

$$\text{Subject to } \sum_{j=1}^n x_{ij} \leq d_i \quad i = 1, \dots, m \quad (2)$$

$$t_{ij} \leq x_{ij} \leq t'_{ij} \quad \begin{matrix} i = 1, \dots, m \\ j = 1, \dots, n \end{matrix} \quad (3)$$

$$t_{ij} = m_{ij} y_{ij2} \quad \begin{matrix} i = 1, \dots, m \\ j = 1, \dots, n \end{matrix} \quad (4)$$

$$t'_{ij} = n_{ij} y_{ij2} \quad \begin{matrix} i = 1, \dots, m \\ j = 1, \dots, n \end{matrix} \quad (5)$$

$$T_j = g_j \sum_{i=1}^m y_{ij2} \quad j = 1, \dots, n \quad (6)$$

$$\sum_{i=1}^m x_{ij} \leq T_j \quad j = 1, \dots, n \quad (7)$$

$$\sum_{j=1}^n h_{ij} x_{ij} \leq H_i \quad i = 1, \dots, m \quad (8)$$

$$\text{and } x_{ij} \geq 0 \quad \text{all } i, j$$

- where: n = the number of counties $j = 1, \dots, n$
- m = the number of national programs $i = 1, \dots, m$
- x_{ij} = the output of additional students required in occupational program i , county j
- d_i = the unsatisfied demand for occupational program i
(d_i have been found from phase one)
- t_{ij} = the minimum increase which is desired in the output of program i , in county j
- \bar{t}_{ij} = the maximum increase in x_{ij}
- m_{ij} = the minimum percentage of increase in program i , county j
- n_{ij} = the maximum percentage of increase in program i , county j
- y_{ij2} = the output of program i , in school j during the second year of the planning period
- T_j = the maximum increase which is desired in the total output of all m programs in county j
- g_j = the maximum percentage of increase for all m programs in county j
- h_i = the fixed amount of educational funds allocated to the public schools in the n counties for each additional student enrolled in program i
- r_{ij} = the percentage of students in program i , county j necessary to produce the desired number of graduates at the completion of the two year program
($r_{ij} \geq 1.0$ for all i, j)
- H_i = the total amount of vocational education funds available for reallocation to the public schools to support additional students in program i .

Constraint set (2) represents the market constraints based on the results of phase one.

Constraint sets (3), (4), (5), (6), (7) represent the school capacity constraints in terms of increased number of graduates.

Constraint set (8) are budgeting constraints.

PSOINOS and XIROCOSTAS (1973) discussed several aspects of a Centralised educational system susceptible to optimisation techniques and

developed a model which deals with the problem of establishing teaching posts in schools according to certain criteria of the system's effectiveness (e.g. minimising teacher's overtime, etc.).

One of the problems studied, uses as effectiveness criterion the minimisation of the total overtime and idle time per teacher. The problem was formulated as a Dynamic programming one and a mathematical description of it is given below:

Let n = the number of schools $i = 1, \dots, n$

N = the number of teachers

x_i = the number of established teaching posts at school i

A_i = the number of teaching hours per teacher

$$V_L(x_i) = \frac{A_i - hx_i}{x_i} \quad (= \text{overtime per teacher}) \quad i = 1, \dots, n$$

h = the standard weekly teaching hours per teacher

$$V = \sum_{i=1}^n \frac{|A_i - hx_i|}{x_i} = \text{the total overtime}$$

$f_n(N)$ = minimum total sum of overtime and idle time per teacher,

and the recurrence relation takes the form:

$$f_n(N) = \min_{\text{all } x_n} \left\{ |V_n(x_n)| + f_{n-1}(N - x_n) \right\}$$

2.2.3 Mathematical programming models at the institutional level

The educational expansion in size, complexity and costs has made the need for more systematic planning and management inevitable.

SCHROEDER (1973) suggested that one way of classifying the various models is to group them in four categories:

- (a) Planning-Programming-Budgeting Systems
- (b) Management Information Systems
- (c) Simulation models
- (d) Mathematical models.

For the purposes of this study only one subclass of the fourth category will be dealt with, namely, the Optimisation models. The central theme of these is that they cover a wide range of activities which take place within an academic institution, (e.g. administration, teaching, research, etc.).

(a) Allocating available resources in a University

A common problem to all Universities is that of allocating faculty staff among alternative teaching tasks and research of different types under a reasonable set of restrictions concerning available teaching and/or research manhours, facilities, etc.

Winkelmann, as it is quoted in FOX and SENGUPTA (1968), considered the following Linear programming formulation of the problem of allocating faculty time between teaching and research.

Let p_{jk}^i = the price of the i^{th} staff member in the k^{th} section of the j^{th} course

$$c_{jk}^i = \begin{cases} 1 & \text{if the } i^{\text{th}} \text{ individual teaches the } k^{\text{th}} \text{ section of} \\ & \text{the } j^{\text{th}} \text{ course} \\ 0 & \text{otherwise} \end{cases}$$

p_{Rk}^i = the price of the k^{th} unit of research by the i^{th} member

$$c_{Rk}^i = \begin{cases} 1 & \text{if the } i^{\text{th}} \text{ individual produces the } k^{\text{th}} \text{ unit of research} \\ 0 & \text{otherwise} \end{cases}$$

B_i = the number of units of teaching and research that can be allocated to the i^{th} staff member.

Then the problem is:

$$\text{Maximise } \sum_{i=1}^m \sum_{j=1}^n \sum_{k=1}^K p_{jk}^i c_{jk}^i + \sum_{i=1}^m \sum_{k=1}^K p_{Rk}^i c_{Rk}^i$$

$$\begin{aligned} \text{Subject to } \sum_{j=1}^n \sum_{k=1}^K c_{jk}^i + \sum_{k=1}^K c_{Rk} &= B_i \quad (= \text{faculty availability}) \\ \sum_{k=1}^K \sum_{i=1}^m c_{jk}^i &= B_j \quad (= \text{course availability}) \\ \sum_{i=1}^m \sum_{k=1}^K c_{Rk} &= B_R \quad (= \text{research time available}) \end{aligned}$$

The assumption of linearity is probably not very realistic and various refinements are possible to remove this assumption. For instance, we can postulate a quadratic objective function. The overall parameter is the calculation of prices p of research and teaching which is done very broadly on the basis of net return value to an average student benefiting from teaching and an approximate estimate of research costs.

A more generalised version of the above scheme has been considered by PLESSNER *et al.* (1968) at Iowa State University. The Department has been involved in both undergraduate and post-graduate teaching, awarding B.Sc., M.Sc., Ph.D. degrees as well in research activities. Five categories of students are recognised: students receiving a B.Sc. degree, those receiving M.Sc. and three types of Ph.D. The technique used is Parametric linear programming.

The objective function is assumed to be the additional discounted lifetime income of graduating students over the four year period. There are nine activities in total. Apart from the first five which are concerned with the above student category, the model also considers new faculty hired, research by existing faculty members, research by new faculty and office space addition. ($j = 1, \dots, 9$).

The first five objective function coefficients c_j ($j=1, \dots, 5$) were computed as follows:

$$c_j = R_j \frac{(1+r)^{n_j - k_j} - 1}{r(1+r)^{n_j} - 1} - F_j \frac{(1+r)^{m_j - k_j} - 1}{r(1+r)^{m_j} - 1}$$

(j = 1, ... 5)

where: R_j = starting annual salary
 F_j = annual income foregone
 r = interest rate (= 4.3%)
 k_j = years elapsed from the start of the program to the year of admission
 n_j = expected worklife + k_j
 m_j = n_j + years of study

For the remaining coefficients c_6 was computed by assuming the starting salary of a new faculty member and calculating the total discounted salary from the entering time to the system until the end of the program. c_7 and c_8 are defined as "the total research expenditures, other than faculty and student salaries, per hour of faculty research", and c_9 is the cost per unit of such facilities.

Constraints. There are sixteen constraints. Constraints (1), (2) concern manpower for undergraduate and postgraduate teaching. (3) and (4) posts of existing and new manpower. (5) and (6) manpower for undergraduate and postgraduate administration. (7) office space. (8) and (9) admission of undergraduates and graduates. (10) and (11) ratios of Ph.D (student) instructors and of M.Sc. to total graduates. (12) manpower of research assistants. (13) dissertation supervision requirements. (14) existing manpower transferable to undergraduates teaching. (15) new manpower transferable to administration, and (16) manpower for available research activities.

Technology coefficients a_{ij} ($i = 1, \dots, 16, j = 1, \dots, 9$)

The a_{ij} coefficients were estimated from existing departmental data, from a survey conducted among faculty members and from some common practice regarding the curricula.

A few a_{ij} coefficients have been calculated in the way shown below:

$$a_{1j} = \frac{h_1}{s_1} t_j, \quad a_{2j} = \frac{h_2}{s_2} t_j \quad \text{for } j = 1, \dots, 5$$

where: h_i = the number of hours an experienced teacher devotes to a class which meets three times a week for 45 minutes. ($i = 1, 2$)

s_i = average class size $i = 1, \dots, 2$

t_j = number of classes a student attends in the course of three quarters ($j = 1, \dots, 5$).

The information about h_i was supplied by the faculty members, s_i from departmental data, t_j from frequent practice.

The novel aspect of the model is that it suggests not merely the optimum number of the students but also the allocation of existing teaching staff between teaching, research, the allocation between undergraduate, postgraduate etc.

By changing the various parameters of the model the sensitivity of the optimal solution was tested. It was also shown that certain a_{ij} had more effect on the objective function than others.

More general models of this kind, as well as a comprehensive systems approach to resource allocation in educational planning can be found in FOX (1972) and OECD (1972).

A crucial and realistic element in the administration of higher education is the one of setting priorities among conflicting multiple objectives. A model which takes account of that issue is developed by LEE and CLAYTON (1972) using Goal programming. The scope of the model is

limited to planning in one College within the University and the planning horizon is of one year. The main objective is to allocate optimally human and physical resources and to satisfy the imposed constraints and desired priorities. A brief description is given below:

Priority structure: M_7 = maintain the necessary requirements of accreditation (= top priority)
 M_6 = assume adequate salary increases for the academic staff
 \vdots \vdots
 M_1 = minimise costs (= lower priority)

Constraints: There are seven groups of constraints but here only a few of them will be illustrated.

Constraints of accreditation

$$\text{e.g. } \sum_{i=1}^5 y_i - 0.75 \left\{ x_8 + \sum_{i=1}^6 y_i \right\} + d_3^- - d_3^+ = 0$$

Constraints for the number of academic staff

$$\text{e.g. } \sum_{i=1}^7 x_i + \sum_{i=1}^8 y_i + d_6^- - d_6^+ = 91$$

Constraints for the distribution of academic staff

$$\text{e.g. } 0.07 \left\{ \sum_{i=1}^8 x_i + \sum_{i=1}^5 y_i \right\} - x_2 + d_8^- - d_8^+ = 0$$

Objective function:

$$\begin{aligned} \text{Minimise } z = & M_7 \sum_{i=1}^3 d_i^- + M_6 d_{23}^+ + M_5 d_{22}^- + 2M_4 d_5^- + 2M_4 d_7^- + M_4 d_4^- + M_4 d_6^- + \\ & + M_3 \sum_{i=8}^{11} d_i^- + M_3 d_{13}^- + M_3 d_{18}^- + M_3 d_{12}^+ + M_3 \sum_{i=14}^{17} d_i^+ + M_3 d_{19}^+ + \\ & + M_2 d_{20}^+ + M_1 d_{21}^+ \end{aligned}$$

where: x_i ($i = 1, \dots, 9$), y_i ($i = 1, \dots, 9$) are variables indicating the number of various groups of teaching staff with different academic qualifications, e.g.
 x_2 represents the number of graduate teaching assistants,
 y_1 represents the number of assistant professors with Ph.D. etc.
 d_i^+ , d_i^- are deviational variables indicating the overachievement or underachievement of the various goals, represented by the constraints.

The model provides three types of solutions:

- identification of the inputs (= resources) requirements to attain the desired goals.
- the degree of goal attainments with the given inputs
- the degree of goal attainments under various combinations of inputs and goal structure.

SCHROEDER (1974) utilises Goal programming too in a model for resource planning for a University. Although this model has some of the goal structures of the previous one of LEE and CLAYTON (1972) it concerns several academic units (departments or schools) on a multiyear planning horizon.

The goal programming formulation is as follows:

Let

f_{ij}^t = faculty level in academic unit j , rank i , at the beginning of period t

x_{ij}^t = number of new faculty hired at the beginning of period t , unit j , rank i

w_j^t = number of teaching assistants in unit j , at the beginning of period t

z_j^t = number of staff in unit j , at the beginning of period t .

Unless otherwise specified $i = 1, \dots, m$, $j = 1, \dots, n$,
 $t = 1, \dots, T$.

Constants

c_{ij}^t = salary per faculty member, unit j , rank i , period t

g_j^t = faculty goal level desired in unit j , period t

- b_{ij}^t = desired proportion of faculty in rank i , unit j , period t
 D_{ij}^t = proportion of faculty who stay from period t to $t+1$, rank i , unit j .
 p_{ij}^t = proportion of faculty promoted from rank $i-1$ to rank i , during period t , in unit j
 U_j^t = upper bound on the number of faculty who can be hired in period t , unit j
 d_j^t = desired teaching assistant-to-faculty ratio, in unit j , period t
 a_j^t = cost per teaching assistant during period t , in unit j
 R_j^t = desired staff-to-faculty ratio in unit j , period t
 A_j^t = cost per staff member in unit j , period t
 r_j^t = proportion of staff who stay from period t to $t+1$, (by choice), in unit j
 B^t = total budget available during period t .

Constraints:

$$f_{ij}^{t+1} = D_{ij}^t f_{ij}^t + x_{ij}^{t+1} + p_{ij}^t f_{i-1,j}^t \quad (\text{Faculty flow})$$

$$f_{ij}^1 = f_{ij}^0 + x_{ij}^1 \quad \text{where } f_{ij}^0 = \text{given, } t = 1, \dots, T$$

$$\sum_{i=1}^m x_{ij}^t \leq U_j^t \quad (\text{Maximum hiring})$$

$$z_j^{t+1} \geq r_j^t z_j^t \quad (\text{Staff reduction})$$

$$\sum_{i=1}^m \sum_{j=1}^n c_{ij}^t f_{ij}^t + \sum_{j=1}^n a_j^t w_j^t + \sum_{j=1}^n A_j^t z_j^t \leq B^t \quad (\text{Budget payroll})$$

Goal constraints:

$$\sum_{i=1}^m f_{ij}^t + y_{j1}^{t-} - y_{j1}^{t+} = g_j^t \quad (\text{Teaching-load goal})$$

$$w_j^t - d_j^t \sum_{i=1}^m f_{ij}^t + y_{j2}^{t-} - y_{j2}^{t+} = 0 \quad (\text{Teaching-assistant ratio goal})$$

$$z_j^t - R_j^t \sum_{i=1}^m f_{ij}^t + y_{j3}^{t-} - y_{j3}^{t+} = 0 \quad (\text{Staff ratio goal})$$

$$f_{ij}^t - b_{ij}^t \sum_{i=1}^m f_{ij}^t + y_{ij4}^{t-} - y_{ij4}^{t+} = 0 \quad (\text{Faculty-rank distribution goal})$$

Objective function:

$$\begin{aligned} \text{Minimise } & \sum_{j=1}^n \sum_{t=1}^T \left\{ M_{j1}^{t-} y_{j1}^{t-} + M_{j1}^{t+} y_{j1}^{t+} + M_{j2}^{t-} y_{j2}^{t-} + M_{j2}^{t+} y_{j2}^{t+} + M_{j3}^{t-} y_{j3}^{t-} + \right. \\ & \left. + M_{j4}^{t-} y_{j4}^{t-} + M_{j4}^{t+} y_{j4}^{t+} \right\} + \sum_{i=1}^m \sum_{j=1}^n \sum_{t=1}^T \left\{ M_{ij4}^{t-} y_{ij4}^{t-} + M_{ij4}^{t+} y_{ij4}^{t+} \right\} \end{aligned}$$

where y^{t-} 's and y^{t+} 's are the deviational variables from the goals.

A third model utilising Goal programming has been developed by WALTERS *et al.* (1976). It concerns planning and decision making for a five year period. The model includes faculty staffing goals, career constraints, teaching and course levels and budget constraints.

(b) Assigning faculty to courses

A special subclass of the general allocation of resources problem is the one of assigning faculty to courses. One of the first successful applications is the model developed by ANDREW and COLLINS (1971) whose procedure has been applied for many semesters in the Electrical Engineering Department of the University of Minnesota. This is a Linear programming model and its basic formulation is as follows:

- Let
- i = a faculty member ($i = 1, \dots, m$)
 - j = a course ($j = 1, \dots, n$)
 - $p(i,j)$ = the preference rating indicated by the i th faculty member of the j th course
 - $e(i,j)$ = the effectiveness of the i th member for the j th course as determined by the Department Chairman
 - $x(i,j)$ = the number of sections of the j th course assigned to the i th member
 - w = a weighting factor chosen between 0 and 1
 - $c(j)$ = the number of sections of the j th course to be assigned
 - $f(i)$ = the number of sections which constitute a full teaching load for the i th member.

then the problem is to:

$$\text{Maximise } \sum_{i=1}^m \sum_{j=1}^n x(i,j) \left\{ w(i,j) + (1-w) e(i,j) \right\}$$

$$\text{Subject to } \sum_{i=1}^m x(i,j) = c(j) \quad j = 1, \dots, n$$

$$\sum_{j=1}^n x(i,j) \leq f(i) \quad i = 1, \dots, m$$

TILLET (1975) provided a slightly different formulation of the same problem in the Secondary school context. His model was a Zero-one Integer Program. A broad description of this model is given below:

Let m = the number of teachers ($i = 1, \dots, m$)

n = the number of courses ($j = 1, \dots, n$)

$$x(i,j,k) = \begin{cases} 1 & \text{if teacher } i \text{ is assigned to teach} \\ & k \text{ sections of course } j \\ 0 & \text{otherwise} \end{cases}$$

$a(i)$ = the number of course-sections to which teacher i is to be assigned

$b(j)$ = the number of sections of course j to be allocated

k = number of sections of course j

$k = 1, 2, \dots, c(i,j)$ where $c(i,j) = a(i)$ or $b(j)$ whichever is less

$e(i,j)$ = the effectiveness of teacher i for course j

$k e(i,j)$ = the contribution to total effectiveness of any $x(i,j,k)$ which has the value of 1

$p(i,j,k)$ = the preference rating teacher i , for the assignments of k sections of course j

$k p(i,j,k)$ = the contribution to the total preference of any $x(i,j,k)$ which has the value of 1

$w(i)$ = the weighting assigned by the department to the preference of teacher i $0 \leq w(i) \leq 1$

$u(i)$ = the maximum number of courses acceptable to teacher i

then the formulation of the problem is:

$$\text{Maximise } z = \sum_{i=1}^m \sum_{j=1}^n \sum_{k=1}^c c(i,j) d(i,j,k) x(i,j,k)$$

$$\text{Subject to } \sum_{j=1}^n \sum_{k=1}^c k, x(i,j,k) = a(i) \quad i = 1, \dots, m \quad (1)$$

$$\sum_{i=1}^m \sum_{k=1}^c k, x(i,j,k) = b(j) \quad j = 1, \dots, n \quad (2)$$

$$\left. \begin{aligned} \sum_{k=1}^c x(i,j,k) &\leq 1 \\ i &= 1, \dots, m \\ j &= 1, \dots, n \end{aligned} \right\} (3)$$

$$\sum_{j=1}^n \sum_{k=1}^c x(i,j,k) \leq m(i) \quad i = 1, \dots, m \quad (4)$$

$$x(i,j,k) = \begin{cases} 1 \\ 0 \end{cases} \text{ for all } i, j, k$$

- Constraints (1) indicate that all teachers receive precisely the total number of sections for which they are available
- " (2) indicate that all sections of all courses are allocated
- " (3) indicate that from the assignments only one occurs
- " (4) indicate that no teacher is assigned more than the agreed number of courses.

(c) Classroom allocation

In the design of a new campus the type and size of classroom, laboratories, offices, etc. constitute a problem. GRAVES and THOMAS (1970), developed a Linear programming model for finding the location-allocation of classrooms which maximises the attainment of academic location preference while at the same time minimises the construction costs.

Let m = number of departments

n = classroom categories

x_{ij} = the number of classrooms of capacity type j , for department i which are to be located with laboratories and faculty offices

y_{ij} = the number of classrooms of capacity type j for department i which are to be located in a general congregation of classroom type facilities

p_{ij} = preference measure for classroom type x_{ij}

q_{ij} = preference measure for classroom type y_{ij}

c_{ij} = cost of construction for each classroom type x_{ij}

d_{ij} = cost of construction for each classroom type y_{ij}

C = total budgeted cost of construction of classrooms for the group of department under consideration

t_{ij} = total number of classrooms of category j , which are authorised for department i and budged for construction.

The model then takes the following form:

$$\text{Maximise } z = \sum_{i=1}^m \sum_{j=1}^n (p_{ij}x_{ij} + q_{ij}y_{ij}) \quad (1)$$

$$\text{Subject to } \sum_{i=1}^m \sum_{j=1}^n (c_{ij}x_{ij} + d_{ij}y_{ij}) \leq C \quad (2)$$

$$x_{ij} + y_{ij} = t_{ij} \quad j = 1, \dots, n \quad (3)$$

$$\vdots$$

$$x_{mj} + y_{mj} = t_{mj}$$

$$\text{and } x_{ij} + y_{ij} \geq 0 \quad (4)$$

Although the variables are inherently integers, the Linear programming procedure was utilised.

In order to find both the maximum preference and the cost minim solution the following three step process has been taken:

- (a) Solve the above mentioned problem to maximise the academic location preference.
- (b) Set the objective function (1) equal to optimal value, say \bar{z} .
- (c) Solve the following problem:

$$\text{Minimise } a = \sum_{i=1}^m \sum_{j=1}^n (c_{ij}x_{ij} + d_{ij}y_{ij})$$

$$\text{Subject to } \sum_{i=1}^m \sum_{j=1}^n (p_{ij}x_{ij} + q_{ij}y_{ij}) = \bar{z}$$

$$y_{ij} + y_{ji} = t_{ij} \quad \text{for all } \begin{matrix} i = 1, \dots, m \\ j = 1, \dots, n \end{matrix}$$

The same authors CRAVES and THOMAS (1976) dealt with the problem of locating departments at a multicampus University.

Mathematically their model takes the following form:

$$\text{Minimise } z = \sum_{k=1}^n \sum_{r=1}^n \sum_{i=1}^N \sum_{j=1}^N c_{rk} f_{rk} \left\{ y_{jk} \{1 - y_{ik}\} \right\} \left\{ y_{ik} \{1 - y_{jr}\} \right\} \quad (1)$$

$$\text{Subject to } \sum_{j=1}^n \left\{ \sum_{j=1}^N f_{ij} y_{jk} \right\} \leq A_k \quad k = 1, \dots, n \quad (2)$$

$$\sum_{k=1}^n y_{jk} = 1 \quad j = 1, \dots, N \quad (3)$$

$$y_{jk} = 0, 1 \quad \text{all } j, k \quad (4)$$

where: z = the value of the objective function

n = the number of campuses

N = the number of departments

k, r = campus indices $k, r = 1, \dots, n$

i, j = department indices $i, j = 1, \dots, N$

$$y_{jk} = \begin{cases} 1 & \text{if department } j \text{ is established at campus } k \\ 0 & \text{otherwise} \end{cases}$$

f_{ij} = flow of FTE (= full time equivalent) students from department i to department j

A_k = constraint constant for campus k in terms of FTE student population

c_{kr} = relative cost per FTE student associated with travel from campus k to campus r .

The objective is to minimise the sum of the intercampus flow costs in the context that N academic department can be located at n campus.

Constraint set (2) sums the "sizes" of those academic departments located on a particular campus to assure that the solution is feasible. Constraint set (3) requires that somewhere among the n campuses a given department j is placed. Constraint set (4) insure that the decision variables may only have the integer values zero-one, i.e. that a department cannot be split between two or more locations.

The solution method of this zero-one problem has been found by implicit enumeration.

(d) Timetabling

There have been a number of approaches to computerise the construction of timetables for educational establishments (BARRACLOUGH, 1965; ALMOND, 1966; YULE, 1968). However the above models did not attempt finding optimal solutions. LAWRIE (1969) formulated the timetabling problem as an integer linear one and produced a computational procedure based not on units of the teacher or the class but on larger units of departments, year groups of pupils, and layouts. (The layout is a statement of the curriculum and its organisation for a group of pupils, e.g. all the pupils in the first, say, year of the school.)

(e) Planning curriculum - Test construction and servicing

The application of optimising procedures in this area of educational planning is rather limited.

CORREA (1965) reported an application of Integer programming in the preparation of an educational curriculum. Given the courses and a list of prerequisites the following formulation results in the best solution of which courses should be taught:

$$\text{Maximise } z = \begin{bmatrix} p_i \\ x_i \end{bmatrix}$$

$$\begin{aligned} \text{Subject to } n_h x_h &\leq \begin{bmatrix} S_{hj} \end{bmatrix} \begin{bmatrix} x_j \end{bmatrix} \\ r &\geq \begin{bmatrix} c_i \end{bmatrix} \begin{bmatrix} x_i \end{bmatrix} \\ x_j &= 0, 1 \end{aligned}$$

where: s_i = a course $i = 1, \dots, n$

$$x_i = \begin{cases} 1 & \text{if course } s_i \text{ is taught} \\ 0 & \text{otherwise} \end{cases}$$

S_{ij} = a $(n \times n)$ matrix of prerequisites

$$s_{ij} = \begin{cases} 1 & \text{if subject } j \text{ is a prerequisite of subject } i \\ 0 & \text{if it is not} \end{cases}$$

and $s_{ii} = 1$ by convention

n_i = the number of prerequisites of subject i

c_i = cost of teaching course i

p_i = benefits of course i
(benefits of the prerequisites are not included)

r = amount of resources available.

A different approach to the curriculum planning problem has been presented by TAFT and REISMANN (1967). They utilised a composite equation for the educational potential for one particular course based on the learning process theory and propose a heuristic algorithm for the selection of best (or near best) sequence for the subject presentation. Applications of this method can be made at all levels of the educational system.

The basic function used is:

$$P = MH \left\{ 1 - S^{-L(t_L)^2} \right\} S^{-At_0}$$

where: P = the educational potential of a student at time t

S = the type of subject matter

H = the total time devoted to subject matter S for teaching and repetition

L = type of learner

M = method of teaching

t_L = represents the cumulative amount of time that a given subject has been studied in the classroom

R = the total number of times a given subject has been taught

t_0 = the decay (or forgetting) time.

FEUERMAN and WEISS (1973) have developed a model for a test construction and scoring which utilises the "knapsack" problem of ~~linear~~ ^{dynamic} programming. The method applies to ~~the~~ examination~~s~~ of the ~~type of~~ multiple question ~~type~~.

For a heterogeneous examination, an examination where the various questions carry a different weight, the student is asked to attempt all the questions. The instructor, in turn, would then proceed to mark all the questions and assign a score for each question. After that he selects, via the "knapsack" algorithm a subset of the questions answered in which the total weight does not exceed a weight limit w . The sum of the scores for all the questions in the subset is a maximum for the student over all other possible subsets.

The mathematical model is as follows:

Let w_i = the weight of each of the questions in the examination
($i = 1, \dots, n$)

v_i = the value of student's score on each question
($0 \leq v_i \leq w_i$)

$x_i = \begin{cases} 1 & \text{if the } i\text{th question is selected} \\ 0 & \text{otherwise} \end{cases}$

The problem then is:

Maximise $Z = x_1 v_1 + \dots + x_n v_n$

Subject to $x_1 w_1 + \dots + x_n w_n \leq w$

and $x_i = \begin{cases} 0 \\ 1 \end{cases}$ for all i .

For a comprehensive review of Mathematical programming models in educational planning see McNAMARA (1973), CASE and CLARKE (1967), WEITZ (1969). Numerous applications of Operational research techniques can be found also in OECD (1969) and in the PROCEEDINGS OF THE SYMPOSIUM ON OPERATIONS ANALYSIS OF EDUCATION (1969).

2.3 A note on the contribution of Operational research to educational planning

From the above discussed models it is clear that Operational research techniques have been widely used in assisting educational planners and administrators in solving a great variety of problems. Although not all of them have been dealt with adequately, as ACKOFF (1975) put it *"The outputs of such studies have not been insignificant. They have reduced waste of valuable human and material resources and they have led to greater efficiency of operations"*.

However, some of the limitations of the Operational research contribution to educational planning should be mentioned. Certain aspects of education, such as the quality of education, are difficult to quantify and state mathematically. Furthermore, basic assumptions of the mathematical techniques used may often be violated, since they do not correspond too well with the system being modelled. For instance, in the school busing problem the proportionality assumption of Linear programming does not hold (HECKMAN and TAYLOR, 1969).

Finally, the solution to a mathematical programming model of an educational planning problem, should be judged as a specific one and not as "the solution" to it.

Further discussion on the role of Operational research in socio-economic problem areas can be found in STIMSON and THOMSON (1975).

CHAPTER III

A DYNAMIC PROGRAMMING MODEL

In the first section of this chapter a brief account of the educational system as it operates in the U.K. is given. Since our purpose is to present the general picture detailed aspects have been ignored. A basic description of Dynamic programming is the subject of section 3.2. The remaining sections are devoted to a single mathematical model concerning an individual's decision making process through the educational system by utilising the technique of Dynamic programming.

3.1 Outline of the educational system

Basically, the education system can be divided into three parts: the Primary education (including Nursery), the Secondary, and the Post compulsory education.

Primary education. The compulsory schooling starts at the age of five and lasts until the age of eleven. The aims at this stage are to provide the children a full scope for their individual development.

Secondary education. Provision of Secondary education could take many forms. Until the early sixties the great majority of schools were of three types: grammar - "modern" - technical, organised on a selective basis depending on the results of tests taken at about the age of 11. Later on a new type of comprehensive school took over, based on a non-selective attitude. The comprehensive school has increased in importance in recent years, although some controversy still exists, and the system is rather moving toward this direction, ending in this way the selective secondary school. Today almost 60% of the maintained secondary schools are comprehensive.

Post secondary education. The minimum school leaving age of all children is now 16 (raised from 15 in 1972). At this age pupils have a variety of options, i.e., they may discontinue their formal education and enter employment or they may continue at school full time or at some kind of Further education establishment.

At the end of the compulsory schooling, there are two types of examinations: the Certificate of Secondary Education (C.S.E.) and the General Certificate of Education (G.C.E.). G.C.E. examinations are conducted at two levels, an "Ordinary" ('O' level) and an Advanced ('A' level). Ordinary level papers are usually taken at the end of a five year course in a secondary school. Advanced level examinations are taken two years later.

Further education. This term is commonly used to mean Post-secondary education excluding Universities and Colleges of education. It covers a variety of courses and qualifications awarded from 'O' level to post-graduate studies. Conventionally they are classified into non-Advanced and Advanced. The former are those courses reaching standards not above 'A' level standards (e.g. O.N.D., O.N.C. etc.).

First degree courses at Further education establishments are open to those having appropriate G.C.E. 'A' level or equivalent qualifications. Minimum entrance requirements are similar to those imposed by Universities, i.e. five G.C.E. passes of which at least two are at Advanced level. The final degree must be approved by the Council for National Academic Awards (C.N.A.A.). Other Advanced qualifications awarded in Polytechnics, Colleges of Further Education, Technical Colleges are the two year Higher National Diploma (= H.N.D.) and the two-to-three year Higher National Certificate (= H.N.C.) in a wide range of technical subjects. Non-Advanced qualifications, practical in content designed mainly for industrial requirements, are those of O.N.D., O.N.C., and City and Guilds, etc.

Teacher training colleges. Colleges of education were (in 1972) the main source of supply of teachers for the Primary and Secondary education. The minimum entry requirements are five passes at 'O' level, although in practice two-thirds of the entrants have at least one 'A' level pass. The duration of the courses for the Certificate of Education is three years full time, and opportunities exist for a fourth year to obtain a B.Ed. Also one year courses are provided for graduates and for holders of specific qualifications.

Considerable changes are now (1976) taking place in the Colleges after the JAMES Report (1974). These will mean ultimately the abolition of the Teacher's certificate and possibly the widespread introduction of a two year Diploma of Higher education which can serve as a basis for an Ordinary B.Ed. (one further year) or Honours (two further years) or as an introduction to other qualifications. However in what follows the structure as in 1972 is taken as a basis since the statistics available are based on that situation.

Universities. University degree courses generally extend over three or four years, although in some fields (Medicine, Architecture) five or six years of study are required. In most universities an "Ordinary" (= General) degree, or an Honours (= Special) degree can be taken. Over 75% of students take Honours degrees.

Further study or research for one or two years and at least three years are required for a Master's degree and Ph.D. respectively. A pictorial representation of the educational system is given at scheme 1.

3.2 Introductory concepts of Dynamic programming

Dynamic programming is not only an optimisation technique but it is also a way of viewing a problem. It mainly deals with optimising

THE EDUCATIONAL SYSTEM OF ENGLAND & WALES

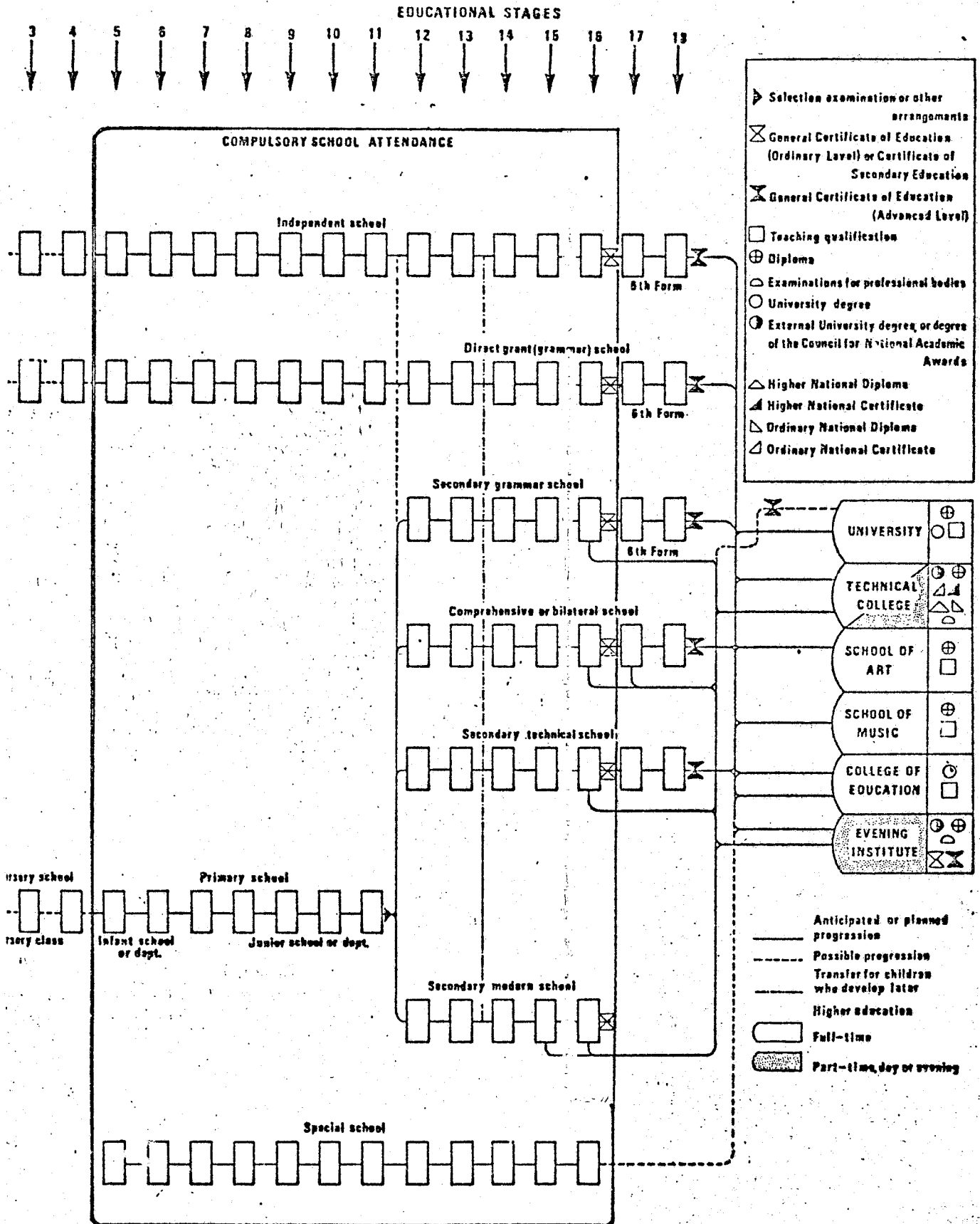

Scheme 1

multistage decision processes. In such a process a sequence of decisions is made which optimises (maximises or minimises) some predefined objective function.

The essence of this procedure is to subdivide the entire decision problem into smaller subproblems which can be handled more efficiently from a computational point of view and find the optimal solution. We then enlarge our search by considering more subproblems and try to find the current optimal solution from the previous one. Continuing in this manner we cover the entire problem.

A main difference between Dynamic programming and the optimisation techniques described in chapter II is that the latter describes the entire decision process in one set of inequalities and optimises the objective function. Dynamic programming on the other hand splits the entire problem into smaller ones.

A major disadvantage is that a general purpose preprogrammed computational algorithm does not exist as in the case of Linear programming.

3.2.1 Basic characteristics of Dynamic programming problems

Although there is a lack of a well defined formulation scheme which can be applied to all Dynamic programming problems, HASTINGS (1973), McMILLAN (1975), HILLIER and LIEBERMAN (1974) noted that some common features do exist. These characteristics are discussed below:

Stage $\{n\}$. A stage might be seen as a single step in the decision process. Very often a stage is identifiable with a time interval. However the precise definition of a stage depends on the content of the problem.

State $\{i\}$. By this term we mean all the relevant information about the situation under consideration. It is a relevant term depending

on the depth of the analysis undertaken. In general we may say that the 'states' identify all possible conditions in which the system might be at a particular stage. The number of states may be either finite or infinite, and so one (or many) discrete (or continuous) variables may be used to define it.

Action $\{k\}$. At each stage a policy decision is required. The effect of the decision is to transform the current state into a state associated with the next stage.

Plan (or Policy). A set of actions constitute a plan. An Optimal plan is that sequence of actions which yields the optimal value of the objective criterion.

Return $\{r(n,i,k)\}$. A return is some quantity generated by the system due to the transition of the system from one state to another. Usually it takes the form of profit or cost or distance or the consumption of a resource, etc. In general its effect is cumulative.

Value of a state under action k $\{f(n,i,k)\}$ is the value of the objective function when the system starts in state i , at stage n and action k (one of the available actions at that state) is taken followed by the best plan subsequently. Furthermore, to each state at the terminal stage ($n = 1$) a defined value is assigned.

The principle of optimality. This relates an optimal policy for the remaining stages (given the current stage and state) with the policy adopted in previous stages.

As stated by BELLMAN (1957) an optional policy has the property that, whatever the initial state and initial decision are, the remaining decisions must constitute an optimal policy with regard to the state resulting from the first decision.

Sufficient conditions to justify the above principle can be found in HASTINGS (1973).

Recursive relationship. This is the mathematical expression of the optimal value of a state i at stage n and the optimal value of a subsequent state j at stage $(n-1)$. That is

$$f(n,i) = \text{maximum/minimum } \left\{ f(n,i,k) \right\}$$

over all actions k

and $f(n,i,k) = r(n,i,k) + f(n-1,j)$, when the returns are additive where $r(n,i,k) =$ the return due to action k

$f(n-1,j) =$ the Optimal value of the successor state j .

Since the returns, the states, the stages, the form of the recursive relationship, the terminal values at $n=1$, etc. have been decided upon, the solution procedure, as described in HASTINGS (1973), runs as follows:

(a) The optimal value and optimal action for each state, for all stages, are determined by employing the recursive relation starting from stage $(n=1)$ and working backwards to stage $(n=2)$, stage $(n=3)$, etc. until all stages have been considered.

(b) The optimal value and optimal action of each state from step (a) are selected. The sequence of optimal decisions constitutes then an optimal policy, (= optimal plan).

3.2.2 Deterministic-Probabilistic Dynamic programming problems

One way of classifying Dynamic programming problems is by looking at whether the successor state j can be completely determined at the current stage. Using this criterion we distinguish between deterministic and probabilistic Dynamic programming problems.

A. Deterministic Dynamic programming

A Dynamic programming problem can be categorised as a deterministic one when the state j at the next stage $(n-1)$ is completely determined by state i . action k at the current stage n .

The common structure for Deterministic dynamic programming is illustrated in scheme 2, which can be interpreted as follows: suppose that the system is at stage n , state i and some action k is taken by the decision maker. The objective function at state (n,i) , under action k is denoted by $f(n,i,k)$. The system by moving from (n,i) to $(n-1,j)$ under action k , generates a return $r(n,i,j,k)$. The optimal value of state $(n-1,j)$ is denoted by $f(n-1,j)$. By combining the immediate return $r(n,i,j,k)$ and the optimal value $f(n-1,j)$ we take the objective value at (n,i) i.e.

$$f(n,i,k) = r(n,i,j,k) + f(n-1,j)$$

Therefore the recursive relationship over all possible actions is

$$f(n,i) = \underset{\text{all } k}{\text{maximum/minimum}} \left\{ r(n,i,j,k) + f(n-1,j) \right\}$$

B. Probabilistic Dynamic programming

By introducing an element of uncertainty at some point of the decision process, the deterministic version can be generalised into a stochastic one. Some common types of stochastic Dynamic programming problems encountered in the field of Operational Research are given below:

- (1) At each state several decisions exist, but the decision maker cannot make his decisions with certainty. It is rather a probability distribution that determines the decisions taken. This kind of problem might be called the stochastic-policy problem.
- (2) Another type is the one where, given the state and action variables i and k respectively, the next state j at stage $(n-1)$ is not completely determined, but it is a probability distribution which determines what the next state will be.
- (3) The new state j , is deterministically known, but the immediate return is only statistically known.

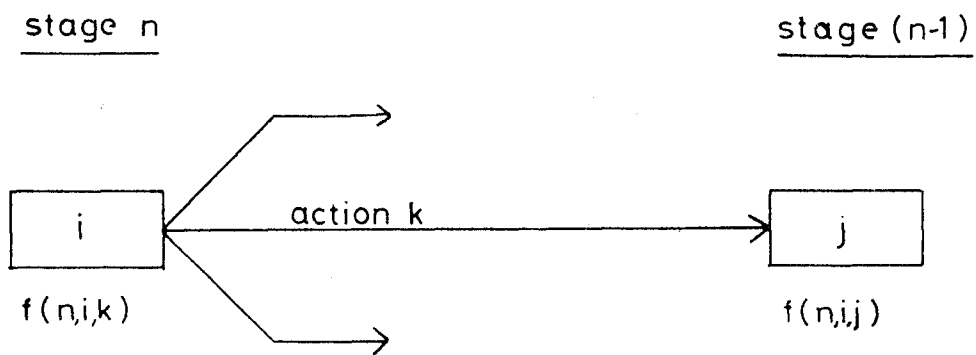

Scheme 2: Basic structure of Deterministic Dynamic Programming Problems

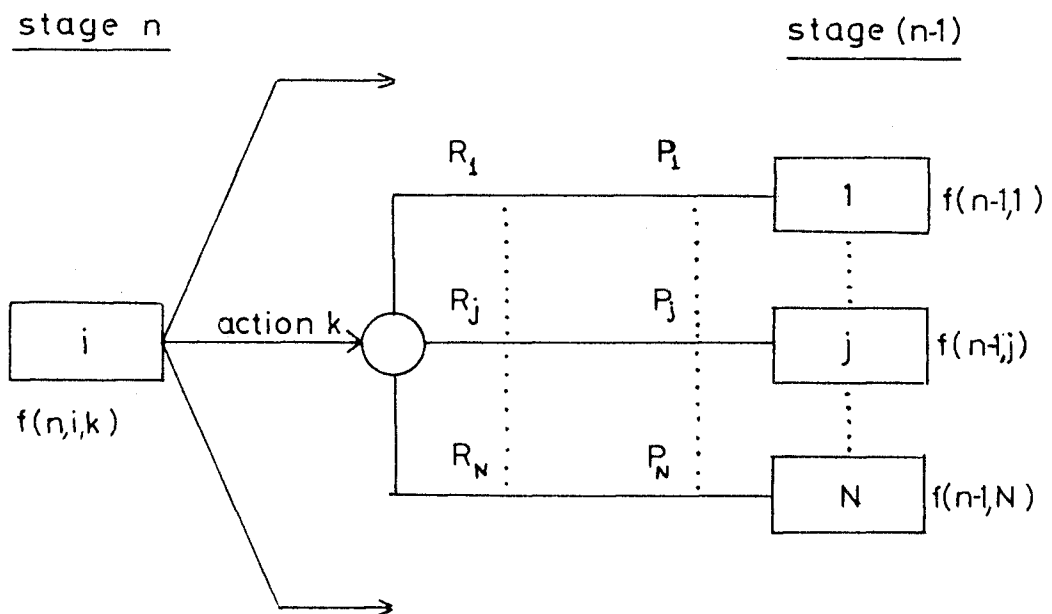

Scheme 3: Basic structure of Probabilistic Dynamic Programming Problems

(4) When the form of the distribution of the random variable involved is known, but the parameters, such as mean or variance are unknown, then we have an adaptive process.

As far as the objective function is concerned it often takes the form of the "expected value" of some function. But there are other criteria introduced as well such as "maximise the probability that the return exceeds some fixed amount", etc.

Scheme 3 illustrates type 2 mentioned previously.

3.3 Decision making through the educational system

In this section a simple mathematical model is given concerning an individual's decision making through the educational system. The individual's decisions are considered as being a multistage process in which two factors play an important role: the financial improvement due to additional education he receives and also the uncertainty associated with his decisions. The basic idea originated from the work by COMAY *et al.* (1973) (see section 2.2.1).

The main features of our model are illustrated in scheme 4 in the form of a decision tree. The precise interpretation of the various symbols will be given in the following sections. The mathematical technique used is that of Dynamic programming. A decision network covering the entire educational system is given in Appendix A, scheme 1.

3.3.1 The statement of the problem

Consider an individual within an educational system, who is to decide whether to continue his studies further or to leave the system. Assuming (a) that he is aware of the average earnings associated with each qualification offered; (b) the flows of students among the various

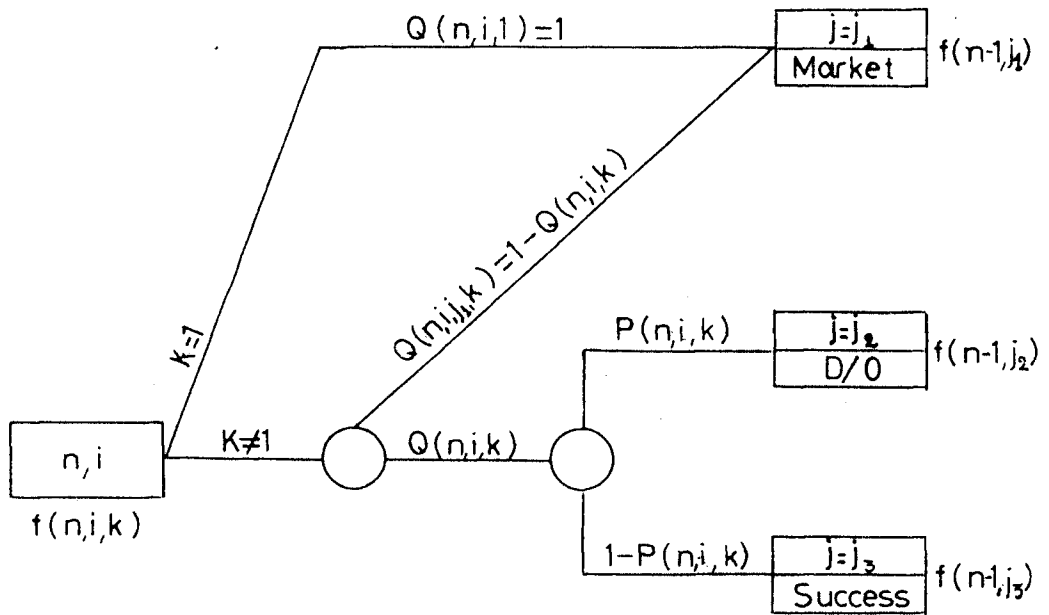

Scheme 4: Decision Tree

branches of the educational system as well as the failure rates; (c) that he can estimate broadly his own probabilities of acceptance and failure; and (d) that his only objective is the maximisation of the expected sum of net benefits generated because of additional training.

Determine (i) the sequence of decisions which yield the best earnings
(ii) the value of the total expected net earnings.

3.3.2 Formulation of the problem - terminology

First the variables used in the Dynamic programming formulation of the above problem will be defined. It is assumed that the educational system has been divided into educational levels.

Stage $\{n\}$. The stage variable n represents the number of educational levels to be considered until the end of the educational process. The successor to stage n , is denoted by m . Generally, $m = n-1$, but not always as it is shown in scheme 1, Appendix A. In this sense a stage is a step, a transition within the system. Only the postcompulsory educational system will be considered which, for the purposes of our model, has been decomposed into six stages. If $N = 6$ denoted the total number of stages then $n = 1, \dots, N$.

State $\{i\}$. The state variable is defined as the possible outcome of a transition between the educational levels. The next state to state i , which is in stage m , is denoted by j . We shall consider the possible outcomes:

$j = j_3$ meaning the "successful completion" of a transition.

$j = j_2$ meaning "not successful completion".

$j = j_1$ meaning the outcome of a transition from any state to the market state.

Action or Decision $\{k\}$. This variable is defined as a particular choice that the individual is going to make among the alternatives for which he is eligible.

In general, it is assumed that there is a set K of alternative decisions open to qualified persons at any stage n and state i .

$$\text{i.e. } K = \{k = 1, k = 2, \dots, k = r\}$$

$k = 1$ means that the individual leaves the system and goes to employment. (No account has been taken of the reverse procedure, i.e. reentry to education from employment.) The possible transitions from a general state (n, i) under action $k = 1$ or $k \neq 1$, can be interpreted as follows: Assume that a person is at some educational level (= stage n) and holds a certain qualification (= state i). If he makes a decision (= action $k \neq 1$) then at the end of the next educational level (= stage m), provided he has been accepted, he will either succeed in completing his course ($j = j_3$) or he will not ($j = j_2$). If he makes the choice $k = 1$ (= take a job) at either a successful or a D/O state then deterministically he will be in the market ($j = j_1$) at the next stage $(n-1)$.

Although the above variables can describe any transition two points should be made:

(a) The market state $j = j_1$ is an absorbing one whenever occurs and therefore transitions toward other states are not considered.

(b) When transitions are made to 'O' or 'A' level (either full time or part time), state $j = j_2$ (= "not successful completion"), does not mean a failure, but it rather means that the student in question has not been awarded the uppermost qualification granted. Thus, $j = j_2$ for 'O' level or 'A' level corresponds to < 5 'O' and ≤ 1 'A' respectively. A similar point can be made for the City and Guilds transitions. For these, $j = j_2$ (= "not successful completion") is taken to mean the qualification awarded to students after three years of studies and it does not necessarily imply a dropout of the two year course where

successful completion is denoted by $j = j_3$. For any other transition $j = j_2$ means a failure. The only available transition from $j = j_2$ (when it means a failure) is under $k = 1$, i.e. toward employment. Returns $\{r(n,i)\}$ and Costs $\{c(n,i)\}$. We assume that with any stage and state, i.e. with any (n,i) , there is associated an expected return $r(n,i)$ reflecting roughly the "price" of the awarded qualification as it is estimated in the market. This has been estimated as average lifetime earnings, taken arbitrarily to be 40* average annual earnings. The absolute values have of course changed considerably since this data was collected but the relative values may still have some reality. No discounting has been done over the lifetime period, since the individual is assumed to make a subjective estimate, and on past experience salaries rise at a fairly constant rate due to inflation. Also with each (n,i) is associated a cost $c(n,i)$, measured in terms of earnings foregone up to that stage by the individual when he continued his studies rather than entered the labor force. Direct costs, i.e. fees, have been ignored since the great majority of students have all their education costs paid by local authorities. The values for earnings and costs associated with various qualifications are given in Appendix B, Table 1.

The return of a dropout state j_2 , for which no data was available, has been taken arbitrarily as giving an advantage which is 1/3 the advantage of the corresponding successful state j_3 ;

$$\text{i.e. } r(n-1, j_2) = 1/3 \{r(n-1, j_3) - r(n, i)\} + r(n, i)$$

The dropout is always assumed to occur half way through the course, so the foregone earnings are those of the previous state augmented by 1/2 of the foregone earnings of the current successful state

$$\text{i.e. } c(n-1, j_2) = 1/2 \{c(n-1, j_3) + c(n, i)\}.$$

These assumptions have been made before in similar studies (COMAY, *et al.* 1973). Returns and costs have been discounted over the educational period, with a discounted factor :

$$b(n,i,j,k) = \frac{1}{(1+r)^t} t(n,i,j,k), \text{ all } n,i,j,k$$

where r is the discount rate taken as 8% and $t(n,i,j,k)$ is the transition time from state (n,i) to (m,j) under action k . It has been assumed that the transition time under $k = 1$ is zero.

Transition probabilities $\{p(n,i,j,k)\}$. With any action $k > 1$ there is associated a probability $Q(n,i,k)$ of being accepted as a student for the desired qualification, and a probability $P(n,i,k)$ of not successfully completing the course. Thus the possible outcomes of decision k (see scheme 4) are:

- (i) not accepted, probability $\{1 - Q(n,i,k)\}$, which is assumed to mean leaving the educational system for employment.
- (ii) accepted, but dropping out, probability $Q(n,i,k)P(n,i,k)$
- (iii) accepted and successful, probability $Q(n,i,k)\{1-P(n,i,k)\}$.

Each of these outcomes leads to a different successor state (m,j) . Thus, e.g. from state $(3,7)$, successful completion of OND, under action $k = 2$, attempt HND, the possible successor states are $(2,14)$ (= employment as qualified OND), $(2,11)$ (= dropout from HND course) or $(2,10)$ (= successful completion of HND).

Any individual can assess his own probabilities $Q(n,i,k)$ and $P(n,i,k)$. In making this assessment he will be guided by information about the proportion of people of his state and stage who actually make any decision (e.g. the proportion of 2 'A' level people accepted for university degrees, the proportion of 5 'O' level people accepted for HNC, etc.) since this will define an average $Q(n,i,k)$ and also by information about the proportion on any course who fail to complete that

course since this will define an average $P(n,i,k)$. These averages are simply used to indicate what range of Q's and P's would be reasonable. However, an individual's optimal path through the educational system will be evaluated on the basis of his own subjective probabilities. The calculation of average probabilities is given in Table 2 in Appendix B.

3.3.3 Recurrence relationship

The aim of the individual at any state and stage in the educational system is assumed to be to maximise his expected total benefits from the educational process. If $f(n,i,k)$ is the maximum expected lifetime income less incurred costs for an individual at state (n,i) under action k , and $f(n,i)$ his best expected income less cost, over all k , then by the principle of optimality we may write

$$f(n,i,k) = \sum_j p(n,i,j,k) f(\overset{m}{\cancel{n}},j)$$

where $p(n,i,j,k)$ is the transition probability from (n,i) to (m, j) under action k , calculated as previously described and the summation is over those j accessible from (n,i) under action k .

These quantities may now be expressed in terms of those previously given. At (n,i) the lifetime earnings are estimated as $r(n,i)$ and the costs to date, i.e. the earnings foregone, are $c(n,i)$. Thus the advantage of attaining state $(n-1,j)$ is $f(n-1,j) - r(n,i) + c(n,i)$ discounted over the time taken to attain this state. Hence,

$$f(n,i,k) = r(n,i) - c(n,i) + \sum_j p(n,i,j,k) b(n,i,j,k) \left\{ f(n-1,j) - r(n,i) + c(n,i) \right\} \quad (1)$$

$$\text{and } f(n,i,1) = r(n,i) - c(n,i) \quad (2)$$

$$\text{and } f(n,i) = \max_{\text{all } k} f(n,i,k) \quad (3)$$

The process terminates in market states from which there are no actions, i.e. in absorbing states. For any such state it follows automatically that

$$f(n,i) = r(n,i) - c(n,i) \quad (4)$$

From (1), (2), (3), (4) the values of $f(n,i)$ for all nodes may be calculated terminating in the value of $f(6,1)$ which is the best expected lifetime income less cost for a school leaver based on taking what is the best route for him through the educational system. The recurrence relationship begins with

$$f(0,1) = r(0,1) - c(0,1)$$

$$f(0,2) = r(0,2) - c(0,2)$$

the assigned lifetime earnings less costs for a successful and a dropout respectively. Then

$$f(1,6) = f(1,6,1) = f(0,1)$$

$$\text{and } f(1,7) = f(1,7,1) = f(0,2)$$

since there is only one $k = 1$ from each of these states.

Further, since (1,5) is a market state

$$f(1,5) = r(1,5) - c(1,5)$$

and $f(2,6,1) = f(1,5)$ is the return under action $k = 1$

$$\begin{aligned} \text{while } f(2,6,2) = & r(2,6) - c(2,6) + b(2,6,7,2) p(2,6,7,2) \left\{ f(1,7) - r(2,6) + c(2,6) \right\} \\ & + b(2,6,6,2) p(2,6,6,2) \left\{ f(1,6) - r(2,6) + c(2,6) \right\} \end{aligned}$$

is the expected return under action $k = 2$ (= continue postgraduate studies)

where $p(2,6,7,2)$ is the probability of dropping out of the postgraduate course, $p(2,6,6,2)$ is the probability of successful completion of the postgraduate course, $b(2,6,7,2)$ and $b(2,6,6,2)$ are the discount factors corresponding to states (1,7) and (1,6) respectively, $f(1,7)$ and $f(1,6)$ are the best expected benefits less costs for a dropout and successful postgraduate respectively. In terms of Q and P defined earlier

$$p(2,6,7,2) = P(2,6,2) Q(2,6,2)$$

$$\text{and } p(2,6,6,2) = \left\{ 1 - P(2,6,2) \right\} Q(2,6,2)$$

3.4 Numerical application

The general model described in the previous section, will be illustrated by means of British data. The British system of post-compulsory education is now changing but the system described is that which obtained in 1972, since it is for that period that statistics were available.

3.4.1 Grouping the transitions

There are 79 different actions in total and therefore 79 different transitions covering the entire system. Since the aim was to investigate the effect of changes in P and Q , this number of transitions could not be treated and they have been grouped into eight sets:

- Set A: It covers transitions from school leavers to 'O' level
- B: It covers transitions from school leavers to ONC, C & G
- C: It covers transitions from 'O' level to 'A' level
- D: It covers transitions from 'O' level to OND, C & G, etc.
- E: It covers transitions from 'A' level to Degree
- F: It covers transitions from 'A' level to Teaching qualification
- G: It covers transitions from 'A' level to HND, CNNA degree
- H: It covers transitions from Degree to Postgraduate studies

The detailed list with all possible transitions is given in Table 3, Appendix B.

3.4.2 Upper-lower subjective probabilities

The program was run to find the optimal paths for 256 individuals whose Q 's and P 's were chosen to be in some sense representative of the population; representative in the sense that their average overall is the population average. (A similar idea was used in the paper by CAMAY *et al.* 1973 but they assumed that all Q were 1.0 and all P 's

were uniformly distributed in the interval (0,1)). Here there are known the average probabilities for the population; it is possible then to define arbitrarily a lower and upper probability whose mean is the average and which lie entirely within the range (0,1) . The subjective probabilities used are defined as:

Q_u = An individual's acceptance probability, for given n, i, k , when he anticipates that his own acceptance probability is higher than the corresponding average one Q

Q_ℓ = An individual's acceptance probability, for given n, i, k , when he anticipates that his own acceptance probability is lower than the corresponding average Q

P_u = An individual's "non successful" completion probability, for given n, i, k , when he anticipates that his own "non successful" completion probability is higher than the average P

P_ℓ = An individual's "non successful" completion probability, for given n, i, k , when he anticipates that his own "successful" completion probability is lower than the average P .

The values of Q_u , Q_ℓ , P_u , P_ℓ assigned are:

$$Q_u = 0.50 (1.0 + Q) \quad \text{if } Q \geq .5$$

$$Q_u = 0.75 Q \quad \text{if } Q < .5$$

Similarly for P_u , P_ℓ i.e.

$$P_u = 0.50 (1.0 + P) \quad \text{if } P \geq .5$$

$$P_u = 0.75 P \quad \text{if } P < .5$$

Diagrammatically the subjective probabilities are illustrated as in Scheme 5.

From the above equations Q_ℓ , P_ℓ are as follows:

$$Q_\ell = 0.50 (3Q - 1.0) \quad \text{if } Q \geq .5$$

$$Q_\ell = 0.50 Q \quad \text{if } Q < .5$$

and $P_\ell = 0.50 (3P - 1.0) \quad \text{if } P \geq .5$

$$P_\ell = 0.50 P \quad \text{if } P < .5$$

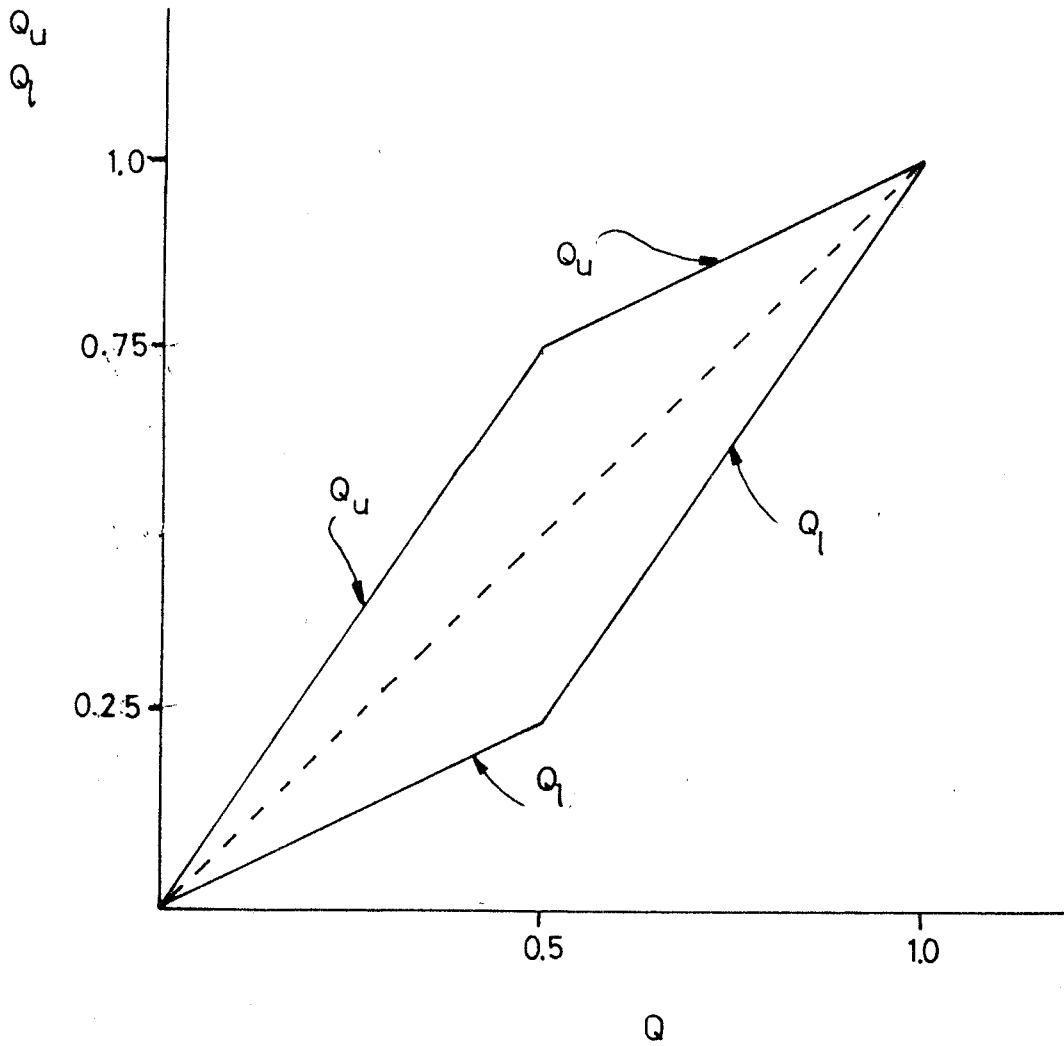

Scheme 5: Q_u and Q_l Probabilities

Each Q_u , Q_ℓ of either $\geq .5$ or $< .5$ interval can be combined with each P_u , P_ℓ of either $\geq .5$ or $< .5$ producing 16 combinations. Combinations of $Q_u P_u$ and $P_\ell Q_\ell$ type which indicate above average "acceptance" - above average "not successful" completion and below average "acceptance" - below average "not successful" completion, are excluded from further consideration as representing a rather unrealistic situation.

The following four combinations:

- | | |
|---|---|
| (a) $Q_u = 0.50(1.0 + Q)$, $Q \geq .5$ | (b) $Q_u = 0.50(1.0 + Q)$, $Q \geq .5$ |
| $P_\ell = 0.50(3P - 1.0)$, $P \geq .5$ | $P_\ell = 0.50P$, $P < .5$ |
| (c) $Q_u = 0.75Q$, $Q < .5$ | (d) $Q_u = 0.75Q$, $Q \geq .5$ |
| $P_\ell = 0.50(3P - 1.0)$, $P \geq .5$ | $P_\ell = 0.50P$, $P < .5$ |

give all definitions of Q_u , P_ℓ which describe an individual's personal assessment when he estimates his own "acceptance" probability is higher than the average one and his "non successful" completion probability is lower than the average one. These constitute an upper (or type 1) assignment. In the computer program the upper assignment is given by the UPPER subroutine.

The remaining four combinations

- | | |
|---|---|
| (e) $Q_\ell = 0.50(3Q - 1.0)$, $Q \geq .5$ | (f) $Q_\ell = 0.50(3Q - 1.0)$, $Q \geq .5$ |
| $P_u = 0.50(1.0 + P)$, $P \geq .5$ | $P_u = 0.75P$, $P < .5$ |
| (g) $Q_\ell = 0.50Q$, $Q < .5$ | (h) $Q_\ell = 0.50Q$, $Q < .5$ |
| $P_u = 0.50(1.0 + P)$, $P \geq .5$ | $P_u = 0.75P$, $P < .5$ |

are referred to as the lower (= type 2) assignment, where an individual considers that he has an "acceptance" probability below the average and a "non successful" completion probability above the average. In the computer program the subroutine LOWER deals with this situation. By assigning the upper and lower values and employing the recurrence relation

of the previous section for all the values of stage n , state i , action k , $2^8 = 256$ different outputs are produced. Each of these outputs corresponds to one optimal path through the educational system for a student with a particular combination of upper and lower assessments. For example: A student who assesses that his chances for the groups A (= taking 'O' level), B (= taking ONC or C & G), D (= taking OND or HNC) are above average (= upper) and for the groups C (= taking 'A' level), E (= taking a Degree), F (= taking Teaching course), G (= taking CNNA or HND), H (= taking postgraduate) his chances are below average (= lower), the corresponding output will be denoted by:

A	-	transition type	1
B	-	"	" 1
C	-	"	" 2
D	-	"	" 1
E	-	"	" 2
F	-	"	" 2
G	-	"	" 2
H	-	"	" 2

3.4.3 Output of computer program

A computer program written in FORTRAN IV was developed and run for the purposes of our model (for a listing see Appendix C). Its main functions are briefly described as follows:

- (a) Given any state (n,i) , it assigns to each action associated with that state, a pair of subjective probabilities Q (= acceptance) and P (= non successful completion) through the UPPER and LOWER subroutines.
 - (b) It calculates the transition probabilities $P(2)$ and $P(3)$ from a state (n,i) to a dropout and successful state respectively.
 - (c) It calculates the value of every state (n,i) for each action k and it selects the maximum value (= optimal value).
 - (d) It determines that action which corresponds to the optimal value.
- When the above steps have been accomplished the procedure starts again examining the next stage.

THE OUTPUT: Any output starts with the appropriate headings denoting the combinations of transitions we are dealing with and there follows the main body of the output consisting of ten columns.

Column N shows the stage variable, i.e. the number of the educational stages remaining to be considered. $N = 0$ means that the end of the process is reached. $N = 1$ means that one stage is left, and so on.

Column I is referred to the state variable which indicates the outcome of any transition as far as the educational qualifications are concerned.

Column K shows the decisions (= actions) made at a particular state.

The decision to "Go to the Market" is denoted by $k = 1$. All other decisions are denoted by $k = 2, k = 3$, etc.

Column Q shows the "acceptance" probability under a particular decision.

Whenever $k = 1$, $Q(n,i,k) = 1$ since the transition from any state toward the market is certain.

Column P indicates the "non successful" completion probability associated with some action k at state (n,i) .

Columns P2, P3 show the transition probabilities of being in the dropout state and successful state respectively.

Column TRIVAL gives the value of the objective function (= trial value) under action k when the system is in state (n,i) and an optimal path is followed for the remaining stages.

Column OPT.VALUE gives the maximum value of all values in column TRIVAL.

Column BEST K gives the action corresponding to the optimal values.

As an illustration, a typical part of output of the $A = 1, B = 2, C = 1, D = 1, E = 2, F = 2, G = 1, H = 1$ transition is given in Table 1. The first five lines give $f(n,i,k)$ for $k = 1,2,3,4,5$.

The sixth line gives the optimal value of state $(6,1)$. That is

$$f(6,1) = \max \{14,640.00; 21,373.56; 17,775.97; 15,153.79; 14,898.25\} \\ = 21,373.56, \text{ under } k = 2.$$

The complete output is given in Appendix C.

TABLE 1

A sample output of the
 $A = 1, B = 2, C = 1, D = 1, E = 2, F = 2, G = 1, H = 1$
 transitions

N	I	K	Q	P	P_2	P_3	TRIVAL	OPT.VALUE	BEST	K
6	1	1	1.0000				14,640.00			
6	1	2	0.8046	0.1933	0.1556	0.6491	21,373.56			
6	1	3	0.1550	0.7867	0.1219	0.0331	17,775.97			
6	1	4	0.0217	0.3213	0.0070	0.0147	15,153.79			
6	1	5	0.0232	0.2000	0.0046	0.0186	14,898.25			
6	1							21,373.56		2

3.4.4 How the optimal path is obtained

By entering the output at the final state, the optimal action corresponding to the optimal value is determined, i.e. in the output shown in Appendix C action $k = 2$ is the optimal one since it corresponds to the optimal value $f(6,1) = 21,373.56$. From the decision network (shown in Appendix A) the successor states, under the above optimal action, are found, i.e. $(5,1)$ or $(5,2)$. The optimal actions corresponding to these states can now be determined by re-entering the output at the respective entries, i.e. the optimal action for state $(5,1)$ is $k = 5$ and for $(5,2)$ is $k = 2$. The above procedure is repeated until a market state is reached. The sequence of all optimal actions found constitutes an optimal path. The optimal path for the transition in question is shown in scheme 6.

3.5 Summary and analysis of the results

The program produced 256 outputs. An analysis of these outputs indicated that the various combinations of the transitions could be grouped into 23 sets according to the final optimal values. Table 2 shows the optimal value of the final state $(6,1)$, the conditions under which it occurs, the optimal action and the number of combinations sharing the same optimal value.

The optimal path corresponding to set 1 (i.e. combinations of type $B = 1, \underbrace{A, C, D, E, F, G, H}_{= 1 \text{ or } 2}$) is shown in scheme 7. It is also clear from Table 2 that the $B = 1$ transition (i.e. school leavers to C & G) is a very important one; all individuals who have greater than average ability in the transition from school to technical training have an optimal total return of 24,428.89 whatever their capabilities elsewhere.

Those with lower than average probability (i.e. $B=2$) at the same transition may have any one of the remaining total returns (from 22,826.12 to 17,775.97) depending upon the values of A,C,D,E,F,G,H transitions.

The optimal path confirms the importance of B transitions indicating that the best action is $k = 3$ (i.e. take C & G), followed by taking a job, as a technician, whether the course has been completed in two or in three years.

A further analysis of Table 2 reveals that when a student considers himself as belonging to the $A = 1, B = 2$ transitions, i.e. above average for '0' level, below average for technical training (sets 2-19), then his best choice would be to take '0' level ($k = 2$). From this point onwards his next choice would depend upon his future assessments with varying optimal values and optimal paths associated with them.

For example consider

Set 3: $A = 1, B = 2, D = 1, E = 1, F = 1, G = 1, H = 1, \underbrace{C}_{= 1 \text{ or } 2}$ and

Set 4: $A = 1, B = 2, D = 1, E = 1, F = 1, G = 2, H = 1, \underbrace{C}_{= 1 \text{ or } 2}$

differing on the G transition only, with $f(6,1) = 22,758.9$ and

$f(6,1) = 22,713.43$ respectively. The sensitivity of the optimal value, depending on G transitions, is better illustrated on schemes 6 and 8 showing the optimal paths corresponding to sets 3 and 4 respectively; that is, the difference in ability in G transition results in a deviation in the optimal action at state (4,3) giving: optimal action $k = 4$ (= continue to Art and Design course), when $G = 1$ (set 3) and optimal action $k = 3$ (= continue to teaching training course), when $G = 2$ (set 4).

A similar comparison among

Set 20: $A = 2, B = 2, D = 1, E = 1, F = 1, H = 1, \underbrace{C, G}_{= 1 \text{ or } 2}$

Set 21: $A = 2, B = 2, D = 1, E = 1, F = 2, G = 1, H = 1, \underbrace{C}_{= 1 \text{ or } 2}$

$$\text{Set 22: } \begin{matrix} A = 2 \\ B = 2 \end{matrix}, D = 1, E = 1, F = 2, G = 2, H = 1, \underbrace{C}_{= 1 \text{ or } 2}$$

indicate that when a student assesses his own abilities in both transitions A and B as below average ($A = 2, B = 2$) then his best choice at the final state (6,1) is to take '0' levels ($k = 2$), as in the transitions discussed above. A comparison of sets 21 and 22 shows once more that transition G is the important one, generating difference in the optimal values and in the associated optimal paths (schemes 6 and 8). On the other hand, a comparison between sets 20 and 21 or 22 reveals that the difference in the optimal values and optimal paths is attributed not to a single transition but to both transitions F and G.

Finally, set 23 consists of two distinct transitions, either

$$\begin{matrix} A = 2 \\ B = 2 \end{matrix}, \text{ not } D = E = H = 1, \underbrace{C, F, G}_{= 1 \text{ or } 2}$$

i.e. a student "poor" at the early stages and not sufficiently good in the intermediate ones, or

$$\begin{matrix} A = 1 \\ B = 2 \end{matrix}, D = 2, E = 2, \underbrace{C, F, G, H}_{= 1 \text{ or } 2}$$

i.e. students good in taking '0' levels but below average in D and E transitions. These two transitions of set 23 share a common optimal path (scheme 7). The same optimal path G applies to set 1 ($B = 1$), although there is a considerable difference in the optimal values:

$$\text{Set 23: } f(6,1) = 17,775.97$$

$$\text{Set 1: } f(6,1) = 24,428.89 .$$

3.5.1 Second best

In a further analysis of the results interest was focused on four particular combinations of the type

$$(a) \begin{matrix} A = 1 \\ B = 1 \end{matrix}, \underbrace{C, D, E, F, G, H}_{= 1}$$

$$(b) \begin{matrix} A = 2 \\ B = 1 \end{matrix}, \underbrace{C, D, E, F, G, H}_{= 2}$$

$$(c) \begin{matrix} A = 1 \\ B = 2 \end{matrix}, C=1, D=2, E=2, F=1, G=1, H=1 \quad (d) \begin{matrix} A=2 \\ B=2 \end{matrix}, \frac{C,D,E,F,G,H}{= 2}$$

(a) and (b) transitions represent the extreme combinations of set (1). (c) and (d) the extremes of set 23. For each of them the non market second best value at state (6,1) was examined. Table 3 shows the second best values of the above combinations.

In all these cases the second best value corresponds to an initial decision $k = 2$, i.e. take '0' level. The margin between best and second best in cases (a) and (c) is quite small, and in case (b) $k = 4$ gives nearly the same result as $k = 2$.

It was shown in the previous section that combinations (a), (b), (c), and (d) showed a common optimal path (scheme 7). In the case of the second best values a common optimal path also exists, different from the previous one (scheme 8). It is because (b) and (d) share the same second best path, not including a B-transition, that their second best value is the same since all their other transitions are of the same type. This path is more complicated than the previous one, including '0' level course rather than C & G and subsequent various possibilities up to the postgraduate level. However, the second best expected benefits are outweighed by the expected benefits of the technical routes. Therefore given the probabilities, it would be necessary to increase the state returns or decrease the costs on time in order that routes which include '0' and 'A' level and Degree courses could compete with the technical ones. For instance from Table 2 it is clear that in order to change the route from $k = 3$ to $k = 2$ of a student belonging to the $\begin{matrix} A=1 \\ B=1 \end{matrix}, \frac{C,D,E,F,G,H}{= 1}$ transition a subsidy of $24,425.59 - 22,362.12 = 1,566.47$ would be needed, whereas in order to achieve the same change (i.e. from C & G to '0' level) for a person belonging to $\begin{matrix} A=2 \\ B=1 \end{matrix}, \frac{C,D,E,F,G,H}{= 2}$ a subsidy of $24,428.59 - 16,156.37 = 8,272.22$ would be needed.

TABLE 2
Summary of the results

No. of Sets	Optimal value at state (6,1)	Conditions under which it occurs	Optimal first action	No. of combinations
1	$f(6,1) = 24,428.89$	$B=1, \underbrace{A, C, D, E, F, G, H}_{= 1 \text{ or } 2}$	$k=3$ (= Take C & G)	128
2	$f(6,1) = 22,862.12$	$A=1$ $B=2, D=1, E=1, F=1, H=1, \underbrace{C, G}_{= 1 \text{ or } 2}$	$k=2$ (2 Take '0')	4
3	$f(6,1) = 22,758.19$	$A=1$ $B=2, D=1, E=1, F=2, G=1, H=1, \underbrace{C}_{= 1 \text{ or } 2}$	$k=2$ (Take '0')	2
4	$f(6,1) = 22,713.43$	$A=1$ $B=2, D=1, E=1, F=2, G=2, H=1, \underbrace{C}_{= 1 \text{ or } 2}$	$k=2$ (Take '0')	2
5	$f(6,1) = 22,632.12$	$A=1$ $B=2, D=1, E=1, F=1, H=2, \underbrace{C, G}_{= 1 \text{ or } 2}$	$k=2$ (Take '0')	4
6	$f(6,1) = 22,528.18$	$A=1$ $B=2, D=1, E=1, F=2, G=1, H=2, \underbrace{C}_{= 1 \text{ or } 2}$	$k=2$ (Take '0')	2
7	$f(6,1) = 22,483.43$	$A=1$ $B=2, D=1, E=1, F=2, G=2, H=2, \underbrace{C}_{= 1 \text{ or } 2}$	$k=2$ (Take '0')	2
8	$f(6,1) = 21,477.49$	$A=1$ $B=2, D=1, E=2, F=1, H=1, \underbrace{C, G}_{= 1 \text{ or } 2}$	$k=2$ (=Take '0')	4

(cont.)

TABLE 2

Summary of the results
(cont.)

No. of Sets	Optimal value at state (6,1)	Conditions under which it occurs	Optimal first action	No. of combinations
9	$f(6,1) = 21,412.18$	$A=1$ $B=2$, $D=1$, $E=2$, $F=1$, $H=2$, $\underbrace{C, G}_{=1 \text{ or } 2}$	$k=2$ (=Take '0')	4
10	$f(6,1) = 21,373.56$	$A=1$ $B=2$, $D=1$, $E=2$, $F=2$, $G=1$, $H=1$, $\underbrace{C}_{=1 \text{ or } 2}$	$k=2$ (=Take '0')	2
11	$f(6,1) = 21,328.80$	$A=1$ $B=2$, $D=1$, $E=2$, $F=2$, $G=2$, $H=1$, $\underbrace{C}_{=1 \text{ or } 2}$	$k=2$ (=Take '0')	2
12	$f(6,1) = 21,308.25$	$A=1$ $B=2$, $D=1$, $E=2$, $F=2$, $G=1$, $H=2$, $\underbrace{C}_{=1 \text{ or } 2}$	$k=2$ (=Take '0')	2
13	$f(6,1) = 21,263.49$	$A=1$ $B=2$, $D=1$, $E=2$, $F=2$, $G=2$, $H=2$, $\underbrace{C}_{=1 \text{ or } 2}$	$k=2$ (=Take '0')	2
14	$f(6,1) = 19,003.34$	$A=1$ $B=2$, $D=2$, $E=1$, $F=1$, $H=1$, $\underbrace{C, G}_{=1 \text{ or } 2}$	$k=2$ (=Take '0')	4
15	$f(6,1) = 18,899.41$	$A=1$ $B=2$, $D=2$, $E=1$, $F=2$, $G=1$, $H=1$, $\underbrace{C}_{=1 \text{ or } 2}$	$k=2$ (=Take '0')	2
16	$f(6,1) = 18,854.65$	$A=1$ $B=2$, $D=2$, $E=1$, $F=2$, $G=2$, $H=1$, $\underbrace{C}_{=1 \text{ or } 2}$	$k=2$ (=Take '0')	2
17	$f(6,1) = 18,773.34$	$A=1$ $B=2$, $D=2$, $E=1$, $F=1$, $H=2$, $\underbrace{C, G}_{=1 \text{ or } 2}$	$k=2$ (=Take '0')	4
				(cont.)

(cont.)					
18	$f(6,1) = 18,669.41$	A=1, D=2, E=1, F=2, G=1, H=2, $\overbrace{C} = 1$ or 2 B=2	k=2 (=Take '0')	2	
19	$f(6,1) = 18,624.64$	A=1, D=2, E=1, F=2, G=2, H=2, $\overbrace{C} = 1$ or 2 B=2	k=2 (=Take '0')	2	
20	$f(6,1) = 17,906.73$	A=2, D=1, E=1, F=1, H=1, $\overbrace{C,G} = 1$ or 2 B=2	k=2 (=Take '0')	4	
21	$f(6,1) = 17,826.53$	A=2, D=1, E=1, F=2, G=1, H=1, $\overbrace{C} = 1$ or 2 B=2	k=2 (=Take '0')	2	
22	$f(6,1) = 17,791.99$	A=2, D=1, E=1, F=2, G=2, H=1, $\overbrace{C} = 1$ or 2 B=2	k=2 (=Take '0')	2	
23	$f(6,1) = 17,775.97$	A=2, <u>not</u> D = E = H = 1, $\overbrace{C,F,G} = 1$ or 2 B=2 or D=2, E=2, $\overbrace{C,F,G,H} = 1$ or 2	k=3 (=Take C & G)	72	

Scheme 6: Optimal path (shown by the red lines) of the transitions:

A=1
B=2, C=1, D=1, E=2, F=2, G=1, H=1

A=1
B=2, D=1, E=1, F=2, G=1, H=1, $\overbrace{\quad\quad\quad}^C$ (set 3)
= 1 or 2

A=2
B=2, D=1, E=1, F=2, G=1, H=1, $\overbrace{\quad\quad\quad}^C$ (set 21)
= 1 or 2

Scheme 6

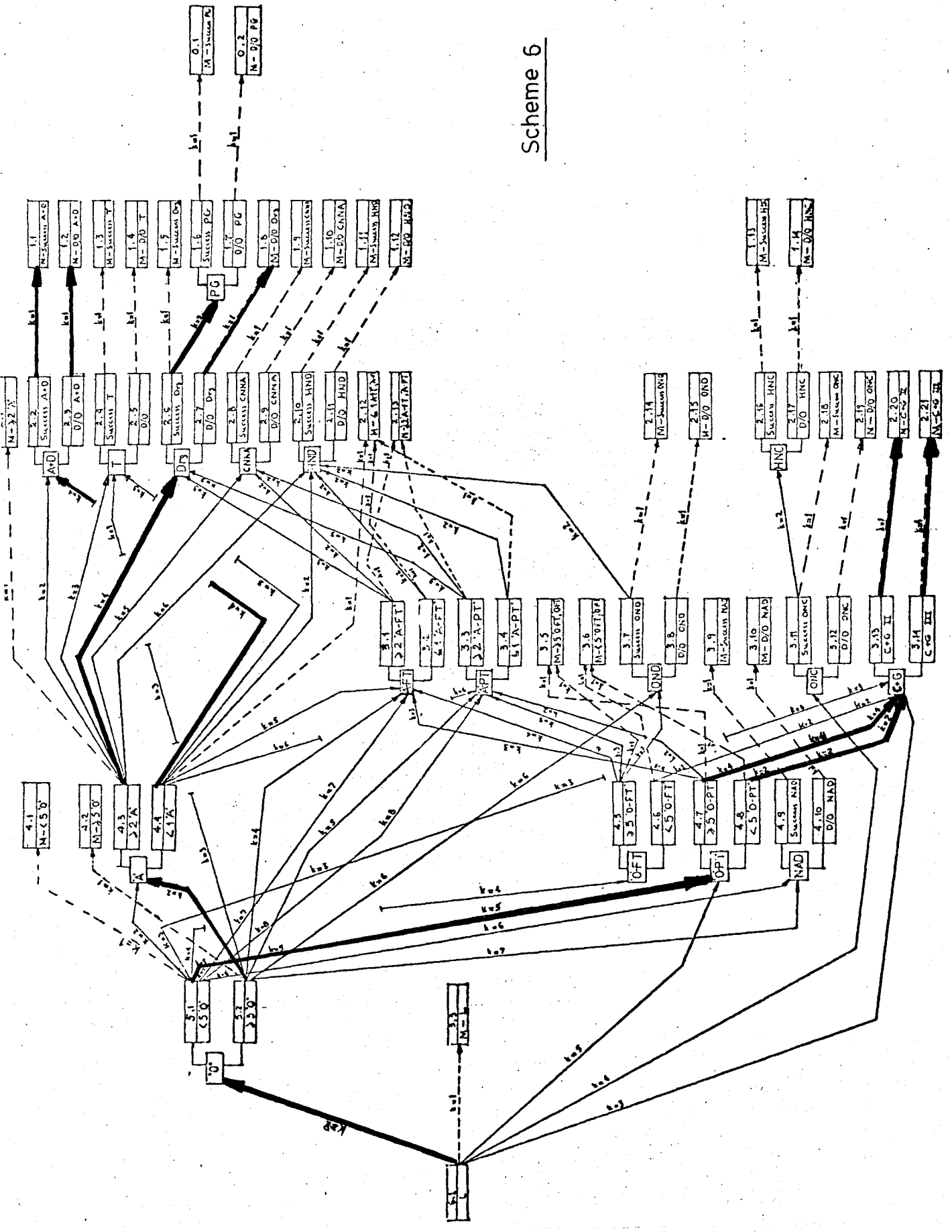

Scheme 7: Optimal path (shown by the red lines) of the transitions:

$$B=1, \underbrace{A, C, D, E, F, G, H}_{= 1 \text{ or } 2} \quad (\text{set } 1)$$

$$\left. \begin{array}{l} A=2 \\ B=2, \text{ not } D = E = F = H = 1, \underbrace{C, G}_{= 1 \text{ or } 2} \\ \text{or} \\ A=1 \\ B=2, \quad D=2, E=2 \quad \underbrace{C, F, G, H}_{= 1 \text{ or } 2} \end{array} \right\} (\text{set } 23)$$

Scheme 7

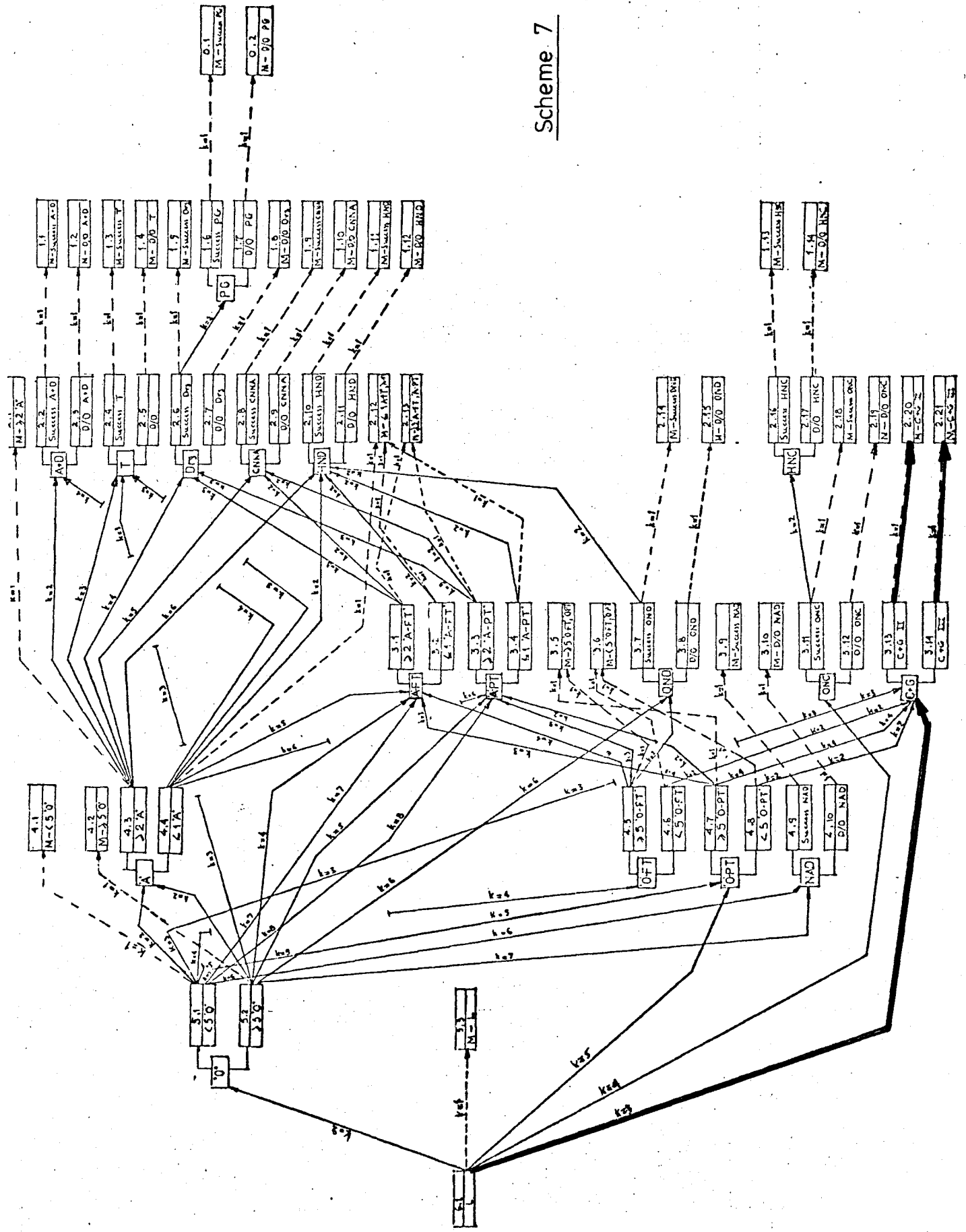

Scheme 8: Optimal path (shown by the red lines) of the transitions:

$$\begin{array}{l} A=1 \\ B=2 \end{array}, D=1, E=1, F=2, G=2, H=1, \underbrace{\quad C \quad}_{1 \text{ or } 2} \quad (\text{set } 4)$$

$$\begin{array}{l} A=2 \\ B=2 \end{array}, D=1, E=1, F=2, G=2, H=1, \underbrace{\quad C \quad}_{= 1 \text{ or } 2} \quad (\text{set } 22)$$

Scheme 8

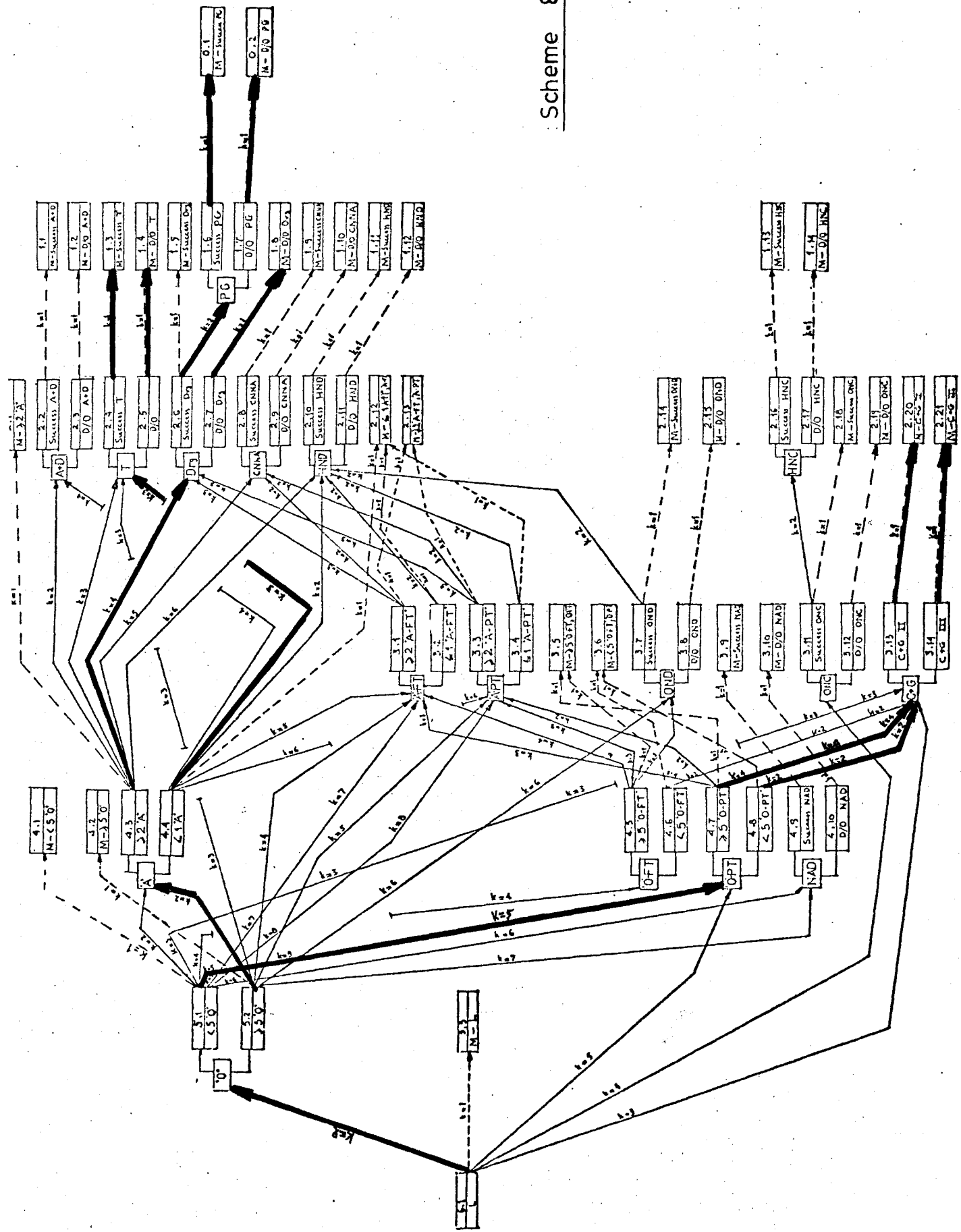

path for any individual through the British educational system. This path is dependent on the individual's own estimate of his P's and Q's and also on the state of the market in salaries payable for levels of educational attainment. Though the transitions here have been drastically grouped, the model is of course applicable without such grouping so that any desired level of detail could be incorporated. Further any change in educational structure could be included by simply redrawing the network (thus the raising of the school leaving age and the changes in Teacher training have already made the network illustrated out of date). The model then gives for any individual his own cost-benefit assessment of non compulsory education.

(b) As mentioned in section 3.5.2, the complete set of results for a number of individuals representative of the whole population can be used to aggregate demand and thus to estimate what educational facilities are going to be needed. In this sense the model gives a realisation of the Social demand approach.

(c) The effect of any change in relative salary structure could be found directly by rerunning the program and reassessing social demand. Hence it would be possible to connect any desired pattern of social demand fulfilling given manpower requirements with some range of salary structure.

(d) The model could thus be used as an aid to decision making on three levels: (i) by the individual, (ii) by the provider of educational facilities, (iii) nationally, in assessing the changes in salary structure required to produce desirable changes in the stock of qualified manpower.

APPENDIX A

- Abbreviations
- Decision network

ABBREVIATIONS

L	=	School leavers
'O'	=	'O' levels at school
'A'	=	'A' levels at school
'O'-FT	=	Full time 'O' levels in Further Education
'O'-PT	=	Part time 'O' levels in Further Education
'A'-FT	=	Full time 'A' levels in Further Education
'A'-PT	=	Part time 'A' levels in Further Education
NAD	=	Non advanced Courses in Further Education
OND	=	Ordinary National Diploma
ONC	=	Ordinary National Certificate
C & G	=	Technical qualifications awarded by City and Guilds
C & G II	=	Two year Course of City and Guilds
C & G III	=	Three year Course of City and Guilds
A & D	=	Diploma in Art and Design
T	=	Teaching Training
Dgr	=	University Degree
CNNA	=	CNNA Degree
HND	=	Higher National Diploma
HNC	=	Higher National Certificate
PG	=	Postgraduate studies
M	=	Market
D/O	=	Dropout
Success	=	Successful Completion
M-success ...	=	In Market after successful completion of ... (e.g. M-success HND = In Market after successful completion of HND.)
M-D/O ...	=	In Market after Dropout from ...

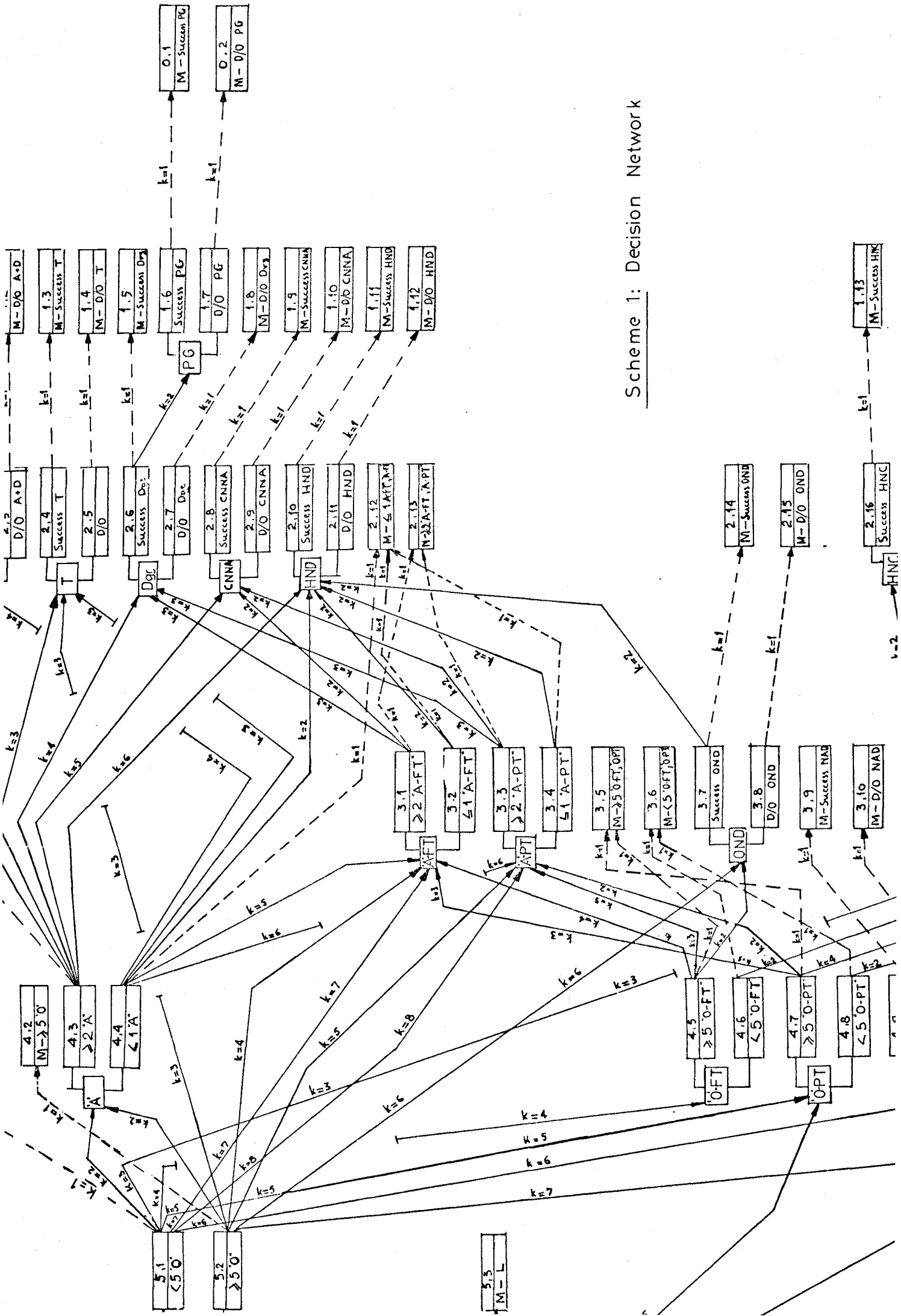

Scheme 1: Decision Network

APPENDIX B

- Transition Probabilities
- Costs and Returns
- Grouping of Transitions

TABLE 1

State Returns and Costs

State	State Returns	State Costs
Success PG	40 x 2,500	7,021
D/O PG	40 x 2,100	5,121
Success A & D	40 x 1,200	2,044
D/O A & D	40 x 818	1,730
Success T	40 x 1,500	3,221
D/O T	40 x 918	2,318
Success Dgr	40 x 1,900	3,221
D/O Dgr	40 x 1,054	2,318
Success CNNA	40 x 1,900	3,221
D/O CNNA	40 x 1,054	2,318
Success HND	40 x 1,900	3,221
D/O HND	40 x 1,054	2,318
Success HNC	40 x 1,590	415
D/O HNC	40 x 1,103	286
≥ 2 'A' - FT	40 x 628	1,416
≤ 1 'A' - FT	40 x 628	1,416
≥ 2 'A' - PT	40 x 628	649
≤ 1 'A' - PT	40 x 628	649
≥ 2 'A'	40 x 628	1,416
≤ 1 'A'	40 x 628	1,416
≥ 5 'O' - FT	40 x 525	732
≤ 5 'O' - FT	40 x 366	732
≥ 5 'O' - PT	40 x 525	523
≤ 5 'O' - PT	40 x 366	523
≥ 5 'O'	40 x 525	366
≤ 5 'O'	40 x 366	366
Success OND	40 x 860	1,416
D/O OND	40 x 635	891
Success ONC	40 x 860	157
D/O ONC	40 x 637	78
C & G II	40 x 1,000	523
C & G III	40 x 1,000	236
Success NAD	40 x 1,100	891
D/O NAD	40 x 717	628
L	40 x 366	0

(1) The returns and costs of the market states are taken to be the same as the returns and costs of the states to which they correspond (e.g. return of success Dgr = return of M-success Dgr, and cost of success Dgr = cost of M-success Dgr). For a few states the costs (i.e. foregone earnings in getting to that state) may not be uniquely determined since it can be arrived at in different ways, e.g. ≤ 1 'A'-PT, ≤ 1 'A'. In this case, to avoid introducing transitional costs, the assigned cost has been taken as the average of costs incurred by each route.

(2) The figures of state returns and costs have been taken from SURVEY of EARNINGS of QUALIFIED MANPOWER IN 1966 (1971) and MORRIS (1973). For the D/O states for which data were not available estimates have been made.

TABLE 2

Average probabilities of acceptance and of non successful completion

From	To	Acceptance Probab. Q (*)	Non successful completion probab. P (*)
Success Dgr	M-success Dgr	0.6000	-
Success Dgr	PG	0.4000	0.3500
≥ 2 'A' - FT	M- ≥ 2 'A' - FT	0.1250	-
≥ 2 'A' - FT	CNNA	0.2500	0.2727
≥ 2 'A' - FT	Dgr	0.6250	0.1379
≤ 1 'A' - FT	M- ≤ 1 'A' - FT	0.8750	-
≤ 1 'A' - FT	HND	0.1250	0.2500
≥ 2 'A' - PT	M- ≥ 2 'A' - PT	0.3333	-
≥ 2 'A' - PT	CNNA	0.3333	0.2727
≥ 2 'A' - PT	Dgr	0.3333	0.1379
≤ 1 'A' - PT	M- ≤ 1 'A' - PT	0.9772	-
≤ 1 'A' - PT	HND	0.0227	0.2500
Success OND	M-success OND	0.6666	-
Success OND	HND	0.3333	0.2500
Success ONC	M-success ONC	0.0909	-
Success ONC	HNC	0.9090	0.3000
≥ 2 'A'	M- ≥ 2 'A'	0.2317	-
≥ 2 'A'	A & D	0.0975	0.2307
≥ 2 'A'	T	0.1219	0.0500
≥ 2 'A'	Dgr	0.4512	0.1379
≥ 2 'A'	CNNA	0.0731	0.2727
≥ 2 'A'	HND	0.0243	0.2500
≤ 1 'A'	M- ≤ 1 'A'	0.5641	-
≤ 1 'A'	HND	0.0256	0.2500
≤ 1 'A'	T	0.1794	0.0500
≤ 1 'A'	A & D	0.1282	0.2307
≤ 1 'A'	'A' - FT	0.0256	0.6666
≤ 1 'A'	'A' - PT	0.0769	0.9361
≥ 5 'O' - FT	M- ≥ 5 'O' - FT	0.2083	-
≥ 5 'O' - FT	OND	0.3750	0.4545
≥ 5 'O' - FT	'A' - PT	0.1250	0.9361
≥ 5 'O' - FT	'A' - FT	0.2916	0.6666

(cont.)

TABLE 2
(cont.)

From	To	Acceptance Probab. Q (*)	Non successful completion probab. P (*)
≤ 5 'O' - FT	M-≤ 5 'O' - FT	0,5000	-
≤ 5 'O' - FT	C & G	0.5000	0.5734
≥ 5 'O' - PT	M-≥ 5 'O' - PT	0.3333	-
≥ 5 'O' - PT	'A' - PT	0.2777	0.9361
≥ 5 'O' - PT	'A' - FT	0.1111	0.6666
≥ 5 'O' - PT	C & G	0.2777	0.5734
≤ 5 'O' - PT	M-≤ 5 'O' - PT	0.3125	-
≤ 5 'O' - PT	C & G	0.6875	0.5734
≤ 5 'O'	M-≤ 5 'O'	0.0746	-
≤ 5 'O'	'A'	0.0207	0.3223
≤ 5 'O'	C & G	0.1244	0.5734
≤ 5 'O'	'O' - FT	0.1244	0.2000
≤ 5 'O'	'O' - PT	0.4688	0.4000
≤ 5 'O'	NAD	0.1327	0.2500
≤ 5 'O'	'A' - FT	0.0125	0.6666
≤ 5 'O'	'A' - PT	0.0414	0.9361
≥ 5 'O'	M-≥ 5 'O'	0.0460	-
≥ 5 'O'	'A'	0.7631	0.3223
≥ 5 'O'	T	0.0197	0.0500
≥ 5 'O'	'A' - FT	0.0328	0.6666
≥ 5 'O'	'A' - PT	0.0723	0.9361
≥ 5 'O'	OND	0.0131	0.4545
≥ 5 'O'	NAD	0.0526	0.2500
L	M-L	0.0217	-
L	'O'	0.6093	0.3867
L	C & G	0.3100	0.5734
L	ONC	0.0434	0.2142
L	'O' - PT	0.0155	0.4000

(*) SOURCE: EDUCATIONAL STATISTICS (1972)

TABLE 3

Grouping of the state transitions

Group	State transitions	
	From	To
A	L L	'O' 'O' - PT
B	L L	ONC C & G
C	≤ 5 'O' ≤ 5 'O' ≤ 5 'O' ≥ 5 'O' ≥ 5 'O' ≥ 5 'O' ≥ 5 'O' - FT ≥ 5 'O' - FT ≥ 5 'O' - PT ≥ 5 'O' - PT	'A' 'A' - FT 'A' - PT 'A' 'A' - FT 'A' - PT 'A' - FT 'A' - PT 'A' - FT 'A' - PT
D	ONC ≤ 5 'O' ≤ 5 'O' ≤ 5 'O' ≤ 5 'O' ≥ 5 'O' ≥ 5 'O' ≥ 5 'O' - FT ≥ 5 'O' - PT ≤ 5 'O' - PT ≤ 5 'O' - FT	HNC C & G 'O' - FT 'O' - PT NAD OND NAD OND C & G C & G C & G
E	≥ 2 'A' ≥ 2 'A' - FT ≥ 2 'A' - PT	Dgr Dgr Dgr
F	≥ 2 'A' ≤ 1 'A' ≤ 5 'O'	T T T
G	≥ 2 'A' ≤ 1 'A' ≤ 1 'A' - FT ≤ 1 'A' - PT OND ≥ 2 'A' ≥ 2 'A' - FT ≥ 2 'A' - PT ≤ 1 'A' ≤ 1 'A' ≥ 2 'A' ≤ 1 'A'	HND HND HND HND HND CNNA CNNA CNNA 'A' - FT 'A' - PT A & D A & D
H	Dgr	PG

APPENDIX C

- Computer Program
- Computer Output

Computer Program

```

1  SSIG PANS T=2 ROUTE=CURP
2  CHARGING RATE = UNIVERSITY, BATCH
3  **LAST SIGNOR WAS: 14:17:18
4  USER "WAZP8" SIGNED CN AT 17:04:00 CN THU OCT 14/76
5  $L COSTAS
6
7  DIMENSION O(100),P(100),PI(100),P2(100),P3(100),T2(100),T3(100),
8  P2(100),P3(100),K(70),C(70)
9  DIMENSION NL(87),NR(87),NC(87),ND(87),NE(87),NF(87),NG(87),NH(87)
10  1,PA(87),QA(87)
11  RATE = C.C8
12
13  C READ IN ALL INDICES.
14  C
15  C
16  C
17  C
18  C
19  C
20  C
21  C
22  C
23  C
24  C
25  C
26  C
27  C
28  C
29  C
30  C
31  C
32  C
33  C
34  C
35  C
36  C
37  C
38  C
39  C
40  C
41  C
42  C
43  C
44  C
45  C
46  C
47  C
48  C
49  C
50  C
51  C
52  C
53  C
54  C
55  C

```

```

1  DIMENSION O(100),P(100),PI(100),P2(100),P3(100),T2(100),T3(100),
2  P2(100),P3(100),K(70),C(70)
3  DIMENSION NL(87),NR(87),NC(87),ND(87),NE(87),NF(87),NG(87),NH(87)
4  1,PA(87),QA(87)
5  RATE = C.C8
6
7  C READ IN ALL INDICES.
8  C
9  C
10  C
11  C
12  C
13  C
14  C
15  C
16  C
17  C
18  C
19  C
20  C
21  C
22  C
23  C
24  C
25  C
26  C
27  C
28  C
29  C
30  C
31  C
32  C
33  C
34  C
35  C
36  C
37  C
38  C
39  C
40  C
41  C
42  C
43  C
44  C
45  C
46  C
47  C
48  C
49  C
50  C
51  C
52  C
53  C
54  C
55  C

```

```

1  READ(9,95) INO1,INO2,MO,STAG,NOST1,NOST2,NACT1,NOST3,NACT2,
2  NACT3,NACT4,NACT5,NACT6,NACT7,NOST4,NACT8,NACT9,NACT10,
3  NACT11,NACT12,NACT13,NOST5,NACT14,NACT15,NACT16
4  FORMAT(12I4/12I4)
5
6  STORE Q,P. ALSO T2,T3. CALCULATE B2,B3.
7
8  DO 120 JET = 1,INO1
9  READ(5,110) T2(JET),T3(JET),C(JET),P(JET)
10  FORMAT(2F5.1, 2F10.4)
11  B2(JET) = 1.0/ (1.0 + RATE) * T2(JET)
12  B3(JET) = 1.0/ (1.0 + RATE) * T3(JET)
13  CONTINUE
14
15  STORE VARIOUS RETURNS AND COSTS.
16
17  DO 140 JO = 1,INO2
18  READ(5,130) R(JO),C(JO)
19  F(JO) = 40.0 * K(JO)
20  FORMAT(2F10.2)
21  CONTINUE
22
23  READ(5,100) (NA(I),I=1,87),(NR(I),I=1,87),(NC(I),I=1,87),
24  (NG(I),I=1,87),(NF(I),I=1,87),(NH(I),I=1,87)
25  FORMAT(80I1/711)
26
27  READ TERMINAL VALUES AT THE FINAL STAGE.
28
29  READ(5,150) F01,F02
30  FORMAT(2F10.2)
31
32  DO 111 I = 1,87
33  IF(1.EC.7).OR.(1.EQ.27).OR.(1.EQ.29).OR.(1.EQ.32).OR.
34  (1.EQ.34).OR.(1.EQ.42).OR.(1.EQ.48).OR.(1.EQ.54).OR.
35  (1.EQ.58).OR.(1.EQ.60).OR.(1.EQ.64).OR.(1.EQ.68).OR.
36  (1.EQ.76).OR.(1.EQ.83).OR.(1.EQ.24).OR.(1.EQ.37)) Q(I) = 1.0
37  PA(I) = P(I)
38  CA(I) = C(I)
39  CONTINUE
40
41  READ(5,777) HA,MB
42  FORMAT(2I2)
43  IF(MA.EQ.1) GO TO 121
44  IF(VA.EQ.2) GO TO 122
45
46  DO 201 J = 1,87
47  IF(NA(J).EQ.1) CALL UPPER(P,Q,J)

```



```

56 201 CONTINUE
57 C
58 GC TC 123
59 C
60 122 DO 202 J = 1,87
61 IF(NA(J).EQ.1) CALL LOWER(P,Q,J)
62 202 CONTINUE
63 C
64 123 CONTINUE
65 IF(MR.EQ.1) GO TO 131
66 IF(MR.EQ.2) GO TO 132
67 DO 301 J = 1,87
68 IF(NB(J).EQ.1) CALL UPPER(P,Q,J)
69 301 CONTINUE
70 C
71 GO TO 133
72 C
73 132 DO 302 J = 1,87
74 IF(NB(J).EQ.1) CALL LOWER(P,Q,J)
75 302 CONTINUE
76 C
77 DO 997 MC = 1,2
78 IF(MC.EQ.1) GO TO 141
79 IF(MC.EQ.2) GO TO 142
80 DO 401 J = 1,87
81 IF(MC(J).EQ.1) CALL UPPER(P,Q,J)
82 401 CONTINUE
83 C
84 GO TO 143
85 C
86 142 DO 402 J = 1,87
87 IF(MC(J).EQ.1) CALL LOWER(P,Q,J)
88 402 CONTINUE
89 C
90 DO 996 MD = 1,2
91 IF(MD.EQ.1) GO TO 151
92 IF(MD.EQ.2) GO TO 152
93 DO 501 J = 1,87
94 IF(MD(J).EQ.1) CALL UPPER(P,Q,J)
95 501 CONTINUE
96 C
97 GC TC 153
98 C
99 152 DO 502 J = 1,87
100 IF(MD(J).EQ.1) CALL LOWER(P,Q,J)
101 502 CONTINUE
102 C
103 DO 995 ME = 1,2
104 IF(ME.EQ.1) GO TO 161
105 IF(ME.EQ.2) GO TO 162
106 DO 601 J = 1,87
107 IF(NF(J).EQ.1) CALL UPPER(P,Q,J)
108 601 CONTINUE
109 C
110 GO TO 163
111 C
112 162 DO 602 J = 1,87
113 IF(NF(J).EQ.1) CALL LOWER(P,Q,J)
114 602 CONTINUE
115 C

```

```

116 DO 594 MF = 1,2
117 IF(MF.EQ.1) GO TO 171
118 IF(MF.EQ.2) GO TO 172
119 DO 701 J = 1,87
120 IF(MF(J).EQ.1) CALL UPPER(P,0,J)
121 CCNTINUE
122 GO TO 173
123
124
125 DO 702 J = 1,87
126 IF(MF(J).EQ.1) CALL LOWER(P,0,J)
127 CCNTINUE
128 DO 993 MG = 1,2
129 IF(MG.EQ.1) GO TO 181
130 IF(MG.EQ.2) GO TO 182
131 DO 801 J = 1,87
132 IF(MG(J).EQ.1) CALL UPPER(P,0,J)
133 CCNTINUE
134
135 GO TO 183
136
137 DO 802 J = 1,87
138 IF(MG(J).EQ.1) CALL LOWER(P,0,J)
139 CCNTINUE
140
141 DO 992 MH = 1,2
142 WRITE(6,100)MA,MB,MC,MD,ME,MF,MG,MH
143 FORMAT(10X,'A-TRANSITIONS TYPE',I2/I1CX,'B-TRANSITIONS TYPE',I2/
144 '10X,'C-TRANSITIONS TYPE',I2/I1CX,'D-TRANSITIONS TYPE',I2/
145 '10X,'E-TRANSITIONS TYPE',I2/I1CX,'F-TRANSITIONS TYPE',I2/
146 '10X,'G-TRANSITIONS TYPE',I2/I1CX,'H-TRANSITIONS TYPE',I2//)
147 IF(MH.EQ.1) GO TO 191
148 IF(MH.EQ.2) GO TO 192
149 DO 901 J = 1,87
150 IF(MH(J).EQ.1) CALL UPPER(P,0,J)
151 CCNTINUE
152 GO TO 200
153
154 DO 902 J = 1,87
155 IF(MH(J).EQ.1) CALL LOWER(P,0,J)
156 CCNTINUE
157
158 DO 3000 I = 1,87
159 P2(I) = Q(I) * P(I)
160 P3(I) = Q(I) * (1.0 - P(I))
161 CCNTINUE
162
163 WRITE HEADINGS.
164
165 WRITE(6,1000)
166 FORMAT(IX,' N P3 I K TRIVAL Q OPT.VALUE REST K'//)
167
168
169
170
171
172
173
174
175

```

```

C ACSTAG = NUMBER OF STAGES IN THE SYSTEM
C NOSTI = NUMBER OF STATES AT STAGE I
C N = A VARIABLE DENOTING THE CURRENT STAGE
C I = A VARIABLE DENOTING THE CURRENT STATE

```

176
177
178
179
180
181
182
183
184
185
186
187
188
189
190
191
192
193
194
195
196
197
198
199
200
201
202
203
204
205
206
207
208
209
210
211
212
213
214
215
216
217
218
219
220
221
222
223
224
225
226
227
228
229
230
231
232
233
234
235

```
C  
N = C  
I1 = 1  
I2 = 2  
WRITE(6,160) N, I1, F01  
FLPRAT(I1,I2,2X,I1,79X,F10.2)  
WRITE (5,160) N, I2, F02  
160  
C  
DC 5000 N = 1,NDSTAG  
IF (N.EQ.1) GC TC 180  
IF (N.EQ.2) GO TO 200  
IF (N.EQ.3) GO TO 240  
IF (N.EQ.4) GC TC 380  
IF (N.EQ.5) GC TO 520  
IF (N.EQ.6) GC TO 580  
180 LU 190 I = 1,NDST1  
IF (I.EQ.1) CALL ZFRO (N, I, F11,P(2),C(3) )  
IF (I.EQ.2) CALL ZFRO (N, I, F12,P(4),C(4) )  
IF (I.EQ.3) CALL ZFRO(P,I,F13,R(5),C(5) )  
IF (I.EQ.4) CALL ZFRO (N, I, F14,R(6),C(6) )  
IF (I.EQ.5) CALL ZFRO (N, I, F15,R(7),C(7) )  
IF (I.EQ.6) CALL TWO (N,I, I,Q(1), C(8),F01,TV161,F16 )  
IF (I.EQ.7) CALL TWO (N,I, I,Q(2),C(9),F02,TV171,F17 )  
IF (I.EQ.8) CALL ZFRO (N,I,F18,R(10),C(10) )  
IF (I.EQ.9) CALL ZFRO (N,I,F19,R(11),C(11) )  
IF (I.EQ.10) CALL ZFRO (N,I,F20,R(12),C(12) )  
IF (I.EQ.11) CALL ZFRO (N,I,F21,R(13),C(13) )  
IF (I.EQ.12) CALL ZFRO (N,I,F22,R(14),C(14) )  
IF (I.EQ.13) CALL ZFRO(N,I,F23,R(15),C(15) )  
IF (I.EQ.14) CALL ZFRO(N,I,F24,R(16),C(16) )  
190 CONTINUE  
60 TC 5000  
C  
STAGE 2 STARTS HERE .  
MUST2 = NUMBER OF STATES AT STAGE 2 .  
C  
200 DC 230 I = 1,NDST2  
IF (I.EQ.1) CALL ZFRO (N,I,F21,P(17),C(17) )  
IF (I.EQ.2) CALL TWO(N,I,I,Q(3),C(18), F11,TV221,F22 )  
IF (I.EQ.3) CALLTWO (N,I,I,Q(4),C(19),F12,TV231,F23 )  
IF (I.EQ.4) CALL TWO(N,I,I,Q(5),C(20),F13,TV241,F24 )  
IF (I.EQ.5) CALL TWO (N,I,I,Q(6),C(21), F14,TV251, F25 )  
IF (I.EQ.6) GC TC 210  
IF (I.EQ.7) CALL TWO(N,I,I,Q(7),C(23),F18,TV271,F27 )  
IF (I.EQ.8) CALL TWO (N,I,I,Q(10),C(24),F19,TV281,F28 )  
IF (I.EQ.9) CALLTWO (N,I,I,C(11),C(25),F10,TV291,F29 )  
IF (I.EQ.10) CALL TWO(N,I,I,Q(12),C(26),F11,TV2101,F210 )  
IF (I.EQ.11) CALLTWO(N,I,I,C(13),C(27),F11,TV2121,F211 )  
IF (I.EQ.12) CALL ZFRO (N,I,F212,R(28),C(28) )  
IF (I.EQ.13) CALL ZFRO (N,I,F213,R(29),C(29) )  
IF (I.EQ.14) CALL ZFRO (N,I,F214,R(30),C(30) )  
IF (I.EQ.15) CALL ZFRO (N,I,F215,R(31),C(31) )  
IF (I.EQ.16) CALL TWO(N,I,I,Q(14),C(32),F13,TV2161,F216 )  
IF (I.EQ.17) CALL TWO(N,I,I,Q(15),C(33),F14,TV2171,F217 )  
IF (I.EQ.18) CALL ZFRO (N,I,F218,F(34),C(34) )  
IF (I.EQ.19) CALL ZFRO (N,I,F219,R(35),C(35) )  
IF (I.EQ.20) CALL ZFRO (N,I,F220,F(36),C(36) )  
IF (I.EQ.21) CALL ZFRO (N,I,F221,F(37),C(37) )  
C
```

```

236 GO TO 250
237
238 WE ARE AT STATE(2,5). THERE ARE 2 ACTIONS.
239 NACT1 = AA VARIABLE DENOTING THE NUMBER OF ACTIONS AT STATE(2,6).
240 K = THE CURRENT ACTION.
241
242 DO 220 K = 1,NACT1
243 IF (K.EQ.1) CALL CNE (N,I,K,Q(7),C(22),F15,TV261)
244 IF (K.EQ.2) CALL VALUE (N,I,K,Q(8),P(8),P2(8),P3(8),
245 1 B2(8),B3(8),R(22),C(22),R(9),C(9),R(8),C(8),F17,F16,TV262)
246 CONTINUE
247
248 F26 = A*AXI(TV261,TV262)
249
250 IF (ABS(F26-TV261).LT.O.CC001) CALL OPTIMA (N,I,F26,1)
251 IF (ABS(F26-TV262).LT.O.CC001) CALL OPTIMA (N,I,F26,2)
252 CCNTINUE
253
254 GO TO 500
255
256 AT THIS POINT STAGE 2 ENDS. STAGE 3 STARTS NOW.
257 NCST3 = NUMBER OF STATES AT STAGE 3.
258
259 DO 370 I = 1,NCST3
260 IF (I.EQ.1) GO TO 250
261 IF (I.EQ.2) GO TO 270
262 IF (I.EQ.3) GO TO 290
263 IF (I.EQ.4) GO TO 310
264 IF (I.EQ.5) CALL ZERU(N,I,F35,R(42),C(42))
265 IF (I.EQ.6) CALL ZERC(N,I,F36,R(43),C(43))
266 IF (I.EQ.7) GO TO 330
267 IF (I.EQ.8) CALL TWO (N,I,I,Q(36),C(45),F215,TV381,F38)
268 IF (I.EQ.9) CALL ZERO (N,I,F39,R(46),C(46))
269 IF (I.EQ.10) CALL ZERU (N,I,F310,R(47),C(47))
270 IF (I.EQ.11) GO TO 350
271 IF (I.EQ.12) CALL TWO(N,I,I,Q(39),C(49),F219,TV312),F312)
272 IF (I.EQ.13) CALL TWO(N,I,I,Q(40),C(50),F220,TV313),F313)
273 IF (I.EQ.14) CALL TWO(N,I,I,Q(41),C(51),F221,TV314),F314)
274 GO TO 370
275
276 WE ARE AT THE STATE (3,1). THERE ARE 3 ACTIONS.
277 NACT2 = NUMBER OF ACTIONS AT STATE (3,1).
278
279 DO 250 K = 1,NACT2
280 IF (K.EQ.1) CALL CNE (N,I,K,Q(24),C(38),F219,TV311)
281 IF (K.EQ.2) CALL VALUE(N,I,K,Q(25),P(25),P2(25),P3(25),
282 1 B2(25),B3(25),R(38),C(38),R(25),C(25),R(24),C(24),F29,F28,TV312)
283 IF (K.EQ.3) CALL VALUE (N,I,K,Q(26),P(26),P2(26),P3(26),
284 1 B2(26),B3(26),R(38),C(38),K(23),C(23),R(22),C(22),F27,F26,TV313)
285 CONTINUE
286
287 F31 = A*AXI(TV311,TV312,TV313)
288
289 IF (ABS(F31-TV311).LT.O.CC001) CALL OPTIMA(N,I,F31,1)
290 IF (ABS(F31-TV312).LT.O.CC001) CALL OPTIMA(N,I,F31,2)
291 IF (ABS(F31-TV313).LT.O.CC001) CALL OPTIMA(N,I,F31,3)
292 GO TO 370
293
294 WE ARE AT STATE (3,2). THERE ARE 2 ACTIONS.
295 NACT3 = NUMBER OF ACTIONS AT STATE (3,2).

```

```

298 DC 280 K = 1,NACT3
299 IF (K.EQ.1) CALL ONE(N,I,K,Q(27),C(39),F212,TV321)
300 IF (K.EQ.2) CALL VALUE(N,I,K,Q(29),P(28),P2(28),P3(28),
301 1P2(28),R(28),C(39),R(27),C(27),R(26),C(26),F211,F210,TV322)
302 CCNTINUE
303
304 F32 = AMAX1( TV321, TV322 )
305
306 IF ( ABS ( F32-TV321 ) .LT. C.CC001 ) CALL OPTIMA(N,I,F32,1)
307 IF ( ABS ( F32-TV322 ) .LT. C.CC001 ) CALL OPTIMA(N,I,F32,2)
308 GC TO 370
309
310 WE ARE AT STATE(3,3). THERE ARE 3 ACTIONS.
311 NACT4 = NUMBER OF ACTIONS AT (3,3).
312
313 DC 300 K = 1,NACT4
314 IF(K.EQ.1) CALL ONE(N,I,K,C(29),C(40),F213,TV331)
315 IF(K.EQ.2) CALL VALUE(N,I,K,Q(30),P(30),P2(30),P3(30),
316 1R2(30),R(40),C(40),R(25),C(24),C(24),F29,F28,TV332)
317 IF(K.EQ.3) CALL VALUE(N,I,K,Q(31),P(31),P2(31),P3(31),
318 1R2(31),R(40),C(40),R(23),C(23),R(22),C(22),F27,F26,TV333)
319 CCNTINUE
320
321 F33 = AMAX1(TV331,TV332,TV333)
322
323 IF (ABS (F33-TV331) .LT. C.CC001) CALL OPTIMA (N,I,F33,1)
324 IF (ABS (F33-TV332) .LT. C.CC001) CALL OPTIMA (N,I,F33,2)
325 IF (ABS (F33-TV333) .LT. C.CC001) CALL OPTIMA (N,I,F33,3)
326 GC TO 370
327
328 WE ARE AT STATE(3,4). THERE ARE 2 ACTIONS.
329 NACT5 = NUMBER OF ACTIONS AT (3,4).
330 K = CURRENT ACTION .
331
332 DC 320 K = 1,NACT5
333 IF (K.EQ.1) CALL ONE(N,I,K,Q(32),C(41),F212,TV341)
334 IF (K.EQ.2) CALL VALUE(N,I,K,Q(33),P(33),P2(33),P3(33),
335 1R2(33),R(41),C(41),R(27),C(27),P(26),C(26),F211,F210,TV342)
336 CCNTINUE
337
338 F34 = AMAX1(TV341,TV342)
339
340 IF (ABS(F34-TV341) .LT. C.CC001) CALL OPTIMA(N,I,F34,1)
341 IF (ABS(F34-TV342) .LT. C.CC001) CALL OPTIMA(N,I,F34,2)
342 GC TO 370
343
344 WE ARE AT (3,7). THERE ARE 2 ACTIONS.
345 NACT6 = NUMBER OF ACTIONS AT STATE(3,7).
346
347 DC 340 K = 1,NACT6
348 IF(K.EQ.1) CALL ONE(N,I,K,Q(34),C(44),F214,TV371)
349 IF(K.EQ.2) CALL VALUE(N,I,K,Q(35),P(35),P2(35),P3(35),
350 1R2(35),R(44),C(44),R(27),C(27),R(26),C(26),F211,F210,TV372)
351 CCNTINUE
352
353 F37 = AMAX1(TV371,TV372)
354
355 IF (ABS(F37-TV371) .LT. C.CC001) CALL OPTIMA(N,I,F37,1)

```

```

357 GO TO 370
358
359 WE ARE AT (3,11). THERE ARE 2 ACTIONS.
360 C NACT7 = NUMBER OF ACTIONS AT (3,11).
361 C
362 DD 360 K = I,NACT7
363 IF(K.EQ.1) CALL CNE(N,I,K,C(37),C(48),F214,TV3111)
364 IF(K.EQ.2) CALL VALUE(N,I,K,Q(36),P(36),P2(28),P3(38),R2(38),
365 1R3(35),R(48),C(48),R(35),C(53),R(32),C(32),F217,F216,TV3112)
366 CCONTINUE
367 C
368 F311 = AMAX1(TV2111,TV3112)
369 C
370 IF(ABS(F311-TV3111).LT.0.00001) CALL OPTIMA(N,I,F311,1)
371 IF(ABS(F311-TV3112).LT.0.00001) CALL OPTIMA(N,I,F311,2)
372 C
373 CCONTINUE
374 C
375 GO TO 500
376 C
377 STAGE 3 ENDS HERE AND STAGE 4 STARTS.
378 C NCS14 = NUMBER OF STATES IN STAGE 4.
379 C
380 DD 510 I = 1,NCS14
381 IF(I.EQ.1) CALL ZERO(N,I,F41,R(52),C(52) )
382 IF(I.EQ.2) CALL ZERO(N,I,F42,R(53),C(53) )
383 IF(I.EQ.3) GO TO 390
384 IF(I.EQ.4) GO TO 410
385 IF(I.EQ.5) GO TO 430
386 IF(I.EQ.6) GO TO 450
387 IF(I.EQ.7) GO TO 470
388 IF(I.EQ.8) GO TO 490
389 IF(I.EQ.9) CALL TWJ(M,I,1,Q(66),C(60),F39,TV491,F49)
390 IF(I.EQ.10) CALLTWC(N,I,1,C(67),C(61),F310,TV4101,F410)
391 GO TO 510
392 C
393 STATE(4,3).THERE ARE 6 ACTIONS.
394 C NACT9 = NUMBER OF ACTIONS AT STATE(4,3)
395 C
396 DD 400 K = I,NACT9
397 IF(K.EQ.1) CALL ONE(N,I,K,Q(42),C(54),F21,TV431)
398 IF(K.EQ.2) CALL VALUE(N,I,K,Q(43),P(43),P2(43),P3(43),R2(43),
399 1R3(43),R(54),C(54),R(19),R(18),C(18),F23,F22,TV432)
400 IF(K.EQ.3) CALLVALUE(N,I,K,Q(44),P(44),P2(44),P3(44),R2(44),
401 1R3(44),R(54),C(54),R(21),R(20),C(20),F25,F24,TV433)
402 IF(K.EQ.4) CALL VALUE(N,I,K,Q(45),P(45),P2(45),P3(45),R2(45),
403 1R3(45),R(54),C(54),R(23),R(22),C(22),F27,F26,TV434)
404 IF(K.EQ.5) CALL VALUE(N,I,K,Q(46),P(46),P2(46),P3(46),R2(46),
405 1R3(46),R(54),C(54),R(25),R(24),C(24),F28,F28,TV435)
406 IF(K.EQ.6) CALL VALUE(N,I,K,Q(47),P(47),P2(47),P3(47),R2(47),
407 1R3(47),R(54),C(54),R(27),R(26),C(26),F211,F210,TV436)
408 CCONTINUE
409 C
410 F43 = AMAX1(TV431,TV432,TV433,TV434,TV435,TV436)
411 C
412 IF(ABS(F43-TV431).LT.0.00001) CALL OPTIMA(N,I,F43,1)
413 IF(ABS(F43-TV432).LT.0.00001) CALL OPTIMA(N,I,F43,2)
414 IF(ABS(F43-TV433).LT.0.00001) CALL OPTIMA(N,I,F43,3)
415 IF(ABS(F43-TV434).LT.0.00001) CALL OPTIMA(N,I,F43,4)

```

```

417 IF(ARS(F43-TV436),LT,0.00001) CALL OPTIMA(N,I,F43,6)
418
419 GC TO 510
420
421 WE ARE AT STATE (4,4) .THERE ARE 6 ACTIONS.
422 NACT19 = NUMBER OF ACTIONS AT STATE(4,4).
423
424 CF 420 K = 1,NACT9
425 IF(K,50.1) CALL ONE(N,I,K,C(48),C(55),F212,TV441)
426 IF(K,50.2) CALL VALUE(N,I,K,W(49),P(49),P2(49),P3(49),B2(49),
427 1B3(49),R(55),C(57),R(27),C(27),R(26),C(26),F211,F210,TV442)
428 IF(K,50.3) CALL VALUE(N,I,K,W(50),P(50),P2(50),P3(50),B2(50),
429 1B3(50),R(55),C(57),C(21),C(21),F(20),F25,F24,TV443)
430 IF(K,50.4) CALL VALUE(N,I,K,W(51),P(51),P2(51),P3(51),B2(51),
431 1B3(51),R(55),C(57),C(19),C(19),R(18),C(18),F23,F22,TV444)
432 IF(K,50.5) CALL VALUE(N,I,K,W(52),P(52),P2(52),P3(52),B2(52),
433 1B3(52),R(55),C(57),P(39),C(39),P(38),C(38),F32,F31,TV445)
434 IF(K,50.6) CALL VALUE(N,I,K,W(53),P(53),P2(53),P3(53),B2(53),
435 1B3(53),R(55),C(55),R(41),C(41),R(40),C(40),F34,F33,TV446)
436 CCNTINUE
437
438 F44 = AMAX1(TV441,TV442,TV443,TV444,TV445,TV446)
439
440 IF(ABS(F44-TV441),LT,0.00001) CALL OPTIMA(N,I,F44,1)
441 IF(ABS(F44-TV442),LT,0.00001) CALL OPTIMA(N,I,F44,2)
442 IF(ABS(F44-TV443),LT,0.00001) CALL OPTIMA(N,I,F44,3)
443 IF(ABS(F44-TV444),LT,0.00001) CALL OPTIMA(N,I,F44,4)
444 IF(ABS(F44-TV445),LT,0.00001) CALL OPTIMA(N,I,F44,5)
445 IF(ABS(F44-TV446),LT,0.00001) CALL OPTIMA(N,I,F44,6)
446
447 GO TO 510
448
449 WE ARE AT STATE (4,5) .THERE ARE 4 ACTIONS.
450 NACT10 = NUMBER OF ACTIONS AT STATE (4,5).
451
452 CO 440 K = 1,NACT10
453 IF(K,50.1) CALL ONE(N,I,K,C(54),C(56),F35,TV451)
454 IF(K,50.2) CALL VALUE(N,I,K,W(55),P(55),P2(55),P3(55),B2(55),
455 1B3(55),R(55),C(56),R(45),C(45),R(44),C(44),F38,F37,TV452)
456 IF(K,50.3) CALL VALUE(N,I,K,W(56),P(56),P2(56),P3(56),B2(56),
457 1B3(56),R(56),C(56),P(41),C(41),R(40),C(40),F34,F33,TV453)
458 IF(K,50.4) CALL VALUE(N,I,K,W(57),P(57),P2(57),P3(57),B2(57),
459 1B3(57),R(56),C(56),F(39),C(39),R(38),C(38),F32,F31,TV454)
460 CCNTINUE
461
462 F45 = AMAX1(TV451,TV452,TV453,TV454)
463
464 IF(ABS(F45-TV451),LT,0.00001) CALL OPTIMA(N,I,F45,1)
465 IF(ABS(F45-TV452),LT,0.00001) CALL OPTIMA(N,I,F45,2)
466 IF(ABS(F45-TV453),LT,0.00001) CALL OPTIMA(N,I,F45,3)
467 IF(ABS(F45-TV454),LT,0.00001) CALL OPTIMA(N,I,F45,4)
468
469 GO TO 510
470
471 WE ARE AT STATE (4,6) .THERE ARE 2 ACTIONS.
472 NACT11 = NUMBER OF ACTIONS AT (4,6).
473
474 UC 460 K = 1,NACT11
475 IF(K,50.1) CALL ONE(N,I,K,W(58),C(57),F36,TV461)

```

```

477 183(59),R(57),C(57),R(51),C(51),R(50),C(50),F314,F313,TV462)
478 CCNTINUE
479 C
480 F46 = AMAX1(TV461,TV462)
481 C
482 IF(ABS(F46-TV461).LT.0.00001) CALL OPTIMA(N,I,F46,1)
483 IF(ABS(F46-TV462).LT.0.00001) CALL OPTIMA(N,I,F46,2)
484 C
485 GO TO 510
486 C
487 WE ARE AT STATE (4,7). THERE ARE 4 ACTIONS.
488 NACT12 = NUMBER OF ACTIONS AT STATE (4,7).
489 C
490 DO 480 K = 1,NACT12
491 IF(K.EQ.1) CALL ONE(N,I,K,0(60),C(59),F35,TV471)
492 IF(K.EQ.2) CALL VALUE(N,I,K,0(61),P2(61),P3(61),B2(61),
493 183(51),R(58),C(58),R(41),C(41),R(40),C(40),F34,F33,TV472)
494 IF(K.EQ.3) CALL VALUE(N,I,K,0(62),P1(62),P2(62),B2(62),
495 183(62),R(58),C(58),R(39),C(39),R(38),C(38),F32,F31,TV473)
496 IF(K.EQ.4) CALL VALUE(N,I,K,0(63),P(63),P2(63),P3(63),R2(63),
497 183(63),R(58),C(58),R(51),C(51),R(50),C(50),F314,F313,TV474)
498 CCNTINUE
499 C
500 F47 = AMAX1(TV471,TV472,TV473,TV474)
501 C
502 IF(ABS(F47-TV471).LT.0.00001) CALL OPTIMA(N,I,F47,1)
503 IF(ABS(F47-TV472).LT.0.00001) CALL OPTIMA(N,I,F47,2)
504 IF(ABS(F47-TV473).LT.0.00001) CALL OPTIMA(N,I,F47,3)
505 IF(ABS(F47-TV474).LT.0.00001) CALL OPTIMA(N,I,F47,4)
506 C
507 GO TO 510
508 C
509 WE ARE AT STATE 4,R). THERE ARE 2 ACTIONS.
510 NACT13 = NUMBER OF ACTIONS AT (4,R).
511 C
512 DO 500 K = 1,NACT13
513 IF(K.EQ.1) CALL ONE(N,I,K,0(64),C(59),F36,TV481)
514 IF(K.EQ.2) CALL VALUE(N,I,K,0(65),P(65),P2(65),P3(65),B2(65),
515 183(65),R(59),C(59),R(51),C(51),R(50),C(50),F314,F313,TV482)
516 CCNTINUE
517 C
518 F43 = AMAX1(TV481,TV482)
519 C
520 IF(ABS(F43-TV481).LT.0.00001) CALL OPTIMA(N,I,F48,1)
521 IF(ABS(F43-TV482).LT.0.00001) CALL OPTIMA(N,I,F48,2)
522 C
523 CCNTINUE
524 C
525 GO TO 500
526 C
527 STAGE 5 STARTS HERE.
528 NACT15 = NUMBER OF STATES IN STAGE 5 .
529 C
530 DO 570 I = 1,NACT15
531 IF(I.EQ.1) GO TO 530
532 IF(I.EQ.2) GO TO 550
533 IF(I.EQ.3) CALL ZERC(N,I,F53,F(64),C(64))
534 GO TO 570
535 C

```

C NACT14 = NUMBER OF ACTIONS AT STATE (5,1).

```

530      CC 540 K = I-NACT14
531      IF (K.EQ.1) CALL CNE(N,I,K,Q(62),C(62),F41,TV511)
532      IF (K.EQ.2) CALL VALUE(N,I,K,Q(69),P(69),P2(69),P3(69),R2(69),
533      1B3(65),R(62),C(62),R(55),C(55),R(54),C(54),F44,F43,TV512)
534      IF (K.EQ.3) CALL VALUE(N,I,K,Q(70),P(70),P2(70),P3(70),R2(70),
535      1B3(70),R(62),C(62),R(51),C(51),R(50),C(50),F314,F313,TV513)
536      IF (K.EQ.4) CALL VALUE(N,I,K,Q(71),P(71),P2(71),P3(71),R2(71),
537      1B3(71),R(62),C(62),R(57),C(57),R(56),C(56),F46,F45,TV514)
538      IF (K.EQ.5) CALL VALUE(N,I,K,Q(72),P(72),P2(72),P3(72),R2(72),
539      1B3(72),R(62),C(62),R(59),C(59),R(58),C(58),F48,F47,TV515)
540      IF (K.EQ.6) CALL VALUE(N,I,K,Q(73),P(73),P2(73),P3(73),R2(73),
541      1B3(73),R(62),C(62),F(61),C(61),R(60),C(60),F410,F49,TV516)
542      IF (K.EQ.7) CALL VALUE(N,I,K,Q(74),P(74),P2(74),P3(74),R2(74),
543      1B3(74),R(62),C(62),P(39),C(39),R(38),C(38),F32,F31,TV517)
544      IF (K.EQ.8) CALL VALUE(N,I,K,Q(75),P(75),P2(75),P3(75),R2(75),
545      1B3(75),R(62),C(62),R(41),C(41),R(40),C(40),F34,F33,TV518)
546      CC CONTINUE
547
548      F51 = AMAX1(TV511,TV512,TV513,TV514,TV515,TV516,TV517,TV518)

```

F51 = AMAX1(TV511,TV512,TV513,TV514,TV515,TV516,TV517,TV518)

```

549      IF (ARS(F51-TV511).LT.0.CC0001) CALL OPTIMAIN,I,F51,1)
550      IF (ARS(F51-TV512).LT.0.CC0001) CALL OPTIMAIN,I,F51,2)
551      IF (ARS(F51-TV513).LT.0.CC0001) CALL OPTIMAIN,I,F51,3)
552      IF (ARS(F51-TV514).LT.0.CC0001) CALL OPTIMAIN,I,F51,4)
553      IF (ARS(F51-TV515).LT.0.CC0001) CALL OPTIMAIN,I,F51,5)
554      IF (ARS(F51-TV516).LT.0.CC0001) CALL OPTIMAIN,I,F51,5)
555      IF (ARS(F51-TV517).LT.0.CC0001) CALL OPTIMAIN,I,F51,7)
556      IF (ARS(F51-TV518).LT.0.CC0001) CALL OPTIMAIN,I,F51,8)

```

GO TO 570

WE ARE AT STATE (5,2). THERE ARE 7 ACTIONS.
NACT15 = NUMBER OF ACTIONS AT STATE (5,2).

```

550      CC 560 K = I-NACT15
551      IF (K.EQ.1) CALL CNE(N,I,K,Q(76),C(63),F42,TV521)
552      IF (K.EQ.2) CALL VALUE(N,I,K,Q(77),P(77),P2(77),P3(77),R2(77),
553      1B3(77),R(63),C(63),R(55),C(55),R(54),C(54),F44,F43,TV522)
554      IF (K.EQ.3) CALL VALUE(N,I,K,Q(78),P(78),P2(78),P3(78),R2(78),
555      1B3(78),R(63),C(63),R(21),C(21),R(20),C(20),F25,F24,TV523)
556      IF (K.EQ.4) CALL VALUE(N,I,K,Q(79),P(79),P2(79),P3(79),R2(79),
557      1B3(79),R(63),C(63),R(39),C(39),R(38),C(38),F32,F31,TV524)
558      IF (K.EQ.5) CALL VALUE(N,I,K,Q(80),P(80),P2(80),P3(80),R2(80),
559      1B3(80),R(63),C(63),R(41),C(41),R(40),C(40),F34,F33,TV525)
560      IF (K.EQ.6) CALL VALUE(N,I,K,Q(81),P(81),P2(81),P3(81),R2(81),
561      1B3(81),R(63),C(63),R(45),C(45),R(44),C(44),F30,F37,TV526)
562      IF (K.EQ.7) CALL VALUE(N,I,K,Q(82),P(82),P2(82),P3(82),R2(82),
563      1B3(82),R(63),C(63),R(61),C(61),R(60),C(60),F410,F49,TV527)
564      CC CONTINUE
565
566      F52 = AMAX1(TV521,TV522,TV523,TV524,TV525,TV526,TV527)

```

F52 = AMAX1(TV521,TV522,TV523,TV524,TV525,TV526,TV527)

```

567      IF (ARS(F52-TV521).LT.0.CC0001) CALL OPTIMAIN,I,F52,1)
568      IF (ARS(F52-TV522).LT.0.CC0001) CALL OPTIMAIN,I,F52,2)
569      IF (ARS(F52-TV523).LT.0.CC0001) CALL OPTIMAIN,I,F52,3)
570      IF (ARS(F52-TV524).LT.0.CC0001) CALL OPTIMAIN,I,F52,4)

```

```

597 IF(ARS(F52-TV526).LT.0.00001) CALL OPTIMAIN,I,F61,1)
598 IF(ARS(F52-TV527).LT.0.00001) CALL OPTIMAIN,I,F52,1)
599
600 CCONTINUE
601
602 GC TO 5000
603
604 C
605 C STAGE 6 STARTS FPCM HERE .THIS IS THE LAST STAGE.
606 C THERE IS ONE STATE ONLY,STATE (6,1).
607 C I = THE STATE VARIABLE.
608 C NACT16 = NUMBER OF ACTIONS AT STATE(6,1).
609 C
610 I = 1
611 DC 590 K = 1,NACT16
612 IF(K.EQ.1) CALL ONE(N,I,K,C(85),F53,TV611)
613 IF(K.EQ.2) CALL VALUE(N,I,K,Q(34),P(84),P2(84),P3(84),62(84),
614 182(84),R(85),C(85),P(85),C(85),K(85),C(85),F52,F51,TV612)
615 IF(K.EQ.3) CALL VALUE(N,I,K,Q(85),P(85),P2(85),P3(85),R2(85),
616 182(85),R(85),C(85),R(85),C(85),K(85),C(85),F31,F318,TV613)
617 IF(K.EQ.4) CALL VALUE(N,I,K,Q(85),P(86),P2(86),P3(86),R2(86),
618 182(86),R(86),C(86),R(43),C(43),K(48),C(48),F212,F211,TV614)
619 IF(K.EQ.5) CALL VALUE(N,I,K,Q(87),P(87),P2(87),P3(87),B2(87),
620 182(87),R(87),C(87),R(59),C(59),F(58),F(58),F43,F47,TV615)
621 CCONTINUE
622
623 C
624 C F61 = /MAXI(TV611,TV612,TV613,TV614,TV615)
625
626 IF(ARS(F61-TV611).LT.0.00001) CALL OPTIMAIN,I,F61,1)
627 IF(ARS(F61-TV612).LT.0.00001) CALL OPTIMAIN,I,F61,2)
628 IF(ARS(F61-TV613).LT.0.00001) CALL OPTIMAIN,I,F61,3)
629 IF(ARS(F61-TV614).LT.0.00001) CALL OPTIMAIN,I,F61,4)
630 IF(ARS(F61-TV,15).LT.0.00001) CALL OPTIMAIN,I,F61,5)
631 CCONTINUE
632
633 C
634 DC 591 LL=1,87
635 IF(NF(LL).EQ.119(LL)=01(LL)
636 IF(NC(LL).EQ.110(LL)=0A(LL)
637 CCONTINUE
638 DC 222 LL=1,87
639 IF(NF(LL).EQ.119(LL)=0A(LL)
640 IF(NC(LL).EQ.110(LL)=0A(LL)
641 CCONTINUE
642 DC 333 LL=1,87
643 IF(NF(LL).EQ.119(LL)=0A(LL)
644 IF(NC(LL).EQ.110(LL)=0A(LL)
645 CCONTINUE
646 DC 444 LL=1,87
647 IF(NF(LL).EQ.119(LL)=0A(LL)
648 IF(NC(LL).EQ.110(LL)=0A(LL)
649 CCONTINUE
650 DC 555 LL=1,87
651 IF(NF(LL).EQ.119(LL)=0A(LL)
652 IF(NC(LL).EQ.110(LL)=0A(LL)
653 CCONTINUE
654 DC 666 LL=1,87
655 IF(NF(LL).EQ.119(LL)=0A(LL)
656 IF(NC(LL).EQ.110(LL)=0A(LL)
657 CCONTINUE
658
659 CCONTINUE
660
661 CCONTINUE
662
663 CCONTINUE
664
665 CCONTINUE
666
667 CCONTINUE
668
669 CCONTINUE
670
671 CCONTINUE
672
673 CCONTINUE
674
675 CCONTINUE
676
677 CCONTINUE
678
679 CCONTINUE
680
681 CCONTINUE
682
683 CCONTINUE
684
685 CCONTINUE
686
687 CCONTINUE
688
689 CCONTINUE
690
691 CCONTINUE
692
693 CCONTINUE
694
695 CCONTINUE
696
697 CCONTINUE
698
699 CCONTINUE
700
701 CCONTINUE
702
703 CCONTINUE
704
705 CCONTINUE
706
707 CCONTINUE
708
709 CCONTINUE
710
711 CCONTINUE
712
713 CCONTINUE
714
715 CCONTINUE
716
717 CCONTINUE
718
719 CCONTINUE
720
721 CCONTINUE
722
723 CCONTINUE
724
725 CCONTINUE
726
727 CCONTINUE
728
729 CCONTINUE
730
731 CCONTINUE
732
733 CCONTINUE
734
735 CCONTINUE
736
737 CCONTINUE
738
739 CCONTINUE
740
741 CCONTINUE
742
743 CCONTINUE
744
745 CCONTINUE
746
747 CCONTINUE
748
749 CCONTINUE
750
751 CCONTINUE
752
753 CCONTINUE
754
755 CCONTINUE
756
757 CCONTINUE
758
759 CCONTINUE
760
761 CCONTINUE
762
763 CCONTINUE
764
765 CCONTINUE
766
767 CCONTINUE
768
769 CCONTINUE
770
771 CCONTINUE
772
773 CCONTINUE
774
775 CCONTINUE
776
777 CCONTINUE
778
779 CCONTINUE
780
781 CCONTINUE
782
783 CCONTINUE
784
785 CCONTINUE
786
787 CCONTINUE
788
789 CCONTINUE
790
791 CCONTINUE
792
793 CCONTINUE
794
795 CCONTINUE
796
797 CCONTINUE
798
799 CCONTINUE
800
801 CCONTINUE
802
803 CCONTINUE
804
805 CCONTINUE
806
807 CCONTINUE
808
809 CCONTINUE
810
811 CCONTINUE
812
813 CCONTINUE
814
815 CCONTINUE
816
817 CCONTINUE
818
819 CCONTINUE
820
821 CCONTINUE
822
823 CCONTINUE
824
825 CCONTINUE
826
827 CCONTINUE
828
829 CCONTINUE
830
831 CCONTINUE
832
833 CCONTINUE
834
835 CCONTINUE
836
837 CCONTINUE
838
839 CCONTINUE
840
841 CCONTINUE
842
843 CCONTINUE
844
845 CCONTINUE
846
847 CCONTINUE
848
849 CCONTINUE
850
851 CCONTINUE
852
853 CCONTINUE
854
855 CCONTINUE
856
857 CCONTINUE
858
859 CCONTINUE
860
861 CCONTINUE
862
863 CCONTINUE
864
865 CCONTINUE
866
867 CCONTINUE
868
869 CCONTINUE
870
871 CCONTINUE
872
873 CCONTINUE
874
875 CCONTINUE
876
877 CCONTINUE
878
879 CCONTINUE
880
881 CCONTINUE
882
883 CCONTINUE
884
885 CCONTINUE
886
887 CCONTINUE
888
889 CCONTINUE
890
891 CCONTINUE
892
893 CCONTINUE
894
895 CCONTINUE
896
897 CCONTINUE
898
899 CCONTINUE
900
901 CCONTINUE
902
903 CCONTINUE
904
905 CCONTINUE
906
907 CCONTINUE
908
909 CCONTINUE
910
911 CCONTINUE
912
913 CCONTINUE
914
915 CCONTINUE
916
917 CCONTINUE
918
919 CCONTINUE
920
921 CCONTINUE
922
923 CCONTINUE
924
925 CCONTINUE
926
927 CCONTINUE
928
929 CCONTINUE
930
931 CCONTINUE
932
933 CCONTINUE
934
935 CCONTINUE
936
937 CCONTINUE
938
939 CCONTINUE
940
941 CCONTINUE
942
943 CCONTINUE
944
945 CCONTINUE
946
947 CCONTINUE
948
949 CCONTINUE
950
951 CCONTINUE
952
953 CCONTINUE
954
955 CCONTINUE
956
957 CCONTINUE
958
959 CCONTINUE
960
961 CCONTINUE
962
963 CCONTINUE
964
965 CCONTINUE
966
967 CCONTINUE
968
969 CCONTINUE
970
971 CCONTINUE
972
973 CCONTINUE
974
975 CCONTINUE
976
977 CCONTINUE
978
979 CCONTINUE
980
981 CCONTINUE
982
983 CCONTINUE
984
985 CCONTINUE
986
987 CCONTINUE
988
989 CCONTINUE
990
991 CCONTINUE
992
993 CCONTINUE
994
995 CCONTINUE
996
997 CCONTINUE
998
999 CCONTINUE
1000 CCONTINUE

```

```

596 CONTINUE
597 GO 666 LL=1,37
598 IF(AC(LL),EQ,1)P(LL)=PA(LL)
599 IF(AC(LL),EQ,1)D(LL)=DA(LL)
600 CONTINUE
601 CONTINUE
602 CONTINUE
603 CONTINUE
604 STOP
605 END
606
607 SUBROUTINE ZERO CALCULATES THE TERMINAL VALUES AT THE INTERMEDIATE
608 STAGES AND WRITES N,I, AND F
609 WE CALL SUBROUTINE ZERO WHEN A TERMINAL STATE OCCURS.
610
611 SUBROUTINE ZERO (N,I,F ,ANOW,CNOW)
612 F = FNOW-CNOW
613 WRITE(6,100) N,I,F
614 FORMAT(1X,13,2X,13,79X,F10.2)
615 RETURN
616 END
617
618 SUBROUTINE ONE CALCULATES THE VALUE OF THE STATE UNDER ACTION1
619 WE CALL SUBROUTINE ONE WHENEVER ACTION 1APPEARS,TOGETHER
620 WITH OTHER ACTIONS.
621
622 SUBROUTINE ONE(N,I,K,Q,CNOW,FINEXT,TRIVAL)
623 TRIVAL = FINEXT
624 WRITE(6,200) N,I,K,Q,TRIVAL
625 FORMAT(1X,3(13,2X),F10.4,50X,F10.2)
626 RETURN
627 END
628
629 SUBROUTINE TWO A) CALCULATES THE TRIAL VALUE OF A STATE
630 UNDER ACTION 1,WHEN THIS ACTION IS THE ONLY ONE. B) IT SETS
631 THE TRIAL VALUE EQUAL TO OPTIMAL VALUE AND WRITES IT.
632 WE CALL SUBROUTINE TWO WHENEVER THERE IS ONLY ONE ACTION.
633
634 SUBROUTINE TWO (N,I,K,Q,CNOW,FINEXT,TRIVAL,FNOW)
635 TRIVAL = FINEXT
636 FNOW = TRIVAL
637 WRITE(6,200) N,I,K,Q,TRIVAL
638 FORMAT(1X,3(13,2X), F10.4,50X,F10.2)
639 WRITE(6,300) N,I,FNOW,K
640 FORMAT(1X,13,2X,13,79X,F10.2,2X,16)
641 RETURN
642 END
643
644 SUBROUTINE OPTIMA ASSIGNS THE BEST ACTION.
645
646 SUBROUTINE OPTIMA (N,I,F,KBEST)
647 WRITE(6,300) N,I,F,KBEST
648 FORMAT(1X,13,2X,13,79X,F10.2,2X,15)
649 RETURN
650 END
651
652 SUBROUTINE VALUE CALCULATES THE TRIAL VALUE OF A STATE

```

```

716 SUBROUTINE VALUE (N,I,K,C,P,P2,P3,DISC2,DISC3,RNCW,CNCH,
717 P2EXT,C2EXT,F2EXT,C3EXT,F2MEXT,F2MEXT,F2MEXT,TRIVAL)
718 F1VAL = DISC2*P2 - (RNCW+CNCH*F2MEXT) +
719 DISC3*P3 - (R2C+CNCH*F2MEXT)+P2C-CNCH
720 WRITE(G,200) F1,K,Q,P,P2,P3, TRIVAL
721 PC=PT(IX,2(IX,2X),2(F10.4,2X),12X,2(F10.4,2X),F10.2 )
722 RETURN
723 END
724
725 C
726 C
727 SUBROUTINE UPPER(P,Q,J)
728 DIMENSION Q(7),P(87)
729 IF(Q(J).GE.0.1)N(J)=1.0
730 IF(Q(J).LT.0.1)Q(J)=10.-Q(J)
731 IF(P(J).GE.0.9)P(J)=10.-Q(P(J))-Q.9
732 IF(P(J).LT.0.9)P(J)=0.0
733 RETURN
734 END
735 SUBROUTINE LOWER(P,Q,J)
736 DIMENSION Q(7),P(87)
737 IF(Q(J).GE.0.9)P(J)=10.-Q(Q(J))-Q.9
738 IF(Q(J).LT.0.9)Q(J)=0.0
739 IF(P(J).GE.0.1)P(J)=1.0
740 IF(P(J).LT.0.1)P(J)=10.-Q(P(J))
741 RETURN
742 END

```

END OF FILE

SI 000000

Computer Output

A-TRANSITIONS TYPE 1
 B-TRANSITIONS TYPE 2
 C-TRANSITIONS TYPE 1
 D-TRANSITIONS TYPE 1
 E-TRANSITIONS TYPE 2
 F-TRANSITIONS TYPE 2
 G-TRANSITIONS TYPE 1
 H-TRANSITIONS TYPE 1

N	I	K	C	P	P2	P3	TRIVAL	CPT.VALUE	REST	K
0	1							52575.00		
0	2							78875.00		
1	1							45955.00		
1	2							30590.00		
1	3							56775.00		
1	4							34402.00		
1	5							72775.00		
1	6	1	1.0000				52575.00	52575.00		1
1	7	1	1.0000				78875.00	78875.00		1
1	8							76875.00		
1	9							39452.00		
1	10							72775.00		
1	11							3852.00		
1	12							72775.00		
1	13							39402.00		
1	14							43185.00		
1	15							43534.00		

2	2	1	1.0000						56775.00					30590.00	1
2	2	1	1.0000						56775.00					56775.00	1
2	2	1	1.0000						34402.00					34402.00	1
2	2	1	1.0000						72779.00					72779.00	1
2	2	2	0.6000						81944.56					81944.56	2
2	2	1	1.0000						39842.00					39842.00	1
2	2	1	1.0000						72779.00					72779.00	1
2	2	1	1.0000						39842.00					39842.00	1
2	2	1	1.0000						72779.00					72779.00	1
2	2	1	1.0000						39842.00					39842.00	1
2	2	1	1.0000						72779.00					72779.00	1
2	2	1	1.0000						39842.00					39842.00	1
2	2	1	1.0000						63185.00					63185.00	1
2	2	1	1.0000						43834.00					43834.00	1
2	2	1	1.0000						24087.00					24087.00	1
2	2	2	0.3750						37056.25					37056.25	2
2	2	3	0.2188						32376.14					32376.14	2
2	2	1	1.0000						23704.00					23704.00	2
2	2	2	0.1875						30432.43					30432.43	2
2	2	1	1.0000						24067.00					24067.00	2
2	2	2	0.4997						41962.73					41962.73	2
2	2	3	0.1666						30973.65					30973.65	2
2	2	1	1.0000						23704.00					23704.00	2
2	2	2	0.0340						25671.83					25671.83	2
2	2	1	1.0000						32984.00					32984.00	2
2	2	2	0.4999						48305.87					48305.87	2
2	2	1	1.0000						24509.00					24509.00	2
2	2	1	1.0000						24509.00					24509.00	1
2	2	2	0.5545						53083.55					53083.55	1
2	2	1	1.0000						32984.00					32984.00	2
2	2	2	0.5545						53083.55					53083.55	2

Line	Code	Description	Amount	Quantity	Unit	Total
1	1.0000					
2	C.1462	C.1153	0.0169			
3	C.0639	0.0750	0.0564			
4	C.2256	0.2068	0.0467			
5	C.1056	C.1362	0.1056			
6	C.0364	0.1250	0.0046			
1	1.0000					
2	C.0324	0.1250	0.0048			
3	C.0567	C.0750	0.0367			
4	C.1923	C.1153	C.0222			
5	0.0384	0.2459	0.0096			
6	0.1153	C.0041	0.1043			
1	1.0000					
2	C.5625	0.2272	0.1278			
3	0.1250	0.0361	0.1170			
4	0.2914	C.0666	0.1944			
1	1.0000	C.1900	0.1350			
2	C.7500					
1	1.0000					
2	C.7777	C.0361	0.2600			
3	0.1111	C.6666	0.0741			
4	0.4165	C.1900	0.0750			
1	1.0000	C.1900	0.1519			
2	C.8435					
1	1.0000					
2	1.0000					
3	1.0000					
4	1.0000					
5	1.0000					
6	1.0000					
7	1.0000					
8	1.0000					
9	1.0000					
10	1.0000					
1	1.0000					
2	0.0207	0.1223	0.0047			
3	0.1855	0.1900	0.0036			
4	0.1895	C.1000	0.0187			
5	0.7632	C.2000	0.1506			
6	0.1650	C.1250	0.0349			
7	0.0125	C.6666	0.0083			
8	0.0414	0.0361	0.0388			
1	1.0000					
2	0.7631	0.1223	0.2459			
3	0.0050	0.0750	0.0007			
4	0.0328	C.6666	0.0319			
5	0.0725	C.0361	0.0677			
6	0.0195	0.2272	0.0045			
7	0.0789	0.1250	0.0099			
1	1.0000					
2	1.0000					
3	1.0000					
4	1.0000					
5	1.0000					
6	1.0000					
7	1.0000					
8	1.0000					
9	1.0000					
10	1.0000					
1	1.0000					
2	1.0000					
3	1.0000					
4	1.0000					
5	1.0000					
6	1.0000					
7	1.0000					
8	1.0000					
9	1.0000					
10	1.0000					
1	1.0000					
2	1.0000					
3	1.0000					
4	1.0000					
5	1.0000					
6	1.0000					
7	1.0000					
8	1.0000					
9	1.0000					
10	1.0000					

1772.97
15153.79
14898.25

U.0531
C.0147
0.0166

U.1719
0.0070
0.0046

U.7887
0.3215
0.2000

U.1330
0.0217
0.0232

3
4
5

1
1
1

6
6
6

21273.56 2

BIBLIOGRAPHY

- ACKOFF, R. (1975): A Management scientist looks at the Education and Education looks back.
In: "Management in Education", Dobson *et al.* (ed) pp.99-100.
- ADELMAN, I. (1966): A Linear programming model of Educational planning: A case study of Argentina.
In: "The Theory and Design of Economic Development", Adelman, I. and Thorbecke, E. (ed), John Hopkins Press, pp.385-412.
- ALMOND, M. (1966): An Algorithm for constructing University timetables.
The Computer Journal, Vol.8, pp.331-340.
- ANDREW, G. and COLLINS, R. (1971): Matching faculty to courses.
College University, Vol.46, pp.83-89.
- ARMITAGE, P., SMITH, C. and ALPER, P. (1969): Decision models for Educational planning.
Allen Lane, The Penguin Press.
- ARMITAGE, P. (1973): Planning in Practice: the Work and Legacy of the External Committee.
In: "Decision Making in British Education".
Fowler, J. *et al.* (ed), Heinemann, pp.206-226.
- BALINSKI, W. (1974): A multiperiod model for a training program.
Socio-Economic Planning Sciences, Vol.8, pp.135-140.
- and REISMAN, (1972): Some manpower planning models based on levels of educational attainment.
Management Science, Vol.18, B691-B705.
- BARRACLOUGH, E. (1965): The application of a digital computer to the construction of timetables.
The Computer Journal, Vol.8, pp.135-146.
- BECKER, G. (1964): Human Capital: A theoretical and empirical analysis with special reference to Education.
Princeton University Press.
- BELLMAN, R. (1957): Dynamic programming.
Princeton University Press.
- BELFORD, P. and RATLIFF, D. (1972): A network-flow model for racially balancing schools.
Operations Research, Vol.20, pp.619-628.
- BENARD, J. (1967): General optimization model for the Economy and Education.
In: "Mathematical models in Educational Planning",
O.E.C.D., pp.207-243.
- BLAUG, M. (1967): Approaches to educational planning.
Economic Journal, Vol.77, pp.262-287.

- BLAUG, M. (1970): Economics of Education: A selected Annotated Bibliography.
Pergamon Press.
- (1972): An introduction to the Economics of Education.
Penguin Books.
- , LAYARD, P.R.G., and WOODHALL, M. (1969): The causes of Graduate Unemployment.
Allen Lane, The Penguin Press.
- BOWEN, W.G. (1963): Assessing the economic contribution of Education: An appraisal of alternative approaches.
In: Robbin's Report, pp.73-96.
- BOWLES, S. (1971): Planning Educational systems for Economic growth.
Harvard University Press.
- BRUNO, J. (1969a): Using Linear programming salary valuation models in collective bargaining negotiations with teacher unions.
Socio-Economic Planning Sciences, Vol.3, pp.103-117.
- (1969b): A mathematical programming approach to school finance.
Socio-Economic Planning Sciences, Vol.3, pp.1-12.
- (1970): The function of Operations Research specialists in large urban school districts.
I.E.E.E. Transactions on systems science and Cybernetics, SSC-6, No.6, pp.293-302.
- (1971): An alternative to uniform expenditure reductions in multiple resource state finance programs.
Management Science, Vol.17, pp.B386-B398.
- CASE, C.M. and CLARKE, S.C. (1967): A bibliographic guide to Operations Analysis of Education.
U.S. Department of Health, Education and Welfare Office of Education, Technical note No.43.
- CLARKE, S.C. and SURKIS, J. (1968): An Operations Research approach to racial desegregation of school systems.
Socio-Economic Planning Sciences, Vol.1, pp.259-272.
- COMAY, Y., MELNIK, A. and POLLATSCHEK, M.A. (1973): The option value of Education and the optimal path for investment in Human Capital.
International Economic Review, Vol.14, pp.421-435.
- COOMBS, P.H. (1970): What is educational planning?
UNESCO: International Institute for Educational Planning.
- CORREA, H. (1965): Planning the educational curriculum.
Kyclos, Vol.18, pp.685-691.
- DAVIS, R.G. (1966): Planning Human resource development: Educational models and schemata.
Rand McNally.

- DENISON, E.F. (1964): Proportion of income differentials among education groups due to additional education: the evidence of the Wolfe-Smith survey.
In: The Residual factor and Economic growth.
O.E.C.D., pp.86-100.
- EDUCATIONAL PLANNING PAPER No.2 (1970): Student numbers in Higher Education in England and Wales.
H.M.S.O.
- FOX, K. (1972): Economic Analysis for Educational Planning.
The John Hopkins University Press.
- and SENGUPTA, J. (1968): The specification of Econometric models for planning Educational Systems: An Appraisal of alternative approaches.
Kyclos, Vol.21, pp.665-694.
- FEUERMAN, M. and WEISS, H. (1973): A mathematical programming model for test construction and scoring.
Management Science, Vol.19, pp.961-966.
- GOLLADAY, F. and ADELMAN, I. (1972): Socio-economic Policy alternatives in National Development: A Parametric programming Analysis.
Behavioral Science, Vol.17, pp.204-220.
- GRAVES, R. and THOMAS, W. (1971): A classroom location allocation model for Campus planning.
Socio-Economic Planning Sciences, Vol.5, pp.191-204.
- (1976): An analytical approach to Academic Department location in a multicampus University.
Socio-Economic Planning Sciences, Vol.10, pp.93-100.
- HADLEY, G. (1964): Non Linear and Dynamic Programming.
Addison-Wesley.
- HASTINGS, N. (1973): Dynamic Programming with management applications.
Butterworths.
- HECKMAN, L. and TAYLOR, H. (1969): School reasoning to achieve racial balance: A Linear programming approach.
Socio-Economic Planning Sciences, Vol.3, pp.127-133.
- HILLIER, F. and LIEBERMAN, G. (1974): Introduction to Operations Research.
Holden-Day.
- HIMMELBLAU, D.M. (1972): Applied Nonlinear Programming.
McGraw-Hill Book Company.
- HOLLISTER, R.G. (1966): A Technical Evaluation of the First Stage of the Mediterranean Regional Project.
O.E.C.D.
- HUFNER, K. (1968): Economics of higher education and educational planning: a bibliography.
Socio-Economic Planning Sciences, Vol.2, pp.25-101.

- JAMES REPORT (1974): Teacher Education and Training.
H.M.S.O.
- KOENINGSBERG, E. (1968): Mathematical Analysis applied to school attendance areas.
Socio-Economic Planning Sciences, Vol.1, pp.465-475.
- LAWRIE, N.L. (1969): An Integer Linear Programming model of a school time-tabling problems.
The Computer Journal, Vol.12, pp.307-316.
- LAYARD, P.R.G., KING, J. and MOSER, C. (1969): The Impact of Robbins.
Penguin.
- LEE, S. (1972): Goal Programming for Decision Analysis.
Auerbach.
- and CLAYTON, E. (1972): A Goal Programming model for Academic resource allocation.
Management Science, Vol.18, pp.395-408.
- LUTZ, R.P., DEVINE, M.D., KUMIN, H.J. and SMITH, W.C. (1972): An application of Operations Research to school desegregation.
Management Science, Vol.19, pp.B100-B110.
- McMILLAN, C. (1975): Mathematical Programming.
John Willey.
- McNAMARA, J. (1971): A Mathematical Programming approach to State-Local Program Planning in Vocational Education.
American Educational Research Journal, Vol.8, pp.335-365.
- (1973): Mathematical Programming models in educational planning.
Review of Educational Research, Vol.41, pp.419-446.
- MORRIS, V. (1973): Investment in Higher Education in England and Wales: The Human capital approach to Educational Planning.
In: Decision Making in British Education.
Fowler, J. *et al.* (ed), Heinemann, pp.284-308.
- MOSER, C.A. and LAYARD, P.R.G. (1964): Planning the Scale of Higher Education in Britain: Some statistical problems.
Journal of the Royal Statistical Society, series A, Vol.127, pp.493-513.
- NEWTON, R. and THOMAS, W. (1969): Design of School bus routes by computer.
Socio-Economic Planning Sciences, Vol.3, pp.75-85.
- O'BRIEN, R. (1969): Model for Planning the location and size of urban schools.
Socio-Economic Planning Sciences, Vol.2, pp.141-153.
- O.E.C.D. (1969): Systems Analysis for educational planning: Selected annotated bibliography.
- (1972): University planning and Management Techniques.
- (1973): Mathematical models for the Educational sector: A survey.
- (1974): Mathematical models for the Educational sector: Annexes.

- PARNES, H. (1962): Forecasting educational needs for Social Economic Development.
O.E.C.D.
- (1964): Planning education for economic and Social Development.
O.E.C.D.
- PLESSNER, Y., FOX, K., SANYAL, B. (1968): On the allocation of resources in a University Department.
Metroeconomica, Vol.20, pp.256-271.
- PROCEEDINGS OF THE SYMPOSIUM ON OPERATIONS ANALYSIS OF EDUCATION (1969).
Socio-Economic Planning Sciences, Vol.2, pp.103-517.
- PSOINOS, O.P. and XIROCOSTAS, D.A. (1973): A Dynamic Programming approach to establishing teaching posts in a centralised Educational system.
In: Proceedings of the Sixth IFORS International Conference on Operational Research.
ROSS, E. (ed), North-Holland, pp.315-323.
- ROBBINS REPORT (1963): Higher Education.
H.M.S.O. (Cmnd 2154).
- SCHROEDER, R. (1973): A survey of Management Science in University Operations.
Management Science, Vol.19, pp.895-906.
- (1974): Resource planning in University Management by Goal Programming.
Operations Research, Vol.22, pp.700-711.
- SCHULTZ, T.W. (1963): The Economic value of Education.
Columbia University Press.
- STIMSON, D. and THOMSON, R. (1974): Linear programming, busing and Educational Administration.
Socio-Economic Planning Sciences, Vol.8, pp.195-206.
- (1975): The importance of "Weltanschauung" in Operations Research: The case of the school busing problem.
Management Science, Vol.21, pp.1123-1132.
- STONE, R. (1965): A model of the Educational system.
Minerva, Vol.3, pp.172-186.
- TAFT, M.I. and REISMAN, A. (1967): Toward better curricula through computer selected sequencing of subject matter.
Management Science, Vol.13, pp.926-945.
- THONSTAND, T. (1969): Education and Manpower: Theoretical Models and Empirical Applications.
Oliver and Boyd.

- TINBERGEN, J. and BOS, H.C. (1964): A planning model for the Educational Requirements of Economic Development.
In: The Residual Factor and Economic Growth,
O.E.C.D., pp.147-169.
- UNESCO (1970): Educational planning: A world survey of problems and prospects.
- WALTERS, A., MANGOLD, J. and HARAN, E.G.P. (1976): A comprehensive Planning model for long range Academic Strategies.
Management Science, Vol.22, pp.727-738.
- WEITZ, H. (1969): An Assessment of the contribution of Operations Research to Educational Planning.
Technical paper No. XVID 4.
IBM.
- WOODHALL, M. (1970): Cost-Benefit analysis in educational planning.
UNESCO: International Institute for Educational Planning.
- WORLD YEARBOOK OF EDUCATION (1967): Educational Planning.
Bereday, G., Lauwerys, J. and Blaug, M. (ed).
Evans Brothers.
- YULE, M.P. (1968): Extensions to the Heuristic Algorithm for University Timetables.
The Computer Journal, Vol.10, pp.360-364.