



Durham E-Theses

The properties of fibre reinforced cement based sandwich beams

Saglam, B

How to cite:

Saglam, B (1976) *The properties of fibre reinforced cement based sandwich beams*, Durham theses, Durham University. Available at Durham E-Theses Online: <http://etheses.dur.ac.uk/8998/>

Use policy

The full-text may be used and/or reproduced, and given to third parties in any format or medium, without prior permission or charge, for personal research or study, educational, or not-for-profit purposes provided that:

- a full bibliographic reference is made to the original source
- a [link](#) is made to the metadata record in Durham E-Theses
- the full-text is not changed in any way

The full-text must not be sold in any format or medium without the formal permission of the copyright holders.

Please consult the [full Durham E-Theses policy](#) for further details.

THE PROPERTIES OF FIBRE REINFORCED

CEMENT BASED SANDWICH BEAMS

by

B. SAGLAM, B.Sc.

This thesis is submitted for the
degree of Master of Science to
University of Durham.

Department of Engineering Science
University of Durham.

November, 1976

ACKNOWLEDGEMENTS

I wish to record my gratitude to all those persons who have been connected in any way with this research and the production of the thesis, especially the technical staff of the Department of Engineering Science of the University of Durham.

Special thanks are due to my supervisor, Dr. G. M. Parton, for the guidance and constructive comments which he contributed during the course of the research.

CONTENTS

<u>CHAPTER</u>	<u>TITLE</u>	<u>PAGE</u>
1	<u>Historical Background</u>	2
2	<u>Core Material</u>	9
2.1	Introduction	9
2.2	The Polystyrene Beads	9
2.3	Pouring of Test Samples	10
2.4	Testing Procedure	14
2.5	Theory	14
2.6	Density	16
2.7	Discussions	21
3	<u>Fibre Reinforcement In Cement</u>	22
3.1	Introduction	22
3.2	Theoretical Considerations of Strength for Fibre Reinforcement	23
3.3	Laboratory Procedure	35
3.4	Discussion	43
4	<u>Sandwich Sections</u>	51
4.1	Introduction	51
4.2	Theoretical Considerations	52
4.3	Experiments and Procedure	59
4.4	Discussions	74
4.5	Beam Finite Element Analysis	76
4.6	Sandwich Slab	81

CONTENTS/continued

<u>CHAPTER</u>	<u>TITLE</u>	<u>PAGE</u>
4	4.7 Laboratory Procedure	81
	4.8 Testing of The Slab	85
	4.9 Slab Finite Element Analysis	90
	4.10 Discussions	94
5	<u>Conclusions</u>	96
Appendix I	<u>Details of Moulds</u>	98
Appendix II	<u>Computer Input and Output</u> <u>for Beam Finite Element Analysis</u>	103
Appendix III	<u>Computer Input and Output</u> <u>for Slab Finite Element Analysis</u>	115
References		129

<u>FIGURE</u>	<u>TITLE</u>	<u>PAGE</u>
2.1	Four-Point Test	15
2.2	Approximation of Failure Stress in Relationship to Water Cement Content	17
2.3	Effect of Water Cement Ratio on Density	18
2.4	Approximation of Modulus of Elasticity.	19
2.5	Approximation of Shear Modulus	20
3.1	Orientation of a Random Fibre	24
3.2	Density Ratios For Commonly Used Reinforcing Fibres To Binders	27
3.3	Centrally Notched Plate In Tension	29
3.4	Riveted Stiffener Crack Arresters	29
3.5	Wire Reinforced Steel In Tension	32
3.6	Section 'A-A' Through Wire Reinforcement.	32
3.8	Average Values Of Modulus Of Elasticity For Different Mixes	38
3.9	Direct Tension Tests	39
3.10	Direct Tension Tests	40
3.11	Direct Tension Tests	41
3.12	Direct Tension Tests	42
3.13	Variation Of Modulus Of Elasticity With Fibre Content	45

<u>FIGURE</u>	<u>TITLE</u>	<u>PAGE</u>
3.14	Variation Of First Crack Stress To W/C Ratio For Different Theoretical Fibre Spacing	46
3.15	Per Cent Relative Increases In Strength With Varying Fibre Cement Ratios for Different W/C Contents.	47
3.16	Average Increases In Strength	48
3.17	Variation In Strength With Theoretical Fibre Spacing	49
3.18	Variation Of First Crack Stress With Respect To Theoretical Fibre Spacing	50
4.1	Sign Convention	54
4.2	Deformation Of A Sandwich Element	54
4.3	Element Of Lower Faces	57
4.4	Testing Under Third-Point Load	60
4.5	Modulus Of Elasticity Of Face Material	64
4.6	Steel Fibre Reinforcement	65
4.7	Faces Steel Fibre Reinforced	66
4.8	Glass Fibre Reinforcement	67
4.9	Glass Fibre Adjusted Deflections And Percentage Of Error	68
4.10	Faces Glass Fibre Reinforced	69

<u>FIGURE</u>	<u>TITLE</u>	<u>PAGE</u>
4.11	Wire Mesh Reinforcement	70
4.12	Wire Mesh Adjusted Deflections and Percentage Of Error	71
4.13	Faces Wire Mesh Reinforced	72
4.14	Summary Of Beam Tests	73
4.15	Element Layout For Beam Finite Element Analysis	77
4.16	Beam Displacements	78
4.17	Section Of The Slab Analyzed	87
4.18	Element Layout For Slab Finite Element Analysis	88
4.19	Plate Displacements	89
4.20	Theoretical And Experimental Displacements	91
4.21	Comparison Of Theoretical And Experimental Principal Stresses	92
4.22	Loading Of The Sandwich Slab	93
A.1.1	Details Of Core Sample Moulds	99
A.1.2	Details Of Face Sample Moulds	100
A.1.3	Details Of Beam Moulds	101
A.1.4	Details Of Slab Mould	102

NOTATIONDESCRIPTION

A	Crack Area
A_0	Average Shear Area
a	Distance From The Supports To The Load
B	Bending Stiffness Of Beam Or Element Of Isotropic Plate Per Unit Run
B_f	Bending Stiffness Of One Face Per Unit Run
B_0	Bending Stiffness Of The Whole Sandwich Section
c	Cement Content By Weight
c	Thickness Of The Core Of A Sandwich Section
d	Diameter Of Fibre
E	Modulus Of Elasticity
E_f	Modulus Of Elasticity Of The Isotropic Faces
E Fibre	Modulus Of Elasticity Of The Fibres
f	Fibre Content By Weight
f	Thickness Of A Face Of A Sandwich Section
G	Rate Of Release Of Elastic Energy
G_0	Modulus Of Rigidity Of The Core
I	Moment Of Inertia
K	Stress Intensity Factor
K	$\frac{W_m}{W_m + W_a}$
K_f	Stress Intensity Factor Due To Rivet Pinching Forces
K_T	Total Stress Intensity Factor
K_σ	Stress Intensity Factor Due To Remote Stress

NOTATIONDESCRIPTION

K_F'	K_F In Three Dimensional Solid
K_T'	K_T In Three Dimensional Solid
K_s'	K_s In Three Dimensional Solid
L	Span
L	Length of Wire
M	Bending Moment
M_f	Bending Moment In The Faces
N	Number of Fibres At a Cross Section
N_f	Normal Force In The Faces
n	Number of Centroids Per Unit Area
n_w	Number of Wires At a Cross Section
P	Load
P_w crit.	Critical Fibre Content By Weight
p	Total Percentage Of Steel
Q	Transverse Shear Force
S	Transverse Shear Stiffness of Sandwich Section Per Unit Run
S_o	Average Theoretical Spacing of Fibres
S_{c_e}	Effective Average Theoretical Spacing of Fibres
T_o	Core Shear Stress
U	Stored Strain Energy
V	Volume
V_o	Volume of Concrete
V_f	Volume of Fibres
V_s	Volume of Steel
W	Work

NOTATIONDESCRIPTION

w		Water Content By Weight
w_a		Weight of Aggregate Fraction
w_b		Bending Deflection
w_c		Weight of Concrete
w_f		Weight of Total Fibres
w_m		Weight of Mortar Fraction
w_s		Shear Deflection
Δ_L		Deflection Under Load
Δ_{MS}		Midspan Deflection
δ_{bl}		Bending Deflection Under Load
δ_{bm}		Midspan Bending Deflection
δ_{b_1}	=	δ_{bL}
δ_{b_2}	=	δ_M
δ_V		Shear Deflection
δ_{VL}		Shear Deflection Under Load
δ_{VL}		Midspan Shear Deflection
δ_Δ		Difference In Deflection Under The Load And Midspan In Four-Point Load Test
ϵ_1, ϵ_2		Principal Strains
ϕ		$\frac{\rho_f}{\rho_o}$
ϕ		Total Curvature

NOTATIONDESCRIPTION

ν	Poisson's Ratio
γ	Transverse Shear Strain
γ_0	Transverse Core Shear Strain
ρ_c	Density Of Concrete
ρ_f	Density Of Fibres
σ	Overall Plate Stress
σ_1, σ_2	Principal Stresses

SUMMARY

This project is concerned with the possibility of utilising cement in the construction of sandwich beams and slabs.

A method was devised to pour the lightweight core with expanded polystyrene and cement paste. A model investigation is undertaken to find the structural properties of the matrix and to investigate the effects of varying the water-content.

For the faces of the sandwich, fibre reinforcement is used. Investigations have been done to see effects of the variation in reinforcement and the water content on the engineering properties of the section. Formulas relating theoretical fibre spacing are rearranged and relative densities of different fibres to binders are calculated.

The last part of the project is mainly the construction of the sandwich beams and slabs on a larger scale to see the practicability of the methods devised and to check the values that have been found in the earlier parts of the project with the aid of finite element analysis.

CHAPTER 1

HISTORICAL BACKGROUND

The Egyptians were perhaps the first to use the principles of sandwich construction many centuries before Christ. Egyptians used a method of splicing strong wood on the exterior of inferior wood to obtain stronger members. There is also evidence that the Germans used laminated steel in their armour as early as the fifteenth century. In Britain the earliest example of structural sandwich unit was during the construction of Britannia Bridge in 1846, in North Wales. Sandwich panels made of iron sheets and wood core were designed by Robert Stephenson for compression. (Ref. No. 1)

The greatest boost to structural sandwich design construction came during the Second World War for the aircraft industry. Mass produced 'Mosquito Bombers' had a sandwich plywood-balsa fuselage and wings. Radar industry has also benefited from sandwich panels. The stiff dome-like shields were made from non-metal faced cellular rubber honeycombs and foamed plastics. (Ref. No. 2). Some other examples of domes can be listed as the hundred and forty feet diameter American Ballistic Missile Early Warning System, which is made of honeycomb sandwich construction with basic skin thickness of 0.042 inches and of Kraft paper core 6 inches thick. (Ref. No. 3). Also Forest Products Laboratory in the United States shows efforts in the use of structural timber efficiently as sandwich units.

In the late Fifties sandwich panels started to appear in building construction for experimenting purposes. The Monsanto "House

of the Future" in 1956 was a prefabricated shell made as a laminated sandwich panel with a four inch honeycomb core and glass fibre reinforced polyester faces. Even though this was a structural success, it could not compete economically with traditional building techniques at that time. In France 'Salon Des Arts Managers De Paris' built an all-plastics prefabricated panelised system house that weighed only eighteen hundred pounds and had six thousand cubic feet of useful volume. (Ref. No.4). In 1958 a house in Germany was built for Stuttgart Exhibition with sandwich units made of aluminum facing and plastic foam core. In Russia, Italy, and Belgium there are also examples of these kinds of houses.

The mathematical analysis of sandwich panels have attracted attention in research communities as well. "The early work of Argyris, Zienkiewicz, and Clough made it clear that finite element analysis must be the first choice in selecting a technique of numerical analysis to deal with polyhedral sandwich structures,... Reissner and later Green reintroduced the shear component in plate analysis, and notably accepted the viability of a linear variation in shear stress in a sandwich plate work was later extended by Reissner and others." (Ref. No.5). Then Sander investigated the effects at joints between panels, and Abel and Popov included shear in the faces." (Ref. No.5). Now a more or less complete mathematical analysis of sandwich panels is possible with research work done in this field. (For other investigations done see Reference No.5).

In the past years, little attention has been paid to the possible

use of concrete in sandwich construction partly due to the undesirable properties of the weak core and the ease of mass production could not be achieved in field practice. Since due to highly advanced technology in the recent years, the properties of the lightweight aggregates have been considerably improved and the use of precast lightweight concrete in sandwich construction is now possible.

Cement possesses the advantages of fire resistance, fungus and rodent proofness, relative easiness in preparation, and cheapness, and castability in almost any shape into a form at low cost. It has the disadvantages of bad insulation, high density, poor adhesion, and the long time required to develop full strength. With the idea of mass factory built homes after the last world war, extensive research started into low density and high insulation concrete. Three main methods of making low density concrete have been tried.

- Adding low density mineral aggregates such as "Perlite" or "Vermiculite",
- By pressurizing controlled quantities of air, water, and foaming agent through a foam nozzle into a slurry,
- By blending in organic polymers or inorganic beads.

The first two methods have drawn the attention of the researchers more than the latter one. Most of the work done with the latter method took place in private company research laboratories. (Ref. No.6). In The United States of America Koppers Company produced a lightweight concrete with polystyrene beads patent in 1962. (Ref. No.7). Then Robert Sefton got two different patents in 1965 and 1966 (Ref. No.8 and 9)

by changing the method of mixing the beads in the concrete mix. While Koppers Company was putting the virgin beads in the mix then applying heat and expanding the polystyrene into the voids of the mix, Sefton suggested covering the beads with surface-active additive giving the mix a pourable characteristic. By homogeneously distributing the aggregate phase through the binder phase.

In 1972 Grunman Aerospace Corporation and Ache Chemicals and Insulation Company published the work they have done with polystyrene bead mixed concrete poured as wall panels. Sections are claimed to be inflammable when exposed to 1800° F. heat for thirty minutes, drilled with ordinary carpenter tools, easily nailed or screwed, high degree of heat and sound insulation. (Ref. No.10). With these properties polystyrene bead concrete is expected to have very wide practical applications in the near future.

The structural history of the face material that has been used in this research has also a very recent background. Serious efforts to develop commercial applications for fibre reinforced cement and/or concrete are just a few years old. Application areas in which significant field trials have taken place in The United States, Great Britain, and Western Europe include overlays for bridge decks and pavements, highway and airfield, mining and tunnelling applications, slope stabilization, refractory applications, concrete repairs, industrial floors, and precast concrete products. For these applications experience has been gained mainly with steel, glass, and polypropylene fibres as reinforcement. (Ref. No.11).

Although fibre reinforced cement/concrete is not a new idea, within the last fifteen years or so, serious consideration has been given to the use of fibres to improve the engineering properties of moldable construction materials. The results of research work on steel fibre reinforced concrete were first reported in the early Sixties by Romualdi. Serious efforts to study the material in commercial products and applications began in earnest in 1971 in The United States. Similar efforts in England and Western Europe shortly followed this lead. (Ref. No.11).

In The United States main interest has been in the mass concrete applications, while in Western Europe and England interest has been in precast applications as well as mass concrete applications, but the overall activity is less than in The United States. (Ref. No.11).

In areas of interest, there is considerable amount of work done in theories of fibre concrete/cement and properties and testing of concrete/cement containing fibres. While in the U.S.A. Argon and Shack were studying the computing of stresses in and around cylindrical fibres, in England Hale studied the fibre pullout in multiply cracked discontinuous fibre composites. The earlier work of Romualdi and Mandel was mainly the study of the matrix as a whole and changes in the behaviour of the matrix by introducing fibres. He introduced the concept of 'Fracture Arrest.' (Ref. No.12). Krenchel studied the fibre spacing and specific fibre surface in Denmark and Nair led a research in the mechanics of glass fibre reinforced cement. (Ref. No.11).

The Materials Technology Division of 'The Concrete Society' produced a technical report in July 1973 giving a detailed description of the types and properties of fibres, binder matrices for fibre reinforced-cement systems, production technologies, and real behaviour of composite systems for each type of fibres. They state their objectives in the foreword of their report,

- "1. To promote the useful development and exploitation of fibre-reinforced cement-based materials;
4. To consider and encourage useful research into new fibre-reinforced cement-based systems in terms of their physical and mechanical properties and their possible applications to the building and construction industry;" (Ref. No.13).

As can be seen, fibre-reinforced cement-based composites have been through a period of intense development for a relatively short time and are expected to go much further in the near future. The application work done to date with fibre reinforced cement/concrete has helped to identify several factors concerned with its preparation and properties that need to be considered and improved upon if the full potential of material is to be realized.

1. Users have expressed concern over the longer than normal mix preparation times required for fibre reinforced cement/concrete. This will be overcome as special equipment for handling and mixing fibres becomes available;

2. More formation is needed about fibre balls or clumps during mixing, especially where high fibre content and/or high aspect ratio fibres are used. Again the use of special mixing equipment will overcome this problem;
3. The properties of fibre reinforced cement/concrete in the field have often been inferior to those obtained in the laboratory. This is due, in part at least, to the common practice of increasing the water content of the mix to satisfy the workability requirements of the workmen in the field;
4. Improvements in the bond between fibre and matrix would lead, it is felt, to an improvement in the beneficial effect that the fibres have on the properties of the concrete. (Ref. No.11).

CHAPTER 2
CORE MATERIALS

2.1. Introduction

In this research, in order to keep the parameters as few as possible, the core has been made from expanded beads with cement paste in the voids between the beads, and for the faces of the sandwich, three different kinds of reinforcement have been tried; i) Alkali - resistant glass fibres, ii) Chopped steel fibres, iii) Expanded steel wire mesh.

2.2 The Polystyrene Beads

The commercially available expanded polystyrene beads, called simply beads from now on, usually come in varying diameters, which is a favourable factor in obtaining a lightweight cement. The greater the range of bead sizes available, the more the volume of the pour is occupied with beads.

The varying diameters of the beads occur as a result of the process of obtaining expanded polystyrene, an indirect derivative of crude oil to which has been added an expanding agent so that it can be made into a foam. In summary, the process is as follows :

The liquid styrene monomer is heated in water. As styrene will not mix with water, the suspension is stirred during the heating process and the styrene forms into small globules in the water, thus eventually becoming 'beads'. The effect of the heat

and added catalysts cause the styrene in each globule to polymerise. During this process the expanding agent pentane is pumped into the kettle under pressure. Pentane, which is volatile, will not mix with water, but dissolves into the styrene. The latter subsequently becomes 'polystyrene.' At this stage the beads are formed with pentane locked inside them.

When the water has cooled and the beads have solidified, the water is drained off, the beads centrifuged, and flash-dried, and the result is expandable polystyrene beads. When the beads are heated in steam, the polystyrene softens, the pentane tries to escape and in so doing, the beads expand forming thousands of tiny cells within each bead. It is these cells that hold dead air making expanded polystyrene a good thermal insulator. In this process original beads increase in size by approximately three times. (Ref. No.6).

The beads used in this research are supplied by Vencil Resil Limited. The diameters vary from 3mm. to 7mm. at $\frac{1}{2}$ mm. intervals. The cement used is an ordinary rapid hardening Portland cement.

2.3. Pouring of Test Samples.

Expanded polystyrene beads provide a form of aggregate of discrete closed cell particles which should be distributed homogeneously within the cement binder. The ratio of expanded beads to cement ultimately determines density, which in turn, determines the extent of thermal conductivity. In this research thermal conductivity of the test samples have not been measured.

In pouring the samples a different approach has been tried to achieve homogeneity and minimum density and therefore minimum thermal conductivity. (For other methods see Section 4.3). Since the beads have a density of the order of one hundredth of that of cement paste, to achieve a homogeneous mix by ordinary pouring methods is practically impossible. Besides, the particles are not easily wetted by water and indeed, are substantially impervious to moisture. The cement itself does not bond with beads, but when cement is in the form of wet paste a small adhesion between the beads and the paste is possible. In other words wet cement acts like a surface covering agent which helps to increase the density of the beads to a certain extent.

The purpose of the beads is to ensure controlled quantity of voids in the test beam, rather than acting like an aggregate due to the very poor adhesive characteristic of dry cement paste to polystyrene. Since it is the desirable property of the sandwich core to be of low density, the maximum volume of the pour has to be filled with beads rather than cement paste. To achieve this condition the molds are first filled with beads to find the maximum possible amount of beads which can be required. At this stage the beads are affected, due to very low density, by minute amounts of force fields around, such as static electricity on the clothes of the experimenter or small movements of air around the molds. In case of vibrating the molds at this stage most of the beads pour out of the molds. Therefore to increase the density of the beads and to put them in a workable form one takes advantage

of the weak adhesive property of the wet cement paste. The beads in the molds are transferred into a mixing bowl and mixed with water and cement keeping the water/cement ratio the same as that required for the whole of the mix to keep the sample within controlled parameters. A reasonable surface covering is achieved if it is not possible to observe the original bright white colour of the beads. The amount of cement needed for surface covering is approximately 20% - 30% of the total amount of cement needed for the whole of the beam and can be found by trial and error.

The beads are transferred to the molds and by tamping can be fitted homogeneously into the mold. Filling the voids between the beads can be done properly only by experience. The most important factor is the water/cement ratio of the paste to be poured onto the beads. If the water/cement ratio is high the strength of the mix is low, from ordinary cement characteristics; but it is easier and more possible to get a more rigid beam due to easy penetration of the cement paste in all possible voids between the beads and vice versa. An optimum water/cement ratio is found by trial and error (See Figure 2.2).

To ensure a reasonable flow, the paste has to be nearer to the liquid form than to the solid form, but for lower water/cement ratios filling the voids layer by layer is advisable, minimum layer thickness being the biggest diameter of the bead, but from time consuming and practical points of view this is undesirable.

Once the paste is ready to pour into a mold, a greased plank with dimensions equal to length and width of the mold has to be available to hold the beads in place. During vibration the large difference in density between beads and cement paste and the poor adhesion of cement paste to beads can result in the cement paste sinking to the bottom and the beads rising to the top.

In this research the paste is poured on top of the beads, and then a plank of which the lower face is greased, is placed on top and held by clamps. The mold is vibrated for about half a minute. The screws of the clamps have to be tightened as frequently as possible because they tend to loosen due to vibration and due to top layer of cement penetrating downwards. Otherwise the top layer of cement transfers to the bottom of the mold. The above procedure is repeated 2 - 3 times for a depth of the core of 40mm. For deeper beams a different approach has been used. (See section 4-3, Pouring of sandwich beams.)

Since the mix is made using cement paste of very high initial water content, a thin film of water forms on top of the mix after vibration. To get a stronger beam this film has to be removed. A suction is provided by the simple means of placing about 4 - 5 layers of blotting paper on top of the sample. This paper absorbs the film of water and once it is wet it creates a curing medium for the beams. After the beams are hardened in the molds (24 - 30 hours in moist conditions) they are transferred to a temperature controlled curing tank and removed from the tank after six days for

their seventh day strength tests. All samples were 40 x 40mm.

X-section x 500mm. long

2.4. Testing Procedure

To determine the engineering properties, the samples were tested under four point loading. The tests were performed as follows (see Figure 2.1) :

Two steel frames of spans 240 mm. and 440 mm. are used. The smaller span frame is fixed and the larger span frame is connected to the moving crosshead of the Hounsfield 'E Type' Tensometer. The crosshead speed is adjusted to 1mm/sec. so that accurate dial readings can be taken. Dial strain gauges of 0.01mm. reading are placed symmetrically 10mm. away from the supports of the frames and at midspan, making a total of five gauges. The gauges are not placed directly under supports or point of application of loads to avoid the unnecessary measurement of the penetration of the frames into the beams. Then at load increments of 25 Newtons the dial gauge readings are taken. All beams were tested to failure.

2.5. Theory

The four point test is a practical way of determining the elastic and shear modulus of the section, where deflections due to shear cannot be ignored. The deflections are measured at midspan where there is no shear and at points of applied loads, where there are deflections due to shear coupled with bending. Of course, the self weight of beam is neglected. Only applied loads are considered.

Movable Supports

General Arrangement

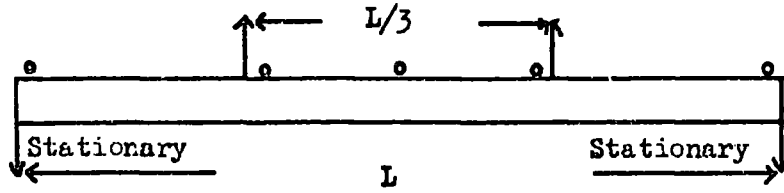

• Dial Gauge Positions
(a)

Beam Deflection

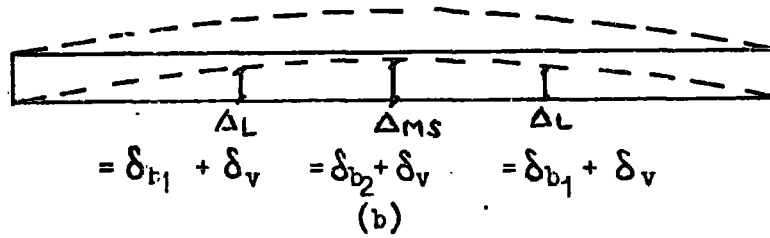

Shear Diagram

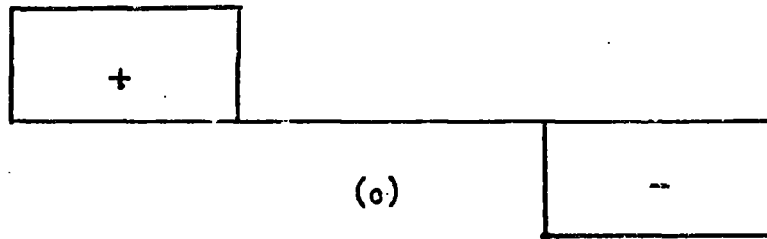

Moment Diagram

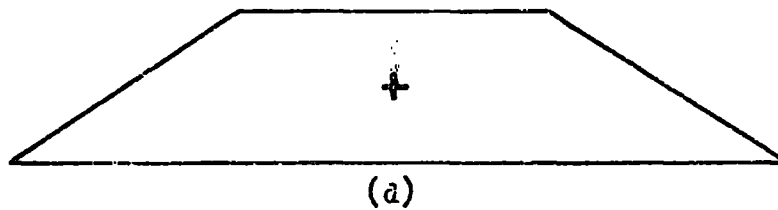

FIGURE 2.1 - Four Point Test.

In mathematical terms:-

$$\Delta_L = \delta_{b_L} + \delta_{V_L} \quad (1)$$

$$\Delta_{MS} = \delta_{b_m} + \delta_{V_m} \quad (2)$$

$$\delta_{V_L} = \delta_{V_m} \quad (3)$$

Only bending moment deflections are obtained under conditions prevailing in the midspan section, the shear deflections here are zero. This gives equation (3).

$$\delta\Delta = \Delta_{MS} - \Delta_L = \delta_{b_2} - \delta_{b_1} \quad (4)$$

From moment-area theorems δ_{b_2} and δ_{b_1} can be calculated in terms of E.

$$\delta_{b_1} = \frac{Pa^2}{EI} \left(\frac{2a}{3} - \frac{L}{2} \right)$$

$$\delta_{b_2} = \frac{PL^3}{EI} \left(\frac{3a}{4L} - \left(\frac{a}{L} \right)^3 \right)$$

$$\delta_V = \frac{Va}{A_e G_c}$$

$$A_e = \frac{\text{Total shear stress}}{\text{Shear stress at neutral axis}}$$

$$\approx \frac{2}{3} \text{ Total X-section area}$$

2.6. Density Measurements

The density measurements are done on a dry basis. All samples were stored in an oven, at 70° Centigrade, for 48 hours to dry the samples. As soon as they were removed from the oven they were weighed and then covered with a very thin film of wax to stop them absorbing water. Then by water displacement method the volumes were measured, giving density.

$$\rho = \frac{W_{\text{Dry}}}{\text{Volume}}$$

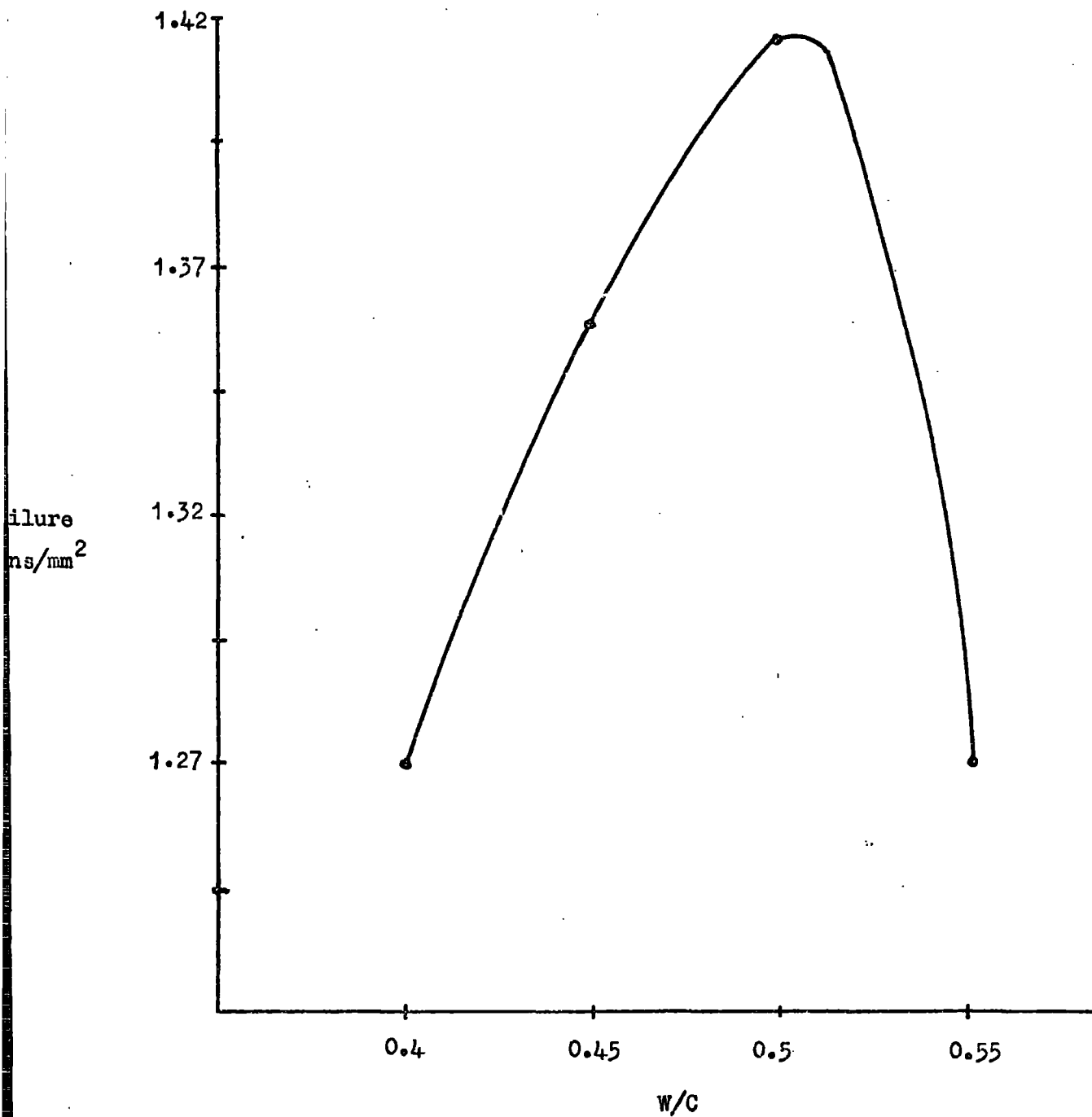

FIGURE 2.2 - Approximation of Failure Stress
in Relationship to Water-
Cement Content.

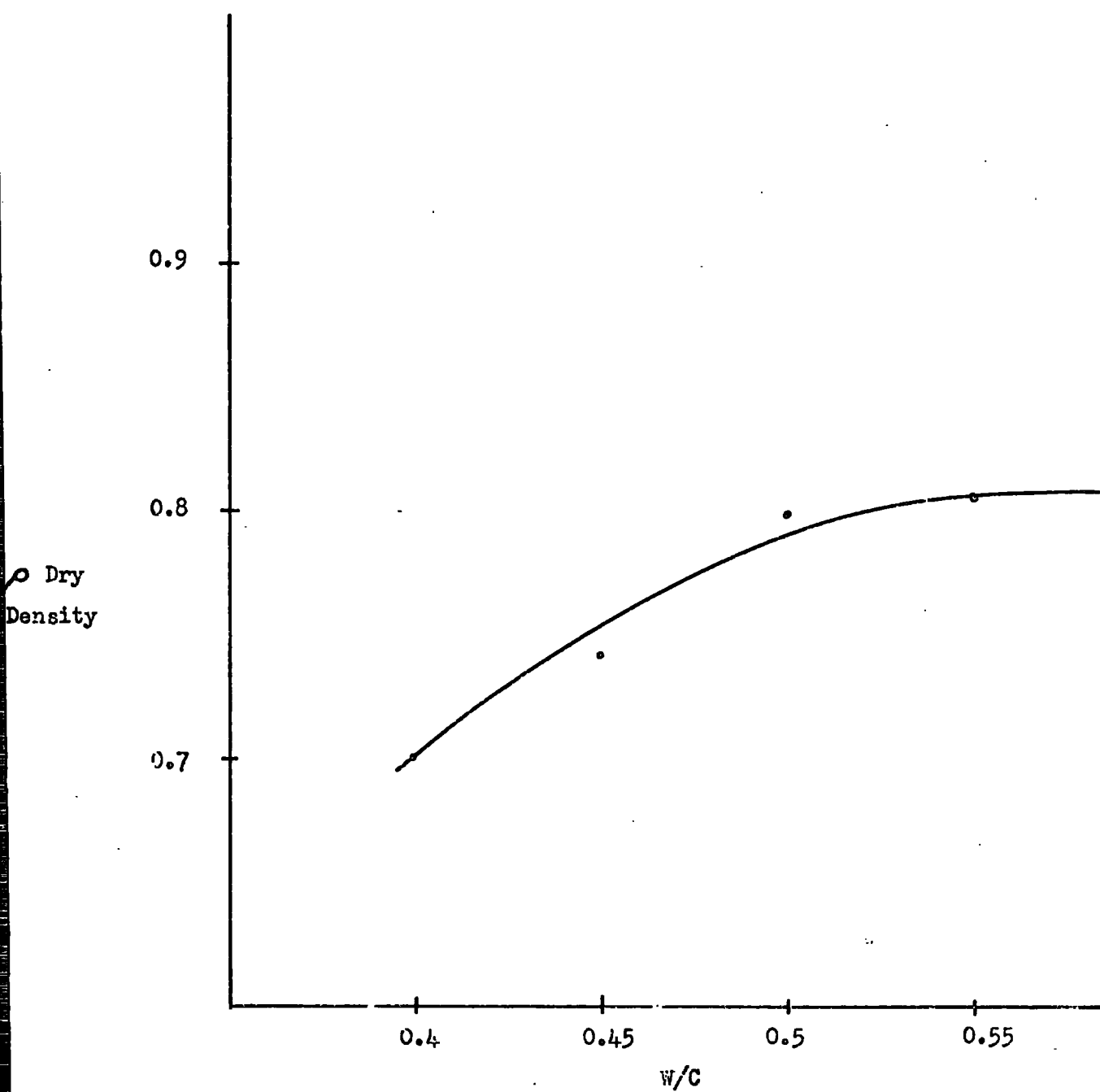

FIGURE 2.3 - Effect of Water-Cement Ratio
on Density.

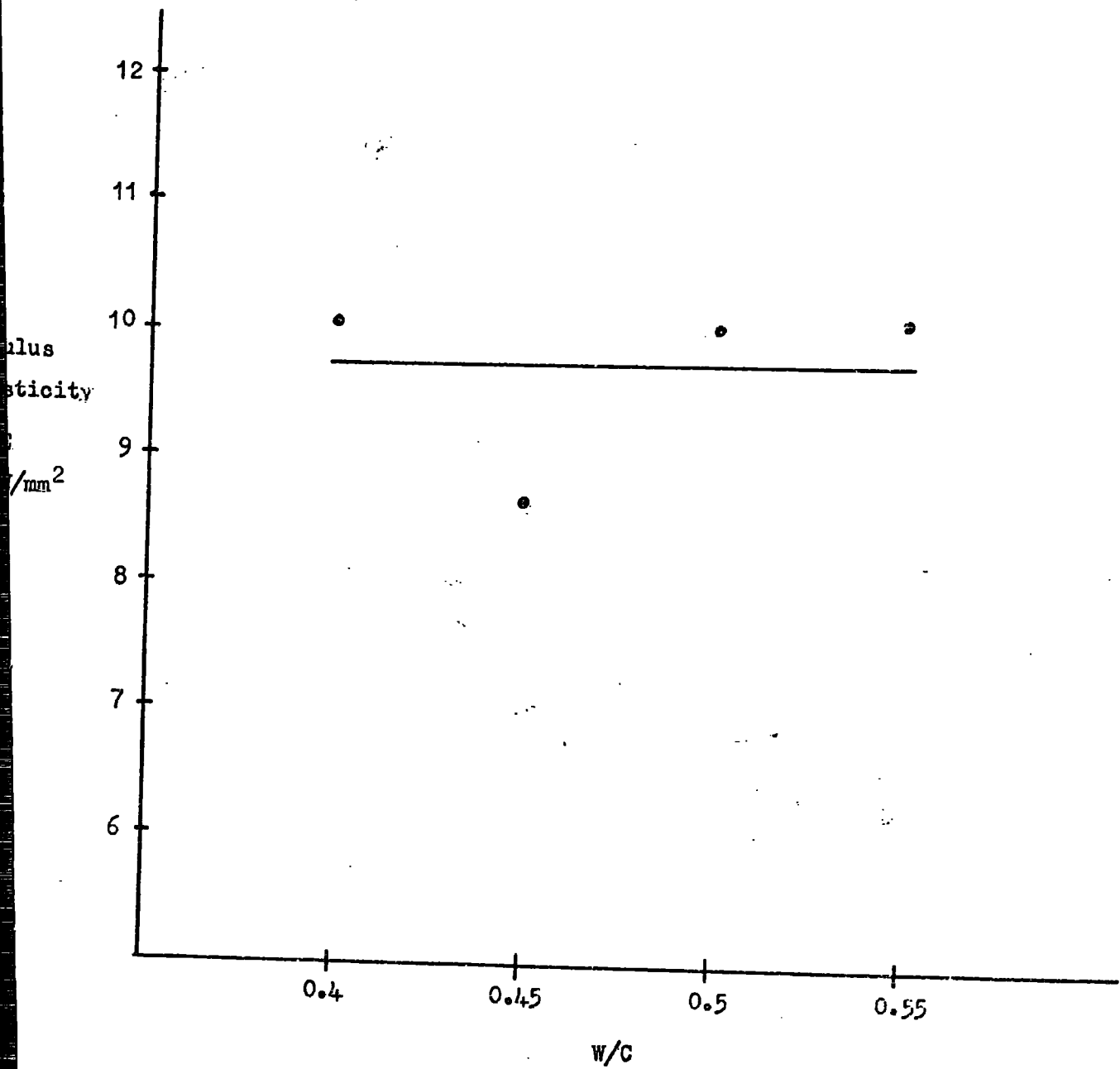

FIGURE 2.4 - Approximation of Modulus of Elasticity.

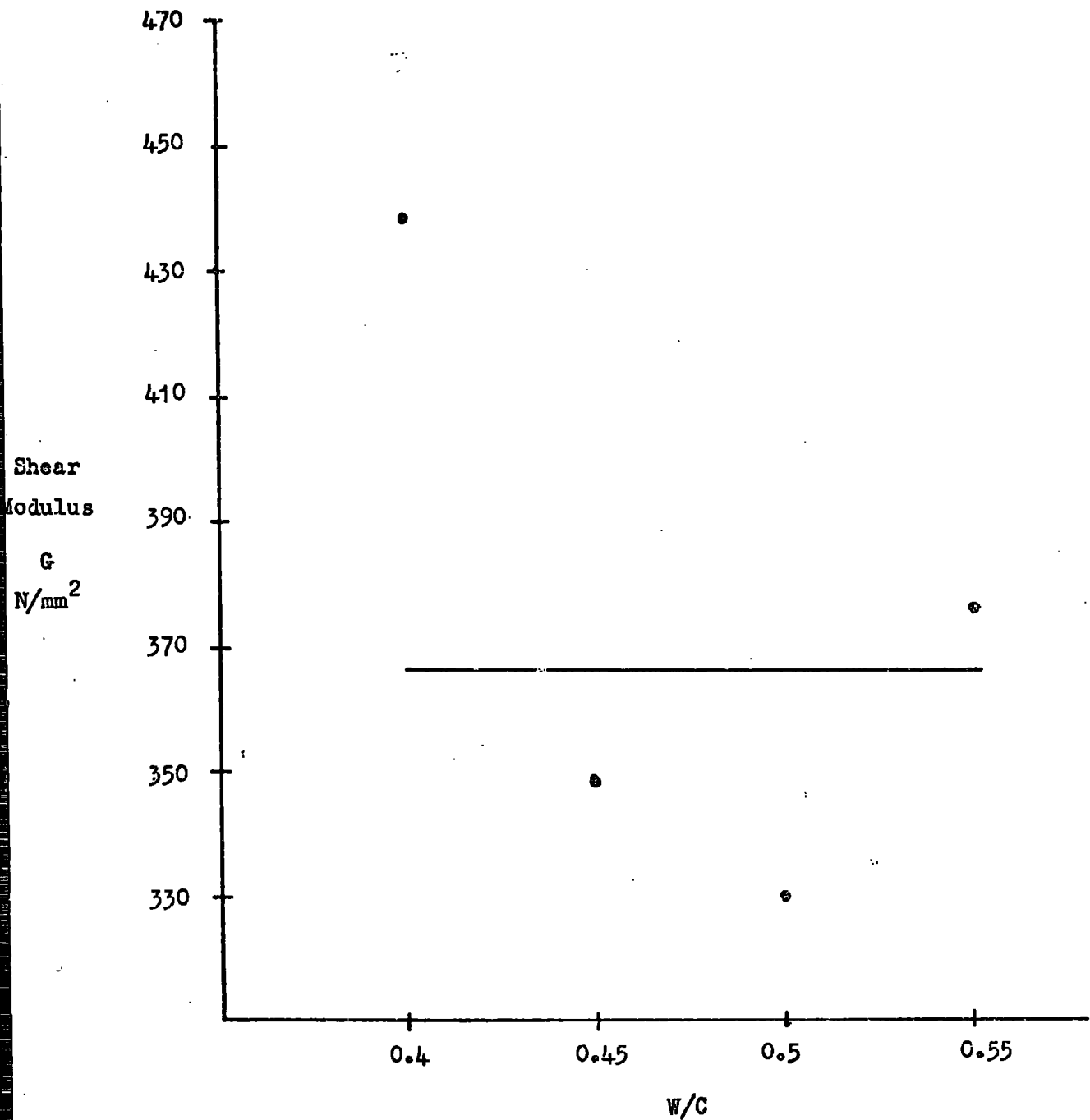

FIGURE 2.5 - Approximation of Shear Modulus.

2.7. Discussions

The density versus water-cement ratio graph (see Fig. 2.3) gave the expected result. In a given volume only a maximum amount of beads of certain diameters can be fitted, assuming the beads are incompressible. Since the volume of voids between the beads is constant, the amount of paste to be fitted in the voids is also constant. Therefore the only factor that determines the density is the capability of the paste to flow into the existing voids. In case of cement paste and the technique used in this research, the water content determines the density of the samples. After a certain amount of water-cement ratio, which is around 0.5, gives the maximum possible density of the samples.

Fig. 2.2 shows the variation of the strength versus water-cement ratio. Since density, and therefore the rigidity strength of the sample, increases with water-cement ratio, the failure stress increases with water content of the mix, but water content has a negative effect on the strength of the mix which is shown on Fig. 2.2 after passing the water-cement content of 0.5.

The calculated Youngs' modulus and shear modulus are approximated as a straight line as shown on Figures 2.4, 2.5, because it was felt a relationship in terms of a curve will be unrepresentative, but a constant value occurs in both cases within the experimental error limits.

CHAPTER 3

FIBRE REINFORCEMENT IN CEMENT

3.1 Introduction

The poor tensile strength characteristic of cement requires some sort of tensile reinforcement for parts of the section that are in direct and/or bending tension. The membrane-like thickness of the faces which are assumed to carry all the flexural stresses in tension and in compression, forced the worker to use an unconventional type of reinforcement, thin enough to be buried in the thickness of the faces properly. Two main types of reinforcement were found suitable for sandwich sections with thin faces - fibres and mesh. The sandwich beams and panels that are tested in this research project are reinforced with two types of fibres; alkali resistant glass and steel fibres, and one type of expanded steel wire mesh supplied by Expamet Industrial Products Limited of Hartlepool.

To understand the behaviour of fibres, tension tests have been carried out with only steel fibres with increasing fibre content for a given volume of cement and water, and for a fixed amount of cement and fibre but varying water content.

There are three reasons for ensuring that the fibres are completely embedded in the cement matrix;

- (i) fire resistance,
- (ii) the avoidance of chemical deterioration and weathering,
- (iii) the achievement of a satisfactory bond between fibre and matrix.

The last is seen as the most important factor for the laboratory specimens used in this investigation. The pulling of fibres from the matrix rather than failure of fibres has been observed in all

of the tensile test specimens.

Independent tests are carried with glass fibre and wire mesh reinforcement to determine the Youngs' Modulus values on tensometer. These values are checked under third point loading in Section 4.

3.2 Theoretical Considerations of Strength for Fibre Reinforcement

From the investigations of other workers the effectiveness of fibre reinforcement depends on the following factors: (see Ref.No.15)

- (i) Modular ratio; Modulus of elasticity of fibre/modulus of elasticity of the matrix,
- (ii) Fibre aspect ratio; length of fibre/diameter of fibre,
- (iii) Fibre orientation with respect to direction of stress,
- (iv) Fibre content.

Theoretically speaking, increase in the above factors should increase the strength of the cement composite for a fixed water/cement ratio.

Since the first two of these factors are relatively self-explanatory, more emphasis has been given to the last two. Fibre orientation is one of the most uncertain factors since the processes of mixing and placing in the mould can arrange the fibres to lie at any angle to three principle direction axes within the matrix. This is represented in Figure 3.1. Therefore, in the calculation of the resistance of the material to any one directional stress or load a correction factor that takes account of the fibre orientation should be introduced. The uncertainty of this correction factor has to be remembered in all design consideration. This has to be

reflected by the safety factor or in the load factor for design conditions

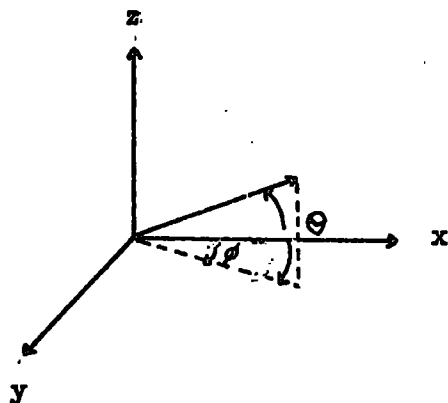

Figure 3.1 - Orientation of a Random Fibre

A correction factor can be obtained assuming; 1) the stress is parallel to one axis (x), 2) the ratio of the average of the projected lengths in one direction to the total length is a true measure of the effectiveness of the fibre on that axis, 3) effective projection in the X direction of N wires is given by Equation 1.

$$\frac{N \int_0^{\pi/2} \int_0^{\pi/2} L \cos.\theta \cos.\phi \, d\theta \, d\phi}{N \pi/2 \times \pi/2} = 0.41 L \text{ (Equation 1)}$$

Then in a given volume the average theoretical spacing Sc , distance between geometric centre of effective wires, of N wires is

$$Sc = 3 \sqrt{\frac{V}{N}} \quad (2)$$

thus $Sc_e = 3 \sqrt{\frac{V}{(0.41N)}} \quad (3)$

Equation three arises because the wires in any direction are 41 per cent effective, Sc_e being the effective fibre spacing.

The number of centroids per unit area of any cross-section is given by

$$n = \left(\frac{1}{Sce} \right)^2 \quad (4)$$

Assuming the length of the wires to be greater than Sce , as will usually be the case, the wires will extend into cross-sections previously allocated to other wires. This will create an overlapping, thus increasing the number of wires through any cross-section by the factor L/Sce . The number of wires n_w at a cross-section is then -

$$n_w = \left(\frac{1}{Sce} \right)^2 \frac{L}{Sce} = \frac{L}{Sce^3} \quad (5)$$

or, substituting equation (3) in (5) -

$$n_w = \frac{0.41 NL}{V} \quad (6)$$

The average spacing of the wires is then -

$$S = \frac{1}{V n_w} = \sqrt{\frac{V}{0.41 NL}} \quad (7)$$

The average spacing of the effective wires can be expressed in terms of wire diameter 'd' and total percentage of steel 'p'. The total volume of steel 'Vs' in a volume of reinforced concrete 'V' is -

$$V_s = \frac{pV}{100} \quad (8)$$

The volume of steel in each wire is $\pi d^2 L/4$ and the number of wires is then -

$$N = \frac{4V_s}{\pi d^2 L} \quad (9)$$

and, from equation (8) -

$$N = \frac{pV}{25 \pi d^2 L} \quad (10)$$

Substituting (10) in (7) yields -

$$S = 13.8d \sqrt{\frac{(1)}{(p)}} \quad (11)$$

(Reference No.14)

Since it is more accurate and easier to measure percentages in terms of weight the above equation is modified to be expressed in terms of weight -

$$\text{Taking } p = \frac{V_f}{V_o + V_f} \times 100 \quad (12a)$$

$$= \frac{\frac{W_f}{\rho_f}}{\frac{W_o}{\rho_o} + \frac{W_f}{\rho_f}} \times 100 \quad (12b)$$

$$= \frac{100}{\frac{W_o}{W_f} \frac{\rho_f}{\rho_o} + 1} \quad (12c)$$

substituting Equation (12c) in (11) yields -

$$S = 1.38d \sqrt{\left(\frac{W_o}{W_s} \phi + 1\right)} \quad (13)$$

where $\phi = \frac{\text{density of fibre}}{\text{density of binder}}$

values of ϕ for certain fibres are given in Figure 3.2.

Figure 3.2

Density Ratios for Commonly Used Reinforcing
Fibres to Binders.*

MATERIAL	ρ
1. Crystalline Silicates: Chrysotile White Asbestos Crocidolite Blue Asbestos	1.020 3.480
2. Glasses 'E' Glass BRS Glass (Cem-fil)	1.025 1.087
3. Ceramics Alumino-silicate (Kaowool, Fibrefrax) Carbon - Type 1 (Modmor) Carbon - Type 2 (Modmor)	1.104 0.796 0.696
4. Metals High-tensile Steel High-carbon, low-carbon Stainless Steel	3.14
5. Natural Vegetables Cotton Sisal Hemp	0.54 0.592 0.592
6. Polymers Polypropylene Filament or fibrillated Nylon (Type 242) Polyester (Type C Terylene)	0.368 0.455 0.55

* Ordinary Portland Cement

High Alumina Cement

For plaster increase above values by a factor of 1.04.

As expected, decreasing the fibre spacing increases the reinforcement area and therefore should increase the tensile strength of the section. This increase has been studied by other workers (see Reference No.12) and explained by the application of fracture mechanics to concrete strength. The fundamental concept behind these studies is a recognition that the low tensile strength of concrete is due to the propagation of cracks originating as internal flaws. Introduction of fibres into the matrix prevents or retards the initiation of tension cracks and this can be accomplished if the internal flaws are locally restrained and prevented from extending into adjacent material.

James P. Romouldi and Gordon B. Batson explained the simplest example of crack initiation by the stretched flat plate shown in Figure 3.3. It is assumed that heavy grips uniformly transfer load to the plate and that the plate is cut through by a slot of length $2a$. It is further assumed that the fracturing process is of sufficient rapidity that the inertia of the grips prevents their movement. Thus, no energy is added to the system during the fracturing process.

The extension of the crack tips is accompanied by irrecoverable energy losses due to the extension of the plastic zone in the vicinity of the crack tips. The rate of loss of irrecoverable work with respect to area of crack extension is $\frac{\delta W}{\delta A}$ where W is the work to open or extend the crack and A is the crack area. The rate of release of elastic energy is denoted by symbol G and, for the particular system -

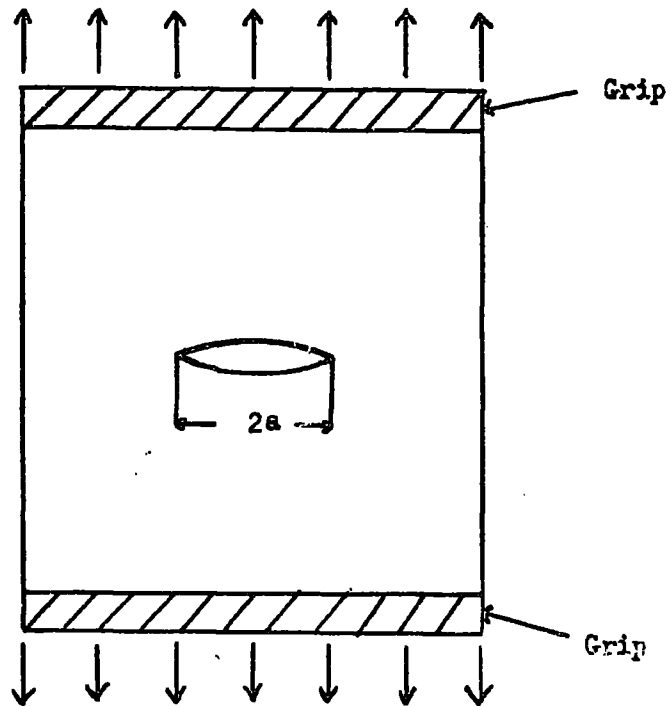

Figure 3.3 - Centrally Notched
Plate in Tension.

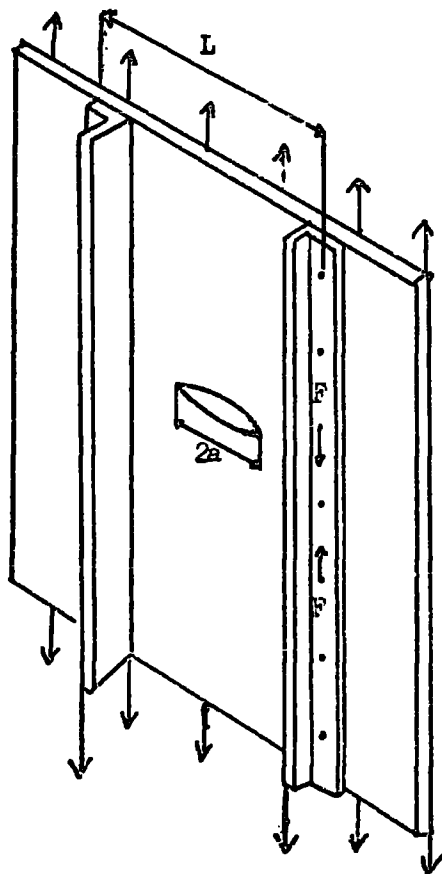

Figure 3.4 - Riveted Stiffener
Crack Arresters.

$$G = \frac{\pi \sigma^2 a}{E} \quad (14)$$

where σ is the overall plate stress and E is the modulus of elasticity.

The criterion for rapid fracture propagation is that the rate of release of elastic energy is equal to or greater than the consumption of energy of the extending crack, or

$$G > \delta W / \delta A \quad (15)$$

The material characteristic $\delta W / \delta A$ may be inferred by a simple test because when a notched plate is loaded and observed for the crack length and stress at failure, a numerical value may be obtained for $\delta W / \delta A$ by substituting the values in equation (14) and comparing to equation (15).

It has been proved that the parameter combining stress near the crack tip and structural geometry is the stress intensity factor K , which is related to G by -

$$K^2 = \frac{E}{\pi} G \quad (16)$$

For the particular geometry of Figure 3.3 the stress intensity factor due to remote stress T is -

$$K \sigma = \sigma \sqrt{a} \quad (17)$$

The crack arrest mechanism may now be illustrated with reference to Figure 3.3. A pair of stiffeners are shown riveted to the plate and are arranged at their extremities remote from the crack in a manner such that they are subjected to the same strain as the plate.

Thus, in the absence of a crack, there will be no tendency for relative motion between the plate and stiffeners in the vicinity of the crack. However, the plate tends to stretch more than the stiffeners, due to the stress singularity at the crack tips. This tendency is resisted by the rivets which exert "pinching" forces in the plate of magnitude F . These forces produce a stress intensity factor K_F which has an opposite sense to the intensity factor due to the plate stress described above. Thus, the total stress intensity factor is given by -

$$K_T = K_\sigma - K_F \quad (18)$$

Thus, for a given critical value of K for the material, fracture occurs at a higher plate stress, due to the reduction by the amount K_F , than would be possible in the absence of the stiffener. (Of course, the rivet must be of sufficient strength to mobilize the pinching force or failure will occur by rivet shear or bearing.)

The parallel to the above described arrest mechanism in the case of reinforced concrete is described with the aid of Figure 3.5. Figure 3.5(a) represents a mass of concrete in tension. The reinforcement consists of a rectangular array of rods at a spacing λ and located parallel to the direction of the tension stress. At some interior location as shown in section in Figure 3.5(b), an internal flaw exists in the form of a flat disc-shaped crack. Assume that the crack is centrally located in a nest of four adjacent reinforcing rods, in a section AA, as shown in Figure 3.6. A similarity to the stiffened plate can be seen. In the absence

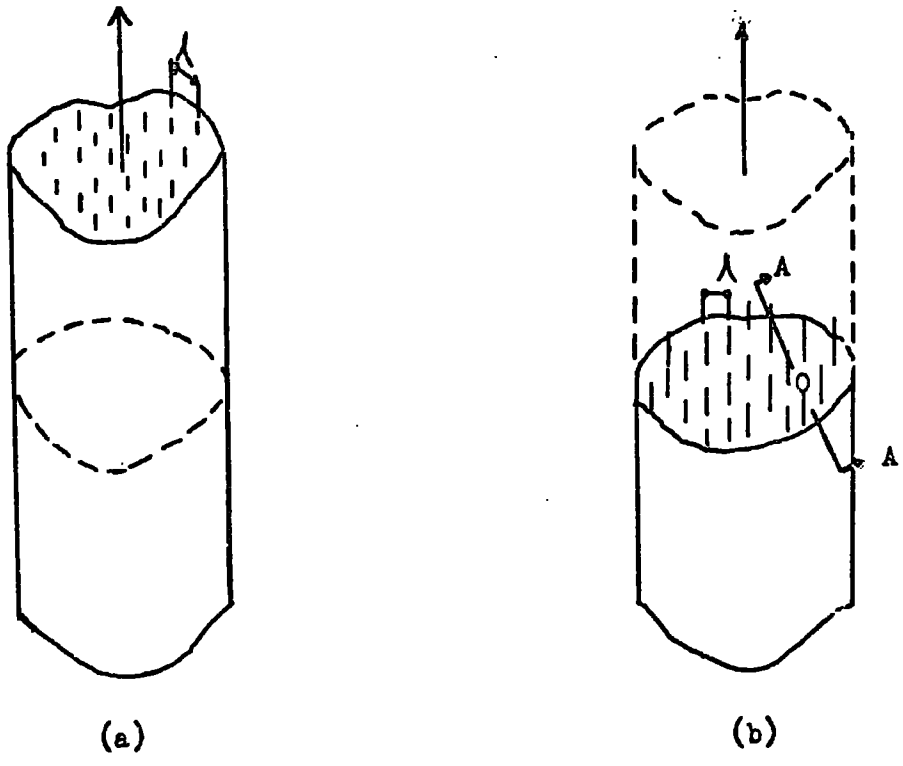

Figure 3.5 Wire Reinforced Concrete in Tension.

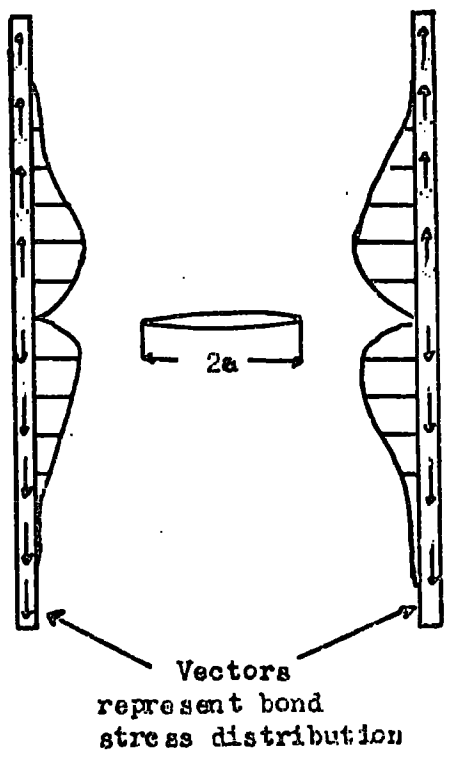

Figure 3.6 Section 'A-A' Through Wire Reinforcement.

of the crack, the steel rods and the concrete are stretched equally, and accordingly, there is no tendency for one to move relative to the other. In the vicinity of the crack edges however, the longitudinal extension due to the stress singularity is resisted by the stiffer rods. The distribution of the bond stress can be shown as in Figure 3.6. In the plane of the crack the bond stress is zero by symmetry and increases to a maximum, and then decreases with increasing distance from the crack edge. As the local extension tendency diminishes the distributed bond stress acts as a series of finite pinching forces each acting in much the same manner as the single rivet pinching force described above. The calculation of the stress intensity factor due to the forces along the four adjacent bars should be similar in every detail to that of a single rivet force in the plane of a plate, and the total intensity factor is given by -

$$K_{\text{T}}' = K_{\sigma}' - K_{\text{F}}' \quad (19)$$

The primes denote that the case refers to a three-dimensional solid.

The spacing and size of the reinforcing rods for effective crack containment must be such that the magnitude of K_{F}' is sufficiently large to cause an effective reduction in K_{T}' . An additional criterion for arrest is of course, that the distributed forces are mobilized and do not exceed the bond strength between the binder and fibres. (Reference No.14)

It is expected that the tensile strength will increase as the

reinforcement spacing is decreased below a certain critical value. This behaviour is verified in Reference No. 14 by increasing fibre quantity. But decreasing diameter to keep percentage constant and the critical fibre spacing is found to be 7mm to 12mm for steel fibres.

Unfortunately some of the workers, including the present author did not achieve such good results as were expected. The length of fibres used was not sufficient to achieve the bond required so that the fibres were never highly enough stressed to stop the matrix from cracking but instead were pulled out of the matrix as the crack enlarged.

Another important factor that determines the strength of the matrix is the workability. Even though increasing the fibre content beyond the critical spacing increases the strength of the section, but addition of fibres also has drastic effects on the workability of the section. Edgington et.al. (Reference No. 16) have formulated an empirical relationship for critical fibre content by weight.

$$P_{\text{Wcrit.}} = 75 \pi \frac{SG_f}{SG_o} \left(K - \frac{d}{L} \right) \quad (20)$$

d = fibre diameter

L = fibre length

$$\frac{SG_f}{SG_o} = \phi \text{ calculated in Figure 3.2.}$$

$$K = \frac{W_m}{W_m + W_a}$$

W_m = Weight of mortar fraction
(particle size < 5mm)

W_a = Weight of aggregate fraction
(particle size > 5mm)

Calculated P_w = 4.44 per cent in this research $K = 1$

A possible way to design the fibre reinforcement can be as follows :

$$\sigma_{\text{Design}} = E_{\text{fibre}} \frac{\epsilon_{\text{crack matrix}}}{\text{S.F.}} \quad (21)$$

S.F. = Safety factor

Where effective area for design stress depends upon theoretical fibre spacing. The reason that strain of matrix is chosen as criterion is because the cement or concrete matrix has a lower failure strain than the fibre, i.e. 0.02 per cent as opposed to 2 per cent for glass, 3 - 4 per cent for steel. Thus it is the matrix which cracks first, leaving the fibres to span the crack and carry the load assuming enough bond is achieved between the fibres and matrix. For effective reinforcement the fibres alone must be able to carry the load taken by the cement mix just before it cracked. The volume fraction of fibres necessary for this is, of course, limited by the fabrication and compaction techniques.

3.3 Laboratory Procedures

The aim of these tests is to see the variation of the structural properties of the matrix by varying the fibre content and water cement ratio. To see these variations: only steel fibres of aspect ratio of 17 were used in different percentages by weight, in varying water-cement ratio mixes. (Note that rapid hardening cement was used throughout.)

Samples of 50 x 10 mm. cross-section 500 mm. long were poured in mold-greased, wooden based, steel walled molds and vibrated on an 'Allam' vibrating table, type 230/1/80 between 30 and 45 seconds. The samples are kept in a moist environment for 24 - 30 hours and then transferred to a temperature controlled curing tank to be left there for another six days. Then they were tested in direct tension with an "E-type Hounsfield" Tensometer adjusted for 1mm/sec crosshead movement. Since relative strengths and strains of each sample were important, all the deflections and strengths of the samples were recorded on the tensometer standard equipment.

It has been observed that even though the first crack appears relatively soon, the strength of the sample is not lost, but decreases with fibre pull-out. In other words, the stress-strain curve looks like a parabola.

To by-pass complicated stress concentration calculations for sections with holes, additional reinforcement is required around the tensometer clamp holes of the samples to make sure they fail somewhere in between the holes rather than around the holes, which is more probable due to reduced cross-section with existence of holes. The failure of the full cross-section was achieved in approximately 89 per cent of the samples. There were three samples tested for each kind of mix shown in Figures 3.9-3.11 and only average values are given in the Figure. 3.8.

One of the biggest problems observed was the homogeneous distribution of the reinforcement within the matrix. The fibres have a great

tendency to form 'bird-nest like' bundles in low and high water-cement ratios. If the fibres are to be mixed into the cement without any water, bundles start forming ignoring the presence of the cement. The best water/cement ratio seemed to range between 0.35 - 0.45 to get the best homogeneous mix for a given quantity of fibres. At higher water contents due to the high density of the fibres, these tend to settle at the bottom of the mix and form bundles, leaving the rest of the cross-section unreinforced. In this work it was possible to achieve a reasonable distribution by manual means due to the small size of the samples. This was possible for all water/cement ratios.

Figure 3.8

Average Values Of Modulus Of Elasticity For
Different Mixes

W/C	f/o per cent by weight	E N/mm ²	Crack N/mm ²
0.4	3	2515	1.43
	4	3019	1.76
	5	4402	2.20
	6	5603	2.42
0.45	3	2413	1.02
	4	2815	1.42
	5	3609	1.55
	6	5031	1.72
0.5	3	1936	0.96
	4	2512	1.20
	5	3193	1.38
	6	4300	1.69
0.55	3	1850	0.73
	4	2413	1.07
	5	3100	1.20
	6	4096	1.43

W/C = 0.4

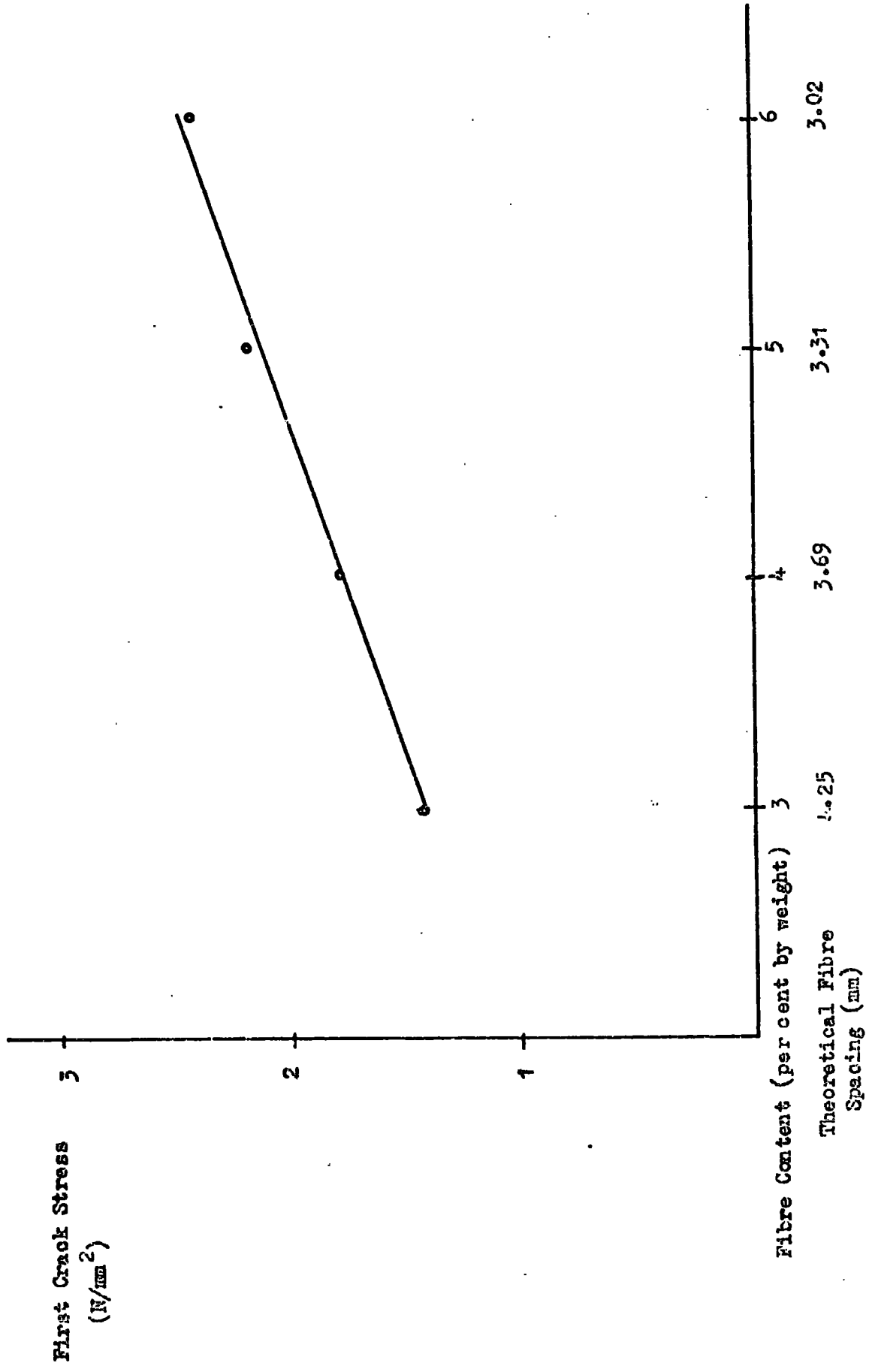

Figure 3.2 - Direct Tension Tests.

W/C = 0.45

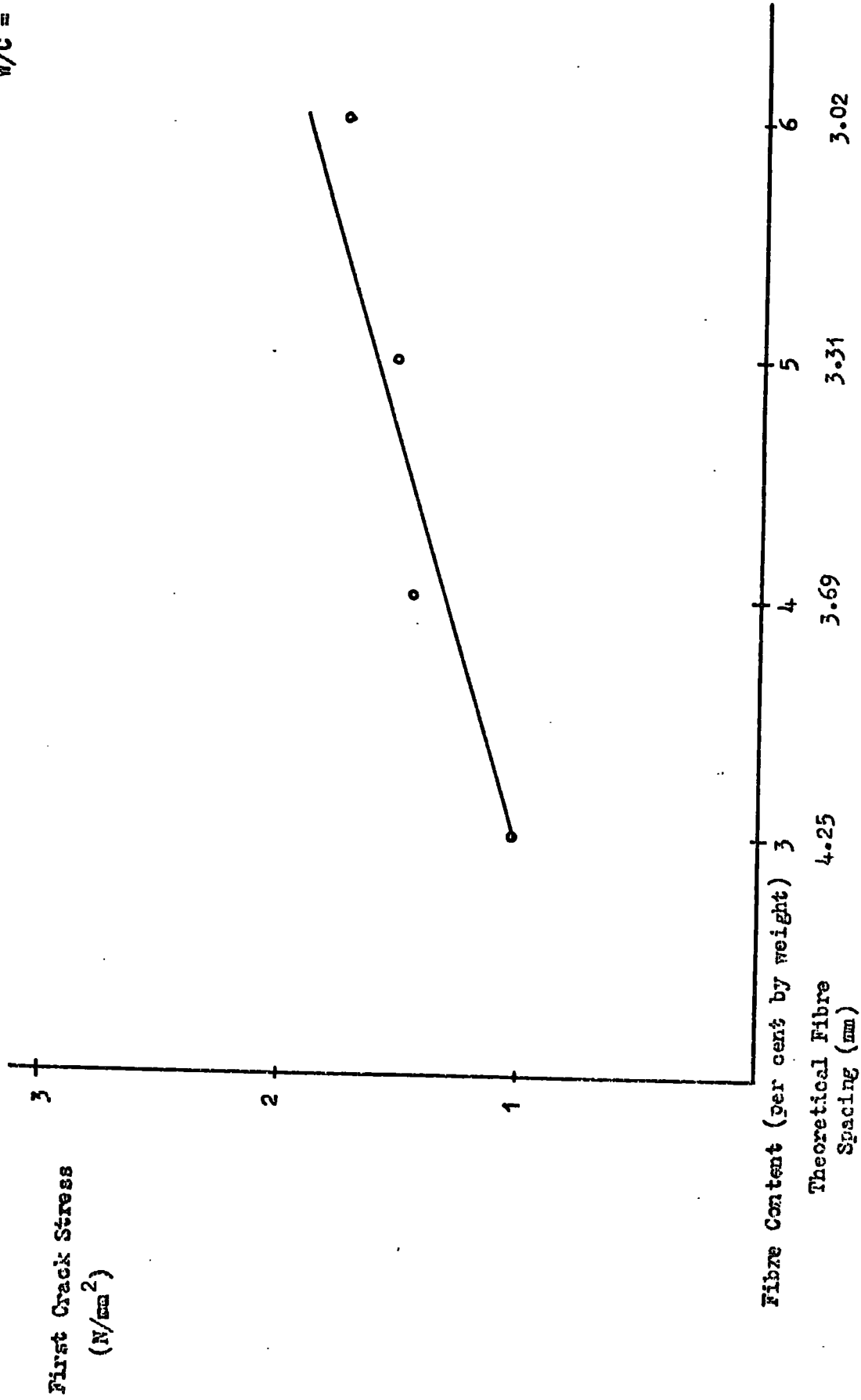

Figure 2.10 - Direct Tension Tests.

First Crack Stress
(N/mm^2)

$w/c = 0.5$

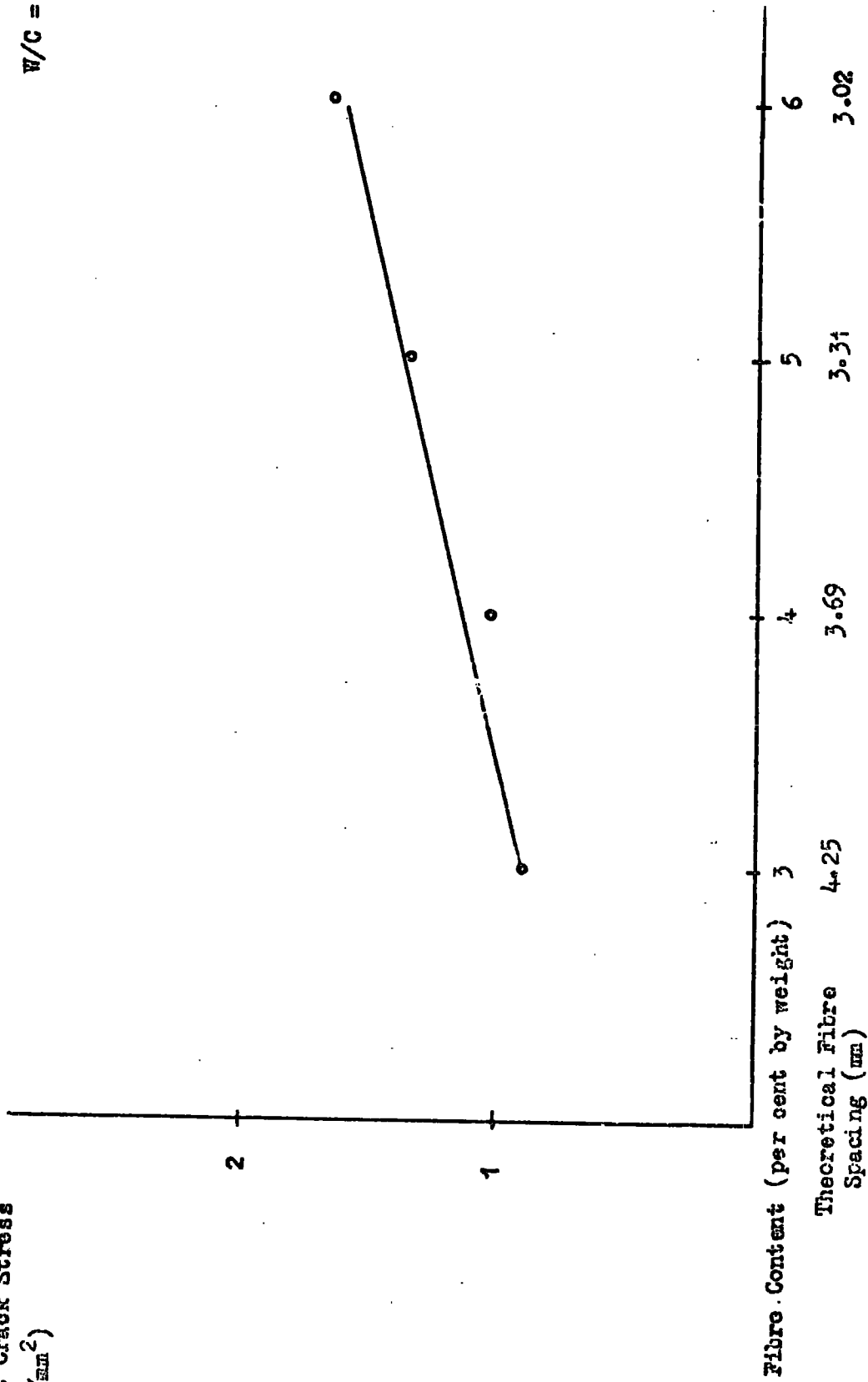
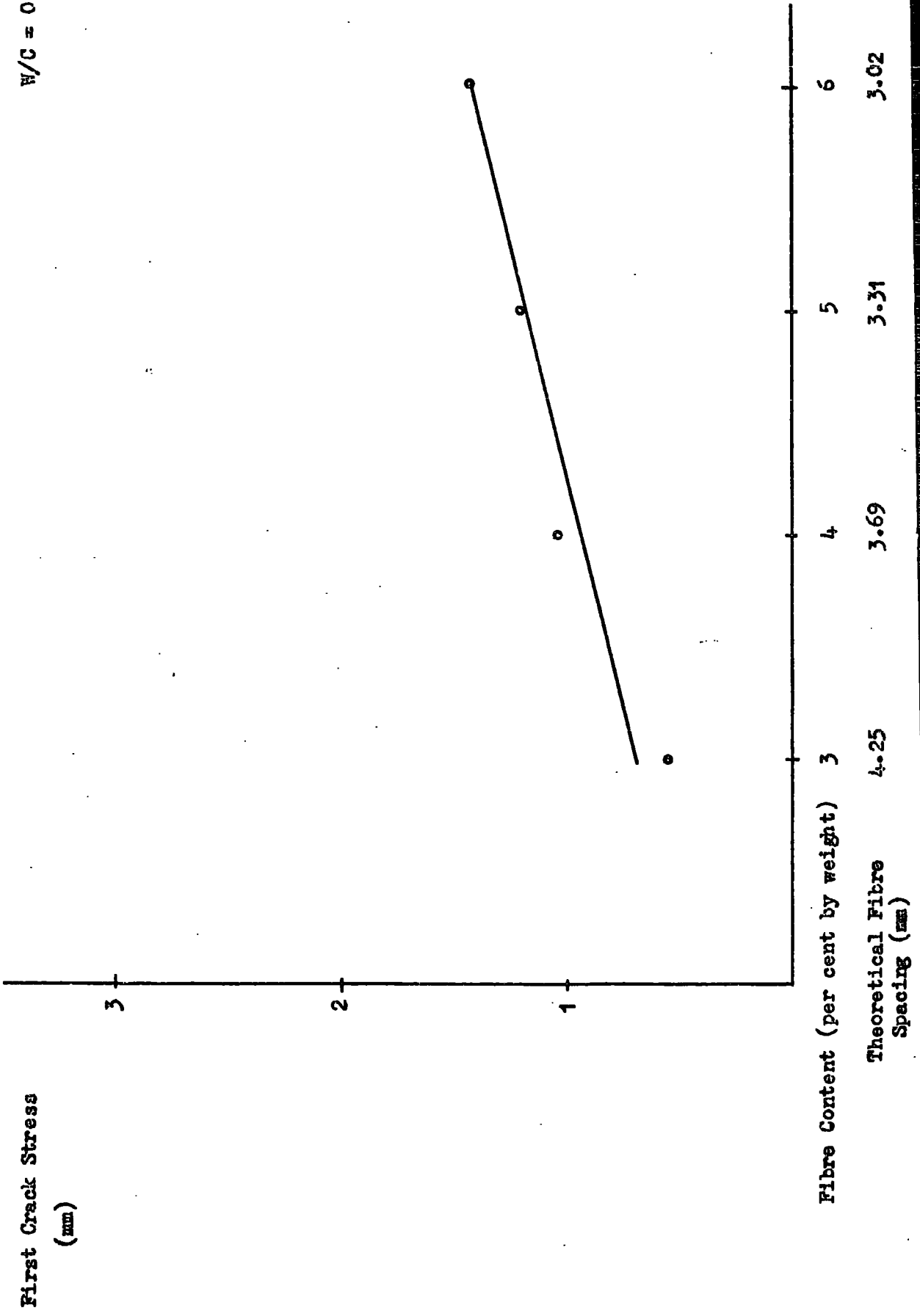

Figure 3.11 - Direct Tension Tests

W/C = 0.55



3.4 Discussion

The tests were designed to achieve the suggested critical fibre spacing by other workers, and observe the improvement on the strength of the section with increasing fibre content. The results are presented in Figure 3.8 and plotted in Figures 3.9 - 3.12 and 3.18.

The improvement in strength can be approximated as a straight line. The relative percentage increases in strength are given in Figures 3.15 - 17. As reinforcement increases, the direct tensile strengths of the sections were increased with increasing fibre content even though this increase in total was not a great amount; but relative increases were considerable. (Figures 3.15, 3.16)

As mentioned in section 3.2, the expected high increases in strength were not recorded. This might be due to decreasing the workability of the matrix by adding vast amounts of fibres, but contrary the Edgington et.al relationship, the strength increases were continued beyond critical percentage. This indicates critical percentage of fibres was greater than calculated in Equation (20), even though K is taken as 1, because there was no aggregate in the samples, which should have given the highest possible critical percentage for the aspect ratio of fibres calculated. But Figure 3.17 shows the smoothening of the approximation curve of percentage increase of strength that workability has an effect on strength at high percentage of fibres in the matrix.

The values of modulus of elasticity for different water/content ratio and different fibre content are plotted in Figure 3.13. An approximately linear increase up to a fibre spacing of 3.31mm is in accordance with strength graphs. A further high jump after fibre spacing of 3.31mm may suggest that a further crack arrest occurs below the fibre spacing of 3.31mm. This means that strains are smaller for higher stresses. In other words, the fibres hold the binder together better, or do not allow the cracks to extend as much as they do in higher fibre spacing. Since it has been observed qualitatively, that failure is mainly a bond failure of fibre to binder, the crack-arrest occurs for a short time while a slowly increasing load is applied, reducing strains; but eventually fibres are pulled out, destroying the crack-stop mechanism. Due to high concentration of fibres bond stress is lower around fibres at higher loads compared to lower fibre content. Lower strains are thought to be due to fibres stopping the minute cracks extending.

The effects of high water content on the matrix can be seen in Figures 3.13 and 3.14. The sudden drop of modulus of elasticity and of strength between 0.4 and 0.5 suggests that water content of the mix should be very closely controlled. Around 0.4 ratio, because the minimum workability in pouring the cement-fibre mix starts above a water/content ratio of 0.35.

Tensile
Young's
Modulus
(10^3 N/mm^2)

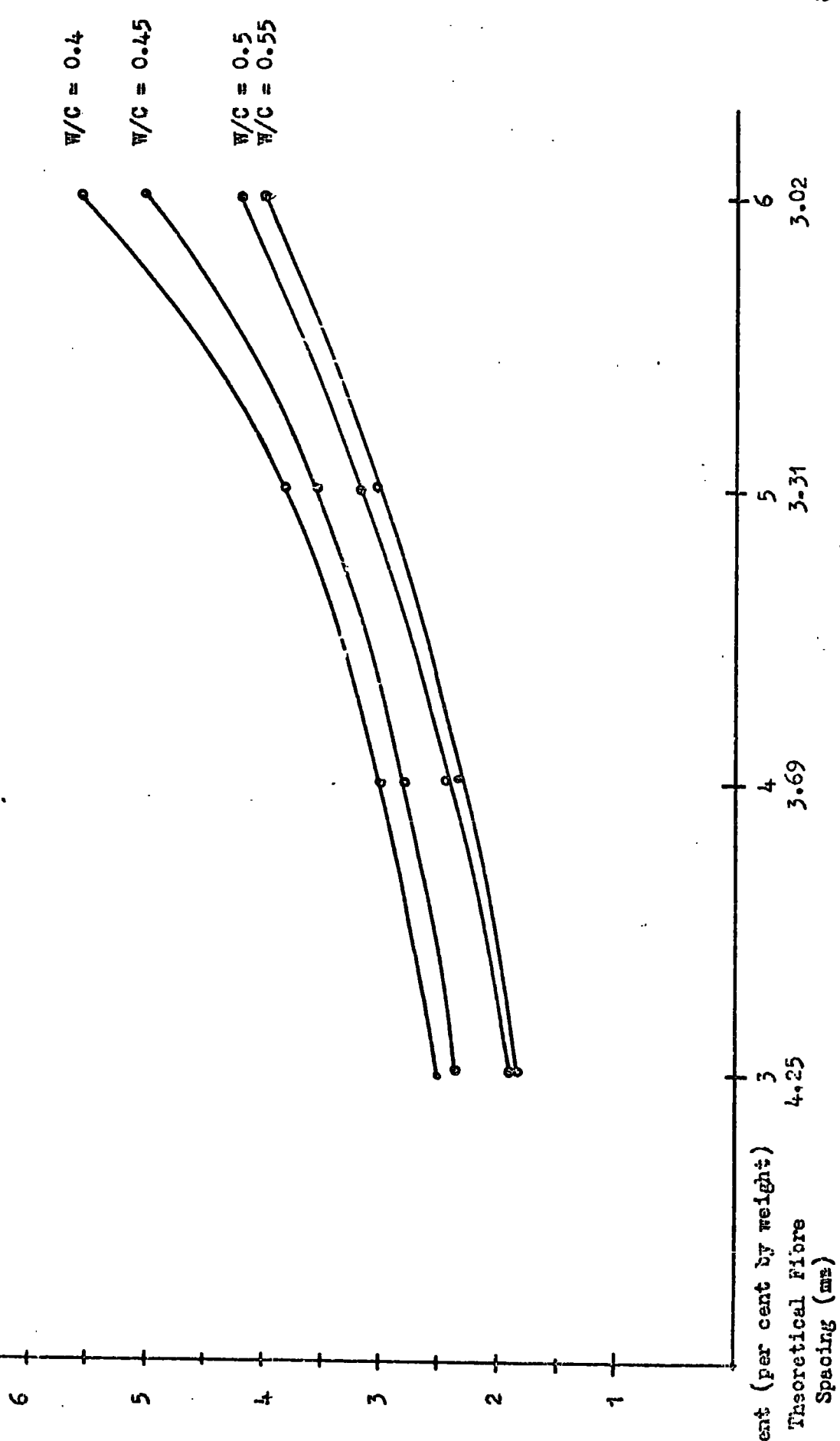

Figure 3.13 - Variation of Modulus of Elasticity with Fibre Content.

First Crack
Strength
($\bar{\sigma}$, mm^2)

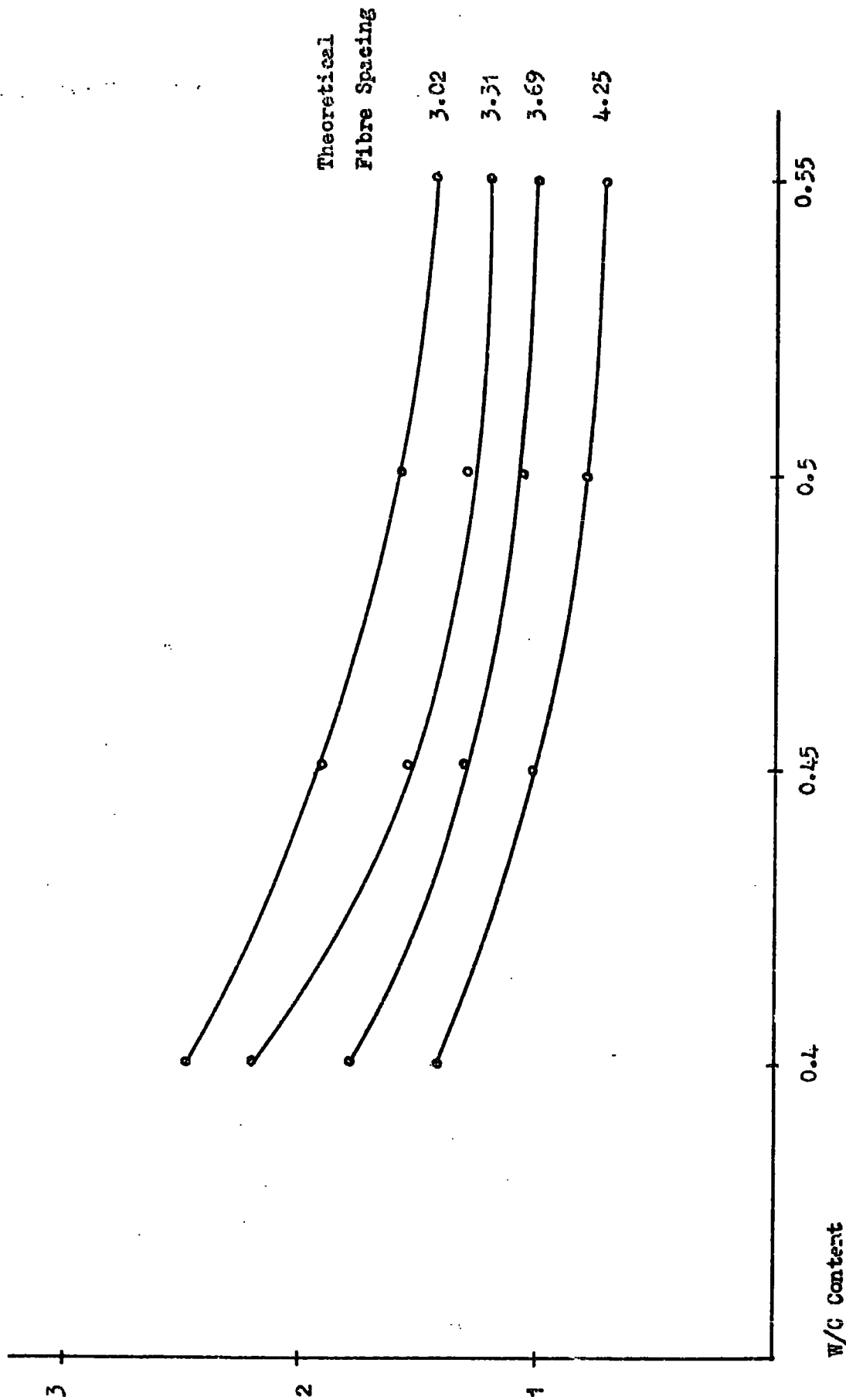

Figure 3.14 -- Variation of First Crack Stress to W/C ratio for different theoretical fibre spacing.

Figure 3.15

Per cent Relative Increases in Strength
with Varying Fibre-cement Ratios for
Different W/C Contents.

<u>W/C</u>	<u>f/c</u> per cent by weight	<u>Strength</u> per cent increase relative to 3 per cent
0.4	3	0
0.4	4	23
0.4	5	54
0.4	6	69
0.45	3	0
0.45	4	39
0.45	5	52
0.45	6	69
0.50	3	0
0.50	4	25
0.50	5	40
0.50	6	76
0.55	3	0
0.55	4	47
0.55	5	64
0.55	6	96

Figure 3.16Average IncreasesIn Strength

<u>Theoretical fibre spacing mm.</u>	<u>Average per cent increase</u>
4.25	0
3.69	34
3.31	55
3.02	78

Base figure fibre spacing of 4.25

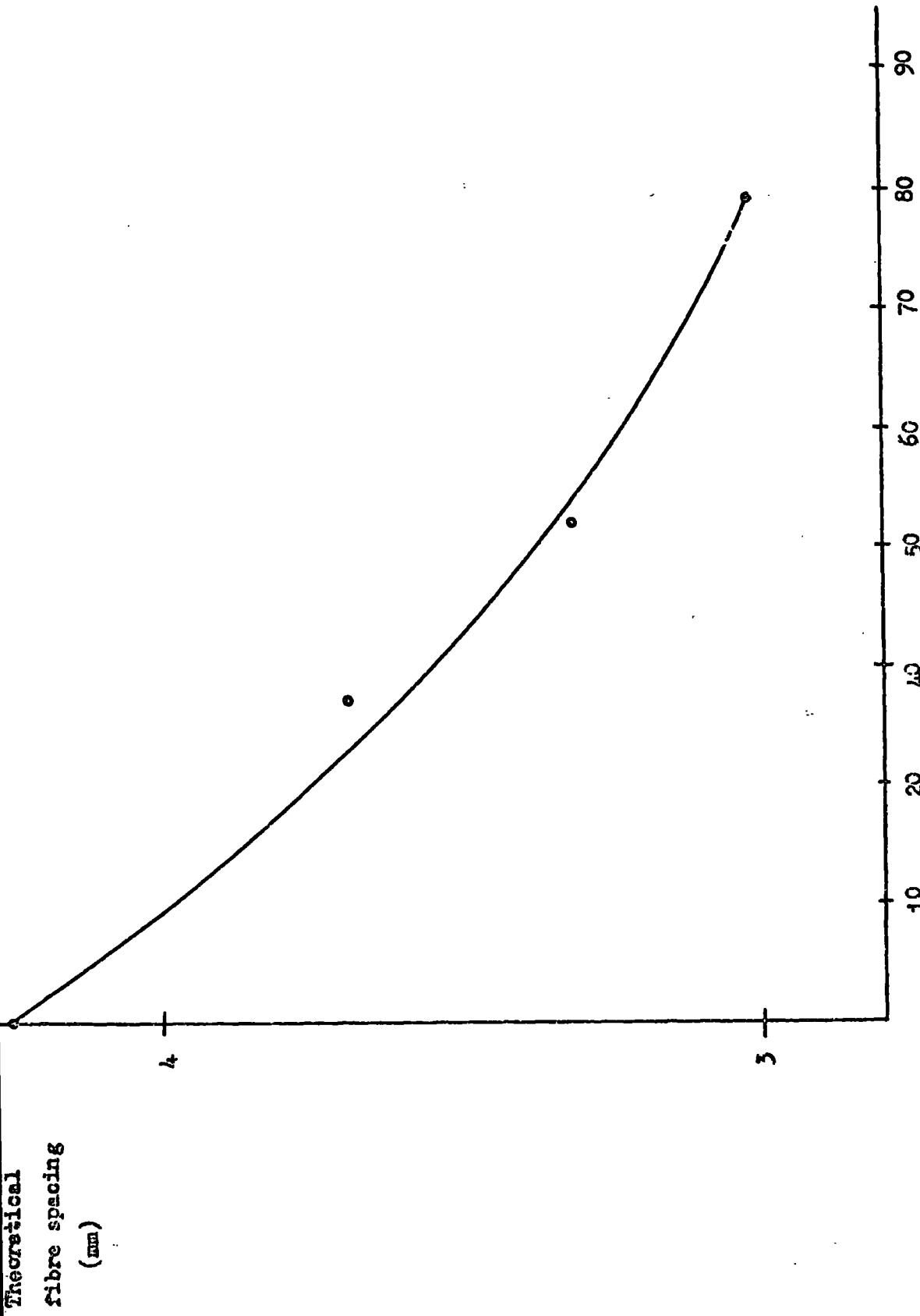

Figure 3.17 - Variation in Strength with Theoretical Fibre Spacing (per cent)

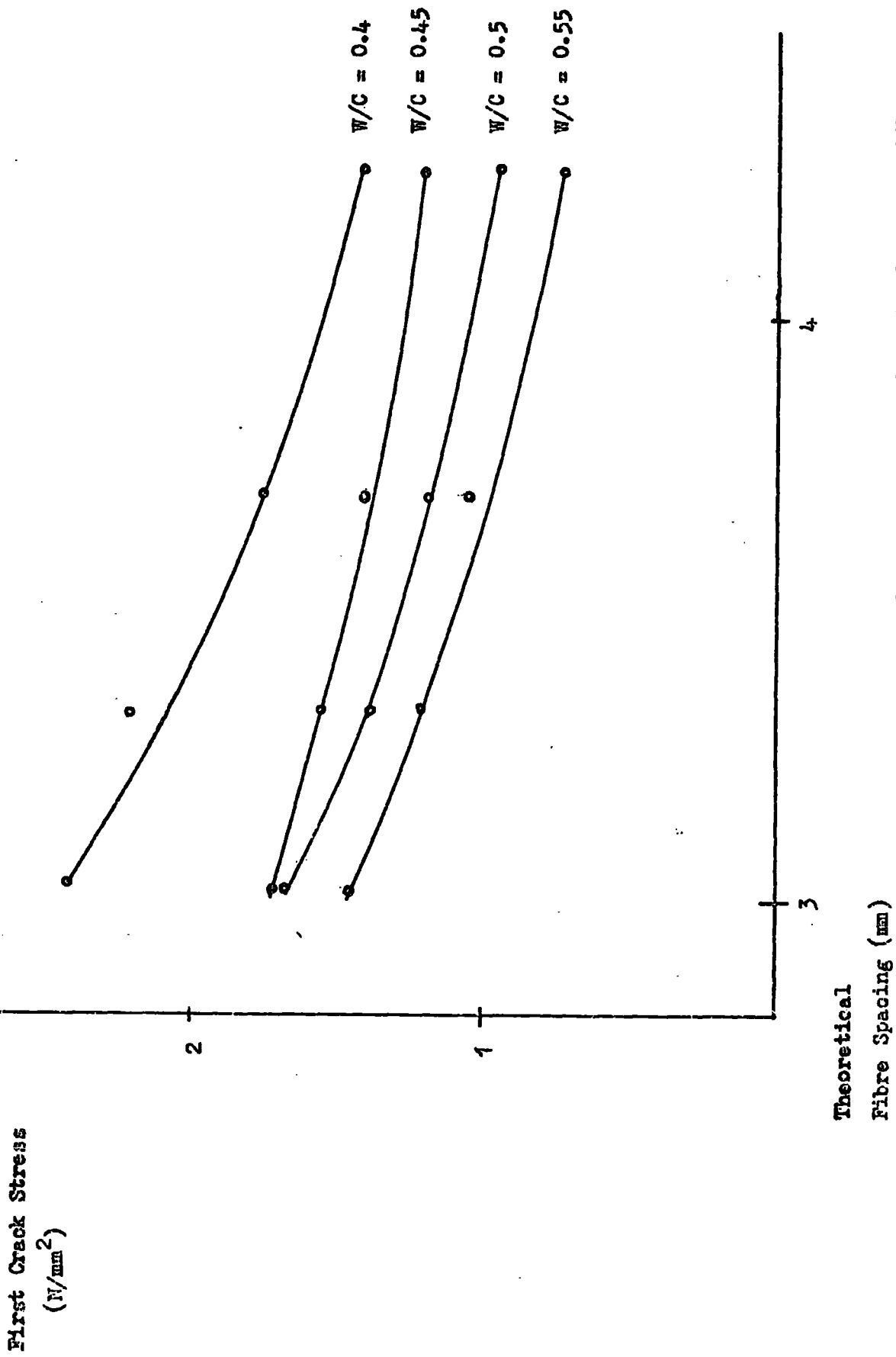

Figure 3.18 - Variation of First Crack Stress with respect to Theoretical Fibre Spacing.

Theoretical
Fibre Spacing (mm)

First Crack Stress
(N/mm²)

CHAPTER 4
SANDWICH SECTIONS

4.1 Introduction

A structural sandwich beam can be described as a composite construction of alternate layers of dissimilar elements, where two outer layers called faces are of high density material with high stiffness and membrane strength, and the central layer between two faces, the core, is of low density, strength and stiffness.

The function of the core from a structural point of view is twofold. Firstly, the core must keep the faces apart and stabilise them. It must possess a certain rigidity against deformation perpendicular to the plane of the faces. Secondly, the core must enable the faces to act as the outer layers of a beam, and to this end it must possess a certain shearing strength so as to transmit stresses from one face to the other.

The advantages of cement based sandwich beams and/or panels are considerable and can be listed as follows :

1. Good strength to weight ratio,
2. Improved thermal insulation,
3. Good surface finish due to aggregates being omitted from outer faces,
4. Less dead-weight results economic sections for columns and foundations,
5. Also the advantage of the fire resistance of the cement-based products.

Numerous combinations of different materials can give the above listed advantages, but the ideal sandwich materials are those with low density, relatively high compressive strength, high shear strength, good bonding characteristics, and low cost.

The lightweight composite of expanded polystyrene beads with cement is sandwiched between two layers of fibre reinforced cement faces to obtain a reasonably strong structural cross-section. The low average strength and density of the sandwiched section, the core, and relatively high strength of the outside layers, the faces, makes possible the construction of sandwich sections. In analysis of the beams, ordinary bending theory and simple sandwich theory assumptions are used.

The tests in this part of the research are carried out to compare the structural property values of the face and core materials that have been tested previously and to see qualitatively and quantitatively the behaviour of these two materials sandwiched together. The other reason is to pour these materials on a bigger scale to study the problems encountered during production.

4.2 Theoretical Considerations

The assumptions made to simplify the analysis of the sandwich beams can be listed as follows :

1. The whole cross-section, the core and the faces, are assumed to be elastic and isotropic,
2. The core is homogeneous,

3. The normal stiffness of the core parallel to the faces will be neglected; in other words, the core is assumed to carry no longitudinal normal stresses, σ_c ,
4. The in-plane normal stresses in faces vary linearly across the face thickness; as in the Maxwellian classical beam theory. This requires the in-plane shear stresses to vary linearly also, starting from zero at the outer face.

The essential difference between a sandwich beam and a beam obeying the assumptions of the engineering theory of bending is that the shear strains in the core of a sandwich beam may not be neglected, since the core has a low transverse modulus of rigidity, G_c . From the assumption $\sigma_c \cong 0$, it follows that the shear stress T_c in the core is independent of the depth of the cross-section.

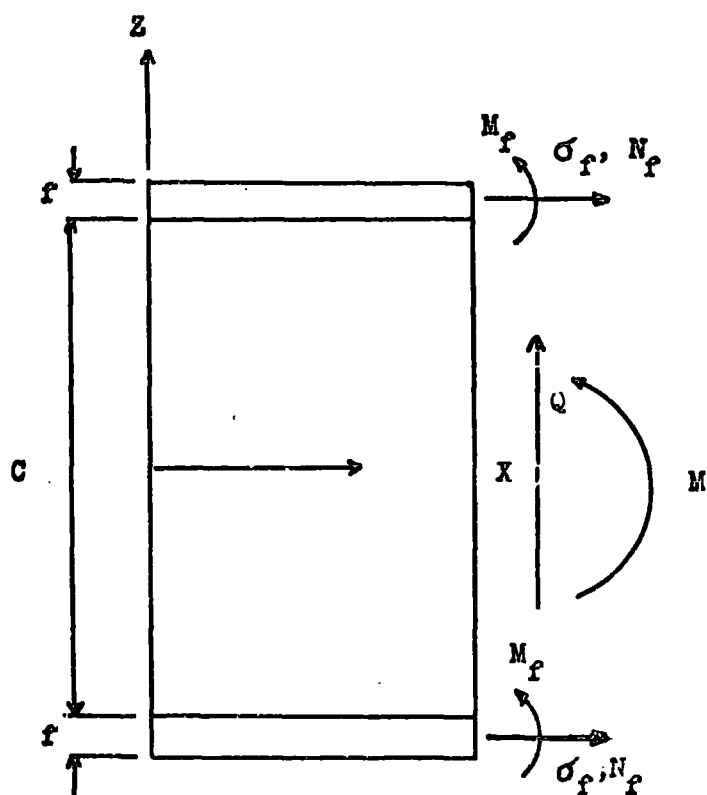

Figure 4.1 Sign Convention

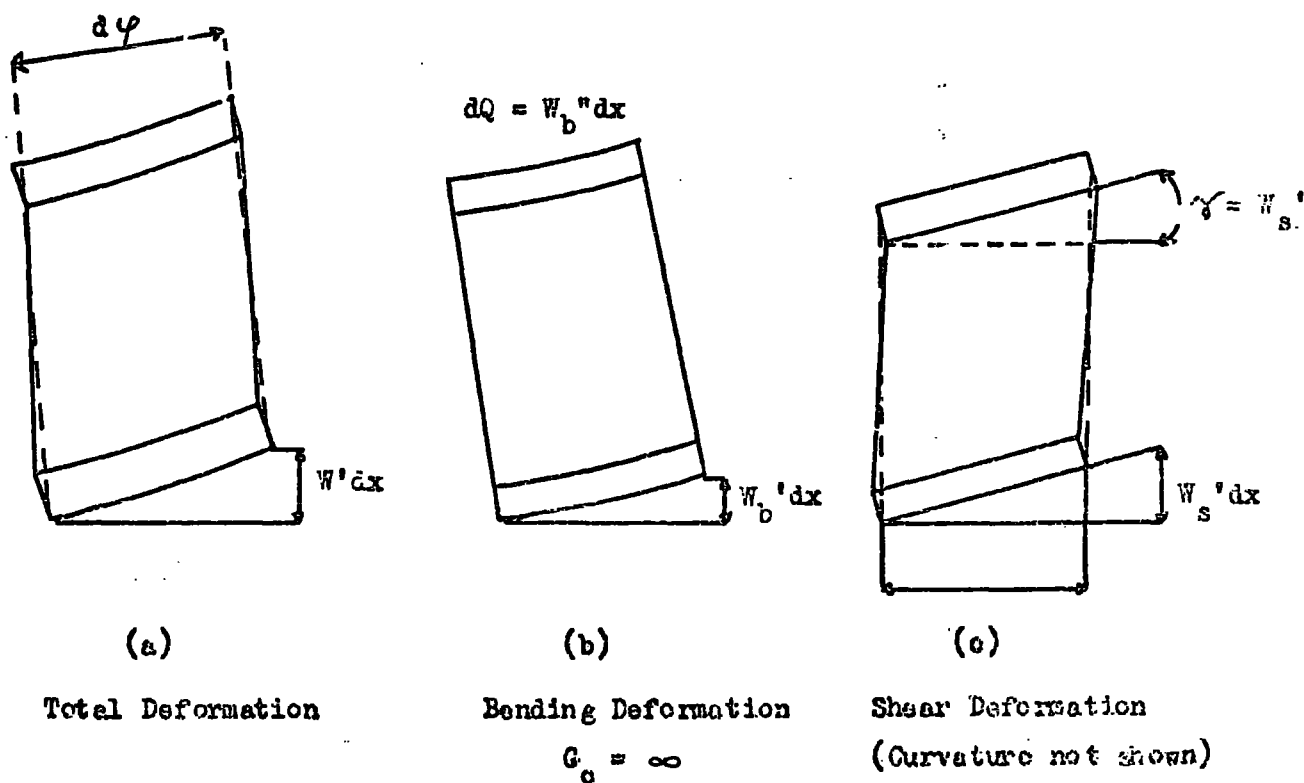

Figure 4.2 Deformation of a Sandwich Element.

The partial deflections W_b and W_s due to bending and shear respectively, form the total deflection W and can be expressed in mathematical terms as :

$$W = W_b + W_s \quad (1)$$

where partial bending deflection can be calculated from the usual engineering theory of bending.

The theoretical centre deflection of the beam under three-point bending from equation (1) can be written as :

$$W = \frac{PL^3}{48Bd} + \frac{PL}{4Sd} \quad (1a)$$

Shear stiffness can be expressed -

$$S = \frac{(c + f)^2}{c} G_c$$

where L is the span, P is the load, and d is the width of the beam.

The additional stresses corresponding to the partial deflection W_s can be found. The average shear strain γ of the sandwich element is related to the core shear strain γ_c by -

$$(c + f) \gamma = c \gamma_c$$

$$\text{thus } T_c = G_c \gamma_c = \frac{c + f}{c} G_c \gamma = \frac{c + f}{c} G_c W_s' \quad (2)$$

a dash denoting differentiation with respect to x .

In general, the shear force will be a function of x and therefore there will be a curvature W_s'' . This local curvature does not contribute to the curvature φ' of the sandwich element as a

whole; it causes bending moments, but no resultant normal forces in the faces. The stresses corresponding to the curvature W_s'' can be computed from the engineering theory applied to the separate faces.

Taking X-axis between the faces, the normal stress in the fibre Z of the faces then is -

$$\begin{aligned}\sigma_Z &= -E_f Z W_b'' - E_f Z_f W_s'' \\ Z_f &= Z - \frac{1}{2}(c + f) \text{ for upper faces} \\ Z_f &= Z + \frac{1}{2}(c + f) \text{ for lower faces}\end{aligned}$$

Integrating over the thickness f of the faces for unit width of beam we obtain the normal force in faces -

$$N_f = \pm \frac{1}{2} E_f f (c + f) W_s'' \quad (3)$$

In each face the bending moment is -

$$M_f = 1/12 E_f f^3 (W_b'' + W_s'') = B_f W'' \quad (4)$$

B_f being the bending stiffness of a face. The sign convention is given in Figure 4.1.

After substituting equations (3) and (4) total bending moment

$$M = B W_b'' + 2B_f W'' \quad (5a)$$

Equation (1) and (2) gives

$$M = B(W'' - \gamma') + 2B_f W'' \quad (5b)$$

where $B = \frac{1}{2} E_f f (c + f)^2$ $B_f = 1/12 E_f f^3$ (5c)

The bending stiffness of the beam computed according to the engineering theory is, $B_o = B + 2B_f$

$$\text{therefore } M = B_o W_b'' + 2B_f W_s'' \quad (5d)$$

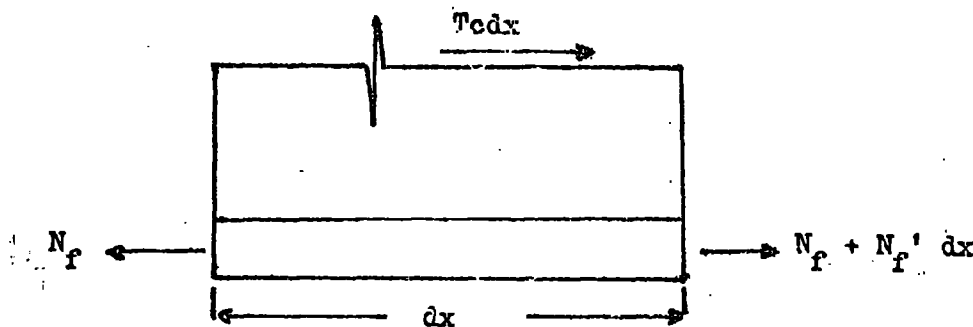

Figure 4.3 Element of lower face.

This formula can be written from the physical discussion of Figure 4.2. However from Figure 4.3 showing an element of the lower face, it follows that

$$T_o = -N_f' = -\frac{1}{2} E_f f (c + f) W_b'' \quad (6)$$

Combining equations (6) and (2) we can have a simple relationship of partial deflections -

$$W_s' = -\frac{1}{2} \frac{E_f f c}{G_o} W_b''' \quad (7)$$

We can express the strain energy stored in an element dx of beam as follows :

$$du = 2\frac{1}{2} N_f \frac{1}{2} (c + f) W_b'' + 2\frac{1}{2} M_f W'' + \frac{1}{2} \frac{T_c^2 c}{G_o}$$

Where $\frac{1}{2}(c + f) W_b''$ is the axial strain of the faces and W'' is the total curvature of the faces. Substitution of equations (2), (3) and (4) yields -

$$du = \frac{1}{2} B W_b''^2 + B_f W''^2 + \frac{1}{2} S W_s'^2 \quad (8)$$

Applying the engineering theory of bending to the beam under consideration it is also found that -

$$T_c = \frac{1}{2} E_f f (c + f) \frac{Q}{B_c} \approx \frac{Q}{c + f}$$

So can be computed by equating the shear strain energy of an element dx , $T_c^2 c dx / 2G_c$ to the work done by the shear force, which is $\frac{1}{2} Q \gamma dx = Q^2 dx / 2S_c$ by definition. (Reference No.17)

This leads to :

$$\frac{T_c^2 c dx}{2G_c} = \frac{Q^2 dx}{2S_c} = \frac{1}{2} Q \gamma dx \quad (9a)$$

$$\frac{T_c^2 c}{G_c} = \frac{Q^2}{S_c} \quad \text{since } T_c \approx \frac{Q}{c + f} \quad (9b)$$

$$S_c \approx \frac{(c + f)^2 G_c}{c} \quad (9c)$$

$$S_c \approx S \quad (9d)$$

By introduction of S into Equation (7) this equation takes the form -

$$W_s' = - \frac{B}{S} W_b''''$$

Also from a physical discussion B_0 can be equated B for sandwich sections with thin faces assuming :

$$c + f \geq 10f \quad (11a)$$

$$B_f = \frac{1}{12} E_f f^3 \quad (11b)$$

$$B = \frac{1}{2} E_f f (c + f)^2 \quad (11c)$$

$$B \geq \frac{1}{2} E_f f (100f^2) \quad (11d)$$

$$B \geq \frac{1}{2} E_f 100f^3 \quad (11e)$$

$$\therefore 600B_f \leq B$$

$$\therefore B_0 \cong B \quad (11f)$$

But it should be kept in mind that in regions of high rate of change of shear the contribution of shear load to the bending moment in the faces is considerable, and the second term of equation (5d) cannot be neglected.

For regions of low shear value, equation (5d) can be modified as -

$$M \cong E I_b'' \quad (12)$$

4.3 Experiments and Procedure

Sandwich beams tested were 120 x 120mm. in cross-section and 1500mm. long. The face thicknesses were 10mm. each. Two of glass fibre reinforced and two of steel fibre reinforced cement samples were tested. The bond failure of reinforcement with the matrix under small bending tensile stresses due to third point loading

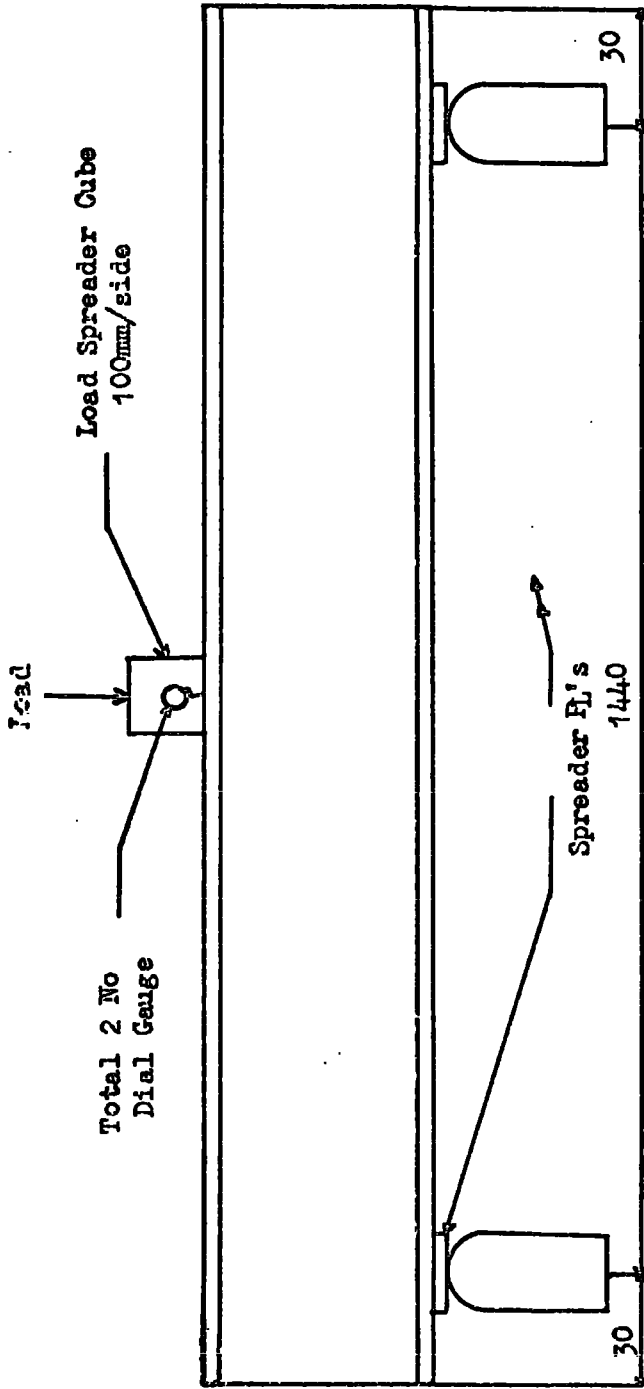

Figure 4.4 Testing under third-point load.

forced the author of this research to look for a more effective reinforcement for the faces. Wire mesh was found to be the most suitable reinforcement considering the following points :

1. The length of the wire mesh; being continuous all along the length of the face therefore providing enough bond length to ensure a flexural failure of the beam rather than a reinforcement to cement bond failure,
2. The thickness of the mesh; thin enough to be embedded effectively into the 10mm. thick faces, but thick enough to reinforce the section,
3. Grid of the mesh; to find a large enough grid of the mesh for an easy penetration of the cement paste during pouring the faces after placing the reinforcement, but also small enough grid to achieve the 'critical fibre spacing' (see section 3) for the crack arrest mechanism to work.

The suitable reinforcement of 1250 x 2500mm. sheet was supplied by 'Expamet Limited' of Hartlepool, with diamond mesh, order serial No. 1299. It was rolled from expanded steel. The maximum opening of the mesh was 10mm. and thickness 2mm. Two mesh reinforced beams were poured and failure stresses twice the fibre reinforced samples was reached. In both cases the failure of the beams was due to snapping of the reinforcement.

The mesh provided an effective crack arrest reinforcement from

qualitative observations. The tested samples did not show any visible cracks even after the reinforcement had snapped. A further increase in load opened a crack at the snap position, and a bond failure occurred due to longitudinal shear between the top face and the core material. The second beam reinforcement was cut 10mm. wider on the sides 140 x 1520mm. and the spare lengths bent 90° to the horizontal plane of the faces such that the bent lengths were embedded into the core of the beam. A better bond is achieved between sandwiched sections.

In the case of the fibre reinforced beams, there was no apparent bond failure between the core and the faces. Some of the fibres were placed between faces and the core material during construction of the samples. This might be the cause of the better bond of the sections.

All of the sample faces were poured in the same manner. (See Section 3, For the faces). A different approach has been tried to speed up the construction of the core. First the maximum amount of beads that can be fitted into the core space is determined. Then these beads are transferred to an electrically operated concrete mixer and mixed with cement paste of water cement ratio of 0.35 - 0.37. A homogeneous mix of density of 0.80 - 0.83 can be achieved with water-cement ratios of 0.4. Since water only helps the cement to change into paste and the method of pouring the core is not significantly affected by the physical flow characteristic of the paste; a more rigid and stronger section of low-water

content can be obtained. It is vital to observe and control closely the amount of cement to be added, because it determines the homogeneous distribution of the beads. With experience it is simple to achieve the desired state of the mix.

Once this mix is transferred into the molds, tamping is required to fit the mixture into the core space in the formwork. The left over is usually less than one per cent by weight of the total mix. Since filling of the voids between the beads is observable by sight, it can be assumed that a reasonably homogeneous distribution of the beads and filling of the voids is achieved.

To construct the top face of the sample it is necessary to wait for the core material to set so that (i) the beads do not move up into the face during vibration, and (ii) to achieve a uniform thickness of the face, because in wet state the core is soft and compressible like an air cushion. The weak bond of the top face to the core can be related to the above mentioned time-delay of pour of the sections.

All the samples had a constant water-cement ratio of 0.4. The steel fibre reinforced samples had a fibre to cement ratio of six per cent by weight. The glass fibre reinforced fibres had a fibre cement ratio of 0.33 per cent by weight. Rapid hardening cement was used for all the samples. The beams were transferred to the temperature controlled curing tank after setting for about 24 - 30 hours.

The testing was done on a 150 Bradford Power Cylinder, Serial No. 23379, under third point load. The midspan deflections were measured by means of two 0.01mm. partition dial gauges placed symmetrically on two sides of the loading cell, (see Figure 4.4). Spreader plates were placed by means of plaster of paris under the support points of the samples to stop the supports penetrating into the core. A spreader concrete cube, side of 150mm. is placed under the load. All the samples were tested to failure.

Figure 4.5 Modulus of Elasticity
of Face Material.

	W/C	f/o By weight	Cement: sand by weight	E N/mm ²
Steel Fibre	0.4	4%	-	5603
Glass Fibre	0.4	0.33%	-	4342
Wire Mesh	0.4	-	1 : 2*	8983 ⁺

* To be used for slab analysis.

+ Assumed 'E' value constant for sand-cement mixes and pure cement mixes.

FIGURE 4.6 Steel Fibre Reinforcement

$w/c = 0.4$, $f/c = 4$ per cent by weight

Load KN	δ Midspan Right mm.		δ Midspan Left mm.		δ Average experiment- al mm.	δ Theor- etical mm.	% Error
	Sample 1	Sample 2	Sample 1	Sample 2			
0.11	0.38	0.10	0.14	0.00	0.076	0.09	+ 8
0.22	0.45	0.20	0.22	0.00	0.22	0.18	+ 22
0.33	0.52	0.30	0.28	0.05	0.29	0.26	+ 11
0.44	0.59	0.38	0.34	0.14	0.36	0.35	+ 2.9
0.55	0.65	0.50	0.40	0.20	0.44	0.43	+ 2.4
0.66	0.72	0.60	0.46	0.28	0.52	0.525	- 1.0
0.77	0.79	0.70	0.53	0.38	0.60	0.61	- 1.6
0.88	0.87	0.78	0.59	0.42	0.67	0.70	- 4.21
0.99	0.94	0.90	0.68	0.54	0.77	0.79	- 2.5
1.10	1.03	1.00	0.76	0.60	0.85	0.88	- 3.4
1.21	1.15	1.12	0.90	0.69	0.97	0.96	+ 1.0
1.275	-	1.16	-	0.72	0.94	1.01	- 7.3

NOTES : 1. Self weight neglected 0.27 KN = 0.18 KN/M

2. Beam assumed elastic until failure for theoretical deflection.

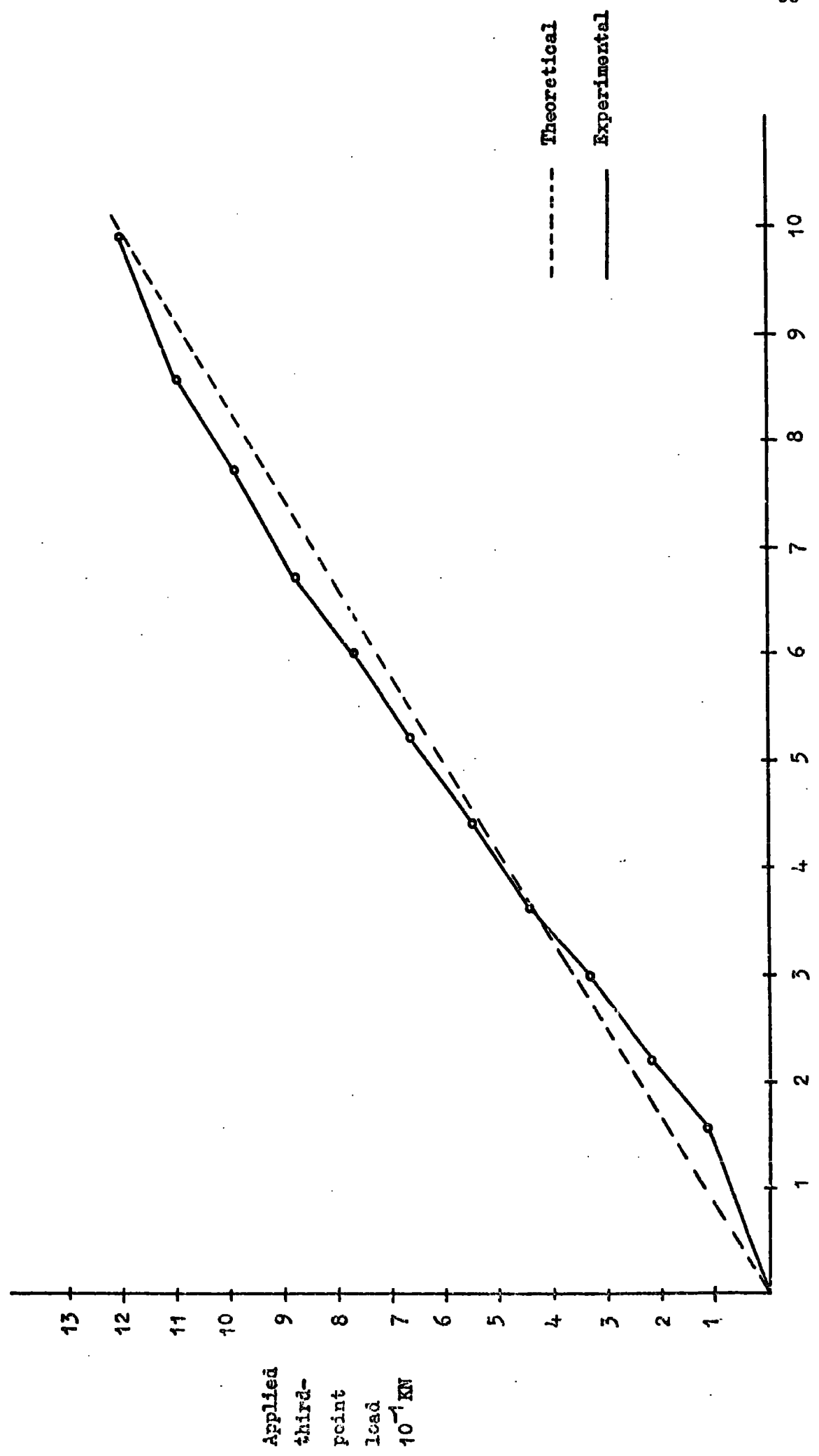

Figure 4.7 Faces Steel Fibre Reinforced Fibres
 $f/c = 1\%$ by weight $W/C = 0.4$

Midspan Deflection
 10^{-3} mm.

Applied third-point load
 10^{-1} kN

FIGURE 4.8 Glass Fibre Reinforcement

w/o = 0.4 f/o = per cent by weight

Load KN	δ Midspan Right mm.	δ Midspan Left mm.	δ Average experimental mm.	δ Theor- etical mm.	% Error
0.11	0.85	0.80	0.83	0.10	730
0.22	0.86	0.84	0.85	0.21	305
0.33	1.10	0.88	0.99	0.31	219
0.44	1.28	0.88	1.08	0.42	157
0.55	1.38	0.90	1.14	0.53	115
0.66	1.45	0.92	1.19	0.63	89
0.77	1.53	0.96	1.25	0.73	71
0.88	1.60	1.00	1.30	0.84	55

- NOTES :**
1. Self weight neglected 0.27 KN = 0.18 KN/M.
 2. Beam assumed elastic until failure for theoretical deflection.
 3. One sample unrepresentative, possibility of a potential crack in the lower face.

FIGURE 4.9 Glass Fibre Reinforcement
Adjusted Deflections and Percentage of
Error.

Load KN	δ Experimental* Average (mm)	δ Theoretical (mm)	% Error
0.11	0.1	0.1	0
0.22	0.12	0.21	38
0.33	0.26	0.31	16
0.44	0.35	0.42	17
0.55	0.41	0.53	23
0.66	0.46	0.63	27
0.77	0.52	0.73	26
0.88	0.57	0.84	32

* 0.73mm. subtracted from the values below
 (See Section 4.4)

————— Experimental
 - - - - - Theoretical
 - - - - - Adjusted

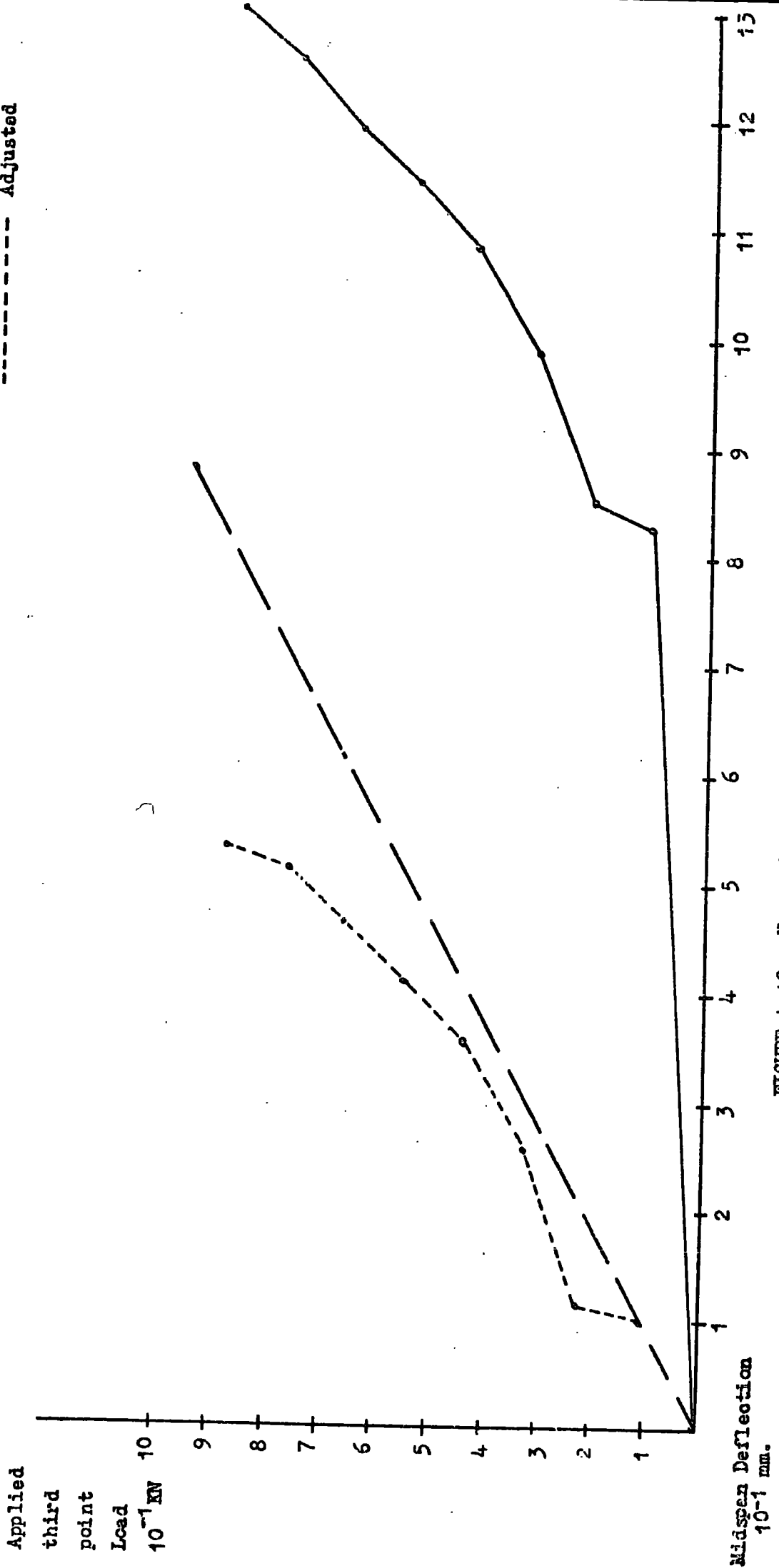

FIGURE 4.10 Faces Glass Fibre Reinforced

$f/c = 0.33\%$ by weight
 $w/g = 0.4$

FIGURE 4.11 Wire Mesh Reinforcement

W/C = 0.4

Load KN	δ Midspan Right mm.		δ Midspan Left mm.		δ Average experimental mm.	δ Theor- etical mm.	% Error
	Sample 1	Sample 2	Sample 1	Sample 2			
0.11	0.30	0.52	0.15	0.02	0.20	0.06	- 200
0.22	0.40	0.40	0.20	0.02	0.26	0.11	- 136
0.33	0.45	0.45	0.22	0.02	0.29	0.17	- 71
0.44		0.52		0.12	0.32	0.23	- 39
0.55	0.52	0.58	0.25	0.16	0.38	0.28	- 36
0.66		0.65		0.22	0.44	0.34	- 29
0.77	0.65	0.70	0.32	0.24	0.48	0.40	- 20
0.88	0.70	0.75	0.35	0.28	0.52	0.45	- 16
0.99	0.76	0.82	0.38	0.32	0.57	0.51	- 12
1.10	0.85	0.87	0.42	0.38	0.63	0.56	- 12.5
1.21	0.89	0.93	0.45	0.40	0.67	0.63	- 6.4
1.32	0.94	0.98	0.49	0.45	0.72	0.68	- 5.8
1.43	1.00	1.04	0.53	0.50	0.77	0.74	- 4.1
1.54	1.08	1.09	0.56	0.53	0.82	0.79	- 3.8
1.65	1.13	1.14	0.60	0.58	0.86	0.84	- 4.8
1.76	1.19	1.20	0.63	0.63	0.91	0.90	- 1.1
1.87	1.25	1.25	0.68	0.68	0.97	0.96	- 1.0
1.98	1.31	1.30	0.72	0.72	1.01	1.01	- 0
2.09	1.37	1.35	0.75	0.78	1.06	1.07	0.09

FIGURE 4.12 Wire Mesh ReinforcementAdjusted Deflections and
Percentage of Error.

Load KN	δ Experimental* Average mm.	δ Theoretical mm.	% Error
0.11	0.06	0.06	0
0.22	0.12	0.11	9
0.33	0.15	0.17	12
0.44	0.18	0.23	21
0.55	0.24	0.28	14
0.66	0.30	0.34	12
0.77	0.34	0.40	15
0.88	0.38	0.45	16
0.99	0.43	0.51	16
1.10	0.49	0.56	11
1.21	0.53	0.63	16
1.32	0.58	0.68	15
1.43	0.63	0.74	15
1.54	0.68	0.79	14
1.65	0.72	0.84	14
1.76	0.77	0.90	14
1.87	0.83	0.96	14
1.98	0.87	1.01	14
2.09	0.92	1.07	14

* .14mm. subtracted from the values below

(See section 4.4.)

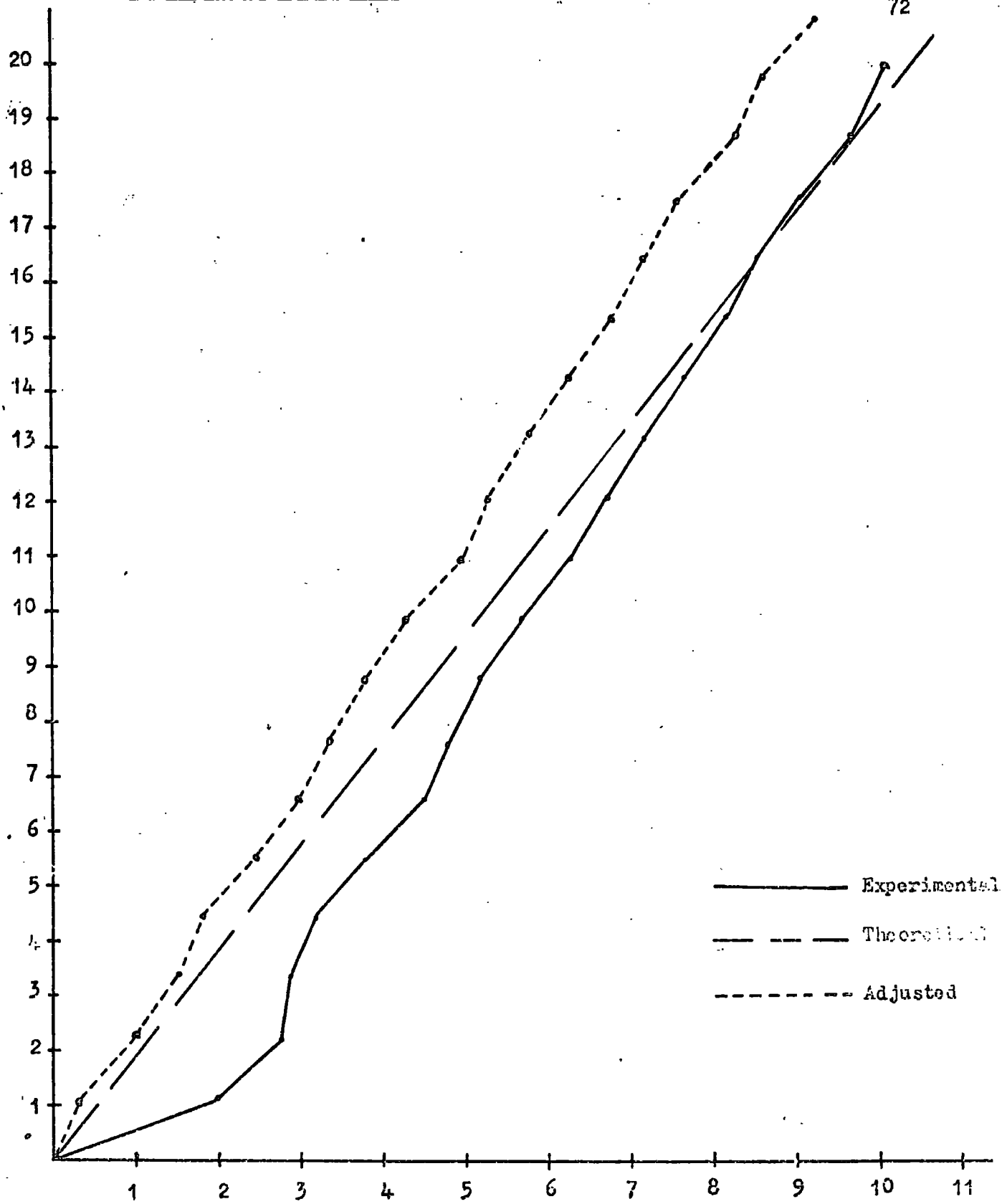

FIGURE 4.13 Faces Wire Mesh reinforced

$w/c = 0.4$

pan
 section
 mm.

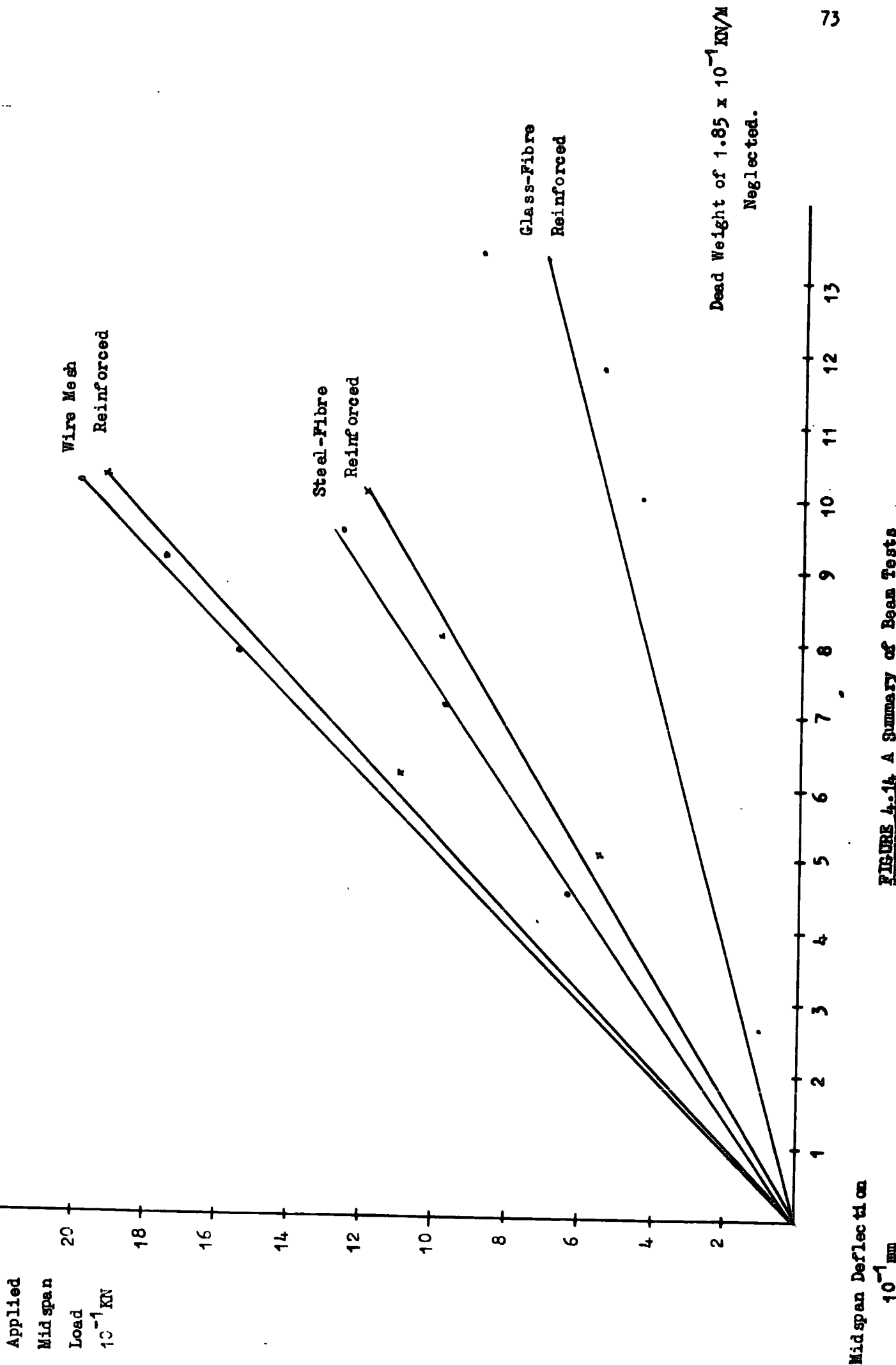

FIGURE 4.16 A Summary of Beam Tests

4.4 Discussions

The measured deflections are compared with the expected deflections in Figures 4.6 to 4.13. The high percentage error at the beginning of the experiment suggests that some experimental error has taken place. At the start of the experiments in all the samples. This might be due to the test beam actually locating itself, i.e. penetration of spreader plates.

The measured deflections at the beginning of the experiment were much higher than expected. Therefore it was felt that subtracting the difference of expected to actual deflection at the start of the experiment from all the values measured throughout the experiment and re-analysing the graphs would give a better picture of the behaviour of the beams under the load. The measured deflections at the start of the experiment were not the actual deflections due to loading of the beam and gave no idea of the structural behaviour and of the checking of the structural properties of the beam.

As can be seen from the results of the steel fibre reinforcement, Figures 4.6 and 4.7, this adjustment was not necessary for steel fibre reinforced beams because at the beginning of the experiment a high jump in the dial gauge reading was not observed.

It is believed that the most variable factor was the actual value of the modulus of elasticity and rigidity values in these experiments, which will be the main cause of the difference of the actual and theoretical deflection values. The other main

factor is the actual thickness of the faces. Even though a reasonable uniform thickness of the faces can be achieved, it is practically impossible to pour a perfect uniform thickness with the methods used in this research. The contribution of the thickness of face is very high to the bending stiffness of the section therefore to the deflections. Small variation in thickness of the face at maximum bending moment positions can affect the expected deflections to a great extent.

The maximum error of 16 per cent on adjusted results for wire mesh beams, 38 per cent for glass fibre beams, 22 per cent for steel chopped wire beams is considered to be within reasonable error limits. The unavoidable experimental errors, such as twisting of forms, equipment calibration irregularities, etc coupled with the section thickness variations, variable structural property values and considering the assumptions of deflection theory suggest that the values found in the earlier parts of this research are correct within the error limits.

4.5 Beam Finite Element Analysis

With the program already available (See section 4.6) a finite element analysis was done to further check the results of the beams.

The input and output data is included in the Appendix II. The results are tabulated and plotted in Figures 4.16 - 4.21. The input data is shown on Figure 4.15.

Since modulus of elasticity and shear modulus have been calculated by experiments for the core, the Poisson's ratio value is calculated from the relationship

$$G = \frac{E}{2(1 + \nu)} \quad (4.13)$$

For the face material it is assumed $\nu = 0.3$ and the shear modulus is calculated accordingly.

The beam was loaded on node points 1560 and 2560 with a unit load. To achieve a statically determinant condition the beam was restrained in the y-direction, both faces, at node points 2000 and 2060. (See Appendix II)

This simple beam analysis served to demonstrate the validity of the numerical model so that a similar analysis of the slab could be performed with greater confidence. The comparison of the laboratory and numerical model deflections appears to be very good.

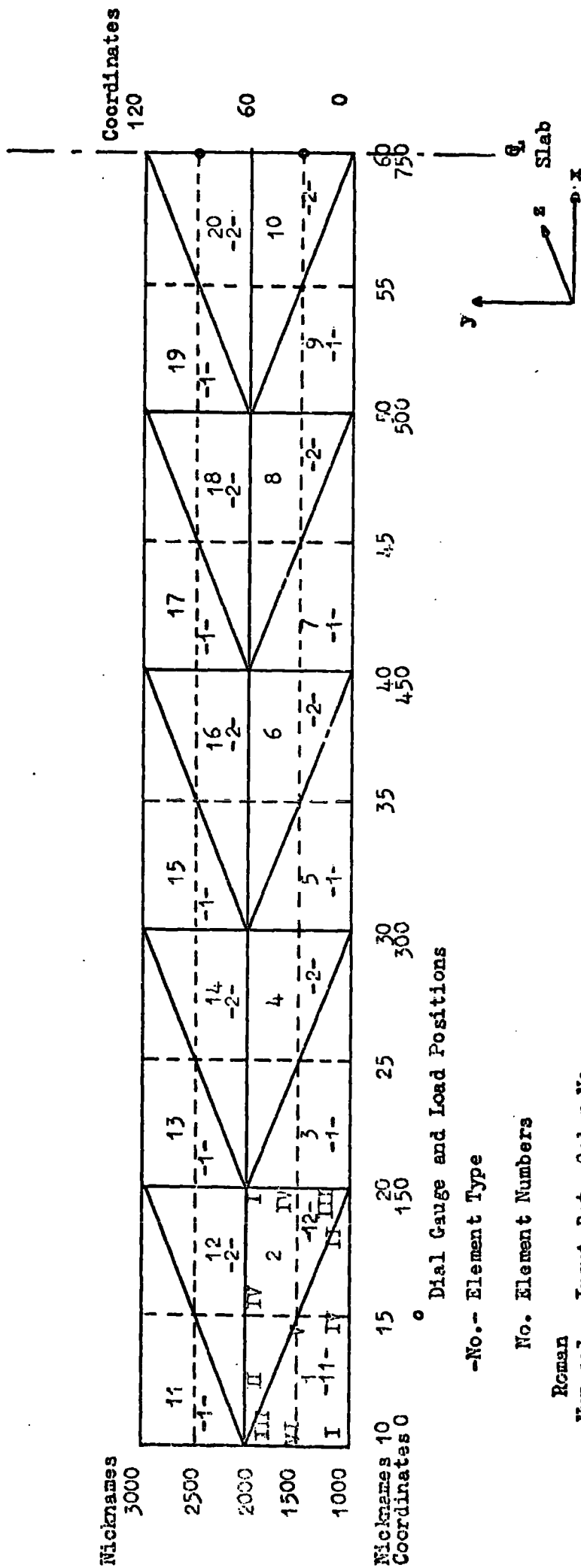
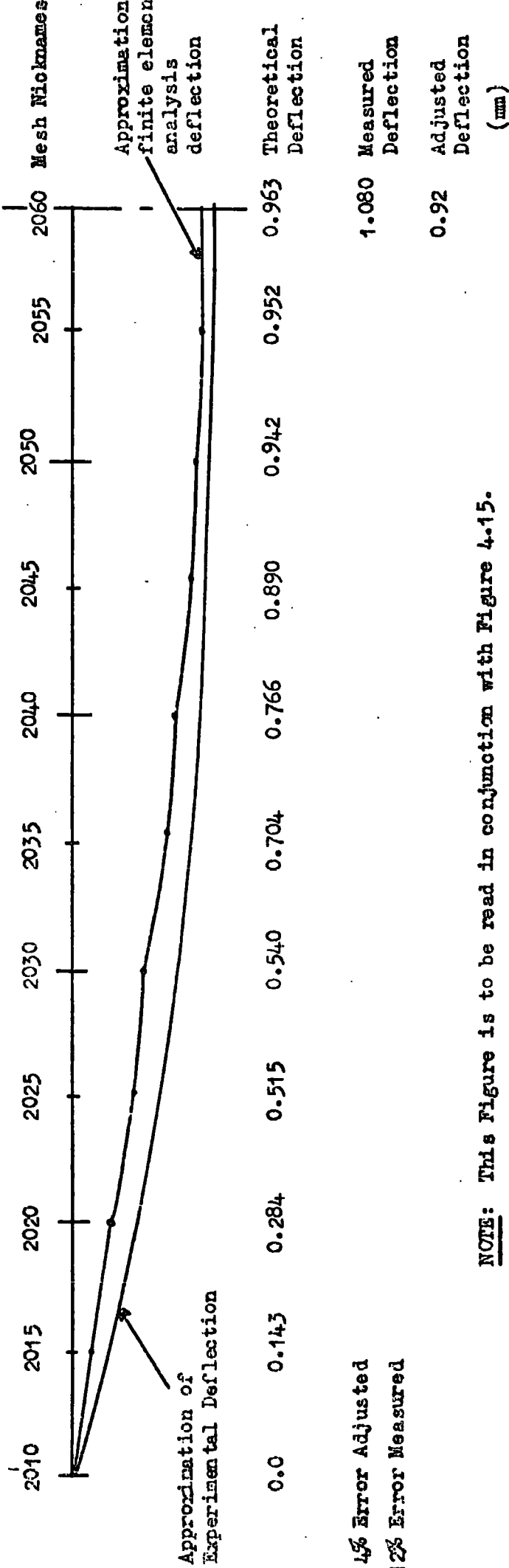

FIGURE 4.15 Element Layout For Beam

Finite Element Analysis



NOTE: This Figure is to be read in conjunction with Figure 4-15.

4% Error Adjusted
12% Error Measured

FIGURE 4.16(a) Beam Vertical Displacements
Wire Mesh Reinforced Faces
Before Failure - 2km at Midspan

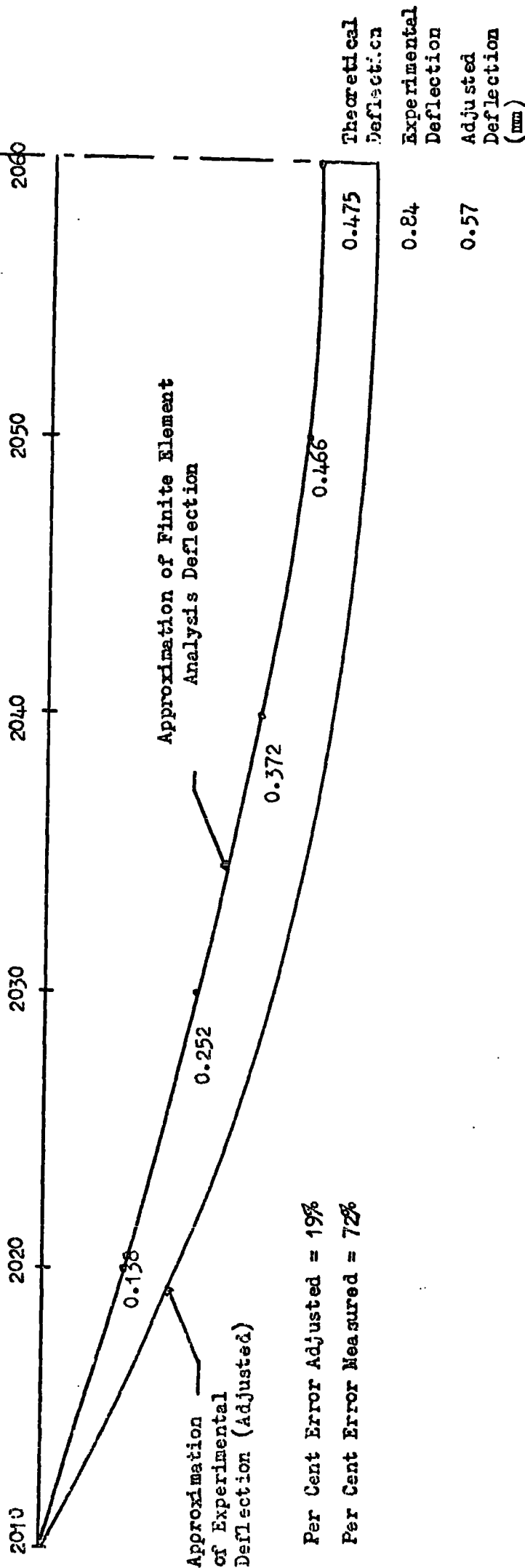

FIGURE 4.16(b) Beam Vertical Displacements
Glass Fibre Reinforced Faces
Before Failure 0.8 kn at Midspan

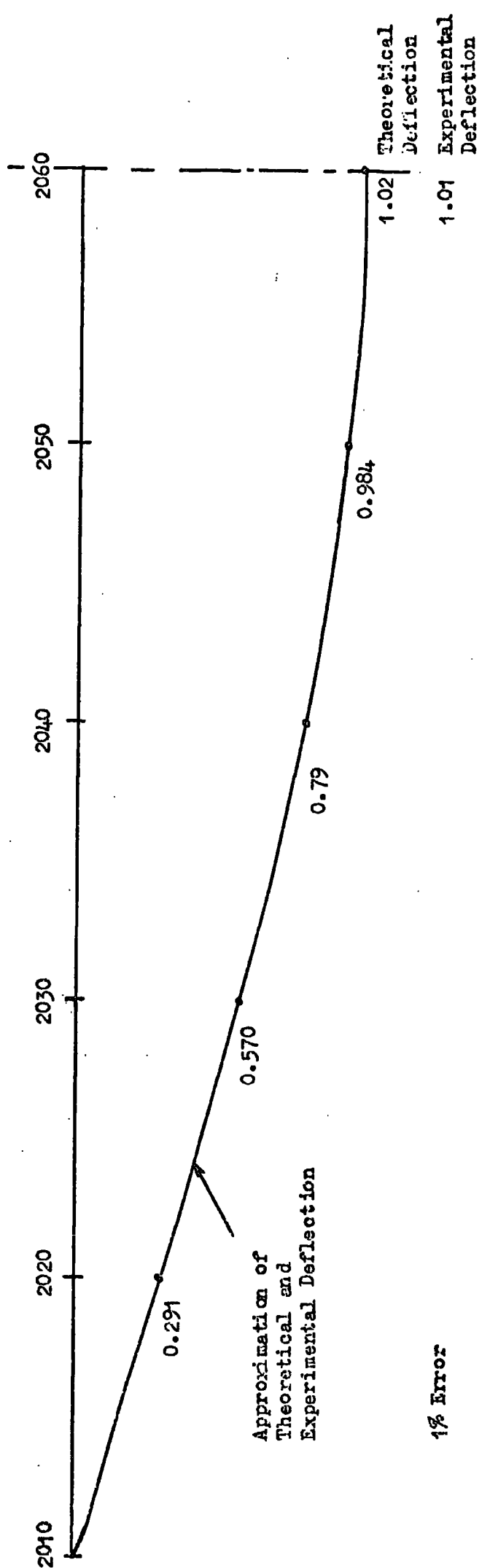

FIGURE 4.16(c) Beam Vertical Displacements

Steel Fibre Reinforced Faces

Before Failure 1.275 kn at Midspan

4.6 Sandwich Slabs

In this part of the research a sandwich slab 1200mm. square 120mm. thick with wire mesh reinforced faces 10mm. thick was poured. Using the structural property values found in the earlier parts of this research a finite element analysis was done by means of the available 'Irons-Quad' computer program. This program is developed at Swansea University for general finite element analysis and revised by Dr. G.M.Parton and his research assistants to take care of the stresses and displacements induced by considerable shear deflections, therefore making possible the analysis of the sandwich plates and beams.

The results of the computer run are compared with the actual experimental values the results are tabulated and plotted. The deductions are discussed in Section 4.10.

4.7 Laboratory Procedure

The formwork was designed to use the minimum amount of mould material for a reasonable size of slab that can be fabricated and tested in the laboratory conditions. It was felt that fabricating the mould walls and using the floor as the bottom of the mould would be practicable. (See Figure A.1.4).

First an equal angle frame was built using Dexian section No. 225, 1200mm. long on the perimeter. Then

1250mm. long planks, 100mm. high were bolted to the Dexian frame by 10mm. long bolts 4 No per corner.

The Dexian frame serves as edge stiffeners to stop the supports penetrating into the slab and also the reinforcing mesh is placed on top of the bottom leg of the angle which ensures the reinforcement lays on the midplane of the bottom face.

Finally a PVC sheet with edges attached to the walls of the mould on the outside, was provided at the bottom of the formwork to hold the mix inside the moulds.

To test the sample and to measure deflections, the slab had to be lifted to be placed on the knife edge supports. To facilitate the lifting operation, four lifting lugs were placed symmetrically inside the moulds.

After the sample was poured and cured for seven days the slab was lifted by means of a 3 cwt capacity 'Coolie' fork lift Serial No. 4100-68 and 20 cwt capacity hydraulic crane Serial No. 1264 8434.

The pouring of the sample was done in a similar manner as for the beams. A wire mesh continuous throughout the plane of the face was placed on top of the leg of the Dexian frame. The particulars of the wire-mesh are the same as for that used

for the beams. To avoid sag of the mesh due to own dead weight at centre of the mould, 4mm. thick 50 x 50mm. wire mesh pieces were placed at 300mm. intervals. This ensures the reinforcement is, i) parallel to the plane of the faces, ii) embedded in the faces thoroughly. The wire mesh was bent all along the edges, about 10mm., ninety degrees to the plane of the faces, so that the reinforcement did not move relative to the core and a better bond was achieved between the faces and the core.

All the mixes were poured in the same manner as described in section 4.3, but mixed in a concrete mixer, Type 3415, Serial No. 393540.

Tamping was vital to ensure that the paste penetrated below the mesh. A tamper 140mm. deep, 30mm. handle, 110mm. below the top of the walls, was fabricated. The bottom face was tamped in its place. The purpose of the tamper was, i) to act as a vibrator to compact the cement paste, ii) to measure the thickness of the bottom face, since the floor was perfectly levelled, the walls of the mould were ninety degrees to the floor, and the tamper did not deflect, i.e. was of infinite rigidity.

Once the required thickness and the compaction of the face was achieved, the unsatisfactory irregularities were corrected by means of a float, but the surface as a whole

was never made smooth to help the bond between the face and the core.

The core material was fitted by means of another tamper 10mm. deep below the handle to ensure the even thickness of the top face. Once the core was fitted about four hours lapsed before the placing of the top face. (See section 4.3).

The top face was poured in the same manner as the bottom face, but the top surface was made smooth as much as possible by a float.

The whole slab is covered with wet cloth and a PVC sheet for about 72 hours for curing purposes.

A constant water-cement ratio of 0.4 was maintained for all the mixes and a sand : cement ratio of 2 : 1 was used for face mixes. The sand was fine building sand.

The sieve analysis is given below.

<u>Mesh No.</u>	<u>% Passing</u>
18	94
25	76
52	37
72	21.8
100	7.8
170	1
200	0.4
Fan	0

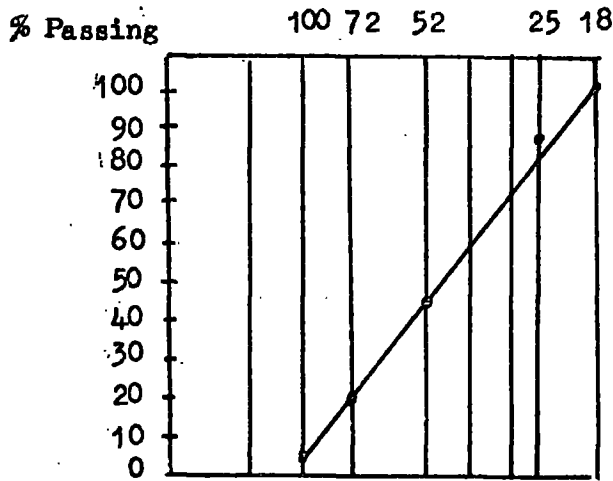

Particle Distribution

4.8 Testing the Slab

The slab was simply supported all along the edges of the slab. The knife edge supports were placed directly under the edge stiffening angles. The knife edge supports were connected to each other at the corners to stop them moving due to rotations of the slab under load.

The slab was loaded centrally with standard weights of 100 newtons each as shown in Figure 4.22. The dial gauges and 'Demec' 50mm. length mechanical strain gauge points are located as shown in Figures 4.22.

A total of 6 No. dial gauges were used. The strain gauge points were at three positions, 6 points to each position, (a total of 18) were firmly attached to the top of the upper face by means of 'Araldite.'

About 48 hours elapsed between the location of the gauge points and the testing, in order for the 'Araldite' to set.

The central load was applied at 2000 newton intervals,

and strain and displacement measurements were recorded. The values are tabulated in Figures 4.21 and 4.22.

All the measured strains are converted to the principal strains by means of the Mohr's circle, and then converted to the principal stresses with the relationships below to compare the results with the finite element analysis outputs.

$$\sigma_1 = \frac{E(\epsilon_1 + \nu\epsilon_2)}{(1 - \nu^2)} \quad (\text{Equation 4.14a})$$

$$\sigma_2 = \frac{E(\epsilon_2 + \nu\epsilon_1)}{(1 - \nu^2)} \quad (\text{Equation 4.14b})$$

After removal of dial gauges the slab was loaded at the centre with 7 kN central load. There was no sign of failure or excessive deflections. Expected failure load was 23.6 kN central concentrated load comparing the beam failure load to slab finite element stresses. The loading condition was changed and the slab was loaded with uniformly distributed load, 9 kN/m². This load was left on the slab for about 48 hours. The slab was strong enough to take this load. No excessive deflections or failure cracks were observed.

The slab was then transferred to the 'Denison' loading rig to test it to failure.

There were no local failures. The first crack was observed on the tension face about 25 kN. At 42.8 kN load the bottom face reinforcement snapped and the crack opened between the two opposite sides.

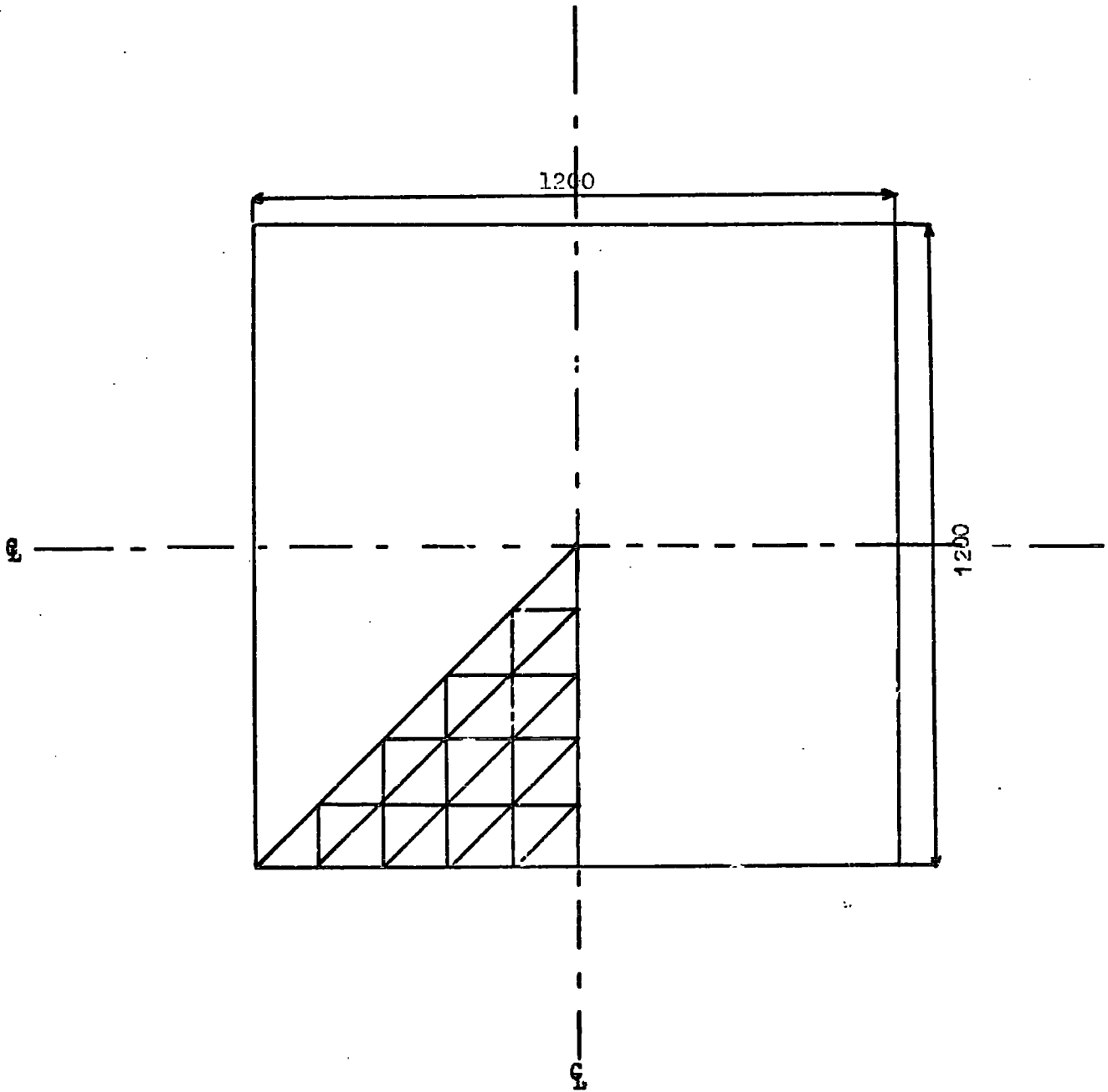

FIGURE 4.17 Section Of The
Slab Analyzed

Dial Gauge Positions

(No.) = Element Numbers

-No.- = Element Type

Roman = Input Data Order No. Numerals

Millimeter Coordinates

10 15 20 25 30 35 40 45 50 55 60 650 600 500 450 400 350 300 250 200 150 100

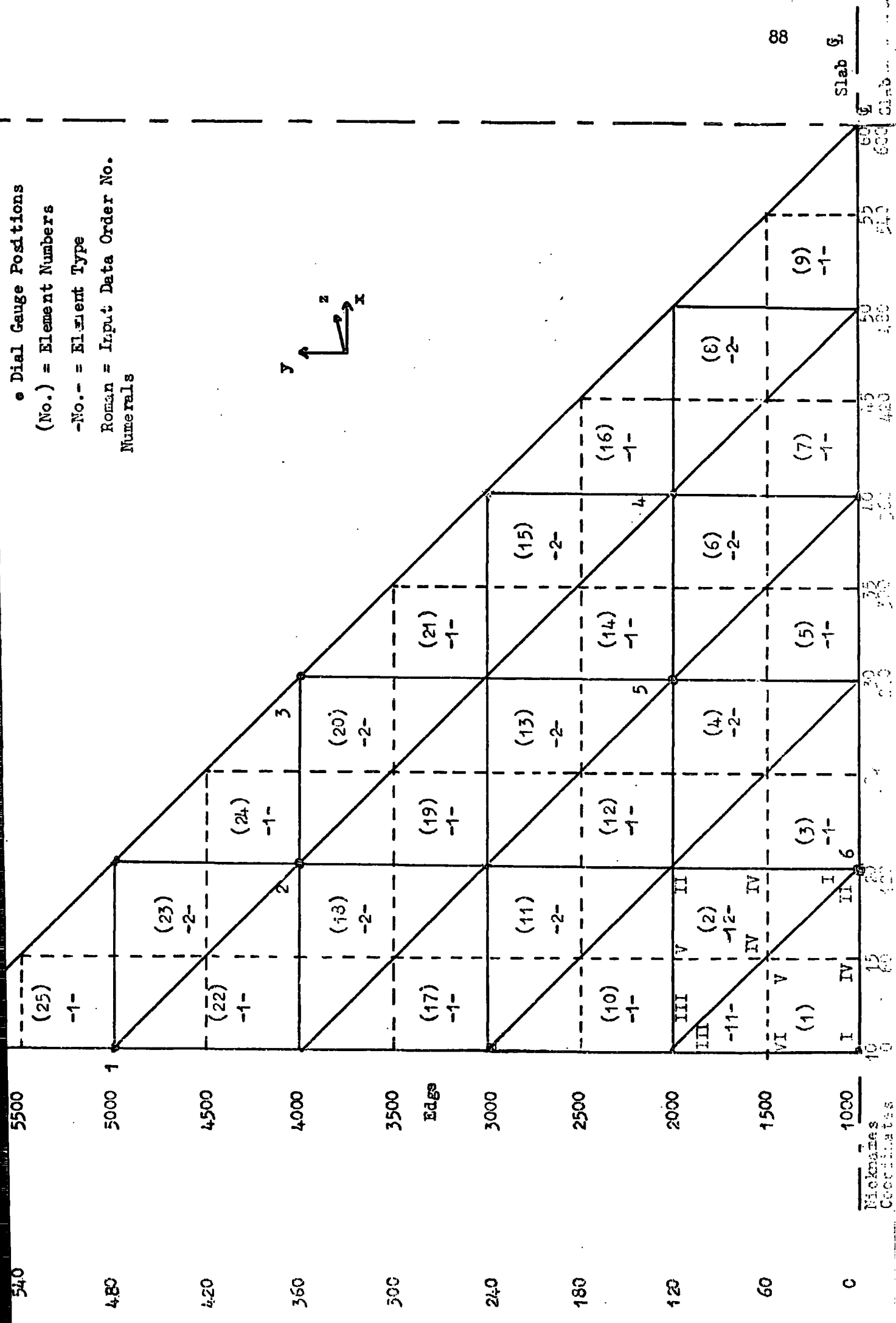
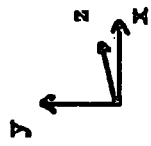

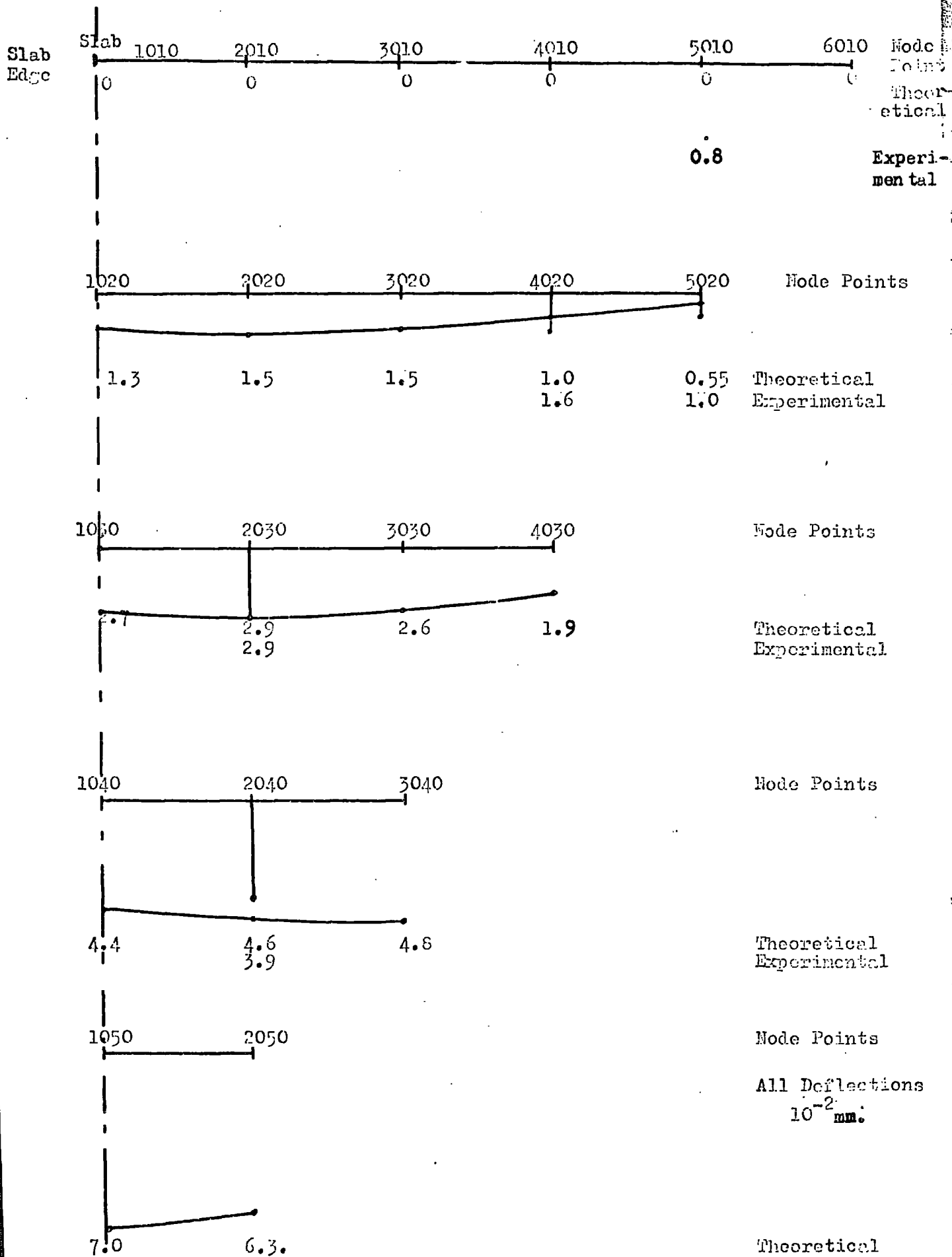

FIGURE 4.19 Slab Deflection Under 4m Central Load*

*Computer Output to be read in conjunction with Figure 4.18.

4.9 Slab Computer Finite Element Analysis

Since the slab was tested under a central point load, and supported symmetrically all around the periphery, and the dimensions of the slab are symmetrical with respect to geometrical centre lines (See Figure 4.17), it was felt that analysing only one eighth of the slab will show the structural behaviour of the whole slab.

A unit load was placed on node point 1555 and 1055 (See Figure 4.15). All the input and output data is included in the Appendix for further reference.

The Poisson's ratio and face shear rigidity values are calculated as described in section 4.5.

Dial Gauge Position	Vertical Theoretical Displacement (mm)	Vertical Experimental Displacement (mm)	Per cent. Error
1	0	0.008*	-
2	0.010	0.016	+ 60
3	0.006	0.010	+ 66
4	0.046	0.039	- 6.65
5	0.029	0.029	0
6	0.013	0.016	+ 18.7

* Due Rotation

FIGURE 4.20 Theoretical and Experimental Vertical Displacements

Dial Gauge Position	Maximum Principal Stress kn/m ²		Minimum Principal Stress kn/m ²	
	Experi- mental	Theor- etical	Experi- mental	Theor- etical
Element 5 ^{1,2}	56.3	54.08	41.35	- 8.72
Element 24 ¹	34.5	101.83	21.7	- 98.77

1. See Finite Element Analysis.
2. Average Values for Position 1 and 2 of Dial Gauges.

FIGURE 4.21 Comparison of Theoretical
and Experimental Principal
Stresses.

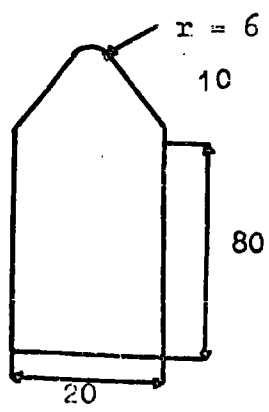
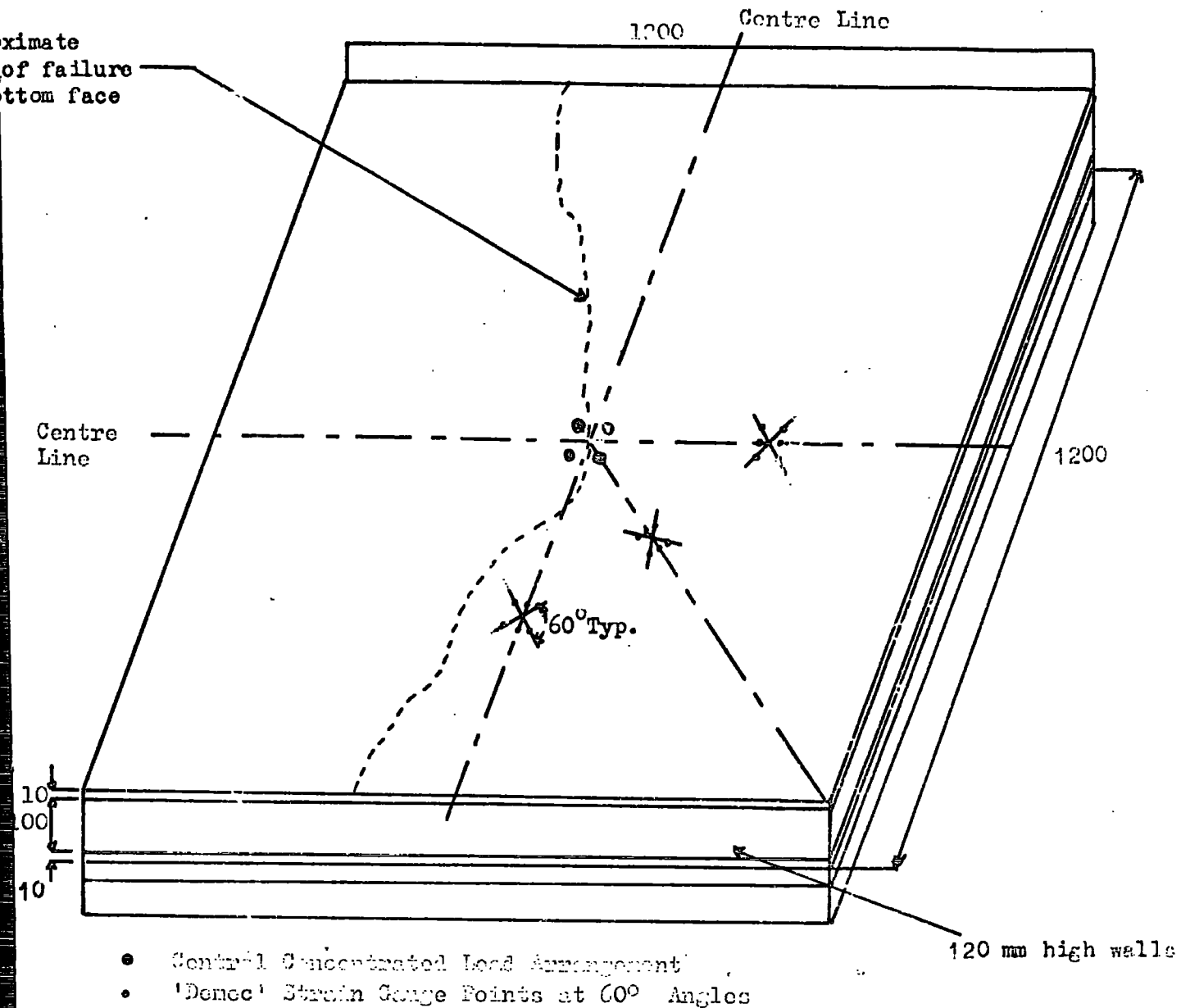

Section X. A
Details of Knife Edge Supports

FIGURE 4.22 Loading Of The Sandwich Slab.

4. Discussion:

The results are tabulated in Figures 4.20, 21 and plotted in Figures 4.16,19. The difference between the actual and experimental values are within the experimental error limits due to inaccuracy of the machinery, assumptions of the finite element analysis program i.e., the rotations are not fixed between the elements, therefore a discontinuity of the curvature of the element boundaries occur. But the main cause of the difference of the theoretical and experimental values occurs due to the fact that in reality the section does not behave either as a whole or the faces behave separately. The present author believes that this behaviour is somewhere in between due to the weak bond of the faces to the core.

The principal stresses measured do not represent any actual strains and stresses. Since the strains were in the order of 10^{-5} the strain values were already in the error limits of the strain gauges. Therefore they do not represent any actual values. Even if the expected strain were of a reasonable order, a high percentage of error is expected between the actual and experimental values.

Considering the points discussed in section 4.4, the displacement values are within acceptable limits. This suggests that the stress values calculated in the finite element analysis should give a reliable guide to stress and strain levels in the prototype slab.

The unexpectedly high failure load might be due to the Dexian frame being welded on the corners. This might have limited the tensile strains of the bottom face and caused cracks not to extend, therefore increasing the reinforcement snap load, because when the reinforcement failed the Dexian frame corner weld failed. The first observed crack was in the region of the expected load.

CHAPTER 5

CONCLUSIONS

At present, concrete is generally avoided in constructing sandwich sections; but the easy availability and cheapness of concrete relative to other materials should force future sandwich research workers to look into the possibilities of constructing concrete sandwich sections.

In this research a possible way of constructing cement-based sandwich sections is investigated. Some methods of pouring have been developed, and other methods of pouring have been given in the references.

Also the structural property values of the material are calculated with the results of the experiments. They have been checked at a later stage with simple theory and 'Finite Element Analysis'. The values are found to be correct within the experimental error limits.

Relevant theories to analyze the sections are given with modifications to suit the undertaken investigation.

There is a great deal of work to be done theoretically and practically to achieve an easy commercial use of the cement based sandwich sections such as roof slabs, walls, and load carrying members, i.e. beams and columns.

The poor adhesion and cohesion of cement requires further investigations to increase the bond between the core and the faces.

The irregularities of the thickness of the faces and the compaction of the core can be easily overcome by neat workmanship, experience, and advanced type of moulds in case of mass productions.

The following topics are suggested for the continuation of the present study :

- i) The effect of the web reinforcement on the stability of the core of sandwich sections in bending,
- ii) Heat and noise transfer of the sandwich panels,
- iii) Shear strength between the layers of sandwich sections,
- iv) Study of the location of the neutral axis and effective compressive and tensile zones with varying reinforcement in the faces.

APPENDIX I

DETAILS OF MOULDS

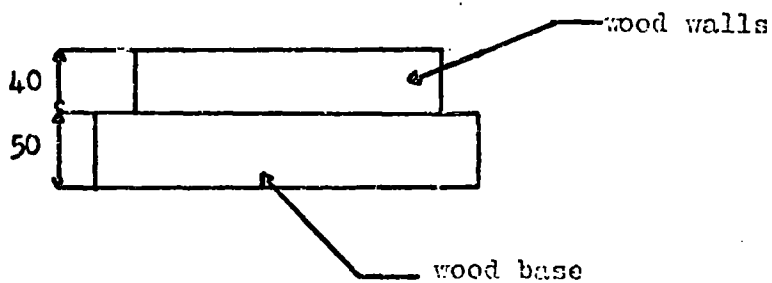
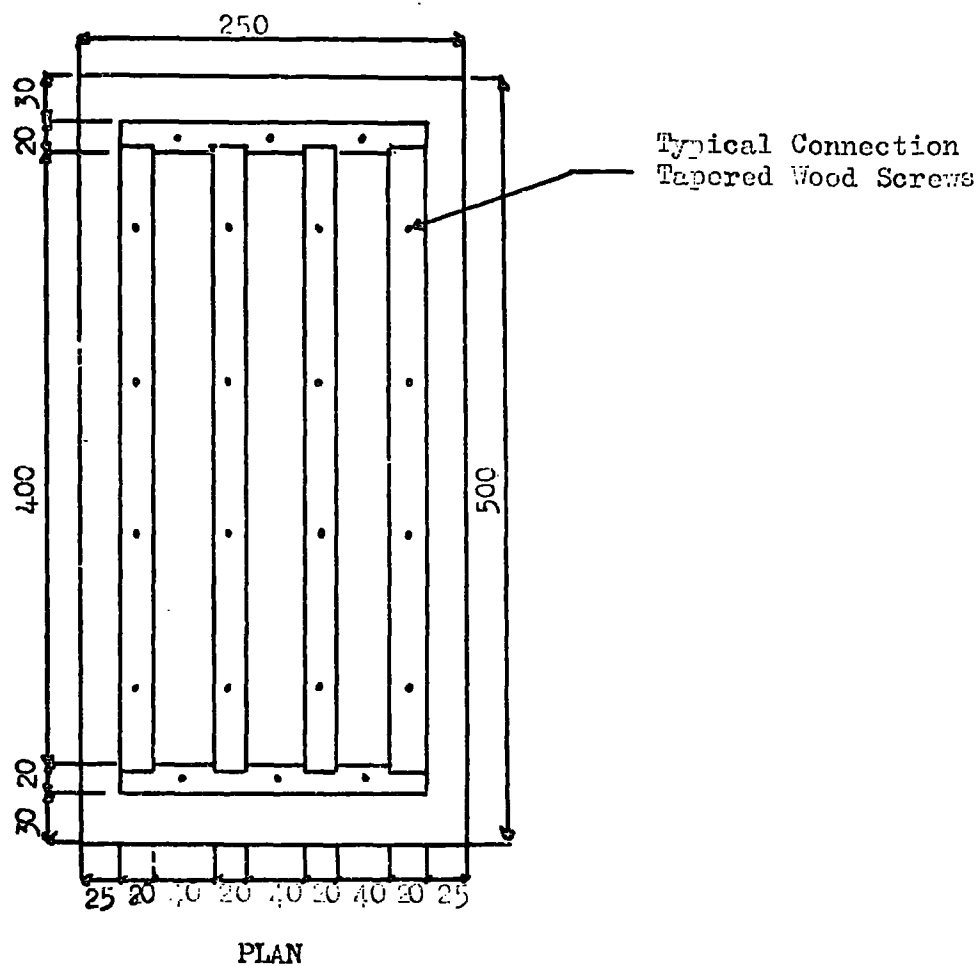

FIGURE A.1.1

Details of core sample moulds

Scale 1:5

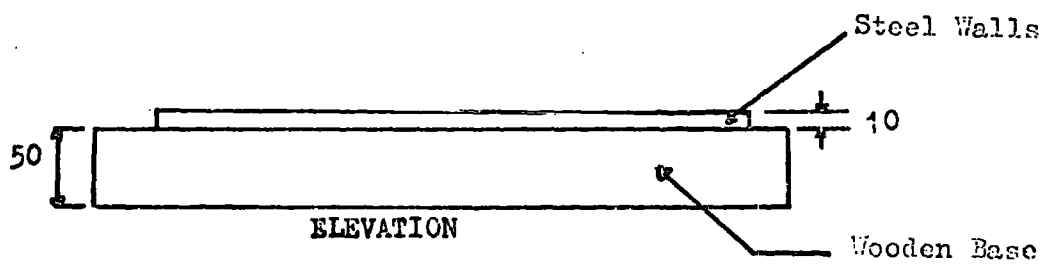
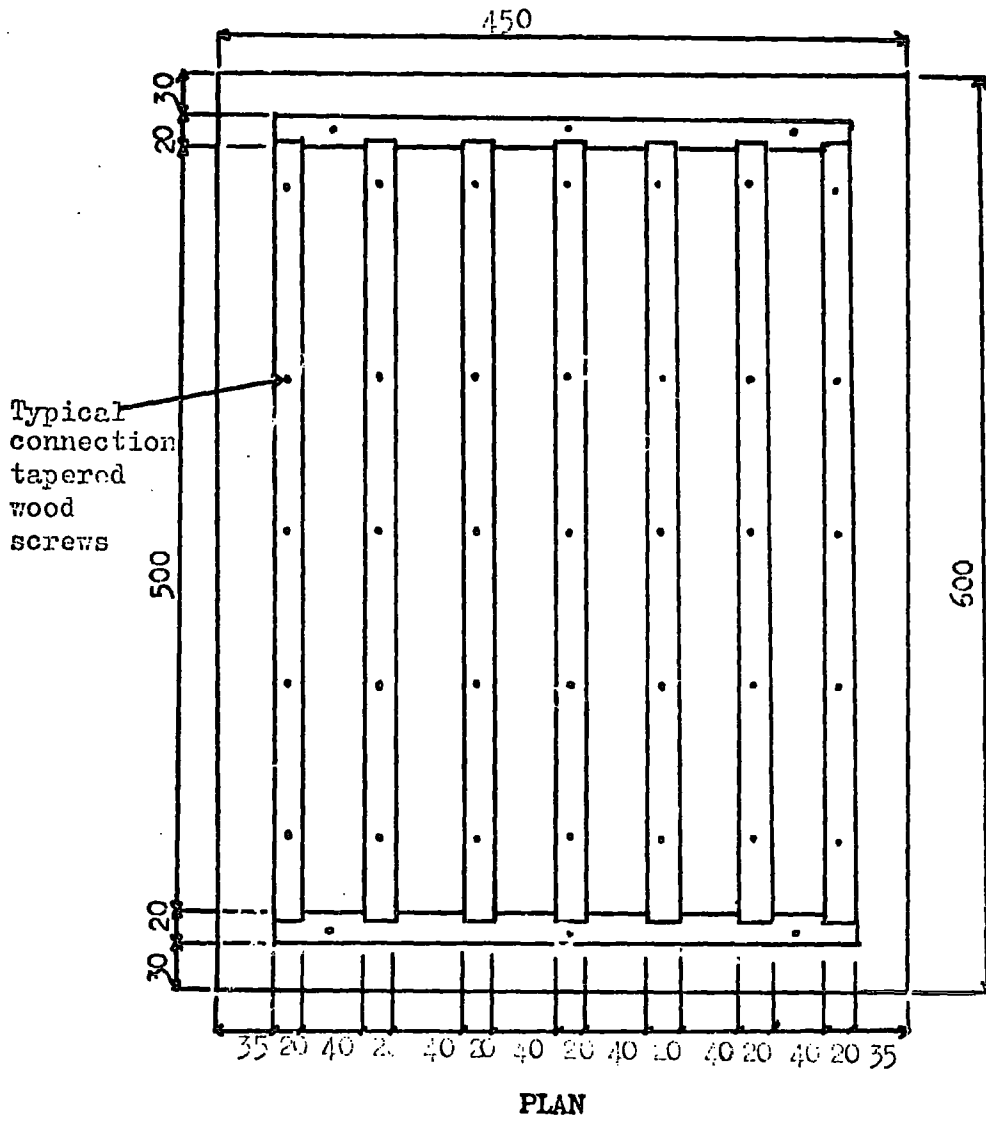
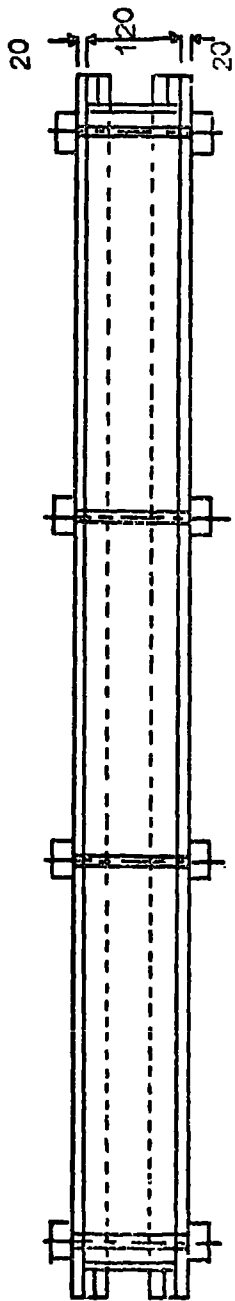

FIGURE A.1.2

Scale 1:5

Details of fibre reinforced sample
Moulds



PLAN

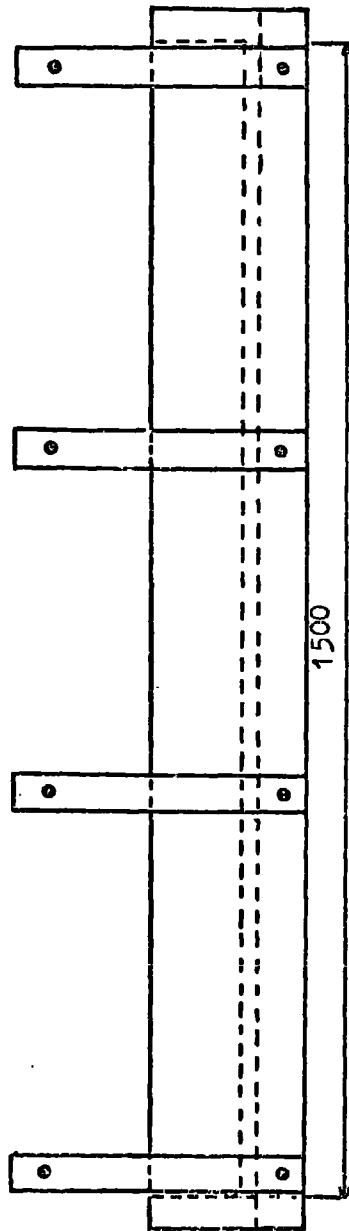

SIDE ELEVATION

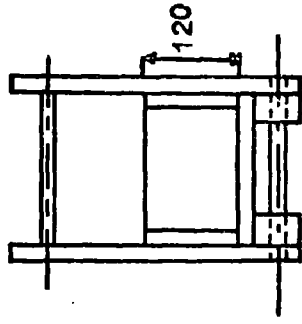

FRONT ELEVATION

FIGURE A.1.3 Details of Beam Moulds

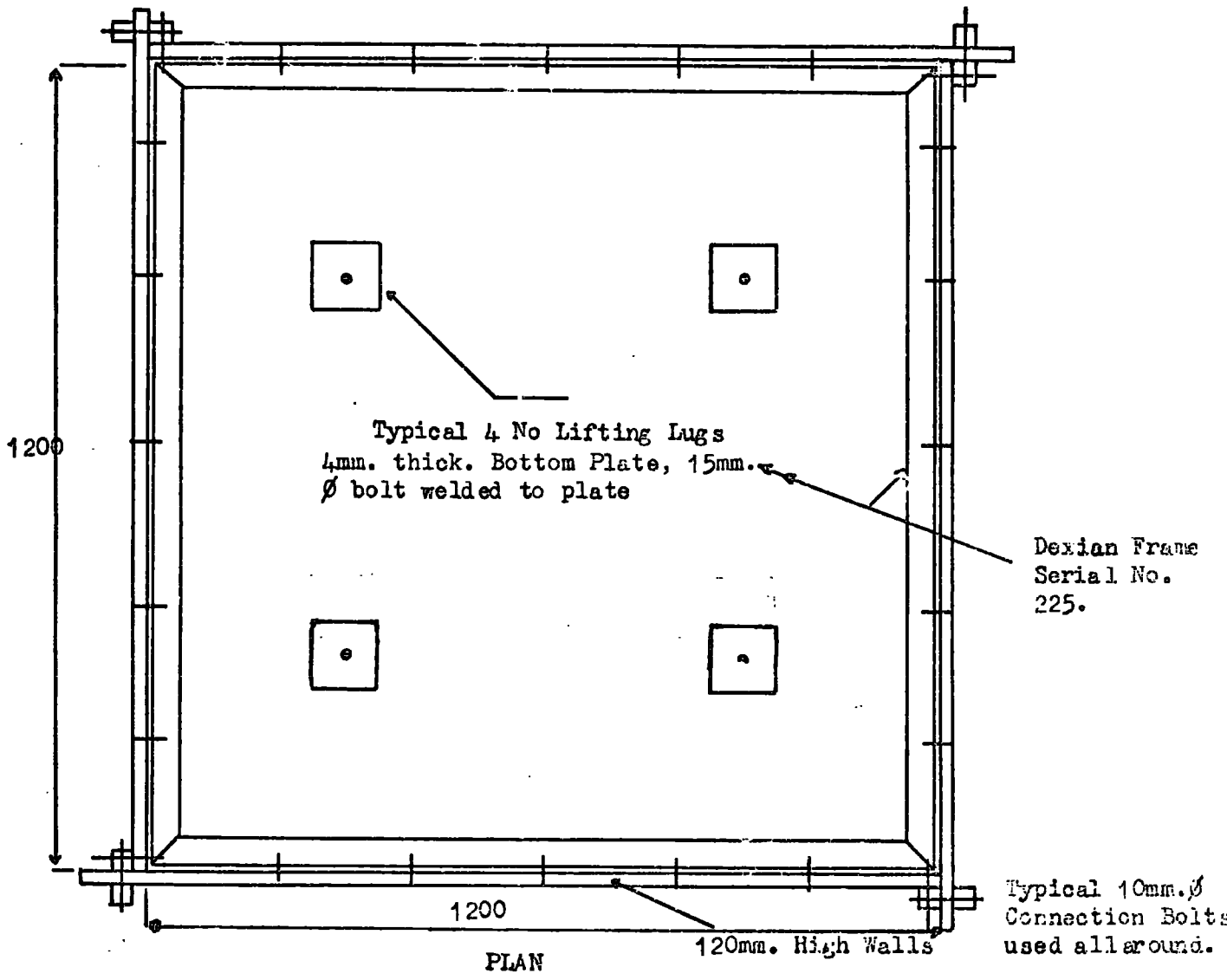

FIGURE A.1.4 Details Of Slab Formwork

APPENDIX II

COMPUTER INPUT AND OUTPUT

FOR BEAM FINITE ELEMENT ANALYSIS

DISPLACEMENTS, ELEMENT 20

0.12735D-19 0.50860D-06 0.23039D-03-0.43726D-21-0.50860D-06
 0.58555D-05-0.20425D-05 0.22517D-03-0.58555D-05 0.20425D-05
 0.12957D-19 0.13692D-19 0.23248D-03 0.48326D-20-0.26267D-20
 0.25941D-05-0.19515D-05 0.22517D-03-0.29441D-05 0.19515D-05
 0.44487D-05 0.45578D-06 0.22517D-03-0.44487D-05-0.45578D-06

0.42724D-20-C.35505D-05 0.23427D-03 0.55740D-20 0.39305D-05
 0.67245D-01-0.67245D-01 0.55349D-01-0.13280D-01-C.55349D-01
 0.13280D-01 0.37622D 00-0.37622D 00

STRESSES

-0.52406D 03-0.68454D 01 0.14659D 02 0.52406D 03 0.68494D 01-0.14659D 02

DISPLACEMENTS, ELEMENT 19

0.11869D-04-0.43601D-05 0.21341D-03-0.11869D-04 0.43601D-05
 0.12957D-19 0.13692D-19 0.23248D-03 0.48326D-20-0.26267D-20
 0.58555D-05-0.20425D-05 0.22517D-03-0.58555D-05 0.20425D-05
 0.56390D-05-0.62550D-06 0.22856D-03-0.56390D-05 0.62550D-06
 0.44487D-05 0.45578D-06 0.22856D-03-0.44487D-05-0.45578D-06
 0.95859D-05-0.42802D-05 0.22144D-03-0.95859D-05 0.42802D-05

STRESSES

-0.71363D 03 0.63680D 01-0.27890D 02 0.71363D 03-0.63680D 01 0.27890D 02

DISPLACEMENTS, ELEMENT 18

0.58555D-05-0.20425D-05 0.22517D-03-0.58555D-05 0.20425D-05
 0.16467D-04-0.70454D-05 0.18301D-03-0.16467D-04 0.70454D-05
 0.11869D-04-0.43601D-05 0.21841D-03-0.11869D-04 0.43601D-05
 0.11869D-04-0.60838D-05 0.21221D-03-0.11869D-04 0.60838D-05
 0.14386D-04-C.54025D-05 0.20192D-03-0.14386D-04 0.54025D-05
 0.95859D-05-0.42802D-05 0.22144D-03-0.95859D-05 0.42802D-05

0.58555D-05-0.20425D-05 0.22517D-03-0.58555D-05 0.20425D-05
 0.17467F-04-0.70454D-05 0.18301D-03-0.16467D-04 0.70454D-05
 0.11809D-04-0.43601D-05 0.21841D-02-0.11869D-04 0.43601D-05
 0.11809D-04-0.60836D-05 0.21221D-03-0.11809D-04 0.60836D-05
 0.14386D-04-C.54025D-05 0.20192D-03-0.14386D-04 0.54025D-05
 0.58559D-05-0.42802D-05 0.22144D-03-0.95860D-05 0.42802D-05

STRESSES

--0.66471F 03-0.22382D 02 0.10293D 03 0.66471D 03 0.22382D 02-0.10293D 03

DISPLACEMENTS, ELEMENT 17

0.18673D-04-0.72046D-05 0.17761F-03-0.18673D-04 0.72046D-05
 0.11809D-04-0.43601D-05 0.21841D-02-0.11869D-04 0.43601D-05
 0.16467D-04-0.70454D-05 0.18301D-03-0.16467D-04 0.70454D-05
 0.14897D-04-0.46891D-05 0.20382D-03-0.14897D-04 0.46891D-05
 0.14386D-04-0.54025D-05 0.20192D-03-0.14386D-04 0.54025D-05
 0.17269D-04-0.65178D-05 0.18074D-03-0.17269D-04 0.65178D-05

STRESSES

--0.40808D 03-0.11317D 02-0.25481D 02 0.40808D 03 0.11317D 02 0.25481D 02

DISPLACEMENTS, ELEMENT 16

0.16467D-04-C.70454D-05 0.18301D-03-0.16467D-04 0.70454D-05
 0.21207D-04-0.67256D-05 0.12956D-03-0.21207D-04 0.67256D-05
 0.18673D-04-0.72046D-05 0.17781D-03-0.18673D-04 0.72046D-05
 0.18644D-04-0.57383D-05 0.16817D-03-0.18644D-04 0.57383D-05
 0.20410D-04-0.72421D-05 0.15379D-03-0.20410D-04 0.72421D-05
 0.17269D-04-0.65178D-05 0.18074D-03-0.17269D-04 0.65178D-05

STRESSES

STRESSES

-0.380220 03 C.589370 01 0.412060 02 0.380220 03-0.589370 01-0.412060 02

DISPLACEMENTS, ELEMENT 15

0.230200-04-0.817030-05 0.123040-03-0.220200-04 C.817030-05
0.186730-04-0.720460-05 0.177810-03-0.186730-04 0.720460-05
0.212070-04-0.672560-05 0.129550-03-0.212070-04 0.672560-05
0.204270-04-0.623080-05 0.156350-03-0.204270-04 0.623080-05
0.204100-04-0.724210-05 0.153790-03-0.204100-04 0.724210-05
0.218030-04-0.707640-05 0.126600-03-0.218030-04 0.707640-05

STRESSES

-0.221550 03-0.877430 01-0.237210 02 0.221550 03 C.877430 01 0.237210 02

DISPLACEMENTS, ELEMENT 14

0.212070-04-0.672960-05 0.129560-03-0.212070-04 0.672960-05
0.242600-04-0.824610-05 0.680500-04-0.242600-04 0.824610-05
0.230200-04-0.817030-05 0.123040-03-0.230200-04 0.817030-05
0.224260-04-0.648560-05 0.111830-03-0.224260-04 0.648560-05
0.239910-04-0.863780-05 0.953640-04-0.239910-04 0.863780-05
0.218030-04-0.707640-05 0.126600-03-0.218030-04 0.707640-05

STRESSES

-0.257810 03 0.905380 01 0.413710 02 0.257810 03-0.905380 01-0.413710 02

DISPLACEMENTS, ELEMENT 13

0.255240-04-0.858760-05 0.607110-04-0.255240-04 C.858760-05
0.230200-04-0.817030-05 0.123040-03-0.230200-04 0.817030-05
0.242600-04-0.834610-05 0.680500-04-0.242600-04 0.834610-05
0.237580-04-0.727500-05 0.983520-04-0.237580-04 C.727500-05
0.239910-04-0.863780-05 0.953640-04-0.239910-04 0.863780-05
0.244460-04-0.756520-05 0.647700-04-0.244460-04 0.756520-05

STRESSES

-- 0.54727C 02-0.12229D 02-0.32293D 02 0.94727D 02 0.12229D 02 0.32253D 02

DISPLACEMENTS, ELEMENT 12

0.24260C-04-0.83461D-05 0.68C50D-04-0.24258D-04 0.83461D-05
 0.28514C-04-0.11926D-18-0.24826D-19-0.25311D-14 0.42369D-19
 0.25324D-04-0.89876D-05 0.60711D-04-0.25324D-04 0.89876D-05
 0.25714D-04-0.62723D-05 0.45C33D-04-0.25714D-04 0.62733D-05
 0.25664C-04-0.82655D-05 0.30937D-04-0.25684D-04 0.82655D-05
 0.24446D-04-0.75652D-05 0.64770D-04-0.24446D-04 0.75652D-05

0.675C8D-01 0.35555D 0C 0.67508C-01

STRESSES

-- 0.19568D 03 0.25047D 02 0.45281D 02 0.19568C 03-0.25047D 02-0.45281D 02

DISPLACEMENTS, ELEMENT 11

0.23380C-04-0.292C7D-05-0.20236D-20-0.23380D-04 0.292C7D-05
 0.25324D-04-0.89876D-05 0.60711D-04-0.25324D-04 0.89876D-05
 0.28514D-04-0.11926D-18-0.24826D-19-0.28514D-04 0.43369D-19
 0.24120C-04-0.71517D-05 0.24186D-04-0.24120D-04 0.71917D-05
 0.25684D-04-0.82655D-05 0.30937D-04-0.25684D-04 0.82655D-05
 0.25664D-04-0.18129D-05-0.160C7D-20-0.25664D-04 0.18129D-05
 0.59740D-01 0.12226C-01

STRESSES

0.43898D 02-0.26167D 01-0.26138D 02-0.43898D 02 0.26167D 01 0.26138D 02

DISPLACEMENTS, ELEMENT 10

0.12735D-19 0.50860C-06 0.23C39D-03-0.43726D-21-0.50860D-06
 0.58555D-05-0.20425D-05 0.22517D-03-0.58555D-05 0.20425D-05

DISPLACEMENTS, ELEMENT 10

0.12735D-19 0.50860D-06 0.23039D-03-0 0.43726D-21-0 0.50360D-06
 0.58555D-05-0 0.20425D-05 0.22517D-03-0 0.58555D-05 0.20425D-05

0.44777D-20 0.20938D-19 0.23037D-03-0 0.41905D-20 0.70429D-19
 0.25941D-05-0 0.19515D-05 0.22593D-03-0 0.25941D-05 0.19515D-05
 0.30175D-05-0 0.18112D-05 0.22893D-03-0 0.30175D-05 0.18112D-05
 0.31915D-05-0 0.15610D-05 0.22915D-03-0 0.31915D-05 0.15610D-05
 0.14775D 00 0.21680D-01-0 0.16775D 00-0 0.21680D-01

STRESSES

-0.11583D 03-0 0.64812D 01 0.54181D 02 0.11583D 03 0.64812D 01-0 0.54181D 02

DISPLACEMENTS, ELEMENT 9

0.88425D-05-0 0.95833D-05 0.22464D-03-0 0.88425D-05 0.95833D-05

0.44777D-20 0.20938D-19 0.23037D-03-0 0.41805D-20 0.70429D-19
 0.58555D-05-0 0.20425D-05 0.22517D-03-0 0.58555D-05 0.20425D-05
 0.25388D-05 0.23917D-05 0.22862D-03-0 0.29388D-05-0 0.23917D-05
 0.30175D-05-0 0.18112D-05 0.22893D-03-0 0.30175D-05 0.18112D-05

0.31915D-05-0 0.15610D-05 0.22915D-03-0 0.31915D-05 0.15610D-05

STRESSES

-0.21775D 03-0 0.24084D 02 0.14603D 02 0.21775D 03 0.24084D 02-0 0.14603D 02

DISPLACEMENTS, ELEMENT 8

0.58555D-05-0 0.20425D-05 0.22517D-03-0 0.58555D-05 0.20425D-05
 0.16467D-04-0 0.70454D-05 0.18301D-03-0 0.16467D-04 0.70454D-05

0.704540-05
 0.884250-05 0.958330-05 0.224640-03 0.664250-05 0.958330-05
 0.118090-04 0.608380-05 0.212210-03 0.118090-04 0.608380-05
 0.141270-04 0.821970-05 0.202800-03 0.141270-04 0.821970-05
 0.110660-04 0.114750-04 0.223520-03 0.110660-04 0.114750-04

STRESSES

--0.491870 03 0.419710 02--0.336240 02 0.491870 03--C.419710 02 C.336240 02

DISPLACEMENTS, ELEMENT 7

0.181740-04 0.836260-05 0.178680-03 0.181740-04 0.836260-05
 0.884250-05 0.958330-05 0.224640-03 0.884250-05 0.958330-05
 0.164670-04 0.704540-05 0.183310-03 0.164670-04 0.704540-05
 0.137480-04 0.742440-05 0.206270-03 0.137480-04 0.742440-05
 0.141270-04 0.821970-05 0.202800-03 0.141270-04 0.821970-05
 0.170580-04 0.747520-05 0.181170-03 0.170580-04 0.747520-05

STRESSES

--0.467770 03--0.101520 02--0.359290 02 0.467770 03 0.101520 02 0.359290 02

DISPLACEMENTS, ELEMENT 6

0.164670-04 0.704540-05 0.183010-03 0.164670-04 0.704540-05
 0.212070-04 0.672960-05 0.129560-03 0.212070-04 0.672960-05
 0.181740-04 0.836260-05 0.178680-03 0.181740-04 0.836260-05
 0.186440-04 0.573830-05 0.168170-03 0.186440-04 0.573830-05
 0.203410-04 0.761100-05 0.152950-03 0.203410-04 0.761100-05
 0.170580-04 0.747520-05 0.181170-03 0.170580-04 0.747520-05

STRESSES

--0.389990 03 0.150920 02 0.445500 02 0.389990 03--C.150920 02--0.445500 02

DISPLACEMENTS, ELEMENT 5

0.229430-04 0.828160-05 0.123170-03 0.229430-04 0.828160-05
 0.181740-04 0.836260-05 0.178680-03 0.181740-04 0.836260-05
 0.212070-04 0.672960-05 0.129560-03 0.212070-04 0.672960-05
 0.201830-04 0.668160-05 0.156740-03 0.201830-04 0.668160-05
 0.203410-04 0.761100-05 0.152950-03 0.203410-04 0.761100-05

0.22962D-04-0.82816D-05 0.12317D-03-0.22943D-04 0.82816D-05
 0.18174D-04-0.83626D-05 0.17868D-03-0.18174D-04 0.83626D-05
 0.21207D-04-0.67296D-05 0.12956D-03-0.21207D-04 0.67296D-05
 0.20183D-04-0.66816D-05 0.15674D-03-0.20183D-04 0.66816D-05
 0.20341D-04-0.76110D-05 0.15395D-03-0.20341D-04 0.76110D-05
 0.21777D-04-0.71805D-05 0.12665D-03-0.21777D-04 0.71805D-05

STRESSES

-0.23442D 03-0.79242D 01-0.34973D 02 0.23442D 03 0.79242D 01 0.34973D 02

DISPLACEMENTS, ELEMENT 4

0.21207D-04-0.67296D-05 0.12956D-03-0.21207D-04 0.67296D-05
 0.24260D-04-0.83461D-05 0.68050D-04-0.24260D-04 0.83461D-05
 0.22943D-04-0.82816D-05 0.12317D-03-0.22943D-04 0.82816D-05
 0.22426D-04-0.64856D-05 0.11183D-03-0.22426D-04 0.64856D-05
 0.23978D-04-0.86719D-05 0.95391D-04-0.23978D-04 0.86719D-05
 0.21777D-04-0.71805D-05 0.12665D-03-0.21777D-04 0.71805D-05

STRESSES

-0.25871D 03 0.59996D 01 0.42273D 02 0.25871D 03-0.99996D 01-0.42273D 02

DISPLACEMENTS, ELEMENT 3

0.25316D-04-0.89982D-05 0.60725D-04-0.25316D-04 0.89982D-05
 0.22943D-04-0.82816D-05 0.12317D-03-0.22943D-04 0.82816D-05
 0.24260D-04-0.83461D-05 0.68050D-04-0.24260D-04 0.83461D-05
 0.23768D-04-0.73216D-05 0.98403D-04-0.23768D-04 0.73216D-05
 0.23978D-04-0.86719D-05 0.95391D-04-0.23978D-04 0.86719D-05
 0.24443D-04-0.75748D-05 0.64776D-04-0.24443D-04 0.75748D-05

STRESSES

-0.97027D 02-0.12154D 02-0.32270D 02 0.97027D 02 0.12154D 02 0.32270D 02

-0.970270 02-0.121540 02-0.222700 02 0.070270 02 0.121540 02 0.322700 02

DISPLACEMENTS, ELEMENT 2

0.242600-04-C.834610-05 0.680500-04-0.242600-04 C.824610-05
 0.285140-04-0.119260-18-0.248260-19-0.285140-04 0.433650-19
 0.252160-04-0.899820-05 0.607250-04-0.253160-04 0.899820-05
 0.257140-04-0.627330-05 0.450330-04-0.257140-04 C.627330-05
 0.256830-04-0.826830-05 0.306400-04-0.256830-04 0.826830-05
 0.244430-04-0.757480-01 0.647760-04-0.244430-04 0.757480-05

STRESSES

-0.195830 03 0.251330 02 0.454290 02 0.195830 03-C.251330 02-C.454290 02

DISPLACEMENTS, ELEMENT 1

0.233780-04-0.291990-05-0.100380-19-0.233780-04 0.291990-05
 0.252160-04-0.899820-05 0.607250-04-0.253160-04 0.899820-05
 0.285140-04-0.119260-18-0.248260-19-0.285140-04 0.433650-19
 0.241170-04-0.719530-05 C.341910-04-0.241170-04 0.719530-05
 0.256830-04-0.826830-05 0.306400-04-0.256830-04 0.826830-05
 0.256630-04-0.181230-05-C.572960-20-0.256630-04 0.181230-05
 0.597810-01 0.122590-01

STRESSES

0.437180 02-0.261340 01-0.261320 02-0.437180 02 0.261340 01 0.261320 02

STOP 0
EXECUTION TERMINATED

\$SET LIBSRCH=OFF
\$SIG

APPENDIX III

COMPUTER INPUT AND OUTPUT

FOR SLAB FINITE ELEMENT ANALYSIS

0.653720-05-0.335480-05-0.400520-20-0.653720-05 0.336480-05
0.597430-05-0.587430-05 0.112330-04-0.587430-05 0.587430-05
0.127160-19-0.603250-05 0.8664430-20-0.234870-20 0.603250-05
0.606340-05-0.356560-05 0.886640-05-0.606340-05 0.356560-05
0.405680-05-0.405680-05 0.463370-05-0.405680-05 0.405680-05
0.423780-05-0.526540-05-0.655460-22-0.423780-05 0.536960-05
0.149120 00 0.178090-01-0.787420-01-0.178090-01-0.227280-02
0.122590 00-0.122590 00 0.160300 00-0.160300 00

STRESSES

--0.423570 02-0.151440 02-0.113450 03 0.423570 02 0.151440 02 0.113450 03

DISPLACEMENTS, ELEMENT 24

0.865430-05-0.221420-05 0.205320-04-0.865430-05 0.221420-05
0.822760-05-0.822760-05 0.383660-04-0.822760-05 0.822760-05
0.587430-05-0.587430-05 0.112330-04-0.587430-05 0.587430-05
0.811490-05-0.556710-05 0.338110-04-0.811490-05 0.556710-05
0.675010-05-0.675010-05 0.222470-04-0.675010-05 0.675010-05
0.685390-05-0.498060-05 0.991080-05-0.685390-05 0.498060-05
0.121130 00-0.121130 00 0.294500 00-0.294500 00

STRESSES

--0.308810 02-0.259850 02-0.204710 03 0.308810 02 0.259850 02 0.204710 03

DISPLACEMENTS, ELEMENT 23

0.865430-05-0.221420-05 0.205320-04-0.865430-05 0.221420-05
0.587430-05-0.587430-05 0.112330-04-0.587430-05 0.587430-05
0.653720-05-0.336480-05-0.400520-20-0.653720-05 0.336480-05
0.670800-05-0.226590-05 0.131530-04-0.670800-05 0.226590-05
0.685390-05-0.498060-05 0.991080-05-0.685390-05 0.498060-05
0.606340-05-0.356560-05 0.886640-05-0.606340-05 0.356560-05

STRESSES

DISPLACEMENTS, ELEMENT 22

0.82334D-05-0.84597D-04-0.83604D-20-0.82334D-05 0.84597D-06
 0.86543D-05-0.22142D-05 0.20532D-04-0.86543D-05 0.22142D-05
 0.65372D-05-0.23648D-05-0.60052D-20-0.65372D-05 0.33648D-05
 0.79467D-05-0.15224D-05 0.13089D-04-0.79467D-05 0.15224D-05
 0.67080D-05-0.22659D-05 0.13153D-04-0.67080D-05 0.22659D-05
 0.75194D-05-0.25242D-05 0.17121D-20-0.75194D-05 0.25242D-05
 0.21178D 00 0.22680D 00

STRESSES

-0.83182D 02-0.19058D 02-0.67046D 02 0.83182D 02 0.19058D 02 0.67046D 02

DISPLACEMENTS, ELEMENT 21

0.10830D-04-0.25597D-05 0.52673D-04-0.10830D-04 0.25597D-05
 0.10159D-04-0.10159D-04 0.72035D-04-0.10159D-04 0.10159D-04
 0.82276D-05-0.82276D-05 0.28356D-04-0.82276D-05 0.82276D-05
 0.10017D-04-0.65133D-05 0.66638D-04-0.10017D-04 0.65133D-05
 0.88208D-05-0.88208D-05 0.52103D-04-0.88208D-05 0.88208D-05
 0.91822D-05-0.62288D-05 0.35996D-04-0.91822D-05 0.62288D-05
 0.1F019D 00-0.18019D 00 0.43191D 00-0.43191D 00

STRESSES

-0.72051D 02-0.46690D 02-0.24333D 03 0.72051D 02 0.46690D 02 0.24333D 03

DISPLACEMENTS, ELEMENT 20

0.10830D-04-0.25597D-05 0.52673D-04-0.10830D-04 0.25597D-05
 0.82276D-05-0.82276D-05 0.33366D-04-0.82276D-05 0.82276D-05
 0.85543D-05-0.22142D-05 0.20532D-04-0.85543D-05 0.22142D-05
 0.87845D-05-0.41019D-05 0.43150D-04-0.87845D-05 0.41019D-05
 0.91822D-05-0.62288D-05 0.35996D-04-0.91822D-05 0.62288D-05
 0.81149D-05-0.55671D-05 0.33811D-04-0.81149D-05 0.55671D-05

STRESSES

0.54859D 02-0.22963D 02 0.14538D 02-0.54859D 02 0.22963D 02-0.14538D 02

DISPLACEMENTS, ELEMENT 19

0.108220-04 0.638910-06 0.307950-04-0.108220-04-0.638910-06
 0.108300-04-0.255970-05 0.526730-04-0.108300-04 0.255970-05
 0.855430-05-0.221420-05 0.205320-04-0.865430-05 0.221420-05
 0.103700-04 0.327950-07 0.440640-04-0.103700-04-0.327950-07

0.878450-05-0.410190-05 0.431600-04-0.878450-05 0.410190-05
 0.944280-05-0.432780-05 0.301840-04-0.944280-05 0.432780-05

STRESSES

-- 0.901950 02-0.606570 02-0.103700 02 C.901950 02 C.606570 02 0.103700 03

DISPLACEMENTS, ELEMENT 18

0.108220-04 0.638910-06 0.307950-04-0.108220-04-0.638910-06
 0.855430-05-0.221420-05 0.205320-04-0.865430-05 0.221420-05
 0.823340-05-0.845970-06-0.336040-20-0.823340-05 0.845970-06
 0.103150-04 0.215730-06 0.172450-04-0.103150-04-0.215730-06
 0.893340-05 0.436370-07 0.118010-04-0.893340-05-0.436370-07
 0.974000-05-0.637840-06 0.451750-05-0.974000-05 0.637840-06

STRESSES

0.752130 02 0.207060 01-0.321270 02-0.752130 02-0.207060 01 0.321270 02

DISPLACEMENTS, ELEMENT 17

0.102590-04 0.154410-05-0.551060-21-0.102590-04-0.154410-05
 0.108220-04 0.638910-06 0.307950-04-0.108220-04-0.638910-06
 0.823340-05-0.845970-06-0.336040-20-0.823340-05 0.845970-06
 0.103150-04 0.215730-06 0.172450-04-0.103150-04-0.215730-06
 0.893340-05 0.436370-07 0.118010-04-0.893340-05-0.436370-07
 0.974000-05-0.637840-06 0.451750-05-0.974000-05 0.637840-06
 0.417370 00

STRESSES

-- 0.765260 02-0.116550 02-0.549890 02 0.765260 02 0.116550 02 0.549890 02

0.13098D-04-0.13256D-05 0.92261D-04-C.13098D-04 0.13296D-05
 0.13098D-04-0.13058D-04 0.12776D-03-0.13098D-04 0.13058D-04
 0.10159D-04-0.10159D-04 0.72035D-04-0.10159D-04 0.10159D-04
 0.12199D-04-0.67005D-05 0.11449D-03-0.12199D-04 0.67005D-05
 0.11385D-04-0.11385D-04 0.94402D-04-0.11385D-04 0.11385D-04
 0.11334D-04-0.71621D-05 0.71531D-04-0.11334D-04 0.71621D-05
 0.38582D 00-0.38682D 00 0.56731D 00-0.56731D 00

STRESSES

- 0.19176D 02-0.82681D 02-0.33450D 03 0.19176D 02 0.82681D 02 0.33450D 03

DISPLACEMENTS, ELEMENT 15

0.13098D-04-0.13256D-05 0.92261D-04-C.13098D-04 0.13296D-05
 0.10159D-04-0.10159D-04 0.72035D-04-0.10159D-04 0.10159D-04
 0.10830D-04-0.25557D-05 0.52673D-04-0.10830D-04 0.25557D-05
 0.10624D-04-0.29387D-05 0.75207D-04-0.10624D-04 0.29387D-05
 0.11334D-04-0.71621D-05 0.71531D-04-0.11334D-04 0.71621D-05
 0.10017D-04-0.65133D-05 0.66608D-04-0.10017D-04 0.65133D-05

STRESSES

0.38320D 02-0.32757D 02 0.86643D 02-0.38320D 02 0.32757D 02-0.86643D 02

DISPLACEMENTS, ELEMENT 14

0.12263D-04 0.22955D-05 0.58830D-04-0.12263D-04-C.22955D-05
 0.13098D-04-0.13256D-05 0.92261D-04-0.13098D-04 0.13296D-05
 0.10830D-04-0.25557D-05 0.52673D-04-0.10830D-04 0.25557D-05
 0.11960D-04 0.26758D-06 0.76598D-04-0.11960D-04-C.26758D-06
 0.10624D-04-0.29387D-05 0.75207D-04-0.10624D-04 0.29387D-05
 0.11038D-04-0.74509D-06 0.51293D-04-C.11038D-04 0.74509D-06

STRESSES

- 0.383743D 02-0.54125D 02-0.18520D 03 0.383743D 02 0.54125D 02 0.18520D 03

DISPLACEMENTS, ELEMENT 12

0.12243D-04 0.22955D-05 0.59830D-04-0.12262D-04-0.22955D-05
 0.10830D-04-0.25597D-05 0.52675D-04-0.10830D-04 0.25597D-05
 0.10822D-04 0.63851D-04 0.30795D-04-0.10822D-04-0.63891D-06
 0.10592D-04 0.19337D-05 0.49496D-04-0.10582D-04-0.18337D-05
 0.11058D-04-0.74509D-04 0.51293D-04-0.11038D-04 0.74509D-06
 0.10370D-04 0.32795D-07 0.44094D-04-0.10370D-04-0.32795D-07

STRESSES

0.16486D 02-0.23176D 02 0.50295D 02-0.16486D 02 0.23176D 02-0.50295D 02

DISPLACEMENTS, ELEMENT 12

0.12310D-04 0.22183D-05 0.29690D-04-0.12310D-04-0.32183D-05
 0.12243D-04 0.22955D-05 0.59830D-04-0.12262D-04-0.22955D-05
 0.10822D-04 0.63851D-04 0.30795D-04-0.10822D-04-0.63891D-06
 0.11918D-04 0.24823D-05 0.44309D-04-0.11918D-04-0.24823D-05
 0.10582D-04 0.18337D-05 0.49496D-04-0.10582D-04-0.18337D-05
 0.11000D-04 0.20625D-05 0.25252D-04-0.11000D-04-0.20625D-05

STRESSES

-0.52220D 02-0.17101D 02-0.82205D 02 0.52220D 02 0.17101D 02 0.82205D 02

DISPLACEMENTS, ELEMENT 11

0.12310D-04 0.32183D-05 0.29690D-04-0.12310D-04-0.32183D-05
 0.10822D-04 0.63851D-06 0.30795D-04-0.10822D-04-0.63891D-06
 0.10259D-04 0.15441D-05-0.55106D-21-0.10259D-04-0.15441D-05
 0.10614D-04 0.18689D-05 0.22810D-04-0.10614D-04-0.18689D-05
 0.11000D-04 0.20625D-05 0.25252D-04-0.11000D-04-0.20625D-05
 0.10315D-04 0.21573D-06 0.17245D-04-0.10315D-04-0.21573D-06

STRESSES

0.53077D 02 0.16039D 02 0.66786D 02-0.53077D 02-0.16039D 02-0.66786D 02

DISPLACEMENTS, ELEMENT 10

0.12245D-04 0.25667D-05-0.92291D-21-0.12345D-04-0.25667D-05
 0.12310D-04 0.32183D-05 0.29690D-04-0.12310D-04-0.32183D-05
 0.10259D-04 0.15441D-05-0.55106D-21-0.10259D-04-0.15441D-05
 0.12251D-04 0.26855D-05 0.16173D-04-0.12251D-04-0.26855D-05

0.10259D-04 0.15441D-05 0.15106D-21 0.10259D-04 0.15441D-05
0.12251D-04 0.26855D-05 0.15173D-04 0.12251D-04 0.26855D-05

0.10614D-04 0.18689D-05 0.22810D-04 0.10614D-04 0.18689D-05
0.11715D-04 0.53182D-04 0.18341D-21 0.11715D-04 0.53182D-06
0.24258D 00 0.44363D 00

STRESSES

--0.12684D 03-0.16856D 02-0.25285D 02 0.12684D 03 0.16896D 02 0.25295D 02

DISPLACEMENTS, ELEMENT 9

0.14225D-04 0.22102D-19 0.13972D-03 0.14225D-04 0.12342D-19
0.23812D-19 0.95421D-19 0.21618D-03 0.76435D-20 0.42139D-19
0.13058D-04 0.13058D-04 0.12760D-03 0.13098D-04 0.13098D-04
0.93634D-05 0.42391D-19 0.19240D-03 0.93634D-05 0.31103D-19
0.11946D-04 0.11946D-04 0.17441D-03 0.11946D-04 0.11946D-04
0.13536D-04 0.49656D-05 0.12097D-03 0.13536D-04 0.49656D-05
0.27267D-01 0.27267D-01 0.40476D 00 0.76675D-01 0.40476D 00
0.76675D-01 0.37405D 00 0.37405D 00 0.76439D 00 0.76439D 00

STRESSES

--0.62499D 03-0.20157D 03-0.17949D 02 0.62499D 03 0.20157D 03 0.17949D 03

DISPLACEMENTS, ELEMENT 8

0.14225D-04 0.22102D-19 0.13972D-03 0.14225D-04 0.12342D-19
0.13098D-04 0.13098D-04 0.12776D-03 0.13098D-04 0.13098D-04
0.13098D-04 0.13256D-05 0.92261D-04 0.13098D-04 0.13256D-05
0.11591D-04 0.20252D-05 0.12004D-03 0.11591D-04 0.20252D-05
0.13536D-04 0.49656D-05 0.12097D-03 0.13536D-04 0.49656D-05
0.12199D-04 0.67005D-05 0.11449D-03 0.12199D-04 0.67005D-05

STRESSES

$\sigma_1 = -72$
 $\sigma_2 = -345.5$
 $\theta = 70^\circ$

DISPLACEMENTS, ELEMENT 7

0.12948D-04-0.20259D-20 0.27604D-04-0.12648D-04 0.62260D-20
 0.14225D-04 0.22102D-19 0.13972D-03-0.14225D-04 0.12342D-19
 0.12098D-04-0.13256D-05 0.52261D-04-0.13098D-04 0.13206D-05
 0.13254D-04 0.72666D-20 0.11785D-03-0.13254D-04 0.64678D-20
 0.11591D-04-0.20252D-05 0.12004D-03-0.11591D-04 0.20252D-05
 0.12744D-04 0.10937D-05 0.87463D-04-0.12744D-04-0.10937D-05
 0.37548D-01-0.37546D-01-0.73788D-01 0.73788D-01

STRESSES

-0.10076D 03-0.31351D 02-0.18212D 03 0.10076D 03 0.31351D 02 0.18212D 03

DISPLACEMENTS, ELEMENT 6

0.12943D-04-0.20255D-20 0.87804D-04-0.12948D-04 0.62260D-20
 0.13098D-04-0.13296D-05 0.92261D-04-0.13098D-04 0.13296D-05
 0.12263D-04 0.22955D-05 0.58830D-04-0.12263D-04-0.22955D-05

STRESSES

-0.10363D 02 0.53031D 01 0.66276D 02 0.10368D 02-C.53031D 01-0.66276D 02

DISPLACEMENTS, ELEMENT 5

0.12101D-04-0.22064D-20 0.54135D-04-0.12101D-04 0.67404D-20
 0.12948D-04-0.20253D-20 0.87804D-04-0.12948D-04 0.62260D-20
 0.12263D-04 0.22955D-05 0.58830D-04-0.12263D-04-0.22955D-05
 0.12271D-04 0.74754D-20 0.75780D-04-0.12271D-04 0.55602D-20
 0.11672D-04 0.21319D-05 0.81353D-04-0.11672D-04-0.21319D-05
 0.12517D-04 0.31663D-05 0.53534D-04-0.12517D-04-0.31663D-05
 0.51216D-01-C.51216D-01 0.38633D-01 0.38633D-01

$$\sigma_1 = 34.08$$

$$\sigma_2 = -3.72$$

$$\theta = -37.5^\circ$$

DISPLACEMENTS, ELEMENT 4

0.121010-04-0.220840-20 0.541350-04-0.121010-04 0.674040-20
 0.122630-04 0.229550-05 0.588300-04-0.122630-04-0.229550-05
 0.123100-04 0.221830-05 0.256900-04-0.123100-04-0.221830-05
 0.117090-04 0.290590-05 0.498510-04-0.117090-04-0.290590-05
 0.125170-04 0.316630-05 0.535340-04-0.125170-04-0.316630-05
 0.119180-04 0.248230-05 0.443090-04-0.119180-04-0.248230-05

STRESSES

-0.199210 02 0.143270 02 0.319660 02 0.199210 02-C.143270 02-0.319660 02

DISPLACEMENTS, ELEMENT 3

0.119160-04-0.385520-21 0.264270-04-0.119160-04 0.212460-20
 0.121010-04-0.220840-20 0.541350-04-0.121010-04 0.674040-20
 0.123100-04 0.321830-05 0.296900-04-0.123100-04-0.321830-05
 0.118400-04 0.389450-20 0.444560-04-0.118400-04 0.241180-21
 0.117090-04 0.290590-05 0.498510-04-0.117090-04-0.290590-05
 0.125820-04 0.327130-05 0.240710-04-0.125820-04-0.327130-05
 0.440250-01-0.440250-01 0.281530-01-0.381530-01

STRESSES

-0.782400 02 0.416290 02-0.152850 02 0.782400 02-0.416290 02 0.152850 02

-0.391
 ↑ 208
 ↑ 080

DISPLACEMENTS, ELEMENT 2

0.119160-04-0.385520-21 0.264270-04-0.119160-04 0.212460-20
 0.123100-04 0.321830-05 0.296900-04-0.123100-04-0.321830-05
 0.123450-04 0.256670-05 0.922910-21-0.123450-04-0.256670-05
 0.120800-04 0.202120-05 0.232120-04-0.120800-04-0.202120-05
 0.125820-04 0.327130-05 0.240710-04-0.125820-04-0.327130-05

STRESSES

0.122510-04 0.268550-05 0.161730-04-0.122510-04-0.268550-05

σ₁ = 2200
 σ₂ = -3600
 σ₃ = 1300

0.14867E 02 0.16070E 02-0.27382E 01 0.14862E 02-0.16070E 02 0.27382E 01

DISPLACEMENTS, ELEMENT 1

0.12757E-04 0.90489E-20-0.82606E-20-0.12757E-04-0.58377E-20
 0.11916E-04-0.28552E-21 0.26427E-04-0.11916E-04 0.21246E-20
 0.12345E-04 0.25667E-05-0.92231E-21-0.12345E-04-0.25667E-05
 0.12290E-04 0.44011E-20 0.17558E-04-0.12290E-04 0.31321E-20
 0.12080E-04 0.20212E-05 0.23212E-04-0.12080E-04-0.20212E-05
 0.13252E-04 0.11335E-05-0.41049E-21-0.13252E-04-0.11335E-05
 0.18992E-01 0.85276E-01-0.18992E-01 0.77578E-01-0.77578E-01
 0.30465E 00

STRESSES

0.14348E 03 0.27032E 02 0.22078E 02 0.14348E 03-0.27032E 02-0.22078E 02

STOP 0
 EXECUTION TERMINATED

\$SET LIBSRCH=OFF
 \$SIG

REFERENCES

1. Folie, G.M. "The Theory of Sandwich Panels Subjected To Transverse Loads Under Various Edge Conditions." Department of Civil Engineering, University of Southampton.
2. Blomquist, R.F. "Adhesives - Past, Present, And Future." A.S.T.M. 66th Annual Meeting, June 1963, A.S.T.M. Special Tech. Publication, No: 360 p.p.179 - 212.
3. Elliot, D.J. "The Structural Properties Of Flat Sandwich Panels." M.Sc. Thesis, Department of Engineering Science, University of Durham, 1970.
4. "A History Of Plastics Used In Structures Throughout The World." Plastics In Building, January 1965.
5. Parton, G.M. "The Structural Behaviour Of Polyhedral Sandwich Shells." Ph.D. Thesis, Department Of Engineering Science, University of Durham, 1975.

REFERENCES/continued

6. Jackson, J.R. Private Letter, Ref. JRJ/RL,
Vencel Resil Limited, Ocean
Works, Kent, 30th April, 1975.
7. Thiessen, G. U.S.A. Patent No: 3,021,291,
February 13th, 1962.
8. Sefton, C.R. U.S.A. Patent No: 3,214,393,
October 26th, 1962.
9. Sefton, C.R. U.S.A. Patent No: 3,272,765,
September 13th, 1966.
10. Sussman, V., Baumann H.G. "Expanded Polystyrene Beads
Lighten The Load." SPE Journal,
March 1972, Vol. 28 p.p. 18 - 21.
11. Lankard, D.R. "Fibre Concrete Applications."
Rilem Symposium, 1975. Fibre
Reinforced Cement And Concrete,
The Construction Press Limited,
1975.
12. Romualdi, J.P.,
Mandel, J.A. "Tensile Strength Of Concrete
Affected By Uniformly Distributed
And Closely Spaced Short Lengths
Of Wire Reinforcement." ACI Journal
Proceedings, Vol.61, No:6 June 1964
pp. 657 - 670.

REFERENCES/continued

13. "Fibre Reinforced Cement Composites."
Materials Technology Division Of The
Concrete Society, Technical Report
July, 1973, p. 28.
14. Romualdi, J.P.,
Batson, G.B. "The Behaviour Of Reinforced Concrete
Beams With Closely Spaced Reinforce-
ment." ACI Journal Proceedings Vol.
60. No.6 June, 1963, pp. 775 - 789.
15. McCurrich, L.H. "Fibres In Cement And Concrete."
Concrete Magazine April, 1973,
pp. 51 - 53.
16. Edgington J., Hannant D.S. "Steel Fibre Reinforced Concrete."
Williams, R.J.T. Building Research Establishment
Current Paper CP 69/74, July 1974.
17. Plantema, J.F. "Sandwich Construction."
John Wiley And Sons Inc., U.S.A.
1966.

REFERENCES/continued

- 18 Potma, T "Strain Gauges, Theory and Application"
N.V. Philips Netherlands, 1967
19. Desai, S.C., Abel, J.F.^o "Introduction to the Finite Element
Method" Litton Educational Publishing
Inc. Toronto, 1972
20. Allen, G.H. "Analysis and design of structural
sandwich panels" Pergamon Press Ltd
London 1969
21. Grimer, F.S. "The strength of cements reinforced
with glass fibres" Magazine of
Concrete Research Vol. 21, No. 66,
March 1969
22. Dixon, J. "Concrete reinforced with fibrous
wire" Concrete, March 1971
23. Romualdi, P.J.
Batson, B.G. "Mechanics of crack arrest in concrete"
Journal of the Engineering Mechanics
Division, Proceedings of the ACI,
June 1963
24. Holand, I.
Kolbein, B. "Finite Element methods in stress
Analysis" Tapir, Trondheim - Norway,
1970