

## Durham E-Theses

---

*Some aspects of the ecology of sesleria caerulea (l.)  
ard. subsp. calcarea*

Round-Turner, N.L.

### How to cite:

---

Round-Turner, N.L. (1968). *Some aspects of the ecology of sesleria caerulea (l.) ard. subsp. calcarea*, Durham e-Theses. <http://etheses.dur.ac.uk/8977/>

### Use policy

---

The full-text may be used and/or reproduced, and given to third parties in any format or medium, without prior permission or charge, for personal research or study, educational, or not-for-profit purposes provided that:

- a full bibliographic reference is made to the original source
- a [link](#) is made to the metadata record in Durham E-Theses
- the full-text is not changed in any way

The full-text must not be sold in any format or medium without the formal permission of the copyright holders.

Please consult the [full Durham E-Theses policy](#) for further details.



"Some aspects of the ecology of

Sesleria caerulea (L.) Ard. subsp. calcarea"

A dissertation submitted in  
partial fulfilment of the  
requirements for the degree  
of Master of Science in  
Ecology at the University  
of Durham.

by N. L. ROUND-TURNER.

Durham. September, 1968.

*N. Round-Turner.*



## CONTENTS

### ACKNOWLEDGEMENTS

### LIST OF TABLES

### LIST OF FIGURES

Chapter 1.	INTRODUCTION	p. 1
	Choice of Study	
	Taxonomy	p. 1
	Distribution	p. 2
Chapter 2.	THE AIMS AND SCOPE OF THE STUDY	p. 4
Chapter 3.	METHODS	p. 8
	Culture Techniques	
	The Culture Solution	p.14
	Field Studies	p.17
	Analysis	p.19
	a) Pedological studies	
	b) Field plant studies	p.21
	c) Culture plant studies	p.23
	d) Mineral analysis	p.23
Chapter 4.	RESULTS OF FIELD STUDIES	p.27
	Site Descriptions	
	Soil Analyses	p.29
	Plant Studies	p.31
	a) Morphology and anatomy	
	b) Calorific value	p.34
	c) Productive performance	
	d) Mineral analysis	p.35
Chapter 5.	RESULTS OF CULTURE EXPERIMENTS	p.41
	Productive Performance	
	Nutrient Dynamics - analyses	p.45
Chapter 6.	DISCUSSION	p.48
Chapter 7.	SUMMARY AND CONCLUSIONS	p.57

## ACKNOWLEDGEMENTS

Thanks are due to a large number of people who helped in many small ways, but only a few can be mentioned by name. Mr. Rose of the Botany Gardens gave much material assistance in the culture experiments. I am grateful to many technicians in the Departments of Botany and Zoology who have made contributions according to their particular line of duty and to members of the academic staff in both departments who have helped, advised and corrected. My greatest debt of gratitude is to my supervisor, Dr. D. J. Bellamy, without whose continuous support and encouragement I would have fallen by the way. Miss M. Handy, who has typed the work and successfully made sense out of hieroglyphics of dubious significance, I warmly thank. Finally, this research would not have been possible without the financial support of the Natural Environment Research Council.

List of Tables

Table I.	Composition of Culture Solutions
Table II.	Concentrations of Essential Ions in Culture Solutions
Table III.	Analysis of Soil Samples
Table IV.	Calorific Values of Plant Material
Table V.	Cassop Vale Field Crops
Table VI.	Upper Teesdale Field Crops
Table VII.	Analysis of Field Crops
Table VIII.	Analysis of Field Crops
Table IX.	Analysis of Field Material from Cassop Vale
Table X.	Cassop Vale Culture Plants - Production
Table XI.	Upper Teesdale Culture Plants - Production
Table XII.	Upper Teesdale Rowan Tree Site (Poa sp.) - Production
Table XIII.	Cassop Vale Culture Plants - Water Content
Table XIV.	Upper Teesdale Culture Plants - Water Content
Table XV.	Analysis of Culture Plants - Cassop Vale
Table XVI.	Analysis of Culture Plants - Upper Teesdale
Table XVII.	Analysis of Culture Plants - Upper Teesdale, Rowan Tree Site

## List of Figures

### Fig.

- 1) Distribution map of Sesleria caerulea.
- 2) Distribution map of Dryas octopetala.
- 3) Distribution map of Plantago maritima.
- 4) Layout of Cultures.
- 5) Soil Extraction apparatus.
- 6a and b) Climate Diagrams for Durham.
- 7a) Climate Diagrams for Durham.
- b) Climate Diagrams for Widdy Bank Fell.
- 8) Growth of field plants.
- 9) Mineral analysis of Cassop Vale field crops in mg./gm.
  - a) Ca
  - b) Mg
  - c) Na
  - d) K
- 10) Mineral analysis of Upper Teesdale field crops in mg./gm.
  - a) Ca
  - b) Mg
  - c) Na
  - d) K
- 11) Mineral analysis of Cassop Vale field crops in mg./plant.
  - a) Ca
  - b) Mg
  - c) Na
  - d) K
- 12) Mineral analysis of Upper Teesdale field crops in mg./plant.
  - a) Ca
  - b) Mg
  - c) Na
  - d) K
- 13) Cassop Vale Culture Plants - Production.
- 14) Upper Teesdale Culture Plants - Production.

## Chapter 1. INTRODUCTION

### Choice of study

The "Calcicole - Calcifuge" problem has perplexed ecologists for a long time and has stimulated a great deal of research. There is today a considerable volume of literature on the subject, none of which is entirely conclusive, but the authors have, almost unanimously, urged further research into the question particularly by means of plant culture under laboratory conditions. The present author's interest in the problem having been stimulated by the literature, it was decided to select a little known grass species of comparatively restricted distribution which has been defined by many authorities as a "calcicole" and to test, by culture experiments, its fidelity to this definition. Several people have conducted culture experiments on some of the more common grass species of the British Isles (Bradshaw et. al., 1958, 1960, 1964; Snaydon and Bradshaw, 1961; James, 1962; Jowett, 1959.) but, so far as is known, only one other worker, Zlatnik (1928), has made any study of Sesleria caerulea. Since this species is locally of some ecological importance, it was considered a worthwhile object for study.

### Taxonomy

The genus Sesleria, like many other plants, has a somewhat involved taxonomic history. The Index Kewensis of 1885



lists twelve species belonging to the genus from all over the world, with many subsequent additions in the periodic Supplements. Also listed are a confusing number of synonyms.

Hegi (1909) lists six species for Central Europe, one of which is Sesleria caerulea (L.) Ard. (= Cynosurus caeruleus L.), common name "Blaugras" or "Blaues Kopfgras". He also lists four subspecies or varieties:

- 1) subsp. calcarea Celak (= Aira varia Jacq.,  
= Sesleria calcaria Opiz, = S. varia Wettstein,  
= S. sadleriana Janka, = Cynosurus rupestris Wulf.)
- 2) var. pseudelongata Murr
- 3) var. angustifolium
- 4) subsp. uliginosa Celak, (= Sesleria uliginosa Opiz,  
= Cynosurus caeruleus L.)

The greatest confusion seems to arise from the fact that various authors have used a number of names for species, subspecies or variety denomination at various times.

Lowe (1865) ascribes the naming of this grass to Scopoli, who named the genus after the Italian botanist Sesler, the species name 'caerulea' meaning 'blue'. He also points out that this species is the equivalent to Cynosurus caeruleus of many authors. On this he is in agreement with Sowerby (c. 1862). The most recent authority is Hubbard (1968), who calls the plant under discussion (the only representative of the genus in the British Isles) Sesleria caerulea (L.) Ard. subsp. calcarea (Celak) Hegi, common name "Blue Sesleria" or "Blue Moor-grass". He

concludes his description of this plant with the following remarks:

"Sesleria caerulea has been divided into two groups, these being variously treated as distinct species, subspecies, or varieties; the British plant, mainly of dry calcareous soils, being known as S. calcarea Opiz or S. caerulea subsp. or var. calcarea, whilst the name S. caerulea has been restricted to the Scandinavian and E. and Central European grass of wet habitats."

#### Distribution

Sesleria caerulea is a native of France, Italy, Germany, Sweden and Iceland, where it occupies a variety of habitats from coastal to high mountain sites but is particularly common on limestone hills and mountains. In the British Isles Sesleria is a plant of marginal grasslands in the northern part of England, in Scotland and in Ireland (see Fig. 1). In England it is found in counties from Lancashire and Yorkshire northwards on limestone soils mainly in upland areas but also in lowland and coastal sites. In Scotland it is found on limestone and on mica-schists mainly in upland areas in Fifeshire, Kinross, Perthshire and Argyll. In Ireland it is found quite widely distributed on the Carboniferous Limestone in the west.

## Chapter 2. THE AIMS AND SCOPE OF THE STUDY

It was decided, for a number of reasons, to study two populations of Sesleria widely separated both geographically and ecologically. One was a lowland population on the Magnesian Limestone in Cassop Vale (grid ref. NZ341383), about five miles to the south-east of Durham city. This site lies at about 500 ft. O.D., but in comparison with the other site is a lowland, coastal environment. The second population studied was in an arctic-alpine environment on formations of the Carboniferous Limestone series in the Cow Green Reservoir site in Upper Teesdale, County Durham (grid ref. NY817295), lying at 1,600 ft. O.D.

The reasons for this choice were partly a question of convenience and partly ecological. Cassop Vale is the nearest Magnesian Limestone location to Durham where Sesleria grows in any quantity. There were no problems of access and, being largely waste ground, the site could be visited at any time and quantities of plant material and soil samples removed without difficulty. In Upper Teesdale the Department of Botany of Durham University already have a number of research sites as part of another study and since the Nature Conservancy exercise strict surveillance over the work done there it was necessary to confine my own work to within existing limits.

To turn to the ecological aspects of this study, as mentioned in the introduction nearly all the references to Sesleria caerulea in the various Floras and other literature describe it as a calcicolous plant of upland limestone areas. Hulten's (1950) map shows a marked correlation between the plant's distribution and that of "Kalksten" formations in North West Europe. Hegi (op. cit.) calls his subspecies calcarea "a true calcicole". Lowe (op. cit.) says that the favourite habitat of Sesleria is limestone rocks.

In the British Isles Sesleria shows a distinct bimodal distribution. It has the bulk of its populations on calcareous rocks in the arctic-alpine environment of our upland and higher mountain regions but also occurs in the lowlands and at sea level in a number of classic localities (e.g. The Burren and Black Head in Western Ireland) and at low altitudes in Teesdale where a number of arctic-alpine species are found, as it were, 'out of place'. Perhaps the most peculiar feature of its distribution in Britain is the abundance on outcrops of Magnesian Limestone on the coastal plain of Durham. Again the occurrence of a number of usually montane species (Heslop-Harrison, 1953) in the same area must be borne in mind.

Two other plants together match its distribution fairly well in some respects (see Figs. 2 & 3). Dryas octopetala,

Figures 1, 2 and 3

Distribution maps of Sesleria caerulea,  
Dryas octopetula and Plantago maritima

(reproduced from "Atlas of the British Flora")

By kind permission of the publishers,  
Thomas Nelson & Sons Ltd.

Fig.1

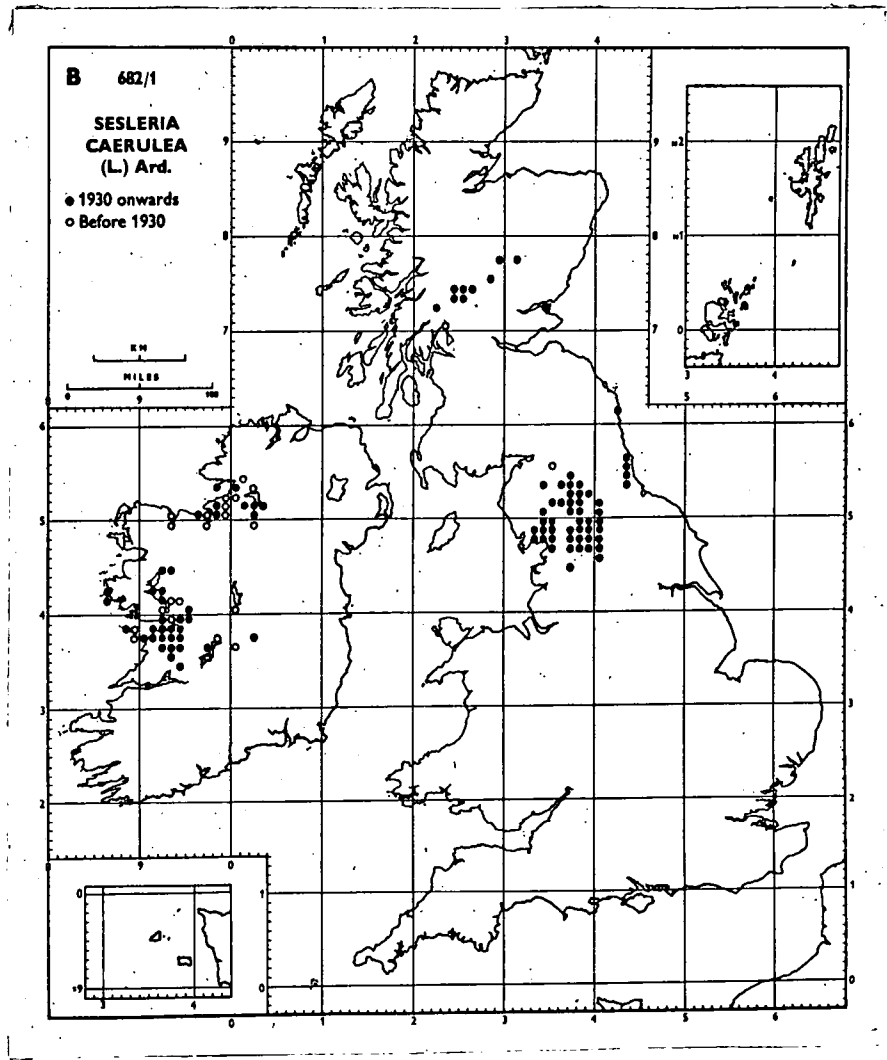

Fig. 2

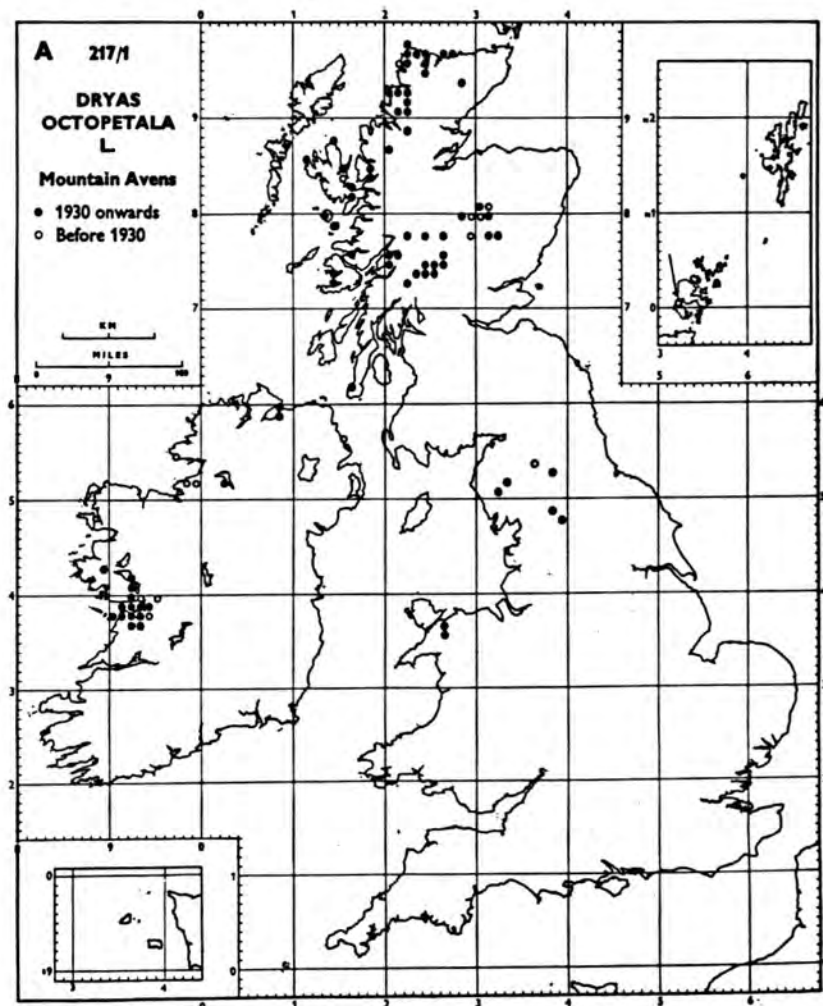
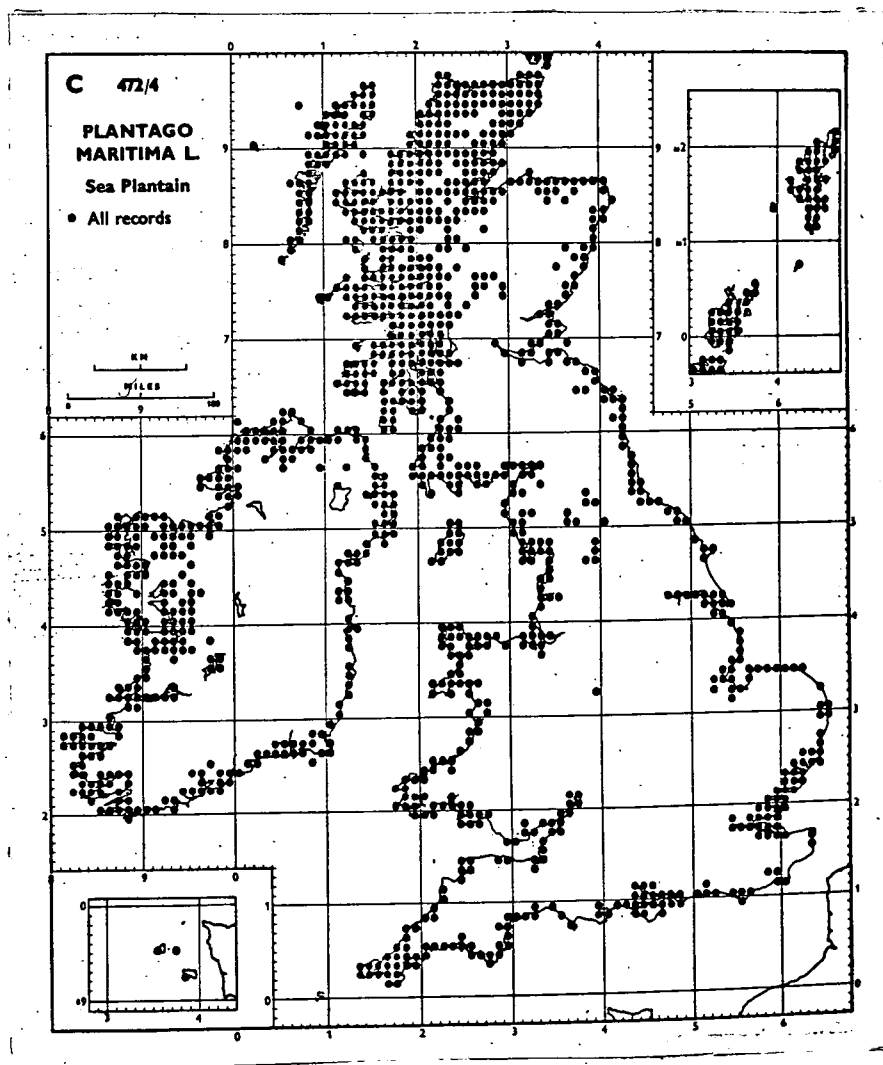

Fig. 3



an arctic-alpine species, has a very similar distribution in Britain but is absent from coastal Durham although it does occupy a few other coastal sites in spite of the inference behind its common name, the "Mountain Avens". Plantago maritima, bearing in mind its obvious preference for a coastal situation, matches *Sesleria*'s inland distribution almost exactly. Many examples could also be quoted of supposedly calcicole plants that also grow on non-calcareous soils, the enigmatic beech tree to name but one.

Two significant questions therefore pose themselves. What factor or factors determine the peculiar distribution pattern especially its absence from the great tracts of calcareous rocks in the south of England? What are the factors making it so successful in the few areas that it does occupy?

Its marked preference for the arctic-alpine environment immediately suggests intolerance of competition as the factor excluding it from areas with a more temperate climate. However, its abundance in certain lowland areas would indicate that at least in these sites some other factor (possibly edaphic) could be precluding growth of its competitors. If the latter is true then tolerance of the particular factor by *Sesleria* must be envisaged. The classic example of such a situation is *Plantago maritima* in which high salt concentrations on the coastal sites are supposed to keep out competitors, and a considerable tolerance by *P. maritima* for high levels of

sodium has been experimentally proved by Chapman (1960). In view of these problems it was decided to examine the plant in the light of the following three questions: Is it a Calcicole? Does it have a wide edaphic tolerance? How does its performance compare in the different environments? Taking the initial hypothesis that climate is the major factor in the arctic-alpine population and some edaphic factor in the lowland population, this was tested by dividing the study into two main branches. (1) The edaphic tolerances and nutrient dynamics of the plants were examined by culture experiments. (2) The performance of the plant in the field was measured by regular cropping and study of its nutrient dynamics. The experiments were conducted in as open-minded a manner as possible since, in view of the conflicting nature of the evidence, the hypothesis under examination was at best a nebulous one. It was hoped, therefore, that the scope of the study catered for as many eventualities as possible.

### Chapter 3. METHODS

#### Culture Techniques

It was unfortunate that the only available place in which to lay out the culture experiments was a hot-house in which were growing a magnificent collection of tropical flowering plants. This controlled environment glass house, or "Phytotron", was used by J. P. Rieley (1967) for his culture experiments on Carex spp. before the introduction of the tropical plants, and is equipped with thermostatic and hygrostatic apparatus as well as mercury vapour lamps with time-switches. For the present experiments the lamps were not used and the plants therefore experienced natural hours of daylight. Unfortunately, the plants also had to be subjected to temperatures which seldom fell below 70°F and on occasions rose to over 100°F while the Relative Humidity remained constantly high. As mentioned earlier, some of the plants in the experiment were from an arctic-alpine environment. That they survived at all under such extremely tropical conditions is in itself startling evidence of the tremendous hardiness of this species of grass.

A modified Long Ashton sand and water culture technique was used (Hewitt, 1952), with silver sand in plastic 3 inch and 3½ inch plant pots placed inside ordinary, household, rectangular polythene bowls. The use of plastic pots and polythene bowls was largely a matter of convenience as a plentiful supply of these articles was left from Rieley's work. Hewitt (ibid. p. 173)

warns of the danger of contaminants in plastic pots in the form of toxic plasticising compounds which can seriously jeopardise the success of plant seedlings. It was felt that this danger was not significant when the initial material consisted of tillers of vigorous, mature plants. The only real alternative was to use clay plant pots coated with bitumen to render them watertight and chemically inert (Hewitt, *ibid.*, p.172; Bradshaw, 1958), but this would have been expensive and time-consuming so, although it is a bad scientific axiom in the normal way, absolute safety was sacrificed for expediency.

Sand was selected as the plant sub-strate for a number of reasons. Rieley (*op. cit.*) used polythene chips and to prevent the development of algae he covered the pots and bowls with black polythene sheeting, the plants being inserted through small holes in this. However, the present author found that, because polythene chips float in water, the whole substrate tended to assume the stability characteristics of a floating mire. Furthermore, in view of the number of plants being grown it was felt that this method of preventing algal development was too difficult and it would be easier merely to scrape off the top layer of sand with the algae from time to time and replace it with fresh, clean sand. A straightforward water culture method was ruled out because of the amount of extra equipment needed to aerate the water and, again, because of the

difficulty of securing so many plants in the medium. Zlatnik (op. cit. p.20), who was working with fewer plants at a time, successfully used water culture, securing the plants and excluding the light from the culture medium (thus preventing algal development) by wedging them with cotton wool in holes in a lino cover. In the present experiment the excessive build-up of algae in the culture solutions was prevented by washing the bowls out and renewing the solution every fortnight.

The pots and polythene bowls were all thoroughly washed and scrubbed in hot water to render them physically 'clean' and then thoroughly rinsed in distilled water to remove all traces of chemical contaminants. The sand was likewise washed with distilled water and packed into the pots. Because the sand was so fine it was feared that it might leak out through the small drainage holes in the bottom of the pots. To prevent this the bottom of each pot was first lined with a quarter inch deep layer of polythene chips. The pots were numbered and arranged in the bowls which were labelled according to the treatment, one bowl per treatment. It was possible to fit nine of the smaller or six of the larger pots in each bowl, which measured 13 ins. x 10 ins. x 5 ins.

The plants for the culture experiments were collected from the two field sites and taken back to the laboratory for preparation. In the case of Cassop Vale large turfs were dug up and removed, but in Upper Teesdale this was not possible as

it would have disturbed the ground too much and the plants were more scattered here than in Cassop, where they form a solid carpet. It was therefore necessary to up-root the plants individually and with great care. In the laboratory individual healthy plants of as near a uniform size as possible were separated from the turf along with their roots. In this process some difficulty was experienced, in dealing with a tufted plant like Sesleria, in deciding what constituted an individual plant. Zlatnik (op. cit. p.19) had the same difficulty. The dead, outer leaves and sheath were then stripped off and any other dead material cut off. In the case of the Cassop Vale plants the leaves were then cut to a standard maximum length of 4 cm. from the collar, an action which, it later transpired, was a bad mistake as it adversely affected the success of the plant. The roots were likewise clipped to a fairly uniform, though not precise, length. The prepared tillers were washed in distilled water (special care being taken to remove all traces of soil particles from the roots), dried on filter paper and weighed. The plants were numbered and their weights recorded before they were planted in the sand. This was accomplished by gripping the tip of the root-stock in a pair of forceps and forcing it gently into the sand until the node at the base of the culm was just covered.

It was felt that thirty plants per treatment was an adequate number for the subsequent statistical treatment of the results so,

in order to allow a margin for plants that might die or fail to establish themselves, 36 plants per treatment was settled on. This meant that there were six plants per pot in the large ones (six pots per bowl) and four plants per pot in the small ones (nine pots per bowl). All the Cassop plants were in large pots and all the Teesdale plants in small pots. With all the treatments established (see below) this gave a grand total of 27 bowls and 972 plants. The Cassop plants, which were set up first (in the first week of March), were scattered randomly in the pots and labelled with small cardboard tags stapled round the culm. This method of labelling proved a failure as, if the labels came in contact with the wet sand they started to rot. It was then necessary to make a plan of each pot, marking the position of the numbered plants in them. When the Teesdale cultures were started at the beginning of May the plants were arranged round the pots in such a way that their numbers could be marked on the edge of the pots (see Fig. 4). The treatments were labelled alphabetically for convenience so that in the end every individual plant had a code number compounded of its number in the pot, the pot number, the treatment code letter and whether it was from Cassop Vale or Upper Teesdale. Thus, for example, CV/3/5/HB was the third plant in pot number five of the high magnesium treatment of Cassop Vale stock.

Figure 4

Layout of cultures

(figures denote numbered plants)

Fig. 4

Cassop Vale

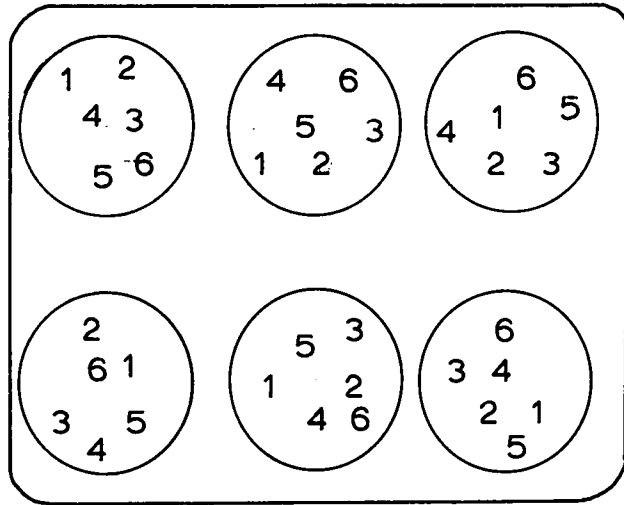

Upper Teesdale

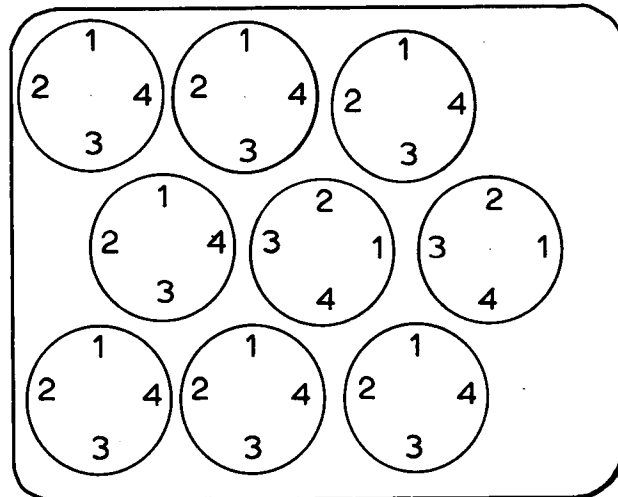

The choice of treatments was a difficult one. Ideally, of course, to test the response of a plant to any one element in a culture solution one should grow it in a series of different concentrations. However, because it was intended to test the response of Sesleria to a number of different nutrient elements, such experimental detail would have involved space, equipment and time in quantities that were simply not available. It was therefore necessary to simplify the experiment to a high and a low concentration of each element to be examined. In all except one case (see below) the low treatment merely involved the omission from the solution of the element concerned.

In the light of the introductory remarks of the first two chapters it was obligatory to test the plant's response to high and low levels of calcium and magnesium. To examine the possible effects of fertilizer applications in the field the Cassop Vale plants were also tested for response to high and low levels of nitrate and phosphate. It had been reported by other workers in Upper Teesdale that Sesleria had been found growing on the spoil heaps of old lead mines. This immediately suggested the possibility of edaphic ecotypes of Sesleria possessing a genetically evolved tolerance to otherwise toxic levels of lead and zinc in the soil. This phenomenon in other grass species has been the subject of a considerable amount of research (Bradshaw, 1952; Gregory and Bradshaw, 1965; Jowett, 1958, 1959, 1964; Wilins<sup>k</sup>, 1957, 1960.) (for discussion of this problem see chapter 6.)

Interesting possibilities were suggested by further research along these lines so the culture experiments were expanded to include high and low treatments of lead and zinc on both Cassop Vale and Upper Teesdale plants as well as a secondary population of plants collected from one of the lead spoil heaps in Upper Teesdale (this site being hereafter referred to as the "Rowan Tree Site" after the fact that a solitary tree of this species grew nearby). This part of the project was not the success that it might have been as, to the authors's intense chagrin, when the culture plants from the Rowan Tree site came into flower a few weeks after planting, they turned out not to be Sesleria caerulea at all but a species of Poa, probably P. pratensis. It is felt that this mistake was not entirely unforgivable as the two species are very hard to distinguish in the field by vegetative characteristics alone, especially when, as was the case, the specimens are very small. Similar taxonomic difficulties have been experienced by other workers in Upper Teesdale. It was decided, nevertheless, to continue with this part of the experiment and to attempt to incorporate the Poa plants into the work in some way.

#### The Culture Solution

The solution used was a modified Long Ashton solution (Hewitt, op. cit. p.189) based on that used by Rieley (op. cit.). The basic solution (see Tables I & II) contained all the essential elements for plant growth in the quantities shown

Table I. Composition of Culture solutions

Basic solution - control

salt	weight added. (gms.)	concentration. (mg./gm.)
KNO <sub>3</sub>	0.12928	103.424
Na <sub>2</sub> <sup>3</sup> HPO <sub>4</sub> .7H <sub>2</sub> O	0.40934	327.4752
Mg <sup>2</sup> SO <sub>4</sub> .7H <sub>2</sub> O	0.23616	188.928
Ferric citrate	0.01528	12.2304
MnSO <sub>4</sub> .4H <sub>2</sub> O	0.00285	2.2784
CuSO <sub>4</sub> .5H <sub>2</sub> O	0.000307	0.2458
ZnSO <sub>4</sub> .7H <sub>2</sub> O	0.000371	0.2969
H <sub>3</sub> BO <sub>3</sub>	0.002381	1.9046
(NH <sub>4</sub> ) <sub>6</sub> Mo <sub>7</sub> O <sub>24</sub> .4H <sub>2</sub> O	0.000045	0.0358
CaCl <sub>2</sub> .6H <sub>2</sub> O	0.105120	84.096

The treatments - additions and alterations

Treatment	Salt	weight added. (gms.)	concentration (mg./gm.)
+Ca	CaCl <sub>2</sub> .6H <sub>2</sub> O	1.08624	868.992
-Ca	omit CaCl <sub>2</sub>		
+Mg	MgCl <sub>2</sub> .6H <sub>2</sub> O	1.08624	868.992
-Mg	omit MgSO <sub>4</sub>		
+NO <sub>3</sub>	NaNO <sub>3</sub>	0.300576	240.4608
-NO <sub>3</sub>	omit KNO <sub>3</sub>		
	KCl	0.200384	160.3072
+PO <sub>4</sub>	Na <sub>2</sub> HPO <sub>4</sub> .7H <sub>2</sub> O	1.637376	1309.9008
-PO <sub>4</sub>	omit Na <sub>2</sub> HPO <sub>4</sub>		
+Pb	PbCl <sub>2</sub>	0.0372	29.76
-Pb	PbCl <sub>2</sub>	0.000372	0.2976
+Zn	ZnSO <sub>4</sub> .7H <sub>2</sub> O	0.14384	115.072
-Zn	omit ZnSO <sub>4</sub>		

Table II. Concentrations of essential ions  
in Culture solutions

Basic solution - control

ion	mg./gm.
Ca	15.38439
Mg	18.63987
Na	28.08378
K	39.9991
NO <sub>3</sub>	63.43339
PO <sub>4</sub>	116.01
B	0.33325
Fe	2.03883
Mn	0.56131
Cu	0.06254
Zn	0.06752
Mo	0.00028

The Treatments

Treatment	ion	mg./gm.
+Ca	Ca	158.9721
+Mg	Mg	122.5787
+NO <sub>3</sub>	NO <sub>3</sub>	238.7334
-NO <sub>3</sub>	K	84.0779
+PO <sub>4</sub>	PO <sub>4</sub>	464.05
+Pb	Pb	22.1723
-Pb	Pb	0.0222
+Zn	Zn	26.1629

and was used in its unaltered form for the control cultures. There were three sets of controls with 36 plants in each, two of Cassop Vale plants and one of Upper Teesdale plants. In preparing the solution for most of the other treatments it was simply a question of increasing the quantity of the relevant salt in high treatments or omitting it from low treatments. However, in the high magnesium treatment  $MgCl_2$  was added to the existing quantity of  $MgSO_4$  and both were omitted from the low treatment. In the high nitrate treatment  $NaNO_3$  was added to the existing quantity of  $KNO_3$  in order to avoid increasing the quantity of potassium. In the low nitrate treatment  $KNO_3$  was omitted and  $KCl$  was substituted to replace the lost potassium. In the high lead treatment a considerable quantity of  $PbCl_2$  was added to the basic solution and a much smaller amount was put in the low treatment since its total omission would merely duplicate the control conditions.

The solutions were made up in the following manner: each salt was weighed out in turn to an accuracy of a hundred-thousandth of a gram, dissolved in distilled water and made up to volume before storing in volumetric flasks. Fourteen burettes were set up on a lab. scaffolding frame, one for each of the constituent salt solutions. These were filled in the same sequence as that in which the salts are listed in Table I so that in making up each treatment the correct quantities of solutions could be rapidly run off in series into a conical flask.

The solution mixture was then made up to 1.25 litres with distilled water and poured into the bowls. This volume was maintained in the bowls by topping up with distilled water to replace the loss by evaporation.

The culture solutions were all maintained at pH 7 or just above, so that the reaction was neutral or slightly alkaline but never acid, by adding small quantities of sodium hydroxide or hydrochloric acid. Sodium hydroxide was always added in making up the high and low calcium and low phosphate treatments because these were known to be acid in reaction. On addition of NaOH small quantities of a white precipitate appeared, the significance of which was not immediately appreciated. Further research into the literature elicited the information that Zlatnik (op. cit. p.20) experienced the same phenomenon and he identified it as an insoluble precipitate of  $\text{CaSO}_4$ . He mentions that Tottingham (1914) had the same trouble although Olsen (1923), who used the same technique as Zlatnik, makes no mention of the precipitate. Zlatnik's plants in the cultures to which NaOH had been added soon showed signs of chlorosis and most of them died long before the experiments were concluded. Olsen attributed the death of his plants to an excess of OH ions. However, as Zlatnik points out, the precipitation of  $\text{CaSO}_4$  must seriously reduce the amounts of calcium available to the plants. As a result of this Zlatnik, who was concerned with the

performance of Sesleria spp. over a range of pH's, was unable to complete his experiments in the alkaline reaction range. Hewitt (op. cit.) discusses the regulation of pH in plant culture solutions in some detail. The significance of this problem in the present study will be discussed further in a later chapter.

The final volume of culture solution (1.25 litres per treatment) was decided upon after the experiment had been in progress for about three weeks. At first 2.5 litres were used. This volume meant that the level of solution in the bowls was almost up to the surface level of the sand in the pots. This caused an undesirable waterlogging effect and it was decided to reduce the depth of solution to about two inches by cutting the volume by half. The capillary effect of the sand was such that all the sand in the pot was kept moist. In retrospect it is felt that even this is too wet a condition for plants used to dry habitats and for future workers in this field it is recommended that either artificial aeration of the solution is provided or that another technique altogether (such as periodic watering of the plants with the solution) is used.

#### Field Studies

In the field the study sites were described and investigations made of their phytosociology. Soil samples were collected and taken back to the laboratory for analysis. The main field work, however, involved the initial collection of

plants for the culture experiments (see first section of this chapter) and for anatomical studies (see chapter 4), followed by the collection of crops at regular intervals of about four weeks. Cassop Vale could be visited whenever necessary but it was not possible to make perfectly regular visits to Teesdale as this depended on the availability of transport.

The first field crops were taken at the same time as the culture experiments were started so that the analyses would supply comparative data for the plants before and after culture treatment. For these first crops both above ground and below ground parts were collected but for all subsequent crops only aerial parts were collected. Thirty plants were cut off at the base of the culm and taken back to the laboratory. The greatest difficulty was in ensuring a perfect randomness of sample. Inevitably a certain element of subjectivity was subconsciously allowed to creep in. Perfectly random sampling is well nigh impossible when one is collecting individuals rather than cropping all the plants within a randomly selected quadrat. All the plants were stripped of dead material and weighed individually, numbered and dried to constant weight in an oven at 105°C before being weighed again to obtain dry weights and water loss. A 'crop' therefore represented the green biomass of thirty plants at any one time. Means and Standard Deviations were calculated for fresh weight, dry weight and percentage water content. Each crop was then stored for subsequent mineral analysis.

### Analysis

Mineral analyses and other laboratory studies were made of the soil samples, the plants collected in the field and, at the end of the culture experiments, of the culture plants. The final set of culture solutions at the end of two weeks use were also kept for analysis.

#### a) Pedological studies

Four sets of soil samples, from Cassop Vale, from two locations on the Upper Teesdale site, and from the Rowan Tree site respectively, were collected and spread out on newspaper in the laboratory to dry for about a week. The air-dried soil was then passed through a 2 mm. sieve to obtain a more uniform and smaller particle size. 10 gms. of each sample were then weighed out into porcelain crucibles and oven dried to constant weight at 105°C. The weight loss represented the weight of water in air-dry soil excluding, that is, chemically combined water and small amounts of water bound up in the humus and colloidal complexes. The rest of the air-dry soil was kept for mineral analysis and pH measurements. The latter were performed on an E.I.L. model 23A glass electrode Direct Reading pH Meter, the soil having first been wetted with distilled water to a thick muddy consistency.

Determinations of the organic matter content of the soil were made by the Peroxide Method. 10 gms. of each air-dried sample were weighed out and placed in tall 500 ml. beakers.

To the soil was added 50 ml. of 100 vol. strength hydrogen peroxide. The mixture was allowed to stand for five minutes then gently warmed on a sand bath in the fume cupboard and stirred continuously until the evolution of oxygen ceased. A further 50 ml. of  $H_2O_2$  was added and heated until frothing almost ceased. The samples were then allowed to cool before adding 20 ml. of 2N HCl (or more if necessary) to remove carbonates. When the acid reaction was completed the soil suspensions were filtered through a weighed Whatman No. 1 filter paper and washed thoroughly with distilled water to remove all traces of acid and peroxide. The filter papers plus mineral soil were then placed in the oven at  $80^\circ C$  to dry. They were then removed and allowed to cool before weighing. The new weight, after subtraction of the filter paper weight, was subtracted from the original 10 gms. to obtain the weight of organic matter and expressed as a percentage.

To extract the exchangeable cations 2.5 gms. of air-dried soil were leached with 250 ml. of N. ammonium acetate solution. The soil was placed in extraction thimbles inside separation tubes set up on a frame. To the bottom of these were attached, by means of short pieces of polythene tubing, S-tubes with a small hole in the top bend of each to prevent the extract from syphoning off. The ends of the S-tubes were inserted in the necks of 250 ml. volumetric flasks in which the extracts were collected. The ammonium acetate solution was

supplied from 250 ml. conical flasks by means of inverted U - tubes inserted through rubber stoppers. The syphoning rate was adjusted to 1-3 mls./minute by means of screwclamps on polythene tubes fitted to the outer end of the U - tubes. (see Fig. 5 for design of apparatus). This apparatus was used in preference to that used by Rieley (op. cit.) and others because the thimbles were more efficient filtrants than glass wool and there was no danger of soil particles escaping in the filtrate, thus obviating the necessity for subsequent filtration.

b) Field plant studies

A careful anatomical study was made of plants from both field sites. Although this would seem to bear little relation to ecology, indeed it is a line of investigation which few people seem to have pursued, it was felt that it might shed some light on possible ecotype differences. Transverse sections of fresh leaves were cut by hand and on a freeze-microtome and prepared in the usual way. Safranin stain was used to highlight cell structural components, especially sclerenchyma, and the mounted slides were examined on a Watson "Microsystem - 70" microscope.

Measurements of the calorific value of plants from Cassop and Teesdale were made and separate estimates made of leaves, stems and flowers on a Gallenkamp Adiabatic Bomb Calorimeter. The bomb was first calibrated with benzoic acid, which has a

Figure 5

Soil extraction apparatus

Fig. 5

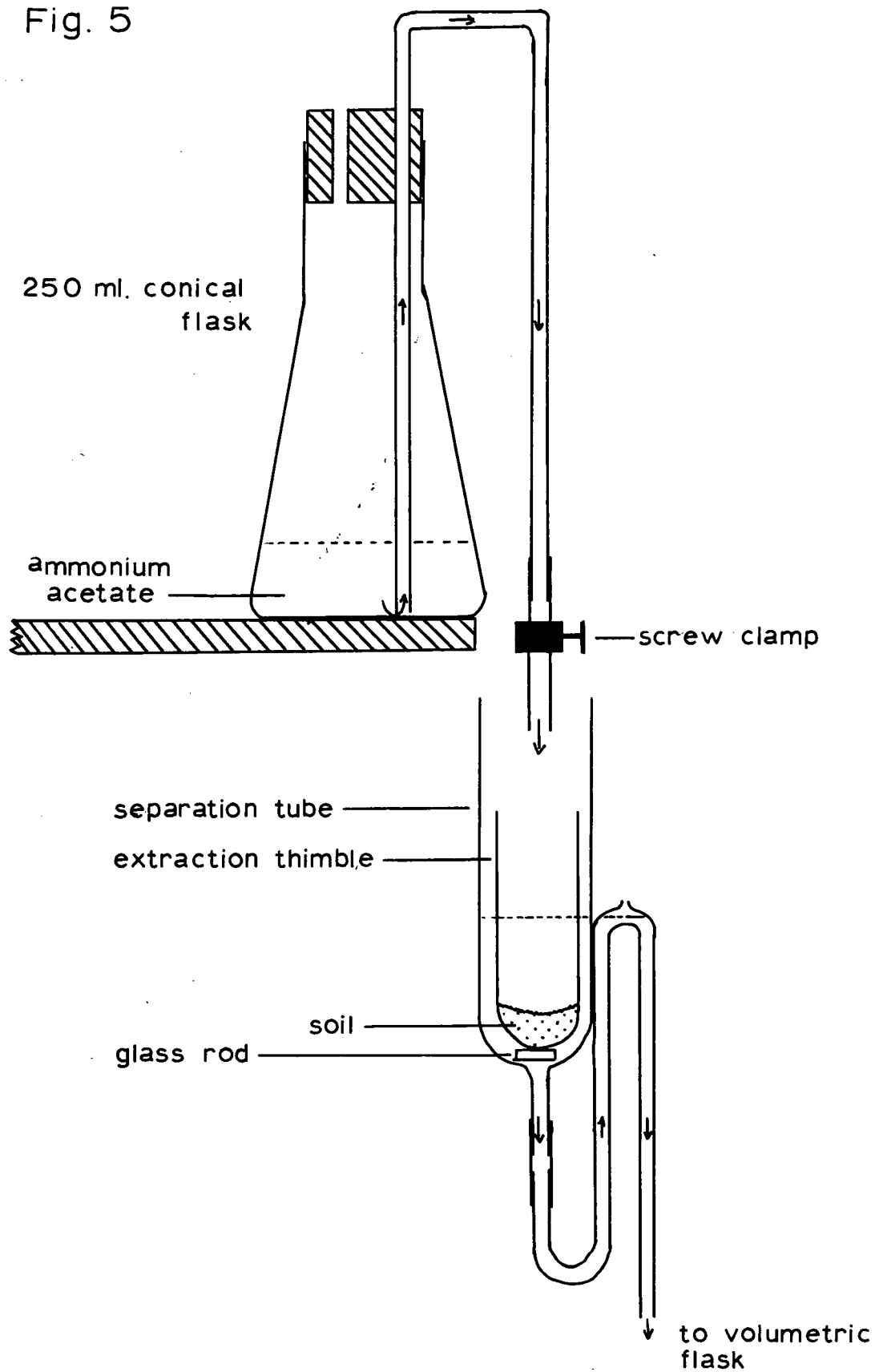

known calorific value, and then as many samples were bombed as there was material available. There is little point in giving details of bomb calorimetry here as this was not an important part of the study and was done merely to establish whether there was any significant difference in calorific value between plants of the two populations.

The main bulk of the work consisted of the preparation of plant digests for mineral analysis. The method used was that described by Jefferies and Willis (1964), with minor variations. The dried plant material was milled in an "Apex" cutter mill, weighed and transferred to conical flasks. No allowance was made for the possibility of contamination of samples in the mill but the most stringent precautions were taken in cleaning the mill with a small brush and jet of compressed air between each milling operation. To each flask was added a digesting mixture of 20 ml. conc. nitric acid, 5 ml. conc. hydrochloric acid and 5 ml. of 60% w/v perchloric acid. This was then heated on a sand bath in the fume cupboard and boiled until only a little perchlorate was left. If, at the end of this process, some plant material remained undigested, a further 20 ml. of  $\text{HNO}_3$  was added and boiled again. The digest was then allowed to cool and about 200 ml. of distilled water was added before filtering through a Whatman No. 1 filter paper to remove silica. The filtrates were made up to 250 ml. with distilled water and stored in labelled polythene bottles in the cold room.

c) Culture plant studies

The culture plants were treated in much the same way as the field plants. Leaves from plants in the control cultures were selected for anatomical studies to establish whether there had been any changes in cellular structure and distribution as a result of being grown in the phytotron under controlled conditions.

When the culture experiments were terminated the plants were removed from the pots, washed in distilled water to remove all sand particles and traces of culture solution and the roots separated from the shoots (in the case of Cassop plants) before weighing. Fresh and dry weights were again measured. In the case of Teesdale plants the weight of the whole plant had to be taken because it was found to be too difficult to separate the roots without losing some of the leaves. These were, however, separated from the dry plants before digestion and analysis. The digests were prepared in the same way as for the field plants. In most cases separate digests were prepared of shoots and roots but in some cases there was insufficient material for this so shoots and roots had to be mixed and digested together. This should be borne in mind when reviewing the results.

d) Mineral analysis

All the samples (plant digests, soil extracts and final culture solutions) were analysed for calcium, magnesium, sodium and potassium. It was originally intended to analyse for zinc

and phosphate as well, but in the case of the former the necessary auxiliary equipment was not immediately available and in the case of the latter there was insufficient plant material for the duplicate preparations that were required.

Calcium and magnesium were analysed by atomic absorption spectrophotometry (for discussion of this technique see David, 1958, 1959; Allen, 1958) on an EEL Atomic Absorption Spectrophotometer. Sodium and potassium were analysed by flame photometry using an EEL Model 'A' Flame Photometer. The principle of atomic absorption spectrophotometry is as follows: the solution being tested is atomised and delivered into a stream of air. It mixes with the acetylene gas fuel and when the mixture burns free atoms are formed. Pulsed light from a hollow cathode lamp, emitting the spectrum of the element to be determined, is passed through the flame and into a monochromator. The change in absorption at a particular wavelength is detected electronically and recorded. This change is caused by the presence of free atoms, so the degree of absorption is generally proportional to the number of atoms present. This technique was used in preference to ion-exchange chromatography because Rieley (op. cit.) tried both and found the former quicker, easier and more efficient.

100 p.p.m. stock solutions of  $\text{CaCO}_3$  and  $\text{MgCl}_2$  were prepared using analytical grade salts.  $\text{CaCO}_3$  was used instead of  $\text{CaCl}_2$  because of the extremely hygroscopic nature of the latter.

Calibration curves were constructed from series dilutions of the stock solutions. The extracts were then run through the machine, first for calcium and then for magnesium analysis. The scale readings were read off on the calibration curves in parts per million and converted to milligrams per gram of plant material or of soil or culture solution accordingly.

The Flame Photometer works on the principal that certain ions colour a gas flame. The degree of coloration is sensed by a photo-electric cell and converted to a scale reading by a galvanometer. By inserting a filter which cuts out all except the light emitted by the element in question the concentrations of the element can be measured. 100 p.p.m. stock solutions of NaCl and KCl were prepared and calibration curves constructed in the same manner as before.

There are many errors inherent in these techniques, largely due to interference between different elements. Some of these can be largely corrected for but perfect accuracy can only be ensured by a great deal of chemical 'manipulation'. As we are concerned here with comparative values it was felt that the degree of precision was not so important and that the slight improvement of results obtainable by a great deal more work would not justify the time involved. It should also be noted that half a gram is the minimum quantity of digested plant material regarded as sufficient to give acceptable results. In some cases this minimum was not available and the analyses

were therefore omitted. In other cases the results of slightly sub-minimal quantities have been included but should be regarded with some suspicion.

Plate 1

General view of Cassop Vale study site.

Plate 2

Close-up of study site.

Plate 3

Sesleria growing on Magnesian Limestone.

Note dense tussocks.

6 inch ruler for scale.



## Chapter 4. RESULTS OF FIELD STUDIES

### Site Descriptions

The Cassop Vale site was located in an old limestone quarry (see Plate 1). Sesleria grew in profusion on ledges on the quarry face and on the steeply sloping ground above the quarry. These sites were very well drained and the soil was a typical light, friable limestone soil, seldom more than nine inches deep and usually less than six inches. Because of the northerly aspect of the site the plants received less sun than they might otherwise have done and the soil was probably slightly damper and cooler than in a similar situation with a southerly aspect.

The climatic data for Durham can be applied to Cassop Vale as they are not far apart and the difference in height is insignificant. A comparison of Figs. 6(a) and 7(a) will show that there was an unusually high rainfall in July of this year and a peak in February while the January precipitation was lower than average. The February temperature fell to 34.3°F instead of the average of 38.1°F and the highest mean temperature came in June instead of July. The diagram for 1967 (Fig. 6(b)) has been included as the previous year's weather conditions are bound to have some effect on the performance of the plant in the following season.

Figures 6 and 7

Climate diagrams

(after Bellamy and Holland, 1966)

Note: Horizontal line indicates  $42.8^{\circ}\text{F}$  - minimum temperature for vegetative growth; number of days with mean temperature above this (i.e. length of growing season) is indicated.

Fig. 6(a)

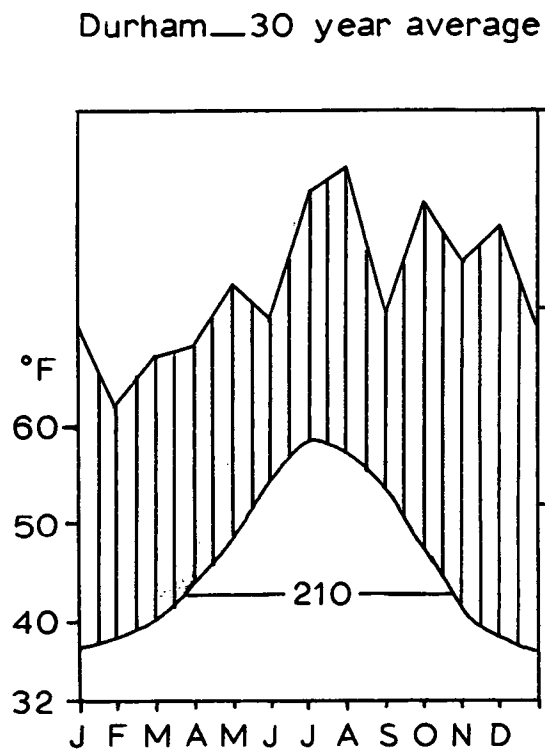

(b)

Durham—1967

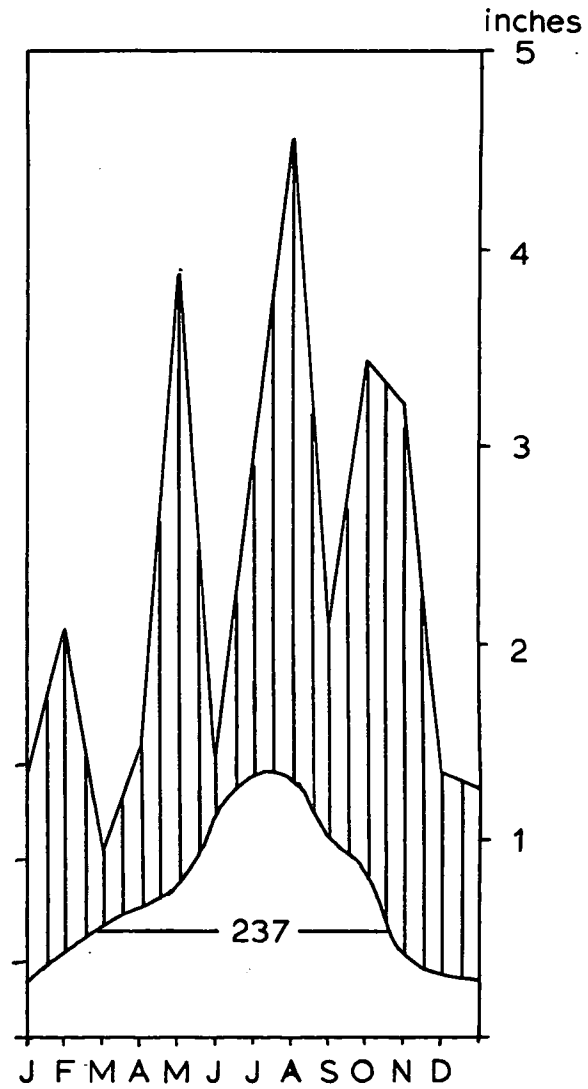
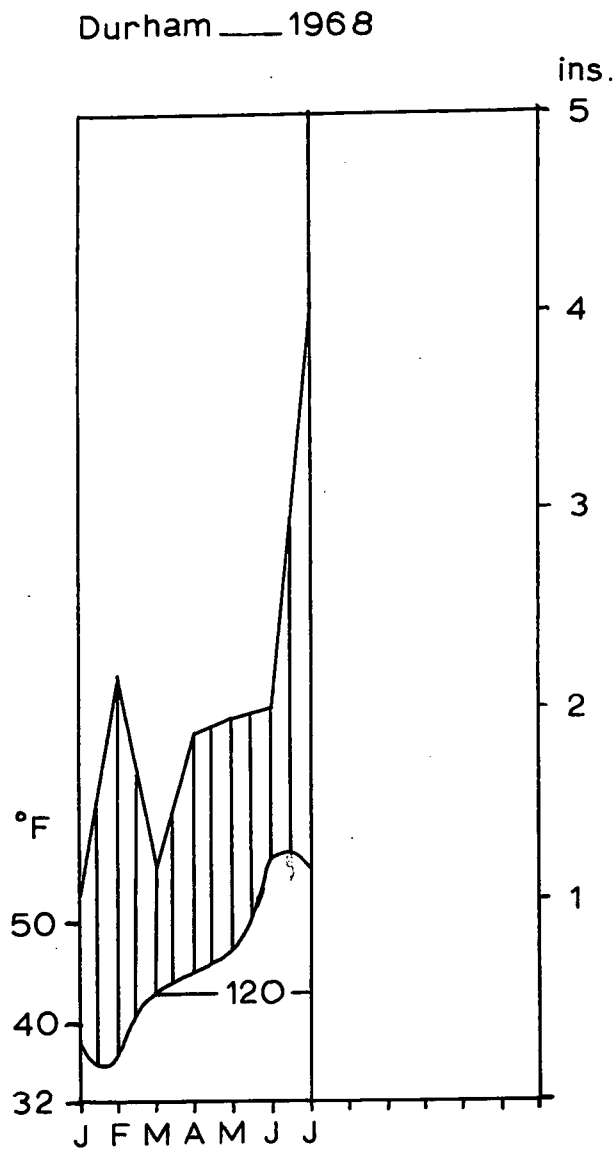
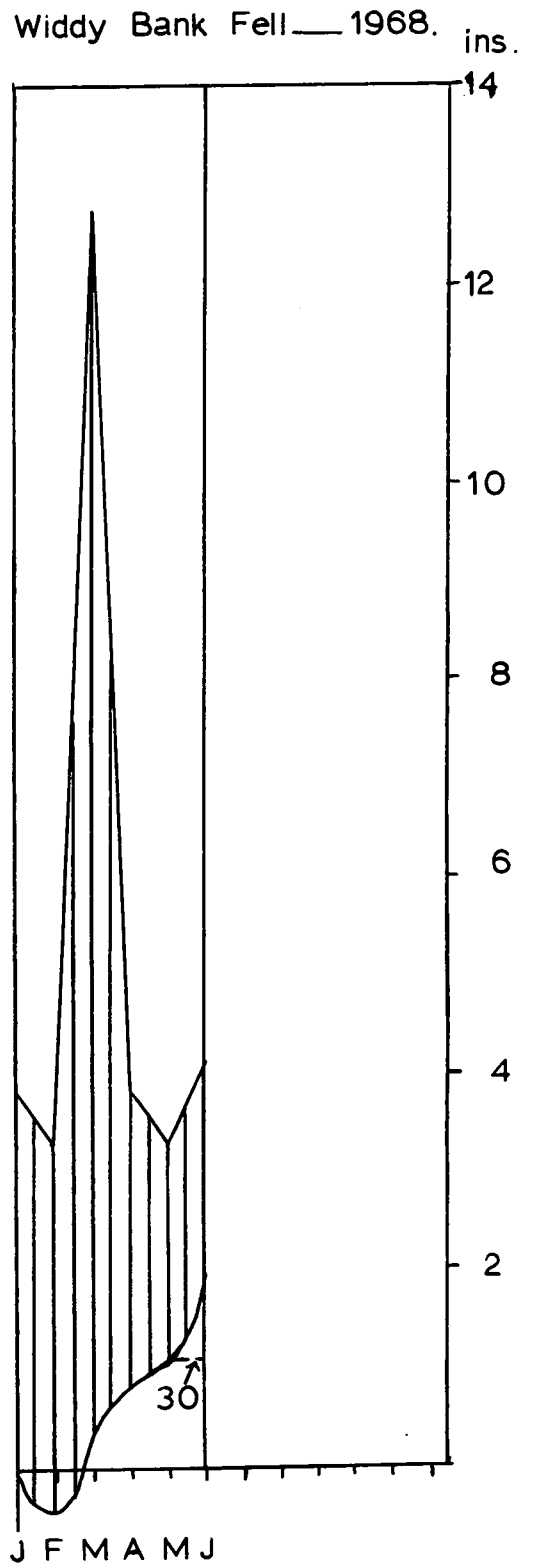

Fig. 7 (a)



(b)



From a very quick phytosociological survey it was found that four other grasses were growing in association with Sesleria. Agrostis canina was the most common, but Anthoxanthum odoratum and Dactylis glomerata also occurred and there were a few plants of Briza media. Other plants present on the site included Leontodon hispidus, Centaurea nigra (ssp. nemoralis?), Campanula rotundifolia, the orchid Gymnadenia conopsea, Pimpinella saxifraga, Plantago lanceolata, Thymus serpyllum agg., Carex flacca, C. caryophyllea, and a species of the genus Petasites. Several of these have been described as plants of calcareous soils.

The Teesdale site was on the sloping valley sides of a small sike which ran down to join the River Tees on its left bank. Sesleria was found on both north and south-facing slopes but was most common on the south-facing side where it grew on the steeper parts and in tufts at the edge of exposed rock surfaces. At best some six inches of dark reddish brown soil had developed but in some places the plants seemed to be growing straight out of the weathered grit of sugar limestone on bare rock with a 'humus sand' skeletal soil. As in Cassop Vale, these sites were well drained and the fact that Sesleria avoided the damper lower slopes and the marshy valley floor (the vegetation of which was dominated by Carex spp.) reinforces the impression of this plant's partiality for dry habitats.

The meteorological station on Widdy Bank Fell had only been operating for seven months so there are no long term data for Upper Teesdale. However, Fig. 7(b) bears out the startling difference in climatic conditions between Upper Teesdale and Cassop Vale. Mean temperatures remained below freezing point for the first two and a half months of the year and did not rise above 42.8<sup>o</sup>F (the theoretical starting point for vegetative growth) until May, and it seems likely that they will fall below this point again before October, giving the plants a very much reduced growing season. While temperatures were low precipitation was very high, with a maximum of 12.7 inches of rain in March and two or three inches more than Durham in other months. The snowfall in winter is considerable and may lie in sheltered places as late as March.

The vegetation of a typical metre quadrat in the Sesleria localities usually included the following species:

<i>Festuca ovina.</i>	<i>Minuartia verna.</i>
<i>Thymus drucei.</i>	<i>Campanula rotundifolia.</i>
<i>Carex caryophyllea.</i>	<i>Tortella tortuosa.</i>
<i>C. capillaris.</i>	<i>Dryas octopetal</i> <del>a</del> .
<i>Koeleria gracilis.</i>	

Festuca ovina in particular grew in tussocks closely mixed with Sesleria while the other species occupied the intervening spaces.

#### Soil analyses

Table III shows the results of the laboratory studies of the four soil samples. Sample number 1 is from Cassop Vale,

Table III. Analysis of Soil Samples

Sample number	% H <sub>2</sub> O	% organic matter	pH	Ca mg./gm.	Mg mg./gm.	Na mg./gm.	K mg./gm.
1	2.375	34.703	7.5	14.4	3.8	0.156	0.212
2	1.580	23.003	7.6	15.6	0.24	0.268	0.084
3	0.312	29.160	7.7	11.4	0.12	0.628	-
4	2.432	7.736	7.7	8.4	0.64	-	0.336

Site location of soil samples

1. Cassop Vale
2. Upper Teesdale
3. Upper Teesdale (skeletal)
4. Upper Teesdale (Rowan Tree Site)

Note: Blanks indicate undetectable quantities.

2 is from the better developed soil in Upper Teesdale, 3 is the skeletal sugar limestone soil of Upper Teesdale and 4 is from the Rowan Tree site. Ignoring sample 4 for the moment it can be seen that the Cassop Vale soil has both the highest water content and the highest percentage of organic matter.

A high water content is in itself partly indicative of a humus-rich soil but is rather more an indication of a high proportion of the clay fraction in the soil particle size distribution.

This is borne out by sample 3 which has the lowest water content but, next to Cassop, the highest organic matter content. However, this organic matter was composed almost entirely of the partly decomposed roots of grass rather than true humus. Sample 4, from the Rowan Tree site, was a very clayey soil. This fact is reflected in the high percentage water content, which was higher than the other three although the percentage of organic matter was distinctly lower. This was a true 'mineral' soil. The reaction of the soil in all cases was slightly alkaline. The difference between the highest figure (pH 7.7 in samples 3 and 4) and the lowest (pH 7.5 in sample 1) is not regarded as significant.

While examining the mineral analyses of these soils it should be pointed out that control extractions were run through the clean glassware of each sample extraction apparatus to determine the quantities of contaminants. The actual analyses presented in the table have been corrected accordingly so the

controls are not shown.

The Teesdale soil (sample 2) shows the highest quantity of exchangeable calcium, though the difference between this (15.6 mg./gm.) and Cassop Vale (14.4 mg./gm.) is not felt to be very significant. The slightly lower figure for sample 3 is probably indicative of the paucity of exchange sites due to the absence of the clay colloids. It is conceivable that the quantity of exchangeable cations in such a soil fluctuates considerable throughout the year as soil moisture conditions vary. The magnesian limestone soil of Cassop Vale shows a significantly greater proportion of exchangeable magnesium than the soils on the carboniferous limestone of Upper Teesdale. The figures for sodium should be regarded with considerable suspicion and no comparative deductions can be made with such small quantities because the possibility of contamination of samples with sodium from the glassware is greater than for the other elements. Rieley (op. cit.) abandoned his sodium analyses altogether for this reason. Potassium seems to be highest in sample 4 and then in sample 1, while there were no detectable quantities in sample 3 and only a very small amount in sample 2, but the differences are very small and may not be significant.

### Plant Studies

#### a) Morphology and anatomy

The most obvious morphological difference between plants of the two populations was one of size. In this respect the

Cassop plants were considerably larger than those of Upper Teesdale. Furthermore, they tended to possess slender, straggling, stoloniferous developments above the ground while the Teesdale plants were interconnected by extensive rhizomes within the compact turf. Even within the two populations there were noticeable differences. In some places the Cassop plants were densely tufted and had a great amount of old, dead leaf and sheath material still attached firmly to the short culm. In other places the plants were more readily divisible into individuals, were taller and straighter. The former seemed to be developed on very thin, dry soil while the latter were on the better developed and moister soils. An analogous bimodal situation occurred in Teesdale between the plants on the better soil and those on the skeletal soil of the sugar limestone outcrops. i/

A thorough study was made of the literature on the anatomy of grasses, and plants from the two populations were studied in the light of the findings of other workers. The feature to which the most attention was paid was the sclerenchyma. Metcalfe (1960), referring to Sesleria caerulea said, "The amount of sclerenchyma varies with habitat, but the pattern of its distribution is a reliable taxonomic character." Duval-Jouve (1875) points out that the sclerenchymatous cell development is a protective reinforcement to the vascular system so, in warm and dry habitats sclerenchyma is well developed while in

moist or shaded habitats it is not so well developed.

9  
Upon this basis one would expect the Cassop plants to have a more marked development of sclerenchyma than those of Teesdale. In point of fact the reverse is the case. In Cassop plants all the sclerenchyma are thinner, that is to say, the cells are larger while the cell walls are thinner than in Teesdale plants. The area of sclerenchyma in the leaf margins and the midrib is considerable smaller. The abaxial epidermal cells are scarcely sclerenchymatous at all, while the Teesdale plants have sclerenchymatous epidermal cells which have noticeable thicker outer than inner walls on both adaxial and abaxial surfaces. The adaxial I-girders to the vascular bundles are composed of cells that are more like the chlorenchymatous cells of the outer bundle sheaths than true sclerenchyma in the Cassop plants. Furthermore, the last two or three vascular bundles towards the leaf margin have much reduced I-girders which are only one cell thick instead of two or three cells and sometimes are missing altogether.

The only feasible explanation of this apparent contradiction in terms is that, although Cassop Vale is warmer and drier than Upper Teesdale, the plants in the former are sheltered from the direct rays of the sun for most of the day while the plants in the latter have to stand up to the dessicating effect of strong, cold winds and the rigours of very low temperatures. Without the protective insulation of thick-walled sclerenchymatous cells

the plants would wither and die under such conditions.

b) Calorific value

Table IV shows the results of estimations of calorific value of plant material by bomb calorimetry. No very definite conclusions can be drawn from these. The calorific value of Sesleria caerulea would seem to lie between 4.9 and 5.0 Calories per gram and, although the difference is small, Cassop Vale plants seem to have a marginally higher value than Teesdale plants. Stems and inflorescences seem to have a lower calorific value than leaves.

c) Productive performance

Fig. 8 shows in graphic form the growth of Sesleria in Cassop Vale and Upper Teesdale. Details of the monthly croppings are given in Tables V and VI. The first crops were taken, as near as could be ascertained, at the beginning of the growing season, which came about two months later in Teesdale than in Cassop Vale. The first crops therefore represent the 'over-wintering' biomass, or the weight of green plants left after the winter die-back and before the start of summer growth.

It will be seen that the mean initial weight of Cassop plants is considerably more than Teesdale plants and although their initial rate of growth is somewhat slower than the latter there is a marked steepening of the graph from June onwards. The Teesdale graph is much more regular and is slightly convex, indicating a steadier growth rate which tends to fall off

Table IV. Calorific values of plant material

<u>Cassop Vale plants</u>	<u>K cals./gm.</u>
leaves	4.935 (S.D. 0.165)
stems	4.547 (S.D. 0.359)
flowers	4.597 (S.D. 0.561)

Teesdale plants

leaves	4.655 (S.D. 0.006)
--------	--------------------

Table V. Cassop Vale Field Crops

Date:	5/3/68	5/4/68	5/5/68	2/6/68	30/6/68	30/7/68
<u>Fresh</u>						
Crop weight	3.5771	4.6233	5.7346	6.1249	8.9312	11.7826
Mean plant weight	0.1192	0.1541	0.1912	0.2042	0.2977	0.3928
S.D.	0.0476	0.0564	0.0693	0.0740	0.0719	0.0959
<u>DIY</u>						
Crop weight	1.1200	1.1887	1.8277	2.0249	2.8704	3.8858
Mean plant weight	0.0373	0.0396	0.0609	0.0675	0.0957	0.1295
S.D.	0.0029	0.0104	0.0235	0.0283	0.0258	0.0433
<u>Water content</u>						
Total per crop	2.4571	3.4346	3.9069	4.0164	6.0588	7.8968
Mean per plant	0.0819	0.1145	0.1302	0.1339	0.2020	0.2632
S.D.	0.0225	0.0375	0.0516	0.0520	0.0475	0.0662
<u>Percentage water</u>						
Mean per plant	68.7	74.3	68.1	67.4	68.0	66.9
S.D.	3.5	3.4	2.2	3.2	2.1	1.8

Table VI. Upper Teesdale Field Crops

Date:	1/5/68	21/5/68	27/6/68	29/7/68
<u>Fresh</u>				
Crop weight	1.1741	2.2440	3.5804	4.4913
Mean plant weight	0.0391	0.0748	0.1193	0.1497
S.D.	0.0172	0.0224	0.0469	0.0338
<u>Dry</u>				
Crop weight	0.3179	0.6547	1.1109	1.6188
Mean plant weight	0.0106	0.0218	0.0370	0.0540
S.D.	0.0057	0.0072	0.0144	0.0119
<u>Water content</u>				
Total per crop	0.8542	1.5893	2.5699	2.8725
Mean per plant	0.0285	0.0530	0.0857	0.0958
S.D.	0.0124	0.0167	0.0337	0.0228
<u>Percentage water</u>				
Mean per plant	72.9	70.9	69.6	64.0
S.D.	3.6	2.1	2.3	2.3

Figure 8

Growth of field plants

(mean weight of 30 plants in successive crops;  
upper line = fresh weights; lower line = dry weights)

Fig. 8

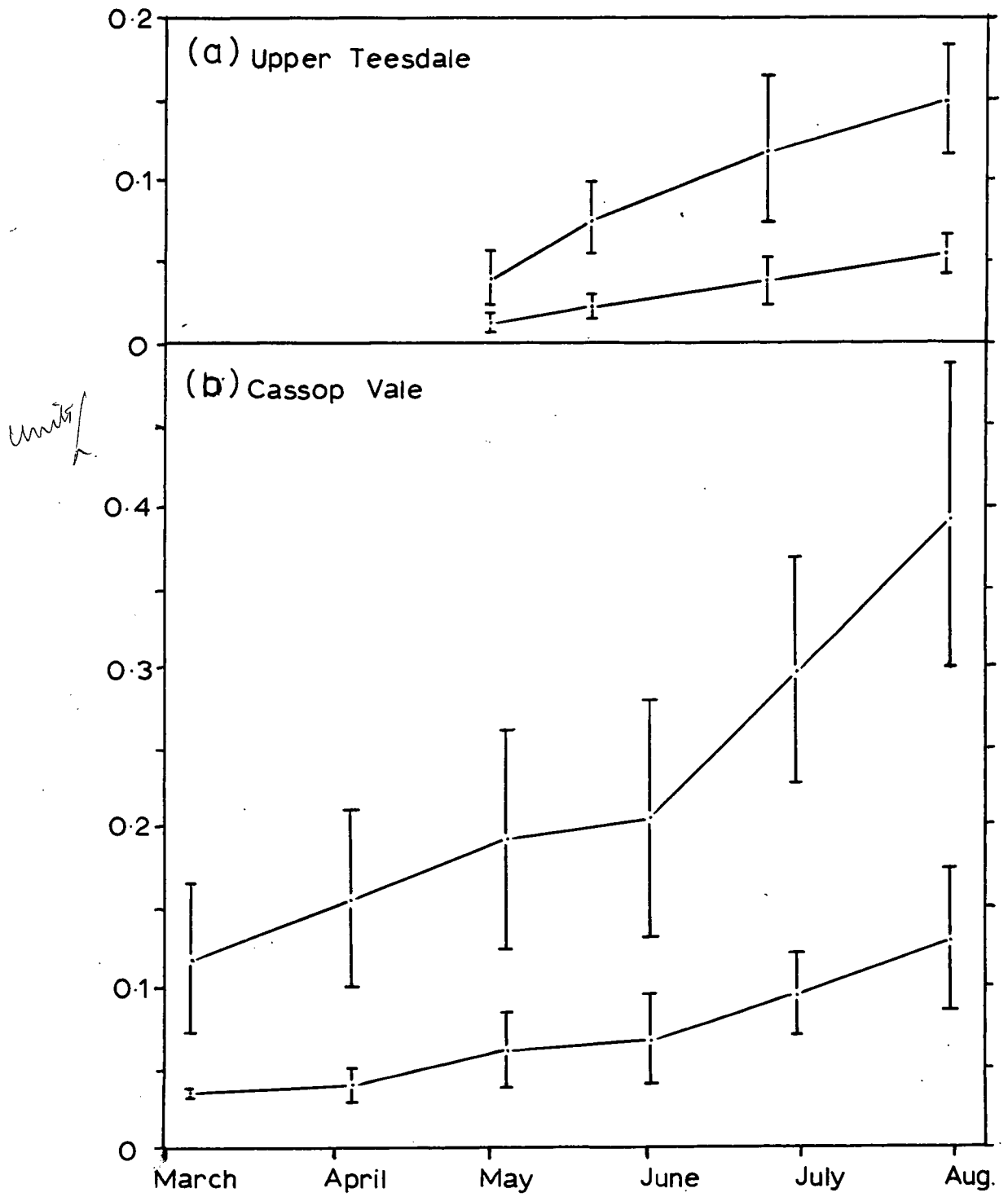

through the season, resulting in a large disparity between the weights of plants of the two populations at the end of July. At the last crop Cassop plants had a mean fresh weight of 0.3928 gms. while Teesdale plants were only 0.1497 gms. The same trend is reflected in the dry weights, though the changes in these are much more compressed as the effects of fluctuating water content are absent. Little difference can be detected in the percentage water content of plants from the two populations.

This marked difference in the performance of the two populations is impressive evidence of the depressive effect of harsh climatic regimes on the growth and productive performance of plants. Everyone is familiar with descriptions of the stunted vegetation of Tundra regions, where many familiar species of Cool Temperate climatic regions grow to a fraction of their normal size. Here, in Upper Teesdale, we have a species of grass growing to a third of the size that it attains under more temperate conditions as a result of the shortened growing season and comparatively low mean temperatures.

d) Mineral analysis

The results of the mineral analyses of the various field crops are given in Tables VII and VIII, expressed in milligrams per gram of dry plant material and in milligrams per plant respectively. These results are plotted in graphic form in Figs. 9-12. It became clear that in many respects these results were similar to those obtained by Rieley (op. cit.) with Carex spp.

Table VII. Analysis of field crops

Cassop Vale

Above ground parts: mg./gm. of dry plant.

Date of crop	Ca	Mg	Na	K
5/3/68	4.03	5.60	1.66	24.96
5/4/68	0.75	3.02	1.43	64.89
5/5/68	2.51	3.76	0.85	65.25
2/6/68	2.64	3.30	0.69	53.40
30/6/68	3.01	2.65	0.46	64.42
30/7/68	3.00	3.00	0.72	72.00

Below ground parts:

5/3/68	11.32	5.66	1.34	8.83
--------	-------	------	------	------

Upper Teesdale

Above ground parts:

1/5/68	4.43	2.87	0.76	73.04
21/5/68	5.54	2.61	1.79	65.15
27/6/68	3.13	2.06	0.54	56.04
29/7/68	4.68	1.56	0.58	49.60

Below ground parts:

1/5/68	4.10	1.47	1.36	13.37
--------	------	------	------	-------

Table VIII. Analysis of Field Crops

Cassop Vale

Above ground parts: mg./plant.

Date of crop	Ca	Mg	Na	K
5/3/68	0.1503	0.2089	0.0619	0.9310
5/4/68	0.0297	0.1196	0.0566	2.5696
5/5/68	0.1529	0.2290	0.0518	3.9737
2/6/68	0.1782	0.2228	0.0466	3.6045
30/6/68	0.2881	0.2536	0.0440	6.1650
30/7/68	0.3885	0.3885	0.0932	9.3240

Below ground parts:

5/3/68	0.4460	0.2230	0.0528	0.3480
--------	--------	--------	--------	--------

Upper Teesdale

Above ground parts:

1/5/68	0.0470	0.0304	0.0081	0.7742
21/5/68	0.1208	0.0569	0.0390	1.4203
27/6/68	0.1158	0.0762	0.0200	2.0735
29/7/68	0.2527	0.0842	0.0313	2.6784

Below ground parts:

1/5/68	0.0533	0.0191	0.0177	0.1738
--------	--------	--------	--------	--------

Figure 9

Mineral analysis of Cassop Vale  
field crops in mg./gm.

Fig. 9

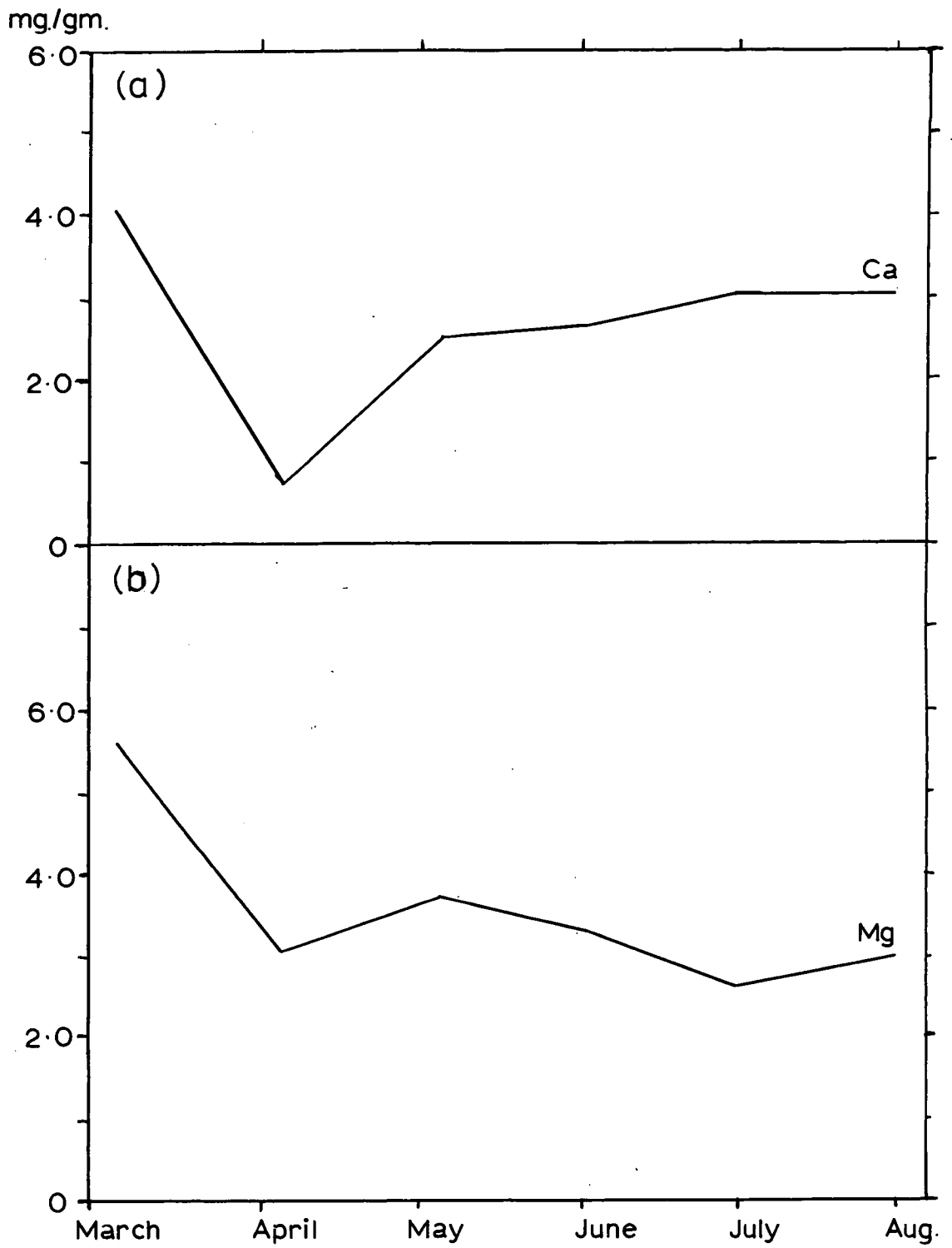

Fig.9 (contd.)

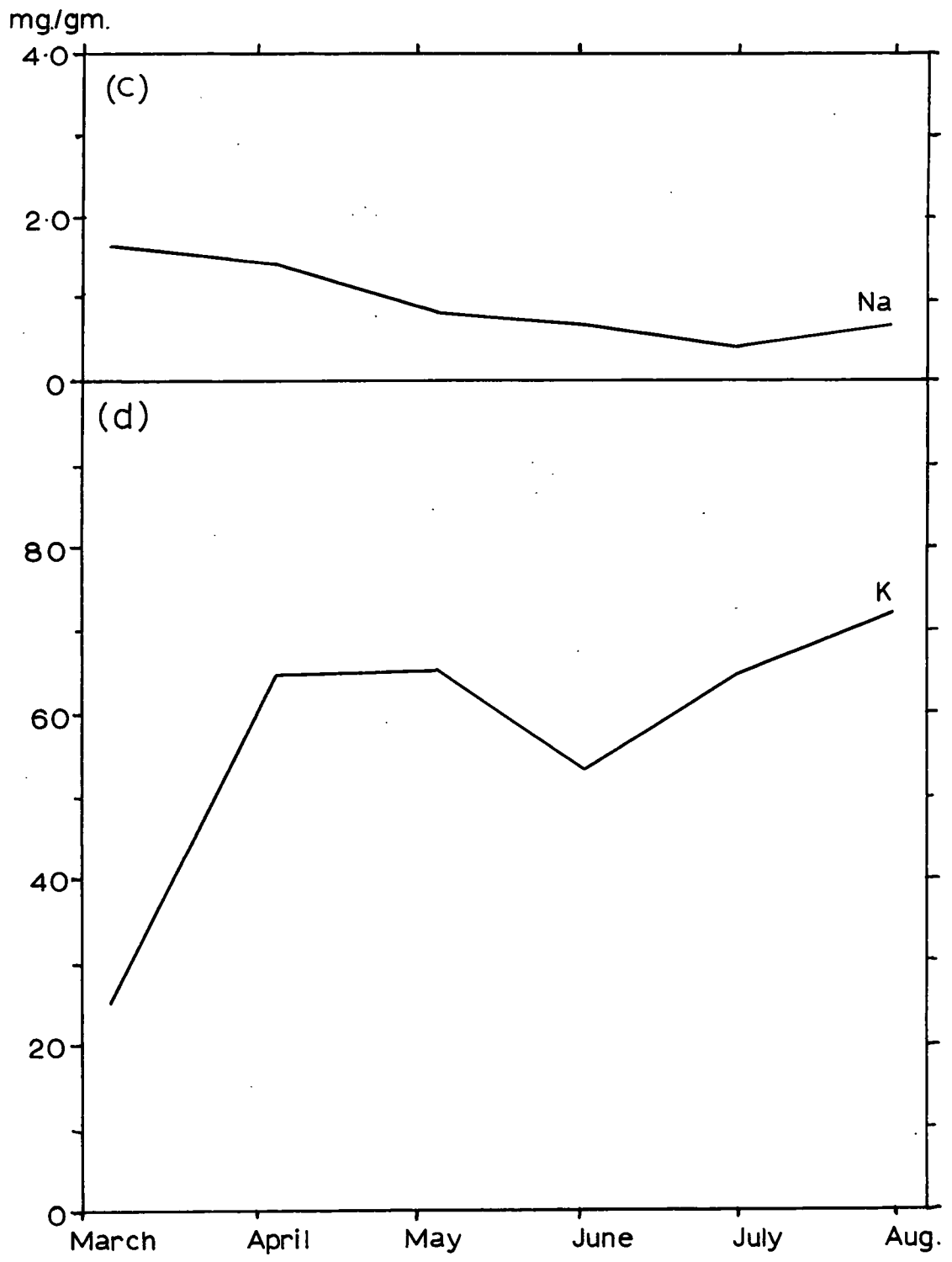

Figure 10

Mineral analysis of Upper Teesdale  
field crops in mg./gm.

Fig.10

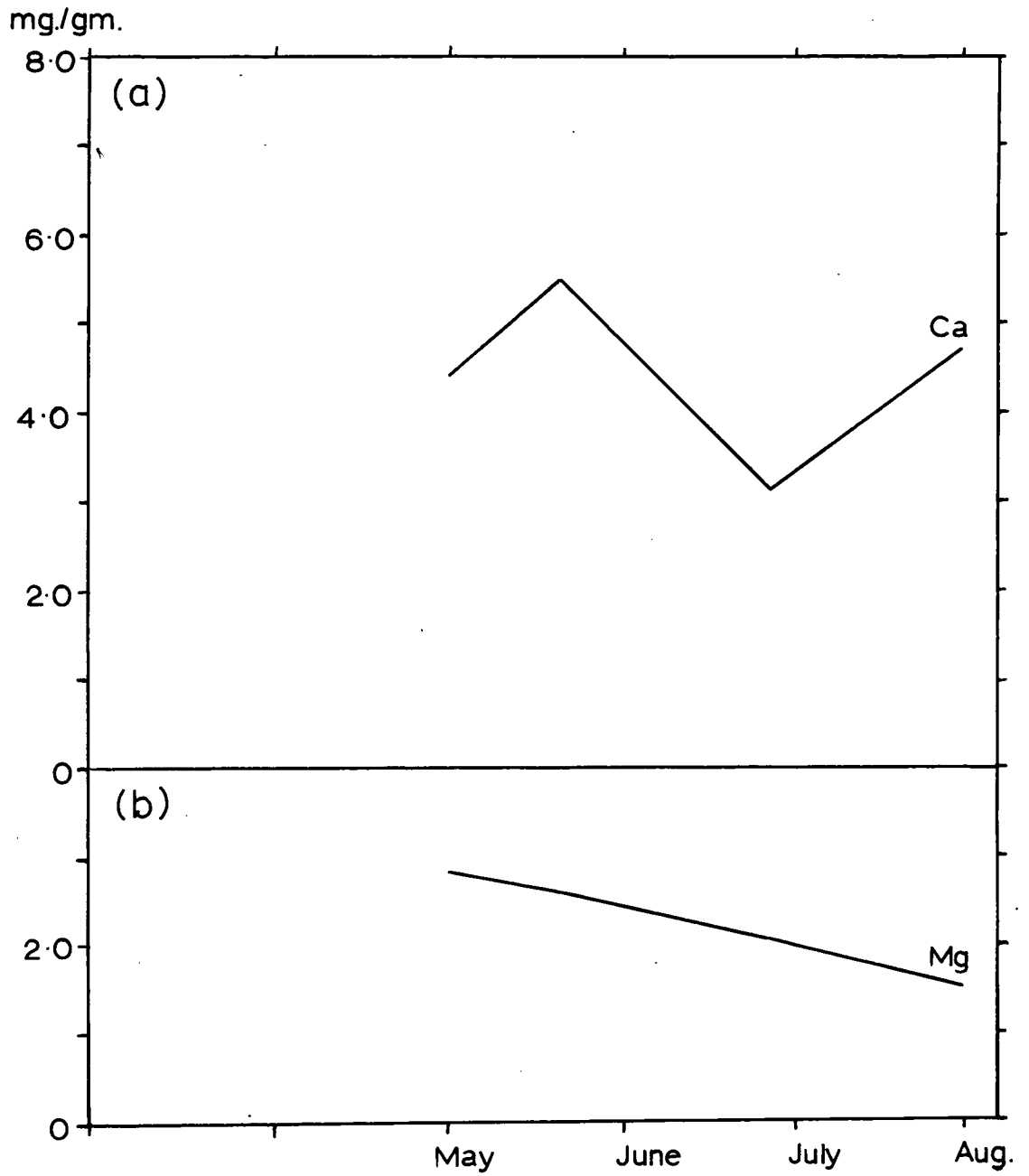

Fig.10 (contd)

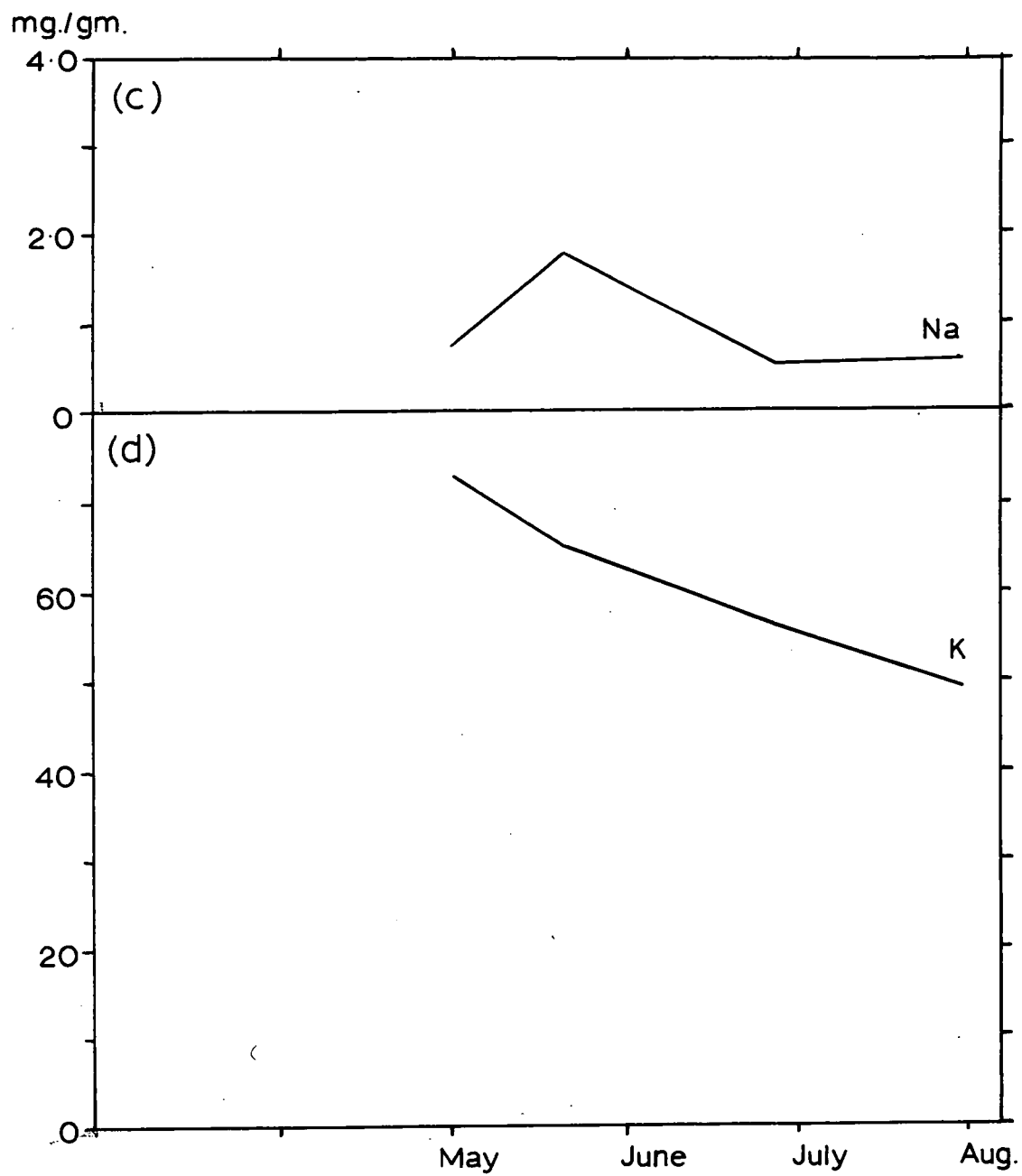

Figure 11

Mineral analysis of Cassop Vale  
field crops in mg./plant

Fig. 11

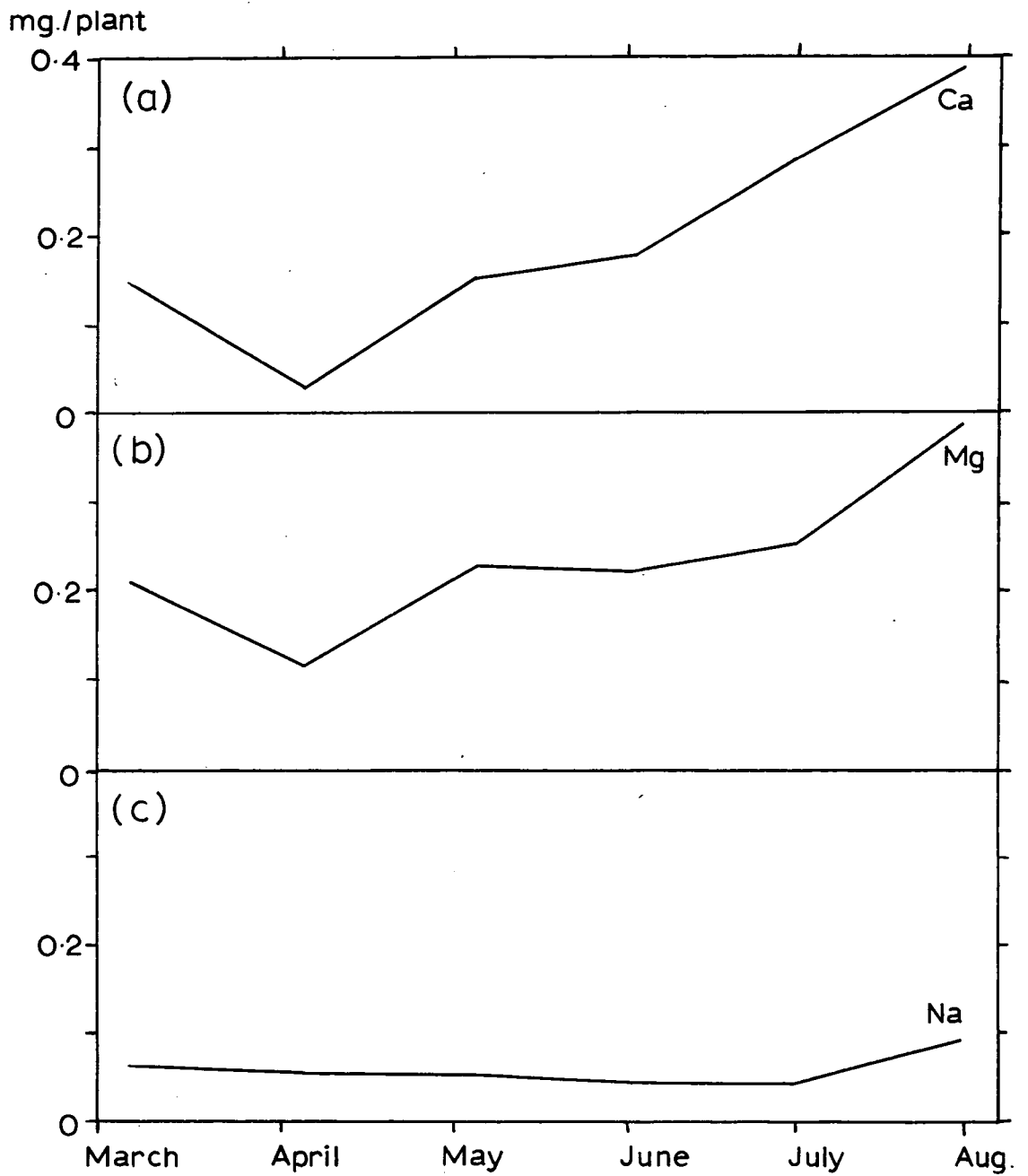

Fig. 11 (contd.)

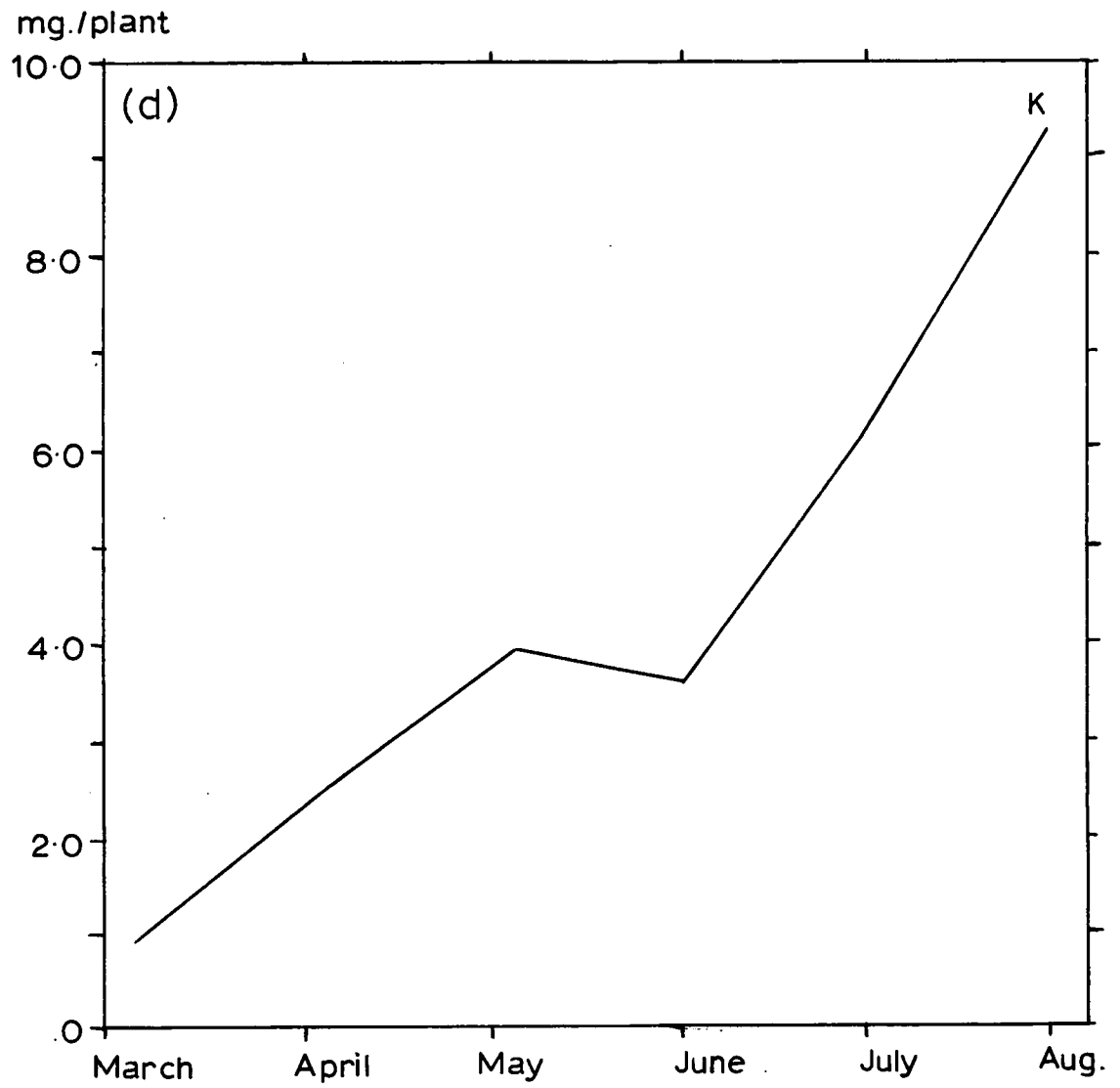
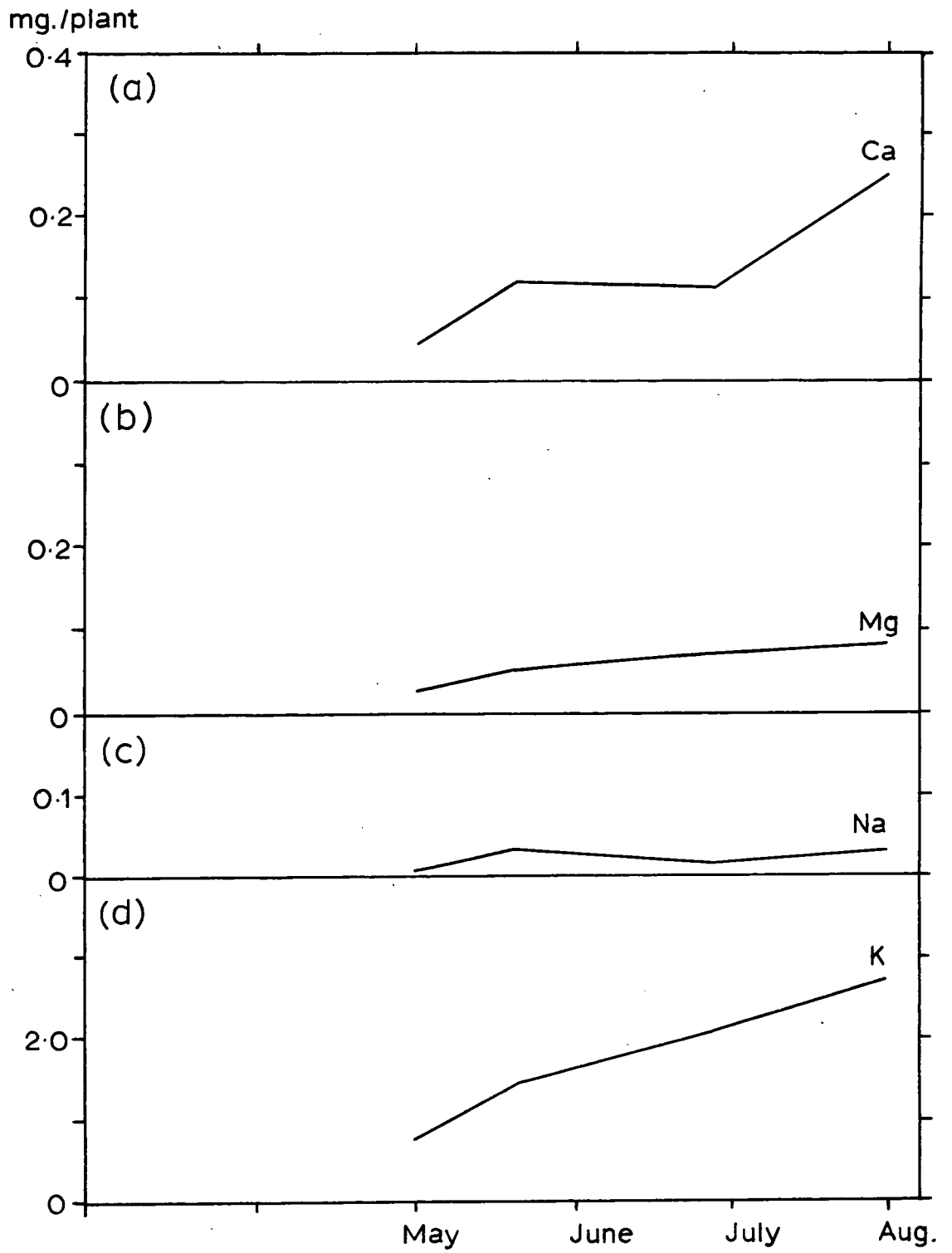

Figure 12

Mineral analysis of Upper Teesdale  
field crops in mg./plant

Fig.12



As pointed out by Collander (1941), the most copiously accumulated cation is potassium, which reached a maximum concentration of 73.04 mg./gm. in the shoots of Teesdale plants. However, this cation seems to be present in much smaller quantities in the roots, although even here it is still proportionately more than the other elements excepting calcium in the first Cassop crop. The potassium absorption is marginally higher in the Teesdale plants than in the others. If we are to accept Collander's view that as a general rule the absorption ratio of a given ion increased as the concentration of that ion in the medium decreases, then this difference can be partly explained by the smaller quantities of K in the Teesdale soil. A further explanation lies in the relatively higher proportion of Ca in the Teesdale soil. Several authors have shown by culture experiments that higher concentrations of this cation in the soil tend to enhance the absorption of potassium (Olsen, 1942; Gauch, 1957).

Rieley found that the percentage of potassium was high in young plants and increased further to a peak in May but thereafter decreased consistently throughout the rest of the year. At the same time, the absolute amount of K per plant was low in developing tillers and the subsequent trend was reversed. In other words young shoots have a high concentration of potassium in a small dry weight. In general his results have been reflected in the present study, but the Cassop plants behaved somewhat

differently in that, although the percentage of potassium increased until May and then began to fall, it increased again from June onwards. However, Rieley also noted that Carex flacca showed a pulse of potassium uptake with each growth pulse. As already noted, the Cassop plants experienced a considerable acceleration of growth rate from the beginning of June and this is matched by a steeper rise of the graph for milligrams of potassium per plant, resulting in an upward trend in the proportional graph. A similar, though less intense reaction is seen in the Teesdale plants in which the increase of potassium per plant is greatest where the growth is most rapid during the first month.

The level of calcium in the plant shows a very similar trend to that of potassium, being comparatively low at the beginning of the year and increasing rapidly during the main period of growth, indicating a rapid absorption for the synthesis of cell walls. The Teesdale plants seem to have had considerably more calcium than the Cassop plants throughout the season, but the trends are very much the same and the fact that the 'slack' period in May, indicated by a flattening of the graph for Cassop, occurs a month later in Teesdale is further evidence for the lateness of the season there. Since calcium is known to be 'fixed' in the plant and incapable of translocation via the phloem the fluctuations in concentration are indicative of the changing proportionality of other elements and of water etc.

In view of this it is hard to understand the initial drop of calcium per plant in the Cassop population. One possible explanation is that the first Cassop crop was taken before the plants had really started to grow and the so-called live plant was composed largely of senescent green leaves which had not yet turned brown but had done so by the time of the next crop.

With regard to magnesium the status of the two populations is reversed and the Cassop plants have a higher average level of this cation. This is confirmed by Rieley's findings and would seem to be in direct contradiction of Collander's rule. In the Cassop population the absolute concentrations of magnesium per plant follow a very similar pattern to that of calcium and it therefore seems reasonable to assume that the same laws govern the absorption of both these cations. This parallelism also serves to confirm Sutcliffe's (1962) opinion that the calcium and magnesium absorption sites are independent of one another.

The pattern of sodium absorption is rather difficult to interpret. The concentrations of this ion are considerably lower than the others and the only point on which the two populations can really be said to agree is in the slight increase of sodium per plant and per gram in July. In terms of milligrams per gram the sodium level in Cassop plants seems to be inversely related to that of potassium to a certain extent but this relationship is not entirely true of the Teesdale plants.

Sutcliffe (ibid.) is of the opinion that high external potassium levels tend to suppress sodium uptake but that the reverse relationship is not so strong. In other words there is a certain amount of competition between the two and potassium has the advantage. Gauch (op. cit.), on the other hand, quotes Joham (1955) as saying that these two ions do not compete for absorption, so he assumes that the reciprocal changes of balance observed by some authors are due to internal control exercised by the plant cells. It is possible that some such mechanism is operating in Sesleria but it would be unwise to be categorical in view of the doubtful accuracy of the sodium analyses.

To summarise these results it is evident that certain trends can be detected in the absorption of these ions which can to some extent be related to the seasonal growth of the plants and to ionic balances within the plants and in the soil.

Some interesting additional results were obtained from analyses of plant material collected from Cassop Vale on the 30th June (Table IX). Green leaves, dead leaves and the dead tips of green leaves were analysed separately and it became obvious that there were considerable differences in the mineral status of these.

Calcium was found to be concentrated at much higher levels in the tips of leaves than anywhere else. This is because calcium moves rapidly up the leaf towards the tips and when this

Table IX. Analysis of field material  
from Cassop Vale,  
collected 30/6/68.

Material	mg./gm. of dry plant.			
	Ca	Mg	Na	K
Green leaves	4.70	3.54	0.44	22.02
Dead leaves	9.80	5.22	0.58	1.58
Dead tips of leaves	13.12	5.44	4.69	7.31

part dies back water and some of the other cations are lost again, leaving calcium at a relatively high concentration per-unit dry weight. Potassium, on the other hand is at its lowest in dead leaves and tips, indicating a rapid re-absorption from dying tissue into the living photosynthetic parts. These results agree very well with those of Rieley (op. cit.) who made separate analyses of the sheath, upper and lower halves of the lamina and the dead tips of Carex spp. He found that calcium increased from a very high level in the dead tips, while potassium was lowest in the dead tips and sheaths and highest in the upper photosynthetic lamina. The differences in magnesium concentration are not so great but this cation, like calcium, tends to be left in the dead parts. Sodium appears to be concentrated in the dead tips to a considerable extent, but again the analyses are suspect.

One fact that emerges clearly from these results is that the results of analyses of whole plants (excluding roots that is) will depend to a considerable extent on the proportion of dead material included.

## Chapter 5. RESULTS OF CULTURE EXPERIMENTS

### Productive performance

Any conclusions that may be drawn about the performance of the culture plants can really only be reached in the light of the nutrient dynamics, but a preliminary survey of the relative productive performance of the plants in various culture treatments can be made at once.

From Fig. 13 and Table X it will be seen that of the Cassop Vale plants those in the high calcium treatment showed the best vegetative production. The high nitrate treatment also did very well but both of these were only marginally better than the control plants. The low calcium and magnesium treatments (from which these elements respectively were completely omitted) had a distinctly suppressive effect on the performance of the plant and yet the high magnesium treatment did little better.

The performance of plants in the low nitrate treatment was seriously suppressed, the mean production being only just over half that in the high treatment. The high phosphate treatment did better than the low treatment but still did not do as well as the control plants. The absence of zinc in the low zinc treatment obviously affected the plants very considerably as these plants did less well than any of the others. The high level of zinc in the other half of this treatment pair apparently had a somewhat toxic effect as the plants did not do as well as

Table X. Cassop Vale Culture Plants - Production

Treatment	Total weight	Mean weight	S.D.	No. of Plants
+ Ca	12.5778	0.7861 0.4031	0.4781	16
- Ca	11.0171	0.5798 0.2973	0.2012	19
+ Mg	7.6105	0.5436 0.2788	0.1950	14
- Mg	3.0854	0.4408 0.2261	0.1480	7
control	9.7053	0.7466 0.3829	0.3389	13
+ NO <sub>3</sub>	5.4723	0.7818 0.4009	0.2941	7
- NO <sub>3</sub>	1.8391	0.4598 0.2358	0.1721	4
+ PO <sub>4</sub>	5.3560	0.5951 0.3052	0.1833	9
- PO <sub>4</sub>	9.4891	0.4745 0.2433	0.1351	20
+ Pb	7.4896	0.4993 0.2561	0.1520	15
- Pb	5.7061	0.3003 0.1540	0.0974	19
+ Zn	7.3410	0.5244 0.2689	0.1949	14
- Zn	8.8264	0.7790 0.3482	0.2313	13

Date of planting: 5/3/68

Date of completion: 1/7/68

Time in culture: 117 days

Lower mean weight figures represent estimated production over 60 days.

Figure 13

Cassop Vale Culture Plants - Production

Columns represent mean plant growth in each culture.

Diagonal shading	=	high treatment
Unshaded	=	low treatment
Horizontal shading	=	control culture

Fig.13

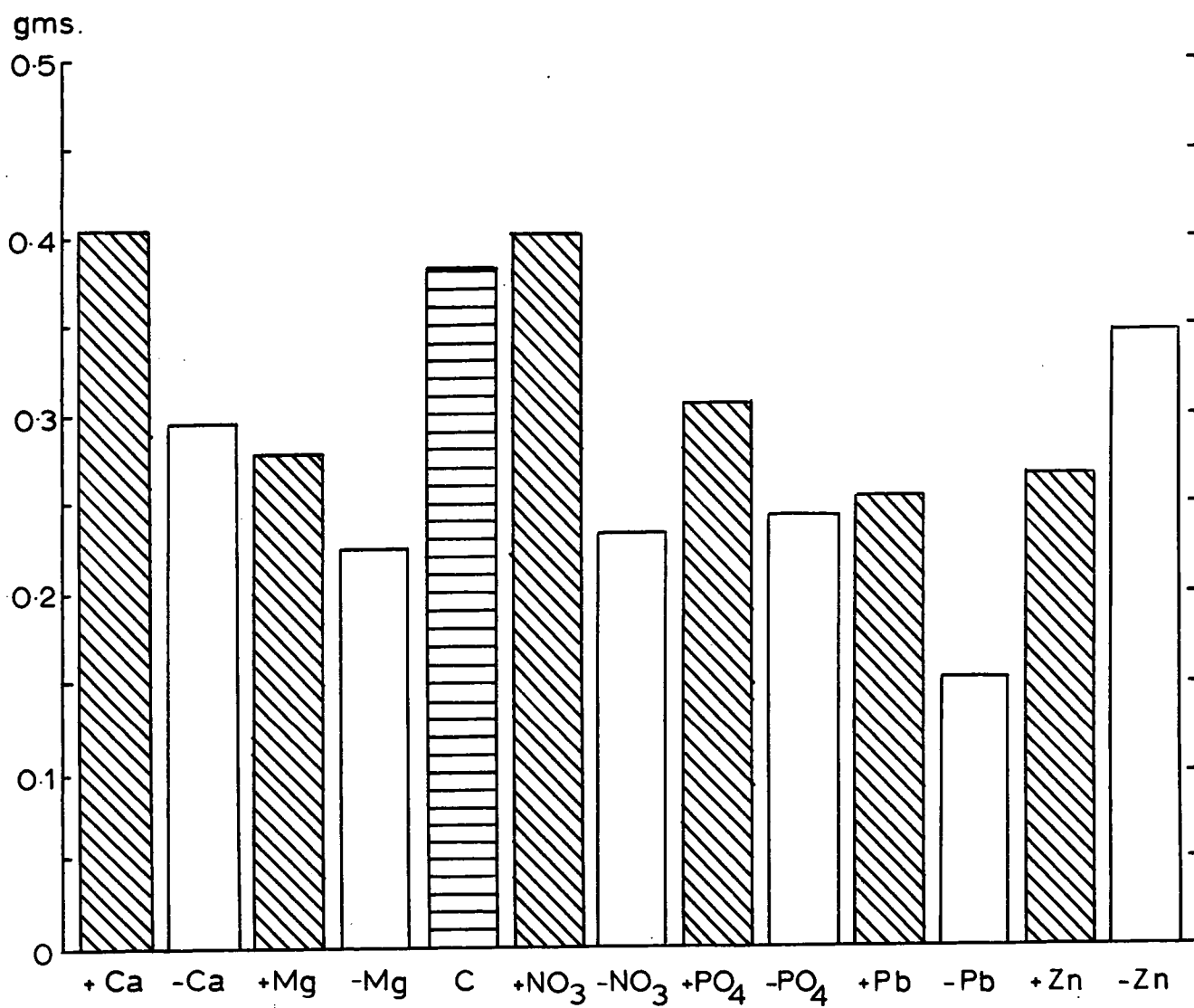

Table XI. Upper Teesdale Culture Plants - Production

Treatment	Total weight	Mean weight	S.D.	No. of plants
+ Ca	6.5729	0.2120	0.0758	31
- Ca	7.9944	0.2284	0.1060	35
+ Mg	7.7459	0.2421	0.1030	32
- Mg	7.6007	0.2923	0.2011	26
control	12.6342	0.4076	0.1520	31
+ Pb	7.5777	0.2148	0.1248	35
		0.3682		
- Pb	7.8096	0.2169	0.0684	36
		0.3718		
+ Zn	8.6271	0.2465	0.1040	35
		0.4226		
- Zn	8.3079	0.2374	0.0786	35
		0.4070		

+ Ca — control: Date of planting: 1/5/68  
 Date of completion: 1/7/68  
 Time in culture: 60 days

+ Pb — - Zn: Date of planting: 25/5/68  
 Date of completion: 1/7/68  
 Time in culture: 35 days

Lower mean weight figures represent estimated production over 60 days.

Fig.14

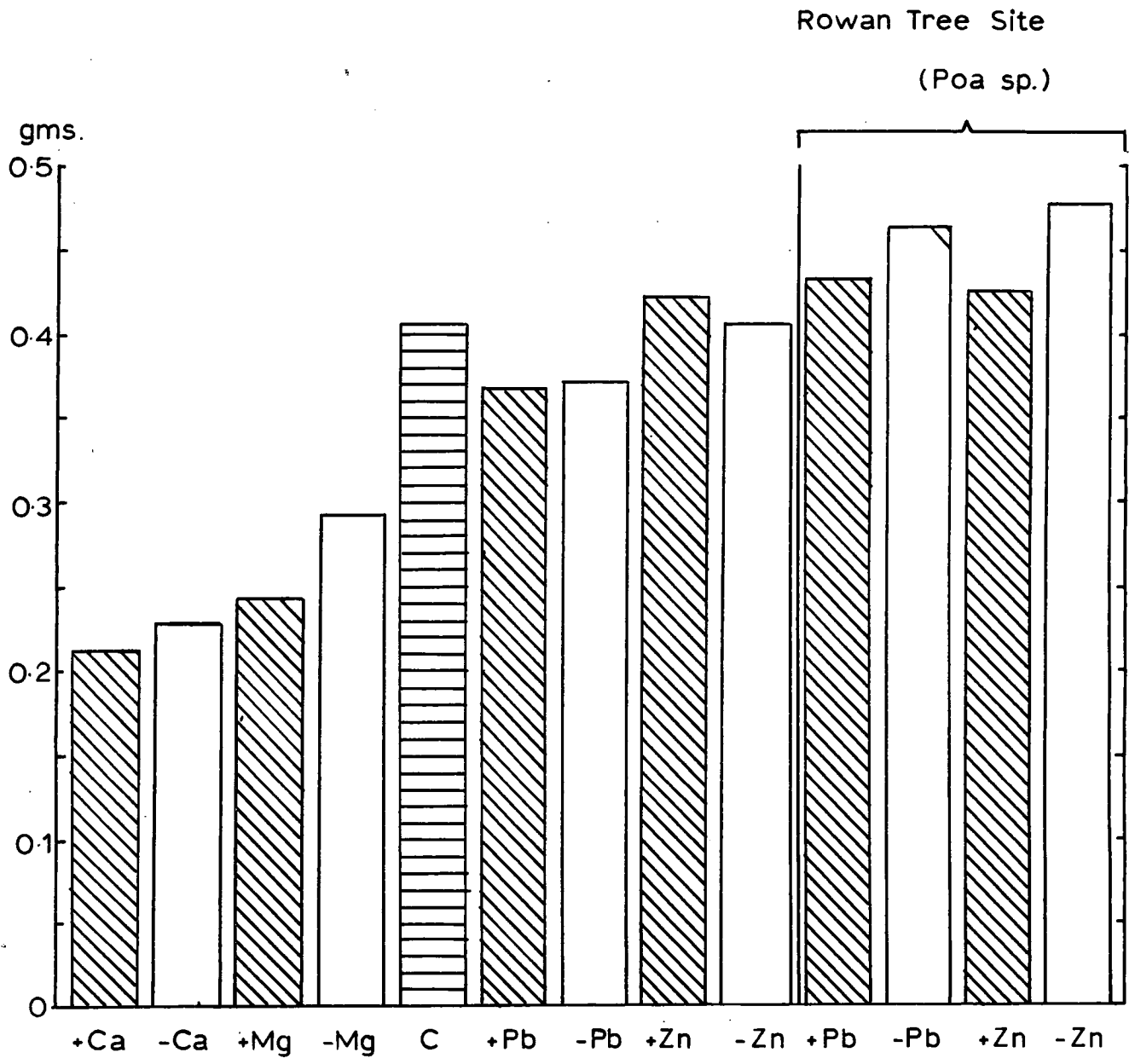

the controls, though a toxic level of zinc seems to have been less harmful than a deficiency in this case. The presence of small amounts of lead does not seem to have seriously affected vegetative growth but higher levels appear to be toxic to these plants and to hinder their growth.

Turning to the Teesdale plants, those in the high zinc treatment did amazingly well, slightly better than the controls in fact, though the difference is not significant. At the same time, the plant would not appear to have been troubled by the absence of zinc from the culture medium as the low zinc treatment plants grew just as well as the control plants. Lead seems to have a slightly suppressive effect but there was no difference to speak of between the high and low levels so one is inclined to assume that any effect was insignificant.

Both the calcium and magnesium treatments shewed very poor growth; the high calcium treatment poorest of all. This could indicate an intolerance of very high calcium levels and a similar intolerance of high magnesium levels.

With respect to magnesium, plants of the two populations show a somewhat similar response except that Teesdale plants seem to be more tolerant of a deficiency and slightly less tolerant of high levels. The big difference lies in their response to calcium, which in the case of Teesdale plants is very large in a negative sense. Teesdale plants seem to have been affected very little by the lead and zinc treatments whereas

Cassop plants shewed a distinct negative response.

It is not really possible to draw any conclusions about the Poa plants from the Rowan Tree site as there were no controls or standards of comparison. All that can be said is that the plants, which started off as very tiny specimens indeed, grew at a tremendous rate and ended up as tall, healthy plants looking much better, in fact, than most of the other culture plants. They seem to have done slightly better in the low than the high treatments. As these plants are from a lead mine spoil heap one would like to be able to conclude that this performance in culture was proof that they possessed a tolerance to heavy metal toxicity. As it is one dare not do so in the absence of controls and in view of the taxonomic discrepancy.

A further point of difference between the two populations of Sesleria in the culture experiments is in the percentage water content calculated from fresh and dry weights. A comparison of Tables XIII and XIV shows that the Cassop plants had a higher water content per unit dry matter than those of Upper Teesdale. This is almost certainly a reflection of their differing cellular structure (see previous chapter). The Teesdale plants had much thicker cell walls and the intra-cell spaces were proportionately smaller.

Table XIII. Cassop Vale Culture Plants - water content.

Treatment	Shoots %		Roots %		No. of plants
	Mean H <sub>2</sub> O	S.D.	Mean H <sub>2</sub> O	S.D.	
+ Ca	67.0	2.8	72.3	7.3	16
- Ca	63.8	3.8	69.8	5.3	19
+ Mg	62.3	5.4	66.2	6.1	14
- Mg	58.4	6.1	67.2	4.7	7
control	66.1	2.9	71.7	6.2	13
+ NO <sub>3</sub>	67.0	4.6	74.9	4.9	7
- NO <sub>3</sub>	61.9	6.1	70.1	4.0	4
+ PO <sub>4</sub>	67.8	4.5	72.2	4.3	9
- PO <sub>4</sub>	62.7	4.6	66.5	5.4	20
+ Pb	61.8	7.3	64.4	6.1	15
- Pb	62.9	3.0	62.9	3.9	19
+ Zn	64.7	8.1	70.2	4.0	14
- Zn	61.5	8.6	71.0	5.2	13

Table XIV. Upper Teesdale Culture Plants - water content

whole plants %

Treatment	Mean H <sub>2</sub> O	S.D.	No. of plants
+ Ca	57.5	6.7	31
- Ca	55.7	6.0	35
+ Mg	59.7	4.8	32
- Mg	59.0	6.1	26
control	58.7	5.6	31
+ Pb	56.4	4.3	35
- Pb	52.3	10.1	36
+ Zn	55.7	4.5	35
- Zn	53.8	4.1	35

Upper Teesdale Rowan Tree site (Poa sp.)

+ Pb	65.0	12.7	35
- Pb	69.3	6.4	35
+ Zn	68.9	12.3	36
- Zn	67.6	7.1	36

One point that should be discussed before going any further concerns the effect that the culture technique itself had upon the survival and performance of the plants. Anatomical studies were made of plants after growing in culture to note any changes in cellular structure. Particular attention was paid to the bulliforme cells in view of Douval-Jouve's (1875) comments on the importance of these cells in their function of opening and closing the leaf. It was thought that the shape of these cells might reflect the difference between climatic conditions in the field and in the greenhouse. The bulliforme cells of the culture plants were somewhat larger and more elliptical in shape than those of field plants. This may mean a greater ability on the part of the leaves to open out flat in the moist conditions of the green house. Another notable change occurred in the outer sheaths of the vascular bundles. These were much more interrupted than in the field plants. The outer sheath of the large vascular bundles was often reduced to three or four cells on one or both sides. The outer sheaths of small vascular bundles, characteristically entire in Sesleria, were often interrupted adaxially and/or abaxially.

Much was said in chapter 3 to make it clear that the experimental conditions and methods were far from ideal and must needs have a more or less serious effect on the plants. It was impossible to assess exactly what this effect was but it can be taken that the high initial mortality (89% in the case of the low nitrate treatment)

among the Cassop plants was due in part to the mistake of trimming the leaves to a standard length but more to the excessive depth of the culture solution in the bowls during the first few weeks. There were considerable differences in the mortality of plants in the various culture solutions and although the solutions themselves must have played some part in affecting the health of the plants there seems to be little direct relationship between percentage mortality and the type of culture treatment.

By the time the Teesdale cultures were set up the techniques had been considerably improved, with the result that the maximum mortality was 28% (in the low magnesium treatment). Again, in considering the nutrient dynamics, the possible loss of calcium as an insoluble precipitate, resulting from the addition of sodium hydroxide to control pH, should be remembered. In spite of the improvements it is felt that the culture medium was insufficiently aerated and there may well have been some suppression of root development and ionic absorption.

#### Nutrient dynamics - analyses

Since there were so many errors inherent in the culturing and analytical techniques it would be dangerous to be too dogmatic about the nutrient dynamics. Nevertheless, even if little weight is given to absolute figures, certain trends are noticeable. For the present purpose attention is confined to the above ground parts of the plants.

Table XV. Analysis of culture plantsCassop Vale

Above ground parts: mg./gm. of dry plant.

Treatment	Ca	Mg	Na	K
+ Ca	1.32	3.20	2.84	25.60
- Ca	1.04	4.00	4.16	19.52
+ Mg	1.04	6.80	3.04	17.60
* - Mg	1.76	2.40	3.44	12.56
control	0.80	3.60	2.52	22.00
+ NO <sub>3</sub>	1.14	4.48	4.48	18.52
* - NO <sub>3</sub>	1.08	3.79	3.56	14.72
+ PO <sub>4</sub>	-	3.18	8.80	15.40
- PO <sub>4</sub>	6.86	4.24	0.96	23.72
+ Pb	1.12	4.36	4.04	23.56
- Pb	4.48	4.89	2.84	18.52
+ Zn	1.92	4.48	3.12	20.96
- Zn	1.32	4.60	3.48	26.00

Below ground parts:

+ Ca	3.60	2.80	3.04	6.88
- Ca	2.80	2.08	3.28	4.48
control	2.00	2.00	3.04	4.48
- PO <sub>4</sub>	3.75	2.77	1.80	4.34
+ Pb	1.46	2.45	3.08	3.68
- Pb	6.63	4.55	2.56	3.24
+ Zn	2.02	1.75	1.92	3.24
- Zn	1.84	3.52	2.48	3.92

Analyses marked with an asterisk include above and below ground parts as there was insufficient material for separate analysis.

Table XVI. Analysis of Culture plantsUpper Teesdale

Above ground parts: mg./gm. of dry plant.

Treatment	Ca	Mg	Na	K
+ Ca	6.08	2.61	1.96	18.67
- Ca	2.82	3.22	2.05	17.74
+ Mg	0.83	5.03	2.87	20.91
- Mg	3.79	2.02	1.81	19.43
control	2.26	2.46	2.74	24.75
+ Pb	5.02	3.57	1.40	20.04
- Pb	8.75	3.70	1.75	17.30
+ Zn	4.37	2.78	1.46	18.04
- Zn	5.66	2.83	1.78	17.36

Below ground parts;

+ Ca	12.75	3.51	3.60	10.04
- Ca	0.93	2.80	3.32	9.82
+ Mg	0.39	2.79	4.19	14.08
- Mg	0.80	1.60	3.92	8.41
control	0.62	1.42	3.09	9.40
+ Pb	1.04	1.73	1.66	9.41
- Pb	3.09	2.16	1.61	8.10
+ Zn	1.32	2.64	2.84	10.35
- Zn	1.42	2.71	2.40	9.06

Table XVII. Analysis of Culture plants  
Upper Teesdale,  
Rowan Tree Site (Poa sp.)

Above ground parts: mg./gm. of dry plant.

Treatment	Ca	Mg	Na	K
+ Pb	3.81	3.29	2.36	26.55
- Pb	2.89	3.02	2.80	27.33
+ Zn	2.55	1.87	3.20	30.70
- Zn	3.35	3.04	3.59	27.94

Below ground parts:

+ Pb	0.53	3.44	4.77	25.26
- Pb	0.62	5.32	2.24	18.99
+ Zn	0.59	2.86	5.14	32.93
- Zn	0.57	3.63	4.94	32.76

In the calcium treatment rather more magnesium was absorbed in the absence of calcium than in the controls and rather less in high calcium conditions of Cassop Vale plants. There is not a large difference in calcium absorption. A similar relationship pertains to the Teesdale plants though here the levels of calcium are higher throughout the treatments while the levels of the other ions are lower. There is a particularly high level of plant calcium in the +Ca treatment. In both cases a high level of calcium has increased the absorption of potassium and suppressed that of sodium.

In high magnesium concentrations the absorption of this ion is noticeably enhanced while calcium absorption tends to be less than in an absence of magnesium. Potassium absorption seems to be greater under high than low magnesium conditions but in both cases less than the controls. Sodium is scarcely affected.

The omission of nitrate from the culture medium suppresses the absorption of the cations while high levels of this important metabolic agent give rise to a more even balance of other nutrients in the plant. The results of the phosphate treatments are rather harder to understand. As phosphate is a metabolically important constituent one would expect an increased absorption of all elements at high phosphate levels. However, no detectable traces of calcium were found in the plants, (though this may well be the result of an analytical error) and magnesium and potassium were both suppressed. Sodium, on the other hand, was present in the

considerable quantities. This is almost certainly because there was much more present in the solution and its absorption was stimulated by phosphate. The low readings for calcium, magnesium and potassium, but particularly the former, are probably the result of interference by  $PO_4$  in the spectrophotometric analysis. For the same reasons calcium showed very high levels in plants of the  $-PO_4$  treatment while sodium was very low.

Little is known about the effects of lead and zinc on the absorption of other ions so it is difficult to make any meaningful interpretation of the results of these experiments. The presence of lead seems to enhance the uptake of calcium to a varying extent and both lead and zinc have had some effect on potassium absorption. The results of the magnesium and sodium analyses tell us very little. The plants of Poa sp. from the Rowan Tree site show little response to variations in lead and zinc levels, having a healthy balance of Ca, Mg, Na and K throughout, except in the case of the  $+Zn$  treatment which seems to have suppressed magnesium absorption.

## Chapter 6. DISCUSSION

The results in chapter 5 show that the plants grown in a variety of culture solutions contain varying quantities and proportions of four cations, namely calcium, magnesium, sodium and potassium. The differential absorption of these cations must be explained by the external concentrations of salts in the culture solutions and interference between ions, a process demonstrated by many workers.

Sutcliffe (1962) indicated that calcium and magnesium absorption sites in plant roots are apparently independent of each other. If this is so there is unlikely to be any mutual interference between these two. However, from the results of the present work the indications are that to some extent calcium and magnesium are reciprocally related in absorption. A possible theory is that the distribution and relative abundance of calcium and magnesium absorption sites varies between plants of different populations depending on the relative abundance of these two elements in the soil. Thus, in the present case, the Cassop plants, from a soil with a comparatively high magnesium content, have rather more magnesium than calcium binding sites, with the result that the former is more readily absorbed when available. This is borne out by the control cultures of the two populations.

Even when the external concentration of calcium is very high magnesium is still more copiously accumulated. When magnesium is not available more calcium is absorbed than otherwise. In the

Teesdale population, on the other hand, magnesium is only absorbed in greater quantities than calcium when the latter is not available or when magnesium levels in the solution are very high. (This case rather suggests that external concentrations of Mg do in fact influence Ca absorption to some extent.) When magnesium is absent rather more calcium is absorbed to compensate but when external concentrations of calcium are very high the absorption of this cation is also very much increased and magnesium reduced.

To put it another way, it might be said that Cassop plants have a greater ability to exclude calcium whereas Teesdale plants absorb it in considerable quantities when available. Olsen (1942) says that the rapid death of seedlings of calcifuge plants grown in calcareous soils cannot be accounted for by mere iron chlorosis but must be the result of a rapid uptake of calcium which blocked the enzyme systems. Unless calcium is transported rapidly to inactive centres it may do this. Olsen went on to say that calcicoly was not so much a need for large quantities of calcium to help growth as an ability to suppress calcium absorption, i.e. a low affinity for calcium. However, the evidence presented here shows that the Teesdale plants do in fact increase their absorption of calcium from high external concentrations and it is therefore suggested that they cope with this by a greater ability to rapidly transport this calcium to inactive centres. In some senses these plants do need more calcium to build up their heavier cell structure.

Various opinions have been expressed on the relationship between calcium and potassium and the effect of one on the absorption of the other. Fawzy et. al. (1954) shewed that low concentrations of calcium in a culture solution stimulated potassium absorption by barley roots in pH's between 2 and 6. Overstreet et. al. (1952) said that calcium could increase or decrease potassium absorption depending on the concentration of potassium in the solution. Nielsen and Overstreet (1955) shewed that calcium enhances potassium absorption and postulated that calcium functioned as a co-factor in the utilization of the potassium carrier. Gauch (1957) concluded that increasing the external concentration of calcium increased the absorption of potassium. Olsen (loc. cit.) shewed that increased calcium increased the absorption of potassium. Olsen (loc. cit.) shewed that increased calcium concentrations diminished the amount of potassium in the leaves of certain calcifuge species while it increased the amount in leaves of Tussilago farfara (a calcicole). Sutcliffe (op. cit.) concludes that calcium suppresses or enhances potassium absorption depending on the concentration of calcium, so that if they compete for absorption sites inhibition will occur when the Ca/K ration is high.

In the Cassop plants potassium absorption is definitely enhanced by high calcium levels and suppressed somewhat by an absence of calcium, but in the Teesdale plants potassium is lower than in the controls in both calcium treatments. Potassium is low

in plants of the  $-NO_3$  treatment because the absence of an important metabolite such as  $NO_3$  halts the uptake of other ions. The fact that it is not also low in the  $-PO_4$  plants may be due to a tendency towards increased alkalinity in this treatment; potassium absorption is enhanced by higher pH values. Potassium is unexpectedly low in the  $+NO_3$  and  $+PO_4$  treatments. This may be due to an indeterminate effect of the increased sodium ion concentration in both these culture solutions. Haas and Brusca (1956) found that with constant external levels of potassium an increase in the external level of sodium raised the level of potassium in leaves, stems and roots of citrus fruit trees. The indications are that in Sesleria sodium has a suppressive effect on potassium uptake. A similar effect was demonstrated by Snaydon and Bradshaw (1961) in Festuca ovina, but as shewn by Joham (op. cit.) this may have been the result of internal adjustment by the plant cells rather than direct competition for absorption.

Some workers have shewn that another effect of high sodium levels is to inhibit the absorption of calcium (e.g. Snaydon and Bradshaw, op. cit.). This might explain the absence of calcium from plants in the  $+PO_4$  treatment. This interference by sodium has upset this experiment and the plants have not responded to additional quantities of  $PO_4$  as well as they might have done. This serves as a warning of the complications introduced by using di-sodium hydrogen phosphate as a source of phosphate. Sodium in

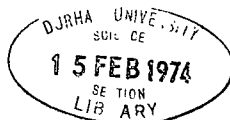

the plants is very low indeed in the  $-PO_4$  treatment because not only was phosphate missing from this treatment but also sodium. The reduction of nitrate absorption in the absence of phosphate (Sutcliffe, op. cit.) is a further hindrance to plant growth.

The occurrence of Sesleria on non calcareous soils such as those developed on mica-schists in other parts of the British Isles and on serpentine soils in Czechoslovakia is a further puzzle. The culture studies of the Cassop Vale plants shed some light on the relationship of Sesleria with magnesium and suggest that this population is a kind of half way situation between populations of calcareous, limestone soils and those of non-calcareous and serpentine soils.

Kruckeberg (1951) has shown that serpentine soils of the United States of America have a high content of magnesium, chromium and nickel and a low content of calcium, nitrogen and phosphate and sometimes molybdenum. He found that the species Streptanthus glandulosus was usually restricted to serpentine soils but was also found on non-serpentine soils. Reciprocal tests shewed that plants from non-serpentine soils did very badly in serpentine soils while the serpentine plants grew well. He postulated the existence of edaphic ecotypes of this plant and hinted that a process of biotype depletion would lead eventually to a pure serpentine strain of S. glandulosus and the elimination of non-serpentine varieties.

He took this study further (1954) and shewed that serpentine plants were adapted to very low calcium levels and were intolerant of the competition in non-serpentine areas. This gave rise to population differentiation and endemism. Walker et. al. (1955) also found that serpentine plants were tolerant of low calcium levels because of their much greater efficiency in absorbing the characteristically low amounts of this ion in serpentine soils. They also absorbed less magnesium than other plants. This question is discussed in connection with the results of the culture experiments in the preceding section.

Zlatnik (op. cit.), in comparing his calcareous and serpentine populations of Sesleria, noted that plants of calcareous soils had a high calcium content and plants of serpentine soils had a high magnesium content, while plants of the non-calcareous soils also had a higher potassium content than those of calcareous soils. He concluded that calcium and magnesium were, to a certain extent, mutually interchangeable in plants and played similar roles for which one was as good as the other. In view of his findings he dismissed Lowe's theory that calcium and magnesium levels were constant for each plant species. The present work partly confirms Zlatnik's findings.

The inference is, then, that in the British Isles we have two principle edaphic ecotypes of Sesleria, one on calcareous soils and the other on serpentine or related soils, i.e. a "calcicole" and a "magnesicole", but we should be careful of too unequivocal an

application of these designations. The former in particular is of doubtful authenticity and its disputation is the main concern of this piece of research.

Bradshaw and Snaydon (1959) shewed that the existence of edaphic ecotypes is probably more widespread and common than previously imagined. A considerable volume of literature exists on this problem and much of the work has been in connection with the evolution of heavy metal tolerant plant varieties. Bradshaw (1952) found populations of Agrostis tenuis tolerant of concentrations of lead and zinc in soils of lead mine spoil heaps. Jowett (1959) confirmed these findings. Bradshaw and Snaydon (op. cit., 1959) shewed the existence of edaphic ecotypes of Festuca ovina but Wilkins' (1957) work on Festuca ovina and Deschampsia flexuosa is perhaps the most relevant to the present problem. Their experiments with plants of these species from lead mines in Scotland shewed that the toxicity of lead was greatly reduced by the presence of other salts. ~~Three parts per million of lead was greatly reduced by the presence of other salts.~~ Three parts per million of lead in a pure solution were found to be highly toxic to plants but in Knopp's solution many plants shewed few ill effects at concentrations of up to 25 p.p.m. of lead. It was found that the calcium ion was the one that had the antagonistic effect to lead. Jowett (1958) supports the hypothesis that strains of plants resistant to certain minerals have some selective internal fixing mechanism for Cu, Ni, Zn, Pb etc. such as chelation. Plants

would have a specific chelation process according to the toxic element in which they are forced to grow.

Lead mines are scattered widely throughout the Upper Teesdale valley and although the Poa plants were taken from a more distant site there were old mine workings very close to the main Sesleria site in Teesdale. It seems quite credible that there was a fairly high level of lead and zinc in the soils of much of the area and not just at the Rowan Tree site, though these metals would obviously be concentrated in the spoil heaps themselves. The effect of the calcium ion concentration in the soil is to neutralize the toxicity of lead. This is the only (as far as existing knowledge goes) plausible explanation of the greater tolerance for lead and zinc possessed by the Teesdale plants compared with Cassop plants. However, it should be emphasised that there is no question of proof here and this is only a possible hypothesis.

One angle from which the present problem has not been studied is that of soil reaction. This question was examined by Zlatnik (op. cit.) in some detail. He concluded from his experiments that the reaction of the plant substrate was of prime importance to the performance of the plant. He summarized his arguments by concluding that Sesleria could not be called a "calcicole", being tied neither to a finite quantity of  $\text{CaCO}_3$ , nor to a greater quantity of exchangeable calcium in the soil than other plants. Its natural distribution, he considered, was determined in the first instance by

the reaction of the soil, and its establishment, more or less restrictively on soils of certain types was a function of competition with other species.

By culture experiments Zlatnik shewed that the growth curve of Sesleria had its first maximum at pH 5.5, a minimum at pH 6.0 and a second maximum at pH 7.0. The true optimum seemed to be in an alkaline medium, but his experimental technique precluded extension of the growth curve into the alkaline pH range. The neutral reaction optimum was confirmed in the field and one specimen of Sesleria was also found growing in an acid soil. Since the plant was relatively prosperous in reactions in culture other than the optimum it does not preclude the possibility that it might grow in soils of other reactions. The almost exclusive appearance of Sesleria in soils of optimal pH, he felt, could probably be explained by competition.

It is not intended here to go into the arguments of the calcicole problem in general as they have been debated many times over before and it is felt that a more comprehensive account can be obtained by reference to some of the works cited in the bibliographic list at the end of this dissertation. The problem as it concerns us here is admirable summarized by Salisbury (1920):

"In considering so-called calcicolous species we must therefore recognize that we are dealing with plants which find a suitable home on calcareous soils without necessarily implying any obligatory association with, or even preference for, such soils apart from that imposed by climatic or biotic factors."

## Chapter 7. SUMMARY AND CONCLUSIONS

In the British Isles we have Sesleria growing on calcareous soils but only in the northern and extreme western regions. This indicates that some other factor besides calcicolity affects the distribution. The geographical pattern of its distribution suggests some climatic factor; its calcareous locations are high up (cold and wet) or towards the west (high rainfall), but it also grows in non-calcareous soils in other areas. The inference is that Sesleria is only calcicolous at the climatic limits of its range (hence its absence from calcareous soils in the south), i.e. it is a "marginal calcicole" (sensu Clymo, 1962).

An explanation which may either be alternative or supplementary can be based on Zlatnik's findings. If the soil reaction is critical to the successful establishment of Sesleria its absence from the calcareous soils of the south may be due to the more acid reaction of many of these soils. Jefferies and Willis (1964) gave examples of soils developed on Carboniferous Limestone in Somerset with a pH as low as 6.1. Even if Sesleria was able to establish itself on an acid soil its success would probably be jeopardised by competition. Similarly, its exclusion from calcareous soils (assuming a suitable pH value) of more equable climatic regions may well be a function of competition. This theory of Sesleria's relationship with soil reaction could only be proved by measuring the pH of soils in all the places where it is found. The question of competition would have to be solved by the most detailed phytosociological studies.

Many of the soils in Sesleria's non-calcareous habitats seem to be developed on substrates rich in magnesium. To find out to what extent this relationship holds true one would have to perform chemical analyses of soils from all the sites. The inference here is that magnesium plays some critical role in the plant's function and performance. This role has been examined by culture experiments which suggest that magnesium may, to some extent, be an alternative to calcium in the nutrient dynamics of certain populations of the plant. The plants of these populations might therefore be called "magnesicoles".

Possible answers to the first of the two questions posed in chapter 2 (see page 6) have now been proposed. To attempt to answer the second question we must turn to the results of the studies of the two populations.

The results of anatomical studies shewed marked differences between the two populations which were probably a function of climate. The Teesdale plants possess a thicker and tougher tissue 'skeleton' which allows them to survive in very harsh climatic conditions. Plants of the two populations differed somewhat in their mineral relationships, the Cassop plants having a distinct affinity for magnesium while the Teesdale plants have a greater affinity for calcium. Furthermore, Teesdale plants appear to possess a degree of tolerance to lead and zinc not displayed by the Cassop population.

Any conclusions we may reach from this must be regarded as tentative, and further proof would necessitate detailed studies of individual aspects of the problem which were beyond the scope of this work. Nevertheless, the indications are that in Cassop Vale and Upper Teesdale we have two distinct populations of Sesleria belonging to different ecotypes. The grasses as a whole seem to be particularly capable of a great degree of ecotype variation and Sesleria is probably no exception. One must envisage the possibility that these two populations are very localised ecotypes slightly different from other populations elsewhere. The Cassop population may well be an edaphic ecotype that is transitional between the plants of true calcareous soils and those of serpentine soils. It seems to be adapted to make good use of the relatively abundant magnesium in this magnesian limestone soil in a way which the Teesdale plants are not.

The Teesdale population appears to be a climatic ecotype (based on the anatomical evidence) belonging to the 'marginal calcicole' group. It is adapted to the extreme climate and is probably successful in competition on the calcium-rich soil because of this whereas it would be out-competed in similar soils further south. Whether the apparent tolerance of heavy metals is real or not has not been established. It may just be that the effects of lead and zinc (if they are present) are neutralized by the calcium in the soil.

To conclude, Sesleria caerulea in the British Isles, and more particularly in Upper Teesdale and Cassop Vale, does not seem to be a true and pure calcicole, has a more restricted edaphic tolerance than many other grasses and is probably subject to considerable ecotype variation.

## REFERENCES

- ALLEN, J. E. (1958). "Atomic absorption spectrophotometry with special reference to the determination of magnesium."  
Analyst, 83; 466
- BELLAMY, D. J. & HOLLAND, P. J. (1966). "Determination of the net annual aerial production of Calluna vulgaris (L.) Hull, in northern England."  
Oikos, 17; 272-275
- BRADSHAW, A. D. (1952). "Populations of Agrostis tenuis resistant to lead and zinc poisoning."  
Nature, 169; 1098
- BRADSHAW, A. D. et. al. (1958). "Experimental investigations into the mineral nutrition of several grass species. Part I. Calcium level."  
J. Ecol., 46; 749-757
- BRADSHAW, A. D. et. al. (1960). "Experimental investigations into the mineral nutrition of several grass species. Part II. pH and calcium level."  
J. Ecol., 48; 143-150
- BRADSHAW, A. D. et. al. (1960). "Experimental investigations into the mineral nutrition of several grass species. Part III. Phosphate level."  
J. Ecol., 48; 631-637
- BRADSHAW, A. D. et. al. (1964). "Experimental investigations into the mineral nutrition of several grass species. Part IV. Nitrogen level."  
J. Ecol., 52; 665-676
- BRADSHAW, A. D. & SNAYDON, R. W. (1959). "Population differentiation within plant species in response to soil factors."  
Nature, 183; 129
- CHAPMAN, V. J. Salt marshes and salt deserts of the world.  
New York, 1960.

- CLYMO, R. S. (1962). "An experimental approach to part of the calcicole problem."  
J. Ecol., 50; 707-731
- COLLANDER, R. (1941). "Selective absorption of cations by higher plants."  
Plant Physiol., 16; 691
- DAVID, D. J. (1958). "Determination of zinc and other elements in plants by atomic absorption spectroscopy."  
Analyst, 83; 655-661
- DAVID, D. J. (1959). "Determination of calcium in plant material by atomic absorption spectrophotometry."  
Analyst, 84; 536-545
- DE SILVA, B. L. T. (1934). "The distribution of calcicole and calcifuge species in relation to the content of the soil in calcium carbonate and exchangeable calcium, and to soil reaction."  
J. Ecol., 22; 532-553
- DUVAL-JOUVE, J. (1875). "Histotaxie des feuilles de graminées."  
Ann. Sti. nat.b, Ser.6. 1: 294-371
- FAWZY et. al. (1954). in GAUCH (1957)
- GAUCH, H. G. (1957). "Mineral nutrition of plants"  
Ann. Rev. Plant Physiol., 8; 31-63
- GREGORY, R. P. G. & BRADSHAW, A. D. (1965). "Heavy metal tolerance in populations of Agrostis tenuis Sibth. and other grasses."  
New Phytol., 64; 131-143
- HEGI, G. Illustrierte Flora von Mittel-Europa.  
Band. I.  
Carl Hanser/Verlag/Munchen, 1909
- HEWITT, E. J. (1951). "The role of the mineral elements in plant nutrition."  
Ann. Rev. Plant Physiol., 2; 25-52
- HEWITT, E. J. Sand and Water Culture Methods used in the Study of Plant Nutrition.  
(Commonwealth Bureau of Horticulture and Plantation Crops, Technical Communication 22.)  
Farnham Royal, 1952.

- HUBBARD, C. E. Grasses. Penguin Books Ltd.  
Harmondsworth, 1968.
- HULTEN, E. Atlas of the Distribution of Vascular  
Plants in N. W. Europe. Stockholm, 1950.
- JAMES, D. B. (1962). "Factors affecting the growth  
of Molinia caerulea on a calcareous soil."  
J. Ecol., 50; 521-527
- JEFFERIES, R. L. & WILLIS, A. J. (1964). "Studies on  
the calcicole-calcifuge habit."  
I. Methods of analysis of soil and plant tissues  
and some results of investigations of four species.  
J. Ecol., 52; 121-137
- JEFFERIES, R. L. & WILLIS, A. J. (1964). "Studies on  
the calcicole-calcifuge habit."  
II. The influence of calcium on the growth and  
establishment of four species in soil and sand  
cultures.  
J. Ecol., 52; 691-707
- JOHAM (1955). in GAUCH (1957)
- JOWETT, D. (1958). "Populations of Agrostis spp.  
tolerant of heavy metals."  
Nature, 182; 816
- JOWETT, D. (1959). "Adaptation of a lead-tolerant  
population of Agrostis tenuis to low soil fertility."  
Nature, 184; 43
- JOWETT, D. (1964). "Population studies on lead-tolerant  
Agrostis tenuis."  
Evolution, 18; 70-80
- KRUCKEBERG, A. R. (1957). "Intra-specific variability in  
the response of certain native plant species to  
serpentine soils."  
Amer. J. Bot., 38; 408
- KRUCKEBERG, A. R. (1954). "Plant species in relation to  
serpentine soils."  
Ecology, 35; 267

- LOWE, E. J. A Natural History of British Grasses.  
London, 1865
- METCALFE, C. R. Anatomy of the Monocotyledons.  
Oxford, Clarendon Press, 1960
- NIELSEN & OVERSTREET (1955). in GAUCH (1957)
- OLSEN, C. (1923). in ZLATNIK (1928)
- OLSEN, C. (1942). in JEFFERIES & WILLIS (1964)
- OVERSTREET, et. al. (1952). in GAUCH (1957)
- PIGOTT, C. D. (1956). "The vegetation of Upper Teesdale  
in the North Pennines."  
J. Ecol., 44; 545-586
- RIELEY, J. O. (1967). The Ecology of Carex flacca and  
C. panicea.  
Ph.D. Thesis. Durham, 1967
- ROBERTSON, R. N. (1958) "The uptake of minerals."  
Encyclopedia of Plant Physiology, Vol. IV.  
Mineral Nutrition of Plants.  
Berlin.
- SALISBURY, E. J. (1920). "The significance of the  
calcicolous habit."  
J. Ecol., 8; 202-215
- SNAYDON, R. W. & BRADSHAW, A. D. (1961) "Differential  
responses to calcium within the species Festuca  
ovina L."  
New Phytol., 60; 219-234
- SOWERBY, J. E. The Grasses of Great Britain.  
London, c. 1862
- SUTCLIFFE, J. F. Mineral Salts Absorption in Plants.  
Pergamon Press, 1962
- TOTTINGHAM, W. E. (1914). in ZLATNIK (1928)
- WALKER, R. B. et. al. (1955). "Calcium-magnesium  
nutrition with special reference to serpentine  
soils."  
Plant Physiol., 30; 214-221

WILKINS, D. A. (1957). "A technique for the measurement of lead tolerance in plants."

Nature, 180; 37-38

WILKINS, D. A. (1960). "The measurement and genetical analysis of lead tolerance in Festuca ovina."

Scottish Plant Breeding Station

Rep. 1960; 85-98

ZLATNIK, A. (1928). "Études écologiques et sociologiques sur la Sesleria caerulea et la Seslerion calcariae en Tchêcoslovaquie."

Trav. de la Soc. Roy. des Sci. de Bohême, Cl. de Sci. N.S. 8: 1-116

