

## Durham E-Theses

---

### *The glacial history and deposits of a selected part of the alston block*

Vincent, Peter John

#### How to cite:

---

Vincent, Peter John (1969) *The glacial history and deposits of a selected part of the alston block*, Durham theses, Durham University. Available at Durham E-Theses Online:  
<http://etheses.dur.ac.uk/8730/>

#### Use policy

---

The full-text may be used and/or reproduced, and given to third parties in any format or medium, without prior permission or charge, for personal research or study, educational, or not-for-profit purposes provided that:

- a full bibliographic reference is made to the original source
- a [link](#) is made to the metadata record in Durham E-Theses
- the full-text is not changed in any way

The full-text must not be sold in any format or medium without the formal permission of the copyright holders.

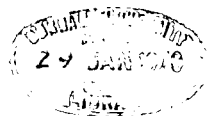
Please consult the [full Durham E-Theses policy](#) for further details.

The Glacial History and Deposits of a  
Selected Part of the Alston Block

by

Peter John Vincent B.Sc. (Sheffield)

A thesis submitted for the degree of  
Doctor of Philosophy in the University  
of Durham, October 1969.



## ABSTRACT.

This thesis is concerned with a study of the glaciation and glacial deposits of a selected part of the South Tyne and Allendale valleys. The results which are presented in this thesis were obtained both from laboratory analyses of the till sediments and from field observations in an attempt to make the study as integrated as possible. The thesis is divided into four sections.

The introductory section is a description of the study area in terms of its physical geography and geology. In order to put the present work into context the history of previous glacial research is also outlined.

In section two the glacial sediments and landforms are described and the writer's findings are discussed in the light of the previous work.

Section three is a sedimentological study of the till deposits and is the only data of its kind yet available for this part of northern England.

Section four, the synthesis, is a quantitative and qualitative assessment of the raw data described in the preceding section of this thesis. Two chapters are concerned with a statistical synthesis, while a third is a subjective appraisal of the ice movements of the last glaciation.

Frontispiece.



South Tyne valley north of Slaggyford - view looking  
towards the Tyne Gap.

## ACKNOWLEDGEMENTS.

I should like to take this opportunity to express my appreciation to Professor W. B. Fisher for accepting me as a research student in the Department of Geography, University of Durham, and also for providing a wealth of equipment without which this study could not have been attempted.

I am most grateful for the receipt of an N.E.R.C. research studentship which enabled me to pursue my research for the last three years.

I should like to thank the staff of the University of Durham Science Library and the University of Durham Computing Unit who put up with my endless requests and who withstood my inadequacies as a computer programmer.

My thanks also go to Dr. K. Atkinson, Mr. E. A. Francis, Mr. A. R. Lockery, Mr. J. Stevens and Mr. J. Young who provided willing counsel on a great many occasions.

Above all I should like to thank Dr. P. Beaumont for his constant encouragement, assiduous supervision and friendliness.

## TABLE OF CONTENTS.

	<u>Page.</u>
Abstract.	ii.
Frontispiece.	iii.
Acknowledgements.	iv.
Table of Contents.	v.
List of Figures.	vi.
List of Plates.	ix.
List of Tables.	xi.
List of Appendices.	xii.
Introduction.	1.
Section 1. <u>Introductory Section.</u>	3.
Chapter 1. Relief and Drainage.	4.
Chapter 2. Geology.	12.
Chapter 3. History of Previous Research.	29.
Section 2. <u>A Description of the Glacial sediments and Landforms.</u>	47.
Chapter 4. The Glacial Deposits.	48.
Chapter 5. Meltwater Channels.	78.
Section 3. <u>Sediment Analyses.</u>	127.
Chapter 6. Stone Orientations and Striae.	128.
Chapter 7. Stone Counts.	145.
Chapter 8. Particle Size Analysis.	162.
Chapter 9. Chemical Analyses.	213.
Chapter 10. X-ray and Heavy Mineral Analyses.	229.
Section 4. <u>Synthesis.</u>	258.
Chapter 11. Factor Analysis.	259.
Chapter 12. Trend Surface Analysis.	275.
Chapter 13. Ice Movements in the South Tyne and Allendale valleys.	298.
Chapter 14. Conclusions.	313.
Bibliography.	320.
Appendices.	340.

## LIST OF FIGURES.

<u>Figure.</u>	<u>Page.</u>
1.1 The limits of the study area.	5.
1.2 Relief and drainage.	7.
1.3 Valley cross profiles.	9.
2.1 Main lithological types in northern England and southern Scotland.	15.
2.2 Structure of the Alston Block-in plan.	17.
2.3 Structure of the Alston Block-in section.	20.
2.4 Geological sections of the Alston Block.	22.
2.5 A Yoredale Cyclothem.	24.
2.6 The Geology of the study area.	27.
3.1 Ice movements in the northern Pennines according to Derryhouse (1902).	32.
3.2 Glacially-dammed lakes according to Derryhouse (1902).	34.
3.3 Ice movements according to Trotter (1929a).	37.
3.4 Ice movements according to Raistrick (1931).	39.
3.5 Ice-dammed lakes in the northern Pennines according to Raistrick (1932).	41.
4.1 The Distribution of erratic material on the Cold Fell-Hartside Height watershed.	49.
4.2 The distribution of till in the study area.	56.
4.3 Fluvioglacial features in East Allen Dale.	67.
4.4 Profiles of the ice-surface in Edenside based on the limit of erratics on the Cold Fell-Hartside Height watershed.	75.
5.1 A model of meltwater environments.	84.
5.2 The Butt Hill Col channel.	86.
5.3 Meltwater channels around Slaggyford.	89.
5.4 Meltwater channels in Thornhope valley.	95.
5.5 Meltwater channels around Alston.	97.

<u>Figure.</u>	<u>Page.</u>
5.6 Meltwater channels in upper West Allen Dale.	101.
5.7 Meltwater channels on Ouston Fell.	103.
5.8 Meltwater channels in the lower West Allen Dale.	105.
5.9 Meltwater channels around Allenheads.	108.
5.10 Meltwater channels on Allendale common.	111.
5.11 Meltwater channels around Sinderhope.	116.
5.12 Meltwater channels on Eshells Moor.	123.
5.13 Major meltwater channels in the north-west Pennines.	125.
6.1 Rose diagrams of stone orientations.	131.
6.2 Ice directions based on stone orientations.	141.
7.1 Location of sampling sites.	154.
7.2 Relationship between distance and limestone content in the tills of the South Tyne valley.	158.
8.1 Histograms of sand, silt and clay percentages of the tills.	169.
8.2 Triangular diagrams of sand, silt and clay contents of the tills.	172.
8.3 Particle size curves of till samples.	181.
8.4 Histograms of phi median particle size.	193.
8.5 Histograms of phi mean particle size.	197.
8.6 Histograms of phi sorting.	198.
8.7 Relationship between phi sorting and phi mean particle size.	199.
8.8 Histogram of phi skewness.	201.
8.9 Relationship between phi mean and phi skewness.	202.
8.10 Analyses of Lacustrine deposits.	208.
9.1 Histogram of carbonate contents of the till.	215.
9.2 Histogram of pH values of the till.	221.
9.3 Relationship between carbonate contents and the pH of the tills.	222.
9.4 The relationship between the colour and ferric iron content of the tills.	225.
9.5 Histogram of the coal content of the tills.	227.



<u>Figure.</u>	<u>Page.</u>
10.1 X-ray diffraction curves for sample at 713469.	235.
10.2 X-ray diffraction curves for sample at 761490.	237.
10.3 X-ray diffraction curves for sample at 852471.	239.
10.4 X-ray diffraction curves for sample at 652598.	241.
10.5 X-ray diffraction curves for sample at 675555.	243.
10.6 Percentages of opaque minerals in the tills.	255.
11.1 Procedures in factor analysis.	261.
11.2 Factor loadings I and II.	270.
11.3 Factor loadings I and III.	271.
11.4 Factor loadings II and III.	272.
12.1 Linear trend surface.	276.
12.2 Sampling sites for trend surface analysis.	282.
12.3 Trends of the erratic content of the tills.	285.
12.4 Types of ice movement across a watershed.	287.
12.5 Trends of the greywacke content of the tills.	289.
12.6 Trends of the tourmaline content of the tills.	291.
12.7 Trends of the limestone content of the tills.	293.
12.8 Trends of the phi mean particle size of the tills.	296.
13.1 Ice movements at the maximum of the last glaciation.	302.
13.2 Ice movements at a late stage A of the last glaciation.	307.
13.3 Ice movements at a late stage B of the last glaciation.	310.

## LIST OF PLATES.

<u>Plate.</u>	<u>Page.</u>
Frontispiece.	iii.
4.1 Drab-coloured till exposed in the Thornhope Burn.	52.
4.2 Reddish-coloured till exposed in the Gelt Burn.	52.
4.3 Till exposed on the spur between the Knar and Gelt Burns.	54.
4.4 The asymmetry of the West Allen valley.	54.
4.5 The juxtaposition of erratic-free and erratic-containing tills north-west of Allendale Town.	59.
4.6 Till exposed in the banks of the East Allen valley near the confluence with the West Allen valley.	60.
4.7 Kames at Coanwood in the South Tyne valley.	60.
4.8 Marginal lacustrinal facies exposed at Knockshield.	70.
4.9 Details of a rhythmic silty horizon in the Knockshield Burn.	71.
5.1 Aerial view of Beldon Clough.	87.
5.2 Butt Hill Col Channel.	87.
5.3 Channel b (Fig. 5.3).	90.
5.4 Upper part of channel b (Fig. 5.3).	90.
5.5 The mouth of channel b (Fig. 5.3).	92.
5.6 Channel c (Fig. 5.4).	92.
5.7 Channel d (Fig. 5.4).	94.
5.8 Ice-marginal bench in the Thornhope Burn complex. (Fig. 5.4).	94.
5.9 Channel f (Fig. 5.5).	98.
5.10 Channel k (Fig. 5.5).	98.
5.11 Channel d (Fig. 5.6).	102.
5.12 Channel a (Fig. 5.7).	102.
5.13 Channel a (Fig. 5.9).	109.
5.14 Channel b (Fig. 5.9).	109.

<u>Plate.</u>	<u>Page.</u>
5.15 Channel a (Fig. 5.10).	112.
5.16 Channel b (Fig. 5.10).	112.
5.17 Mouth of channel f (Fig. 5.10).	113.
5.18 Aerial view of channel f (Fig. 5.10).	114.
5.19 Channel e (Fig. 5.10).	114.
5.20 Channel g (Fig. 5.10).	115.
5.21 Lower part of channel a (Fig. 5.11).	120.
5.22 Upper part of channel a (Fig. 5.11).	121.
5.23 Sipton Clough - channel m (Fig. 5.11).	122.
8.1 Thin section of rhythmic silt.	211.

LIST OF TABLES.

<u>Table.</u>	<u>Page.</u>
1.1 The erosion surfaces of the northern Pennines.	6.
3.1 Correlations of glacial deposits in northern England.	40.
6.1 Results of two dimensional fabric analysis.	139.
7.1 Results of stone count analysis.	149.
8.1 Sand, silt and clay percentages of the tills.	166.
8.2 Conversion table for millimetres to phi units.	168.
8.3 Results of particle size analyses.	175.
8.4 Results of statistical analyses.	194.
8.5 Correlations of lithological and particle size parameters.	204.
9.1 Carbonate, pH, coal and ferric iron values and the Munsell chart colour of the tills.	218.
10.1 Results of heavy mineral analyses.	250.
11.1 Factor weightings for variables.	265.
11.2 Factor loadings for samples.	267.

LIST OF APPENDICES.

<u>Appendix.</u>	<u>Page.</u>
1. Map references of place names in the study area mentioned in the text.	341.
2. Particle size analysis - methods.	343.
3. Stone orientations - raw data.	352.
4. Determination of the calcium carbonate content of the tills.	355.
5. Determination of the ferric iron content of the tills.	356.
6. Determination of the coal content of the tills.	358.
7. Preparations of thin sections of laminated clays.	360.

## INTRODUCTION.

This thesis is concerned primarily with a study of the till deposits and glaciation of the north-west Alston Block. The north-west Alston Block is here defined as East and West Allen Dale, from their southern watershed to their confluence, and the South Tyne valley, from Alston to Harper Town (Fig. 1.1). The study area thus consists of some 140 square miles of Pennine moorland.

The methods of analysis used in this thesis are a mixture of old and new, partly undertaken in the field and partly in the laboratory.

The thesis is divided into four sections.

### Section I. Introductory Section.

In this introductory section the study area is described in terms of its physical geography and geology. An outline is also presented of the previous glacial research in the northern Pennines.

### Section 2. A Description of the Glacial Sediments and Landforms.

This section includes descriptions of the glacial sediments and landforms as seen in the field and very largely covers the information provided by previous workers in the area. A few sediment samples were also collected from outside the defined study area so as to provide comparative data.

### Section 3. Sediment Analyses.

The data produced in section three of this thesis are the outcome of a laboratory and field investigation of the till deposits and

are the only data of their kind yet available for this part of northern England.

Section 4. Synthesis.

Section four of this thesis is a synthesis of the quantitative and qualitative information provided earlier in this study. Two chapters are concerned with a statistical synthesis while a third is an appraisal of the events of the last glaciation based on the preceding chapters.

Section I.

INTRODUCTORY SECTION.



## Chapter I.

### RELIEF AND DRAINAGE.

#### Introduction

"The northern Pennine moorlands comprise the most consistently elevated and chilly part of England. It is higher and bleaker than Dartmoor or of any of the extensive Welsh Uplands. As a whole the figures confirm the prevailing impression of bleakness associated with a windy and damp upland and correspond well with records at sea-level in southern Iceland".

Manley (1936)

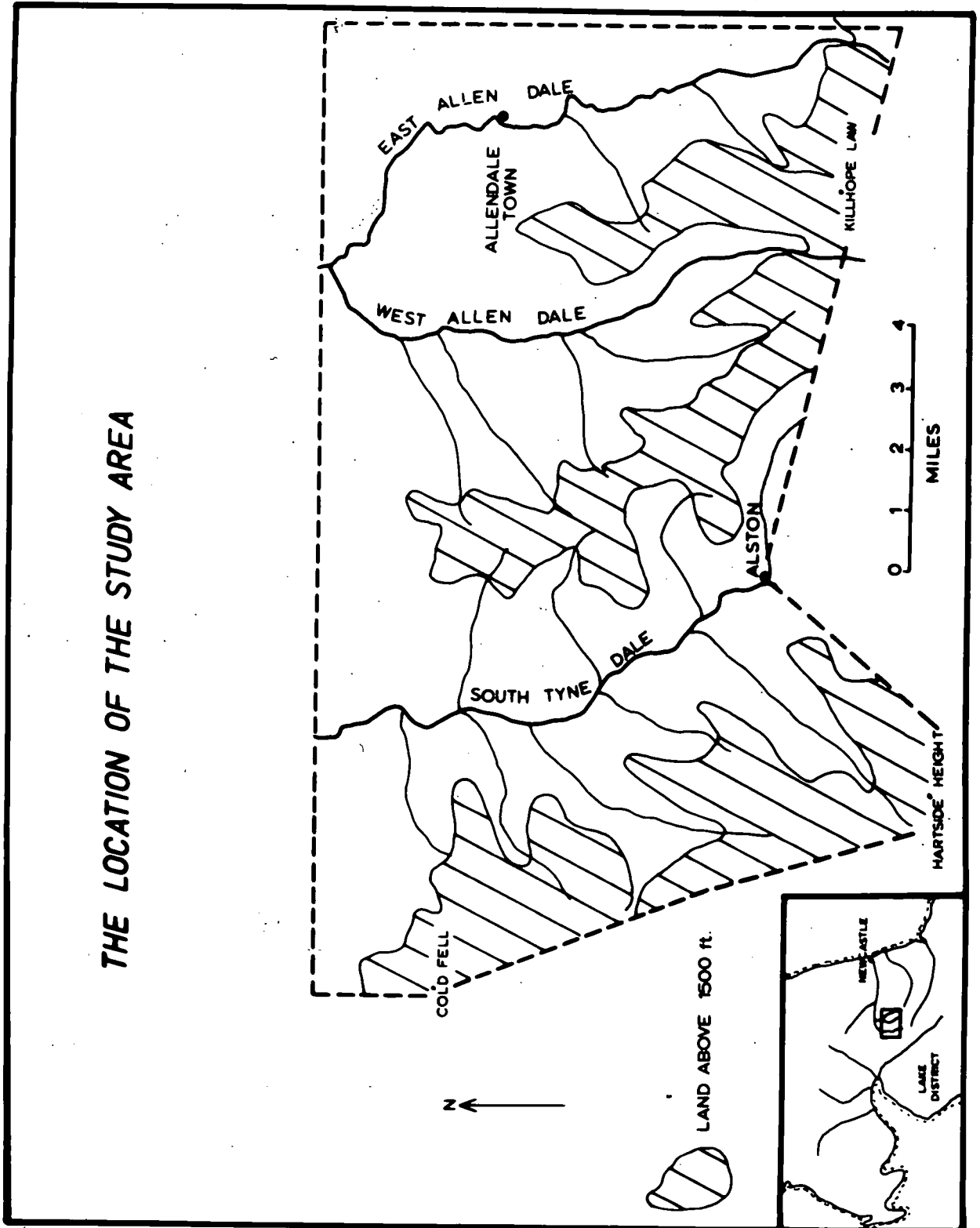
This most graphic description by Manley portrays well much of the natural environment of the moorlands which form the larger part of the research area, as defined in the introductory section of this thesis. The location of the study area within its regional context is shown in Figure 1.1.

#### A. Relief.

Figure 1.2 illustrates the nature of the relief. Tracts of high bleak moorland are enclosed on the west and south by major interfluves. The western interfluve, stretching northwards from the Cross Fell massif, is a major relief feature much of which is above 1800 feet O.D. Several of the higher peaks are above 2000 feet O.D. e.g. Cold Fell 2039 feet, Black Fell 2179 feet, and Hartside Height 2046 feet O.D. (Fig.1.2). The southern interfluve dividing the drainage of the East and West Allen from that of the Nent and Wear, is nearly as continuous. East of Killhope Moor (Fig. 1.2) much of this interfluve attains altitudes of more than 2000 feet O.D.

Enclosed within these two high interfluve areas is a great expanse of moorland, a great deal of which lies above 1500 feet O.D. The continuity of this wilderness of peat bog and heather moorland is only broken by the major northward flowing valleys of the South Tyne, East and West Allen Dales.

Fig. 1.1



Three landscape elements are worthy of further mention.

i. Erosion Surfaces.

In upland Britain geomorphologists have, for some time, recognised the existence of erosion surfaces. Much of the bleak moorland previously mentioned bears adequate testimony to the presence of such surfaces. Wright (1955) and Maling (1955) have done much to establish the nature and number of such surfaces in the northern Pennines. The results of their detailed surveys are tabulated below.

Table 1.1. Erosion Surfaces of Northern England.

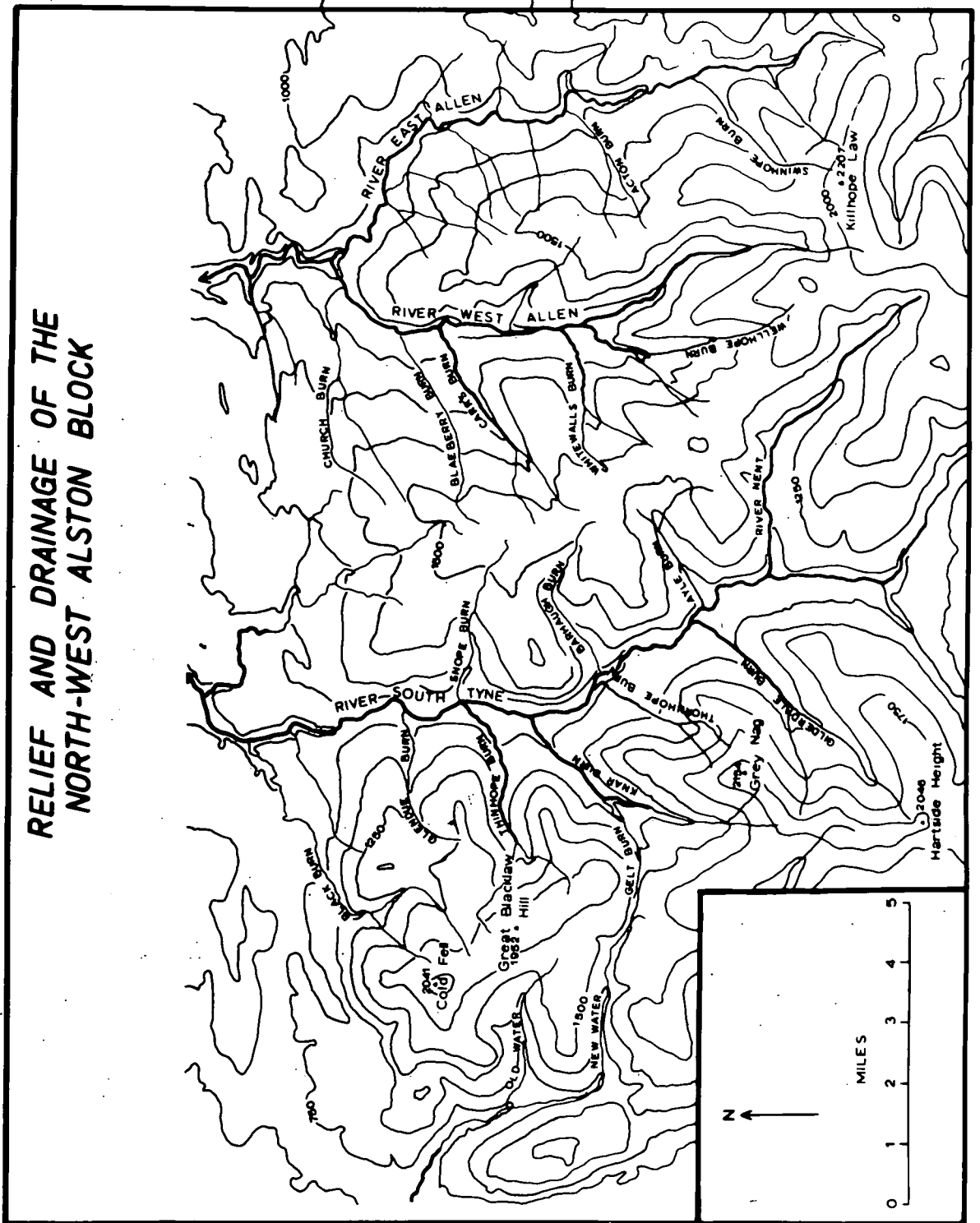
Maling (1955) (Weardale)	Wright (1955) (Teesdale)
-	2700
-	2400-2600
2100-2600	2000
1700-1800	1750-2000
-	1500
1250-1430	1200-1400
1000-1050	1000
720- 900	700- 850
600- 620	550- 650
520- 550	-
400- 450	400- 450
320- 330	250- 350

(All heights are feet above sea-level)

Whether or not the erosion surfaces of the Pennine moorlands are of marine or sub-aerial origin is debatable. A discussion of this topic lies beyond the scope of the present work. For further details the reader is referred to the following: Trotter (1929b), Hollingworth (1938), Wooldridge (1950), Linton (1951), Maling (1955), Wright (1955) and Sissons (1960a).

This topic should not be left without consideration of the vast quantities of glacial deposits now stranded in the valleys of the Alston Block and also an immeasurable amount of sediment which must have been

Fig. 1.2



totally removed from the area. Ice action must have certainly been an effective force in the Pennine Uplands but it is probable that many features, such as the erosion surfaces were merely lowered, in terms of absolute height, rather than being drastically modified.

#### ii. Asymmetric Cross Profiles.

A striking feature of the South Tyne, East and West Allen Dale valleys is the very marked asymmetry of their cross profiles (Fig. 1.3). In many sections it is possible to observe an eastern bank cut into solid rock, often rising precipitously from the valley bottom, while on the western bank there is only a gradual slope up onto the moorland.

An examination of the disposition of the glacial deposits provides valuable clues as to the possible origin of the asymmetry. Almost without exception the east facing valley slopes are plastered with glacial deposits whilst the west facing slopes are often bare of such deposits. As will be shown in chapter 13 such a pattern of deposits is entirely in accord with movements of ice within the region. Beaumont (personal communication) has also suggested that the asymmetry might also in part be due to incision of the valleys into a gently tilted erosion surface.

#### iii. Structural Benches.

One of the most consistent features of the Alston Block is the presence of structural benches. Such benches are best developed where strata of the Yoredale Series crop out. The interbedding of resistant limestones and sandstones with less resistant shales, coals and mudstones is reflected in the benched relief.

Very probably such benches are the results of differential weathering although Trotter (1929a) suggested that in some areas the benched relief may have been accentuated by glacial erosion.

### B. Drainage.

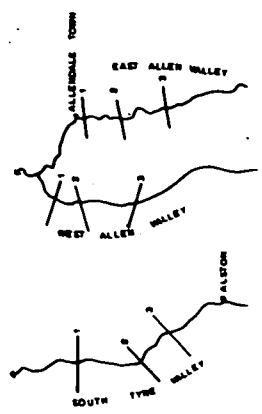
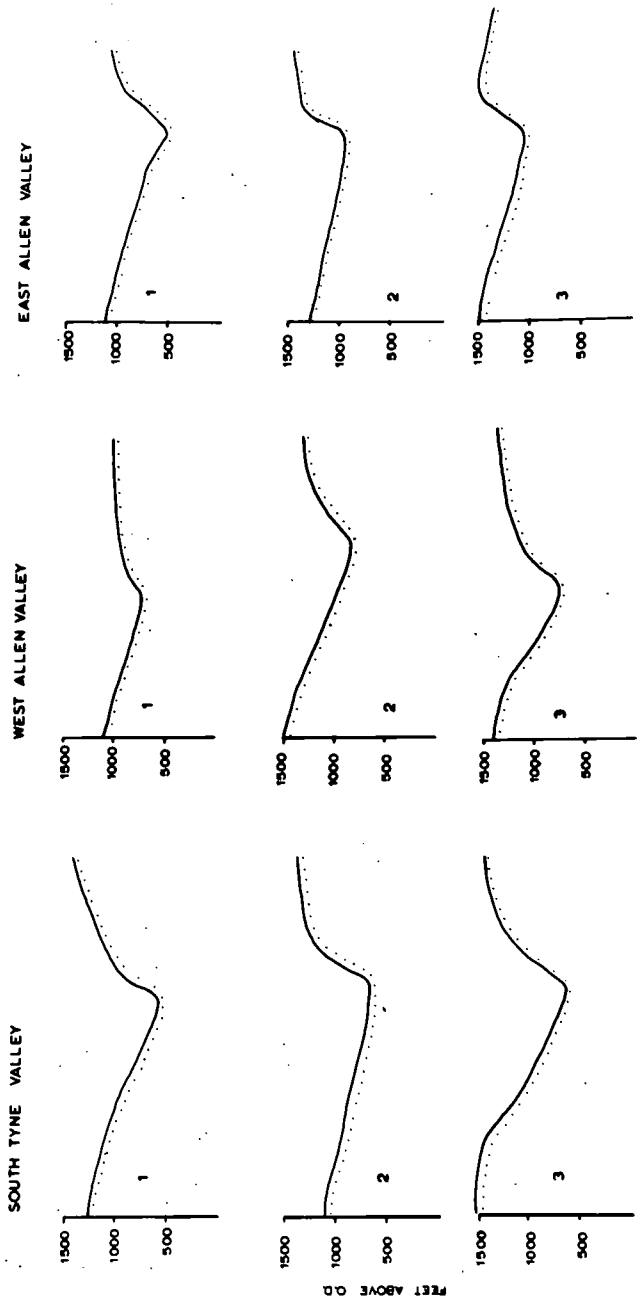
The drainage pattern of the South Tyne and Allendale valleys is relatively simple (Fig. 1.2).

#### i. South Tyne.

The South Tyne enters the area at Alston, having risen some ten miles to the south. Even in so short a distance it has become a sizeable river. For eleven miles or so it flows northwards towards the Tyne Gap.

Fig. 1.3

SELECTED CROSS-PROFILES



0 MILES 2

Vertical Exaggeration x 4:2

A number of tributaries join the main stream, the most important being those which rise on the high ground to the west, namely: Gilderdale Burn, Thornhope Burn, Knar Burn, Thinhope Burn and Glendue Burn.

Some information is available concerning the long profile of this section of the South Tyne. Peel (1966) has described the profile as graded, possibly to a late Pleistocene sea level of -100 feet O.D.

#### ii. West Allen.

The West Allen rises on the high ground of Killhope moor and Slate Hill (Fig. 1.2). For five miles it flows in a northerly direction in a youthful valley cut partly in solid, partly in drift. After its confluence with two important left bank tributaries, the Mohope Burn and Whitewalls Burn, the West Allen valley becomes very open with gentle slopes up to the surrounding moorland. North of Ashes a number of waterfalls are traversed and 100 yards downstream from its confluence with Carr's Burn the West Allen is incised some 30 feet into massive sandstone and limestones. The West Allen continues to flow in a relatively confined valley, enclosed by steep wooded banks, until its confluence with the East Allen.

#### iii. East Allen.

The East Allen rises at c.1950 feet O.D. on the high ground which forms the interfluvium between East Allen Dale and Weardale. In many aspects it is similar to the West Allen. The East Allen receives its most important tributaries from moorland rising to the west (Fig. 1.2). The open aspect of the valley is soon lost below Sipton Shield where the valley has incised itself into solid rock. The East Allen maintains this incised attitude until its confluence with the river West Allen. An examination of the geology shows that the main axis of the East Allen valley appears to be controlled to some extent by a major fault line, the Burtreeford Disturbance (Fig. 2.2).

#### Conclusions.

The physical environment of the north-west Alston Block is one dominated by expanses of bleak moorland, a great deal of which has been reduced by erosional agencies, to subdued relief.

The continuity of the moorlands is broken by the rivers South Tyne, East and West Allen which have cut into the moorland surfaces on

their way to the lower land of the Tyne Gap. These rivers have exposed a variety of rock types, the erosion and weathering of which has produced benched valley sides so typical of the Alston Block.



## Chapter 2.

### GEOLOGY.

#### Introduction.

In the northern Pennines the geomorphological role of the solid geology is an important one. Not only is it an important influence on drainage and relief but it is also one of the prime factors in determining the nature of the glacial deposits.

It has long been known that the northern Pennines have in part been subject to inundations of ice, the gathering grounds of which, may have been many miles distant. The incursive nature of such ice is very evident from the nature of the debris which it carried for it abounds in material foreign to the northern Pennines. For this reason a brief description of the solid geology in those areas adjacent to the Alston Block which either supplied material to, or was in the path of, incursive ice-sheets is necessary.

This account is a synthesis of the following works:-

Bott, M.H.P. 1961; Bott, M.H.P. and Johnson, G.A.L. 1967; Bott, M.H.P. and Masson-Smith, D. 1957; British Regional Geology;- Southern Uplands; Northern England; The Pennines and Adjacent areas; Dunham, K.C. 1948a; Dunham, K.C. 1948b; Dunham, K.C. 1953; Dunham, K.C., Bott, M.H.P., Johnson, G.A.L. and Hodge, B.L. 1961; Goodchild, J.G. 1869; Hickling, H.G.A. 1931; Hollingworth, S.E. 1929; Hudson, R.G.S., Bisat, W.S., Wadsworth, H. and Raistrick, A. 1933; Johnson, G.A.L. 1963; Johnson, G.A.L., Hodge, B.L., and Fairbairn, R.A., 1962; Marr, J.E., 1921; Moorbath, S. and Dodson, M.H. 1961; Shotton, F.W. 1954; Spears, D.A. 1961; Trotter, F.M. 1929b; Trotter, F.M. and Hollingworth, S.E. 1928; Versey, H.C. 1960; Woolacott, D. 1923.

The distribution and character of the more important rock types in areas adjacent to the Alston Block are described (Fig. 2.1), and this

account is followed by a more detailed consideration of the Alston Block itself.

## I. ADJACENT AREAS.

### a. The Lake District.

The intense denudation which followed the dome-like uplift of the Lake District has exposed pre-Carboniferous rocks over a considerable area. Rocks of the Skiddaw Series are extensively exposed in the northern part of the Lake District. These rocks are the oldest to be found in the Lake District and are of Ordovician age. The chief rock types are grits, flags, shales and mudstones all of which have been intensely metamorphosed.

South of the Skiddaw Series are the Borrowdale Volcanic Series, occupying a broad central strip of the Lake District. This suite of rocks, some ten thousand feet in thickness, is composed of lavas, tuffs and agglomerates, with some igneous intrusions, and represents a major period of volcanic activity in late Ordovician times following the deposition of the Skiddaw Series. When volcanic activity waned uplift and gentle folding took place before a return to marine deposition of the succeeding Silurian period.

Rocks of Silurian age are found to the south of a major tear-fault, which runs north-east to south-west from Shap to Broughton-in-Furness. The dominant lithological groups are flags and grits.

Lower Palaeozoic deposition was terminated by the Caledonian Orogeny. Intense compression from the north-west or south-east buckled the Lower Palaeozoic strata and imparted an east-north-east to west-south-west 'Caledonian' grain. The orogeny was accompanied by the intrusion of vast amount of igneous material now seen exposed in the granites of Shap, Skiddaw and Eskdale, the granophyre of Ennerdale and the granophyre-gabbro complex of Carrock.

### b. The Southern Uplands.

In Lower Palaeozoic times this area was the scene of geosynclinal subsidence and deposition, evidence of which is found in the great thickness of shales, mudstones and extensive outcrops of greywacke. In Ordovician times igneous activity was extensive and produced a sequence of lavas, tuffs

and agglomerates. Geosynclinal subsidence and deposition ended with the onset of the Caledonian Orogeny which subjected the area to intense folding and faulting and induced the characteristic belts of north-east to south-west trending strata.

The final effects of the Caledonian Orogenesis was the intrusion, in early Devonian times, of the large granite masses of Criffell, Cairnesmore of Fleet and Loch Doon (Fig. 2.1).

c. Edenside.

Edenside, as defined by Goodchild, (Goodchild, J.G. 1869) is the lowland area between the Lake District and the Pennines. In western Edenside rocks of Lower Carboniferous age flank the Lake District dome and dip steeply towards the Pennine Faults bounding Edenside to the east. It has been shown that Lower Carboniferous sedimentation began earlier in southern Edenside. Furthermore, the deposits thicken rapidly in a southerly direction, there being some 4000 feet of Carboniferous deposits in the Penrith area and only 2000 feet at Caldbeck, some twelve miles to the north.

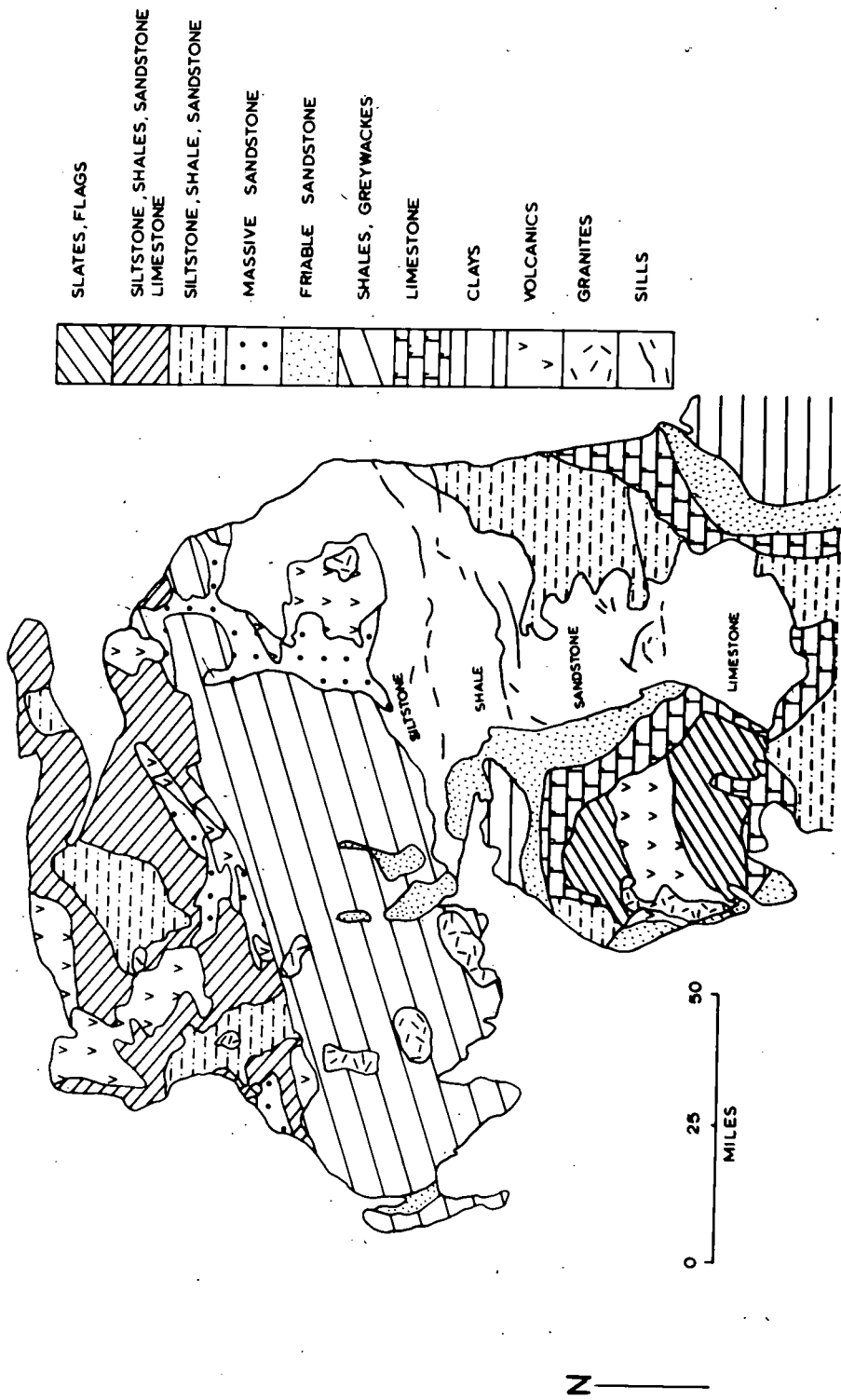
The most important feature of the Lower Carboniferous deposits of Edenside is the dominance of calcareous rocks, this being the type region for marine Lower Carboniferous in the north of England. At the base of these Carboniferous limestones a reddish conglomerate is usually found, which is generally admitted to be of Carboniferous age.

Lying unconformably on the Carboniferous Limestones are the distinctive Permo-Triassic formations. The sequence of Permo-Triassic rocks in Edenside is as follows:-

	Approximate thickness.
Sandstone of Kirklington Type	300 feet.
St. Bees Sandstone	1500 feet.
St. Bees Shales (with Gypsum and Anhydrite beds)	400 feet.
Upper Penrith Sandstone	250 feet.
Upper Brockram	250 feet.
Middle Penrith Sandstone	1000 feet.
Lower Brockram	1500 feet.

Fig. 2.1

MAIN LITHOLOGICAL TYPES



(BASED ON SEVERAL SOURCES)

In Edenside the Penrith Sandstone constitutes the lowest member of the Permo-Triassic system. It is usually a coarse pinkish rock and many of the grains are of 'millet-seed' type suggesting an aeolian origin. Locally beneath the Middle Penrith Sandstone there occurs a breccia or 'brockram' which may be up to 1500 feet thick. A similar brockram occurs between the Middle and Upper Penrith Sandstones.

The succeeding beds, the Upper Penrith Sandstone, St. Bees Shales and St. Bees Sandstone were deposited in water and it is thought that the Zechstein Sea, which was responsible for the Permo-Triassic formations east of the Pennines, incursed temporarily into Edenside creating similar depositional environments, thus accounting for the gypsum and anhydrite beds which occur in the St. Bees Shales.

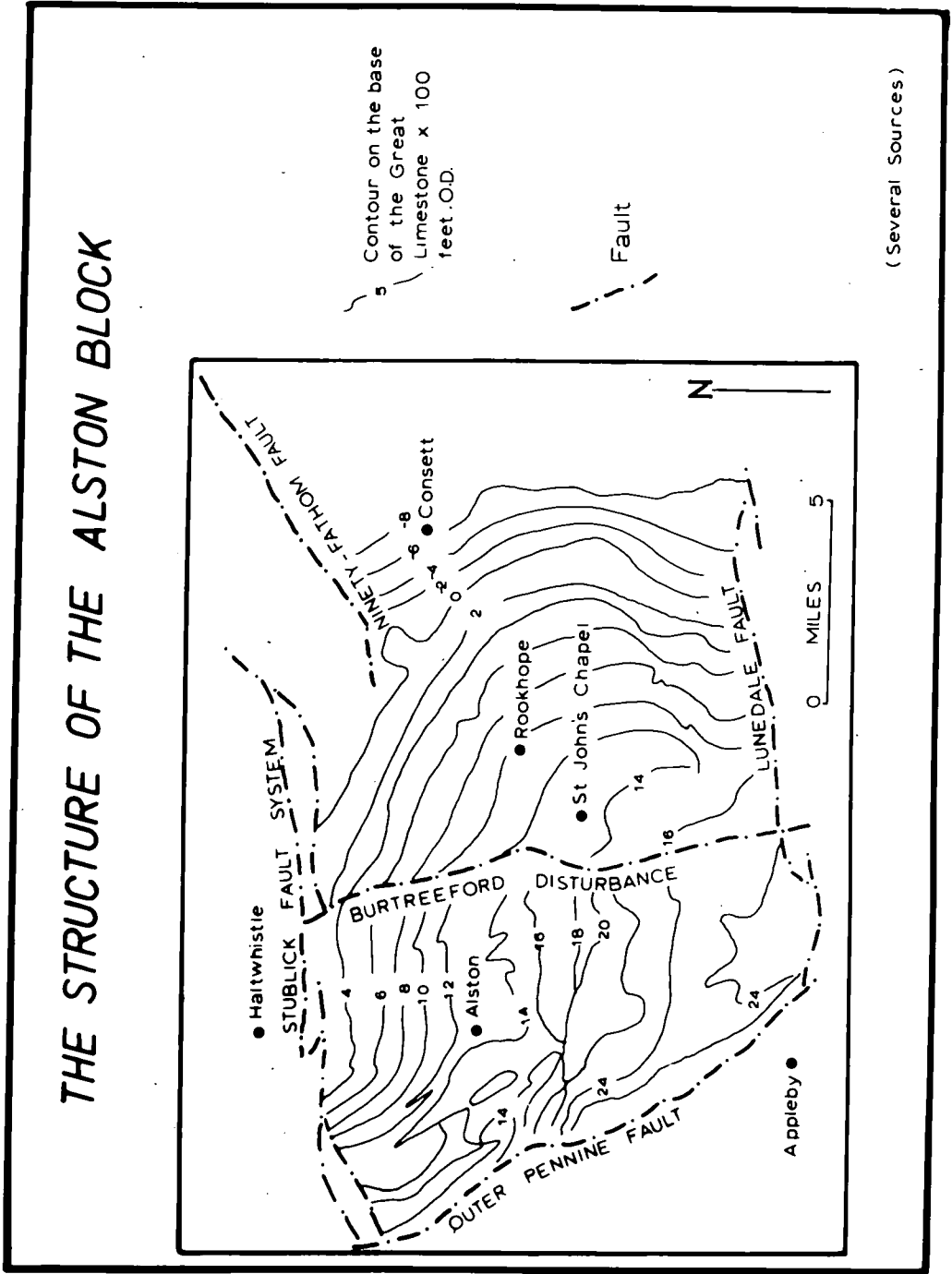
The origin of the red colouration of so much of the Permo-Trias has provoked endless discussion. Dunham (1953) has stated that the red colouration is turgite, an iron oxide, and that in the Permo-Triassic sandstones it forms on each grain a coating which was deposited prior to cementation. The origin of the turgite is ascribed to lateritic weathering under a subtropical humid climate on the land surrounding the Permian deserts. It was then conveyed to shallow lagoons, in which Dunham suggests the sand grains picked up their coating during sedimentation. As Shotton (1954) pointed out a difficulty arises when trying to apply this suggestion to the aeolian deposits. Shotton suggested that capillary movement of dew water and occasional rainfall in the top layers of sand creeping as films over the surfaces and coating the grains with turgite from iron bearing constituents from within the sand itself is a possible explanation.

While the origin of the turgite remains in doubt its distinctive colouration provides a useful feature by which to identify Permo-Triassic erratics.

## 2. THE ALSTON BLOCK.

The northern Pennines from the Tyne valley, in south Northumberland, to the Craven district of Yorkshire, forms a well defined structural unit being bounded on the north, west and south by major fault-systems (Fig. 2.2).

Fig. 2.2.



Recent gravity survey (Bott 1961) shows that there is also a well defined eastern boundary proven some 15 miles off the Durham coast.

#### A. Structural Features.

It is necessary to describe, albeit briefly, the major fault systems associated with the Alston Block for they have played a major role in defining the present day topography.

To the north, the Alston Block is defined by two fault-systems, the Stublick Fault in the west and the Ninety Fathom Dyke in the east. The Stublick Fault-system comprises a belt of east-west to east-north-east faults downthrowing to the north, extending from the neighbourhood of Castle Carrock eastwards to Corbridge. The Stublick system is continued eastward, en echelon, by the Ninety Fathom Faults. The main movement on the Stublick and Ninety Fathom Faults is a downthrow to the north of 500 to 1,750 feet.

The Pennine Fault-system forms the western boundary of the block. There are three principal groups of faults.

- (i) The Inner Pennine Fault downthrowing to the east.
- (ii) A series of thrust faults, along which the overthrusting was directed east-north-east.
- (iii) The Outer Pennine Fault, a great north-north-west system downthrowing to the west some thousands of feet, bringing the Lower Palaeozoic rocks of the Cross Fell inlier against Permo-Triassic rocks of the Vale of Eden.

The southern boundary of the Alston Block is marked by a series of faults which run along the northern edge of the Stainmore Syncline. From west to east they are the Swale Beck, Lunedale, Butterknowle and Wigglesworth faults.

A limited amount of evidence suggests that the eastern boundary of the block is also well defined (Bott, 1961). Gravity survey shows that the edge of the block is marked by a rapid thickening of sediments. Similar hinge-lines have also been proven on the northern, western and southern boundaries of the Alston Block.

The structure of the block itself is comparatively simple. Dunham (1948) suggests that it may be regarded as a gentle asymmetric dome the nearly flat top of which lies beneath the headwaters of the Tees and Maizebeck. To the north and east the beds dip away at an average of 130 feet per mile while to the south the beds dip more rapidly towards the Stainmore Syncline.

The regularity of the dip away from the Teesdale Dome is broken by a number of faults. Statistical analysis (Dunham 1948a) shows that the dominant direction of faulting was north-west south-east with a secondary concentration striking in an east-north-east west-south-west direction.

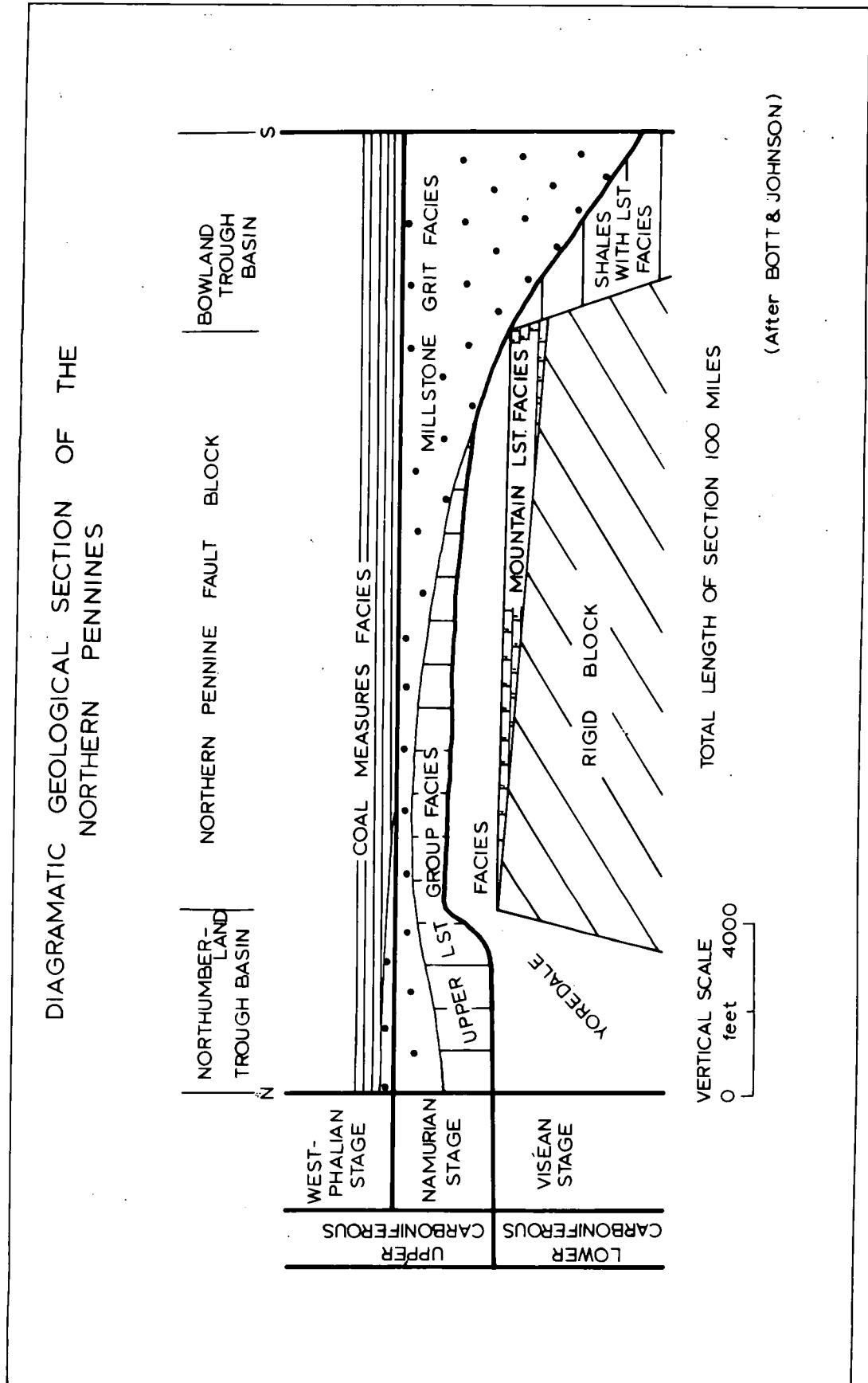
Extending across the area from north south there is a major disturbance known as the Burtree ford Disturbance. Between Elphagreen, in East Allen Dale, and Hargill Beck in Lunedale, the disturbance is an east-facing monocline downthrowing approximately 250 feet.

It is not known for certain when uplift of the block took place. Trotter and Hollingworth (1928b) argued that the Alston Block was not uplifted by Hercynian earth-movements. They suggested that because several of the boundary faults affect Triassic rocks a post-Triassic age for the elevation is probable. Trotter (1929b) has argued from the physiography that a peneplain which was developed over the area after an early Tertiary uplift was subsequently elevated and folded into the Teesdale anticline. Trotter concluded that the age of the main uplift is late Tertiary. Opposing this view, Dunham (1948a), while not rejecting the idea of additional Tertiary warping, concluded that formation and uplift of the block took place during the Hercynian orogeny.

More recently Spears (1961) in a study of joint patterns in the Whin Sill, which he considered to be shear joints originating through a relaxation of stress during uplift, suggested that similar jointing in the Magnesian Limestone is of the same age, therefore lending weight to Trotter and Hollingworth's concept.



Fig. 2.3



## B. The Lower Palaeozoic Foundation.

Older Palaeozoic rocks form the foundation of the Alston Block and lie separated from the overlying Carboniferous succession by a great unconformity (Fig. 2.3). Rocks of Lower Palaeozoic age are exposed in two places on the block at Cross Fell and Cronkley Scar. The Cross Fell Inlier is in the form of a narrow strip lying between the Carboniferous escarpment and the Outer Pennine Fault while the other outcrop lies in the Tees valley below Cronkley Scar. The only other record of these rocks comes from a deep boring at Crook, Co. Durham which proved the presence of Lower Palaeozoic rocks 2827 feet below the surface (Woolacott, 1923).

In the absence of further evidence it seems likely that the Lower Palaeozoic rocks or even older sediments are continuous under the Alston Block except where interrupted by intrusive granite (Fig. 2.3).

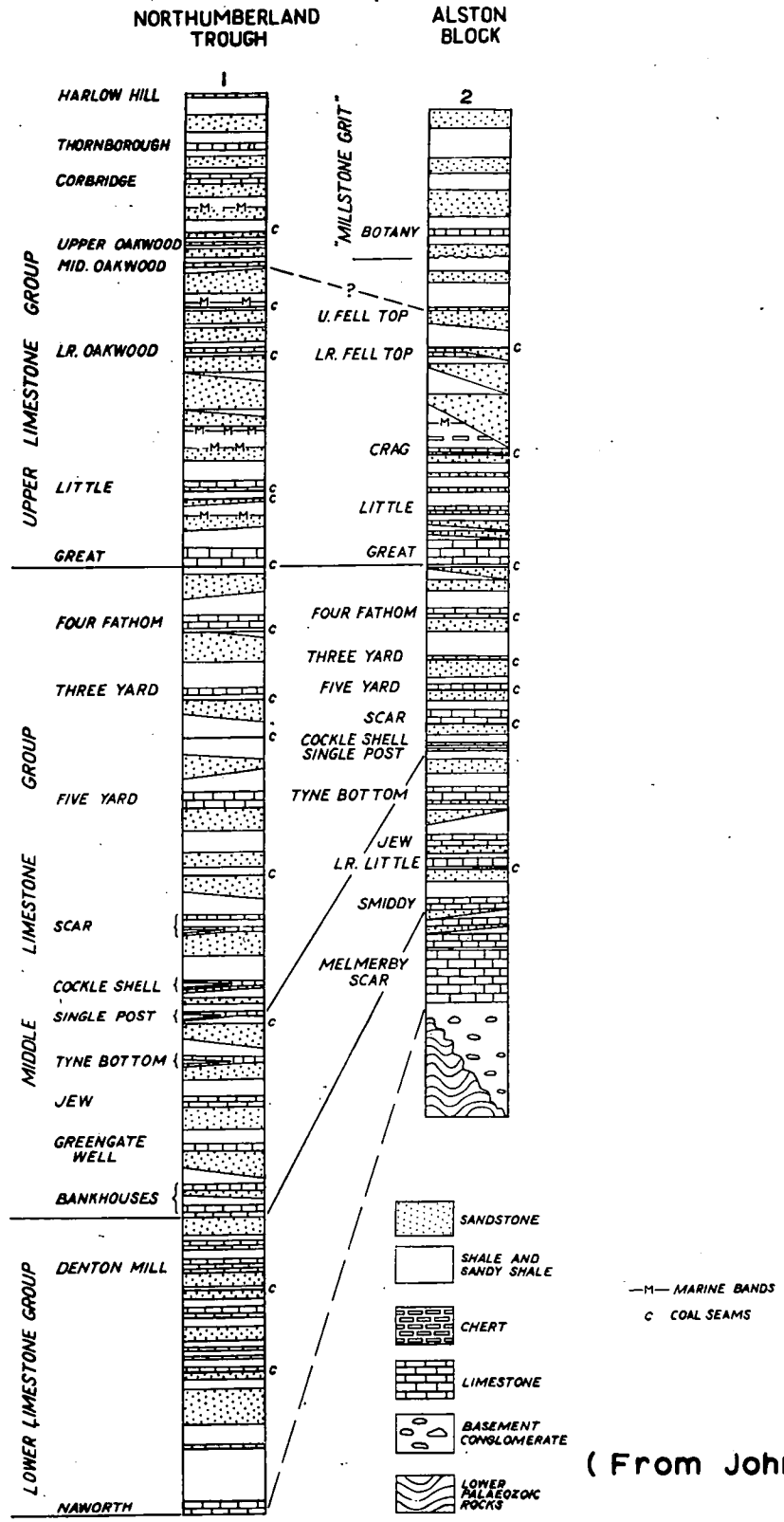
The Lower Palaeozoic rocks from the Cross Fell and Teesdale Inliers are similar to rocks of the same age exposed in the Lake District. In the Cross Fell Inlier the dominant lithologies are slates and phyllites of the Skiddaw Series and lavas and ashes of the Borrowdale Volcanic Series, together with shales and grits. The small inlier of Lower Palaeozoic rocks in Upper Teesdale is poorly exposed. It consists of an eastern belt of soft, greenish and highly cleaved slates and a western area in which exposures of lava occur.

## C. The Carboniferous Succession.

The well known conventional division of the Carboniferous succession into Carboniferous Limestone, Millstone Grit and Coal Measures, derived from an early study of the Carboniferous rocks further south in Lancashire and Yorkshire is inapplicable to northern England. Here, the most meaningful division is between the Lower Carboniferous (Visean), which contains thin limestone beds, together with a few thin and unimportant coal seams, and the Upper Carboniferous (Namurian and Westphalian), with few limestone beds but many productive coal seams. The Millstone Grit of the north of England is best looked upon as a clastic facies developed locally between rocks of Namurian and Westphalian age (Fig. 2.4).

Fig. 2.4

# THE CARBONIFEROUS SUCCESSION



(i) The Lower Carboniferous Rocks.

The Lower Carboniferous or Visean rocks of the Alston Block may be conveniently sub-divided into three groups:-

- a. Middle Limestone Group.
- b. Lower Limestone Group.
- c. Basement Group.

(ia) Middle Limestone Group.

Throughout Middle Limestone Group times rhythmic sedimentation was persistent. Each sedimentation rhythm or cyclothem consists of the following general succession:-

- Coal.
- Ganister or underclay.
- Sandstone.
- Sandy shale, shaley sandstones.
- Unfossiliferous (non-marine ?) ferruginous shales.
- Marine shales.
- Marine limestones.

According to Johnson (1963) the deposition of the limestone at the base of the cyclothem took place under clear, shallow water during a relatively long period of time. The overlying clastic sediments were laid down relatively quickly as a seaward extending delta-front built up sediments to sea-level. The final phase of a cycle was the accumulation of peat under swamp vegetation on low lying coastal flats (Fig. 2.5).

(ib) Lower Limestone Group.

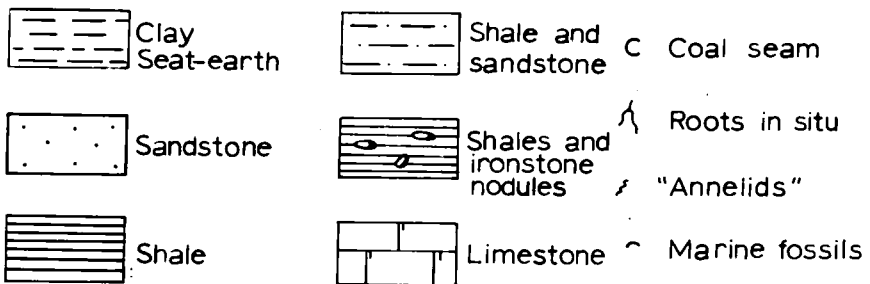
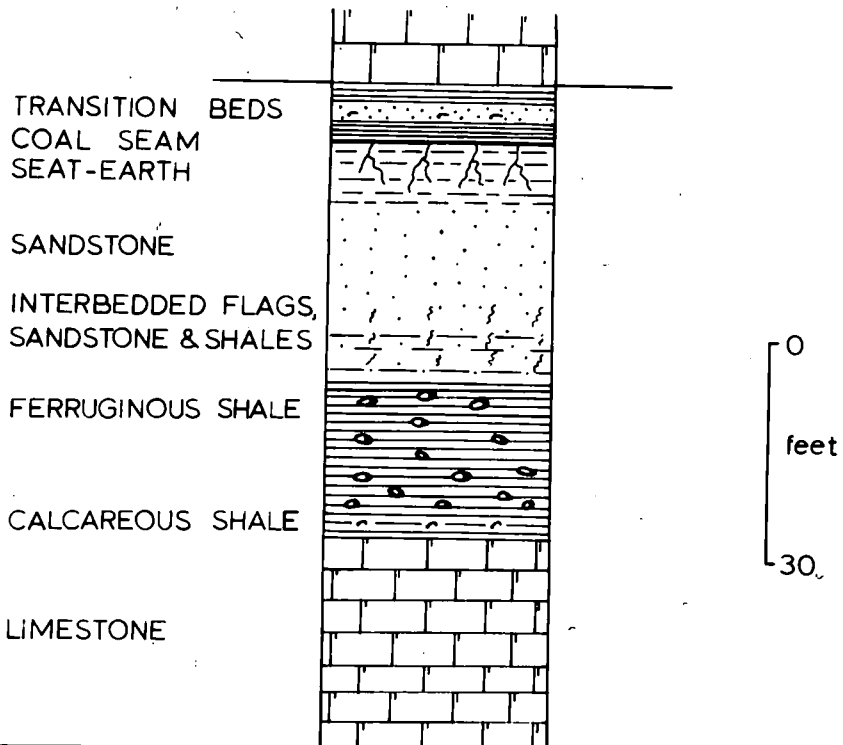
The basal bed of the Lower Limestone Group is the Melmerby Scar Limestone, a massive and fossiliferous horizon. Towards the top of the Lower Limestone Group rhythmic sedimentation spread to the Alston Block.

(ic) Basement Group.

The early history of Lower Carboniferous times in the Alston Block suggests that the area was one of considerable relief. Over the Alston Block the surface relief was gradually obscured by accumulations of conglomerates, sandstones and shales varying in thickness from 140 feet to at least 1,000 feet.

Fig. 2.5

# A YOREDALE CYCLOTHEM



(After Johnson 1963)

The conglomerates, which often contain a high proportion of foreign pebbles such as rhyolite, tuff and granite, are exposed in deep valleys cut into the Pennine escarpment and also around the small inlier at Cronkley in Upper Teesdale.

The basal limestone of each cyclothem is of a grey-blue type, composed of the remains of crinoids, brachiopods, foraminifera and other lime secreting organisms, in a matrix of fine grained crystalline calcite with finely disseminated carbonaceous matter as pigment. Clastic detrital minerals (quartz, mica, etc.) are rare or absent, and even where the limestone rests directly on sandstone there is a sharp break between the two rocks. Division into regular beds on 'posts', a few inches to several feet thick, is general.

The shale is generally black and appears to have a high content of carbonaceous matter. Silt, mainly of angular quartz grains, is rarely absent and may increase to dominating proportions. The sandstone members of the Middle Limestone Group cyclothem are characteristically fine grained, composed of angular quartz grains less than 0.2m. in diameter with flakes of white muscovite or a brown partly leached hydrobiotite. Felspars are relatively uncommon constituents and this coupled with the restricted heavy mineral suites suggests derivation from pre-existing sediments rather than from igneous or metamorphic terrains (Johnson 1963).

#### (ii) The Upper Carboniferous Rocks.

##### a. Upper Limestone Group.

The Upper Limestone Group in the Alston Block is a transitional clastic facies between the limestone facies below and the Coal Measures above; it is almost exactly the equivalent of the original Millstone Grit series of the Askrigg Block defined by Phillips (1836).

This Group commences with the Great Limestone, a thick limestone which outcrops throughout the northern Pennines. The average thickness of the Great Limestone in the Alston Block is c. 60 feet and in its cyclothem character it resembles the limestone of the Middle Limestone Group. Succeeding deposition in the Upper Limestone Group was no longer cyclothem

and deltaic and terrestrial deposition became dominant with thick deposits of shales and sandstones.

b. Coal Measures.

Associated with the Stublick Fault system in the northern part of the block are found small faulted outliers of Lower Coal Measures. These small outcrops are easily traced eastwards into the Durham-Northumberland coalfield. Grey siliceous sandstones, shales and mudstones are the dominant lithologies. Thin coal seams are present but nowhere are they as important as in the succeeding Productive Measures which crop out further east. The areal distribution of these Mesozoic rocks of the Alston Block is indicated in Figure 2.6.

D. Igneous Intrusions.

Two important bodies of igneous material have been intruded into the Carboniferous succession of the Alston Block.

(i) The Whin Sill.

(ii) The Weardale Granite.

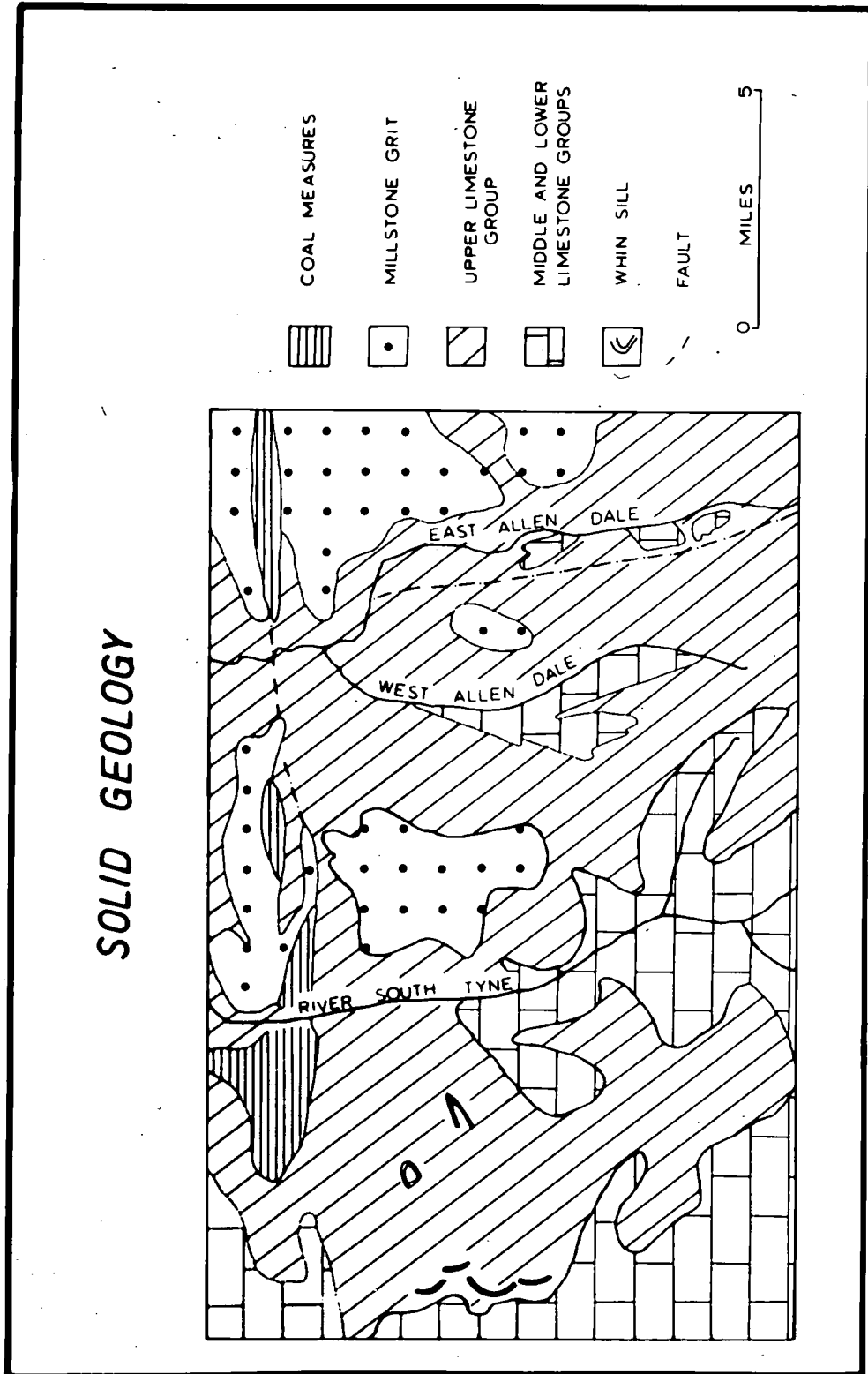
(i) The Whin Sill.

The Whin Sill is a series of connected sills, phacoliths and dykes of quartz dolerite. It is extremely variable in thickness and is transgressive. Major outcrops of the Whin Sill are found in Upper Teesdale and also associated with the Stublick Faults (Fig. 2.2).

It is probably that the Whin Sill was injected during the Hercynian orogeny. Associated with the Hercynian intrusion of the Whin Sill is the extensive mineralisation of the block. Vast quantities of lead, fluorite, zinc and iron ores have been injected into Carboniferous country rock, and much of the nature of the human geography of the region is due to these natural resources so adequately provided by nature.

Confirmation of the Hercynian age of mineralisation is provided by Dodson and Moor bath (1961). Lead isotope measurements give the mean model age of northern Pennine galenas as  $280 \pm 30$  million years, thus confirming their Hercynian age.

Fig. 2.6





(ii) The Weardale Granite.

A borehole at Rookhope, Weardale, proves the existence of a granite emplacement at 1281 feet depth beneath Lower Carboniferous strata. The granite has been dated, using the rubidium-strontium method, at  $362 \pm 6$  million years (Dodson and Moorbath, 1961) corresponding to a Middle or Late Devonian age and is, therefore, not associated with the mineralisation of the area.

No consolidated sediments younger than Carboniferous are found on the western part of the Block. In the east, where the Block's structure has been proved (Bott, 1961) younger Mesozoic formations blanket older structures. Several workers have suggested that younger Mesozoic and Tertiary deposits once covered the whole region and have since been removed by erosion, however, the nature and extent of this cover still lies within the realms of speculation.

Conclusions.

Although the detailed geological nature of the north-west Alston Block is becoming increasingly complex as more and more data are produced it is possible, in general terms, to simplify the overall picture.

A series of Carboniferous sedimentary strata were laid down onto a stable Palaeozoic floor. The whole has been gently upwarped by the intrusion of granite resulting in a gentle tilt of the strata both northwards and westwards away from the Cross Fell region. The erosion, accompanying this tilting has removed much of the cover of younger Carboniferous rocks from the western part of the area. Here, strata of Middle and Lower Limestone Groups are well exposed in the valleys. In the east of the area younger Carboniferous strata becomes more extensive and the river valleys have exposed little of the older Carboniferous sediments.

## Chapter 3.

### HISTORY OF PREVIOUS GLACIAL RESEARCH.

Northern England in general, and the northern part of the Alston Block in particular, is almost 'terra incognita' to the Pleistocene geomorphologist and has never attracted the generations of research workers as have Holderness, the Cheshire Plain and East Anglia.

In the past few geomorphologists have ventured into the northern Pennines for they offer neither exciting glacio-morphological landscapes nor have they yielded organic remains by which glacial events may be dated.

It is important not to view our knowledge of the Pennine Uplands in isolation for they exist in close physical harmony with the surrounding lowlands. A full appreciation of the glacial events and sequences in the adjacent lowlands is of immeasurable help in piecing together the much more fragmentary evidence to be found on the bleak, heather-covered moorland of the northern Pennines.

For this reason the following account, while dealing specifically with the northern part of the Alston Block will also embody much relevant literature dealing with adjacent areas.

Early students of the glaciation of northern England were working at a time when rapid philosophical changes were being made in their subject. It was in that diffuse period of change, from the established diluvial theories of the eighteenth and early nineteenth century development of 'Glacial Theory' with the recognition of the significance of land-based ice-sheets, that the first workers found themselves.

Howse, (1864) was the first worker in northern England to recognise the effect of land-based ice-sheets and the great advantages of 'Glacial Theory' in the explanation of erratic distributions.

Howse (1864) concluded in his paper:

"It is necessary also, in order to account for the carriage of so many large blocks of Mountain-limestone and Millstone-grit, from the higher land, extending from the monoclinial ridge of the Pennine chain

to the coast, to assume an agent, similar to a glacier accumulating in its early course, masses of rock and deposits of mud, derived from the rocky boundary of its channel, and bearing these onwards to the coastline.

The theory of stranded icebergs, and masses of floating ice drifting along the coast-line, is quite insufficient and entirely inadequate to produce the appearances enumerated above, for it is pretty clear that these rocks were glaciated and covered over with a thick deposit of boulder-clay before the land was submerged deep enough for the icebergs to pass over them".

Howse (1864, p.184)

Curry (1867) is the first author to make specific mention of the northern Alston Block. Curry's work is, perhaps, the most useful of the early descriptions of the deposits. In a general survey of the whole area Curry attempted to describe the distribution of 'drift' and also provided brief accounts of the erratic content. Many of the exposures Curry described are no longer available for examination and although much of the description is brief it is a useful addition to an all too scanty literature.

The next ten years were to see the publication of three important papers by one of the early doyens of glacial research in northern England namely, J. G. Goodchild.

In a paper published in 1869 Goodchild put forward suggestions on the nature of ice dissipation which were far in advance of their times.

"Certain is it that after the ice had moved inland and uphill, as I have described, it did not gradually break up into small glaciers and pass in reverse order through the series of changes whereby it obtained its maximum. On the contrary, it seems to have melted quietly away without perceptible movement of any kind".

Goodchild, J.G. (1869, p.282).

Five years later, in 1874, in a paper of great merit, simply entitled "On Drift", Goodchild put forward convincing arguments for the 'Glacial Theory'. In the same paper Goodchild also made reference to differential ice movement, a theme which he was to develop later in his

classic paper on Edenside, and to the depositional environments of glacial deposits. It is in this context that Goodchild made frequent reference to the sub-glacial environment and echoed the later work of R. G. Carruthers.

"When the ice began to melt away, the largest amount of liquefaction would take place at the surface, but terrestrial heat must also have its share in melting the ice at the bottom.

Wherever channels of any kind existed beneath the ice, the water resulting from the liquefaction of the ice would follow the descent of the surface along these channels towards the lowest ground it could find. By this means the stones and mud which were being liberated at the bottom of the ice would be swept away and the channels kept open. On the banks the case would be otherwise. Here, as the mud and stones melted out of the ice, the accompanying water would drain into the lower channels, while the clay and stones would be left behind, and it is easy to conceive how sheets of water sorted materials might occasionally alternate with the unstratified clays in places where a shallow channel had been temporarily formed between the continually rising bottom of the ice and the surface of the sediment, which would be accumulating between it and the underlying rock. The detritus which was being liberated from the surface of the melting ice must also have occasionally found its way down through crevasses or otherwise to be mingled with, or arranged amongst, the more clayey deposits which were being formed beneath".

Goodchild (1874, p.12).

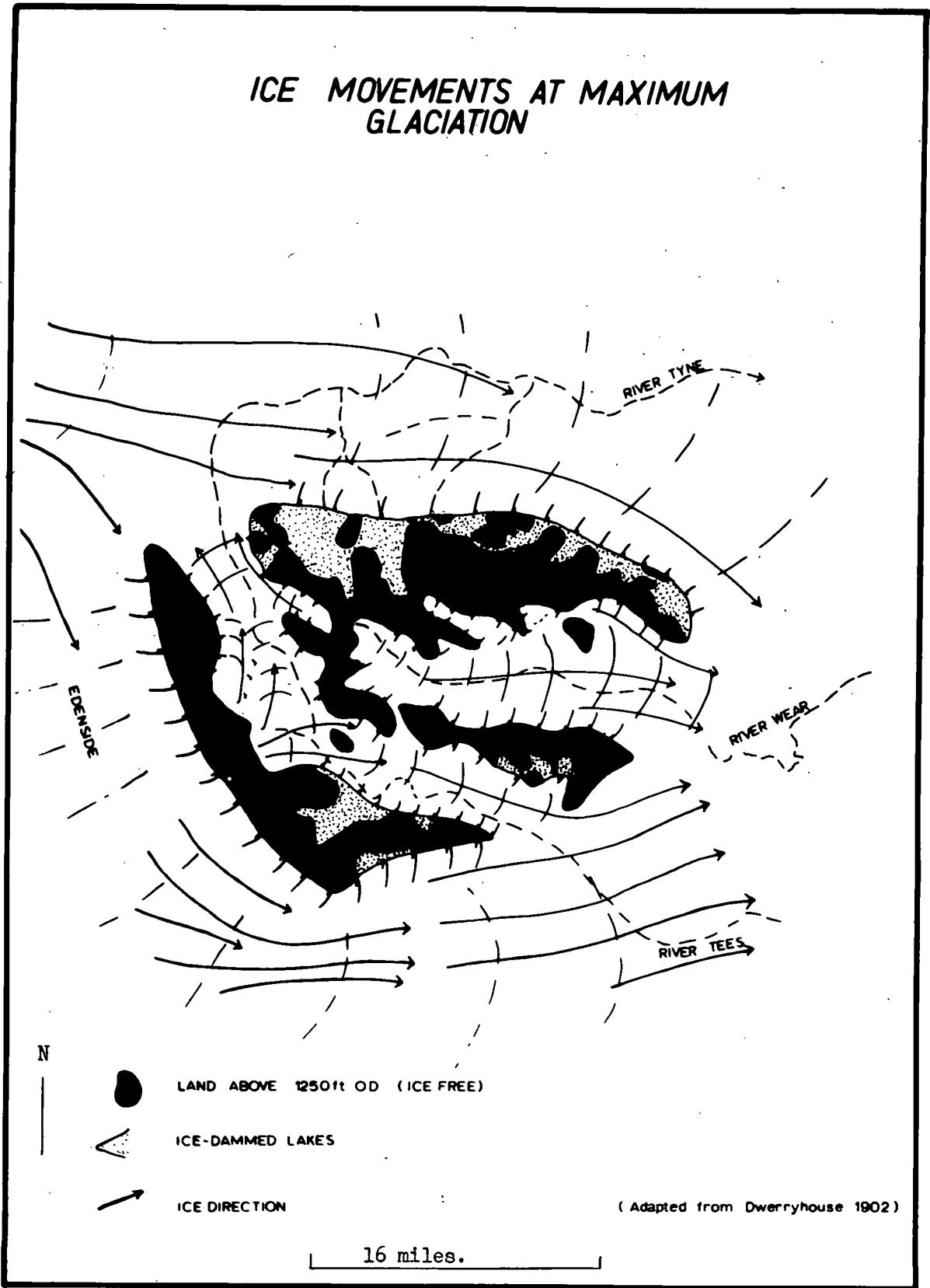
"When at its lowest ebb, the water of the sub-glacial streams would permit the formation of laminated clays in minor tributary channels. The thin sheets of water highly charged with mud would deposit part of their load as a thin film of clay on the surface over which they were flowing, and the long continuance of such action would, in the end, give rise to deposits of great thickness....."

Goodchild (1874, p.13).

Many of the theoretical arguments advanced by Goodchild in the two early papers were put into practice in an elaborate account of the

Fig. 3.1

# ICE MOVEMENTS AT MAXIMUM GLACIATION



glacial phenomena of the Eden Valley (Goodchild, 1875). This study led Goodchild to suggest maximum limits of the ice at 2200-2400 feet O.D. in the south Eden valley with lower limits northwards.

Much of Goodchild's pioneer work went unnoticed and as late as 1891 Bulman still used diluvian arguments to explain the nature of the glacial sands and gravels in Northumberland.

In 1902, A. R. Dwerryhouse, working in the valleys of the Tees, Wear and Tyne, published a paper on their glaciation which was to have a profound influence on later workers.

Dwerryhouse considered that at the period of maximum glaciation ice from Edenside poured through the Tyne Gap deflecting and fusing with a local glacier in the South Tyne Valley (Fig. 3.1). The deflected southern margin of the South Tyne glacier passed across the heads of the West and East Allen Dales and along its southern margin a series of ice-dammed lakes, with a corresponding series of over-flow channels, were produced (Fig. 3.2).

Dwerryhouse argued that at no time was the district completely buried by ice, but that the higher peaks stood out as 'nunatakkr' from the surrounding glaciers. In a consideration of the boulder clay Dwerryhouse distinguished between a local blue boulder clay and a reddish, more gravelly, drift which he considered continuous with the drift in the Eden Valley.

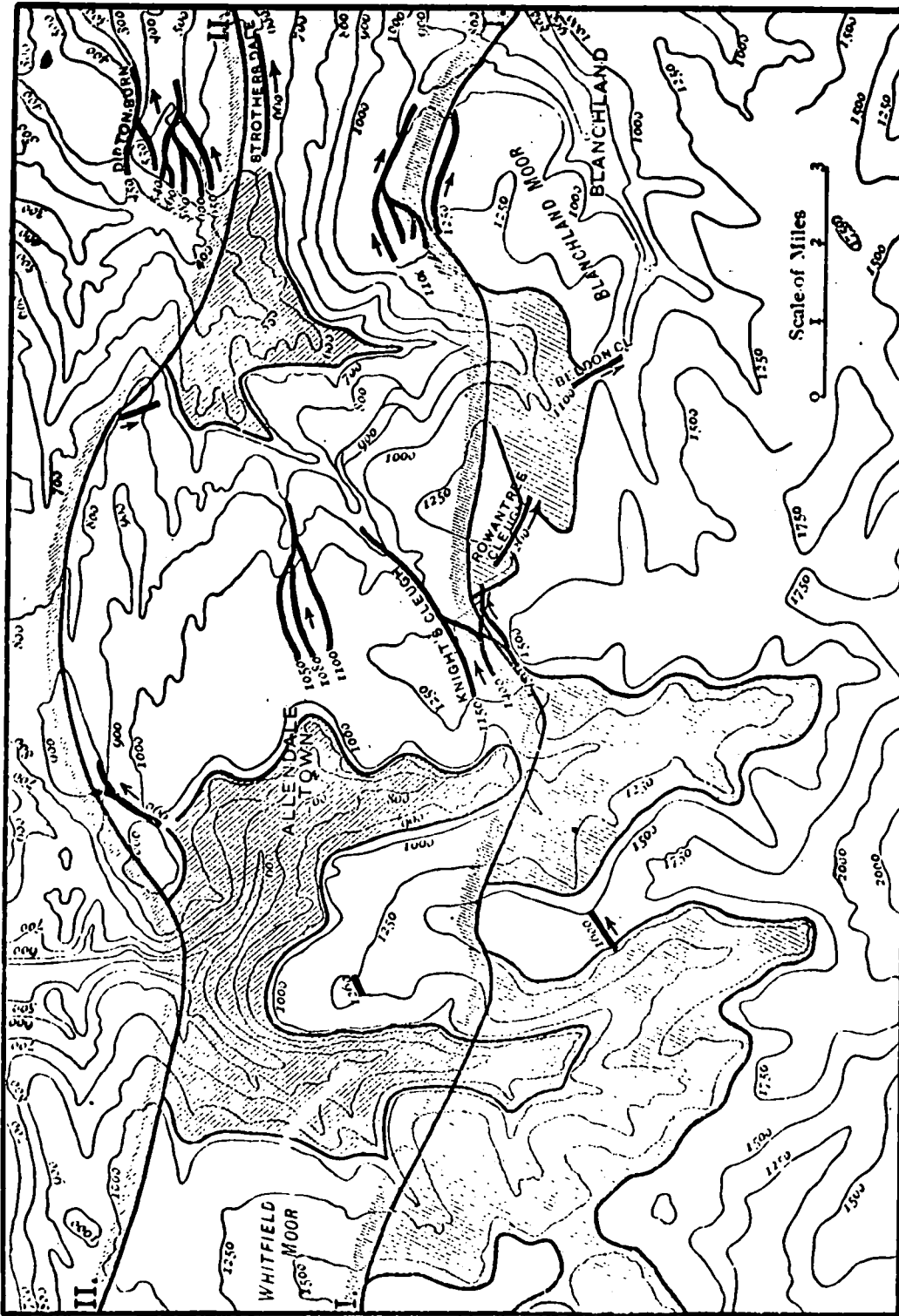
An early description of an interglacial peat deposit on the eastern slopes of Cross Fell by Lewis (1904) has since been re-examined and discredited (Godwin and Clapham, 1951) and the Pennine Uplands have yet to yield organic remains which would help elucidate the glacial chronology and stimulate further research.

An early attempt to quantify the stone content of glacial clay and gravels was the subject of a paper by Herdman (1909), dealing with the glacial phenomena of the Vale of Derwent. Herdman noted that there was a general accumulation of drift on the western side of the Vale and that the lowest member of the glacial succession was a boulder clay which was frequently reddish brown or bluish grey. The boulder clay passed up into gravels and sands. Unfortunately, Herdman does not describe the nature of

Fig. 3.2

(from Derryhouse 1902).

*Glacial lakes of Allendale and Devil's Water.*



Edge of the Ice I. Maximum Glaciation. II. A Period during Retreat.  
Heavy black lines, with arrows, represent overflow-channels.

the relationship between the reddish brown and bluish grey boulder clays and he also fails to describe from which type of boulder clay each stone count has come. Although this lack of clarity does to some extent lessen the merit of the conclusions to be drawn from the paper it is, nevertheless, interesting to note that the gravels of the Vale appear to have a more local suite of rocks than do the boulder clays.

	Ebchester (Boulder Clay)	Ebchester (Gravel)
Yellow sandstone	28%	74%
Grits and Greywacke	28	10
Carboniferous shales	10	
Borrowdale Volcanic	12	6
Granites	2	
Red Sandstone (Triassic ?)	7	
Basalt	2	
Quartz pebbles	2	
Coal	3	
Unrecognised	6	9

from Herdman (1909).

The next twenty years saw the production of little new work concerning the glaciation of the Alston Block. During this time, however, much interest was being shown in the glacial problems of County Durham and in Northumberland north of the Tyne Gap. Much of the information which came to light in a spate of papers between 1910 and 1930 has proved most useful in the establishment of a general regional chronology and pattern of ice movement.

An attempt to establish the Pleistocene succession of Northumberland was made by Smythe (1912). Smythe described two types of boulder clay. The typical boulder clay was a blue grey plastic clay charged with limestone, sandstone and Whin Sill rocks. It occurred over the whole area apart from the Cheviot Massif and was generally the deposit resting on rock-head. A reddish clay with fewer stones was seen to overlies the typical bluish clay and was traceable as far south as the River Wansbeck. From their rock contents it appeared that the lower clay had a western origin, while the overlying red clay came from a more northerly direction.



In explanation of the sequence of the glacial deposits Smythe suggested that at the beginning of the glacial period the hills between the River North Tyne and the Cheviot Massif radiated ice streams in all directions. With the onset of maximum glaciation ice from Edenside became so powerful that it over-rode the local ice and produced a dominant westerly flow. After the maximum glaciation, Cheviot and Tweed valley ice, being deflected south by pressure from the North Sea ice, over-rode much of eastern Northumberland, producing the reddish, upper boulder clay.

In 1920 a raised beach deposit was discovered by Woolacott at Easington, County Durham. It possessed a rich temperate shelly fauna and was considered to have the same origin as the sands and gravels which are exposed for a considerable distance along the Durham coast. The date of origin was considered Late or Post-glacial by Woolacott, although other workers were of the opinion that it was a remnant of an interglacial or interstadial beach.

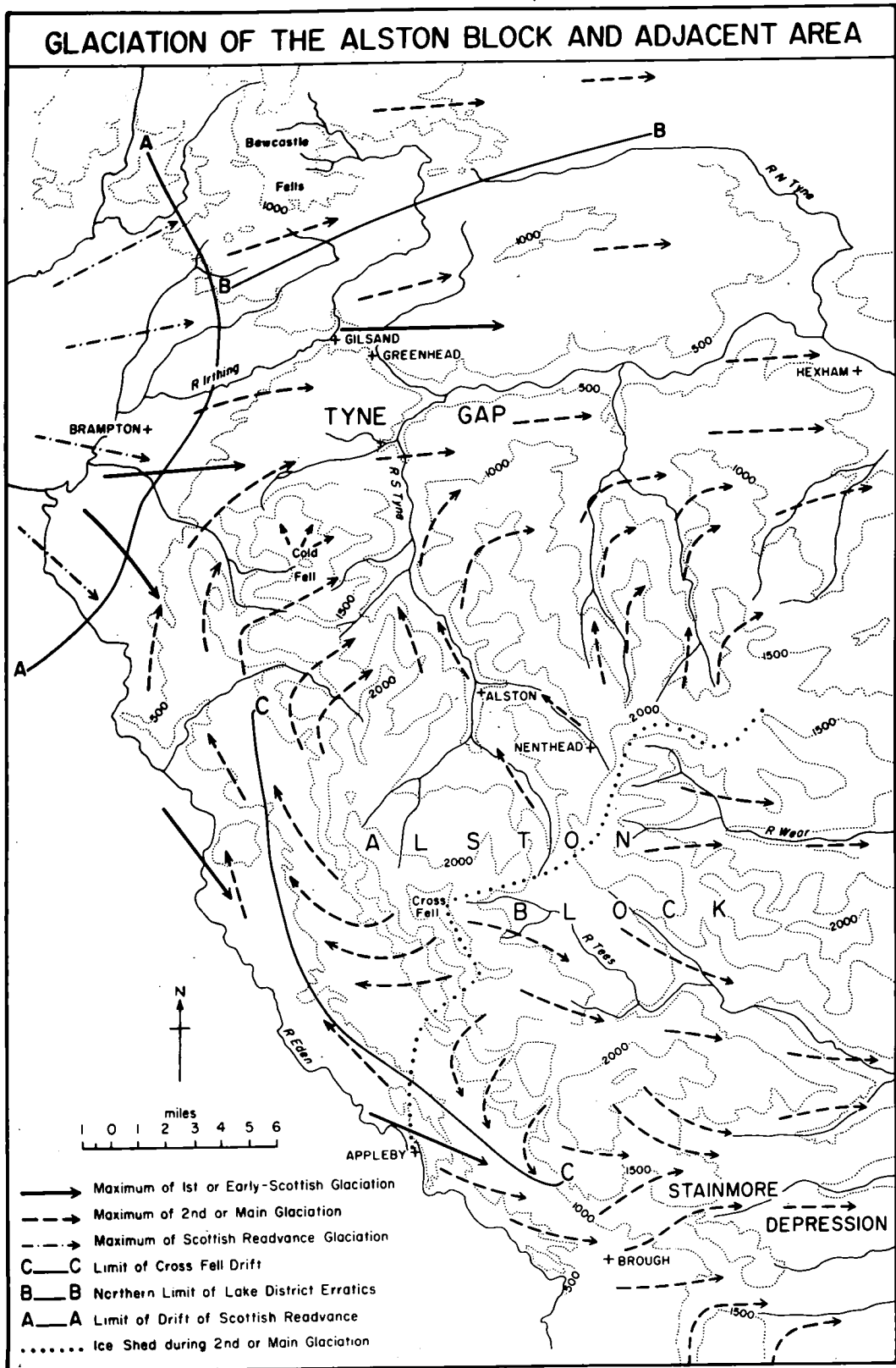
A comprehensive interpretation of the Durham Pleistocene succession was outlined by Woolacott (1921), in which he indicated the existence of four glacial periods separated by intervals of varying importance.

In 1923 Trotter and Hollingworth started re-survey of the Brampton 1-inch geological sheet. Stimulated by the work of Goodchild (1875) both Trotter and Hollingworth became interested in the problems of the superficial geology and their original field areas were soon abandoned and enlarged. For the next five or so years Hollingworth worked in west Edenside and Trotter in east Edenside, the Cross Fell Range and parts of the northern Alston Block.

Trotter's findings were published in a long and detailed paper in 1929. On evidence gained principally in Edenside Trotter suggested the following chronology of events.

The first glacial event to be recognised was an Early Scottish Glaciation. At this period a powerful glacier from Galloway advanced up Edenside, was joined by an ice-stream from the Lake District and swept across the Stainmore Depression. Another branch of the Scottish glacier

Fig. 3.3



( After Trotter 1929a )

filled the Tyne Gap area, and flowed eastward into the drainage system of the Tyne. This glaciation was followed by a considerable interval. The drifts of Edenside indicate that at the maximum of the Main Glaciation, the next glaciation to beset the area, the Vale of Eden was occupied by a combined Lake District and Cross Fell ice-sheet, which escaped by flowing (a) eastwards down the Vale into the Tyne Gap, (b) up the Vale and across the Stainmore Depression and (c) across the northern end of the Pennines up to a height of 2150 feet into the valley of the South Tyne (Fig. 3.3).

In addition to the local glaciers recognised by Derryhouse (1902), Trotter suggested that glaciers were nourished in the Alston Block on Micklæ Fell at the head of Lunedale, and in East and West Allen Dale. The bottom ice of the Alston Block valley glaciers followed a normal course down the valleys, but the general movement of the top ice was eastwards and independent of the direction of the valleys.

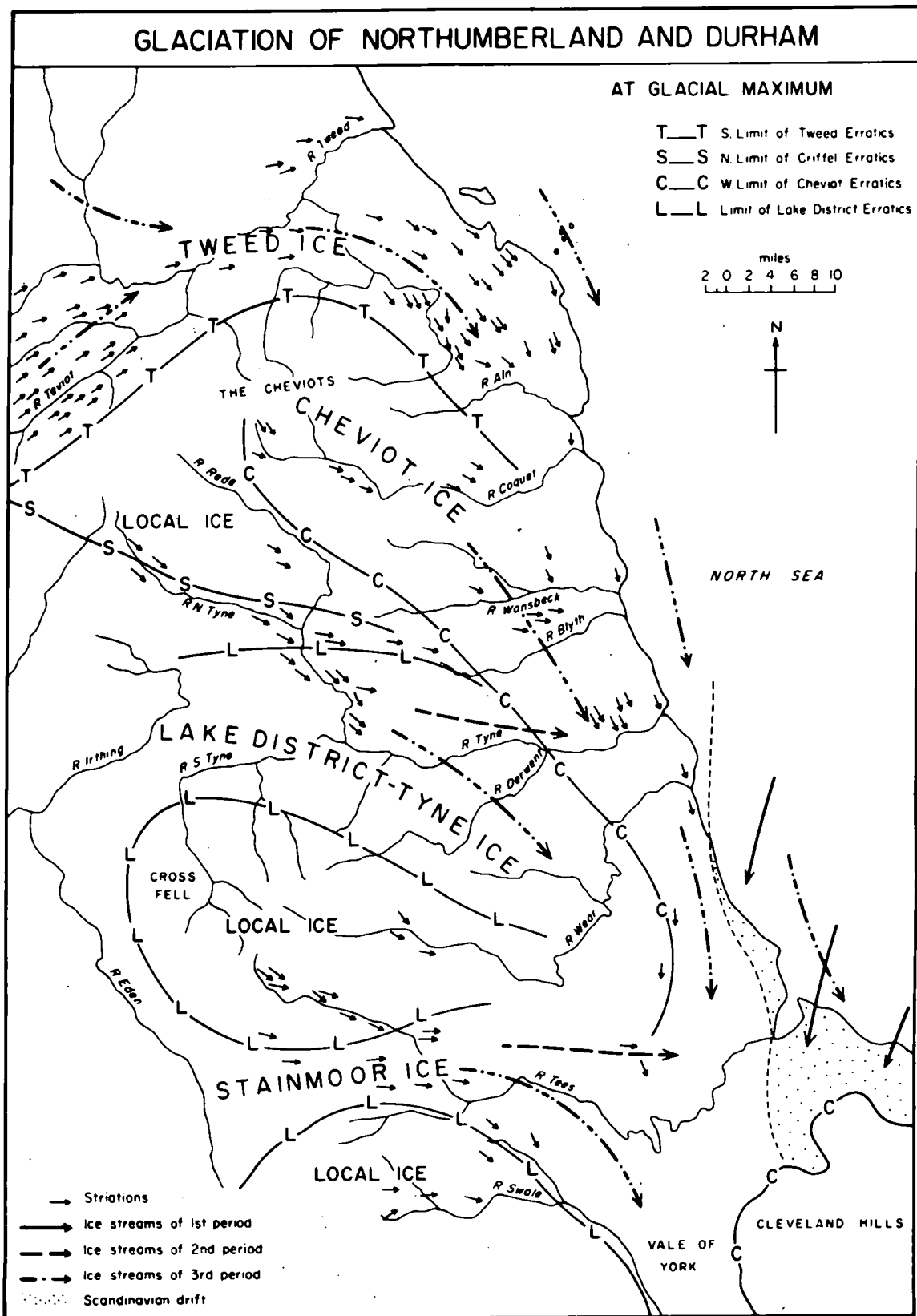
In the retreat stage of glaciation Trotter suggested that the local glaciers severed themselves from the ice flowing through the Tyne Gap and retreated up valley. Glacial lakes developed between the local ice retreating south and active ice blocking their drainage to the north. Unlike Derryhouse, Trotter did not consider that the high level meltwater channels across the divides between the East and West Allen Dale and the South Tyne Valley, drained water from one ice-dammed lake to another, but thought that such channels commenced marginally to the local valley glaciers.

Hollingworth (1931) in a paper on west Edenside confirmed many of the ideas developed by Trotter (1929a). At the maximum of the Main Glaciation Hollingworth suggested an ice gradient in Edenside sloping in a northerly direction towards the Tyne Gap. The ice gradient was such that Cold Fell, at the most northerly end of the Cross Fell Range, was not covered by Edenside ice and would have had its own local ice cap.

Culmination of the work by Trotter and Hollingworth was the publication of a correlation of deposits in northern England (1932) (Table 3.1).

A most comprehensive summary of the glaciation of northern England was presented by Raistrick (1931) as part of a symposium by the Geological Association on the Geology of Northumberland and Durham. In this paper

Fig. 3.4



( After Raistrick 1931.)

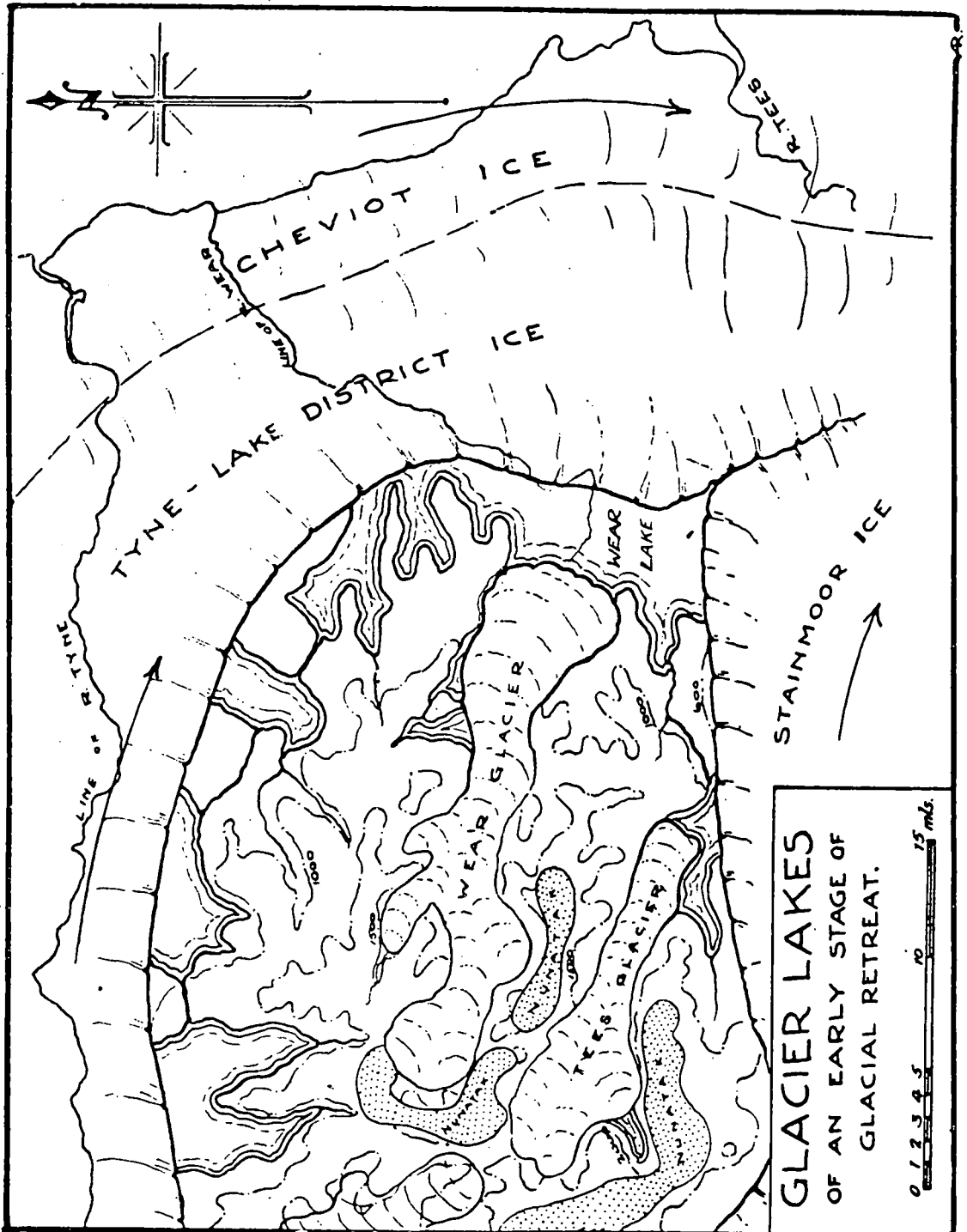
Table 3.1

## CORRELATION OF THE GLACIAL DEPOSITS IN NORTHERN ENGLAND.

(after Trotter and Hollingworth 1932 and Woolacott 1921)

	WEST		EAST	
	Southern Part of the Irish Sea Basin	Lake District and the Solway Firth	Northumberland and Durham	Yorkshire
FIFTH GLACIAL EPISODE		Retreat Phenomena: lakes, channels, sands and gravels, laminated clays.	Not represented	Not represented
		Scottish Readvance Boulder Clay		
FOURTH GLACIAL EPISODE		Retreat Phenomena: lakes, channels, sands and gravels, (Middle Sands of Carlisle)	Retreat Phenomena: lakes, channels, sands and gravels	Retreat Phenomena: lakes, channels, sands and gravels Hessle Clay and its inland
	? Upper Boulder Clay of Liverpool district	Boulder Clay of Lake District, Edenside and North Pennine Maximum	Prismatic Boulder Clay, Cheviot and Scottish Ice with Western Ice in the west	
THIRD GLACIAL EPISODE	Middle sands and gravels	Gravels and laminated clays	Gravels and laminated clays	Gravels etc.
	? Lower Boulder Clay of Liverpool district	Boulder clay of 'Early Scottish Glaciation' (including Lake District, etc.)	Boulder Clay of Western Ice	Purple Upper
SECOND GLACIAL EPISODE			Gravels	Gravels
		? Weathered Boulder Clay of Upper Caldew Valley	Boulder Clay of Scottish and Western Ice	Lower Purple Clay
FIRST GLACIAL EPISODE	Represented Farther south		Loess Scandinavian Clay	Basement (Scandinavian) Clay

Fig. 3.5



( After Raistrick 1932 )

Raistrick discussed the distribution and nature of the boulder clay and on this evidence, together with evidence from striations, he was able to build up a regional picture of events (Fig. 3.4).

A year later Raistrick (1932), in a more detailed paper on the northern Pennines, considered the possible extent of ice-free land in the Pennines during the maximum glaciation, land which botanists believed existed because of the peculiar 'refuge' flora which exists on several of the higher mountains. Raistrick considered that undoubted nunatakk existed in two areas. One area of nunatakk was the summit massif of Cross Fell and Mickle Fell, the other was the watershed area around the head of Weardale.

In a description of the retreat phenomena Raistrick provided much detail about the ice-dammed lake system which ran around the northern and eastern edge of the Pennine Upland. Raistrick envisaged a continuous system of lakes from those occupying East and West Allen Dale to Lake Wear, in County Durham (Fig. 3.5).

Stages in the retreat of the ice sheet occupying the eastern part of the Tyne Gap were described by Anderson (1940). Various stages were indicated by associated marginal meltwater channels and fluvio-glacial deposits.

Nine years later Peel (1949) described the detailed morphology of two large meltwater channels in Northumberland, the Beldon Cleugh and East Dipton Channel. Peel paid attention to the 'up and down' profile which both channels exhibit and considered such a profile to be of sub-aerial origin formed by lakes overflowing in different directions at different times. Later Peel (1956) suggested a possible subglacial origin for the channels.

Sissons (1958a) in a detailed study of meltwater systems in south Northumberland developed the subglacial idea extensively and showed how it could cope with many of the problems raised when the meltwater channels were considered as lake overflows.

One of the most controversial hypotheses to have come from any worker in northern England was the 'Undermelt Hypothesis' of Carruthers (1939, 1947-8, and 1953). The idea that a composite sequence of glacial deposits could be formed by the melting of a single ice-sheet was not

Carruther's own idea, indeed, Goodchild (1874) had hinted at similar processes in connection with glacial deposits in the Eden Valley.

Carruthers thought that the melting of an ice-sheet took place by the process of 'bottom melt', under the pressure of stagnant ice above. Carruthers believed that such bottom melt led to a characteristic sequence of deposits consisting of till, laminated clays, silts and sand. The basal till was regarded as ground moraine. The overlying laminated clays, however, he considered in no way water lain, but rather 'banded dirt' produced by shearing of englacial detritus within the ice and deposited undisturbed by the process of undermelt.

Carruthers explained the presence of more than one till in a sequence as the result of either the shearing up of till from ground moraine, or due to the deposition of a supra-glacial till on top of ground moraine. He considered that all glacial deposits in northern England to be the product of a single glaciation of Saale age.

More recently Maling (1955) in a study of the geomorphology of the Wear Valley concluded from observation in the area of the Middle Wear that there was no evidence for more than one glaciation. Furthermore, Maling suggested that true boulder clay was less extensive than was formerly thought, and that many of the superficial clays of the area were the products of in situ weathering or periglacial erosion.

Since 1954 Smith and Francis of the Geological Survey have re-mapped parts of north-east England and a memoir has been published (1967). Francis, working in the Wear Lowlands, concludes as did Maling (1955), that there was no evidence for more than one glaciation of the area. Smith's interpretation of the Eastern Durham Sequence is as follows:

"Prismatic Clay"	
Morainic Drift	
Upper Boulder Clay	
	Upper Division
Middle Sands	
	Lower Division
Lower Boulder Clay	
Loess	
Scandinavian Drift	



In agreement with Woolacott (1921), Smith regarded the Scandinavian Drift as the oldest deposit within the area. This glaciation was followed by a prolonged period of sub-aerial weathering possibly during the Hoxnian interglacial, during which time the loess accumulated.

The Lower Boulder Clay ice-sheet was thought to have been a major ice-sheet which covered the whole district. From its Pennine and Lake District erratics it is thought to have a westerly origin. Evidence for the dating of this glaciation is not conclusive, but Smith tentatively suggested that it might represent the Saale Glaciation of North Western Europe.

Smith regarded the Middle Sands as being of fluvio-glacial origin. The Lower Middle sands were thought to represent outwash from the Lower Boulder Clay, the Upper Middle Sands being outwash from the Upper Boulder Clay. Smith considered that the Upper and Lower Divisions of the Middle Sands were separated by an interval of considerable duration, possibly the Eemian Interglacial. Smith correlated the raised beach deposit at Easington with this period.

The Upper Boulder Clay was thought by Smith to be a product of the Weichselian Glaciation.

The relevance of Smith's chronology is made clear when it is considered that most workers have correlated the boulder clays of the Northern Pennines with the Lower Boulder Clay of County Durham. On this evidence the boulder clays found in the Pennine valleys are of Saale age.

Conflicting evidence as to the age of the tills in County Durham has recently been found by Catt and Penny working in Holderness. The sequence of tills in Holderness is correlated with the Upper and Lower Boulder Clays of County Durham as follows:-

<u>Holderness</u>	<u>County Durham</u>
Hessle Till	Upper Till
Purple Till	
Drab Till	Lower Till
Basement Till	Scandinavian Till

Mosses embedded in silt are found in small depressions on the Basement Till and are overlain directly by Drab Till. Radio-carbon dating

of the mosses reveals an age of  $18,000 \pm 150$  years B.P. (Catt, personal communication). The overlying sequence of tills must, therefore, be Weichselian in age and, if the correlation with the Durham sequence is correct, and there is no reason for disbelieving it, then the tills of County Durham, and therefore the tills of the northern Pennines, are also of Weichselian age.

Since 1966 a small group of workers led by A. G. Lunn have been examining the deglaciation of the South Tyne valley south of Alston. Although their work is far from complete, mapping of the meltwater channels suggests that there exists a higher, north-easterly draining, set of channels, independent of relief and related to a regional ice gradient, and at lower levels there exists a set of channels controlled very much by topography, and probably formed at a later stage in the deglaciation (personal communication).

For at least ten years part of the South Tyne valley and the East and West Allen valleys have been studied by G. D. Ashley, in connection with the preparation of sheet 19 (Hexham) of the Soil Survey of England and Wales. Neither the memoir nor the soil map has yet been published but interim reports suggest that certain of Ashley's findings are of geomorphological interest.

In a description of the soils on a terrace feature lying c.60 feet above river level in the West Allen Dale, Ashley (1961) remarked:

"It is possible that this feature is related to the 60 feet raised beach, possibly of interglacial age, recognised at Easington on the Durham coast, for the soils are well developed and seemingly as old as anything so far surveyed in the area".

(1961, p.4)

While the present investigator cannot accept Ashley's far reaching conclusions he would suggest that in areas without accurate radio-carbon dates a certain amount of relative chronology might be constructed with the use of modern pedological techniques.

Two important studies of glaciation and glacial deposits have recently been completed in lowland Northumberland and Durham. Beaumont (1967) in a detailed study of the glacial deposits of eastern Durham was able to identify many unique parameters for each of the till sheets he studied. Such quantifiable data proved useful in statistical analyses which he undertook. Searle (1968) studied the tills of the Northumberland coastal plain and has

paid particular attention to the development of soil profiles on different types of till parent material.

Of other geomorphological work at present in progress within the northern Alston Block mention should be made of the studies of E. N. Moore who is elucidating the complex pattern of Post-glacial terrace development in Weardale, of A. Falconer who is studying the glacial sediments of Weardale, and of L. Tufnell who is actively engaged on a study of periglacial processes on Cross Fell.

One of the most exciting discoveries of late within northern England was the exposure of a raft of peat in a road cutting at Hutton Henry, County Durham (Beaumont et al, 1969). Pollen analysis of this peat raft indicated that it is of Ipswichian age.

The Upper Till, in which the peat raft was found is, therefore, of Weichselian age. It must be hoped that organic deposits will soon be found from beneath the Lower Till of County Durham so that the whole sequence may be unequivocally correlated with the tills of Holderness.

---

It will be obvious from the above that we have neither a detailed knowledge of the pattern of glaciation in the northern Alston Block, nor do we have accurate description of the glacial deposits.

Necessarily, much of the early work is in need of revision as rapid advances in knowledge have been made in the past few years. Of particular importance is the application of reliable and objective descriptions of the deposits which allow easy comparison with other areas.

It was with these points in mind that the writer undertook the present project in the South Tyne, East and West Allendale valleys.

## Section 2.

### A DESCRIPTION OF THE GLACIAL SEDIMENTS AND LANDFORMS.

#### Prologue.

The chapters included in this section of the thesis were written in an attempt to build up a total picture of ice movements during the last glaciation of the study area.

Several independent methods of approach have been adopted partly for their own sakes and partly because the writer felt that a more profound conclusion may be made if several complementary lines of evidence were used.

From a study of previous work in the north-west Alston Block it was clear that there were several conflicting ideas on the nature of the glaciation and a great many problems remained unanswered. To familiarize the reader with the broad themes of these problems they are outlined briefly below.

- (a) How extensive was the ice-cover during the last glaciation. Did, for instance, large nunataks exist as supposed by Dwerryhouse (1902) or was the ice-cover more or less complete as suggested by Trotter (1929a)?
- (b) Was the area inundated only by ice from the Vale of Eden and the Carlisle Plain or were valley glaciers also present? Dwerryhouse (1902) indicated that the upper East and West Allen valleys were ice-free during the maximum of the last glaciation while Trotter (1929a) suggested that they harboured local valley glaciers.
- (c) What was the extent of the incursion of ice from the Vale of Eden. Was it more or less restricted to the north of the study area as indicated by Raistrick (1931) or was there a more general incursion as implied by Trotter (1929a)?
- (d) Did any ice-dammed lakes exist at the maximum of the last glaciation as indicated by Dwerryhouse (1902) or were they features of a later period of deglaciation as thought by Trotter (1929a). Did ice-dammed lakes exist at any period of the last glaciation?

## Chapter 4.

### ASPECTS OF THE DISTRIBUTION OF THE GLACIAL DEPOSITS AND ASSOCIATED LANDFORMS

#### Introduction.

The purpose of this chapter is to describe certain aspects of the distribution of the glacial deposits and associated landforms.

It is now conventional to classify glacial deposits generically into those which are essentially unsorted by water and those which are to some extent water sorted. The former are often referred to as till, the latter as fluvioglacial deposits.

For the sake of clarity this classification has been employed in the plan of this chapter. In the first section aspects of the till distribution and landforms are described for each of the major valley and interfluvial areas. In the second section the fluvioglacial deposits are described. Problems arising from this description are mentioned and discussed.

No attempt will be made here to describe the detailed nature of the deposits themselves as this subject is fully discussed in later chapters.

#### SECTION 1. TILL DEPOSITS AND LANDFORMS.

Several earlier workers in the area have described the distribution of the till deposits (Dwerryhouse, 1902; Trotter 1929a and Hollingworth 1931 and 1932).

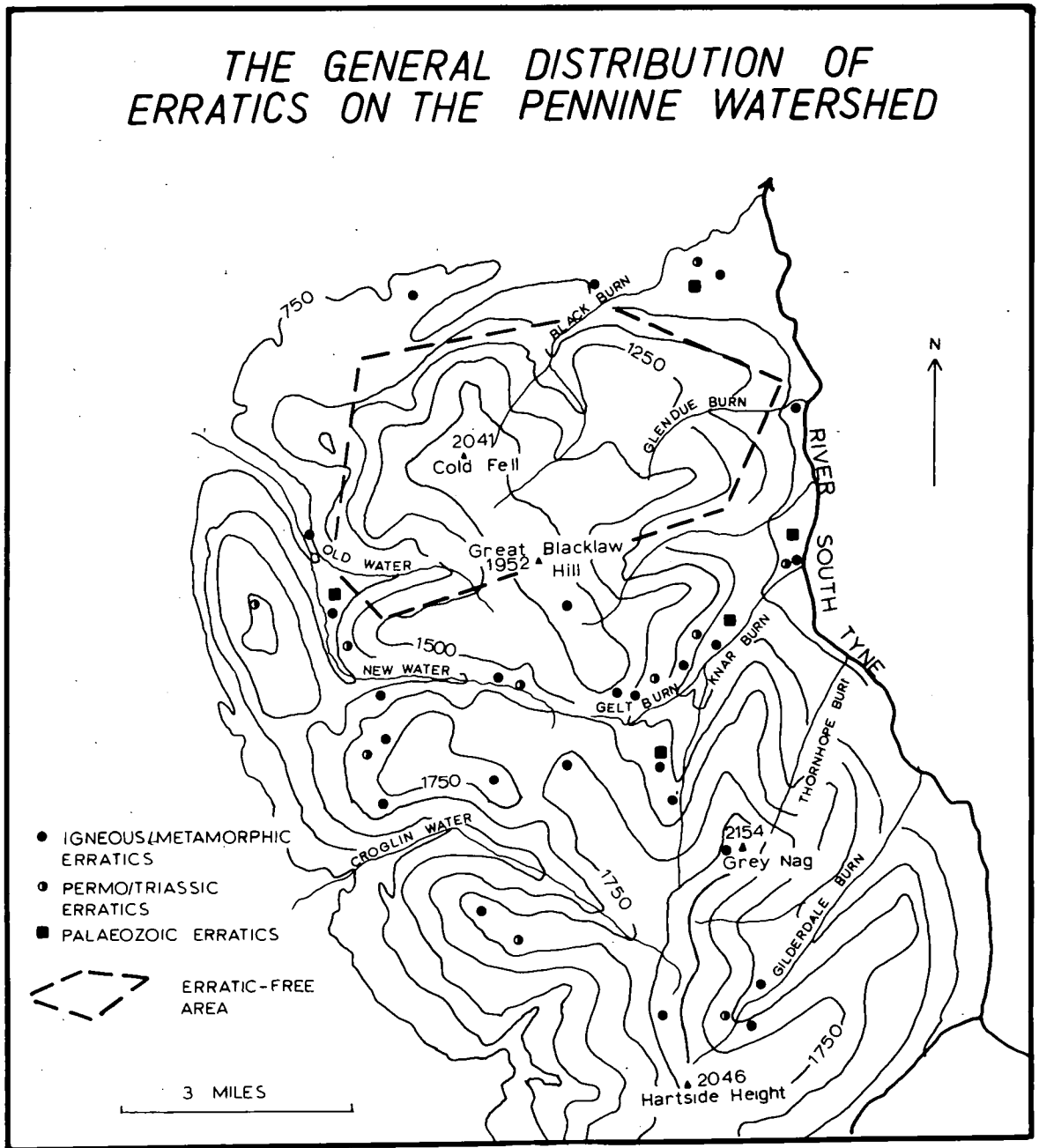
In this section much of the previously recorded information is assessed in the light of the writer's own findings and where necessary alternative answers to the problems of the distribution of till are offered.

##### i. The Distribution of Erratic Material on the Cold Fell-Hartside Height Watershed. (Fig. 4.1).

This problem is dealt with separately because it is concerned not

Fig. 4.1

# THE GENERAL DISTRIBUTION OF ERRATICS ON THE PENNINE WATERSHED



with the distribution of till but with the distribution of erratic material which has been found on this high watershed. The term erratic is here used to define those lithologies which are derived from the Eden Valley, the Lake District and southern Scotland. Considered individually the record of an erratic may not be very important in terms of the pattern of ice movement. If, however, the general distribution of such material is analysed a meaningful picture may be built up.

The distribution of erratic material on the Cold Fell-Hartside Height watershed has previously been mentioned by Trotter (1929a) and Hollingworth (1931, 1932). The general pattern of erratic distribution is indicated in Figure 4.1, which has been compiled from the writer's own findings and from the literature.

It may be seen in Figure 4.1 that erratics are quite liberally spread over the watershed south of Great Blacklaw Hill (1952 feet O.D.). The highest recorded find of erratic material on this part of the Cross Fell-Cold Fell watershed was a small boulder of andesite found by Hollingworth (Hollingworth 1931) at c.2050 feet O.D. on the north-west slopes of Grey Nag (2154 feet O.D.). It is likely that the watershed, if removed of its blanket of peat and moorland vegetation, would reveal many more erratics at such altitudes. There is little doubt in the writer's mind that such erratic material has been left by the last ice advance across the watershed. Without exception the erratic material is seemingly fresh and unweathered. South of Hartside Height, Hollingworth has discovered Edenside erratics up to a height of 2200 feet O.D. (Hollingworth 1931).

Goodchild (1875) considered that at the maximum of the last glaciation the ice in the Eden valley stood somewhere between 2200 to 2400 feet O.D. Hollingworth (1931), basing his conclusions on the distribution of erratic material, confirmed Goodchild's estimate. Such figures probably underestimate the true maximum height of ice which, presumably, would be represented by clean ice, and thus free from erratics.

North of Great Blacklaw Hill no erratic material has been found on the crest of the watershed (Trotter 1929a, Hollingworth 1932). A search by the writer also confirmed that absence of such lithologies from the tills north of this boundary. The moorland north of Great Blacklaw Hill, which

rises gently to Cold Fell (2041 feet O.D.), was considered by Trotter (1929a) and Hollingworth (1931, 1932) not to have been inundated by ice from Edenside and held its own small ice-cap.

ii. South Tyne Valley and its tributaries.

The general pattern of till distribution is indicated in Figure 4.2 which is based on the writer's observations and also on geological maps surveyed by Trotter and Hollingworth and published 1926-27. The thesis area is covered by sheets 102-110 (Northumberland).

Out of the valley sections it is almost impossible to map till deposits which may or may not be exposed beneath the extensive blanket peat or calluna mat.

a. Glendue Burn.

Thick deposits of an entirely local till are exposed at various points in the Glendue Burn up to a height of c.1200 feet O.D. Exposures on the moorland to the north and south of the valley are poor due to the ombrogenous blanket peat. Below 800 feet O.D., in the valley bottom, the tills contain recognisable erratics and at one exposure in the Glendue Wood c.30 feet of such till is exposed.

b. Thinhope Burn.

A tenacious blue-grey till is exposed up to an altitude of 1400 feet O.D. in the main valley. A typical valley bottom exposure is seen in Plate 4.1. Erratic material is, for the most part, absent from the Thinhope Burn although the writer has identified a small Triassic sandstone erratic from an exposure at 1200 feet and Hollingworth (1931) has recorded rare Borrowdale volcanic erratics. The presence of a little erratic material, in an otherwise local till, is entirely in accord with the theory that the watershed south of Great Blacklaw Hill, at the head of the Thinhope Burn, was overridden by ice from the Eden valley.

c. Knar and Gelt Burns.

The most obvious feature about the tills in these valleys is the abundance of erratic material. In the Gelt Burn till is exposed up to 1400 feet O.D. in the valley bottom and numerous small exposures beneath peat



Plate 4.1



Drab-coloured erratic-free till exposed in the Thinhope Burn.

Plate 4.2



Reddish-brown tills exposed in the Geit Burn. View looking down valley towards the River South Tyne.

indicate till to much higher altitudes on the surrounding moorland.

In the Gelt Burn the tills contain a great deal of Permo/Triassic material which gives the till its characteristic reddish colour. (Plate 4.2). The tills of the Knar Burn, above its confluence with the Gelt Burn, are not so red and appear to contain less Permo/Triassic material.

Exposures in both valleys indicate that the tills may be of considerable thickness. Much of the smooth spur between the Gelt and Knar Burns is plastered with till (Plate 4.3). At an exposure at the confluence of the two valleys the till is c.30 feet thick, while an exposure at High Shield in the Knar Burn reveals, c.40 feet of till.

d. Thornhope Burn.

A local till is well exposed in the banks of the Thornhope Burn up to 1250 feet O.D. The lack of erratic material is possibly explained by the fact that the Thornhope Burn is effectively hemmed-in on three sides by a high watershed and it is probable that only relatively clean ice passed into this confined valley.

e. Gilderdale Burn.

Little till has been found out of the immediate valley bottom although here it is exposed up to 1600 feet O.D. The till, which attains a thickness of c.20 feet in some exposures, contains abundant erratics.

f. South Tyne Valley.

At lower levels the South Tyne valley is well covered by till but above 1200 feet O.D. little till has been found on the west facing slopes. South of Slaggyford the drift is almost entirely local in provenance and is frequently seen to contain massive slabs of striated limestone. Below Slaggyford, and the confluence of the South Tyne and the Knar Burn, erratic material is found in the till which still remains, with one or two exceptions, predominantly local in provenance. One such exception is seen at Softley where a small stream has exposed a reddish till which is very rich in erratics. Some twenty yards down stream an entirely local till is seen and it is presumed that two tills, with different provenances, are here in juxtaposition. Hollingworth (1932) has also mentioned red, Lake District, till contained within local till.

Plate 4.3



Erratic-containing till on the spur between the Gelt and Knar Burns. River Gelt is seen on the right of the Plate. View looking west up to the Pennine watershed.

Plate 4.4



View looking down West Allen Dale to illustrate the marked asymmetry of the valley.

Till landforms are not well developed in the South Tyne valley. Three miles north of Alston a small field of drumlins can be seen (Fig. 5.5). The four most southerly drumlins are elongate, the longest being 400 yards long, and show no marked stoss end. The two most northerly of this small group of drumlins, those at Lintley, have a classical shape with well marked stoss ends indicating that the ice source was from the south. It is not known whether these drumlins are composed of till or are in part rock-cored. Smaller drumlinoid features are also seen immediately north of Alston in a belt of moulded drift. Terminal moraine forms are not obvious features in the South Tyne valley. Some 700 yards north of Slaggyford the valley is constricted by a transverse plug of till which rises some thirty feet above the surrounding terrain. It is probable that this feature is a terminal moraine marking a retreat phase of the South Tyne glacier (Fig. 5.3). Outwash gravels are found immediately to the north of this feature.

Ashley (1961) has suggested that the hummocky moraine area immediately north-west of Alston is also a terminal feature.

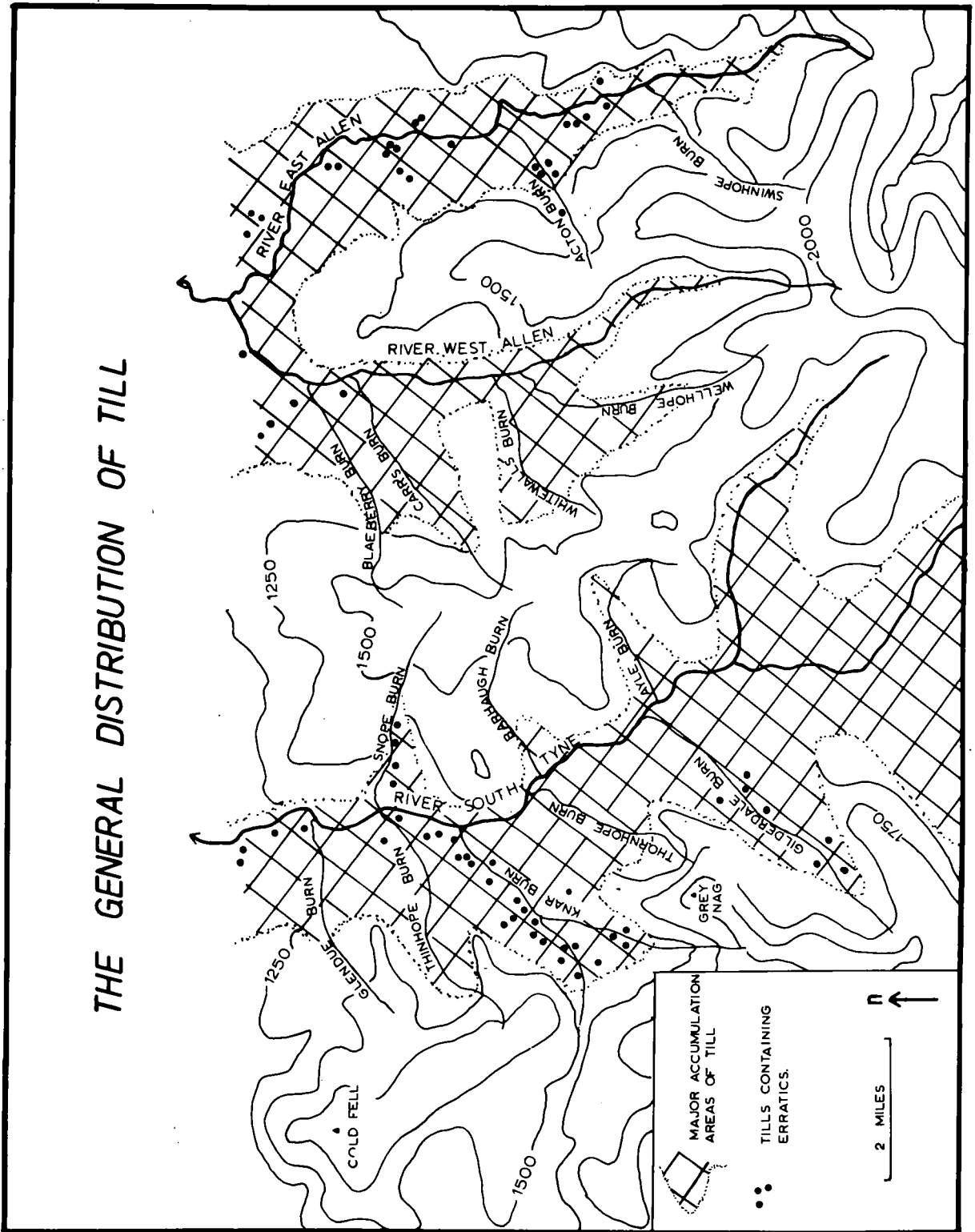
#### g. Snope, Barhaugh and Ayle Burns.

In contrast to their western counterparts, these three eastern tributaries are relatively short, steep and contain little till. The mouth of the Snope Burn is plugged with till which is essentially local in provenance. Further up the Snope Burn erratics become more evident in the many exposures initiated by landslips. In the Barhaugh Burn no till has been found above 600 feet O.D. Below 600 feet O.D. there is a plug of till filling the mouth of the burn in a similar manner to the Snope Burn. No erratic material has been observed in this till.

A local till is found in the Ayle Burn. Unlike the Snope and Barhaugh Burns the till can be traced to within 100 feet of the watershed at 1400 feet O.D. (Fig. 4.2). This fact is significant for other evidence discussed later in this thesis indicates that the col at the head of the Ayle Burn was a major routeway for ice during the glacial maximum.

It has been mentioned that till is not generally found above c.1200 feet O.D. on the west facing slopes of the South Tyne valley. This does not imply that the moorland watershed between the South Tyne and West

Fig. 4.2



Allen Dale valleys was never covered by ice. There is abundant evidence from the finds of erratics to indicate inundation by ice at the glacial maximum. The notable absence of till might be explained by assuming that it has been soliflucted down into the valleys. This does not seem likely in this context as the distances and areas involved are too great. A simpler explanation is that on the high moorlands thin ice streaming over the watershed, was essentially erosive while deposition tended to occur in the valleys where the ice was thicker and more sluggish.

### iii. West Allen Dale.

The general distribution of till in West Allen Dale is indicated in Figure 4.2. In the southern part of the dale an erratic-free till is widespread (Fig. 4.2). It can be found up to c.1600 feet O.D. in the Wellhope Burn and here it may be up to 20 feet thick. Characteristically, much of this local till, like the local till in the South Tyne valley, has abundant striated limestones held in a tenacious matrix.

In the Whitewalls Burn the till is particularly thick, in a few exposures being up to 30 feet. The thickness of the till cover in the Whitewalls Burn may be explained by reference to the nature of the head of the valley, which is a low col (1550 feet O.D.). It has already been indicated that this low col was a major ice-route during the last glaciation and no doubt the thick tills in the Whitewalls Burn are a result of such ice.

Further north in West Allen Dale a predominantly local drift is found in the Carr's Burn and Blaeberry Burn to a height of c.1300 feet O.D. but is mostly absent from the west facing slopes of the valley (Fig. 4.2). North of the gravel spreads at Whitfield the banks of the West Allen river are lined with a heavy till in which erratics, though not abundant are present.

Very little of the moorland above 800 feet O.D. on the west facing slope of the West Allen has any till cover. This east-west asymmetry in the distribution of till also gives rise to a marked asymmetry in the cross profiles of the valley (Chapter 1) and is clearly seen in Plate 4.4.

No drumlins or moraines have been noticed in the West Allen valley.

### iv. East Allen Dale.

The distribution of till is indicated in Figure 4.2. As a general

point it is noticed that while till is found up to 1300 feet O.D. on the east facing slopes nowhere has till been found much above 1000 feet O.D. on the west facing slopes of the dale.

While the general distribution of till in the East Allen Dale is relatively simple, the distribution of local and erratic-containing tills is exceedingly complex. From Allenheads northwards to Sipton the till is entirely local in provenance. Good exposures of this till occur in the banks of the river East Allen at Dirt Pot and also at Sipton Shield. The till exposures at Sipton Shield are particularly interesting. A local till is exposed in the east bank of the East Allen river for about 400 yards north of Sipton. It is not possible to trace this till further downstream due to a thick cover of terrace gravels and it is not known how far north this local till extends. Some 50 yards north of the exposure of the local till and on the opposite bank of the river is an exposure of a till rich in erratics. At one small slip several large cobbles of andesite and granite and one particularly large erratic of Triassic sandstone, nearly 1 foot in diameter, were seen. The stratigraphic relationship between the two types of till is not clear and in no exposure was one type of till seen to overlie the other. It is also worth mentioning that although the two till types were in relatively close lateral proximity the local till appeared uncontaminated by erratics.

Downstream of the Acton Burn the distribution of erratic-containing and erratic-free tills is complex. The general distribution of erratic-containing tills is indicated in Figure 4.2.

At one exposure, on the west bank of the river East Allen one mile north-west of Allendale Town, a red till which much erratic material is seen in juxtaposition to a local till (Plate 4.5). The exact stratigraphic relationship between the two types of till is not definite as the exposure is not entirely clear of slipped material. It would appear, however, that the relationship between the two tills is one of lateral juxtaposition rather than superimposition. Here, as in the site at Sipton mentioned earlier, the local till is uncontaminated with erratics. It is concluded that little mixing of the two tills has occurred.



Plate 4.5.

The west bank of the East Allen River north-west of Allendale Town with erratic-containing till (A) in lateral juxtaposition to erratic-free till (B).



Plate 4.6



Till overlain by terrace gravels exposed in the banks of the River East Allen near its confluence with the River West Allen.

Plate 4.7



Kames at Coanwood in the South Tyne valley showing steep ice-contact faces. View looking towards the south.

Extensive deposits of till are exposed on either bank of the East Allen, particularly north of Allendale Town. For several miles there is no indication of the rock floor of the valley and till is found extensively on the valley floor until the confluence of the East and West Allen rivers (Plate 4.6).

The total thickness of till in the East Allen Dale is not known. Dunham (1948a) mentioned in passing that till fills a buried valley located a little to the west of the present river. Unfortunately no further details are available.

## SECTION 2. FLUVIOGLACIAL DEPOSITS AND LANDFORMS.

Fluvioglacial deposits and their associated landforms are not particularly well developed within the South Tyne and Allendale valleys. The general paucity of the deposits is to some extent reflected by the scant treatment which they have received from previous workers in the area.

Dwerryhouse (1902) referred most tersely to the stratified gravels, sands and clays disposed in plateaux in the East and West Allen Dale and makes no mention at all of the fluvioglacial deposits of that section of the South Tyne valley referred to in this thesis. The only other complete survey of the area, that by Trotter (1929a) also indicated the notable lack of fluvioglacial deposits in the South Tyne and Allendale valleys.

The present description re-examines previously described deposits and also included new information collected during two seasons spent in the field (1967/1968).

For the sake of convenience the deposits of the South Tyne, East and West Allen Dales are described in turn.

### 1. South Tyne Valley.

Fluvioglacial deposits are not widespread in the South Tyne valley. The main accumulations of fluvioglacial material are indicated in Figures 5.3 and 5.4.

Before describing the deposits and the writer's interpretation of their origin it is necessary to summarize Trotter's views (Trotter 1929a)

which are somewhat different from those of the present writer. Trotter suggested that at some stage in deglaciation the South Tyne valley glacier split away from the "Lake District-Galloway Ice-Sheet" which occupied the Tyne Gap and that a glacial lake was impounded between the two. Trotter claimed that the highest level of this lake was 700 feet O.D. He indicated that the gravels of Knarsdale (site 5, Fig. 5.3) were part of a delta built out into the lake at this level. Trotter assumed that the deposits forming this delta were brought down the Knar Burn by meltwater, which on leaving a glacial lake in the New Water spilled through the Butt Hill channel (See Chapter 5). Water from the lake at the 700 feet level drained away via a spillway whose intake was also at 700 feet. From an interpretation of evidence north of the present study area Trotter deduced further lake levels at 650, 600 and 500 feet.

Trotter's interpretation of the fluvioglacial deposits and of the deglaciation of this section of the South Tyne can be criticised on several grounds, the most important of which are enumerated below:

- i. If such a lake existed one would expect to find lacustrine deposits. No mention is made by Trotter of any such deposits.
- ii. The lake envisaged by Trotter would have been quite large and, if present, would presumably have formed marginal erosion and depositional features; no such features are indicated by Trotter.
- iii. Although Trotter was aware of the existence of the fluvioglacial accumulations at Glendue Wood and Know Head (sites 1 and 2, Fig. 5.3) he made no attempt to explain them in terms of his lake sequence.
- iv. An examination of the channel which Trotter thought drained the lake at the 700 feet level revealed that not only does the channel intake at considerably higher than 700 feet (a bench mark indicates the height to be c.740 feet) but the channel also has a multiple head.
- v. The delta (site 5, Fig. 5.3) which Trotter used to establish a lake level at 700 feet O.D. is at no point as high as 700 feet in the field.
- vi. The fluvioglacial accumulations at sites 4 and 5 (Fig. 5.3) are indicated by Trotter as being separate features. In the field the writer failed to find this distinction and suggests that they are one morphological feature.
- vii. If the gravels south of Knarsdale (sites 4 and 5, Fig. 5.3) were brought down the Knar Burn they should contain a high

proportion of erratic material; field evidence would suggest that they are mostly local.

- viii. The writer has suggested in chapter 5 that the Butt Hill channel was not formed as a lake spillway, but was formed subglacially.

In the writer's opinion the origin of the fluvioglacial deposits requires a fresh explanation.

The most northerly of the fluvioglacial deposits examined in the South Tyne valley is that found at Glendue Wood (site 1, Fig. 5.3). Exposures at this site are very limited due to the afforested nature of the terrain. Small, poor exposures in the Glendue Burn and also in the banks of the cutting in the Alston-Haltwistle railway line indicate that the gravels are mostly of local origin. Because of the limited visibility at this site, due to afforestation, it was not easy to gain an overall picture of the morphology of the deposit. However, it is clear that this accumulation of gravel and sand is bounded on its eastern side by a marked break of slope. The steep slopes leading away from the deposit towards the South Tyne are interpreted as being ice contact slopes.

The fluvioglacial deposit at Know Head (site 2, Fig. 5.3) is well defined on its western side by steep slopes, in places up to 25 degrees. It is probable that these steep slopes are the results of slumping in the deposit after supporting ice had melted away (Plate 4.7). An examination of a temporary exposure in the bank of a farm track which crosses this deposit revealed that the material consisted of water-worn gravels and cobbles lying in a matrix of sand and silt; little bedding was observed. Several hundred pebbles and cobbles were examined all of which were local in origin.

Spreads of hummocky gravels are found both north and south of Knarsdale (sites 3, 4 and 5, Fig. 5.3). A careful examination of exposures in these accumulations indicated a local provenance. North of Knarsdale the gravels are exposed in the banks of the Thinhope Burn where they are seen to be set in a silty-clay matrix which is in parts till-like. As at Know Head little sign of bedding was observed.

A small accumulation of fluvioglacial material is also to be seen

in the east bank of the Thornhope Burn north-east of Coldacre Hill (site 6, Fig. 5.3). A particularly well marked ice contact face is developed on the eastern flanks of the accumulation. Morphologically the deposit appears to extend for several hundred yards to the south-east of Coldacre Hill but this must remain conjectural as no exposures are available to confirm this impression.

Restricted spreads of sand and gravel are seen resting on till north-east of Alston town (Fig. 5.5). Surprisingly little fluvioglacial material has been found either at the head of, or leading away from, the meltwater systems located in the South Tyne valley.

The very limited development of fluvioglacial deposits, other than those which must have been at least partly reworked to form present day river terraces, does not permit a detailed account of their formation. The following explanation of their origin must be regarded as interim until more exposures are available.

The deposits at Glendue Wood and Know Head (sites 1 and 2, Fig. 5.3) are interpreted as being kame features formed against the margins of a wasting glacier occupying the South Tyne valley. This would suggest that a local valley glacier occupied the South Tyne valley until quite a late stage in the deglaciation. This view is contrary to Trotter's (Trotter 1929a) who suggested that ice was already clear of this lower section of the South Tyne valley at this stage of deglaciation and that the valley was occupied by an ice-dammed lake.

For reasons already indicated the writer cannot accept Trotter's view on the origins of the fluvioglacial deposits south of Knarsdale (sites 4 and 5, Fig. 5.3). In the writer's opinion, (and also that of Hollingworth, 1932), these deposits were formed on the retreat of the <sup>terminus of the</sup> South Tyne glacier. The fluvioglacial accumulations north-east of Coldacre Hill (site 6, Fig. 5.3) are interpreted by the writer as having formed in a similar manner to the deposits at Know Head. A distinct ice contact face suggests that they accumulated marginally to a glacier in the South Tyne valley.

Shortly before his death, Trotter, in correspondence with the writer, referred to the fluvioglacial deposits cited above as "small outwash

moraines referable to the recessional stages of the South Tyne glacier...." thus confirming the writer's interpretation.

## 2. West Allen Dale.

Very little fluvioglacial material has been found in West Allen Dale. The distribution of known fluvioglacial deposits is shown in Figure 5.8.

Several low mounds of sand and gravel are to be seen in the grounds of the Whitfield Hall estate (site 1, Fig. 5.8). Trotter (1929a) suggested that they represent outwash from a retreating West Allen Dale glacier which had broken away from the Lake District-Galloway Ice sheet and which was retreating up valley. Without better exposures the writer feels unable either to dismiss or confirm Trotter's opinion.

At Bearsbridge (site 2, Fig. 5.8) masses of gravel and sand are bounded by steep ice contact slopes. The material exposed in small landslips, caused by the undercutting of the Dewsgreen Burn, is quite coarse, cobbles up to 4 inches in diameter being common, and sub-rounded. The coarser material is set in a somewhat sticky matrix of silt and sand. This accumulation probably formed marginally to downwasting ice and may be regarded as a kame.

The largest expanse of fluvioglacial material in the West Allen valley is the elongate accumulation found on either side of the Church Burn (site 3, Fig. 5.8). A shallow exposure to the north-east of Dingbell Hill revealed 4 feet of coarse poorly bedded gravel overlain by 1 foot of soil. Many of the cobbles were over 1 foot in diameter. It is interesting to note that these gravels were composed of very few lithologies, a very coarse grit, very similar to millstone grit, being dominant. No erratic material was seen in this exposure.

The lack of good exposures and of a clear morphology considerably hinders a decisive explanation of this deposit. Trotter (1929a) thought that it was an outwash deposit although he does not make it clear whether he regarded it as outwash from the retreating West Allen Dale glacier or from the main ice sheet in the Tyne Gap. The evidence from till fabrics and from stone counts indicates that the last ice to move in this area came

from the west and north-west. The general alignment of the Church Burn deposits normal to this ice direction might suggest that it is outwash from ice retreating northwards into the Tyne Gap.

### 3. East Allen Dale.

The fluvioglacial deposits of East Allen Dale are among the most complex and interesting of those found in the study area. There is no doubt that this short account will serve only as a superficial description of their complexity for the area warrants a series of systematic borings which would bring to light much useful data at present many feet underground. An arbitrary systematic approach is adopted here to avoid confusion.

#### i. Kames.

Several elongate mounds of fluvioglacial material, bounded on one side by a steep ice contact face, are present within the main valley (Fig. 4.3). The most southerly kame is found at an altitude of 1375 feet, one mile west of Spartylea. A small marginal meltwater channel, cut in the backslope of the Kame, breaks through the ice contact slope as it turns down slope, presumably to run under the ice.

Several kames are seen on due west of Studdon at a height of c.1050 feet O.D. A well marked ice contact face, at one locality 25 degrees, is a feature of this group of kames.

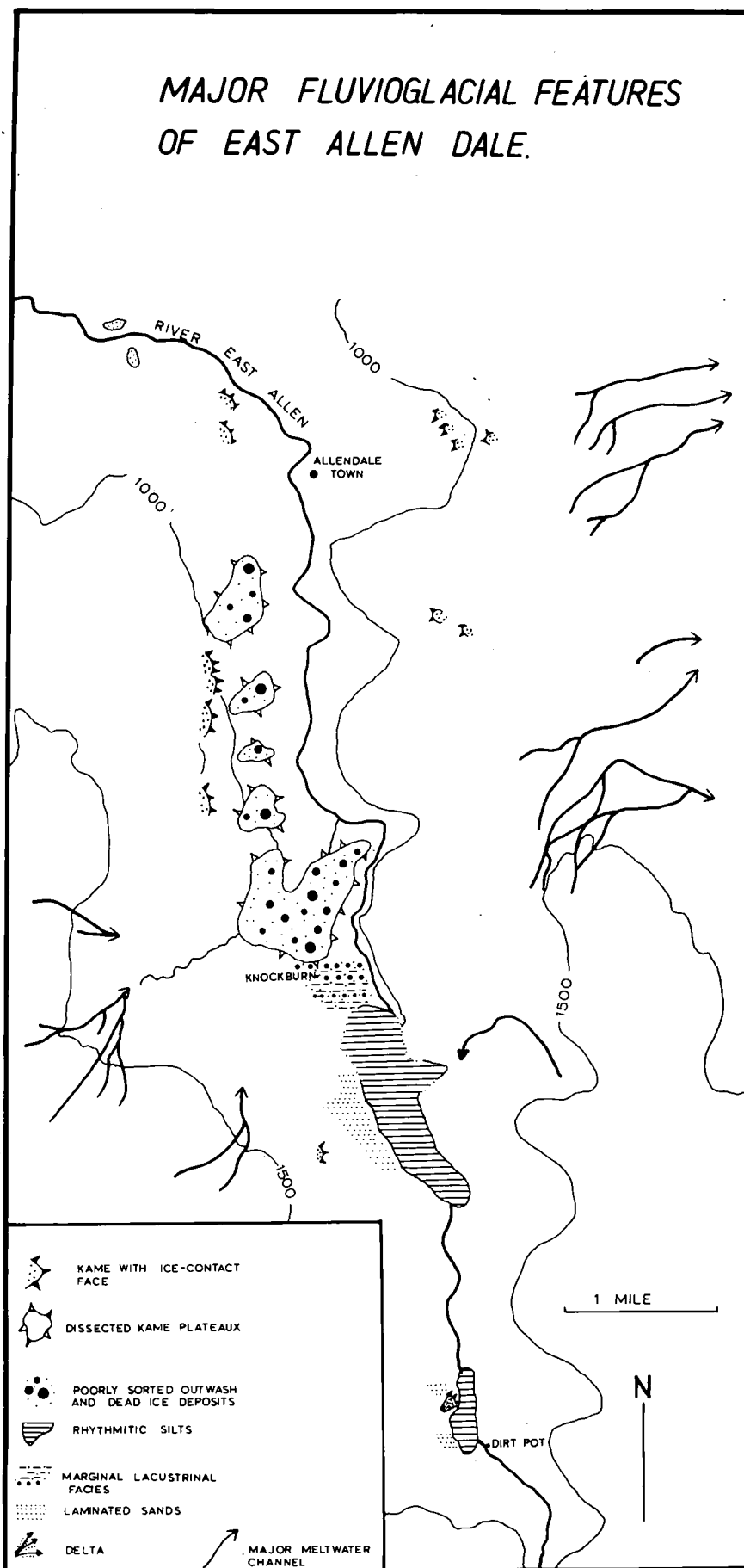
Two kames which appear as small sandy hillocks are also to be seen one mile to the north-east of Studdon at c.1200 feet O.D.; no well marked ice contact face is present in these two examples.

Four kames at 1075, 975, 950 and 925 feet O.D. are found at Bull's Hill, about one mile due east of Allendale Town. This sequence can possibly be taken to indicate phases of downwasting of the ice in this area. The only clear kame features found north of Allendale Town are those found at 775 and 725 feet O.D. at Thornley gate and Riding Hill (Fig. 4.3).

#### ii. Kame Plateau.

This term is used in the sense of Niewiarowski (1963) who has described their most notable feature as being a flat uniform summit surface, the whole being formed by the gentle wasting of stagnant ice.

# MAJOR FLUVIOGLACIAL FEATURES OF EAST ALLEN DALE.





A kame plateau is particularly well developed one mile southwest of Sinderhope (Fig. 4.3). Hereabouts there is a remarkably uniform surface with a slope of less than 2 degrees. It is abruptly terminated to the west by a sharp break of slope where the moorland proper rises away at gradients of 10 to 15 degrees. The deposits forming this landform are seen in various exposures in the Acton Burn which crosses the northern edge of the plateau. In many exposures up to 40 feet of poorly sorted sand and gravel are seen. Little sign of bedding is observed. This was not unexpected because most exposures occur in landslips which are particularly active as a result of undercutting by the Acton Burn. In other exposures very coarse gravels and cobbles are poorly bedded between sands and gravels and till. Hartshorn (1958) has shown that such lenses of till occurring in fluvioglacial material are the results of processes associated with stagnating ice. Hartshorn suggested that lumps of stagnant ice, covered with a layer of till, were surrounded by fluvioglacial deposits. As the ice melts the till on its steepening slopes may move off laterally by flowing onto the surrounding fluvioglacial material. A basal till is seen to underlie the kame deposits.

North of Acton Burn smaller depositional plateaux are also apparent although their area is rapidly being reduced owing to a number of active streams which are eating into the unconsolidated deposits. Nowhere does the deposit attain the thickness it does to the south of the Acton Burn.

### iii. Lacustrinal Deposits.

In the field season of 1968 the writer was fortunate to discover a temporary exposure of a tenaceous, stoneless clay exposed at Sipton Shield in the banks of the River East Allen. Although the exposure was poor, due to active landslipping, the deposits appeared to have distinct laminations with lighter grey layers alternating with darker grey layers. It was evident that this deposit might well be a lacustrine sediment. Detailed laboratory investigations were undertaken and the deposit was shown to be rhythmic in nature, very similar to those laid down in glacial lakes.

Once it had been established that the stoneless sediments at Sipton were lacustrine deposits an attempt was made to try and locate other

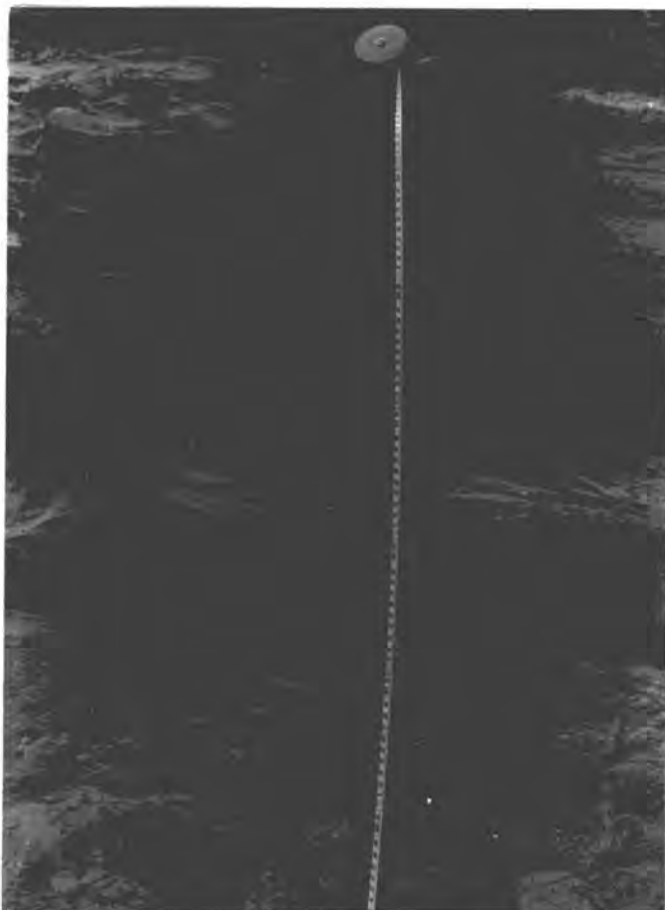
similar deposits and so define the sedimentation basin. A number of other localities were soon found. The most southerly occurrence of rhythmic silt is at Dirt Pot some two miles up stream of the initial discovery at Sipton. The continuity of the deposit over this distance is uncertain. It can be traced with confidence for about a mile up stream of Sipton (Fig. 4.3). No exposure has yet been found between Ellershope Bridge and Dirt Pot; whether this means that there were two separate waterbodies into which silt was deposited is not clear from the available evidence.

Associated sediments, deposited in water, are found both north and south of the lake silts. The deposits at Knockburn are most interesting. They are found to the south of the feature referred to as a kame plateau, and to the north of the rhythmic silts (Fig. 4.3). The nature of these deposits is well seen in a small quarry at Knockburn (Plate 4.8). A typical section consists of the following:-

88 inches	fine sand
82 inches	sand and silt, laminated, laminae showing graded bedding
76 inches	fine sand, little structure
69 inches	distinct laminae of fine sand and silt
65 inches	sand and fine sand, featureless
60 inches	silt, lower half with laminae
56 inches	fine sand
54 inches	sand, structureless
43 inches	coarse sand, current-bedded; fine sand, little structure
40 inches	silt, poorly laminated
37 inches	poorly sorted current bedded sand
0 inches	

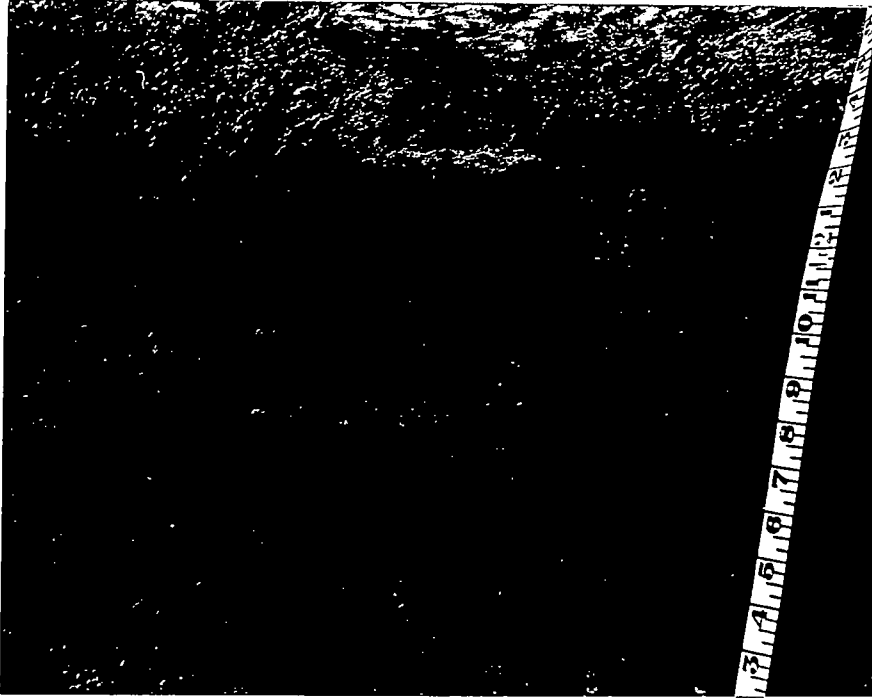
The most striking feature of this deposit are the distinct horizons of laminated silty material, each laminae showing graded bedding. These silty horizons appear to be thrown into irregular undulations which seem to have little meaning in terms of current direction. When traced into the face the undulations, which in places look like mega-ripples, are random in their disposition. Plate 4.9 illustrates the detail of one such laminated silty horizon. At smaller exposures a few hundred yards up stream more

Plate 4.8



An exposure of a marginal lustrinal facies at Knockshield, East Allen Dale. Four siltier horizons are clearly seen to undulate in the form of giant ripples. When traced into the exposure the ripples showed no constant direction.

Plate 4.9



Detailed view of a silty horizon in the Knockshield exposure showing the graded bedding of the siltier laminae.

laminated sand and silt is found and it is noticeable that there is a marked decrease in the amount of coarse sand present.

In a series of small exposures in the Shieldbank Sike a small west bank tributary of the East Allen, laminated silty sand can be traced laterally into the rhythmic silts.

The deposits capping the rhythmic silts are extremely variable both in type and areal extent. At the Knockburn site it has the appearance of a silty, partly washed, till, while further at Shieldbank Sike there are extensive deposits of fine sands with well preserved ripple marks indicating water movement to the south.

One lacustrine deposit which is also seen to have a clear morphological form is a small deltaic formation of sand and fine gravel located c.600 yards north-west of Dirt Pot. Its fairly flat top at 1250 feet O.D. indicates the level of the body of water into which it grew.

From the evidence, admittedly limited from the northern part of East Allen Dale, it would appear that the deglaciation of ice took place mainly by the downwasting. Such downwasting would have been accompanied by a retreat of the ice into the Tyne Gap.

In the upper part of the East Allen Dale the nature of deglaciation was complex. At some stage late in deglaciation the high interfluvium which separates the West and East Allen Dale, would have gradually emerged from beneath a downwasting ice cover. At an even later stage when most of the watershed area surrounding the head of the East Allen Dale had emerged from the ice it is likely that ice would have still been pouring through the low col at the head of the Acton Burn valley. This col would have been able to supply ice from West Allen Dale to the Acton Burn area. It is this extra supply of ice which probably accounts for the extensive development of a kame plateau immediately north-west of the col (Fig. 4.3).

Extensive deposits of sediment were washed away from ice dying in situ. Numerous small faults clearly seen in the exposures of silt and also in the deltaic deposit at Dirt Pot, suggest that much ice was engulfed and eventually buried by such sediments.

A continuous expanse of deep water is not necessary for the deposition of rhythmic silts, and such an expanse is not envisaged here. Rather, it is thought that the silts probably collected in deep pools formed between lumps of decaying ice, the pools becoming larger and coalescing as deglaciation proceeded.

With the acquisition of a drill by the Department of Geography, University of Durham, it was possible, for the first time, to indicate the thickness of the lake deposits. The only site which allowed Landrover access was situated in a field on the west bank of the River East Allen, 100 yards south of Spartylea Bridge and some 30 yards south of an old Tile works, which used to use the deposits some 50 years ago. The nature of the ground was such that there was only time for one boring at this site, the Landrover and trailer, on which the drill was mounted, soon having to be removed to firmer ground. At this locality c.19 feet of rhythmic silts were found resting on till. It is likely that greater thicknesses of silts occur in the area but even so this one site represents one of the thickest deposits yet discovered in Britain. Trotter (1929a) noted some 8 feet of rhythmic clay in the Carlisle district and Clayton and Brown (1958) have recorded up to 19 feet of rhythmic silts and clays near Ware.

---

#### Some Problems - A Consideration.

While the majority of the till deposits may be easily explained either as the result of inundation by ice from Edenside or as the products of local valley glaciers some anomalies remain. One of the most problematic anomalies concerns the distribution of erratics about Cold Fell (Fig. 4.1).

Hollingworth (1931, p.302) stated:-

"The northward movement of ice coupled with the fact that ground higher than Cold Fell was overridden further south suggests that the northward slope of the ice towards the Tyne Gap was an important contributory cause for the failure of Edenside ice to swamp the Cold Fell region".

An approximation of the ice slope inferred by Hollingworth (1931) may be constructed by considering the altitude of those parts of the watershed

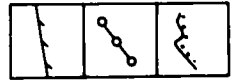
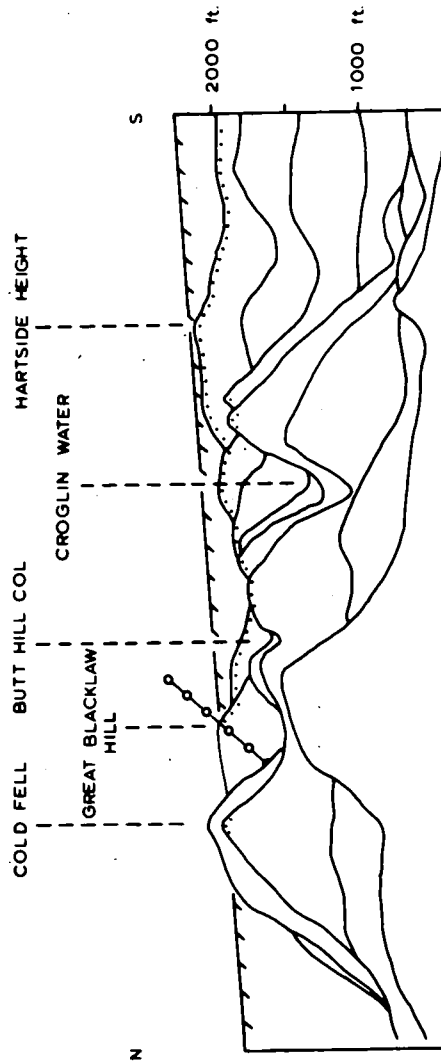
known to have been inundated by ice from Edenside. A reasonably certain axis for the profile lies about Great Blacklaw Hill north of which no erratic material has been found. Naturally, such a reconstruction is very conjectural for we have no indication of the amount of clean ice that passed across the watershed. Nevertheless the profile is substantially the same as that implied by Trotter (1929a) and Hollingworth (1931). Such a profile, drawn across projected relief profiles of the western half of the watershed is illustrated in Figure 4.4. Even if such a profile is grossly in error it is very difficult to explain the distribution of erratics in the Cold Fell area.

Several visits were made by the writer to the New Water, Old Water and Black Burn valleys (Fig. 1.2) in order to locate erratics. As expected erratic material is very common in the New Water and can be traced up to 1500 feet O.D. in the floor of the valley. In striking contrast no erratics have been recorded from the Old Water above 900 feet O.D. and the upper part of the Old Water valley contains only local tills. The juxtaposition of two completely differing tills, as in the New Water and the Old Water, is even more interesting when it is realised that the two valleys are only separated by a relatively low interfluvium. The conjectured ice profile for ice containing erratics (Fig. 4.4) would suggest Edenside ice up to a height of c.1800 feet in the Old Water.

In the Black Burn no erratic material could be found above 750 feet. Such findings are confirmed by Hollingworth (1932). At this locality the ice profile for Edenside Ice suggests that erratics should be found, possibly up to 1700 feet on the northern flanks of Cold Fell. It might be suggested that the conjectural profile indicated in Figure 4.4 is grossly in error, but the writer thinks not. If it were it would take an impossibly steep ice gradient to explain the pattern of erratics in the Cold Fell region. Such a profile is indicated in Figure 4.4. An alternative explanation of the erratic distribution of the Cold Fell area has been proposed by Trotter (1929a) and Hollingworth (1932) both of whom suggested that Cold Fell was covered by its own local ice-cap. It should be noted that it is impossible to argue that Cold Fell was never covered by ice and thus account for the lack of erratic material, as there are local tills well developed in some of the valleys leading up onto Cold Fell. Also the absence of erratic material, which occurs well above 2000 feet a few miles further south, would be

Fig. 4.4

PROJECTED PROFILES OF THE COLD FELL - HARTSIDE  
 HEIGHT INTERFLUVE WITH AN INDICATION OF THE ICE  
 GRADIENT DURING THE GLACIAL MAXIMUM.



Possible Ice Gradient Based On Erratic Distribution

Improbable Gradient (see text)

Erratics Found

1 Miles 5

(vertical exaggeration x 10.56)



difficult to account for.

This somewhat negative evidence would seem to suggest that Cold Fell did, indeed, have its own local ice produced independently of the "mer de glace" in Edenside. The occurrence of this local ice-cap may also be reasoned on climatological grounds.

Manley (1955), produced much valuable evidence with which it is possible to judge whether or not a mountainous area was capable of supporting its own local ice-dome. Manley (1955) has suggested that the lowest limit at which a permanently ice-covered summit might exist is a little above the firn line, or climatic snow line, provided the area is sufficiently extensive. The narrower the summit the greater must be its height above the firn line in order for it to retain an ice-cap.

Manley (1955, p.455) indicated that in a disturbed temperate climate a summit area 1000 metres broad is likely to retain a snowcap and form ice if it rises c.200 metres above the local firn line, while a summit 100 metres broad needs to be 600 to 700 metres above. Generally speaking, the broader the summit area the less it has to be above the firn line to sustain an ice-dome.

The summit area of Cold Fell (measured within 100 feet of the summit - see Manley 1955) is quite broad and has a maximum width of c.1100 metres, and an ice-dome is likely to have formed when the firn line was some 200 metres below the summit, according to Manley's reasoning. Estimates of the firn line at the maximum of glaciation are perhaps a little speculative but nevertheless Manley (personal communication) has indicated to the writer the firn line about Cold Fell during the maximum of glaciation was probably around 1500 feet, or a little less. More definite comparisons with the Lake District, where Manley has accumulated quite a lot of evidence on local firn limits, are not possible until accurate data for the precipitation on the high Pennine moorlands are available.

Assuming then, that Manley's suggestion is of the right order it appears that Cold Fell could have accumulated a local ice-dome.

If the notion of a Cold Fell ice-dome is correct it must be accepted that Cross Fell, some 900 feet higher (2930 feet O.D.) and probably much wetter (data are not available for detailed comparisons) must have

accumulated a considerable ice-dome on its summit, which would have been well above the local firm line during the maximum of the last glaciation. This would confirm the writer's evidence that Cross Fell and the surrounding high moorlands were an important source of ice dispersal during the last glaciation.

#### Conclusions.

Although till and fluvioglacial landforms are not well developed within the north-west Alston Block this short description has shown that the overall pattern of deposits and associated landforms provided useful evidence as to the nature of ice dispersal and dissipation.

The lack of well developed landforms is probably a reflection of the glacial environment operative during the last glaciation rather than any Post-glacial processes which might have removed such features.

## Chapter 5.

### MELT-WATER CHANNELS.

#### Introduction.

Three studies of glacial drainage in the northern Pennines, namely those of Derryhouse (1902), Peel (1949) and Sissons (1958a), will undoubtedly remain as important pieces of geomorphological literature. In one way, these three researchers represent a whole cycle of geomorphological thought.

The development of ideas on the glacial drainage system of the north-west Alston Block can be traced back to Derryhouse (1902) whose "classic" interpretations of the meltwater features as glacial lake spillways was further advanced by Trotter (1929a) and Raistrick (1932). Such a mode of thought, which was particularly advocated by Kendall (1902) in the North Yorkshire Moors, prevailed for more than half a century in the interpretations of such features by British geomorphologists, and is echoed of late in the writings of Embleton (1956), Twidale (1956) and Straw (1957).

The initial stimulus, in Great Britain, for a re-interpretation of many meltwater systems was provided in a paper by Peel (1949) who drew attention to two meltwater channels in southern Northumberland whose floors possess an up-and-down long profile (Plate 5.1). Later, in 1956, Peel suggested that such channels were formed, in part at least, subglacially. Such a mode of origin for similar channels in Scandinavia had been advocated more than a decade before by Mannerfelt (1945).

Sissons (1958a) was, perhaps, the first to attempt a re-appraisal armed with this relatively new concept and he chose a sequence of channels in southern Northumberland to test the concept of subglacial meltwater. Such was the success of Sisson's interpretation, overcoming many difficulties attached to the previously held concept of lake spillways, that it triggered-off a spate of similar re-appraisals (Price 1960, Derbyshire 1961, Embleton 1961 and 1964, Bowen and Gregory 1965).

A. Types of glacial meltwater channels.

1. Proglacial drainage channels.

Such channels draw water away from ice or ice-bordered lakes. Prior to the notion that channels could be formed subglacially most glacial drainage channels were interpreted in this way (Dwerryhouse 1902; Kendall 1902).

2. Marginal and Sub-marginal channels.

The surface of a glacier, where it abuts against a hillslope, is often gently convex owing to the increased melting of the ice at the margin. Meltwater may collect in this marginal hollow and where there is a longitudinal gradient the meltwater will drain along the margin as long as there are no fissures in the ice. In time such drainage may carve a marginal channel. If the ice fissures before the development of a true channel form then a narrow shelf may be left. Because of the ease with which the marginal ice becomes fissured such marginal channels are easily drained. Marginal channels are characteristically small, short, comparatively straight and run along the hillside making only a small angle with contours. Often they may be small arcuate features or in-and-out channels, formed by a stream emerging from the ice, impinging on solid rock and then flowing back into the ice.

Sub-marginal channels, formed under the ice, but near its lateral edge, (Von Engel n 1911) are probably more common than true marginal channels (Sissons 1961). It is only with great difficulty that it is possible to distinguish between a marginal and a sub-marginal channel. In some instances a sub-marginal rather than a marginal origin is suggested by the gradients of the channels. Where hillside channels of varying gradients occur in juxtaposition their relationships may show that, even if the more gently inclined ones are of marginal origin, the more steeply inclined channels certainly cannot be (Sissons 1961).

Marginal channels of present-day glaciers have been described by Tarr (1897, 1908, 1909), Von Engel n (1911) and Russell (1893). All three make it clear that simple marginal drainage is not as common as sometimes

supposed. Indeed Von Engel (1911) suggested that sub-marginal drainage is more typical than truly marginal drainage in most wet-based valley glaciers.

### 3. Subglacial Channels.

As long ago as 1893, Russell deduced that the drainage of the Malaspina Glacier is essentially englacial and subglacial. Unfortunately such early observations went unnoticed and it is only within the last two decades or so that the concept of subglacial drainage has been applied to deglaciated areas. Several types of subglacial meltwater channels are recognised.

#### i. Subglacial Chutes.

The term subglacial chute was used by Mannerfelt (1945) for those channels cut by meltwaters plunging directly down a hillslope beneath ice. Often subglacial chutes connect with marginal or submarginal channels whose meltwaters, after flowing along a hillside, suddenly abandoned that course for one more directly related to the bedrock slope. It seems likely that the openings and location of many chutes are related to the development of crevasses in the ice. The height range of chutes is usually no more than 300 feet, supporting the theory of crevasse control (Derbyshire 1961).

Chutes may be distinguished from Post-glacial gullies by their relations to other meltwater channels, their abrupt beginnings and endings, the absence of alluvial fans from their lower ends and the fact that they are often now dry (Sissons 1961, King and Embleton 1968).

#### ii. Up-and-Down Channels.

Such features, with the now familiar 'humped' long profile, remain the strongest evidence suggesting a subglacial origin for many meltwater channels. Although some workers have tried to explain the peculiar long profile of such channels in terms of reversal of meltwater flow, Post-glacial erosion at one end of the channels and by the erosion of channels across a col previously formed by a stream flowing in the reverse direction, such explanations have generally proven unsatisfactory (Sissons 1961).

Peel (1956) suggested that such up-and-down channels may be partly subglacial in origin but found the possibility of subglacial meltwater eroding

up hill under hydrostatic pressure very problematic.

Sissons (1961) put forward three points favouring a subglacial mode of origin. Firstly, many channels with an up-and-down erosional long profile are continuous features throughout their lengths, strongly suggesting that they were formed by streams of meltwater flowing in a single direction. Since streams cannot flow uphill except under hydrostatic pressure it would seem that the channels could have been cut only by sub-glacial streams.

Secondly, Sissons (1961) pointed out that many up-and-down channels are much larger than the nearby marginal and sub-marginal channels. Such size contrasts suggest that these large up-and-down channels were excavated independently of the marginal and sub-marginal channels by large volumes of water flowing beneath the ice.

Thirdly, some up-and-down channels are so related to other channels and fluvioglacial deposits as to strongly suggest a subglacial origin.

Price (1960) suggested a modification of the subglacial mode of formation of up-and-down channels. Price considered that such features might be formed by the superimposition of englacial streams on an area of varied relief during the last period of downwasting. This hypothesis avoids the necessity for postulating meltwater flowing subglacially beneath great thicknesses of ice.

### iii. Col Channels.

Such features were first mentioned by Mannerfelt (1945) who named them 'Sadelskaror' or col gullies. Mannerfelt suggested that such gullies were initiated by a subglacial stream forced through the col by hydrostatic pressure.

Derbyshire (1961) in a study of subglacial col gullies in the Cheviots confirmed Mannerfelt's suggestion concerning the mode of origin of such features. Derbyshire (1961) indicated that the complete absence of many true deltas, bottom deposits or old beach lines adjacent to the col gullies strongly suggested that the lake overflow theory of origin for such features is no longer tenable. As additional evidence Derbyshire (1961) cited the frequently reversed gradients within such channels and the presence of glacial till in the channel bottoms.

Several authors have remarked how the largest channels are consistently located in pre-existing cols (Sissons 1960b, Clapperton 1966). Such cols, being lower than the surrounding terrain, are able to relieve the hydrostatic pressure of meltwater which may have drained a large area of subglacial drainage flowing in the direction of thinner ice and therefore less pressure (Sissons 1960b). As less energy is required to force subglacial water through the relatively lower col channels they become dominant relief systems of meltwater drainage.

The manner in which large meltwater streams become subglacial is debatable for observations are difficult. Perhaps the most widely accepted theory is that of superimposition, first mentioned by Common (1957) and elaborated by Price (1960).

Price (1960) suggested that large meltwater streams existed on and in the ice. As the ice downwasted these streams were lowered and eventually came into contact with bedrock and thus superimposed their courses.

#### B. The significance of Meltwater Channels.

A study of meltwater channels in an area often provides a clear picture of the phases of deglaciation (Gjessing 1960). In particular if true marginal channels can be recognised it may be possible to reconstruct ice margins and gradients of the ice-sheet (Sissons 1958b).

Marginal channels are not the only indication of the nature of the surface of the ice. Subglacial river systems are often directed by variations in ice pressure and by the regional slope of the ice.

Derbyshire (1961) has described the simple physical case of such ice directed drainage. During the summer, Derbyshire suggested that the temperature of the upper part of the ice is at, or above, melting point. It is within this zone that the englacial meltwater moves. Below this permeable zone, which is probably not more than 300 or 400 feet thick lies compact ice with no seasonal fluctuations in temperature.

The interface between these two zones of ice Derbyshire has termed the 'plane of summer melting'. Derbyshire (1961) suggested that on the basis of recent observational evidence in areas of live ice, that the absolute

altitude of the plane of summer melting decreases outwards from the area of greatest ice thickness. This situation, he suggested, creates an inclined plane which controls the direction of subglacial waters on a regional scale.

It is known from hydrostatics that the pressure,  $P_i$ , exerted on an ice-tunnel roof is a product of the ice thickness,  $t$ , and its density,  $d_i$ .

$$P_i = t \cdot d_i.$$

Now, if  $P_w$ , which is a vertical force exerted by water in an enclosed

$$P_w = (h - \frac{1}{2}v^2/g) dw$$

where,  $dw$  is the density of water

$v$  is the velocity

$g$  is the acceleration due to gravity.

tunnel, is greater than  $P_i$  there will be a tendency for the ice to be lifted and the drainage, which had previously been confined in the channel, will spread out. Gjessing (1960) has suggested such a phenomenon in his study of deglacial phases in Atnedalen.

It is at the point, therefore, where  $t$  (the ice thickness) and hence  $P_i$ , becomes small, that confined subglacial drainage will end. Subglacial drainage may, therefore, be conveniently divided into three zones (Fig. 5.1).

- a. An entry zone, which may be a valley side or a crevasse system,
- b. A subglacial zone, where meltwater is confined by a relatively thick layer of ice and flows under considerable pressure.
- c. A distal zone where the ice may thin enough for the confined meltwater systems to lift the ice and spread as a sheet (Gjessing 1960).

Meltwater channels can also suggest the conditions of the ice during deglaciation (Embleton and King 1968). Large marginal drainage channels are most typical of active and advancing glaciers; sub-marginal drainage is often associated with active but stable ice, while subglacial drainage is more characteristic of stagnant ice of the thinner zones of active glaciers.

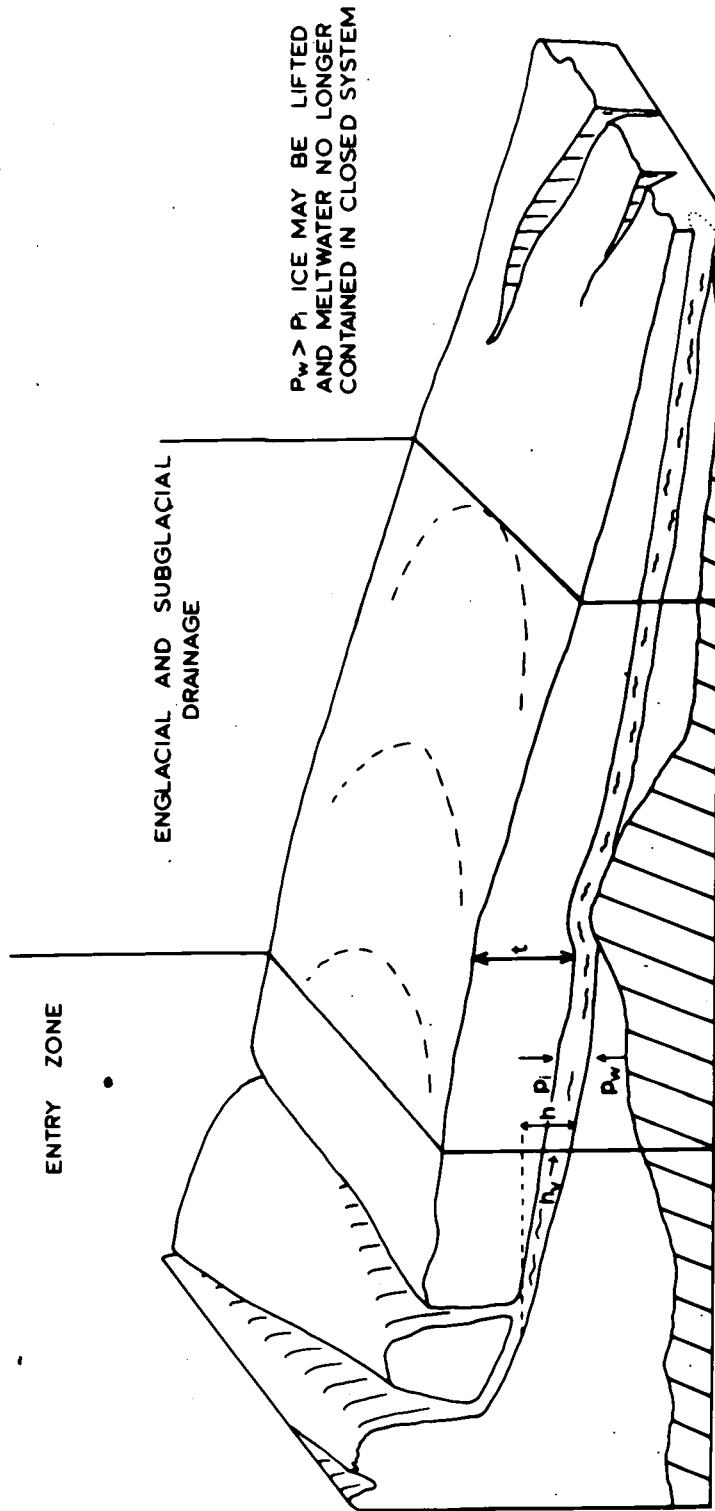
### C. The Meltwater Channels of the South Tyne and Allendale Valleys.

The meltwater channels described in this chapter were mapped on the 1:25,000 scale as part of a systematic coverage of the study area carried during the 1966-67 and 1967-68 field seasons. A great majority of the channels



Fig. 5.1

# A SIMPLE MODEL OF POSSIBLE MELTWATER ENVIRONMENTS



described in the following account have not been previously mentioned in the all too scanty literature on the region.

No attempt was made to level, or measure with any great degree of accuracy, the meltwater features. A great many channels contained considerable depths of peat and it was not possible for the writer to initiate a programme of borings; indeed the physical difficulties of carrying the necessary equipment across several miles of moorland was not an encouraging thought.

Although several spectacular channels exist, the area does not abound in meltwater features as compared with the Cheviots or the North Yorkshire Moors. Many of the valley-side slopes may have been too steep for marginal or sub-marginal drainage to have been supported by ice. It is also likely that the Yoredale strata, with their tendency to form ledges and benches, may have supported marginal drainage but the writer found it difficult to determine the exact origin of such bench features. Some may have been etched out by differential ice erosion, others may have been formed by marginal meltwater action, still others could have formed Post-glacially. Because of this <sup>UNCERTAINTY</sup> ~~problem~~ only those marginal features with a reasonably defined channel form are considered in this account.

1. South Tyne Valley.

a. The Butt Hill Col Channel.

The Butt Hill channel (Fig. 5.2, Plate 5.2) is one of the most spectacular in the study area and may be regarded as a classic example of a col channel. On either side of the channel, which has gorge-like proportions, the slope rises gently to c.1900 feet O.D. The channel itself is some 700 yards long and 350 feet wide at its maximum. The proportions of the channel are very much underestimated in Plate 5.2 as the floor of the channel is covered with much peat and pools of growing sphagna.

Trotter (1929a) regarded the Butt Hill channel as being a simple lake spillway. At an early stage of deglaciation he envisaged a small lake held up by ice at the head of the New Water, on the Edenside side of the Cold Fell-Cross Fell watershed. This lake spilled over the broad col down the Gelt Burn into the South Tyne valley.

Fig. 5.2

BUTT HILL COL CHANNEL

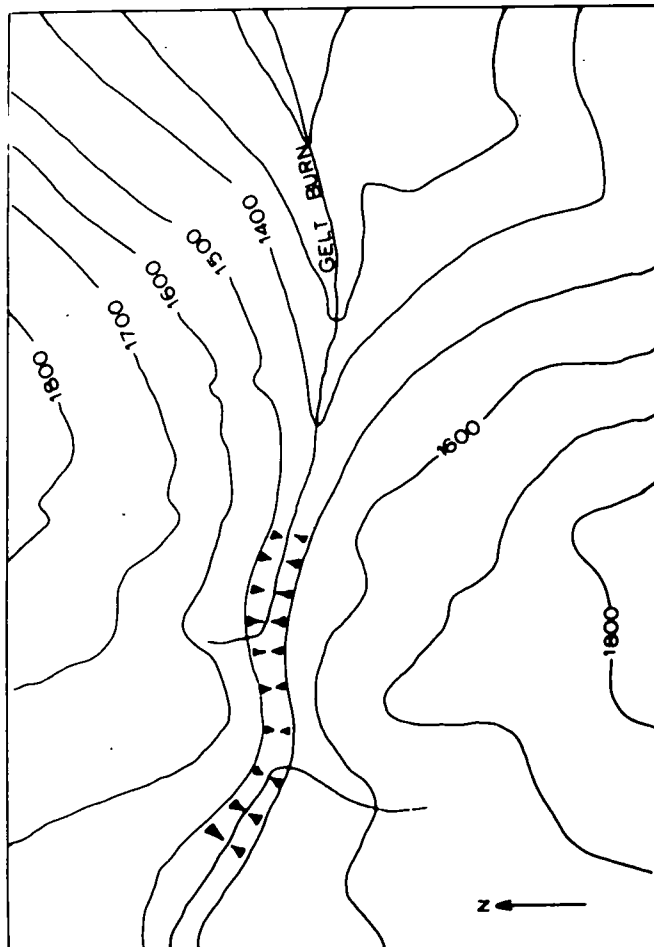


Plate 5.1



Aerial view of the Beldon Clough looking towards the east.

Plate 5.2



The Butt Hill Col Channel.

It is not possible to accept this hypothesis on several grounds. Firstly, it seems most unlikely that the small lake envisaged by Trotter (1929a) could have cut such a large rock-cut channel. If this were the case then it would also be expected that the Gelt Burn, which now drains away from the channel to the South Tyne valley, would be accordant with and have the same dimensions as the channel: this is not the case. The Gelt Burn, within one hundred yards of the exit of the channel, occupies a small, youthful valley, most unlike the Butt Hill channel.

Secondly, the writer and Hollingworth (1932) have recorded boulder clay beneath the peat within the entrance of the channel. In the writer's opinion there seems no reason, therefore, to accept a lake spillway mode of formation. An examination of the watershed for several miles to the north and south of the Butt Hill channels reveals that it lies in the only major col. It is not possible to indicate the role of ice erosion in broadening this col but it is known that ice from the Lake District and Scotland poured over this col. It seems most likely therefore that the Butt Hill channel is a typical subglacial col channel indicating that the general regional ice slope was from the Eden Valley towards the east and the South Tyne valley.

b. Meltwater channels north of Slaggyford.

Surprisingly few channels have been identified in this section of the South Tyne Valley (Fig. 5.3). Two small channels are seen on the hill-side east of Slaggyford. Channel a (Fig. 5.3) is a small in-and-out channel some twenty feet wide and five feet deep. It was probably formed marginally to the ice occupying the South Tyne valley at a height of c.1400 feet O.D. A few hundred yards to the north and intaking at a similar height there is a well marked marginal channel (channel b, Fig. 5.3). After a short marginal course the channel turns abruptly down hill in the manner of a chute (Plates 5.3 and 5.4). Both channels a and b (Fig. 5.3) were formed marginally to a glacier which occupied the South Tyne valley at an early stage in the deglaciation.

Channels c and d (Fig. 5.3) are broad and shallow and cut in thick drift. Their position in the valley bottom suggests that they might have acted as channels for water issuing from the terminus of the retreating South

Fig. 5.3

# MELT-WATER CHANNELS NORTH OF SLAGGYFORD

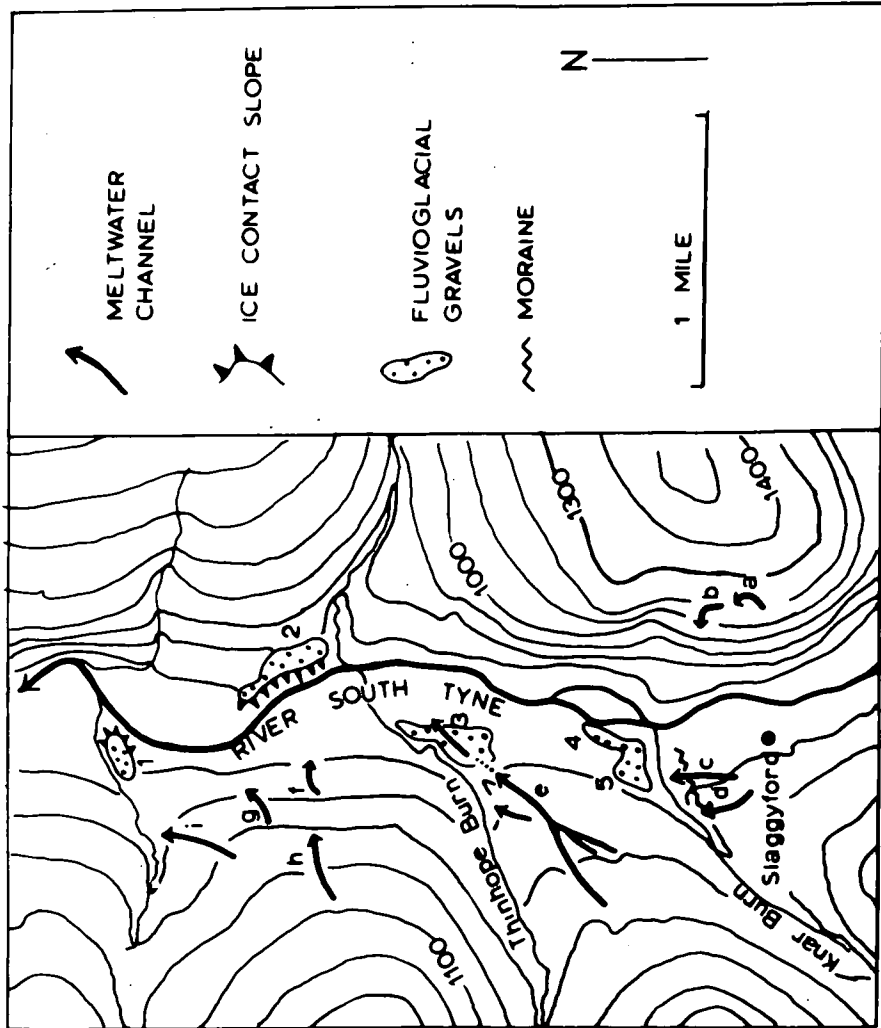


Plate 5.3



View looking down the upper part of channel b (Fig. 5.3)

Plate 5.4



View looking up into the exit of channel b (Fig. 5.3)

Tyne glacier.

Channel e (Fig. 5.3) which has a multiple intake, is some 100 yards long and 30 feet deep and begins most abruptly. Its general alignment with the Knar Burn suggests that this channel may well have been formed subglacially under ice which found its way through the Butt Hill channel and down the Knar Burn. In the field, channel e (Fig. 5.3) can be traced in a north-easterly direction across hummocky gravels found north of Knarsdale. A careful inspection of the gravels failed to reveal any erratic material, and it is likely that they were formed on the retreat of the local glacier occupying the South Tyne valley. If this is so then a tongue of diffluent ice must have still occupied the Knar Burn because its meltwaters have cut across these local gravels.

Only four channels have been found north of Knarsdale (channels, f, g, h and i Fig. 5.3). Channels f, g and h are chute-like. All three channels begin abruptly and run down the maximum slope. Channel i is 30 feet wide and some 600 yards long and has a shallow northerly gradient indicating the slope of the ice to the north.

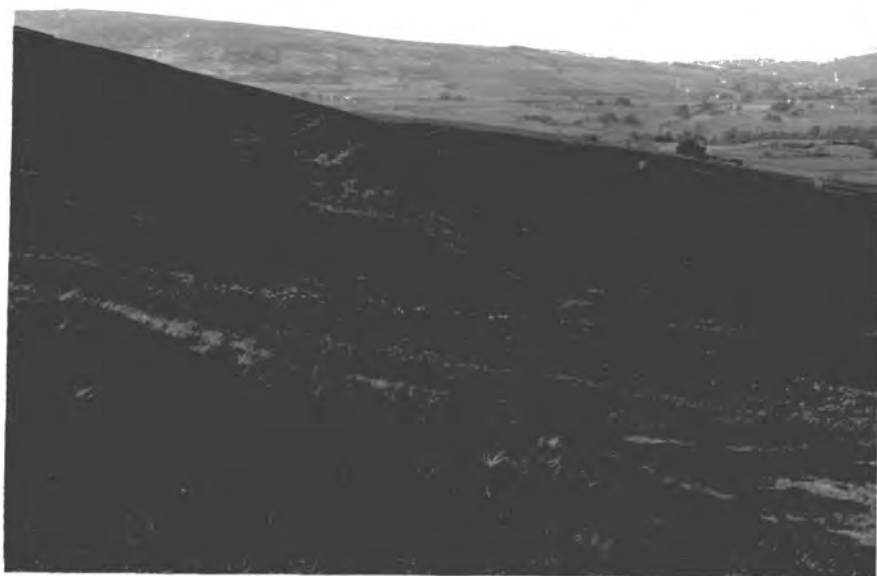
c. Channels in the Thornhope Burn.

This area has the most concentrated series of meltwater channels in the South Tyne valley (Fig. 5.4). Several small channels are to be seen on the western slopes of the Thornhope Burn and are indicated in Figure 5.4. A great variety of channel form is seen; chute, in-and-out channels and sub-marginal channels are common (Plates 5.5, 5.6, 5.7 and 5.8 illustrate a few of the channels in this complex).

Channels a and b (Fig. 5.4) are shown in Plate 5.5. These two channels which run parallel to each other are separated by a small ridge some 8 or 9 feet high. Both of these channels have very low gradient and although the peaty infill obscures the erosional profile it is probable that they were formed marginally to the South Tyne glacier. The sub-marginal channels in the complex are of two types. Some have well developed channels (Fig. 5.4, channels c and d; Plates 5.6 and 5.7). Others are sinuous benches the outer wall of the channel having been in ice (Plate 5.8).

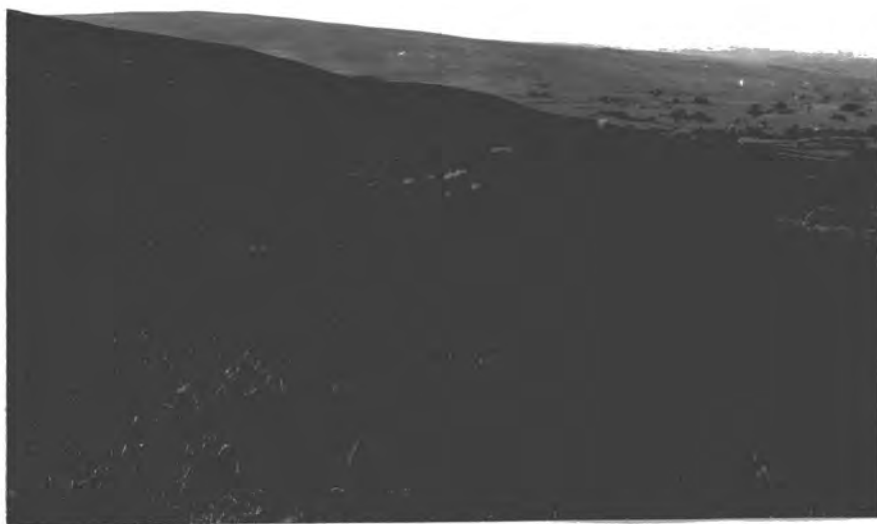


Plate 5.5



Channels a and b (Fig. 5.4) - view looking north.

Plate 5.6



Channel c (Fig. 5.4) - view looking north.

An equally complex system of channels is to be seen on the eastern banks of the Thornhope Burn (Fig. 5.4). Channel e is a large channel 150 feet wide and c.50 deep. It starts very abruptly well above the present level of the Thornhope Burn. Channel e is joined by two larger tributary channels, f and g (Fig. 5.4), which also start abruptly and descend into a broad shallow basin where they join channel e. Their very abrupt heads and lack of regard for the topography suggests that these large channels were probably formed subglacially. A further reason for suggesting such a mode of origin is that they occupy an ideal site for the development of subglacial drainage at the confluence of two valleys where crevasse systems are often developed. It was previously mentioned that subglacial drainage often bears a close relationship to crevasse patterns.

Channel h (Fig. 5.4) has two heads both of which start very gently. From its position channel h is probably part of the same subglacial system as channels e, f and g.

One of the most spectacular channels in the South Tyne valley is the great gash which separates Little Heaplaw and Great Heaplaw (channel i, Figure 5.4). This channel cut into solid rock is c.150 feet wide and four hundred yards long and is a classic example of a severed spur channel. It makes a very abrupt start at c.1350 feet and maintains a steady gradient of six degrees towards its outlet on the eastern side of the spur. Two small channels can be seen running into the entrance of channel i (Fig. 5.4). The presence of these two smaller channels together with the fact that it is most unlikely that an ice-dammed lake developed of the western side of the spur, militate against this channel having been formed as a lake spillway. Fabric analysis of tills in the Thornhope Burn indicate that ice at one stage in the glaciation was moving across the valley in an easterly direction; a similar alignment is seen in this large channel. It seems most likely in view of the lack of lake margins and deposits that this channel was formed in a similar manner to the superimposed channels described by Price in the Upper Tweed drainage basin (Price 1960).

Plate 5.7



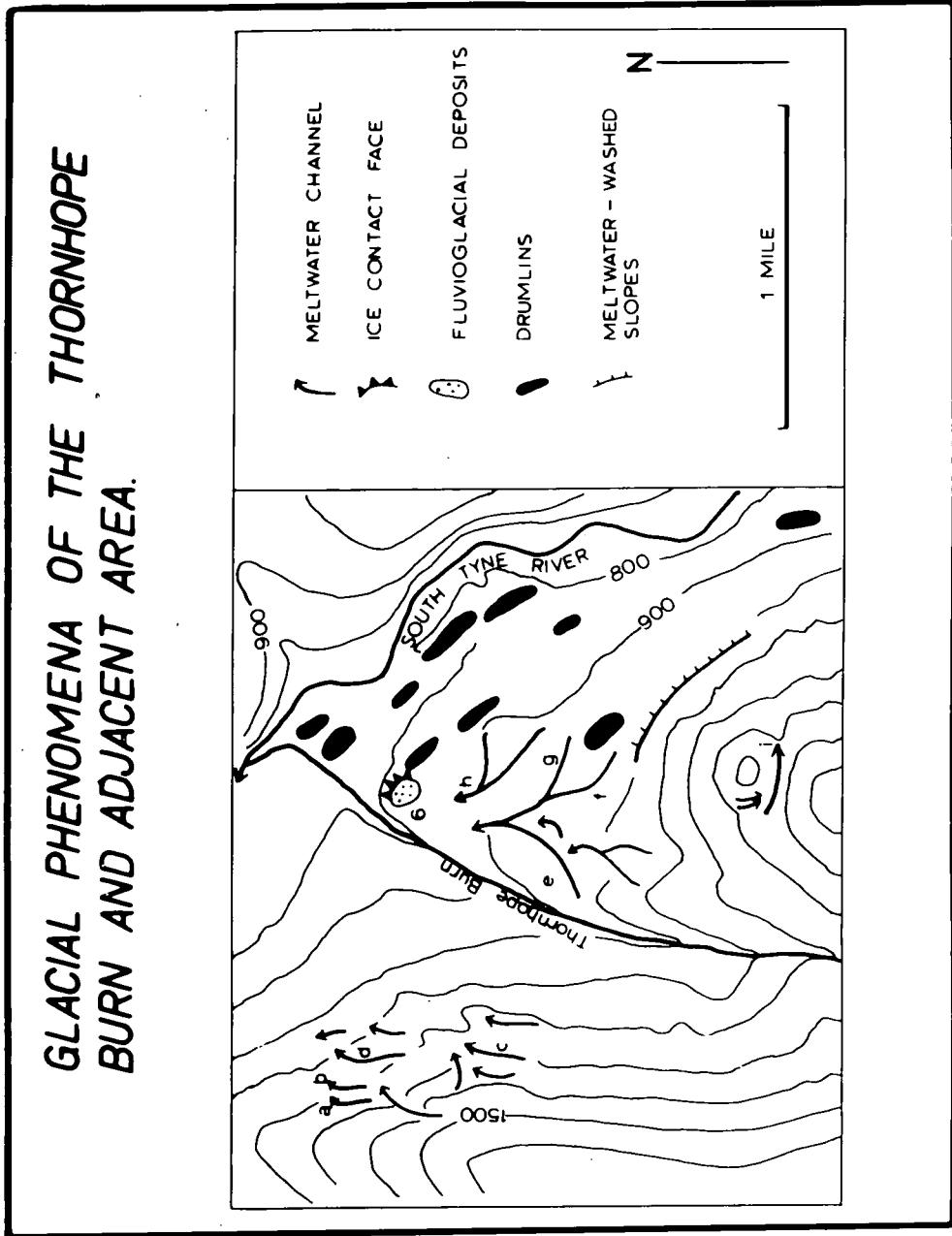
Channel d (Fig. 5.4) - view looking north.

Plate 5.8



Ice-marginal bench in Thornhope Burn complex. View looking south, Great Heaplaw channel can be seen in distance.

Fig. 5.4



d. Alston Area.

Several meltwater channels have been mapped north and north-east of the town of Alston (Fig. 5.5).

Two channels have been mapped on the northern slopes of the Ayle Burn valley (channels a and b, Fig. 5.5). Channel a intakes at 1140 feet O.D. and is continuous for nearly 600 yards. Its abrupt end and gradient strongly suggest that meltwater probably ran sub-marginally for a short distance and then seeped lower into the ice turning the channel into its subglacial course. Up slope of channel a, a chute (channel b, Fig. 5.5) intakes very abruptly at 1300 feet O.D. It is cut into solid rock and, where it ends equally abruptly, it is entrenched some 40 feet.

At some stage during deglaciation the Ayle Burn would have been filled with ice, and meltwater from the ice edge found its way under the ice by way of two chutes (channels c and d, Fig. 5.5) and a large subglacial channel (3, Fig. 5.5). Channel f (Plate 5.9) is a small in-and-out channel formed contemporaneously with channels c and d. Channel g (Fig. 5.5) starts abruptly at 1550 feet and for a hundred yards or so follows the contours around the hillside after which it descends the slope, chute-like, ending quite abruptly at 1400 feet O.D.

Three channels h, i and j are found on Newshield Moss (Fig. 5.5). The positions of channels h and i and the multiple head of channel j would seem to indicate a subglacial mode of origin. Their general alignment in a north-east south-west direction is in agreement with the subglacial channels mapped by the writer a few miles to the east at the head of West Allen Dale, and also channels mapped by A. G. Lunn in the South Tyne valley south of Alston (personal communication). The evidence suggests that at the time of the formation channels h, i and j (Fig. 5.5) the regional ice slope was towards the north-east.

The only channel identified on the western bank of the River South Tyne within the Alston area is channel k (Fig. 5.5, Plate 5.10). This channel, cut in till, is nearly 1000 yards long. It starts quite suddenly and runs in a north-westerly direction following the main axis of the South Tyne Valley.

Fig. 5.5

# MELTWATER FEATURES AROUND ALSTON

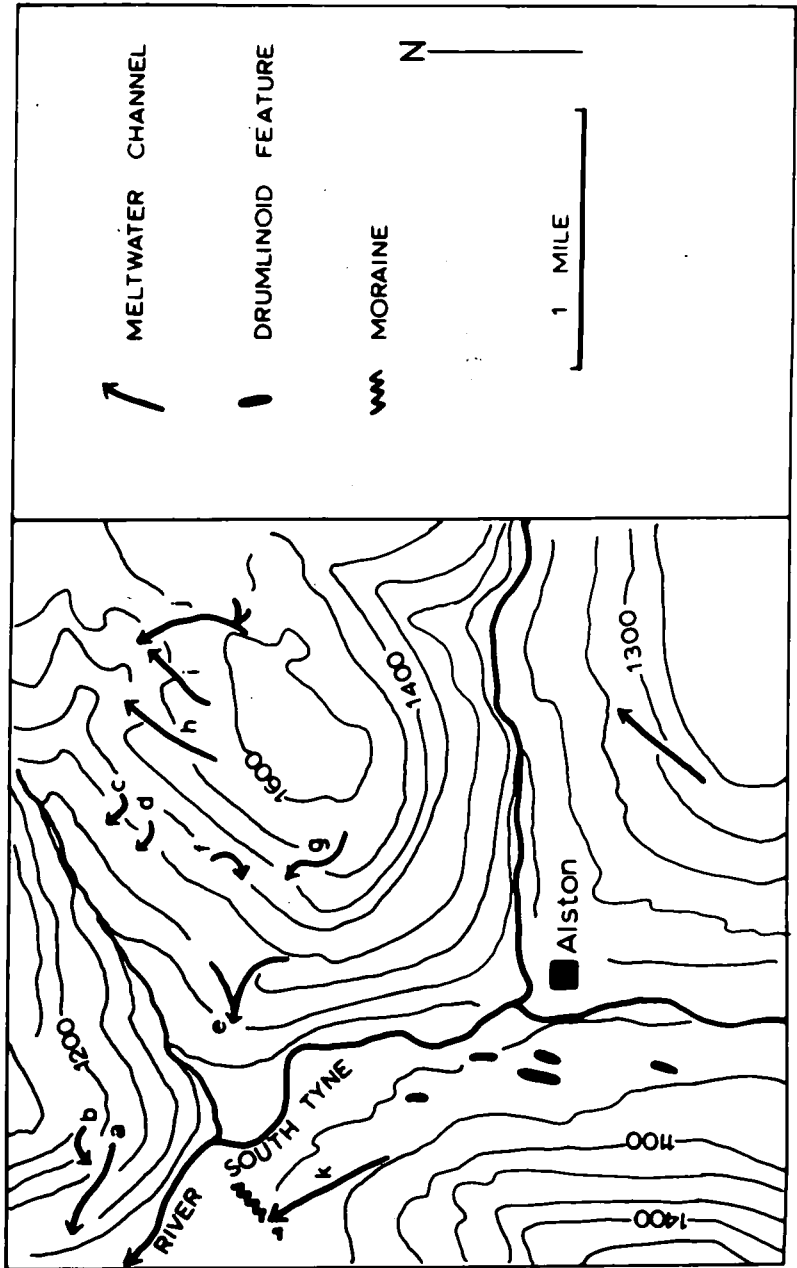


Plate 5.9



Channel f (Fig. 5.5) - view looking north-east up the Ayle Burn.

Plate 5.10



Channel k (Fig. 5.5) - view looking south.

Just before reaching the Gilderdale Burn it passes through a large mound of morainic material. Undoubtedly this channel is associated with the valley glacier stage of deglaciation. Whether or not it was formed sub-marginally or subglacially is not clear, but its general direction indicates an ice-slope towards the north.

### The Deglaciation of the South Tyne Valley - Meltwater Evidence.

No more than a skeleton outline of the deglaciation of the South Tyne valley can be attempted here. Meltwater channels are not numerous and marginal channels, so useful in the reconstruction of ice limits, are rare.

#### Stage i.

An early stage in the deglaciation the evidence from meltwater channels suggests two regional ice-slopes. The first, sloping to the east, represents the incursive ice originating in the Eden valley (Butt Hill channel Fig. 5.2; channel i, Fig. 5.4). The second is an ice-slope with a trend towards the north-east (channels h, i, j. Fig. 5.5) representing ice produced in the Cross Fell area.

#### Stage ii.

With the lowering of the surface of the ice the watersheds surrounding the South Tyne valley and its tributaries came out of the ice cover. Several sub-marginal, marginal and chute channels indicate this stage but the evidence is not clear enough for a detailed sequence to be stated. Having shrunk down into the main valley the ice took on the nature of a valley glacier with subglacial and sub-marginal drainage flowing towards the Tyne Gap.

#### Stage iii.

Clear indications of the retreat phases of the South Tyne glacier are not visible in the field. Several channels (d and e, Fig. 5.3; k, Fig. 5.5) because of their valley bottom positions and relationships with till deposits are thought to have drained away from the terminus or margins of the downwasting, and therefore backwasting, South Tyne glacier.



## 2. Meltwater Channels of West Allen Dale.

### a. Upper West Allen Dale.

Eight meltwater channels have been mapped at the head of the Wellhope Burn, a large west bank tributary of the River West Allen. As far as the writer is aware these channels have not previously been recorded despite their marked inprint on the landscape. None of these channels breaches the watershed, hereabouts at 1650 feet O.D., although several of the larger channels (b, c, d and g, Fig. 5.6) begin above 1600 feet O.D. These large channels represent some of the highest channels recorded in the area. Channel c (Fig. 5.6) is particularly spectacular, being over 60 feet deep, 100 feet wide and well over one mile long. Plate 5.11 illustrates channel d (Fig. 5.6) which is joined in its lower course by two tributary channels.

Without doubt this group of channels cannot be regarded as having been formed in a sub-aerial environment as lake spillways as none of their courses breach the watershed. Their general north-east south-west alignment and the presence of till in their floors suggests, in a similar way to channels h, i and j on Newshield Moss (Fig. 5.5), that they were formed subglacially under an ice cover sloping towards the north-east and away from the Cross Fell area.

Further evidence of this regional ice slope is indicated by the smaller channels which are found on the spur between the Mohope Burn and the River East Allen (Fig. 5.6). Channels l, m and n (Fig. 5.6) are small chute features while channel k is a distinct channel some 30 feet wide and 300 feet long which occupies a small col at 1600 feet O.D.

### b. Ouston Fell.

Four large channels have been mapped on the tract of moorland known as Ouston Fell (Fig. 5.7). Channel a (Fig. 5.7 and Plate 5.12) was held by Dwerryhouse, (1902) to be a lake spillway. Dwerryhouse (1902) supposed that it drained water from a glacially-dammed lake held up in the Ayle Burn, into a lake in the West Allen valley. Lake Ayle was also supposed to have been fed by a lake spillway draining water from a lake held up in the upper part of the Barhaugh Burn (Fig. 5.7). A careful search of the moorland between the Barhaugh and Ayle Burns failed to find such a spillway. The lake spillway hypothesis for channel a (Fig. 5.7) can be criticised on several

Fig. 5.6

# MELTWATER CHANNELS IN UPPER WEST ALLEN DALE

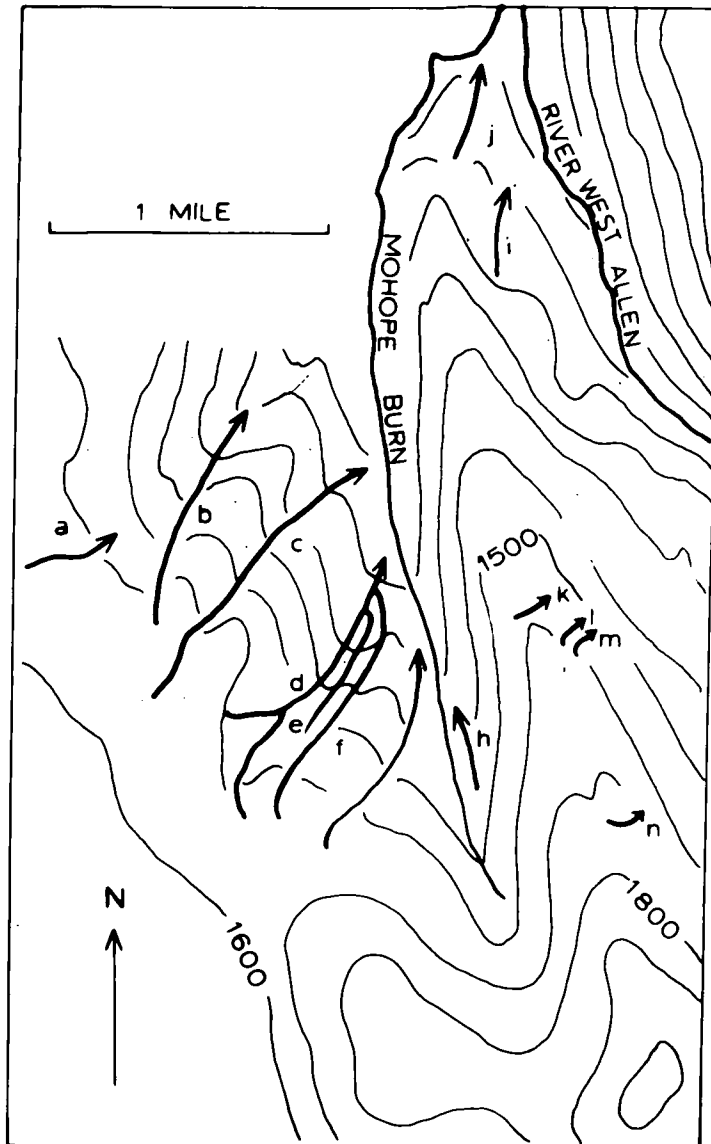


Plate 5.11



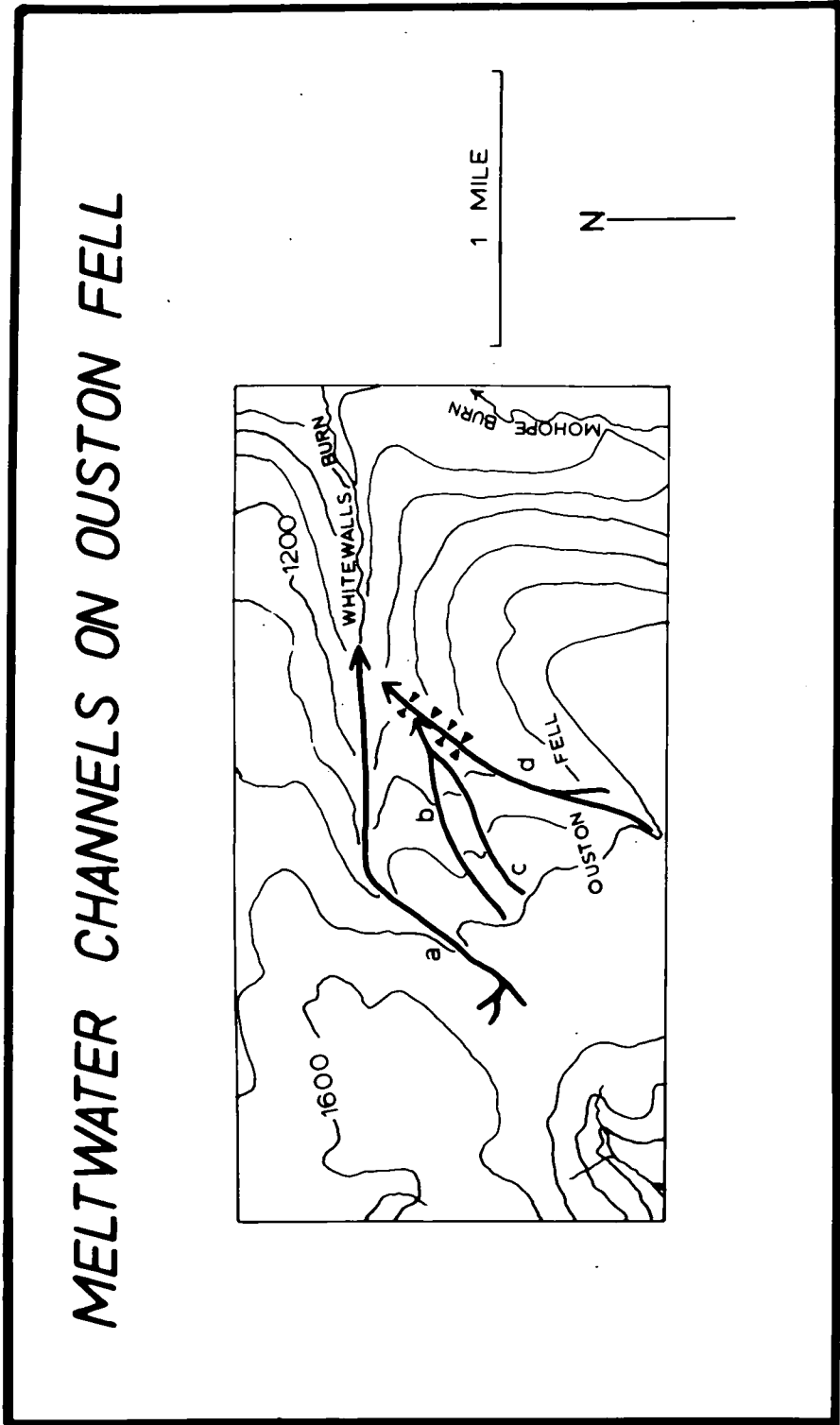
Channel d (Fig. 5.6) - view looking north-east.

Plate 5.12



Channel a (Fig. 5.7) - view looking south-west.

Fig. 5.7



grounds. Firstly, no clear breach of the watershed between the Ayle and Whitewalls Burn is seen in the field. Secondly, channel a has more than one head and there seems no marked orientation of the heads towards the Ayle Burn. Dwerryhouse (1902) also failed to notice the equally large channels b, c and d (Fig. 5.7) which could not possibly be explained by lake overflows as conceived by that writer, all three beginning some way short of the watershed.

Channel d (Fig. 5.7) is particularly impressive and in its lower parts is occupied by a small stream. At one point this channel passes through an impressive rock-cut gorge some 80 feet deep which could not possibly have been cut by the very misfit stream which now occupies the valley.

When viewed in a regional context these channels are most easily explained as having formed subglacially under the same north-easterly sloping ice sheet that formed the large channels at the head of the Wellhope Burn (Fig. 5.6).

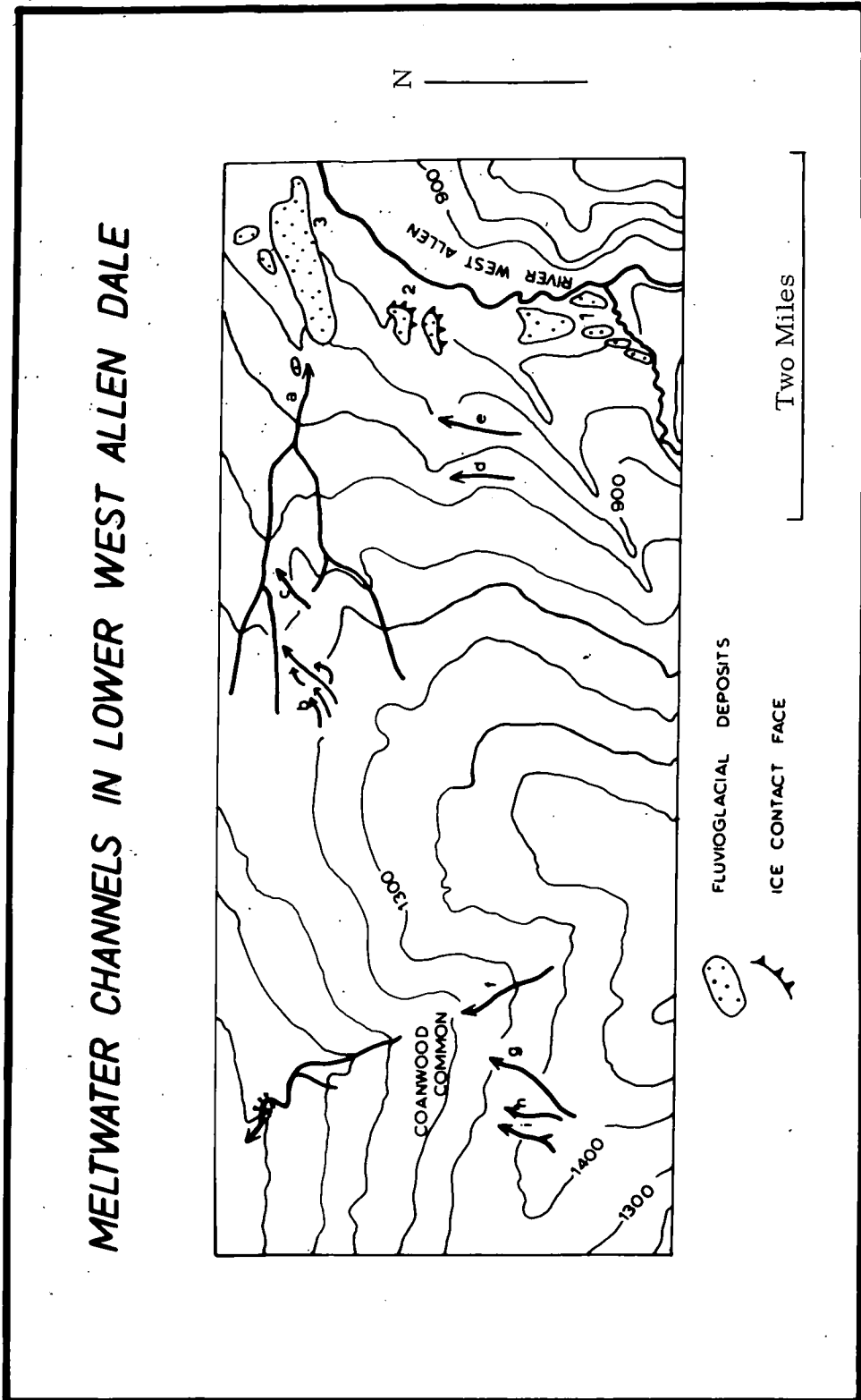
c. Lower West Allen Valley and Coanwood Common.

Meltwater channels are absent from the middle reach of the West Allen Dale and only become evident near the confluence of the East and West Allen rivers. Several previously unrecorded channels are also seen in the upper part of the Coanwood basin (Fig. 5.8).

Channel a (Fig. 5.8) is a large channel over 70 feet wide at its maximum. Although in its lower course channel a is occupied by a small stream, the Church Burn, several dry meltwater channels form accordant tributary junctions suggesting that the Church Burn, which is underfit, drains a large subglacial channel.

Several smaller, sub-marginal, in-and-out and subglacial channels on Witchall Moss (Fig. 5.8) lead down into a tributary branch of channel a indicating that meltwater flowing sub-marginally and subglacially on Witchall Moss found its way under the ice into the large subglacial trunk system. The orientation of this system is in harmony with other evidence which suggests that at one stage the ice slope in this area, as in the Tyne Gap proper, was towards the east or a little south of east. A few shallow sub-marginal channels (d and e, Fig. 5.8) are seen on the western slopes of the West Allen Dale.

Fig. 5.8



Channels f, g, h and i (Fig. 5.8) on Coanwood Common have not been previously described. All four have typical meltwater channel morphologies with steep sides and flat peaty floors. Their abrupt beginnings in blind amphitheatre-like heads, some way short of the watershed indicate a subglacial origin. If this is the case then their north-easterly orientation was determined principally by the slope of the ice-surface at the time of their formation. From fabric and stone count evidence it is known that at one stage that ice must have been crossing the Coanwood Common in an almost west-east direction, and it is necessary to explain the somewhat anomalous direction of these meltwater channels. A possible explanation is that these meltwater channels were formed at some period during the deglaciation when ice movement down the South Tyne valley was a strong influence on the direction of the ice-slope. Outside of the valley bottom, with its strong topographic control on ice movement, the ice passing slowly down the South Tyne valley at a high level would have turned eastwards over Coanwood Common towards the West Allen Dale, thus providing the necessary ice-slope.

#### Meltwater Evidence of the Deglaciation of the West Allen Dale.

It is not possible, because of the scant nature of the evidence to reconstruct stages of deglaciation in the West Allen Dale.

Certainly, at some stages in deglaciation there is evidence of at least two streams of ice movement. The south-westerly stream of ice probably emanated from the Cross Fell area and is indicated by numerous subglacial channels all of which are orientated in a general south-west north-east direction. In the north of the area there is evidence for a west-east flow of ice indicated by the meltwater systems in Figure 5.8.

From stone count evidence in the East Allen Dale, where some tills contain erratic material, it must be concluded that the ice issuing from the Cross Fell area was a later stage in the deglaciation, after the maximum inundation of ice, when a west-east movement prevailed. If such a flow were contemporaneous with a west-east flow of ice in the West Allen Dale it could only have occurred by the superimposition of the two ice-sheets, and erratic material would be present in the tills. No erratic material has been found within that part of West Allen Dale showing evidence of the north-easterly

sloping ice surface. Unfortunately, this later incursion of ice has left few traces of its wastage. Channels d and e (Fig. 5.8) and channel i (Fig. 5.6) are the only indications found of its downwasting.

### 3. Meltwater Channels of East Allen Dale.

#### a. Allenheads Area.

Two previously unrecorded channels are found at the head of the East Allen Dale (Fig. 5.9). Channel a (Fig. 5.9 and Plate 5.13) is cut into rock and is some twenty feet deep at its maximum. It starts very abruptly just north of the watershed at approximately 2000 feet O.D. which is here covered with a blanket of peat. This channel, one of the highest found in the region has a general north-easterly orientation and was formed subglacially under the same ice-sheet which accounted for the channels at the head of the Wellhope Burn.

Channel b (Fig. 5.9 and Plate 5.14), which has a multiple intake, runs north-eastwards away from the col which is the only significant break in the watershed forming the southern boundary of the West and East Allen Dales.

The complex multiple head of channel b precludes the possibility of it being a lake spillway. Moreover its general orientation is similar to all the other subglacial channels found in the southern parts of the West and East Allen Dales. Neither of these channels were recognised by Dwerryhouse (1902) who considered that the high watershed, on which these channels are carved, was an ice-free area.

#### b. Allendale Common.

In many ways the channels mapped by the writer on Allendale Common (Fig. 5.10) provide the most convincing evidence for the subglacial origin of the meltwater channels in the north-west Alston Block. It is across this Common that a lake spillway, from a lake in the West Allen Dale to a lake in East Allen Dale was supposed to have drained (Dwerryhouse 1902).

Two channels, a and b (Fig. 5.10) are the only evidence of meltwater actively in the Swinhope Burn (Plate 5.15 and 5.16). Both are cut in solid rock and descend into the valley in the fashion of subglacial channels.



Fig. 5.9

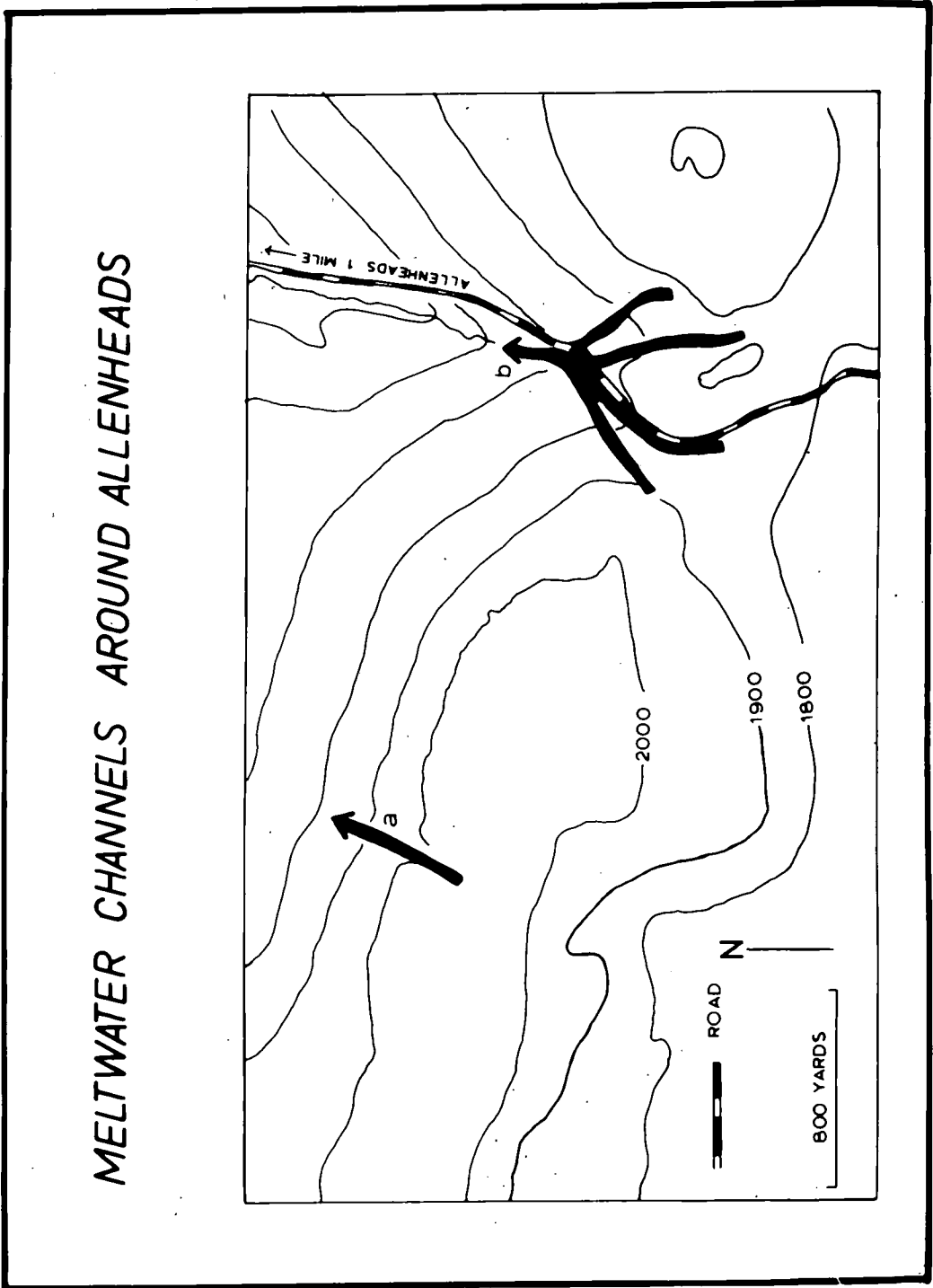


Plate 5.13



Channel a (Fig. 5.9) - view looking north-west.

Plate 5.14



Channel b (Fig. 5.9) - view looking south.

Their alignment suggests that they were probably formed by a single subglacial stream, in part flowing subglacially, in part englacially.

Channel c (Fig. 5.10), which is incised some 40 feet into massive sandstone, is part of a small complex of subglacial channels on the eastern flanks of Knockshild Moor. One tributary arm of channel c commences at 1720 feet O.D. (Fig. 5.10). One of the few marginal channels seen in the East Allen Dale is channel d (Fig. 5.10) which indicates an ice margin at c.1400 feet O.D. at some stage in deglaciation of the valley.

An interesting channel complex is seen at the head of the Acton Burn (Fig. 5.10). Channel f (Fig. 5.10) is one of the most spectacular channels of this complex. It occupies the floor of a shallow col at c.1625 feet O.D. where it is some 70 feet wide and 25 feet deep. The entrance of this channel is shown in Plate 5.17. After a short distance it has become gorge-like some 60 feet deep with precipitous sides (Plate 5.18). It was because of the manner in which this channel breaches the col (Plate 5.17) that Dwerryhouse (1902) was able to use this channel as a convenient spillway from a lake in the West Allen Dale. Such an interpretation is not supported by field evidence.

A short distance to the south-west, a smaller channel (channel e, Fig. 5.10 and Plate 5.19) breaches the watershed in a manner similar to channel f. That Dwerryhouse should have ignored this channel remains a mystery. It is also puzzling why Dwerryhouse (1902) made no mention of the smaller channels which feed into channel e and f (Fig. 5.10).

It would be difficult to explain this complex as having formed as lake spillways. A good clue to the origin of both the large and small channels of the Common is seen in channel g (Fig. 5.10), the abrupt, blind head of which, is seen in Plate 5.20. This channel could not possibly have been formed as a spillway. The sum of the evidence indicates that the whole system was formed subglacially, some meltwater being forced through shallow cols, other meltwaters impinging abruptly on the ground surface.

#### e. Meltwater channels of the Sinderhope Area.

Several of the meltwater channels of the Sinderhope area have been previously noticed by Dwerryhouse (1902) and Sissons (1958a). Dwerryhouse (1902)

Fig. 5.10

## MELTWATER CHANNELS ON ALLENDALE COMMON

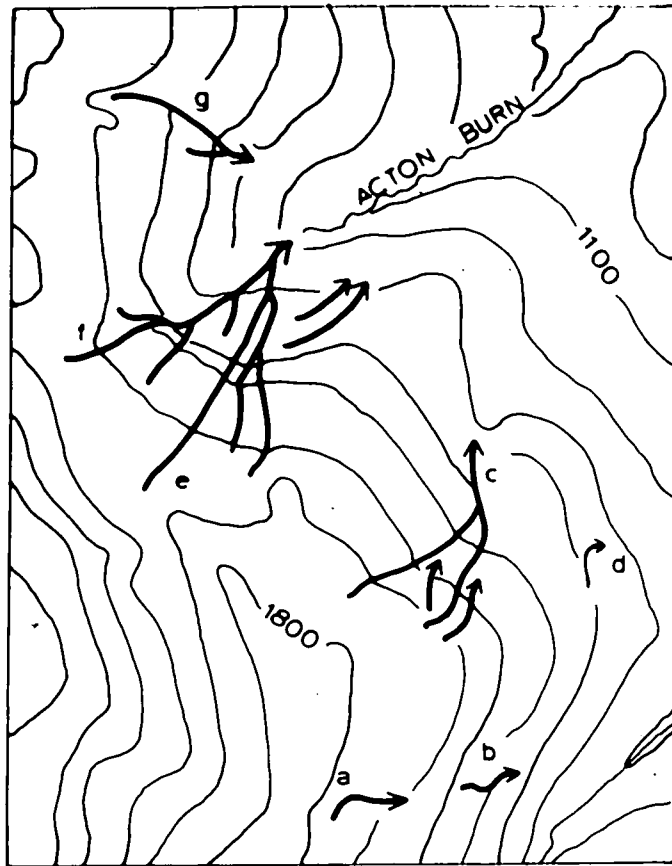


Plate 5.15



Channel a (Fig. 5.10) - view looking south-east.

Plate 5.16



Channel b (Fig. 5.10) - view looking south-east.



View, looking north, of the interfluvium between West and East Allen Dales.  
Entrance to channel f (Fig. 5.10) is indicated by the arrow.

Plate 5.18



Aerial view of channel f (Fig. 5.10) looking westward.

Plate 5.19



Mouth of channel e (Fig. 5.10) - view looking north.

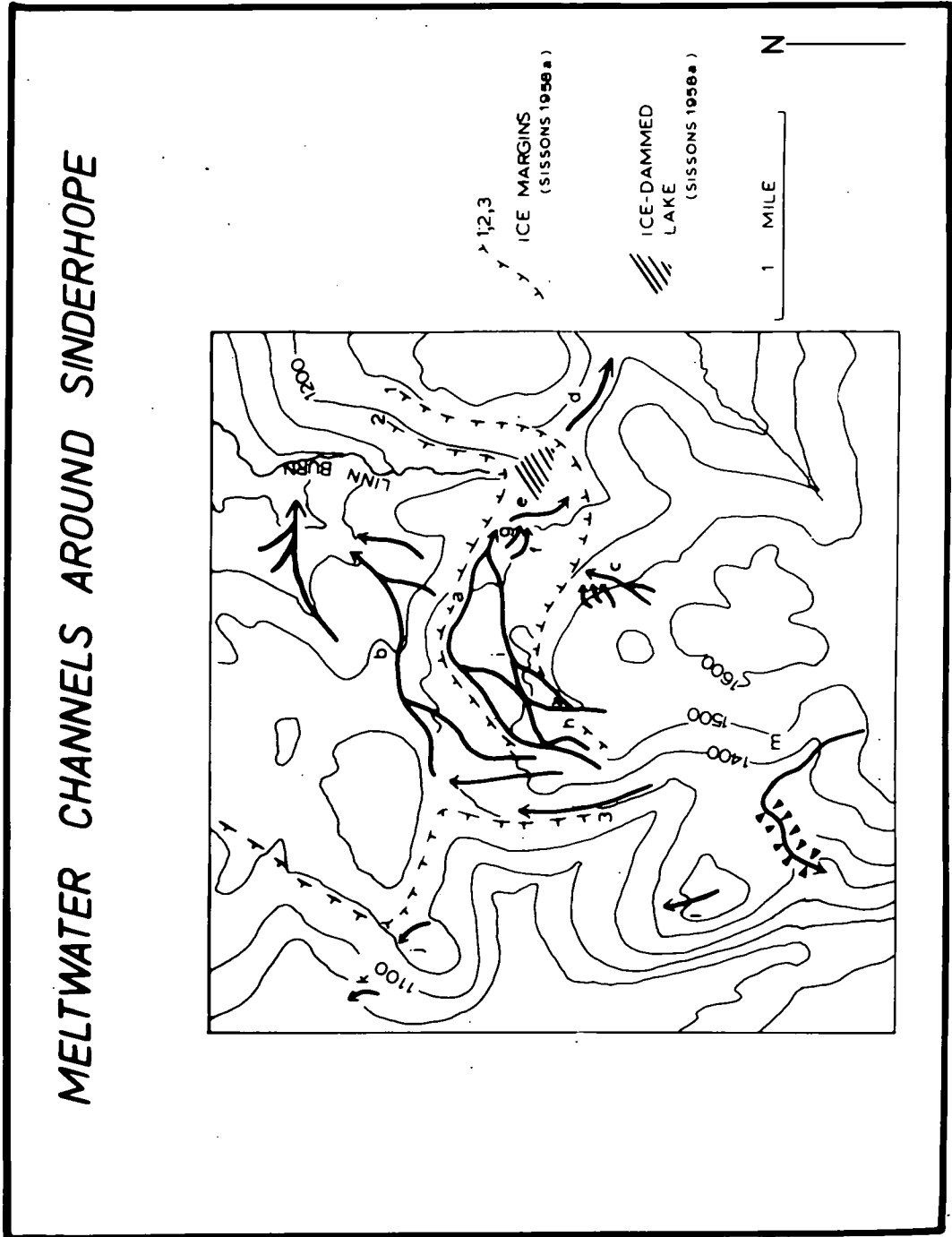
Plate 5.20



Abrupt beginning of channel g (Fig. 5.10) confirming the view that it is not a lake spillway - view looking north-west.



Fig. 5.11



mentioned only four channels on the col between the East Allen river and the Linn Burn, the most southerly of which he thought conveyed water from an ice-dammed lake in East Allen Dale to a lake at the head of the Linn Burn. Sissons (1958a), re-mapped the channels occupying this col area and could not accept Dwerryhouse's conclusion. In his paper Sissons (1958a) argued that meltwater flowed marginally along channel a (Fig. 5.11) and fed a small lake, now indicated by a flat marshy area, at the head of the Linn Burn. With the abandonment of channel a meltwaters followed channel b (Fig. 5.11). Sissons (1958a) argued that unless one interprets channel b as having formed beneath the ice one is faced with several difficulties.

Firstly, one would have to maintain that while the ice thinned about 100 feet or so and its edge retreated about 250 yards on the western side of the col, a much greater thickness of ice completely disappeared from the Linn Burn valley.

Sissons also suggested that one would also be faced with the difficulty of accounting for the absence of marginal channels between channels a and b (Fig. 5.11).

At the time of writing Sissons (1958a) suggested several ice margins indicating the stages of ice retreat from the area. These margins are indicated in Fig. 5.11.

During the 1967-8 field season the writer re-examined this channel complex: several points arose from this re-examination.

Both Dwerryhouse (1902) and Sissons (1958a) inferred a lake in the upper part of the Linn Burn during the deglaciation of this area. In order to substantiate their views a series of borings were made using a Hiller peat borer to try and locate any lake deposits that may be present. The general sequence, confirmed at several sites in the locality of the supposed lake was as follows: up to three metres of peat with abundant Birch and Alder remains; c.30 centimetres of weathered grit passing into solid rock. No lake deposits were found.

The absence of such a lake is not surprising if the evidence of the meltwater channels is taken into consideration. Ice margin 1 (Fig. 5.11)

based on Sissons (1958a) does not explain channels a and c (Fig. 5.11). One must infer that at one stage the ice margin in the upper Linn Burn must have been at least 1500 feet O.D. This being so the large channel d (Fig. 5.11) could have been formed subglacially, for the ice would have covered the ridge through which it cuts. In the field the abrupt start to channel e is most noticeable. This channel is some 40 feet deep and 60 feet wide and is joined by two small subglacial streams (f and g, Fig. 5.11). Only a short distance away, a matter of a few hundred feet, channel a ends abruptly, well before the flat marshy area indicated by Sissons (1958a). It is likely that channels a and e are part of one single system. The questions arise as to whether this system, channels a and e (Fig. 5.11) is marginal as suggested by Sissons (1958a) or subglacial, and whether or not gradients alone are a critical enough criterion for classifying channels?

Certainly, channel a appears to have a low gradient, for the most part less than 4 degrees, but without borings to indicate the erosional profile such figures are not very meaningful as most of these channels are filled with peat to a considerable depth.

Some slight evidence that channels i and a (Fig. 5.11) are subglacial and not marginal is indicated by the junction of undisputed subglacial streams which have gradients of ten or more degrees (channels f, g and h, Fig. 5.11).

Without exception the junction of these smaller subglacial streams is entirely accordance with the larger channels which they join. This might indicate the contemporarity of both large and small channels, the whole functioning as an anastomosing subglacial system.

Sissons has since indicated to the writer that many of the channels he formerly suggested were marginal (Sissons 1958a) are now better interpreted as being subglacial. Sissons now considers the whole system to be the results of "Vast subglacial rivers, perhaps flowing at a considerable depth" (Sissons, personal communication).

The upper part of channel a (Fig. 5.11) is shown in Plates 5.21 and 5.22. Several smaller channels formed during the downwasting of ice in East Allen Dale are found at lower levels on the valley sides (channels k, j and l (Fig. 5.11)).

A particularly spectacular feature attributable to meltwater action is the gorge-like feature at Sipton Clough (channel m, Fig. 5.11 and Plate 5.23). In its north-westerly flowing section this channel is broad and open. Then, quite abruptly it turns westwards and runs in a deep gorge towards the East Allen river. Although the gorge is occupied by a small stream it is most improbable that it could have formed such a large feature.

In an area such as this with a long history of lead mining it is not always possible to exclude anthropogenic factors in interpreting present-day morphology. An examination of Sipton Clough revealed no evidence of hushing or mining. This was confirmed in an examination of mining plans made available at Allen Dale Estate Offices, Allenheads. It is concluded that Sipton Clough is yet another of the variable forms created by glacial meltwater.

e. Eshells Moor.

Several large meltwater channels traverse Eshells Moor in a general west-east direction. The southern most group (Fig. 5.12) are described by Sissons (1958a) who then suggested a marginal origin for channels b, c and d (Fig. 5.12). As previously indicated, Sissons now regards these channels as having formed subglacially. Such an explanation is by far the most reasonable for these large trench-like features. Figure 5.12 indicates the complexities of the channel heads which would require incredibly complex oscillations of an ice margin if they were formed marginally.

Similarly, channels e, f, and g (Fig. 5.12) with their multiple intakes, and accordant tributary junctions, are most easily explained as subglacial channels indicative of a regional ice-surface sloping towards the east.

Deglaciation of East Allen Dale.

No detailed account of the deglaciation of East Allen Dale can be reconstructed from the evidence provided by meltwater channels which are most sporadically distributed.

Several systems (channels in Figs. 5,10, 5.11 and 5.12) indicate that at an early stage meltwater was being directed by ice which sloped in an easterly direction. A similar early stage has been recognised in the South Tyne valley and in the West Allen Dale.



Lower part of channel a (Fig. 5.11) - view looking north.



Upper half of channel a (Fig. 5.11) - view looking south-west.

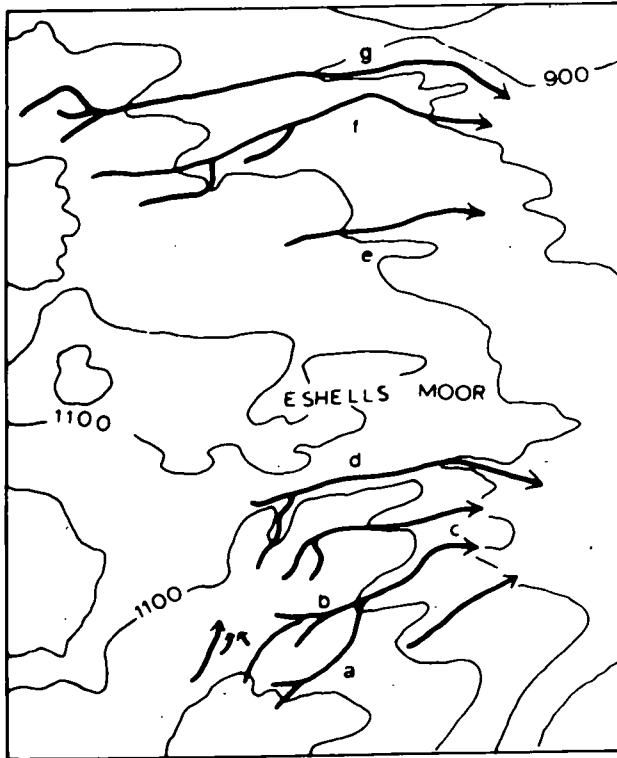
Plate 5.23



Sipton Clough (channel in Fig. 5.11) - view looking east.

Fig. 5.12

# MELTWATER CHANNELS ON ESHELLS MOOR





In the Allenheads area (Fig. 5.9) meltwater channels are orientated in a more northerly direction indicating a regional ice-slope away from the Cross Fell region.

The almost total absence of meltwater features at lower levels in the East Allen valley inhibits discussion of the later stages of deglaciation based on such features.

#### Regional Meltwater Drainage.

Before leaving the subject of meltwater channels it is useful to place the channels described in this chapter in a wider context.

Figure 5.13 indicates the major meltwater features found in the north-east Alston Block. It is immediately obvious that the dominant orientation of these larger channels is easterly. Such an orientation clearly illustrates the drainage of meltwater away from the thick accumulations of ice which must have occupied the Vale of Eden and the Carlisle Plain. The orientation of a few channels found in the south-west of the area suggest meltwater drained north-easterly from the Cross Fell region and joined the main west-east systems.

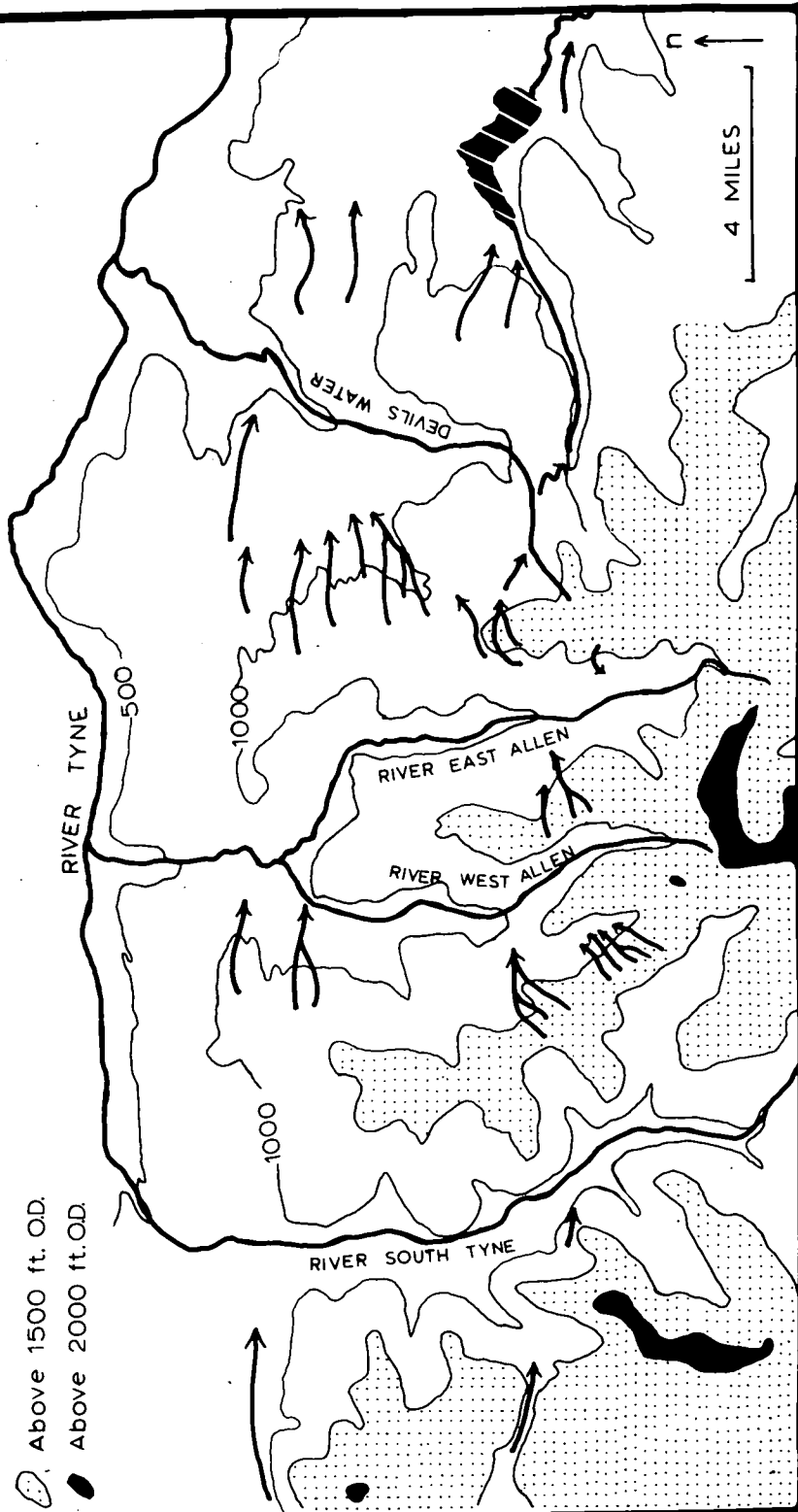
Evidence for the continuity of these vast subglacial rivers is limited and it would be foolish to more than speculate at this stage of our knowledge. Certainly, many of the larger meltwater channels are aligned in such a way as to suggest that they were formed by one large meltwater river. Discontinuities in the morphological expression of such subglacial rivers would occur where they flowed in ice rather than impinging on bed rock.

To illustrate this point further one such system of large meltwater channels, probably formed by one continuous meltwater system is briefly described.

Several large meltwater channels have been described in the Sinderhope area of East Allen Dale (Fig. 5.11). Many of these channels are aligned with a very large channel, Rowantree Clough (Fig. 5.11, channel d). This channel in turn is aligned with the entrance of the Beldon Clough (Plate 5.1). Not only are these channels aligned so as to create the impression of their having been formed by one vast meltwater river, but the overall size of the channels increases as the system is traced from west to east, suggesting that

Fig. 5.13

# THE DISTRIBUTION OF MAJOR MELTWATER CHANNELS



the meltwater river grew in size as more and more tributary drainage was gathered.

If accurate cross profiles could be obtained for such subglacial channels the volumetric relationships hinted at above may well provide valuable evidence as to the nature of the regional meltwater drainage.

### Conclusions.

A variety of meltwater forms have been described, many for the first time. Most have been shown to be subglacial in origin and the untenability of the lake spillways, in this context, demonstrated.

As general indicators of ice direction subglacial meltwater features provide useful complementary evidence to that gained by other techniques. The unfortunate lack of channels at lower levels precluded their use as delicate indicators of the later stages of deglaciation, so well demonstrated elsewhere.

Section 3.

**SEDIMENT ANALYSES.**

## Chapter 6.

### Till Macrofabrics and Glacial Striae.

#### Introduction.

The analyses of till macrofabrics has, in recent years, become one of the most useful techniques available to the glacial geomorphologist. Together with evidence from glacial striae it may provide valuable clues as to the directional movements of ice sheets.

#### A. Fabric Analysis.

Hugh Miller in 1850 was probably the first to report that many stones in till lie with their long axis parallel to the direction of the striae on their surface and thus parallel to the direction of ice movement. These early observations were elaborated by Hugh Miller the younger when, in 1884, he published probably the first critical observations on till-stone orientation. In describing the 'pavement boulders' in the till near Edinburgh, he stated (p. 167):

"The longer axis of the stone is often directed in the line of glaciation, and the pointed end is frequently, but not always towards the ice".

The results achieved by these early investigators failed to attract the notice they deserved. As recently as 1932 Twenhofel (p. 86) summarized contemporary opinion by stating that ground moraine consisted of 'unstratified and unorganised material'.

The general observations of the early Scottish geologists were not confirmed by accurate measurement of large numbers of till stones until Richter (1932) showed that the movement of the inland ice which deposited the Pomeranian moraines of North Germany could be reconstructed by such measurements. Like the younger Hugh Miller he reasoned that these stones had been orientated as streamlined bodies in the glacier and had been deposited with little or no change in orientation. A statistical grouping of long axis orientations indicated the direction in which the glacier was moving.

A most valuable account of till fabric analysis was published by Holmes (1941) who attempted to analyse the effect of shape on the orientation of stones within till.

The papers of Richter and Holmes provided valuable stimulus for further work in this field. The last twenty years or so has seen the publication of many papers on various aspects of the subject.

Many studies have been made using the technique of fabric analysis to solve problems of regional ice movement, e.g. Richter, K. 1932; Holmes, C.D. 1941; Virkkala, K. 1951; Dreimanis, A. and Reavely, G. H. 1953; West, R. G. and Donner J. J. 1956; Kirby, R. P. 1961; Kaiser, R. F. 1962; Penny, L. F. and Catt, J. A. 1967, and Beaumont, P. 1967.

Other workers e.g. Holmes, C. D. 1941; Hoppe, G. 1952; Glen, J.W. Donner, J. J. and West, R. G. 1957; and Harrison, P. W. 1957b, have concerned themselves with the genesis of the till fabric and the mode of till deposition.

Fabric studies have proved useful in solving problems relating to the genesis of certain glacial landforms. In particular the work of Hoppe, G. 1952; Wright, H.E. 1957 and Andrews, J. T. 1963, illustrates this aspect of the technique.

The studies so far described have concerned themselves with Pleistocene till. Much useful complementary evidence has been obtained from contemporary glaciers. Richter, K. 1936; Hoppe, G. 1953; Okko, V. 1955; Glen, J. W., Donner, J. J. and West, R. G. 1957; Harrison, P. W. 1957b, and more recently Schytt, V. 1962, have described orientation patterns in both marginal and subglacial environments.

#### Field Methods.

Wherever possible a natural exposure was chosen for fabric analysis. In order to avoid the effects of soil creep or periglacial activity all orientation measurements were made at least four feet below present ground surface. Natural exposures in till are not evenly spread over the area and for some localities information is therefore lacking. As several lines of evidence are used to establish the nature of ice movement it was not, after a consideration of the time involved, thought worthwhile to dig any pits for fabric studies.

Such pits would need to be at least 6 feet deep and this would certainly have more than doubled the time taken for each analysis.

At each exposure a face two feet by two feet was carefully cleared and the pebbles were excavated by means of a knife. Each pebble was carefully removed and the direction of the a-axis determined; it was then replaced. The orientation was measured with a prismatic compass (to the nearest five degrees). Only pebbles with a well defined a-axis of more than 1 cm. were measured and at each site the nature of the ground slope was carefully noted.

Because of the time taken to reach many of the more isolated sites and the time consuming nature of the technique itself it was decided to restrict the number of pebble measurements to fifty per site. Several workers have suggested that this is a sufficient number for reliable results (Holmes 1941, King 1966). At most exposure the tenacious nature of the till and the great difficulty in removing many of the pebbles meant that it was often only just possible to complete one analysis per day.

### Results.

This section is subdivided into two:-

- i. Methods of analysis of the data.
- ii. An interpretation of the regional ice movement as determined by fabric patterns.

#### i. Methods of analysis of the data.

Prior to any statistical analysis the data collected in the field were tabulated into 10 degree columns (Appendix 3) and plotted in histogram form. (Such an organisation was also a necessary preliminary stage to the vector analysis of the data). Rose diagrams indicating the patterns of preferred orientation were drawn (Fig. 6.1).

Until recently little statistical analysis has been applied to the study of till fabrics, or indeed to the problem of sample size. On this last point it is worthwhile considering some of the relevant literature on the subject.

Fig. 6.1

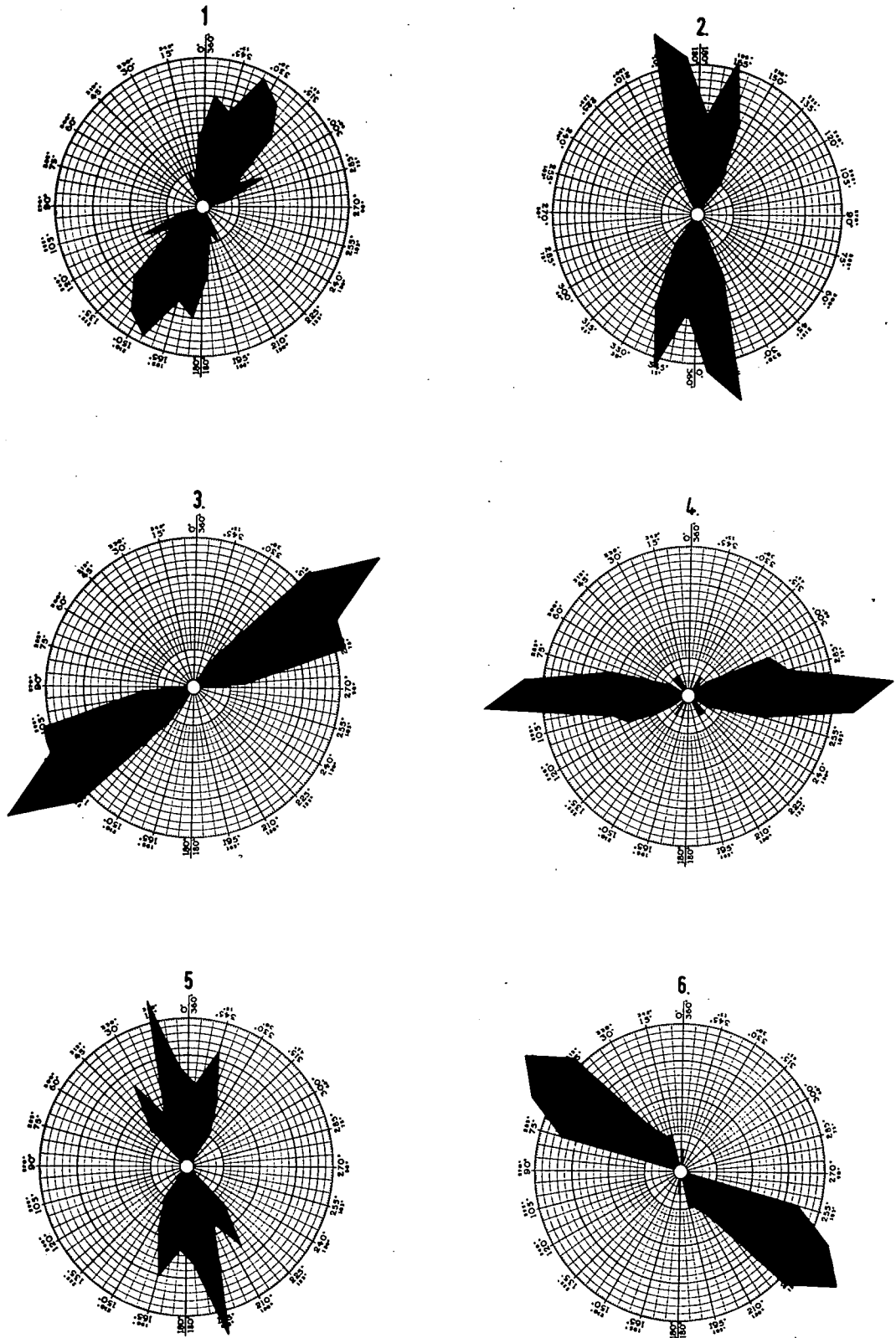




Fig. 6.1

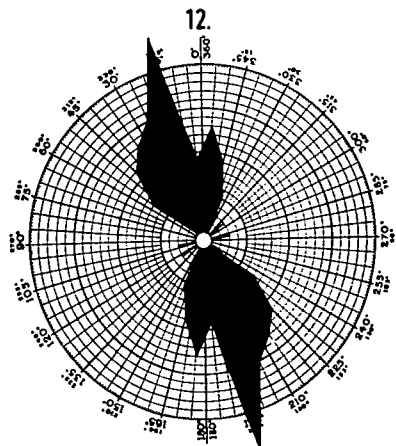
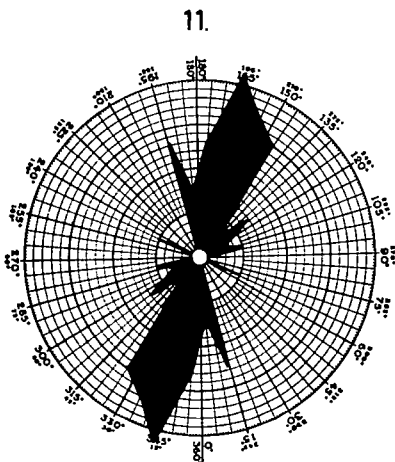
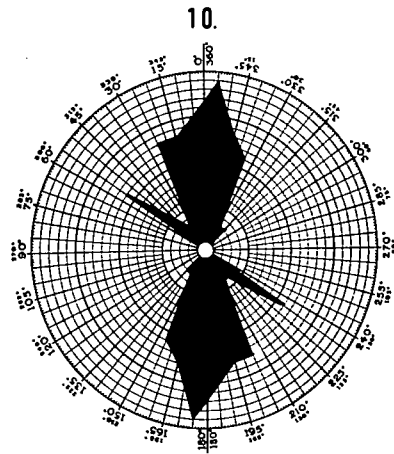
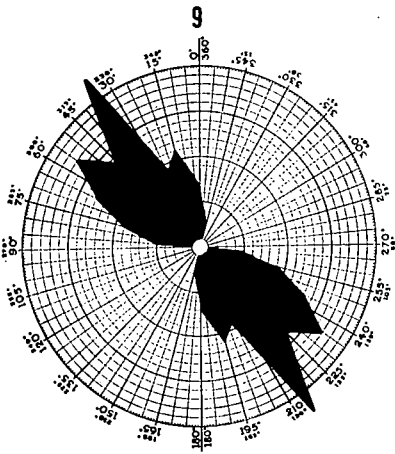
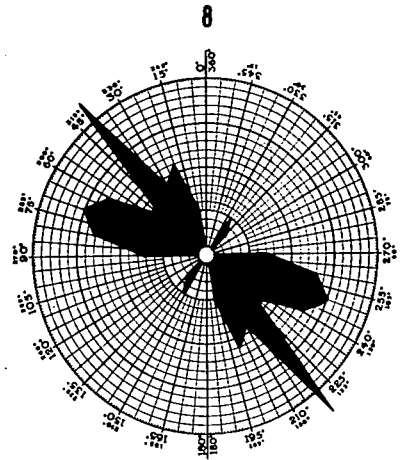
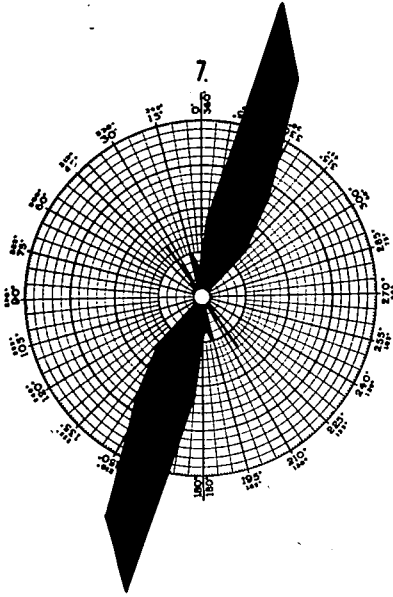


Fig. 6.1

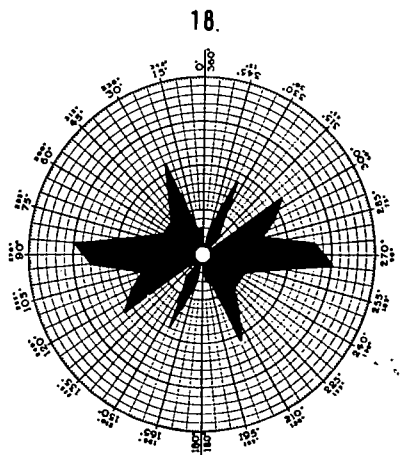
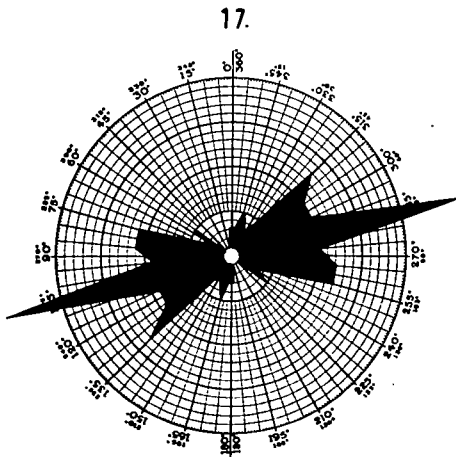
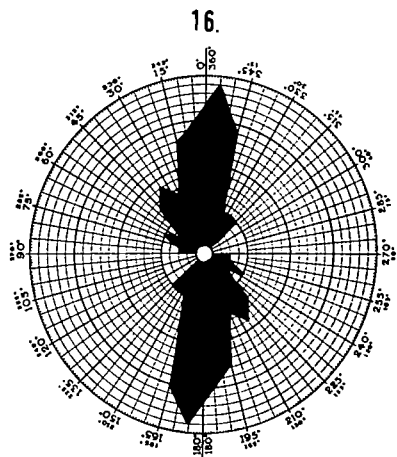
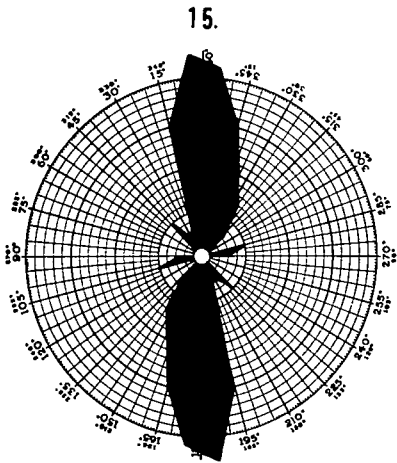
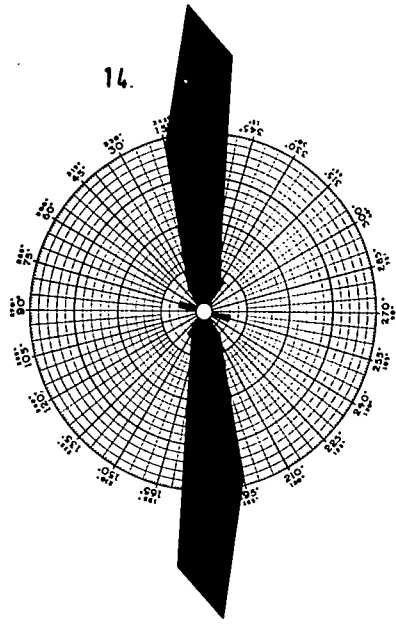
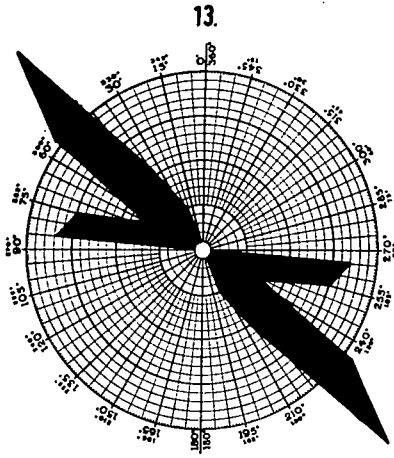
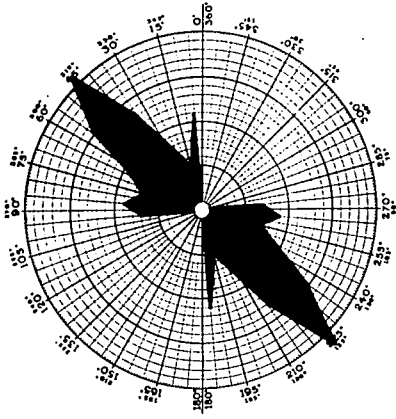
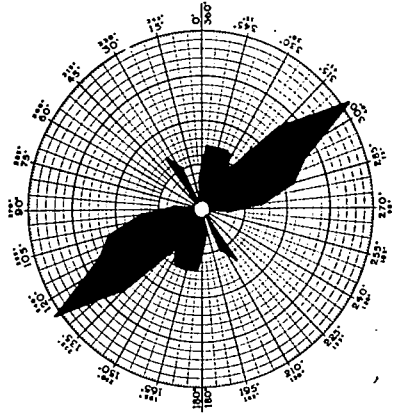


Fig. 6.1

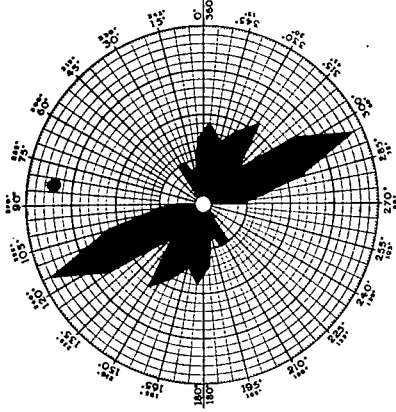
19.



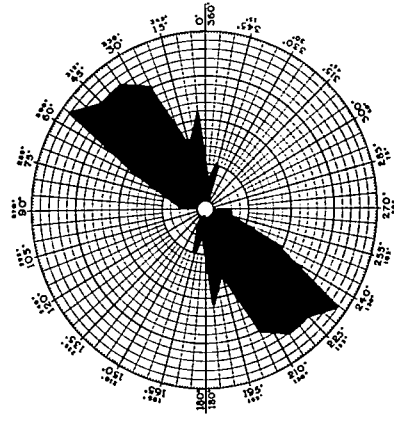
20.



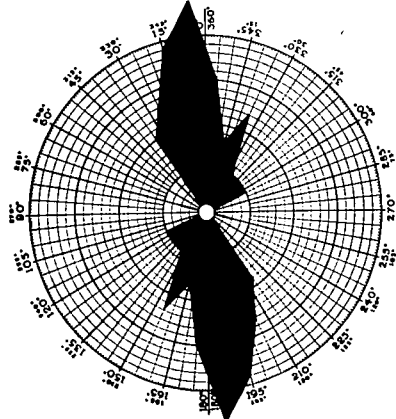
21.



22.



23.



24.

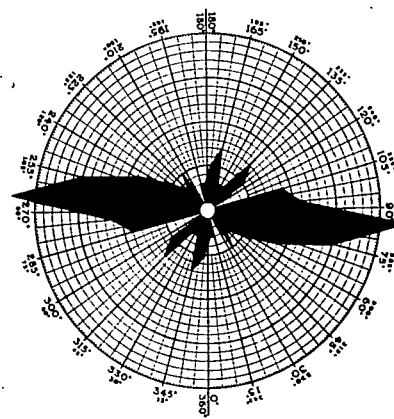
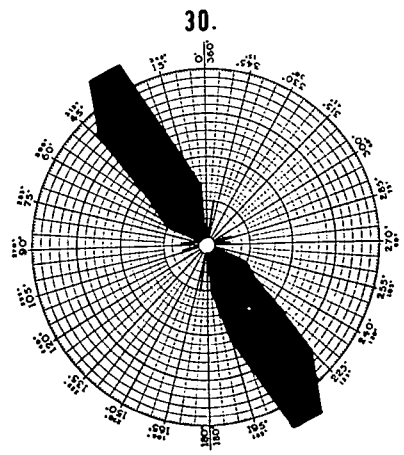
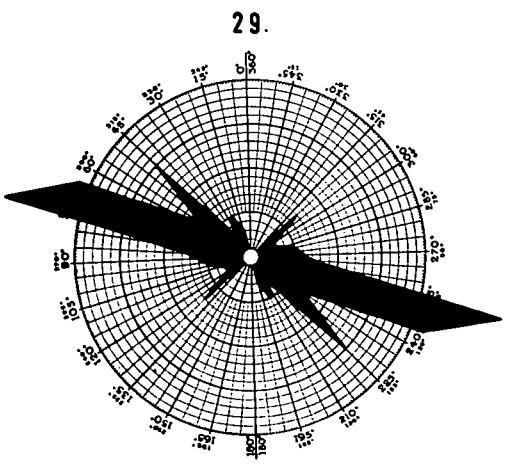
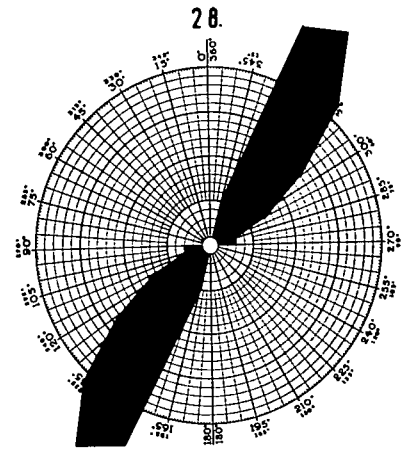
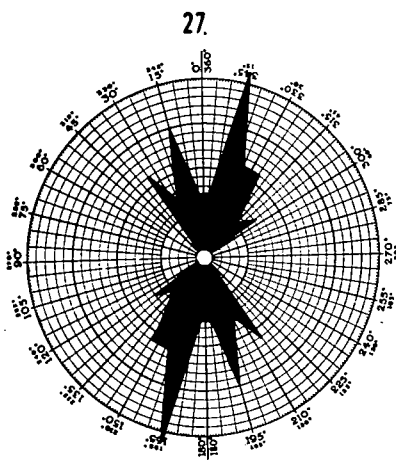
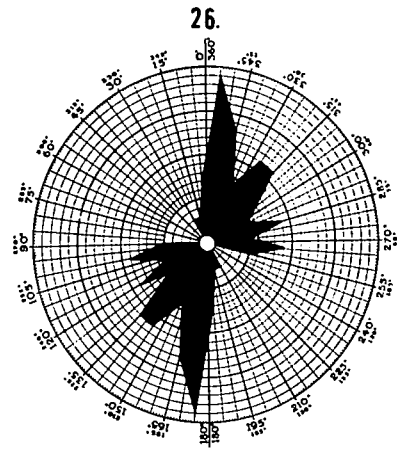
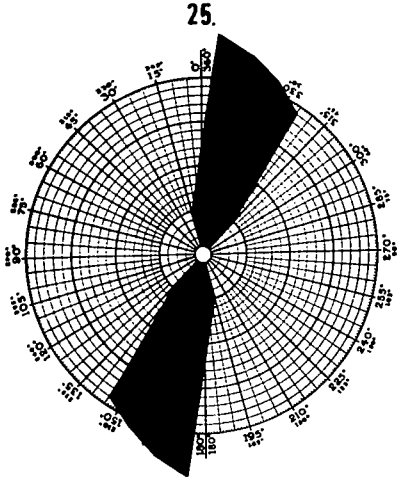


Fig. 6.1



Holmes (1941, p.1308) stated:

".....the statistical results showed that 50 stones generally suffice to indicate the preferred axial directions".

More recently King (1966, p.75) reached similar conclusions. Some most useful experimental work on this problem was the subject of a paper by Andrews and Ingle Smith (1966). Fabrics obtained from nine sites on the north-east coast of Yorkshire were compared statistically to assess the effect of sample size on the resultant direction. Theystate (p.35):

"There seems to be little rationale in relying on the apparently magic figure of 100 pebbles at each site. Support for this statement is given by the 20 values for N equal to 25, 50 or 100 which show no marked decrease in the confidence cone with increasing sample size".

Beaumont (1967) also stated that direction of ice movement at several sites analysed in Co. Durham could be estimated with reasonable accuracy from as few as 25 observations.

It would appear, therefore, that reliable results may be obtained by using relatively few observations at each site. The only disadvantage of using small numbers of observations is that as the number of observations decreases the standard error of the sample mean increases and therefore estimated of the true population mean become wider. The results of Andrews and Ingle Smith suggest that this is, however, not a significant increase within the range  $N = 25$  to 100.

Many workers have been content to judge, visually, the significance of their diagrams. Such assessments were probably induced by the great deal of time and effort required to analyse each diagram statistically. However, with the advent of computer techniques there seems little reason for avoiding such analyses.

Quantitative analysis of orientation patterns is useful in two respects. Firstly, it is necessary to prove whether or not the pattern of orientations is random. Secondly, an objective assessment of the resultant orientation is required. It is not adequate to rely on visual assessment alone.

Two simple quantitative methods which may be applied to rose diagrams are the calculation of the mode and arithmetic mean. The modal value may be readily seen from the histogram data and Krumbein (1939) has suggested that since a till may have been deposited under a set number of conditions then it would be expected that most pebbles would conform to these set conditions. The modal value, however, has the disadvantage in that no further statistical calculations can be made from it. Modal values for the thirty stone orientations completed by the writer are shown in Table 6.1. Calculation of the mean value is more laborious. Krumbein (1939, p.690) has described a method for obtaining the mean value for orientation data. From the mean value it is possible to calculate the standard deviation which is an estimate of the spread of the data about the mean. Potter and Pettijohn (1963, p.264) point out that the arithmetic mean can be a very poor measure of central tendency, especially if the data are widely dispersed. Categorically they state that (p.264):

"The best procedure always is to compute the vector mean".

The vector method of analysis was probably first used on orientation data by Reiche, P. (1938) and has subsequently been applied to a wide range of geological problems. Only recently, however, has the method been applied to till fabric analysis.

In vector analysis each observation is considered a vector with a direction and magnitude. The magnitude is generally considered as unity. The north-south and east-west components of each vector are computed by multiplying the magnitude by the cosine and sine of the azimuth, respectively. These components are summed to give the components of the resultant vector, which has a direction and a magnitude. The resultant vector ranges in value from 0 to the sample size used, such that a value of 0 would indicate a completely random distribution, while a value the same as the sample size would indicate that all the vectors are congruent. The resultant orientation is expressed as a trigonometrical function.

Such a vector method has several advantages over the calculation of the mean and standard deviation where the data are treated as a linear normal distribution. One difficulty which arises in such an assumption is the necessity of choosing an origin in order to divide a circular into a

linear frequency curve. A vector method of analysis avoids this difficulty because the descriptive statistics used for preferred orientation, direction and dispersion are independent of origin (Potter and Pettijohn 1963, p.264).

Vector methods are able to provide a powerful test of significance with which to test the randomness of the orientation pattern. Durand and Greenwood (1958) described the Rayleigh Test which tests the uniformity of the distribution. In practice it is possible to determine whether or not, at a given level of probability, a resultant vector could have arisen by chance.

The Rayleigh Test has advantages over the Chi-square test, which is often used to test the randomness of distributions. Curray (1956, p.125) in describing the Chi-square test stated:

"The disadvantage of this test is that deviations from randomness which produce a significant result do not necessarily represent a preferred orientation".

Thirty fabrics were analysed using the vector method. All analyses were performed on an IBM 360/1130 computer using a Fortran programme written by Thomas (1968). The results are shown in Table 6.1. Computer output included the resultant vector, resultant orientation, five and one per cent confidence limits.

Values of significance for the resultant vector using the Rayleigh test were obtained from Greenwood, J. A. and Durand, D. (1955). With a sample size of 50 the minimum values for acceptance of the distribution being non random under the null hypothesis are:

N (50)	95% probability level	12.5
N (50)	99% probability level	15.6

It may be concluded that all the orientation analyses show a significant preferred orientation (Table 6.1).

ii. An interpretation of the regional ice movement as determined by the fabric pattern.

The results of the fabric analyses are shown diagrammatically in Fig. 6.2. In all cases it has been possible to indicate the direction of ice movement for each orientation. Information on the presence of erratics

Table 6.1. Results of Two Dimensional Fabric Analysis.

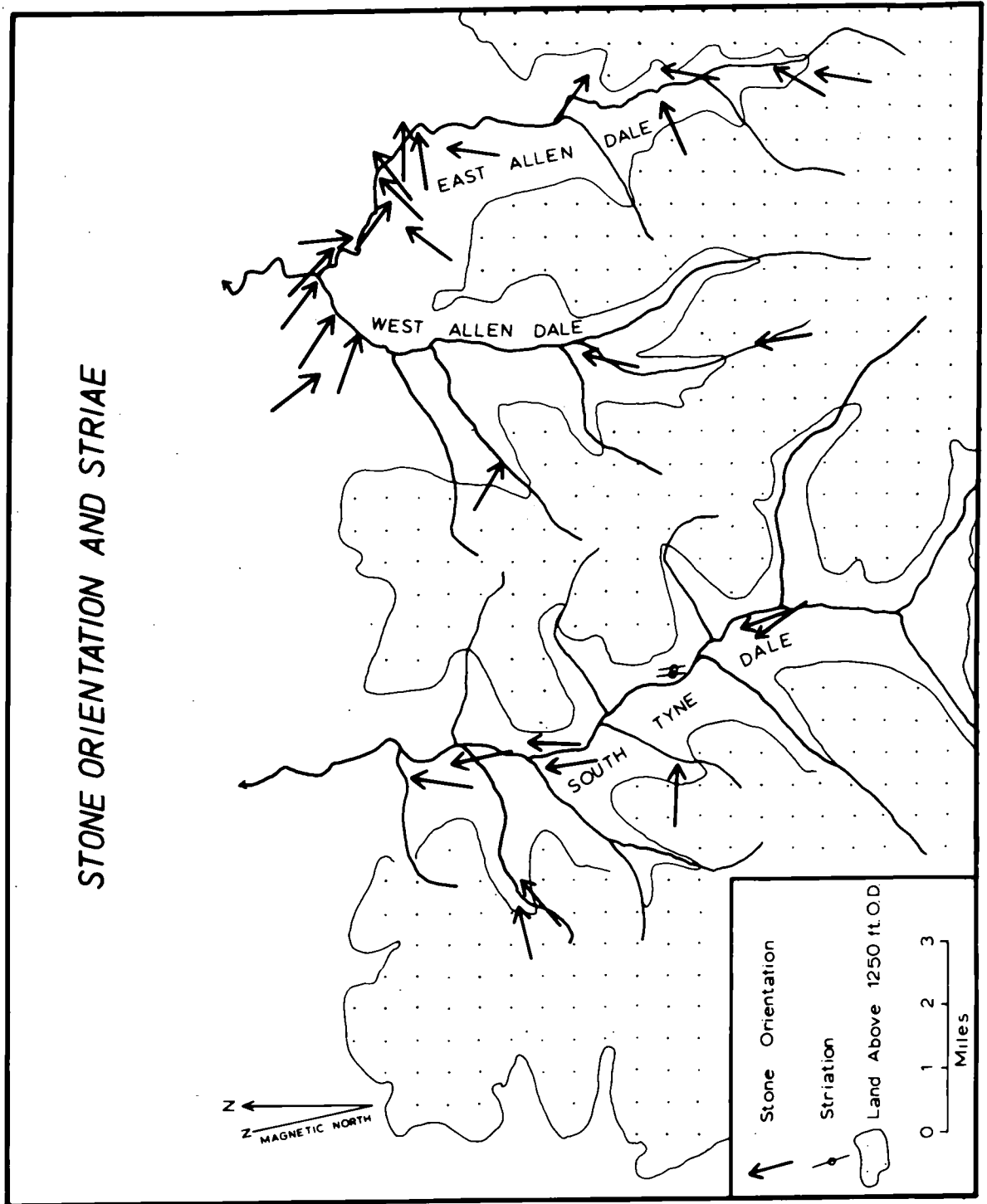
Orientation number and map reference.	Res. Vector.	Res. Orientation (in degrees)	5% Conf. Cone (To nearest degree)	1% Conf. Cone	Mid-point of 10° Modal Sector.
1.674565	46.1	26	6	8	25
2.675532	47.9	1	4	5	165
3.646536	48.7	60	3	5	55
4.640537	46.7	85	5	7	85
5.677555	44.6	173	7	9	165
6.679497	47.5	126	5	6	125
7.684532	47.5	16	5	6	15
8.714469	43.8	130	8	10	145
9.791582	46.6	136	6	7	145
10.713472	44.4	3	7	9	5
11.778522	43.9	18	8	9	15
12.757542	45.2	162	7	8	165
13.785577	47.6	125	4	6	135
14.780474	47.6	175	4	6	175
15.777586	45.2	5	7	8	5
16.844523	44.6	173	5	6	5
17.844500	43.9	71	8	10	75
18.845499	38.1	83	11	14	95
19.801588	43.8	131	8	10	135
20.826573	40.4	49	10	12	65
21.812565	42.9	36	8	10	65
22.806583	45.6	145	6	8	125
23.832556	44.6	177	7	9	175
24.837562	37.9	79	11	14	95



Cont. Table 6.1. Results of Two Dimensional Fabric Analysis.

Orientation number and map reference.	Res. Vector.	Res. Orientation (in degrees)	5% Conf. Cone (To nearest degree)	1% Conf. Cone	Mid-point of 10° Modal Sector.
25.849459	47.9	18	5	6	5
26.828568	40.2	32	6	12	5
27.810575	42.6	10	8	10	10
28.852471	48.3	39	4	5	35
29.828566	44.4	104	7	9	105
30.819569	44.8	139	7	9	145, 155

Fig. 6.2



and ice directions as indicated by meltwater channels proved useful in this respect.

In an upland area such as the Alston Block several difficulties are encountered when interpreting regional ice patterns from stone orientations. Firstly, the problem arises as to whether or not the till is in situ; it is always possible that a fabric may be the result of solifluction activity. The problem, however, is not wholly insurmountable if the orientation of the ground slope is measured. A fabric which has been soliflucted will show a preferred orientation parallel to the slope down which it has been soliflucted. The validity of any orientation may be assessed by taking this factor into account. A second difficulty is that where an ice-sheet is transgressing irregular relief it is likely that individual orientations may vary somewhat from the overall pattern due to the local control of relief on basal ice movements. Clearly the problem is one of scale. While our knowledge of till fabric genesis remains limited it is suggested that our interest be focussed on general patterns rather than specific detail.

The results of fabric studies in the South Tyne and its tributary valleys confirm the nature of the ice-gradients indicated by meltwater channels. Orientations on the high western flanks of the South Tyne valley indicate that ice was, at some stage of the glaciation, overriding the watershed bringing with it erratic material from the Vale of Eden and beyond (Fig. 6.2).

Oposing this general east-west pattern of ice movement are a number of fabrics in the South Tyne valley (Fig. 6.2). These fabrics would seem to indicate the movement of ice down the South Tyne towards the Tyne Gap.

Two broad patterns of ice movement are indicated from analyses in the East and West Allen Dales. In the southern part of the catchment fabrics indicate ice moving down valley from a southerly and south-south-westerly direction. Such a direction is in agreement with ice-gradients indicated by meltwater channels in the area.

In the lower reaches of the Allendales, particularly around their confluence, several fabrics indicate ice movement from the north-west. Stone counts also indicate a westerly provenance for these tills.

The results of these fabric studies are in no way considered proof in themselves of ice direction in the north-west Alston Block. They are, however, considered as useful complementary evidence of ice direction.

Reliance on any single technique may well be foolhardy when trying to reconstruct the nature of the glacial environment renowned for its complexities.

#### B. Striae.

Flint, R. F. (1957, p. 56) has described striae as:

"The most common and conspicuous unit of glacial abrasion is the striation (stria or scratch)".

Striae may have only a limited use in determining directions of ice movement. As Flint (1957, p.58) pointed out:

"In the majority of instances the actual direction of ice flow is not determined, and is not determinable, from evidence furnished by the striation itself; it is inferred from other features in the vicinity".

In any glaciated region striations are not uniformly distributed throughout the area. Many factors, such as Post-glacial weathering, lithology, concealment beneath drift cover and debris content of the ice, may affect their distribution.

Beaumont, P. (1967, p.72) suggested that the most favourable lithologies for the preservation of striae in the north-east of England are the limestones of the Lower Carboniferous followed by the Whin Sill dolerite and the various sandstone formations. All these lithological types occur in the north-east Alston Block.

Very few observations on striae have been observed in the Alston Block. Dwerryhouse (1902) has made the most complete description of striae in the northern Pennines and records striae in Weardale (Dwerryhouse 1902, p. 593) and Teesdale (p. 582). As far as the writer is aware no observations have been made of striae to date in the north-west Alston Block other than the two observations presented in this thesis. Apart from variable observations it is very probable that Post-glacial weathering, especially on exposed limestone surfaces, has removed much of the evidence.

Two sets of striae have been found on a freshly exposed limestone surface in the South Tyne valley. Both sets of striae were scratched into the surface of the Great Limestone, which is exposed at 683522, half a mile south-east of Slaggyford. The mean orientations of the two sets, measured with a prismatic compass, were 160 degrees and 175 degrees respectively. These striae would seem to indicate ice movement along the axis of the South Tyne valley.

Although each likely striae location was carefully searched no further striae observations were noted during two field seasons. Possibly in an area with heavy rainfall such as the Alston Block the majority of the striae, which are engraved on limestones, are rapidly removed by weathering.

#### Conclusions.

The results of stone orientation analyses have proven most useful in indicating the general lines of movement of ice during the last glaciation. They have shown that four main movements occurred. Firstly, at several sites stone orientations have indicated a west-east movement of ice across the Cross Fell-Cold Fell watershed into the South Tyne and Allendale valleys. A second set of orientation indicate that ice pouring through the Tyne Gap rode up onto the Alston Block and crossed the lower reaches of the East and West Allen Dales in a north-west south-east direction. A third set of fabrics at the head of the West and East Allen valleys indicates that ice moved into these valleys from a source region in the south-west, in the Cross Fell area.

Finally several fabrics in the South Tyne valley indicate that at some stage in the glaciation the valley was occupied by a valley glacier moving away from the higher ground of the Pennine uplands northwards to the Tyne Gap.

## Chapter 7.

### Stone Counts.

#### Introduction.

The determination of the frequency of rock types in till deposits by means of stone counts has long been practiced, particularly in Scandinavia (Lundqvist 1935), and the method was probably described for the first time by Ussing and Madsen (1897).

Although some workers in northern England qualitatively assessed the nature of the lithologies to distinguish tills of different provenance (Howse 1864, Kendal 1902 and Dwerryhouse 1902) little quantitative analysis has been done. Herdman (1909), who worked on the deposits of the Derwent valley, and Trechmann (1915) who analysed one stone count of 500 pebbles from the Scandinavian drift at Warren House Gill were the first workers to analyse the total lithology of till samples. Trotter (1929a) frequently recorded percentages of erratic material but made no attempt to study the total assemblage of lithological types present in the till.

More recently Beaumont (1967) has studied the pebble lithologies of the till sheets of lowland Durham. Beaumont's studies acted as a complementary technique in the study of provenance and also indicated many interesting features of till evolution.

Stone counts have proved useful in differentiating till sheets (Dreimanis and Reavely 1953; Jarnefors 1952; Kruger 1962 and Beaumont 1967), and for solving problems associated with till deposition (Okko 1941, 1945; Gillberg 1955). Some workers have also used this method in studies of till dispersal systems (Krumbein 1937; Holmes 1952; Beaumont 1967 and Gillberg 1968).

No detailed study of the pebble lithology has been previously undertaken in the north-west Alston Block. In this context 52 till samples were analysed in the hope that they would be useful in a study of a) provenance of the till, and b) provide raw data for a study of the till dispersal.

Although most attention has been paid to the detailed stone counts performed in the laboratory the writer also carefully examined each exposure noting the general abundance of each rock type. This provided a useful check on the results of the stone counts indicated below.

#### Methods of Analysis.

Several methods of analysing the lithology of glacial till have been used. Lundqvist (1935, 1940) counted surface material and attained useful results concerning the relationships between boulder trains and topography. Okko (1941, 1945) in his studies in Finland also used the same method and discovered that the surface material was not always of the same petrographic composition as the underlying till. To overcome this problem Lag (1948) dug out stones from the face of the till exposure. Although this method assured the worker that he was dealing directly with the deposit it remained rather a subjective method in that a certain amount of selectivity was inevitable.

A more objective method was described by Dreimanis and Reavely (1952) in a study of the Lower and Upper till sheets along the north shore of Lake Erie. Large samples of till were taken back to the laboratory and the rock fragments, ranging from 4.6 mm. to 8 cm. in diameter were used for pebble counts.

Dreimanis and Reavely pointed out that in order to obtain enough pebbles for analysis up to 150 lbs. of till per sample is required and furthermore they indicated that to separate the pebbles from this sample was a long and arduous procedure. The merit of this method is that, due to the relatively large size of the pebbles, accurate determination of provenance was often possible.

For several reasons the present writer did not adopt the method of Dreimanis and Reavely. The nature of the terrain, with its incised valleys and lack of suitable tracks inhibited the use of a vehicle which would have been necessary to carry such quantities of samples as demanded by Dreimanis and Reavely. Furthermore, such large samples require a great deal of storage space, space which was not available to the present worker.

The method of analysis used by Beaumont (1967) proved a useful solution to this problem. This method, which may be termed a micro-stone count, uses material from the initial 2000 gram sample which also served for particle size analysis (Chapter 8). The method of sampling is random and volumetric and is, therefore, not selective. The stones used in the count are those retained on the  $\frac{1}{2}$ ",  $\frac{3}{8}$ ",  $\frac{1}{4}$ ",  $\frac{3}{16}$ " and  $\frac{1}{8}$ " diameter sieves during the dry sieving stage of particle size analysis (Chapter 8). No special preparation of the sample is therefore necessary and this must be regarded as a distinct advantage. Enough stones can be obtained from each 2000 gram sample for the analysis to be representative.

The small size of many of the stones examined made it impossible to locate their provenance accurately. In many cases this would also have necessitated cutting thin sections which would have greatly added to the time of each analysis. To overcome this difficulty it was decided to classify the stones found in the till into lithological groups. The following classification of nine lithological types was used:

1. Sandstone.
2. Shale/mudstone.
3. Coal.
4. Quartzite.
5. Paleozoic Grits.
6. Igneous/metamorphic.
7. Permo/Triassic sandstones.
8. Limestone.
9. Others.

In terms of the present analyses such a simplification has little, if any, disadvantage. The country rock of the north-west Pennines is almost entirely composed of Carboniferous sediments although limited outcrops of Whin Sill also occur. Palaeozoic grits, igneous/metamorphic material or Permo/Triassic sandstone are known, therefore, to be erratics. There seemed little point in studying the provenance of the erratic material in more detail, at least not until the complexities of ice movement in Edenside have been worked out in detail. It is known that both Scottish and Lake District erratics occur in Edenside and the presence of such erratics in the



tills of the Alston Block would, therefore, not necessarily imply any direct provenance from either of these two sources.

Using a binocular microscope it was relatively easy to classify each stone. In addition dilute hydrochloric acid provided a definitive test for Carboniferous limestone. The number of stones counted varied depending on the number retained on the sieves. No stone count contained less than 200 stones and the vast majority contained counts of more than 400.

In a series of test counts on the tills of lowland Durham, Beaumont (1967) concluded that a count of only 100 stones produced a reliable guide to the total assemblage of lithologies while counts of 200 were regarded as being a very good indication of the total lithological composition of the till. After some practice the writer found it possible to count all the stones retained by the sieves for each sample in three or four hours. The results of 52 stone counts of till samples from the north-west Alston Block are shown in Table 7.1.

#### Results of Stone Count Analyses.

The results of these analyses are most easily described if the results for the South Tyne catchment and the Allendale valleys are considered separately. Figure 7.1 shows the location of the 52 sampling sites. The sites are labelled in a similar manner to the data in Table 7.1 for easy reference.

1. South Tyne Catchment.
- a. The Gelt, Knar and Thornhope Burns.

Five stone counts were completed for these three tributary valleys (Fig. 7.1, sites 13, 31, 43, 44 and 45). Stone counts in the Knar and Gelt Burns are characterised by the presence of erratic material indicating a westerly provenance. At site 43, for instance, in the Knar Burn there is some 0.9% Palaeozoic grit, 4.3% igneous and metamorphic types, and 3.7% Permo/Triassic sandstone. These findings are in accord with those of Hollingworth (1932) who described Scottish and Lake District granites from these two valleys. The height of the watershed to the west of the Gelt and Knar Burn rises to more than 1900 feet O.D. in many places (Fig. 1.2).

Table 7.1. Results of Stone Count Analysis.

Samples (results in %)	1	2	3	4	5	6	7	8	9	10
Lithology										
Sandstone	55.9	63.9	24.6	29.2	75.4	76.3	60.8	66.5	31.4	60.1
Shale/Mudstone	42.9	35.1	52.3	3.6	22.6	23.6	33.7	28.1	2.9	38.6
Coal	-	0.7	0.3	-	-	-	-	-	-	0.1
Quartzite	0.4	-	-	-	-	-	-	0.1	-	-
Palaeozoic Grit	-	-	-	-	-	-	0.3	-	12.5	-
Igneous/Metamorphic	0.4	-	-	-	-	-	3.1	0.1	30.4	0.7
Permo/Triassic sst.	0.4	-	-	-	-	-	-	-	22.5	0.3
Limestone	-	0.2	22.6	67.1	1.9	-	1.9	4.9	-	-
Others	0.3	0.1	0.2	0.1	0.1	0.1	0.2	0.3	0.3	0.2
Total number of stone counted	642	410	787	907	783	292	258	768	470	655
Sample locations: (Ordnance survey map references - 1" sheets, 76 77, 83 and 84).	1, 776586	2, 852471	6, 667566	7, 838562	8, 846542	9, 675555	10, 802586			

Cont. Table 7.1. Results of Stone Count Analysis.

Samples (results in %)	11	12	13	14	15	16	17	18	19	20
<b>Lithology</b>										
Sandstone	73.7	54.5	71.6	41.0	57.1	57.4	55.3	80.0	75.0	53.7
Shale/Mudstone	20.0	40.4	12.9	48.3	41.2	25.5	43.0	11.1	20.4	36.3
Coal	0.2	0.8	0.3	-	-	0.1	0.3	0.2	0.3	0.1
Quartzite	0.2	0.2	0.8	0.15	0.1	0.8	0.2	1.1	-	0.2
Palaeozoic Grit	0.2	1.0	3.3	-	-	2.4	0.2	0.2	-	4.8
Igneous/Metamorphic	0.1	1.1	7.4	-	-	5.0	0.5	2.0	-	3.6
Permo/Triassic sst.	0.1	0.7	0.17	-	-	2.4	0.2	0.2	-	0.7
Limestone	5.0	1.0	1.4	10.6	1.3	5.6	-	3.7	3.8	-
Others	0.5	0.3	2.4	-	0.3	0.8	0.3	1.5	0.5	0.6
Total number of stones counted	827	787	565	641	647	696	783	350	572	679
Sample locations:	11. 837506	12. 809575	13. 678532	14. 755543	15. 783578	16. 845500	17. 779578	18. 826571	19. 799490	20. 828568

Contd. Table 7.1. Results of Stone Count Analysis.

Samples (results in %)	21	22	23	24	25	26	27	28	29	30
Lithology										
Sandstone	60.3	51.9	56.1	51.6	57.0	73.1	46.8	45.4	47.8	55.8
Shale/Mudstone	36.7	0.1	36.2	42.7	28.9	20.2	47.0	53.4	36.1	38.7
Coal	-	-	-	-	-	0.6	0.5	-	0.3	0.1
Quartzite	0.8	-	-	0.1	-	0.1	0.1	0.3	1.3	0.1
Palaeozoic Grit	0.8	-	-	-	1.5	0.6	-	0.1	-	-
Igneous/Metamorphic	0.8	-	-	-	5.6	1.6	-	0.4	-	-
Permo/Triassic set.	-	-	-	-	1.7	-	-	-	-	-
Limestone	0.2	47.9	7.6	5.4	4.9	3.2	4.8	-	14.3	4.8
Others	0.2	0.1	0.1	0.2	0.4	0.6	0.8	0.4	0.2	0.5
Total number of stone counted	699	703	787	790	445	656	595	642	988	723
Sample locations:	21. 806583	26. 819569	22. 713473	27. 845499	23. 780474	28. 785587	24. 828568	29. 684532	25. 832514	30. 779558

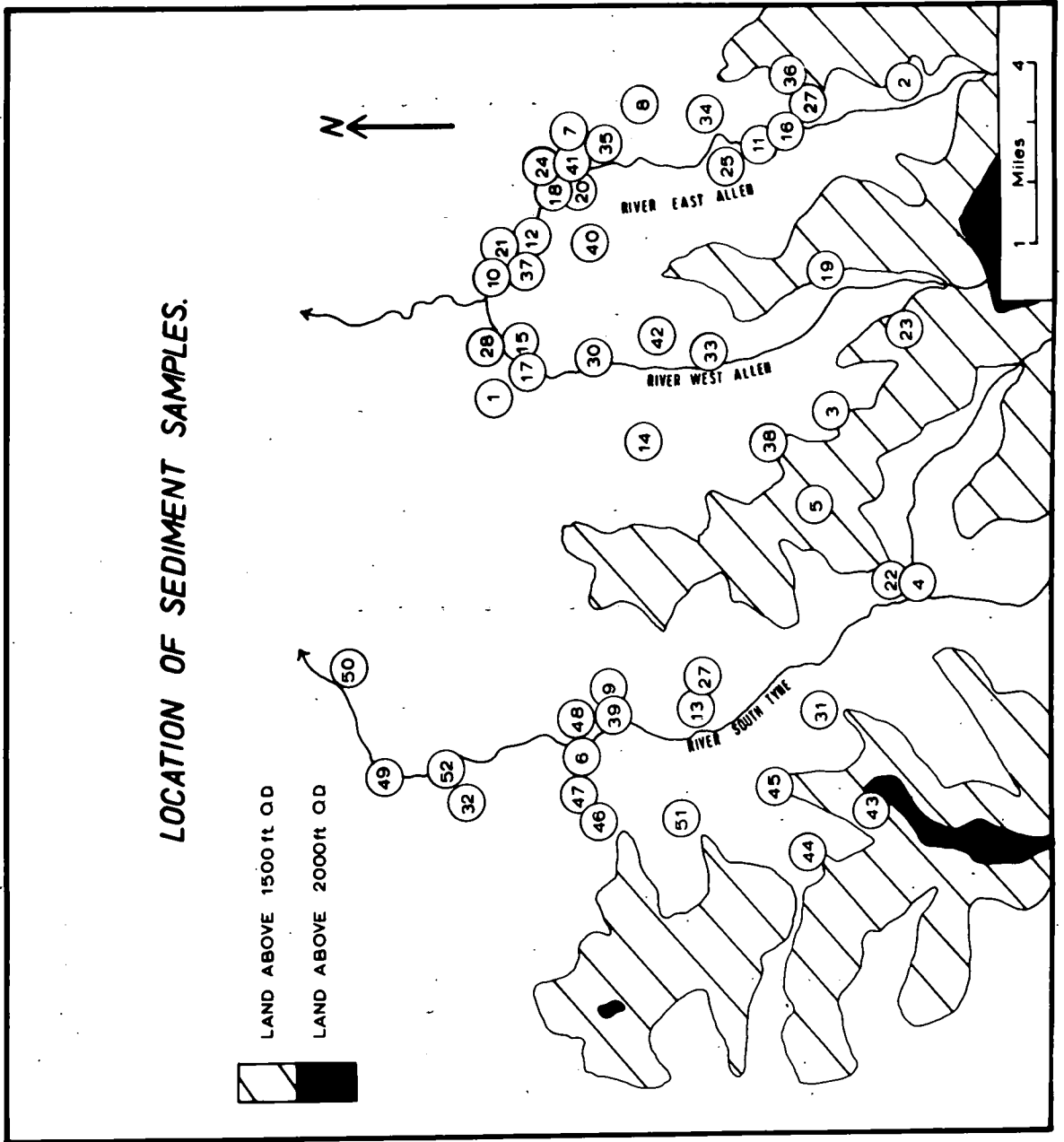
Contd. Table 7.1. Results of Stone Count Analysis.

Samples (results in %)	31	32	33	34	35	36	37	38	39	40
Lithology										
Sandstone	40.7	28.3	52.8	54.2	64.8	50.9	85.0	41.4	43.6	61.8
Shale/Mudstone	59.1	7.6	33.9	41.8	29.3	47.4	5.4	37.4	53.0	29.9
Coal	-	0.6	-	-	0.5	0.2	0.3	-	-	0.1
Quartzite	-	1.0	0.6	-	0.5	0.5	0.1	-	-	0.2
Palaeozoic Grit	-	22.0	-	-	-	-	0.8	-	-	-
Igneous/Metamorphic	-	25.3	-	-	0.1	-	1.9	-	0.6	-
Permo/Triassic sst.	-	10.1	-	-	-	-	0.1	-	-	-
Limestone	-	2.0	12.0	3.2	4.2	0.5	5.4	19.6	2.3	7.0
Others	0.2	3.1	0.7	0.8	0.6	0.5	1.0	1.6	0.5	1.0
Total number of stone counted	906	494	666	853	586	377	569	403	759	904
Sample locations:										
	31.	679497	36.	850499						
	32.	652598	37.	805575						
	33.	778522	38.	753508						
	34.	843522	39.	677555						
	35.	834554	40.	809555						

Contd. Table 7.1. Results of Stone Count Analysis.

Samples (results in %)	41	42	43	44	45	46	47	48	49	50	51	52
Lithology												
Sandstone	67.7	59.4	56.0	31.0	51.8	93.2	32.1	81.7	38.1	10.8	85.6	47.8
Shale/Mudstone	23.6	16.1	34.4	54.3	39.3	6.3	67.5	15.6	13.3	2.6	13.9	24.2
Coal	0.1	-	-	3.2	0.2	-	0.2	-	0.7	0.3	0.4	3.4
Quartzite	-	-	-	1.8	0.4	0.2	-	-	0.1	0.3	-	-
Palaeozoic Grit	0.7	-	0.9	-	0.2	-	-	0.1	12.8	22.6	-	5.5
Igneous/Metamorphic	0.6	-	4.3	6.2	1.6	-	-	2.0	22.1	61.0	-	10.7
Permo/Triassic sst.	-	-	3.7	-	0.2	-	-	0.3	4.0	1.2	-	4.1
Limestone	-	23.1	0.6	1.8	5.8	-	-	-	8.5	-	-	3.9
Others	7.3	1.4	0.1	1.7	0.5	0.2	0.2	0.3	0.4	1.2	0.1	0.4
Total number of stone counted	677	601	325	274	478	456	364	620	561	998	431	840
Sample locations:	41. 832556	42. 782539	43. 648480	44. 634503	45. 658510	46. 647560	47. 655565	48. 676566	49. 664620	50. 695629	51. 646536	52. 664602

Fig. 7.1



29 JAN 1960

The presence of erratic material in the stone counts would seem to indicate that at some stage of the glaciation ice from Edenside was able to cross over this high watershed. Surprisingly, the stone counts at locations 43, 44 and 45 (Fig. 7.1) revealed that only a very small percentage of the total lithology, within the size range being considered, was Permo/Triassic in derivation. At sites 43, 44 and 45, the percentages were 3.7, 0.0 and 0.2 respectively. The nearest outcrops of Permo/Triassic material lies only a short distance to the west of the Pennine watershed. Two points would seem to emerge from the five stone counts in the Knar and Gelt Burns. Firstly, ice from Edenside must have been relatively erosive as it crossed the Pennine escarpment. After only a short distance (6 or 7 miles) the erratic content is reduced to less than 9 per cent. Secondly, the stone counts indicate ~~that~~ the relatively friable <sup>nature of</sup> Permo/Triassic sandstone.

Sample 31 from the Thornhope valley (Fig. 7.1, Table 7.1) consisted entirely of local material. Hollingworth (1932) indicated that erratic material was very rare in the Thornhope Burn but offered no explanation to account for this anomaly. To the south-west the Thornhope Burn is bounded by a high watershed rising at several points to over 2000 feet O.D. (Fig. 1.2). Running north-eastwards from this watershed is a high spur which effectively separates the Thornhope Burn from the Gelt and Knar Burns (Fig. 1.2). This spur might have been an important barrier to ice movement from the Gelt and Knar Burns into the Thornhope Burn.

b. Thinhope and Glendue Burns.

Four samples were analysed from the Thinhope and Glendue Burns (Fig. 7.1, nos. 6, 46, 47 and 51). The stone counts indicate that the tills of these two valleys are of local origin, no erratic material being present. Hollingworth (1932) suggested that north of Great Blacklaw Hill (622534) the Pennine watershed was not overridden by ice from Edenside. The stone counts from the Thinhope and Glendue Burns confirm Hollingworth's opinion.

c. Ayle Burn.

One sample of till was analysed from the upper Ayle Burn (Fig. 7.1 no. 5). The object of this analysis was to confirm the field evidence collected by the writer which suggested that this area was last subject to inundation by ice from the Cross Fell area. The stone count confirmed this



view and indicates a local provenance for the till in this valley (Table 7.1).

d. The Upper South Tyne Valley.

Six stone counts were undertaken of till samples from the upper section of the South Tyne within the writer's field area (Fig. 7.1, nos. 4, 9, 22, 29, 39 and 48). With the exception of sample no. 9 these tills are characterised by the general absence of erratic material. From field evidence they are thought to have been formed by a valley glacier which, at some stage of the glaciation occupied the South Tyne valley.

Casual observation in the field suggested that the till appeared to contain more limestone as it was traced southwards down valley. At this point it will be obvious that quantitative stone counts are most useful for it was possible to test this subjective field assessment and also to measure in a quantitative fashion the relative change in lithology that seemed to be taking place. The percentages of limestone in five of the till samples (nos. 4, 22, 29, 39 and 48) were plotted against distance on semi-logarithmic graph paper (Fig. 7.2). It is immediately apparent that a meaningful relationship exists between these two variables and that the lithological change took place in some ordered fashion.

Sample no. 4, containing some 67 per cent limestone (Table 7.1) is located just down stream of an outcrop of the Great Limestone which was rapidly incorporated into the till as the ice passed over its outcrop.

Several workers have made similar studies of glacial dispersion from a point source (Krumbein 1937; Harrison 1960 and Gillberg 1967 and 1968). Krumbein (1937) found that boulders per unit area plotted against distance of transport followed the distribution function:

$$Y = Y_0 e^{-ax}$$

where Y is the concentration of boulders in a given area,  $Y_0$  the concentration in a given area at the source, a is a constant and x the distance of transport. Krumbein indicated that such an equation will plot as a straight line if the logarithm of the concentration (or percentage if based on pebble counts) is plotted against distance.

Down current decrease in concentration is due to progressive dispersion, to dilution and to abrasion, three independent processes which if they could be independently estimated could be expressed as:

$$Y_0 e^{- (a_1 + a_2 + a_3)x}$$

where  $a_1$ ,  $a_2$ ,  $a_3$  are constants for areal dispersion, dilution and abrasion and where  $a_1$ ,  $a_2$ ,  $a_3 = a$ . Similar negative exponential functions appear to characterise many dispersal systems (Potter and Pettijohn 1963).

A stone count at location no. 9 (Fig. 7.1 revealed that this sample contained some 65 per cent erratic material, 12.5 per cent being Palaeozoic grit, 30.4 per cent igneous and metamorphic rock types and 22.5 per cent Permo/Triassic. The presence of till with erratic material at sites in the South Tyne valley is not unexpected if the complexity of glacial events is considered. The relatively high percentages of Permo/Triassic material are rather more difficult to explain in view of the fact that at several sites to the west, nearer the source of such material, stone counts indicated much lower percentages of Permo/Triassic rock types. The stone counts, in this case merely point out the anomaly and offer little help in the way of explanation.

#### e. Lower South Tyne Valley.

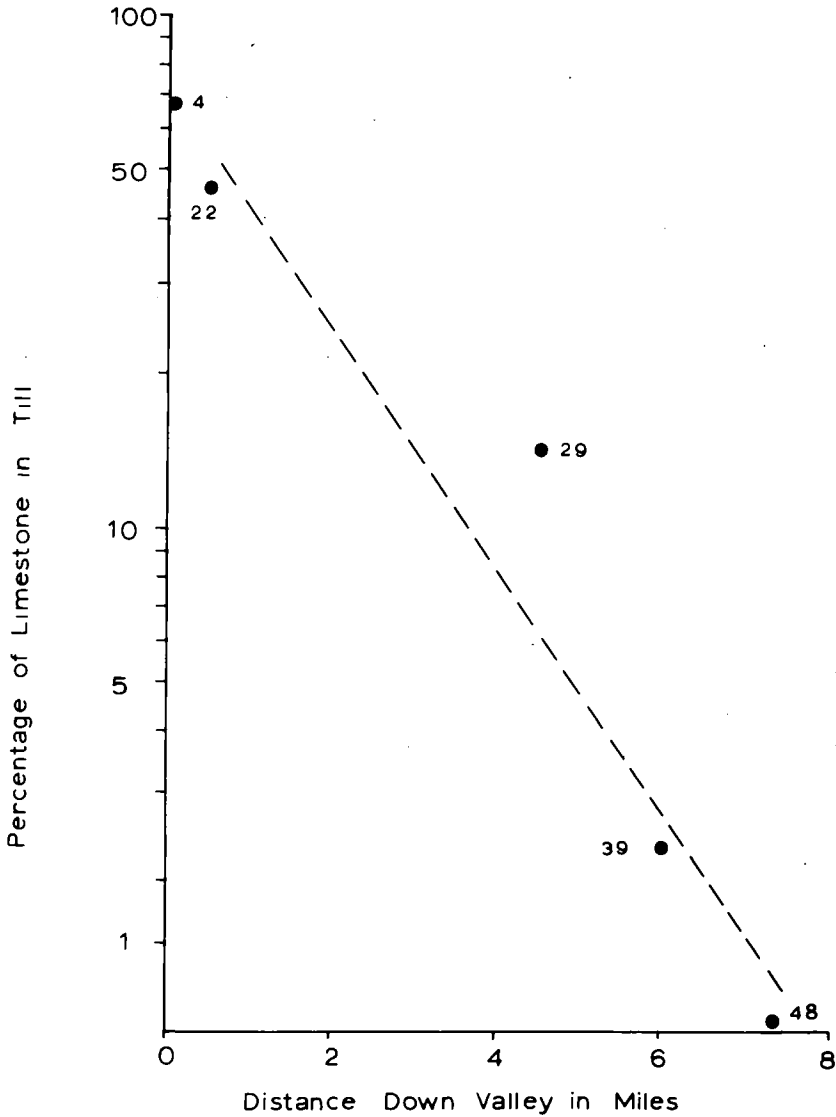
Four till samples were taken from the lower, more open reach of the South Tyne valley (Fig. 7.1, locations 32, 49, 50 and 52). As expected the percentages of erratic material is very high being 57.4, 38.9, 84.8 and 21.3 per cent at sites 32, 49, 50 and 52 respectively. Although these samples would be expected to contain relatively large percentages of Permo/Triassic material the stone counts indicated that, within the size range being studied, these four samples each had less than 11 per cent. It is very obvious from the reddish colour of these four samples that a great deal of Permo/Triassic material has been incorporated into the matrix of the till and one must presume that the low percentages of such material in the coarse fraction are due to rapid abrasion by very active ice.

#### 2. West Allen Dale.

Twelve samples of till were analysed from West Allen Dale (Fig. 7.1 nos. 1, 3, 14, 15, 17, 19, 23, 28, 39, 33, 38 and 42). From the stone counts

Fig. 7.2

RELATIONSHIP BETWEEN DISTANCE  
AND LIMESTONE CONTENT IN THE  
SOUTH TYNE VALLEY TILLS.



( ● 4, 22, 29, 39, 48 are sites referred to in text. )

(Table 7.1) it is clear that the majority of these till samples are of Pennine provenance. The southerly group of samples (nos. 3, 14, 19, 23, 30, 33, 38 and 42) do not contain erratic material. The lack of such erratic material is explained when reference is made to the probable direction of ice that deposited this till. Both the direction of meltwater channels and stone orientations suggest that the upper parts of the West Allen Dale were inundated by ice which issued from the Cross Fell region into the heads of the South Tyne, West and East Allen Dales.

The lack of erratic material is corroborated by the writer's field work. A great many exposures were examined in the course of two seasons' field work but no erratic material was found in the West Allen Dale up stream of Whitefield Hall (778568).

Of the four remaining samples taken from West Allen Dale three contained small amounts of erratic material indicating a westerly provenance. The percentages were 0.8, 0.9 and 0.5 per cent at locations 1, 17 and 28 (Fig. 7.1) respectively.

It is not intended here to develop the arguments for and against the probable directions of ice movement in the West Allen Dale but two points worthy of mention emerge from the stone counts.

First, it is obvious that Derryhouse (1902) was wrong to think that the upper part of West Allen Dale was not glaciated. If this were the case the till examined at sites 23, 3, 19 (Fig. 7.1) would be difficult to explain. Secondly, it is difficult to accept totally Trotter's view (1929a) that local ice, flowing northwards down the West Allen valley, was, at the maximum glaciation, overridden by ice, carrying with it erratic material, moving from west to east. The failure of the present investigator to find any erratic material, which should be very evident if such superimposition took place, militates against Trotter's view and an alternative hypothesis is sought.

### 3. East Allen Dale.

19 samples were analysed from East Allen Dale. Several of the samples from the lower reaches of the River Allen contained erratic material indicating a westerly provenance. The majority of these samples contained less than 4 per cent erratic material (nos. 10, 21, 37, 12, 18, 24, 41, 7

and 35). One sample (no. 20) did, however, contain 9 per cent erratics (Table 7.1) and had a distinct reddish colour in the field. Some ten yards down stream, in a bank exposure the till appeared much darker in colour and no erratic material was found. A stone count (Table 7.1, no. 24) of 790 stones failed to find any igneous material and it is concluded that sample no. 20 has a different provenance to sample no. 24.

A local till is also found at Hawksteel (Fig. 7.1, no. 40). It might have been expected that this till sample would have contained some erratic material. In Trotter's view (Trotter 1929a) this site would have been covered by ice of western provenance. A careful search in the vicinity of this site failed to locate any erratic material and the stone count offers supporting evidence for the local nature of this deposit.

Stone counts from samples in the upper part of the East Allen Valley also revealed unexpected results. Samples from three sites (Fig. 7.1, nos. 11, 16 and 25) contain erratic material, indeed samples 25 and 16 are seemingly rich in erratics compared with samples from further downstream. Samples 25 and 16 (Table 7.1) contained 8.8 and 9.8 per cent respectively. The presence of erratic material in the stone counts of these three samples is rather difficult to explain in view of the fact that till exposed in West Allen Dale (in an up ice-stream direction) appears to lack erratic lithologies. This point becomes very pertinent to the nature of glacial events and is considered further in Chapter 14.

The three most southerly stone counts, sites 2, 16 and 17 (Fig. 7.1) indicate that the till in the upper East Allen valley is of local origin. This agrees fully with other lines of evidence concerning ice movement in the East Allen Dale which indicate that ice from the south-west poured into the upper parts of East and West Allen Dale from the Cross Fell region.

### Conclusions.

Stone counts of a restricted but consistent size range, as presented here, provide a simple but effective measure of the lithology of glacial till. This chapter has been concerned basically with presenting the raw data of 52 such analyses. Such data provided useful evidence in studies of glacial provenance. A secondary benefit of such analysis is the provision of raw

data on aspects of lithological dispersion and rates of dilution that occur during till transport and where pertinent these two topics have been touched upon in the present chapter.

## Chapter 8.

### Particle Size Analysis.

#### Introduction.

Particle size analysis, or mechanical analysis, is but one of an increasing number of sedimentological techniques now being usefully employed in the field of geomorphology. Much of the early ground work of particle size analysis was laid down in the U.S.A. where such methods have for a long time been standard methods of analysis.

Broadly speaking particle size analysis has been used as an analytical tool by geomorphologists in three research fields. Firstly, it has been used as a correlative and ~~discriminative~~<sup>discriminative</sup> method. Among the earliest workers to use particle size analysis in this field was Udden (1898) who observed that the particle size of sediments varied considerably according to the type of sediment involved. These early observations have been elaborated by a great many later workers including Krumbein (1933); Maclintock (1933); Kruger (1937); White and Shepps (1952); Dreimanis and Reavely (1953); Knox (1953); Shepps (1953); Kaiser (1962) and Gillberg (1965).

Secondly, particle size analysis has been used to study weathering phenomena assuming that material is comminuted and translocated to lower horizons and thus producing an enrichment of fine material. Gravenor (1954); Brewer (1955); Goldthwaite (1959); Gooding, Thorpe and Gamble (1959), and Gooding and Gamble (1960).

Finally, many workers have concerned themselves with the interpretation of the results of particle size analyses and their generic implications. Krumbein (1934); Douglas (1946); Mason and Folk (1958); Fold and Ward (1957); Freidman (1962); Moss (1962a, 1962b); Spencer (1963) and Beaumont (1967).

Only recently have British geomorphologists come to recognise the value of mechanical analysis, although as early as 1916 Boswell had attempted particle size analysis of some East Anglian glacial deposits.

Its usefulness, partly as a descriptive tool and partly as an analytical technique, prompted the writer to undertake a detailed study of the particle size analysis of the tills of the north-western Alston Block. Much interesting work concerning the particle size analyses of tills has been done in lowland Durham by Beaumont (1967) and to some extent the writer's analyses represent a complementary study of tills deposited in the adjacent upland environment of the Alston Block. Also included in this chapter is a description of the lacustrine deposits found in East Allen Dale. Particle size evidence was sought to confirm their rhythmic nature.

#### Methods and Problems of Analysis.

A profound problem inherent in all mechanical analysis, and of particular importance in the analysis of glacial deposits, is the initial field sampling. Only a small part of the material in question can be removed and analysed. If generalisations are to be made from the obtained results it is, therefore, very important that the sample is representative and yet small enough to be manageable. The very nature of glacial tills, with material ranging in size from clay minerals to large boulders, adds to the problem.

The representativeness of a sample depends upon the size ranges being sampled. If a wide range of particle sizes are to be sampled then more sample is required than if, for instance, only one or two fine grades are to be analysed. Some help with this problem is given by the British Standards Institution who have calculated the size of sample required to express the true particle size characteristics of any deposit (B.S.1377). The results of their findings are listed below:

<u>Maximum Size of Material Present in Substantial Proportions</u>	<u>Minimum Weight of Sample to be taken for Sieving</u>	
<u>inches.</u>	<u>lbs.</u>	<u>Kg.</u>
2½	110	50
2	77	35
1½	33	15
1	11	5
¾	4.5	2



After an inspection of the above results it was decided to limit mechanical analysis to that material equal to and less than  $\frac{3}{4}$  inch in diameter. The collection of larger samples was inhibitive for two reasons. Firstly the enormous problems of storage and analysis of larger samples would have been difficult to overcome. Secondly, the nature of much of the sampling terrain would have made the collection of samples, other than those which could be easily carried, a most difficult task.

At each sample location four discrete random samples were obtained from unweathered till. The four samples were then combined so as to produce a composite sample of c.4 kilograms. All samples were collected in polythene bags to prevent the loss of fine material.

In the laboratory each composite sample was gently broken down by hand and passed through a  $\frac{3}{4}$ " British Standard sieve. The sample was then dried in an oven maintaining a temperature of 105-110° C. From this oven dried material a representative sample of 2000 grams for coarse particle size analysis was obtained with a riffle. A further sample of c. 1000 grams was gently broken up in a mortar using a rubber-tipped pestle and this material was passed through a No. 8 B.S. sieve. The material passing the No. 8 sieve was used for pipette and chemical analyses.

A total particle size range from 20 millimetres to 0.001 millimetres was analysed, wet and dry sieving methods being used for coarse analysis and a pipette for the silt and clay analysis. (Appendix 2).

The total amount of time involved in such analyses was considerable. The wet sieving of clayey tills, even after adequate dispersion, often required a great deal of time and patience. The total time taken to analyse a single sample from start to finish was of the order of 3 days.

### Results.

The choice of particle size categories remains somewhat arbitrary and is dependent to some extent on the type of equipment available. The present writer has used a nest of sieves recommended by the British Standards Institution (B.S. 1377, 1961) and their recommended grade categories. Other grade scales exist, such as the Wentworth scale and the phi scale, but these

require special sieves not available to the writer.

British Standards Institution grade scale is as follows:-

	<u>diameter in millimetres.</u>		
Cobbles	200.0	-	60.0
Coarse gravel	60.0	-	20.0
Medium gravel	20.0	-	6.0
Fine gravel	6.0	-	2.0
Coarse sand	2.0	-	0.6
Medium sand	0.6	-	0.2
Fine sand	0.2	-	0.06
Coarse silt	0.06	-	0.02
Medium silt	0.02	-	0.006
Fine silt	0.006	-	0.002
Clay	less than		0.002

Visual comparisons of particle size curves are difficult. The problem, however, has been simplified by assessment of three major, although arbitrary, size categories, namely:- sand, silt and clay. Graphic analysis of the sand, silt and clay percentages of a deposit indicates, in a simple way, the textural nature of the sample and allows easy comparison with other published data.

The results of fifty-two analyses of glacial till from sites in the north-west Alston Block are presented in Table 8.1 and plotted as histograms showing percentage sand, silt and clay respectively (Fig. 8.1). All three histograms appear to be approximately normal in distribution, suggestive of some tendency for the tills of the north-west Alston Block to be characterised by a specified range of percentages of sand, silt and clay.

Values for silt and clay sized material appears to be much more variable than those for sand which are relatively concentrated (Fig. 8.1). The silt size fraction has a modal concentration (33 per cent of all samples) in the class 40.50 per cent. Clay size material is highly concentrated in the 20.30 per cent range (50 per cent of all samples). Sand sized material shows the most marked concentration of values, over half the values lying in a single modal class from 30 to 40 per cent sand.

It is of interest to compare values obtained for tills in lowland Durham (Beaumont 1967) with those above. With the exception of the Upper Tees Clay, the tills of lowland Durham are remarkably similar, in terms of

Table 8.1. Particle Size Analysis. Sand, Silt and Clay Content.

		Percentages		
		SAND	SILT	CLAY
<u>South Tyne Valley.</u>				
Alston Town	713469	36.1	42.1	21.8
Clargillhead	736495	44.9	29.7	25.4
Glendue Burn	667566	39.9	48.4	11.7
Softley (erratic till)	677555	44.5	21.6	33.9
Softley (local till)	677555	34.9	38.3	26.8
Knar Burn	678532	31.2	42.0	26.8
Harbut Lodge	713473	40.6	18.9	40.5
Parsons Shield	684532	40.8	29.6	29.6
Thornhope Burn	679497	33.6	35.3	31.1
Byers Hall	652598	40.6	29.2	30.2
High Shield	648480	29.1	62.3	8.6
Gelt Burn	634503	28.5	61.6	9.9
Knar Burn	658510	33.8	40.6	25.6
Glendue Burn	647560	33.1	46.8	20.1
Glendue Burn	655565	23.8	57.6	18.6
Glendue Wood	676566	33.0	44.6	22.4
Glencune Burn	664620	41.8	26.6	31.6
Bellister Castle	695629	49.5	24.0	26.5
Thinhope Burn	646536	34.2	43.0	22.8
Hartley Burn	664602	42.6	25.2	32.1
<u>East and West Allen Dale.</u>				
Dingbell Hill	776586	40.9	17.9	41.2
Peasmeadows	852471	37.1	43.5	19.4
Mohope Burn	761490	30.9	57.5	11.6
Allendale Scar	838562	39.1	30.7	30.2
Parkgates	846542	25.9	45.3	28.8
Cupola	802586	35.8	41.7	22.5
Knockshield Burn	837506	45.6	25.8	28.6
Kiddygreen	809575	39.6	33.7	26.7
Carr's Burn	755543	34.2	35.3	30.5
Tarry Back	785578	34.4	31.5	34.1
Sipton Shield (erratic)	845500	37.3	26.8	35.9
Bearsbridge	779578	34.8	52.0	13.2
Pia Troon	826571	34.9	41.0	24.1

Cont. Table 8.1. Particle Size Analysis. Sand, Silt and Clay Content.

		Percentages.		
		SAND	SILT	CLAY
<u>Cont. East and West Allen Dale.</u>				
Turney Shield	799490	31.3	33.3	35.4
Bishop Field	828568	38.2	30.8	31.0
Bishopside	806583	37.0	45.3	17.7
Wellhope	780474	41.3	32.8	25.9
Bishop Field (local)	828568	35.6	34.1	30.3
Acton Burn	832514	28.6	41.6	29.8
Chapel House	819569	41.7	31.4	26.9
Sipton Shield	845499	32.8	43.6	23.6
Church Burn	785587	37.5	46.7	15.8
Whitfield Hall	779558	34.0	42.0	24.0
White Walls	778522	45.1	31.3	23.6
Sinderhope	843522	37.5	22.9	39.6
Wooley Park	834554	27.0	50.3	22.7
Sipton Shield Bridge	850499	24.4	41.5	34.1
Oakpool	865575	43.5	33.2	23.3
Sandyford Sike	805575	45.4	21.3	33.3
Hawksteel	809555	40.6	33.5	25.9
Allendale Cemetery	832556	37.8	24.9	37.3
Ninebanks	782539	36.9	29.6	33.5

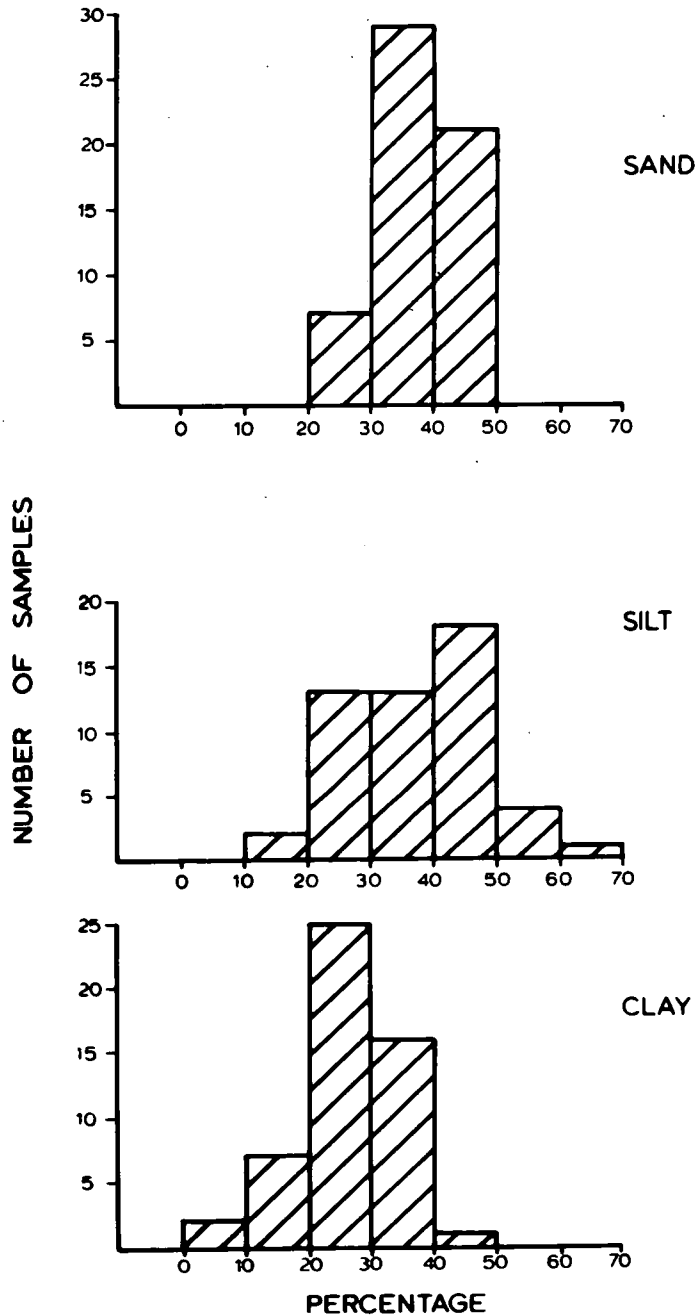
Table 8.2. Table for converting millimetres to phi units.

<u>millimetres.</u>	<u>phi units.</u>
20.0	-4.30
13.0	-3.70
9.7	-3.28
6.0	-2.59
4.7	-2.23
3.2	-1.68
2.0	-1.00
1.2	-0.27
0.6	0.73
0.4	1.32
0.3	1.74
0.2	2.32
0.15	2.74
0.10	3.32
0.075	3.73
0.062	4.01
0.030	5.06
0.018	5.79
0.008	6.97
0.004	7.95
0.002	8.94
0.001	9.97

(from Muller 1967, pp.269-274).

Fig. 8.1

**HISTOGRAMS OF THE SAND, SILT AND CLAY  
CONTENT OF TILL FROM NORTH-WEST ALSTON  
BLOCK.**



their absolute range of sand, silt and clay percentages, with those of the north-west Alston Block.

Beaumont (1967) has described a linear relationship between the sand and clay content of the tills of lowland Durham, having observed that the silt percentages are highly concentrated within a small range of values which may, therefore, be regarded as a nearly constant factor. No such relationship has been observed for the tills of the north-west Alston Block. Very probably this is due, in part, to the highly variable nature of the silt content of the tills in the Alston Block.

The reason for this difference in variability in silt content between the two adjacent areas is not clear, however, a tentative explanation is possible. It might be interpreted from the relationships between sand and clay content described by Beaumont (1967) that the ice-sheets which occupied lowland Durham were probably very effective in their ability to incorporate freshly eroded material. In the light of this statement the tills of the north-west Alston Block maybe regarded as relatively immature for want of a better term. Their innate variability might suggest an environment in which erosion and relatively rapid changes were dominant features.

It might also be argued that, in the case of the Alston Block, there is a lithological control producing this variability. Inspection of tills on very similar bedrock and having similar stone counts revealed that the silt content is still a very variable factor compared with sand and clay percentages.

Both the work of the present writer and that of Beaumont (1967) show that it is possible to demonstrate that tills slowly, but perceptibly, change their characteristics over an area. In other words, from the evidence presented in this thesis, and from the careful work of Beaumont (1967), it may be argued that till deposited by an ice-sheet is an evolving sediment and is not a random assemblage of crushed bedrock without any apparent order.

As Beaumont (1967) has indicated the textural parameters discussed above may be a diagnostic property determined by the process of deposition, and therefore unique to glacial tills, or they may be due to the character of the parent material. The present writer would add a third proposition to those of Beaumont's. The relative percentages of sand, silt and clay may

also be dependent of the relative stage of development of the till.

The triangular diagram, popularly used by the pedologist and geologist, has also been usefully employed in the field of glacial geomorphology. Dreimanis and Reavely (1953) were able to distinguish till sheets by plotting the relative percentages of sand, silt and clay on such a diagram. From the writer's field work it was known that both a local and a Lake District/Scottish till occurred within the north-west Alston Block. Fifty-two sand, silt and clay values were plotted on triangular co-ordinate paper to determine whether or not any meaningful groupings were present (Fig. 8.2a).

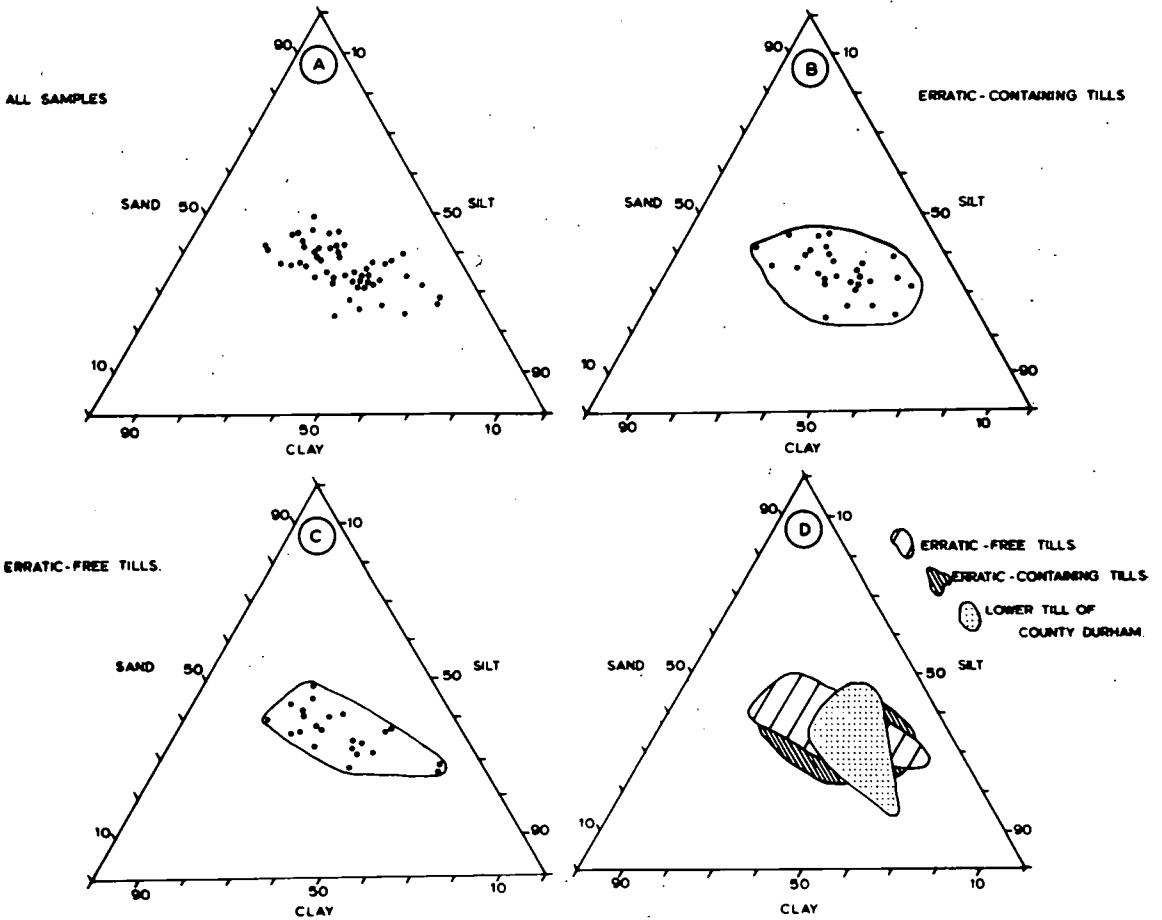
It may be observed (Fig. 8.2a) that no meaningful groups emerge. The clear cut demonstration of different till sheets by Shepps (1953) using such triangular co-ordinate paper distinguished between superimposed till sheets, which in general become successively finer grained upwards, due to the reworked nature of the deposits of the more recent till sheet. In the north-west Alston Block no such superimposed till sheets have been observed and for this reason it might not be possible to differentiate deposits using this method. It is known from stone counts that in terms of their gravel lithologies it is possible to distinguish local tills, without erratics, from those tills with erratics. The percentages of sand, silt and clay of the local tills and erratic-containing tills were plotted separately on triangular co-ordinate paper to highlight any relationship that might exist between lithology and percentage sand, silt and clay (Fig. 8.2b, c). It is seen that the distributions are very similar and it is concluded that in terms of the relative percentages of sand, silt and clay it is not possible to distinguish till types within the north-west Alston Block.

Before leaving the subject it might be useful, at this point, to compare the sand, silt and clay percentages of the Alston Block tills with those of the Lower Till of County Durham. Beaumont (1967) has recorded data on the sand, silt and clay percentages for the Lower Till of County Durham. The range of these values has been plotted on Figure 8.2d. In this figure it can be seen that about 50 per cent of the till samples from the Alston Block could be described, in terms of relative sand, silt and clay percentages, as being similar to the Lower Till of County Durham.



Fig. 8.2

PERCENTAGE OF SAND, SILT AND CLAY IN THE TILL SAMPLES.



In conclusion it has been indicated that some delicate adjustment of texture must have taken place as the ice of the last glaciation moved eastwards from the uplands of the Alston Block into lowland Durham. Such a textural evolution was probably more variable near the bedrock source of the tills but became more stable as the lowland environment was encountered.

#### Total Particle Size Analysis.

Total particle size analysis of each of the fifty-two samples of till from the north-west Alston Block was carried out using a nest of sieves (British Standards Institution type) and a pipette. Measurements of grain sizes were made within the range 20 mm. - 0.001 mm. and the results were plotted as cumulative frequency curves on semi-logarithmic graph paper in the manner recommended by the British Standards Institution (B.S.1377, 1961).

A total of twenty two grain size measurements were made for each sample corresponding to the following grain size diameters. (In millimetres):- 20.0, 13.0, 9.7, 6.0, 4.7, 3.2, 2.0, 1.2, 0.6, 0.4, 0.3, 0.2, 0.15, 0.1, 0.075, 0.062, 0.03, 0.018, 0.008, 0.004, 0.002, 0.001.

Visual comparison of cumulative grain size curves is difficult and statistical analysis is necessary for ease of comparison. To comply with accepted practice and for ease of calculation of the statistical parameters a system of phi units was used instead of the millimetre grade scale.

The phi units are found by conversion from the millimetre scale, where phi is  $-\log_2$  of the particle size diameter in millimetres.

Krumbein and Pettijohn (1938) pointed out that the most useful grade scales are those based on true geometric scales because of the advantages they offer in statistical analysis of the data and of the ease of conversion of the data. The range of each grade class can be made smaller quite simply without losing the geometric nature of the scale; that is, the number of experimentally determined points can be increased. Also, a geometric scale gives equal significance to ratios of size irrespective of the size ranges in which they occur.

Conversion from millimetres to phi units means that one division on the Wentworth grade scale, a commonly used scale, is the equivalent of one

unit on the phi scale. For every unit on the phi scale the value on the Wentworth scale is either doubled or halved. Negative values of phi units are the values coarser than 1 mm. and as the phi units increase the size of the particle decrease. The great advantage of this method is that small fractions are not required for the smaller particles and that for many of the common sediment sizes the results in phi units are positive (Table 8.2).

As pointed out by Inman (1952) the logarithmic scale also has an advantage in that the size frequency curve of most sediments becomes more symmetrical when the diameter of the grains is plotted as a logarithm of the real value.

The tails of a frequency curve may be of considerable importance in analysing the characteristics of a sediment and it is important that these values should be accurately obtained. This can often be done more easily if the frequency curve is plotted on arithmetic probability paper. This type of paper has the advantage that the normal distribution curve is a straight line on it, so that this provides a useful means of assessing the normality of the distribution at a glance (King 1960).

Beaumont (1967), however, pointed out that it is never possible to sample adequately the complete particle size range of a glacial till and it is also very difficult to measure, with any degree of accuracy, the finer particle size range of the deposit. A partial solution of the first problem is offered by arbitrarily defining the grain size range to be studied. In this thesis the upper limit of grain sizes considered in particle size analysis was 20 millimetres. The second problem is more difficult to solve in that sedimentation methods become inaccurate when dealing with particles less than one millimetre in diameter, below which Brownian motion develops and hinders gravitational settling.

In the following analyses the particle size range measured was, therefore, limited to that between 20.0 and 0.001 millimetres. The results of particle size analysis are shown in Table 8.3. Cumulative frequency curves were plotted for fifty two samples of till (Fig. 8.3).

#### Statistical Analysis of Cumulative Frequency Curves.

Statistical analysis of the cumulative frequency curves has been

Table 8.3. Results of Particle Size Analyses.

(Results are recorded as cumulative percent finer).

Particle size in mm.	* 1	2	3	4	5	6	7	8	9	10
20.000	100.00	100.00	100.00	100.00	100.00	100.00	100.00	100.00	100.00	100.00
13.000	92.76	98.70	97.51	93.18	95.64	97.30	98.27	95.53	95.69	98.50
9.700	91.16	98.38	95.96	90.71	94.21	95.88	96.99	93.44	94.22	97.50
6.000	88.96	97.48	93.77	87.25	91.19	94.03	95.68	90.73	92.66	95.50
4.700	87.24	96.61	91.86	84.78	89.44	92.10	94.17	88.64	91.56	94.60
3.700	85.09	95.19	89.10	81.25	87.00	89.60	92.47	86.28	90.14	92.50
2.000	82.82	93.60	86.39	78.30	83.80	87.60	90.45	84.24	88.71	90.22
1.200	79.90	90.72	82.30	76.26	79.50	85.45	88.01	81.97	86.94	87.40
0.600	75.51	87.03	78.03	74.27	77.40	82.45	85.24	79.20	82.89	82.09
0.400	73.27	85.43	76.26	70.02	74.14	80.70	83.58	77.90	80.83	79.76
0.300	70.17	83.11	74.27	67.86	70.87	76.88	81.20	76.07	77.52	75.31
0.200	66.15	78.87	72.02	63.65	64.57	73.01	77.36	73.18	73.32	71.08
0.150	61.14	73.38	68.58	59.37	57.81	67.33	70.70	70.05	67.82	66.05
0.100	55.41	66.56	64.22	54.78	51.65	59.62	63.18	66.29	59.61	61.42
0.075	50.29	62.15	60.98	50.83	47.42	54.76	56.50	63.39	51.58	60.29
0.062	48.97	58.88	59.63	49.98	46.20	52.69	55.17	62.42	49.19	57.95
0.030	47.20	48.40	48.10	40.10	40.00	40.30	48.70	53.00	47.35	48.50
0.018	45.60	42.00	38.10	34.70	35.50	33.70	44.00	46.10	44.84	41.80
0.012	42.81	37.10	31.50	31.00	32.20	26.80	40.80	41.50	42.68	36.80
0.008	39.68	32.30	25.10	28.20	30.10	22.50	37.50	37.00	39.54	32.50
0.004	37.24	25.00	16.10	23.00	26.00	15.10	31.80	31.00	34.60	26.00
0.002	34.14	18.10	10.00	17.00	21.34	10.28	27.29	24.33	30.03	20.30
0.001	27.30	14.20	-	14.80	13.50	-	19.10	15.50	23.00	14.00

\* Sample numbers are the same as in Table 7.1 and Figure 7.1.

Contd. Table 8.3. Results of Particle Size Analyses.

Particle size in mm.	* 11	12	13	14	15	16	17	18	19	20
20.000	100.00	100.00	100.00	100.00	100.00	100.00	100.00	100.00	100.00	100.00
13.000	94.92	97.48	98.64	98.15	85.60	94.10	98.17	98.15	94.50	97.51
9.700	92.78	96.05	97.29	96.41	83.84	92.05	96.13	97.89	93.48	96.10
6.000	89.26	93.60	94.58	93.84	81.84	89.06	93.94	96.95	91.80	93.55
4.700	87.32	91.73	93.22	92.22	80.45	87.63	92.12	96.09	90.55	92.24
3.700	84.91	89.30	91.43	89.51	78.64	85.49	89.72	95.14	88.78	90.31
2.000	82.50	86.90	89.86	86.74	76.93	82.67	87.40	94.35	87.34	88.51
1.200	80.01	83.57	87.96	83.25	74.24	80.96	84.60	91.41	85.51	85.67
0.600	76.38	74.30	85.24	79.01	70.69	77.83	81.20	87.33	83.16	81.72
0.400	74.02	76.95	83.68	77.27	69.16	76.07	79.40	85.18	82.00	79.52
0.300	70.65	73.82	81.14	74.83	66.85	73.59	77.01	82.17	80.16	76.45
0.200	65.38	69.73	77.28	71.37	63.55	69.88	73.47	78.16	76.70	72.45
0.150	58.50	64.61	72.20	67.01	59.95	64.54	68.18	72.99	71.52	67.11
0.100	51.43	58.75	66.80	62.64	55.65	58.35	62.57	67.24	66.21	61.02
0.075	45.45	53.51	62.97	58.64	51.95	53.18	57.80	62.44	62.23	55.54
0.062	44.39	52.49	61.82	57.10	50.52	52.50	57.00	61.44	60.04	54.68
0.030	39.00	46.50	53.00	48.10	46.20	48.43	47.00	51.00	50.60	44.50
0.018	36.50	42.20	46.70	44.90	42.80	47.12	40.80	44.90	44.50	39.80
0.012	34.80	39.00	42.20	41.20	40.70	44.60	34.00	40.10	40.10	36.10
0.008	32.50	36.10	38.00	37.90	37.60	40.56	29.20	36.20	35.60	34.20
0.004	28.90	30.20	31.90	32.50	32.60	37.77	19.90	28.90	38.00	28.10
0.002	23.82	23.18	24.08	26.40	26.26	30.02	11.50	22.79	22.18	27.36
0.001	17.00	16.00	18.90	17.90	17.00	19.78	-	16.90	17.20	22.30

\* Sample numbers are the same as in Table 7.1 and Figure 7.1.

Contd. Table 8.3. Results of Particle Size Analyses.

Particle size in mm.	* 21	22	23	24	25	26	27	28	29	30	31	32
20.000	100.00	100.00	100.00	100.00	100.00	100.00	100.00	100.00	100.00	100.00	100.00	100.00
13.000	96.85	88.50	96.30	98.64	98.62	97.99	96.64	98.85	98.13	97.56	94.85	98.45
9.700	95.88	86.37	94.48	97.27	97.71	96.63	94.83	98.25	96.31	96.62	93.99	97.00
6.000	93.25	83.74	91.26	94.92	96.27	94.02	92.79	96.24	92.95	94.03	90.72	94.96
4.700	91.94	81.77	89.04	93.28	95.18	92.31	90.92	94.59	90.84	92.44	88.64	93.96
3.700	89.55	79.50	86.52	90.95	93.87	90.36	89.05	92.49	87.70	90.12	85.97	92.01
2.000	87.44	77.48	84.31	88.66	92.60	88.43	86.60	90.18	84.95	87.92	83.44	90.55
1.200	84.12	75.22	82.20	85.30	90.86	86.34	82.90	86.40	81.68	84.86	80.25	88.88
0.600	79.83	72.87	78.30	81.70	88.54	83.31	81.21	81.70	77.79	80.77	76.36	85.61
0.400	77.48	71.55	76.75	80.09	87.13	81.33	78.50	79.50	76.20	78.72	74.78	82.95
0.300	74.40	68.75	74.04	77.89	85.15	78.17	74.20	76.50	73.90	76.00	72.66	78.96
0.200	70.57	63.32	68.57	74.50	82.34	73.46	69.80	72.60	69.98	72.50	69.59	74.24
0.150	65.96	57.11	61.61	69.40	77.52	66.75	64.40	68.10	64.76	68.19	66.54	68.54
0.100	60.69	51.80	55.10	63.60	72.60	59.51	60.40	54.03	58.48	63.37	62.59	61.13
0.075	55.82	46.70	50.50	58.30	67.20	53.47	59.30	57.70	52.27	59.04	57.55	54.32
0.062	55.05	46.02	49.47	57.04	66.13	51.53	58.20	56.37	50.24	58.07	55.40	53.74
0.030	40.00	41.00	38.90	47.10	51.00	42.00	50.60	44.00	43.20	44.40	45.20	46.60
0.018	38.50	38.00	33.50	42.90	49.50	36.70	44.00	35.10	38.70	39.60	41.80	42.50
0.012	34.00	37.00	30.50	36.00	46.10	33.10	40.00	33.20	35.80	36.10	38.10	38.20
0.008	29.50	35.00	28.00	33.20	40.00	30.80	39.00	25.10	32.40	32.00	34.90	36.00
0.004	22.10	33.50	24.60	29.10	34.10	27.10	27.00	19.00	29.00	26.70	29.50	31.00
0.002	15.49	31.36	21.81	24.00	27.61	23.70	20.40	14.26	25.16	21.12	25.93	27.27
0.001	--	26.10	16.00	19.10	21.00	20.00	15.80	--	21.00	17.90	18.00	22.00

\* Sample numbers are the same as in Table 7.1 and Figure 7.1.

Contd. Table 8.3. Results of Particle Size Analyses.

Particle size in mm.	* 33	34	35	36	37	38	39	40	41	42
20.000	100.00	100.00	100.00	100.00	100.00	100.00	100.00	100.00	100.00	100.00
13.000	96.37	99.43	98.73	98.73	93.91	97.42	93.56	98.57	97.50	96.23
9.700	95.30	98.11	97.70	97.70	92.59	94.71	92.39	96.87	95.84	93.56
6.000	93.28	95.02	96.83	96.83	89.92	91.62	89.23	94.06	93.77	90.48
4.700	91.85	92.92	95.97	95.97	88.28	89.65	87.50	91.56	92.53	88.38
3.700	89.93	90.02	94.94	94.94	86.13	87.08	85.06	89.00	90.74	85.75
2.000	87.95	87.30	93.88	93.88	83.94	84.60	82.69	86.50	88.91	83.31
1.200	85.10	83.67	92.24	92.24	81.33	80.50	79.06	84.01	86.88	80.56
0.600	80.30	79.78	90.37	90.37	77.87	74.26	76.55	80.13	84.04	77.53
0.400	77.89	78.01	89.40	89.40	75.86	71.42	74.99	78.18	82.26	76.16
0.300	74.10	75.58	87.85	87.85	72.76	68.76	73.20	75.28	79.84	74.04
0.200	68.11	71.97	84.80	84.80	68.13	65.30	70.78	70.75	75.93	69.90
0.150	61.91	66.89	80.87	80.87	61.83	59.30	66.85	64.40	69.94	64.30
0.100	54.60	60.94	70.51	76.51	54.66	52.86	61.02	57.50	62.93	59.04
0.075	49.66	52.29	65.14	72.14	48.44	47.50	54.47	52.40	56.70	53.77
0.062	48.27	54.47	62.98	70.98	47.44	46.16	53.70	51.40	55.31	52.53
0.030	39.00	45.30	53.10	57.10	39.00	39.50	42.60	39.90	47.90	41.10
0.018	35.00	42.10	47.20	52.30	34.10	37.00	38.00	35.00	44.00	36.70
0.012	31.00	40.90	39.20	48.00	31.90	34.00	33.10	31.80	41.80	33.90
0.008	29.70	39.90	34.70	44.60	27.50	33.00	31.50	28.90	39.10	31.20
0.004	24.50	34.00	26.10	39.20	23.00	29.90	27.60	25.80	34.60	28.50
0.002	20.74	22.80	19.90	32.10	19.50	28.17	22.14	22.41	33.14	27.82
0.001	15.30	17.01	15.00	24.90	16.10	24.00	16.00	18.10	28.00	21.60

\* Sample numbers are the same as in Table 7.1 and Figure 7.1.

Contd. Table 8.3. Results of Particle Size Analyses.

Particle size in mm.	* 43	44	45	46	47	48	49	50	51	52
20.000	100.00	100.00	100.00	100.00	100.00	100.00	100.00	100.00	100.00	100.00
13.000	95.57	98.70	98.70	98.40	98.97	98.57	98.23	95.20	90.80	95.77
9.700	94.67	98.29	98.29	95.81	97.04	97.66	96.09	93.00	87.10	93.55
6.000	92.95	96.32	96.32	93.20	95.69	95.03	93.84	89.00	83.50	90.61
4.700	91.06	94.29	94.29	91.25	93.81	93.32	92.16	86.50	81.47	88.67
3.700	88.86	91.67	91.67	88.39	91.79	90.90	90.70	84.00	79.28	85.84
2.000	86.66	89.11	89.11	85.97	88.68	89.02	88.93	81.80	76.18	83.55
1.200	84.47	85.11	85.11	82.13	84.48	86.07	84.30	79.50	72.48	80.18
0.600	81.16	80.46	80.46	78.18	82.38	83.00	80.60	75.09	70.68	75.82
0.400	79.46	78.03	78.03	76.33	80.58	81.44	77.90	71.60	68.81	72.70
0.300	77.90	76.02	76.02	74.73	78.10	79.27	75.10	66.70	65.70	69.69
0.200	75.37	73.61	73.61	72.30	75.50	76.09	70.40	61.70	62.10	65.32
0.150	71.71	70.99	70.99	68.55	72.95	71.47	65.50	55.60	58.50	59.80
0.100	66.64	67.59	67.59	63.27	71.08	65.60	59.10	47.30	53.80	53.03
0.075	62.95	64.93	64.93	59.31	69.90	60.39	53.50	42.60	52.70	49.18
0.062	61.28	63.70	63.70	56.87	66.00	59.70	51.70	41.40	50.06	47.87
0.030	40.00	40.10	40.10	43.20	53.00	46.90	44.10	33.90	33.90	40.00
0.018	37.90	31.30	31.30	35.50	47.10	40.20	40.10	30.00	28.10	36.00
0.012	31.80	28.01	28.01	32.10	40.90	35.10	36.30	29.01	26.90	32.80
0.008	22.10	26.20	27.00	28.00	35.80	31.00	34.70	26.30	23.00	30.09
0.004	14.10	18.10	17.90	24.20	26.10	24.70	31.00	23.00	19.90	28.00
0.002	7.33	8.80	8.90	21.94	17.09	20.00	28.10	21.70	17.32	26.01
0.001	-	-	-	18.00	13.00	14.90	23.00	16.40	10.90	22.00

\* Sample numbers are the same as in Table 7.1 and Figure 7.1.



employed for two reasons. Firstly, it enables simple comparisons, using the derived numerical data, between all the samples under analysis. Visual comparisons of more than a few curves are difficult if not impossible. Secondly, the results can be easily used for comparative purposes with those obtained by other workers using different methods of analysis.

Statistical Measures used for analysis.

1. Central Tendency.

a. Median.

The median is the 50 per cent value on the cumulative frequency curve and defines the size separating the sample into two equal halves by weight. The median has the disadvantage in that it takes no account of the distribution of the grain size on either side of the 50 per cent value.

b. Mean.

The sample mean, which represents the average of a series of readings has the advantage over the median in that it is more suitable for further mathematical analysis. Several recognised formulae are available for the calculation of the mean. Three more commonly used formulae are listed below, together with an indication of their efficiency which has been calculated by McCammon (1962).

Efficiency in Per cent.

i. Inman (1952)		
	$M\phi = \frac{1}{2}(\phi_{16} + \phi_{84})$	74
ii. Folk and Ward (1957)		
	$Mx = \frac{(\phi_{16} + \phi_{50} + \phi_{84})}{3}$	88
iii. McCammon (1962)		
	$M\phi = \frac{(\phi_5 + \phi_{15} + \phi_{25} + \phi_{35} + \phi_{45} + \phi_{55} + \phi_{65} + \phi_{75} + \phi_{85} + \phi_{95})}{10}$	97

Folk and Ward (1957) have shown that Inman's formula for the mean provides a good result for fairly normally distributed curves, but if these are very asymmetrical, or bimodal in character then the results are not so satisfactory. McCammon's formula, while being the most efficient of

Fig. 8.3

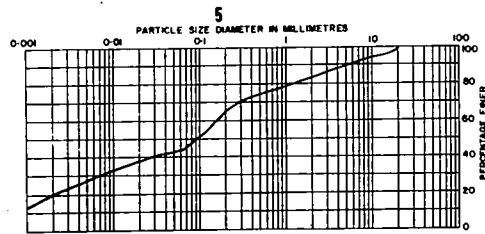
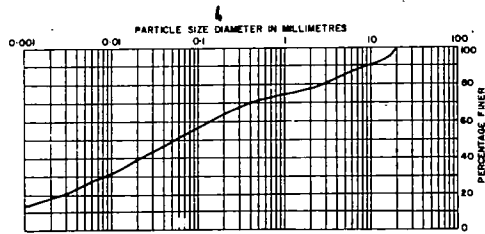
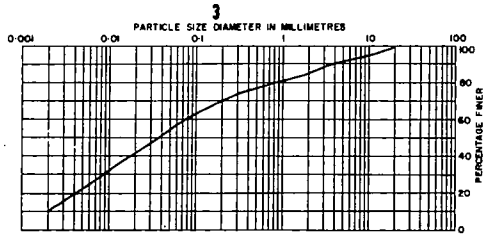
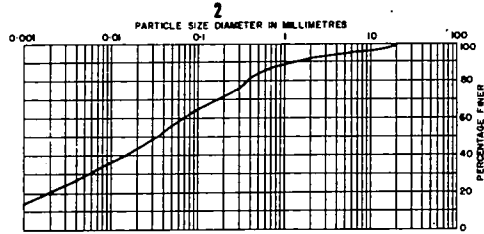
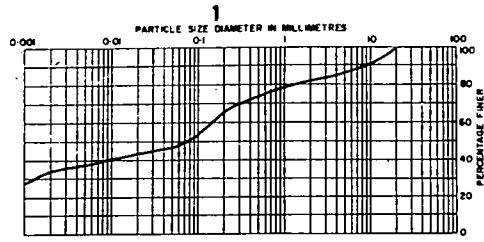


Fig. 8.3

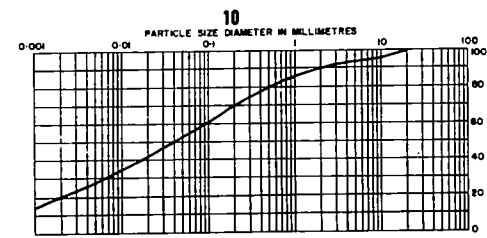
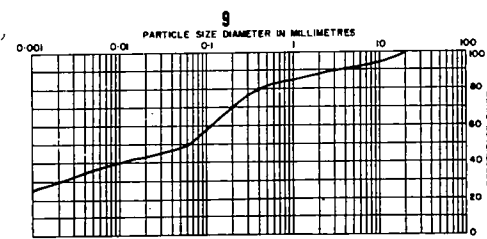
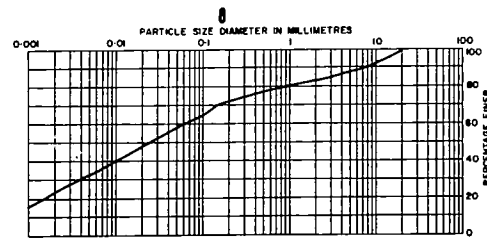
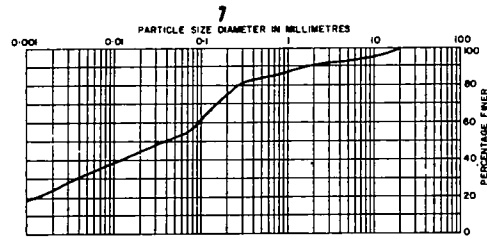
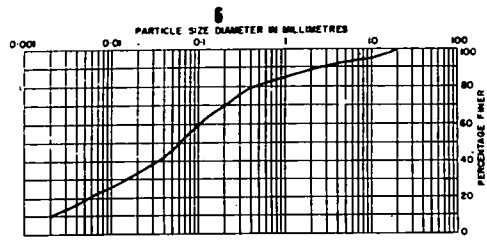


Fig. 8.3

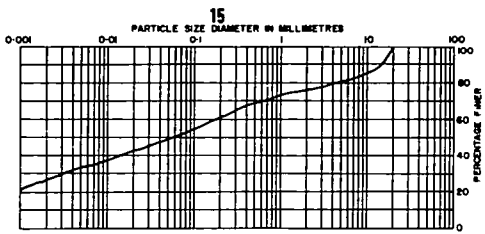
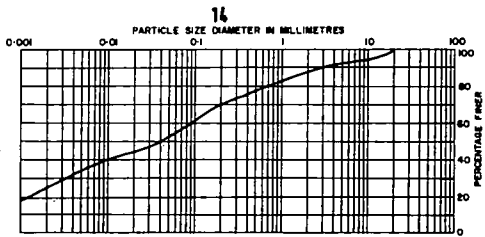
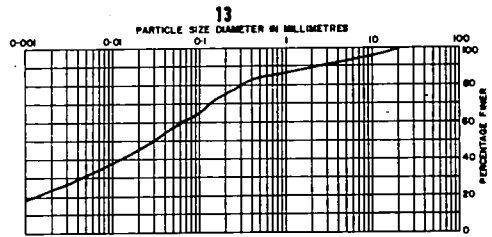
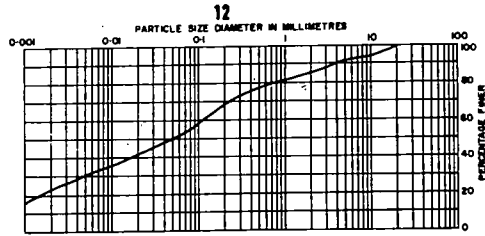
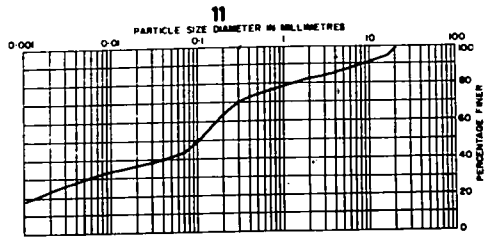


Fig. 8.3

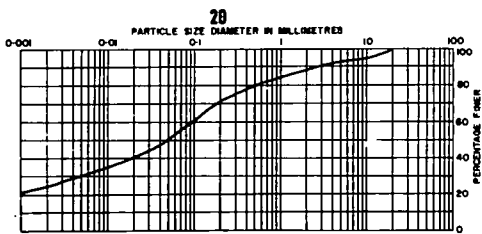
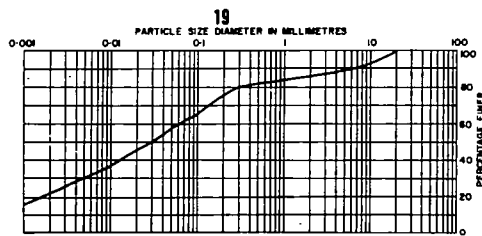
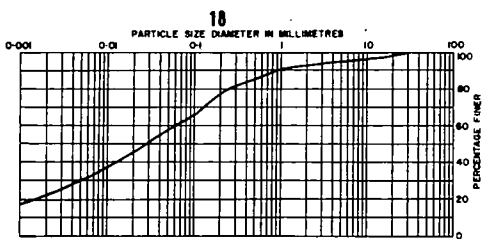
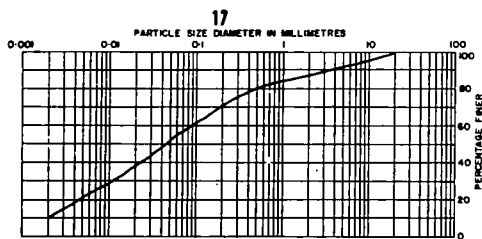
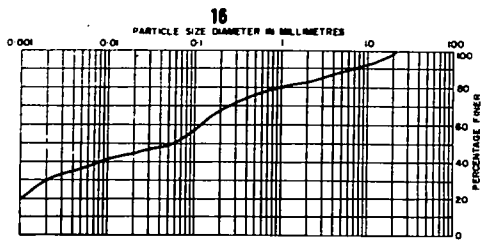


Fig. 8.3

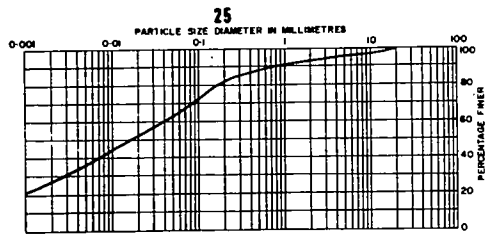
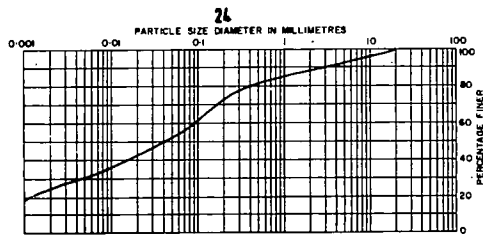
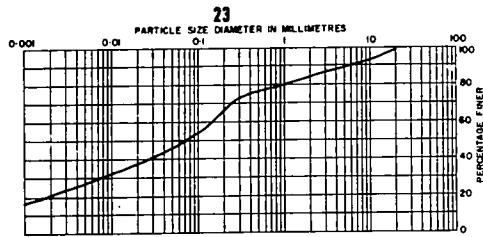
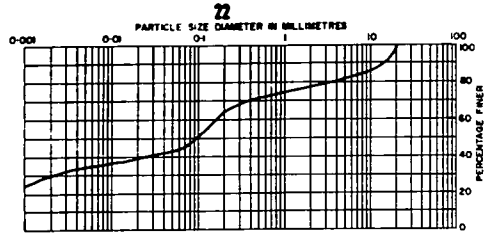
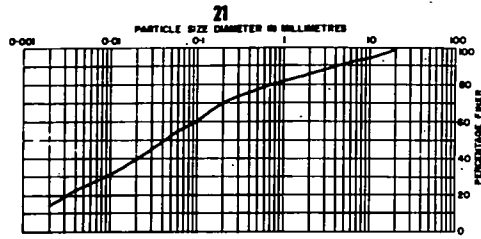


Fig. 8.3

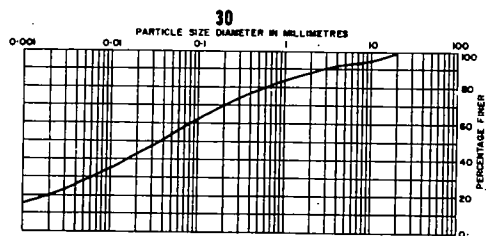
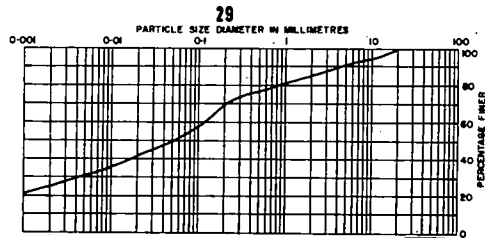
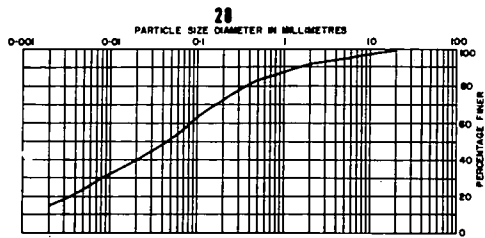
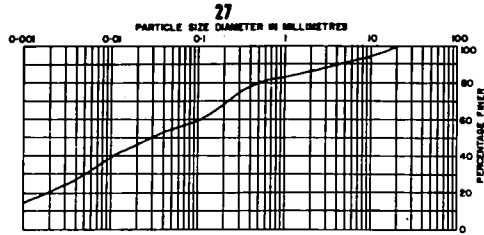
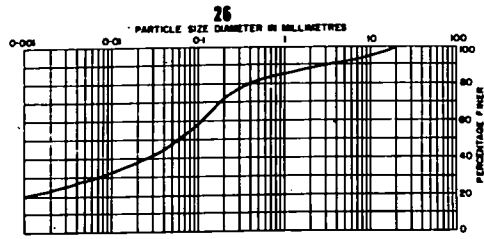


Fig. 8.3

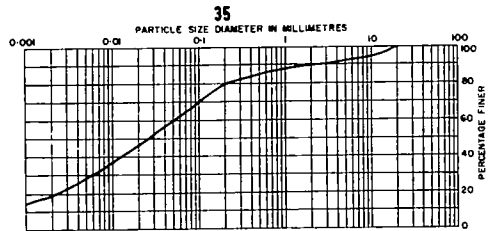
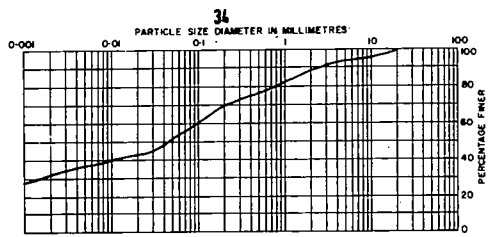
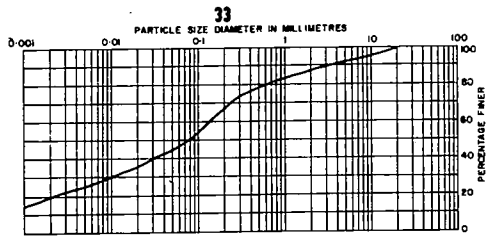
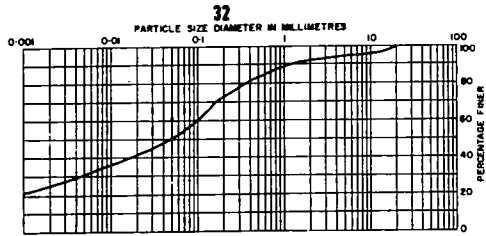
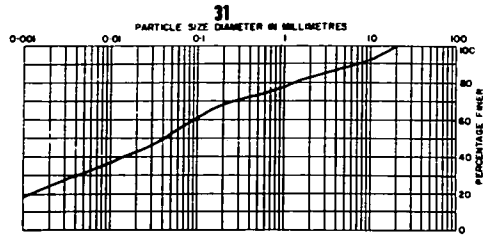




Fig. 8.3

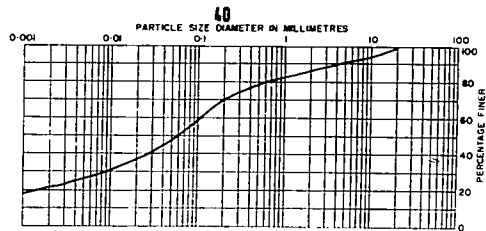
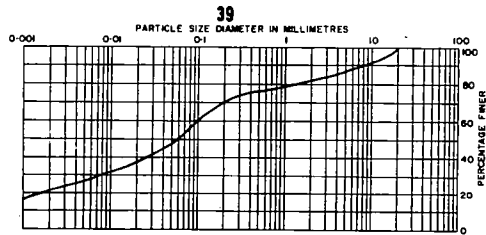
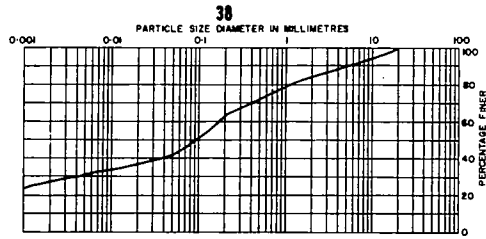
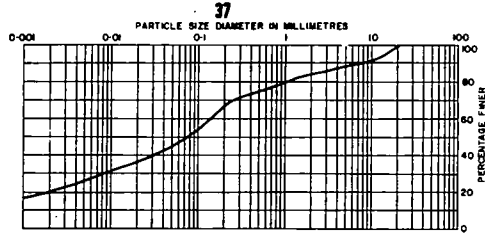
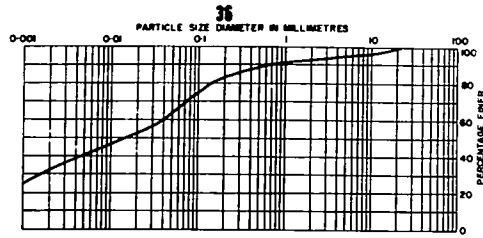


Fig. 8.3

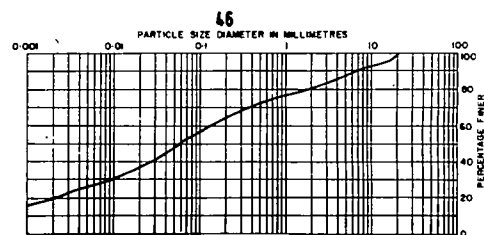
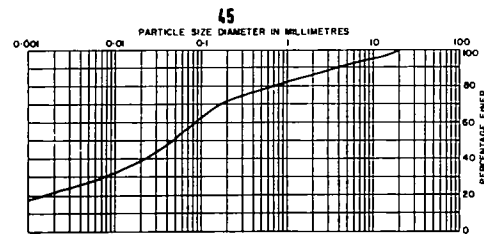
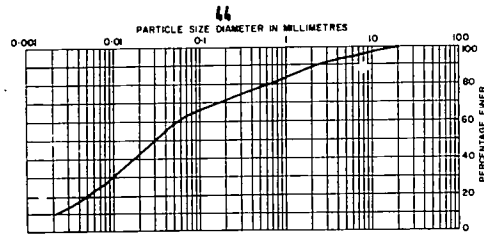
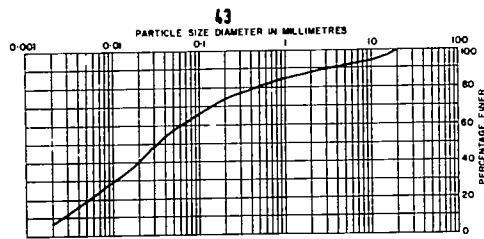
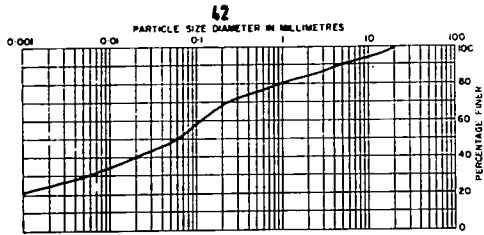
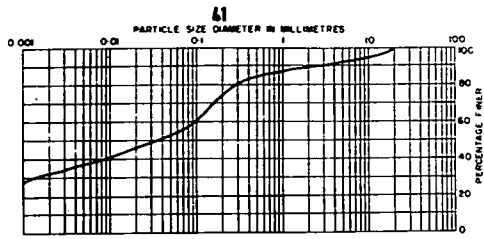
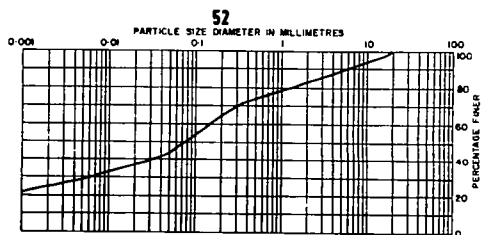
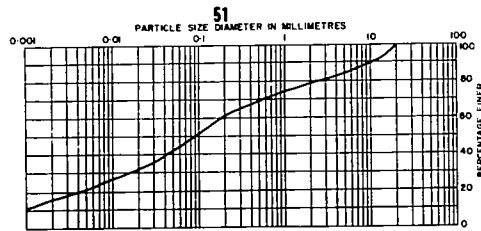
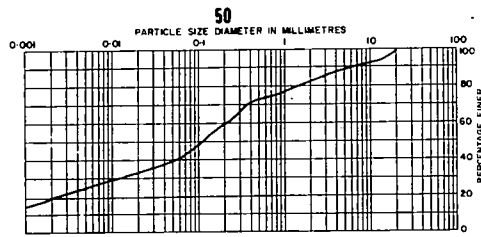
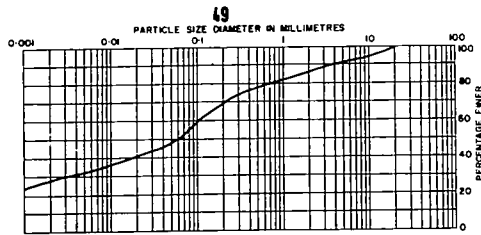
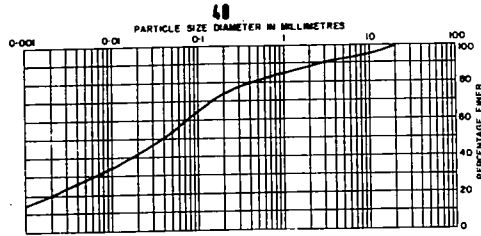
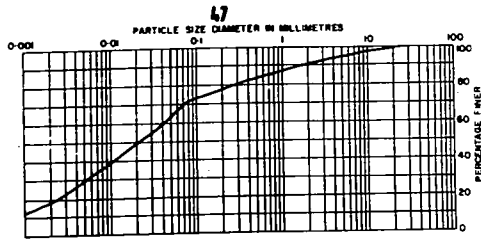


Fig. 8.3



those cited was not applicable in that for most samples no accurate five and fifteen percentile value could be obtained. Folk and Ward's formula was therefore used to calculate the mean particle size.

## 2. Sorting.

The degree of sorting is essentially a measure of the spread of the size frequency distribution. By using phi values for the 16th and 84th percentiles a direct measure of the standard deviation, a useful measure of dispersion, can be obtained. Inman (1952) suggested a parameter called the phi deviation measure:

$$\text{phi deviation} = \frac{1}{2}(\phi_{84} - \phi_{16})$$

Inman's formula has been found to give good results for nearly normal distributions but is not adequate to describe all sediments as it ignores at least one third of the sample at either end of the range of sizes. It may give misleadingly high sorting values if there is only a small amount of coarse or fine material present. A more efficient method is advocated by Folk and Ward (1957) who suggest a sorting measure which they call the Inclusive Graphic Standard Deviation.

$$\sigma_1 = \frac{\phi_{84} - \phi_{16}}{4} + \frac{\phi_{95} - \phi_5}{6.6}$$

The above formula could not be applied to the particle size curves of the glacial till as measured by the writer because of the difficulty in obtaining accurate phi 5 percentile readings. Inman's formula (Inman 1952) has therefore been used.

## 3. Skewness.

The deviation of the frequency curve from the symmetry of a normal distribution is described as skewness. In a symmetrical distribution the mean and the median coincide and there is no skewness. The amount and direction of skewness can be obtained, according to Inman's formula (1952), by comparing the mean and the median values.

$$\text{Sk} = \frac{\text{Mean } \phi - \text{Median } \phi}{\phi \text{ Standard Deviation}}$$

For coarse sediments Inman (1952) has shown that if the skewness is negative the mean is less than the median and the distribution is skewed

towards the smaller  $\phi$  values, or coarser particles. If the skewness is positive the distribution is skewed towards the high  $\phi$  values, or the finer particles.

Folk and Ward (1957) discussed the methods of assessing skewness and proposed a formula for an Inclusive Graphic Skewness.

$$Ski = \frac{\phi_{16} + \phi_{84} - 2\phi_{50}}{2(\phi_{84} - \phi_{16})} + \frac{\phi_{5} + \phi_{95} - 2\phi_{50}}{2(\phi_{95} - \phi_{5})}$$

They claim that their Inclusive Graphic Skewness is a better measure of the overall skewness and is also independent of sorting; Inman's formula is not. As before, the difficulty of obtaining accurate phi 5 percentile values militated against the writer's use of the Inclusive Graphic Skewness and recourse was made to the formula recommended by Inman (1952).

#### Results of Statistical Analysis.

Fifty two samples from the South Tyne and Allendale valleys were statistically analysed by the methods outlined above. The results of the statistical analysis are shown in Table 8.4.

##### 1. Central Tendency.

###### a. Median.

The median values show an absolute variation from 3.1  $\phi$  to 5.9  $\phi$ . The median phi values for all fifty-two samples were plotted as a histogram (Fig. 8.4). It can be seen from Figure 8.4 that the distribution appears to be normal indicating a marked tendency for a concentration of values, for the tills of the north-west Alston Block, between 3.5  $\phi$  and 5.5  $\phi$ .

The fifty-two median phi values were also arbitrarily divided in terms of their micro-stone counts into local tills (those without any erratic material) and those containing erratic material. It was thought that because of their varying lithology it might be possible to distinguish local and foreign till in terms of their median particle size. The phi median values for the two types of till were plotted as simple histograms (Fig. 8.4). An inspection of Figure 8.4 indicates that both the local and erratic-containing till have a similar absolute range of phi median values, although those tills containing erratic material tended to be more concentrated within one or two categories.

Fig. 8.4

## PHI MEDIAN PARTICLE SIZE

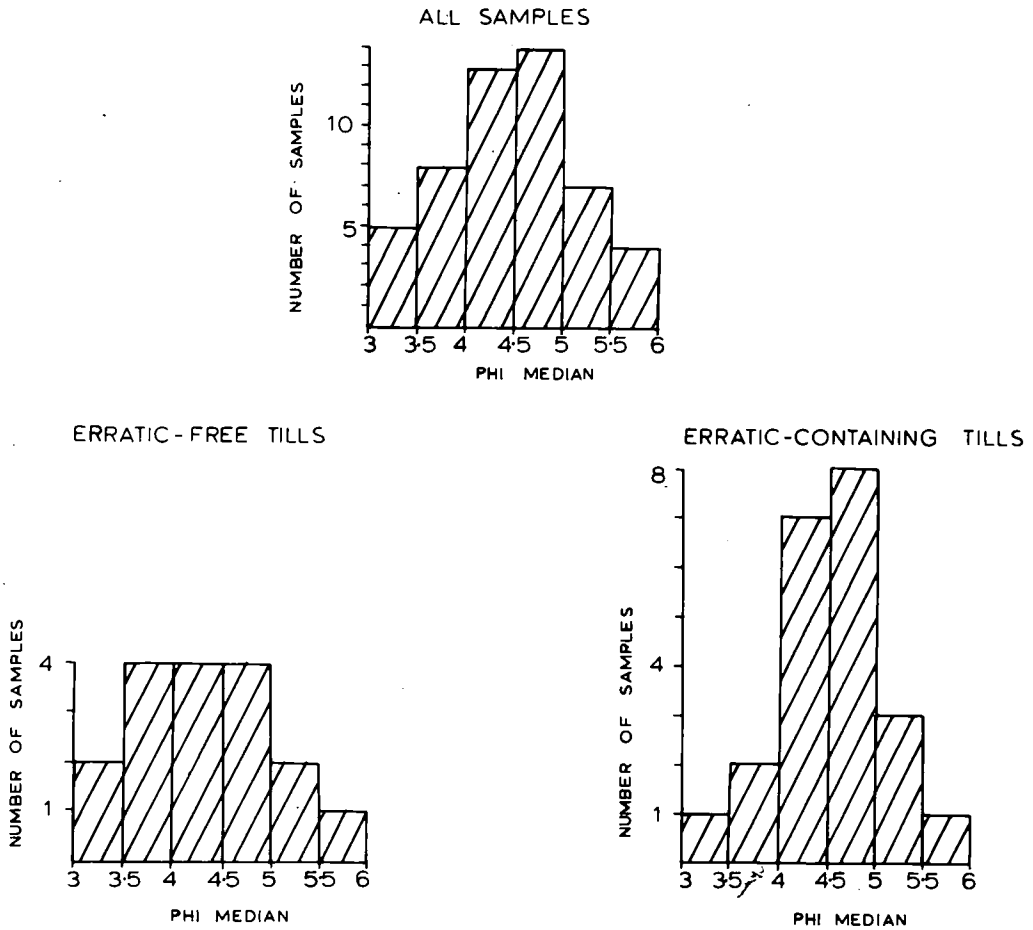


Table 8.4. Results of Statistical Analyses of Particle Size Curves.

<u>Sample No.</u> *	<u>Median %</u>	<u>Mean %</u>	<u>% Sorting</u>	<u>% Skewness</u>
1	3.7	4.4	6.5	0.1083
2	4.9	5.2	4.1	0.0731
3	5.0	4.0	4.3	-0.2209
4	3.7	3.6	5.6	-0.0176
5	3.4	3.8	5.4	0.0740
6	4.2	4.1	3.7	-0.0090
7	4.7	5.4	4.7	0.1472
8	5.4	4.7	5.4	-0.1235
9	3.9	5.0	5.4	0.2005
10	4.9	4.9	4.3	0.0072
11	3.3	3.8	5.7	0.0869
12	4.4	4.4	5.3	0.0124
13	5.4	5.5	4.6	0.0282
14	4.6	4.8	5.4	0.0492
15	4.0	3.6	6.6	-0.0551
16	4.3	4.2	5.7	-0.0069
17	4.3	4.2	4.5	-0.0222
18	5.2	5.5	4.2	0.0705
19	5.1	5.1	4.8	0.0138
20	4.4	5.2	5.6	0.0142
21	4.5	4.5	4.8	-0.0367
22	3.4	3.9	7.0	0.0757
23	3.7	4.1	5.4	0.0862
24	4.7	4.9	5.1	0.0509
25	5.7	5.8	4.6	0.0344
26	5.3	5.5	5.2	0.0384
27	5.2	4.8	5.1	-0.0654
28	4.6	4.3	4.1	-0.0404
29	4.0	4.4	5.6	0.0832
30	4.9	4.7	5.0	0.0461
31	4.6	4.3	6.0	-0.0438
32	4.4	5.4	4.9	0.2040
33	3.7	4.3	4.9	0.1359
34	4.5	5.3	6.2	0.1387
35	5.5	5.4	4.1	-0.0139
36	5.9	6.8	5.3	0.1698
37	3.6	4.2	5.5	0.1140
38	3.3	4.5	6.1	0.1967
39	4.1	4.2	5.7	0.0173
40	4.0	4.8	5.2	0.1538

\* Sample numbers are the same as in Table 7.1 and Figure 7.1.

Contd. Table 8.4. Results of Statistical Analyses of Particle Size Curves.

<u>Sample No. *</u>	<u>Median %</u>	<u>Mean %</u>	<u>% Sorting</u>	<u>% Skewness</u>
41	4.7	5.4	5.1	0.1475
42	4.0	4.5	6.1	0.0868
43	4.8	4.2	3.9	-0.1538
44	4.8	4.1	3.9	-0.1710
45	4.5	4.9	5.9	0.0677
46	4.2	4.0	5.8	-0.0290
47	5.5	5.1	4.2	-0.0952
48	4.7	4.9	4.6	0.0434
49	4.0	4.9	5.9	-0.1581
50	3.1	3.8	5.7	0.1332
51	3.6	3.4	6.2	-0.0216
52	3.6	4.5	6.3	0.1476

\* Samples numbers are the same as in Table 7.1 and Figure 7.1.



b. Mean.

Phi mean values were also plotted in histogram form (Fig. 8.5). The absolute range of values is from 3.5  $\phi$  to 6.8  $\phi$  with the mode lying between 4.0  $\phi$  and 4.5  $\phi$ . The local tills have a greater absolute range of phi mean values, varying from 3.5  $\phi$  to 6.8  $\phi$  with low modal classes, 4.0  $\phi$  - 4.5  $\phi$  and 4.5  $\phi$  - 5.0  $\phi$ . The foreign tills were more restricted in range varying from 3.5  $\phi$  to 5.86  $\phi$  with a single modal class from 4.0  $\phi$  to 4.5  $\phi$ .

2. Sorting.

Absolute values of sorting range from 3.9  $\phi$  to 7.0  $\phi$  (Fig. 8.6). The distribution of values indicates a normal distribution with a modal class from 5.0  $\phi$  to 5.5  $\phi$ . There does appear to be some overall tendency for the tills of the Alston Block to have sorting values concentrated between 4.0  $\phi$  and 6.5  $\phi$  (88 per cent of all the samples under analysis).

When analysed separately it is seen that both local and erratic-containing tills exhibit a similar range of sorting values (Fig. 8.6). Local tills vary from 3.6  $\phi$  to 6.8  $\phi$ ; those with erratics vary from 3.9  $\phi$  to 7.0  $\phi$ .

Folk and Ward (1957) have suggested a verbal scale to describe sorting:-

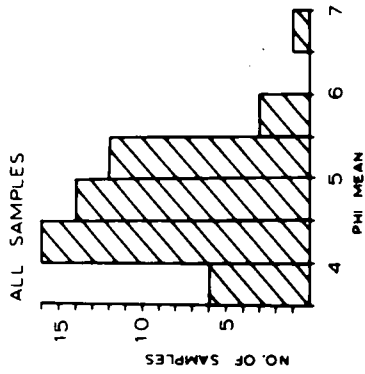
less than 0.35	very well sorted.
0.35 - 0.50	well sorted.
0.50 - 0.70	moderately well sorted.
0.70 - 1.00	moderately sorted.
1.00 - 2.00	poorly sorted.
2.00 - 4.00	very poorly sorted.
greater than 4.00	extremely poorly sorted.

All the till samples examined may be described as very poorly or extremely poorly sorted.

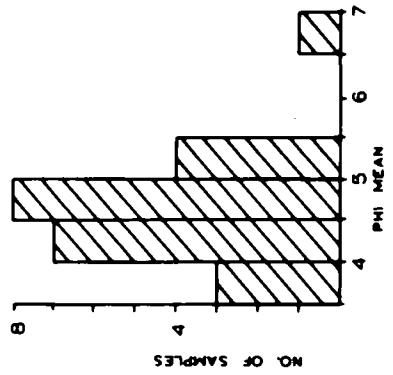
King (1966) pointed out that sorting does, to some extent, depend on the grain size of the material and a description of the degree of sorting may be misleading unless two materials of the same general size are compared. To assess if any relationship existed between the mean particle size and sorting of the tills of the north-west Alston Block fifty-two values for these two

Fig. 8.5

# PHI MEAN



## ERRATIC-FREE TILLS



## ERRATIC-CONTAINING TILLS

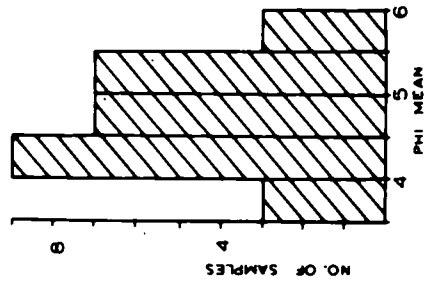


Fig. 8.6

# PHI SORTING

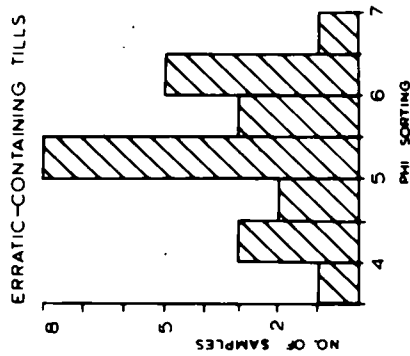
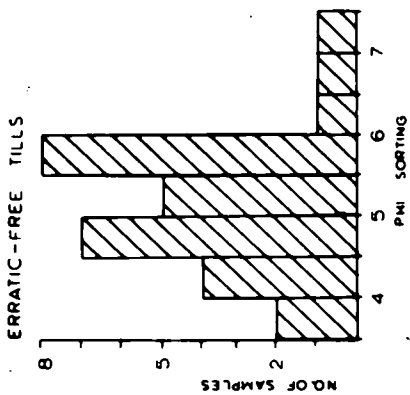
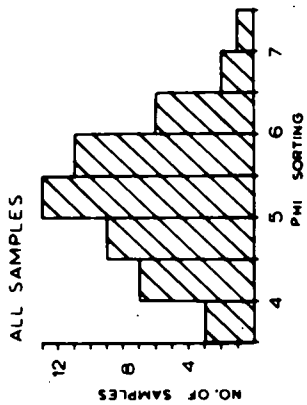
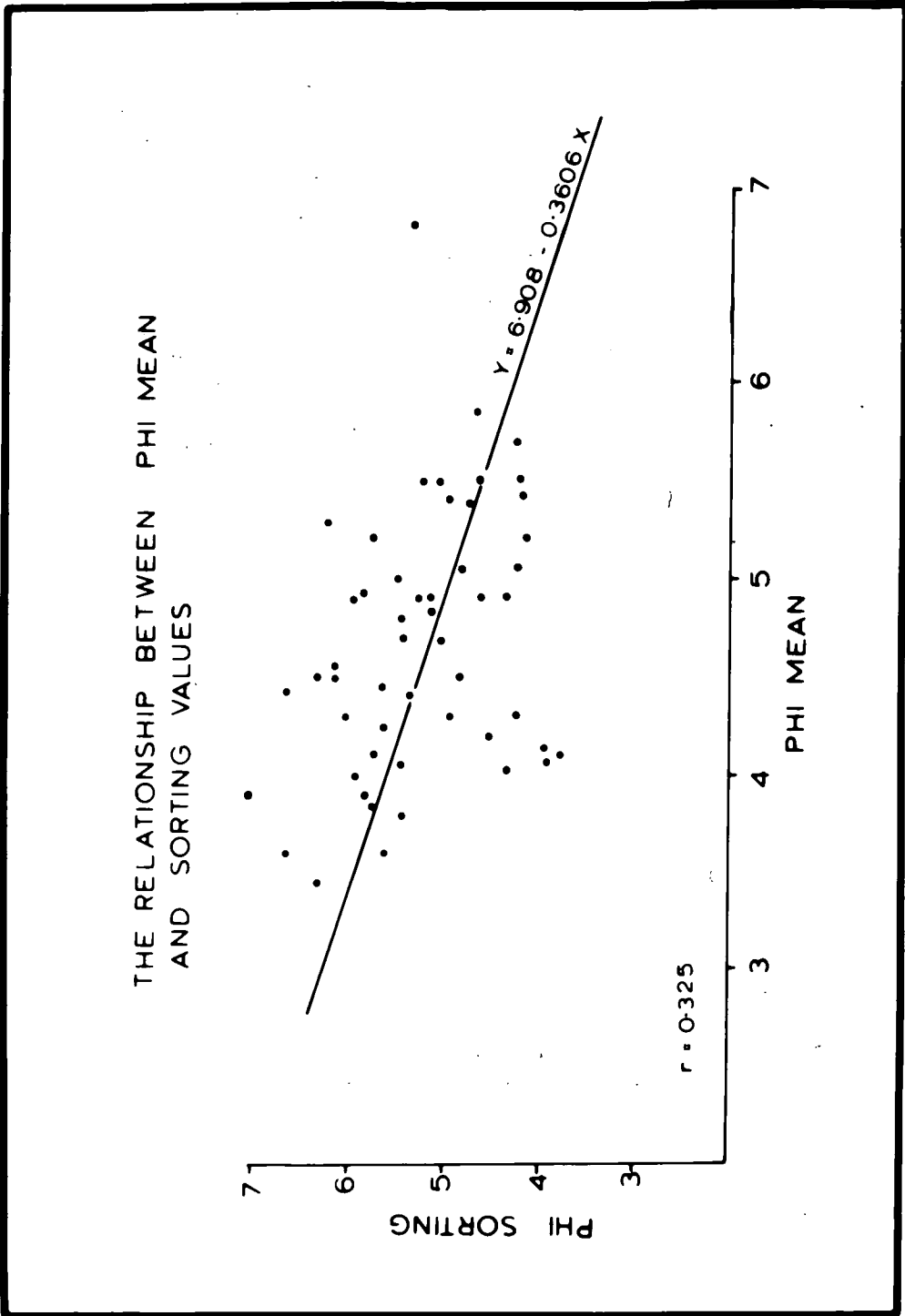


Fig. 8.7



variables were plotted graphically (Fig. 8.7). Statistical analysis gave the following results:-

correlation coefficient  $-0.325$  significant at the 95% level of probability.

regression equation  $y = 6.7174 - 0.3174X$

The results suggest that phi sorting deteriorates as the phi mean particle size of the deposit increases. Similar results have been described by Folk and Ward (1957) in a study of the offshore deposit of south Lincolnshire. Beaumont (1967) also found a significant relationship between these two variables for the Lower Till of County Durham.

### 3. Skewness.

The calculated phi skewness values for the fifty-two samples from the Alston Block are plotted as a histogram (Fig. 8.8). The absolute range of skewness varies from  $-0.2209 \phi$  to  $0.2040 \phi$ . Both the local and the erratic-containing till have the majority of their values showing positive skewness. 69.5 per cent of the local till and 58 per cent of the foreign samples were positively skewed.

Friedman (1961) used several of the moment measures described above in an attempt to differentiate depositional environments. By plotting phi mean particle size against phi skewness he was able to differentiate several types of environment. To see if any such relationships existed for the tills of the north-west Alston Block and to examine the possibility of differentiating types of till using this relationship, phi mean values were plotted against phi skewness (Fig. 8.9). Statistical analysis indicated a coefficient of correlation of  $0.300$  (Significant at the 95% level). The regression equation was:  $Y = 2.477 + 0.3939X$ .

From this graph it is seen that as the mean particle size decreases the skewness changes from negative to positive. No significant differentiation is seen in Fig. 8.8 and it was therefore necessary to test whether or not the two types of till between local and erratic-containing tills have significantly different phi mean, sorting and skewness values. To assess this the non-parametric Kolmogorov-Smirnov two sample tests were employed (Siegal 1956). The Kolmogorov-Smirnov test is a test of whether or not in terms of the variable under test, that the two samples have significantly different values. The test is sensitive to any kind of difference in the distributions from which the variables were drawn. When compared with the t test, a parametric

Fig. 8.8

# PHI SKEWNESS

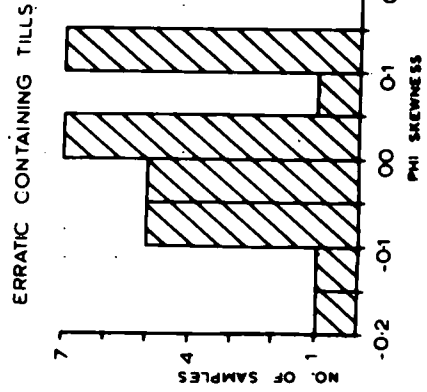
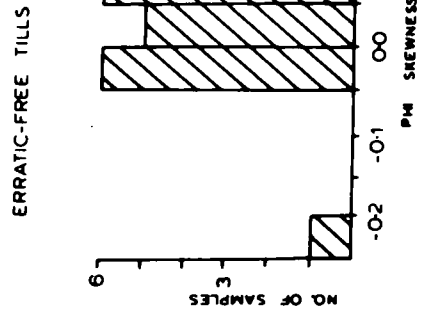
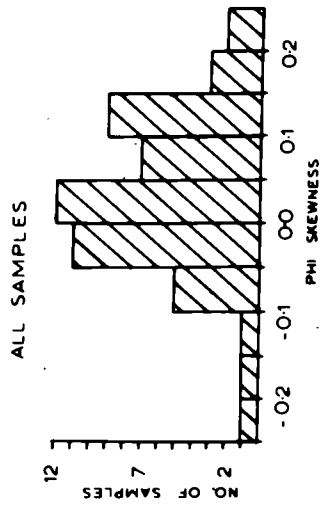
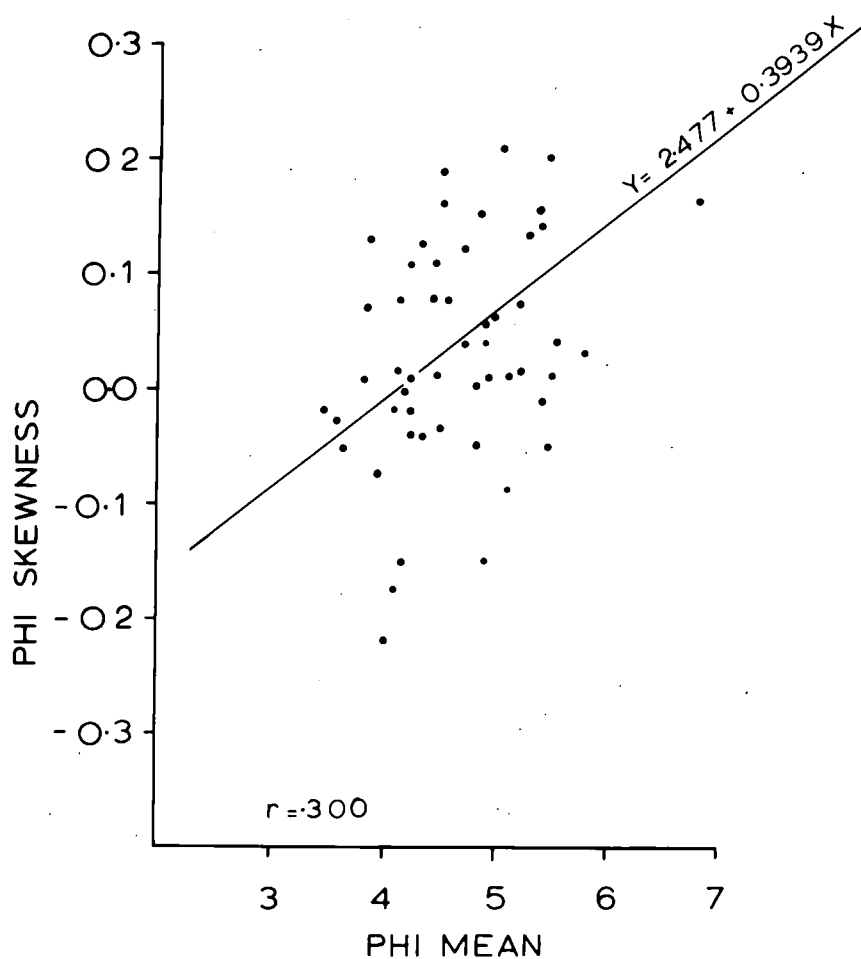


Fig. 8.9

THE RELATIONSHIP BETWEEN PHI  
MEAN AND PHI SKEWNESS



( To aid calculation a scale from +1 to +7  
was substituted for the phi skewness scale )

equivalent, the Kolmogorov-Smirnov test has a high power efficiency (about 96 per cent).

i. Comparison of the phi mean values.

Calculated D	0.06
Computed Chi square	0.184
Tabulated Chi square at the 95 per cent level of significance	5.99

As the calculated Chi square is less than the tabulated the null hypothesis that erratic-containing tills have significantly different phi mean values is rejected at the 95 per cent level of probability.

ii. Comparison of the phi sorting values.

Calculated D	0.188
Computed Chi square	1.812
Tabulated Chi square at the 95 per cent level of significance	5.99

As the calculated Chi square value is less than the tabulated the null hypothesis that erratic-containing tills have significantly different phi sorting values is rejected at the 95 per cent level of probability.

iii. Comparison of the phi skewness values.

Calculated D	0.13
Computed Chi square	0.866
Tabulated Chi square at the 95 per cent level of significance	5.99

As the calculated Chi square is less than the tabulated the null hypothesis that the erratic-containing tills have significantly different phi skewness values is rejected at the 95 per cent level of probability.

These results indicate that the two, arbitrarily classified, types of till do not differ significantly in terms of their phi mean, sorting and skewness values. As, however, the initial classification was somewhat subjective, it is, perhaps, worthwhile considering the raw data more carefully.

Many of the red tills derived from the Vale of Eden and the Carlisle Plain appeared in the field to be sandier in texture than the tills of a more



*easterly* provenance, which are on the whole rather tenacious sediments. Such a simple classification of the tills into those which contain erratics and those which do not is not wholly satisfactory. It has been indicated that during the last glaciation of the area the major ice movements took place from west to east. It has also been shown that the lithologies to the west of the study area are essentially different to those found in the study area. It might be expected therefore that an ice-sheet traversing from one lithological environment to another might also be expected to gradually change the characteristics of the deposits formed and carried at its base.

If this simple premise is accepted then perhaps, instead of discrete differences in particle size characteristics between the two types of till there is a continuum of variation. The particle size characteristics may be considered to vary between those characteristics attributable to the tills containing very high percentages of erratics and those tills which are essentially local in character.

In order to test whether or not such a notion can be proven the writer attempted a number of simple statistical analyses. The essence of the analyses was to see if the particle size parameters, gravel, sand, silt and clay were related statistically to particular lithologies as measured in the stone counts. For instance do those tills which contain high percentages of silt also contain high percentages of shale in the stone count? If statistically significant results from such correlations are obtained it might be possible to indicate further the nature of the evolution of the tills in the north-west Alston Block and also the influence of lithology on such areal changes in the particle size characteristics of the tills.

The results of the correlation analyses are shown in Table 8.5. A number of interesting observations may be made from the correlation in Table 8.5.

Table 8.5. A simple correlation matrix of lithological and particle size parameters of the tills of the north-west Alston Block.

	Percentage of each particle size group.			
	<u>Gravel.</u>	<u>Sand.</u>	<u>Silt.</u>	<u>Clay.</u>
Sandstone	0.024	-0.095	0.056	-0.073
Shale	-0.253	-0.255	<u>0.393</u>	<u>0.329</u>
Erratics	0.041	<u>0.358</u>	-0.288	-0.178
Limestone	<u>0.415</u>	-0.003	-0.270	-0.186

       significant at the 0.001 level.             significant at the 0.05 level.

i. It would appear from Table 8.5 that the only significant correlation between the percentage of gravel, in the particle size results, and the lithological variables is that with the limestone content of the till. The highly significant correlation of 0.415 indicates that the tills containing an abundance of limestone in the stone counts also contain most gravel size material within the samples analysed.

ii. A significant positive relationship occurs between the percentage of sand in the particle size results and the erratic content of the tills. This positive correlation indicates that as the erratic percentage of the tills increase then so too does the sandiness of the tills. This result would seem to confirm the writer's visual impression that the tills become less sandy in an easterly, down-ice direction. This result adds further evidence to the contention that the tills are to some extent ordered deposits. Probably the sand content of the erratic tills is very largely derived from the Permo/Triassic formations which because of their friable nature would be very easily broken down into individual grains.

iii. As expected it is seen that the siltiness of the tills is significantly correlated with the shale content in the stone count (Table 8.5) indicating that tills with higher percentages of shale in the stone counts are also more silty.

iv. Table 8.5 indicates that the clay content of the tills is positively correlated with the percentage of shale in the stone counts.

Apart from indications that the till deposits are clearly related to the lithologies over which the ice has passed it is also possible to suggest that various lithological groups, once have been incorporated into the till breakdown into particular size ranges. Obviously, this will depend on a number of factors such as the initial particle size of the bedrock and in the case of sandstones the nature of the cementing medium and the original size characteristics of the individual sand grains. For example, Table 8.5 indicates that shale when crushed by ice and incorporated into the body of the till, are broken down into the silt range and to a lesser extent into the clay size range. On the other hand, Table 8.5 indicates that the erratic lithologies when crushed by ice form predominantly sand sized material. Furthermore, the limestones would appear relatively resistant to abrasion and

seem relatively stable within the gravel size range.

Such simple correlations may be put to further use particularly in the design of experiments. If it was necessary for instance to study the mineralogy of the erratic minerals by such a detailed correlation study it would be possible to determine which would be the most profitable size range to study.

Useful though statistical analyses are, they should not be used to the total exclusion of visual analyses; often such statistical analyses fail to reveal simple graphical phenomena. One such feature is the break of slope which is seen in many of the writer's analyses (Fig. 8.3). After much painstaking laboratory work Beaumont (1967) was able to show that the break of slope is almost precisely associated with a change in the nature of the sediment from a dominance of rock fragments to one of mineral grains and is, therefore, a reflection of the parent material. Beaumont (1967) also suggested that in different areas of the country it would appear likely that this break of slope in the cumulative frequency curve would take place at different grain sizes and be a reflection of the nature of the parent material over which the ice was moving.

#### Analyses of Lacustrine Sediments.

To confirm the writer's visual impressions gained in the field the lacustrine silts found in East Allen Dale were subjected to particle size analysis. The aim of such analysis was to determine the rhythmic nature of the sediment.

Several attempts were made to obtain large samples of the laminated silt deposits but this proved very difficult. When wet, and easy to cut, the deposit had the consistency of thick porridge and was extremely dangerous to walk upon. When dry it was hard and brittle and large samples could only be obtained by forceful digging. Such dry samples proved useless as it was impossible to cut them without their splitting along the laminae. Several dry samples were re-wetted but they, too, split as the water penetrated along the bedding planes forcing the laminae apart. In the end the writer had to content himself with a number of small, but fairly representative, samples.

It is possible that Derryhouse (1902) has also seen such sediments

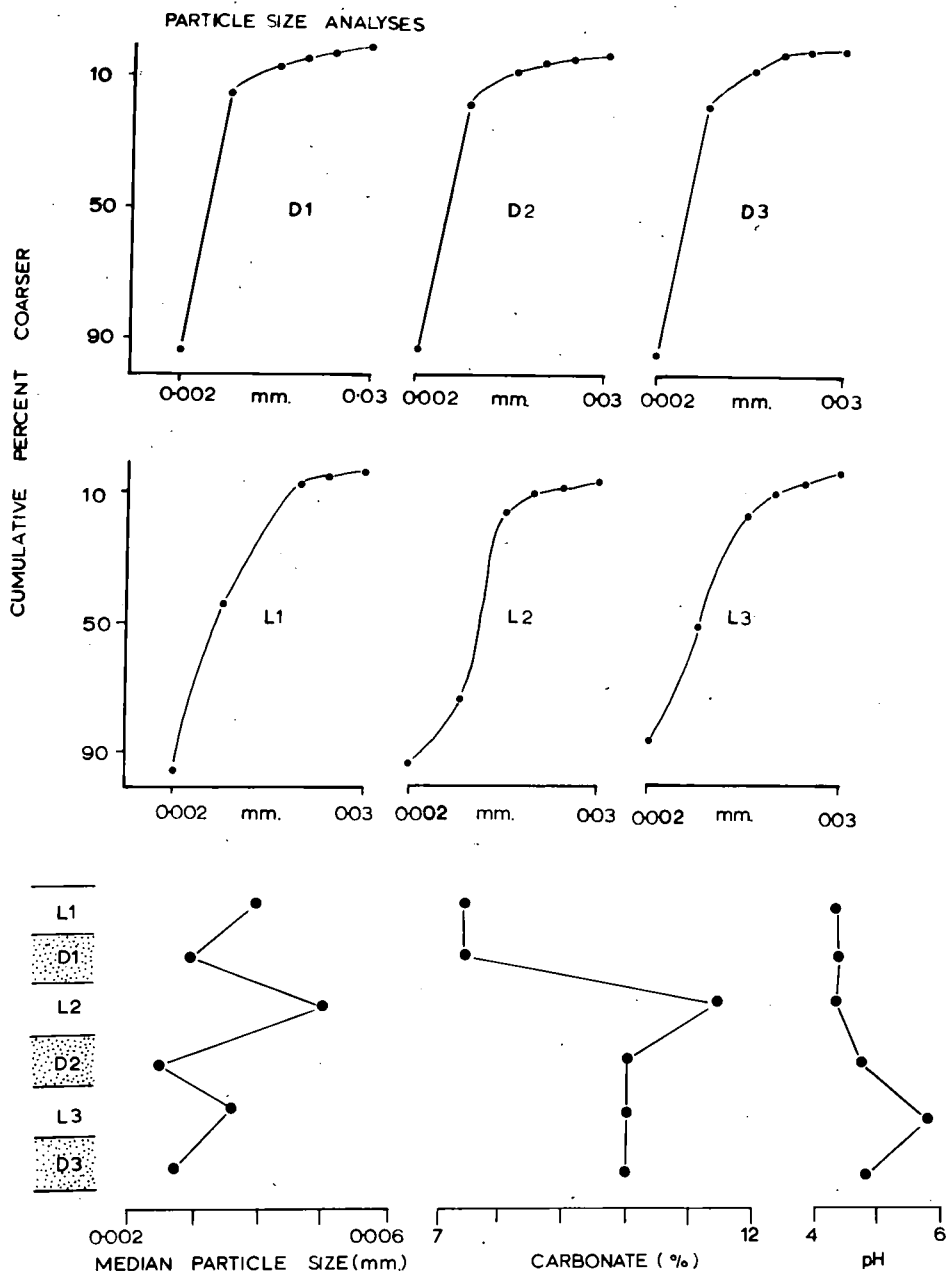
for he referred to a "buttery clay" but makes no further implication. With the possibility of these sediments being lacustrinal it was necessary to obtain some positive evidence, and samples were taken back to the laboratory for analysis. Furthermore, a laboratory analysis might indicate whether or not any pollen was present.

It was possible that these stone-free laminated sediments were not lake deposits, or water-laid deposits at all. Carruthers (1947-8 and 1953) has described a series of deposits which he considered reveal a complex process of deposition, occurring when an ice-sheet becomes stagnant and melts in situ. The sequence of drifts contains both stratified and unstratified deposits. The stratified undermelt deposits can be differentiated from lacustrine deposits by certain special characteristics. A complex layer of drift often contains a basal till overlain by stratified deposits and capped by another layer of till. The base of the stratified deposits frequently contains clay sediments. The term 'shear clay' has been used to describe these clays, which are claimed to consist of extremely sharply divided, but very thin layers of clay, giving a laminated effect. The laminae occur without rhythm and can be as fine as 0.01 mm. Small particles in the clay show equal flow around them, the underlying and overlying laminae passing under and over the particle respectively. Some of the layers show crumpling or minute faults. Such clays, formed as a result of the gentle melting out of sheared englacial detritus, have been described by Carruthers in lowland Durham and north Yorkshire.

In detail the nature of true glacial lake sediments varies considerably from shear clays although superficially, in the field, they may appear similar. Laminations are also highly characteristic of glacial lake floor environments. In these environments the laminations are caused by sudden changes in grain size between successive layers; there is also an accompanying colour change, the finest laminae being darker than the coarser. The regularly banded deposits have been termed 'rhythmites'; an individual pair consisting of one fine and one coarser lamina is known as a couplet. The dark layer of a couplet which may consist of very fine colloidal material represents a phase of slow deposition under very quiet water, such as would be expected if the lake were frozen at its surface and little or no meltwater

Fig. 8.10

# ANALYSES OF LAKE SEDIMENTS



L1,2 and 3 Darker Layers  
 D1,2 and 3 Lighter Layers

were entering. The light-coloured coarser member of the couplet represents more rapid accumulations of the lake floor sediments under more disturbed conditions. Kuenen (1951) has suggested that turbidity currents may help spread the sediment over the whole lake floor.

Since the first half of the nineteenth century a number of workers have suspected that the couplets in rhythmites were seasonal. De Geer, a pioneer worker in this field, introduced the term 'varves' to describe such annual couplets in 1912. Confirmation of the notion that most rhythmites are annual has come from pollen analyses which show evidence of seasonal changes in vegetation surrounding the lake during the time interval represented by one couplet.

The term varve is best kept for those rhythmites known to be annual for non-annual rhythmites are known to occur. They may arise from sudden fluctuations of discharge and load on the part of the meltwater stream and from warm and cold spells of a non-annual nature. It seems likely, however, that non-annual rhythmites are rare.

In the laboratory it was decided to attempt a particle size analysis on a small sample of the laminated sediment containing three couplets; the total thickness of the sample was 4 cm. each couplet being c. 1.3 cm. thick. The results of particle size analysis were plotted as cumulative curves on semilogarithmic graph paper (Fig. 8.10). In all six analyses silt sized material was dominant, clay sized material forming generally less than 10 per cent of the sample. Confirmation of the rhythmic nature of the sediment is seen in Figure 8.10 where the median particle size has been plotted for each lamination. A regular alternation is observed and in all cases the darker layers are finer than the lighter layers. The deposit has the nature of a rhythmic silt. Often the lighter laminae are observed to have a higher carbonate concentration than the darker laminae (Eden 1955). Carbonate analyses of the three couplets failed to reveal any significant differences. Possibly, if fresher samples could have been obtained, such a difference might have been detected.

Further confirmation of the rhythmic nature of the deposits is found in a study of a thin section of a couplet. A great deal of difficulty was encountered in trying to impregnate a representative couplet with a

suitable cement. There was a strong tendency for the material to collapse when immersed in the cementing medium. The impregnating technique used was modification of that described by Catt and Robinson (1961). The complete preparation of the thin section is described in appendix 7.

A problem which proved most difficult to overcome was that of grinding down the mounted sample to the required thickness. Often, when nearly suitable a coarse grain of quartz would free itself from the mounting medium and tear into the rest of the mount disturbing the fabric. Plate 8.1 is a photograph of a thin section of the junction between a dark and light lamina. This photograph clearly demonstrates the graded nature of the laminae. Fine silty material of the dark lamination can be seen to grade into an even finer material with many flat plates lying sub-horizontally. This is probably clay or colloidal material. Above this fine material, coloured dark brown in Plate 8.1, the material becomes immediately coarse. The classical interpretation of the coarse layer, is that it represents the beginning of a sedimentation cycle, probably starting in the spring with the melting of ice and the influx of sediment into the waterbody.

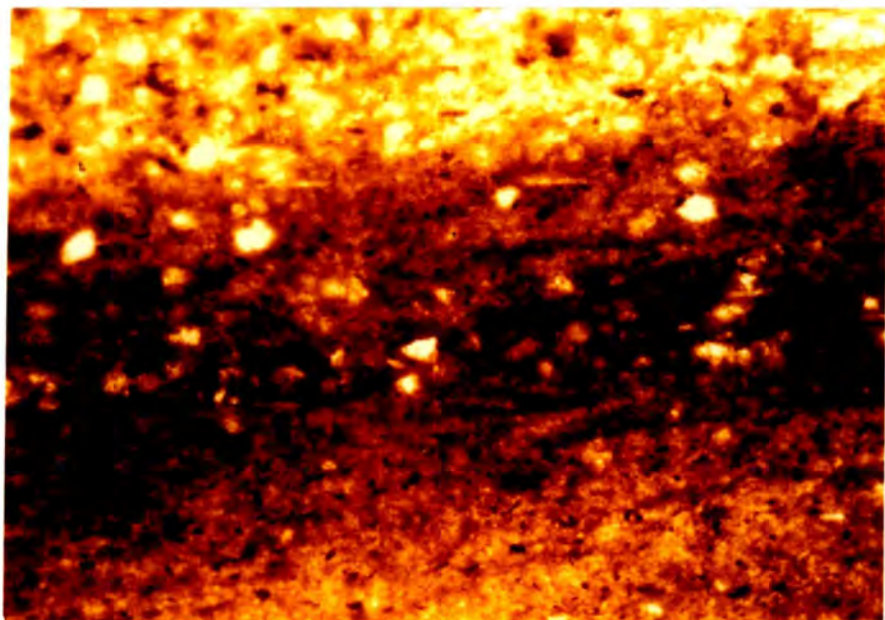
Several attempts were made, using hydrofluoric acid, to find pollen in these silts. Bodies of open water are known to act as very effective pollen traps and if pollen were present at the time of lake formation some might be found in the lake deposits. The results were most disappointing; no pollen, or indeed any traces of organic material were found. It is possible that at the time of lake formation the surrounding uplands were covered with permanent snow and ice, thus accounting for the lack of pollen. Alternatively, pollen might have been present but has been subsequently destroyed by oxidation.

### Conclusions.

The results presented in this chapter show how useful simple, although tedious, laboratory analyses can be in the description of tills from the north-west Alston Block. Moreover such simple objective descriptions pose new questions and new problems which might never have come to light had the analyses not been undertaken.

Particle size analyses have indicated that the tills deposited by ice which move across the northern Alston Block into County Durham was an

Plate 8.1



Photograph of a thin section of the rhythmic sediments of lacustrine origin found in the East Allen valley (magnifications x 50).

Fine silt particles are seen to grade gently into plates of silt and clay which were probably deposited in winter. Overlying the laminae formed in winter are coarse particles of quartz which were deposited in the summer. The abrupt junction between the winter and summer laminae is clearly seen.



evolving sediment, more variable near its bedrock source and seemingly less variable in the less erosional environment of lowland Durham.

Detailed comparisons with the results obtained from the stone counts indicated that there is a meaningful relationship between the bedrock lithologies and the particle size characteristics of the till. That there is such a positive relationship confirms the writer's view that the tills of the north-west Alston Block are to some extent ordered in their sedimentological characteristics.

## Chapter 9.

### Carbonate, pH, Ferric Iron and Coal Analyses.

#### Introduction.

In order to provide a fuller description of the tills of the north-west Alston Block it was decided to study several chemical properties of the till matrix. While much information is readily available from a study of the coarser fraction of the glacial sediments of the Alston Block it was felt that a study of the fine fraction would also yield interesting data. This chapter attempts to describe the results obtained from analyses of the carbonate, pH, ferric iron and coal content of the fifty-two till samples which were also subjected to coarse fraction analyses. Where possible the relationships between these and other variables are discussed.

#### 1. Carbonate Content.

One of the most common chemical analyses used in descriptions of the till matrix is the measurement of the amount of carbonate present. The most popular use of this technique is found in studies of weathering. Carbonate analyses down a sediment profile may indicate the depth to which leaching and removal of carbonates has occurred. By comparing the depths of carbonate removal several workers have attempted to correlate and date till sheets (Boulton and Worsley 1965; Dreimanis 1959; Merrit and Muller 1958). Flint (1949) has mentioned the problems involved in such methods and indicated that the amount of carbonate removal depends on the intensity of the leaching processes as well as the total time that such processes are active.

A further use of carbonate analysis has been illustrated by Andrews and Sim (1964) who, by studying the carbonate content in the till samples from north-west Baffin Island, worked out the source and direction of ice movement and the nature of dispersal of the ice at one stage of the glaciation.

As indicated in Chapter 2 limestone strata are well exposed on the Alston Block. It might be expected, therefore, that the local tills with

their incorporated limestone, would have a higher carbonate content than would the tills which were brought into the area by the incursive ice-sheets. To test this possibility fifty-two till samples were analysed using the rapid titration method of Piper (1942) (Appendix 4). Samples for carbonate analysis were taken from the unweathered matrix material which had previously been separated in the course of particle size analysis (Chapter 8).

Dreimanis (1960) in a study of the significance of carbonate determinations in a till matrix considered that analyses of the unweathered matrix had the following advantages. Firstly, it has a relatively constant composition. Secondly, it provides a good reflection of the more distant lithologies, and thirdly, only small samples are needed for analysis. The results of the analyses for the fifty-two samples from the north-west Alston Block are shown in Table 9.1 and are illustrated in Figure 9.1.

The absolute range of carbonate for all the samples analysed was from 1 to 32.5 per cent. Forty per cent of all the samples had a carbonate content of less than 5 per cent, while only one sample had a carbonate content of more than 30 per cent.

Inspection of the histograms for the local erratic-free and erratic-containing tills (Fig. 9.1) shows that both groups of till have similar modal values, (0-5 per cent).

Probably most of the carbonate in the tills is derived from limestone but secondary sources include the breakdown of carbonate bearing minerals in igneous and metamorphic rocks and also carbonate forming a cement in certain sandstones. The comparatively large number of samples, within the group of tills containing erratics, which contain from 5 to 20 per cent carbonate is explicable if reference is made to likely directions of ice producing such tills. It has been shown in Chapter 2 that relatively massive limestones skirt the Lake District and it is probable that by the time the ice had reached the Alston Block much of this material would have entered the matrix component of the deposits. The relatively high carbonate values might well, therefore, be associated with a more distant lithology as suggested by Dreimanis (1960).

Although the local tills appeared, from stone counts, to contain more limestone, Figure 9.1 illustrates that they do not have an appreciably

# CARBONATE CONTENT OF THE TILLS.

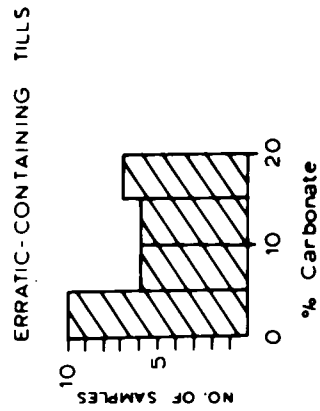
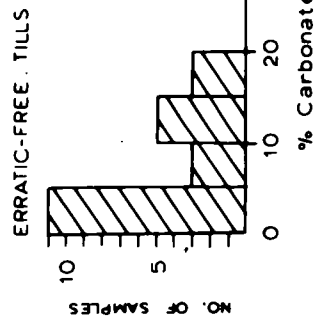
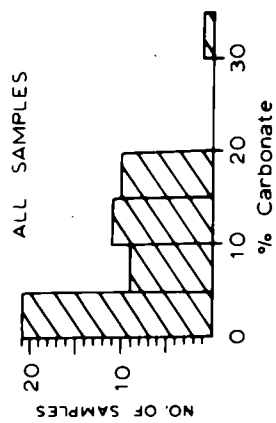


Fig. 9.1

higher carbonate content. If it is possible to argue that the matrix represents the more distant lithologies then the unexpectedly low carbonate values for the local tills could have resulted from the converse of this argument. The local tills, by their very nature, are not far travelled and therefore the limestone identified in the coarser fraction was not so efficiently incorporated into the matrix of the tills. It is of interest to mention here that the highest carbonate content determined, 32.5 per cent (Site 4, Table 9.1) was for local till. However, such a high carbonate content was not unexpected. This sample was obtained from an exposure just down stream of the Great Limestone outcrop and the till face abounds with large striated limestone boulders. A stone count for this sample indicated that the limestone made up some 67 per cent of the total lithology of the till.

To determine whether or not the erratic-free tills could be distinguished from erratic-containing tills in terms of their carbonate contents it was decided to test the results using the Kolmogorov-Smirnov two-sample test.

#### Comparisons of carbonate contents.

Calculated D	12.6
Computed Chi square	0.814
Tabulated Chi square (0.05 significance level)	5.99

The null hypothesis that the erratic-free tills contain more carbonate than the erratic-containing tills is therefore rejected at the 95 per cent level of probability.

#### 2. pH.

The chemical 'reaction' of the sediment sample frequently determines the sort of changes which can take place in it and is a quantity which it is generally desirable to know at the outset of any chemical examination (Cornwall 1966).

The reaction of a sample is expressed more exactly by the hydrogen-ion concentration denoted by the symbol 'pH'. This is a measure of the absolute degree of acidity or alkalinity of a solution, and is, the negative exponent of the actual concentration of  $H^+$ -ions in grammes per litre. Pure water

contains  $10^{-7}$  (1/10,000,000) grammes of  $H^+$ -ions per litre and is a standard of chemical neutrality. More  $H^+$ -ions than this in a solution would make it acid in reaction.

The pH may be said to represent the interplay of a great many factors such as the carbon dioxide concentration in the pores of the sediment, the presence of substances capable of changing their state of oxidation or reduction, the concentrations of ions in the pure water, the vegetation and drainage. It therefore represents the contemporary chemical environment, rather than reflecting the sediment history.

It is worthwhile to mention one or two important effects that pH has in terms of the chemical analyses described in this chapter. Free calcium carbonate is in equilibrium with atmospheric  $CO_2$  when the pH is close to 8.4. When dissolved in water carbon dioxide forms a weak acid solution ( $H_2CO_3$ -carbonic acid) which is capable of attacking calcium carbonate and converting it into soluble calcium bicarbonate. With a pH above 8.4 calcium carbonate is precipitated, while with lower pH's, with more  $H^+$ -ions available to combine with carbon dioxide and form carbonic acid, calcium carbonate is removed in solution.

It is known that pH also plays an important role in governing the mobility of iron. In general terms iron is immobile at pH's above 6.6. Below a pH of about 5.0 many iron minerals are colloidal sols and are, therefore, rapidly translocated from the sediment.

The pH of the till samples was measured electrometrically using a glass electrode. The results of the fifty-two analyses are shown in Table 9.1 and illustrated in Figure 9.2.

The absolute range of pH values for the tills of the north-west Alston Block is from 4.0 to 8.3 and it is evident that the majority of the tills have a pH of 7 or more. It should be noted here that many of the soils overlying the tills in the Alston Block have low pH's, from 4 to 5, reflecting the acid conditions formed by the callifugeous vegetation and the high rainfall.

Table 9.1. Results of Carbonate, pH, Ferric Iron, Coal and Munsell colour determinations.

<u>Sites *</u>	<u>CaCO<sub>3</sub> %</u>	<u>pH</u>	<u>Ferric Iron %</u>	<u>Coal %</u>	<u>Munsell colour.</u>
1.	16.7	7.1	1.028	0.28	10 YR 3/1 (very dark grey)
2.	1.0	7.3	1.200	0.24	10 YR 3/1 (very dark grey)
3.	14.5	7.3	1.183	0.36	10 YR 4/1 (dark grey)
4.	32.5	8.3	0.600	0.24	10 YR 2/2 (very dark brown)
5.	1.5	7.7	1.670	0.16	10 YR 3/2 (very dark greyish brown)
6.	4.0	7.4	1.154	0.13	10 YR 3/3 (dark brown)
7.	5.0	7.7	1.085	0.26	10 YR 3/2 (very dark greyish brown)
8.	15.5	6.9	1.183	0.23	10 YR 3/1 (very dark grey)
9.	13.0	6.4	0.914	0.07	5 YR 3/4 (dark reddish brown)
10.	17.2	6.5	1.171	0.16	10 YR 3/3 (dark brown)
11.	2.2	6.8	1.131	0.18	10 YR 2/2 (very dark brown)
12.	12.5	7.3	1.028	0.28	10 YR 3/2 (very dark greyish brown)
13.	12.5	7.3	1.183	0.05	10 YR 4/2 (dark greyish brown)
14.	4.5	7.3	1.286	0.29	10 YR 3/2 (very dark greyish brown)
15.	1.7	7.3	1.182	0.11	10 YR 5/1 (grey)
16.	18.0	7.2	1.182	0.14	10 YR 3/2 (very dark greyish brown)
17.	4.0	7.2	1.182	0.15	2.5 YR 3/2 (very dark greyish brown)
18.	2.7	7.1	0.503	0.06	10 YR 3/2 (very dark greyish brown)
19.	11.0	7.1	1.314	0.14	2.5 YR 4/2 (dark greyish brown)
20.	15.0	7.4	1.028	0.29	10 YR 4/3 (dark brown)
21.	17.2	6.0	1.183	0.13	10 YR 4/2 (dark greyish brown)
22.	9.5	7.7	1.091	0.03	10 YR 3/2 (very dark greyish brown)
23.	7.2	7.1	1.091	0.03	10 YR 3/1 (very dark grey)
24.	2.6	7.3	1.423	0.29	10 YR 2/2 (very dark brown)

\* Site numbers are similar to those indicated in Table 7.1.

Cont. Table 9.1. Results of Carbonate, pH, Ferric Iron, Coal and Munsell colour determinations.

<u>Sites *</u>	<u>CaCO<sub>3</sub>%</u>	<u>pH</u>	<u>Ferric Iron %</u>	<u>Coal %</u>	<u>Munsell colour.</u>
25.	9.0	7.3	1.828	0.09	10 YR 3/2 (very dark greyish brown)
26.	5.0	7.3	1.028	0.20	10 YR 3/2 (very dark greyish brown)
27.	18.0	7.5	1.291	0.14	10 YR 3/3 (dark brown)
28.	12.5	7.2	1.205	0.11	10 YR 4/2 (dark greyish brown)
29.	11.7	7.4	1.166	0.36	10 YR 3/2 (very dark greyish brown)
30.	4.5	7.4	1.314	0.16	10 YR 4/2 (dark greyish brown)
31.	18.5	7.2	1.300	0.04	10 YR 2/2 (very dark brown)
32.	1.0	7.6	0.857	0.19	5 YR 3/4 (dark reddish brown)
33.	1.0	8.3	1.200	0.07	10 YR 3/4 (dark yellowish brown)
34.	3.7	6.9	1.171	0.03	10 YR 3/2 (very dark greyish brown)
35.	18.0	7.4	1.550	0.11	10 YR 3/3 (dark brown)
36.	12.0	7.2	1.291	0.13	10 YR 3/3 (very dark greyish brown)
37.	3.2	7.4	1.034	0.13	10 YR 3/2 (very dark greyish brown)
38.	9.0	7.8	1.314	0.09	10 YR 3/1 (very dark grey)
39.	13.0	7.7	1.771	0.13	10 YR 2/2 (very dark brown)
40.	19.0	8.3	1.028	0.27	10 YR 2/2 (very dark brown)
41.	11.0	4.5	1.177	0.12	10 YR 3/2 (very dark greyish brown)
42.	14.0	8.0	0.471	0.01	2.5 YR 4/2 (dark greyish brown)
43.	5.8	6.2	1.257	0.15	10 YR 3/3 (dark brown)
44.	5.2	6.4	1.028	0.13	5 YR 3/2 (dark reddish brown)
45.	2.8	7.7	0.977	0.04	10 YR 3/3 (dark brown)
46.	2.5	5.0	0.314	0.07	10 YR 4/2 (dark greyish brown)
47.	2.5	5.2	1.183	0.08	10 YR 4/2 (dark brown)

\* Site numbers are similar to those indicated in Table 7.1.



Cont. Table 9.1. Results of Carbonate, pH, Ferric Iron, Coal and Munsell colour determinations.

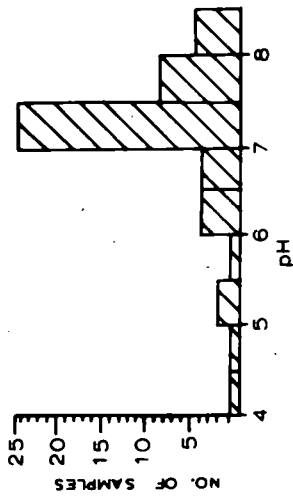
<u>Sites *</u>	<u>CaCO<sub>3</sub> %</u>	<u>pH</u>	<u>Ferric Iron %</u>	<u>Coal %</u>	<u>Munsell colour.</u>
48.	1.0	4.0	1.028	0.21	10 YR 3/2 (very dark greyish brown)
49.	6.0	8.2	0.977	0.08	5 YR 3/2 (dark reddish brown)
50.	1.0	5.7	0.880	0.15	5 YR 4/6 (yellowish red)
51.	3.8	7.7	1.257	0.32	10 YR 3/3 (dark brown)
52.	3.8	7.4	0.977	0.50	10 YR 3/4 (dark yellowish brown)

\* Site numbers are similar to those indicated in Table 7.1.

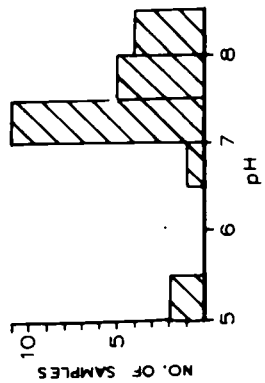
Fig. 9.2

# PH VALUES OF TILLS

ALL SAMPLES



ERRATIC-FREE TILLS



ERRATIC-CONTAINING TILLS

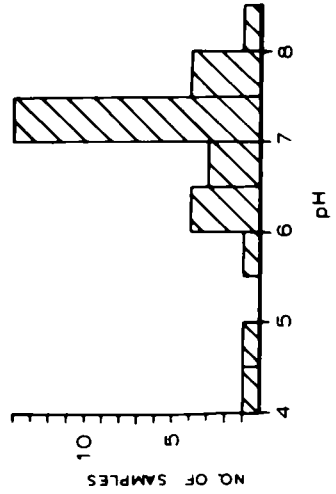
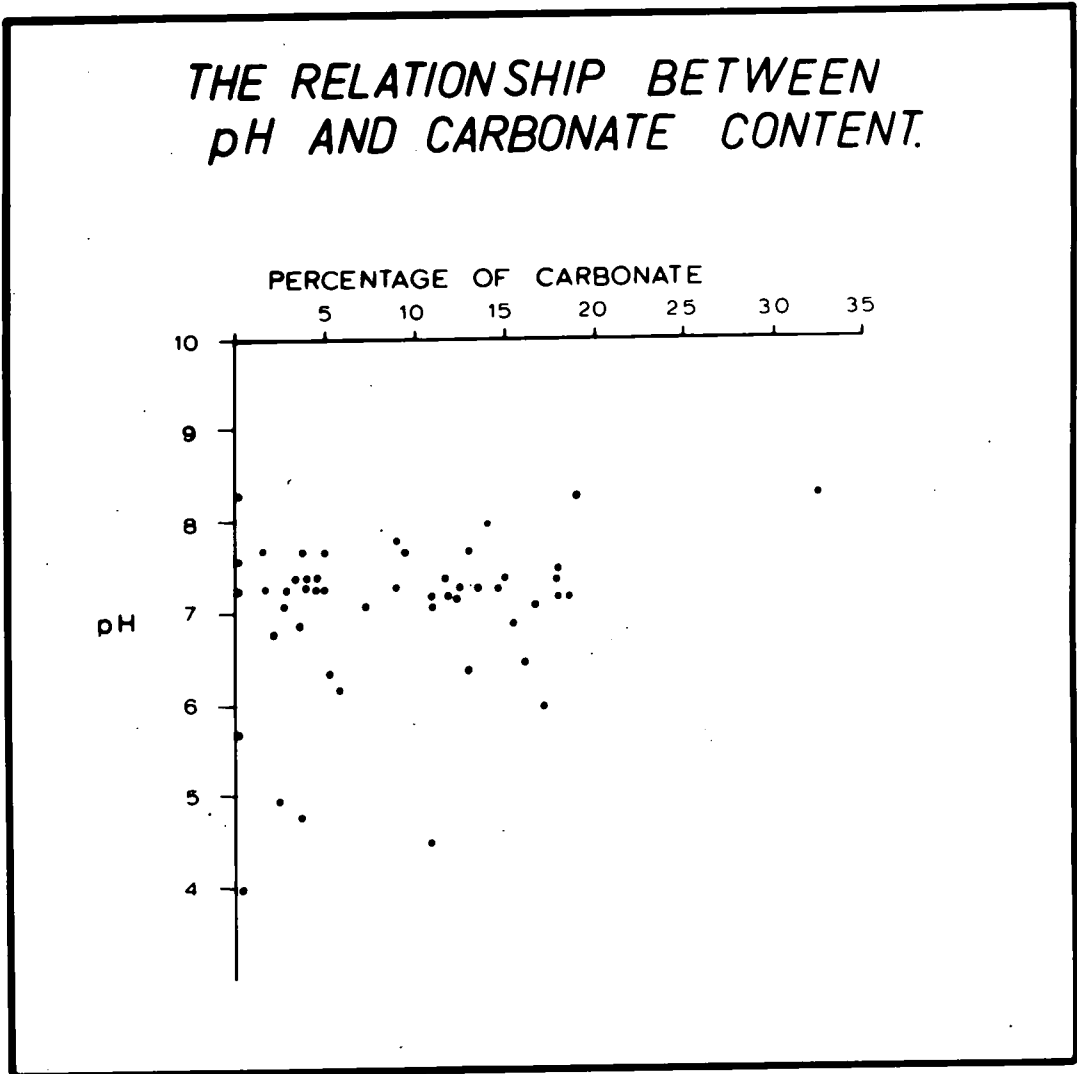


Fig. 9.3



There would appear to be no significant difference in pH between the erratic-free and erratic-containing tills.

Comparison pH values.

Calculated D	21.7
Computed Chi square	2.414
Tabulated Chi square (95 per cent level)	5.44

The null hypothesis that the erratic-free tills have higher pH values than the erratic-containing tills is therefore rejected at the 95 per cent level of probability.

The relationship between the pH and the carbonate content of the tills of the north-west Alston Block is shown in Figure 9.3. It can be seen that the higher carbonate values are associated with higher pH's. Carbonate values of 5 per cent and less, however, are found within a wide range of pH values (from 4 to 8.3).

An examination of the stone count data indicated that many of the samples without limestone also had relatively lower pH values. This relationship was confirmed by a coefficient of correlation of 0.360 (significant at 95 per cent level of probability), indicating a statistically significant, although far from direct, relationship between percentage limestone in the stone count and pH. The two samples which have pH values of less than 5 (Fig. 9.2) were found not to contain limestone in the stone count. These two samples, therefore, might initially have had matrices deficient in carbonate and therefore have correspondingly low pH's, or have to some extent been leached in Post-glacial times.

3. Iron Content.

One of the most obvious differences to the traveller coming from the Vale of Eden into the Alston Block is the dramatic change which occurs in the colour of the soils. In the Eden valley the soils are distinctly red while those of the Pennine Uplands are drab in comparison. This marked difference in colour is also found in the tills of the two areas and reflects the difference in bedrock between the two areas (Chapter 2). From observations in the field it was obvious that the colour changes in the tills,

as examined from west to east, were gradual, reflecting the dilution of the red tills as they become more and more mixed with local bedrock of the Alston Block. For instance, at sites 44, 45 and 5 (Table 9.1 and Fig. 7.1) lying in a west-east transect the Munsell colours of the tills were respectively dark reddish brown (5YR 3/2), dark brown (10YR 3/3) and very dark greyish brown (10YR 3/2).

Dunham (1953) concluded that the red colouration of the desert formations of Permian and Triassic age was due to iron oxide which was erosively removed from the hot humid upland soils which surrounded the Permo-Triassic Deserts. It is reasonable to suppose, therefore, that the red colouration of the tills which were brought into the Alston Block from the west is due to the incorporation of Permo-Triassic material. The writer considered, therefore, that the red tills might contain higher percentages of ferric iron than the duller-looking local tills.

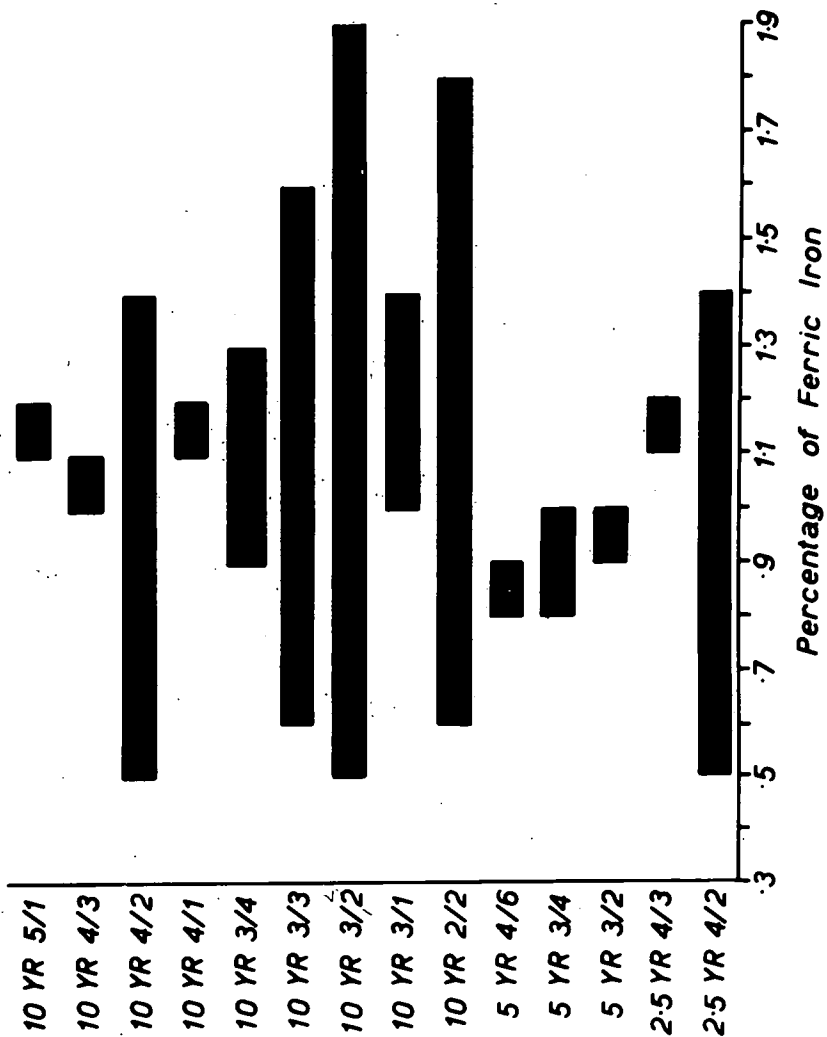
To test this notion it was decided to analyse the ferric iron content of the till matrices and to compare the results with the colour of the till as recorded in the field with a Munsell colour chart.

The ferric iron content was estimated colorimetrically using thioglycolic acid (Cornwall 1966) - (Appendix 5). The results of the ferric iron determinations and each sample's corresponding Munsell colour are shown in Table 9.1.

It can be seen from Table 9.1 that values range from 0.134 to 1.771 per cent. To determine whether or not the Munsell colour of the till was related to the ferric iron content the range of iron content was plotted for each Munsell chart division (Fig. 9.4). The results provided by this figure were initially surprising. It was certainly not true, as the writer had previously thought, that the redder, erratic-containing, tills contained more ferric iron. Many samples with a hue of 10 YR (dark brown to dark greyish brown) contained more ferric iron than those with a hue of 5 YR (reddish brown). If, then, the local tills contained more ferric iron than their redder counterparts where was the ferric iron derived from? A partial explanation to this question was given by correlating the ferric iron content of the fifty-two till samples with their stone counts. As the matrix of the till is initially derived from the country rock then so too must the iron

Fig. 9.4

**THE RANGE OF FERRIC IRON CONTENT  
AND ITS RELATIONSHIP TO THE MUNSELL  
COLOUR OF THE TILLS OF THE ALSTON BLOCK.**



content of the till. The only meaningful correlation, and this was at a highly significant level, was that between ferric iron content and shale content of the till.

$r$  value shale/ferric iron = 0.600 (significant at .01 per cent level)

This correlation as well as being statistically significant, makes good sense geologically; most shales contain relatively large amounts of iron oxides (Milner 1940).

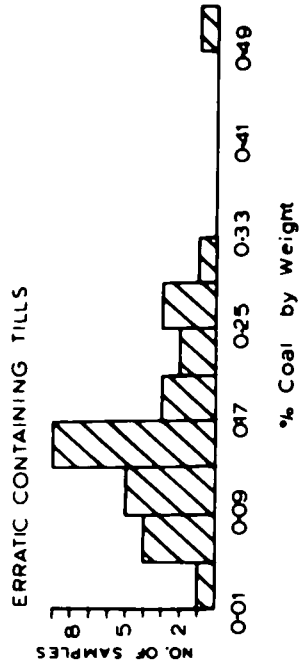
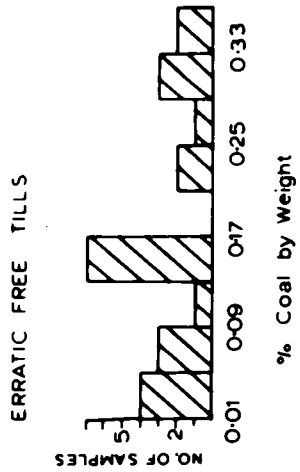
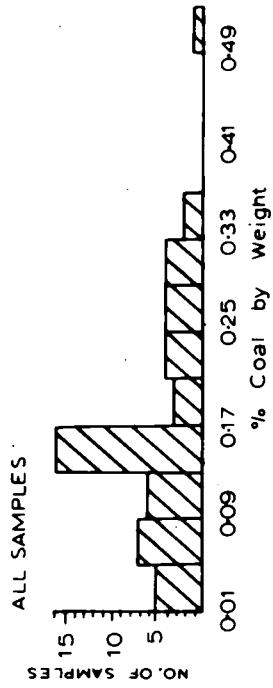
A brief review of the literature indicated that not all iron oxides are red. Maghemite is typically brown, lepidocrocite is most commonly reddish brown, goethite is often yellow or brown and hematite is dull to bright red. This short list would seem to indicate that it may well be a specific type of ferric oxide, namely hematite, rather than the total amount of ferric oxide, which is responsible for the colouration of the erratic-containing tills.

#### 4. Coal Content.

Thin coal seams are ubiquitous throughout the north-western Alston Block. For this reason it was thought that the local tills of the Alston Block might differ in their coal content from the foreign tills. A method of separating the coal from the till matrix has been described by Beaumont (1967) (Appendix 6). This method was used to analyse 52 samples of till from the Alston Block. The results are shown in Table 9.1, and are illustrated in Figure 9.5. All the samples analysed contain some coal. The absolute range of values is from 0.01 per cent to 0.502 per cent by weight. Figure 9.5 also shows that, in terms of coal content it is impossible to distinguish the local tills from other tills found on the Alston Block. The reason for the presence of coal in the foreign till is of interest. Presumably these tills picked up Pennine sediments as soon as they encroached onto the Alston Block. It is likely that ice, streaming from the Eden valley over the Alston Block was very erosive and the rapidly incorporated Pennine lithologies in the tills bear witness to this. All samples had much less coal than the lower till of lowland Durham. No sample of the Lower till in the Wear Lowlands, for instance, has a coal content of less than 0.71 per cent (Beaumont 1967). This increased content of coal is a direct reflection of the movement of ice over Coal Measure rocks which outcrop to the east of the area at present under discussion.

Fig. 9.5

# COAL CONTENT OF THE TILLS





## Conclusion.

One of the primary objectives in these analyses of the till matrix was to provide objective data about the tills of the Alston Block. Such data ~~are~~ invaluable in the comparisons of till deposits between areas. By an understanding of the similarities and the differences of such analyses for other areas we learn more about the processes of glacial erosion and deposition.

In themselves, these texts have indicated relationships between the till matrix and the coarser elements of the till. Such relationships add further evidence to the contention that tills are not haphazard assemblages but are an organised sediment.

## Chapter 10.

### X-ray Diffraction and Heavy Mineral Analyses.

#### Introduction.

Studies of the clay mineralogy and of the petrology of the fine sand fraction have become standard techniques in analyses of sediments. The purpose of such analyses on the tills of the north-west Alston Block is two-fold. Firstly, the tills have not been previously analysed and it was therefore necessary to obtain some basic data. Secondly, it was required to know whether or not such analyses would be useful in the study of provenance. For convenience this chapter is sub-divided into two sections:

- a. X-ray mineralogy of the clay fraction.
- b. Heavy mineral analyses of the fine sand fraction.

#### Section a. X-ray Mineralogy.

Little attention has been paid by British geomorphologists to the clay fraction of glacial tills. In North America many interesting studies of the major continental till sheets have been made, attention having been particularly focussed on weathering sequences but provenance has also been considered. (Droste 1956a; Droste 1956b; Bhattacharya 1962; Willman, Glass and Frye 1963).

A few studies of the clay fraction of British glacial tills have been made, however, particularly by pedologists, (Perrin, 1956; Mitchell and Mitchell 1956 and Searle 1968) and analyses of the clay mineralogy of tills within the context of glacial geomorphology have been undertaken by Beaumont (1967).

#### Recognition of clay minerals.

The analysis of crystalline components in a sediment by X-ray diffraction is analogous to the finger print method of identification of humans. In X-ray diffraction analysis two parameters are determined. These are the spacings between the planes of atoms in the crystals and the intensities of the X-ray diffractions from the corresponding planes. These

parameters are unique for each crystal species.

The X-ray diffraction characteristics of the main mineral species found in the less than one micron fraction are briefly described. The terminology followed is that based on the proposed classification scheme for clay minerals and related phyllosilicates issued by the Nomenclature Subcommittee of the Comite International pour l'Etude des Argiles (Brindley 1966; Brindley 1967).

1. Clay minerals.

a. Smectites (Montmorillonite-Saponite Group).

The Smectites are 2:1 layer silicates. The layers of  $\text{Si}(\text{O},\text{OH})_4$  tetrahedra sandwich a sheet of  $\text{M}(\text{OH})_6$  octahedra, having the composition  $\text{M}(\text{OH})_2$  or  $\text{M}(\text{OH})_3$  depending on whether M represents a divalent (Mg, Fe, Mn etc.) or a trivalent (Al, Fe, Mn) cation (Mackenzie and Mitchell 1966). X-ray patterns of Smectites samples are generally of poor quality and diffuse. From the viewpoint of properties and analytical recognition the most distinct feature of the smectites is that water and organic liquids may penetrate between the layers. Smectites form complexes with polar organic compounds; the complexes formed with glycol have a stable basal spacing and are, therefore, of use in X-ray analysis. Treatment of smectite with glycerol provides a characteristic sharp reflection at 18 or 17A respectively. Treatment with such organic compounds permits the detection of small amounts of the mineral which would otherwise be missed in complex mixtures. Upon heating to 550° C smectites collapse to an anhydrous mineral with a value of 9 to 10A for the first order basal reflection.

b. Mica-Like Clay Minerals.

Muscovite and its derivatives are characterised by the following basal reflections which are not affected by glycolation: 10.0, 5.0, 3.3 and 2.5A. When the basal reflections are symmetric and intense, and heat treatment does not affect the relative intensities or positions of the peaks the mineral is called muscovite (Brown 1961). The term illite is used as a collective name denoting all 10A non-expanding clay minerals in argillaceous sediments (Gaudette et al, 1966). Orientated slides of illite show a relatively sharp basal reflection which becomes slightly sharper after heat

treatment. When the illite contains a larger amount of expansible mixed layer material there will be some asymmetry in the first order basal reflection, a definite sharpening of the basal reflection after heat treatment and an expansible phase after saturation with glycerol. It is practically impossible to determine biotite in the presence of chlorite and illite (Brown 1961).

c. Chlorites.

Chlorite exhibits an integral series of basal reflections with a first-order reflection of 14A. The spacings are not affected by glycerolation. The identification of the various species of chlorite is usually very difficult and may be impossible. Careful heating can yield valuable data for identifying chlorites. Generally upon heating the intensity of the 001 chlorite reflection increases, combined with a slight shift of higher angles. Poorly crystalline material may decompose completely on heating to 450°C (Grim and Johns 1954).

d. Kandites. (Kaolinite and Halloysite).

In principle these minerals are identified by their highly characteristic diffraction maxima at 7.1, 3.5 and 2.38A. With the exception of halloysite their reflections are unaffected by glycerolation. Between 400 and 450 c. the kandite peaks show a slight decrease in intensity; at 500 c. they disappear completely. Disorder in the kandite lattice produces blurred and weak reflections. The group of reflections between 4.18 and 4.13A particularly show the change to lower crystallinity.

e. Vermiculites.

The identification of vermiculite frequently presents a problem because of the variable nature of this material. Vermiculite, which is easily derived from biotite by weathering, may be distinguished from normal smectite and chlorite by comparing the patterns of the untreated and glycerolated samples. Smectite swells to a basal spacing of c. 17.7A; the spacing of vermiculite and chlorite will remain 14A. After heating to c.500 C, the spacing of smectite and vermiculite will shift to c.10A whereas that of the chlorite remains unchanged.

f. Interstratified or mixed-layer clay minerals.

Besides mixtures of discrete clay minerals particles another type

of mixture exists: the interstratification of the phyllosilicates, in which the individual layers are of the order of one single or a few aluminosilicate sheets. The layering can either be regular or random in pattern. The recognition of regular mixed-layer mineral presents little difficulty since the 001-reflections are always greater than 20A (the sum of the 001-reflections of the individual components in the mineral mixture, e.g. 14A-chlorite + 14A-vermiculite = 28A corrensite). Weaver (1956), in particular, has worked on the identification of mixed layer minerals with random interstratification. By far the most abundant mixed-layer minerals found in sediments are random mixtures of illite and montmorillonite. In samples treated with glycerol, the 001 peaks of illite-montmorillonite mixed-layer minerals have d-values which lie between the  $d_{001}$  of illite (10A) and glycerolated montmorillonite (17A).

## 2. Non-Clay Minerals.

Several non-clay minerals are often found in the less than 1 micron fraction.

### a. Quartz.

Quartz appears to be ubiquitous mineral species. In a diffractometer trace quartz is easily recognized by the occurrence of a peak at 3.34A, 4.26A and 1.82A. The peak spacing is not affected by glycerolation or heat treatments of the sample.

### b. Felspars.

Felspars frequently appear in fine fraction samples and their X-ray identification offers little difficulty. All felspars show three strong reflections in the region between 3.28 to 3.16A. Plagioclase felspars can be identified and thereby distinguished from the alkali felspars by the following reflections (Goodyear and Duffin, 1954):

- i. two strong reflections in the range 3.17 - 3.22A.
- ii. a medium reflection line at 6.4 - 6.5A.
- iii. three medium to strong peaks at 4.03 - 4.05, 3.74 - 3.78, 3.61 - 3.67A.

c. Carbonates.

Carbonates found in the clay fraction are most likely to be of the calcite structural type (Brown 1961). Calcite is recognized by peaks at 3.034, 2.285 and 2.095A. Dolomite is recognized by three peaks at 2.886, 2.192 and 1.786A.

d. Iron Minerals.

One of the aims of the X-ray diffraction analysis of the glacial deposits of the Alston Block was to try and establish the species of iron oxides present in the clay fraction. The iron oxides are a major factor influencing the colour of such deposits. Van Houten (1961) recognises four important colour-determining ferric oxides which are commonly found in unconsolidated deposits.

- i. Lepidocrocite is recognised by three basal reflections at 6.26, 3.29 and 2.47A. On heating to high temperatures (170-400 C) lepidocrocite dehydrates to maghemite.
- ii. Maghemite may be recognized by three peaks at 2.514, 1.474 and 2.95A. At temperatures above 400 C. maghemite rapidly converts to hematite.
- iii. Goethite has three principal reflections at 4.21, 2.69 and 2.44. On heating to temperatures above 250<sup>o</sup> C. goethite dehydrates to hematite.
- iv. Hematite is one of the most stable iron oxides and is recognized by peaks at 2.69, 2.514 and 1.692A. On heating the hematite structure is rapidly perfected.

Analytical Methods.

As X-ray methods are too insensitive to identify small amounts of minerals present in the clay fraction when large quantities of coarser material are also present, the clay fraction must be isolated before X-ray analysis (Jackson, 1964).

Samples of the less than 1 micron fraction of the till samples were obtained by mechanically dispersing the sediment in distilled water. After 48 hours the top 10 cm. of the filtrate were syphoned off and gently dried. Mechanical dispersion, using an electric mixer, was preferred to the use of a chemical dispersion agent such as sodium metaphosphate, sodium pyrophosphate and sodium ethylenediamine tetra-acetate. Such dispersing agents have been

shown to react with and alter naturally occurring clay minerals (Gjems 1967).

Four preparations were analysed for each till sample. Non-orientated samples were easily prepared by packing the clay sample into a standard Philips specimen holder. Orientated samples were prepared by pipetting approximately 20 mg. of suspended clay material onto a glass slide (Bradley et. al. 1937). Sedimentation and drying took place overnight at room temperature. Glycerol-saturated samples were prepared by placing the same slide in a vacuum desiccator over glycerol for at least 48 hours (Gjems, 1967). After X-ray examination the glass slide was placed in a muffle furnace at 550°C for one hour. During this treatment the glass slide must lie on a completely level surface, otherwise the glass is easily deformed thereby curving the clay surface which results in a weakening of the intensity of the basal reflections. The X-ray examination was made as soon as possible after ignition of the sample.

X-ray examination was made on a Philips X-ray diffractometer belonging to the Department of Geography, University of Durham. Nickel filtered copper k-alpha radiation was used and the preparations were scanned at the rate of 1 degree 20 per minute.

#### Results of the Analyses.

Five samples were analysed by this method. The five samples were chosen so as to be reasonably representative of the different types of till found in the field area.

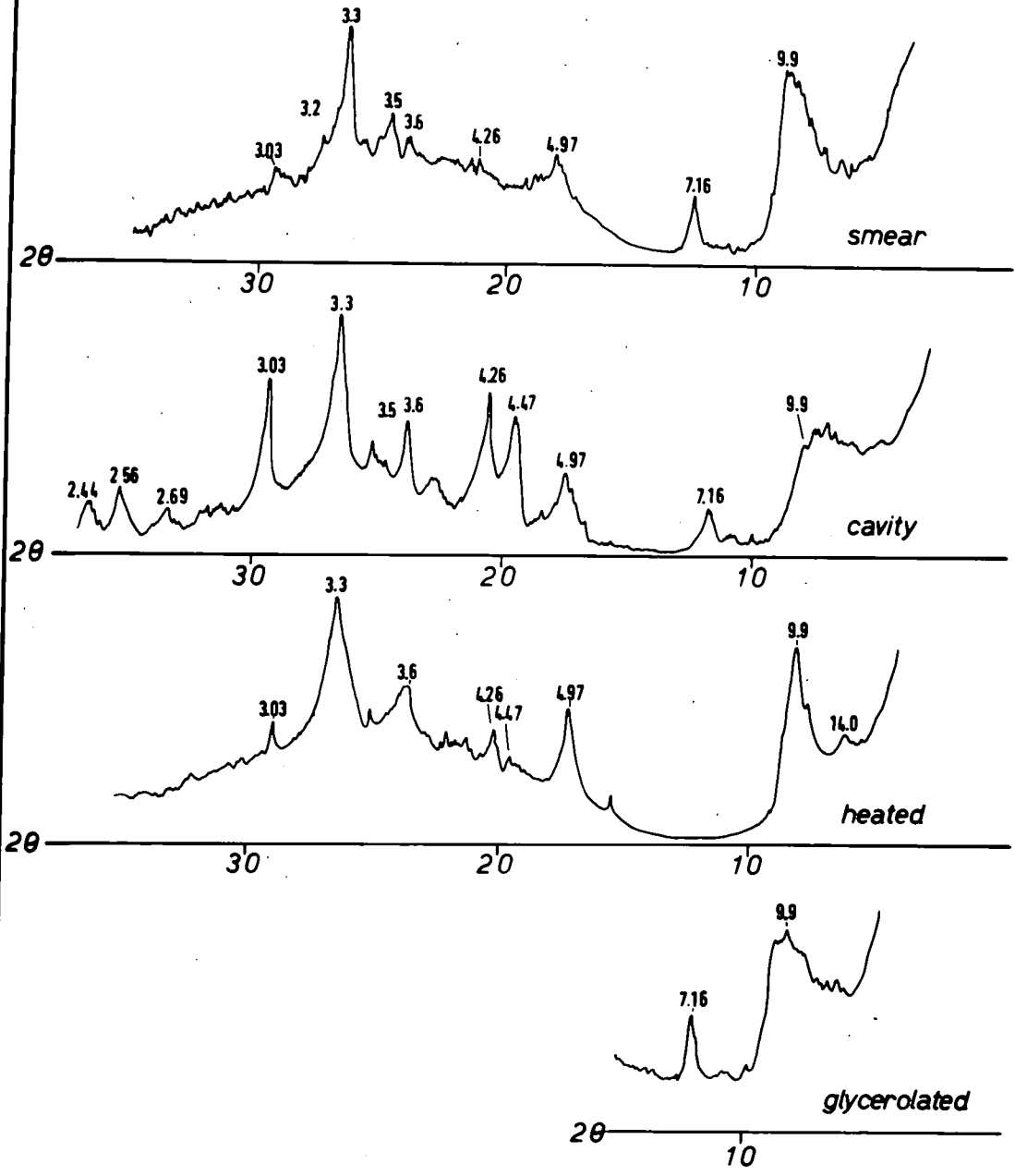
#### Sample 1. (Fig. 10.1).

This sample was obtained from an exposure at 713469, a little way north of Alston town. A stone count indicated that this till was very rich in limestone and the bulk of this deposit was probably eroded from outcrops of massive limestone which occur in the vicinity.

Illite was detected in this sample by the presence of a peak at 9.9, 4.97, and 4.47A (Fig. 10.1). The asymmetry of the 9.9A peak is probably due to the presence of illite/mixed-layer minerals and to a certain amount to the hydration of the illite itself. This was confirmed in the heated sample where the illite peak has become more symmetrical due to the removal of water from the mixed-layer component.

Fig. 10.1

# X-RAY DIFFRACTION CURVES FOR SAMPLE I







The presence of a kandite (kaolin) was indicated by peaks at 7.16 and 3.5A which are unaffected by glycerolation and are destroyed on heating the sample to 550°C.

The small amount of chlorite was detectable in this sample. Although a clear peak at 14A is not seen on either the cavity or smear traces (Fig. 10.1) a 14A peak does become obvious in the preparation heated to 550°C. The appearance of such a chlorite peak on heating appears to be quite typical (Quakernaat, 1968). Glycerolation failed to reveal any expanding minerals and it must be concluded that they are either present in very small, undetectable quantities, or absent altogether.

An intense peak at 3.03A indicated the presence of calcite. This was not unexpected in a sample containing so much limestone. No strong feldspar peaks were found in the diffraction traces. Peaks indicative of a feldspar seen on the smear trace at 3.2 and 3.6 (Fig. 10.1). It was not possible to differentiate plagioclase from alkali feldspars in this sample.

Strong peaks at 3.34 and 4.26A are a clear indication of the presence of quartz in the clay fraction. Two peaks at 2.69 and 2.44A suggest the presence of goethite, a hydrated ferric oxide. Both peaks disappeared in the heated trace confirming the identification. Van Houten (1961) has suggested that goethite is the pigment of most yellow and brown soils and its appearance in this sample is thus in harmony with visual assessment of the colouration.

#### Sample 2. (Fig. 10.2).

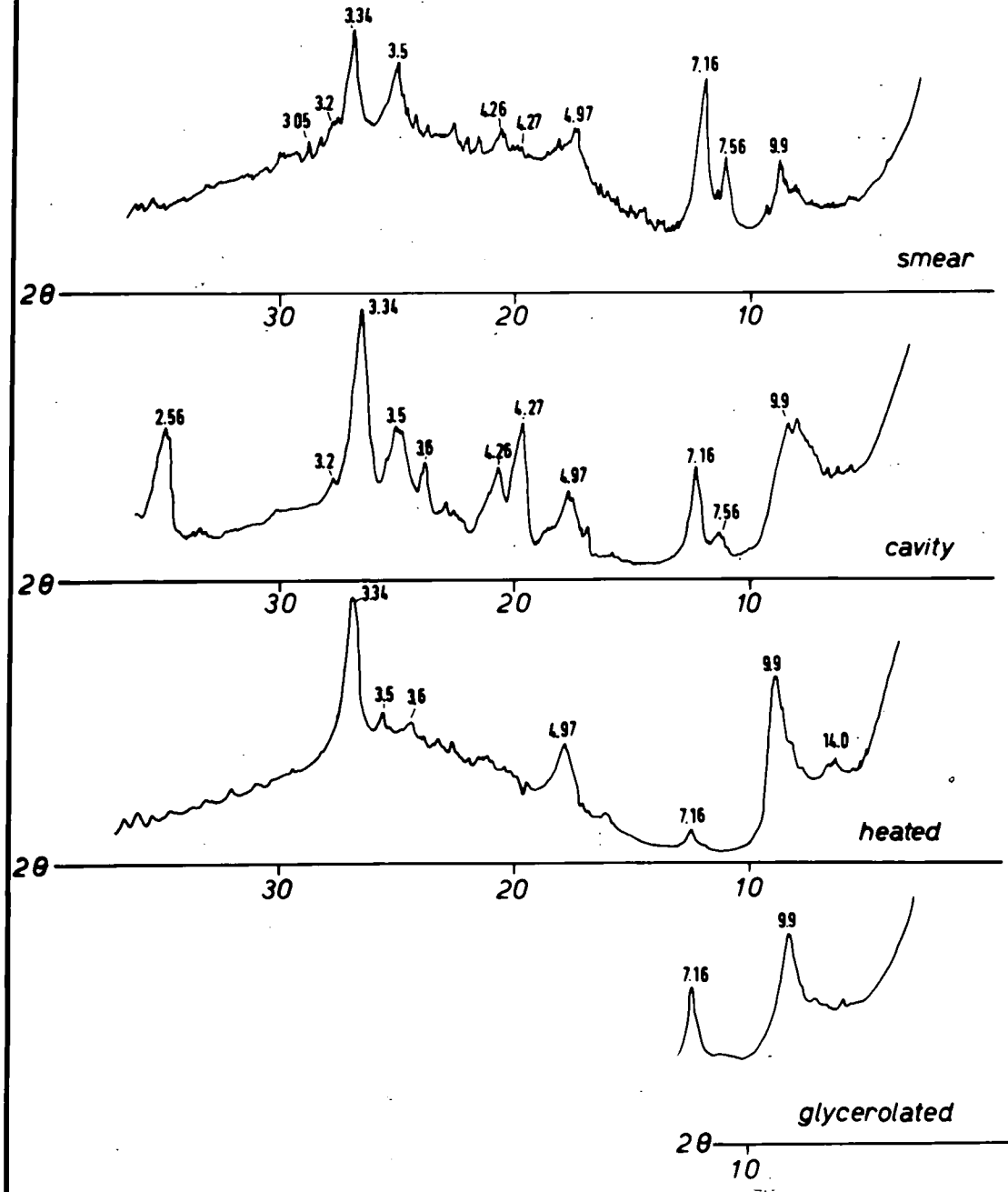
This sample was taken from the Mohope Burn (761490), a tributary of the West Allen. A stone count indicated that this sample was a local till with a very high percentage of shale (c.52 per cent).

The presence of illite in this sample is indicated by a series of reflections at 9.9, 4.97, 4.47 and 2.56A. An illite/mixed-layer component is indicated by the broad peak on the cavity trace (Fig. 10.2) which sharpens on heating to 550°C.

Two peaks, which are considerably reduced on heating, at 7.16 and 3.5A indicate the presence of a kandite (kaolin). The chlorite peak is only readily apparent in the heated sample and here it is a broad diffuse peak,

Fig. 10.2

X-RAY DIFFRACTION CURVES FOR SAMPLE 2.



indicating a poorly crystalline chlorite. Glycerolation had no effect on any of the peaks and it is concluded that swelling clay minerals are absent or present in very small quantities. A small peak at 3.03A is attributable to calcite. A peak at 3.2A, on the shoulder of an intense quartz peak, probably represents a felspar mineral.

The intense peak at 3.34A and the weaker peak at 4.27A are indicative of quartz. Three peaks at 7.56, 4.27 and 3.059A are characteristic of gypsum. Brown (1961) stated that gypsum decomposes on heating to anhydrite. This decomposition is seen in Figure 10.2, where, in the heated sample the gypsum peaks are no longer in evidence.

### Sample 3. (Fig. 10.3).

Sample 3 was obtained from Peasmeadows (852471) and is representative of those tills which are dominated by sandstone and having smaller percentages of shale as determined in a stone count.

Peaks at 9.98, 4.47 and 2.56A are indicative of illite. The broad nature of the 9.98A peak in the cavity preparation indicates the presence of illite/mixed-layer minerals. Confirmation of this is seen in the trace of the heated sample. Here, the illite peak sharpens as the mixed layer element loses some of the water contained in its lattice.

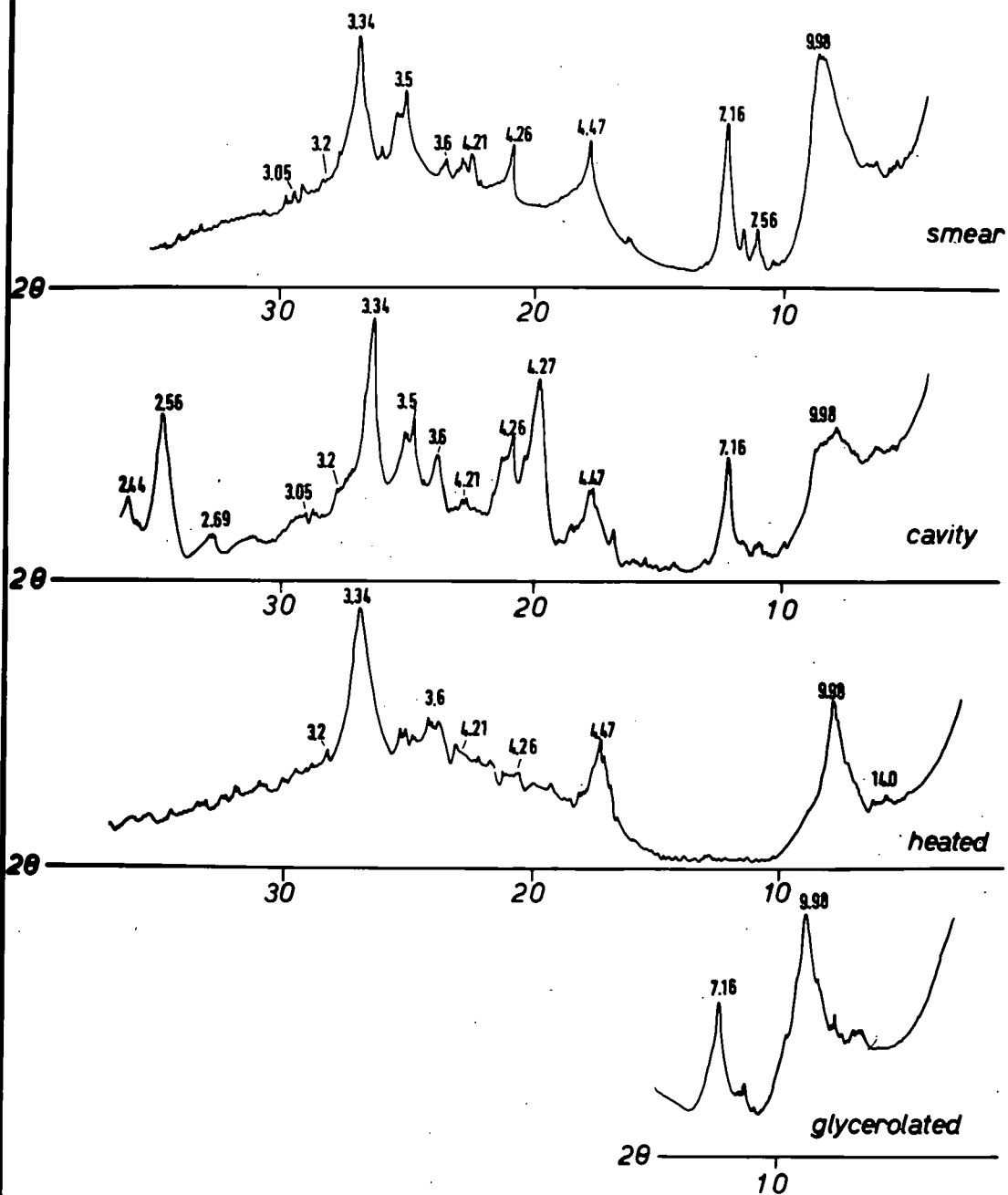
Kandite peaks at 7.16A and 3.5A are present in this sample. The peaks disappear entirely on heating to 550°C thus confirming the identification.

All four preparations indicated only small amounts of chlorite; no well marked peak other than in the heated sample is to be observed. The intensity of the 14A peak often increases on heating and when only very small quantities of crystalline chlorite are present such treatment allows positive identification. No expanding clay minerals were found in this sample. As expected quartz was present, its two peaks occurring at 3.34A and 4.26A.

A strong peak at 7.56A and two peaks at 4.27A and 3.059A indicate the presence of gypsum; all three peaks collapsed on heating the sample to 550°C. A peak at 3.6A and weak peaks on the shoulder of an intense quartz

Fig. 10.3

### X-RAY DIFFRACTION CURVES FOR SAMPLE 3



peak at c.3.2A indicate the presence of a feldspar mineral. An iron oxide, goethite, is clearly indicated by three peaks at 4.21, 2.69 and 2.44A in the cavity preparation (Fig. 10.3).

Sample 4. (Fig. 10.4)

This sample is the first of two samples which have a distinct reddish colouration in the field. It was taken from a section at Byers Hall (652598).

Peaks at 9.98, 4.97, 4.47 and 2.56A indicate the presence of illite. The asymmetry of the illite peak at 9.98A indicates the presence of some illite/mixed-layer minerals.

A number of small peaks in the smear and cavity preparations occur above 17A; on heating the samples the peaks disappear indicating that they are basal reflections from mixed-layer mineral species. Glycerol treatments failed to produce any new peaks and smectites are probably absent.

Clear peaks at 7.16A and 3.5A indicate the presence of kandite (kaolin); these peaks collapsed on heat treatment.

A very well defined peak at 14A, which is not affected by heating indicates the presence of well crystallised chlorite.

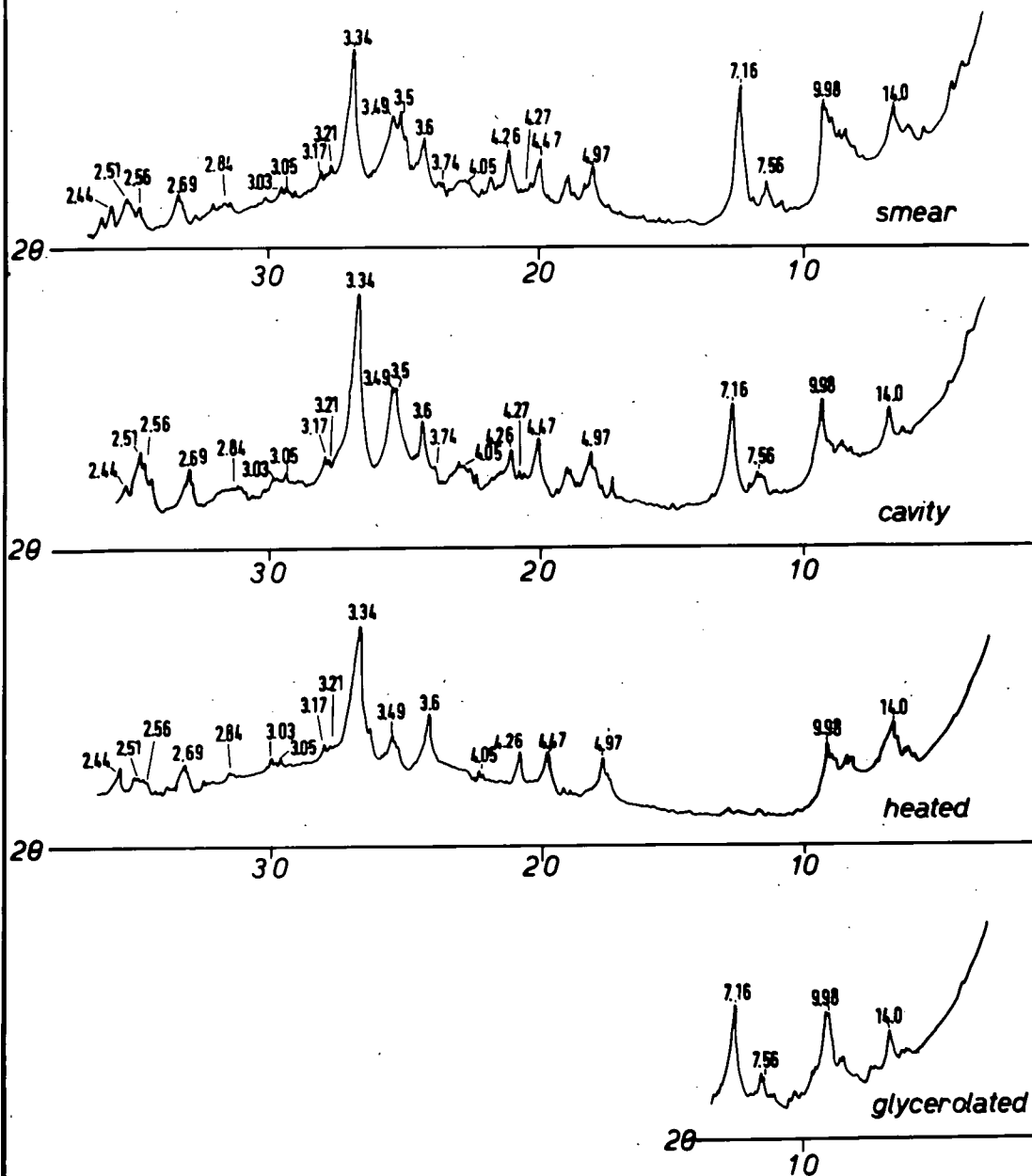
Some calcite is also present in this sample and is identified by a peak at 3.03A. Two peaks at 3.34A and 4.26A indicate the mineral quartz, a seemingly ubiquitous mineral.

A strong peak at c.3.6A, and weaker peaks at 3.74 and 4.05A are indicative of plagioclase feldspar, while peaks at 3.21A and 3.17A indicate the presence of an alkali feldspar.

Reflections at 2.69A and 2.51A are characteristic of hematite. As mentioned earlier, a 2.69A peak is also indicative of goethite and the problem arises as to whether goethite is also present in this sample. Goethite is recognised by three peaks at 4.21, 2.69 and 2.44A. When quartz is present in the sample, even in minute amounts it will mask the 4.21A peak. A peak at 2.69A could indicate the presence of either hematite or goethite. The last possibility of differentiating between hematite and goethite depends on the reaction of the 2.44A peak to heat treatment. A peak at 2.44A is

Fig. 10.4

### X-RAY DIFFRACTION CURVES FOR SAMPLE 4



also characteristic of a weak higher order reflection of illite which remains unchanged on heating to 550°C. If the 2.44A peak disappears on heating the slide to 550°C it may be concluded that this peak probably represents goethite rather than illite. In this sample the 2.44A peak remained after heat treatment and it is concluded that goethite was not present and that the 2.69A peak must therefore be a hematite reflection.

A broad peak at 7.56A and smaller peaks at 4.27 and 3.059A suggest the presence of gypsum. Two peaks at 3.49A and 2.84A suggest an anhydrite mineral in the clay fraction of this sample.

Sample 5. (Fig. 10.5).

Sample 5 was taken from an exposure near Softley, in the South Tyne valley (675555). In the field the till had a distinct red colouration and a stone count indicated that about 65 per cent of the gravel fraction was erratic.

A series of peaks at 9.98, 4.97, 4.47 and 4.11A indicate the presence of a mica clay mineral (illite). The asymmetry with the tail to the higher Angstrom values indicates that illite/mixed-layer minerals are also present. This identification is confirmed in the heated sample by the sharpening of the 9.98 peak and its loss of asymmetry.

Glycerolation produced no new peaks at c.17A and smectites are probably absent from this sample. The sharpening of the 9.98A illite peak on glycerolation indicates the presence of illite and either vermiculite or smectite mixed-layer minerals (Gjems 1967).

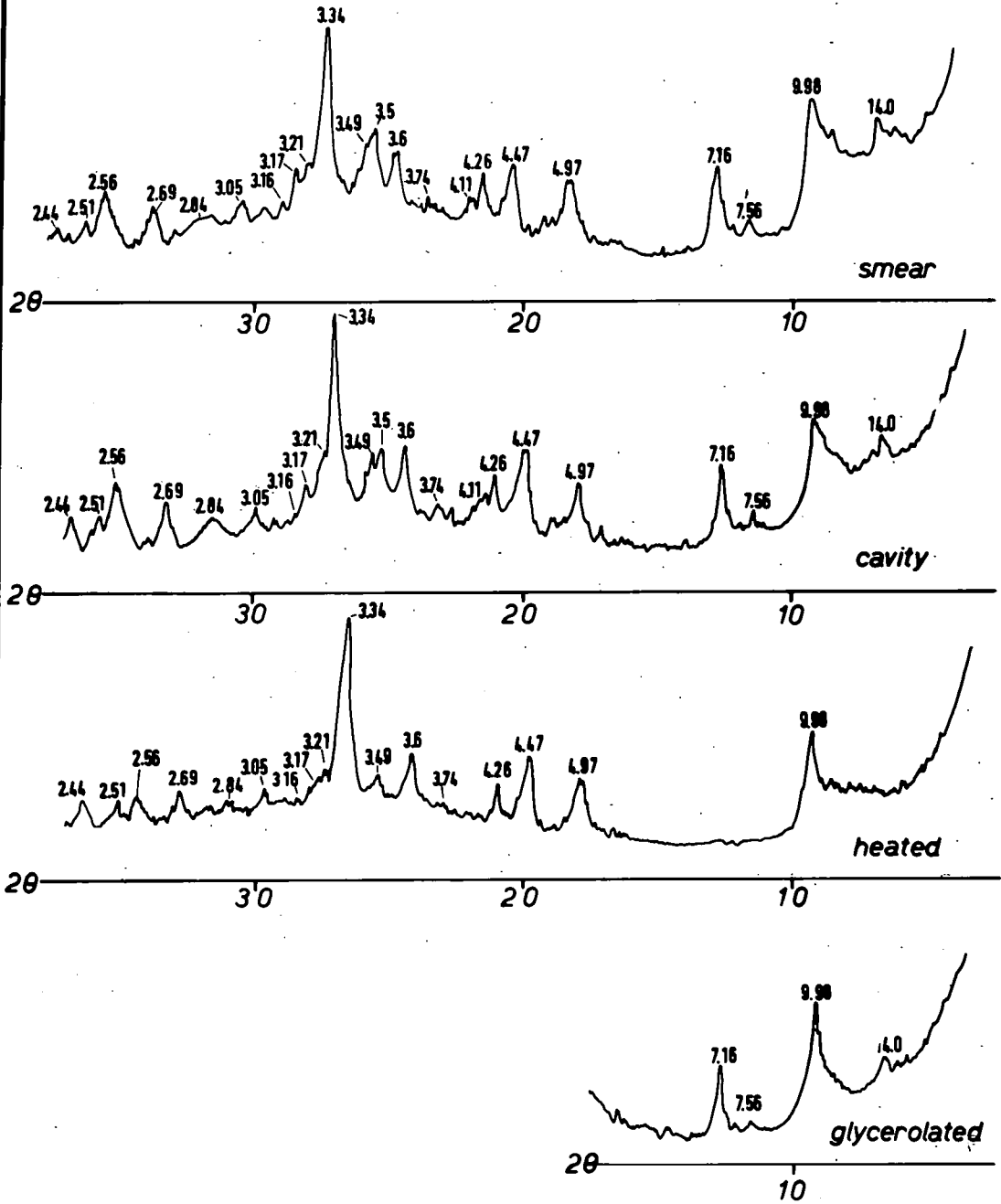
Two peaks at 7.16A and 3.5A indicate that a kandite is to be found in this sample. The identification is confirmed by heating the sample to 550°C (Fig. 10.5). The 7.16A peak collapses entirely while a small peak still remains at 3.5A, representing the overlapping peak of another clay mineral.

A well defined peak at 14A, which was not affected by glycerolation is characteristic of chlorite. It is of interest to note that in the heated sample (Fig. 10.5) the 14A peak collapses; this is probably due to the chlorite being poorly crystalline as a result of some decomposition (Grim and Johns 1954). The fact that poorly crystalline chlorite should produce



Fig. 10.5

### X-RAY DIFFRACTION CURVES FOR SAMPLE 5



such well defined peaks presumably means that chlorite is present in considerable quantities in this sample.

A strong peak at 3.34A and a weaker peak at 4.26A indicates the presence of quartz. Both plagioclase and alkali feldspars are found in this sample; peaks at 3.21 and 3.178A are indicative of the alkali feldspars, while peaks at 3.16, 3.6 and 3.74A and a more diffuse reflection at c.3.22A are characteristic of plagioclase feldspars.

Gypsum and anhydrite are indicated in this sample by peaks at 7.56, 3.059, 3.49, 2.84 and 2.32A respectively.

The problem of the differentiation of hematite and goethite, as mentioned in a description of hematite and goethite, as mentioned in a description of sample 4, is also present here. For similar reasons it is concluded that peaks at 2.69 and 2.514A represent hematite.

#### Conclusions.

Five representative samples of the clay fraction of glacial till have been analysed, and it is possible to come to a number of interesting conclusions.

All five samples contained quartz, a mica clay mineral (illite) and a kandite (kaolin). The combined intensity of their peaks suggest that these three minerals probably represent the bulk of the clay mineral in the samples.

The three local tills, samples, 1, 2 and 3, all have identifiable calcite peaks, the calcite probably being derived from limestone. It is of interest to note that the limestone till (sample 1) has a very pronounced calcite peak, suggesting that calcite is present in some quantity. Two samples of local till (samples 1 and 3) had an iron oxide, goethite, present. The dominant detectable iron oxide in the two samples of red tills, samples 4 and 5, was hematite. It has already been shown that in terms of total ferric oxide content it is not possible to distinguish the erratic-containing tills from the local tills, although the writer initially thought that the reddish tills derived from the Lake District and Southern Scotland might contain greater amounts of ferric oxide. The X-ray mineralogy as described

here suggest that the difference in colour between the local and foreign tills is due to a difference in iron oxide species rather than to differences in quantity, with the reddish tills containing hematite and the local drab tills goethite.

The two samples of reddish till, samples 4 and 5, also had clearly indicated peaks for chlorite at 14A, which were for the most part weak or absent in the three samples of local till. This finding is in full agreement with the stone counts. The chlorite detected in the reddish tills could have come from the New Red Sandstone where it has been recorded by Thomas (1909) or from igneous and metamorphic rocks where it occurs both as an original constituent and also as an alteration product (Milner 1940).

This qualitative survey would seem to indicate that some discernable differences are evident in the clay mineralogy of the five representative samples of glacial tills studied. There appears to be a general indication of provenance from these studies and further quantitative studies would doubtless be of great interest.

#### Section B. Heavy Mineral Analyses.

The analysis of heavy minerals as described in this section is to be regarded as a complementary study to analyses of clay mineralogy and coarse sand and gravelstone counts described in previous sections of this thesis.

Unlike some of the other techniques described in this thesis the use of heavy mineral analyses in the study of glacial deposits has become a common method of approach to many problems.

Heavy minerals have been used extensively in the study of weathering in till profiles (Allen 1930; Gravenor 1954; Brophy 1959; Frey, Willman and Glass 1960). Particularly in North America, and to a lesser extent in Great Britain, heavy mineral analysis has been used to study provenance. As a technique in glacial studies it was probably first used by Boswell (1916) in a petrological study of the North Sea Drift. Although Boswell (1916, 1928) Raistrick (1929) and Griffiths (1939) used the method with interesting results the technique has never been particularly popular amongst British geomorphologists. One of the most recent studies was that by Catt (1963) who studied

the heavy mineral assemblages in the tills of Holderness.

A great deal of work has been done in North America on heavy mineral analyses of glacial deposits, indeed the method, although time consuming, has become almost a standard procedure. Several European workers have also used the method with success. Some of the more important papers published on this subject by North American and European workers are: Derry 1933; Kruger 1937; Krynine 1937; Gravenor 1951; Jarnefors 1952; Dreimanis and Reavely 1953; Dreimanis et al 1957; Kaiser 1962; and Bik 1966.

Heavy minerals have been used in a particularly novel way to study the structure of glacially contorted ridges by De Jong (1953).

#### Methods of Analysis.

Five grams of the material which passed the no.72 B.S. sieve during the dry-sieving stage of sample preparation (Appendix 2) formed an initial sample for heavy mineral analysis. The size range of particles within such a sample was from 0.2 mm. to 0.062 mm. The sample was then cleaned in 1 N HCl, washed and gently dried. Separation of the heavy minerals from the light fraction was accomplished using a heavy liquid, Bromoform, which has a specific gravity of 2.89. The residue of heavy minerals was washed free of Bromoform using methylated spirits and mounted in Canada Balsam on a glass slide ready for examination. A standard binocular petrological microscope was used for the identification of the non-opaque minerals. The colour, crystal habit, refractive index extinction angle and optic sign were determined using a combination of orthoscopic and rotating conoscopic light. In the case of the opaque minerals identification was made easier using a reflected light source. At least 300 grains, counted in transects across the heavy mineral mounts were recognised in each sample. 52 till samples were analysed using the methods described above.

Before describing the results of the 52 analyses each of the mineral species found in the heavy residue will be described briefly.

#### Sphene.

Very few grains of sphene were noted in the analyses. Of those grains seen the majority were of the euhedral diamond-shaped habit. Most grains were brownish to brownish-yellow in colour and failed to extinguish completely under cross nichols.

### Epidote.

A vitreous lustre together with a green to greenish-yellow colour was typical of the epidote grains identified. Many grains were subangular and appeared like small chips of broken glass.

### Amphibole/Pyroxene.

No attempt was made to distinguish these two groups of minerals as the total percentage of both groups was very small. Ragged cleavage flakes, with a variable pleochroism in green brown-green and rarely blue-green were typical of hornblend, the most common amphibole present. Enstatite prisms with a grey, dirty appearance were the most common pyroxene present although there were one or two grains of pleochroic hypersthene.

### Tourmaline.

Most tourmaline grains were well rounded and nearly oval. The typical green-brown colour of these grains, together with a marked pleochroism made their identification very easy.

### Sillimanite.

Sillimanite grains were often irregular, colourless, needles with marked parallel striae. Its straight extinction distinguished sillimanite from kyanite, with which it may be confused.

### Hematite/Limonite.

Hematite and limonite were identified using reflected light. Some difficulty was encountered in trying to identify these grains separately as limonite gradually oxidises to hematite; all stages of this change were seen in the counts.

### Magnetite/Ilmenite.

Both of these minerals have a black or bluish-black metallic lustre in reflected light and without chemical tests it is optically very difficult to distinguish between them. For this reason magnetite and ilmenite were not distinguished in the mineral counts.

### Monazite.

A few light yellow, egg-shaped grains of monazite were observed. The relief was, in all cases, much higher than Canada Balsam. Good positive biaxial interference figures were seen.

### Garnet.

Garnet was found in the great majority of the samples analysed. Both red and colourless garnets were easily recognised by their high relief, isotropism and conchoidal fracture.

### Biotite.

Flakes of biotite were present in about one fifth of the 52 samples. Most grains were brown in colour and produced a good negative pseudo-uniaxial interference figure. The edges of some grains were somewhat bleached in appearance where the biotite was altering to chlorite.

### Rutile.

Rutile is a nearly ubiquitous mineral species in the samples analysed. Most specimens encountered were well formed and either amber coloured or a foxy red, and many were characterised by striations parallel to the long axis of the mineral.

### Zircon.

Zircons in the samples analysed were prismatic with pyramidal, but somewhat rounded terminations. The majority of the identified grains were colourless and inclusions were very abundant.

### Staurolite.

Rather irregular hackly grains of staurolite with a yellow or golden colouration were fairly common. All showed a marked pleochroism which served as a useful feature in their identification.

### Kyanite.

Long angular flakes of kyanite were observed in one or two samples. A well marked cleavage was observed in most grains. Nearly all the grains examined were colourless although a few were pale blue. Nearly all the grains yielded a biaxial interference figure.

## Results of the mineral counts.

Before describing the results it should be noted that it was not expected to find many qualitative differences in the mineral species as between the local tills and those with erratic-containing material. A great many of the mineral types described in this analysis are also to be found in the sedimentary strata of the Alston Block.

It can be seen in Figure 10.6 that a considerable range in the percentage of opaque minerals is present in the samples analysed. Sample no. 46 (Table 10.1) is rather anomalous in having only 30.5 per cent opaque material; as seen in Table 10.1 this sample is dominated by zircon.

As a generalisation it would appear that, for the most part, the local tills (regarded as those without erratic material in the stone count) have slightly higher percentages of opaque minerals in the heavy mineral residue than do the erratic-containing tills. Those samples which contain very high percentages of erratic material in the stone count (sample nos. 9, 32, 49 and 50, Tables 10.1 and 7.1) are also those which contain the lowest percentages of opaque material. Furthermore it may be seen in Table 10.1 that those samples with low hematite-limonite/magnetite-ilmenite ratios are also those with high percentages of erratic material in the stone counts (Table 7.1).

The highest percentage of pyrite recorded in the 52 heavy mineral counts was 22.6 per cent in sample no. 44 (Table 10.1). Examination of the stone count for this sample (Table 7.1, no. 44) indicated that this till has a very high percentage of shale and it is very probable that the pyrite is derived from the breakdown of the shale as the till was formed. Similarly the 18.9 per cent of pyrite in the heavy residue of sample no. 3 (Table 10.1) is also associated with a high percentage of shale in the stone count (Table 7.1, no. 3).

Similar quantitative associations between the heavy mineral counts and the stone counts are indicated in the tourmaline percentages. Tourmaline was found to be present in all the samples analysed. This was not unexpected as tourmaline occurs in the sedimentary strata of the Alston Block (Gilligan 1919; Butterfield 1940). In samples 9, 32, 49 and 50 (four samples rich

Table 10.1. Heavy Mineral Analyses.

Sample * (results in %)	1	2	3	4	5	6	7	8	9	10
<u>Mineral</u>										
Sphene	0.6							0.9		0.2
Monazite	0.3			0.3						
Garnet	0.3	0.3		0.9	0.3	1.2	0.5		0.3	1.7
Biotite	1.6						0.2			0.2
Rutile	0.6	0.6	0.6	1.2			0.5	0.9	0.3	0.8
Zircon	7.4	2.7	1.6	5.9	3.4	2.1	3.7	2.6	9.2	1.7
Kyanite				0.3						
Staurolite	0.6			0.6	0.3		0.2	0.3		0.5
Epidote		0.3				0.3		0.3	0.3	0.5
Amphibole/Pyroxene			0.3	0.9		0.3				
Tourmaline	0.9	0.3	0.3	0.3	0.9	0.9	2.0	0.9	2.1	0.5
Sillimanite			0.3		0.6			0.3		
Hematite/Limonite	70.8	82.9	58.0	70.7	91.5	58.4	79.4	65.0	67.9	73.9
Magnetite/Ilmenite	9.7	9.6	19.8	14.6	1.8	27.8	5.0	16.8	12.9	13.1
Pyrites	6.7	2.7	18.9	4.0	0.9	8.8	7.4	11.5	0.6	5.9
Unidentified	0.5	0.6	0.2	0.3	0.3	0.2	1.1	0.5	0.3	1.0
Total Number of grains counted	309	322	312	321	320	327	350	303	324	334

\* Sample locations are indicated in Fig. 7.1.



Cont. Table 10.1. Heavy Mineral Analyses.

Sample * (results in %)	11	12	13	14	15	16	17	18	19	20
<u>Minerals</u>										
Sphene						0.3				
Monazite								0.2		
Garnet	0.3	0.9		0.3	1.5	0.9	0.3	1.1		0.3
Biotite					1.5					
Rutile	0.3		0.6		0.3	0.3	0.3	0.8	0.6	
Zircon	6.9	10.3	5.8	1.5	1.5	5.2	2.1	1.7	3.1	5.7
Kyanite										
Staurolite	0.6	0.3	0.3	0.3				0.5	0.3	0.3
Epidote				0.3	0.6					
Amphibole/Pyroxene	0.3	0.9				0.6				1.2
Tourmaline	0.9	0.3	0.9	0.6	1.2	0.9	1.2	1.7	0.3	1.2
Sillimanite	0.3				0.3					
Hematite/limonite	70.2	66.9	75.4	71.2	65.8	82.6	85.1	57.3	85.9	81.4
Magnetite/ilmenite	5.6	9.3	7.1	15.0	19.3	5.9	7.2	34.3	6.6	6.0
Pyrites	14.2	10.6	9.4	10.6	7.6	2.9	3.6	2.0	2.8	3.5
Unidentified	0.4	0.5	0.5	0.2	0.5	0.4	0.2	0.4	0.4	0.4
Total Number of grains counted	316	309	306	320	325	305	331	349	314	313

\* Sample locations are indicated in Fig. 7.1.

Cont. 10.1. Heavy Mineral Analyses.

Sample * (results in %).	21	22	23	24	25	26	27	28	29	30
<u>Mineral</u>										
Sphene										
Monazite										
Garnet		0.6	1.2		0.3			0.3		
Biotite	0.2		0.3		1.5	0.6		0.6		0.3
Rutile	1.1	0.9	0.9		0.3	0.3		0.3	1.0	0.3
Zircon	9.6	7.3	1.6	2.3	2.5	3.2	7.2	5.3	6.6	2.9
Kyanite										
Staurolite	0.5	0.3						0.3		
Epidote					0.3	0.3	0.3		0.6	
Amphibole/Pyroxene	0.2		0.9			1.6				0.3
Tourmaline	1.9	1.5	2.5	1.3	0.3	0.9	0.9	2.6	0.6	0.6
Sillimanite	0.2					0.3				
Hematite/Limonite	71.6	64.9	78.3	92.4	73.6	72.9	72.1	57.6	81.0	78.5
Magnetite/Ilmenite	7.7	11.8	7.4	0.6	8.5	5.4	13.1	25.6	7.0	12.3
Pyrites	6.6	12.5	6.4	3.2	12.6	14.1	6.2	7.0	3.0	4.2
Unidentified	0.4	0.2	0.5	0.2	0.4	0.4	0.2	0.4	0.2	0.6
Total number of grains counted	363	328	310	304	315	311	319	300	300	308

\* Sample locations are indicated in Fig. 7.1.

Cont. Table 10.1. Heavy Mineral Analyses.

Mineral	31	32	33	34	35	36	37	38	39	40
Sphene		0.3								
Monazite										
Garnet	0.9	1.8		0.3	0.9	0.6	0.6	0.6	0.3	
Biotite		0.6	0.3		0.3					3.5
Rutile	0.3	0.3	0.3	0.6	0.3	0.3	2.0	0.6		0.6
Zircon	2.9	8.7	4.5	2.9	9.9	5.0	4.0	6.8	3.5	7.0
Kyanite							1.0			
Staurolite	0.3	0.6			0.3					0.3
Epidote										
Amphibole/Pyroxene		1.8					1.0	0.3	0.6	0.6
Tourmaline	0.3	3.9	0.9	0.3	2.7	1.6	0.6	0.6	0.9	0.9
Sillimanite		0.3						0.6		
Hematite/Limonite	81.0	48.0	89.6	91.0	65.6	80.0	61.6	49.8	8.38	70.3
Magnetite/Ilmenite	7.9	31.7	3.2	3.3	3.4	6.5	21.6	21.8	4.8	10.5
Pyrites	5.9	1.8	0.9	1.3	16.4	6.0	7.3	18.6	5.8	6.0
Unidentified	0.6	0.2	0.3	0.4	0.2		0.3	0.3	0.3	0.3
Total number of grains counted	301	331	310	302	323	300	300	321	310	314

\* Sample locations are indicated in Fig. 7.1.

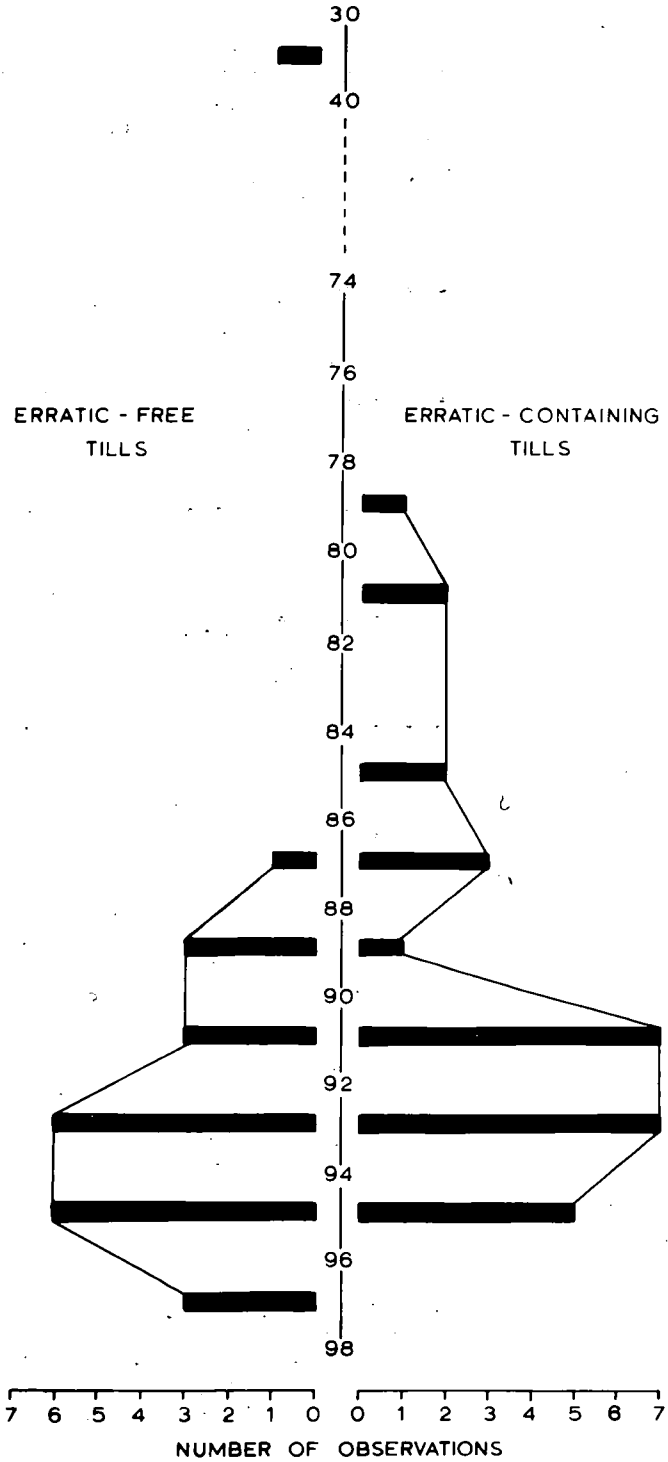
Cont. Table 10.1. Heavy Mineral Analyses.

Sample * (results in %)	41	42	43	44	45	46	47	48	49	50	51	52
<u>Mineral</u>												
Sphene						1.0	3.4	1.0	2.9	0.3		
Monazite					1.2	5.6			4.2	1.2	0.3	0.9
Garnet	0.6	1.9	0.9	0.3		1.0				0.3		
Biotite					0.6	1.0			0.6	0.9	0.6	1.2
Rutile	0.3	0.3	0.6		3.2	2.0		0.3	0.6	0.9	0.6	3.8
Zircon	5.5	5.0	2.6	2.5		52.6	5.7	5.0	2.9	11.6	1.2	0.3
Kyanite												
Staurolite		0.3	0.3	0.3	0.3	1.6	0.5	0.3		1.2		
Epidote		0.6	0.3	0.9	0.6	0.6	0.2	0.3	1.9	2.5	1.9	1.9
Amphibole/Pyroxene						0.6		0.6	1.9	0.3	0.6	0.6
Tourmaline				1.2	0.9	3.6	0.2	0.6	5.8	6.1	0.6	1.2
Sillimanite								0.3				
Hematite/Limonite	74.6	76.3	72.5	38.3	80.1	7.6	81.7	69.6	40.1	31.0	74.7	63.5
Magnetite/Ilmenite	13.1	12.1	20.2	33.4	11.2	22.6	7.5	16.3	36.2	41.7	14.2	20.6
Pyrites	4.3	2.6	1.6	22.7	1.9	0.6	0.2	5.3	2.9	2.5	6.1	5.1
Unidentified	0.8		0.4	0.4		0.6	0.6	0.4	0.6	0.4	0.4	0.9
Total number of grains counted	308	305	306	308	312	300	345	300	306	309	309	310

\* Sample locations are indicated in Fig. 7.1.

Fig. 10.6

PERCENTAGE OF OPAQUE HEAVY MINERALS



in erratic material (chapter 7, Table 7.1), the tourmaline content in the heavy residue was well above average, indeed in sample no. 50 the tourmaline content was some 6.1 per cent of the 309 grains counted. It is not coincidence that this sample contained some 84 per cent erratic material in the stone count (sample no. 50, Table 7.1). It is therefore evident that some enrichment of tourmaline in the heavy residue of the tills analysed must be due to the breakdown of erratic material.

Twenty two samples contained amphibole-pyroxene minerals (Table 10.1). Some difficulty was encountered in relying on these mineral types as provenance indicators. Although little work has been done on the petrology of the consolidated sediments of the Alston Block it would seem that amphiboles and pyroxenes are not present in the Carboniferous strata. However, these mineral species are found in the whin sill, a quartz dolerite, which has restricted outcrops within the region. It does not seem possible, therefore, to rely on the presence of an amphibole or a pyroxene as an indication of provenance.

Small amounts of epidote were picked up in about half of the samples investigated. The largest percentage, 2.5, occurred in sample no.50 (Table 10.1) which also contained a large proportion of erratic material. Almost certainly some of the epidote encountered was derived from metamorphic erratics but as epidote also occurs in the Yoredale sandstones (Butterfield 1940) its use as a provenance indicator is limited.

Only three of the samples investigated contained any kyanite (samples nos. 4, 37 and 52, Table 10.1). No kyanite has been recorded from Carboniferous strata in the Alston Block and the presence of this mineral species probably indicates a westerly component in the provenance of the till. The presence of kyanite in samples no. 37 and 52 could be expected as the provenance of these two samples was already known to have a westerly component from stone count evidence. It was of interest to note the presence of kyanite in an essentially local till at 713469 (sample no. 4, Table 10.1). The till at this locality, just north-west of Alston, was formed by a local valley glacier which most effectively removed till of a westerly provenance from the bottom of the South Tyne Valley. Although the stone count did not reveal any erratic material (see Table 7.1, no.4) it was not too surprising,

in view of the glacial history of the South Tyne valley, to find some vestage of the incursion of westerly ice.

All of the remaining minerals, staurolite, zircon, rutile, biotite, garnet, monazite and sphene, are known to occur on the Carboniferous sediments of the Alston Block (Gilligan 1919; Butterfield 1940 and Burgess and Harrison 1967); their use therefore, as provenance indicators is obviously limited.

Although this study has been of limited use in the study of glacial provenance more meaningful pictures will emerge when the somewhat scant literature on the petrology of the sediments of the Alston Block is enlarged.

**SECTION 4.**

**SYNTHESIS.**



## Chapter 11.

### Factor Analysis.

#### Introduction.

Geomorphologists, in company with other scientists, often need to classify observations and facts. Such classifications although arbitrary and utilitarian, may be of great value in enabling the underlying natural relationships to be perceived. One method of obtaining an objective classification is factor analysis.

The origins of factor analysis go back to the early years of the present century when Charles Spearman (1904) and a school of investigators developed its essential concepts as a tool in psychometric research. Thurstone and a group of American workers added significantly to the theory and practice of factor analysis, notably by increasing its generality (Thurston 1931), by improvements and refinements in its exposition (Thurston 1947; Holzinger and Harman 1941), and by developing practical computing techniques (Harman 1967).

This chapter is conveniently divided into two sections:

1. A brief description of factor analysis;
2. Results of a Q-mode analysis on the tills of the Alston Block.

#### 1. A brief description of factor analysis.

Before discussing the statistical rationale behind factor analysis it is pertinent to ask the question, 'why use factor analysis at all?' Cole and Smith (1967) succinctly answered the question in a factor analytical study of 25 variables measured for each of the 52 states of the U.S.A. They suggested that it was possible to map each of the 25 variables separately on transparent paper such that each mapped variable could be looked at individually and also be compared two at a time, three at a time and so on, as desired. Distributions that showed similar trends over the surface of the maps would be seen to correlate. Cole and Smith 1967

advance several reasons why such visual exercises run into difficulties. Firstly, to view all possible combinations of the 25 maps, it would be necessary to consider about 100,000,000 combinations. Allowing 10 seconds to consider each combination this would take a person about 200 years. Secondly, any combination of more than three or four variables viewed together becomes very complex to handle visually. Thirdly, there seems to be no assurance that the individual viewers will not see correlations they expect to see rather than correlations that exist. Factor analysis does the work of combining the 25 maps and attempts to identify the characteristics which variables have in common and which result in their intercorrelation.

Factor analysis is, therefore, a reasonably objective method of grouping and simplifying the number of intercorrelated variables thus allowing a meaningful classification to be made.

a. The correlation matrix.

Factor analysis may be carried out in two distinct but related procedures. In R-mode factor analysis attention is focussed on  $n$  variables and the results follow from an inspection of an  $n \times n$  matrix of relationships (usually taken as product moment correlations) between all pairs of variables. In Q-mode analysis attention is focussed on  $N$  samples, and results follow from an inspection of an  $N \times N$  matrix of relationships between all pairs of samples.

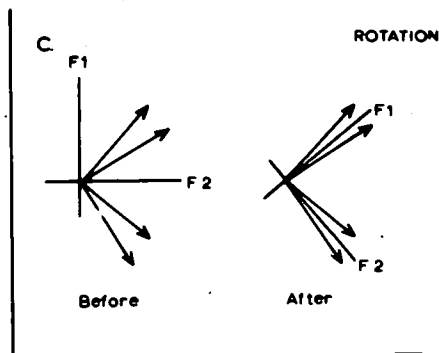
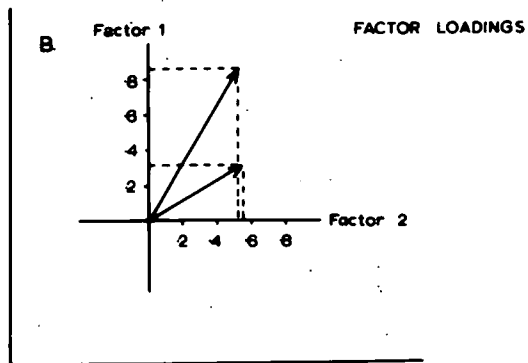
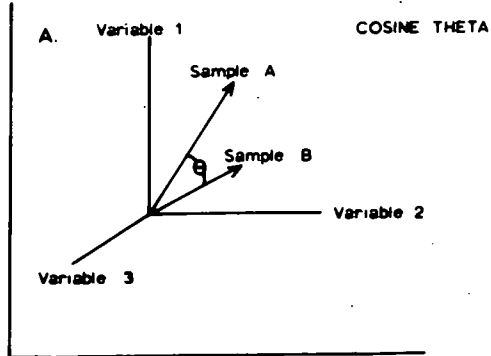
In Q-mode analysis cosine-theta coefficients are used to represent correlations in the matrix. This can be considered graphically in the simple case (Fig. 11.1a) by considering the correlation of two samples (A and B) represented as vectors in a coordinate system of three variables. The angle  $\theta$  is a measure of the similarity between the two vectors. The smaller the angle  $\theta$  the greater the similarity between the two vectors. Algebraically this concept may be expanded into  $n$  dimensional space, where  $n$  represents the number of variables.

b. Factor Axes.

Very probably, many sample vectors may lie relatively close together in the  $n$  dimensional space. In order to simplify this complex  $n$  dimensional structure, factor axes are constructed which project

Fig. 11.1

### SOME PROCEDURES IN FACTOR ANALYSIS (see text).



mathematically, into this coordinate system.

c. Factor loadings.

Factor loadings are best explained by simple illustration (Fig. 11.1b). Lines drawn perpendicularly from the sample vectors onto factor axes of unit length are called factor loadings. The relationship between factor axes and factor loadings is easily demonstrated (Fig. 11.1b). Vectors with higher factor loadings lie closer to a factor axis than do vectors with lower loadings. Using this information it is possible to deduce which samples lie near to each factor axis.

There are various methods of fitting factor axes to similarity coefficient matrices (Harman 1967). Commonly the factor axes are fitted by the principal components method, in which the first axis is positioned so that the sum of the squares of factor loadings is minimised. Geometrically this may be viewed as placing the first factor axis in the centre of gravity of the vector system (Harbaugh and Merriam 1967, p.184). The next factor axis which is orthogonal to the first is positioned so that the sum of squares of the factor loadings on it is also maximised. Subsequent axes are positioned in a similar manner.

d. Rotation of factor axes.

In order to simplify interpretations of the factor loadings it is common practice to rotate the factor axes after they have been established. The purpose of rotating factor axes is to position them such that they lie close to any distinct clusters that may exist in the similarity coefficient matrix (Fig. 11.1c). A simple way of showing the associations of the samples is to plot the factor loadings graphically, the ordinate and abscissa representing the factors.

e. Factor Weightings.

Once the factor axes and loadings have been computed it is then required to know which particular variable, or groups of variables, is substantially represented by each factor. In Q-mode analysis this may be done by an inspection of the factor weightings. The weightings indicate

how the  $N$  samples, which are distributed in space about the factor axes, vary with respect to the  $n$  variables. Thus high factor weightings on a variable indicate that a factor is highly associated with that variable, and vice versa.

## 2. Results of Q-mode analysis on the tills of the Alston Block.

In as much as the Q-mode analysis emphasizes relationships among samples, it provides an important method for classifying sedimentological data. Factor analysis in the Q-mode is a rapidly expanding technique in a variety of geological fields, particularly sedimentology (Imbrie and Purdy 1962; Imbrie and Van Andel 1964).

The raw data for this analysis has already been described in preceding chapters. As a preliminary stage in the analysis the data were transformed by dividing each value by the highest value observed for that particular constituent. This transformation gives equal weight to each variable; such a transformation is useful because some variables were not measured on a percentage scale, e.g. pH,  $\rho$  mean. No additional transformations are necessary in Q-mode analysis because the correlation matrix is built up from cosine-theta and not product moment correlation coefficients.

The cosine-theta matrix consisted of a 52 x 52 array, thirty variables being measured for each of the 52 till samples under analysis. The number of unique coefficients is derived from the formula  $n^2 - n/2$ ,  $n$  being the number of samples. The total number of unique coefficients is, therefore, 1326 ( $n = 52$ ).

It is at this point that the usefulness of factor analysis is indicated. Obviously it would be difficult, if not impossible, to visually assess such an array of coefficients. Here, the high speed computer is invaluable. The factor analysis described in this chapter was performed on the University of Durham IBM 360/67 using a programme written by Klovan (1968). This programme allows the abstraction of up to ten factors from the cosine-theta matrix.

The first three factors of the varimax rotation accounted for some 81 per cent of the variance of the matrix. For this reason it was decided to limit the analyses of these three factors. The factor axes were constructed

using a varimax rotation procedure (Harman 1967). The factor weightings for the thirty variables used in the analyses are shown in Table 11.1.

Examination of Table 11.1 indicates which of the thirty variables is most closely related to each factor. The variables which appear most closely related are:

Factor I. Hematite/limonite heavy minerals, pH. ferric iron phi sorting, phi mean, per cent clay, silt sand and gravel, per cent shale in stone count.

Factor II. Amphiboles and Pyroxenes in the heavy mineral counts, Tourmaline in the heavy mineral counts, the per cent of erratic material in the stone counts, ilmenite/magnetite heavy minerals, sand and clay.

Factor III. Sandstone in the stone count.

It is important to note here that there is no guarantee that the mathematical factors correspond to the actual environmental factors that may exist in nature. Mathematical factors may strongly reflect the influence of actual factors, but factor analysis, in itself, does not identify the actual factors. Identification is a matter of interpretation (Harbaugh and Merriam 1968).

Once the factors are decided upon it is then possible to examine the factor loadings to see which samples are most strongly associated with each factor. The loadings of each of the first three factors for the 52 samples are shown in Table 11.2.

Interpretation of the factor loadings is facilitated if they are plotted in graph form, with the factors acting as ordinate and abscissa. Ideally, if the analysed samples were divisible into three discrete categories in terms of the 30 measured variables, the factor loadings would cluster into three distinct groups. In Figures 11.2, 11.3 and 11.4 it is seen that three reasonable distinct categories exist.

#### Category 1.

This group of samples loads heavily on factor I and relatively lightly on factor II. It may be observed that this category contains the

Table 11.1

Factor Weightings Q-Mode Analysis.

<u>Variable</u>	<u>Factor I.</u>	<u>Factor II.</u>	<u>Factor III.</u>
Percent sandstone	0.5492	0.2721	5.2935
shale	1.3702	-0.8425	0.8574
erratics	-0.5286	2.2105	-0.0902
limestone	0.1550	-0.3008	-0.1211
coal	-0.0973	0.3409	0.0005
pH	2.0182	0.7365	-0.4004
Coal in matrix	0.5890	-0.2079	-0.2594
Ferric Iron	1.8156	-0.0712	-0.3563
Carbonate	0.7079	-0.1667	-0.1545
Percent gravel	1.1248	-0.2816	-0.2708
sand	1.3174	1.3126	-0.2435
silt	1.4061	-0.2527	-0.3286
clay	1.4312	1.4413	-0.2529
Phi mean	1.5497	1.0249	-0.2741
Phi sorting	1.6264	0.8143	-0.2391
Sphene	-0.1059	0.4154	-0.0452
Monazite	-0.3544	0.8815	0.0245
Garnet	-0.2481	0.8420	-0.1000
Biotite	-0.1326	-0.0103	0.1078
Rutile	0.0396	0.0798	0.1001
Zircon	-0.1859	0.3570	0.0059
Staurolite	-0.3603	0.4701	-0.1073
Kyanite	-0.1409	0.0245	0.2082
Epidote	-0.2826	0.6844	0.2464
Amphibole/Pyroxene	-0.5972	2.5180	0.1248
Tourmaline	-0.5088	2.4934	0.0093
Sillimanite	-0.0950	-0.5185	-0.1400
Hematite/Limonite	2.4437	-0.2375	0.1019
Magnetite/Ilmenite	-0.3962	1.6036	0.1668
Pyrite	0.1406	-0.4776	0.1569

majority of the samples analysed. The samples in this category are associated with high pH's, high ferric iron contents, high shale percentages in the stone counts and with high percentages of hematite and limonite in the heavy mineral fraction. Many of these variables have been shown in previous chapters to be associated with tills of a Pennine provenance rather than with those which have been brought into the area by incursive ice-sheets.

#### Category 2.

This group of samples loads heavily on factor II and relatively lightly on factor I. Factor II is associated with high percentages of erratic material in the stone counts and also high percentages of tourmaline, and amphibole/pyroxene heavy minerals in the sand fraction. This factor, then is an expression of those variables which are particularly characteristic of tills which are not of Pennine provenance and which have maintained much of their original character.

#### Category 3.

This category consists of one sample which loads relatively lightly on both factors I and II.

If the factor loadings for factor I are plotted against those of factor III (Fig. 11.3) three similar categories emerge. The existence of these three groups of samples is further demonstrated when the loadings of Factor II are plotted against Factor III. These two factors together only account for 19.7 per cent of the total variance and are, therefore, rather weak explanations of the total correlation matrix. However, it is seen that three groups of samples are still reasonably distinct (Fig. 11.4) and it may be concluded that a grouping of the till samples into three categories is meaningful.

Broadly speaking the usefulness of such factor analysis studies within the northern Pennines, as demonstrated here, may be seen to be twofold.

#### a. Factor analysis as a tool in till classification.

It has already been mentioned that it is almost as impossible a task to consider visually 30 variables for each of 52 samples and it has been shown how easily factor analysis can cope with such numerical problems.



Table 11.2

Varimax Factor Loadings Q-Mode Analysis.

<u>Sample No. *</u>	<u>Factor I.</u>	<u>Factor II.</u>	<u>Factor III.</u>
1	0.7747	0.2996	0.1146
2	0.9068	0.2659	0.2002
3	0.8027	0.1577	0.0335
4	0.7130	0.2960	0.0090
5	0.8364	0.2133	0.1820
6	0.7990	0.3405	0.2582
7	0.8915	0.3358	0.1687
8	0.8337	0.2561	0.1741
9	0.6006	0.7508	0.0206
10	0.8529	0.2622	0.2752
11	0.8115	0.2891	0.2059
12	0.8471	0.3495	0.1479
13	0.8707	0.3198	0.2016
14	0.8983	0.2641	0.0953
15	0.8141	0.2825	0.1534
16	0.8612	0.3765	0.1313
17	0.9181	0.2274	0.1713
18	0.7250	0.4641	0.2610
19	0.9038	0.2699	0.2247
20	0.7996	0.3890	0.1272
21	0.8442	0.2791	0.1731
22	0.7746	0.3272	0.0873
23	0.8475	0.4099	0.1637
24	0.9160	0.2560	0.0115
25	0.8176	0.3726	0.0778
26	0.7780	0.3916	0.2049
27	0.9145	0.2479	0.1154
28	0.8188	0.3438	0.1251
29	0.9122	0.2649	0.1066
30	0.9201	0.2903	0.1607
31	0.9137	0.2247	0.0930
32	0.5700	0.7158	0.0077
33	0.9275	0.2657	0.1460
34	0.9262	0.2849	0.1429
35	0.8365	0.2766	0.1705
36	0.9079	0.2974	0.1255
37	0.7090	0.2975	0.2550
38	0.7580	0.2690	0.0715
39	0.9205	0.2636	0.0951
40	0.7979	0.3120	0.1534
41	0.8765	0.3396	0.2058

Table 11.2 cont'd.

<u>Sample No.</u> *	<u>Factor I.</u>	<u>Factor II.</u>	<u>Factor III.</u>
42	0.8367	0.2559	0.1447
43	0.8495	0.2620	0.1737
44	0.6528	0.2577	0.0870
45	0.8938	0.3213	0.1428
46	0.4040	0.5060	0.2552
47	0.8454	0.2173	0.0886
48	0.7778	0.3509	0.2755
49	0.4915	0.7646	0.0563
50	0.4373	0.7130	0.0431
51	0.8131	0.2683	0.2431
52	0.6320	0.6063	0.0691
Variance	61.268	12.566	7.181
Cumulative Variance	61.268	73.834	81.015

\* Sample numbers are the same as those used in Table 7.1.

Geographers, in company with other scientists, are finding it increasingly useful to classify and order the immense amount of data which are being amassed day by day. The geomorphologist may find it useful to classify the sediments he has studied so that additional information, if collected at a later date may be included within some sort of organised framework and its relevance within the conceptual framework judged.

In the present study it is possible to classify reasonably objectively, the samples of till analysed in the laboratory. It has already been suggested that it is possible to classify 52 samples of till, collected by the writer, into three broad categories representing those tills which are essentially of Pennine provenance, those which are essentially of extra-Pennine provenance and one sample which is not strongly associated with either of these two factors. This rather anomalous sample, no. 46, is interpreted by the writer as being very poorly mixed and has probably not been removed far enough from its bedrock source for it to have acquired proper Pennine characteristics.

Further sub-division and classification is possible and such a sub-division is illustrated in Figure 11.2. where category I has been further sub-divided into four;

- i. Tills with high shale contents.
- ii. Tills with high limestone contents.
- iii. Local tills without erratics.
- iv. Tills with small amounts of erratics.

It is essential to keep the sub-divisions as large as possible since to further sub-divide defeats the whole object of classification.

If one so wishes it would be possible, using the reasonable object classifications outlined above, to construct a till map which would be very similar to a soil map. Such a map would be more accurate than the drift maps at present being compiled and would certainly solve problems associated with boundaries.

The question arises as to whether or not it is worthwhile analysing so many variables in order to classify the tills. In this context factor analysis has many benefits. It has been shown that factor axes are

Fig. 11.2

# FACTOR LOADINGS I AND II

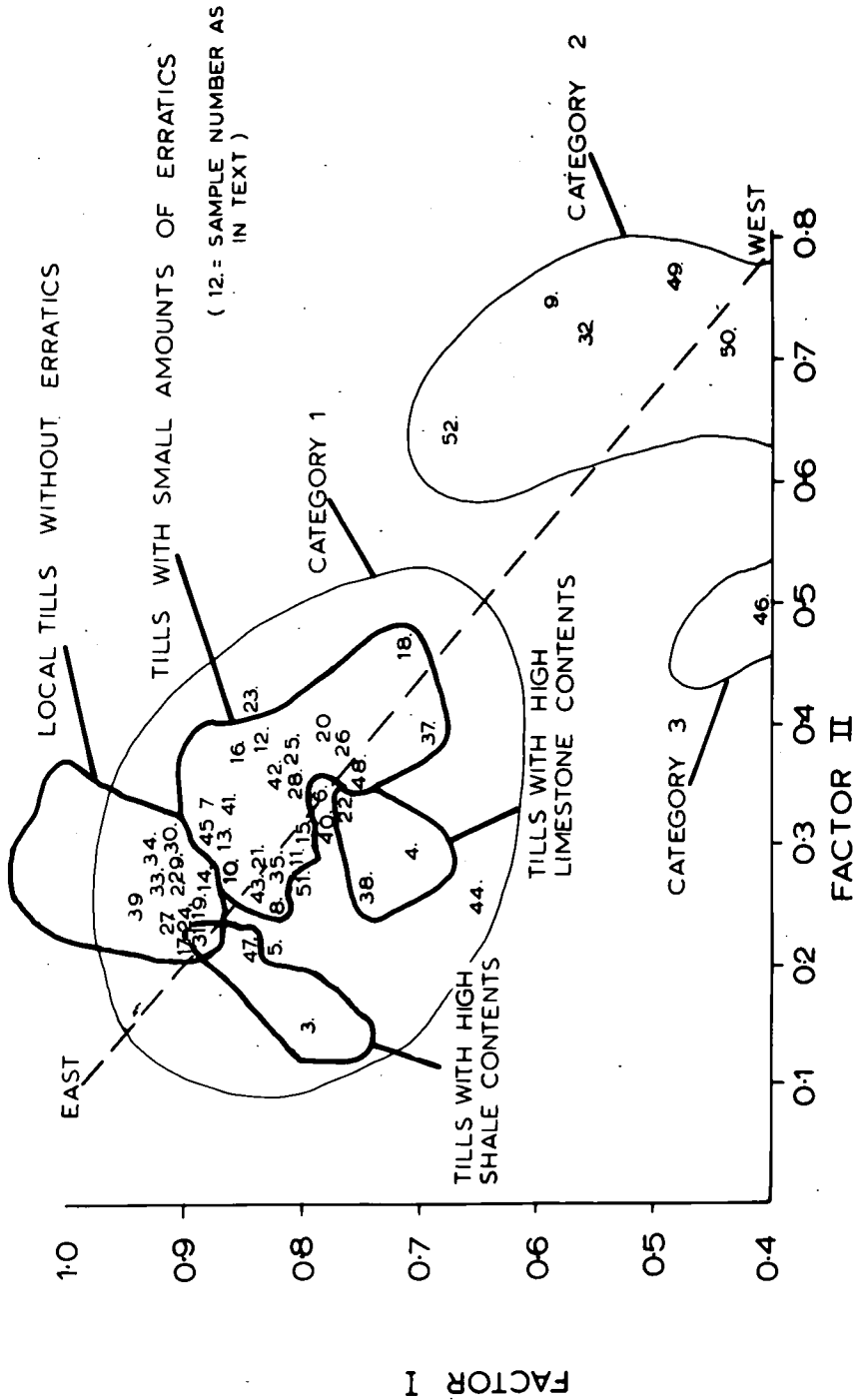


Fig. 11.3

# FACTOR LOADINGS I AND III

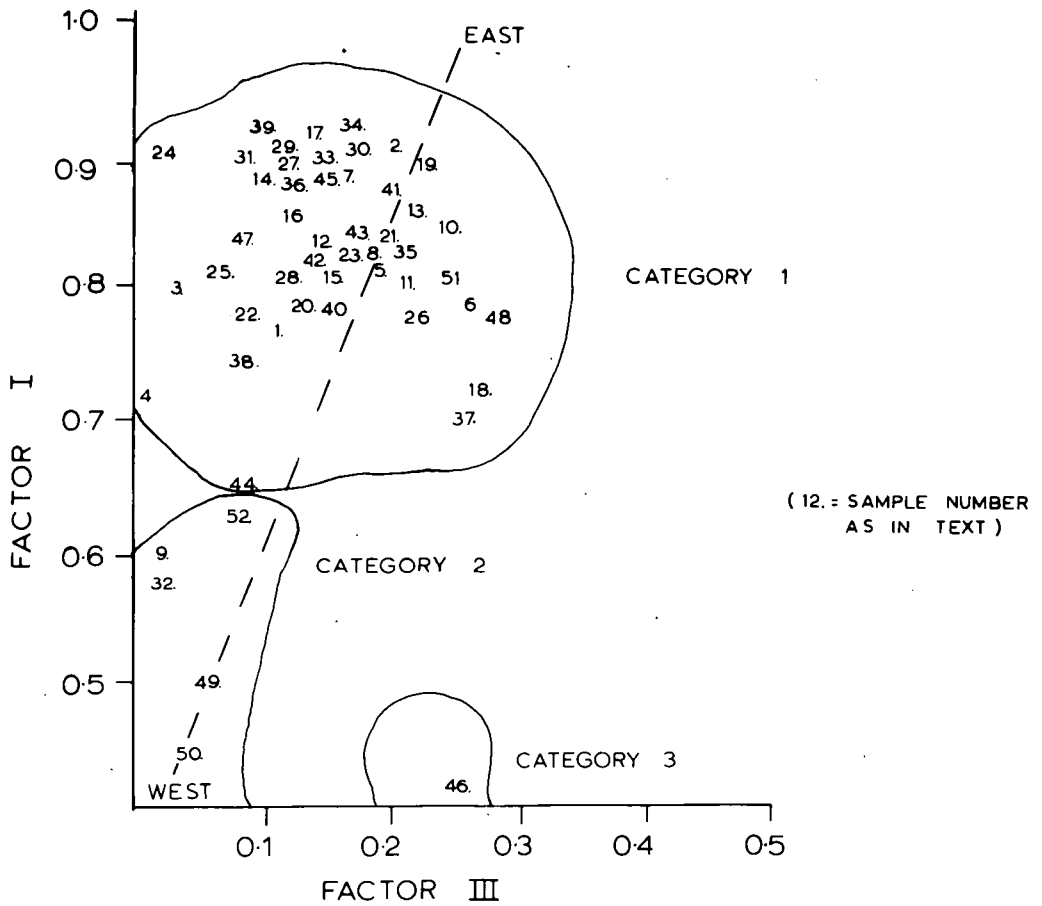
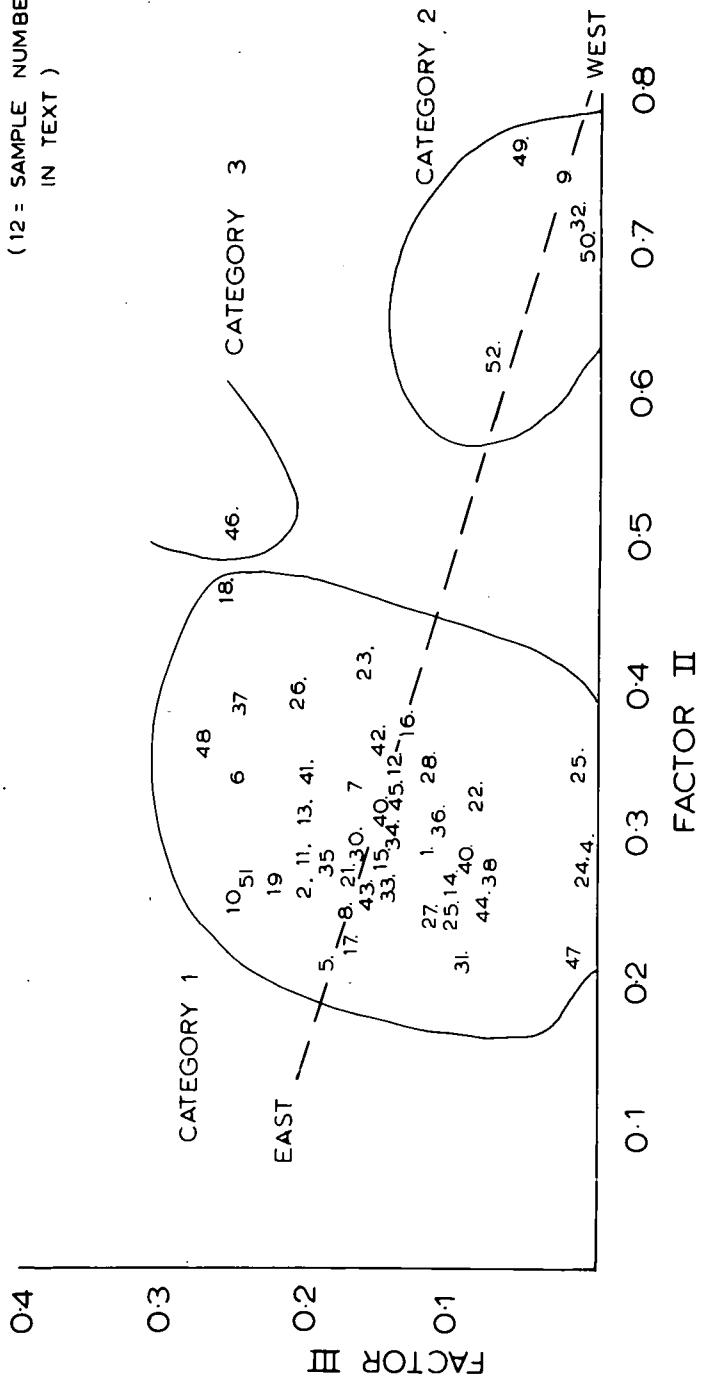


Fig. 11.4

# FACTOR LOADINGS II AND III

(12 = SAMPLE NUMBER AS  
IN TEXT )



associated with groups of variables which themselves are correlated and by an examination of the factor weightings it is possible to find out which are the most significant variables. Once these have been decided upon it would be possible to concentrate analyses on fewer significant variables and thus allow many more samples to be analysed.

b. Factor analysis in the study of provenance.

In very simple terms provenance may be considered as a simple binary system. One end member of such a system represents tills of the source region of ice dispersal, the other represents those tills down-ice of the source region. It has already been indicated that in the writer's study area the two end members are in fact factors I and II.

Now, if we accept the premise that incursive ice-sheets will gradually incorporate sediment into its base it follows that the nature of that sediment will change in a down-ice direction. If it is possible to arrange the samples, in terms of their overall sediment characteristics as measured by factor analyses, within such a binary system then it is possible to indicate the broad lines of ice movement.

In Figures 11.2, 11.3 and 11.4 it is evident that the samples are located around such a binary axis and are thus strung out between the two end members represented by high factor loadings on factors I and II. Samples with high loadings on factor II are found in the west of the study area (in an up-ice direction) while the most easterly samples in category 1 are those which load most heavily on factor I (Fig. 7.1).

Thus a factor analysis of the 52 samples of till from the north-west Alston Block has suggested that the major movements of ice which deposited the tills studied by the writer took place in a general west-east direction. The analyses also indicated that the sediments deposited by such an eastward moving ice-sheet are part of a simple binary system and are seen to evolve, in a sedimentological sense, in a general west-east, down-ice direction.

Conclusions.

As far as the writer is aware this is the first time that factor analysis has been applied to glacial tills. The analysis has indicated that in terms of 30 variables it is possible to objectively classify the 52

till samples into three reasonably distinct groups; further sub-division is possible, but less objectively based.

When the factor loadings of the 52 samples are plotted on factor axes a clear axial distributions is seen. Examination of the sample locations and stone counts indicated that in broad terms this axial distribution also indicates ice direction. The fact that the samples are axially located and not haphazard in distribution is also meaningful. This fact would seem to add weight to the writer's contention that the tills are organised deposits.

Their location about an axial line indicates that the tills are part of an evolving system. If this is the case then it is not likely that factor analysis would distinguish discrete clusters of samples. From this example it is seen that factor analysis locates each sample with respect to end members of the continuum.

In the writer's opinion the techniques of factor analysis has great promise in the field of glacial sedimentology. Where it is possible to distinguish two till sheets, for instance, factor analysis might be used to classify samples which were stratigraphically ambiguous.

Subjective assessments based on field work should never be far removed from statistical analysis. In factor analysis it has been shown that factors are mere mathematical extractions. One of the strongest tests of their reliability is to assess whether or not they are meaningful in a geomorphological context. This cannot be done without recourse to an initial appraisal based on field work.



## Chapter 12.

### Trend Surface Analysis.

".....there seems no reason, other than convention and lethargy, why they (trend surfaces) should not be very widely adapted for use in all branches of geography, both physical and human, in the immediate future".

(Chorley and Haggett, 1965).

#### Introduction.

Much effort in contemporary geography is directed towards the recognition, and subsequent explanation, of patterns and regularities in spatial distributions. Trend surface analysis seeks to separate broad scale variations, or trends, from local variations, or residuals.

Trend surface analysis can serve a number of useful roles of use to the geographer. King (1967) suggested four possible uses of such a technique. Firstly, trend surface analysis can provide quantitative descriptions of the areal pattern of a given variable. Secondly, trend surface analysis can be used to test a conceptual model. Thirdly, it may be used to predict or infer conditions. Fourthly, trend surface analysis can be used as a search procedure.

In this chapter trend surface analysis has been applied to a simple geomorphological model in an attempt to simplify, in an areal sense, much data collected in a laboratory analysis of 52 samples of till collected from the north-west Alston Block.

#### The technique.

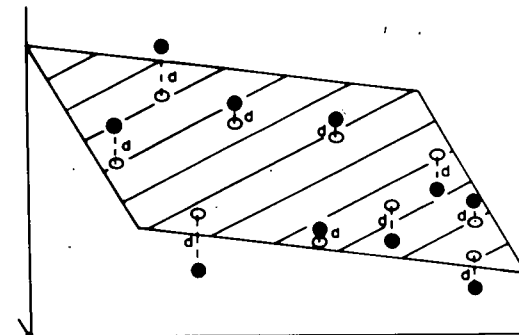
The basic aim of trend surface analysis is to fit surfaces of increasing complexity to sets of points in three dimensions. The positions of the points are defined by two sets of rectangular coordinates, while a third vertical coordinate has the values of the variable being analysed. A simple diagram best explains the idea (Fig. 12.1).

In practice, the trend surface is usually fitted to the data

12-1

Fig. 12.1

# LINEAR TREND-SURFACE



Distance  $d^2$  is Reduced to a  
Minimum by Best-Fit Surface

points using the least-squares criterion, in which the sum of the squared residuals is minimized. This method of fitting surfaces to the data distributed spatially is analagous to the calculations of a regression line in two dimensions. A regression line fits a distribution of points on a two dimensional surface. Trend surface analysis uses the third space dimension. The formulae must include two independent variables instead of the one used in regression analysis. Thus a regression line is defined by:

$$Y = a + bX$$

The general linear model is of the form:

$$Z = a_1 + a_2U_i + a_3V_j + e$$

where Z is the observed value of the mapped variable,  
 a's are polynomial coefficients,  
 $U_i, V_j$  are coordinates defining Z,  
 e is an error term.

The linear surface is useful in that it indicates the general trend of a distribution.

The actual configuration of the original statistical surface may be more closely approximated by fitting more complex surfaces. The linear is, in fact, only the first of a whole series of surfaces which can be fitted to spatially-distributed data points.

The quadratic, or second-degree surface assumes a "bowl- or saddle-shape", and is described by six coefficients:

$$Z = b_1 + b_2U_i + b_3V_j + b_4U_i^2 + b_5U_iV_j + b_6V_j^2$$

The cubic, or third degree surface is even more complex and is described by ten coefficients:

$$Z = c_1 + c_2U_i + c_3V_j^2 + c_4U_iV_j + c_5V_j^2 + c_6U_i^3 + c_7U_i^3V_j + c_8U_iV_j^3 + c_9V_j^3$$

Beyond the cubic are even higher order surfaces. However, as the surfaces become progressively more complex, and nearer reality, computation becomes increasingly slower, and at the same time interpretation more difficult. Moreover, to go much beyond the cubic tends to defeat the object

of the technique, which is to reduce complex reality to its more simplified, basic components for easier analysis.

### The significance of the trend surface.

Several methods have been used to assess the validity of the computed surfaces.

#### i. Percent sum of squares.

Several of the early users of trend surfaces, and even some workers to-day, have relied solely on percent sum of squares explanation which ~~is~~ provided with the computed output. A mathematical explanation of this measure is simple. A preliminary calculation involves summing the squares of deviations from the mean value of the variable in question. The sum of the squared deviations of the variable from the trend surface are then calculated and the amount of reduction from the total sum of squares is represented as a percentage.

A perfect fit of a trend surface would yield a value of 100 percent. With relatively low explanations in the percent sum of squares this measure, without recourse to a statistical test, becomes very subjective.

#### ii. Confidence limits.

Krumbein (1963) has shown that it is possible to compute confidence surfaces about a given trend. As indicated by Howarth (1967) and Krumbein and Graybill (1965) these are exceedingly difficult to calculate when the number of sampling points is large or the surface is higher than linear in order.

#### iii. Randomisation.

One approach to the problem of trend validity was that by Howarth (1967) who generated 60 sets of random numbers with random grid coordinates, there being 100 numbers in each set. From the results obtained Howarth estimated that, at the 95 percent level of significance, the minimum levels of explanation required for a non-random trend, based on 100 observations for the linear, quadratic and cubic surfaces were 6.0, 12.0 and 16.2 percent of the sum of squares respectively. One serious disadvantage of this method

of testing the data is the inordinate amount of computer time needed, time which may be very costly.

iv. Analysis of Variance.

The statistical significance of a trend may be tested by separating the source of variation into components. The objective is to determine if the components of a trend surface are statistically significant, or whether they probably reflect chance alone. Methods of computation of the analysis of variance are fully covered in Krumbain and Graybill (1965).

Norcliffe (1969) has published tables of percent sum of squares explanations for varying numbers of data points below which the calculated surface, using an F test, is not statistically significant. Norcliffe defines a random trend surface as one where a non significant F value is obtained. The required level of explanation for a given number of data points and at a given level of probability is calculated from the following formula (Norcliffe 1969):

$$G_{\alpha} = \frac{F_{\alpha} \cdot df.}{(N - df - 1)} \quad (100)$$

where,  $\alpha$  = set level of probability,

df = degrees of freedom,

N = number of sample points.

The analysis of variance test is the most used test of significance in trend surface analysis (Allen and Krumbain 1962; King 1967). It is not known how robust the F test is and several assumptions are implied on its application. One assumption is that repeated measurements at the same point will yield a frequency distribution of values of the dependent variable. The variance of this distribution is called the error variance and is assumed to be the same at all points on the surface. Obviously this assumption is not often met in most geomorphological and geological applications of trend surface analysis. A second assumption is that deviations from the surface are assumed to be mutually uncorrelated. In the present example this is most likely because of the inherent variability in the raw data. In conclusion

it is probable that the F test is a conservative test (Norcliffe, personal communication) though further than this it is not possible to go at the present state of our knowledge.

#### v. Visual Assessment.

Some workers, having obtained relatively low percent sum of squares explanations, have suggested that the surfaces are meaningful because they make sense in terms of the geomorphological model in question (Tinkler 1969; Unwin, personal communication). In the writer's view this is a relatively dangerous procedure as completely random trends may well satisfy the conceptual model under consideration.

#### The Geomorphological Model.

The use of trend surface analysis in this context follows principally from the results of the factor analytical experiments outlined in chapter 11. In that chapter it was shown how the 52 samples of till string themselves out between two important factors (sets of variables) which may be regarded as end members in a simple linear system, and that these end members could be related to a sedimentological evolution of the till in a down-ice direction. Naturally, the true picture is more complex because of the complex nature of reality, but the results of the factor analysis warranted further investigation.

One method of studying the overall pattern of the evolution noticed in the till samples is to construct trend surfaces for the variables measured for each sample. It has been shown in previous chapters that within the tills of the Alston Block, and with the 52 samples analysed, there is a great deal of inherent variability. One of the great advantages of trend surface analysis as a technique, is its ability to smooth out local variability and indicate a regional trend in the analysed variables.

Obviously, it is important to examine whether or not any meaningful trends exist at all, for if they do, then such results add conclusively to our evidence on the nature of organisation within till sediments.

A second point, following on from the above, is that if the tills are gradually changing in their characteristics in an areal sense then the

trends produced will be confirmatory evidence of the general ice movement.

The geomorphological model under examination is simple in concept. It is known that, at the maximum of the last glaciation, ice from the Lake District and south-west Scotland coalesced in the Eden Valley and poured over the Pennine watershed and through the Tyne Gap. Such ice would have been carrying with it a deposit which, by the very nature of the bedrock over which the ice had moved, was relatively rich in rock types which are absent from the sedimentary domain of the north-west Pennines. Once having entered such a domain the ice, where erosive, would have started to erode the sedimentary strata which would then be incorporated into the deposits at the base of the ice sheet. This process would have continued as the ice crossed the area.

By using the output maps printed in the computer programme it is possible to judge how quickly such changes, if any, in till characteristics took place. If similar studies could be carried out in other areas comparison of such rates of change might lead to useful information concerning the nature and rate of glacial erosion.

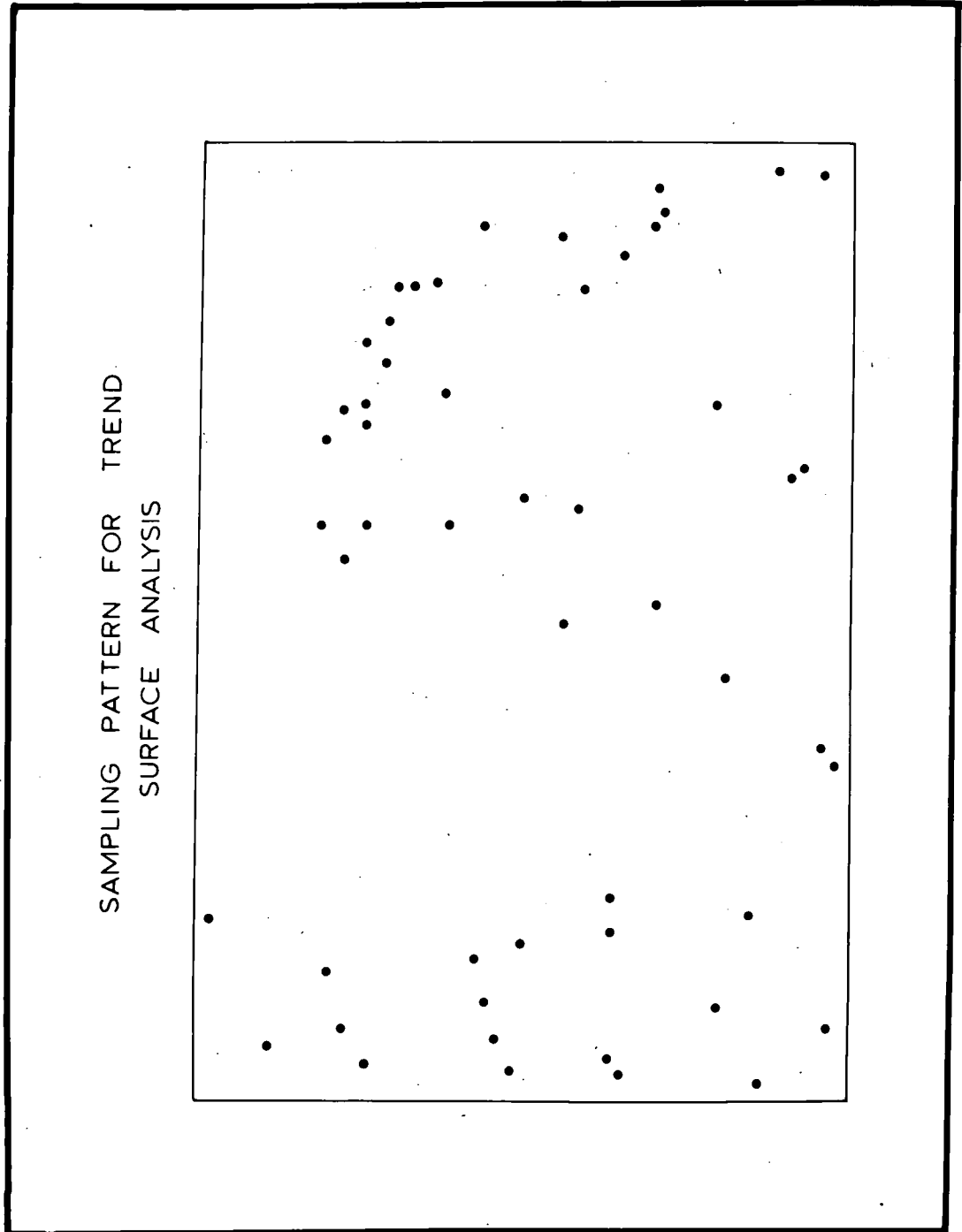
#### Input to the trend surface programme.

The computer programme used was by O'Leary, Lippert and Spitz (1966). Input to the trend surface programme consisted of 52 coordinate values corresponding to the sites where the till was examined (Fig. 12.2).

Ideally, in trend surface analysis, data sampling points should be fairly evenly spread. Unfortunately in many geomorphological studies it is not always possible to collect data in such a manner. In this study sampling was restricted for two reasons. Firstly, till is not everywhere exposed and the writer had to rely heavily on natural exposures. Secondly, till is not continuous over the study area. Although the writer made several attempts to find till on the large expanse of bleak moorland between the South Tyne and West Allen valley no till could be found. Presumably this area was a region of ice erosion rather than till deposition.

As one of the prime objectives of the analyses was to see if the deposits evolved in any particular direction it was obviously necessary to

Fig. 12.2





test whether such a configuration of sampling points imparted a more than random orientation to the computed surfaces. A simple way of examining this problem was to run 50 sets of 52 random values using the same point pattern as that shown in Fig. 12.2. The orientation of the linear surface was measured for each of the 50 surfaces. The results were then grouped into  $30^{\circ}$  sectors and tested with the Kolmogorov-Smirnov statistic (Siegel 1956) to see whether a higher than random number of observations occurred in any one sector.

The results of the Kolmogorov-Smirnov test was as follows:

Calculated sample D	0.1891
Tabulated D (95 percent level of probability)	0.1923

As the calculated D value is less than the tabulated it is concluded that the sampling pattern as seen in Figure 12.2 is not imposing a preferred orientation on the linear trend surfaces.

Trend surface analysis was performed on eleven variables which the writer thought might show evidence of ice direction. The variables are listed below:

1. Percentage of erratic material in the stone count.
2. Percentage of greywacke in the stone count.
3. Percentage of limestone in the stone count.
4. Percentage of tourmaline in the heavy mineral counts.
5. Percentage of carbonate in the till matrix.
6. Percentage of sand.
7. Percentage of silt.
8. Percentage of clay.
9. Phi mean particle size.
10. Phi sorting.
11. Percentage of coal in the till matrix.

The results of the analyses for each of the eleven variables and their geomorphological implications are discussed briefly.

i. Percentage of erratic material in the stone counts.

The results of a linear trend surface analysis for the percentage of erratic material in the stone counts is shown in figure 13.3. The percent sum of squares explanation for the linear surface is 29.0. Norcliffe's tables

(Norcliffe 1969) of minimum values of the percent sum of squares required under the F test for the trend to be non-random at the 95 percent level of probability shows that for 52 sample points values of at least the following are required:

12.9 percent sum of squares for a linear surface.

26.5 percent sum of squares for a quadratic surface.

46.0 percent sum of squares for a cubic surface.

The linear surface is, therefore, significantly different from random, using an F test.

In terms of the geomorphological model, described earlier in this chapter, the results are interesting. The linear surface shows that there is a meaningful change in the percentage of erratic material across the northern Alston Block. The general direction of the change <sup>is</sup> being from north-west to south-east. The linear surface, though only simple in form, does confirm in a general way the direction of ice movement. This is well illustrated in the northern reaches of the East Allen valley where the general direction of the slope of the linear surface and the direction of ice indicated by fabric analyses (Fig. 6.2) are very similar.

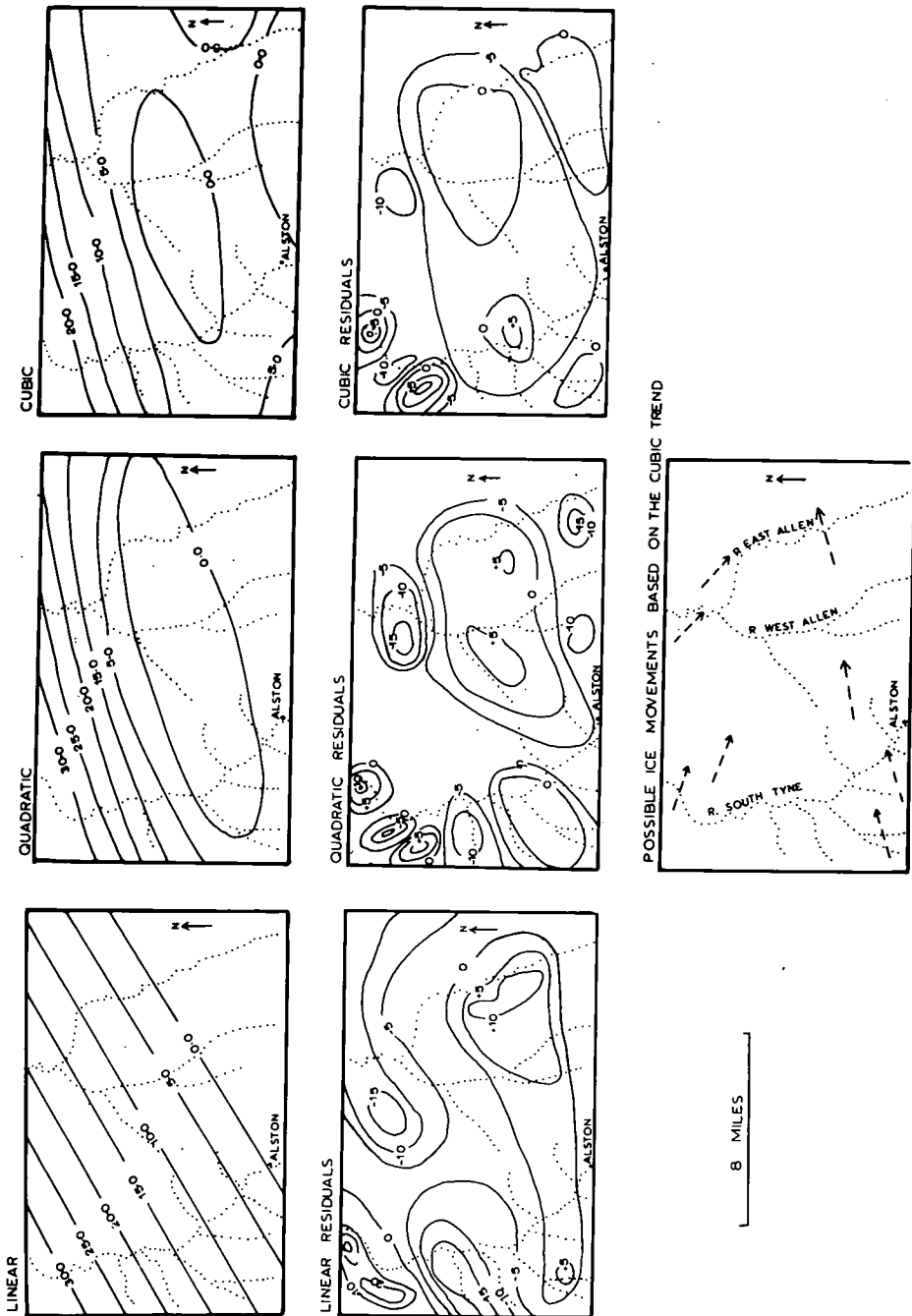
The quadratic surface accounts for 68.4 percent of the sum of squares explanation which is significant at the 95 percent level using an F test (the minimum limits for a non-random trend have been indicated earlier in this chapter).

This surface is more difficult to account for in terms of the geomorphological model but it may be seen (Fig. 12.3) that there is a marked slope in the amount of erratic material from the north-west. The general oval pattern of this surface is characteristic of the quadratic form.

A cubic surface accounted for 82.3 percent of the sum of squares explained which is significant at the 95 percent level (Fig. 12.3). This surface, which of those described best fits the actual data, raises some interesting possibilities concerning ice movement. A possible interpretation of the cubic surface will be outlined although it is realised that the data are open to alternative explanations. At this juncture it is worth reiterating that trend surface analysis can be used as a search procedure

Fig. 12.3

TRENDS OF THE PERCENTAGE OF ERRATICS IN THE TILL



(King 1967) and the questions raised by the results may be as important as the results themselves.

The northern half of the diagram (Fig. 12.3) is self explanatory and indicates a steep gradient in the percentage of erratic material in the till. This is possibly indicative of relatively rapid changes taking place in the lithological make-up of the till as a result of active erosion and incorporation of local, sedimentary lithologies. A central area with little or no erratic material in the till is suggested by the surface. Stone counts of the till in this region confirm the general lack of erratic material.

Erratic-containing till is also seen to creep into the south-western part of the diagram (Fig. 12.3) presumably indicating ice which crossed the South Tyne - Vale of Eden watershed, particularly south of the Butt Hill col.

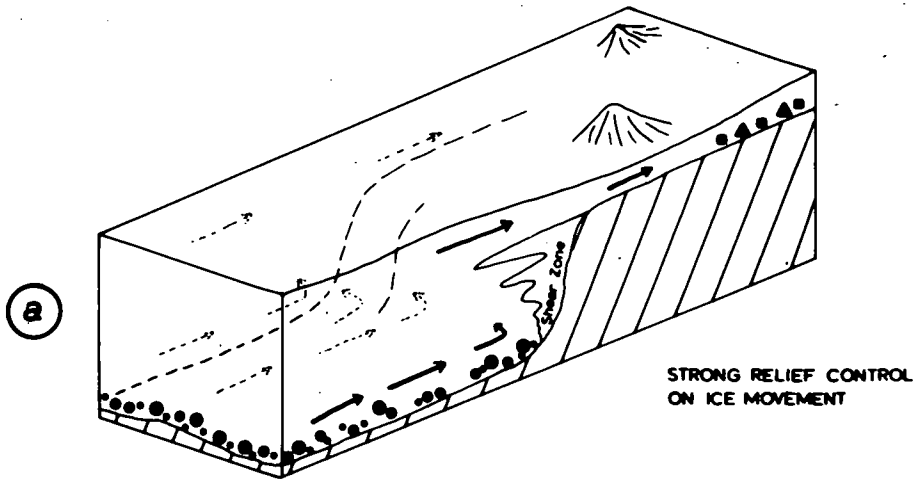
The cubic surface indicates a shallow ridge of erratic-containing till stretching in an easterly direction from the South Tyne to the East Allen valley. Stone count evidence proved the existence of erratic till in the upper East Allen valley and fabrics, together with evidence of ice direction from meltwater channels in the area indicated a westerly provenance for the deposit. The cubic surface would seem to indicate a possible direction for ice which could have deposited such a till. A zone of till without erratic material is indicated at the head of the East and West Allen valleys. This is confirmed by field and laboratory evidence.

One problem in the explanation outlined above is to account for the central area (Fig. 12.3) seemingly free of erratic material. One possibility which the present writer favours will be described. It is likely that not all the ice which poured over the South Tyne - Vale of Eden watershed would have contained erratic material. Some may have been clean ice relatively near the surface of the ice-sheet which occupied the Vale of Eden. Such ice would have been erosive once it started to stream across the watershed thus developing a local till at its base.

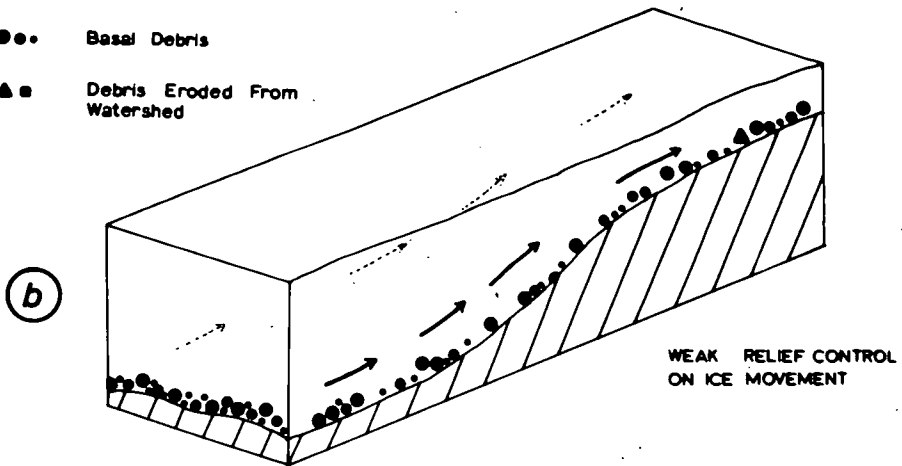
Where topographic controls allowed, such as in lower col areas, ice from nearer the base of the encroaching ice-sheet would have been able to ride up and pass over the watershed bringing with it erratic material. To some extent this possibility is confirmed by field evidence and also by the trend surface analysis. The two types of ice movement across the

Fig. 12.4

THE EFFECT OF DIFFERENT RELIEF-TYPES  
ON ICE MOVEMENT AND DEBRIS DISPERSAL



- Basal Debris
- ▲■ Debris Eroded From Watershed



South Tyne - Vale of Eden watershed outlined above are shown diagrammatically in Figure 12.4.

It can be seen in the cubic surface (Fig. 12.3) that till with more than 5 percent erratic material in the southern half of the South Tyne - Vale of Eden watershed is focussed on the Butt Hill col. This would seem to suggest that dirt-laden ice found its way over this low col. The conjectural ice movements suggested by trend surface analysis are shown in Figure 12.3.

An attempt was made to examine the residuals for each of the surfaces described in this chapter. Without exception the writer found it impossible to account, in a meaningful way, for such residuals. To illustrate this point the residual of the linear, quadratic and cubic surfaces of the percentage of erratic material in the till are shown in Figure 12.3. It has already been suggested that the till deposits of the north-west Alston Block have an inherent variability. Such variability, or 'noise', would give rise to residuals, which in terms of the overall trends, are not meaningful. This statement is to some extent confirmed by Krumbein and Graybill (1965 p.339) who state:

"Decisions such as these (referring to residuals) are entirely substantive and are based on background knowledge of field relations".

ii. Palaeozoic grits.

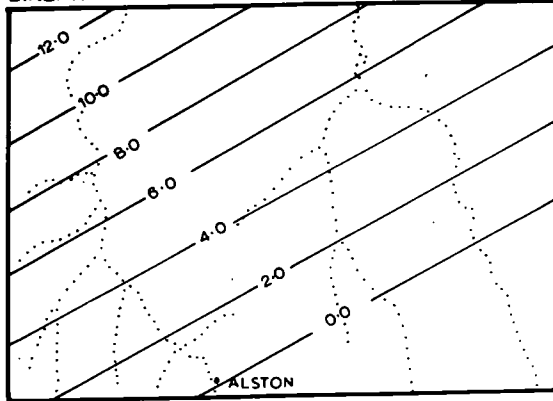
The Palaeozoic grits identified in the stone counts were mainly greywackes. The most likely source for such lithologies, in the present context, is the Southern Uplands of Scotland. For this reason the writer thought that an analysis of this variable might reflect a more northerly component from that when the total erratic assemblage was analysed.

The linear, quadratic and cubic surfaces accounted for 25.8, 63.0 and 78.1 percent of the sum of squares indicating that all three surfaces are significantly non-random using the F test limits. The linear surface (Fig. 12.5) is remarkably similar to that of the total erratic content and suggests that greywacke is well distributed throughout the erratic till. This was not unexpected as the tills of the Eden valley are relatively well mixed, both Scottish and Lake District lithologies being present.

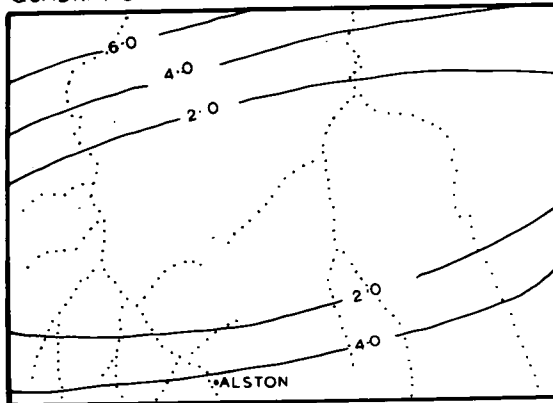
Fig. 12.5

# TRENDS OF THE PERCENTAGE OF GREYWACKE IN THE TILL

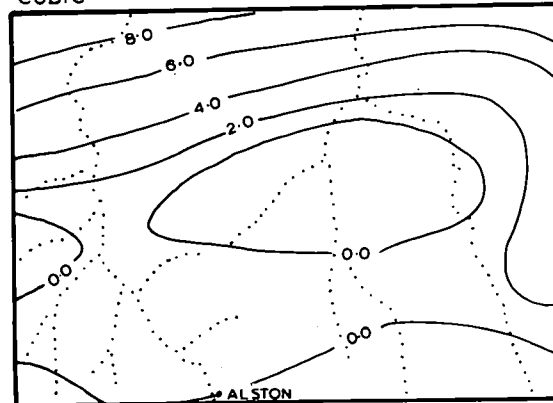
LINEAR



QUADRATIC



CUBIC



8 MILES

The quadratic and cubic surfaces are very similar in form to the total erratic trends (Fig. 12.3). It is possible, using the cubic surface, to suggest a similar pattern of ice movement. It is of interest to note that the ridge between the South Tyne and upper reach of the East Allen is also in evidence.

iii. Tourmaline content in the till.

It has been shown that an enrichment of the heavy mineral tourmaline in the fine sand fraction of the till is associated with the presence of erratic material in the sediment. For this reason it was decided to perform a trend analysis on the percentage of the heavy mineral tourmaline.

The linear, quadratic and cubic surfaces accounted for 28.2, 44.2 and 51.0 percent of the sum of squares respectively. All three values are significantly more than that required by an F test at the 95 percent level of probability. Trend surface maps for the linear, cubic and quadratic analyses are shown in Figure 12.6.

The linear surface is very similar to those described previously and confirms the association between the erratic material and the heavy mineral tourmaline. The quadratic surface assumes a similar pattern to the quadratic surfaces of the two variables already described. The cubic surface presents an interesting pattern which is difficult to interpret in terms of the simple model in question. The northern half of the surface shows the expected slope south denoting the dilution of the tourmaline content. Two large loops occupy the central area of Figure 12.6. One, with higher values is contained mainly within the South Tyne valley, while the other, with lower values is contained within the West and East Allen valley. The complexity of this surface in terms of the conceptual model is probably due to high amount of noise contained in the data due to the fact that the variable being studied is not totally foreign to the region, tourmaline being found with the sedimentary rocks of the Alston Block.

iv. Percent Limestone in the stone count.

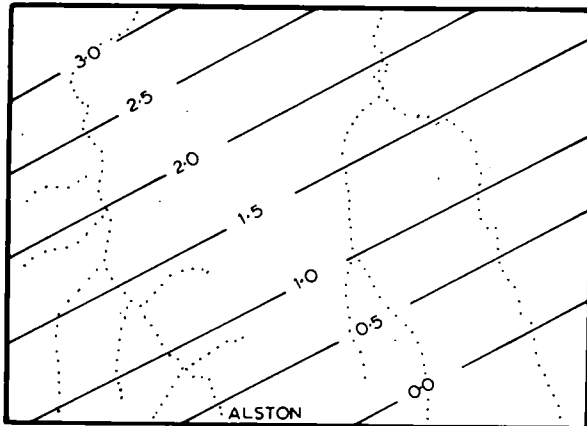
From field observations and from stone count evidence it was noticed that the tills found in the south of the study area, produced mainly by local ice, contained more limestone than the erratic tills brought into



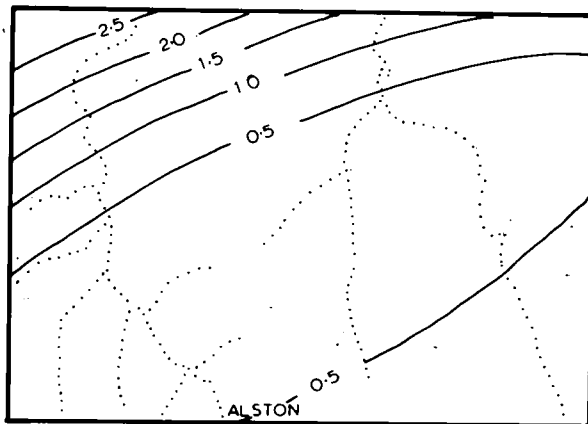
Fig. 12.6

# TRENDS OF THE PERCENTAGE OF TOURMALINE IN THE TILL

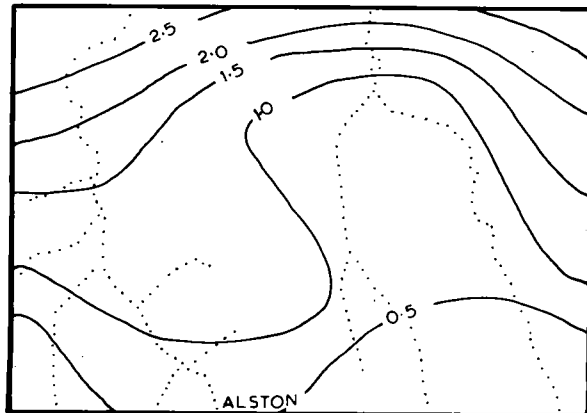
LINEAR



QUADRATIC



CUBIC



8 MILES

the area by ice sheets from the Lake District and Southern Scotland. To test whether or not there were any overall trends, meaningful in a geomorphological context, trend surface analysis was performed on the percentage of limestone as recorded in the stone counts. The linear, quadratic and cubic surfaces accounted for 18.8, 41.7 and 64.4 percent of the sum of squares and are therefore significant using the limits required under an F test. The linear, quadratic and cubic surfaces are shown in Figure 12.7.

The linear trend indicates, in a quantitative way, a decrease in the limestone content of the tills in a northerly direction. The quadratic surface, which appears like an upturned saddle (Fig. 12.7) reflects to a great extent the nature of the quadratic equation rather than the conceptual model. The cubic surface (Fig. 12.7) shows that at the head of the Allendale and South Tyne valleys the tills have a higher percentage of limestone in them than elsewhere in the study area. This result is in accord with the known outcrops of massive limestones which were eroded and incorporated into the till by local ice moving into the region from the south-west. Areas with less than 5 percent limestone, as seen in Figure 13.7 are those where erratic material is to be found. The 10 percent contour line might possibly represent the limit of the local incursion of ice, presumably emanating from Cross Fell, into the Allendale region.

#### v. Percent Coal.

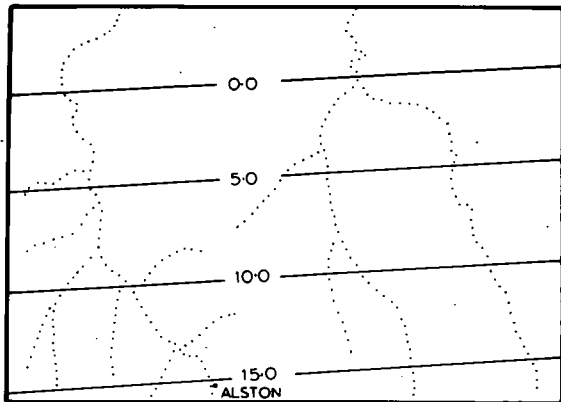
In chapter 2 it was seen that the rocks of the Yoredale cyclothem contain thin seams of coal. The writer thought that this variable might, therefore, be a useful indicator of provenance. As the ice crossed the area it would have incorporated such coal into its basal layers. Trend surface analysis of the coal content in the matrix of the tills accounted for 1.0, 3.8 and 11.9 percent of the sum of squares for the linear, quadratic and cubic surfaces respectively. These values were not sufficiently high for the computed surfaces to be regarded as non-random and it is concluded that no meaningful trend occurs in this variable.

#### vi. Percent Calcium Carbonate in the till matrix.

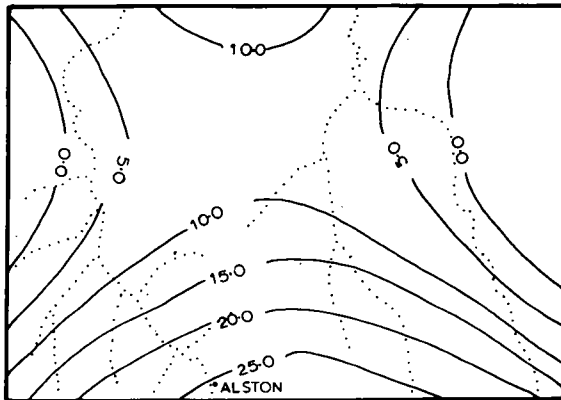
The amount of carbonate in a till matrix is to some extent dependent on lithology. It has been shown that a trend in the limestone content of the till takes place and it was, therefore, possible that a similar trend might occur

# TRENDS OF THE PERCENTAGE OF LIMESTONE IN THE TILL.

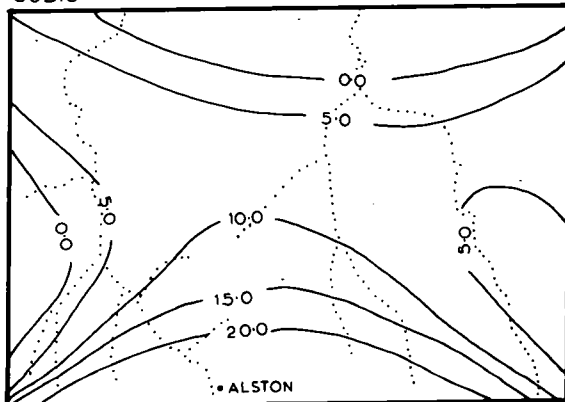
LINEAR



QUADRATIC



CUBIC



8 MILES

if the amount of carbonate in the till matrix was analysed. The percent sum of squares accounted for by the linear, quadratic and cubic surfaces were 10.9, 18.4 and 24.6 respectively. The percentage sum of squares of these surfaces, using the F test limits (Norcliffe 1969), are not <sup>sufficiently</sup> significantly high to be considered significant. The insignificance of a trend in this variable is probably due to the amount of noise, or variability produced at each site. Presumably, environmental factors such as pH are among those which contribute to such noise in the data.

To assess whether any trend occur in particle size characteristics of the tills of the north-west Alston Block, three parameters, percent sand, silt and clay, were analysed.

vii. Percent Sand in the till.

The percent sum of squares explanations for the linear, quadratic and cubic surfaces were, 3.6, 25.6 and 31.3 percent, respectively. These values were not high enough, using the F test, to indicate a non-random trend. No meaningful areal variation can be indicated using trend analysis on this variable.

viii. Percent Silt in the till.

Percent silt in the till matrix was analysed with the following percent sum of squares explanations, linear 5.7, quadratic 17.1 and cubic 35.7. These results were not high enough, using an F test to indicate a non-random trend.

ix. Percent Clay in the till.

The third sediment parameter utilized was the percent clay in the till. The values of the percent sum of squares explanation for the linear, quadratic and cubic surfaces were 12.0, 20.3 and 41.1 percent, and it was concluded that such values to not indicate non-random trends.

As these three simple measures, percent sand, silt and clay, were not useful in indicating trend in the till characteristics, it was decided to employ the phi mean and phi sorting parameters. These parameters use information from the total particle size curve.

x. Phi Mean of the tills.

The percent sum of squares for the linear, quadratic and cubic surfaces were 16.7, 34.6 and 37.3 percent respectively. The linear and quadratic values are greater than the limits required for a non-random trend, at the 95 percent level of probability, using the F test (at the 95 percent level the limits for a non-random linear and quadratic trend are 12.9 and 26.5 percent sum of squares explanation) and may be regarded as significant; the cubic surface is not statistically significant. The linear and quadratic trends are shown in Figure 12.8.

The linear surface indicates that the tills are becoming progressively finer grained in an easterly direction. Undoubtedly this is due to the incorporation of shale and mudstones which are derived from the Yoredale rocks which outcrop over a large part of the area.

The quadratic surface is difficult to interpret but coarse tills (containing a high percentage of limestone) are indicated in the south of the area and also in the north, where they contain high percentages of erratic material.

xi. Phi sorting of the tills.

The percentage sum of squares for the linear, quadratic and cubic surfaces are 0.4, 5.2 and 18.9 percent respectively and are not sufficiently high to be regarded as significant. It must be concluded that no significant trend in this variable exists in the present data.

Conclusion.

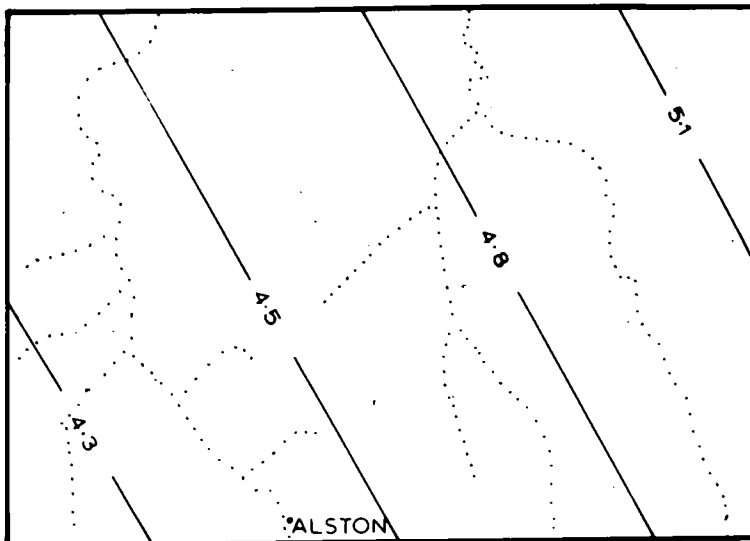
It is important to realise that trends with very high percentage sum of squares explanations were not expected during these analyses. By their very nature tills cannot be expected to contain the amount of order of a well sorted beach deposits or of fluvial sediments.

However, that valid trends exist for some of the variables analysed is encouraging and indicate that although there is a relatively high expected level of "noise" in the data gross overall trends are present in some of the variables.

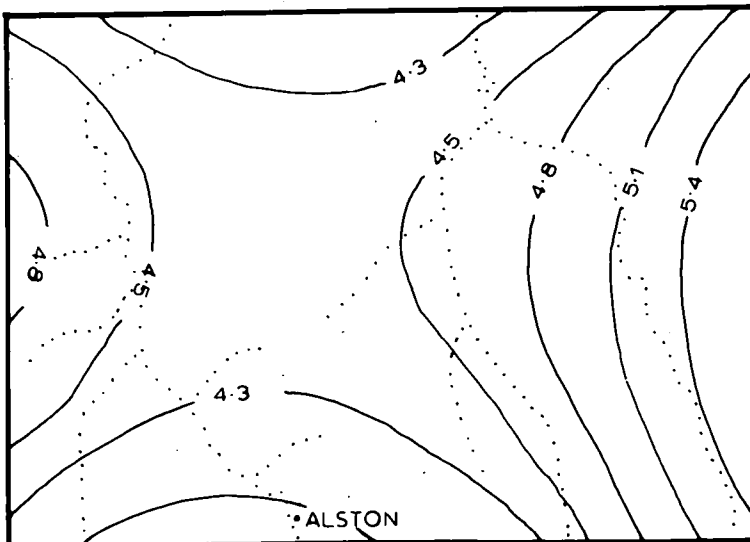
Fig. 12.8

# PHI MEAN TRENDS

LINEAR



QUADRATIC



8 MILES

Some variables, particularly those which are foreign to the north-west Alston Block and which could have only been introduced by incursive ice, are associated with significant trends which allow hypotheses to be made concerning ice movement.

While the surfaces themselves are not absolute proof of the direction of ice they are of great value if they substantiate evidence gained in the field. Even if such evidence is lacking several of the analyses have raised interesting indications of ice movement and have, therefore, warranted the application of trend surface analysis in the field of glacial geomorphology.

## Chapter 13.

### Ice Movements in the South Tyne and Allendale Valleys.

#### Introduction.

In this chapter all the available evidence is assembled in an attempt to reconstruct the pattern of ice movement during the various phases of the last glaciation. Detailed evidence for provenance and ice direction has been presented in earlier chapters and is drawn upon here where necessary.

Little evidence is available with which to reconstruct the later phases of deglaciation, after the period of maximum glaciation. For this reason it has been decided to divide, in arbitrary fashion, the stages of glaciation into an early, a maximum and late phases.

It is understood here that the various phenomena dealt with in this chapter are the product of the last glaciation. From our knowledge of the earlier, more extensive glaciations, it must be supposed that the study area was, at such times, glaciated. However, little evidence is available concerning the older glaciations of the area. At no exposure visited by the writer was an older, weathered, till seen to be overlain by a less weathered, younger till. Throughout the area studied by the writer the depth of weathering in the tills was remarkably constant at about 4 to 5 feet. This fact supports the writer's belief that the deposits are the product of a single glacial period.

Evidence concerning the age of the glacial features such as the meltwater channels is also limited but it should be mentioned that without exception the meltwater channels are quite fresh in appearance and where till is located in their floors it, too, is seemingly fresh, and never weathered to a depth of more than 5 feet. Of the till landforms it is possible to cite the fresh-looking drumlins in the South Tyne valley (Fig. 5.4) as evidence of the Weichselian age for the last glaciation.



It has previously been mentioned (Chapter 3) that radio-carbon dates on the Dimlington silts in Holderness suggest that the overlying sequence of Drab, Purple and Hesse Tills are of Late Weichselian age. Catt and Penny (1966) have suggested that the Drab Till of the Holderness sequence is the equivalent of the Lower Till of County Durham and that the Purple Till, with its abundant Permo-Triassic erratics is the equivalent to the Lake District Tills in the Upper Eden valley, which at the maximum of the last glaciation were carried over the Stainmore col into the Tees Lowlands and then on into the Holderness region.

From its erratic lithologies it is known that the Lower Till of County Durham has a westerly provenance and it can, therefore, be concluded that the Pennine Tills are of the same, Late Weichselian age.

Evidence of earlier glaciations is not forthcoming in the upland areas of the northern Pennines. However, if one considers the vast amounts of sediment that must have been eroded from the moorlands and carried into Lowland Durham it is not surprising that little evidence remains of these earlier inundations. Indeed, even in the surrounding lowlands there is, as yet, little evidence of glaciations earlier than the Weichselian. In a few coastal exposures in County Durham there exists small pockets of Scandinavian Drift (= the Basement Till of Holderness) which pre-dates the Lower Till and is, therefore, older, but it is quite possible that this too could be Early Weichselian rather than Saale in age.

Trotter (1929a) mentioned that in the Carlisle area there is evidence of an Earlier Scottish Till which is overlain by till of Lake District origin. No organic deposits have been found between these two tills and it is not possible to assign the Earlier Scottish Till to a glaciation earlier than the Weichselian. It seems likely that the Earlier Scottish Till merely reflects the fact that ice accumulation was more rapid farther north, where the firn line is known to have been lower (Manley 1959), and that ice from this northerly source began to spread southwards relatively early as compared with the ice accumulations which formed in the Lake District.

i. Earlier Phases of the Last Glaciation.

It has already been indicated (Chapter 4) that a local ice-cap existed on Cross Fell during the maximum of the last glaciation, and that at a later stage in the deglaciation a local valley glacier existed in the South Tyne valley. In the Cold Fell region, and also other areas of the Pennine watershed above 2000 feet O.D. it seems likely that an ice-cover was established prior to the inundation of the Alston Block by the "mer de glace" of Edenside. If an ice-cap had already established itself in the Cold Fell area it would have been large enough to keep encroaching Edenside ice at bay. The alternative explanation of the erratic-free area of Cold Fell is that the ice-cap was able to spread and remove erratic material at some stage of the glaciation when the Edenside ice was downwasting. From the firn line limits indicated by Manley (personal communication) (see Chapter 4) it is likely that the Cold Fell ice only remained active for a short period during this deglacial phase for the firn line would have soon risen above its summit.

In the Cross Fell area the summit plateau would have been well above the firn line some time before the maximum of the last glaciation. At the maximum of the glaciation the Cross Fell summit was approximately 1300 feet above the regional firn line (Manley 1955). If a sufficiently large accumulation of ice were able to develop on the Cross Fell summit area prior to the maximum of the last glaciation undoubtedly some would have found its way down the South Tyne valley as indeed it did after the Edenside ice had subsided. An early valley glacier stage in the South Tyne valley was also implied by Derryhouse (1902), Trotter (1929a) and Hollingworth (1932) all of whom suggested that the local ice in the South Tyne valley passed underneath ice from Edenside which crossed the South Tyne valley transversely. This would seem to require that a valley glacier was established at an early stage in the glaciation.

It would appear that the Allendales were ice-free during the last glacial maxima until inundated by ice from the west. Trotter (1929a) suggested that the high watershed to the south of the Allendales functioned as an ice-shed at the maximum of the last glaciation. The present writer cannot confirm this view indeed the evidence presented in this thesis, particularly the evidence from the meltwater channels at the head of the West Allen Dale,

would suggest that at the maximum of the last glaciation the upper parts of the Allendale valleys were under the influence of ice moving away from the Cross Fell area in a north-easterly direction. Now, if the watershed did not act as an ice accumulation centre during the maximum phases of the last glaciation it is hardly likely that they were accumulation areas during the earlier, less severe stages of glaciation. Certainly, the watershed at the head of the Allendales never accumulated ice in quantities which could have supplied local valley glaciers, as implied by Trotter (1929a). There is also a certain amount of climatological evidence to confirm this view, for if Manley's assumptions are correct (Manley 1955) the high firn line coupled with the shape of the watershed would have militated against there being any ice accumulation at the head of the Allendale valleys.

ii. Maximum Phases.

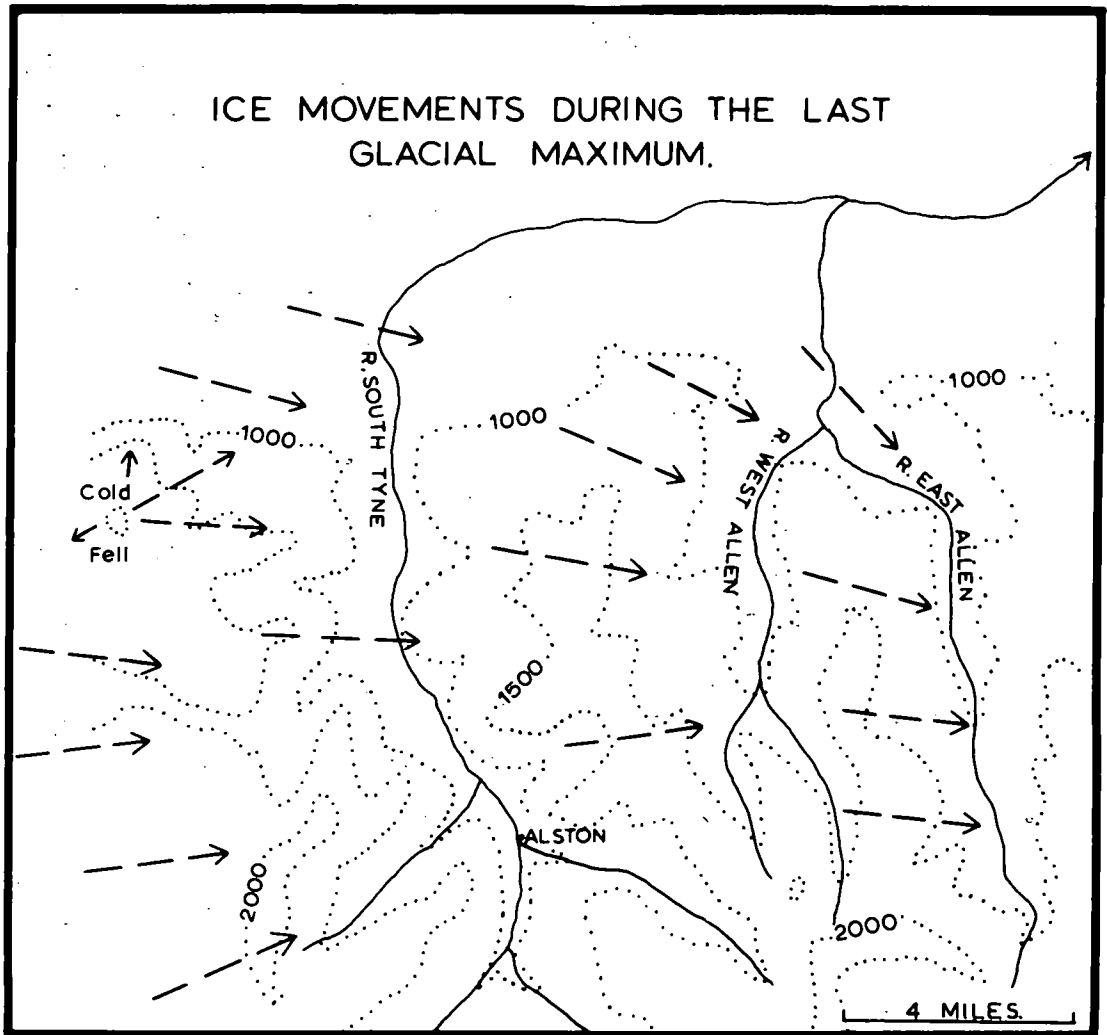
The pattern of ice movement at the maximum of the last glaciation, as suggested by the writer, is shown in Figure 13.1.

a. South Tyne valley.

The general nature of the movement of ice at the maximum of the last glaciation is indicated in Figure 13.1. There is abundant evidence to indicate that at the maximum of the last glaciation the South Tyne valley was inundated by ice from Edenside, only the Cold Fell region remaining unaffected. It has been shown, for instance, that a distinct reddish till with erratics is found in many of the west bank tributaries of the river South Tyne. This coupled with several stone orientations (Fig. 6.2) and the Butt Hill col channel indicate that at the maximum of the last glaciation thick ice in the Eden valley poured over the watershed into the South Tyne valley.

In order to explain the pattern of till distribution Dwerryhouse (1902), Trotter (1929a) and Hollingworth (1932) suggested that a local glacier passed down valley under the eastward moving Edenside ice. There seems little field evidence to support such ice movement and there is also some doubt as to whether such transverse flowage is physically possible. J. F. Nye (personal communication) has indicated to the writer that, in this context it is most unlikely that the two separate ice bodies would have been able to move in such a manner. Nye has suggested to the writer that shear

Fig. 13.1



traction of the Edenside ice passing transversely across the South Tyne valley would, in time, remove all traces of local ice from the valley bottom. The concept of a complete low level system of local ice moving down valley towards the Tyne Gap does not therefore appear tenable. Moreover, the distribution of the tills, with essentially erratic-containing tills occupying the sides of the South Tyne valley and an essential local till in the valley bottom is more easily explained if one accepts the writer's view that the valley glacier stage took place after the maximum inundation of ice. There is a certain amount of evidence to support this contention. For instance, the writer has already described that at various localities in the South Tyne valley reddish tills are seen to be incorporated into the local till created by the valley glacier. One such exposure is that at Softley (675555). In the writer's view it seems much more likely that there was a continuous cover of Edenside till in the South Tyne valley but at a later stage when the South Tyne glacier became dominant it effectively removed a great deal of this Edenside till. Only in the occasional exposure can one find traces of tills rich in erratics, as at Softley. Further evidence that at the maximum glaciation Edenside ice passed transversely across the South Tyne valley is provided by the tills containing erratics in the Snope Burn, an east bank tributary of the South Tyne (Fig. 1.2) and also the presence of erratics on the watershed to the east of the South Tyne valley.

b. West Allen Dale.

At the glacial maximum there is some evidence found in the north of the Dale that ice passed over the area from the north-west (Fig. 13.1). Not only do the tills contain erratics but several stone orientations also confirm the nature of this inundation (Fig. 6.2). The writer has mapped several meltwater channels which indicate such a direction (Fig. 5.8). The ice which deposited such till was probably at the edge of the Tyne Gap ice which, after pouring through the Tyne Gap, began to spread up onto the moorlands of the northern Alston Block to join that ice crossing the moorlands in an easterly direction which was derived directly from Edenside. It will be observed that this interpretation of the ice movements of this part

of West Allen Dale is at variance with Trotter's opinion (Trotter 1929a). In the writer's view the evidence from stone counts, stone orientations, meltwater channel orientations and the general directions of the linear trend surfaces cannot be ignored.

In the south part of the West Allen Dale the large subglacial meltwater systems on Allendale Common, between the West and East Allen Dales, indicates very clearly a west-east ice gradient. This gradient confirms the writer's general thesis that ice passed transversely, from west to east, across the north Pennines during the maximum of the last glaciation. Further evidence of ice movements in the upper part of the West Allen Dale during the last glacial maximum have been removed by the later advances of ice from the south-west.

c. East Allen Dale.

It has already been shown that in the East Allen Dale there are a great many exposures of till containing erratics. The most southerly of these exposures are those which occur near Sipton in the banks of the river East Allen. Without exception the erratics are very fresh and could have only been derived from the west or north-west. The presence of erratic material at Sipton, in the upper part of the East Allen Dale is difficult to interpret if one accepts Raistrick's views of the limits of erratics (Fig. 3.4). Furthermore Trotter's concepts of ice movement during the last glacial maximum do not fully explain the presence of erratic-containing tills so far south in the East Allen Dale. It is seen (Fig. 3.3) that Trotter indicated that at the maximum of the last glaciation the upper parts of the West and East Allen Dales were predominantly affected by local ice gathered on the watershed to the south. Only further north was this area fully under the influence of ice of a westerly provenance.

In the writer's opinion, the presence of these tills containing erratics merely confirms much other evidence, such as the meltwater channels of Allendale Common (Fig. 5.10) and Sinderhope Carrs (Fig. 5.11) which indicate that during the maximum of the last glaciation there was an ice gradient sloping in an easterly direction.

In the lower reaches of the East Allen Dale several stone orientations confirm the general direction of the incursive ice which was established for the West Allen Dale (Fig. 6.2). Undoubtedly a great deal of ice must have been concentrated in the Tyne Gap during the period of the last glaciation of the northern Pennines. In the Tyne Gap proper, relief of ice pressure would have probably come as a result of the ice moving faster, while once through the entrance of the Tyne Gap the ice would have spread out and thus<sup>would</sup> have rode up onto the Pennine moorlands. It is likely that this movement is reflected by the stone orientations in the lower East Allen Dale which indicate that ice was moving in a south-easterly direction (Fig. 6.2).

It has already been shown that both erratic-free and erratic-containing tills have preferred stone orientations which indicate a westerly or north-westerly provenance. It has previously been stated that such local tills appear uncontaminated by erratics and it is thought therefore that they too have a westerly origin. This conclusion is supported by various pieces of evidence. Firstly, at no exposure were erratic tills seen to overlie local tills. Secondly, as already mentioned, the local tills are relatively uncontaminated with erratics and if the stone orientations of these tills were secondary due to overriding one would expect the superimposition or the incorporation of erratic material. Thirdly, it is not envisaged by the writer that ice from Edenside was everywhere dirt-laden. As the ice thinned and streamed over the interfluves a local till would have been incorporated into the base of the ice and deposited side by side with erratic-containing tills. In the writer's view it is only by such a theory that the complex, but seemingly little mixed, tills of the East Allen Dale can be explained.

### iii. Late Phases.

It has not been possible to indicate specific stages in the deglacial history of the South Tyne and Allendale valleys. The evidence is very limited and it would be unwise to put forward such details until more evidence is available. Broad generalisations can be made and they indicate, in a general way, how the region was deglaciated.

There is a good deal of evidence to indicate that at some stage when the ice, issuing across the northern Pennines from the "mer de glace"

in Edenside, became less powerful the Cross Fell massif became a focal point from which ice streams radiated out. Ice from this source encroached into the South Tyne valley and West Allen Dale, and to a lesser extent into the East Allen Dale (Fig. 13.2).

Clear evidence of the dominance of the Cross Fell ice source at this stage of the glaciation in upper East Allen Dale is seen in the two meltwater channels which are found on the high watershed between the East Allen Dale and Weardale (Fig. 5.9). It will be recalled that these two meltwater channels are orientated towards the north and north-east indicating the regional ice-slope away from the gathering grounds to the south-west in the Cross Fell area.

Within upper East Allen Dale the tills are free from erratics and at two sites stone orientations (Fig. 6.2) confirmed the south-westerly provenance of this till. The writer cannot accept Trotter's view (Trotter 1929a) that the high watershed at the head of the East Allen Dale was itself an ice-shed at the glacial maximum (Fig. 3.3). If this were so it would, in the writer's opinion, be difficult to account for the fact that meltwater channels are only found on the northern slopes of the watershed. If such a local ice-shed had occurred then one would have expected to find meltwater channels draining both north and south of the ice-shed.

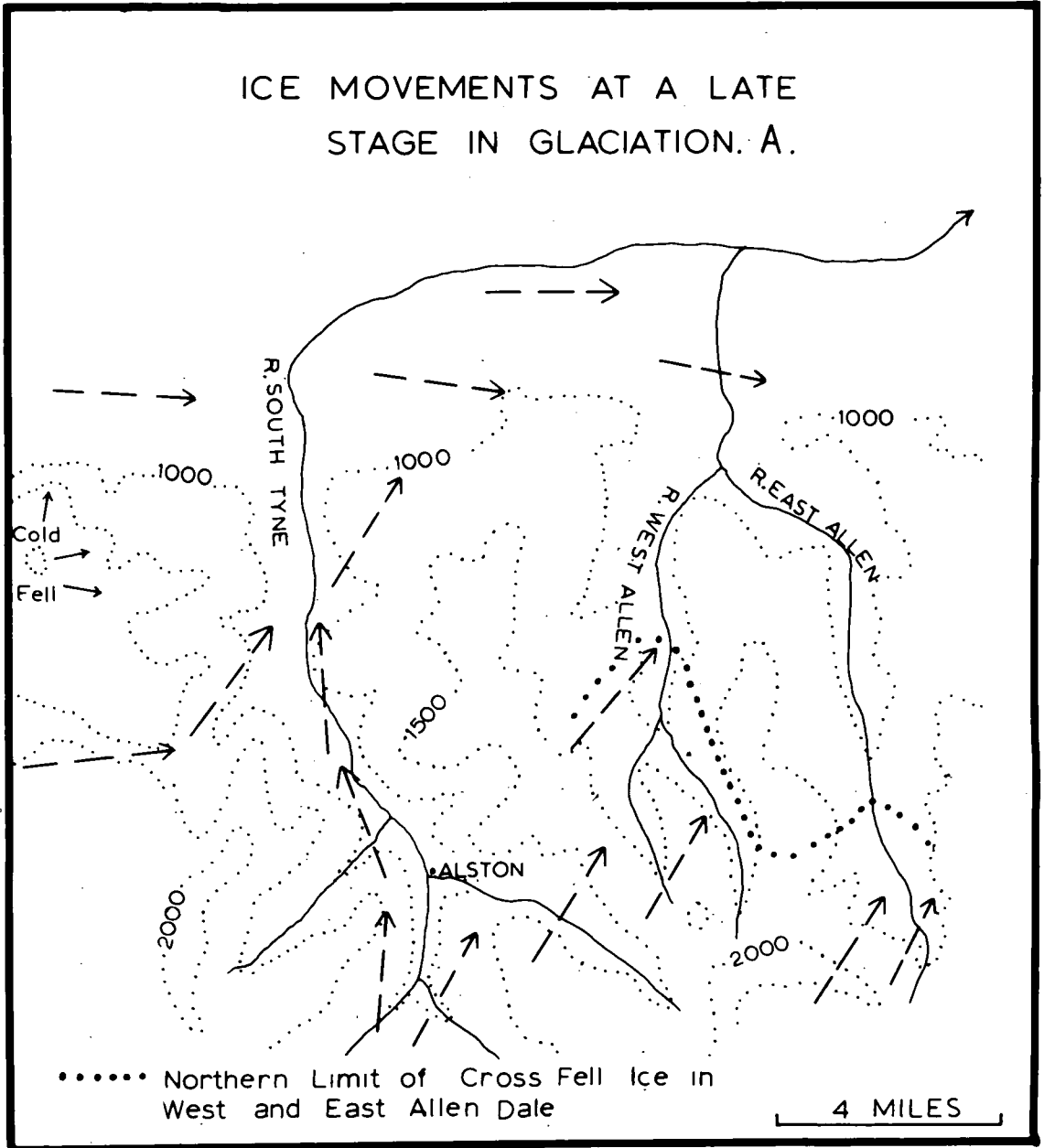
In terms of the regional setting it would be difficult not to accept the fact that Cross Fell, at this stage of the glaciation, was a dominant centre of ice dispersal. As the crow flies the watershed at the head of the East Allen Dale is only twelve or so miles north-east of the Cross Fell massif and nearly 1000 feet lower (Cross Fell is at 2930 feet O.D. while the average height of the watershed at the head of the East Allen Dale is c.2000 feet O.D.). Presumably, this difference in altitude would have been exaggerated during the last glaciation for ice accumulation on the Cross Fell area, with its lower regional firn line (Manley 1955) and its greater precipitation, would have been much greater.

If it is assumed, at a conservative estimate, that the altitudes of the ice surfaces in Cross Fell and the watershed at the head of the East Allen Dale differed by c.1000 feet this would imply an ice gradient of about



Fig. 13.2

ICE MOVEMENTS AT A LATE  
STAGE IN GLACIATION. A.



1.5% which would have allowed fairly substantial movements of ice away from the centre of dispersal. The estimated difference in the ice surface must remain conjectural for although it is certain that Cross Fell would have accumulated ice at a faster rate than the watershed at the head of the East Allen Dale it would also have dispersed the accumulated ice such that a steady state in the ice-dome may have existed. The ice gradient of 1.5% away from the Cross Fell plateau is of the same order as that calculated for the Scandinavian ice-sheet (c.1%), the present-day Antarctic ice-sheet (c.2%) and for many present-day plateau glaciers (c.2%) (Charlesworth, 1957).

In West Allen Dale the evidence for ice dispersal away from the Cross Fell area is particularly well demonstrated by the series of meltwater channels which trench the watershed at the head of the Dale (Fig. 5.6). These large subglacial meltwater channels clearly indicate that Trotter's view (Trotter 1929a) of ice flowing down the Nent valley towards Alston (Fig. 3.3), that is, in a north-westerly direction, during the last glaciation is difficult to accept. If the meltwater channels at the head of the West Allen Dale indicate that the regional ice-slope during a later phase of the glaciation was towards the north-east it is difficult to see how ice at the main stage of glaciation moved north-westerly down the Nent valley.

Further evidence of the inundation of ice at this stage into the head of the West Allen valley is the presence of local till to within a short distance of the watershed at the head of the Dale (Fig. 4.2). Two stone orientations in this local till both indicated a south to south-westerly provenance rather than a westerly one. The northern limit of Cross Fell ice in the West Allen Dale is indicated on Figure 13.2. Although this limit is somewhat conjectural there are several lines of evidence which suggest that it is approximately correct. One stone orientation near the junction of the Wellhope and West Allen rivers indicates a south-south-westerly provenance (Fig. 6.2). Of particular importance in this context are the meltwater channels on Ouston Fell (Fig. 5.7) which by their north-easterly direction clearly indicate the nature of the ice gradient at the time of their formation. These two facts coupled with stone count evidence which indicated that the tills to the south of the limit of Cross Fell ice indicated on Figure 13.2 provide a body of evidence supporting the writer's view.

In the South Tyne valley it is likely that the Cross Fell ice had established a general flow of ice down the South Tyne valley. At this stage in the glaciation topographic controls were very important in influencing the pattern of ice movement. Gradually the high watershed between the River South Tyne and the Vale of Eden would have emerged from the ice thus effectively cutting off supplies of Edenside ice to the South Tyne valley. The South Tyne valley was no longer under the influence of the "mer de glace" in Edenside and the ice pattern had changed from a general west-east inundation to a northwards flowing valley glacier supplied by the Cross Fell ice-dome.

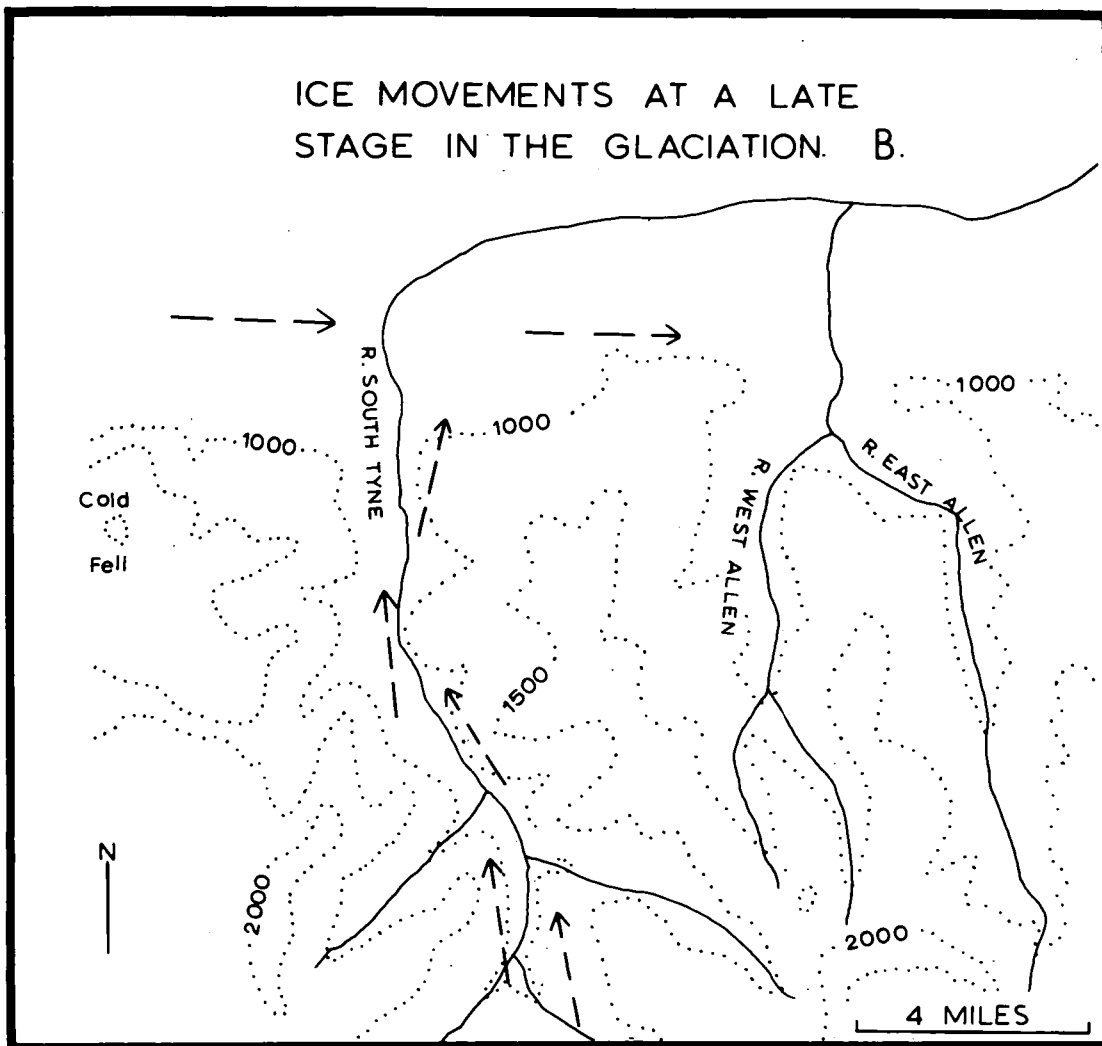
As more and more of the Cold Fell - Hartside Height watershed emerged from the wasting Edenside ice-sheet the influence of this westerly ice became progressively weaker. The last ice from Edenside poured into the South Tyne valley through the low col centred on Butt Hill (Figs. 1.2 and 13.2).

The ice which poured down the South Tyne valley did much to remove traces of erratic-rich till stranded at lower levels in the South Tyne valley but failed to remove foreign tills deposited at higher levels. This would suggest that South Tyne valley glacier took some time to establish itself and only after it was considerably reduced in size did it become efficient in removing deposits previously stranded in the valley. (Fig. 13.3).

Much evidence has been presented to indicate the activity of this glacier. Several drumlins have been recognised indicating active ice moving towards the Tyne Gap within the confines of the valley (Figs. 5.4 and 5.5) and both stone orientations and striae indicate similar ice movements along the axis of the valley (Fig. 6.2). Not all the Edenside deposits were removed from the lower levels of the South Tyne valley and it will be recalled that the tills do contain erratics in samples of till collected from the northern parts of the valley.

It has been noticed that the distance down the valleys of the South Tyne, East and West Allen Dale reached by Cross Fell ice was to a great extent determined by the height of the watershed at the head of the valleys. In the East Allen Dale the inundation of Cross Fell ice was relatively short-lived for the watershed, which is here generally at c.2000 feet O.D. would

Fig. 13.3



have soon emerged from the ice. A longer period of inundation was probable in the West Allen Dale where local ice reached further down valley. Neither the West nor the East Allen Dale had its own local supply of ice and once the high watersheds to the west and south emerged from the ice cover the ice would have been stranded in the valley bottoms.

While ice was either dying in situ or slowly wasting down towards the Tyne Gap in the Allendales Cross Fell ice was still able to pass down the South Tyne valley. A great many meltwater channels have been recorded in the South Tyne valley most of which indicate that even when the ice became relatively thin there was still a marked ice gradient towards the north.

Several phases of retreat of this valley glacier are indicated by spreads of outwash (sites 2,4, 5 Fig. 5.3) and two moraines (Fig. 5.3 and 5.5).

The writer would like to point out that the valley to valley chronology as indicated in Figure 13.2 is only intended to be relative, only rarely can detailed comparative studies be made.

### Conclusions.

In conclusion to this chapter it might be pertinent to answer, in the light of the evidence presented in this thesis the questions raised in the prologue to section 2 of this thesis.

In reply to the question concerning the nature of the ice cover during the maximum of the last glaciation the writer would conclude that ice-free areas did not exist.

Several possibilities of ice movement during the maximum glaciation have been suggested by previous workers in the area. The present writer would conclude by saying that at the maximum of the last glaciation the incursive ice was dominant in the South Tyne and Allendale area and effectively held ice produced in the Cross Fell region at bay.

Trotter (1929a) suggested that local valley glaciers existed in the West and East Allen valleys and such glaciers flowed northward underneath the ice moving in an easterly direction across the northern Pennines. The present writer has found no evidence which suggests that the Allendales harboured their own valley glaciers but rather that ice from Cross Fell poured over the watershed

at the head of the Allendales at a stage in the glaciation after the Edenside ice had become a less powerful influence on regional ice movements.

In answer to the vexed question as to whether or not ice-dammed lakes existed in the study area the writer must conclude that the extensive waterbodies envisaged by Dwerryhouse (1902) and Raistrick (1931) have either left insufficient evidence for their being traceable in the landscape as it is seen today or that they did not exist at all. Certainly, it has been shown that lakes indicated by inferences from meltwater channels did not exist. If waterbodies existed at all, as for instance those proven in the East Allen Dale, they were associated with the wasting of ice stranded in the valleys after the surrounding watersheds had emerged from the ice and effectively cut off their supply of ice.

No conclusion would be complete without mentioning several of the problems which still remain to be solved. In particular it would be very interesting to know exactly how thick the ice was that passed over the Pennine watershed from the Vale of Eden. It would also be very satisfying to find some organic deposits which would irrevocably date the age of the tills independently of stratigraphical extrapolations. It is to be hoped that such problems may stimulate further research in this neglected area of the Pennines.

## Chapter 14.

### Conclusions.

#### Introduction.

The results described in this thesis are the outcome of two quite separate, but complementary, methods of investigation. In part they have been derived from a formal field investigation in which the glacial sediments and landforms have been examined. While this method has been used successfully, and is used still successfully, the amount, and kind, of data obtained from such investigations depends to a very great extent on the nature of the field area. In the northern Pennines, with their lack of the spectacular and general absence of exposures and glacial landforms, it is necessary to supplement such investigations with other methods. In this study a great deal of factual and objective data has been obtained from a sedimentological study of the glacial deposits. These methods are time consuming and tedious, but so too are normal field investigations. With the advance of science and the development of new apparatus it is likely that such laboratory investigations may soon be more automatic and require less operator time. It is the writer's opinion that the objective data obtained as a result of laboratory investigations more than justifies the time consumed by such techniques.

Over the past sixty years or so a great body of information has been built up concerning the glacial landforms of Great Britain, yet little information is available concerning the glacial deposits themselves. Beaumont (1967) has indicated that the glacial deposits may well hide clues as to the processes occurring during the development of glacial landforms and he has stressed the general lack of such information in Great Britain as compared with North America.

It is hoped that the data provided in this thesis will contribute in a small way to a store of factual information which might further our knowledge as to the fundamental processes at work during the glaciation of a region.

## Main Conclusions.

1. In Chapters four and five the glacial deposits and landforms are described. At the maximum of the last glaciation the distribution of fresh unweathered erratics requires a wholesale inundation of Edenside into the South Tyne and Allendale valleys. Some ice poured into the area over the high Cold Fell - Cross Fell watershed while other ice streamed through the Tyne Gap and rode up onto the moorlands in the north of the study area. Only the Cold Fell area, which had its own local ice-cap, remained free of Edenside ice at this period. In the South Tyne the drumlins and moraines provide additional evidence that at a late phase of the glaciation the valley was occupied by a local glacier. In East Allen Dale it is concluded that much ice downwasted in situ creating an ideal environment for the formation of bodies of water between the stagnating ice lumps. True lacustrine sediments are described and are thought to have been deposited in such an environment.

2. The meltwater channels of the South Tyne and Allendale valleys are described and their relation to ice movement indicated. As the ice, at the stage of the maximum glaciation, began to waste a number of large sub-glacial channels were initiated which show little regard for topography. The pattern and field relationships of such features indicate that they were not formed as lake spillways, a mode of formation suggested by earlier workers in the area (Dwerryhouse 1902; Trotter 1929a).

As the ice surface lowered into the valleys a number of sub-glacial and submarginal channels were formed indicating an ice slope to the north. The details of the deglacial phases could not be indicated as few marginal meltwater channels have been recognised.

3. The provenance of the deposits indicated in Chapter 4 and also the nature of the ice slopes indicated in Chapter 5 are confirmed by stone orientation studies.

As well as a general inundation by Edenside ice fabrics studies in the South Tyne valley and the upper West and East Allen Dale indicate an advance of local ice having its source in the Cross Fell area. The



presence of such a north-easterly flow of Pennine ice explains the lack of Lake District and Scottish erratics from Upper Weardale. The ice movement indicated above would have effectively cut off Weardale from Lake District and Scottish ice advances.

4. The objective raw data provided by stone counts (Chapter 7) has been used in a number of statistical analyses. It has been used to show how, in the South Tyne valley, the decrease in the limestone percentage indicates the direction of ice movement and also quantitatively illustrates how rapid the mechanical breakdown of coarse limestone particles is in the glacial environment.

Stone counts have also been used to classify the tills into those which contain erratics, termed foreign tills, and those which are erratic-free, termed local tills.

5. In Chapter 8 the particle size of 52 samples of till were analysed. In terms of absolute range it has been shown that the sand, silt and clay percentages of the tills of the north-west Alston Block are similar to those described by Beaumont (1967) in eastern Durham.

The linear relationship between sand and clay percents described by Beaumont (1967) has not been observed in the tills of the South Tyne and Allendales, due to a more variable silt content. It is proposed that this variability is mostly due to the fact that the tills of the uplands of the Alston Block are rapidly evolving sediments unlike the well mixed tills of lowland Durham where areal changes in sediment characteristics are slower.

Beaumont (1967) has indicated that the percentage of sand, silt and clay in a till may be a diagnostic property determined by the mode of deposition of the till, or may be due to parent material. In this study the writer has also suggested that it may also be dependent on the relative stage of development of the till. In terms of sand, silt and clay percentages it has not been possible to distinguish meaningful groups of till in the north-west Alston Block.

Total particle size analysis of 52 samples of till revealed a significant correlation between the mean particle size and sorting values. Such an association indicates that some degree of order is present in the sediments.

A number of correlation analyses were performed between percentages of various lithological groups and percentages of gravel, sand, silt and clay, determined from the total particle size analysis. Several statistically significant results were obtained which suggest that there is a lithological control over the total particle size parameters of a till. For instance, it has been found that till with higher percentages of erratic material in the stone counts are also sandier and that tills with higher percentages of shale in the stone counts are siltier.

6. In Chapter 9 the carbonate, coal, pH and ferric iron content of the till matrix were examined for 52 samples of till. The absolute range of carbonate values varied from 1.0 to 32.5 percent. Relatively low percentages of carbonate in those tills with high percentages of limestone in the stone count suggested that the carbonate of the coarser fraction had not been broken down into the matrix indicating that the till had probably not moved far from its bedrock source. On the other hand several erratic-containing tills had high percentages of carbonate in their matrix. Such carbonate, which had probably been derived in part from the limestones outcrops which surround the Lake District had, by the time the till had reached the Pennines, been totally incorporated into the matrix. This confirms Dreimanis's view (Dreimanis 1960) that the matrix of the till provides a good reflection of the more distant components. In the present context the distances involved are of the order of thirty miles and are much shorter than those indicated by Dreimanis (1960).

The pH values show a general relationship to the carbonate values. High carbonate contents are generally associated with high pH's.

The relationship between ferric iron content and till colour as determined by a Munsell colour chart was studied. Many of the local tills contained higher percentages of ferric iron than did the reddish, erratic-containing tills. Statistical analysis showed that there was a high correlation between the ferric iron content of the till matrix and the shale percentage in the stone count.

All the tills analysed contained some coal in their matrix. The absolute range of values varied from 0.01 to 0.5 percent by weight. Without exception the coal content of the tills analysed was lower than the coal content of their lateral equivalent, the lower till of the Wear Lowlands (Beaumont 1967). The increase in coal content towards the east is due to the tills having passed over outcrops of the Coal Measures.

7. A qualitative X-ray study of five representative till samples indicated that the most common clay minerals were illite, kandite and quartz. The three local tills analysed also had identifiable peaks of calcite, the intensity of which was shown to correlate with the amount of limestone in the stone counts. X-ray analysis indicated that the crystalline iron mineral in the clay fraction of the red tills from Edenside was hematite, while the principal iron mineral in the local tills was goethite. It was concluded that the colour difference between the local and foreign tills was due principally to this difference in iron minerals.

8. Two advanced statistical methods were used in Chapters 11 and 12. Factor analysis was used to indicate if any meaningful groups of till emerged when several variables were taken into consideration. The results of the analysis suggested that rather than specific groups there existed a continuum with very local and foreign tills as end members. Such a distribution is strong evidence that the tills were evolving, sedimentologically, as they passed over the study area.

The areal evolution indicated by the factor analysis was studied in detail using trend surface analysis. Several variables were shown to change areally indicating their evolution in a down-ice direction. Several of the higher order surfaces indicated movements of ice during the maximum glaciation which are remarkably similar to the model proposed by the writer in Chapter 13.

9. In Chapter 13 all the available information has been used to indicate the movement of ice during the maximum and later phases of the glaciation of the study area. It is concluded that at the maximum phase of glaciation the

study area was covered by ice from Edenside only the Cold Fell areas escaping inundation. At a later stage there is much evidence to support the conclusion that the Cross Fell became an important area of ice dispersal which send powerful streams of ice down the South Tyne valley and also into the heads of the West and East Allen Dale. As the ice surface lowered the supply of Cross Fell ice was cut off progressively earlier from east to west and at a final stage was supplying ice to a local valley glacier in the South Tyne which itself was gradually retreating up valley.

## Epilogue.

One of the prime objectives of this study was to show how, by piecing together detailed evidence from both field and laboratory studies, the nature of the ice movement and various stages in the history of the last glaciation could be reconstructed.

All too often till deposits have been examined in a cursory manner in the field probably because they were thought to be so poorly organised, sedimentologically, as to be not worthy of further attention. This view is supported neither by the results presented in this thesis nor by the evidence beginning to accumulate which suggests that tills are far from being the pell-mell sediments indicated by earlier workers in this field.

A second objective of this study was to make it as integrated as possible by using a wide range of statistical and laboratory methods as well as standard field techniques. It no longer seems satisfactory to rely solely on one method of study to the exclusion of all others. Furthermore, a great many interesting relationships, themselves of geomorphological interest, have come to light as a by-product of such integrated studies.

BIBLIOGRAPHY.

## BIBLIOGRAPHY.

- ALLEN, P., and KRUMBEIN, W.C., 1962 "Secondary trend components on the top of the Ashdown Pebble Bed: a case history".  
Journ. of Geol. 70. pp.507-538.
- ALLEN, V.T. 1930 "Petrography of the weathered zones of glacial deposits".  
Bull. Geol. Soc. Am. 41. pp. 85-86.
- ANDERSON, R.C. 1955 "Pebble lithology of the Marseilles Till Sheet in north-eastern Illinois".  
Journ. of Geol. 63. pp. 214-227.
- ANDERSON, W. 1940 "Buried Valleys and the late glacial drainage system in north-west Durham".  
Proc. Geol. Ass. 51. pp. 274-287.
- ANDREWS, J.T. 1963 "The cross valley moraines of north-central Baffin Island, a quantitative analysis".  
Geog. Bull. 20. pp.82-129.
- ANDREWS, J.T. and INGLE SMITH, D. 1966 "The variability of till fabric".  
British Geomorph. Res. Group. Occ. paper No. 3 pp.33-37.
- ANDREWS, J.T., and SIM, V.W., 1964 "Examination of the carbonate content of drift in the area of Foxe Basin".  
Geog. Bull. 21, pp.41-53.
- ANDREWS, J.T. and SMITHSON, B.B., 1966 "Till fabrics of the cross valley moraines of north-central Baffin Island".  
Bull. Geol. Soc. Am. 77, pp. 271-290.
- ANTEVS, E. 1951 "Glacial clays in Steep Rock Lake, Ontario, Canada".  
Bull. Geol. Soc. Am. 62. pp.1223-1262.
- ASHLEY, G.D. 1961 "Northumberland".  
Soil Survey of England and Wales Report No. 14. pp. 4-6.
- BEAUMONT, P. 1967 "The glacial deposits of eastern Durham".  
Univ. Durham Ph.D.
- BEAUMONT, P., TURNER, J. and WARD, P.F. 1969. "An Ipswichian peat raft in glacial till at Hutton Henry, Co. Durham".  
New Phytol. 68, pp.797-805.
- BHATTACHARYA, N. 1962. "Weathering of glacial tills in Indiana. I. Clay Minerals".  
Bull. Geol. Soc. Am. 73, pp. 1007-1020.

- BIK, N.J.J. 1966. "New methods in alpine glacial geomorphology".  
Zeitschrift fur Geomorphologie. 10, pp.302-310.
- BISAT, W.S. 1948. "Sand and silt residues from Yorkshire Coast boulder clays".  
Trans. Leeds, Geol. Assoc. 6, pp.57-71.
- BOSWELL, P.G.H. 1916. "The petrology of the North Sea Drift and Upper Glacial Brick-Earths in East Anglia".  
Proc. Geol. Ass. 17, pp. 79-98.
- BOSWELL, P.G.H. 1928. in, E. Greenly: "Some recent work on the submerged forest in Anglesey".  
Proc. L'pool. Geol. Soc. 15, pp.60-62.
- BOTT, M.P.H. 1961. "A gravity survey off the coast of north-east England".  
Proc. Yorks. Geol. Soc. 33, pp. 1-20.
- BOTT, M.P.H., and JOHNSON, G.A.L., 1967. "The controlling mechanism of Carboniferous cyclic sedimentation".  
Quart. Journ. Geol. Soc. 122, pp.421-441.
- BOTT, M.P.H., and MASSON-SMITH, D. 1957. "The geological interpretation of a gravity survey of the Alston Block and the Durham coalfield".  
Quart. Journ. Geol. Soc. 113, pp.93-136.
- BOULFON, G.S. and WORSLEY, P., 1965. "Late Weichselian glaciation in the Cheshire-Shropshire basin". Nature 207, pp.704-706.
- BOWEN, D.Q., and GREGORY, K.J. 1965. "A glacial drainage system near Fishguard, Pembrokeshire".  
Proc. Geol. Ass. 76, pp.275-281.
- BRADLEY, W.F., GRIM, R.E. and CLARK, G.L., 1937. "A study of the behaviour of montmorillonite upon wetting".  
Z. Kristallogr. 97, pp.216-222.
- BREWER, R. 1955 "Mineralogical examination of a yellow podsolc soil formed on granodiorite".  
C.S.I.R.O. (Aust.) Soil Publ. No. 5, p.28.
- BRINDLEY, G.W. 1966. "Discussions and recommendations concerning the nomenclature of clay minerals and related phyllosilicates".  
Clays and Clay Min. 14, p.27.
- BRINDLEY, G.W. 1967. "Clay mineral nomenclature".  
Clays and Clay Min. 15, p.437.
- BRITISH REGIONAL GEOLOGY, 1935. "The South of Scotland".  
Pringle, J., H.M.S.O. London.
- BRITISH REGIONAL GEOLOGY, 1953, "Northern England".  
Eastwood, T., H.M.S.O. London.



- BRITISH REGIONAL GEOLOGY. 1954. "The Pennines and adjacent areas".  
Edwards, W. and Wray, D.A., H.M.S.O. London.
- BRITISH STANDARDS (1377), 1961. "Methods of testing soils for civil engineering purposes".  
British Standards Institution, London.
- BROPHY, J.A. 1959. "Heavy mineral ratios of Sangamon weathering profiles in Illinois".  
Illinois. Geol. Survey Circ. no. 273, pp. 1-22.
- BROWN, G. (ed.) 1961. "The X-ray identification and crystal structure of clay minerals".  
Mineralogical Society, London.
- BULMAN, G.W. 1891. "On the origin of the Upper Drift sands and gravels of Northumberland".  
Naturalist. (Feb.) pp.43-45.
- BURGESS, I.C. and HARRISON, R.K. 1967. "Carboniferous basement beds in the Roman Fell District, Westmoreland".  
Proc. Yorks. Geol. Soc. 36, pp.203-225.
- BUTTERFIELD, J.A. 1940. "A petrological study of some Yoredale sandstones".  
Trans. Leeds. Geol. Ass. 5, pp.264-284.
- CARRUTHERS, R.G. 1939. "On Northern Glacial Drifts".  
Quart. Journ. Geol. Soc. 95, pp.299-333.
- CARRUTHERS, R.G. 1947-1948. "The secret of the glacial drifts".  
Proc. Yorks. Geol. Soc. 27, pp.43-57, pp. 129-172.
- CARRUTHERS, R.G. 1953. "Glacial Drifts and the Undermelt Theory".  
S. Hill - Newcastle.
- CATT, J.A. and ROBINSON, P.C. 1961. "Preparation of thin sections of clays".  
Geol. Mag. 98, pp.511-514.
- CATT, J.A. 1963. "Stratigraphical investigations in the Pleistocene deposits of Holderness, East Yorkshire".  
Univ. Hull Ph.D. thesis.
- CATT, J.A. and PENNY, L.F. 1966. "The Pleistocene deposits of Holderness, East Yorkshire".  
Proc. Yorks. Geol. Soc. 35, pp.375-420.
- CHARLESWORTH, J.K. 1957. "The Quaternary Era". 2 Vols.  
Arnold, London.
- CHORLEY, R.J. 1964. "An analysis of the areal distribution of soil size facies on the Lower Greensand rocks of east-central England by means of trend surface analysis".  
Geol. Mag. 101, pp.314-321.

- CHORLEY, R.J. and HAGGETT, P. 1965. "Trend-surface mapping in geographical research".  
Trans. Inst. Brit. Geog. 37, pp.46-47.
- CLAPPERTON, C. 1966. "The influence of topography on the superimposition of glacial meltwater streams".  
British Geomorph. Res. Group. Occ. paper No.3., pp.13-18.
- CLAYTON, K.M. and BROWN, J.C. 1958. "The glacial deposits around Hertford".  
Proc. Geol. Ass. 69, pp.103-109.
- COLE, J.P. and SMITH, G.A. 1967. "An introduction to factor analysis with the United States as an example".  
Bull. Quant. data for Geographers, No.8.
- COMMON, R. 1957. "Variations in the Cheviot meltwater channels".  
Geogr. Stud. 4, pp.90-103.
- CORNWALL, I.W. 1958. "Soils for the Archaeologist".  
Phoenix House, London.
- CURRAY, J. 1867. "On the drift of the north of England".  
Quart. Journ. Geol. Soc. 23, pp.40-43.
- CURRAY, J.R. 1956. "The analysis of two-dimensional orientation data".  
Journ. of Geol. 64, pp.117-131.
- DAVIS, S.N. 1958. "Size distribution of rock types in stream gravel and glacial till".  
Journ. Sed. Petrol. 28, pp.87-94.
- DE GEER, G. 1912, "A geochronology of the last 12,000 years".  
C.r. 11th int. geol. Congr. (Stockholm, 1910) 1, pp.241-258.
- DE JONG, J.D. 1953. "Heavy mineral analysis as a method to study the structure of glacially contorted ridges".  
Actes 4 Congr. Intern. Quaternaire, Roma - p.303.
- DERBYSHIRE, E. 1961. "Sub-glacial col gullies and the deglaciation of the north-east Cheviots".  
Trans. Inst. Brit. Geogs. 29, pp.31-46.
- DERRY, D.R. 1933. "Heavy mineral of the Pleistocene beds of the Don Valley, Toronto, Canada".  
Journ. Sed. Petrol. 3, pp.113-118.
- DODSON, M.H. and MOORBATH, S. 1961. "Isotopic ages of the Weardale Granite".  
Nature 190, p.900.
- DOUGLAS, D.J. 1946. "The interpretation of the results of mechanical analysis".  
Journ. Sed. Petrol. 16, pp.19-40.

- DONNER, J.J. and WEST, R.G. (1957). "The Quaternary geology of Brageneset, Nordaustlandet, Spitsbergen".  
Norsk Polar Inst. Skrifter, 109.
- DREIMANIS, A. 1959. "Measurement of carbonate leaching in the service of Pleistocene stratigraphy".  
Geol. Foren. Stockholm. Forhan. 81, pp.478-484.
- DREIMANIS, A. 1960. "Significance of carbonate determination in a till matrix".  
Bull. Geol. Soc. Am. 71, p. 1853 (Abstract).
- DREIMANIS, A. and REAVELY, G.H. 1953. "Differentiation of the Lower and Upper till along the north shore of Lake Erie".  
Journ. Sed. Petrol. 23, pp.238-259.
- DREIMANIS, A., REAVELY, G.H., COOK, R.J.B., KNOX, K.S. and MORRETTI, F.J. 1957. "Heavy mineral studies in the tills of Ontario, and adjacent areas".  
Journ. Sed. Petrol. 27, pp.148-161.
- DROSTE, J.B. 1956a. "Alteration of clay minerals by weathering in Wisconsin tills".  
Bull. Geol. Soc. Am. 67, pp.911-918.
- DROSTE, J.B. 1956b. "Clay minerals in calcareous tills in north-eastern Ohio".  
Journ. of Geol. 64, pp.187-190.
- DUNHAM, K.C. 1948a. "The Geology of the Northern Pennine Orefield, Vol. I - Tyne to Stainmore".  
Mem. Geol. Survey. Eng. and Wales.
- DUNHAM, K.C. 1948b. "Lower Carboniferous sedimentation in the Northern Pennines (England)".  
Rep. 18th Int. Geol. Congr. pt. iv. pp.46-63.
- DUNHAM, K.C. 1953. "Red coloration in desert formations of Permian and Triassic age in Britain".  
19th session Int. Geol. Cong. (Algiers) 7, p.25.
- DUNHAM, K.C., BOTT, M.P.H., JOHNSON, G.A.L. and HODGE, B.L. 1961. "Granite beneath the northern Pennines".  
Nature 90, pp. 899-900.
- DURAND, D. and GREENWOOD, J.A. 1958. "Modifications of the Raleigh Test for uniformity in analysis of two dimensional orientation data".  
Journ. of Geol. 66, pp. 229-238.
- DWERRYHOUSE, A.R. 1902. "Glaciation of Teesdale, Weardale and the Tyne Valley and their tributary valleys".  
Quart. Journ. Geol. Soc. 58, pp.572-608.

- EDEN, W.J. 1955. "A laboratory study of varved clays from Steep Rock Lake, Ontario".  
Am. Journ. Sci. 253, pp.639-674.
- EMBLETON, C. 1956. "Late-glacial drainage in part of north-west Wales".  
Proc. Geol. Ass. 67, pp.393, 404.
- EMBLETON, C. 1961. "The geomorphology of the Vale of Conway, with particular reference to its deglaciation".  
Trans. Inst. Brit. Geogs. 29, pp.47-70.
- EMBLETON, C. 1964. "Sub-glacial drainage and supposed ice-dammed lakes in north-west Wales".  
Proc. Geol. Soc. 75, pp.31-38.
- EMBLETON, C. and KING, C.A.M. 1968. "Glacial and Periglacial Geomorphology".  
Arnold, London.
- FLINT, R.F. 1942. "Glacier thinning during deglaciation".  
Am. Journ. Sci. 240, pp. 113-116.
- FLINT, R.F. 1949. "Leaching of carbonates in glacial drift and loess as a basis for age correlation".  
Journ. of Geol. 57, pp.297-303.
- FLINT, R.F. 1957. "Glacial and Pleistocene Geology".  
J. Wiley and Sons, New York.
- FOLK, R.L. and WARD, W.C. 1957. "Brazos river bar: a study in the significance of certain size parameters".  
Journ. Sed. Petrol, 27, pp. 3-26.
- FRIEDMAN, G.M. 1961. "Distinction between dune, beach and river sand from textural characteristics".  
Journ. Sed. Petrol. 31, pp.514-529.
- FRIEDMAN, G.M. 1962. "Comparison of moment measure for sieving and thin section data in sedimentary petrological studies".  
Journ. Sed. Petrol. 32, pp. 15-25.
- FRYE, J.C., WILLMAN, H.B. and GLASS, H.D. 1960. "Gumbotil, Accretion-gley and the weathering profile".  
Illinois State Geol. Sur. Circular. 295.
- GAUDETTE, H.E., EADES, J.L. and GRIM, R.E. 1966. "The nature of illite".  
Clays and Clay Min. 13, p. 33.
- GILLBERG, G. 1955. "Den glaciala utvecklingen inom Sydsvenska hoglandets vastra randzon".  
Geol. Foren. Forhand. 77.

- GILLBERG, G. 1965. "Till distribution and ice movements on the northern slopes of the south Swedish Highlands".  
Geol. Foren. Forhand. 86, pp.433-484.
- GILLBERG, G. 1967. "Further discussion of the lithological homogeneity of till". Geol. Foren. Forhand. 89, pp.29-49.
- GILLBERG, G. 1968. "Distribution of different limestone material in till".  
Geol. Foren. Forhand. 89, pp.401-409.
- GILLBERG, G. 1968. "Lithological distribution and homogeneity of glacio-fluvial material".  
Geol. Foren. Forhand. 90, pp. 189-204.
- GILLBERG, M. 1965. "A statistical study of till from Sweden".  
Geol. Foren. Stockholm. Forhand. 87, pp.84-108.
- GILLIGAN, A. 1919. "The petrology of the Millstone Grit of Yorkshire".  
Quart. Journ. Geol. Soc. 75, pp.251-294.
- GJEMS, O. 1967. "Studies on the clay minerals and clay mineral formation in the soil profiles in Scandinavia".  
Norwegian Forest. Res. Inst. Rep. 81.
- GJESSING, J. 1960. "Isavsmeltingstidens drenering, dens forlop og formdannende virkning i nordre Atnedalen".  
Ad Novas 3, 492p.
- GLEN, J.W., DONNER, J.J. and WEST, R.G. 1957. "On the mechanism by which stones in till become orientated".  
Am. Journ. Sic. 255, pp.194-205.
- GODWIN, H. and CLAPHAM, A.R. 1951. "Peat deposits on Cross Fell, Cumberland".  
New Phytol. 50, pp.167-171.
- GOLDTHWAITE, R.P. 1959. "Leached clay-enriched zones in post-Sangamonian drifts in south-western Ohio and south-eastern Indiana: a reply".  
Bull. Geol. Soc. Am. 70, pp.927-928.
- GOODCHILD, J.G. 1869. "An outline of the geological evolution of the Eden Valley".  
Proc. Geol. Ass. 11, pp. 258-284.
- GOODCHILD, J.G. 1874. "On Drift".  
Geol. Mag. I, pp. 1-15.
- GOODCHILD, J.G. 1875. "The glacial phenomena of the Eden Valley".  
Quart. Journ. Geol. Soc. 31, pp.55-59.
- GOODING, A.M. and GAMBLE, E. 1960. "Leached, clay-enriched zones in post-Sangamon drift in south-western Ohio and south-eastern Ohio: new observations and data".  
Bul. Geol. Soc. Am. 71, pp.511-514.

- GOODING, A.M., THORPE, J. and GAMBLE, E. 1959. "Leached, clay-enriched zones in post-Sangamonian drift in south-western Ohio and south-eastern Indiana".  
Bull. Geol. Soc. Am. 70, pp.921-925.
- GOODYEAR, R. 1962. "X-ray examination of some east Yorkshire boulder clays".  
Clay Minerals Bulletin, 5, pp.43-44.
- GOODYEAR, J. and DUFFIN, W.J. 1954. "Identification of plagioclase feldspars by X-ray powder methods".  
Mineralogical Mag. 30, 306-326.
- GRAVENOR, C.P. 1951. "Bedrock source of till in south-western Ontario".  
Am. Journ. Sci. 249, pp.66-71.
- GRAVENOR, C.P. 1954. "Mineralogical and size analysis of weathering zones of Illinoian till in Indiana".  
Am. Journ. Sci. 252, pp.150-171.
- GREGORY, K.J. 1962. "The deglaciation of Eastern Eskdale, Yorkshire".  
Proc. Yorks. Geol. Soc. 33, pp.363-380.
- GREGORY, K.J. 1965. "Pro-glacial Lake Eskdale after sixty years".  
Trans. Inst. Brit. Geogs. 36, pp.149-162.
- GRIFFITHS, J.C. 1939. "The mineralogy of the glacial deposits of the region between the rivers Neath and Towy, South Wales".  
Proc. Geol. Assoc. 50, pp.433-462.
- GRIM, R.E. 1953. "Clay Mineralogy".  
McGraw Hill, New York.
- GRIM, R.E. and JOHNS, W.D. 1954. "Clay mineral sediments in the Gulf of Mexico".  
Clays and Clay Minerals, 2, p.81.
- HOLLINGWORTH, S.E. 1938. "The recognition and correlation of high level erosion surfaces in Britain: a statistical study".  
Quart. Journ. Geol. Soc. 94, pp:55-84.
- HOLMES, C.D. 1941. "Till Fabric".  
Bull. Geol. Soc. Am. 52, pp.1299-1354.
- HOLMES, C.D. 1952. "Drift dispersion in west-central New York".  
Bull. Geol. Soc. Am. 63, pp. 993-1010.
- HOLZINGER, K.J. and HARMAN, H.H. 1941. "Factor Analysis".  
Univ. Chicago Press.
- HOPPE, G. 1952. "Hummocky moraine regions with special reference to the interior of Norrbotten".  
Geografiska Annaler 1-2, pp.1-72.

- HOWARTH, R.J. 1967. "Trend-surface fitting to random data - an experimental test."  
Am. Journ. Sci. 265, pp.619-625.
- HOWSE, R. 1864. "On the glaciation of the counties of Durham and Northumberland".  
Trans. N. of England Min. Engs. 13, pp. 169-185.
- HUDSON, R.G.S., VERSEY, H.C., EDWARDS, W. and RAISTRICK, A. 1928.  
"The geology of the country around Harrogate".  
Proc. Geol. Ass. 49, pp.293-352.
- IMBRIE, J. and PURDY, E.G. 1962, "Classification of modern Bahamian carbonate sediments". p.253-272, in: Ham, W.E. (ed),  
Am. Assoc. Petroleum Geologists Mem I, 279p.
- IMBRIE, J. and VAN ANDEL, T.H. 1964. "Vector analysis of heavy mineral data".  
Bull. Geol. Soc. Am. 75, pp.1131-1156.
- INMAN, D.L. 1952. "Measures for describing the size distribution of sediments".  
Journ. Sed. Petrol. 22, pp.125-145.
- JACKSON, M.L. 1962. "Soil Chemical Analysis".  
Constable, London.
- HARBAUGH, J.W. and MERRIAM, D.F. 1968. "Computer Applications in stratigraphic analysis".  
Wiley, New York.
- HARMAN, H.H. 1967. "Modern Factor Analysis". 2nd Ed.  
Univ. Chicago Press. Chicago.
- HARRIS, S.A. 1968. "Till fabrics and speed of movement of the Arapahoe Glacier, Colorado".  
Prof. Geog. 20, pp.195-198.
- HARRISON, P.W. 1957a. "A clay-till fabric - its character and origin".  
Journ. of Geol. 65, pp.273-303.
- HARRISON, P.W. 1957b. "New Technique for three-dimensional fabric analysis of till and englacial debris containing particles from 3-40 mm. in size".  
Journ. of Geol. 65, pp. 98-105.
- HARRISON, P.W. 1960. "Original bedrock composition of Wisconsin till in central Indiana".  
Journ. Sed. Petrol. 30, pp.432-446.
- HARTSHORN, J.H. 1958. "Flow till in south-eastern Massachusetts".  
Bull. Geol. Soc. Am. 69, pp.477-482.
- HERDMAN, T. 1909. "The glacial phenomena of the Vale of Derwent".  
Proc. Univ. Durham. Phil. Soc. 3, pp.109-119.

- HICKLING, H.G.A. 1931. "Contributions to the geology of Northumberland and Durham".  
Proc. Geol. Ass. 42, pp.217-227.
- HOLLINGWORTH, S.E. 1929. "The evolution of the Eden drainage in the south and west".  
Proc. Geol. Ass. 40, pp.115-138.
- HOLLINGWORTH, S.E. 1931. "The glaciation of western Edenside and adjacent areas, and the drumlins of Edenside and the Solway Basin".  
Quart. Journ. Geol. Soc. 87, pp.281-359.
- HOLLINGWORTH, S.E. 1932. in Trotter, F.M. and Hollingworth, S.E.  
"The Geology of the Brampton District".  
Memoir of Geol. Survey, England and Wales.
- JACKSON, M.L. 1964. "Soil clay mineralogical analysis".  
In: RICH, C.I. and KUNZE, G.W. (Eds) Soil Clay Mineralogy,  
a symposium, Durham.
- JARNEFORS, B. 1952. "A sedimentpetrographic study of glacial till from the Pajala district, North Sweden".  
Geol. Foren. Stockholm. Forhand. 74, pp.185-211.
- JEFFERY, G.B. 1922. "The motion of ellipsoid particles immersed in a viscous fluid".  
Royal Soc. London, Proc. Ser. A. 102, p.161.
- JOHNSON, G.A.L. 1963. "The Geology of Moor House".  
H.M.S.O. London.
- JOHNSON, G.A.L., HODGE, B.L. and FARIBAIRNE, R.A. 1962. "The base of the Namurian and of the Millstone Grit in north-east England".  
Proc. Yorks. Geol. Soc. 33, pp.341-362.
- KAISER, R.F. 1962. "Composition and origin of glacial till, Mexico and Kasoag quadranges, New York".  
Journ. Sed. Petrol. 32, pp.502-513.
- KARLSTROM, N.V. 1952. "Improved equipment and techniques for orientation studies of large particles in sediments".  
Journ. of Geol. 60, pp.489-493.
- KAURANNE, L.K. 1960. "A statistical study of stone orientation in glacial till".  
Bull. Comm. Geol. Finlande No.188.



- KELLY, T.E. and BAKER, C.H. "Colour variations within glacial till, north Dakota".  
Journ. Sed.Petrol. 36.
- KENDALL, P.F. 1902. "A system of glacial lakes in the Cleveland Hills".  
Quart. Journ. Geol. Soc. 58, pp.471-569.
- KING, C.A.M. 1966. "Techniques in Geomorphology".  
Arnold, London.
- KING, C.A.M. 1967. "An introduction to Trend Surface Analysis".  
Bull, Quant. data for Geographers No. 12.
- KIRBY, R.P. 1961. "Movements of ice in central Labrador-Ungava".  
Cahiers Geog. Quebec. 10, pp 205-219.
- KLOVAN, J.E. 1968. "Q-mode factor analysis program in fortran IV for small computers".  
Kansas Geol. Survey Sp. Dist. Pbl. 20, pp.39-51.
- KNOX, K.S. 1953. "The differentiation of the glacial tills of the north shore of Lake Erie".  
Mineralogical Journal of Canada 74, p.106.
- KRUGER, F.C. 1937. "A sedimentary and petrographic study of certain glacial drifts of Minnesota".  
Am. Journ. Sci. 34, pp.345-363.
- KRUMBEIN, W.C. 1933. "Textural and lithological variations in glacial till".  
Journ. of Geol. 41, pp.383-408.
- KRUMBEIN, W.C. 1934. "Size frequency distribution of sediments".  
Journ. Sed. Petrol. 4, pp.65-74.
- KRUMBEIN, W.C. 1937. "Sediments and exponential curves".  
Journ. of Geol. 45, pp.577-601.
- KRUMBEIN, W.C. 1939. "Preferred orientation of pebbles in sedimentary deposits".  
Journ. of Geol. 47, 672-706.pp.
- KRUMBEIN, W.C. 1963. "Confidence intervals on low order polynomial trend surfaces".  
Journ. Geophys. Res. 68, pp.5869-5878.
- KRUMBEIN, W.C. and GRAYBILL, F.A. 1965. "An introduction to statistical models in geology".  
McGraw-Hill, New York.
- KRUMBEIN, W.C. and PETTIJOHN, F.J. 1938. "Manual of Sedimentary Petrology".  
D.Appleton-Century Co. New York.
- KRYNINE, P.D. 1937. "Glacial sedimentology of the Qunnipiac-Pequabuck lowland in southern Connecticut".  
Am. Journ. Sci. 33 pp. 111-139.

- KUENEN, P.H. 1951. "Mechanics of varve formation and the Action of turbidity currents".  
Geol. For. Stockh. Forh. 6, pp.149-162.
- LAG, J. 1948. "Undersokelser over opphavsmaterialet for Østlandets morenedekker".  
Det Norske Skogforsoksvesen No. 35, 223p.
- LEBOUR, G.A. 1894. "On certain features of the glacial deposits of the Tyne Valley".  
Trans. Nat. Hist. Soc. Northumb. Durham. II, pp.191-195.
- LEIGHTON, M.M. and MACLINTOCK, P. 1930. "Weathered zones of drift sheets of Illinois".  
Journ. of Geol. 38, pp.28-53.
- LINTON, D.L. 1951. "Problems of Scottish Scenery".  
Scottish Geog. Mag. 67, pp.65-85.
- LEWIS, F.J. 1904. "Interglacial and post-glacial beds of the Cross Fell district".  
Rep. Brit. Ass. pp.798-799.
- LUNDQVIST, G. 1935. "Blockundersokningar. Historik ock metodik".  
Sverges Geol. Undersokning 390.
- LUNDQVIST, G. 1940. "Bergslagens minerogena jordarter".  
Sverges Geol. Undersokning, 433.
- LUNDQVIST, G. 1948. "Blockens orientering i olika jordarter".  
Sverges Geol. Undersokning 497, pp. 1-29.
- LUNDQVIST, J. 1958. "Beskrivning till jordartskarta Över Varmlands län".  
Sveriges Geol. Undersokning. 38, pp. 1-229.
- MCCAMMON, R.B. 1962. "Efficiencies of percentile measures for describing the mean size and sorting of sedimentary particles".  
Journ. of Geol. 70, pp.453-465.
- MACLINTOCK, P. 1933. "Correlation of the pre-Illinois drifts of Illinois".  
Journ. of Geol. 41, pp.710-722.
- MACLINTOCK, P. and DREIMANIS, A. 1964. "Reorientation of till fabric by overriding glacier in the St. Lawrence Valley".  
Am. Journ. Sci. 262, pp.133-142.
- MALING, D.H. 1955. "The Geomorphology of the Wear Valley".  
University of Durham, Ph.D. Thesis.
- MANNERFELT, C.M. 1945. "Nagra glacialmorfologiska formelement".  
Geogr. Annaler 27, pp.1-239.

- MANNERFELT, C.M. 1949. "Marginal drainage channels as indicators of the gradients of Quaternary ice-caps".  
Geogr. Annaler 31, pp. 194-199.
- MANLEY, G. 1936. "The Climate of the Northern Pennines: the coldest part of England".  
Quart. Journ. Roy. Met. Soc. 62, pp.103-115.
- MANLEY, G. 1955. "On the occurrence of ice-domes and permanently snow-covered summits".  
Journ. of Glaciology, 2, pp.453-456.
- MANLEY, G. 1959. "The late-glacial climate of N.W.England".  
Liverpool and Manchester Geol. Journ. 2, pp.188-215.
- MARR, J.E. 1921. "The rigidity of north-west Yorkshire".  
Naturalist, pp. 63-72.
- MASON, C.C. and FOLK, R.L. 1958. "Differentiation of beach, dune and aeolian flat environments by size analysis, Mustang Island, Texas".  
Journ. Sed. Petrol. 28, pp.211-226.
- MERRICK, E. 1915. "On the formation of the River Tyne drainage area".  
Geol. Mag. 52, pp.194-304, 353-360.
- MERRIT, R.S. and MULLER, E.H. 1959. "Depths of leaching in relation to carbonate content of the till in central New York State".  
Am. Journ. Sci. 257, pp.465-480.
- MILLER, H. 1850. "On peculiar scratched pebbles, etc. in the boulder clay of Caithness".  
Rep. Brit. Ass. 1850. pp.93-96.
- MILLER, H. 1884. "On boulder glaciation".  
Proc. Roy. Soc. Edin. 8, pp.156-189.
- MIINER, H.B. 1940. "Sedimentary Petrology" 3rd Ed.  
Allen and Unwin, London.
- MITCHELL, B.D. and MITCHELL, W.A. 1956. "The clay mineralogy of Ayrshire soils and their parent materials".  
Clay Minerals Bull. 3, pp.91-97.
- MOORBATH, S. and DODSON, M.H. 1961. "Isotopic ages of the Weardale Granite".  
Nature 90, p.900.
- MOSS, A.J. 1962. "The physical nature of common sandy and pebbly deposits. Part I".  
Am. Journ. Sci. 260, pp.337-372.
- MOSS, A.J. 1962b. "The physical nature of common sandy and pebbly deposits. Part 2".  
Am. Journ. Sci. 261, pp.297-343.

- MULLER, G. 1967. "Methods in Sedimentary Petrology".  
Hafner Publ. Co. New York and London.
- NIEMIAROWSKI, W., 1963. "Some problems concerning deglaciation by stagnation and wastage of large portions of the ice-sheet within the area of the last glaciation in Poland".  
Rep. 6th Conf. Int. Ass. Quat. Res. (Warsaw, 1961) Lodz (1963), 3, pp.245-56.
- NORCLIFFE, G.B. 1969. "On the use and limitation of trend surface models".  
Paper presented to the Institute of British Geographers (Quantitative sub-group) at Cambridge.
- O'LEARY, M., LIPPERT, R.H. and SPITZ, O.T. 1966. "Fortran IV and map program for computation and plotting of trend surfaces for degrees 1 through 6."  
Kansas Geol. Survey Computer Contrib. No. 3.
- OKKO, V. 1945. "Untersuchungen uber den Mikkeli-Os".  
Fennia 69, no. 1.
- OKKO, V. 1941. "Uber das Verhaltnis der Gesteinszusammensetzung der morane sum Felsgrund in den Gebieten der Kartenblatter von Ylitorino und Rovaniemi im nordlichen Finnland".  
Geol. Rundschau, 32, p.627-643.
- OKKO, V. 1955. "Glacial drift in Iceland".  
Comm. Geol. Sur. Finlande Bull. 170, pp.1-133.
- PEEL, R.F. 1949. "A study of two Northumbrian Spillways".  
Trans. Inst. Brit. Geog. 15, pp.73-89.
- PEEL, R.F. 1956. "The profiles of glacial drainage channels".  
Geogr. Journ. 122, pp.483-487.
- PEEL, R.F. 1966. "Some Geomorphological aspects of the Tyne drainage system".  
In: Northern Geographical Essay (ed. House, J.W.). Oriel Press, Newcastle.
- PENNY, L.F. and CATT, J.A. 1967. "Stone orientations and other structural features of the tills of East Yorkshire".  
Geol. Mag. 104, pp.344-360.
- PERRIN, R.M.S. 1956. "The clay mineralogy of some tills in the Cambridge District".  
Clay Minerals Bull. 3, pp.193-197.
- PHILLIPS, J. 1836. "Illustrations of the Geology of Yorkshire. Part II, The Mountain Limestone District".  
London.
- PIPER, C.F. 1942. "Soil and Plant Analysis".  
Waite Agricultural Institute, Adelaide.

- POTTER, P.E. and PETTIJOHN, F.J. 1963. "Palaeocurrents and basin analysis". Springer-Verlag, Berlin.
- PRICE, R.J. 1960. "Glacial meltwater channels in the Upper Tweed drainage basin". Geogr. Journ. 126, pp.483-489.
- PRICE, R.J. 1963. "A glacier meltwater drainage system in Peebleshire, Scotland". Scottish Geog. Mag. 79, pp.133-141.
- QUAKERNAAT, J. 1968. "X-ray analysis of clay mineral in some recent fluvial sediments along the coasts of central Italy". Publicaties van het Fysisch-Geografisch Laboratorium, Univeriteit Amsterdam, 12.
- RAISTRICK, A. 1929. "The petrology of some Yorkshire Boulder clays". Geol. Mag. 66, pp.337-344.
- RAISTRICK, A. 1931. "The glaciation of Northumberland and Durham". Proc. Geol. Ass. 42, pp.281-291.
- RAISTRICK, A. and BLACKBURN, K.B. 1932. "Late-glacial and post-glacial periods in the northern Pennines". Trans. Northern Nat. Union I, pp. 16-29.
- REICHE, P. 1938. "An analysis of cross laminations: the Coconini sandstone". Journ. of Geol. 46, pp.905-932.
- RICHTER, K. 1932. "Die Bewegungsrichtung des Inlandeises, rekonstruiert aus den Krtizen und Langsachen der Geschiebe". Zeitschrift Geschiebeforschung, 8, pp.62-66.
- RUSSELL, I.C. 1893. "Malaspina Glacier". Journ. of Geol. I, pp.217-245.
- RUSSELL, E.W. 1958. "Soil Conditions and Plant Growth". Longmans, London.
- SCHYTT, V. 1963. "A tunnel along the bottom of Isfallsgaciaren". Geogr. Annaler. 44, pp.411-412.
- SEARLE, P.L. 1968. "The boulder clays and associated soils of Northumberland Coastal Plain". University of Newcastle, Ph.D. Thesis.
- SHEPPS, V.C. 1953. "Correlations of the tills of north-eastern Ohio by size analysis". Journ. Sed.Petrol. 23, pp.34-38.

- SHEPPS, V.C. 1958. "Size Factors" - a means of analysis of data from textural studies of till.  
Journ. Sed. Petrol. 28, pp.482-485.
- SIEGAL, S. 1956. "Nonparametric statistics for the Behavioural Sciences".  
McGraw Hill, New York.
- SIMPSON, I.M. 1960. "Stone counts in the Pleistocene of the Manchester area".  
Proc. Yorks. Geol. Soc. 32, pp.379-389.
- SISSONS, J.B. 1958a. "Subglacial stream erosion in Southern Northumberland".  
Scottish Geog. Mag. 74, pp.163-174.
- SISSONS, J.B. 1958b. "Supposed ice-dammed lakes in Britain with particular reference of the Eddlestone valley, southern Scotland".  
Geogr. Annaler 40, pp.159-187.
- SISSONS, J.B. 1960a. "Erosion surfaces, cyclic slopes and drainage systems in southern Scotland and northern England".  
Trans. Inst. Brit. Geog. 28, pp.23-38.
- SISSONS, J.B. 1960b. "Some aspects of glacial drainage channels in Britain. Part I".  
Scottish Geogr. Mag. 76.pp. 131-146.
- SISSONS, J.B. 1961. "Some aspects of glacial drainage channels in Britain. Part 2".  
Scottish Geog. Mag. 77, pp.15-36.
- SMAILES, A.E. 1960. "North England".  
Nelson, London and Edinburgh.
- SMITH, D.B. and FRANCIS, E.A. 1967. "The geology of the country between Durham and West Hartlepool".  
Mem. Geol. Survey. England and Wales.
- SMYTHE, J.A. 1912. "Glacial geology of Northumberland".  
Trans. Nat. Hist. Soc. Northum. and Durham, 4, pp.86-116.
- SPEARS, D.A. 1961. "Joints in the Whin Sill and associated sediments in Upper Teesdale, northern Pennines".  
Proc. Yorks. Geol. Soc. 33, pp.21-30.
- SPENCER, D.W. 1963. "The interpretation of grain size distribution curves of clastic sediments".  
Journ. Sed. Petrol. 33, pp.180-190.
- SPEARMAN, C. 1904. "General intelligence, objectively determined and measured".  
Am. Journ. Psychology, 15, pp.201-293.
- STRAW, A. 1957. "Some glacial features of east Lincolnshire".  
East Midland Geog. 1, pp.41-48.

- TARR, R.S. 1897. "The margin of the Cornell Glacier".  
Am. Geol. 20, pp.139-156.
- TARR, R.S. 1908. "Some phenomena of the glacier margins in the Yakutat Bay region, Alaska".  
Z. Gletscherk. 3, pp.81-110.
- TARR, R.S. 1909. "The Yakutat Bay region, Alaska: Physiography and glacial geology".  
U.S. geol. Surv. Prof. Pap. 64.
- THOMAS, G.S.P. 1968. "Routine sediment analysis - a package of three programs".  
Brit. Geomorph. Res. Group Occ. Paper No. 6, pp.29-51.
- THOMAS, H.H. 1909. "A contribution to the petrography of the New Red Sandstone in the west of England".  
Quart. Journ. Geol. Soc. 65, p.239.
- THORNBURY, W.D. 1940. "Weathered zone and glacial chronology in southern Indiana".  
Journ. of Geol. 48, pp.449-476.
- THURSTONE, L.L. 1931. "Multiple factor analysis".  
Psych. Rev. 38, pp.406-427.
- THURSTONE, L.L. 1947. "Multiple factor analysis".  
Univ. Chicago Press, Chicago.
- TINKLER, K.J. 1969. "Trend surfaces with low 'explanations'; the assessment of their reliability".  
Am. Journ. Sci. 267, pp.114-123.
- TRECHMANN, C.T. 1915. "Scandinavian drift in the Durham Coast".  
Quart. Journ. Geol. Soc. 71, pp.53-82.
- TROTTER, F.M. 1929a. "The glaciation of eastern Edenside, the Alston Block and the Carlisle Plain".  
Quart. Journ. Geol. Soc. 85, pp.549-612.
- TROTTER, F.M. 1929b. "The tertiary uplift and resultant drainage of the Alston Block and adjacent areas".  
Proc. Yorks. Geol. Soc. 21, pp.161-180.
- TROTTER, F.M. and HOLLINGWORTH, S.E. 1928a. "Correlation of the northern drifts".  
Geol. Mag. 65, pp.433-448.
- TROTTER, F.M. and HOLLINGWORTH, S.E. 1928b. "The Alston Block".  
Geol. Mag. 65, pp.433-448.
- TROTTER, F.M. and HOLLINGWORTH, S.E. 1932a. "The Geology of the Brampton District". Memoirs of Geol. Survey, England and Wales.

- TROTTER, F.M. and HOLLINGWORTH, S.E. 1932b. "The glacial sequence of the north of England".  
Geol. Mag. 69, pp.374-380.
- TWENHOFEL, W.H. 1932. "Treatise on Sedimentation".  
Williams and Wilkins, Baltimore.
- TWIDALE, C.R. 1956. "Glacial overflow channels in north Lincolnshire".  
Trans. Inst. Brit. Geogr. 22, pp.47-54.
- UDDEN, J.A. 1898. "The mechanical composition of wind deposits".  
Augustana Library Publ.I.
- UDDEN, J.A. 1914. "Mechanical composition of clastic sediments".  
Bull. Geol. Soc. Am. 25, pp.377-392.
- USSING, N.V. and MADSEN, V. 1897. "Kortbladet Hindsholm".  
Danmarks Geol. Undersoglse. I, no.2.
- VAN HOUTEN, F.B. 1961. "Climatic Significance of Red Beds".  
pp.89-140. in: Descriptive Palaeoclimatology (ed. Nairn)  
Interscience, New York and London.
- VERSEY, H.C. 1960. "Geology of the Appleby District".  
Whitehead and Sons, Leeds.
- VIRKKALA, K. 1951. "Glacial geology of the Suomussalmi area, east Finland".  
Comm. Geol. Finlande Bull. 155, pp. 1-66.
- VON ENGELN, O.D. 1911. "Phenomena associated with glacier drainage and wastage, with especial reference to observations in the Yakutat Bay region, Alaska".  
Z. Gletscherk, 6, pp.104-150.
- WEAVER, C.E. 1956. "The distribution and identification of mixed-layer clays in sedimentary rocks".  
American Mineralogist 41, pp.202-222.
- WEST, R.G. and DONNER, J.J. 1956. "The glaciation of East Anglia and the Midlands. A differentiation based on stone orientation measurements of the tills".  
Quart. Journ. Geol. Soc. 122, pp.69-91.
- WHITE, G.W. and SHEPPS, V.C. 1952. "Characteristics of Wisconsin tills in north-east Ohio".  
Bull. Geol. Soc. Am. 63, pp.1388.
- WILLMAN, H.B., GLASS, H.D. and FRYE, J.C. 1963. "Mineralogy of glacial tills".  
Illinois State Geol. Survey circ. 347.
- WOOLACOTT, D. 1920. "On an exposure of sands and gravels containing marine shells at Easington, Durham".  
Geol. Mag. 57, pp.307-311.



- WOOLACOTT, D. 1921. "The interglacial problem and the glacial and post glacial sequence in Northumberland and Durham".  
Geol. Mag. 58, pp. 26-27, 60-69.
- WOOLACOTT, D. 1923. "A boring at Roddymoor Colliery near Crook, Co. Durham".  
Geol. Mag. 60, p.50.
- WOOLDRIDGE, S.W. 1950. "The Upland Plains of Britain".  
Adv. Science. 7, pp.162-172.
- WRIGHT, H.E. 1957. "Stone orientation in the Wadena Drumlin field, Minnesota".  
Geogr. Annaler, 39, pp.19-31.
- WRIGHT, R.L. 1955. "An investigation into the denudation chronology of parts of Teesdale and Weardale".  
Sheffield University, M.Sc. thesis.

APPENDICES.

Appendix I.

Place Names in the Study Area mentioned in the Text.

Map references of Ordnance Survey Sheets 76, 77, 83 and 84 (One inch map of Great Britain.)

Acton Burn	830513	Cross Fell	688344
Allendale Cemetery	832556	Cupola	800587
Allendale Common	820506	Dewsgreen Burn	770573
Allendale Scar	838562	Dingbell Hill	776586
Allenheads	860454	Dirt Pot	852462
Alston	718465	Ellershope Bridge	852488
Ashes	782538	Eshells Moor	870575
Ayle Burn	715490	Gelt Burn	634503
Barhaugh Burn	700520	Gilderdale	680460
Bearsbridge	779578	Glencune Burn	664620
Beldon Clough	913505	Glendue Burn	667566
Bellister Castle	700630	Glendue Wood	676566
Bishop Field	828565	Great Blacklaw Hill	622534
Bishopside	806583	Great Heaplaw	686487
Black Burn	628580	Grey Nag	665476
Black Fell	648445	Harbut Lodge	713473
Blaeberry Burn	760557	Harper Town	673585
Bull's Hill	850562	Hartside Height	650426
Butt Hill	627503	Hawksteel	809555
Carr's Burn	755543	High Shield	648480
Chapel House	819569	Kiddygreen	809575
Church Burn	785587	Killhope Moor	820447
Clargillhead	736495	Knarsdale	679540
Coanwood Common	720574	Knar Burn	660515
Cold Fell	606557	Knockburn	839509
Coldacre Hill	686508	Knock Shield	837507

Knock Shield Burn	830500	Thornley Gate	832662
Know Head	684555	Turney Shield	799490
Linn Burn	882525	Wellhope Burn	775490
Lintley	688512	White Walls	778522
Little Heaplaw	688491	Whitewalls Burn	760520
Mohope Burn	761490	Whitfield	779583
New Water	590510	Whitfield Hall	779558
Newshield Moss	732485	Witchell Moss	748582
Ninebanks	782539	Wooley Park	834554
Old Water	590532		
Ouston Fell	755510		
Parkgates	846542		
Parsons Shield	648532		
Peasmeadows	852471		
Pia Troon	826571		
Riding Hill	827568		
Sandyford Sike	805575		
Sinderhope	843522		
Sipton Shield	845499		
Sipton Clough	852500		
Slaggyford	678525		
Slate Hill	800435		
Shope Burn	690550		
Softley	678555		
Spartylea	850490		
Studdon	839538		
Swinhope Burn	830470		
Tarry Back	785578		
Thinhope Burn	646536		
Thornhope Burn	679497		

## Appendix 2.

### Particle Size Analysis.

#### a. Coarse Analysis.

##### Equipment.

1. British standard sieves as follows:-  $\frac{3}{4}$  in.,  $\frac{1}{2}$  in.,  $\frac{3}{8}$  in.,  $\frac{1}{4}$  in.,  $\frac{3}{16}$  in.,  $\frac{1}{8}$  in., nos. 8, 14, 25, 36, 52, 72, 100, 150, 200 240 and a receiver.
2. Balance readable to 0.001 gram.
3. Thermostatically controlled oven capable of maintaining a temperature of 105 to 110 degrees C.
4. Evaporating dishes c.6 inches in diameter.
5. Metal trays or similar.
6. Sieve brush.
7. Sodium hexametaphosphate (Calgon).
8. Mechanical sieve shaker.
9. Riffle.
10. Large wide necked bottles with capacities of c.2 litres.

##### Procedure.

The sediment for testing shall be dried at 105 to 100 degrees C. for 24 hours. From this sample a sample of 2000 grams shall be obtained by riffling.

This sample shall be divided into four and each sub-sample placed in a wide necked bottle. A solution of sodium hexametaphosphate shall be added (c.20 ml.) and the sample topped up to 2 litres with distilled water. The soil and water mixture shall be stirred and allowed to stand overnight to aid dispersion.

The suspension shall be washed through a No. 8 and 240 sieve, and the finer material allowed to run to waste. Care must be taken not to overload the no. 240 sieve and it may be necessary to carry out this stage of the analysis in several stages if overloading occurs.

The washing process shall continue until the water passing the No. 240 sieve is substantially clear. The material remaining on the sieves shall be carefully washed into the evaporating dish and allowed to dry. When dry the material shall be weighed and dry sieved, using a full range of sieves stacked on a mechanical shaker.

The percentage weight of material on each sieve shall be calculated. The percentage weight of material passing the No. 240 sieve shall be obtained by difference. The cumulative percentage (by weight of the total sample) passing each sieve shall be calculated.

b. Fine Analysis by the Pipette Method.

Scope.

This method covers the quantitative determination of the particle size distribution in a sediment from the coarse sand size down.

Equipment.

1. A suitable pipette fitted with a pressure and suction inlet, and having a capacity of approximately 10 ml. It shall be so arranged that it can be inserted to a fixed depth into a sedimentation tube when the latter is immersed in a constant temperature bath.
2. Six glass sedimentation tubes, 5 cm. in diameter and approximately 34 cm. long graduated at 500 ml. volume, with rubber bungs to fit.
3. 42 (seven for each sediment sample) glass weighing bottles, approximately 25 mm. in diameter and 50 mm. high. The weights of the bottles shall be known to the nearest 0.001 gram.
4. A constant temperature bath capable of being maintained at 25° C into which the sedimentation tubes can be immersed up to the 500 ml. mark. The bath shall not vibrate the sample.
5. A suitable mechanical mixer.
6. A balance readable and accurate to 0.001 gram.
7. A thermostatically controlled drying oven, capable of maintaining a temperature of 105 - 110°C.
8. A stop clock.

9. 6 x 6 inch diameter evaporating dishes.
10. A Buchner funnel about 10 cm. in diameter.
11. 1 x 1 litre conical beaker.
12. A filter flask to take the Buchner funnel (about 500 ml.).
13. 1 x 1 100 ml. measuring cylinder.
14. A wash bottle preferably plastic containing distilled water.
15. Filter papers to fit the Buchner funnel.
16. Litmus paper (blue).
17. A length of glass rod about 6-8 inches long and fitted at one end with a rubber policeman.
18. A source of vacuum, e.g. an efficient filter pump.
19. A length of rubber tubing to fit vacuum pump and filter flask.

#### Reagents.

The reagents used shall be of recognised analytical reagent quality.

1. Hydrogen peroxide. A 20 volume solution.
2. Hydrochloric acid N solution.
3. Sodium hexametaphosphate solution.

#### Calibration of sampling pipette.

The sampling pipette shall be thoroughly cleaned and dried and the nozzle shall be immersed in distilled water. The tap B shall be closed and the tap E opened.

By means of a rubber tube attached to C, water shall be sucked up into the pipette until it rises above E. The tap E shall be closed, and the pipette removed from the water. Surplus water drawn up into the cavity above E shall be poured off through F into a small beaker.

The water contained in the pipette and the tap E shall be discharged into a glass weighing bottle of known weight and the weight determined. From this weight the internal volume ( $V_p$  ml) of the pipette and the tap shall be calculated to the nearest 0.05 ml. Three determinations of the volume shall

be made and the average value taken.

### Procedure

#### Pretreatment of sample.

15 grams of soil shall be weighed to the nearest 0.001 g. ( $W_a$ ) and placed in the 1 litre conical beaker. 50 ml. of distilled water shall be added and the soil suspension shall be gently boiled until the volume is reduced to about 40 ml.

After cooling 75 ml. of hydrogen peroxide shall be added and the mixture allowed to stand overnight. The suspension shall be gently heated. Care must be taken to avoid frothing over and the contents of the beaker shall be agitated frequently. As soon as vigorous frothing has subsided the volume shall be reduced to about 30 ml. by boiling.

In the case of soils containing calcium compounds the mixture shall be allowed to cool and 10 ml. of hydrochloric acid shall be added. The solution shall be stirred with a glass rod for a few minutes and allowed to stand for 1 hour. When the treatment is complete the solution shall have an acid reaction to litmus. The mixture shall be filtered and washed with warm water until the filtrate shows no reaction to litmus.

The damp soil on the filter paper and funnel shall be transferred without any loss whatsoever to the evaporating dish (weighed to 0.01 g.) using a jet of distilled water. The dish and the contents shall be placed in an oven and dried at 105 - 110°C. They shall then be weighed to 0.01 g. and the weight of soil remaining after pretreatment shall be recorded ( $W_b$ ).

#### Dispersion of soil.

25 ml. of the sodium hexametaphosphate solution shall be added from the pipette to the soil in the evaporating dish together with about 25 ml. of distilled water and the soil brought into suspension by stirring with a glass rod. The mixture shall be gently warmed for 10 minutes and then transferred to the mixer container using a jet of distilled water. Any soil adhering to the dish shall be rubbed off with the rubber policeman. The amount of water used shall not exceed 150 ml. The soil suspension shall then be agitated for 15 minutes by means of the mechanical mixer.



The suspension shall be transferred to the sedimentation tube and the volume of liquid made up to 500 ml. with distilled water.

### Sedimentation.

25 ml. of the sodium hexametaphosphate solution shall be transferred from a pipette to a graduated 500 ml. sedimentation tube and diluted with distilled water to exactly 500 ml. This sedimentation tube together with the sedimentation tube containing the soil suspension shall be transferred to a constant temperature bath and a rubber bung inserted in the tube. When they have attained the temperature of the bath the tubes and contents shall be taken out and shall then be thoroughly shaken by inverting several times and shall be replaced in the bath.

At the same instant as the tube containing the soil suspension is replaced in the bath the stop clock shall be started. The rubber bungs shall be removed carefully and placed lightly on the top of each tube.

The pipette with the tap E closed shall be lowered vertically into the soil suspension until the end is  $100^{\pm}$  mm. below the surface of the solution. It shall be lowered with great care some 15 seconds before the sample is due to be taken. Approximately 10 seconds shall be taken to complete this operation.

The tap E shall be opened and a sample ( $V_p$  ml) drawn up into the pipette. The pipette and bore in the tap E shall be filled with the solution and the tap E then closed. This sampling operation shall take 10 seconds to complete. This procedure shall be carried out at the following times: 30 sec., 2 min. 4 sec., 5 min. 43 sec., 12 min. 55 sec., 29 min. 5 sec., 1 hour 56 min., 7 hours 45 min.

During the sampling a small amount of suspension may be drawn up into bulb D above the bore of tap E. This surplus shall be washed away into a beaker down the outlet tube F by opening the tap E in such a way as to connect D and F. Distilled water shall then be allowed to run from the bulb funnel A into D and out through F until no solution remains in the system.

A tared weighing bottle shall be placed under the end of the pipette and the tap E opened so that the contents of the pipette are delivered into the bottle. Any suspension left on the inner walls of the pipette shall be washed

into the weighing bottle by allowing distilled water from bulb A to run through B, D and E into the pipette. The weighing bottle and contents shall be placed in the oven maintained at a temperature of 105-110°C and the sample evaporated to dryness. The bottle and the contents shall be weighed to the nearest 0.001 g. and the weight of the solid material in the sample determined ( $W_1$ ,  $W_2$  and  $W_3$  for each respective sampling time).

Between any of the above sampling times a sample ( $V_p$  ml) shall be taken from the tube containing the sodium hexametaphosphate solution. The weight of the solid material in the sample shall be determined ( $W_4$ ).

### Calculations.

#### Loss in pretreatment.

The percentage loss in pretreatment (P) shall be calculated from the weight of air-dried soil used ( $W_a$ ), and the weight of soil after pretreatment ( $W_b$ ) from the formula:

$$P = 100 - \frac{W_b (100)}{W_a} \quad \text{percent.}$$

The weight of the pretreated soil ( $W_b$ ) shall be used to calculate the percentages below.

#### Sedimentation.

The weights of the solid material in 500 ml. of suspension for each respective sampling time shall be calculated from the formula:

$$M_1 \text{ or } M_2 \text{ or } M_3 \text{ or } M_4 = \frac{W_1 \text{ or } W_2 \text{ or } W_3 \text{ or } W_4}{V_p} \times 500 \text{ g.}$$

where  $M_1$  = weight of material in 500 ml. from first sample  
 $M_2$  = weight of material in 500 ml. from second sample  
 $M_3$  = weight of material in 500 ml. from third sample

$V_p$  = calibrated volume of pipette in ml.

The percentage of each particular particle size in the original sample shall be calculated from the following formula:

$$\frac{M_a}{W_b} \times 100$$

Where  $M_a$  = weight of material in 500 ml. of a particular particle size

$M_b$  = weight of material in 500 ml. of next finest sample taken with pipette.

The percentage of material in the finest grade sampled with the pipette shall be determined from the following formula:

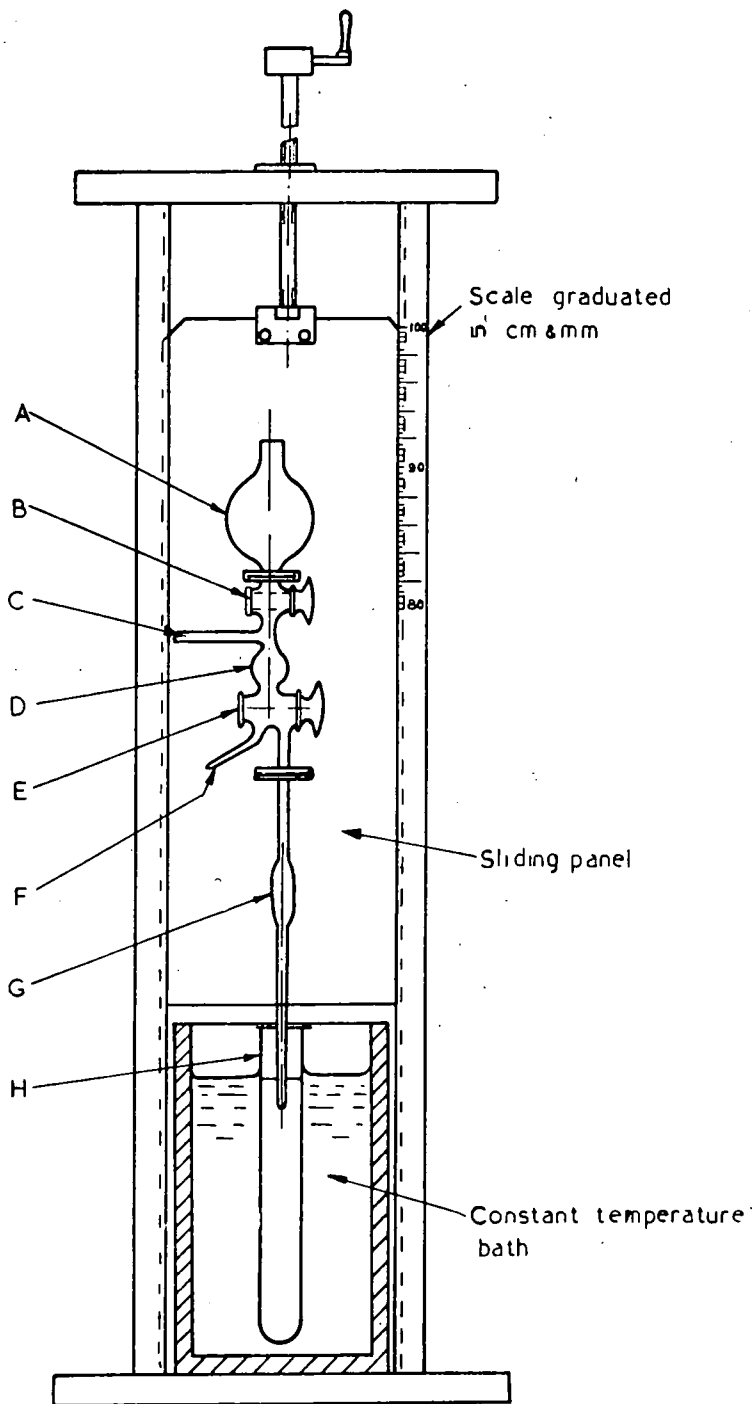
$$\frac{M_c - M_4}{W_b} \times 100$$

Where  $M_c$  is finest grade size measured with pipette.

$M_4$  is the weight of sodium hexametaphosphate in 500 mls. and

$W_b$  weight of pretreated soil.

The percentage obtained shall be expressed as cumulative percentage of the total sample.



A & B. 125 ml bulb funnel with stopcock.

C. Safety bulb suction inlet tube.

D. Safety bulb.

F. Outlet tube.

G. Sampling pipette.

H. Sedimentation tube.

D, F, & G are joined to three-way stopcock E.

**Diagram showing an arrangement for lowering the sampling pipette into the soil suspension**

Appendix 3.

STONE ORIENTATIONS

(Number of stones in each sector)

Orientation sector in degrees	* 1	2	3	4	5	6	7	8	9	10
0 - 10	7	6			6	1	5			9
10 - 20	6	10		1	7		17			6
20 - 30	9	6			4		13			5
30 - 40	8	2	2	1	3		6	2		2
40 - 50	6		10				3	1		1
50 - 60	2		15	1						
60 - 70	4		10	6						
70 - 80	1		10	7						
80 - 90			3	15						2
90 -100				11				3	4	
100 -110	1			5		8		6	6	
110 -120				1		11		7	8	
120 -130						13		6	6	5
130 -140				1	3	10	3	3	11	2
140 -150				1	7	4		11	4	1
150 -160	2	4			3	2	2	4	5	6
160 -170	1	12			11	2	1	5	3	6
170 -180	4	10			6			2	1	7
Total no. of stones	51	50	50	50	50	50	50	50	50	50

\* The location of each orientation is indicated on fig. 6.2.

Appendix 3 cont.

Orientation sector in degrees.	11	12	13	14	15	16	17	18	19	20
0 - 10	6	6		14	10	9	1	1	2	3
10 - 20	10	4		3	7	7	2	4		3
20 - 30	8	2		1	4	2	1	1		3
30 - 40	7			1	3	2	1			2
40 - 50	1				1	2	6	5	1	2
50 - 60	3						4	4		6
60 - 70	1						4	3		10
70 - 80	2				2		13	6		6
80 - 90	1	1			1		4	7	3	5
90 -100		1	8			1	5	3	4	3
100 -110			7	1		1	5	2	3	1
110 -120	2		3	1		2	1	2	4	
120 -130		3	10			1	2	2	7	
130 -140		5	15		2	3		3	10	
140 -150		6	5	1	1	4		5	6	3
150 -160		7	2	2	1	3		1	3	2
160 -170	6	11		9	7	6		1	2	
170 -180	3	4		17	11	7	1			1
Total no. of stones	50	50	50	50	50	50	50	50	50	50

Appendix 3 cont.

Orientation sector in degrees	21	22	23	24	25	26	27	28	29	30
0 - 10	4		7	2	12	9	3			1
10 - 20	3		3	3	11	6	10	2		2
20 - 30	4		5	1	10	3	5	13		2
30 - 40	5		1	1	9	5	5	14	2	
40 - 50	2		1	3	2	5	2	10		
50 - 60	6		1	2		3	3	6	3	1
60 - 70	9					2		3	1	
70 - 80	5			4	1	4		1	1	1
80 - 90	2			5		2	2	1	2	
90 -100		1		11		4			3	1
100 -110	2	1	1	7		2			14	2
110 -120		4		4					10	3
120 -130		9		2			1		3	8
130 -140		8		1			1		7	11
140 -150	2	8	4	2			5		1	11
150 -160	2	7	6			1	3		2	5
160 -170	1	3	9	1	2	1	7		1	2
170 -180	3	5	11	1	3	3	3			
Total no. of stones	50	50	50	50	50	50	50	50	50	50

## Appendix 4.

### Calcium Carbonate Content (After Piper 1942)

#### Equipment.

1. Balance readable to 0.01 grams.
2. 6 x 100 mls. beakers.
3. 1 x 25 mls. burette.
4. 1 x 100 mls. burette.
5. 1 x 20 mls. pipette.
6. 1 x 1 ml. pipette.
7. 6 x 50 mls. Erlenmayer flask.

#### Solutions.

1. N HCL
2. N NaOH
3. Bromo-thymol blue indicator solution.

#### Procedure.

5 grams of air dried soil (material passing the No. 8 mesh sieve) shall be weighed into a tall 100 mls. beaker.

100 mls. of 1 N HCL shall be run from a burette into the beaker and the mixture stirred. The beaker shall be left to stand for a period of 8 hours until the liquid becomes clear.

20 mls. of the supernatant liquid shall be pipetted into an Erlenmayer flask, and 10 drops of Bromo-thymol blue indicator solution shall be added.

The solution shall be titrated against the 1 N NaOH until the liquid changes to a bluish colour. For standardisation purposes 2 to 4 blank determinations shall be carried out to determine the titre of the hydrochloric acid.

The percentage of calcium carbonate is given by the equation

$$\% \text{CaCO}_3 = (\text{Blank titration} - \text{actual titration}) \times 5.$$

To ensure accuracy two sub-samples of each sample shall be analysed for  $\text{CaCO}_3$  content and the result expressed as an average of the two values.



## Appendix 5.

### Determination of Ferric Iron Content.

#### Equipment.

1. 6 glass test tubes.
2. 6 glass funnels.
3. Whatmans No. 50 filter paper.
4. Bunsen burner.
5. Water bath.
6. 6 x 100 ml. measuring cylinder.
7. 6 x 10 ml. measuring cylinder.
8. 1 x 1 m. pipette.
9. Eel 'spectra' colorimeter (wavelength 520 mu).
10. Glass dropper.

#### Solutions.

1. Citric acid (20% w/v).
2. Thioglycollic acid.
3. Ammonia (1:3.3 v/v).
4. Distilled water.
5. Concentrated HCl.
6. Concentrated  $\text{HNO}_3$ .
7. Standard Iron solutions containing 5, 10, 15, 20 and 25 ppm.

#### Procedure.

1 gram of dry sample (passing the No. 8 sieve) shall be placed in a glass test tube and 10 ml. of concentrated HCl and a few drops of concentrated  $\text{HNO}_3$  added. The test tube shall be placed in a water bath of boiling water for thirty minutes during which time the sample shall be stirred frequently.

The sample shall be filtered into a 100 ml. measuring cylinder, and the remaining residue in the test tube shall be washed onto the filter paper using a jet of distilled water.

The filtrate shall be diluted to 100 ml. with distilled water.

1 ml. of this solution shall be pipetted into a 10 ml. measuring cylinder to which are successively added, with mixing after each addition:

Citric acid	0.5 ml.
Thioglycollic acid	1 drop.
Ammonia	1 ml.
Distilled water to	10 ml.

The coloured solution shall be passed through an Eel spectra colorimeter and the deflection of the galvanometer shall be recorded. Each of the standard iron solutions shall be treated in a similar manner and the resulting coloured liquid passed through the colorimeter.

Calculations.

The deflections of the colorimeter for each of the iron standards shall be plotted as a curve on graph paper. The total amount of iron, in ppm, contained in the treated sample shall be read off the curve.

i. The value (in ppm) obtained from the calibration curve shall be converted to mg. Iron/ml. (100 ppm = .0001 mg./ml).

ii. The value obtained shall be multiplied by 100 (to allow for an initial dilution). The result indicates the amount of Iron in 1 gram of soil.

iii. The amount of iron in one gram of soil shall be multiplied by 100 to obtain an answer in grams of iron/100 grams of soil.

iv. This value shall be converted into the percent of ferric iron in the sample by multiplying by the following:

$$\frac{\text{Molecular wt. Fe}_2\text{O}_3 \text{ (160)}}{\text{Atomic wt. Fe. (56)}}$$

The result obtained indicates the percentage of ferric iron in the sediment sample.

## Appendix 6.

### Determination of coal content. (After Beaumont 1967).

#### Equipment.

1. A three inch sieve. Mesh No. 300.
2. A balance readable to 0.001 grams.
3. Six inch diameter evaporating dishes.
4. A centrifuge capable of holding 4 x 50 mls. centrifuge tubes.
5. 50 mls. centrifuge tubes.
6. 1 x 250 mls. measuring cylinder.
7. Heating unit.
8. Drying oven.
9. Buckner funnel, vacuum flask and vacuum pump.
10. Whatmans No. 50, filter paper.

#### Solutions.

1. Dispersing agent. Sodium hexametaphosphate.
2. Carbon tetrachloride.

#### Procedure.

50 grams of till sample (passing the No. 8 sieve) shall be weighed into a 6 inch evaporating dish, and 200 mls. of the dispersing agent solution shall be added. The evaporating dish and contents shall be warmed and stirred for thirty minutes.

The suspension in the evaporating dish shall be wet sieved through the No. 300 sieve.

The sand and the coarse fraction retained upon the sieve shall be placed in a drying oven, and the water evaporated. When dry the sand and the silt fraction shall be removed from the evaporating dish and weighed to the nearest 0.001 gram.

The sample of sand and silt shall be riffled and quartered and added to 4 x 50 mls. centrifuge tubes each containing 30 mls. of carbon tetrachloride, and stirred.

The tubes shall be centrifuged at 4000 rpm for 5 minutes, to ensure that the silt particles are removed from suspension.

The tubes shall be removed from the centrifuge, and the floating coal fragments and carbon tetrachloride poured into a Buckner funnel containing a No. 50 filter paper.

The centrifuge tubes shall be topped up with carbon tetrachloride, stirred and re-run to ensure that all the coal fragments are segregated from the sand and silt fraction.

The filter paper containing the coal fragments shall be removed from the Buckner funnel and weighed to the nearest 0.001 gram.

The weight of the coal shall be expressed as a percentage of the original 50 gram sample.

## Appendix 7.

### Preparation of thin sections of laminated clays.

#### Equipment.

1. 6 glass slides (3 inch x 1 inch).
2. Glass plate (c.12 inch x 12 inch).
3. Oven capable of maintaining a temperature of 120°C.
4. 6 screw-top polythene bottles having necks c.3 inches in diameter.
5. Hotplate.
6. 1 x 100 mls. flask.
7. 1 large glass desiccating dish.
8. 1 vacuum pump.
9. 3 feet rubber tubing.
10. 2 tube clamps.

#### Solutions.

1. Araldite resin CY 212 (manufactured by C.I.B.A.).
2. Hardener HY 951 (manufactured by C.I.B.A.).
3. Canada balsam.
4. Acetone.
5. Xylene.

#### Procedure.

A small specimen of clay, c.1½ inches x 1 inch x 1 inch, shall be cut from the field sample. This shall be done as soon as possible after removing the sample from the field exposure (dry samples are impossible to cut). Field samples may be kept damp for a short time if wrapped in polythene.

Samples of rhythmic clays shall not be dried prior to immersion in the cementing medium. (When dry there is a strong tendency for the sample to split).

The damp sample shall be placed in a polythene bottle and covered with xylene. The bottle shall be made airtight and left for two days. The xylene shall be carefully poured away without disturbing the sample.

The following solutions shall be thoroughly mixed in a 100 ml. glass flask:

- |                     |        |
|---------------------|--------|
| i. Resin CY 212     | 50 ml. |
| ii. Hardener HY 951 | 4 ml.  |
| iii. Acetone        | 10 ml. |

The clay sample shall be carefully placed in the desiccator and the impregnating solution shall be gently poured over the sample until it is immersed to a depth of about 1 inch.

Rubber tubing shall be connected to a vacuum pump and also passed into the desiccator via the bung at the top of the dish. A vacuum shall be produced in the desiccator after which the clamps shall be tightened around the rubber tube. The sample shall be left in the desiccator under vacuum for a week.

The sample shall be carefully removed from the desiccator and placed in an oven at a temperature of 120°C for two hours.

A small amount of Canada balsam shall be poured onto a glass slide and heated on the hotplate. The Canada balsam can be judged ready for use when thin strands pulled from the surface of the heated balsam become brittle on cooling.

The clay samples shall be removed from the oven and embedded in the Canada balsam on the glass slide. The sample shall be removed from the hotplate and allowed to cool.

Carborundum powder No. 320 shall be lightly sprinkled onto a glass plate and a little water added.

The clay sample shall be ground down using a circular motion. When the sample approaches the required thickness powder No. 320 shall be replaced by No. 600. Care should be taken to remove all traces of the coarse powder as this may tear the sample.

The sample shall be periodically inspected under the microscope to determine the termination of the grinding operation.

