



Durham E-Theses

Studies of fission induced by 14 MeV neutrons

Brown, Mary Gladys

How to cite:

Brown, Mary Gladys (1965) *Studies of fission induced by 14 MeV neutrons*, Durham theses, Durham University. Available at Durham E-Theses Online: <http://etheses.dur.ac.uk/8714/>

Use policy

The full-text may be used and/or reproduced, and given to third parties in any format or medium, without prior permission or charge, for personal research or study, educational, or not-for-profit purposes provided that:

- a full bibliographic reference is made to the original source
- a [link](#) is made to the metadata record in Durham E-Theses
- the full-text is not changed in any way

The full-text must not be sold in any format or medium without the formal permission of the copyright holders.

Please consult the [full Durham E-Theses policy](#) for further details.

" Studies of fission induced by 14 MeV neutrons "

THESIS

presented in candidature for the degree of

DOCTOR OF PHILOSOPHY

in the

UNIVERSITY OF DURHAM

by

MARY GLADYS BROWN, B.Sc. (Dunelm)



P.216

MEMORANDUM

The work described in this thesis was carried out in the Londonderry Laboratory for Radiochemistry, University of Durham, between September 1961 and September 1964 under the supervision of Dr. S.J. Lyle, Lecturer in Radiochemistry.

This thesis contains the results of some original research by the author; no part of the material offered has previously been submitted by the candidate for a degree in this, or any other University. When use has been made of the results and conclusions of other authors in relevant investigations, care has always been taken to ensure that the source of information is clearly indicated, unless it is of such a general nature that indication is impracticable.

M.G. Brown .

ABSTRACT

The fission yields of ten nuclides (^{84}Br , ^{91}Sr , ^{93}Y , ^{99}Mo , ^{105}Ru , ^{112}Pd , ^{113}Ag , ^{129}Sb , ^{132}Te and ^{143}Ce) from the fission of ^{231}Pa by 14 MeV neutrons have been determined relative to the fission yield of ^{97}Zr . The protactinium (as oxide) in thin uniform adherent layers (about 1 mg. cm^{-2}) lightly covered with gold (about 0.5 mg. cm^{-2}) was supported on circular discs of platinum foil (2 cm. diameter). Recoiling fission products were collected in thin catcher foils of various substances (aluminium, polystyrene or copper) the choice depending on the elements to be recovered. Preliminary experiments using target discs prepared in a similar way from uranium-238 (oxide) showed that good agreement is obtained between relative yields measured by this method and by irradiation of bulk samples of uranium.

The relative yields from ^{231}Pa have been corrected to total chain yields by application of the equal charge displacement hypothesis and converted to absolute yields by imposing the condition that the sum of the yields of all the fission products must be 200%. The value of $\bar{\nu}$ was taken to be 4.25; this was found to give a good fit of reflected points on the mass yield curve.

When chain yields are plotted against mass number a mass-yield curve is obtained showing three maxima at mass numbers 93, 114 and 135. The yields at the maxima are 6.80%, 2.48% and 6.80% and the peak widths at half height are 14, 17.5 and 14 mass units.

CONTENTS

	Page
<u>CHAPTER 1.</u> Introduction	
(i) (a) General.	1
(b) The fission process.	2
(c) Fission yield.	6
(d) Mass distribution in fission.	9
(ii) Summary of fission studies relevant to the work undertaken.	19
<u>CHAPTER 2.</u> Experimental procedure and apparatus.	25
(a) Outline of investigations.	25
(b) Preparation of uranium deposits.	26
(c) Preparation of protactinium deposits.	28
(d) The neutron generator.	33
(e) Arrangements for irradiations.	35
(f) Preparation of solid sources.	36
(g) Counting equipment.	38
(h) Choice of reference element.	42
(i) α contamination in sources from protactinium.	43
(j) Catcher foil materials used.	46
(k) Calibration of the end-window counters.	48
<u>CHAPTER 3.</u> Measurement of relative yields from the fission of uranium.	52
(a) General treatment of results.	52
(b) Relative yields of nuclides investigated.	56
(c) Discussion.	61

	Page
<u>CHAPTER 4.</u> Measurement of relative yields from the fission of protactinium.	68
<u>CHAPTER 5.</u> Collected results for Protactinium.	91
(a) Correction of measured yields to total chain yields.	91
(b) Discussion.	94
<u>APPENDIX.</u> Chemical procedures.	101
(1) Zirconium.	101
(2) Barium.	103
(3) Bromine.	104
(4) Strontium.	105
(5) Yttrium.	107
(6) Molybdenum.	109
(7) Ruthenium.	110
(8) Palladium-Silver.	111
(9) Silver.	113
(10) Antimony.	114
(11) Tellurium.	116
(12) Cerium.	117

REFERENCES.

ACKNOWLEDGEMENTS.

1. Introduction

(a) General

Nuclear fission resembles several other notable scientific discoveries in that it was first observed in an experiment performed with quite different objectives and the results were at first misinterpreted. The discovery arose from investigations following a suggestion made by Fermi¹ in 1934 that it should be possible to produce elements higher in atomic number than uranium by bombarding this element with neutrons. The formation of uranium isotopes decaying by β^- -emission would give rise to transuranic elements, which, it was thought, would resemble manganese, technetium and rhenium. A number of investigations were made and it seemed at first that the predictions of Fermi were being fulfilled but the work of Hahn and Strassmann² established that in reality the uranium nucleus was being split and the observed activities were attributable to isotopes of lighter atoms such as barium and strontium.

Other workers followed Hahn and Strassmann and a review by Turner³ written in 1940 summarizes the early work dealing with various theoretical and practical aspects. It had been pointed out that the splitting of a heavy atom into light fragments would release a considerable amount of energy⁴ and interest soon turned to potential applications. It was also discovered that neutrons were emitted during the process⁵ thus

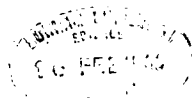

suggesting the possibility of establishing a self-propagating system by means of a chain reaction. Because of the military and political interest of these discoveries most of the work was classified as secret in particular that of the 'Manhattan Project' which resulted in the production and use of the first atomic bomb. Since the end of the 1939-1945 war much of this material has been released in the volumes of the 'National Nuclear Energy Series'; those on the fission products⁶ contain much radiochemical information.

In more recent years investigations have continued into many aspects of the process and the volume of literature is now considerable. A number of reviews have been published which include this later work, for example those of Halpern⁷, Walton⁸ and Hyde.⁹

(b) The Fission Process

The name fission was first suggested by Meitner and Frisch⁴ soon after the discovery of the process. Nuclear fission is the splitting of an atomic nucleus into at least two fragments of comparable size accompanied by emission of gamma rays, neutrons and, occasionally other light fragments. In most fission events only two particles other than neutrons are produced but occasionally three are formed; the process is then known as ternary fission. Three types of ternary fission have been investigated. The best established example occurs when the third fragment is an α particle with an energy

of up to 29 Mev. It was first observed in 1943¹⁰ and is said to occur with a frequency of 1 in every 400 binary fission events.¹¹ Another type arises from the nucleus splitting into three fragments of comparable mass. This is apparently very uncommon; one value for the frequency in neutron induced fission of ^{235}U is 6.7 ± 3.0 events in every 10^6 binary fissions.¹² It has also been claimed that ternary fission occurs in which the third particle is some light fragment of low atomic number (1 or 2) and of about 1 Mev in energy, in up to 1% of fission¹³ events but the results have been questioned.¹⁴

In binary fission the heavy fragments so far observed fall within the range of mass numbers 72 to 162. In each fission the fragments formed may be of approximately equal mass or one heavier and one lighter fragment may be produced.

The number of prompt neutrons emitted per fission is between 2 and 5 (e.g. in the spontaneous fission of ^{238}U there are 2.4 neutrons per fission)¹⁵ so that the fission fragments produced have approximately the same neutron to proton ratio as the original nucleus; they are therefore well removed from stability and decay by a chain of β^- emissions. The early members of these fission fragment chains normally have extremely short half-lives and are not usually observed in radiochemical work. The chains are frequently complex and not all are yet known with certainty.¹⁶ Some examples of

decay chains are:-

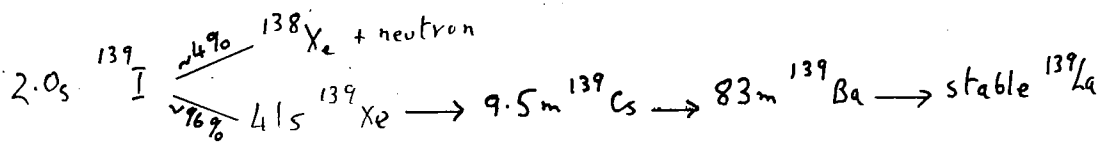
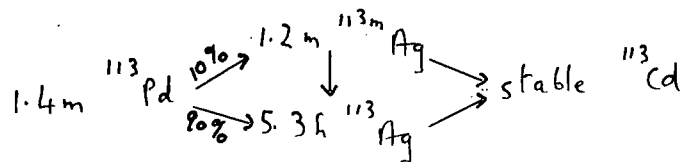
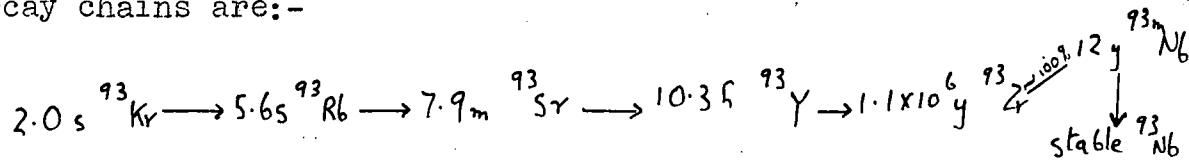

In fission the prompt neutrons are emitted within a very short time (less than 4×10^{-14} sec.¹⁷) of the moment of scission of the nucleus. About 1% of all the neutrons emitted are, however, those known as delayed neutrons.

They are produced during the decay of the fission fragments some of which are unstable to neutron emission. Six active precursors of delayed neutron emitters have been identified with half-lives of 0.05 to 55 secs. A review of this topic is given by Keepin and Wimett.¹⁸

Fission may be distinguished from spallation and fragmentation which also lead to the breaking up of the nucleus. In spallation reactions a number of nucleons are emitted but the residual nucleus is normally within 10-12 mass units of the target nucleus. In fragmentation processes the nucleus splits into a number of large and small fragments.

When fission is induced by particles of low to moderate energy it is usually considered to proceed by a mechanism of compound nucleus formation,¹⁹ that is, the incoming particle is captured by the nucleus and its energy is distributed among all the nucleons. The nucleus produced is excited to some energy determined by the energy of the incoming particle and the binding energy released when it is absorbed into the nucleus. This nucleus then decays by one of a number of possible ways. It is assumed that the decay of this compound nucleus is not influenced by its mode of formation. At higher energies of bombarding particles fission is in competition with spallation reactions and neutron emission and the compound nucleus mechanism may not be applicable.

From a consideration of atomic masses it may be shown that all heavy nuclei are unstable with respect to division into two equal parts. For example, if ^{194}Pt was divided into two, ^{97}Y would be produced; this has a large neutron excess and a chain of β^- -decays would lead to the formation of stable ^{97}Mo . The exact mass of two ^{97}Mo atoms is 193.8738 amu and that of a ^{194}Pt atom is 194.0240 amu giving an energy release for fission and β^- decay of about 140 Mev. Despite this large apparent instability neither platinum nor most of the heavy elements are spontaneously fissile. Spontaneous fission is observed with low probability in some nuclides, for

example the half-life is 2.7×10^{17} years²⁰ for ^{235}U , but it is a common occurrence among the heaviest transuranic elements such as ^{254}Cf (half-life = 55 d.)²¹ It has been shown that the barrier against fission is about 5-10 Mev for most heavy elements but it is apparent that when the nucleus is sufficiently excited to overcome this barrier the energy released is considerable. Nuclei are excited above the barrier height by bombarding the target with projectiles of appropriate energy. For example, the first experiments were carried out by bombarding natural uranium with slow neutrons when a neutron is captured by ^{235}U to give ^{236}U excited to about 6 Mev; this energy is sufficient to overcome the barrier and allow fission to take place. Fission has now been observed in elements as light as copper²² and has been induced by bombardment with projectiles of many energies and ranging from γ -rays to ions derived from substances such as carbon or nitrogen.

(c) Fission Yield

When fission takes place the atoms produced (normally known as fission fragments or fission products) show a considerable range of mass numbers; elements from zinc to the heavier lanthanides have been identified in fission fragments.

In order to express the fraction of fission events in which nuclei of any mass number A are formed the term fission yield is defined as a percentage, F , where

$$F = \frac{(\text{No. of product nuclei of mass number } A) \times 100}{(\text{Total no. of fission events occurring})}$$

Measured values of F represent either independent or cumulative yields. The independent yield of a particular nuclide is the number of fission events which lead directly to that nuclide. Frequently, these yields are difficult to determine since most nuclei are also formed by the decay of others and the half-lives of the first few members of a chain are normally very short. For example, in the decay chain for mass 93 the first two members have half-lives of 2 secs. and 5.6 secs. respectively so that it would require special techniques to measure the independent yields of the next member of the chain, 7.9 min. ^{93}Sr . If the precursor of a nuclide is long lived or stable, independent yields may be determined and this has been done for a few nuclides (e.g. $^{140}_{\text{La}}^{23}$). Most of the measured fission yields however, are cumulative. The yield represents the total yield of a given chain up to the nuclide on which the measurement is made, that is, the sum of its independent yield and the independent yields of its precursors. For example, in the decay chain for mass 93, if the yield of the fourth member (10.3 h. ^{93}Y) was measured about 80 minutes after the end of an irradiation this would represent the cumulative yield of the chain to this point. It would not, however, represent

the total yield of the chain as ^{93}Y is followed by two more isotopes. Normally the nuclide which is chosen for measurement will not be the last in the chain (since this will be stable) and may be considerably removed from the end of the chain. The total chain yield must therefore be calculated and two hypotheses have been suggested which provide methods for doing this. One postulates that the fission fragments retain the same neutron to proton ratio as the original nucleus (unchanged charge distribution)²⁴ and the other that the most probable charge for one fission fragment and its complementary fragment lie an equal number of units away from stability (equal charge displacement²⁵). The equal charge displacement approach may be expressed by the relation:-

$$Z_A - Z_P = Z_A^* - Z_P^*$$

where Z_A and Z_A^* are the most stable charges of the complementary chains and Z_P and Z_P^* are the most probable charges for the primary fission fragments of mass number A and A^* .

Both have been applied to different types of fission with the equal charge displacement hypothesis usually considered to be the more appropriate for fission at low or moderate energies.

Measurements of fission yields have been made by both chemical and mass spectrometric techniques the results frequently being complementary. Considerable accuracy may

be attained by the use of the mass spectrometer but it is necessary to obtain enough material for the preparation of sources and such methods are therefore only applicable where a high flux of bombarding particles is available, or fission products have been able to accumulate over an appreciable time. Radiochemical methods, on the other hand, can be used where amounts of material are low, but they are less precise.

If fission yields are to be determined absolutely a knowledge of two things is required. (a) The number of atoms of the nuclide formed and (b) the number of fission events occurring in the material. The first requirement may be met by the use of mass spectrometry or the usual methods of absolute activity determination. The number of fission events is more difficult to determine. Briefly, it may be assessed by simultaneously irradiating a sample of the material in a fission counter or by comparison with the yield from some other reaction (if the ratio of the cross sections is accurately known). A procedure often used is to determine all yields relative to one chain the yield of which may be absolutely determined. Even if this measurement is not made the values may still be made absolute since, assuming that each fission event gives rise to two fragments, the sum of all chain yields must be 200%

(d) Mass Distribution in Fission

When cumulative chain yields are plotted against mass numbers

of chains the so-called mass-yield curves are produced. Radiochemical investigations of fission are frequently directed towards the determination of mass yield curves and they are now established for many fissioning systems. They have also been determined by measurements of the kinetic energy of the fission fragments since this varies in a similar way to fission yields. An example which has been studied by this method is the fission of ^{235}U ²⁶ with slow neutrons.

When the mass-yield curves for fissioning systems are compared a number of differences may be observed, although many are of the same general form. The most thoroughly investigated system has been ^{235}U fissioning with neutrons in thermal equilibrium with their surroundings (thermal neutrons)¹⁶ and this may be taken as a typical distribution. For this system the curve is found to have two peaks which are centred about light and heavy masses of the fission fragments; the peaks are joined by a trough in the medium mass region. That is, an asymmetric splitting of the nucleus is occurring in most fissions with relatively few fissions giving rise to symmetric splitting. The ratio of yields on the peaks to those in the trough is found to be 600 : 1.

The curve found under such conditions may be compared with the curves for fission induced by neutrons of higher

energies, that is, at higher excitation energies of the fissioning nucleus, or with those found for spontaneous fission, that is, at zero excitation energy of the fissioning nucleus. For spontaneous fission two peaks are again observed in the curve at light and heavy masses but these are much narrower than for fission induced by thermal neutrons and the yields of fission fragments from symmetric fission have not so far been measurable. An example is the spontaneous fission of ^{242}Cm .²⁷ In the mass yield curves for fission induced by neutrons of higher energy the peaks at light and heavy masses are again found but the yield of symmetric fission increases. For example, in the fission of ^{235}U with 14 Mev neutrons the peak to trough ratio is about 7 : 1. With increasing energy there is also an increase in the yield of very asymmetric fission which is shown in a gradual widening of the two peaks in the curve. The yields of moderately asymmetric fission have not been observed to increase by more than 1 - 2% as the energy of the bombarding particles increases.

At higher energies still, only one peak is observed in the curve; this is centred about the symmetric fission region but it is very broad and indicates that the yields of symmetric and asymmetric fission are comparable. An example of this type of distribution is found in the fission of ^{238}U with 150 Mev protons.²⁸ An example of mass-yield

curves from one nuclide fissioning with the same bombarding particle at a range of energies is given in a series of curves for the fission of ^{239}Pu with deuterons of energies from 9.2 to 23.4 Mev.²⁹ The trends towards filling of the trough and increase in the yields of very asymmetric fission as the energy increases are again observed.

These trends have been taken to indicate that the probability of asymmetric fission is not strongly dependent on the excitation energy of the fissioning nucleus while the probability of symmetric fission is a rapidly increasing function of the excitation energy. Following this it has been suggested⁵⁰ that symmetric and asymmetric fission are manifestations of fundamentally different types of nuclear reaction and that the observed mass-yield curves represent the superposition of the characteristics of the two modes. It is often rather difficult to interpret the measured data as a function of excitation energy; this arises since fission may take place either immediately after the capture of an incident particle or only after the emission of one or more neutrons from the compound nucleus. Fission takes place at a higher excitation energy before neutron emission than after and many of the measurements which have been made therefore represent average values for nuclei fissioning at a range of excitation energies and compound masses. A study of the ratio of symmetric

and asymmetric fission in the proton induced fission of ^{232}Th , ^{238}U and ^{239}Pu has been made which avoids these complications. The target nuclei were bombarded with protons of well defined energy in the range from 5 to 100 Mev and measurements made of the yields of ^{113}Ag relative to those of ^{139}Ba . When these ratios, which represent the ratio of symmetric to asymmetric fission, were plotted against proton energy a general increase was observed with increasing energy. Superimposed on this for ^{238}U , and especially for ^{232}Th , were a number of discontinuities where the symmetric fission yield fell only to rise again as the energy was further increased. These occurred where emission of one or more neutrons would be expected to take place before fission, thus reducing the excitation energy of the fissioning nucleus. Six discontinuities were observed for thorium and five, rather less pronounced, for uranium. None were observed in the plutonium curve but this nuclide is more highly fissionable than uranium or thorium so that there is a smaller probability that neutron emission will occur before fission has taken place. These results would seem to support the view that the yield of symmetric fission is dependent on the excitation energy of the fissioning nucleus.

When investigations were carried out on elements lighter than thorium the forms of the mass-yield curves were

found to be strikingly different from those observed for heavier elements. The first study of this type of fission was that of Fairhall on the fission of bismuth with 15 and 22 Mev deuterons.³² The curve obtained showed only one maximum, in the region of symmetric fission. It was much narrower than the single peak found in the high energy fission of heavier elements and indicated a rather low probability for asymmetric division of the excited nucleus. This type of curve has also been found for the fission of lead with upto 42 Mev helium ions³³ and for radium with 22 Mev deuterons.³⁴ For radium the peak is broader and there is a suggestion of two small peaks in the asymmetric fission region. Some work on the fission of lead with 41 Mev helium ions³⁵ also suggests the presence of a peak at light masses. The fission of radium with neutrons³⁶ has also been investigated (by a kinetic energy technique) and it can be seen that as the energy of the neutrons is increased from 4 to 12 Mev the fragment energy distribution (and therefore the mass distribution) changes from a distribution with two peaks (at light and heavy masses) at the lower energies, to one with a single peak, at higher energies. When the fission of radium with 11 Mev protons³⁰ was investigated a distribution with three peaks of equal height was observed. The peaks at light and heavy masses were in a similar position to those found for the fission of heavier elements and the peak in symmetric fission yields was similar to the single peak observed

for bismuth fission.

Mass yield curves have also been investigated for the fission of rhenium with helium ions of 31 to 44 Mev.³⁷ At 31 Mev the curve had three peaks and at 44 Mev symmetric fission was predominate. Rhenium is the lightest element for which mass-yield curves have so far been determined; in this mass region the fission cross-sections become very low (of the order of microbarns) and amounts of fission fragments are therefore very small.

It has been suggested³⁷ that comparison of all these distributions shows that asymmetric fission is associated with nuclei which have deformed shapes in the ground state. The heaviest nuclei are known to be highly deformed and fission is largely asymmetric (at least at low and medium energies) while in the region of lead and bismuth the nuclei are stabilized in a spherical shape under the influence of the 82 proton and 126 neutron shells and symmetric fission is predominate. For lighter elements the ground states are again deformed and fission is again largely asymmetric.

Mass distributions with three maxima have also been observed in the fission of ^{233}U with helium ions of energies from 25 to 40 Mev;³⁸ there is some indication of a small peak in symmetric fission yields in the fission of thorium with pile neutrons³⁹ but this is less well established.

It has been shown that cumulative chain yields are not necessarily smooth functions of mass, discontinuities (fine structure) have been observed in the curves based on mass-spectrometric measurements. These are well established for ^{235}U where there is a small peak at mass 134⁴⁰ with a complimentary peak at mass 100.⁴¹ The xenon isotopes first investigated lie close to the 82 neutron shell and it has therefore been considered that the high yield might be accounted for by some preferential formation of closed shells in fission.⁴² This could occur if there was an inherent preference for the formation of closed shells in the fission act or if neutrons outside closed shells were evaporating after fission had taken place. The second alternative was proposed⁴³ to account for the peak at mass 134 but when high yields were also found for isotopes such as ^{99}Mo which are removed from closed shells this seemed less probable. Such nuclides are, however, complimentary fragments to those occurring at about mass 134 and if there is some preference for the formation of closed shells during fission the complimentary particle would also be formed in high yield. It has been claimed that high yields are observed in the region of the 50 proton⁴⁴ and 50 neutron⁴⁵ shells in the deuteron induced fission of uranium but the yields are changing rapidly with mass in this region and the effect is less pronounced. Fine structure has also been

observed in the fission of ^{239}Pu with thermal neutrons⁴⁶ and in the spontaneous fission of ^{242}Cm .²⁷

Another well established feature of the mass-yield curves is that when the distributions for the various fissile nuclides are compared the position of the maximum in yields of heavier fragments is found to remain almost constant while that in yields of lighter fragments moves to heavier masses as the mass of the fissioning nucleus increases. This is found whenever asymmetric fission occurs even though symmetric fission may be the predominant mode. For very heavy nuclei such as ^{254}Fm ⁴⁷ a slight shift of the peak in heavy fragment yields to heavier masses has been found.

This effect has been attributed to the influence of the 82 neutron shell on the mass split.⁴⁸ Alternatively, it is suggested⁴⁹ that the nucleus retains some of its internal shells intact and that these pass to one of the fission fragments together with half of the remaining nucleons. One suggestion for ^{235}U fission is that the core which is preserved approximates to $^{40}_{20}\text{Ca}$ in most fissions with some asymmetric fission on $^{56}_{28}\text{Ni}$ and some symmetric fission on $^{16}_8\text{O}$.⁴⁹

Several attempts have been made to provide theoretical explanations of the various features observed in the mass distributions and of other aspects of the fission

process which have been studied. A number of these have been based on the liquid drop model of the nucleus postulated by Bohr and Wheeler in 1939.¹⁹ The nucleus is treated as analagous to a charged drop of incompressible liquid and in the application of the model to fission the energy changes associated with various deformations are calculated. It has been found that the implications of the model are not easy to work out and it has been modified to take account of a number of different nuclear properties. For example, modifications have been made to allow for the effects of nuclear compressibility and charge distribution,^{50,51} and also for possible dynamic effects.^{52,53} As well as these developments of the liquid drop model other explanations, some of which have been mentioned above, have been based on the shell theory of the nucleus. The role of shell structure has been particularly emphasised in the work of Fong.⁵⁴ In his treatment it is assumed that the motion of nuclear matter is very slow so that all the degrees of freedom in the nucleus are in equilibrium until the moment of scission. The distributions of mass and charge are then determined by the number of states energetically available at scission. None of these approaches appear to have yet provided a complete account of the fission process; it may be expected that as more experimental data of a refined nature are accumulated a mechanism for the process may be evolved accounting for the observations.

(ii) Summary of fission studies relevant to the work undertaken

It has been suggested³⁴ that asymmetric division is dying out as a mode of fission among nuclides with mass numbers less than about 232. This suggestion is based mainly on observations on the fission of ^{226}Ra induced by deuterons,³⁴ protons³⁰ helium³⁴ ions and γ -rays;⁵⁵ assuming complete capture of the incident particle to form a compound nucleus the fissioning species will be ^{228}Ac , ^{227}Ac , ^{230}Th and ^{226}Ra respectively. For actinium compound nuclei the probability of symmetric fission is high. When radium is bombarded with 22 Mev deuterons the mass-yield curve has a maximum in the symmetric fission region and subsidiary peaks in the asymmetric region; with 14.5 Mev deuterons there are three maxima of which that in the symmetric fission region is rather higher and broader than the other two, while with 11 Mev protons three maxima of approximately equal height and width are observed. The probability of symmetric fission increases with the excitation energy of the compound nucleus but it is equal to or greater than the probability of asymmetric fission at each energy.

Where thorium compound nuclei are formed the probability of asymmetric fission is the greater. When radium is bombarded with 23.5 Mev helium ions the mass-yield curve has maxima at light and heavy masses with a small peak

in the symmetric fission region, this is more pronounced with 31 Mev helium ions and at 43 Mev the curve has one broad maximum indicating approximately equal probability for all mass divisions. Again the probability of symmetric fission increases with energy.

In the photofission of radium (with 23 Mev bremsstrahlung)⁵⁵ the mass-yield curve is similar to that observed with 11 Mev protons. A number of distributions have also been determined for radium bombardment with neutrons of 3 to 21 Mev³⁶ where the fissioning species will again be radium nuclei. Here the distribution is found to change from mainly asymmetric at 3 Mev to largely symmetric at energies above 8 Mev.

It appears that, for comparable excitation energies, the probability of symmetric fission is greater for radium and actinium than for thorium. The fission cross section represents a smaller proportion of the total cross section for radium and actinium than it does for thorium and it is possible that as the fission cross-section falls asymmetric fission is being suppressed.

Where the fission of thorium has been investigated using neutron bombardments of thorium itself the^{57,58,59} mass-yield distributions have usually resembled those observed for elements such as uranium, but it has been

suggested that a peak in symmetric fission yields is observed with pile neutrons.⁴⁰ A mass-yield distribution has also been determined for the fission of thorium with 9.5 Mev deuterons⁶⁰ where the compound nucleus will be ^{234}Pa ; this also has the form observed for uranium at moderate excitation energy.

Actinium and protactinium have not been investigated directly but only as compound nuclei formed in the bombardment of other nuclei. The longest lived protactinium isotope (^{231}Pa , half-life = $3.25 \times 10^4 \text{y}$ ⁶¹) has been separated from uranium wastes in gram amounts⁶² and a radiochemical investigation of the mass distribution should be feasible, provided that some technique can be used which will minimise the hazards associated with the handling of high λ -activities and allow complete recovery of the scarce target material. In mass ^{231}Pa lies between thorium, and actinium and radium, with their different types of mass-yield distribution; it may be more promising than thorium for a search for a definite increase in yields from symmetric fission.

The normal technique used for fission studies on materials such as uranium or thorium is to irradiate gram amounts of the material, dissolve it in an appropriate solvent in the presence of inactive carrier solutions and

separate a number of fission products from this solution. If such a method was applied to protactinium it would require lengthy treatment of the irradiated material to recover the protactinium and to ensure decontamination of the fission products; all the separations would have to be carried out in a glove box.

A method which has been used for some investigations is that of collection of the fission fragments as they recoil out of a sealed source. This was used, for example, in some qualitative work on uranium and thorium⁶³ and, more recently, in investigations of the mass-yield distributions in the fission of radium^{30,34} and bismuth.³² In this method the target material is permanently mounted and sealed with some thin covering; fission fragments are collected in a covering foil of some suitable material; it eliminates the need for decontamination of the fission fragments from macro-amounts of the target material which is preserved in a form suitable for immediate re-use. The method appears suitable for use with any scarce or highly active material provided that this can be suitably mounted.

There are, however, a number of uncertainties in the method which must be considered. These arise because the fission products are emitted with different energies, and,

in some cases, different angular distributions. The most probable energy of the heavy fragments is about 55 - 65 Mev and of the light fragments about 90 - 95 Mev; the losses by absorption in the target and covering material will be greater for fragments with lower energies and therefore there will be an apparent drop in the yields of heavy fragments compared with the yields of light fragments

If the fission fragments are emitted with different angular distributions discrepancies will again be found in the yields since there will be greater losses by absorption of those fragments which are emitted at about 90° to the incoming particles. It has been shown for thorium fission⁶⁴ (induced by 22 Mev protons) that the degree of anisotropy is greatest for fragments produced in asymmetric fission, that is, that these fragments have the greatest probability of being emitted along the beam of incoming particles, while for symmetric fission the distribution is more nearly isotropic. This situation could lead to apparently low yields of symmetric fission in a recoil method.

The range of the fission fragments will also have an effect in determining the thickness of deposit which can be tolerated before the amount of activity collected becomes too low for reliable measurement. The range of fission

fragments in uranium and uranium oxide is about 10 mg. cm^{-2} ⁶⁵ and if it can be assumed that this is similar for other systems it would seem reasonable to restrict the thickness to about $1-2 \text{ mg. cm}^{-2}$. This will mean that amounts of material which can be irradiated may be rather limited.

In order to investigate some of the various sources of uncertainty in the use of a recoil method preliminary experiments were carried out using ^{238}U . This is easy to handle, has a reasonable cross-section for fission induced by 14 Mev neutrons and the mass yield distribution is known; ^{66,67} the measurements were then extended to ^{231}Pa .

CHAPTER 2

Experimental Procedure and Apparatus

(a) Outline of investigations

Targets of uranium suitable for the collection of the fission fragments by recoil were prepared and irradiations were carried out using these targets and, simultaneously, a sample of about 1 gram of uranium oxide or hydrated uranyl nitrate. Various nuclides were separated and their fission yields determined relative to that of ^{139}Ba . The values obtained from the prepared targets were compared with those from the oxide or nitrate samples. In a few instances a bulk sample was not irradiated and the values of the relative yields were compared with published values;^{66,67} yields were determined for ^{97}Zr , ^{99}Mo , ^{105}Ru , and ^{113}Ag . Several different materials were used as foils to collect the fission fragments and the yields determined using these were compared.

Targets of protactinium were then prepared and these were used in investigations of the yields (relative to ^{97}Zr) of ^{84}Br , ^{91}Sr , ^{93}Y , ^{99}Mo , ^{105}Ru , ^{112}Pd , ^{113}Ag , ^{129}Sb , ^{132}Te and ^{143}Ce . (The reasons for the choice of reference elements is discussed below).

After irradiation of the targets and catcher foils

the catcher foils were withdrawn, dissolved in an appropriate solvent in the presence of inactive carrier solutions and a number of fission fragments (isotopic with the carriers) were separated. The separation procedures used in measurements on uranium were taken from published methods;⁶⁸ with protactinium, however, it was found that some active material was removed from the targets on to the catcher foils and a number of modifications were necessary to prevent contamination of the fission product sources.

When the nuclides to be separated had been purified they were mounted as solid sources for counting under a gas-flow, end-window, β -proportional counter. The counters used were calibrated using high specific activity solutions the absolute activities of which were determined by $4\pi\beta$ counting. The counting rates of a range of solid sources of known weight counted under the end-window counter were then compared with the disintegration rates found by calculation from the measurements using the 4π counter.

(b) Preparation of Uranium Deposits

Two methods, electrolytic deposition on gold and evaporation of an organic solution on platinum, were applied successfully to the preparation of suitable uranium deposits. A few attempts were made to enclose finely ground U_3O_8 between thin films but it was not found possible to make

films which were at once sufficiently strong to allow repeated use of the samples and which had sufficiently thin containing walls to allow the escape of the fission fragments.

In the electrolytic method⁶⁹ the deposits were prepared on one side of each of 24 gold discs, 2 cm. in diameter and 2.7 mg. cm.^{-2} in thickness. A solution $0.2M$ in ammonium oxalate and $0.02M$ in uranyl nitrate was adjusted to pH 8 with ammonia and electrolysed at $80^{\circ}C$ at 6 volts with a current density of $0.03 \text{ amps. cm.}^{-2}$ of the electrode. Electrolysis was continued until a thickness of about 1.5 mg. cm.^{-2} was built up; this was generally after about $\frac{1}{2}$ - $\frac{3}{4}$ hour. Deposition was on the cathode and one side was coated with black wax to prevent any deposit on the back of the electrode. A platinum wire was used as the anode. The deposit formed is stated to be UO_2 ; it appeared quite adherent and was black and shiny, but was rather uneven. The total weight of uranium deposited was 72 mg.

It was necessary to apply some cover to these deposits and this was done by the evaporation of gold from a heated tungsten filament under vacuum.⁷⁰ The thickness of the gold deposit was about 0.5 mg. cm.^{-2} and it formed a smooth, adherent deposit.

The deposits prepared by the evaporation of an organic solution⁷¹ appeared to be more uniform and to be more resistant to handling. A solution of uranyl nitrate in ethanol (50 mg. ml.⁻¹) to which a 3% solution of cellulose acetate in ethyl acetate was added was diluted with acetone. The final proportions, by volume, of uranium solution: cellulose acetate solution: acetone were 1:1½:1½. The mixture was painted on to platinum sheet in a thin layer and left to dry; the deposit was then heated to drive off all the organic material and convert the uranium to oxide. Any loose fragments were removed by rubbing with tissue. This procedure was repeated until the thickness was about 1 mg. cm.⁻² The platinum was coated on both sides and then cut into discs 2 cm. in diameter; the discs were then covered with a layer of evaporated gold 0.5 mg. cm.⁻² thick. Twenty eight discs were prepared giving a total weight of deposit of 168 mg.

(c) Preparation of Protactinium deposits

The preliminary investigations of a number of methods were carried out using either tantalum or niobium as substitutes since these are rather similar in chemistry to protactinium.

(i) Sublimation of halides

Samples of TaBr₅ and NbCl₅ were prepared in an atmosphere of dry, oxygen-free nitrogen; the tantalum pentabromide by

passing bromine vapour over heated tantalum metal, and the niobium pentachloride by passing chlorine saturated with carbon tetrachloride over heated niobium pentoxide. After a sample had been prepared it was sublimed along the tube in a nitrogen atmosphere and attempts were made to obtain a deposit on a piece of platinum in a cooled part of the apparatus. Only a small amount of any given sample could be collected on the platinum. The apparatus was then opened to the air when the halide was immediately hydrolysed to an oxide or basic chloride. Further halide was then sublimed on to the platinum and a thickness of 1 mg. cm.^{-2} was built up. The deposits were loose and powdery and considerable waste of the halide always occurred. It did not therefore appear to be a particularly encouraging approach for preparing satisfactory protactinium deposits.

(ii) Electrolysis of an Aqueous Solution

It is claimed⁷² that deposits of protactinium are prepared by the electrolysis of a fluoride solution to give thicknesses of up to 0.1 mg. cm.^{-2} . The solutions used contained $0.06 \text{ mg. ml.}^{-1}$, of protactinium and were $1M$ in NaF ; the pH was 5.9 and electrolysis was carried out at 1.5 volts with a current density of $15\text{-}20 \text{ mA.cm.}^{-2}$ of the electrode for 12 hours.

This was repeated using a tantalum solution but

visible deposits were not obtained.

(iii) Electrolysis of Organic Solutions

Two methods for the electrolysis of organic solutions were attempted. Deposits of protactinium have been prepared⁷³ on carbon anodes by the electrolysis of a di-iso-propyl ketone solution at 100-1000volts. The current was gradually increased to 2 mA. but was not permitted to exceed this value and deposition was 80% complete in 10-20 minutes.

A solution of niobium was prepared and extracted into di-iso-butyl ketone. The organic phase was then electrolysed under the above conditions, but with the use of platinum electrodes, for 16-17 hours. Deposits were obtained but the maximum thickness was 0.1 mg. cm.⁻².

The second method⁷⁴ has been used to prepare deposits of metals such as silver, platinum, uranium and a number of lanthanides. A solution of a salt is prepared in 3N acid to give a concentration of 10 mg. ml.⁻¹. About 25-250 μ l of this solution is then added to about 10 ml. of iso-propyl alcohol and electrolysed at 50-2000 volts (the required voltage varies for the different substances). Deposition is on the cathode and is complete in about 35 minutes.

A solution of niobium was prepared in strong hydrochloric acid to give a concentration of about 5 mg. ml.⁻¹

and treated as above. Thick white deposits were obtained which were apparently largely organic since on heating most of the material volatilised and a smooth white deposit remained. On repeated treatment a deposit of about 0.5 mg. cm.^{-2} was prepared on a platinum electrode; the deposit appeared to be adherent and could be easily covered with evaporated gold. The method was rather slow, however, and presumably considerable losses of material could take place during the volatilisation of the organic residue.

(iv) Evaporation of Organic Solutions

The method⁷¹ which had been used for the preparation of the uranium samples was tried out using a solution of niobium-pentachloride in alcohol and satisfactory deposits were obtained.

It appeared that the most promising methods for use with protactinium were those of electrolysing a solution mixed with iso-propyl alcohol or evaporating an organic solution. In the first method the deposit would be expected to be thick and powdery before heating and losses of material might be considerable. It was therefore decided to attempt the evaporation method (iv):

(v) The Preparation of Pa deposits

The deposits were mounted on platinum discs 2 cm. in diameter

and 0.002" thick. The discs were cut out before coating and then cleaned, heated to a dull red heat and weighed.

The whole of the procedure of preparing the protactinium deposits was carried out in a glove box. The protactinium (which was made available by UKAEA) was supplied as protactinium (V) chloride. This was soluble in absolute alcohol and a solution containing about 50 mg. ml.⁻¹ was made up in a dry vessel. Acetone and a 3% solution of cellulose acetate in amyl acetate were then added to give the proportions of protactinium solution:acetone:cellulose solution of 1:1 $\frac{1}{2}$:1 $\frac{1}{2}$. When the solution had been prepared no further precautions were taken to exclude water; such solutions were kept for several days without any apparent decomposition.

The solution was then applied to the platinum discs using a glass fibre brush (to reduce the amount of material retained by the brush); after treatment the discs were left to dry and then heated to dull red heat in a furnace for several minutes. They were then left to cool and rubbed with tissue to remove any loose fragments. It was hoped that if the discs were allowed to dry the protactinium halide would be hydrolysed before heating and losses by volatilisation would be reduced. Each coat applied in this manner gave a thickness of approximately 0.03 mg. cm.⁻²;

30 to 35 coats were applied to both sides of 24 discs giving an average thickness of 1 mg. cm.^{-2} and a total weight of deposit of 147 mg. (126 mg. of protactinium assuming a formula of Pa_2O_5 for the deposit).

The deposit was applied in thin layers and therefore interference colours could be observed at first. Since these alter as the thickness is increased it was possible to make some check on the uniformity of the deposit. When this had reached its full thickness the colours could no longer be seen and the deposit was white and shiny. It appeared to be quite adherent since vigorous rubbing or prolonged heating had no detectable effect on the weight of the discs. The deposits were covered with a layer of evaporated gold 0.5 mg. cm.^{-2} as described for the uranium discs.

(d) The Neutron Generator.

The neutrons are produced by the reaction:-

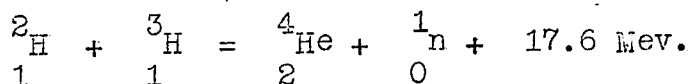

which has a high, broad resonance for deuterons of 100 kev striking a thin tritium target. In this laboratory a suitable beam of deuterons is produced by a Cockcroft-Walton linear accelerator.⁷⁵ During operation the beam current varies from about 50-180 μ amps. the energy of the deuterons being about 160 kev; the neutron flux produced is of the

order of 10^9 n/sec.

This beam of deuterons impinges on a target of tritium adsorbed onto a titanium or zirconium foil supported on a 2.5 cm. diameter copper foil which is fixed to the copper target block with Woods metal. The targets, which are described by Wilson and Evans,⁷⁶ are obtained from UKAEA and each contains about 3 curies of tritium. During irradiation the heat dissipated in the target is about 25 watts; the target is therefore water cooled to reduce the loss of tritium by heating of the target. The target assembly is illustrated in Fig. 1; it is sited in the middle of the target chamber in order to reduce the flux of neutrons of degraded energy produced by scattering from the walls etc.

The energy of the neutrons produced varies somewhat with the angle of emission and with the energy of the deuterons. It has been stated that the energy of the deuterons is about 160 kev but when the beam strikes the target energy will be lost so that in fact deuterons of energies from 0 to 160 kev will be present. The excitation function of the reaction,⁷⁷ shows that 80% of the neutrons are produced by deuterons of energy from 80-130 kev. When neutron energy is plotted as a function of angle of emission for deuteron energies of 80, 100 and 140 kev. (Fig. 2) it is found that, assuming an angle

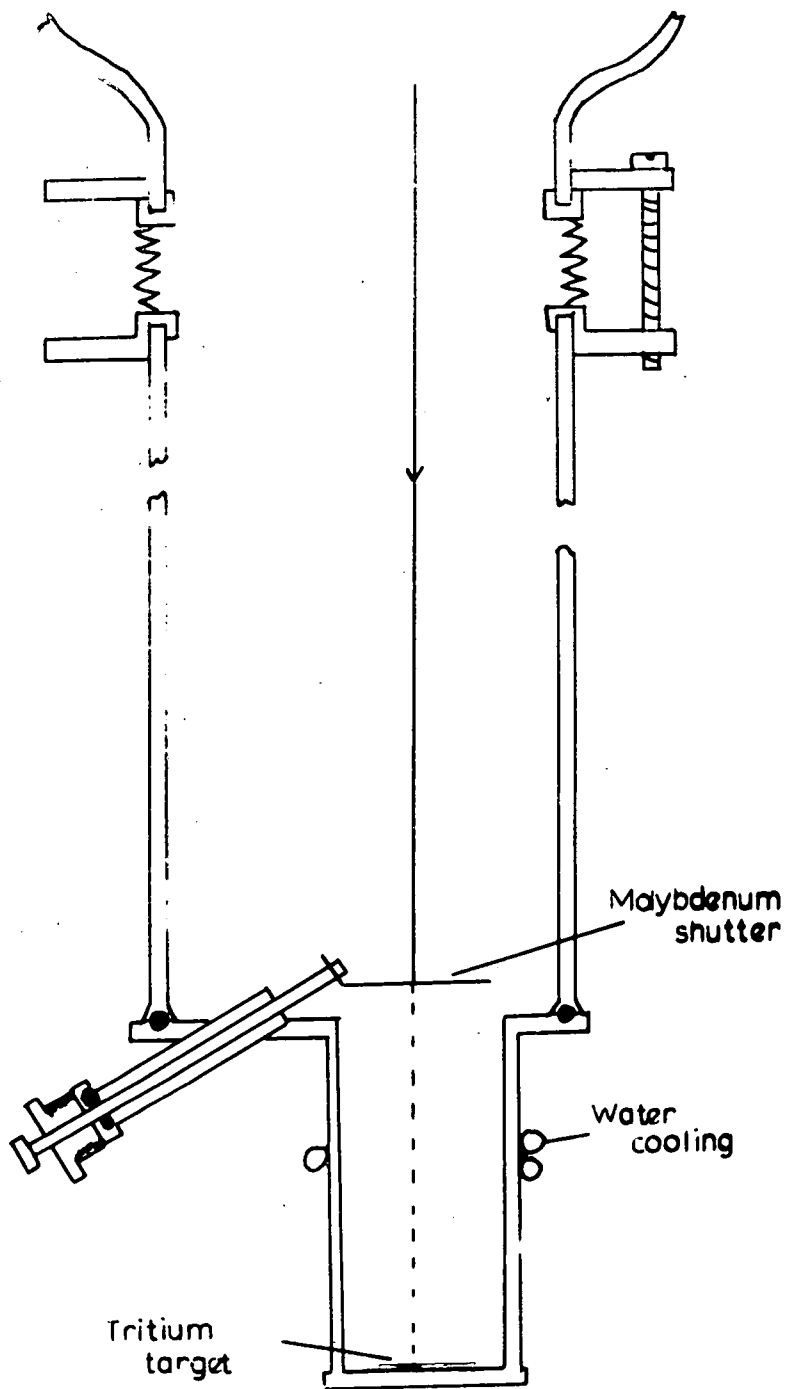

Fig.1. Target Assembly

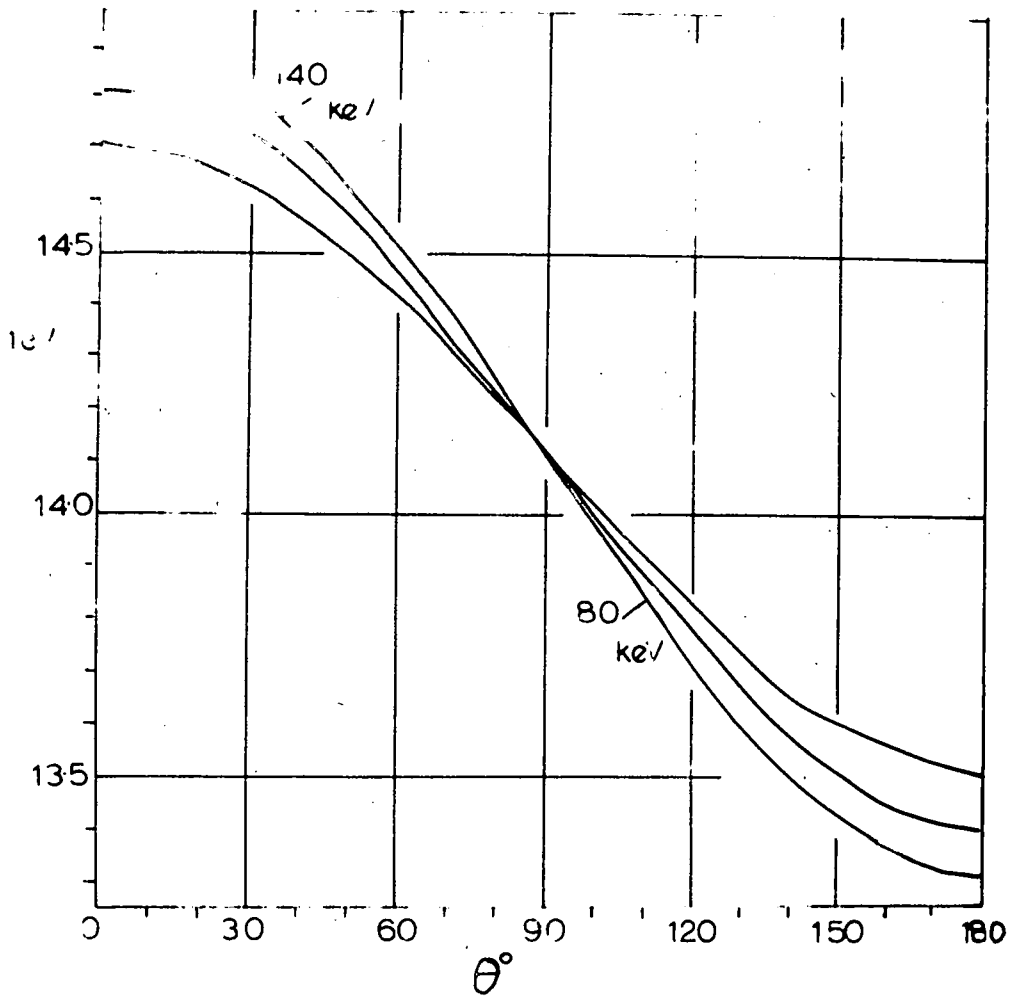

Fig.2./ Neutron energy as a function of angle
of emission

subtended at the target of 90° , the variation of neutron energy is from 14.1 to 14.9 Mev. This gives an average energy of 14.5 ± 0.4 Mev, that is, with a variation of $\pm 3\%$. If the irradiations can be carried out so that the angle subtended at the target is small, the energy spread can be reduced but to do this the sample for irradiation must be placed several centimetres from the target and therefore the flux is much reduced.

During irradiation of a given target the flux falls continuously, probably because of the loss of tritium. Deposits of decomposed oil from the diffusion pumps may also form on the target at times, although a cooling device is included to reduce this. As the targets age there will be some accumulation of deuterium and therefore the production of low energy neutrons from the $D + D$ reaction becomes possible. These have been shown to introduce an error of not more than 2% in work on uranium fission.⁶⁶

The neutron flux varies throughout an irradiation and is monitored using a plastic scintillator. Allowance is made for the flux variation in the calculation of the relative yields. (see Chapter 3)

(e) Arrangements for Irradiation.

For irradiation the prepared uranium or protactinium discs

were interleaved with catcher foils and placed in a holder. For the measurements on uranium, circular catcher foils (2 cm. diameter) were used and the discs and foils were held in a round polythene container with a closely fitting polythene plunger. This was strapped to the target block of the accelerator with elastic bands. When protactinium was to be used other arrangements were necessary because of its high α -activity. The discs were always kept in a glove box except during the actual irradiation. Before removal they were interleaved with square catcher foils (2 cm. square) in a brass holder. This was then sealed into two polythene bags and taken from the glove box when it was placed in a third bag. The assembly was then checked for α -activity using a Burndep't monitor Type BN 110 Mk III with an α -probe Type EN III Mk II operating at 1.4 Kv., and fixed to the target block of the accelerator.

After irradiation the packet was returned to the glove box, opened, and the catchers removed for separation of the fission products.

(f) Preparation of Solid Sources.

If solid sources are to be counted it is convenient that the final form used for precipitation and source preparation should also be suitable for the gravimetric determina-

tion of the chemical yield. It is also necessary to use a standard mounting technique for all sources to allow relative measurements to be made.

Sources were mounted on glass fibre discs (Whatman GF/A); which before use were washed with water, alcohol and ether (in that order) and dried in a vacuum dessicator. This was evacuated for one minute, air admitted and then evacuated for 5 minutes. The disc was then mounted on an aluminium planchet and weighed to the nearest 0.01 mg. using a Stanton semi-micro balance (Model MCIA). These discs were found to give constant weighings over a period of several days even if kept in the air.

To prepare a source the weighed disc was placed on a sintered polythene disc, having a diameter slightly greater than that of the disc, which was located in the base of a filter stick. The top of the stick had an internal diameter about $\frac{1}{8}$ " less than the diameter of the disc and was held in place with a clip. Filtration of a slurry of the source material then gave a clearly defined area which was reproducible for any source. The sources were washed, dried and weighed as described for the mounts. The balance weights were accurate to ± 0.05 mg. and the source weights were usually between 5 and 40 mg. The chemical yield, assuming that the composition of the precipitate is accurately known, could

therefore be determined with an accuracy of about $\pm 1\%$.

(g) Counting Equipment.

The solid sources were all counted under a gas-flow, end-window, β -proportional counter. The gas was a standard mixture of 90% argon and 10% methane; before use it was dried by passing through a series of tubes containing silica gel and magnesium perchlorate. It then passed through a glass wool filter to remove any dust and then to a reducing valve and flowmeter. The gas was supplied to the counters at about atmospheric pressure and at an approximately constant flow rate (small changes in the flow rate could be shown to have no effect on the counting rate of a given source).

While measurements on uranium were in progress the counter shown in Fig. 3. was used. This had a window made from several layers of very thin VYNS plastic film giving a final thickness of about $80 \mu\text{grm.cm.}^{-2}$. This was coated on the inside with a thin layer of evaporated gold to ensure that a uniform field was preserved inside the counter. The central wire was a loop of constantin wire (0.001" in diameter) soldered into a nickel tube which in turn passed into a insulated plug. The main body of the counter was of polished brass.

This type of counter gave a plateau 200-300 volts long with the optimum operating voltage at about 1.8 kv.

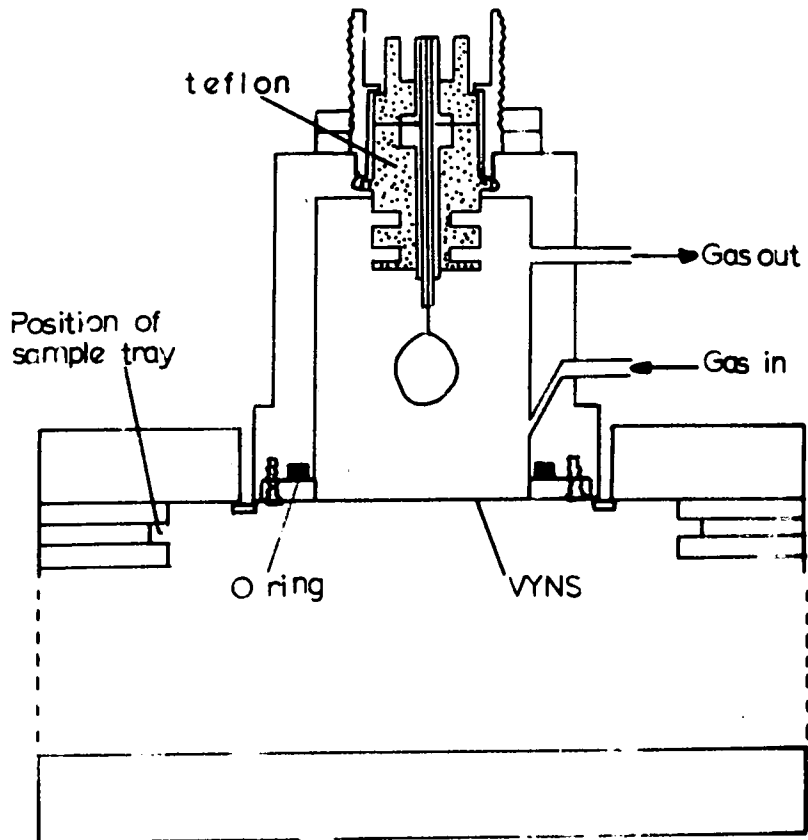

Fig.3. Proportional Counter (used in measurements on uranium)

This changed slightly over a period of time and the plateau was therefore re-determined at intervals. Operating at this voltage and enclosed in a lead castle the counter gave a back-ground counting rate of 10-15 cpm. The efficiency was frequently checked by counting a standard radium-D,E-F source the count rate of which always fell within the expected statistical limits. The electronics and gas system associated with this counter are shown in block diagram form in fig. 4. The amplifier and scaler settings are given below:-

<u>Amplifier</u>	Type 1008
Differentiation time	0.4 μ secs.
Integration time	0.4 μ secs.
Attenuation	10 db.
<u>Scaler</u>	Type 1009A
Paralysis time	50 μ secs.
Discriminator bias	15 volts.

This counter was also used to investigate the presence of α contamination in sources prepared from protactinium. For this purpose the paralysis time of the scaler was increased to 1000 μ secs. and the counter was operated at 1 kv. The counter was not calibrated as it was only used in measurements to compare yields from uranium foils

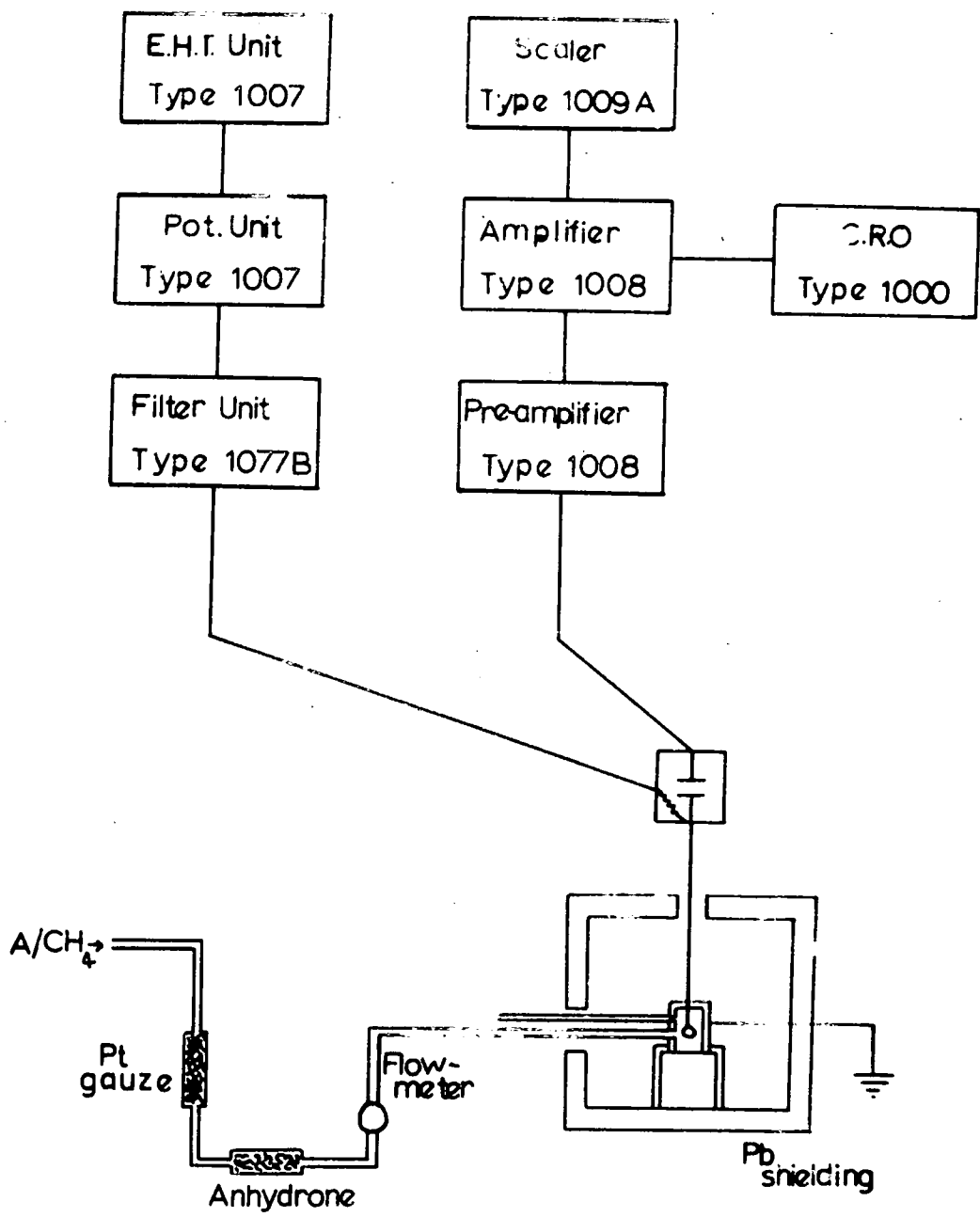

Fig.4. Gas flow system and electronics

and bulk uranium samples.

For some of the measurements on protactinium low-background counters were used. The end-window counters were essentially the same as the type described above except in shape. One is illustrated in fig. 5. The windows were prepared from 1 mg. cm^{-2} Mylar film which has the advantage of being much more robust than VYNS and of allowing up to three counters to be operated in series from the same gas supply without loss of efficiency. The windows were prepared by heating the brass window support and stretching a piece of film over it. When the correct temperature was used the film stuck firmly and gave a smooth window. They were coated with gold in the same way as the VYNS windows. These counters were operated under a shield of Geiger counters (Twentieth Century Electronics Type G24). The arrangement is illustrated in fig. 6. The electronics associated with these counters is shown in block diagram form in fig. 7. Since an anti-coincidence circuit is included, pulses from the proportional counter coincident with those from the Geigers are not recorded. This serves to reduce contribution of cosmic rays, or active substances in the surrounding material to the background counting rate. The amplifiers used were based on the design of Chase and Higinbotham⁷⁸ for a general purpose linear pulse amplifier

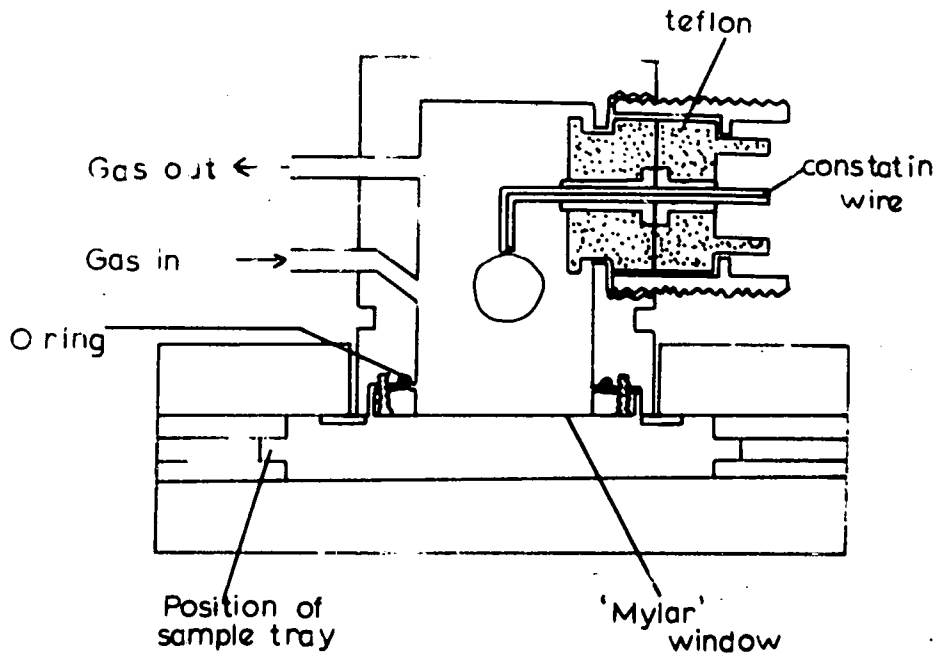

Fig. 55 Proportional Counter (used in measurements on protactinium).

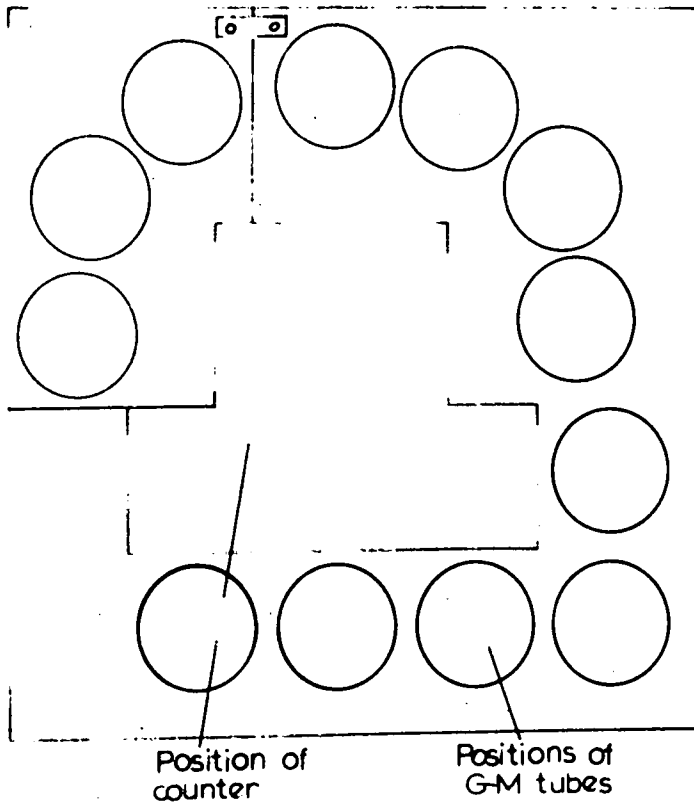

Fig.6. Arrangement of Geiger shield

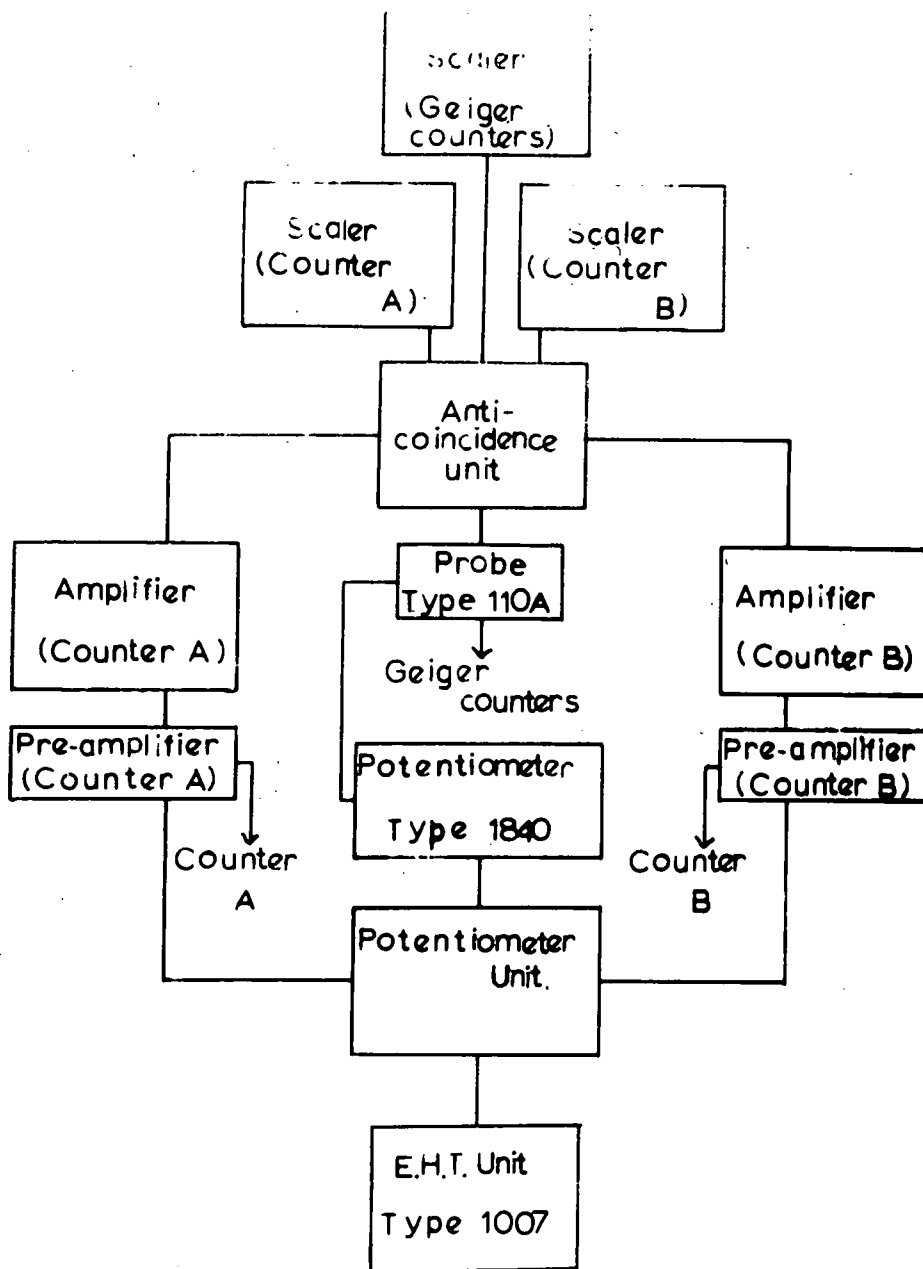

Fig.7. Block diagram of electronic system.

with good stability, short-rise time and good overload characteristics. The dead time was adjusted to 1.8 msec. since some α -activity was expected to be present in the sources; with the shorter dead times often used for proportional counting the large pulses produced by α -particles can overload the amplifiers. The preamplifiers were mounted directly on the body of the counter to reduce losses due to stray capacitances of plugs and leads. With the anti-coincidence shield operating and the counters enclosed in a lead castle, the background count rate was 5-6 cpm. If the anti-coincidence was not operated the background was 10-15 cpm as in a normal proportional counter. The plateaus obtained were again about 200 volts long and the operating voltage was about 1.8 kv.

The counters were operated in conjunction with an automatic recording device which allowed the decay curves to be more accurately plotted. For counting, which was always continued until the activity was too low to measure, or until a constant long-lived background was reached, the prepared sources on filter discs in aluminium planchets were mounted on aluminium trays which were then placed in the counter stand. These stands were accurately assembled so that all stands were equivalent.

The counters were calibrated as described in section (k) using a 4π -counter for absolute activity

determination. This counter is a gas-flow, β -proportional counter but it is designed for use in measuring disintegration rates. The source is mounted on a very thin support and placed inside the sensitive volume of the counter. A $4\pi\beta$ proportional counter is shown in fig. 9. The source mount is prepared from VYNS film (thickness about 10-15 $\mu\text{g. cm}^{-2}$) which is mounted on an aluminium ring 2.6 cm. in diameter and coated on one side with about 5 $\mu\text{g. cm}^{-2}$ of gold to render it conducting. To prepare a source a drop of insulin solution (containing about 1 mg./10 ml. hydrochloric acid) is spread over the central area of the film and dried. The insulin encourages spreading of the active aqueous solution which is then placed on the mount and prevents uneven deposition of the source on drying. This method of source preparation is fully described by Pate and Yaffe.⁷⁹

The electronics associated with the 4π -counter were those used with the first type of end-window counter which have been illustrated in fig. 4.

(h) Choice of Reference Element.

In most of the measurements on uranium samples ^{139}Ba was selected as the reference element. This occurs in high yield and was conveniently separated from other fission samples and from the fission fragments collected in the catcher foils.

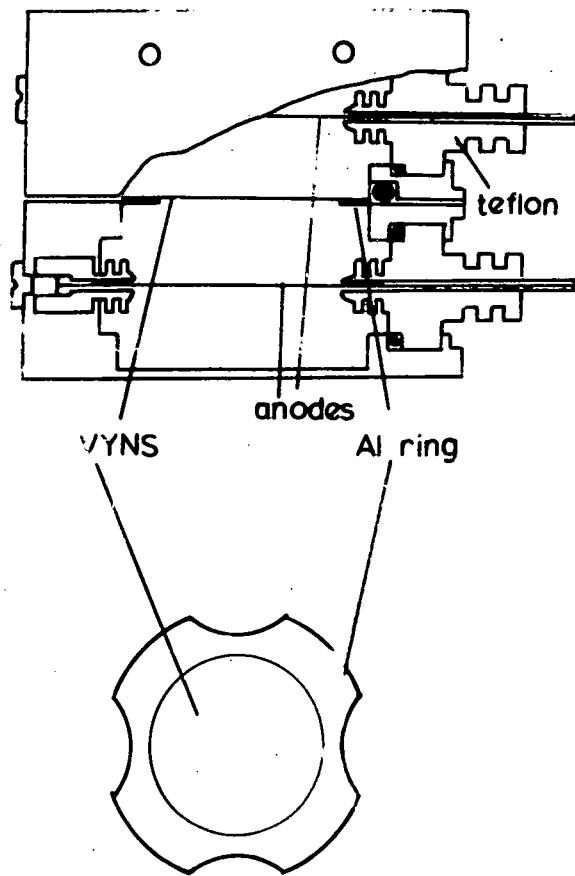

Fig. 9. 4 π counter

With protactinium, however, this nuclide could not be used. It was to be expected that some protactinium and daughter products (see fig. 10) would be transferred from the prepared samples to the catcher foils; one such daughter is ^{223}Ra with a half-life of 11.2 days. This, and its short lived daughters, would follow the barium and methods for separating radium and barium could not be carried out in the time available (the half-life of ^{139}Ba is 83 min.) Some other nuclide had therefore to be selected. It is desirable that the reference nuclide should be one which occurs in high yield in fission and which is readily separated from other fission fragments and, for this method, catcher foil material. The half-life should be long enough to allow time for a careful separation but short enough to allow the decay to be followed for a number of half-lives. It is also desirable that exchange between carrier and active species should be easily obtained. ^{97}Zr ($t_{\frac{1}{2}} = 17$ h.) fulfills these conditions, the measured activity also being increased by the presence of ^{97}Nb ($t_{\frac{1}{2}} = 72$ min.). The only uncertainty appeared to be in obtaining exchange in the presence of large amounts of catcher material but this would apply to almost any species.

(i) α -Contamination in sources from Protactinium.

The prepared protactinium samples were interleaved with

Pa		^{231}Pa			
91		$3.43 \times 10^4 \text{y}$			
Th		$\downarrow \alpha$	^{227}Th		
90			18.6d		
Ac		^{227}Ac	β_2^- (98.8%) $\downarrow \alpha$		
89		22.0y			
Ra		$\downarrow \alpha$ (1.2%)	^{223}Ra		
88			11.1d		
Fr		^{223}Fr	β^- $\downarrow \alpha$		
87		21m			
Rn		$\downarrow \alpha$ (4×10^{-3})	^{219}Rn		
86			3.92s		
At		^{219}At	β_2^- (3%) $\downarrow \alpha$	^{215}At	
85		0.9m		10^{-4}s	
Po		$\downarrow \alpha$ (97%)	^{215}Po	β_2^- (5×10^{-4}) $\downarrow \alpha$	^{211}Po
84			$1.83 \times 10^{-3} \text{s}$		0.52s
Bi		^{215}Bi	β^- $\downarrow \alpha$	^{211}Bi	β_2^- (0.32%) $\downarrow \alpha$
83		8m		2.16m	
Pb			^{211}Pb	β^- $\downarrow \alpha$ (99.68%)	^{207}Pb
82			36.1m		stable
Tl				^{207}Tl	β^-
81				4.79m	

Fig. 10. Decay series of ^{231}Pa .

aluminium foils and left for a few hours in the holder to be used for irradiations. The aluminium was then removed and counted with the end-window proportional counter set for α -counting as described in section (g). The activity on each side of each foil was found to be about 10^4 cpm; when the experiment was repeated using polystyrene foils similar results were obtained.

In the preparation of the discs each had been separately coated and therefore some of the protactinium would have been deposited on the edges which might not have been covered by the gold. The distribution of the activity was therefore investigated using several aluminium foils which had been in contact with discs for some time. These were placed in contact with photographic plates (Ilford K2 emulsion) wrapped in black paper and left for about two days. The plates were then developed in ID 19 developer solution and fixed. The autoradiographs showed that about 50-75% of the blackening was distributed in a ring corresponding to the periphery of the protactinium disc, although patches of blackening were found over the whole area which had been covered by the aluminium foil. The edges of the discs were sealed by painting on a dilute solution of polystyrene in benzene; it was estimated that the thickness applied

was less than $0.005 \text{ mg. cm.}^{-2}$ and the range of fission fragments in organic material is about 3 mg.cm^{-2} . When aluminium foils which had been in contact with these discs were autoradiographed as described above the plates showed much less blackening than before and the average counting rate on each side of the aluminium foils was reduced to about 4000 cpm. After several months of use of the Pa samples this had fallen to about 1000 cpm.

A number of experiments were carried out on the contamination of the separated fission products by protactinium. A solution of ^{233}Pa was available and since this has a characteristic gamma spectrum (peaks at 0.11 and 0.31 Mev.) the chemical procedures to be used could be checked by adding a known activity of protactinium to inactive carrier solutions, carrying out the separation and counting the protactinium activity again. Counting was done in a well-type NaI(21) scintillation counter. Tests were made on the procedures for all the fission fragments to be separated and for Br, Sr, Y, Mo, Ru, Pd, Ag and Te decontamination was $\gg 99.9\%$. When modifications were introduced into the procedures for Zr, Sb and Ce decontamination was again $\gg 99.9\%$. The procedures used, and modifications introduced are outlined in Chapter 4 and given in detail in the appendix.

When the same procedures were carried out using inactive carrier and foils which had been in contact with the protactinium samples, but not irradiated, some sources again showed an α background. (In a number of instances the most probable contaminant was ^{227}Th ($t_{1/2} = 18.6\text{d}$)). Procedures were finally worked out which reduced the background to less than 10 cpm above the normal counter background for all the elements investigated.

(j) Catcher Foil Materials Used.

It is necessary for the material to be used for catcher foils to be available as smooth foils of thickness greater than the range of fission fragments in that material. The thickness should not, however, be much in excess of this value for as the thickness of the sample irradiated increases the attenuation of the neutron beam increases; excess catcher material may also complicate the chemical separation of the fission fragments.

The materials which were used as catcher foils were aluminium (thickness = 7 mg. cm.^{-2}), polystyrene (13 mg. cm.^{-2}) and copper (44 mg. cm.^{-2}). In their investigation of radium fission Jensen and Fairhall³⁰ used aluminium foils and they state that exchange between added carrier and the active species is incomplete unless the solution of aluminium with carriers is refluxed for half

an hour with a mixture of either hydrochloric and nitric acids or sulphuric and perchloric acids or sodium hydroxide and sodium hypochlorite. For aluminium the foils were dissolved in one of these mixtures. For polystyrene the foils were dissolved in benzene in the presence of carrier solutions. In some experiments this mixture was shaken with strong acid for a few minutes but it was found that the relative yields did not agree with the values found when aluminium was used; it was thought that exchange might be incomplete. Some determinations were then made where the mixture of carriers and the benzene solution of the catcher foils was shaken with the addition of hydrochloric and hydrofluoric acids. Shaking was continued for twenty minutes and results in agreement with those from aluminium foils were then obtained. The procedure was rather inconvenient, however, and the zirconium chemical yields were reduced from 50-60% to 30-40%.

A few irradiations were carried out using copper foils and these were dissolved in concentrated nitric acid and refluxed.

(k) Calibration of the end-window counters

The end-window counters were calibrated for counting ^{91}Sr , ^{93}Y , ^{97}Zr , ^{99}Mo , ^{129}Sb and ^{143}Ce using solutions of these nuclides of high specific activity. The absolute activity (in dpm/mg) of each solution was found by the use of a $4\pi\beta$ proportional counter (described in section (f) of this chapter); any correction required to give the true disintegration rate from the counting rate in this counter is given in chapter 4 under the nuclide concerned. Solid sources of the chemical form used for counting in the relative yield determinations were then prepared from a known volume of standard carrier solution to which a known amount of the active solution had been added. The sources prepared were weighed and counted; decay curves were plotted for all sources to allow the subtraction of long-lived components. The absolute disintegration rates were calculated for these sources at a known time and the efficiency of the counters found by comparison with the observed counting rate at the same time. Graphs were then plotted of the efficiency of the counter against source weight; these are also given in chapter 4.

The solutions used for ^{91}Sr , ^{93}Y , ^{97}Zr , and ^{129}Sb were obtained from uranium dioxide irradiated in a reactor for one day in a thermal neutron flux of $10^{12}\text{ n cm}^{-2}\text{ s}^{-1}$. These were separated using the methods given in the appendix but reduced for working with 1 mg. of carrier. ^{99}Mo was

obtained by a similar irradiation of molybdenum oxide and ^{99m}Tc separated from it by dry distillation. ^{143}Ce was produced by the irradiation of a sample of cerous oxide.

For the remaining nuclides (that is, ^{83}Br , ^{105}Ru , ^{112}Ag , ^{113}Ag and ^{132}Te) the efficiencies were calculated using the method of Bayhurst and Prestwood.⁸⁰ In this procedure solutions of a number of nuclides which decay by the emission of one β group are standardised (in the present case by 4π counting) and a range of solid sources prepared. The efficiency is then calculated as above and graphs of efficiency against source weight plotted. The average β energy of each nuclide is calculated using the known maximum energy and a series of graphs given in the original paper.⁸⁰ Curves are plotted, for a number of sample weights, of counter efficiency against average β energy and the efficiency of any nuclide for which the maximum β energy is known can then be found. For nuclides emitting more than one β group the efficiency is found for each group and a weighted mean calculated; this requires a knowledge of the abundance of the various groups. It is also necessary to know the shape of the spectrum since a correction must be made for any first forbidden transitions.

Measurements were made using ^{45}Ca , ^{185}W , ^{90}Y , ^{91}Y , ^{22}Na , ^{24}Na and ^{42}K ; two of the curves of efficiency against average

energy (for 5mg. and 30mg. source weight) are shown in fig. 11 and the curves of efficiency against source weight calculated for the various nuclides are given in the appropriate sections of chapter 4. Calculations were made of the efficiencies for those nuclides for which experimental measurements had also been made; the agreement was found to be within 2-3%.

The efficiency of the counter could also be calculated for nuclides in transient equilibrium.

$1 \xrightarrow{\lambda_1} 2 \xrightarrow{\lambda_2} 3$ (stable). (1 and 2 are nuclides in transient equilibrium).

The appropriate efficiency factor (η_1) of the parent in such a system is given by

$$\eta_1 = \frac{I_1 + I_2}{A_1}$$

where I_1 and I_2 are the observed counting rates of 1 and 2 and A_1 is the absolute activity of 1.

$$\therefore \eta_1 = \frac{\eta'_1 A_1 + \eta'_2 A_2}{A_1}$$

since $\eta = \frac{I}{A}$. η'_1 and η'_2 are the efficiencies for 1 and 2 alone.

$$= \eta'_1 + \eta'_2 \frac{A_2}{A_1}$$

Since 1 and 2 are in transient equilibrium,

$$\frac{A_2}{A_1} = \frac{\lambda_2}{\lambda_2 - \lambda_1}$$

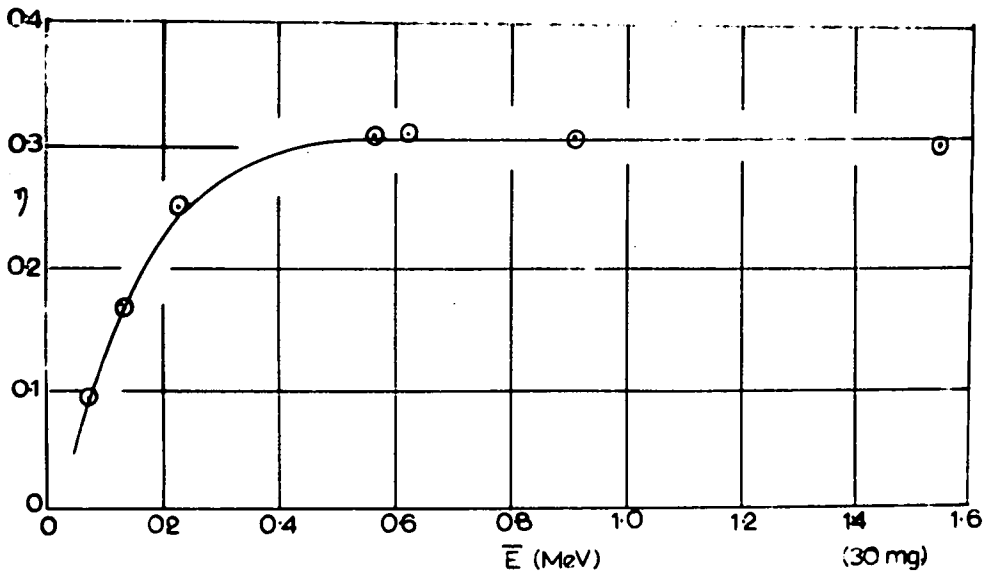
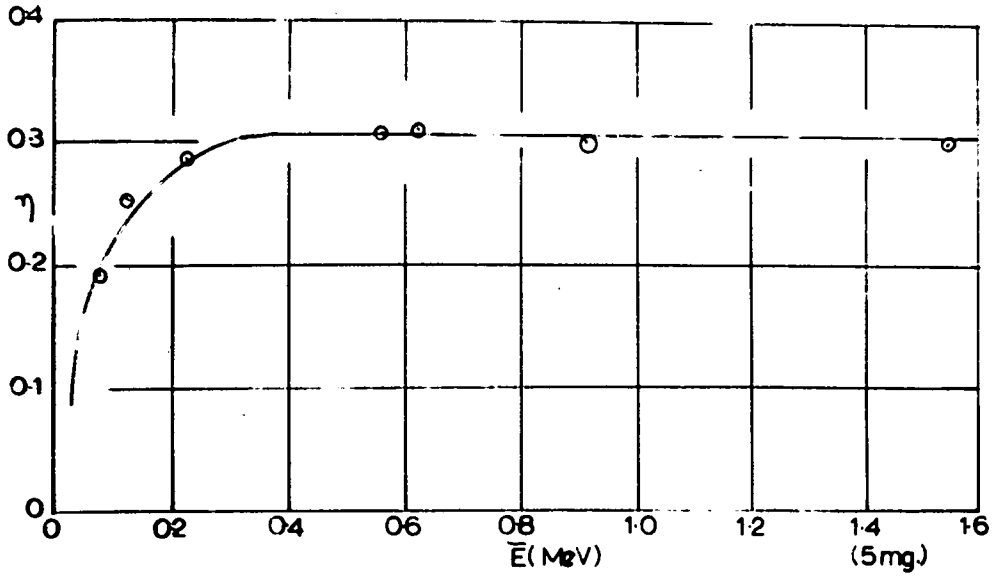

Fig.11. Graphs of efficiency against average β energy.

$$\therefore \eta_1 = \eta'_1 + \eta'_2 \left(\frac{\lambda_2}{\lambda_2 - \lambda_1} \right)$$

η'_1 and η'_2 were found in the usual way from the curves of efficiency against energy.

CHAPTER 3Measurement of Relative Yields from the Fission of Uranium

In order to check the validity of the methods developed, before commencing work on protactinium, measurements were made on the relative yields of ^{97}Zr and ^{113}Ag in the fission of ^{238}U with 14 Mev neutrons using ^{139}Ba as the reference element. During the course of the investigations of relative yields from protactinium a few determinations were also made of the relative yields from uranium of ^{105}Ru and ^{99}Mo , using ^{97}Zr as the reference element.

In this chapter an outline of the general method of treatment of the radiochemical data is given together with the chemical methods used in, and results obtained from, the measurements on uranium fission. The applicability of the methods used in investigations of the fission of protactinium is also discussed.

(a) General Treatment of Results.

When solid sources were separated the decay was followed to enable the curves to be resolved, giving the decay of the nuclide of interest. These activities were then extrapolated back to the activity at the end of the irradiation. The count rates so obtained were corrected for the chemical yields of the species and compared with the similarly corrected

activity of the reference nuclide. Corrections were made for the presence of any daughter activities and also for the variations in the neutron flux during the irradiation. This was done as follows:-

Consider an irradiation of duration T , and assume that a fission fragment is isolated at time t' after the end of the irradiation.

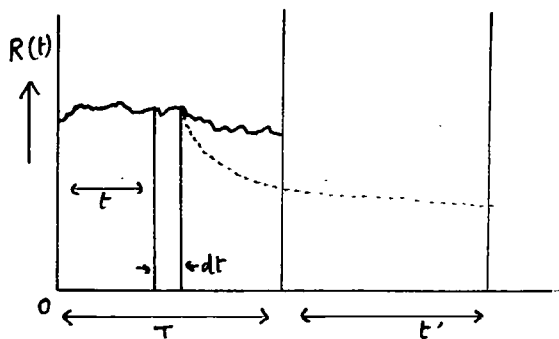

It is also assumed that the precursors of this nuclide (1) are short lived compared with T and t' .

Nuclide 1 is produced throughout the irradiation at an irregular rate $R(t)$ where R is some function of t . In the interval dt the number of nuclei produced will be:-

$$dN_1 = R(t).dt.$$

These nuclei will then decay exponentially and at t' the number remaining will be

$$\begin{aligned} dN_1(t') &= R(t) e^{-\lambda_1(t' + (T-t))} dt. \\ &= e^{-\lambda_1 t'} .R(t) e^{-\lambda_1(T-t)} .dt. \end{aligned}$$

The total number of nuclei of nuclide 1 present at time t' will therefore be

$$N_1(t') = e^{-\lambda_1 t'} \int_{t=0}^{t=T} R(t) e^{-\lambda_1 (T-t)} dt.$$

Now, $R(t) = B \cdot \sigma \cdot Y_1 \cdot \phi(t)$

where, B = some constant for the particular irradiation

σ = fission cross-section.

Y_1 = fission yield of nuclide 1.

$\phi(t)$ = neutron flux.

But the variation in $\phi(t)$ is proportional to the variation in $I(t)$ the neutron monitor reading.

Then $R(t) = B \cdot \sigma \cdot Y_1 \cdot I(t) / \eta$ where η = efficiency of the monitor.

$$\therefore N_1(t') = \frac{B \cdot \sigma \cdot Y_1}{\eta} e^{-\lambda_1 t'} \int_{t=0}^{t=T} I(t) e^{-\lambda_1 (T-t)} dt.$$

When the time intervals taken are much shorter than the half-life of the species concerned the integral may be replaced by the summation

$$\sum_{t=0}^{t=T} I e^{-\lambda_1 (T-t)} \delta t \dots \dots \dots (S_1)$$

which may be evaluated from a knowledge of the monitor readings.

When the yield of nuclide 1 is compared with the yield of the reference nuclide r (for which similar expressions may be deduced)

$$\frac{N_1}{N_r} = \frac{Y_1 \cdot e^{-\lambda_1 t'} \cdot S_1}{Y_r \cdot e^{-\lambda_r t''} \cdot S_r}$$

From the decay curves values A_1^0 and A_r^0 (the activities of 1 and r at the end of the irradiation) are read off. At this point $t' = t'' = 0$, and since $A = c\lambda N$ (where c is the detection coefficient for a nuclide)

$$\frac{A_1^0}{A_r^0} = \frac{c \cdot \lambda_1 \cdot Y_1 \cdot S_1}{c_r \cdot \lambda_r \cdot Y_r \cdot S_r}$$

It is assumed in the above that the precursors of the fission product under consideration have negligible half-lives with respect to that of the daughter. If this is not the case the treatment must be modified.

Considering the chain (short) $\longrightarrow 1 \xrightarrow{\lambda_1} 2 \xrightarrow{\lambda_2} 3$ (stable)
Assuming 2 are formed only from 1 the number of nuclei of 2 present at t' is

$$N_2(t') = \frac{\lambda_1}{\lambda_2 - \lambda_1} \left[e^{-\lambda_1 t'} \int_{t=0}^{t=T} R(t) e^{-\lambda_1(T-t)} \cdot dt - e^{-\lambda_2 t'} \int_{t=0}^{t=T} R(t) e^{-\lambda_2(T-t)} \cdot dt \right]$$

and, on replacing integrals by summations,

$$N_2(t') = \frac{B \cdot \sigma \cdot Y_1}{\eta} \cdot \frac{\lambda_1}{\lambda_2 - \lambda_1} (e^{-\lambda_1 t'} \cdot S_1 - e^{-\lambda_2 t'} \cdot S_2)$$

If t' is long compared with the half-life of 1 this becomes

$$N_2(t') = \frac{B \cdot \sigma \cdot Y_1}{\eta} \cdot \frac{\lambda_1}{\lambda_2 - \lambda_1} \cdot S_2 e^{-\lambda_2 t'}$$

$$\therefore N_2^0 = \frac{N_2(t')}{e^{-\lambda_2 t'}} = \frac{B \cdot \sigma \cdot Y_1}{\eta} \cdot \frac{\lambda_1}{\lambda_1 - \lambda_2} \cdot S_2$$

On conversion to activity at the end of the irradiation and comparison with the reference nuclide activity this becomes

$$\frac{A_1^0}{A_R^0} = \frac{c_1 \cdot Y_1 \cdot S_1 \cdot \lambda_1}{c_R \cdot Y_R \cdot S_R \cdot \lambda_R} \cdot \frac{\lambda_1}{\lambda_1 - \lambda_2}$$

This expression is required for a discussion of the results from ^{139}Ba .

It can be seen that in the expressions for the relative activities the factor c appears; this is the efficiency of the counter for the nuclide under consideration and is compounded from various corrections for scattering, self-absorption, back-scattering and any other losses as well as for the intrinsic efficiency of the counter itself. These are ignored in the present measurements since the aim was to compare relative yields determined under different conditions but where the counting techniques were identical.

(b) Relative Yields of Nuclides Investigated.

The reason for the choice of ^{139}Ba and ^{97}Zr as reference elements has been discussed previously (Chapter 2, section 6);

in this section an account is given of the separation of three nuclides from irradiated uranium samples and of the relative yields measured.

(1) Barium

83m ^{139}Ba was separated from almost all the irradiations.

The decay scheme for mass 139 is:-

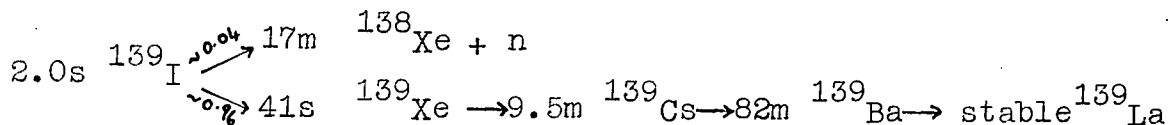

Since barium is formed by the decay of 9.5m cesium the chemical separation was never begun until ninety minutes after the end of the irradiation to allow the parent species to decay. The half-life of the parent is not negligible with respect to that of the daughter and therefore a correction must be made to allow for the decay of the parent. The modified expression for the relative yield has been set out in the previous section. For this decay chain the factor

$$\frac{\lambda_1 - \lambda_2}{\lambda_1} = \frac{t_2 - t_1}{t_2} = \frac{85 - 9.5}{85} = 0.8882$$

The barium was separated by the method recommended by Sunderman⁸ which consists of a series of precipitations of $\text{BaCl}_2 \cdot \text{H}_2\text{O}$ from HCl-ether reagent. (The procedure, together with the preparation of the carrier solution used, is given in full in the appendix).

The sources prepared decayed to a low-level, long-lived, back-ground activity but ^{the decay curves} were always readily resolved to give the component with the expected 83m half-life.

The results obtained from catcher foils and oxide samples are given in Tables 1 and 2.

(2) Zirconium

⁹⁷Zr was separated in almost every irradiation. The decay chain for this mass is:-

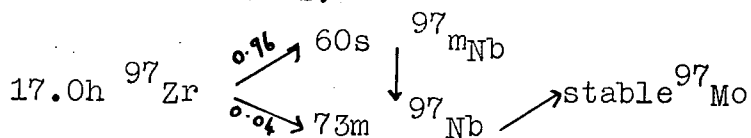

The activity of a zirconium source first increases as ⁹⁷Nb grows in and then decays with the expected 17h. half-life of ⁹⁷Zr. Any long lived background was always very small.

In the expression for the relative yield a correction was made to the zirconium count rate to allow for the contribution of ⁹⁷Nb to the count rate: 60s ^{97m}Nb which decays entirely to ⁹⁷Nb could be neglected.

If ⁹⁷Zr = 1 and ⁹⁷Nb = 2, then, at transient equilibrium,

$$\frac{A_1}{A_2} = \frac{\lambda_2 - \lambda_1}{\lambda_2} = \frac{0.5619 - 0.04078}{0.5619} = 0.9276 \quad (\text{assuming equal detection coefficients})$$

$$\text{The observed activity, } A = A_1 + A_2 = A_1(1 + 1/0.9276) = 2.078A_1$$

$$\therefore A_1 = A/2.078$$

TABLE 1

Run	I°obs.	I°corr.	S _p x10 ⁴	%	foil	Direction of collection *
1	480	889	35.85	53.946	Al	F
2	490	685	2.11	71.497	Al	F
3	480	1010	4.27	47.532	Al	F
4	425	840	50.50	50.565	Al	F
5	210	462	23.01	45.444	Al	B
6	365	539	34.22	67.669	Al	B
7	285	469	22.85	60.708	Al	B
8	175	237	12.85	73.934	ps	B
9	140	177	19.72	79.303	Ps	B
10	70	88	14.55	79.353	PS	-
11	112	150	29.45	74.928	PS	F
12	100	130	11.21	77.000	PS	F
13	198	518	47.42	38.216	Al	F
14	50	190	21.00	26.287	Cu	F
15	335	1020	107.7	32.826	Cu	F
16	4150	7339	74.13	56.550	Al	-
17	2300	4250	49.66	54.121	Al	-
18	1400	3104	45.18	45.064	Al	-
19	690	880	22.42	78.375	PS	-
20	1100	1433	39.87	76.785	PS	-
21	2800	3345	65.12	83.721	PS	-
22	2200	4360	206.9	50.463	CuO	-

TABLE 1 (continued)

Run	I ^o obs.	I ^o corr.	S _r x 10 ⁴	%	foil	Direction of collection
23	1550	3003	55.69	51.617	CuO	-
24	1450	5472	358.9	26.501	C.NO ₃	-

* F-fission fragments collected in the forward direction only

B-fission fragments collected in the backward direction only.

Results of measurements on ¹³⁹Ba (using catcher foils).

TABLE 2

Run	$I^{\circ}_{\text{obs.}}$	$I^{\circ}_{\text{corr.}}$	Sr x 10^4	%
1	7800	11443	35.89	68.166
3	1400	8331	4.27	16.805
4	4200	9283	50.50	45.245
6	5150	6910	34.22	74.530
7	3040	4727	22.85	66.426
13	1820	4149	47.42	43.871
15	7400	11600	107.7	63.800
16	6000	10488	74.12	57.213
17	5050	9331	49.66	54.121
18	1250	2212	45.18	56.462
19	2300	5727	22.42	40.160
20	5300	6902	39.87	76.785
21	10000	18063	65.12	55.358
24	125000	26427	358.9	47.327
25	12000	24145	297.0	49.69

Results of measurements on ^{139}Ba (using oxide or nitrate samples).

Zirconium was first precipitated as the hydroxide and purified using the procedure of Hahn and Skomieczny⁸² which consists of a precipitation of the zirconium with mandelic acid followed by LaF_3 scavenges, a series of barium fluorozirconate precipitations and a zirconium hydroxide precipitation. A final precipitation of the Zr as tetramandellate was used to prepare the source. The procedure is given in detail in the appendix, together with the preparation and standardisation of the carrier solution.

The results obtained from the various irradiations are given in Tables 3 and 4.

(3) Silver

5.3h ^{113}Ag was separated; the decay chain for this mass is:-

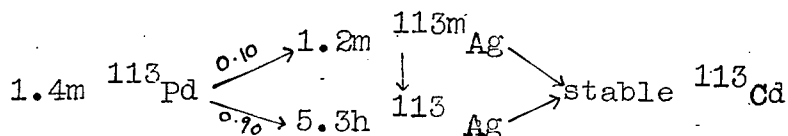

The samples were left for 14 minutes before the separations were carried out to allow the decay of 1.4m Pd and 1.2m Ag to 5.3h ^{113}Ag .

Silver was first precipitated as the chloride and then purified by a sequence of precipitations with benzotriazole, and as chloride, interspersed with iron scavenges. Finally the silver was precipitated as the hydrated oxide and then

TABLE 3

Run	$I_{\text{obs.}}^{\circ}$	$I_{\text{corr.}}^{\circ}$	$Sx10^4$	$Srx10^4$	%	foil	Dir. of Coll.	Zr/Ba
1	88	214	48.54	35.89	41.029	Al	F	1.10
2	120	151	2.62	2.11	79.456	Al	F	1.17
3	92	215	5.31	4.27	42.813	Al	F	1.13
4	62	199	62.84	50.50	31.167	Al	F	1.14
5	40	116	31.37	23.01	34.505	Al	B	1.21
6	62	123	44.11	34.22	50.247	Al	B	1.17
7	38	171	28.82	22.85	22.239	Al	B	1.10
8	22	34	19.06	12.85	64.367	PS	B	0.64
9	32	50	23.77	19.72	64.595	PS	B	1.54
10	18	29	22.77	14.55	61.798	PS	-	1.31
11	20	30	35.29	29.45	67.260	PS	F	1.15
12m	24	33	14.13	11.21	72.230	PS	F	0.96
13	62	105	58.25	47.42	59.040	Al	F	1.09
14	23	44	26.72	21.00	52.296	Cu	F	1.20
15	140	202	135.7	107.7	69.193	Cu	F	1.04
16	900	1356	86.01	74.13	66.360	Al	-	1.05
17	520	784	58.21	49.66	66.310	Al	-	1.00
19	145	192	28.30	22.42	75.360	PS	-	1.14
20	175	270	46.42	39.87	64.580	PS	-	1.07
21	550	668	75.07	65.12	82.305	PS	-	1.14
22	405	983	280.1	206.9	41.215	CuS	-	1.10
23	385	613	69.90	55.69	62.800	Cu	-	1.07

Measurements of the relative yield of ^{97}Zr (using catcher foils).

TABLE 4

Run	I_{O} obs.	I_{O} obs.	S_4 $\times 10^4$	Sr_4 $\times 10^4$	%	Zr/Ba
1	2000	2800	48.85	35.89	70.339	1.20
3	1025	1900	5.31	4.27	53.815	1.21
4	1590	2331	62.84	50.50	68.203	1.33
6	1500	1865	44.11	34.21	80.417	1.35
7	820	1092	28.82	22.85	75.117	1.25
13	830	1001	58.25	47.42	82.957	1.30
15	1520	2396	135.7	107.7	63.427	1.09
16	1500	2039	86.01	74.13	73.555	1.11
17	1380	1846	58.21	49.66	74.734	1.10
19	940	1283	28.30	22.42	73.280	1.17
20	1500	2024	46.42	39.87	74.132	1.17

Measurements of the relative yield of ^{97}Zr (using samples
of oxide or nitrate).

mounted for counting as the iodate. This procedure, and the preparation of the carrier solution are described in the appendix.

The results for the yield of silver relative to barium are given in Tables 5 and 6.

TABLE 5

Run	$I_{\text{obs.}}^{\circ}$	$I_{\text{corr.}}^{\circ}$	%	Sr x 10^4	S x 10^4	foils	Ag/Ba
18	25	97	25.810	45.18	54.77	Al	0.11
24	50	216	23.228	358.9	524.7	C.NO ₃	0.14
25	88	261	33.736	297.0	365.0	C.NO ₃	0.18
26	52	442	11.7640	114.8	109.3	Al	0.17*

* Measured relative to ^{97}Zr

Measurements of the relative yield of ^{113}Ag (using catcher foils).

TABLE 6

Run	$I_{\text{obs.}}^{\circ}$	$I_{\text{corr.}}^{\circ}$	%	Sr x 10^4	S x 10^4	Ag/Ba
18	81	130	62.274	45.18	54.77	0.21
24	1020	1541	66.241	358.9	524.7	0.17
25	730	1011	72.160	297.0	365.0	0.15

Measurements of the relative yield of ^{113}Ag (using uranyl nitrate samples).

(4) Ruthenium, and Molybdenum

Two determinations of the yield of ^{105}Ru and one of ^{99}Mo were made relative to ^{97}Zr . Aluminium catcher foils were used and a sample of oxide or nitrate was not irradiated. These experiments were performed to test the chemical procedures used in the protactinium work and the results are reported in Chapter 4.

(c) Discussion

Using ^{the prepared foils} twenty three determinations of the yield of ^{97}Zr were made relative to that of ^{139}Ba ; ~~the prepared uranium targets~~ in eleven of the experiments a sample of uranium oxide or uranyl nitrate was irradiated at the same time and the relative yield of ^{97}Zr again determined. The following are the average values for these relative yields:-

$$^{97}\text{Zr}/^{139}\text{Ba} \text{ (foils)} = 1.11 \pm 0.16 \text{ (23 determinations)}$$

$$^{97}\text{Zr}/^{139}\text{Ba} \text{ (oxide)} = 1.20 \pm 0.09 \text{ (11 determinations)}$$

The yield of ^{97}Zr relative to ^{139}Ba has been previously found to be 1.21 ± 0.07 and the measurements on oxide samples give a value, with a low standard deviation, which is in reasonable agreement with this; the recoil experiments, however, give an average value which has a large standard deviation and which is about 6% lower than the published value.

Some possible sources of error in the use of a recoil method have been mentioned in Chapter 1. Discrepancies arising from differences in range in the fragments would be expected to lead to a high value for this ratio since it has been demonstrated⁶⁵ that the range of the light fragments is greater than the range of the heavier fragments in a number of fissioning systems. It would therefore seem that, while this effect must exist, it is not the cause of the difference between the values.

It has also been observed^{64,83,84} that the degree of anisotropy is different for the different fission products in the fission of thorium, and a number of uranium isotopes, with 22 Mev protons. If it is assumed that the distributions of individual fission fragments are similar for neutron induced fission the greatest degree of anisotropy may be expected for nuclides produced in asymmetric fission. This is the case for ⁹⁷Zr and ¹³⁹Ba but they are near complementary fragments and therefore this effect might be expected to cancel.

Any nuclides with half-lives similar to those of the fission products investigated which are produced by activation of the materials used in the prepared samples or catcher foils and carried through the separation procedures could also give rise to discrepancies. The only species produced in this

way which have half-lives comparable with those being measured are 18 hour ^{197}Pt and 19 hour ^{194}Ir (formed by several possible reactions on gold or platinum) or 15.4 hour ^{24}Na (from aluminium). These, however, could only be confused with 17 hour ^{97}Zr and in this case would give rise to high, rather than low, values for the relative yields.

A further possibility considered is that exchange between the carrier solutions and the fission fragments produced is incomplete. As a check experiments were carried out using several different materials for catcher foils. The values for the relative yields of ^{97}Zr were:-

Al foils (10 determinations) 1.11 ± 0.06

Cu foils (3 determinations) 1.10 ± 0.07

Polystyrene foils (8 determinations) 1.12 ± 0.24

It can be seen that the error in the values found using polystyrene foils is considerably greater than in the values found using copper or aluminium which suggests that in this case exchange is indeed incomplete a conclusion also indicated by some experiments carried out using the protactinium discs and aluminium foils where the value for the relative yield of ^{113}Ag was about twice that obtained using polystyrene for collection of the fragments. (These experiments are described in Chapter 4). If the values

found from irradiations using polystyrene foils are neglected the average relative yield value is:-

$${}^{97}\text{Zr}/{}^{139}\text{Ba} \text{ (foils)} = 1.11 \pm 0.06 \text{ (13 determinations)}$$

The standard deviation is now reduced and although the value is still low compared with that published, it is more nearly comparable with that determined using bulk samples irradiated under the same conditions as the prepared target discs. (In neither case were any corrections made for counter efficiencies and therefore exact agreement with the corrected, published figures is not to be expected).

When the average values for the relative yields measured using the prepared target discs is divided by that measured using bulk samples,

$$\frac{{}^{97}\text{Zr}/{}^{139}\text{Ba} \text{ (foils)}}{{}^{97}\text{Zr}/{}^{139}\text{Ba} \text{ (oxide)}} = 0.92 \pm 0.12$$

Thus, any discrepancy falls within the standard deviation of the values.

A further observation may be made on these values since the first set of prepared targets allowed collection of the fission fragments from one side only and the ratio of forward to backward recoils can therefore be calculated,

Backwards 1.16 ± 0.04 (3 determinations)

Forwards 1.13 ± 0.03 (5 determinations)

Backwards/forwards = 1.03 ± 0.07

These values are in agreement, as would be expected from the recorded data on the anisotropic distribution of fission fragments.⁶⁴

A few determinations were also made of the yield of ^{113}Ag relative to ^{139}Ba ; the values do not show any marked discrepancy.

$^{113}\text{Ag}/^{139}\text{Ba}$ (foils) = 0.14 ± 0.04 (3 determinations)

$^{113}\text{Ag}/^{139}\text{Ba}$ (oxide) = 0.18 ± 0.03 (3 determinations)

This would indicate that differences in anisotropic distribution have little effect on the observed ratios for if the degree of anisotropy of the fission fragments is similar to those observed in the proton induced fission of uranium, then in a ratio such as silver to barium where one fragment is formed in symmetric fission and one in asymmetric, the difference in anisotropy would be greatest.

It therefore appears that a recoil method gives reasonably satisfactory results in the determination of fission yields for ^{238}U . If it is then applied to protactinium for which values of the fission yields are not known it is necessary to assume that for the two systems

the factors just discussed carry equal weight.

Halpern⁸³ has reviewed the investigations which have been made into the angular distributions of fission fragments; he concludes that the degree of anisotropy decreases as the value of Z^2/A of the target nuclei increases. It has been suggested⁸⁵ that this trend is merely fortuitous but it appears to hold for nuclides from ^{226}Ra to ^{139}Pu . For ^{238}U , $Z^2/A = 35.56$ and for ^{231}Pa , $Z^2/A = 35.85$; this would indicate that the expected degree of anisotropy would be less for ^{231}Pa than for ^{238}U . The angular distributions of the individual fission fragments have been measured for the proton induced fission of ^{232}Th ,⁶⁴ and a number of uranium isotopes,⁸⁴ and found to have a rather similar dependence on mass number for each nuclide. If this may be assumed to apply to neutron induced fission over a similar range of mass of the fissioning nucleus it could appear that the distributions of the fragments would not be greatly different for the fission of ^{231}Pa and ^{238}U .

The ranges of fission fragments have also been measured⁶⁵ for a number of fissioning systems and found to be similar.

It would therefore seem that discrepancies introduced by the use of a recoil method should not be greatly different

for protactinium and uranium. Results in fair agreement with those found using the technique of irradiation of bulk samples have been obtained for ^{238}U ; it therefore seems reasonable to apply this method to an investigation of relative yields from the fission of ^{231}Pa .

CHAPTER 4

Measurements of relative yields from the fission of protactinium

In fission a wide range of nuclides are produced but the number which can be measured by radiochemical methods is limited. Measurements cannot be made when the level of activity is low; this may arise because the fission yield is low, or because the half-life of the specific nuclide is long. In the present work about 150 mg. of protactinium was irradiated in a flux of about 10^9 n/sec. and isotopes with half-lives greater than 3 days were not separated for the purpose of measurement. A further restriction on the selection of nuclides for measurement is that in some chains the decay schemes are complex,¹⁶ or not known with certainty. These chains predominate in the symmetric fission region.

The arrangements for irradiation, source preparation and counting have been described in Chapter 2, and the treatment of the results outlined in Chapter 3. It was also necessary to make corrections for the efficiency of the counters for the various nuclides selected; the methods used are described in Chapter 2.

A list of nuclides on which measurements have been made is given in table 7 together with the values used for the half-lives. The compilation of Katcoff¹⁶ was used as a

source of information on decay chains with reference where applicable to the Nuclear Data Sheets ⁸⁶ for more recent information on specific nuclides.

When the relative yields had been calculated they were corrected to total chain yields and a mass-yield curve plotted. These calculations are discussed in Chapter 5.

TABLE 7

Mass No.	Nuclides measured.
84	31.6 minute ⁸⁴ Br
91	9.7 hour ⁹¹ Sr
93	10.3 hour ⁹³ Y
97	17 hour ⁹⁷ Zr
99	67 hour ⁹⁹ Mo
105	4.45 hour ¹⁰⁵ Ru
112	21 hour ¹¹² Pd/3.2 hour ¹¹² Ag
113	5.3 hour ¹¹³ Ag
129	4.6 hour ¹²⁹ Sb/72minute ¹²⁹ Te
132	77 hour ¹³² Te/2.3 hour ¹³² I
143	33 hour ¹⁴³ Ce.

Nuclides measured in the investigation of the fission of

²³¹Pa with 14 MeV neutrons.

Measurements of Relative Yields

(1) Zirconium (Reference element)

The decay chain for mass 97 has been given in Chapter 3 (page 58). Other zirconium species are either longer or shorter lived (1.1×10^6 y ^{93}Zr , 65 d ^{95}Zr and 30 s ^{99}Zr) and would not be confused with ^{97}Zr .

Zirconium was separated from each irradiation carried out and the decay curves showed the initial increase as ^{97}Nb grew in followed by the expected 17h decay of zirconium. Sometimes a long lived background activity was observed but this was small and the curves were easily resolved.

The chemical procedure used was essentially that of Hahn and Skomiczmy⁸² which was outlined in Chapter 3 but tests with ^{233}Pa tracer showed that decontamination was only about 50% if the procedure was used without modification. This was increased to better than 99% by the inclusion of an extraction of a concentrated hydrochloric acid solution of the zirconium fraction with di-isobutyl ketone. Two extractions gave 99.9% decontamination; the loss of zirconium incurred was not greater than 10%. Since zirconium was separated from all irradiations aluminium, copper and polystyrene foils were used; from aluminium or copper it was first precipitated as hydroxide with the addition of excess sodium or ammonium hydroxide. From polystyrene the solution used to extract the active species contained fluoride

(see under silver page 84) and the zirconium was first precipitated as barium zirconyl fluoride.

The chemical procedure used and the preparation and standardisation of the carrier solution are described in the appendix.

Calibration of the end-window counter for ^{97}Zr .

A solution of high specific activity ^{97}Zr (about 10^6 dpm/mg of zirconium) was separated from a sample of uranium irradiated in a nuclear reactor and the efficiency for a number of source weights determined as described in Chapter 2, section (k).

In order to calculate the absolute activity of ^{97}Zr from the observed count rate of the 4π sources it was necessary to make corrections for the presence of $60\text{ s. }^{97\text{m}}\text{Nb}$ and $72\text{m. }^{97}\text{Nb}$. $^{97\text{m}}\text{Nb}$ decays by γ -emission with 1.5% conversion; these conversion electrons will be counted in the 4π counter though not with the end-window counter. The efficiency of the 4π counter for γ rays will be about 1% and therefore the observed counting rate must be divided by 1.025 to correct for the presence of $^{97\text{m}}\text{Nb}$. The correction for the presence of ^{97}Nb has been calculated in Chapter 3; it is necessary to divide the observed counting rate by 2.078.

A curve of efficiency against count rate is given in

fig. 12 and the results of measurements on ^{97}Zr are shown in table 8 where I° corr. is the activity of the zirconium at the end of the irradiation (I° obs.) after correction for counter efficiency (γ) and chemical yield. S_{Zr} values were calculated from the neutron monitor readings taken throughout the irradiation. I° corr. and S_{Zr} were used in calculations of the relative yields of other nuclides.

(2) Bromine

32 minute ^{84}Br was the nuclide measured; the decay chain for mass number 84 is:

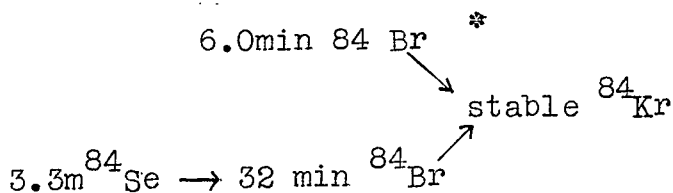

2.4 hour ^{83}Br was always observed in the decay of the sources but the relative yield of this nuclide was not calculated since an appreciable proportion is produced by the decay of 25 minute ^{83}Se . The decay curves observed could always be readily resolved and the initial activity of ^{84}Br measured. Any long lived background was always low.

Bromine was separated from irradiations where aluminium

* A 6 minute isotope of bromine has been observed and was previously attributed to ^{84}Br ; ⁸⁷ recent work ¹¹⁵ suggests, however, that it should perhaps be assigned to $^{82\text{m}}\text{Br}$. A six minute species would not have been observed in the present work.

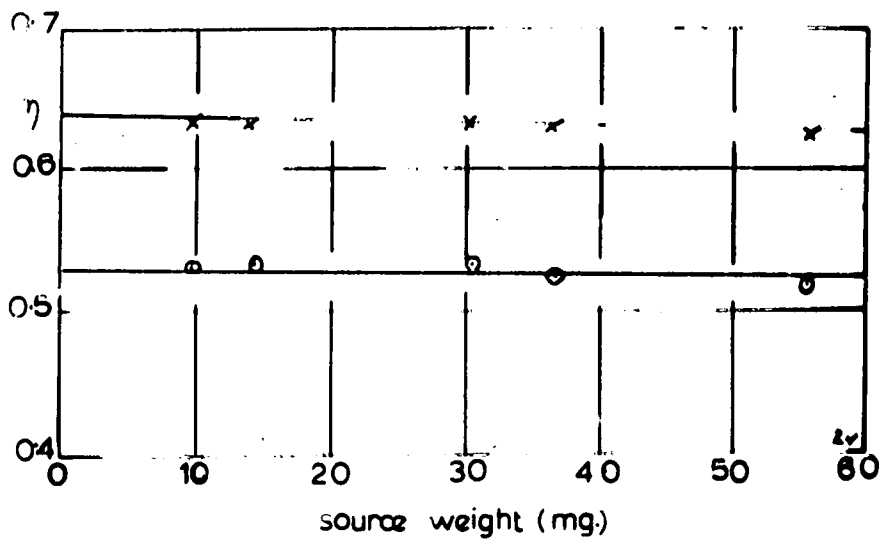

Fig.12. Counter efficiency against source
 97
 weight for Zr.

TABLE 8

Results for the reference nuclide - 17h, ^{97}Zr

Run	foil	source wt. mg.	Chemical yield %	η	$I^{\circ}_{\text{obs.}}$	$I^{\circ}_{\text{corr.}}$	$S \times 10^6$
1	Al	40.82	55.72	0.631	1220	3470	1.635
2	Al	42.40	57.88	0.631	640	1752	1.029
3	Al	36.37	49.65	0.634	850	2701	1.506
4	PS	27.90	39.53	0.635	410	1633	1.670
5	PS	15.82	22.42	0.636	275	1929	1.332
6	Al	31.13	44.11	0.527	740	3183	1.154
7	Al	39.13	55.45	0.632	3300	9431	3.522
				0.525	2750		
8	Al	44.49	63.04	0.631	1200	3060	1.232
				0.525	1025		
9	Al	17.54	24.85	0.636	550	3480	1.548
10	Al	39.28	55.66	0.632	1275	3545	1.276
				0.525	1025		
11	Al	20.66	29.28	0.636	540	2900	1.380
12	Al	7.30	10.34	0.532	157	2854	1.115
13	Al	34.49	48.87	0.525	370	1441	0.850
14	Al	36.00	51.01	0.525	285	1064	0.731
15	Cu	16.78	23.78	0.530	255	2022	0.909
16	Cu	17.98	25.48	0.636	255	1572	0.859
17	Cu	10.70	15.16	0.531	168	2087	0.892
18	Al	31.40	44.49	0.527	560	2388	1.360
19	Al	26.73	37.88	0.529	880	4392	1.997
20	Al	33.86	53.06	0.625	235	709	1.071
21	Al	14.57	22.83	0.630	41	285	1.289
22	Al	26.97	42.26	0.630	510	1916	1.449
25	Al	23.30	36.51	0.635	1850	7980	5.659
26	Al	6.65	10.90	0.640	670	10047	6.7210
27	Al	50.23	78.71	0.630	2700	5445	3.659
28	Al	13.70	22.45	0.630	730	5161	3.786
29	Al	7.32	12.00	0.635	860	11286	11.955

catcher foils were used; these were first dissolved in the minimum of concentrated caustic soda and the solution cooled in an ice-bath. It was next cautiously acidified with hydrochloric and nitric acid without allowing the temperature to rise. In one irradiation bromine was extracted into carbon tetrachloride after oxidation with 1M potassium permanganate but in the others it was separated by the distillation method of Sattizahn.⁸⁷ The bromine was then purified using the method of Glendenin⁸⁸ as modified by Ramaniah⁸⁹ (tests with ^{233}Pa solution showed that decontamination was $> 99.9\%$) which involves the addition of iodine carrier and its extraction into carbon tetrachloride followed by further oxidations and extractions of bromine with a final precipitation of silver bromide for yield determination and counting. The procedure is given in full in the appendix together with details of the preparation of the carrier solution used.

Calibration of the end-window counter

The efficiency of the end window counter for a number of source weights was calculated from the Bayhurst curves⁸⁰ as described in Chapter 2, section (k); a graph of efficiency is given in fig. 13 and the results of the relative yield measurements in table 9.

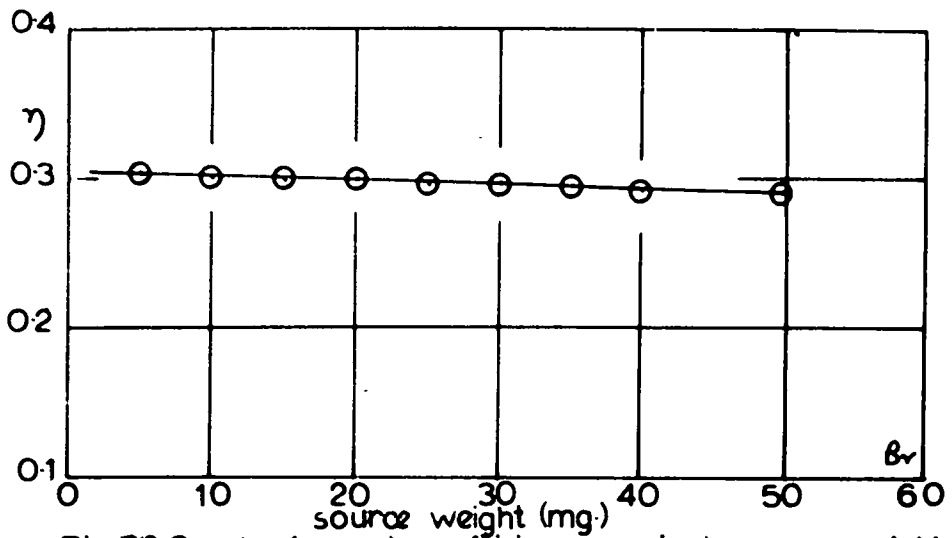

Fig. 1.3 Graph of counter efficiency against source weight for ^{82}Br .

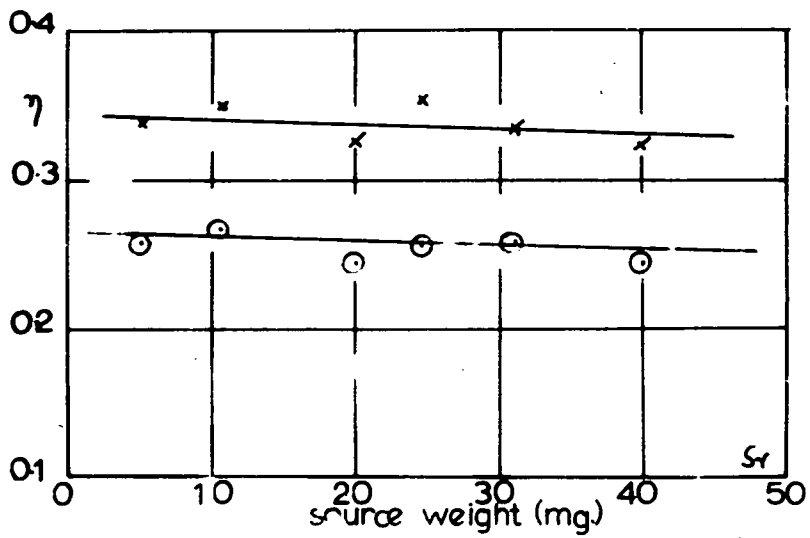

Fig. 1.4. Graph of counter efficiencies against source weight for ^{91}Sr .

TABLE 9

Relative yield measurements of $31.6m$ ^{84}Br .

Run foil	Source wt. mg.	Chemical yield %	γ	I° obs.	I° corr.	$S \times 10^6$	$S_{\text{Zr}} \times 10^6$	I° corr(Zr)	Relative yield
20 Al	8.52	37.07	0.300	1220	10,970	0.815	1.071	709	0.630
21 Al	8.41	36.59	0.300	450	4,100	0.828	1.289	285	0.694
22 Al	2.78	12.00	0.305	820	22,404	0.840	1.449	1916	0.625

Relative yield of $^{84}\text{Br} = 0.650 \pm 0.022$.

(3) Strontium

9.7h ^{91}Sr was the only strontium isotope suitable for measurement. The decay chain for this mass is

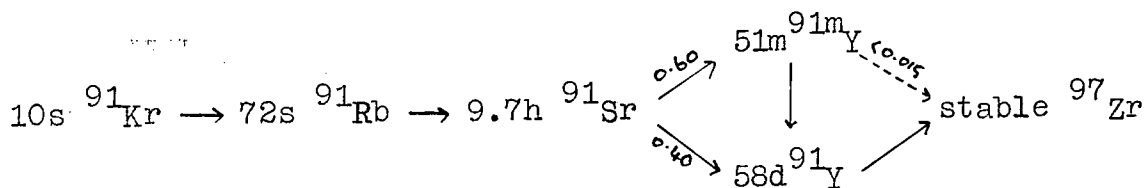

Longer-lived, Sr isotopes (50.5d ^{89}Sr and 28.0y ^{90}Sr) were not detected. Strontium was separated by the procedure recommended by Sunderman.⁸¹ It was usually separated from aluminium catcher foils dissolved in a mixture of hydrochloric and nitric acids and first precipitated as the carbonate after neutralisation of the solution and addition of excess NaOH to re-dissolve aluminium. The strontium thus isolated was purified from other fission products, except barium, by precipitation with fuming nitric acid and scavenging an aqueous solution twice with ferric hydroxide. Barium carrier was then added and two precipitations of barium chromate carried out. The strontium was mounted for yield determination and counting as the oxalate. A description of the chemical procedure and of the preparation and standardisation of the carrier solution is given in the appendix.

Tests with ^{233}Pa solution showed that by following this procedure decontamination was > 99.9%; decay curves

obtained for samples from irradiated target material, however, showed a low level of long-lived activity which could always be readily resolved from the 9.7 hr. component.

Counting was never begun until about 24 hours after the end of the irradiation to allow for the decay of 2.7 hour ^{92}Sr and its daughter 3.6 hour ^{92}Y .

Calibration of the end-window counter.

A solution of high specific activity (about 10^6 dpm/mg. of strontium) was obtained from reactor irradiated uranium using the separation procedure outlined above, reduced for working with 1 mg. of added carrier. This solution was standardised by $4\pi\beta$ proportional counting and a range of solid sources of strontium oxalate prepared for counting under the end-window counter. In the calculation of the absolute activity of the solution from the observed count rate in the 4π sources it was necessary to allow for the presence 51 min. $^{91\text{m}}\text{Y}$ which decays by internal transition with 5% conversion and is produced in 60% of the strontium disintegrations.

In the solid and 4π sources a considerable contribution from longer lived species was observed; this would be expected since a one day irradiation at high flux would lead to the formation of appreciable amounts of long lived strontium isotopes. The curves could, however, be resolved

TABLE 10

Relative yield measurements of 9.7h ^{91}Sr .

Run	foil	Source	Chemical	η	I° obs	I° corr.	$S \times 10^6$	$S_{\text{Zr}} \times 10^6$	I° corr. (Zr)	Relative yield
2	Al	14.62	61.87	0.325	780	3879	1.003	1.029	1752	1.296
6	Al	3.89	16.46	0.270	330	7425	1.145	1.154	3183	1.341
7	Al	9.47	40.07	0.266	2000	18483	3.467	35.22	9447	1.134
8	Al	4.05	17.14	0.270	310	6699	1.209	1.232	3099	1.257
10	Al	9.61	40.67	0.266	950	8782	1.256	1.276	3505	1.452

Relative yield of $^{91}\text{Sr} = 1.30 \pm 0.07$

caustic soda to an acid solution of the catcher foils. A number of yttrium fluoride precipitations were then carried out in the presence of zirconium hold-back carrier and the yttrium re-precipitated as the hydroxide. It was then extracted twice from concentrated nitric acid solution with T.B.P. and scavenged with ceric iodate. After further hydroxide precipitations it was mounted for counting as yttrium oxalate. The procedure used and the method of preparation and standardisation of the carrier solution are given in the appendix.

The stoichiometry of yttrium oxalate has been questioned⁹¹ and the chemical yield was therefore determined by dissolving the oxalate in dilute hydrochloric acid, adding excess EDTA and back titrating with zinc solution at pH 10 using Eriochrome Black T as indicator.⁹²

Counting of the sources was not begun until 24 to 30 hours after preparation to allow time for the decay of 3.6 hour ⁹²Y and its parent 2.7 hour ⁹²Sr. Sources thus treated decayed to a low back-ground of long lived activity and the curves were readily resolved to give a component with the expected 10.3 hour half-life.

Calibration of the End-window Counter.

A solution of ⁹³Y with a specific activity of about 10^6 dpm/mg. yttrium was prepared from a sample of uranium irradiated in a

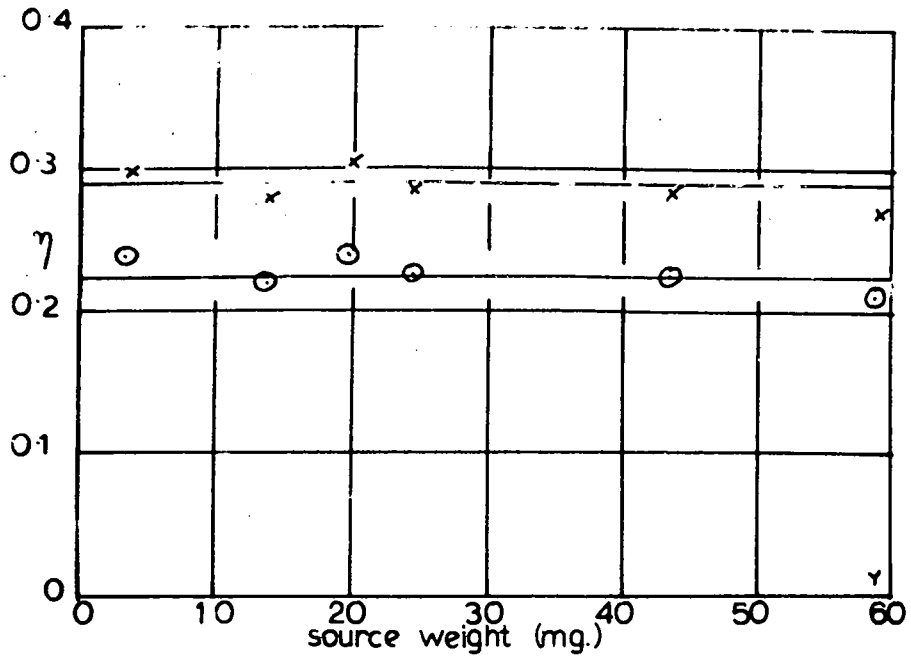

Fig.15 Graph of counter efficiency against source weight for ^{137}Cs

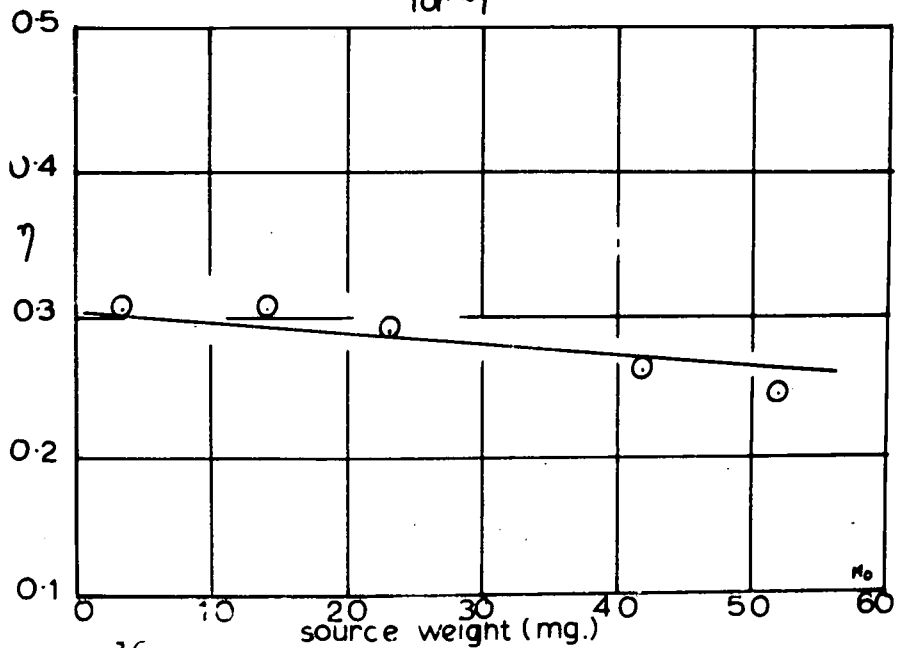

Fig.16 Graph of counter efficiency against source weight for ^{99}Mo .

TABLE 11

Relative yield measurements of 10.3h ^{93}Y .

Run	foil	Source	Chemical	γ	I° obs.	I° corr.	$S \times 10^6$	$S_{\text{Zr}} \times 10^6$	I° corr.(Zr)	Relative yield
1	Al	17.43	50.95	0.295	1150	7652	1.558	1.635	3470	1.402
2	Al	9.79	28.62	0.295	380	4501	1.005	1.029	1752	1.593
9	Al	17.87	50.17	0.295	1350	9121	1.522	1.548	3480	1.615
10	Al	22.00	64.87	0.225	1325	9078	1.257	1.276	3505	1.593

Relative yield of $^{93}\text{Y} = 1.55 \pm 0.06$.

Tests with ^{233}Pa showed the decontamination achieved in this procedure was $> 99.9\%$ and the decay of the fission product sources could be resolved to give a component with the expected 67 hour half-life. Counting was always delayed to allow 6 hour $^{99\text{m}}\text{Tc}$ to reach equilibrium with the parent.

A description of the chemical procedure and of the preparation and standardisation of the carrier solution are given in the appendix.

Calibration of the End-window Counter.

A solution of ^{99}Mo was obtained and 4 π and solid sources prepared as described in Chapter 2. $^{99\text{m}}\text{Tc}$ was allowed to come to equilibrium and the disintegration rate of the ^{99}Mo was found from the decay of the 4 π sources by the method of Freiling and Bunney⁹⁴; the efficiency for various weights of source was then calculated. These values are shown in fig. 16 and the results of the relative yield measurements for ^{99}Mo are given in table 12. One determination was made of the yield of ^{99}Mo relative to ^{97}Zr using the uranium foils (table 13); the value found was 1.12 which compares with the previously measured value of 1.09 ± 0.04 .

(6) Ruthenium

Relative yields of 4.45 hour ^{105}Ru which occurs in the decay chain

TABLE 12

Relative yield measurement of 67h ^{99}Mo .

Run	foil	Source	Chemical	γ	I° obs	I° corr.	$S \times 10^6$	$S_{\text{Zr}} \times 10^6$	I° corr. (Zr)	Relative yield
6	Al	23.06	58.99	0.292	105	608	1.163	1.154	3183	0.747
7	Al	18.18	46.50	0.297	285	2064	3.576	3.522	9417	0.851
8	Al	23.20	59.35	0.330	105	536	1.255	1.232	3099	0.669
9	Al	19.44	49.72	0.335	112	672	1.576	1.549	3480	0.748
10	Al	16.99	43.46	0.335	98	673	1.295	1.276	3622	0.721
16	Cu	30.17	77.18	0.325	77	307	0.871	0.859	1572	0.759

Relative yield of $^{99}\text{Mo} = 0.749 \pm 0.034$.

Two irradiations were carried out using the uranium targets and the yield of ruthenium determined relative to that of zirconium. The results are recorded in table 13; it can be seen that the average value is 0.423 ± 0.029 which is comparable with the previously measured value of 0.443 ± 0.033 . This indicates that the procedure used should also give satisfactory results with protactinium.

Calibration of the End-window Counter

The efficiency of the end window counter for different weights of source was calculated by the method of Bayhurst and Prestwood⁸⁰ as described in Chapter 2, section k. These values are plotted against source weight in fig. 16, and the values of the relative yield of ^{105}Ru are given in table 14.

Silver from Palladium

Some attempts were made to determine the relative yields of ^{109}Pd and ^{112}Pd by resolution of the decay curves obtained from palladium samples but this could not be done unambiguously with the counting rates obtained. The yield of mass 112 can, however, be determined by milking 3.2 hour ^{112}Ag from palladium. The decay chain for this mass is:-

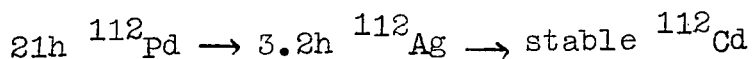

Palladium was separated from aluminium catcher foils using the

TABLE 13

Nuclide	Run	foil	Source	Chemical	γ	I° obs.	I° corr.	$S \times 10^6$	$S_{Zr} \times 10^6$	I° corr. (Zr)	Relative yield
Zr	23	Al	27.03	38.30	0.635	940	3865	-	1.292	-	-
Zr	24	Al	30.26	42.88	0.635	880	3232	-	1.148	-	-
Ru	23	Al	4.14	43.22	0.325	870	6194	1.222	1.292	3865	0.443
Ru	24	Al	5.31	34.48	0.305	490	4659	1.078	1.148	3232	0.402
Mo	24	Al	27.24	67.68	0.330	210	940	1.167	1.148	3232	1.12

Relative yields of ^{105}Ru and ^{49}Mo (Uranium samples).

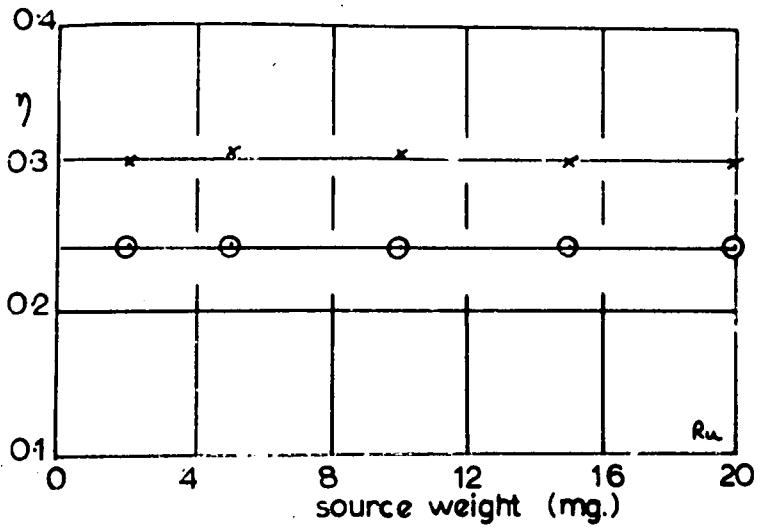

Fig. 16a. Counter efficiency against source
weight for ¹⁰⁵Ru.

TABLE 14

Relative yield measurements of $4.45\text{h }^{105}\text{Ru}$.

Run	foil	source	chemical	γ	I° obs.	I° corr.	$S \times 10^6$	$S_{\text{Zr}} \times 10^6$	I° corr(Zr)	Relative yield
11	Al	4.54	47.40	0.305	410	2836	1.329	1.380	2900	0.266
12	Al	4.97	32.28	0.245	265	3351	1.054	1.115	2854	0.325
26	Al	3.10	20.13	0.305	740	12052	6.5241	6.7210	10047	0.323

Relative yield of $^{105}\text{Ru} = 0.305 \pm 0.019$.

method of Glendenin.⁹⁶ It was first precipitated with dimethylgloxime from a solution 1-2M in acid and the complex was then destroyed by heating with concentrated nitric acid. Iron (III) hydroxide and silver iodide scavenges followed and palladium was finally re-precipitated with dimethylgloxime for the determination of the chemical yield. This precipitation was carried out at a known time, the precipitate again dissolved in nitric acid, silver carrier added and the solution left for some hours to accumulate ¹¹²Ag. Silver was then precipitated, as the chloride, at a known time and scavenged several times with iron; it was then re-precipitated and counted. Occasionally some long lived activity was found in these sources but the decay curves could be resolved to give a component with the expected half-life of 3.2 hours. Palladium was re-precipitated after removal of the silver, weighed, dissolved and again left for the growth of silver. The milking was continued until the activity in the silver sources became too low for measurement.

Descriptions of the chemical procedures used and of the preparation and standardisation of the carriers are given in the appendix.

In the calculation of the relative yield of ¹¹²pd the activity at the end of the irradiation was found by calculating

the activity at the times of removal of silver and plotting a decay curve for palladium. The silver was rarely left to attain equilibrium with the palladium but the appropriate correction has been applied.

If $^{112}\text{Pd} = 1$, $^{112}\text{Ag} = 2$, $t =$ time for growth of silver, $I_2 =$ activity of silver at the time of milking and $I_1^0 =$ activity of palladium before silver appeared (that is, at the time of the previous separation), then,

$$I_1^0 = I_2 \frac{\lambda_2 - \lambda_1}{\lambda_2} \frac{1}{(e^{-\lambda_1 t} - e^{-\lambda_2 t})}$$

The values of I^0 were corrected for the chemical yields of silver and palladium, and for the efficiency of the counter for ^{112}Ag and a decay curve for ^{112}Pd was constructed.

Calibration of the End-window Counter

The efficiency of the end-window counter for ^{112}Ag was calculated by the method of Bayhurst and Prestwood⁸⁰ as described in Chapter 2, section k; a graph of efficiency against source weight is shown in fig. 17 and the results of the relative yield measurements of ^{112}Pd are given in table 15.

(7) Silver

5.3 hour ^{113}Ag was separated. The decay chain for this mass has been given in Chapter 3, page 59. About 15 minutes

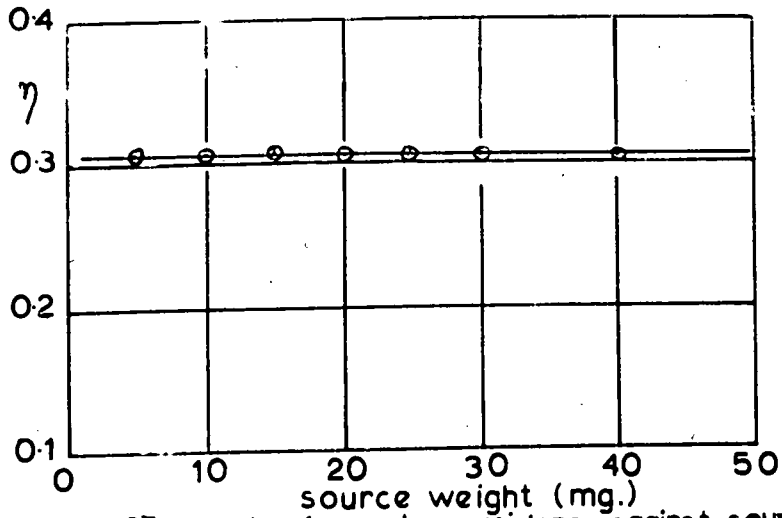

Fig.17 Graph of counter efficiency against source weight for ^{110}Ag

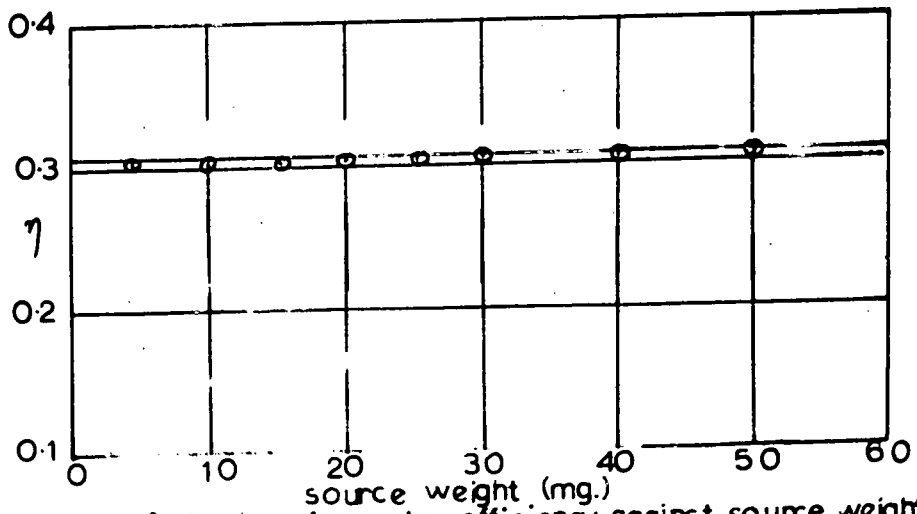

Fig.18 Graph of counter efficiency against source weight for ^{110}Ag

TABLE 15

Relative yield measurements of 21h ^{112}Pd .

Run	foil	Chemical yield Pd	t min	Chemical yield Ag	(Ag)	I_t (Ag) obs.	I_t (Ag) corr.	I_t (Pd)	I° (Pd)	$S_{\text{Pd}} \times 10^6$	$S_{\text{Zr}} \times 10^6$	I° (Zr) corr	Relative yield
7	Pd	63.71	600	25.38	0.305	107	1383	3046					
		50.55	660	75.39	0.305	211	918	2552	3200	3.535	3.522	9417	0.418
		34.00	420	62.03	0.305	66	349	1516					
25	Al	74.50	540	81.15	0.305	440	1778	3310					
		46.51	725	96.29	0.305	250	859	2592	3500	5.668	5.659	7880	0.541
		28.08	434	90.91	0.305	81	292	1521					
27	Al	67.17	555	92.60	0.305	272	963	2017					
		50.25	778	93.67	0.305	145	508	1449	2120	3.671	3.659	5445	0.479
		45.34	420	97.95	0.325	90	283	922					

Relative yield of $^{112}\text{Pd} = 0.479 \pm 0.035$.

was allowed for the decay of 1.4 minute ^{113}Pd and 1.2 minute $^{113\text{m}}\text{Ag}$ before the separation was begun. Tests with ^{233}Pa showed that the decontamination achieved in the method used (which has been outlined in Chapter 3) was $> 99.9\%$ and the fission product sources were always readily resolved to give the component with the expected half-life of 5.3 hours.

The chemical separation procedure and the preparation and standardisation of the carrier are given in the appendix.

The first few determination of the relative yield of this nuclide were carried out using polystyrene catcher foils; these were then dissolved in benzene in the presence of strong acid and carrier solutions and the mixture shaken for a few minutes. Concordant results were obtained for the relative yields but when the measurements were repeated using aluminium foils the value of the relative yield was found to be half the previous value. This suggested that the procedure used with the polystyrene foils was not providing complete exchange between the carriers and active species. When the experiments on polystyrene were repeated and the carriers and benzene solution of the foils shaken for 10 minutes in the presence of strong nitric acid and for 10 minutes after the addition of hydrofluoric acid to make the concentrations about 4N in this acid values in agreement with those found using aluminium

catchers were then obtained. These results are given in table 16.

Calibration of the End-window Counter

The efficiency of the end window counter for sources of ^{113}Ag was calculated by the method of Bayhurst and Prestwood⁸⁰ as described in chapter 2, section (k); the values obtained are plotted against source weight in fig. 18.

(8) Antimony

^{129}Sb , which was a half-life of 4.6 hours, was separated; it is an isobar in the chain

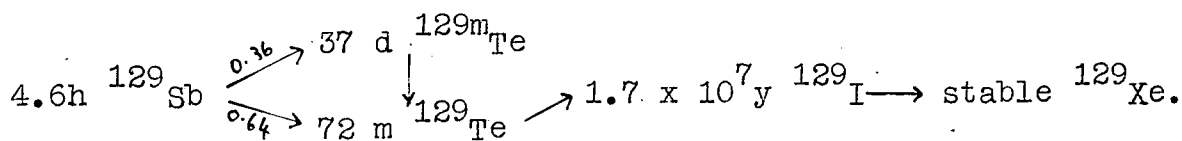

The element was separated from both copper and aluminium catcher foils, and since it forms a volatile hydride and considerable evolution of hydrogen takes place during the dissolution of aluminium this was always carried out by the use of caustic soda. After boiling for some time the solution was acidified with a mixture of sulphuric and perchloric acids (in the presence of hydrochloric acid some antimony might be lost as volatile chloride). When copper foils were used these were dissolved in nitric acid. Either solution was then boiled with a few drops of bromine to

TABLE 16

Relative yield measurements for 5.3h ^{113}Ag .

Run	foil	source	Chemical wt.mg. yield %	γ	I° obs.	I° corr.	$S \times 10^6$	$S_{\text{Zr}} \times 10^6$	I° Corr.(Zr)	Relative yield
2	Al	12.79	47.16	0.305	440	3059	0.958	1.029	1752	0.584
3	Al	8.76	32.30	"	470	4771	1.428	1.506	2701	0.581
4	PS	10.64	36.82	"	340	3028	1.614	1.670	1633	0.598
5	PS	12.18	42.14	"	460	3579	1.300	1.332	1929	0.592
8	Al	8.24	28.51	"	415	4773	1.166	1.232	3019	0.521

Relative yield of $^{113}\text{Ag} = 0.575 \pm 0.017$.

ensure oxidation of antimony to Sb(V) . When using aluminium the solution was made 1-2M in acid and antimony precipitated as the sulphide; from copper foils it was first precipitated by the addition of ammonia, separated, re-dissolved in dilute acid and precipitated as the sulphide. The subsequent procedure was the same for both copper and aluminium foils. The sulphide precipitate was dissolved in 0.5M potassium hydroxide, scavenged with iron and re-precipitated on addition of acid. It was next dissolved in concentrated hydrochloric acid and purified by the method⁹⁷ which is given in the appendix together with the method of preparation and standardisation of the carrier solution. Antimony was finally precipitated as the element for counting.

Tests with ²³³Pa showed that the initial iron scavenge was necessary; decontamination was then > 99.9% . The decay curves observed for the fission product sources showed some long-lived background activity which could, however, be resolved from the 4.6 hour component. Counting was not begun until about 5 hours after the preparation of the source to allow 72 minute ¹²⁹Te to come to equilibrium with the parent.

Calibration of the End-window Counter

The counter was calibrated using a solution of antimony

(10^5 dpm/mg) obtained from a sample of reactor irradiated uranium by the procedure used in preparation of the fission product sources reduced for working with 1 mg of carrier. The efficiency was then calculated as described in Chapter 2, section (k). Decay curves obtained for both the 4π and solid sources showed the presence of long-lived activities but resolution for 4.6h ^{129}Sb was always possible. The observed counting rates of the 4π sources were corrected for the presence of 72m ^{129}Te which is formed in 64% of the antimony disintegrations. Some calculations of the efficiency were also made using the method of Bayhurst and Prestwood⁸⁰ and a curve of efficiency against source weight (showing points obtained by both methods) is given in fig. 19. The results of the relative yield measurements of ^{129}Sb are given in Table 17.

(9) Tellurium

Measurements were made of the relative yield of ^{132}Te which is a member of the decay chain:

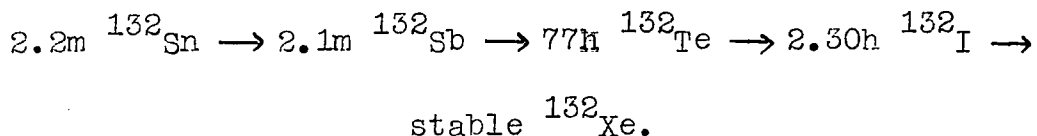

The irradiated material was left for about 20 minutes to ensure decay of 2.2m Sn and 2.1m Sb. Tellurium was separated⁹⁸ from aluminium catcher foils which were dissolved in acid, boiled for a short time with a little 1M potassium

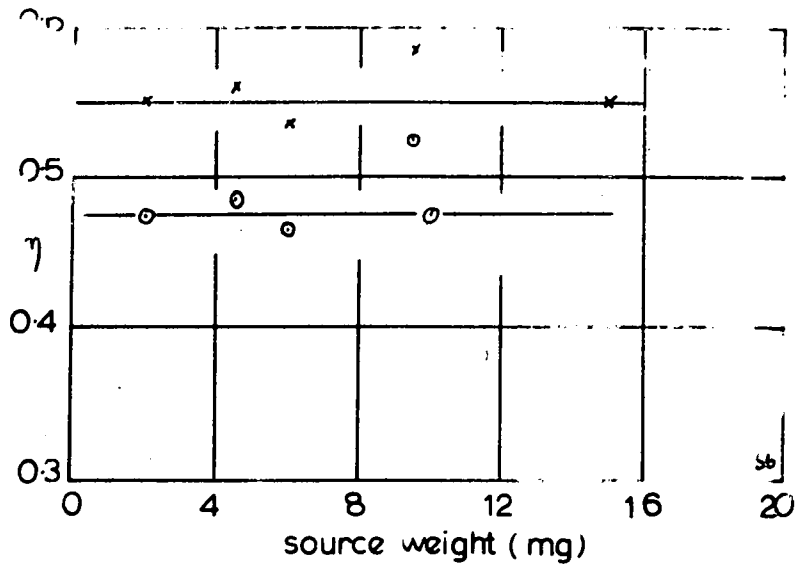

Fig.19. Counter efficiency against source weight for ^{129}Sb .

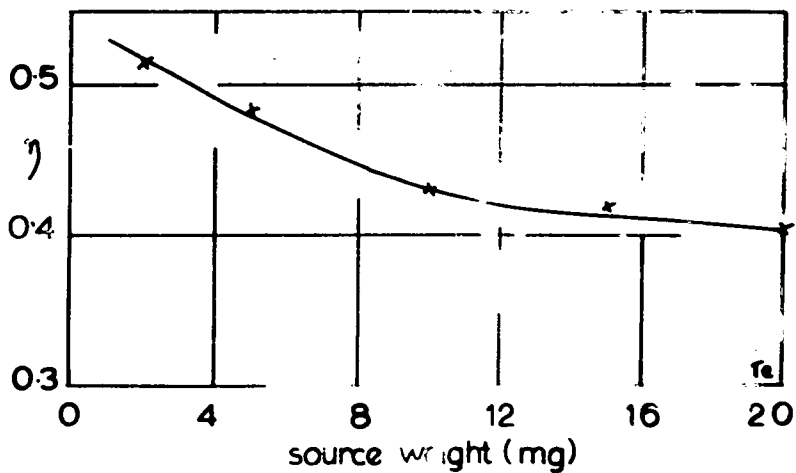

Fig.20. Counter efficiency against source weight for ^{132}Te .

TABLE 17

Relative yield measurements of ^{129}Sb .

Run	foil	Source wt. mg.	Chemical yield %	γ	I° obs.	I° corr.	$S \times 10^6$	$S_{\text{Zr}} \times 10^6$	I° corr. Zr	Relative yield
15	Cu	3.12	29.06	0.490	172	1208	0.863	0.909	2388	0.139
18	Al	4.63	43.13	0.555	270	1129	1.281	1.361	2602	0.121
19	Al	6.39	59.52	0.555	800	2422	1.940	1.997	4392	0.149

Relative yield of $^{129}\text{Sb} = 0.136 \pm 0.007$.

permanganate to promote exchange, the excess permanganate was destroyed with hydrogen peroxide and the tellurium carried down on ferric hydroxide. It was then purified by a series of precipitations in the elemental form interspersed with scavenges by ferric hydroxide precipitations and mounted for counting and yield determination as the element.

Tests with ^{233}Pa showed that decontamination was satisfactory, but when sources were prepared from irradiated catcher foils they were found to be contaminated with an activity of approximately 20 hours half-life. This was attributed to 19 hour ^{194}Ir (produced by $^{124}\text{Pt} (n,p) ^{194}\text{Ir}$ or $^{197}\text{Au} (n,\alpha) ^{194}\text{Ir}$) and 18 hour ^{197}Pt (produced by $^{197}\text{Au}(n,p) ^{197}\text{Pt}$); the gamma spectrum indicated most contribution from ^{194}Ir . When the procedure was carried out in the presence of rhodium carrier this contamination was reduced to a tolerable level.

A description of the procedure used, and of the preparation and standardisation of the carrier solution used are given in the appendix.

Counting was not begun until about 24 hours after the preparation of the source to allow time for ^{132}I to grow into equilibrium.

Calibration of the End-window Counter

The efficiency of the end-window counter for different source weights was calculated by the method of Bayhurst and Prestwood⁸⁰ as described in chapter 2, section k using the expression for species in transient equilibrium. These values are shown plotted against source weight in fig. 20 and the values of the relative yield of ^{132}Te are given in table 18.

(10) Cerium

33 hour ^{143}Ce was separated. The decay chain for this mass is:-

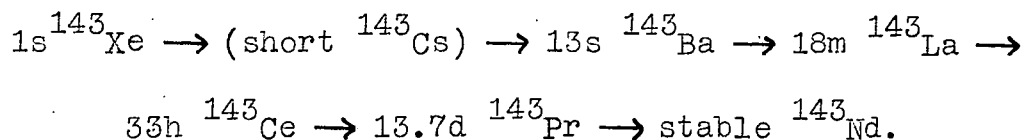

The cerium was separated from copper and aluminium foils and was first precipitated as the hydroxide after boiling the solution with a little saturated sodium bromate followed by hydroxylamine to promote exchange. The procedure used for further purification of cerium was that of Hunter and Perkins.⁹⁹ The hydroxide was dissolved in hydrochloric acid and a number of precipitations of cerous fluoride carried out; two precipitations of ceric iodate and a zirconium iodate scavenge followed. Cerium was then precipitated as ceric hydroxide, reduced to the cerous

TABLE 18

Relative yield measurements of 77h ^{132}Te .

Run	foil	source	Chemical	η	I° obs.	I° corr.	$S \times 10^6$	$S_{\text{Zr}} \times 10^6$	I° corr (Zr)	Relative yield
25	Al	2.93	29.65	0.505	295	1970	5.697	5.659	7880	1.13
28	Al	1.17	11.84	0.535	75	1184	3.853	3.786	5161	1.04
29	Al	6.65	67.29	0.467	980	3150	12.090	11.955	11286	1.25

Relative yield of $^{132}\text{Te} = 1.14 \pm 0.06$.

state and precipitated as cerous hydroxide which was dissolved in dilute acid and the cerium then precipitated for yield determination and counting as the oxalate. The separation was not begun until about three hours after the irradiation to allow for the decay of $18m. \text{}^{143}\text{La}$.

Tests with ^{233}Pa solution showed that three cerous fluoride precipitations were necessary to give 99.9% decontamination from protactinium; sources prepared from fission products decayed to a long-lived background activity, but this could always be resolved from the 33 hour component.

The chemical procedure used and the preparation and standardisation of the carrier solution are given in the appendix.

Calibration of the End-window Counter

A sample of reactor irradiated cerous oxide was dissolved to give a solution in which the specific activity of ^{143}Ce was about 10^5 dpm/mg. Solid and 4π sources were prepared and the efficiency calculated as before. The decay curves showed a considerable contribution from 33 day ^{141}Ce which could, however, be easily resolved to give the initial activity of ^{143}Ce .

A graph of efficiency against source weight is shown in fig. 21 and the results of the relative yield measurements are given in table 19.

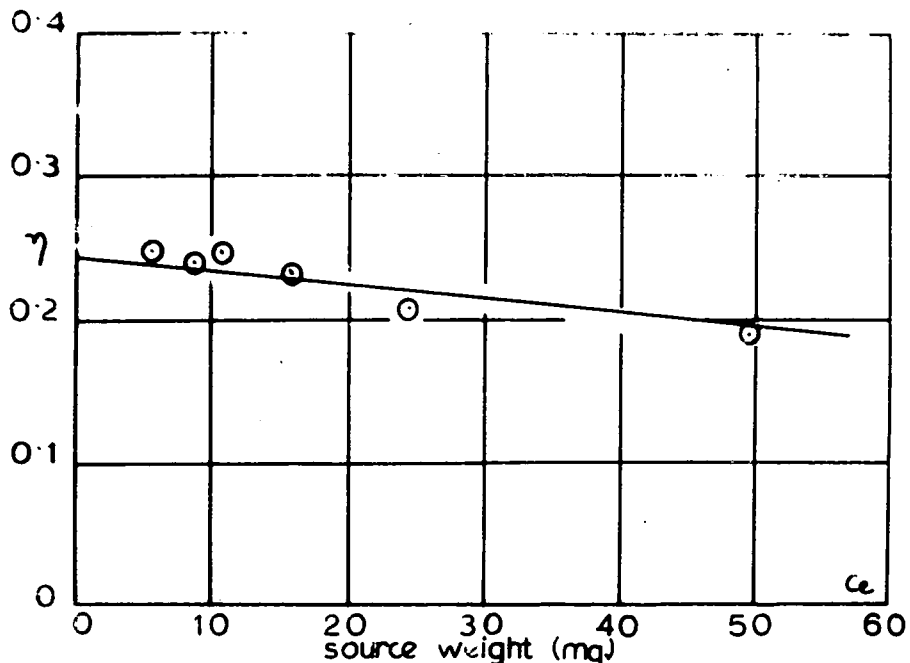

Fig.21: Graph of counter efficiency against source weight for ^{137}Ce .

TABLE 19

Relative yield measurements of ^{143}Ce

Run	foil	Source wt. mg.	Chemical yield %	γ	I° obs.	I° corr.	$S \times 10^6$	$S_{\text{Zr}} \times 10^6$	$I^{\circ}_{\text{corr.}}$ (Zr)	Relative yield
13	Al	20.33	81.16	0.225	105	575	0.861	0.850	1441	0.765
14	Al	12.12	48.39	0.225	45	406	0.742	0.731	1064	0.815
15	Cu	21.82	87.11	0.220	168	877	0.918	0.909	2022	0.834
17	Cu	11.47	45.79	0.234	118	1096	0.904	0.892	2087	0.713

Relative yield of $^{143}\text{Ce} = 0.782 \pm 0.031$.

CHAPTER 5Collected Results for Protactinium(a) Correction of Measured yields to Total Chain Yields

In order to obtain total chain yields from the measured yields of nuclides removed from the stable end-product of a β decay chain it is necessary to apply a correction for the charge distribution at the instant of fission. The postulates of 'equal charge displacement'²⁵ and 'unchanged charge distribution'²⁴ which have been advanced to explain the observed charge distributions are briefly described in Chapter 1.

It appears that the equal charge displacement hypothesis is in reasonable agreement with the observed charge distributions in low energy fission. For example, Steinberg and Glendenin¹⁰⁰ have compared the observed values for ^{235}U , ^{233}U , ^{239}Pu and ^{242}Cm and find that the charge distribution curve of Glendenin, Coryell and Edwards²⁵ gives the best agreement.

Some measurements made by Kennett and Thode¹⁰¹ are not in agreement with this hypothesis and they postulated a charge division such that the greatest energy release occurs in fission. The extension of this treatment to all mass regions has been questioned.⁵⁶

It also seems that the equal charge displacement hypothesis may be applied to the charge distributions found for

fission induced at moderate excitation energies. Wahl¹⁰² has measured independent yields for ^{235}U in which fission was induced by 14 Mev neutrons, and Alexander and Coryell⁵⁶ have considered the case of ^{232}Th caused to fission by bombardment with 13.6 Mev deuterons and by neutrons with an energy spread of up to 19 Mev.

When fission is induced by particles of 20-30 Mev, however, it seems that the observed charge distribution is intermediate between the equal charge displacement and unchanged charge distribution hypotheses; this was found, for example, in an investigation¹⁰³ of the yields from ^{239}Pu bombarded with 20 Mev deuterons, ^{237}Np with 31 Mev deuterons, ^{233}U with 23 Mev deuterons and ^{237}Np with 46 Mev helium ions.

When thorium is bombarded with deuterons the compound nucleus formed will be ^{234}Pa and since Alexander and Coryell⁵⁶ have found that the equal charge displacement hypothesis gives reasonable agreement with their measurements of independent yields it seems that this hypothesis may also be used to calculate independent yields from the neutron induced fission of ^{231}Pa .

The equal charge displacement hypothesis may be written as

$$Z_A - Z_P = Z_A^* - Z_P^*$$

where Z_A and Z_A^* are the most stable charges of complementary fission product chains and Z_P and Z_P^* are the most probable charges for the primary fission fragments A and A*. The sum of the primary charges Z_P and Z_P^* must equal the charge of the fissioning nucleus Z_f ,

$$Z_P + Z_P^* = Z_f$$

and the complementary fission product masses are related by

$$A + A^* = A_f - \bar{\nu}$$

where A_f is the mass of the fissioning nucleus and $\bar{\nu}$ is the average number of neutrons emitted per fission.

The most probable charge of a fission product of mass number A is then

$$Z_P = Z_A - \frac{1}{2}(Z_A + Z_A^* - Z_f)$$

Z_P can be calculated if Z_A and $\bar{\nu}$ are known. In the present calculations the value of $\bar{\nu}$ was taken to be 4.25; this is a value chosen from a consideration of measurements made for neighbouring nuclides induced to fission by 14 Mev neutrons since direct measurements have not been made. These values are given in table 20.

Glendenin, Coryell and Edwards²⁵ calculated their values for Z_A using the Bohr-Wheeler mass equation¹⁹ which, however, does not account for shell effects. Bappas,¹⁰⁴ therefore modified the method of estimating Z_A and based his

TABLE 20

Number of prompt neutrons emitted in the fission of various nuclides.

Nuclide	$\bar{\nu}$	ref.
^{232}Th	4.6	116
^{233}U	4.4	117
^{235}U	4.5	117
^{238}U	4.5	118
^{239}Pu	4.7	117

calculations on the treatment of β stability made by Coryell.¹⁰⁵ The Z curves show discontinuities at shell edges. For mass numbers near shell edges two possible values for Z_A therefore exist and Steinberg and Glendenin¹⁰⁰ suggested that the average value should be used.

It has been suggested¹⁰¹ that a correction should be made for shell effects on Z_P . Various features of the resulting functions, however, have not been found to agree with the empirical Z_P function determined by Wahl.¹⁰⁶

The values of Pappas¹⁰⁴ have been used in the present calculations and, after the determination of $Z-Z_P$, the independent yields of the last members of the chains were found from a charge distribution curve¹⁰⁷ which is similar to that of Glendenin, Coryell and Edwards²⁵ but has been modified to include more recent data. The calculations are given in table 21.

The correction of the measured values of the relative yields to total chain yields is given in table 22.

(b) Discussion

The measurement of the relative yields of a number of nuclides from the 14 MeV neutron induced fission of ^{231}Pa has been described in previous chapters; in the first

TABLE 21

A	Nuclides measured	Z _A	A [*]	Z _A [*]	Z _A [*] + Z _A	Z _P	Z	Z-Z _P	I.Y. successors	% measured
84	31.6m 84 Br	36.6	143.75	60.2	96.8	33.7	35	1.30	2.8x10 ⁻³	99.72
91	9.7h 91 Sr	40.2	136.75	57.0*	97.2	37.1	38	0.9	1.5x10 ⁻² 1.3x10 ⁻⁴	98.49
93	10.3h 93 Y	41.0	134.75	55.6	96.6	38.2	39	0.8	2.3x10 ⁻² 2.3x10 ⁻⁴	97.68
97	17h 97 Zr	42.6	130.75	54.2	96.8	39.7	40	0.3	1x10 ⁻¹ 3x10 ⁻³	89.70
99	67h 99 Mo	43.4	128.75	53.75	96.9	40.45	42	1.55	9x10 ⁻⁴	99.91
105	4.45h 105 Ru	45.7	122.75	51.4	97.1	42.65	44	1.35	2x10 ⁻³	99.80
112	21h 112 Pd	48.5	115.75	50.0	98.5	44.75	46	1.25	3.2x10 ⁻³	99.68
113	5.3h 113 Ag	48.9	114.75	49.6	98.5	45.15	47	1.85	1.5x10 ⁻⁴	99.99
129	4.6h 129 Sb	33.6	98.75	43.3	96.9	50.65	51	0.35	9x10 ⁻² 2x10 ⁻³	90.80
132	77h 132 Te	54.5	95.75	42.07	96.57	51.70	52	0.30	1x10 ⁻¹ 3x10 ⁻³	89.70
143	33h 143 Ce	59.9	84.75	36.9	96.8	57.0	58	1.00	1x10 ⁻²	99.00

Calculated values of Z-Z_P and independent yields of the successors.

* Average of two values.

TABLE 22Correction of measured yields to total chain yields

Mass no.	Measured [*] yield	% chain	Total chain yield	No. of observations
84	0.650 ± 0.022	99.72	0.652 ± 0.022	3
91	1.30 ± 0.07	98.49	1.33 ± 0.07	5
93	1.55 ± 0.06	97.68	1.59 ± 0.06	4
97	1.00	89.70	1.12	
99	0.749 ± 0.034	99.91	0.749 ± 0.034	6
105	0.305 ± 0.019	99.80	0.306 ± 0.019	3
112	0.479 ± 0.035	99.68	0.481 ± 0.035	3
113	0.575 ± 0.017	99.99	0.575 ± 0.017	5
129	0.136 ± 0.007	90.80	0.150 ± 0.007	3
132	1.14 ± 0.06	89.70	1.27 ± 0.06	3
143	0.782 ± 0.031	99.00	0.790 ± 0.031	4

* The errors quoted are expressed as standard errors of the means.

half of this chapter the correction of these yields to total chain yields was discussed. Corrected, relative yields are converted to absolute yields assuming that the sum of all yields is 200%. A list of these normalised values is given in table 23 and plotted against mass number in fig. 22. If each fission gives rise to two fragments and a number of neutrons only, and if the number of neutrons emitted is known, the masses of fragments complementary to those measured may be found and plotted on the mass-yield curve as 'mirror points'. The number of neutrons emitted has been assumed to be 4.25 as discussed in the first half of this chapter.

Fig. 22 shows that the mass-yield curve for protactinium has two maxima in the yields of light and heavy fragments, as is usual in this mass region, but that a third maximum appears in the region of near symmetric fission.

The distribution may be compared with those observed for other fissioning systems. The mass-yield curve is plotted again in figs. 23 and 24 where it is compared with those for the fission of thorium induced by deuterons of two energies^{56,60} and with those for the 14 MeV neutron induced fission of ^{232}Th ⁵⁹ and ^{238}U .^{66,67} In table 24 these, and several other, distributions are again compared.

TABLE 23

Absolute Mass-yields for the fission of ^{231}Pa with
14 MeV neutrons.

Mass No.	Absolute yield %
84	2.78 \pm 0.16
91	4.97 \pm 0.40
93	6.80 \pm 0.36
97	4.92
99	3.21 \pm 0.28
105	1.33 \pm 0.12
112	2.05 \pm 0.26
113	2.48 \pm 0.13
129	0.64 \pm 0.09
132	4.97 \pm 0.26
143	3.38 \pm 0.20

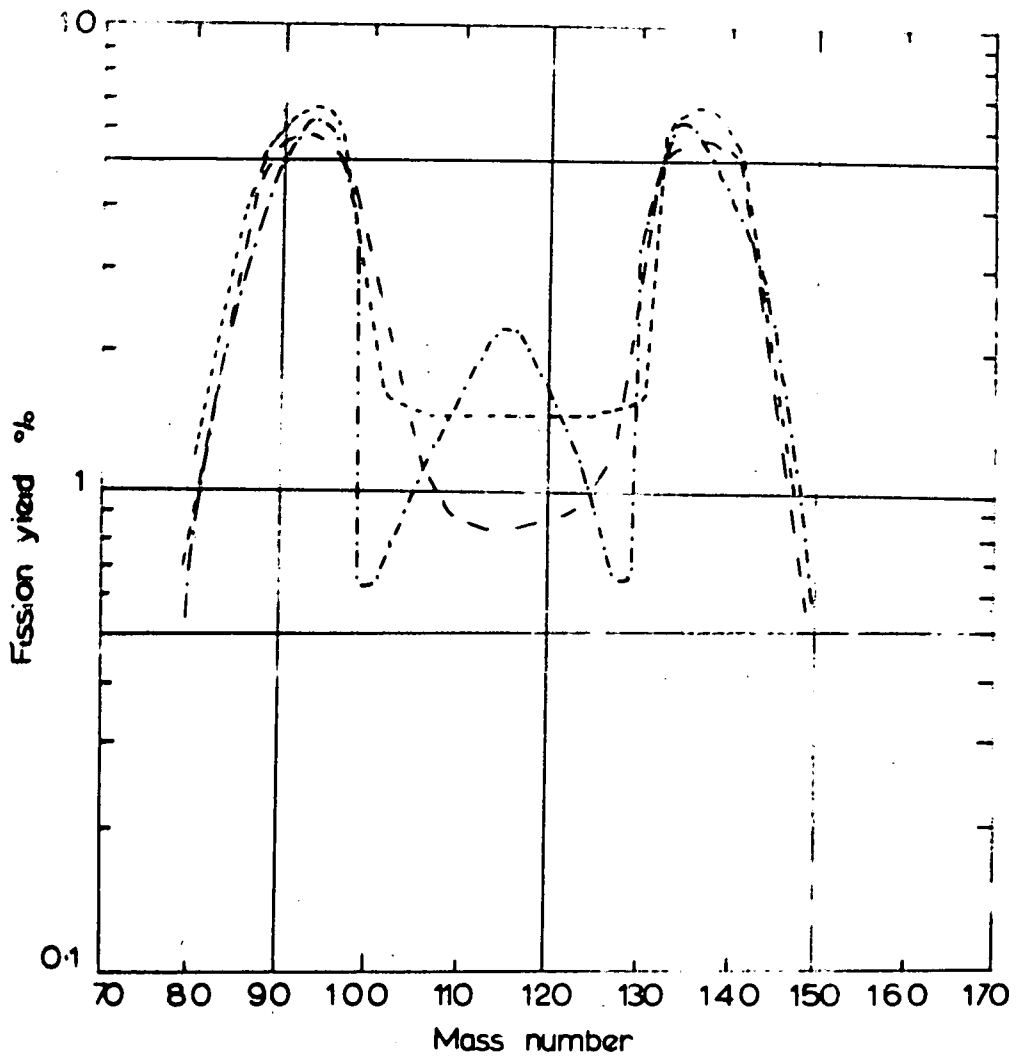

Fig.23. Mass distributions for the fission of thorium induced by deuterons and of protactinium induced by 14 MeV neutrons.

- $^{232}\text{Th} + 95 \text{ MeV deuterons}$
- $^{232}\text{Th} + 136 \text{ MeV}$ "
- . - . ^{231}Pa

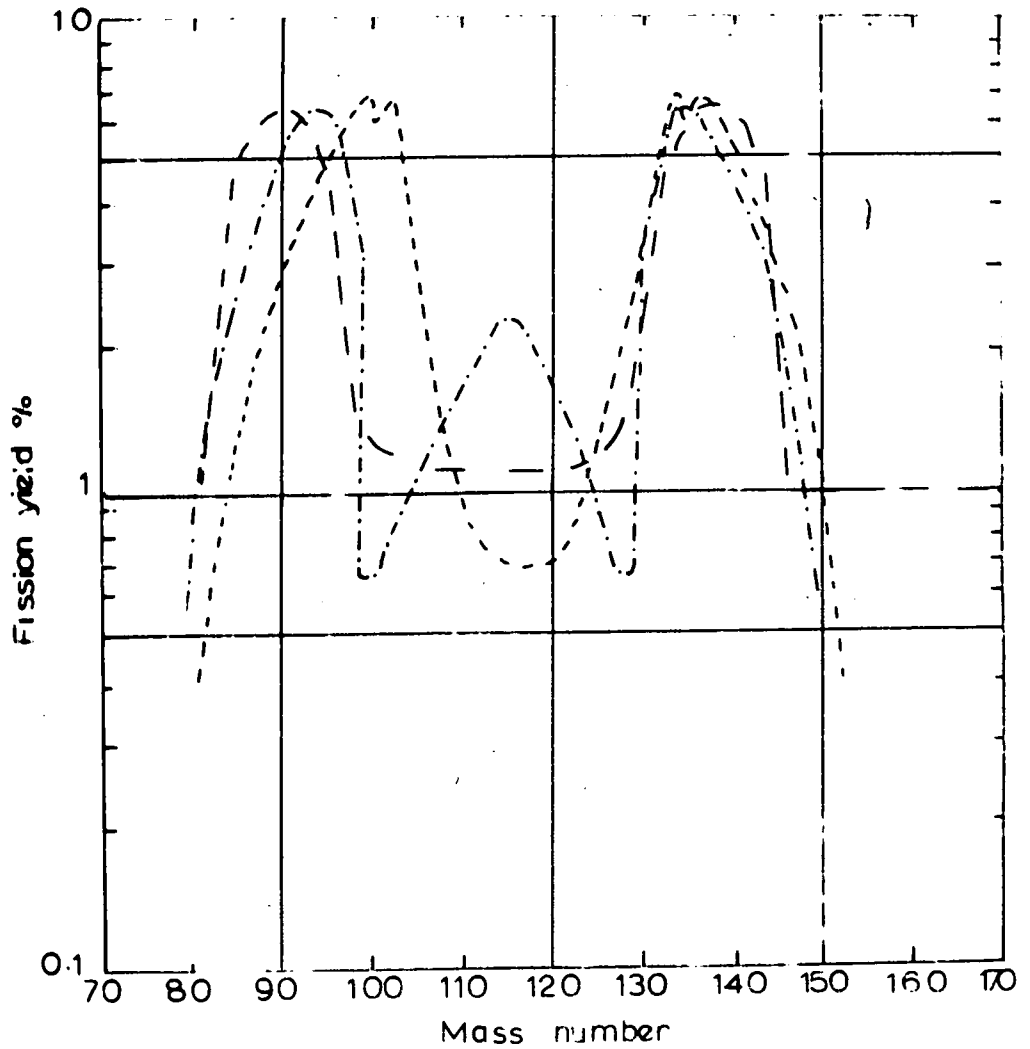

Fig.24. Mass distributions for fission induced by 14 MeV neutrons.

^{232}Tn (dashed line)
 ^{238}U (dash-dot line)
 ^{239}Pu (solid line)

TABLE 24

Fissioning system	Peak Height		Asymm: symm.	Peak width at half-height	Ref.
	Light	Heavy			
$^{226}\text{Ra} + 11\text{Mev p's}$	87	135	1	15, 17, 15	30
$^{231}\text{Pa} + 14 \text{ MeV n's}$	93	135	2.6	14, 17.5, 14	
$^{232}\text{Th} + 14 \text{ MeV n's}$	91	137.4	5.2	12.5	59
$^{232}\text{Th} + 9.5 \text{ Mev d's}$	92	138	6.7	15	60
$^{232}\text{Th} + 13.6 \text{ MeV d's}$	92	137	4.6	12	56
$^{235}\text{U} + 14 \text{ MeV n's}$	95	135	5.2	16	16
$^{238}\text{U} + 14 \text{ MeV n's}$	99	136	9.4	14	66,67
$^{237}\text{Np} + 14 \text{ Mev n's}$	95	137	4.4	16	108

yield parameters for the fission of various nuclides.

For all systems it is found that the position of the maximum in heavy fragment yields is constant within 3 mass units while that in light fragment yields shifts from mass 87 for ^{226}Ra with protons to 95 for ^{237}Np with neutrons. That is, as the mass of the fissioning nucleus increases the maximum yield of the light fragment from asymmetric fission shifts to heavier masses.

According to the compound nucleus model the fissioning species in the neutron induced fission of protactinium will be ^{232}Pa , for ^{232}Th with neutrons ^{233}Th , and for thorium with deuterons ^{234}Pa . It might therefore be expected that the light fragment yields from 14 MeV neutron induced fission of protactinium would reach a maximum at lighter masses than is observed for any of the thorium systems illustrated. It is found, however, that the maximum is in a similar position to that for the deuteron induced fission of thorium and has moved about 2 mass-units to heavier masses compared with the neutron induced fission of thorium. The position of the maximum in heavy fragment yields is in approximately the same position as that for other systems.

A third maximum in yields from symmetric fission has previously been observed for radium bombarded with deuterons 34 and protons, 30 ^{233}U with helium ions 38

rhenium with helium ions³⁷ and for ^{232}Th with reactor neutrons³⁹ where the maximum, if any, is small. Some indications of a small peak have also been found in symmetric fission yields in the neutron induced fission of ^{235}U and the helium ion induced fission of ^{232}Th .¹⁰⁹ Where a definite peak has been observed it is found that it resembles the narrow single peak of the mass-yield distributions from lighter elements such as bismuth³² rather than the broad distribution found for the heavy elements at high excitation energies. A comparison with radium fission indicates that this is also the case for ^{231}Pa . A further similarity between these distributions is that the peak in symmetric fission yields is about 2 mass-units broader than those in asymmetric fission yields.

The peak width of 15 mass-units found for asymmetric fission of ^{231}Pa is similar to that observed for other nuclides (14-17 mass units) except for thorium. A number of investigations of thorium fission have indicated that the peaks are unusually narrow^{56,59} (although this has been questioned).⁶⁰ The extra width of the peaks means that the yields of more asymmetric fission are similar for the neutron induced fission of both ^{231}Pa and ^{232}Th .

The presence and position of the third peak are

indicated by measurements of the relative yields of ^{105}Ru , ^{112}Pd and ^{113}Ag . (The yield of ^{129}Sb indicates the position of the troughs between the peaks.) These all lie on the lighter mass side of the peak, and, unfortunately nuclides in the other side (mass 114-128) fall in a region of isomerism and braching decay. The chains are not always known with certainty and none of the nuclides appeared suitable for measurement. The exact width of the peak therefore depends on the value chosen for the average number of neutrons emitted. A value greater or less than 4.25 by about 0.5 mass units, however, gives a noticeably poorer fit on a smooth curve.

Fine structure has been observed for a number of systems 27,40,41,46 but no indication was found of such an effect in the present measurements.

It appears that the probability of symmetric fission is a rapidly increasing function of the excitation energy of the nucleus.³¹ (for example in fig. 23 the symmetric fission yields are higher for fission induced by 13.6 MeV deuterons than by 9.5 MeV deuterons). It may, therefore, be that in systems where a distinct third peak appears the excitation energy has been particularly enhanced for some reason. Excitation energy will be high at an energy just below that at which neutron emission becomes probable.

(The onset of n emission has been found to correlate with rises and falls in symmetric fission probability for a number of nuclides³¹). It is then possible, that where a high symmetric fission probability is observed, fission is taking place at such an excitation energy. The onset of the emission of one, two or more neutrons is normally known from a study of the variation of fission cross-section with energy; for a number of nuclides this increases in definite steps where the emission of each successive neutron becomes energetically possible. Unfortunately, published measurements of the fission cross-section of ^{231}Pa do not extend above ^3MeV (1.1 barns at this energy)¹¹⁰, the most recent covering only the energy range of 1.5-1500 kev.¹¹¹ Some rough calculations were made by a comparison of activities of one or two nuclides isolated from similar irradiations of the uranium and protactinium samples and it appears that the two cross-sections are somewhat similar (1.3 barns for ^{238}U ¹¹⁰). If this is so, it would appear that additional neutron emission over the energy range of 3 to 15 MeV is a rather improbable process for protactinium. The excitation energy therefore remains high, enhancing the probability of symmetric fission.

This can also provide a qualitative explanation for the position of the maximum in light fragment yields. If neutron emission is improbable at this energy for

^{231}Pa , but not for other elements (which show steps in the cross-section curve) then it is possible that fission in ^{231}Pa is taking place before neutron emission while for these other nuclides fission is following neutron emission. If so the fissioning nucleus may have a higher mass for ^{231}Pa than for ^{232}Th and therefore the maximum in yields of light fragments would be found at heavier masses for ^{231}Pa .

It is impossible to draw firm conclusions in the absence of information on the relative probabilities of fission and neutron emission in this system but it is on these lines that explanations of symmetric fission probabilities have been advanced for other systems. One such discussion has covered the mass region 226-240.⁵⁹ If determinations were made of the fission and total cross-sections at energies above 3 MeV more precise interpretation of the various features of the mass distribution might become possible.

APPENDIXChemical Procedures .

All carrier solutions used contained 5 mg. ml.^{-1} of the element of interest.

(1) ZirconiumCarrier solution

Zirconyl nitrate was dissolved in 1 M nitric acid and the solution standardised by titration with EDTA using xylenol orange as indicator.¹¹³

Separation Procedure

(a) From uranium

(1) A solution of catcher foils was made alkaline and zirconium hydroxide precipitated. The precipitate was dissolved in 5M hydrochloric acid and 10 ml. of a 15% solution of mandelic acid added. After ensuring complete precipitation by heating on the water bath for 10-20 minutes the precipitate was slurried in 2 ml. of water and transferred to a polythene test tube where it was dissolved by the addition of 1 ml. of 20 M HF.

(2) 0.5 ml. of lanthanum carrier were added, the precipitate of lanthanum fluoride centrifuged down and the process repeated finally discarding the precipitates.

(3) 1 ml. of barium solution (20 mg. ml.^{-1}) was added to the

solution from step 2 and the precipitate which formed was slurried with 2 ml. of water, 2 ml. saturated boric acid and 2 ml. of concentrated nitric acid to effect its solution. The zirconium was then re-precipitated by the addition of 0.5 ml. of barium solution and 0.25 ml. of HF.

(4) The dissolution and precipitation were repeated as in step (3).

(5) The precipitate was dissolved in 2 ml. of water, 2 ml. of saturated boric acid and 2 ml. of 6M hydrochloric acid and zirconium hydroxide precipitated by the addition of 5M sodium hydroxide.

(6) The zirconium hydroxide was washed with water and dissolved using 3 ml. of concentrated hydrochloric acid and 3 ml. of water. The solution was transferred to a glass test tube, heated on the water bath and 10 ml. of 15% mandelic acid solution added; heating was continued for 20 minutes to complete the precipitation of zirconium tetramandelate. This precipitate was mounted on a filter disc and washed successively with a 5% solution of mandelic acid in ~~20%~~ hydrochloric acid, ethanol and ether.

(b) From protactinium

(1) to (5) As for uranium.

(6) The hydroxide precipitate was washed with water,

dissolved in concentrated hydrochloric acid with the addition of the minimum of water and transferred to a separating funnel with more acid. An equal volume of diisobutyl ketone (previously equilibrated with concentrated hydrochloric acid) was added, the funnel shaken for 3-4 minutes and the organic phase discarded; a fresh portion of DIBK was added and the extraction repeated.

(7) The aqueous phase was heated to expel the remaining DIBK and zirconium precipitated by the addition of 5M sodium hydroxide. The precipitate was washed with water, dissolved in hydrochloric acid and zirconium tetramandelate precipitated as described above.

(2) Barium.

Carrier Solution

A weighed amount of dried barium carbonate was dissolved in the minimum volume of dilute hydrochloric acid and made up to the appropriate volume with water.

Separation Procedure

(1) An acid solution of the catcher foils was made alkaline and solid sodium carbonate added to ensure the precipitation of barium carbonate. The precipitate was washed free of sodium carbonate, dissolved in the minimum volume of 6M

hydrochloric acid and cooled in ice. 20 ml. of a 5:1 mixture of concentrated hydrochloric acid and ether was added, the solution vigorously stirred and left for a few minutes to complete the precipitation.

(2) The barium chloride precipitate was dissolved in the minimum volume of water and re-precipitated with hydrochloric acid and ether.

(3) Step 2 was repeated and the precipitate collected on a filter disc. It was washed successively with ethanol, 4% in aqueous hydrochloric acid and then ether before drying under vacuum.

(3) Bromine

Carrier solution

Dry potassium bromide was weighed out and dissolved in water.

Separation Procedure

(1) An alkaline solution of the catcher foils was cooled in ice and cautiously acidified with hydrochloric and nitric acids without allowing the temperature to rise. After the addition of 6-8 drops of saturated ceric sulphate solution the bromine was either distilled in a current of nitrogen into ferrous sulphate solution or extracted directly into carbon tetrachloride. If distillation was used the

solution in the receiver was acidified and bromine extracted into carbon tetrachloride after oxidation with a few drops of saturated potassium permanganate solution.

(2) The carbon tetrachloride extract was transferred to a clean separating funnel and the bromine back extracted into water to which had been added a few drops of a saturated solution of sulphur dioxide. 2 ml. of iodine carrier were added to the acidified aqueous phase and iodine oxidised by the addition of 0.1 M sodium nitrite before extraction into carbon tetrachloride. The extraction was repeated once more.

(3) The bromine was oxidised with permanganate, extracted into carbon tetrachloride and back-extracted into water containing a little saturated sulphur dioxide solution. The aqueous phase was boiled to drive off excess sulphur dioxide and bromine precipitated as silver bromide. This precipitate was collected and washed with water, ethanol and ether.

(4) Strontium

Carrier solution

Strontium nitrate was dissolved in water and standardised by the precipitation of strontium oxalate by the method used for the preparation of the fission product sources.

Separation Procedure

- (1) An acid solution of the catcher foils was made alkaline with strong sodium hydroxide solution and a little solid sodium carbonate added to complete precipitation of strontium as carbonate. This precipitate was dissolved in the minimum volume of dilute nitric acid, the solution cooled in ice and strontium reprecipitated by the addition of 20 ml. of fuming nitric acid.
- (2) The strontium nitrate was dissolved in the minimum volume of water and reprecipitated by the addition of 15 ml. of fuming nitric acid to the cooled solution: this precipitate was dissolved in water, 1 ml. of iron carrier added and ferric hydroxide precipitated by the addition of 6M ammonia.
- (3) 2 ml. of barium carrier were added to the supernate, the solution neutralised with 6M nitric acid and buffered by the addition of 1 ml. of 6M acetic acid and 2 ml. of 6M ammonium acetate. Barium chromate was precipitated by the addition of 1 ml. of 1.5 M sodium chromate and heating to boiling. This precipitate was discarded, more barium carrier added and barium chromate again precipitated.
- (4) 2 ml. of concentrated ammonia were added to the supernate the solution heated almost to boiling and strontium oxalate precipitated from hot solution by the addition of saturated ammonium oxalate solution. The oxalate was collected on a filter disc and washed with hot water, ethanol

and ether.

(5) Yttrium

Carrier solution

Yttrium nitrate was dissolved in water and standardised by titration with EDTA using xylenol orange as indicator.¹¹⁴

Separation Procedure

(1) An acid solution of the catcher foils was made alkaline with sodium hydroxide solution when yttrium hydroxide was precipitated. The precipitate was dissolved in 6M nitric acid, 2 ml. of cerium (III) carrier added and hydroxides precipitated by the addition of 6M ammonia.

(2) The hydroxide precipitate was dissolved in 6M nitric acid, diluted to 10 ml. with water, 1 ml. zirconium carrier added and the solution transferred to a polythene test tube. It was made 4M in HF and the supernate discarded. The precipitate was washed with 10 ml. of 4M HF dissolved in 2 ml. of saturated boric acid with the aid of 2 ml. of concentrated nitric acid and the solution diluted to 10 ml. One ml. of zirconium carrier was added and yttrium and cerium fluorides precipitated by the addition of HF.

(3) The fluorides were dissolved as in the previous step and the solution made alkaline with concentrated ammonia. The precipitated hydroxides were dissolved in 50 ml. of concentrated nitric acid, transferred to a separating funnel

and shaken for 5 minutes with 10 ml. of T.B.P. reagent (60% (v/v) tri-n-butyl phosphate in petroleum ether equilibrated with concentrated nitric acid). The aqueous phase was discarded, and the T.B.P. washed twice by shaking for 2 minutes with 50 ml. of concentrated nitric acid. Yttrium and cerium were back extracted by successive treatment with three portions each of 10 ml. of water.

(4) The aqueous phase was made alkaline with 6M ammonia to precipitate the hydroxides and the remainder of step 3 repeated. The hydroxide precipitate was then dissolved in 1 ml. of concentrated nitric acid, 2 drops of 40% HBr and 2 ml. of 15% sodium bromate. On dilution to 20 ml. with water and cooling in ice ceric iodate was precipitated by the addition of 0.35 M iodic acid; the precipitate was discarded following a suitable time interval (10 minutes) to ensure completeness of precipitation.

(5) Yttrium hydroxide was precipitated from the supernate with 6M ammonia, the precipitate was dissolved in 2 ml. of 6M hydrochloric acid, the solution diluted to 10 ml. with water, transferred to a clean test tube and the hydroxide reprecipitated by the addition of 6M ammonia.

(6) The hydroxide was dissolved in 2 ml. of 6M hydrochloric acid, diluted with water to 10 ml. and yttrium oxalate precipitated by the addition of saturated ammonium oxalate and boiling the mixture for 10 minutes. The precipitate

was mounted on a filter disc and washed with water, ethanol and ether.

(6) Molybdenum

Carrier solution

Ammonium molybdate was dissolved in water, with the addition of hydrochloric acid and sodium bromate; the solution was standardised by precipitation of molybdenum oxinate by the method used for the preparation of the fission product sources.

Separation Procedure

(1) An acid solution of the catcher foils was adjusted to 1-2M in acid and 5 ml. of a 2% alcoholic solution of α -benzoinoxime added; molybdenum precipitation was complete on standing for about 10 minutes. After washing with 30 ml. of water the precipitate was dissolved in 3 ml. of fuming nitric acid and dilute with water to 25 ml. Molybdenum was then reprecipitated after the addition of 1 to 2 ml. of concentrated ammonia and 5 ml. of α -benzoinoxime solution.

(2) The dissolution and precipitation of molybdenum was repeated after which the final precipitate was dissolved in 3 ml. of fuming nitric acid and boiled with 3 ml. of 60% perchloric acid. After cooling the solution was diluted to 10 ml. with water and 1 ml. of iron carrier added; ferric hydroxide was precipitated by the addition of

concentrated ammonia.

(3) The supernate was made just acid to methyl red with 5N sulphuric acid, 5 ml. of 2M ammonium acetate added and the solution heated to 90°. Molybdenum was precipitated by the addition of a slight excess of a 3% solution of 8-hydroxyquinoline; heating was continued until the precipitate coagulated. It was mounted, washed with hot water, ethanol and ether.

(7) Ruthenium

Carrier solution

Ruthenium chloride was dissolved in 1 M hydrochloric acid and standardised by the precipitation of ruthenium dioxide by the method used in the preparation of the fission product sources.

Separation Procedure

(1) An alkaline solution of the catcher foils was just acidified, 6-8 drops of saturated ceric sulphate solution added, the mixture boiled to promote exchange and ruthenium precipitated by the addition of hydrogen sulphide.

(2) The sulphide precipitate was slurried with 5N sulphuric acid, the suspension transferred to a distillation apparatus with the addition of more sulphuric acid. One g. of sodium bismuthate was added and ruthenium tetroxide

separated by distillation in a stream of nitrogen, collecting the product in 10 ml. of ice-cold, freshly prepared 12M sodium hydroxide. Distillation was continued until 1 to 2 ml. of liquid had passed over. The ruthenate solution was scavenged by the addition of 1 ml. of iron carrier.

(3) The supernate was transferred to a beaker, diluted to 25 ml. and made just acid. One ml. of freshly prepared 6 M sodium hydroxide was next added followed by 5 ml. ethanol, and ruthenium dioxide precipitated by boiling. The precipitate was slurried with about 10 ml. of water and boiled after the addition of 1 ml. of 6M sodium hydroxide. It was next filtered, washed with hot water, ethanol and ether and mounted for counting.

(8) Palladium-Silver

Carrier solutions

(a) Palladium. Palladium chloride was dissolved in 1M hydrochloric acid and the solution standardised by the precipitation of palladium bisdimethylgloxime as described in the preparation of the fission product sources.

(b) Silver. Dried silver nitrate was weighed and dissolved in water.

Separation Procedure

(1) An acid solution of the catcher foils was adjusted to 3

to 4M in acid and palladium precipitated by the addition of 2.5 ml. of a 1% alcoholic solution of dimethylglyoxime. After setting aside for 5 minutes the precipitate was transferred to a beaker, dissolved in hot concentrated nitric acid and diluted to 10 ml. with water.

(2) 1 ml. of iron carrier was added and ferric hydroxide precipitated by the addition of concentrated ammonia. Silver iodide was then precipitated by adding 1 ml. of silver carrier and potassium iodide solution; both precipitates were discarded and the scavenges repeated.

(3) The supernate was acidified with hydrochloric acid and palladium precipitated by the addition of 2.5 ml. of dimethylglyoxime solution. The precipitate was filtered, washed with water, ethanol and ether and dried.

(4) The weighed palladium precipitate was transferred to a beaker and dissolved in hot concentrated nitric acid. 2 ml. of silver carrier were added, the solution diluted to 10 ml. with water and left for a known time. Silver was then precipitated by the addition of one drop of 6M hydrochloric acid and the supernate set aside for the recovery of palladium.

(5) Silver chloride was dissolved in 3-4 drops of concentrated ammonia, the solution diluted to 5 ml. with water and two portions of ferric hydroxide precipitated from this solution.

These precipitates were discarded and the supernate acidified with 6M nitric acid; on the addition of one drop of 6M hydrochloric acid silver chloride was precipitated. It was mounted and washed with water, ethanol and ether.

(6) Palladium dimethylgloxime was precipitated, from the supernate from step (4) and collected as described in step 3. Silver was 'milked' from the palladium as described above at intervals until made impracticable by the decay of the latter.

(9) Silver

Carrier solution

Dried silver nitrate was weighed and dissolved in water.

Separation Procedure

(1) Silver chloride was precipitated by the addition of hydrochloric acid to a nitric acid solution of catcher foils or by the dilution of a hydrochloric acid solution.

It was dissolved in 3-4 drops of concentrated ammonia, 5 ml. of a 40% solution of EDTA added and silver precipitated with 1 ml. of a 2.5% ammoniacal solution of benzotriazole.

After leaving for about 5 minutes the precipitate was dissolved in 1 ml. of concentrated nitric acid and diluted to 20 ml.

(2) Silver was precipitated from this solution by the addition

of 1 drop of 6M hydrochloric acid and the silver chloride dissolved in ammonia. Silver was next re-precipitated with benzotriazole and the precipitate dissolved in nitric acid.

(3) After dilution the solution was made just alkaline with 6M ammonia and 3 drops added in excess to complete the precipitation of silver oxide. This precipitate was dissolved in 4 drops of concentrated sulphuric acid and evaporated to dryness. After cooling the residue was dissolved in 20 ml. of water and 1 ml. of 2M iodic acid added to precipitate silver iodate.

(4) The precipitate was dissolved in 4 drops of concentrated ammonia and the iodate re-precipitated by the addition of 3 drops of concentrated sulphuric acid and diluting the solution to 10 ml. with water. The precipitate was washed with water, ethanol and ether, dried and mounted for counting.

(10) Antimony

Carrier solution

Antimony trichloride was dissolved in hydrochloric acid and the solution standardised by titration with potassium permanganate.

Separation Procedure

(1) An acid solution of the catcher foils was boiled with bromine to oxidise antimony to antimony (V) and ensure exchange; antimony was precipitated by passing hydrogen sulphide into a hot solution 1 to 2 M in acid. The sulphide precipitate was dissolved in 2 ml. of 0.5M potassium hydroxide solution and scavenged twice by the precipitation of ferric hydroxide; the sulphide was re-precipitated by acidifying the solution.

(2) The precipitate was dissolved in 5 ml. of concentrated hydrochloric acid by boiling until the volume was reduced to 1 to 2 ml. After dilution to 10 ml. with concentrated hydrochloric acid the solution was transferred to a separating funnel together with 10 ml. of benzene, 1 ml. of iso propyl ether (equilibrated with concentrated hydrochloric acid) and 1 drop of bromine. The mixture was shaken for 10 seconds (during which time the organic phase remained brown showing that oxidation to antimony (V) was complete) and the organic phase washed with 1 ml. of 9M hydrochloric acid. Antimony was then back extracted into 10 ml. of 0.5 M hydrochloric acid containing a little solid hydrazine hydrochloride when both phases became colourless. The aqueous phase was washed with 25 ml. of iso propyl ether following the addition of solid potassium thiocyanate.

(3) A few drops of tellurium carrier were added and tellurium precipitated on heating. From the supernate antimony was precipitated in the elemental form by adding chromous chloride. The metal was washed with water, ethanol and ether, dried and mounted for counting.

(11) Tellurium

Carrier solution

Tellurous acid was dissolved in water and the solution standardised by precipitation of elemental tellurium by the method used to prepare the fission product sources.

Separation Procedure

(1) An acid solution of the catcher foils was boiled with 4 to 5 ml. of saturated potassium permanganate for several minutes; excess permanganate was removed by the addition of a few drops of hydrogen peroxide. The solution was boiled in the presence of hydrobromic acid to reduce the volume. 10 ml. of iron carrier were added and the solution made alkaline to precipitate both iron and tellurium. After dissolution of the precipitate in 6M hydrochloric acid tellurium was precipitated by adding a few drops of hydrazine hydrate, boiling the solution and passing sulphur dioxide.

(2) Tellurium was dissolved in the minimum volume of dilute nitric acid and the solution evaporated successively almost to dryness with two portions of 10 ml. of concentrated hydro-

chloric acid. After dilution to about 3M in acid tellurium was re-precipitated with hydrazine hydrate and sulphur dioxide.

(3) The treatment with nitric and hydrochloric acids was repeated the resulting solution diluted to 5 ml. with water and enough sodium hydroxide added to precipitate telluric acid and just re-dissolve it followed by 10 drops in excess. Two iron (III) scavenges were performed and the supernate acidified. Tellurium was precipitated as described in step (1) and the treatment with nitric and hydrochloric acids described in step 2 repeated.

(4) The precipitation of tellurium was repeated and the precipitate filtered, washed and dried for counting in the usual way.

(12) Cerium

Carrier solution

Cerium (III) nitrate was dissolved in water and the solution standardised by the precipitation of cerous oxalate by the method used for the preparation of the fission product sources.

Separation Procedure

(1) An acid solution of the catcher foils was boiled with 6-8 drops of saturated sodium bromate followed by 5 ml. of

6% hydroxylamine hydrochloride. On the addition of concentrated sodium hydroxide cerium was precipitated; this precipitate was dissolved in 6M hydrochloric acid, transferred to a polythene test tube, lanthanum and zirconium carrier added and the mixed fluorides precipitated by the addition of HF.

(2) The fluoride precipitate was washed with 15 ml. of water and dissolved in 1 ml. of saturated boric acid and 1 to 2 ml. of concentrated nitric acid, zirconium carrier was again added and fluorides re-precipitated, dissolved and again precipitated.

(3) The fluoride precipitate was then dissolved as before, transferred to a glass test tube, 2 ml. of 15% sodium bromate solution added, the solution cooled in ice, diluted to 15 ml. and ceric iodate precipitated by the addition of 20 ml. of 0.4M iodic acid. Precipitation was complete after about 10 minutes when the iodate was dissolved in a mixture consisting of 5 drops of 100 volume hydrogen peroxide, 1-2 ml. of concentrated nitric acid and 2 drops of 40% hydrobromic acid. After adding 2 ml. of sodium bromate and diluting to 20 ml. ceric iodate was re-precipitated.

(4) The precipitate was again dissolved in a mixture of hydrogen peroxide, nitric acid and hydrobromic acid. 2 ml.

of zirconium carrier were added and zirconium iodate precipitated by adding 20 ml. of iodic acid to the cooled solution. The supernate was made alkaline by the addition of pellets of sodium hydroxide when ceric hydroxide was precipitated. One ml. of concentrated hydrochloric acid was added followed by 15 ml. of water and the precipitate was dissolved by passing in sulphur dioxide. The solution was then heated to boiling and cerous hydroxide precipitated by the addition of 6M ammonia.

(5) The precipitate was dissolved in 1 ml. of 6M hydrochloric acid, diluted to 10 ml. with water, heated almost to boiling and cerium precipitated as the oxalate by the addition of 15 ml. of saturated oxalic acid. After heating for 10 minutes the oxalate was filtered, washed successively with water, ethanol and ether and dried for counting.

REFERENCES

1. E. Fermi, *Nature*, 133, 898 (1934).
2. O. Hahn and F. Strassmann, *Naturwiss.*, 27, 11 (1939).
3. L.A. Turner, *Rev. Mod. Phys.*, 12, 1 (1940).
4. L. Meitner and O. Frisch, *Nature*, 143, 239 (1939).
5. H. von Halban, F. Joliot and L. Kowarski, *Nature*, 143, 470 (1939).
6. C.D. Coryell and N. Sugarman, National Nuclear Energy Series, Div. IV Vol. 9. 'The Fission Products' 1951, McGraw-Hill, New York.
7. I. Halpern, *Ann. Rev. Nuclear Sci.*, 9, 245 (1959).
8. G.N. Walton, *Quarterly Reviews*, 15, 71 (1961).
9. E.K. Hyde, UCRL 9036, 9065, (1960).
10. L.W. Alvarez - reported by G. Farwell, E. Segrè and C. Wiegand, *Phys. Rev.*, 71, 327 (1947).
11. C.B. Fulmer and B.L. Cohen, *Phys. Rev.*, 108, 370 (1957).
12. L. Rosen and A.M. Hudson, *Phys. Rev.*, 78, 533 (1950).
13. K.W. Allen and J.T. Dewan, *Phys. Rev.*, 82, 527 (1951).
14. P. Demers. p. 357 "Ionographe; Les Emulsions Nucleaires". Montreal U.P., Ottawa, (1958).
15. D.J. Littler, *Proc. Phys. Soc.*, (London) A64, 638 (1951).
16. S. Katcoff, *Nucleonics*, 18, (No. 11), 201 (1960).
17. J.S. Fraser, *Phys. Rev.*, 88, 536 (1952).
18. G.R. Keepin, and T.F. Wimett, *Proc. Internat. Conf. Peaceful Uses of Atomic Energy*, Geneva, 1955, 4, (P/831).
19. N. Bohr and J.A. Wheeler, *Phys. Rev.*, 56, 426, (1939).

20. E. Segrè, Phys. Rev., 86, 21 (1952).
21. P.R. Fields et al. Phys. Rev., 102, 180 (1956).
22. R.E. Batzel and G.T. Seaborg, Phys. Rev., 82, 607 (1951).
23. W.E. Grummitt and G.M. Milton, J. Inorg. Nuclear Chem., 5, 92 (1958).
24. R.H. Goeckermann and I. Perlman, Phys. Rev., 76, 628 (1949)
25. L.E. Glendenin, C.D. Coryell and R.R. Edwards, ref. 6, Paper 52. p. 489.
26. D.C. Brunton and G.C. Hanna, Can. J. Res., 28A, 190 (1950).
27. E.P. Steinberg and L.E. Glendenin, Phys. Rev., 95, 431, (1954).
28. P.C. Stevenson, H.G. Hicks, W.F. Nervik and D.R. Nethaway, Phys. Rev., 111, 886 (1958).
29. W.M. Gibson, UCRL - 3493 (1956).
30. R.C. Jensen and A.W. Fairhall, Phys. Rev., 109, 942 (1958).
31. B.J. Bowles, F. Brown and J.P. Butler, Proc. Internat. Conf. Peaceful Uses of Atomic Energy Geneva, 1958. 15 P/6.
32. A.W. Fairhall, Phys. Rev., 102, 1335. (1956).
33. A.W. Fairhall, R.C. Jensen and E.F. Neuzil, ref 31, P/677.
34. R.C. Jensen and A.W. Fairhall, Phys. Rev., 118, 771, (1960).
35. R.L. Watters, Thesis. University of Seattle (1963) N.S.A. 18, 2844.
36. R.A. Nobles and R.B. Leachman, Nucl. Phys., 5, 211 (1958)
37. R.O. Griffioen, Thesis, Perdue University 1960. Reported in ref. 8 (Vol. 2) p. 75).
38. L.J. Colby. Thesis, Perdue University 1960. Reported in ref. 8 (Vol. 2) p. 56.

39. R.H. Iyer, C.K. Matthews, N. Ravindran. K. Rengan, D.V. Singh, M.V. Ramaniah and H.D. Sharma, *J. Inorg. Nuclear Chem.*, 25, 465 (1963).
40. H.G. Thode and R.L. Graham, *Can. J. Res.*, 25A, 1 (1947)
41. L.E. Glendenin, E.P. Steinberg, M.G. Inghram and D.C. Hess *Phys. Rev.*, 84, 860 (1951).
42. D.R. Wiles, D.W. Smith, R. Horsley and H.G. Thode, *Can. J. Phys.*, 31, 419 (1953).
43. L.E. Glendenin, *Phys. Rev.*, 75, 337 (1949).
44. D.R. Wiles and C.D. Coryell, *Phys. Rev.*, 96, 696 (1954).
45. R.K. Wanless and H.G. Thode, *Can. J. Phys.*, 33, 541 (1955).
46. D.M. Wiles, J.A. Petruska and R.H. Tomlinson, *Can. J. Chem.*, 34, 227 (1956).
47. A. Smith, P. Fields, A. Friedman, S. Cox and R. Sjoblom, *ref. 31*, P/690.
48. *ref. 7*. p. 318.
49. R.D. Hill, *Phys. Rev.*, 98, 1272 (1955).
50. W.J. Swiatecki, *Phys. Rev.*, 83, 178 (1951).
51. T.A.J. Maris, *Phys. Rev.*, 101, 502 (1956).
52. D.L. Hill, *ref. 31*, P/660.
53. D.R. Inglis, *Ann. Phys.*, 5, 106 (1958).
54. P. Fong, *Phys. Rev.*, 102, 434 (1956).
55. R.B. Duffield, R.A. Schmitt and R.A. Sharp, *ref. 31*, P/202.
56. J.M. Alexander and C.D. Coryell, *Phys. Rev.*, 108, 1274 (1957).
57. A. Turkevitch and J.B. Niday, *Phys. Rev.*, 84, 52 (1951).
58. A.N. Protopopov, Yu. A. Selitskii and S.N. Solov'ev, *Atomnaya Energiya*, 5, 659 (1958).

59. S.J. Lyle, G.R. Martin and J.E. Whitley, *Radiochimica Acta*, 3, 80 (1964).
60. M.V. Ramaniah and A.C. Wahl, *J. Inorg. Nucl. Chem.*, 24, 1185 (1962).
61. H.W. Kirby, *J. Inorg. Nucl. Chem.*, 18, 8 (1961).
62. D.A. Collins, J.J. Hillary, J.S. Nairn and G.M. Phillips, *J. Inorg. Nucl. Chem.*, 24, 441 (1962).
63. E. Bretscher and L.G. Cook, *Nature*, 143, 559 (1939).
64. B.I. Cohen, W.H. Jones, C.H. McCormick and B.L. Ferrell, *Phys. Rev.*, 94, 625, (1954).
65. G.N. Walton, *Prog. in Nucl. Phys.*, 6, 192 (1957).
66. R.H. James, G.R. Martin and D.J. Silvester, *Radiochimica Acta*, 3, 76 (1964).
67. J.G. Cuninghame, *J. Inorg. Nucl. Chem.*, 5, 1 (1957).
68. Nuclear Science Series, Reports on the Radiochemistry of the Elements. U.S. National Research Council.
69. L. Koch, *J. Nuclear Energy*, 2, 110 (1955).
70. J. Strong (in collaboration with others) "Procedures in Experimental Physics", Prentice-Hall Inc. 1938. Ch. IV.
71. K.M. Glover and P. Borrell, *J. Nuclear Energy*, 1, 214 (1955).
72. C. Ferradini, *J. Chim. Phys.*, 53, 714 (1955).
73. W. Forsling, Private communication.
74. W. Parker and R. Falk, *Nucl. Instr. and Methods*, 16, 355 (1962).
75. E.B.M. Martin, Handbook for Cockcroft-Walton Accelerator, Londonderry Laboratory for Radiochemistry
76. E.J. Wilson and C. Evans, *Atomics*, 9, 238 (1958).

78. R.L. Chase and W.A. Higinbotham, Rev. Sci. Instr.,
23, 34 (1952).
79. B.D. Pate and L. Yaffe, Can. J. Chem., 33, 15 (1955).
" " " 33, 610 (1955).
" " " 34, 265 (1956).
80. B.P. Bayhurst and R.J. Prestwood, Nucleonics, 17, (No. 3),
82 (1959).
81. D.N. Sunderman, AECU-3159, (1956).
82. R.B. Hahn and R.F. Skomieczmy, Nucleonics, 14 (No. 2),
56 (1956).
83. p. 328 of ref. 7.
84. B.L. Cohen, B.L. Ferrell-Bryan, D.J. Coombe and M.K.
Hullings, Phys. Rev., 98, 685 (1955).
85. I. Halpern and V.M. Strutinski, Paper P/1513 of ref. 31.
86. Nuclear Data Sheets, Nuclear Data Group, National
Research Council, Washington.
87. J.E. Sattizahn, J.D. Knight and M. Kahn, J. Inorg.
Nuclear Chem., 12, 206 (1960).
88. L.E. Glendenin, R.R. Edwards and H. Gest, p. 1451 of ref.
6.
89. M.V. Raminiah, Thesis, Washington University, 1956.
Quoted in ref. 87.
90. J. Kleinberg (ed.), LA-1566 (1953).
91. W.W. Wendlandt, Anal. Chem., 30, 58 (1958).
92. S.J. Lyle and Md. M. Rahman, Talanta, 10, 1183 (1963).
93. E.M. Scadden, Nucleonics, 15, (No. 4), 102 (1957).
94. E.C. Freiling and L.R. Bunney, Nucleonics, 14 (No. 9),
112 (1956).
95. R.P. Larsen, L.E. Ross and G. Kesser, ANL-5810 (1957).
96. L.E. Glendenin, Paper 265, p. 1575 in ref. 6.

97. A.C. Pappas, AECU-2806 (1953).
98. T.C. Hoering in "Brookhaven National Laboratory, Collected Procedures" (H.L. Finston ed.) 1956.
99. G.J. Hunter and M. Perkins, AERE-AM69.
100. E.P. Steinberg and L.E. Glendenin, Proc. Internat. Conf. Peaceful Uses of Atomic Energy, Geneva, 1955, 7, P/614.
101. T.J. Kennett and N.G. Thode, Phys. Rev., 103, 323 (1956).
102. A.C. Wahl, Phys. Rev., 99, 730 (1955).
103. B.M. Foreman, W.M. Gibson, R.A. Glass and G.T. Seaborg, Phys. Rev., 116, 382 (1959).
104. A.C. Pappas, P/881 of ref. 31.
105. C.D. Coryell, Ann. Rev. Nuc. Sci., 2, 305 (1953).
106. A.C. Wahl, J. Inorg. Nuclear Chem., 6 263 (1958).
107. A.C. Wahl, R.L. Ferguson, D.R. Nethaway, D.E. Trouter, and K. Wolfsberg, Phys. Rev., 126, 1112 (1962)
108. R.F. Coleman, B.E. Hawker and J.L. Parkin, J. Inorg. Nuclear Chem., 14, 8 (1960).
109. G.P. Ford and R.B. Leachman, Phys. Rev., 137, B826 (1965).
110. D.J. Hughes and R.B. Schwartz, BNL-325 (1958).
111. S.M. Dubrovina and V.A. Shigin, Dokl. Akad. Nauk. SSSR, 157, 561 (1964).
- ~~112.~~ (English translation-Soviet Physics, Doklady, 9, 579 (1965)).
113. J. Körbl and R. Pribil, Chemist-Analyst, 46, 28 (1957).
114. J. Kinnunen and B. Wennerstrand, Chemist-Analyst, 46, 92 (1957).
115. J.F. Emery, J. Inorg. Nuclear Chem., 27, 903 (1965).

116. A.B. Smith, R.G. Nobles and S.A. Cox, Phys. Rev., 115,
1242 (1959).
117. G.M. Smirenkin, I.I. Bondarenko, L.S. Kutsaeva, Kh.D.
Mischenko, L.I. Prokhorova, and
B.P. Shemetenko, At. Energiya, 4,
188, (1958).
118. M. Gaudin and J.L. Leroy, P/1186 of ref. 31.

ACKNOWLEDGEMENTS

I wish to record my thanks to the following:

Dr. S.J. Lyle for his supervision and interest throughout the course of this work.

Professor G.R. Martin for advice and discussion on various topics.

Mr. R.J. Oliver for running the neutron generator and for general technical assistance.

The Department of Scientific and Industrial Research for the award, for one year, of an advanced course studentship.

The Council of the Durham Colleges for the award, for two years, of a research studentship supported from an Extra-Mural Research contract between the Atomic Energy Research Establishment, Harwell, and the University.

