



## Durham E-Theses

---

### *The application of neon flash tubes to studies of cosmic rays*

Holroyd, F. W.

#### How to cite:

---

Holroyd, F. W. (1971) *The application of neon flash tubes to studies of cosmic rays*, Durham theses, Durham University. Available at Durham E-Theses Online: <http://etheses.dur.ac.uk/8681/>

#### Use policy

---

The full-text may be used and/or reproduced, and given to third parties in any format or medium, without prior permission or charge, for personal research or study, educational, or not-for-profit purposes provided that:

- a full bibliographic reference is made to the original source
- a [link](#) is made to the metadata record in Durham E-Theses
- the full-text is not changed in any way

The full-text must not be sold in any format or medium without the formal permission of the copyright holders.

Please consult the [full Durham E-Theses policy](#) for further details.

THE APPLICATION OF NEON FLASH TUBES  
TO STUDIES OF COSMIC RAYS

A Thesis submitted  
to the  
University of Durham  
for the  
Degree of Doctor of Philosophy

by

F.W.Holroyd B.Sc.

September 1971



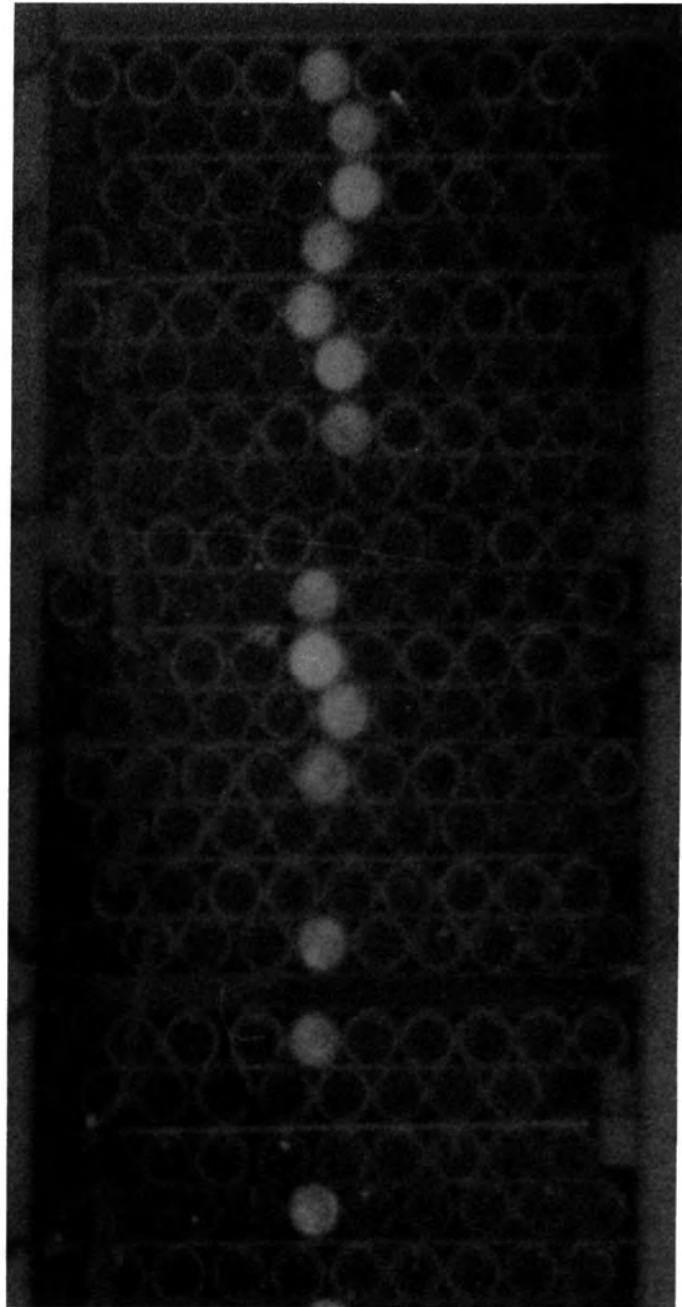

## CONTENTS

	page
Abstract	4
Chapter 1	<u>Cosmic Rays and their Detection</u> 5
Chapter 2	<u>Characteristics of the Neon Flash Tube</u> 15
2.1	Introduction 15
2.2	Spatial Resolution 15
2.2.1	Experimental Investigation 15
2.2.2	Theoretical Investigation 17
2.3	Efficiency 17
2.3.1	Applied Fields 18
2.3.2	Rise Time 19
2.3.3	Nature of the Gas 19
2.3.4	Purity of the Gas 19
2.3.5	Pressure of the Gas 20
2.3.6	Delay 20
2.4	Anomalous Flash Tube Results 21
2.4.1	Efficiency versus Delay 21
2.4.2	Efficiency versus Applied Field 22
2.4.3	Efficiency versus Repetition Rate 22
2.4.4	Spurious Flashing 22
2.4.5	After Flashing 23
2.5	Possible Explanations 23
2.6	Conclusion 24
Chapter 3	<u>Experimental Investigation of Clearing Fields</u> 25
3.1	Introduction 25
3.2	The Flash Tube Pulsing System 25
3.3	Evidence for Clearing Fields 27
3.4	External Clearing Fields 28
3.5	Two Clearing Field Effects 28
3.6	The Short Term Clearing Field Effect 29
3.7	The Nature and Cause of Clearing Fields 29
3.8	Decay of the Clearing Fields 30
3.9	Artificial Means of removing the Clearing Fields 31
3.10	Stannic Oxide Coated Tubes 32
3.11	Tubes with High Water Content 32
3.12	Bipolar Ringing Pulses 33
3.13	Long Term Clearing Field Effect 34
3.14	Dependence of Long Term Effect on Applied Field 34
3.15	Summary 35

	page
Chapter 4	<u>The Discharge Mechanism in Flash Tubes</u> 37
4.1	Introduction 37
4.2	Apparatus 37
4.3	The Discharge Mechanism 38
4.4	Probability of a Discharge Occurring 39
4.5	The Magnitude of the Discharge 39
4.6	Propagation of the Discharge down the Tube 40
4.7	The Digitisation Pulse 42
4.8	Back Discharging 44
4.9	Summary 44
Chapter 5	<u>Theoretical Considerations Regarding Flash Tube</u>
	<u>Efficiency</u> 46
5.1	Introduction 46
5.2	Diffusion 47
5.3	The Random Walk Method 49
5.4	Formative Distance 50
5.5	Drift Velocity 51
5.6	Position of the Track in the Flash Tube 52
5.7	Determination of Drift Velocities built up in the Experiments 52
5.8	Decay of the Clearing Fields 53
5.9	Conclusion 55
Chapter 6	<u>Discussion</u> 56
6.2	Production of Electrons in Flash Tubes 56
6.3	The Discharge 57
6.4	Clearing Fields 59
6.5	The Long Term Clearing Fields 61
6.6	External Clearing Fields 63
6.7	Attempts to Overcome the Clearing Field Effect 64
6.8	Recovery Time 66
6.9	Conclusion 66
6.10	Further Experiments 68
Appendix 1	<u>The Design of the M.A.R.S. Magnet</u> 70
References	73
Acknowledgements	78

- 4 -

ABSTRACT

A study has been made of the characteristics of neon flash tubes with a view to their use in cosmic ray work, and for machine experiments. In particular their low efficiency when operated at high repetition rates has been investigated, and this is thought to be due to fields set up by charge deposited on the glass as a result of the discharge. The fields are shown to decay with a time constant consistent with conduction of electrons over the glass surface to neutralise positive ions deposited on the other side of the tube. A long term effect has also been encountered, and is thought to be due to fields caused by electrons trapped in the glass.

The discharge mechanism has been examined and shown to be, in most cases, a combination of streamer and Townsend breakdown. The most probable method of propagation down the tube is that several discharges are initiated along the tube by photoemission from the walls caused by photons from the initial and successive avalanches. When the field due to charge separation effectively backs off the applied field, the discharge is quenched.

A random walk method has been developed to solve the equation of diffusion and drift for electrons in a flash tube, taking formative distance into account, and hence the fields built up during the experiment have been estimated, and compared with values calculated from the decay constant obtained from the resistivity of the glass and the capacitance of the tube.

Some methods of overcoming the clearing field effect, namely increased surface conductivity, and the use of a bipolar ringing pulse, have been successfully tried, with a view to making the efficiency of flash tubes independent of repetition rate.

CHAPTER 1.

COSMIC RAYS AND THEIR DETECTION.

The first evidence for the existence of cosmic radiation was obtained at the end of the last century in experiments to measure the conductivity of gases. It was found that, even when the apparatus was shielded from all known sources of radiation, the gas still showed some conductivity, although it was thought at that time that gases should be almost perfect insulators. The conclusion therefore was, that some unknown source of ionising radiation was present.

This radiation was at first attributed to radioactive materials in the earth's crust, but when ionisation chambers, sent up in balloons, detected a decrease in the intensity of the radiation with altitude up to about 700 metres, and an increase above this height, it was inferred that at least some of the radiation came from outside the earth. It was further concluded that the radiation was not of solar origin since no variation in intensity was observed between daytime and night time measurements, although variations have since been detected which show that some of the low energy radiation comes from the sun and is particularly associated with intense solar activity.

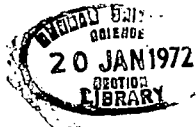

The fact that cosmic radiation causes ionisation of gases, thus increasing their electrical conductivity, provided the first indication of its existence, and this property has been utilised in several instruments for the detection and study of cosmic rays.

One of these instruments, the Geiger counter, has been used in many early cosmic ray experiments. It consists of a gas filled cylindrical cathode with a fine wire anode running down its centre. When a particle passes through the gas, ionisation occurs along its path. The electrons are swept by the electric field to the anode, causing further ionisation in the gas, and the positive ions move more slowly to the cathode. Breakdown of the gas results, and an electrical pulse is obtained from the anode.

Using Geiger counters, Bothe and Kolhörster in 1928 (1) were able to show that at least some of the cosmic radiation was due to charged particles. Up to this time it had been assumed that the radiation was due to high energy gamma rays, the most penetrating radiation then known.

The apparatus of Bothe and Kolhörster consisted of an array of counters and a coincidence circuit which required simultaneous signals from two counters, showing that a particle and not a gamma ray had traversed the system.

Such arrays can be used to find the actual path of a particle, whereas the ionisation chamber simply detected the presence of radiation.

Similar arrangements have been employed to study the directional variations of cosmic rays. A difference in intensity from East and West was found, and by considering the deflection of charged particles in the earth's magnetic field this was shown to indicate an excess of positively charged particles.

Related to the Geiger counter is the proportional counter. This has a lower voltage on its electrodes, so that when a particle passes through it a catastrophic discharge does not occur, but the pulse height is proportional to the initial ionisation. Information can be obtained not only about the position but also about energy loss, and therefore about the nature of the particle.



Another detector which makes use of ionisation and which has been employed in many cosmic ray experiments is the cloud chamber, devised by C.T.R. Wilson in 1912. This instrument consists of an expandable chamber filled with a gas and a saturated vapour. Ionisation is caused by a particle along its path, and if the chamber is then expanded the vapour becomes supersaturated and the ions act as condensation nuclei. The vapour drops formed along the tracks are visible in a bright light and can be photographed. Typical tracks in a cloud chamber are 1 or 2 mm wide and hence particle trajectories can be located with much greater accuracy than with arrays of Geiger counters, and the finer details of the track such as scattering, delta rays and tracks of interaction products can be seen.

In 1932 Anderson, studying cosmic radiation with a cloud chamber operated in a strong magnetic field, demonstrated the existence of the positron, a positive particle with mass about the same as the mass of the electron. (2)

It was also in cloud chamber experiments that the soft or non-penetrating component of cosmic radiation was shown to consist mainly of electrons and positrons, and the hard or penetrating component, of charged particles with mass about 200 times the electron mass.

Initially it was thought that this might be the Yukawa particle which had been proposed to explain nuclear forces, but since the Yukawa particle was expected to interact strongly with matter, and the cosmic ray particle was found not to do so, it was inferred that the two were not the same. The cosmic ray particle was later called the  $\mu$  meson or muon.

Besides these two main components of cosmic radiation, the cloud chamber has made it possible to identify many other elementary particles, both as cosmic rays and as products of interactions between the primary cosmic rays and the atmosphere, or with targets placed in their path. For example, in a cloud chamber experiment in 1947 Rochester and Butler observed the decay of a neutral hyperon (3) and in 1969 McCusker et. al., making use of the fact that the density of vapour drops along a

track is proportional to the ionisation, used the cloud chamber to look for particles with fractional charge, and found possible evidence of quarks. (4)

Unfortunately the accuracy of track location in the cloud chamber is limited by movement of the gas and consequent track distortion. Another drawback is the necessarily long time, about 15 m.sec. between the passage of the particle and the formation of the vapour drops. This is due to the mechanical process of expanding the chamber and gives the ions time to diffuse away from their original positions, and leads to added inaccuracy because of the broadening of the tracks.

The cloud chamber is a rather complicated device, but another, much simpler technique, the nuclear emulsion, which gives a record of actual particle tracks and interactions, has been widely used in cosmic ray work since about 1947. If an ionising particle passes through a block of photographic emulsion which is subsequently developed, the track of the particle becomes visible. The density of the track, i.e. the number of grains per unit length, is proportional to the ionisation, and the range of the particle in the emulsion is related to its energy. This technique is useful for balloon and satellite experiments because the emulsion is very light, it is simple and reliable and needs no ancillary equipment. However, its temporal resolution is extremely poor, and it is tedious to scan.

Both the cloud chamber and nuclear emulsion can be used only over relatively small areas. The spark chamber, introduced about 1960 has comparable accuracy of track location, and can be used over much larger areas. Since it does not rely on any mechanical process the delay between the passage of a particle and the formation of a visible track can be as little as a few hundred n.sec., and the device is more reliable and simpler to operate than the cloud chamber.

The spark chamber consists of two parallel plane electrodes with a gas, usually neon, between them. As in the Geiger counter, a particle passing through causes ionisation and hence breakdown of the gas. The discharge is localised at the point where the

particle passed through the chamber, and can be recorded photographically, and by using many spark chambers, one above the other, or multiplate spark chambers, the particle trajectories can be defined. Spark chambers are relatively cheap and have made possible the study of cosmic rays over large areas. They have been used in conjunction with magnets to determine the spectrum of cosmic ray muons up to high momenta where a large volume of detector is needed.

The device can be triggered by a network requiring a coincidence from two scintillation counters above and below the chamber. In this way a voltage pulse much greater than breakdown voltage can be applied soon after the passage of the particle. This method is found to give more reliable results than the application of a D.C. voltage just below breakdown potential.

Current limited spark chambers are chambers which have the gas enclosed in a glass envelope with the electrodes on the outside. Because of the insulating layer of glass the current in each spark is limited, and hence one spark does not "rob" another, and the multitrack efficiency of the device is increased, making possible the study of air showers and interactions of cosmic ray particles.

If the electrodes are made of parallel wires instead of sheets of metal, the position of the particle can be read out electronically since a current pulse is obtained in the wire to which the discharge occurred. Electronic readout enables experiments to be run on line to a computer, saving much tedious scanning of film, and allowing large amounts of data to be processed, which would otherwise take too long to analyse.

A further development of the spark chamber technique is the streamer chamber. This consists essentially of a wide gap spark chamber to which a very short high voltage pulse is applied soon after the passage of a particle. The pulse is so short that the avalanche initiated by each electron has not had time to travel right across the chamber before the pulse is removed, thus streamers are formed along the actual path of the particle instead of a spark between the electrodes.

A very recent variation of the gaseous detector is the multi wire proportional chamber, which is constructed like a spark chamber with parallel wire electrodes giving a more uniform field than that in the proportional counter, and a D.C. voltage below breakdown potential is applied to it. Ions produced by a particle are swept to the nearest wire, and as in the proportional counter, the resulting pulse height is proportional to the initial ionisation.

At present proportional chambers are used mainly to determine the number of particles passing through a system, but they can also be used for track location and energy loss measurements.

It has been mentioned that detectors like cloud chambers and spark chambers can be triggered, when a particle has passed through them, by a coincidence signal from two scintillation counters. These counters consist of a piece of material which has the property that when a charged particle passes through it excitations can occur which decay with the emission of visible light. This can be detected by a photomultiplier. The response from a scintillation counter can be very fast; a few n.sec., an obvious advantage if a detector is to be triggered as soon as possible after a particle has passed through it.

Scintillation counters have another application in energy loss measurements. The height of the light pulse is proportional to the energy lost in the scintillator. This provides a convenient method for measuring the size of extensive air showers. Since the energy lost in the scintillator is roughly proportional to the number of particles passing through it, the pulse heights from an array of scintillators give some indication of the size of the shower.

Another detector which is sometimes used in triggering circuits is the Cerenkov counter. When a particle passes through a medium with a velocity greater than the velocity of light in the medium, light is emitted in a forward cone, the angle of which depends on the velocity of the particle; thus the direction and velocity of the particle can be determined. By choosing a medium with a suitable refractive index, particles with different velocities can be distinguished since particles are recorded only if their velocity is greater than the velocity of light in the medium. Cerenkov counters are much cheaper

than scintillators since water can be used as the medium, but the light output is very much lower.

A comparatively recent instrument for cosmic ray studies is the flash tube chamber, proposed by Conversi and Gozzini in 1955 (5) as a result of work by Focardi et al. on plane counters and fast triggering circuits for them (6)

The flash tube chamber consists of several layers of glass tubes filled with neon, covered with black paint or other opaque material, and placed between electrodes. When a particle passes through the gas ionisation takes place, and if a high voltage pulse is then applied the ions are accelerated in the field and a luminous discharge occurs. The tubes along the path of the particle lights up and can be photographed. This instrument has many advantages over other detectors and has been widely used in cosmic ray work.

The flash tube chamber is robust, very simple and reliable and easy to operate. The tubes have a long life, and can be manufactured very cheaply using commercial neon, and they can be used over very large volumes without difficulty in the pulsing system being experienced. They have the added advantage over virtually every other type of detector, of consisting of small units which can easily be rearranged for use in several different experiments.

The device can be triggered by a coincidence network incorporating scintillation counters, thus allowing a high voltage pulse higher than breakdown potential to be applied. Unlike spark chambers, which require short fast rising pulses, flash tubes will work efficiently over a wide range of pulse parameters. The internal efficiency, defined as the probability of a particle which passes through the gas causing a flash, can be very close to 100% provided the delay between the passage of the particle and the application of the high voltage pulse is less than about 5 micro sec. Applied fields as low as 1 or 2 KV/cm., which is much lower than the fields of about 5 KV/cm required for spark chambers, can be used, and pulse lengths can vary from a few hundred n.sec., to tens of micro secs., with rise times of up to a micro sec., without any significant loss of efficiency.

Flash tubes have a much longer sensitive time than spark chambers. Delays of several tens of micro secs between the passage of a particle and the application of the high voltage pulse can be tolerated. This, however, can be a disadvantage if very high repetition rates are to be used, since old tracks may be mistaken for tracks simultaneous with the one which triggered the instrument. This difficulty can be overcome by the application of a clearing field which sweeps the ions from old tracks out of the tube before the next event.

Good multi track efficiency is another advantage of the flash tube chamber. If more than one particle traverses the apparatus the efficiency of one track is not reduced by the presence of the others. Since the gas is insulated from the electrodes the current in the discharge is limited and the flashing or otherwise of one tube does not influence the others. Flash tubes therefore have an advantage over the conventional spark chamber where the current is not limited and one spark may develop at the expense of the others.

If many layers of flash tubes are used particle trajectories can be defined with great accuracy, and if the tube diameter is reduced even better resolution can be obtained. Tubes of 0.5 to 1.5 cm. are generally used and, for arrays of several layers, track location of about 1 mm. accuracy has been claimed. This is comparable with the accuracy which can be achieved with cloud chambers and spark chambers. A three dimensional reconstruction of particle trajectories can be obtained by arranging the flash tubes with alternate layers at right angles to each other.

Flash tubes have an advantage over other detectors where photography is employed in that the whole tube lights up, and therefore no depth of focus problems are encountered. Another advantage is that the light output from the tubes is high, and specially sensitive film is not required.

An electronic readout from flash tubes can be used as an alternative to photography, enabling experiments to be run on line to a computer. There are two basic methods; one is to place a photosensitive cell in front of each tube to detect the light emitted by the discharge, and the other is to place a metal probe in front of each tube to pick up the electronic

pulse which is found to accompany the discharge. (7) Electronic readout can also be obtained from wire spark chambers, but for the same accuracy of track location and the same volume of detector, flash tubes are a much cheaper method.

The spectrum of cosmic ray muons has been measured using flash tubes in conjunction with magnets. Muons, being charged particles, are deflected in a magnetic field. The flash tubes are placed in layers on either side of the magnet, or in the case of the M.A.R.S. experiment, in gaps between the sections of the magnet. (see appendix 1) The track of the muon is recorded by the flash tubes, and its momentum determined from its deflection in the magnetic field of known strength. In the M.A.R.S. project (8) the muon spectrum up to 5,000 GeV/C is to be measured, using an electronic readout system. Similar apparatus is used to determine the ratio of positive to negative muons as a function of muon energy.

The search for neutrinos deep underground has also utilised the flash tube chamber (9). In this experiment all cosmic rays except neutrinos are absorbed by the rock. The tracks of two secondary particles, recorded by the flash tubes, which when projected backwards, intersect somewhere in the surrounding rock, indicate that a penetrating cosmic ray neutrino has interacted with a rock molecule at this point.

Extensive air shower work is another branch of cosmic ray physics which has employed the flash tube chamber (10,11). In the study of air showers large volumes of detector are needed, and many particles must be recorded at the same time. Flash tubes are therefore very suitable for this application.

In the above experiments flash tubes are used simply to define the tracks of cosmic ray particles, and the requirements are high efficiency, good resolution and reliability. A different property of flash tubes is being exploited at present in the Durham Quark experiment (12). This experiment relies on the fact that the ionisation produced in a flash tube, and therefore, under certain conditions, the efficiency, depends on the charge of the ionising particle. Thus a quark with charge  $\frac{1}{3}$  or  $\frac{2}{3} e$  would be expected to produce a less efficient track

in a flash tube array than a particle, for example a muon, with charge  $1 e$ .

The flash tube chamber has found increasing use in cosmic ray studies in recent years, and its possible application to machine experiments has been suggested. Much work has been done on the properties of flash tubes and this is summarised in the next chapter. This thesis consists of further research into the mode of operation and characteristics of flash tubes, particularly some factors influencing the efficiency of the tubes which are not fully understood and which are important in some present and future applications of the device.



## CHAPTER 2.

### CHARACTERISTICS OF THE NEON FLASH TUBE.

#### 2.1. INTRODUCTION.

This chapter contains a summary of the investigations which have been made into the mode of operation and characteristics of flash tubes. For most applications of the flash tube chamber up to the present time, the chief requirements are good resolution and high efficiency.

#### 2.2. SPATIAL RESOLUTION.

If flash tubes are to be used for defining particle trajectories it is important that good spatial resolution can be obtained. This problem has been studied both from an experimental and a theoretical point of view.

##### 2.2.1. EXPERIMENTAL INVESTIGATION.

The resolution of flash tube arrays has been investigated experimentally by Ashton et al. in 1958. (13). These workers used staggered stacking instead of tubes stacked vertically above each other as in the original apparatus of Conversi and Gozzini, since the latter arrangement leads to a situation in which a verticle particle is able to pass through the dead spaces between the tubes and not cause any flashes. They found that the overall efficiency, defined as the ratio of the number of useable photographs to the total number taken, was improved, and

the precision with which a track could be located was slightly increased.

Four trays of flash tubes A,B,C and D were used. The position of a track at each of the four levels was found from the tubes which flashed, and the angle between the lines AB and CD was determined. The tracks of particles passing through the stack were measured by three methods:-

- a) The centre of gravity of the centres of the tubes which flashed at each level was found, and the inclination of the line joining the two points was determined.
- b) A diagram of the array was drawn and a thread was adjusted over its surface to give the best straight line through the flashed tubes.
- c) Photographs of the events were projected onto a rotatable screen with close parallel lines ruled on it and the direction of the line determined such that the sum of the distances from the centres of the flashed tubes to the line was a minimum.

Flashes which were incompatible with a track defined by the other flashes were rejected.

Ashton and his co workers concluded that the last two methods are superior to the first but that there is little difference between these two.

The distribution in angle found from the measurements was  $0.33^\circ \pm 0.02^\circ$ . The angle can be due to four causes:-

- a) Scattering of the particles.
- b) The error in setting the measuring device on the best estimate of the track.
- c) The error in defining the track.
- d) Traversal of the array by more than one particle, for example, knock on electrons produced by the primary particle, when it may not be obvious to which track a given flash belongs.

It was concluded that the errors due to scattering, setting the measuring device and other causes were:-

$0.22^\circ$ ,  $0.14^\circ$  and  $0.2^\circ \pm 0.03^\circ$  respectively.

Also calculated was the uncertainty of the position of the trajectory at a single level, although it was pointed out that this was less than the uncertainty at a single level considered independently of the others. The value of this uncertainty was found to be:-

$$\delta = 0.62 \text{ mm} \pm 0.1 \text{ mm}$$

for the array used in this experiment.

The conclusions drawn from this work were that the error in track location due to spurious flashes caused, for example, by knock on electrons, is small, and that the accuracy for the array is comparable to that which can be obtained in a cloud chamber, where tracks can be located with an accuracy of about 1 mm.

#### 2.2.2. THEORETICAL INVESTIGATION.

A theoretical investigation into the accuracy of track location in flash tube arrays has been carried out by Bull et al. (14) who have devised a computer method for analysis of flash tube data. (15). They concluded that, experimentally, the error of location does not decrease as rapidly with increasing number of layers as the theory indicates; that high pressure tubes being more efficient, give greater accuracy of track location, and that there is no advantage in increasing the vertical separation of the layers.

#### 2.3. EFFICIENCY.

The basic mechanism of flash tube operation was described by Conversi et al. (16) When a flash tube is traversed by a charged particle, ionisation of the gas occurs along the track. If a high voltage pulse is subsequently applied the electrons freed by the particle are accelerated in the electric field and a luminous discharge results. It is assumed that if at least one electron is present in the gas when the pulse is applied, the tube will flash. An equation is given for the efficiency of a flash tube:-

$$\eta = 1 - \text{EXP} ( -Q (D - D_f) )$$

where  $\eta$  = efficiency  
 $Q$  = number of electrons /cm generated by the particle.  
 $D$  = average path length of a particle in the tube  
 $D_f$  = formative distance, or path length necessary for an electron avalanche to develop into a discharge.

The internal efficiency of a flash tube can be defined as the probability of a luminous discharge occurring when a particle has passed through the gas. The layer efficiency of an array of flash tubes, which is the quantity usually measured in practice, is the ratio of the number of layers in which a flash is observed along the path of the particle, to the total number of layers. This is related to the internal efficiency by the equation:-

$$\eta_L = \frac{d_i}{d_e} \eta_i$$

where  $\eta_L$  = layer efficiency.  
 $\eta_i$  = internal efficiency.  
 $d_i$  = internal diameter of the tubes.  
 $d_e$  = external diameter.

The efficiency of flash tubes depends on several factors, and this dependence has been investigated by a number of workers.

### 2.3.1. APPLIED FIELD.

To cause a discharge the applied field must exceed the breakdown potential of the gas. The variation of efficiency with field has been investigated by Conversi and Gozzini (5), by Gardener et al., (17), by Coxell and Wolfendale (18) and others. Conversi and Gozzini found no variation in efficiency for fields between 5 and 10 KV/cm. The other workers found an increase in efficiency with increasing field up to values of a few KV/cm when a plateau was reached. Ideally the maximum internal efficiency would be 100%, but Gardener et al. and Coxell and Wolfendale found values of 75% and 95% for fields above 9KV/cm and 6 KV/cm respectively. (Figure 2.1.)

EFFICIENCY VERSUS APPLIED FIELD

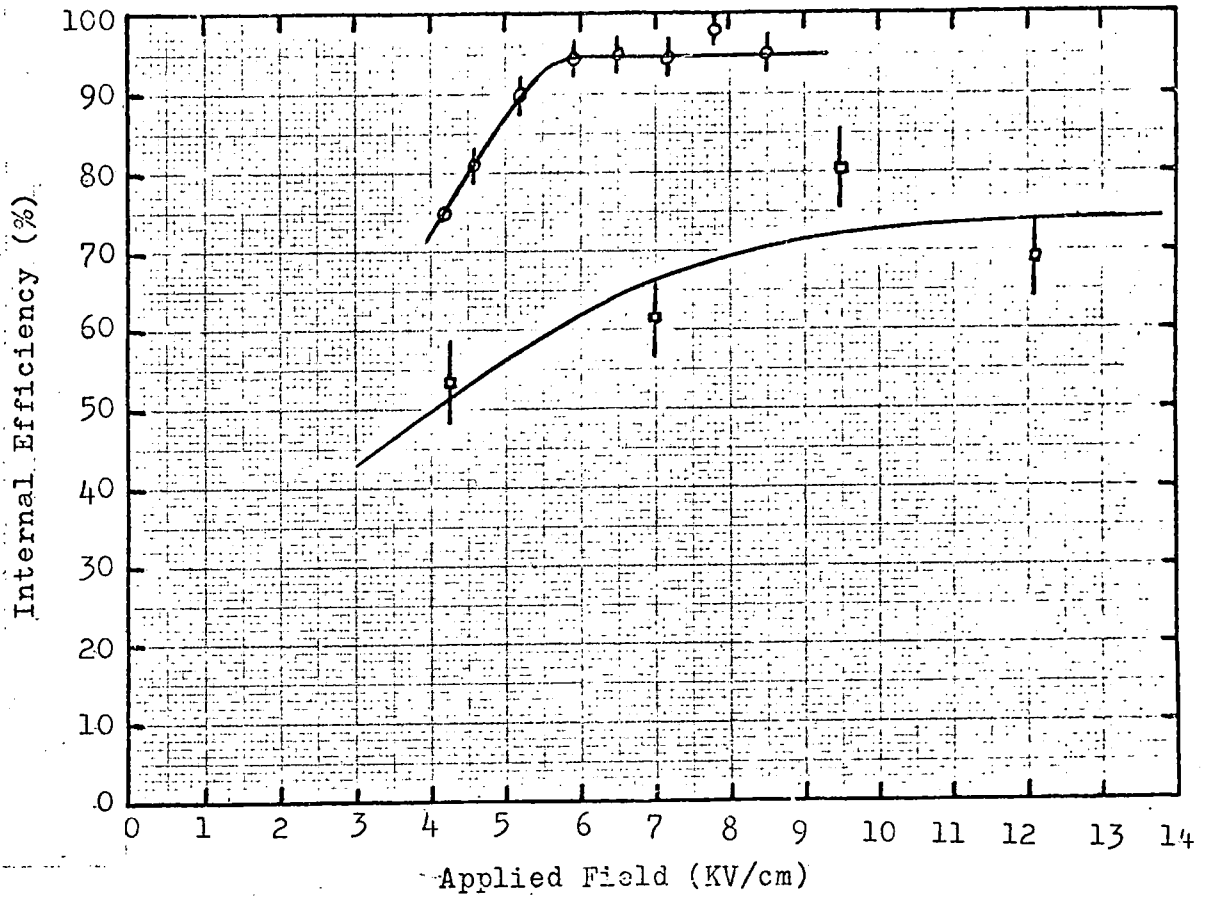

□ Gardener et al.  
○ Coxell and Wolfendale

figure 2.1

The best condition for operation is obviously in the plateau region if high efficiency is required.

### 2.3.2. RISE TIME.

The rise time of the high voltage pulse affects the efficiency of the flash tubes. If the pulse rises slowly to breakdown value some of the electrons will be swept out of the tube without gaining enough energy to initiate a discharge.

Coxell and Wolfendale (18) report a fall of efficiency from 95% to 65% for an increase in rise time from 0.3 to 1.7 micro secs. (figure 2.2.)

### 2.3.3. NATURE OF THE GAS.

Conversi and his co-workers used flash tubes containing pure neon, and neon with 2% argon, and most other workers have used neon with varying amounts of other gases present, although any of the rare gases or mixtures of them would be effective. The choice of neon is due mainly to its low breakdown potential. This can be made even lower by the addition of a small amount of helium or argon when the Penning effect comes into operation. Helium also has a low breakdown potential, but is more expensive than neon.

### 2.3.4. PURITY OF THE GAS.

Commercial neon containing 2% helium is generally used in flash tubes but a mixture of 70% neon and 30% helium can be employed, and is cheaper than the former mixture.

Water and oxygen molecules have a high affinity for free electrons (19) and if they are present in any considerable concentration a reduction in the efficiency of the tubes is inevitable. Some workers have added a small amount of alcohol to the gas (20). This has the same effect as water or oxygen, and tends to reduce the rate of spurious flashing (21). However tubes with alcohol in them have a finite life time because the alcohol molecules are gradually broken down.

EFFICIENCY VERSUS RISE TIME

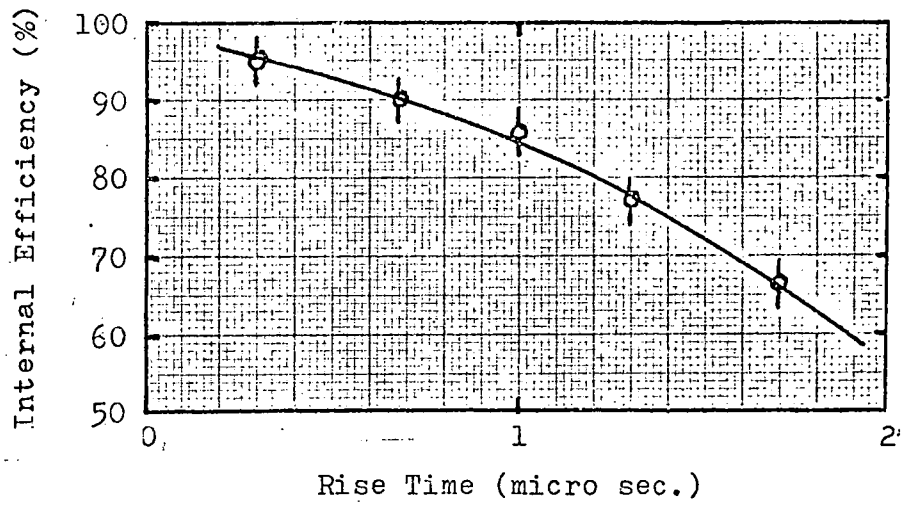

Coxell and Wolfendale.

figure 2.2

EFFICIENCY VERSUS DELAY

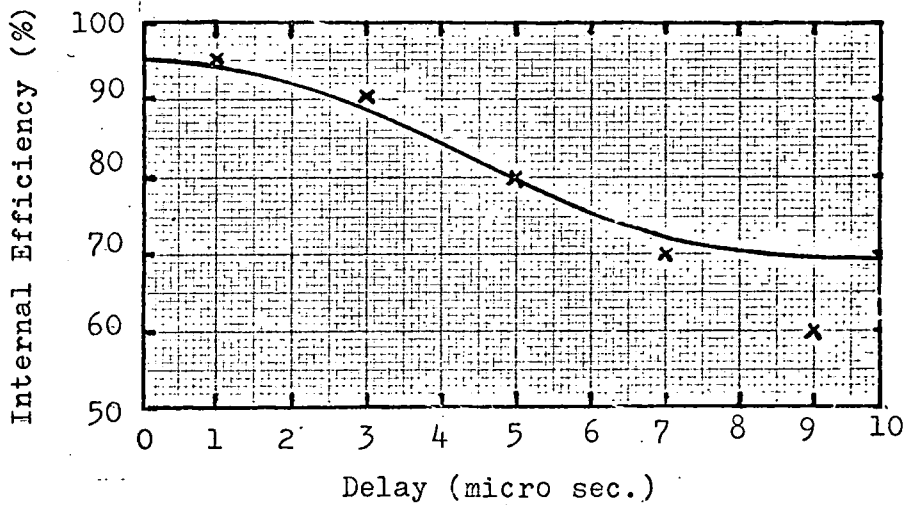

Conversi et al.

x Experiment — Theory

figure 2.3

### 2.3.5 PRESSURE OF THE GAS.

Since the primary ionisation is proportional to the number of gas molecules in the path of the ionising particle, the efficiency of the flash tubes increases with gas pressure. Thus, the low efficiency of small diameter tubes can be brought up to a reasonable value by using a high pressure of neon. Pressures of 30cm Hg up to a few atmospheres have been employed.

### 2.3.6. DELAY.

The electrons liberated by an ionising particle will be slowly removed from the gas by a number of processes, and therefore the efficiency of the flash tubes will decrease with increasing time delay between the traversal of the array by a particle and the application of the high voltage pulse.

Conversi et al. (16) gave a simple theory for the variation of efficiency with delay. Assuming that loss of electrons by recombination is negligible, and that the main process involved is diffusion to the walls of the tube where the electrons have a high probability of capture, it is shown that, provided no electric fields are present, the number of electrons remaining in the tube after time  $t$  is given approximately by:-

$$n(t) = n_0 E(d / 2Dt)$$

where  $n(t)$  = number of electrons at time  $t$ .  
 $n_0$  = initial number of electrons.  
 $E$  = error integral function.  
 = dimensionless shape factor, 0.4 for the tubes considered by these workers.  
 $d$  = diameter of tube.  
 $D$  = diffusion coefficient.  
 $t$  = delay time.

In this paper Conversi and his co-workers plot their experimental results, using an applied field of 8 KV/cm, and compare them with the curve given by the above equation. (figure 2.3). The agreement is good considering the simplicity of the theory.

A more detailed and accurate theory of flash tube efficiency as a function of delay has been worked out by Lloyd (22) in 1960.



Lloyd considers a three dimensional diffusion equation and solves it in cylindrical coordinates for the boundary conditions of a flash tube. Besides the primary ionisation he considers electrons produced by the decay of metastable atoms and their subsequent diffusion, electrons produced from metastables during the high voltage pulse, and electrons knocked out of the walls of the tube into the gas by the primary particle. He concludes that electrons produced by other mechanisms are few compared with the primary ionisation. He also assumes that the electrons have thermal energy, but points out that for short time delays of less than 1 micro sec. this is not true and the theory is only an approximation.

A number of workers have investigated the variation of efficiency with delay experimentally. The results of Gardener et al. (17) and Coxell and Wolfendale (18) are given in figure 2.4. The experimental curves have been made to fit Lloyd's theory by adjusting the value of a parameter F, the probability of one electron initiating a discharge, thus providing an empirical relationship between efficiency and delay. (figure 2.5.)

The efficiency of the flash tubes is thus given by:-

$$\eta = 1 - \text{EXP}(-Q \cdot F)$$

where  $\eta$  = efficiency  
 $Q$  = number of electrons present  
 $F$  = probability of one electron initiating a discharge.

#### 2.4. ANOMALOUS FLASH TUBE RESULTS.

Recently some experimental results have been obtained with flash tubes which cannot be explained by Lloyd's diffusion theory.

##### 2.4.1. EFFICIENCY VERSUS DELAY

The experimental curves of efficiency against delay can be made to fit the theory by adjusting the value of F, but while this provides an empirical relationship it does not allow the variation to be predicted with any degree of accuracy for a given set of conditions. Different workers have found different values of F and no satisfactory explanation has been given of way this difference occurs.

EFFICIENCY VERSUS DELAY

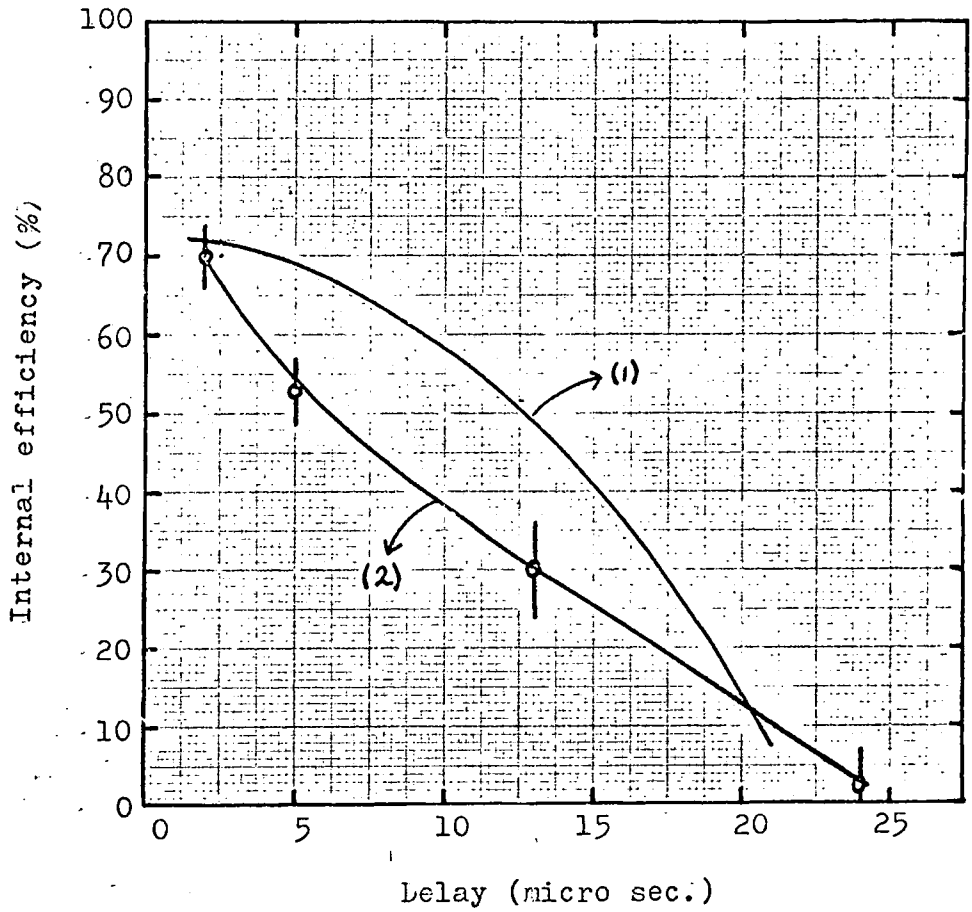

(1) Gardener et al.

(2) Coxell and Wolfendale

figure 2.4

EFFICIENCY VERSUS DELAY

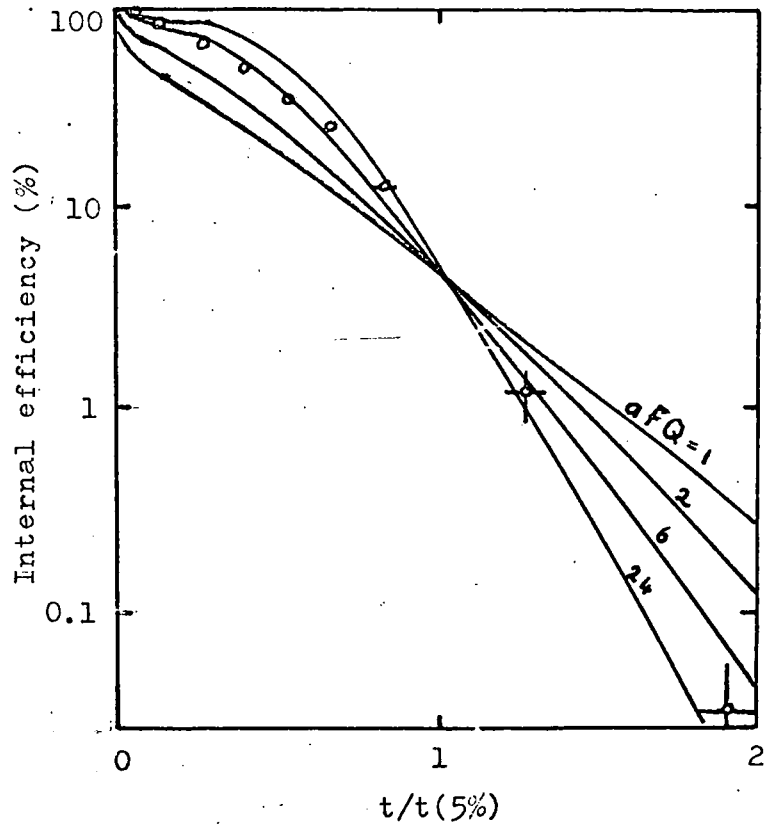

— Lloyd. Theory.

⊗ Coxell and Wolfendale. Experiment.

$a$  = Radius of flash tube.

$F$  = Probability of a single electron  
initiating a flash.

$Q$  = Initial ionisation.

figure 2.5

#### 2.4.2. EFFICIENCY VERSUS APPLIED FIELD

In 1968 Pickersgill (23) investigated the effect of applied field on flash tube efficiency. He found that the efficiency increased with field up to a certain value, as other workers had observed, but on further increasing the field the efficiency started to fall off.

#### 2.4.3. EFFICIENCY VERSUS REPETITION RATE.

Some workers (24) have found that the efficiency of flash tubes is decreased if the repetition rate is increased. Perhaps the best illustration of this is given by figure 2.6. This shows two events taken within a minute of each other on the Durham Quark experiment of Ashton et al. (12). This experiment is based on the assumption that a quark, having charge  $\frac{1}{3}$  or  $\frac{2}{3} e$  will produce less ionisation in the flash tube than a muon with unit charge. For highly efficient tubes this would make little difference in efficiency, so a delay of about 40 micro secs. is introduced to allow some of the electrons to diffuse away. The efficiency of the tube is thus reduced, and made more sensitive to differences in primary ionisation.

The first picture shows the tracks of four particles crossing the array. The second, taken less than a minute later, shows a shower passing through the instrument causing almost every tube to flash except those which had flashed in the previous event. This clearly shows that once a tube has flashed it may be inefficient for some time, longer than a minute, afterwards.

#### 2.4.4. SPURIOUS FLASHING.

It has been found that flash tubes will sometimes flash when pulsed even if no particle has passed through them. (17, 24, 25). Some tubes appear to be worse than others, though no correlation between spurious flashing and any other property of the flash tubes has been found, and the reason for the phenomenon is not known.

DURHAM QUARK EXPERIMENT

(Ashton et al.)

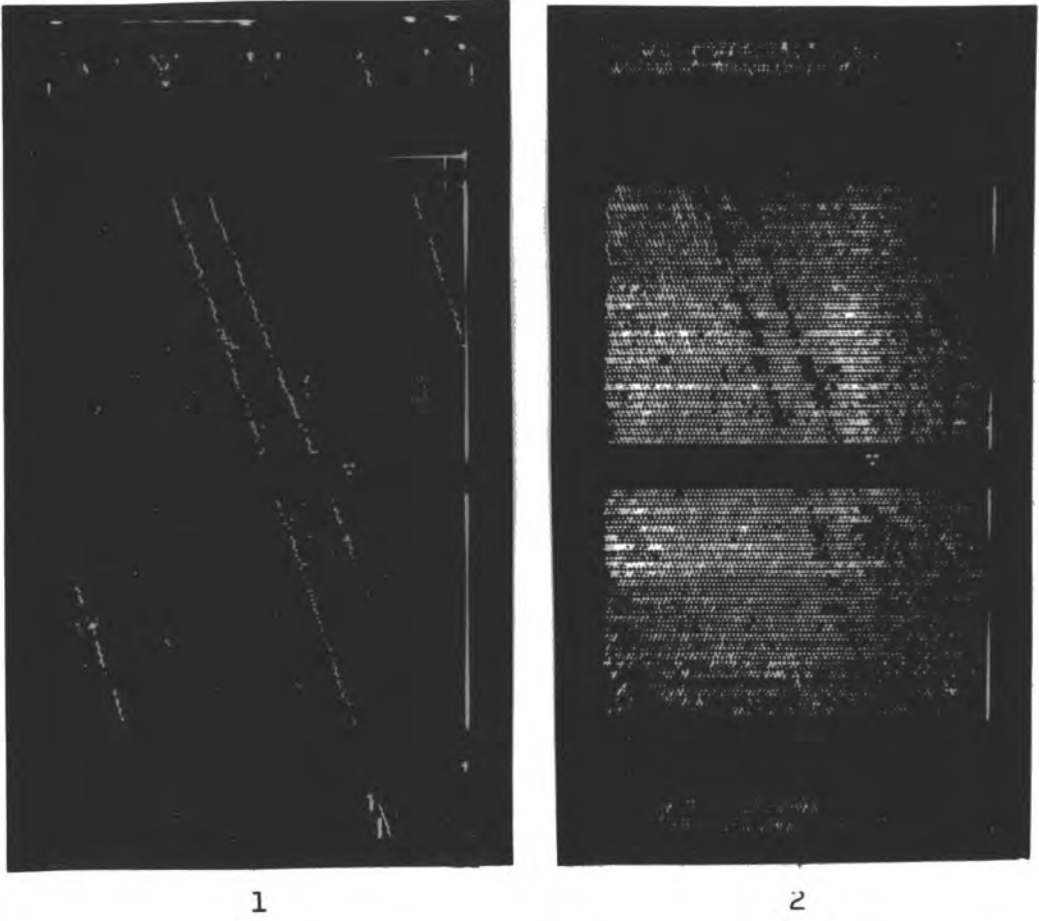

figure 2.6

2.4.5. AFTER FLASHING.

Another phenomenon which may be disadvantageous if the tubes are to be pulsed at high repetition rates is after flashing, although this has been made use of as a method for storing information in the flash tubes for several m.sec. Conversi et al. observed that if a tube flashed due to the passage of a particle, and a second pulse was applied after a time  $t < T$ , the tube reignited. (16) They defined  $T$  as the recovery time of the tubes, and found its value to be about 0.1 sec.

The process of after flashing is not understood; according to diffusion theory the electrons should have been removed from the gas in a time much less than 0.1 sec.

2.5. POSSIBLE EXPLANATIONS.

Some attempts have been made to explain these results. Pickersgill (25) suggested that polarization of the glass takes place when a discharge occurs, producing an electric field in the tube which "backs off" the pulsed field next time it is applied, thus reducing the efficiency.

It has been suggested by Hampson (26) that the discharge deposits electrons on the glass surface and these leak away very slowly because of the high surface resistance of the glass. These electrons set up a "clearing field" in the flash tube which sweeps out some of the electrons before the high voltage pulse is applied. Or alternatively, that the glass is polarized as suggested by Pickersgill and that this itself provides a clearing field. Obviously the higher the repetition rate, the more the clearing field is built up.

Various pulse shapes have been used to try to overcome the clearing field effect and allow flash tube arrays to be operated efficiently at high repetition rates. Pickersgill concluded that a square pulse gives a higher efficiency than an R.C. pulse, and put this down to the fact that the R.C. pulse, having a long tail, has a larger polarizing effect than the square pulse with no tail.

Crouch et al. (27) tried various pulse shapes. The results were inconclusive, but it appeared that a bipolar ringing pulse did reduce the clearing field effect. These workers also found some evidence that an increase in atmospheric humidity increases the efficiency of the flash tubes.

## 2.6. CONCLUSION.

The work which has been done with neon flash tubes has shown that they are useful in providing relatively cheap, large area detectors, of good resolution. Provided the operating conditions are chosen correctly they have high efficiency, and it has been shown that the accuracy of track location is comparable to that in a cloud chamber.

However, considering the large discrepancies between the results of various workers in measuring the variation of efficiency with repetition rate and with delay, and the lack of any theory which is able to predict this variation satisfactorily, it is evident that there is a need for further research into the existence and nature of the clearing fields which are thought to be responsible for these discrepancies, and into methods of preventing their building up.

## CHAPTER 3.

### EXPERIMENTAL INVESTIGATION OF CLEARING FIELDS.

#### 3.1. INTRODUCTION.

The previous chapter contains a summary of the work which has been done up to the present time on the characteristics of neon flash tubes, and it has been shown that some of the results obtained cannot be explained by considering a simple diffusion process for removing electrons from the tube. The results can be accounted for, however, in terms of clearing fields which sweep electrons out of the tube before the application of the high voltage pulse, thus reducing the efficiency at long delays. This chapter describes experiments designed to investigate the existence of these clearing fields, to determine their nature and their cause, and to find methods of eliminating them.

The experiments include measurements of the layer efficiency of flash tube arrays in very carefully controlled conditions, and of some of the properties of individual flash tubes.

#### 3.2. THE FLASH TUBE PULSING SYSTEM.

A block diagram of the apparatus used in the measurement of efficiency is shown in figure 3.1. An array of flash tubes was triggered on cosmic rays by means of a small scintillator telescope. The pulse obtained on coincidence between the two counters was used to trigger two spark gaps, one immediately, and the other after a variable delay. The minimum delay between the passage of a particle through the detector and the start of the high voltage pulse was 400 n.sec.



FLASH TUBE PULSING SYSTEM

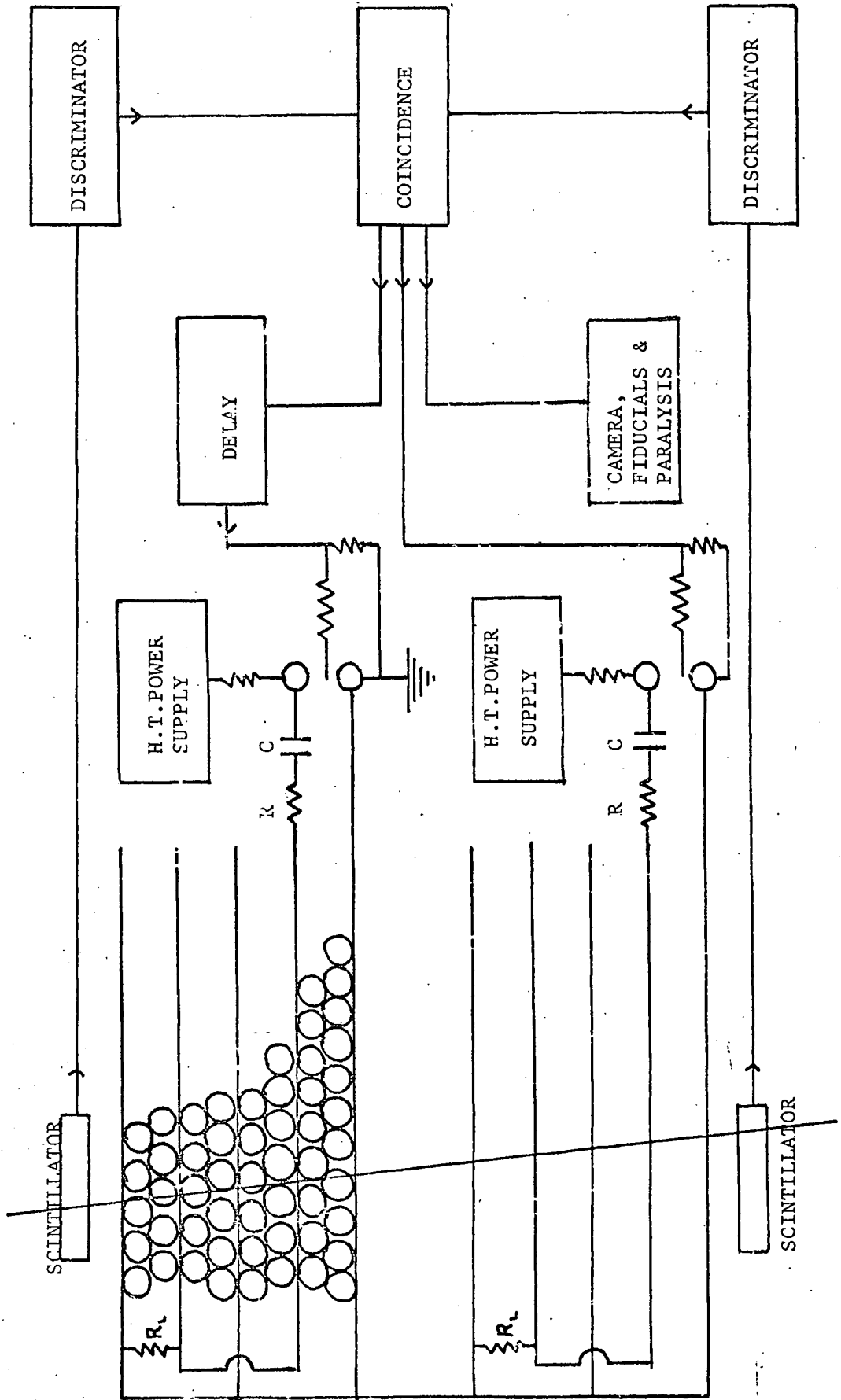

figure 3.1

The high voltage pulse applied to the array had an RC decay constant depending on C, the charging capacitor, and  $R_1$  the load resistor. The RC constant was varied by changing the value of  $R_1$  and RC constants of 0.4 to 200 micro sec. were used. The two spark gaps were supplied by different power units to allow independent variation of pulse height; and both positive and negative pulses up to 7 KV/cm were employed. Rise times of 40 to 500 n.sec. (10% to 90%) were obtained by varying the value of the resistor R in series with the high voltage electrode.

Figure 3.2 (a) shows a typical high voltage pulse. (b) shows the rising edge of a pulse obtained with  $R = 0$ , and is seen to ring. With  $R = 47$  ohms, the rise time is not greatly increased, (c) and the ringing is damped out. This is essential if pulse heights for different rise times are to be compared, since for a ringing pulse it is uncertain whether the mean height or the peak height should be considered.

Tracks in the array could be photographed, and the coincidence signal was also used to trigger the camera winding mechanism, the fiducial lights and a paralysis unit by means of which the event rate could be varied.

Two basic arrays of flash tubes were used. One consisted of two banks of 8 layers of tubes, 40 tubes wide. One bank was pulsed in conditions which gave highly efficient tracks, and was used to define the path of the particle, and the other was operated with varying high voltage pulse parameters.

The second array consisted of 96 layers of 10 tubes arranged in 3 sections which could be pulsed independently. This array was used when very slow repetition rates were required, so that good statistics could be obtained in a reasonable time.

Comparison showed that measurements of efficiency for the same high voltage pulse parameters on the two arrays agreed within the statistical error of about 1%. Unless otherwise shown, all experimental efficiencies had errors less than or equal to this value. A typical cosmic ray track through part of the second array is shown in the frontispiece.

The flash tubes used were made of soda glass, 100 cm. long, 1.6 cm. internal diameter, 1.8 cm. external diameter, and were filled

TYPICAL PULSES

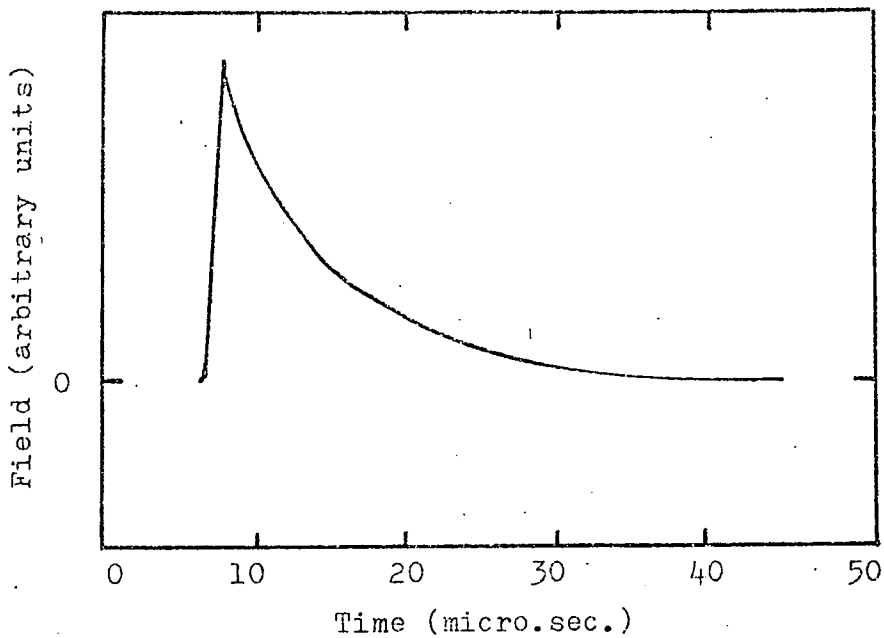

(a)

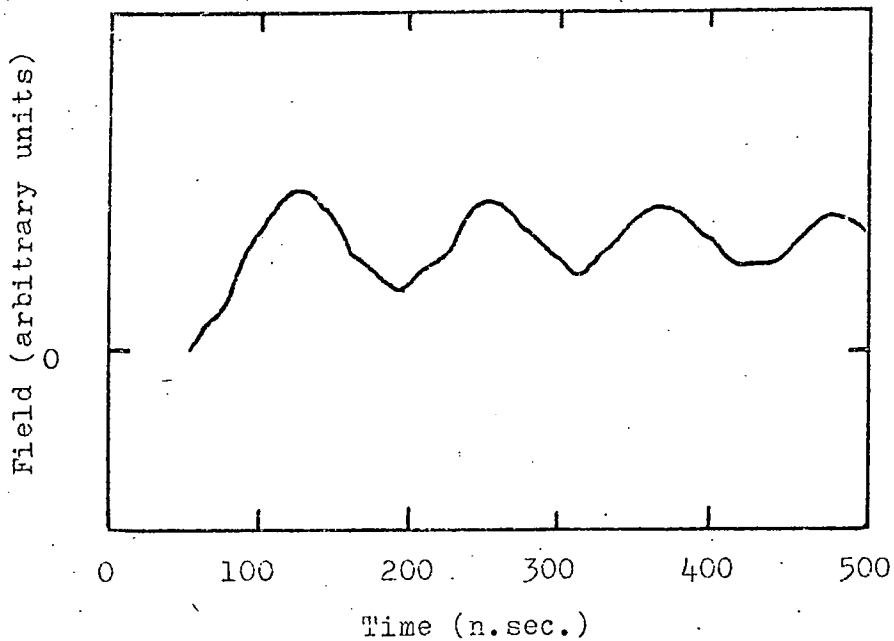

(b)

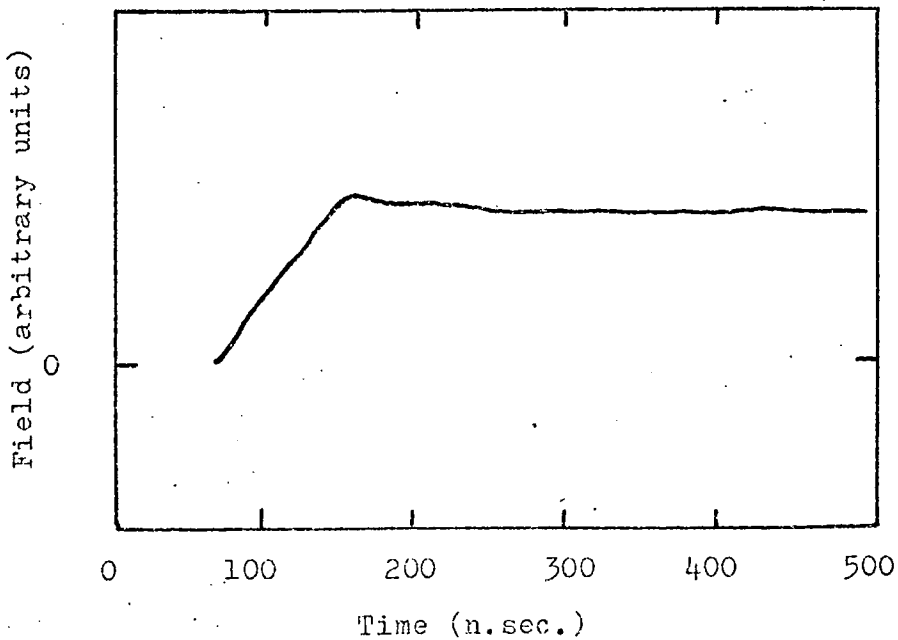

(c)

figure 3.2

with a 98% neon 2% helium mixture at a pressure of 60 cm.Hg. Unless otherwise stated, these tubes were used in all the experiments.

The efficiency of flash tubes depends on the magnitude of the high voltage pulse applied to them, in general increasing with increasing field until a maximum value is reached. A typical plot of efficiency as a function of applied field is shown in figure 3.3, and unless otherwise stated the tubes were operated in the plateau region.

### 3.3. EVIDENCE FOR CLEARING FIELDS.

Using the first of the flash tube arrays described in the previous section, the layer efficiency was measured as a function of delay. The event rate was 1 / 5 sec., which corresponds to a rate of about 1 flash/minute/ tube. The efficiency against delay curves for high voltage pulses with different decay constants are shown in figure 3.4, and it can be seen that the efficiency falls off with increasing delay much more rapidly for longer high voltage pulses. If one assumes that the efficiency of a tube depends on the number of electrons present in it when the high voltage pulse is applied, and that this is governed mainly by diffusion of electrons to the walls of the tube where they are captured, as described by Lloyd (22), then the efficiency for a given delay should be independent of the duration of the applied field. However, if an electric field is present, electrons will be swept to the walls more rapidly than by a simple diffusion process, and the efficiency will fall off faster with increasing delay. In the light of figure 3.4, one must postulate a mechanism which depends on the duration of the applied field.

The preceding experiment was repeated using the tall flash tube array and a much slower event rate of about 1/5 minutes, or 1 flash / 30 minutes / tube. The results are shown in figure 3.5, and it can be seen that the efficiency is now independent of high voltage pulse length, and agrees reasonably well with Lloyd's theoretical curve with  $F$ , the probability of one electron initiating a discharge, equal to 0.3, and an ionisation,  $Q$ , of 33.6 ion pairs / cm at 1 atmosphere pressure, given by Eyeions (31). This indicates that in this case, electrons are removed chiefly by a diffusion process. The factors influencing the value of  $F$  will be discussed in a later chapter.

These experiments show that the clearing field effect is apparent only for high repetition rates, and that it increases with increasing high voltage pulse length.

EFFICIENCY VERSUS APPLIED FIELD

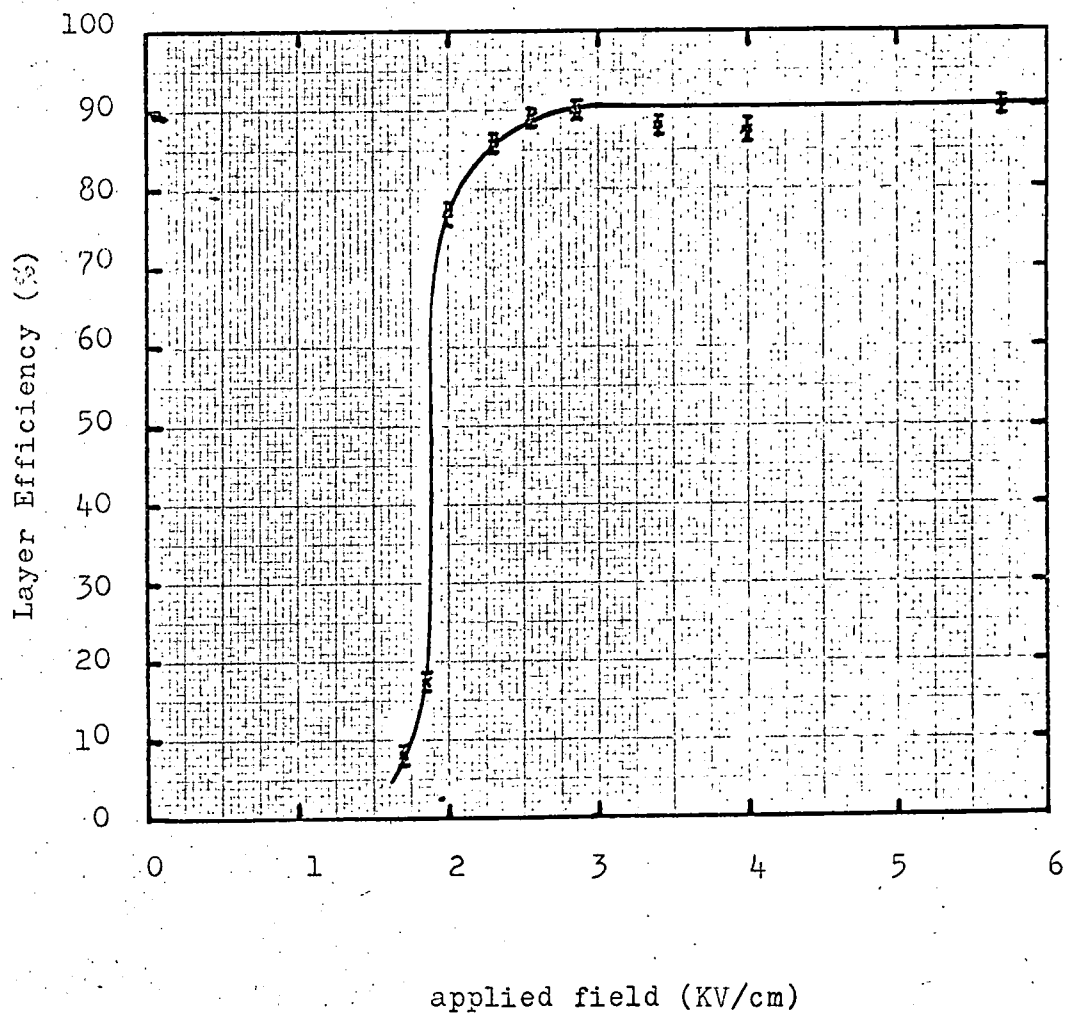

applied field (KV/cm)

R.C. = 4 micro sec.

rise time = 40n. sec.

delay = 400n. sec.

repetition rate = 1/60 sec./tube

figure 3.3

EFFICIENCY VERSUS DELAY  
FOR FAST RATE

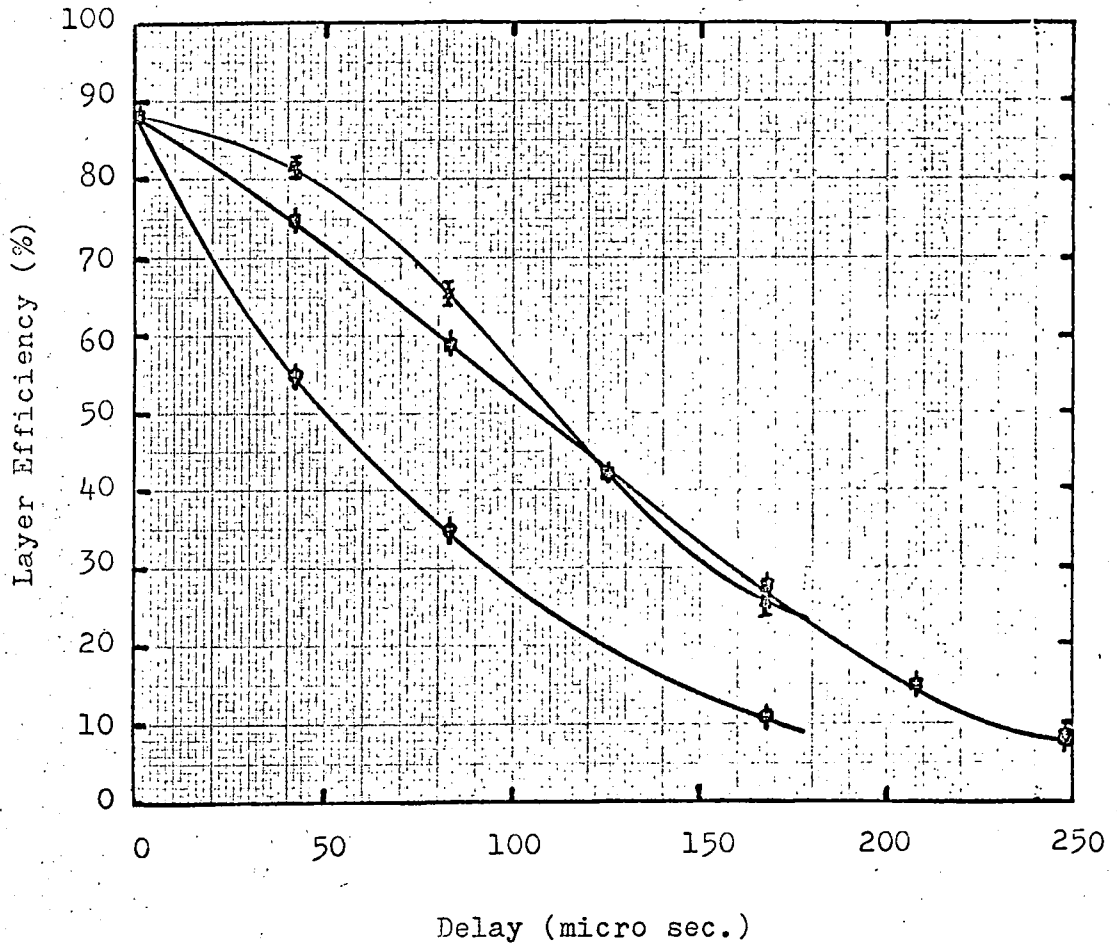

Pulse lengths

$\bar{\times}$  = 0.4 micro sec. R.C.

$\square$  = 4.0 micro sec. R.C.

$\phi$  = 40.0 micro sec. R.C.

Rate = 1/minute/flash tube

figure 3.4

EFFICIENCY AS A FUNCTION OF DELAY

FOR SLOW REPETITION RATE

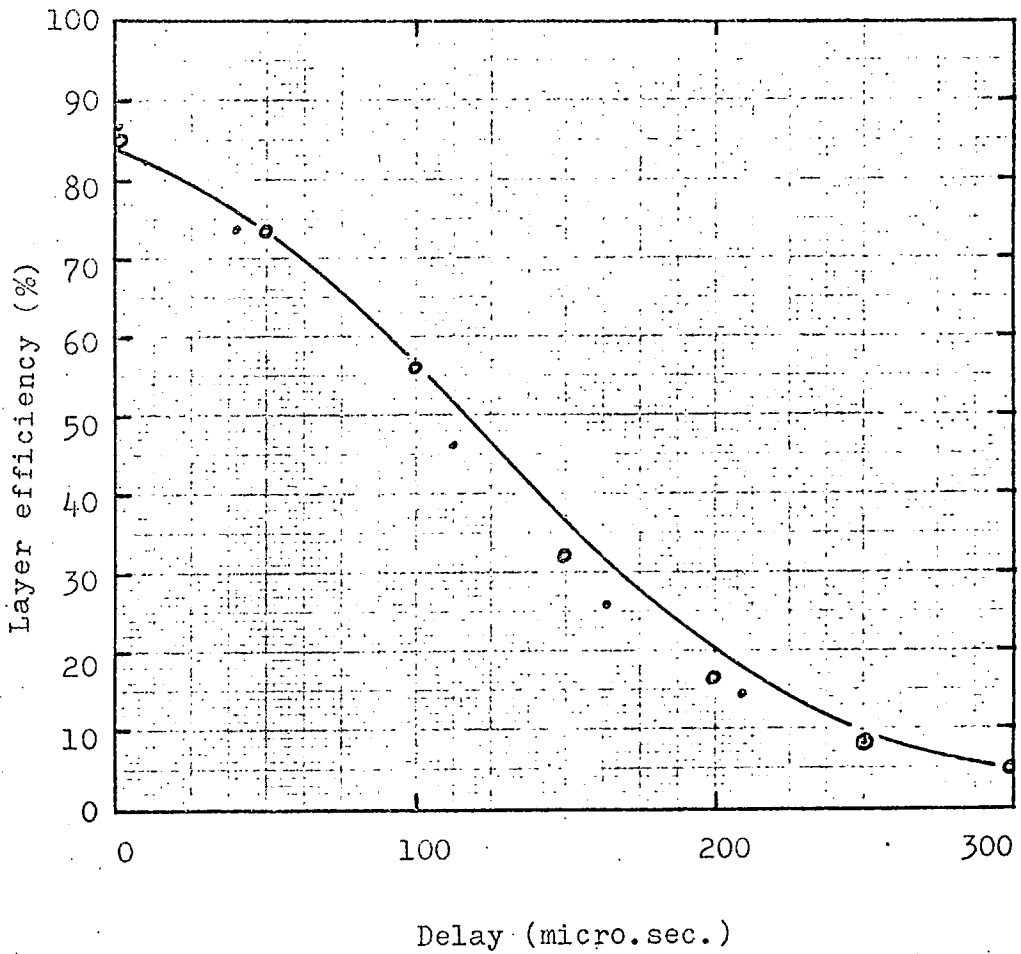

- 26.8 micro.sec.R.C. high voltage pulse
- 0.4 micro.sec.R.C. high voltage pulse
- Theoretical curve for  $FQ = 10$

figure 3.5

### 3.4. EXTERNAL CLEARING FIELDS.

An external clearing field of 8.5 V/cm was applied to the flash tube array to see if the clearing field effect described in the previous section could be simulated in this way. For a high voltage pulse of 4 KV/cm, a decay constant of 80 micro sec. and a rise time of 70 n.sec., the efficiency at 50 micro sec. delay was reduced from 73% for no applied clearing field, to 67.4% for a clearing field of the same sign as the high voltage field, and 67.1% for a clearing field of the opposite polarity. These are identical within the statistical error of  $\pm 1.6\%$ .

However, if one assumes a drift velocity of about  $1.5 \times 10^5$  cm/sec. for electrons in neon at 60 cm.Hg pressure in a field of 8.5 V/cm., given by Pack and Phelps (28), it will be shown in chapter 5 that all the electrons should have been removed from the gas in 50 micro sec., and the efficiency reduced to zero.

The discrepancy could be due either to an incorrect assumption about the drift velocity or an incorrect value of the effective clearing field. This will be discussed in chapter 6.

### 3.5. TWO CLEARING FIELD EFFECTS.

During the initial measurements of efficiency as a function of delay, certain points were repeated, and in some cases were found to disagree significantly with the original values under conditions, including repetition rate, which were apparently identical. When measurements were made at slow repetition rates, of about 1/5 minutes, they were always reproducible. It was inferred that a run might somehow be influenced by previous runs if these were such that clearing fields were built up.

Accordingly, the apparatus was run at high efficiency and a high repetition rate for several days, and during this time the efficiency at 50 micro sec. delay and a slow repetition rate was monitored. This was found to decrease as the high efficiency run progressed, although no clearing field effect was observed in a similar run which was not preceded by a high efficiency run. On terminating the high efficiency run, the efficiency at 50 micro sec. delay rose slowly, over a few days, to its original value. (figure 3.6) Over a single  $\frac{3}{4}$  hour run at a high repetition rate, equilibrium seems to be reached in a matter of a few seconds. Figure 3.7 shows the sum, over 50 such runs at 50 micro sec.



CLEARING FIELD EFFECT DURING AND AFTER HIGH EFFICIENCY RUN

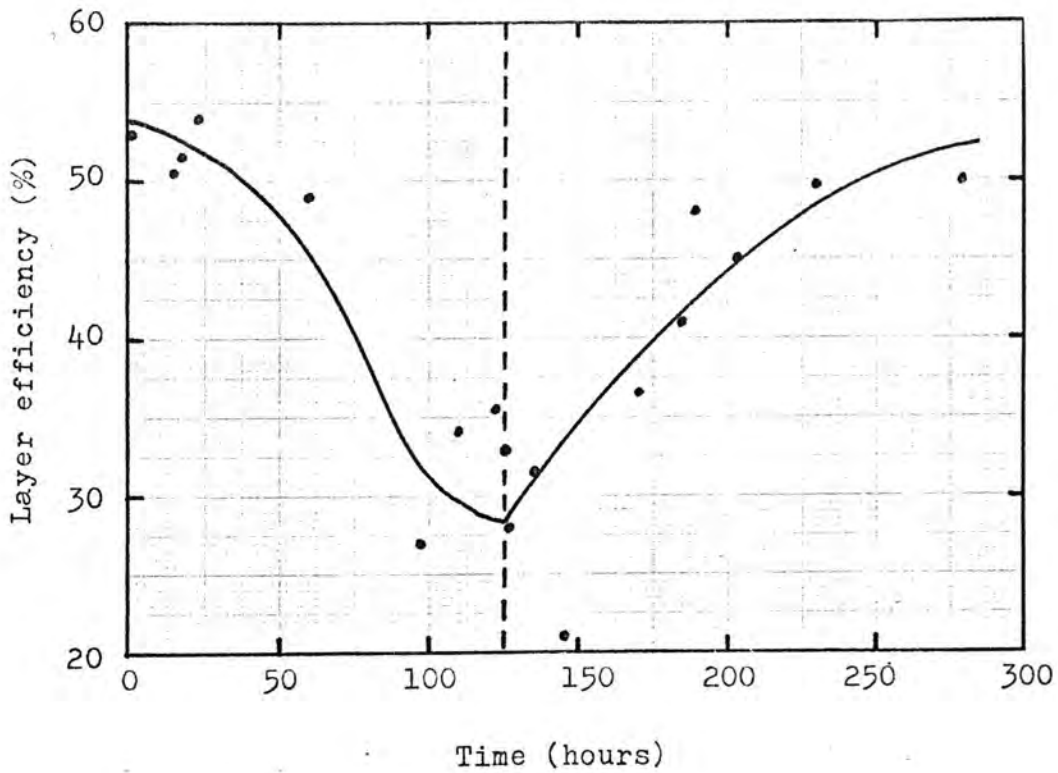

--- Termination of high efficiency run

figure 3.6

CLEARING FIELD EFFECT DURING A RUN

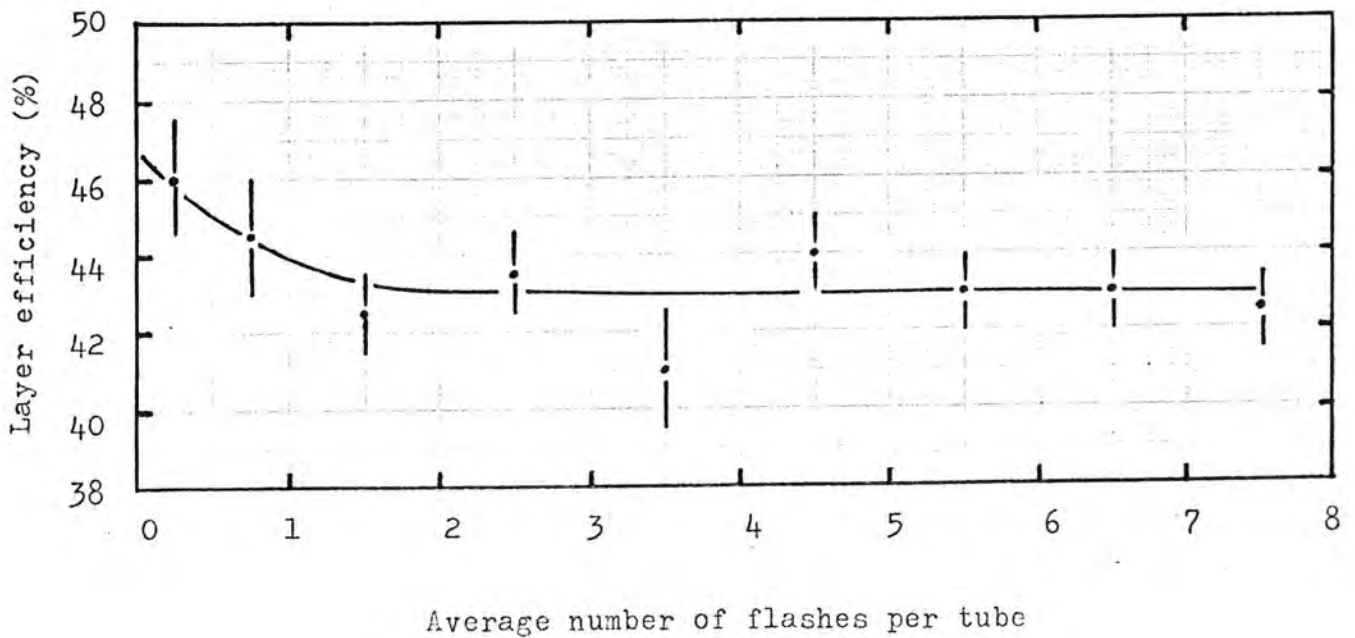

figure 3.7

delay, of the efficiency as a function of average number of flashes/tube. From the two experiments, two clearing field effects are indicated, one which takes effect and decays in a matter of seconds, and a long term effect with time constant of the order of days.

3.6. THE SHORT TERM CLEARING FIELD EFFECT.

Measurements of the short term clearing field effect were made, with several hours between runs to ensure that the long term clearing fields had not chance to build up. Figure 3.8 shows the variation of efficiency with interval between events, using a 50 micro sec. delay, and a high voltage pulse of 2.8 KV/cm and decay constant of 26.8 micro, sec. It can be seen that an interval of about 12 minutes between successive discharges in a tube is required for the clearing field to decay below a detectable level.

3.7 THE NATURE AND CAUSE OF CLEARING FIELDS.

That the short term clearing field effect is due to the discharge and not simply to the application of the high voltage pulse is clearly shown by photographs obtained at high repetition rates showing two successive events, the first being the track of a single muon, and the second being a shower which causes almost every tube to flash except those which flashed in the first event. One such photograph is shown in figure 3.9. The repetition rate was about 1 / minute / tube. A high voltage pulse of 4 KV/cm and RC constant of 15 micro sec. was used.

In order to investigate the dependence of the clearing field effect on high voltage pulse length, the efficiency of flash tubes as a function of RC decay constant of the high voltage pulse was measured for a repetition rate of about 1 / minute / tube. The result, given in figure 3.10, shows that for a 50 micro sec. delay and a 4 KV/cm applied field, the clearing field effect increases with increasing high voltage pulse length until a constant value is reached at an RC constant of about 40 micro sec.

Experiment shows that the clearing field effect does not depend on the magnitude of the applied field. Figure 3.3 shows the variation of efficiency with applied field for a fast repetition rate, i.e. in circumstances where clearing fields are built up. The efficiency reaches a constant value above a given field, and does not decrease with increasing field, showing that the clearing field effect is independent of applied pulse height. The same type of curve, i.e. with a plateau above a certain value of field, was obtained for delays of zero to 300.

EFFICIENCY AS A FUNCTION OF INTERVAL BETWEEN FLASHES

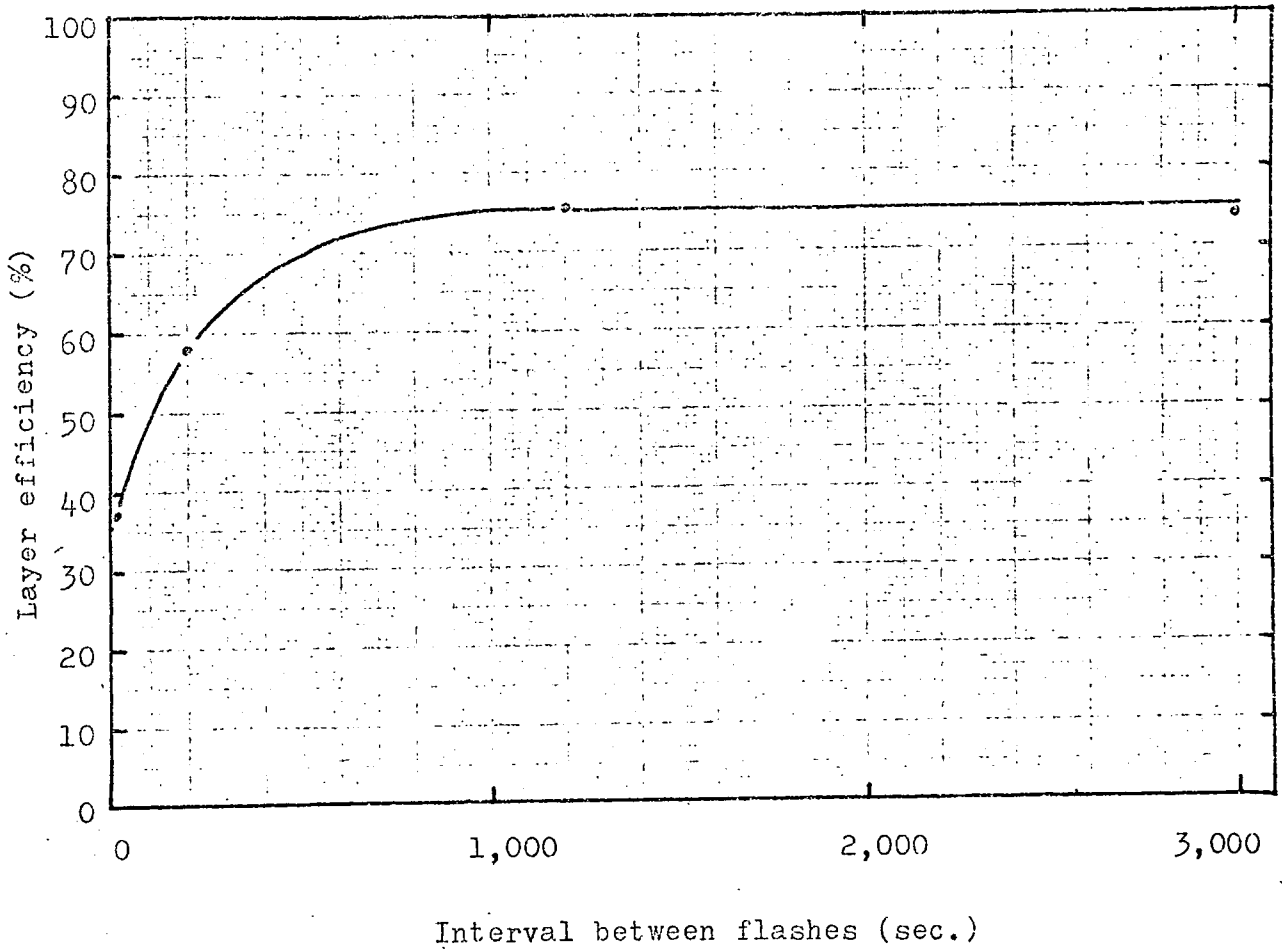

figure 3.8

SUCCESSIVE EVENTS AT HIGH REPETITION RATE

SHOWING THE CLEARING FIELD EFFECT



(a)



(b)

figure 3.9

EFFICIENCY VERSUS PULSE LENGTH  
FOR DIFFERENT RATES

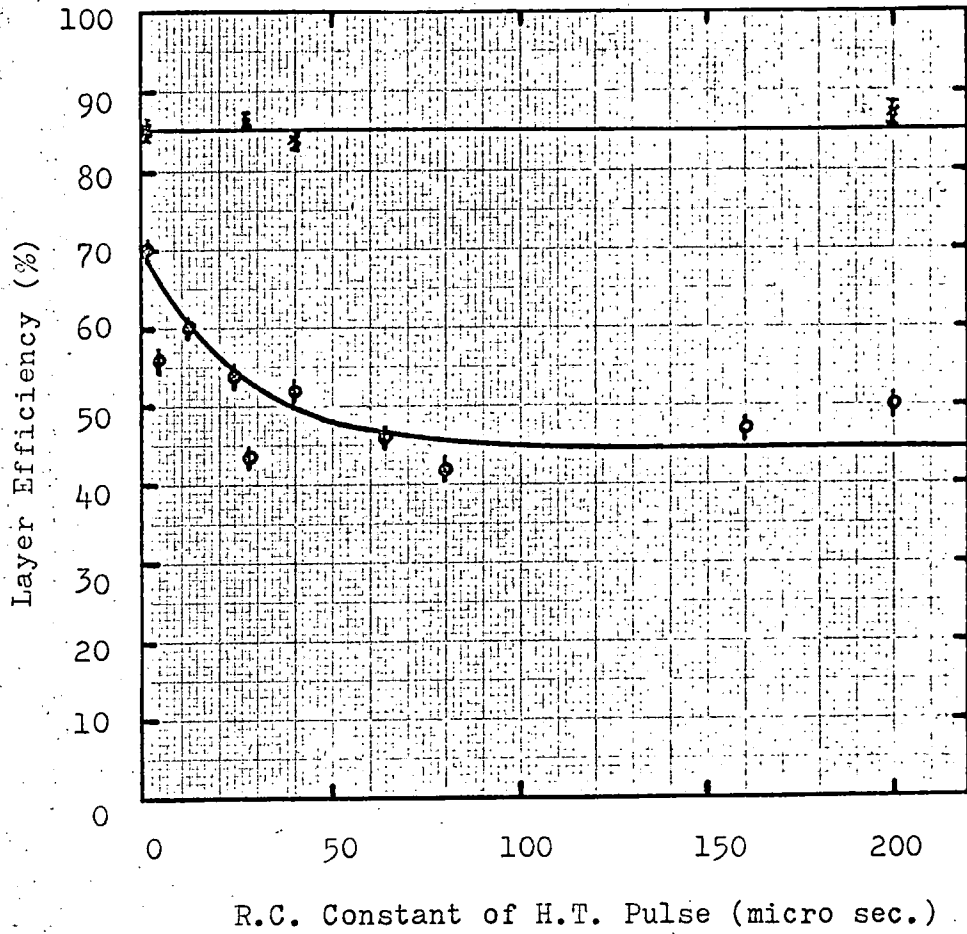

Repetition Rate

- ⊕ = 1/minute/flash tube
- ⊗ = 1/30 minutes/flash tube

figure 3.10

micro. sec, and for high voltage pulse lengths of 0.4 to 40 micro. sec. RC constant.

Since the clearing field effect occurs only when a tube has discharged, there seem to be two possible explanations. One is that the field is due to charge deposited on the glass during the discharge, which leaks away very slowly, and the other is that the glass is polarised by the increased field which appears across it when the gas breaks down and becomes conducting.

The variation of efficiency with applied pulse length indicates the former process since a maximum effect would be expected when all the positive ions in the discharge were deposited on the glass during the high voltage pulse, and it is estimated from drift velocities given by Von Engel (33) that this would occur with a pulse of 4KV/cm and a decay constant of about 80 micro sec.

3.8. DECAY OF THE CLEARING FIELDS

If the clearing fields are due to charge deposited on the walls of of the flash tube during the high voltage pulse, they will decay by conduction of electrons over the glass surface with a time constant which depends on the resistivity of the glass and the capacitance of the flash tube.

The resistivity of the glass of which flash tubes are manufactured was measured in the following way. A pair of aluminium foil electrodes were wrapped round a flash tube, one at each end; one electrode was connected to a 2 KV power supply and the other to one terminal of an electrostatic voltmeter, the other terminal of which was earthed. The high voltage supply was switched on, and the potential at the other end of the flash tube was measured by means of the electrostatic voltmeter, as a function of time. The difference between the measured potential and the final potential (i.e. the potential of the high voltage supply) was plotted on a logarithmic scale against time, and hence the time constant of the charging process was obtained. Assuming this to be an RC constant, and knowing the capacitance of the voltmeter, the resistance of the tube was found, and from its geometry, the resistivity was calculated, assuming the conduction to be a surface phenomenon.

The resistivity was found to vary considerably with surface conditions, and with temperature and humidity. However, measurements made on lengths of glass in a dessicator, or in an evacuated or neon

filled system were fairly constant, giving a value of  $5 \times 10^{13}$  ohms/square. The measurement was repeated using a potential of about 10 volts, and the same value of resistivity was obtained, showing that Ohm's law is obeyed. The same value was also obtained if charge was sprayed onto the glass from a pointed electrode, instead of using a foil electrode in direct contact with the glass.

The low value of resistivity of about  $10^8$  ohms/square obtained in free air is thought to be due to water deposited on the glass from the atmosphere. Since flash tubes are evacuated before filling, and often heated, which will remove some of the water, it seems reasonable to take the high value of resistivity as the one appropriate for the inside of a flash tube.

The volume resistivity was measured by placing two electrodes, one inside and one on the outside of a length of glass tube, far from the ends so that the surface resistance was large, and finding the resistance from the charging time constant as before. The volume resistivity was found to be about  $5.3 \times 10^{13}$  ohms cm.

The capacitance of the tubes was measured in the following way. Using an A.C. bridge the capacitance of different numbers of flash tubes between a pair of plane metal electrodes was measured, and hence the capacitance of a single tube and of the electrode system was found. The experiment was repeated for flash tubes broken open and filled with (a) carbon tetrachloride and (b) ethyl alcohol. Assuming that the equivalent circuit is given by figure 3.11, and knowing the dielectric constants of the fillings used, the effective capacitance of the inside of a neon filled flash tube was found to be 4.25 pF.

Thus the calculated RC decay constant for charge on the inside of a flash tube is 2.7 sec.

The magnitude of the clearing fields remaining in the flash tubes after an event will be discussed more fully in chapter 5.

3.9 ARTIFICIAL MEANS OF REMOVING THE CLEARING FIELDS.

In normal circumstances the clearing fields will decay by conduction of electrons over the glass surface. Since the resistivity of glass is high, this process takes place slowly. The efficiency of tubes made of a glass with a lower conductivity was measured at 50 micro sec. delay and a repetition rate of 1/ minute/ tube, using a 4KV/cm pulsed field

FLASH TUBE AND EQUIVALENT CIRCUIT

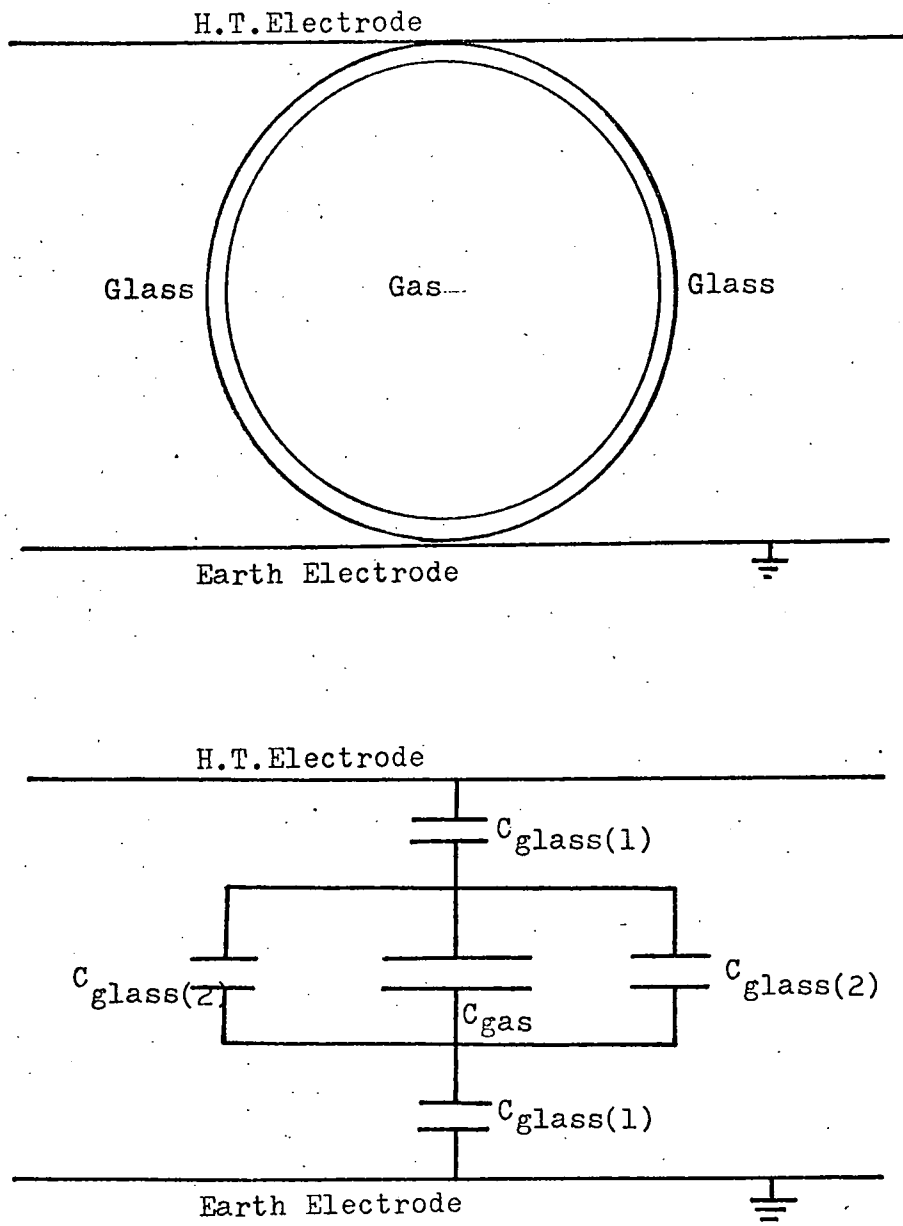

figure 3.11



with a 40 micro sec. decay constant. The value obtained was 31% which is significantly lower than the 51%, shown by normal tubes. Hampson (26) found that the efficiency of Pyrex tubes (with higher resistivity than soda glass) had a lower efficiency at high repetition rates than soda glass tubes. It was therefore decided to investigate increased surface conductivity as a means of reducing the clearing field effect.

### 3.10 STANNIC OXIDE COATED TUBES.

Flash tubes 10 cm long, whose inner surface was coated with stannic oxide to give a surface resistivity of  $10^4$  ohms /square were constructed, but these tubes either did not flash at all, probably because the conducting surface reduced the field across the gas to a value too low to support a discharge, or the rate of spurious flashing was extremely high; approaching 100%.

### 3.11. TUBES WITH HIGH WATER CONTENT

Since the resistance of glass had been found to be markedly dependent on humidity, 4 sets of tubes, A, B, C and D were manufactured containing different amounts of water vapour. Measurement of efficiency as a function of delay for a repetition rate of 1/30 minutes / tube for groups A and B gave the graph shown in figure 3.12 . The efficiency falls off with increasing delay much more rapidly than for ordinary tubes because water molecules have a high affinity for free electrons and thus the number of electrons left in the tube when the high voltage pulse is applied is reduced. The attachment coefficient is given by S.C.Brown (37) as  $4 \times 10^{-4}$  / collision at  $20^\circ$  C. From this value and assuming a collision rate of  $1.3 \times 10^{11}$ /sec, at 1 atmosphere pressure, the amount of water vapour in the two sets of tubes was calculated from the reduction in efficiency. The values obtained were 0.05 mm Hg for group A and 2.5 mm Hg for group B. The contents of group A were subsequently analysed, and a pressure of 0.04 mm Hg measured. It is possible that group B also contained oxygen. The water used in these tubes had been left exposed to the air for some time after distillation, and may therefore contain dissolved oxygen.

When operated at rates up to 1 / 10sec/ tube, group B showed no change in efficiency, i.e. no clearing field effect, although ordinary tubes operated under the same conditions showed a marked clearing field effect. When group A were pulsed at this rate they showed an increase in efficiency, and after a period of a few weeks they showed an efficiency

EFFICIENCY AS A FUNCTION OF DELAY

FOR FLASH TUBES WITH A HIGH WATER CONTENT

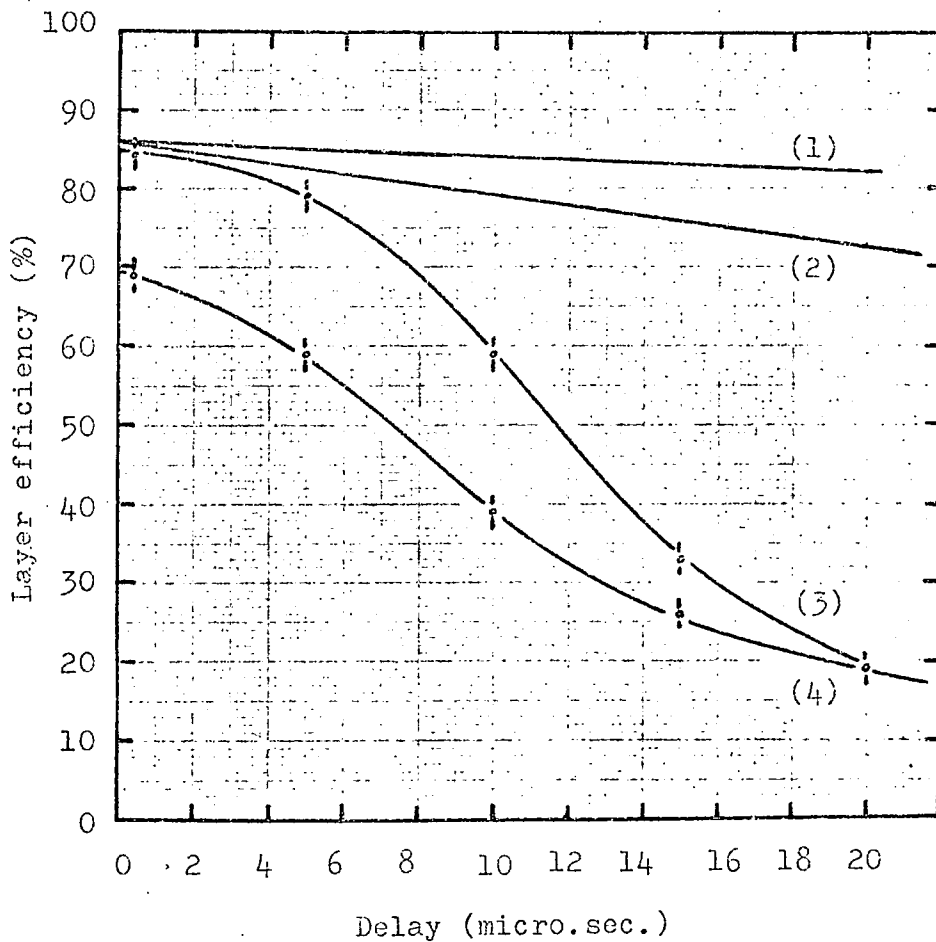

- (1) Conventional flash tubes (slow rate)
- (2) Conventional flash tubes (fast rate)
- (3) Flash tubes containing 0.04mm.Hg. pressure of water vapour.
- (4) Flash tubes containing 2.5mm.Hg. pressure of water vapour.

figure 3.12

comparable with that of ordinary tubes even at very slow rates. Group B did not show this effect with age. Groups C and D which were saturated and contained liquid water showed efficiencies comparable to those of conventional flash tubes, and also a high spurious rate; about 10%. These anomalous effects in high water content flash tubes will be discussed in chapter 6.

The recovery time of these tubes was also investigated. The tubes were pulsed twice on the passage of a particle, by means of two spark gaps with independent power supplies. The interval between the two pulses could be varied, and it was found that for an interval of up to a second the tubes which flashed on the first pulse could reignite on the second. The recovery time could be reduced slightly by reducing the applied field, but this unfortunately had the added effect of decreasing the brightness of the flash, which had already shown a considerable decrease with increasing concentration of water vapour.

### 3.12 BIPOLAR RINGING PULSES.

A technique which reduces the clearing field effect without impairing the brightness of the flash is the use of a bipolar ringing high voltage pulse, obtained by employing an inductive load in place of the resistor  $R_1$  in figure 3.1. Since the applied field swings positive and negative the electrons and ions will oscillate instead of moving in one direction, and hence the number deposited on the flash tube walls will be less, and in any case, approximately the same number will be deposited on both sides of the tube so that any effect due to them will be cancelled out.

The efficiency against delay curves for a repetition rate of 1/10 sec./tube are shown in figure 3.13 for a bipolar ringing pulse and for a ringing pulse which does not go negative, both with the same decay constant. The two pulses are shown in figure 3.14. It can be seen that the efficiency for a bipolar pulse is higher than for the monopolar pulse, and in fact coincides with Lloyd's theoretical curve with  $FQ = 10$ , showing that no clearing fields are built up.

The recovery time when a bipolar ringing pulse is employed is still of the order of 1 second.

EFFICIENCY AS A FUNCTION OF DELAY  
FOR MONOPOLAR AND BIPOLAR RINGING PULSES

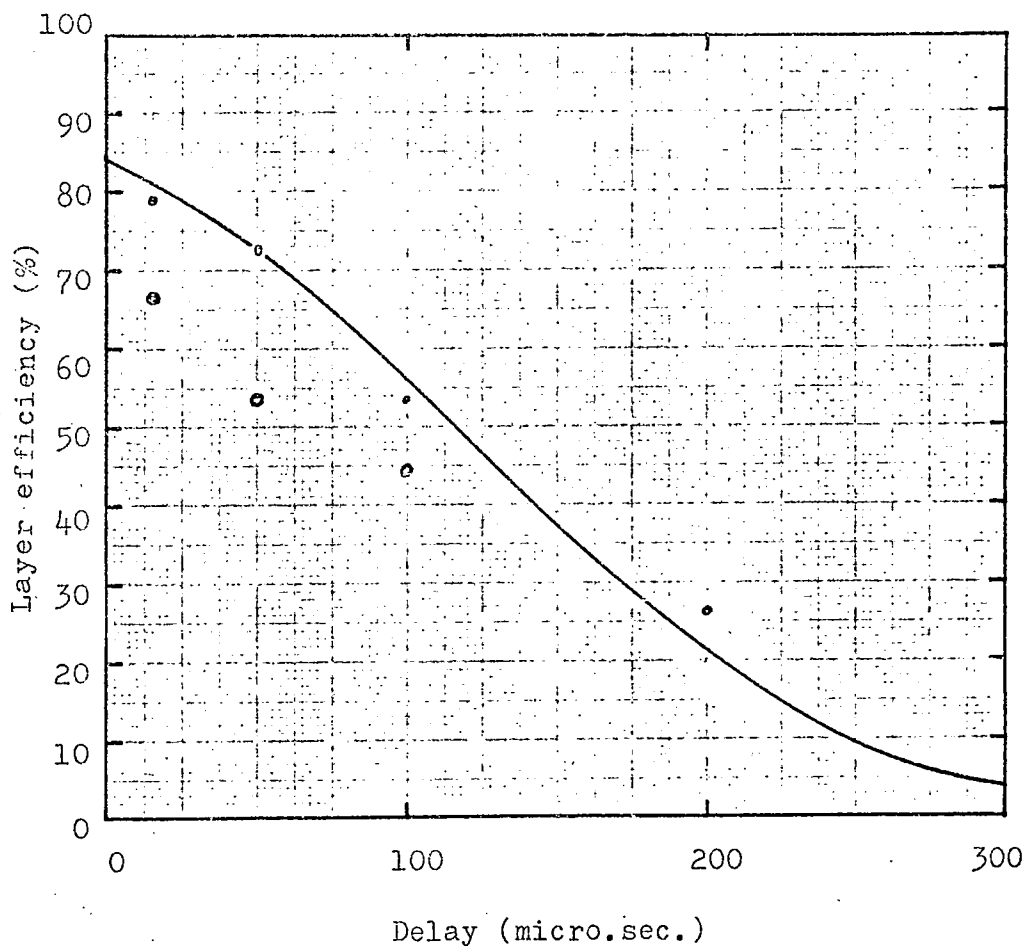

- Monopolar ringing high voltage pulse
- Bipolar ringing high voltage pulse
- Theoretical curve for  $FQ = 10$

figure 3.13

MONOPOLAR AND BIPOLAR RINGING PULSES

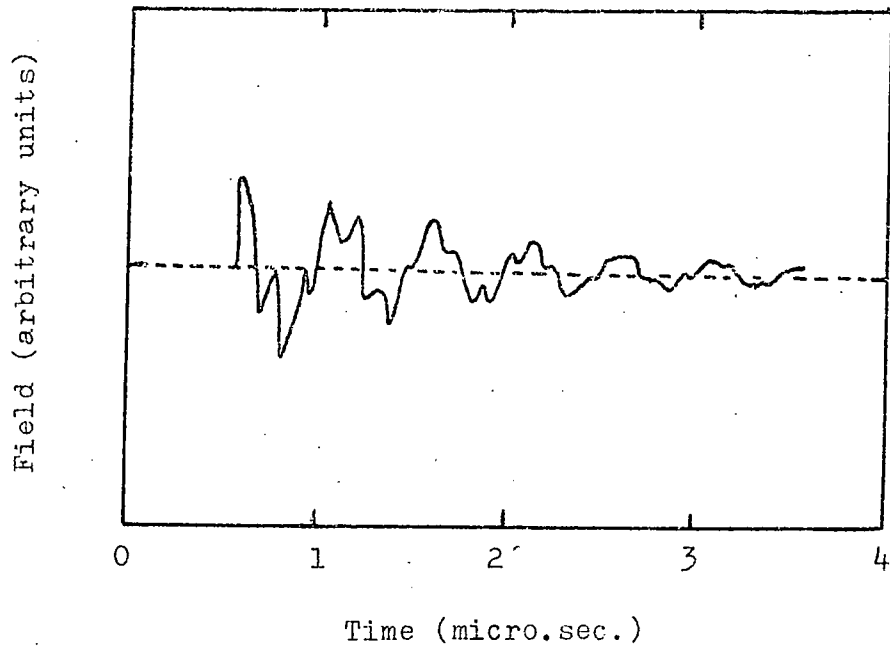

(a)

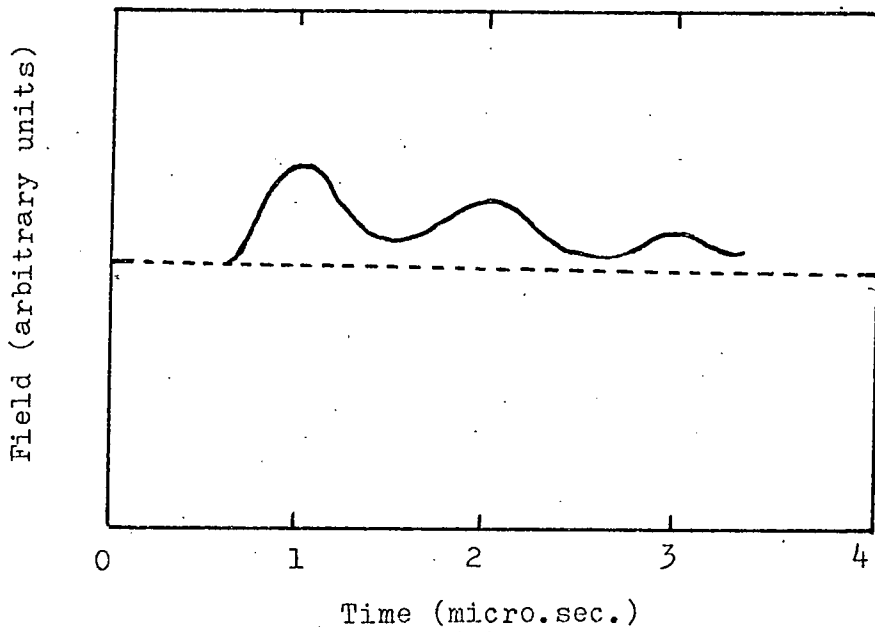

(b)

figure 3.14

### 3.13. LONG TERM CLEARING FIELD EFFECT.

It has been mentioned that a second clearing field effect with time constants of the order of days has been observed. In order to determine whether this effect is due to the discharge, as is the short term effect, or due simply to the application of the high voltage pulse, the scintillator telescope was placed at one side of the broad array, and the detector operated at a high repetition rate, of about 1/minute/tube, and minimum delay, for several days, so that large clearing fields were built up. The efficiency was then measured at 50 micro sec. delay in the following conditions:-

- (a) At the same side of the array.
- (b) At the other side of the array where few flashes had occurred.
- (c) As in (a)

It was estimated that no cosmic ray which triggered the apparatus in the initial high efficiency run would cause to flash any tube which could flash in run (b), assuming that cosmic rays travel in straight lines. Obviously some flashes did occur on the other side of the array, but these were relatively few.

Run (c) was carried out to ensure that any difference between runs (a) and (b) was not merely a function of time.

It was found that the efficiency in run (b) was  $44.4\% \pm 1.6\%$ , which is considerably higher than the value found in the other two runs ( $35.5 \pm 1.6\%$ ), showing that the long term clearing field effect also is due to the actual discharge.

If the inefficient tubes were then operated with a high voltage pulse of the opposite polarity, the efficiency at once rose to a higher value, which persisted even if a pulse of the original polarity was used again.

### 3.14. DEPENDENCE OF LONG TERM EFFECT ON APPLIED FIELD.

The dependence of the long term clearing field effect on the applied field was investigated in the following way. The flash tube array was operated at a rate of 1/minute/tube at zero delay, using a high voltage pulse of 40 micro sec. RC constant and different heights, for a period of two days. The efficiency at 50 micro sec. delay, using a repetition rate of 1/30 minutes/tube, was then measured, for the same voltage pulse height and length. The efficiency for the 50 micro sec. delay run was found to be low, even though the rate was such that no clearing fields

should have been built up during the run. It was concluded therefore, that a field was built up during the 2 day high efficiency run which did not decay immediately. A graph of efficiency as a function of applied field for these runs is given in figure 3.15, and shows that the long term effect comes into operation for applied pulse heights above about 6 KV/cm., although it may be that the effect was not observed for lower fields simply because there was not sufficient time for the field to build up to a detectable level.

Possible mechanisms for the long term clearing field effect are polarization of the glass by the high fields which appear across it when the tube discharges, or electrons which are trapped in the glass surface and therefore not free to move to neutralise positive ions on other parts of the tube.

### 3.15. SUMMARY.

In this chapter experimental evidence has shown that for high repetition rates and long high voltage pulses, a reduction in efficiency results, which can be explained in terms of clearing fields caused by deposition of charge on the walls of the flash tube due to the discharge, the amount depending on the length of the high voltage pulse, and it has been suggested that these fields decay with time constants determined by conduction of electrons over the glass surface.

A long term clearing field effect with time constants of the order of days has also been detected, and this could be due to polarization of the glass, or electrons trapped in the glass.

Various methods of reducing the clearing field effect have been tried. Tubes coated with a conducting layer of stannic oxide were not successful. Tubes with a high water vapour content show no clearing field effect for repetition rates of 1/10 sec/tube, and have the added advantage for machine experiments of short sensitive time. However, they have the disadvantage of low intensity, and the recovery time is as long as for ordinary flash tubes, i.e. of the order of 1 second. It appears that the amount of water vapour which should be used may be critical if anomalous effects are to be avoided.

A bipolar ringing pulse shows no clearing field effect with repetition rates of up to 1/10 sec/tube, without the disadvantage of reduced brightness, but the recovery time is still high. If the tubes

LONG TERM CLEARING FIELD EFFECT

EFFICIENCY AS A FUNCTION OF APPLIED FIELD

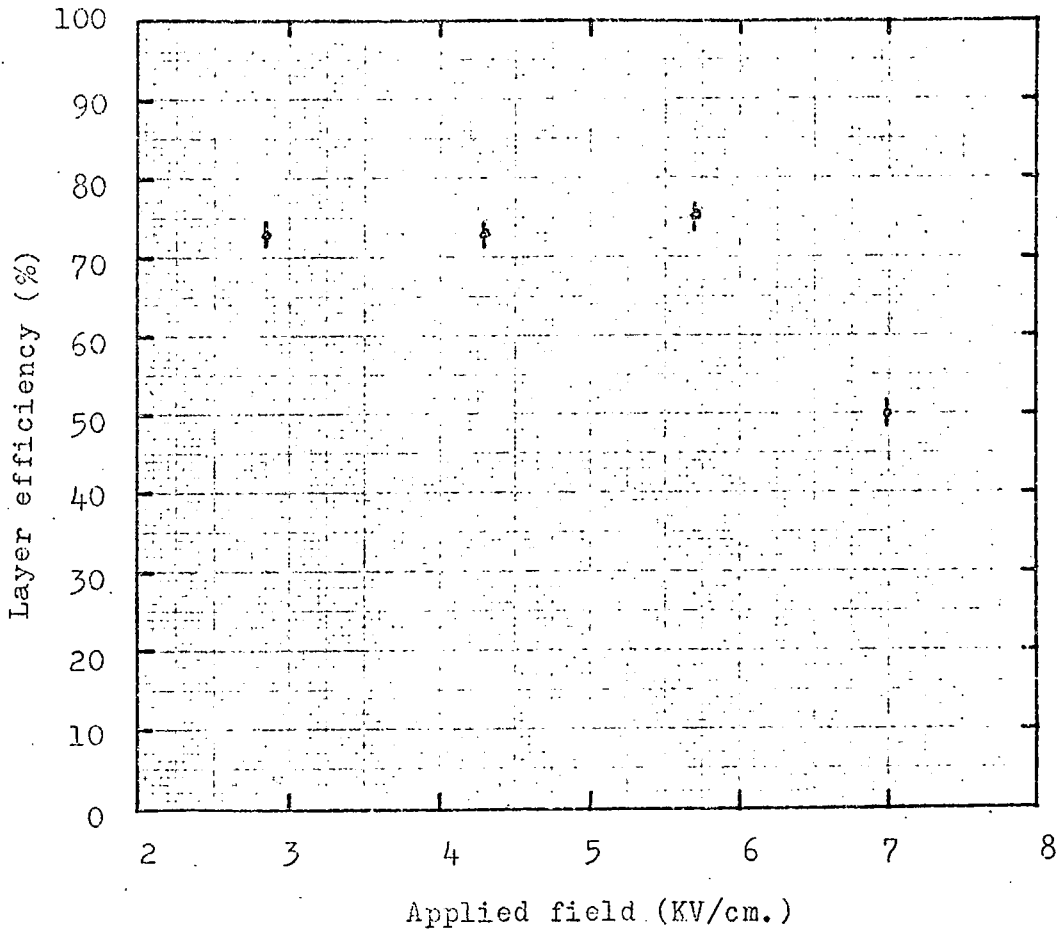

figure 3.15



were to be used for machine experiments the sensitive time could be reduced by adding, for example, iodine, which has a high affinity for free electrons.

The factor which now limits the use of flash tubes at high repetition rates is the long recovery time.

The next chapter describes experiments designed to study the nature of the discharge which takes place in flash tubes.

## CHAPTER 4.

### THE DISCHARGE MECHANISM IN FLASH TUBES.

#### 4.1. INTRODUCTION.

The previous chapter dealt with investigations into the clearing fields which are responsible for the deviation from the theory, based on a diffusion process only, of the efficiency against delay curves. It was concluded that the clearing fields were caused by charge deposited on the walls of the flash tube during high voltage pulse. Light has been shed on the nature of the discharge producing this charge, by experiments which will be described in this chapter.

#### 4.2. APPARATUS.

The light output from flash tubes has been observed using a Mullard 53 AVP. The photomultiplier was shielded from electromagnetic radiation, directly coupled into 50 ohms, and its power supply was filtered. Only when the oscilloscope probe was connected to the flash tube electrodes for high voltage pulse measurements, effectively by-passing the filter, was interference from the spark gaps observed on the oscilloscope, and even then it was at a comparatively low level. The photomultiplier was calibrated using a point source and employing the inverse square law, and was found to be linear for signals up to 2 volts. (35)

The output from the photomultiplier was recorded by photographing the trace on a 551 Tektronix oscilloscope.

#### 4.3. THE DISCHARGE MECHANISM.

Two basic breakdown mechanisms are known in gas discharge theory; streamer breakdown and the Townsend mechanism. In the former, electrons accelerated by the electric field cause further ionisation; an electron avalanche is built up to the critical size and breakdown results. In the Townsend discharge, the electron is accelerated and causes ionisation, but the avalanche so formed does not reach the critical size. However, positive ions drift to the cathode and liberate further electrons from it, and electrons are also produced by photoemission from the electrodes. These in turn give more ionisation until eventually enough electrons are produced to cause breakdown. The first mechanism is very fast; the electron avalanche travelling at about  $10^7$  cm/sec., and the rate at which the discharge crosses the gap is about  $10^8$  cm/sec. Fields of approximately 5KV/cm are required. The latter process is much slower, taking times of the order of micro seconds, and can take place at much lower fields.

The fields required to cause breakdown in flash tubes were investigated by measuring the efficiency as a function of applied field. The results for different high voltage pulse lengths are shown in figure 4.1. It can be seen that for longer high voltage pulses breakdown occurs at fields as low as 1 KV/cm., thus favouring a Townsend mechanism. For the shorter pulse, (0.4 micro sec.R.C.) however, a much higher field, about 5 KV/cm, is needed before breakdown will occur. This indicates that for short high voltage pulses when there is insufficient time for a Townsend discharge to develop, streamer breakdown will occur provided the field is high enough. In intermediate cases, for high fields and long pulses, the discharge mechanism is probably a mixture of the two.

Figure 4.2. shows drawings of light pulses and the corresponding high voltage pulses taken from the oscilloscope trace. The high voltage pulses have a rise time of about 70 n.sec. a) shows the light output for a 0.4 micro sec. RC high voltage pulse of height 7 KV/cm. The discharge appears to start within 100 n.sec. of the high voltage pulse, and reach its peak in 200 to 300 n.sec., indicating a fast discharge process. The pulse in b) obtained with a high voltage pulse of 40 micro sec. RC and

VARIATION OF LAYER EFFICIENCY WITH APPLIED FIELD

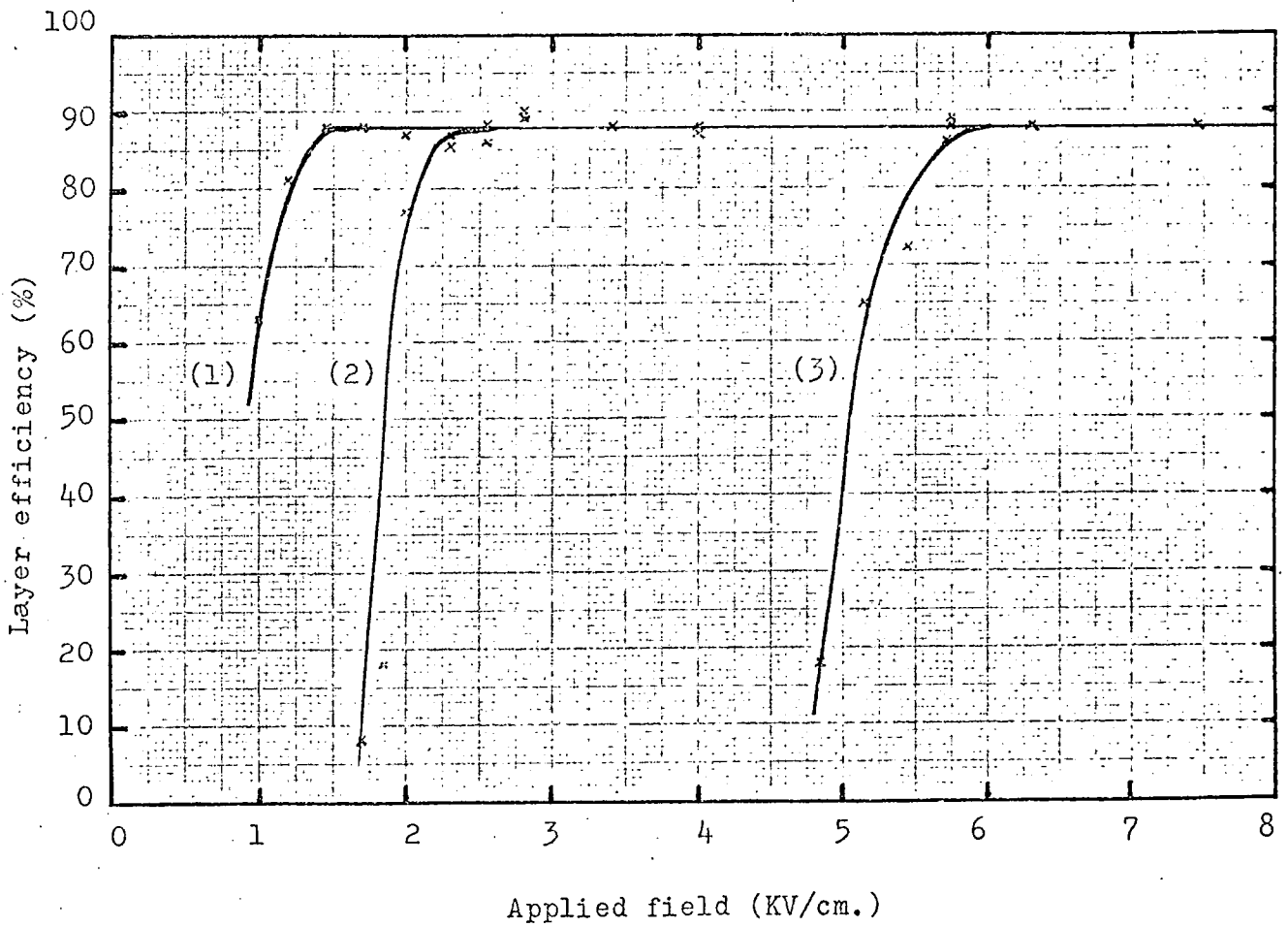

- (1) R.C. = 40.0 micro.sec.
- (2) R.C. = 4.0 micro sec.
- (3) R.C. = 0.4 micro sec.

figure 4.1

LIGHT PULSES FROM FLASH TUBES  
FOR DIFFERENT H.T. PULSE LENGTHS

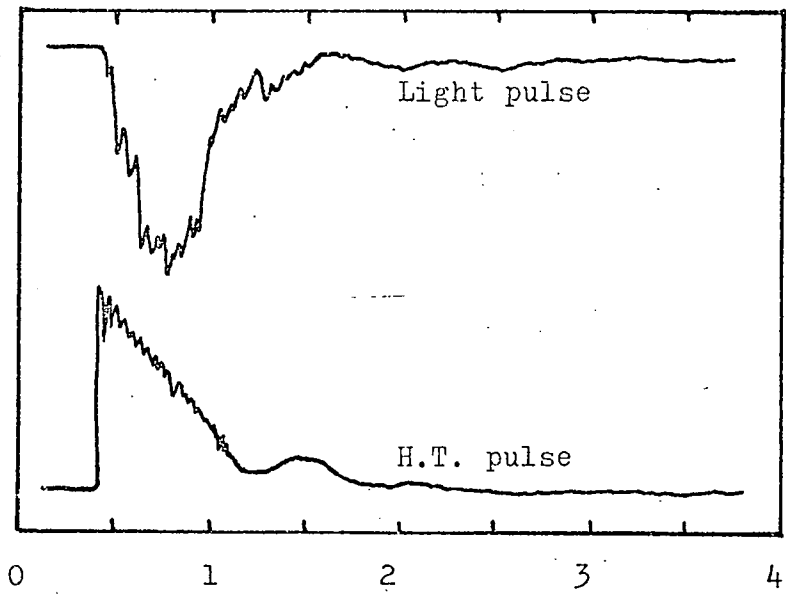

Time (micro.sec)

(a)

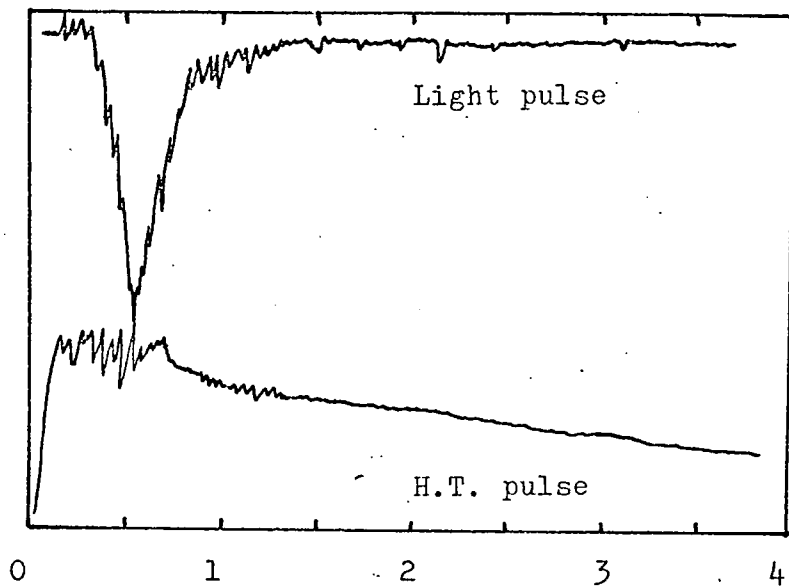

Time (micro.sec.)

(b)

figure 4.2

height 4KV/cm does not start until 0.5 micro sec. after the high voltage pulse has reached its peak, indicating a much slower build up of the discharge.

#### 4.4. PROBABILITY OF A DISCHARGE OCCURRING.

The probability that a tube will flash when an ionising particle has passed through it will depend on a number of factors, two of which are high voltage pulse height and length. These have been discussed in the previous section, and provided they are above a critical value, should have no effect on the probability.

The dependence of the probability on the delay between the passage of a particle and the application of the high voltage pulse was discussed in chapter 3. In order to make experimental points fit the diffusion theory it was found necessary to adjust a parameter  $F$ , the probability of a single electron initiating a discharge. The value of  $F$  will be largely determined by the formative distance  $D_F$  of the discharge, i.e. the average distance required for an electron to avalanche to the critical size. If an electron is within a distance  $D_F$  of the anode side of the tube when the high voltage pulse is applied it will not start a discharge.  $D_F$  will be affected by the rise time and the height of the high voltage pulse. Figure 4.3. shows that the efficiency decreases with increasing high voltage pulse rise time. If the applied field rises slowly to its peak value, some electrons will reach the wall of the tube before their avalanches have reached the critical size. Figure 4.4. shows light pulses obtained with high voltage rise times of 70 n.sec (a) and 1 micro sec. (b) and confirms that the discharge develops much more quickly for a fast rising high voltage pulse.

#### 4.5. THE MAGNITUDE OF THE DISCHARGE.

In chapter 3 it was shown from studies of the duration of the light output, that the discharge in flash tubes is self quenching when the field due to charge separation backs off the applied field to such an extent that breakdown can no longer be sustained. The magnitude of the discharge must therefore be determined by the magnitude of the applied field. The size of the discharge as a function of applied field was investigated by measuring the light intensity, which is assumed to be proportional to the energy of the discharge. The photomultiplier described in section 4.2. was

VARIATION OF EFFICIENCY WITH APPLIED FIELD  
FOR DIFFERENT H.T. PULSE RISE TIMES

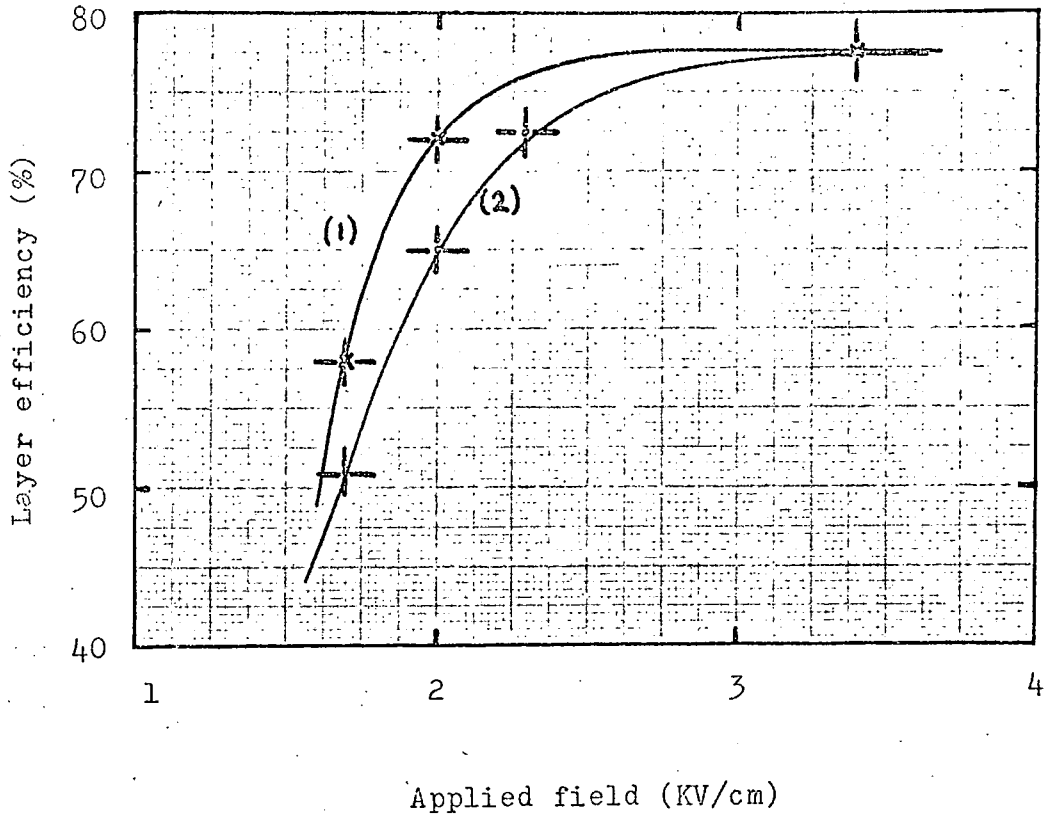

- (1) Rise time 70 n.sec.
- (2) Rise time 1 micro.sec.

figure 4.3

LIGHT PULSES FROM FLASH TUBES

FOR DIFFERENT H.T. PULSE RISE TIMES

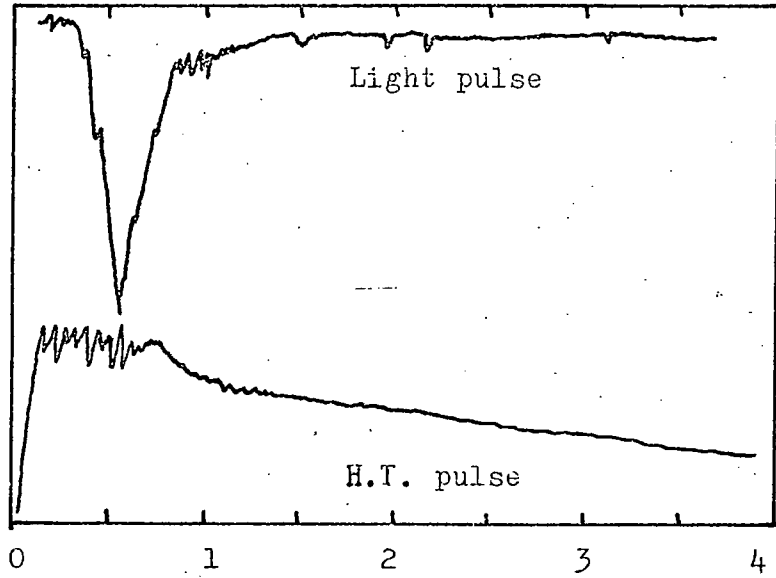

Time (micro.sec.)

(a)

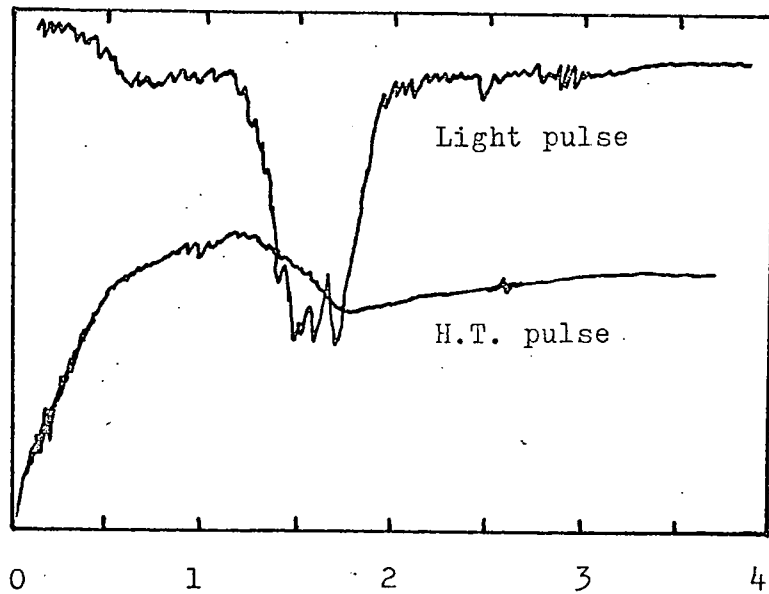

Time (micro.sec.)

(b)

figure 4.4



used, but because of the direct coupling the output had to be integrated to obtain the light intensity. This is plotted as a function of applied field in figure 4.5. and shows a variation which can be expressed as:-

$$I = V^\beta$$

where :-

$$I = \text{intensity}$$

$$V = \text{applied field (KV/cm)}$$

$$\beta = 2.1 \pm 0.6$$

Treating the flash tube as a capacitor, the energy of the field is given by:-

$$E = \frac{1}{2} CV^2$$

and if one assumes that a constant fraction of the energy goes into the discharge, the experimental results agree with the capacitor model of a flash tube.

Using the value of 4.25 pF for the capacitance of the inside of a flash tube (see chapter 3) and assuming that the fraction of the energy of the field which goes into the discharge is approximately 1, the equation:-

$$Q = CV$$

gives the number of electrons involved in the discharge as  $2.5 \times 10^8 \text{ cm}^{-3} \text{ KV}^{-1} \text{ cm}$ .

#### 4.6. PROPAGATION OF THE DISCHARGE DOWN THE TUBE.

The light output from flash tubes of 4 lengths was measured, using a number of different high voltage pulse lengths from 0.4 to 40 micro sec RC. The duration of the light pulse was found to be independent of high voltage pulse length, but dependent on the length of the flash tube.

The results of Coxell et al (29) who found that the light pulse was longer than the high voltage pulse (a square pulse 3 micro. sec. long) and had a slight increase when the high voltage pulse was removed, are thought to be due to the integrating effect of the electronics used in conjunction with the photomultiplier. The increase when the high voltage pulse was removed was probably due to back discharges which are seen to occur, (figure 4.6)

LIGHT INTENSITY AS A FUNCTION OF APPLIED FIELD

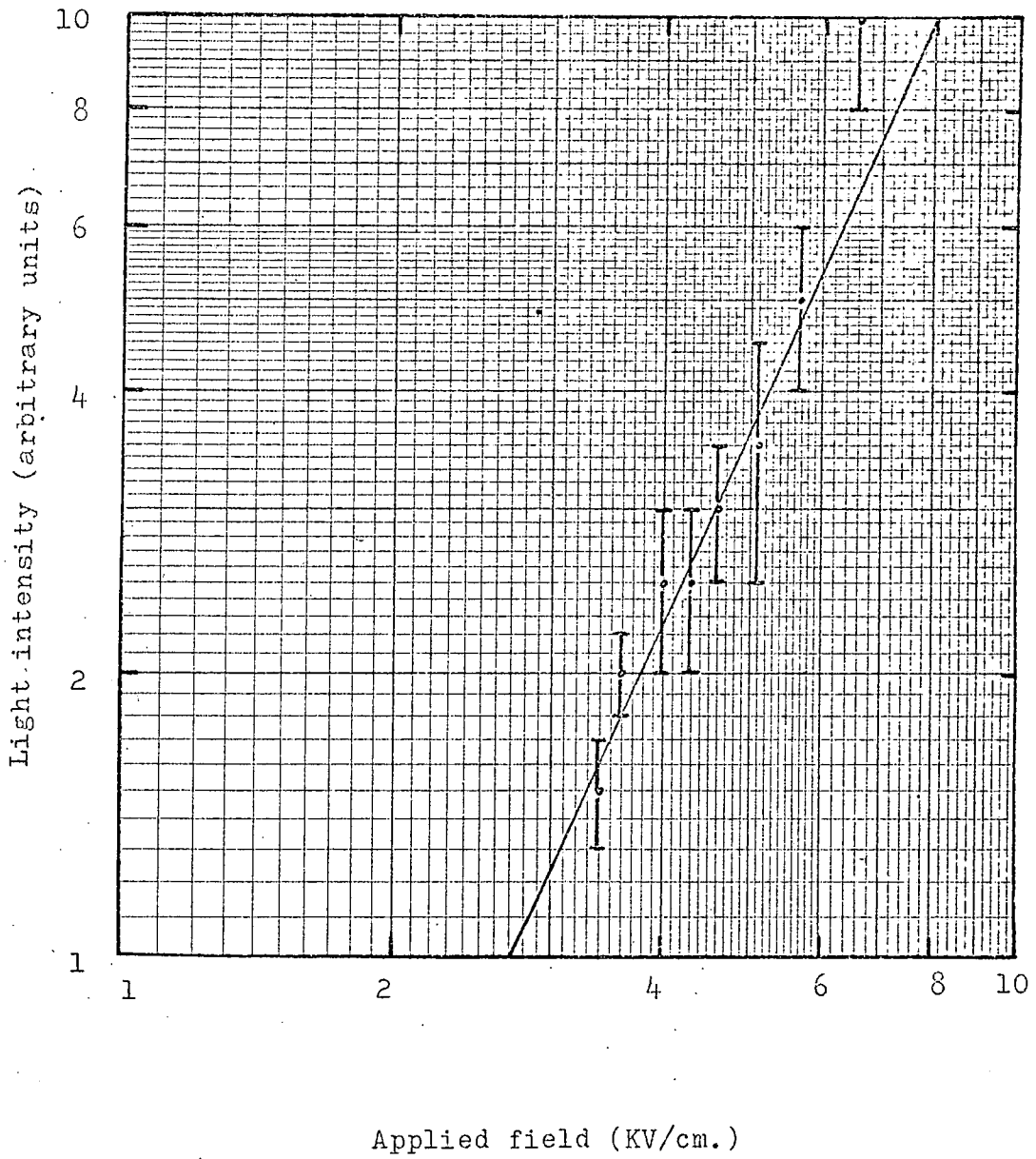

figure 4.5

LIGHT PULSE AND DIGITISATION PULSE  
FROM THE M.A.R.S. FLASH TUBE ARRAY

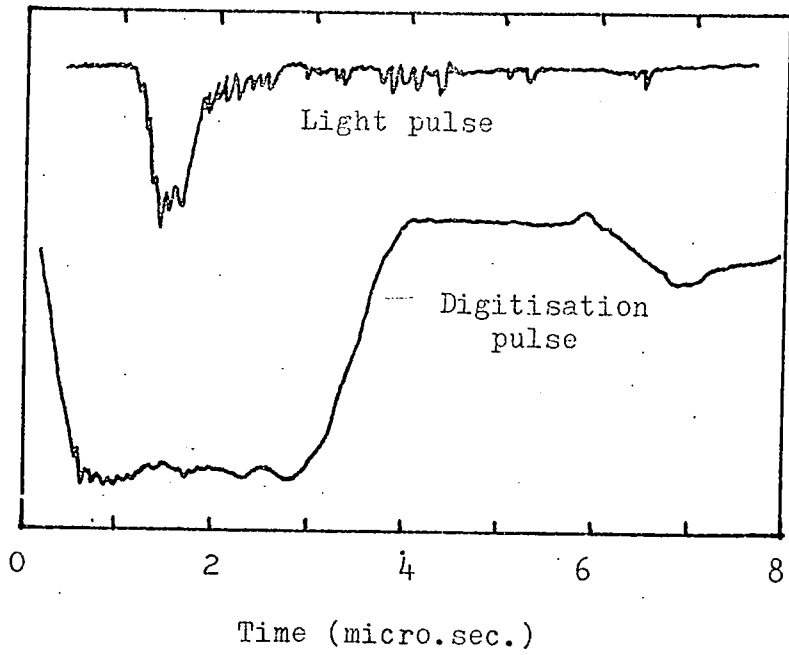

figure 4.6

especially when the high voltage pulse is removed, and are due to localised breakdown in the large field regions caused by charge deposited on the glass during the pulse.

A graph of light pulse length (width at base) against flash tube length (figure 4.7.) shows that the two are approximately proportional, indicating that the length of the light pulse is governed mainly by the time taken for the discharge to spread down the tube.

(The 30 cm tubes had a high water vapour content, and this may so modify the discharge and propagation mechanism as to explain the deviation of this point from the line.)

Further evidence for the dependence of light pulse length on the time taken for the discharge to spread down the tube is given by the light pulses from particles traversing the front and back of the tubes, shown in figure 4.8, obtained by placing the scintillator telescope in different positions along the length of the tubes. The pulse (a) corresponding to a particle traversing the front of the tube shows a sharp rise as the discharge starts near the photomultiplier, and a slow fall as it spreads to the far end of the tube, having already been switched off at the end near the photomultiplier, and the intensity decreases with distance from the photomultiplier. The pulse obtained from a particle traversing the back of the tube (b) is reversed. The rise is slow as the discharge spreads towards the front of the tube, and the fall is fast as it switches itself off.

From the graph of light pulse length against flash tube length it can be seen that the speed of propagation is about 0.24 cm. / n.sec., and that the time taken for the discharge to cross the tube is about  $150 \pm 50$  n.sec.

From the velocity of propagation it seems unlikely that the discharge is spread by electrons or ions since the diffusion of these particles down the tube would be too slow. Using the diffusion relationship:-

$$\bar{x} = \sqrt{2 Dt}$$

the time taken for an electron to traverse the length of the tube would be of the order of seconds.

DURATION OF DISCHARGE  
AS A FUNCTION OF FLASH TUBE LENGTH

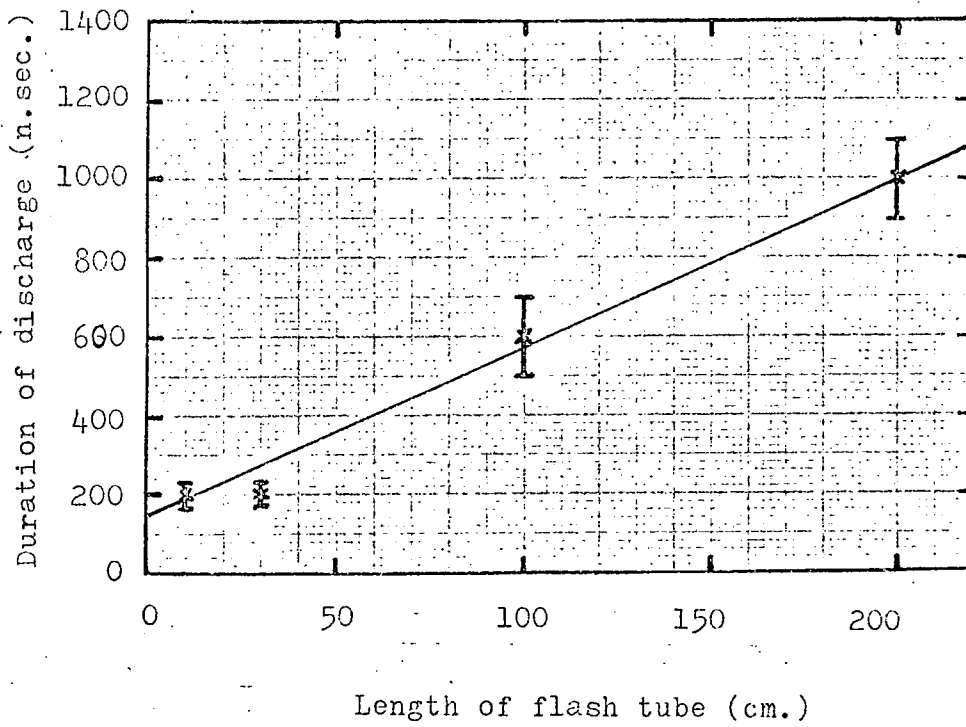
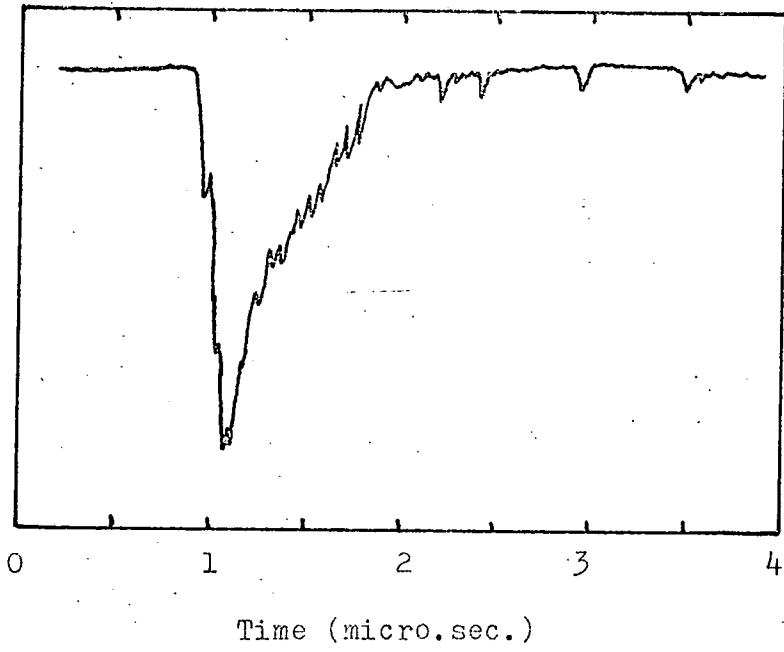
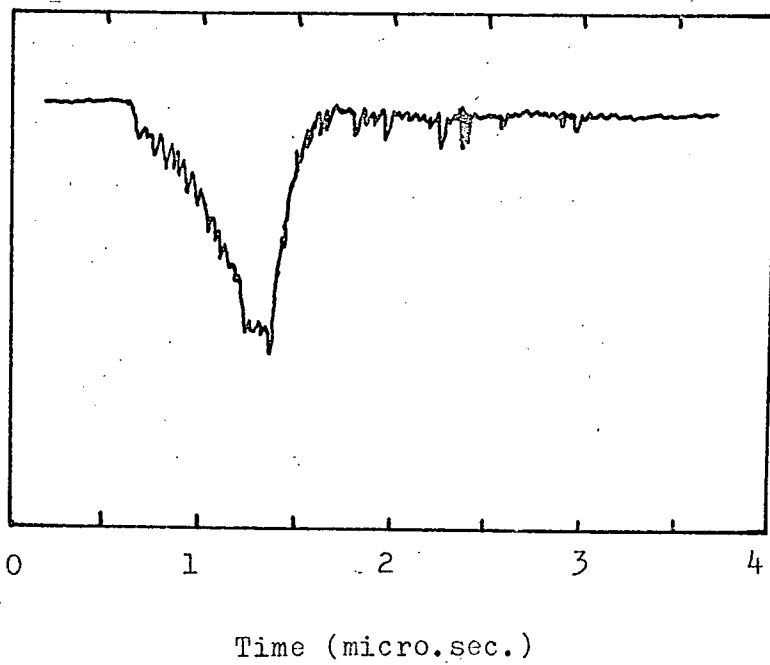

figure 4.7

LIGHT PULSES DUE TO PARTICLES  
TRAVERSING THE FRONT AND BACK OF THE TUBES



(a)



(b)

figure 4.8

The probable method of propagation is by ultraviolet photons from the discharge striking the flash tube walls at different points along the tube. These will knock out photoelectrons which in turn will initiate other discharges. Supporting evidence for this is given by the photographs in figure 4.9 of the light output from the side of a flash tube, where it can be seen that a number of individual discharges take place. In the first picture where a 40 micro sec. RC pulse was used, the discharge has spread down the whole tube, and about 1 discharge / cm is visible. The second picture shows a discharge for a 0.4 micro sec. RC high voltage pulse. This is confined to a small volume of the tube, showing that the discharge had not time to spread down the tube before the high voltage pulse was removed. In some cases for a high voltage pulse of this length the whole tube did light up. The difference is probably due to the jitter, typically a few hundred n.sec., on the start of the discharge.

#### 4.7. THE DIGITISATION PULSE.

Ayre and Thompson (7) have reported that a discharge in a flash tube is accompanied by an electrical signal which can be detected by a metal probe placed in front of the tube. This pulse is used in the M.A.R.S. experiment (Ayre et al (8)) as a method of digitising the flash tubes and enabling them to be run on line to an I.B.M. 1130 computer.

The "digitisation pulse" has been investigated, and has shed some light on the flash tube discharge mechanism. Figure 4.10 shows oscilloscope traces of digitisation pulse, light pulse, and the corresponding high voltage pulse. The light pulse can be seen to start when the high voltage pulse is approximately at its peak, and to rise in about 200 n.sec. Its length, about 600 n.sec., is independent of the high voltage pulse length. The digitisation pulse on the other hand, does not reach its peak until the light pulse, and hence the discharge, is over. Its rise time is about 1 micro sec., and its decay comparable to that of the high voltage pulse.

It is unlikely that the digitisation pulse is due to an electric field set up by the charge separation since this would

LIGHT FROM THE SIDE OF FLASH TUBES

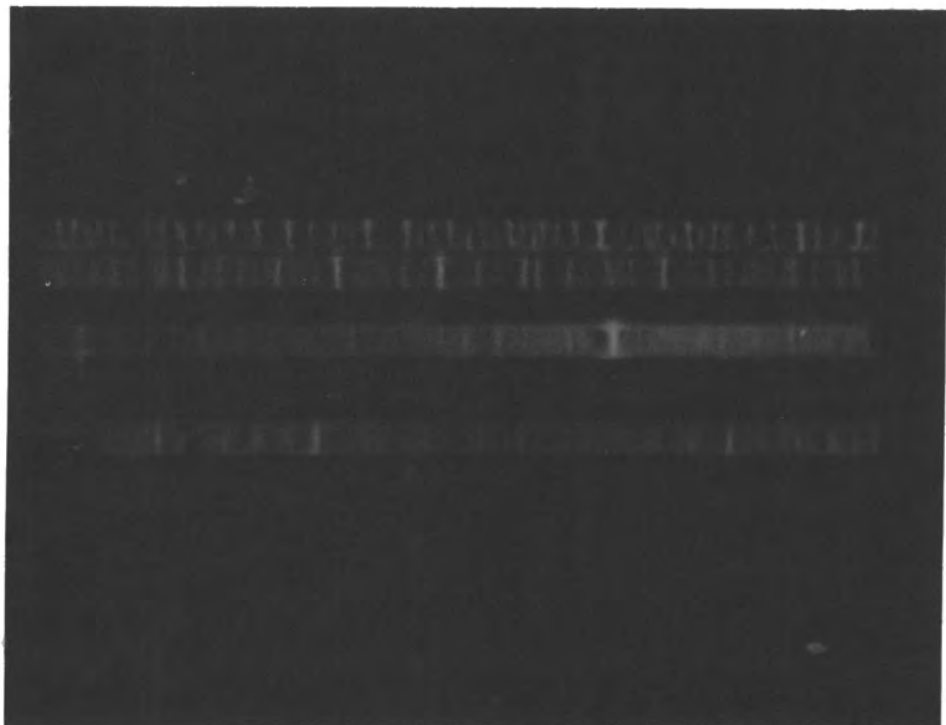

(a)

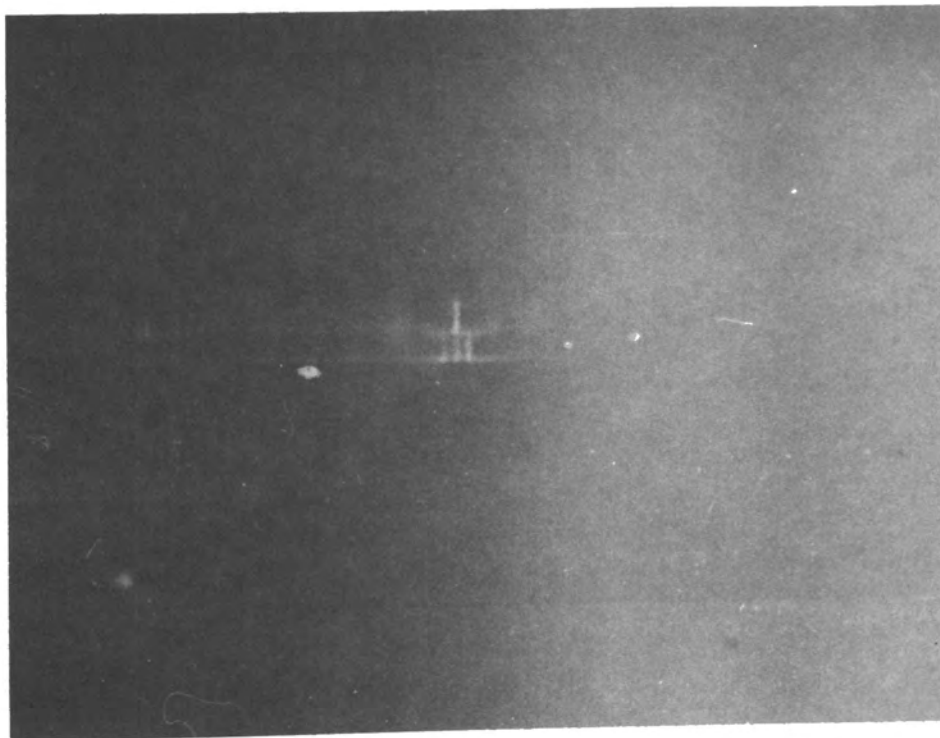

(b)

figure 4.9



LIGHT PULSE, H.T. PULSE AND DIGITISATION PULSE

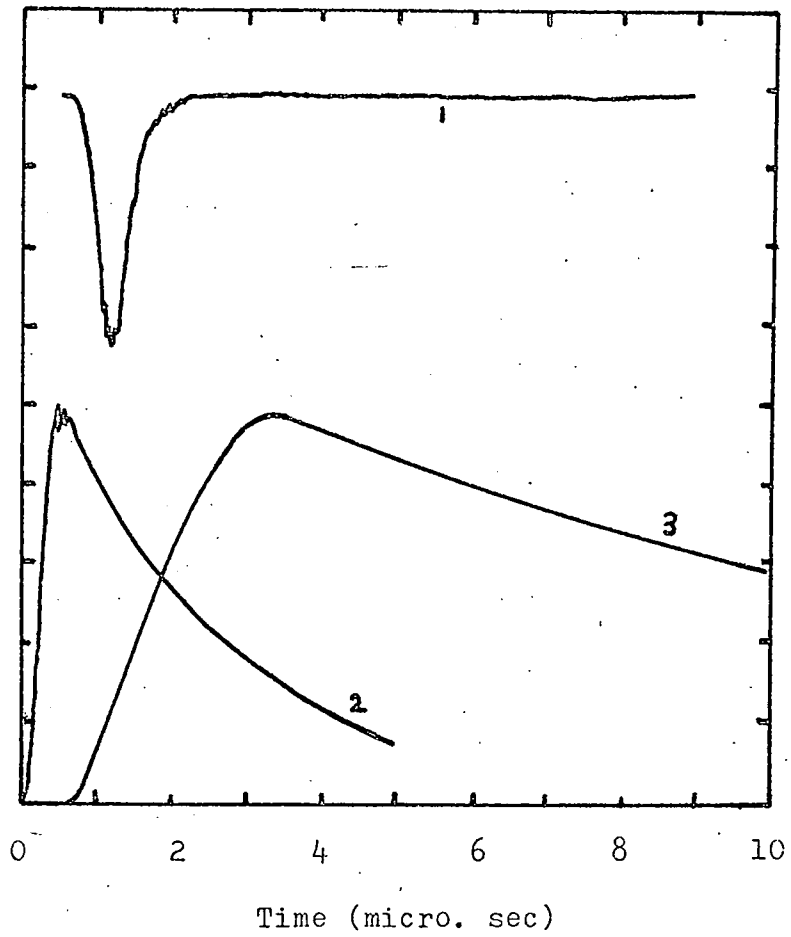

- 1 Light pulse
- 2 H.T. pulse
- 3 Digitisation pulse

figure 4.10



give a pulse of the wrong polarity; nor is it likely to be an electrostatic effect due to excess charge of one sign being pushed out of the discharge to the end of the tube, as suggested by Ayre and Thompson (7) since this mechanism would give different rise times for positive and negative digitisation pulses, corresponding to the different velocities of positive ions and electrons down the tube, and this is not observed.

If the effect were due to electromagnetic radiation from moving charges, it would be expected to have a much faster rise time, comparable with that of the light pulse, and to show a considerable decrease when the light pulse ends, i.e. when most of the electrons have stopped moving, instead of following the high voltage pulse.

The digitisation pulse is not likely to be due to a shock wave set up in the tube by the discharge since this would be expected to give much slower time constants, and a pulse of the same polarity regardless of the direction of the high voltage pulse.

The most probable explanation is simply capacitative coupling between the high voltage electrode and the probe. If the equivalent circuit of the flash tube and probe is assumed to be of the form given in figure 4.11, it is easy to see that if the impedance of the gas,

$$Z = R / (R \omega C + 1)$$

becomes very much smaller due to breakdown, the impedance between the high voltage electrode and the pulse becomes much smaller. The digitisation pulse will be present even when the tube does not flash, but it will be very much attenuated owing to the large impedance of the gas. In fact smaller digitisation pulse is observed when the tube does not flash.

A D.C. field of 2.8 KV/cm was applied to the tubes and the digitisation pulses due to breakdown caused, for example, by cosmic rays passing through the gas, were observed. If it is assumed that the decay of the digitisation pulse is an RC decay, the RC value was seen to change with time. The R and C in question are the resistance between the probe and ground, and the capacitance between the high voltage electrode and the probe. The latter

DIGITISATION PROBE AND EQUIVALENT CIRCUIT

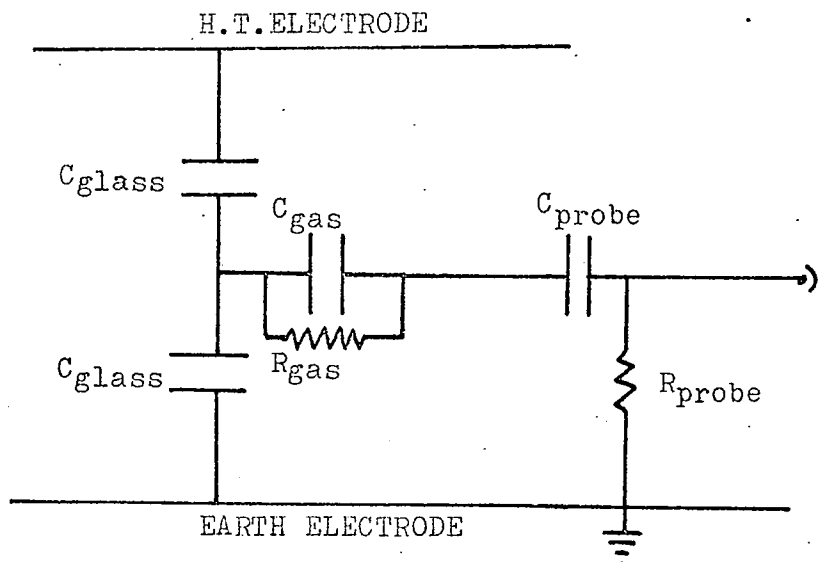
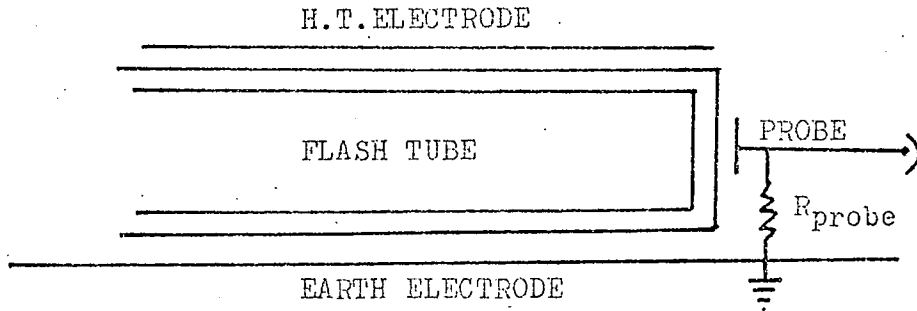

figure 4.11

varies when a discharge occurs because  $C_{\text{gas}}$  is effectively shorted out when the gas becomes conducting. Reducing  $R_{\text{probe}}$  by a factor 2 was shown to reduce the length of the digitisation pulse by a factor of approximately 2.

The pulse shape was plotted on a logarithmic scale (figure 4.12) and the slope of the curve and hence the RC value, was found as a function of time. Assuming R to be constant, the variation of C was plotted. (figure 4.12). The value of C for long times tends to about 500 pF which agrees quite well with the value of capacitance of 450 pF between the electrodes and the probe, measured with an AC bridge.

#### 4.8. BACK DISCHARGING.

When the DC field was removed exponentially, digitisation pulses both of the same polarity as the DC field, and of the opposite polarity were observed, the back discharges for several minutes afterwards. This clearly shows that localised fields still exist in the tube, large enough to support breakdown. These must be due to charge deposited on the walls of the flash tube during discharges. If these fields are large enough to produce breakdown, it seems reasonable to suppose that some field will exist in the tube for a considerable time after a discharge, and give rise to the clearing field effect described in chapter 3.

Back discharges will result in a quick reduction of the clearing field to a value where discharging can no longer occur. Figure 4.6. shows a cluster of back discharges when the high voltage field reverses polarity, indicating that a reversal of applied field encourages back sparking.

#### 4.9. SUMMARY.

It has been shown in this chapter that both streamer and Townsend discharges can occur in flash tubes, depending on the height and length of the applied high voltage pulse, and that in most cases the discharge mechanism is probably a combination of both. The probability of the discharge occurring has been shown to depend to some extent on the high voltage pulse parameters. An estimate has been made of the amount of charge deposited on the walls of a flash tube during a discharge, and one mechanism by

DIGITISATION PULSE FOR D.C.FIELD

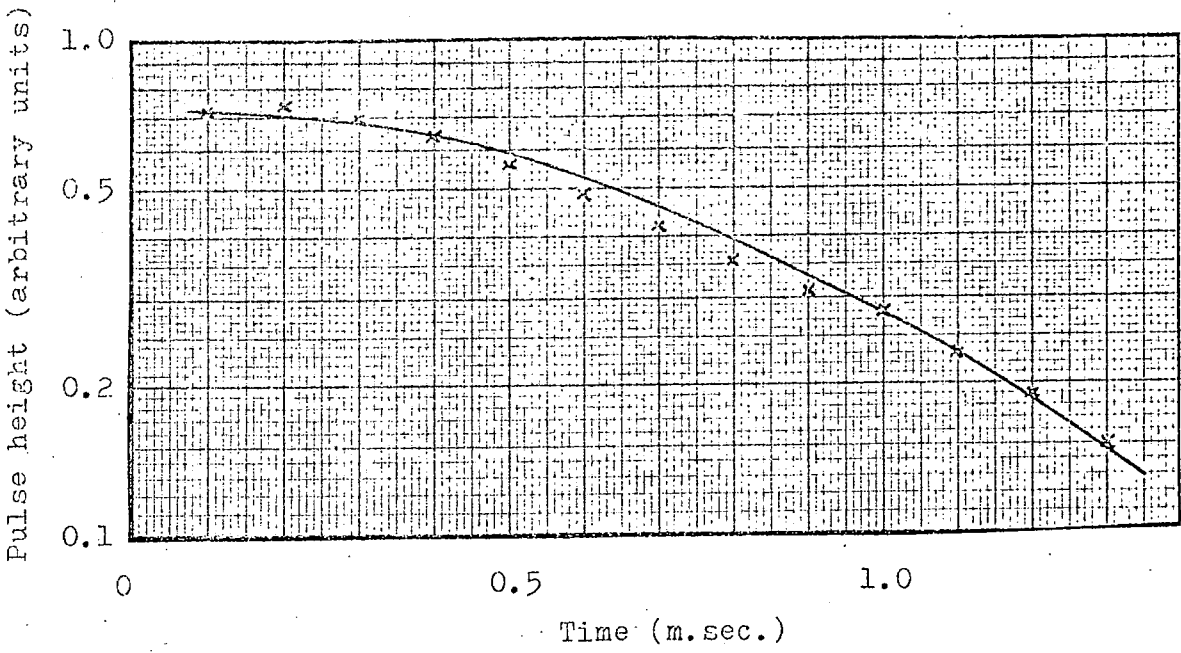

EFFECTIVE CAPACITY AS A FUNCTION OF TIME

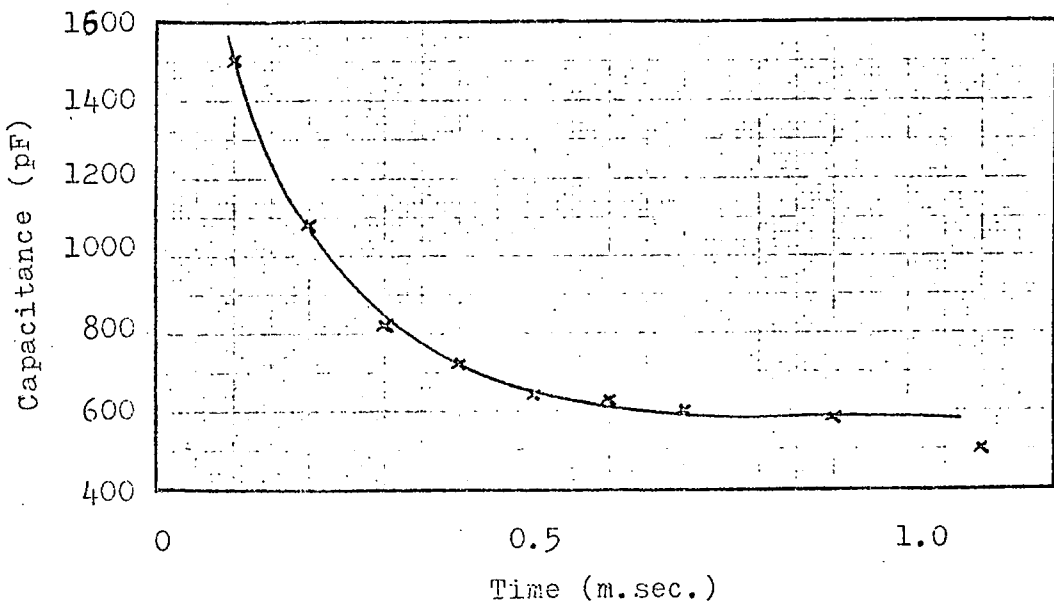

figure 4.12

which this charge may be neutralised, namely back discharging, has been studied.

In the next chapter an attempt will be made to calculate quantitatively the fields in flash tubes due to this charge, as a function of time after the discharge, and to correlate this with the clearing field effect described in the previous chapter.

CHAPTER 5:

THEORETICAL CONSIDERATIONS REGARDING FLASH TUBE EFFICIENCY.

5.1. INTRODUCTION.

The efficiency of flash tubes is determined by the number of electrons present when the high voltage pulse is applied, and at long delays this is governed mainly by diffusion of electrons to the walls where it is assumed that they have a high probability of capture. It has been shown, however, that when high repetition rates and long high voltage pulses are employed, another method for the removal of electrons becomes significant, namely that clearing fields are built up by charge deposited on the walls of the tube during the discharge, and these fields sweep electrons to the walls of the tube. In this chapter a random walk method is employed to solve the diffusion equation, with a drift term added, for electrons in a flash tube, and from the solution an estimate is made of the magnitude of the clearing fields built up in some of the experiments described in chapter 3. The formative distance of the discharge also affects the efficiency of the flash tubes, and this has been calculated using the random walk method, for the

flash tubes and high voltage pulse parameters used in the experiments.

### 5.2. DIFFUSION.

If the movement of electrons in a flash tube is assumed to be simply a diffusion process, the electron density at a given time can be expressed as the solution to the diffusion equation in cylindrical coordinates.

$$(1) \quad \frac{1}{D} \frac{\partial N}{\partial t} = \left[ \frac{\partial^2 N}{\partial r^2} + \frac{1}{r} \frac{\partial N}{\partial r} + \frac{1}{r^2} \frac{\partial^2 N}{\partial \theta^2} + \frac{\partial^2 N}{\partial z^2} \right]$$

where :-  
 D = diffusion coefficient  
 N = electron density.  
 t = time  
 r,  $\theta$ , z are the cylindrical coordinates.

The solution of this equation has been described by Lloyd (22) and the probability of an electron with initial position  $r_0$  remaining in the volume of the flash tube after a time t is given by:-

$$(2) \quad \rho(r_0, t) = 2 \sum_{\beta} \exp(-\beta^2 Dt/a^2) J_0(\beta r_0/a) / \beta J_1(\beta)$$

where :-  
 $\rho$  = probability of survival  
 a = radius of the flash tube  
 $\beta$  = positive roots of  $J_n(\beta) = 0$

Electrons produced from metastable atoms have also been considered, and found to be few compared with the number given by equation (2)

Assuming that other methods by which electrons may be removed from the tube, such as attachment by impurity molecules, are negligible compared with the diffusion process, the number of electrons remaining in the tube after a time t, and hence the efficiency, was found.

This was done by three methods, and all were found to agree. The first method was to integrate equation (2) over the whole flash tube, thus finding the survival probability of the average electron. The efficiency was then calculated from the equation:-

$$\eta = 1 - \exp(-FQ\rho)$$

where :-  
 $\eta$  = efficiency  
 Q = initial number of electrons  
 $\rho$  = survival probability  
 F = probability of one electron initiating a discharge.

The method assumes a Poissonian probability distribution.



The second method was to consider a cosmic ray track through the flash tube parallel to the y axis (see figure 5.1.) and to integrate  $\rho$  numerically over this track, thus finding the efficiency for a particle passing through a given position in the tube. The efficiency was then integrated over all possible tracks parallel to the y axis. This is valid to a first approximation since the angle of acceptance of the detector used is small.

The third method, which is the model closest to reality, was to take a large number of tracks in randomly selected positions across the flash tube, and for each of these tracks to calculate the survival probability of N electrons in randomly selected positions along the track.

$$N = Q a$$

where :-  
Q = ionisation / unit path length  
a = path length

The efficiency for each track was computed, and averaged over all tracks. While the last method is the most realistic of the three, its chief drawback is the amount of computer time required to obtain sufficient statistics to give consistent results. However, the second method is the limit of the third when the number of tracks and electrons in each track becomes very large, and a comparison showed the two to agree within statistical error. A set of curves showing flash tube efficiency as a function of delay for different values of FQ, obtained by the second method, which is the one employed by Lloyd, is given in figure 5.2.

The generally accepted value of primary ionisation by muons in neon at 760 mm.Hg is about 12 ion pairs /cm., however, at the delays considered ( > 10 micro sec.) secondary electrons will have been created and diffused apart. According to Lloyd the electrons thermalise within a micro.second, and other workers quote similar values. The value of Q therefore should be the total ionisation, given by Eyeions (31) as 33.6 ion pairs /cm./ atmosphere, and this value is used here.

It can be seen from figure 5.2. that the experimental values of flash tube efficiency for conditions in which no clearing fields are built up, lie on the curve corresponding to a value of FQ = 10. Thus according to Lloyd, the probability of a single electron initiating a discharge is about 0.3, assuming that the value of Q is correct.

FLASH TUBE SHOWING TYPICAL PATH OF AN ELECTRON

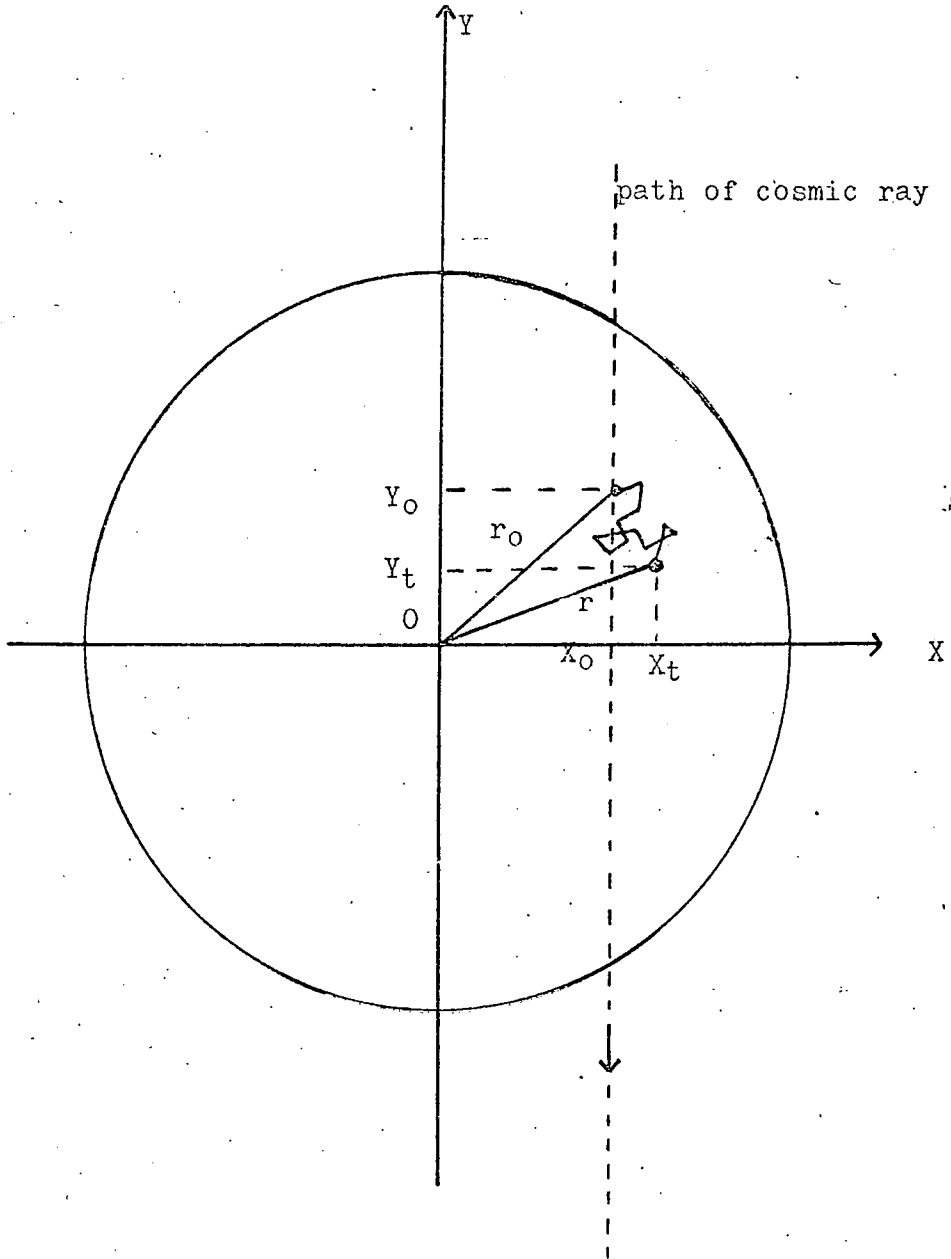

$X_0, Y_0$  = initial position

$X_t, Y_t$  = position at time  $t$

figure 5.1

EFFICIENCY AS A FUNCTION OF DELAY

( ANALYTICAL SOLUTION FOR DIFFERENT VALUES OF 'F' )

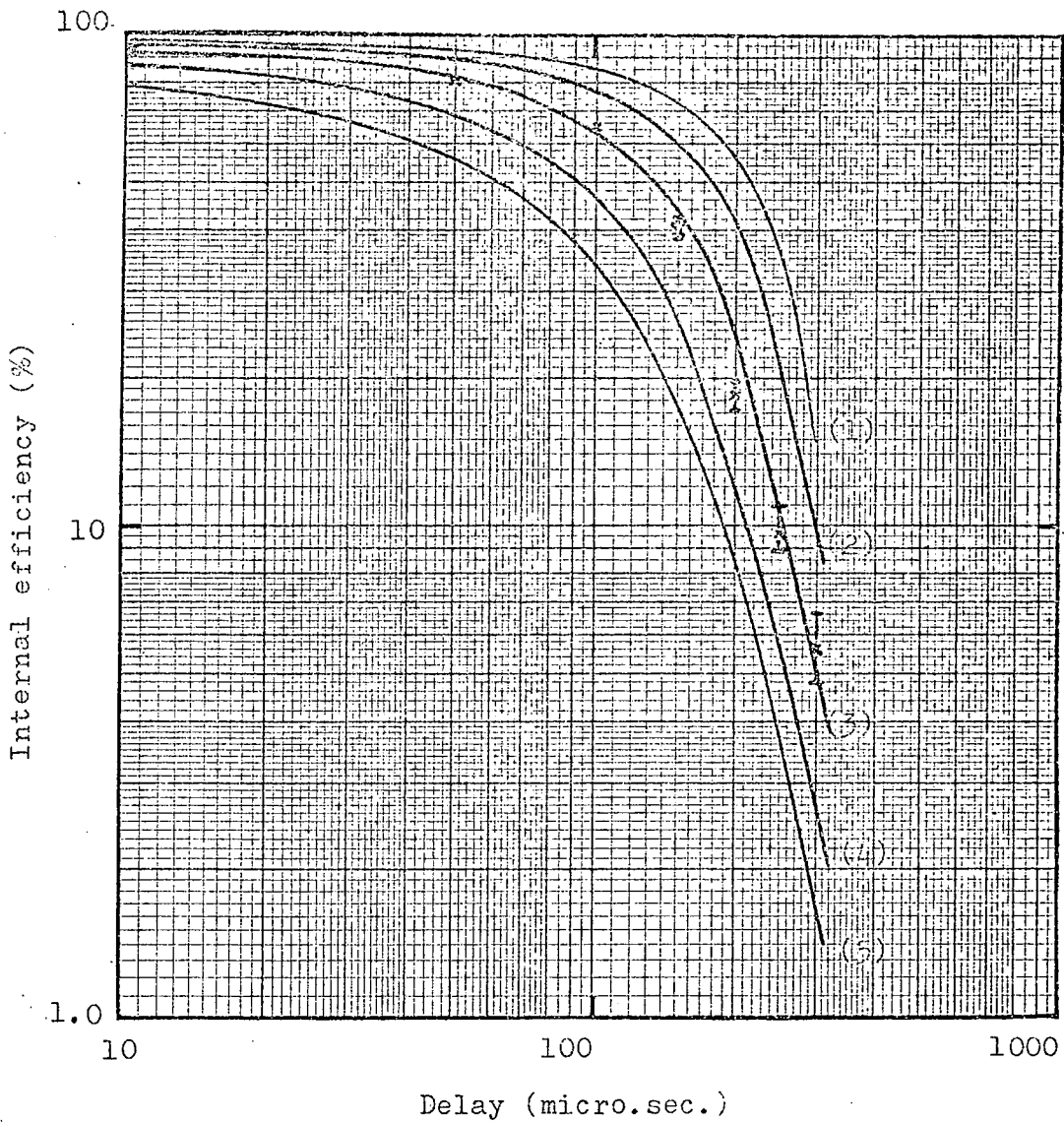

- (1)  $F = 1.0$
- (2)  $F = 0.6$
- (3)  $F = 0.3$
- (4)  $F = 0.15$
- (5)  $F = 0.1$

$F =$  probability of one electron initiating a discharge.

Ionisation = 33.6 ion pairs/cm.

$\times$  experimental points

figure 5.2

### 5.3. THE RANDOM WALK METHOD.

It has been shown in chapter 3 that when flash tubes are operated at high repetition rates, clearing fields are built up which sweep electrons out of the tube and cause a reduction in efficiency at long delays. If it is assumed that these clearing fields are uniform and act in a direction perpendicular to the electrodes, an analytical solution of the diffusion equation containing a drift term becomes impossible. It was therefore decided to attempt a solution by a random walk method.

Vertical tracks at different positions in the flash tube were considered, and using an IBM 360 computer, a large number (normally 1,000) random electron positions on the track were selected.

Using a time interval of 0.1 micro sec. and assuming the three dimensional equation:-

$$\begin{aligned} \bar{s} &= \sqrt{6 Dt} \\ \text{where } \bar{s} &= \text{root mean square distance travelled by} \\ &\quad \text{the electron} \\ t &= \text{time} \\ D &= \text{diffusion coefficient} = 1,800 \text{ cm}^2/\text{sec.} \end{aligned}$$

the movement of each electron was plotted as a function of time by selecting a random direction in space for each time interval, and moving the electron a distance  $\bar{s}$  in this direction. After each step it was required that the electron be inside the volume of the flash tube, ie. that its distance  $r = (x^2 + y^2)^{\frac{1}{2}}$  from the axis of the tube, ( $x = 0, y = 0$ ) was less than  $a$ , the tube radius. Diffusion out of the end of the tube was not considered. If this condition was not satisfied, the electron was considered lost from the tube.

The drift velocity of the electrons was taken into account by adding a constant distance,  $V dt$ , in the  $y$  direction after each step.

$$V = \text{drift velocity}$$

$$dt = \text{time interval} = 0.1 \text{ micro sec.}$$

Different values of time interval, down to 0.01 micro sec. were tried, and no difference in the results was observed, taking statistical error into account.

In order to check that the method gave the same results as the analytical solution of the diffusion equation, values of survival probability were computed by the random walk method for 1,000 electrons with a given initial position, and for the same initial position the probability was calculated by the analytical method.

The positions used and the corresponding probabilities at different delays are given in table 5.1. from which it can be seen that the agreement between the two methods is quite good.

TABLE 5.1.

DELAY. (micro sec.)	10	50	100	150	200	250	300
$r_0 = 0.0 \text{ cm.}$							
ANALYTICAL SOLUTION	1.0	0.70	0.52	0.14	0.06	0.03	0.01
RANDOM WALK	1.0	0.69	0.30	0.13	0.06	0.03	0.01
$r_0 = 0.7 \text{ cm.}$							
ANALYTICAL SOLUTION	0.36	0.12	0.05	0.02	0.01	0.005	0.002
RANDOM WALK	0.38	0.14	0.06	0.03	0.01	0.003	0.002

#### 5.4. FORMATIVE DISTANCE.

It was shown in section 5.2 that the experimental points for zero clearing field fitted the curve predicted for a value of  $F$ , the probability of one electron initiating a discharge, equal to 0.3. The probable reason for  $F$  not being unity is that an electron requires a finite distance in which to avalanche to the critical size. This is known as the formative distance  $D_F$ , and if an electron starts off within a distance  $D_F$  of the anode it will be unable to initiate a discharge. The formative distance will depend on the parameters of the applied high voltage pulse. For example, if the rise time is slow, more electrons will be swept to the wall of the flash tube before they can avalanche to the critical size. The higher the field the faster the electron avalanche grows, and the shorter the formative distance. This of course is counteracted by the increased velocity of the electrons, which tends to increase the formative distance. Since the efficiency of flash tubes, for a fixed delay, is constant above a certain field, it is assumed that the formative distance must also be constant.

The random walk method was employed to estimate the formative distance for the flash tubes and high voltage pulse parameters used in the experiments. Electrons with zero drift velocity were considered, and the additional condition was imposed that after a time  $t$ , the electron should not be within a distance  $D_F$ , on the  $y$  axis, from the anode wall of the flash tube. This gives rise to a situation in which the probability of an electron initiating

a discharge may be higher after a time  $t$  than at zero time, since it may start off within the formative distance, and diffuse out of it.

The efficiency as a function of delay was computed for different values of  $D_F$  and the results are given in figure 5.3. It can be seen that the experimental points fit quite well to a curve corresponding to  $D_F = 0.75$  cm. The point at 10 micro sec. delay differs significantly from the theoretical curve. This may be due to a difference in formative distance at such short delays, when the initial electrons are closer together, and the formative distance for a discharge initiated by two or more electrons may be significantly less than for a discharge started by only one electron (42). If this is so, it can be seen that the formative distance at 10 micro.sec. is negligible. At longer delays however, the points fit the  $D_F = 0.75$  curve quite closely.

From the data of Fischer and Zorn (32) for spark formative times, and the drift velocities of electrons, as a function of field, in neon, given by Von Engel (33) a field of 4 KV/cm would be expected to give a formative distance of 4.8 cm, and a field of 7KV/cm., 0.7 cm.

The reason for the discrepancy is probably that the discharge is not strictly streamer breakdown. If a discharge is not initiated by the streamer method, the electron density may reach the critical value by photoionisation and photoemission from the walls of the flash tube, thus decreasing the effective formative distance.

#### 5.5. DRIFT VELOCITY.

The efficiency as a function of delay was computed by the random walk method for different values of drift velocity both in the same direction as, and opposing the applied field, and with  $D_F = 0.75$  cm. The results are given in figures 5.4 and 5.5. Velocities of up to about  $10^3$  cm/sec. make very little difference to the efficiency. This velocity corresponds to a clearing field of less than  $10^{-3}$  V/cm according to the data of Pack and Phelps (28).

It is evident that drift velocities which oppose the applied field give rise to higher efficiencies than drift velocities in the same direction as the applied field. This is obviously due to the fact that in the former case electrons are swept away from the anode, giving them a greater distance over which to avalanche, while in the

EFFICIENCY AS A FUNCTION OF DELAY

(RANDOM WALK SOLUTION FOR DIFFERENT FORMATIVE DISTANCES)

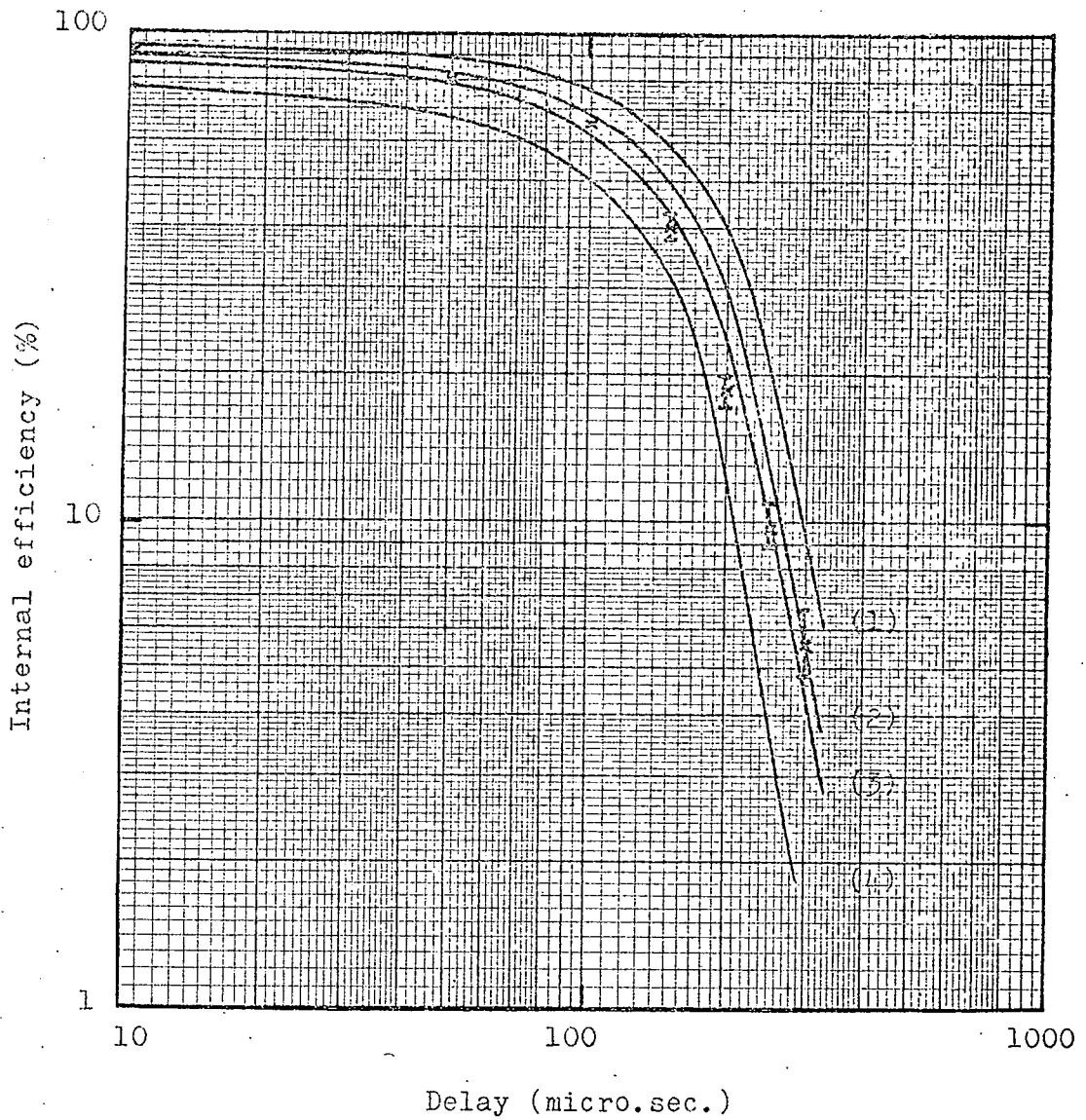

- (1) Formative distance = 0.0cm.
- (2) Formative distance = 0.7cm.
- (3) Formative distance = 0.8cm.
- (4) Formative distance = 1.0cm.

Ionisation = 33.6 ion pairs/cm.

$\times$  experimental points

figure 5.3

EFFICIENCY AS A FUNCTION OF DELAY

FOR DRIFT VELOCITIES OPPOSING THE APPLIED FIELD

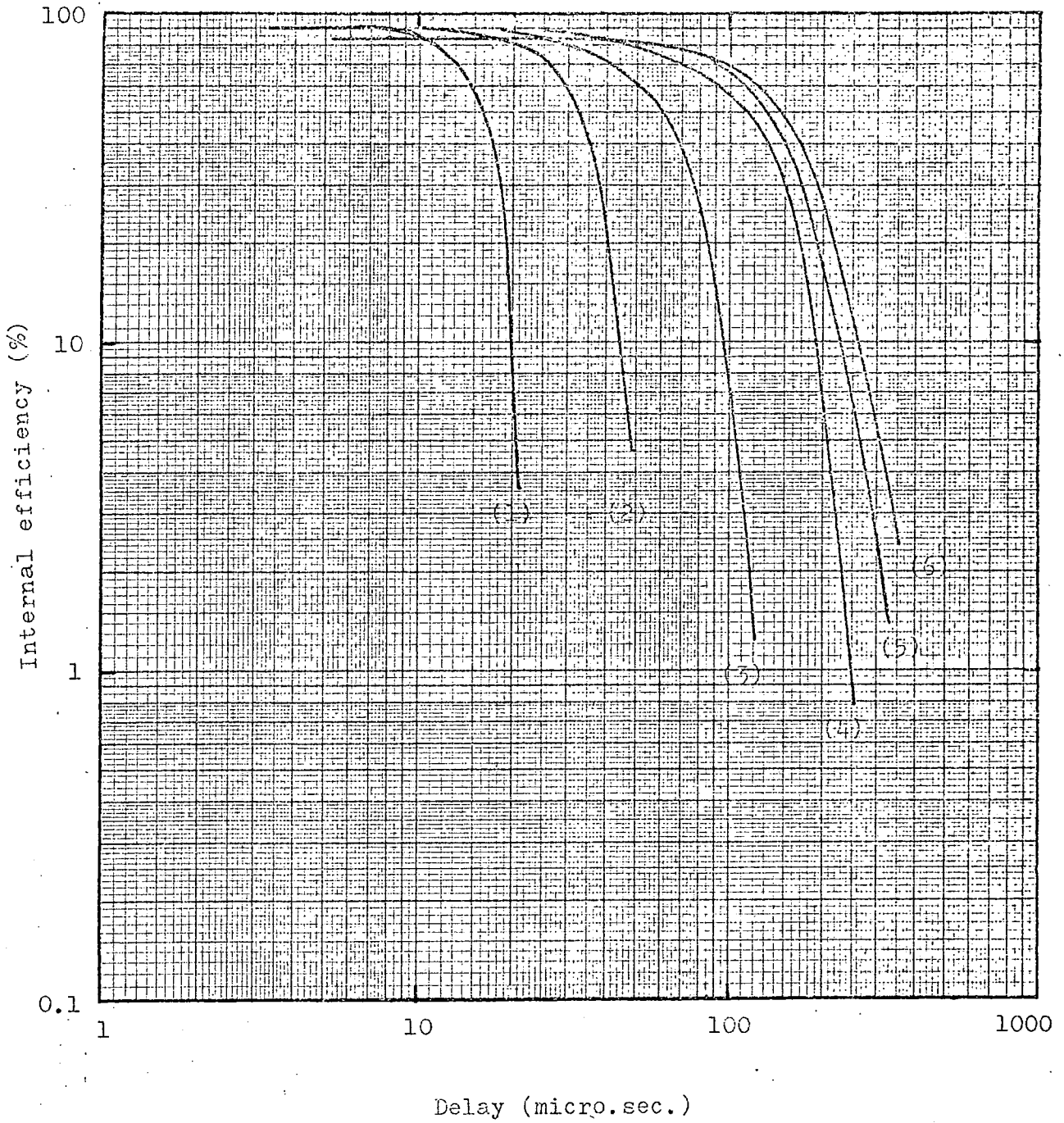

- (1)  $V = 10^5$  cm./sec.
- (2)  $V = 5 \times 10^4$  cm./sec.
- (3)  $V = 2.5 \times 10^4$  cm./sec.
- (4)  $V = 10^4$  cm./sec.
- (5)  $V = 4 \times 10^3$  cm./sec.
- (6)  $V = 0$  cm./sec.

figure 5.4



EFFICIENCY AS A FUNCTION OF DELAY

FOR DRIFT VELOCITIES IN THE SAME DIRECTION AS THE APPLIED FIELD

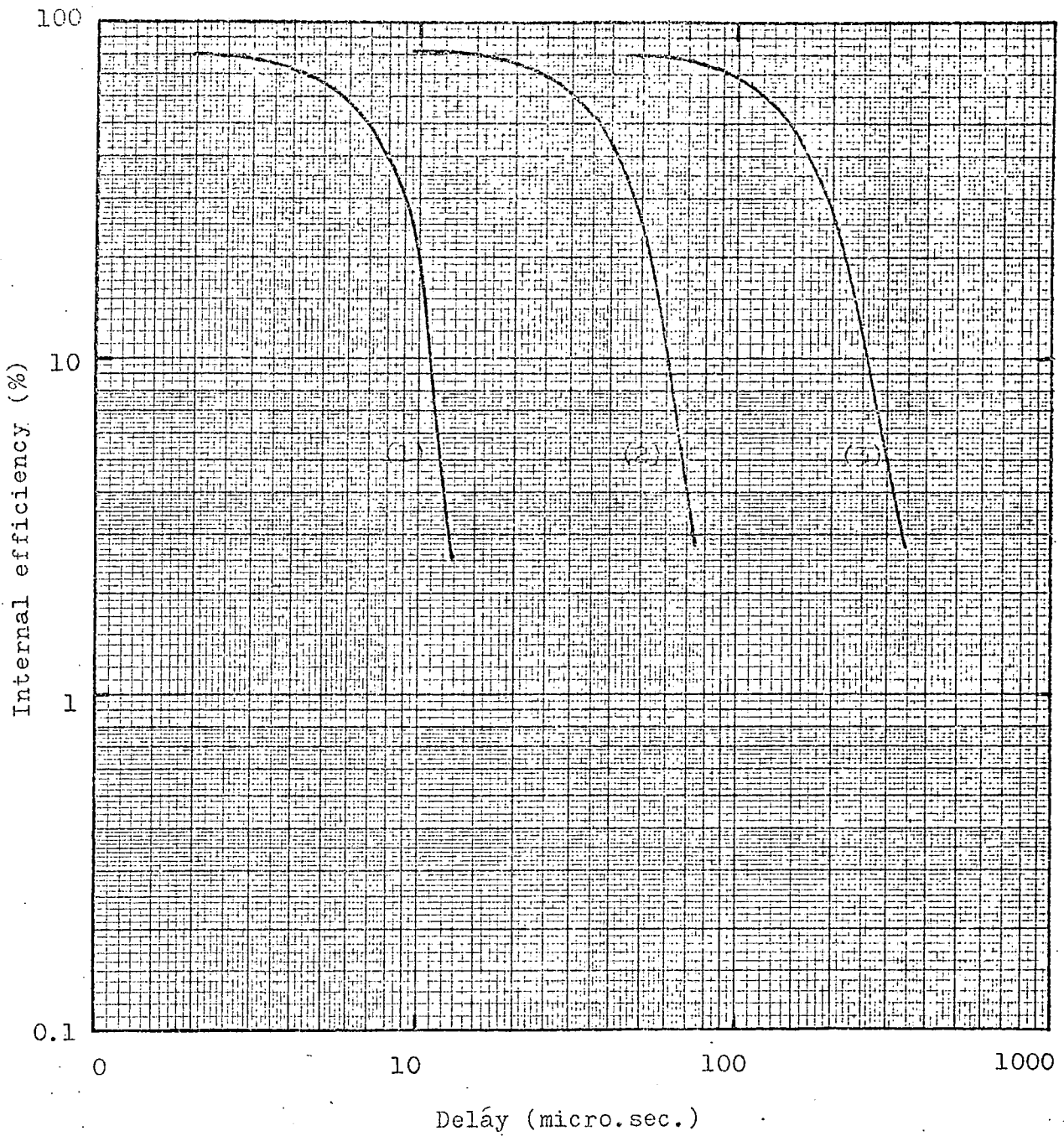

- (1)  $V = -10^5$  cm./sec.
- (2)  $V = -2.5 \times 10^4$  cm./sec.
- (3)  $V = -10^3$  cm./sec. &  $V = 0$  cm./sec.

figure 5.5

latter case they are swept towards the anode. For small drift velocities in opposition to the applied field there is a situation in which the efficiency at short delays can be slightly higher than the efficiency for zero clearing field because some electrons are swept into a more advantageous position by the clearing field. This effect can be seen in figure 5.4.

#### 5.6. POSITION OF THE TRACK IN THE FLASH TUBES.

The efficiency will depend on the position of the particle track in the flash tube. A particle passing through the centre of the tube will have a longer path in the gas in which to create ion pairs, and the electrons, on the average, will start off further from the walls and will therefore have a better chance of survival than electrons starting on a track nearer the wall.

The random walk method was used to obtain the efficiency as a function of the position of the track in the flash tube, for zero-drift velocity and for different delays. This is compared with experimental points obtained by drawing the best straight line through the muon tracks in flash tubes, and calculating the efficiency as a function of the distance of this line from the centre of the tube. The theoretical curves and the experimental points are shown in figure 5.6, and the agreement is seen to be quite good.

#### 5.7. DETERMINATION OF DRIFT VELOCITIES BUILT UP IN THE EXPERIMENTS.

In chapter 3 graphs were given of the experimental variation of efficiency with delay for different high voltage pulse lengths, at a fast repetition rate, and it was shown that clearing fields existed. Comparison of these graphs with the theoretical curves (figure 5.7) of efficiency as a function of delay for different drift velocities shows that the experimental curves correspond to clearing fields which decrease with increasing delay. This is to be expected since the efficiency, and therefore the rate of flashing decreases with increasing delay and hence a smaller clearing field is built up.

The drift velocities were found by comparing the experimental efficiency at a given delay with the graph of efficiency against drift velocity for that delay. (figure 5.8). The clearing field was then found from the data of Pack and Phelps (28) assuming that

EFFICIENCY AS A FUNCTION OF POSITION IN THE FLASH TUBE

(For formative distance of 0.75cm. and zero drift velocity)

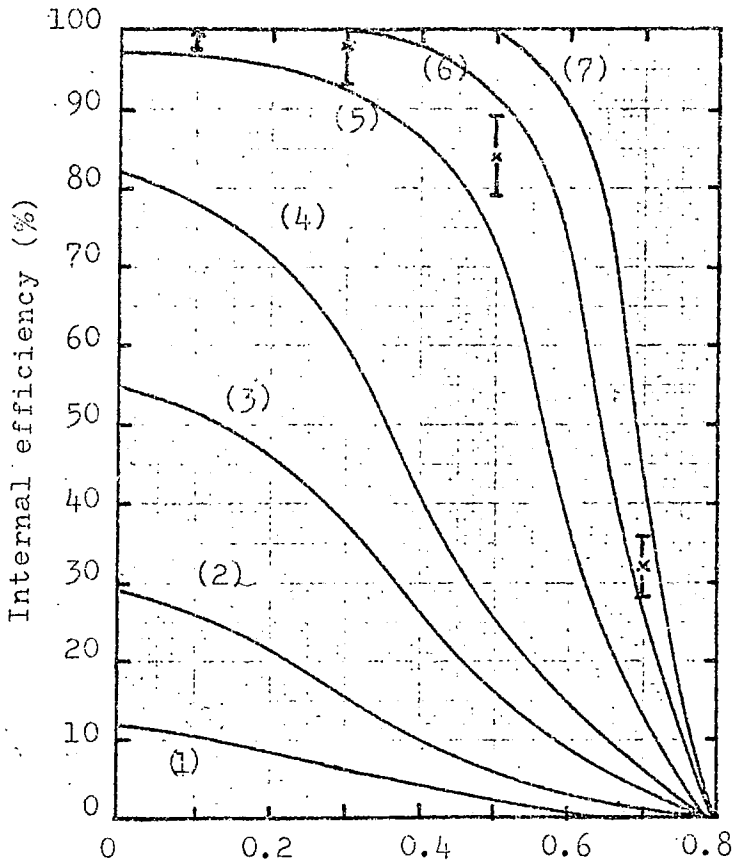

Distance of track from centre of flash tube (cm.)

$\times$  Experimental points for 50 micro.sec. delay.

- (1) Delay 300 micro.sec.
- (2) Delay 250 micro.sec.
- (3) Delay 200 micro.sec.
- (4) Delay 150 micro.sec.
- (5) Delay 100 micro.sec.
- (6) Delay 50 micro.sec.
- (7) Delay 10 micro.sec.

figure 5.6

EFFICIENCY AS A FUNCTION OF DELAY

COMPARISON OF EXPERIMENTAL AND THEORETICAL CURVES

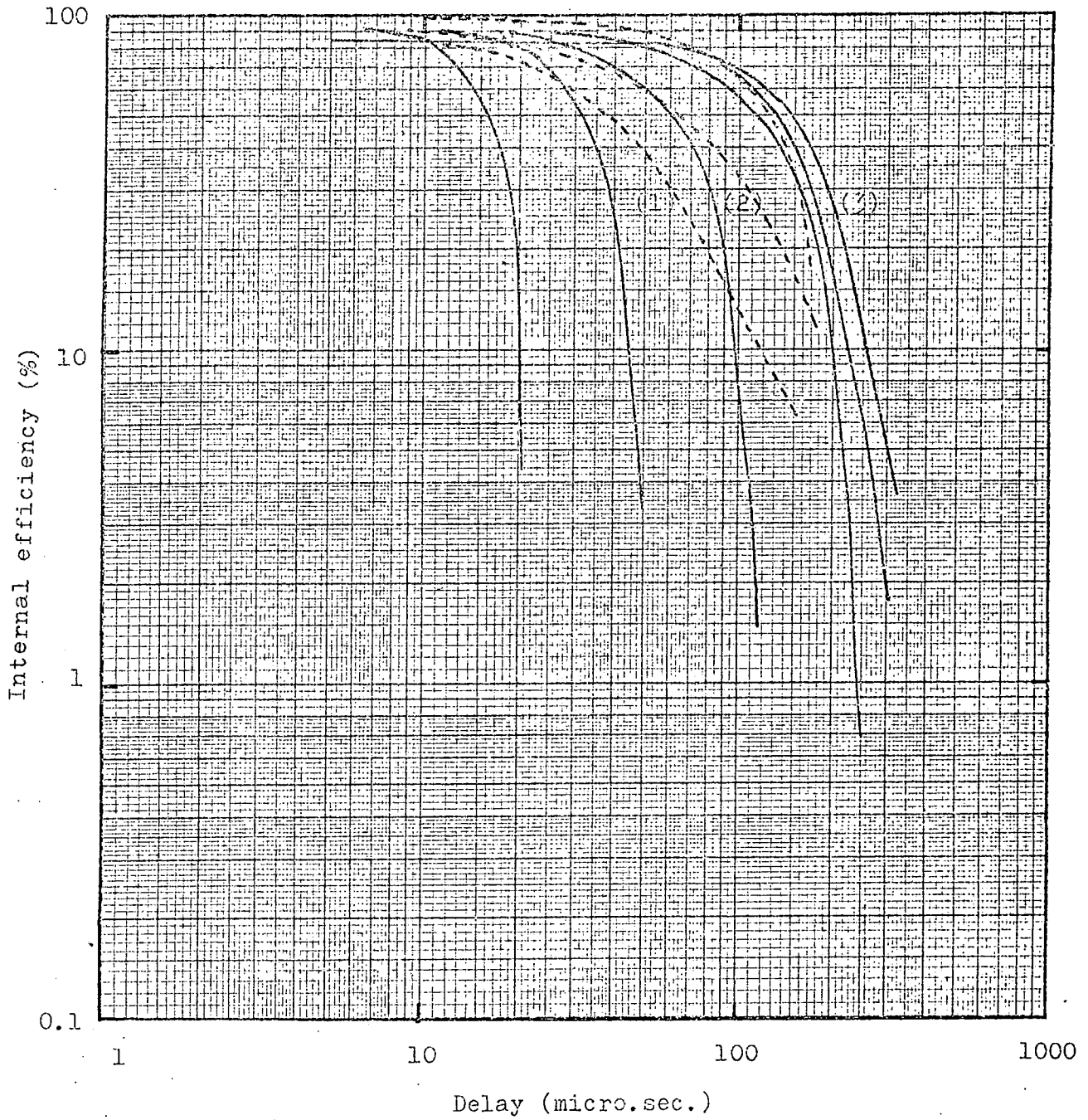

----- Experimental curves

(1) 40 micro.sec. R.C. high voltage pulse

(2) 4 micro.sec. R.C. high voltage pulse

(3) 0.4 micro.sec. R.C. high voltage pulse

—— Theoretical curves (as in figure 5.4)

figure 5.7

EFFICIENCY AS A FUNCTION OF DRIFT VELOCITY

FOR DIFFERENT DELAYS

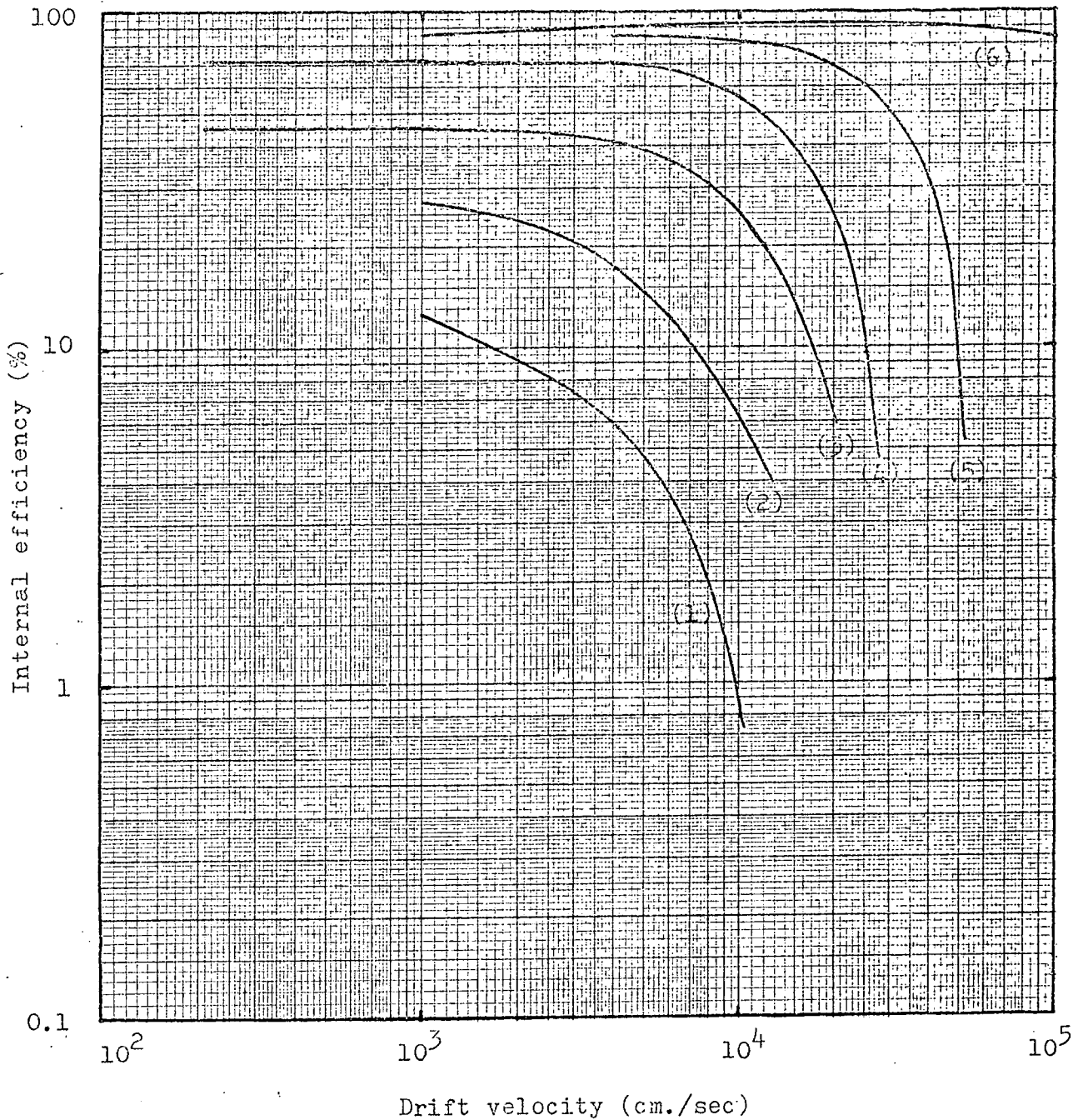

- (1) Delay = 250 micro.sec.
- (2) Delay = 200 micro.sec.
- (3) Delay = 150 micro.sec.
- (4) Delay = 100 micro.sec.
- (5) Delay = 50 micro.sec.
- (6) Delay = 10 micro.sec.

figure 5.8

the relationship between field and drift velocity for the neon/helium mixture does not differ significantly from that for pure neon. Figure 5.9 shows the variation of clearing field with efficiency for different high voltage pulse lengths.

In the experiment described in chapter 3 where an external field of 8.5 V/cm was applied to the flash tubes, a reduction in efficiency at 50 micro sec. delay from 76% to 67% was observed. Comparison with the theory gives an effective clearing field of 0.1 V/cm compared with the value of 0.5 V/cm found by a very approximate method in chapter 6.

### 5.8. DECAY OF THE CLEARING FIELDS

It has been shown in a previous chapter that the discharge in a flash tube is self quenching when the field created by charge separation backs off the applied field to such an extent that the discharge can no longer be sustained. When the high voltage pulse is removed the back field will decay according to the equation:-

$$V = V_0 \exp(-t/\tau)$$

where :-

$$V = \text{field at time } t$$

$$V_0 = \text{field at } t = 0$$

$$\tau = \text{decay constant.}$$

Assuming that the initial back field is equal and opposite to the applied field of 4 KV/cm, and considering a repetition rate of 1 flash/minute/tube, a decay constant of 6.0 sec. is required for the field to decay to 0.2 V/cm, a typical clearing field obtained with the repetition rate of 1 in 60 seconds. The value of  $\tau$  obtained in chapter 3, from the resistance and capacitance of a flash tube was 2.7 sec. The difference can be explained in terms of variations in the surface resistance of glass which could vary by as much as a factor 2 from tube to tube.

The magnitude of the clearing field is proportional to the amount of charge deposited on the flash tube walls. This is given by:

$$\frac{dn}{dt} = S - \frac{n}{\tau}$$

where :-

$$n = \text{number of electrons}$$

$$S = \text{rate of deposition charge}$$

$$\tau = \text{decay constant}$$

CLEARING FIELD AS A FUNCTION OF EFFICIENCY

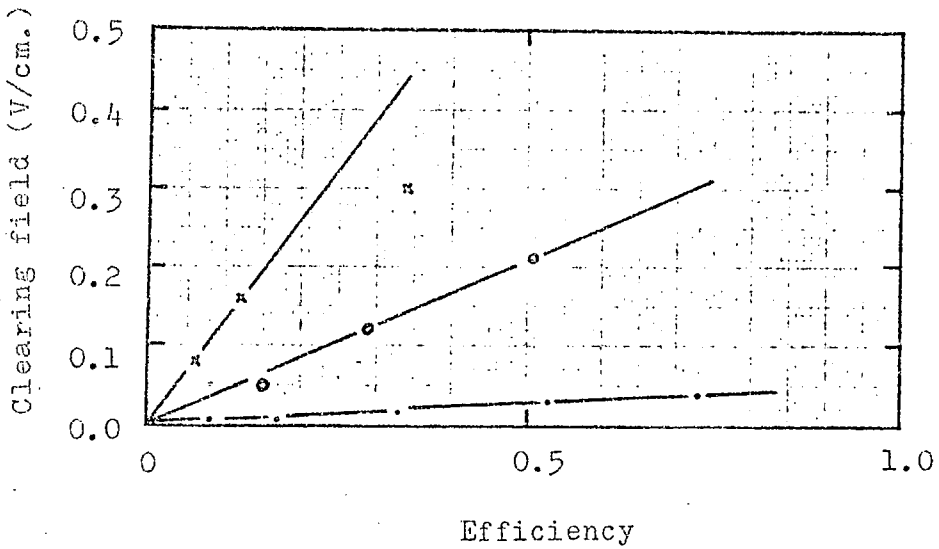

- x 26.8 micro.sec.R.C. high voltage pulse
- o 40.0 micro.sec.R.C. high voltage pulse
- 0.4 micro.sec.R.C. high voltage pulse

(Different sets of points are not necessarily for the same repetition rate.)

figure 5.9

CLEARING FIELD/EFFICIENCY AS A FUNCTION OF HIGH VOLTAGE PULSE LENGTH

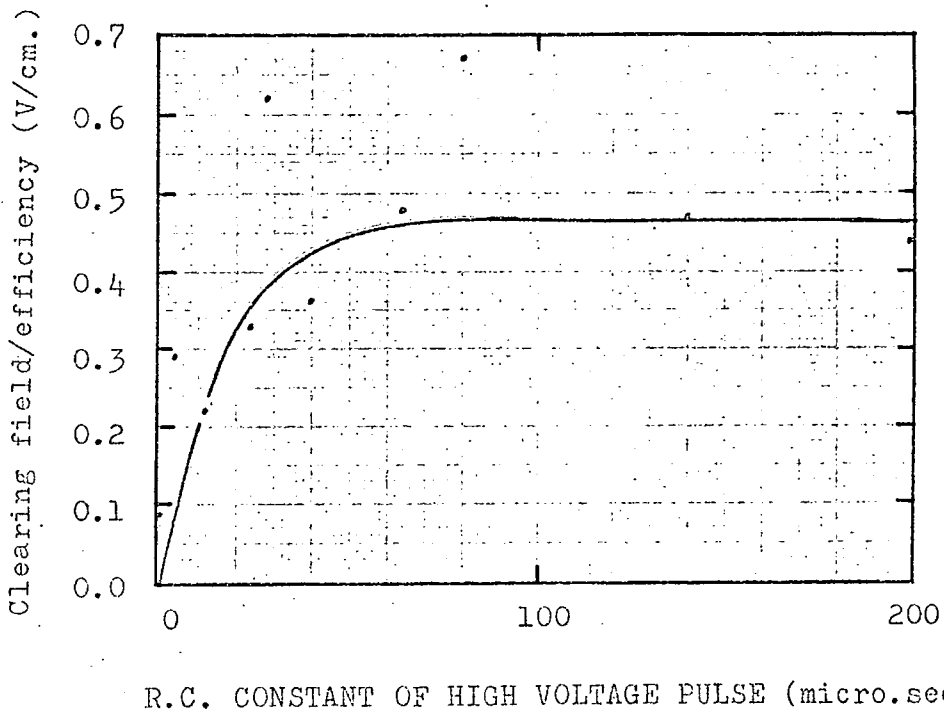

R.C. CONSTANT OF HIGH VOLTAGE PULSE (micro.sec.)

figure 5.10

Integrating gives:-

$$n = S\tau(1 - \exp(-t/\tau))$$

Thus  $V = KS\tau(1 - \exp(-t/\tau))$

where  $V =$  clearing field  
 $K =$  is a constant

For a rate of flashing of 1/60 seconds,  $\exp(-t/\tau)$  tends to zero, so

$$V \approx KS\tau$$

Now  $S$ , the rate of deposition of charge on the walls of the flash tube is proportional to the rate of flashing, and to the amount of charge deposited per flash, which depends on the high voltage pulse length.

$$\frac{dn}{dt} \propto V$$

since the drift velocity of positive ions is approximately proportional to the field. (Von Engel (33))

$$\frac{dn}{dt} \propto V_0 \exp(-t/RC)$$

where  $RC =$  decay constant of the high voltage pulse.

$$\int_0^N dn \propto \int_0^{\infty} V_0 \exp(-t/RC) dt$$

$$N \propto -V_0 \left[ \exp(-t/RC) RC \right]_0^{\infty}$$

$$N \propto V_0 RC$$

Thus the amount of charge deposited, and hence the clearing field, is proportional to the  $RC$  constant of the high voltage pulse.

$$V \propto RC V_0 \eta (\tau/t)(1 - \exp(-t/\tau))$$

where  $V =$  clearing field  
 $RC =$  decay constant of the high voltage pulse  
 $V_0 =$  field immediately after a flash  
 $\eta =$  efficiency  
 $\tau =$  decay constant of the charge  
 $t =$  interval between flashes.



A graph of clearing field divided by efficiency against RC is shown in figure 5.10. The reason why this is not a straight line is that there is not an infinite supply of positive ions to deposit on the flash tube walls, and all the available charge is swept out of the gas by a high voltage pulse a few tens of micro.seconds long.

Figure 5.9 shows the variation of clearing field with efficiency and it can be seen that for a fixed high voltage pulse length a straight line graph is obtained.

### 5.9. CONCLUSION.

The diffusion equation for electrons in a flash tube can be solved analytically only if no drift term is present. The random walk method of solution is a very powerful one. In the limit where the number of electrons considered tends to infinity, the solution tends to the analytical solution. The method has the great advantage of simplicity, and any process which the electrons undergo can be put into it. The formative distance of the discharge, and drift velocities of electrons have been included in the theory in this chapter, and attachment of electrons to impurity molecules, creation of electrons from metastable atoms, and other processes for creation or removal of electrons could just as easily be included provided the probability of these processes occurring was known. The accuracy of the solution is limited by the number of electrons considered, and in the present work this was severely limited by the amount of time available. However, sufficient statistics were obtained to show that experimental results can be explained on the basis of the diffusion and drift theory, and to indicate that a more detailed and accurate model of the flash tube could be evolved by this method.

The decay constant of the clearing fields has been calculated from the values to which they have decayed in the interval between flashes, and the value found to agree reasonably well with that found in chapter 3 from measurements of resistivity and capacitance of flash tubes. Relationships between clearing fields and efficiency, repetition rate, and length of the high voltage pulse, have been found.

## CHAPTER 6.

### DISCUSSION.

The main object of this work has been to investigate the clearing fields which have been found to reduce the efficiency of flash tubes when they are operated at high repetition rates, and a study has also been made of the discharge mechanism and its relationship to the clearing fields. In this chapter the experimental results are discussed together with the processes which they suggest occur in flash tubes, and an attempt is made to explain some of the anomalous experimental results. Some suggestions are made for future work on flash tubes.

#### 6.2. PRODUCTION OF ELECTRONS IN FLASH TUBES.

When an ionising particle passes through a flash tube it produces a primary ionisation of 12 ion pairs/cm/atmosphere pressure. In the process of thermalisation a total ionisation of 33.6 ion pairs/cm/atmosphere is achieved. According to Heyn (38) the thermalisation process is complete in 500 n.sec., and Lloyd (22) quotes a time of 1 micro.sec. Since the minimum delay used in the experiments in chapter 3 was 400 n.sec., a value of ionisation of 33.6 may not be valid in this case, but a value between 12 and 33.6 should be used. A primary electron will produce secondary electrons fairly close together in its vicinity, and if the high voltage pulse is applied before these have had time to diffuse apart a single avalanche may be started by a cluster of electrons instead of by a single electron. It was shown in chapter 5 by comparison of experimental values of efficiency with theoretical predictions, that the effective formative distance, i.e. the distance needed for an electron to avalanche to the critical size, appeared to be much less for short delays (about 10 micro sec.) than the value of 0.75 cm. obtained for longer delays. This could be explained by postulating that a cluster of electrons will avalanche to the critical size in a shorter distance than a single electron.

During the delay between the passage of the particle through the gas and the application of the high voltage pulse, the electrons will undergo a diffusion process. Some of them will reach the walls of the

flash tube, and it has been assumed that these will stick to the glass and be lost from the gas. Lloyd quotes Massey and Burnhop (39), but these authors do not mention specifically the attachment of electrons to glass. Von Hippel, (40) writing about electrons in insulators, states that electrons which are travelling slowly enough to transfer their energy to a heavy particle in the insulator will become trapped. Glass has a very irregular surface on a molecular scale, and there will be many potential wells into which an electron could "fall".

Electrons may be lost from the gas by attachment to impurity molecules such as water and oxygen if these are present. The cross sections for attachment vary with electron energy, and are of the order of  $10^{-18}$  cm<sup>2</sup>. at electron energies of about 6 eV (Buchel 'Rikova (19)). In the ordinary flash tubes used, the concentrations of water and oxygen were negligible, but in tubes manufactured with high water content the effect was clearly seen from the graphs of efficiency as a function of delay. The efficiency at a given delay was much lower than for ordinary tubes. Other substances, notably halogen compounds, have the same effect, and could be used to deliberately reduce the sensitive time in tubes which were to be operated at high repetition rates. Water is not a good substance to use in this connection since it also has the effect of reducing the brightness of the flash.

Further electrons may be created by the decay of metastable atoms which result from the ionising particle. Lloyd (22) quotes from the work of Jesse and Sadauskis (41) a number of metastables 0.46 times the number of ion pairs, and a rate of 1/180 micro sec. for the decay of metastables with the production of an electron. Using these figures, calculation shows that the number of electrons contributed in this way during the delay time is negligible.

If electric fields are present they will sweep electrons to the walls of the tube. This will be discussed in a later section.

### 6.3. THE DISCHARGE.

When a high voltage pulse is applied the probability of a discharge depends on the number and position of the electrons in the gas. An electron requires a finite distance, depending on the magnitude and rise time of the applied field, in which to avalanche to the critical size, and if it is within this distance of the anode when the high voltage pulse is applied, it will not start a discharge. The probability of a given electron initiating a discharge may, for short delays,

increase slightly with time, since it may start off within the formative distance and diffuse or drift out of it. This has been shown in chapter 5. However, for long delays, loss by diffusion to the walls of the tube will dominate.

If the first avalanche does not reach the critical size the electron density in the tube may still become high enough for breakdown to occur, by the Townsend mechanism. Electrons may be liberated from the glass when positive ions or photons from the first avalanche strike it, and photoionisation of neon atoms may occur. Electrons so produced will also avalanche. The Townsend process takes longer than streamer breakdown, and therefore requires a longer high voltage pulse, but it will take place at lower fields. This indicates that the probability of flashing by a Townsend mechanism might increase with pulse length, so that the decrease observed for fast repetition rates is opposed by this mechanism.

In fact, except in the plateau region, the efficiency does increase with pulse length, as shown in figure 4.1. The minimum voltage at which breakdown will occur increases with decreasing pulse length as the streamer mechanism takes over gradually from the Townsend.

It was seen in chapter 4 that the discharge is propagated down the tube with an approximately constant velocity of  $0.24 \text{ cm/n.sec.}$  and that the most probable method to fit in with this velocity is that breakdown in different positions along the tube results from emission of electrons by photons from the initial and successive avalanches.

From the light pulse measurements in chapter 4, (figure 4.7) it is seen that the flash in 100 cm long tubes lasts for about 600 n.sec. and that this is independent of the length of time for which the high voltage field is applied. This indicates that the discharge is self quenching when the field due to charge separation backs off the applied field to such an extent that it can no longer be sustained. Figure 6.1. shows the <sup>probable</sup> electron and ion concentrations in the tube during the discharge, and the corresponding field, which at any time is the sum of the applied field and the back field created by charge separation. The former is approximately constant during the time considered, (600 n.sec). The latter is a function of position in the tube as well as of time.

ELECTRON AND ION DISTRIBUTIONS AND FIELD IN FLASH TUBE  
DURING THE HIGH VOLTAGE PULSE

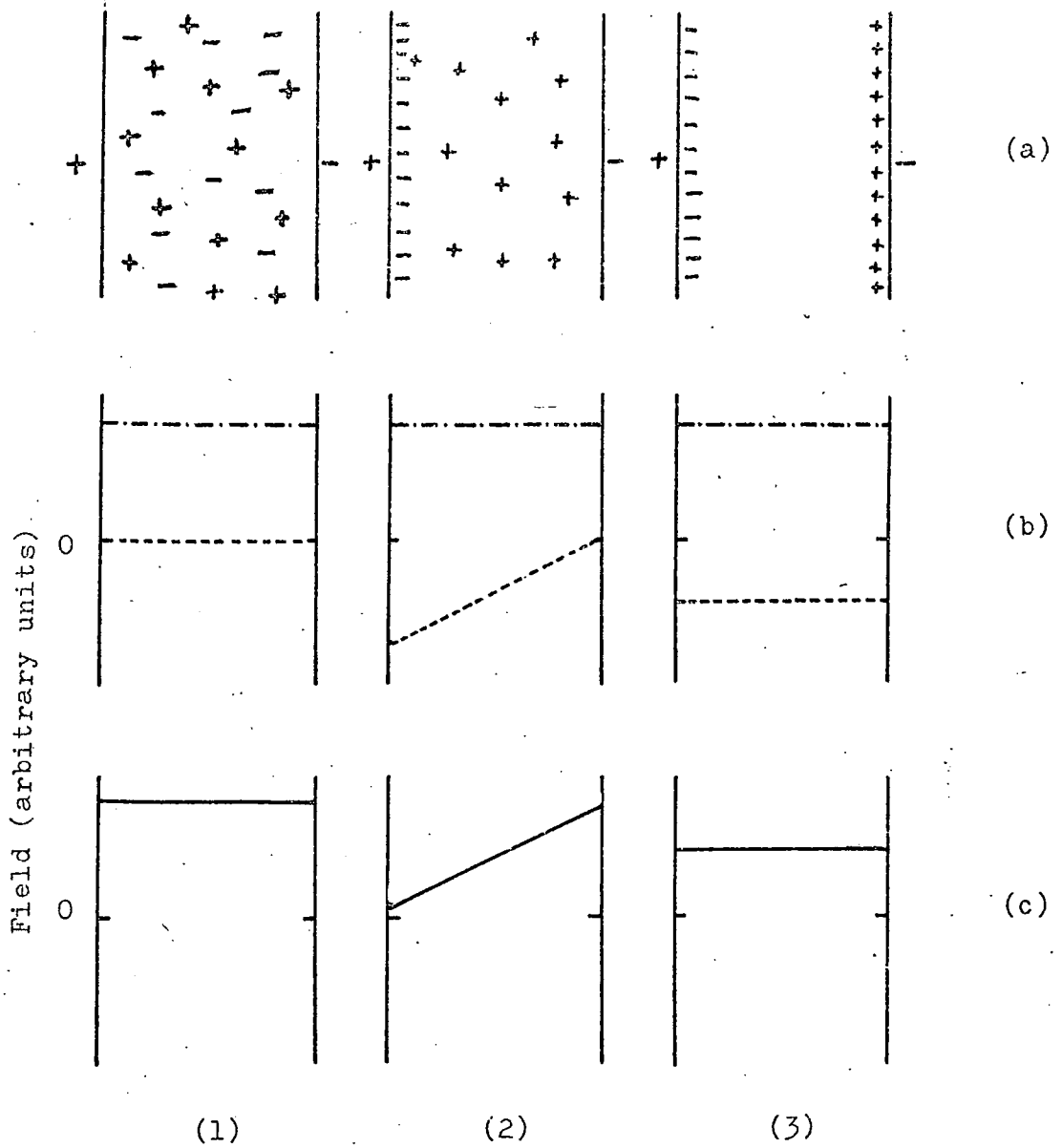

- (a) Electron and ion distributions
- (b) Fields due to applied pulse and charge separation
  - applied pulse
  - charge separation
- (c) Net field
- (1) No charge separation
- (2) Electrons on anode
- (3) Complete charge separation

figure 6.1

#### 6.4. CLEARING FIELDS

It is estimated from electron drift velocities given by Pack and Phelps (28) that for a 4 KV/cm field electrons will be removed from the tube in about 200 n.sec., and hence most of the electrons in the discharge will be deposited on the glass.

The positive ions however, move much more slowly, and the number of these deposited on the glass will depend on the potential seen by them during and after the discharge, and on the duration of the high voltage pulse, as well as on the number of ion pairs created which was shown in chapter 4 to be proportional to the square of the applied field, and to be of the order of  $10^{12}$ .

The field seen by the positive ions will decrease due to the decay of the high voltage pulse, and also due to the back field created by charge separation. When the applied field has decayed to a value equal and opposite to the back field, the positive ions will stop drifting to the anode wall of the flash tube, and as the high voltage pulse decays further, those which have not already reached the wall will drift back towards the cathode side where they will neutralize some of the electrons which have been deposited there.

When the applied field has been removed altogether, the field in the tube will depend on the number of positive ions which have been deposited on the walls, and it is this field which is thought to be responsible for the reduction of efficiency at long delays when high repetition rates are used.

It would be expected that this field will decay by conduction of electrons over the glass, and this is supported by the fact that the efficiency of flash tubes operated at high repetition rates increases with the conductivity of the glass used, and can be made independent of repetition rate, up to 1/10 sec/tube, by the addition of water which increases the surface conductivity of the glass. If the effect were due to polarization, the surface conductivity would be expected to have no effect. It is possible that polarization does occur, and may be responsible for the long term clearing fields.

Pickersgill (25) suggested that the reduction in efficiency might be due to fields, caused by charge separation or polarization of the glass, backing off the pulsed field next time it is applied. This is disproved by the fact that the brightness of the flash does not decrease,

as it does when lower applied fields are used and in any case, if the clearing fields were sufficient to back off the applied field to such an extent as to reduce the efficiency, all the electrons would certainly be swept out of the tube during the delay time.

The clearing field effect was shown in chapter 3 to increase with increasing length of the high voltage pulse until a maximum was reached at an RC constant of about 40 micro sec. This is consistent with the charge separation model since a maximum effect would obviously occur when all the positive ions were swept out of the gas and calculations from drift velocities given by Pack and Phelps (28) show that for a 4 KV/cm pulse with a decay constant of 80 micro sec., all the positive ions should be removed from the tube.

However, this fact is not inconsistent with the polarization model. A certain length of time is required for an ion in a substance to become polarized, and it may be that once a critical length of time is attained the probability of polarization shows no further increase.

It is not clear why the clearing field effect is independent of applied voltage. The efficiency at delays from 400 n.sec to 300 micro sec. does not vary with increasing field above a critical voltage either with or without clearing fields, although the brightness does increase, as shown in chapter 4, indicating that more photons, and hence more electrons take part in the discharge. The product of Q, the number of electrons present at the beginning of the high voltage pulse, and F, the probability of an electron initiating a discharge must therefore be independent of the field. For no clearing field, Q is obviously independent of the high voltage pulse, and it must be assumed that F, which is governed by the formative distance must also be independent of applied voltage in the plateau region.

According to Fischer and Zorn (32) an electron should avalanche to the critical size faster the higher the field, but the velocity also increases with increasing field.

$$\frac{\partial n}{\partial t} = f(E)$$

where  $\frac{\partial n}{\partial t}$  = rate of build up of charge  
E = field

and  $\frac{\partial x}{\partial t}$  = constant  $\times$  E, approximately.

If  $f(E)$  is approximately linear over the range considered; about 2 to 7 KV/cm,  $\partial n/\partial x$  will be approximately constant over this range, i.e. the increase of avalanche size for a given distance, and hence the formative distance, will be independent of field.

When clearing fields are built up, their magnitude would be expected to depend on the number of ions in the discharge, and on the height and length of the high voltage pulse. Considering the flash tube as a capacitance,  $C$ , the relationship between the voltage  $V$  across it, and  $Q$ , the amount of charge involved is given by:-

$$Q = C.V$$

so that the clearing field will be proportional to the amount of charge deposited on the glass. Since the number of ions in the discharge increases and the field seen by the positive ions after the discharge would be expected to increase, or at least not to decrease with increasing field, it is difficult to see why the clearing field effect is independent of the applied voltage. However, the clearing field depends on the rate of flashing, and as the former increases the latter obviously decreases. Thus it appears that an increased applied field causes an increased clearing field effect which in turn reduces the efficiency and hence the clearing field, so that an equilibrium value of efficiency is attained which is independent of the applied field.

When the pulsed field is removed, back sparking may occur if the field due to charge separation is high enough to cause breakdown and electrons are present in the tube, either remaining from the discharge, or produced from the decay of a metastable atom or by a second cosmic ray. Back discharging will cause localised reductions of the clearing fields, and may help to explain the fact that these are independent of applied voltage. If the field inside the tube is reduced to a value where discharges can no longer occur, this value should be constant, so that the resultant clearing field would be independent of the initial field. According to this model, however, the field should not depend on the duration of the applied field either.

#### 6.5. THE LONG TERM CLEARING FIELDS.

The long term effect does ~~not~~ depend on applied field, as shown in chapter 3, and this indicates that it is dependent on a different process from the short term effect.

It would be expected that a minimum amount of energy would be necessary to cause polarization in glass, and it may be that this minimum energy is achieved with the fields of about 6 KV/cm at which the



long term clearing field effect becomes apparent.

Alternatively, the long term effect could be due to electrons trapped in the glass as distinct from charge on the surface which is relatively free to move. Surface conduction of electrons by the glass of which flash tubes are made is almost certainly due to the layer of water present on the surface. The mobility of electrons actually in glass ( $5 \times 10^{-5} \text{ cm}^2 \text{ sec}^{-1} \text{ volts}^{-1}$ ) (43) gives a resistivity much higher than the measured value, even in a supposedly dry situation. It is well known that glass, especially if not very clean, acquires a thin layer of water on its surface which requires temperatures of hundreds of degrees centigrade to remove completely. The more energetic electrons in the discharge might be able to penetrate this layer of water and become trapped in the glass. Here they would have a lower mobility than those in the water layer, and would consequently move much more slowly, and might give rise to long term fields. This mechanism would be dependent on the applied voltage since electrons would require a minimum energy to penetrate the water layer, and also because the number of electrons involved increases with applied field.

The fact mentioned in chapter 3, that when tubes which show the long term clearing field effect are operated with a high voltage pulse of the opposite polarity they give an increased efficiency, shows that the effect is cancelled out by a field (presumably short term) of the opposite polarity. This means that the long term and short term effects are of the same polarity, which argues against polarization, since this would give a field of the opposite polarity to one caused by charge separation.

Whether the effect is due to trapping or polarization, it should decrease with increasing temperature since thermal motion will increase both the probability of depolarization and of release of electrons from traps. In the experiments in chapter 3 the temperature was monitored, and never varied by more than a few degrees centigrade, nor was it possible, in the present situation, to vary the temperature by more than this amount in order to assess its effect. However, certain rather large fluctuations in efficiency were encountered, for example in figure 3.10, and it may be that these could be explained in terms of temperature variations.

## 6.6. EXTERNAL CLEARING FIELDS.

When external clearing fields were applied to the flash tube arrays, the reduction in efficiency did not agree with the value calculated from the data of Pack and Phelps (28) for the relationship between field and drift velocity. The reason for the disagreement could be either an incorrect assumption about the drift velocity, or an incorrect value of clearing field.

The work of Pack and Phelps was done on pure neon, and the gas used in the flash tubes was a mixture of neon and helium. The drift velocity could therefore be in error.

In calculating the clearing field across the gas, it is only an approximation to neglect the effect of the glass. If one considers the application of pulsed and D.C. fields to a flash tube, the system can be reduced to 3 capacitors in series, (figure 3.11) each with a leakage resistance.

For a pulsed field, assuming the capacitive impedance to be small compared with the resistive component, the fields across the gas and glass will be proportional to the reciprocal of their dielectric constants; 1 and 7.5 respectively. For a pulsed field of 4 KV/cm across the electrodes, the fields appearing across the glass, which is 1 mm thick, and the gas, 1.6 cm. at the centre of the tube, would be 0.59 KV/cm and 4.4 KV/cm. Thus the field across the gas is not very different from the value calculated on the assumption that the effect of the glass can be ignored.

For a D.C. field however, the fields appearing across the glass and gas will be totally dependent upon the resistive component of the impedance. The leakage resistance of the gas is due to conduction round the glass, and that of the glass, to volume conduction. Surface and volume resistivity were shown in chapter 3 to be  $5 \times 10^{13}$  ohms/square and  $5.3 \times 10^{13}$  ohms cm. respectively. Assuming that the area of contact between the glass and the electrodes is small, say 0.1 mm times the tube length, the fields across the glass and gas are calculated to be 72 V/cm and 0.5 V/cm for an 8.5 V/cm field across the electrodes. Thus for D.C. fields, the field in the gas is probably much less than the value calculated without taking the glass into account. In practice the area of contact between the glass and the electrodes may be much smaller than the value used here, so that the effect described may be even more accentuated.

### 6.7 ATTEMPTS TO OVERCOME THE CLEARING FIELD EFFECT

Of the methods tried to overcome the clearing field effect, the use of a bipolar ringing pulse seems to be the most satisfactory. Attempts to reduce the effect by increasing the surface conductivity of the glass lead to anomalous and unreliable results. The tubes coated with stannic oxide before formation did not flash at all, possibly because the conducting layer reduced the effective field inside the tube to such an extent that discharge was not possible. Other tubes which had been coated after manufacture, showed a very high rate of spurious flashing. This could be explained if the surface was made uneven by the layer of stannic oxide. The coating layer in the tubes mentioned above would be smoothed out when the tubes were heated during manufacture. Spurious flashing is thought to be due to minute dust particles or unevennesses on the glass surface. Very high localised fields will exist in the region of these particles, and field emission could occur. Hampson (26), working with tubes which had been chemically cleaned, found that the rate of spurious flashing was negligible, while in the M.A.R.S. experiment where the tubes are not chemically cleaned, a very high spurious rate is encountered. Malter (34) reports a high rate of spurious counts in Geiger tubes, which he associates with fine particles of insulating materials such as  $MgO$ ,  $Al_2O_3$  and  $SiO_2$  on the cathode. When the tubes were mechanically or electrically cleaned, the spurious counts ceased.

The tubes which contained liquid water also showed a high spurious rate. Very high fields will be developed across the gas/water boundary due to the large difference in dielectric constant, about 80 for water and 1 for neon, and field emission could occur.

The very high efficiency of these tubes could also be explained by these high fields. Any electron accelerated in such a field would have a high probability of starting a discharge.

The tubes which contained the least amount of water vapour (0.04 mm.Hg pressure) exhibited an increased efficiency when operated at a high repetition rate. This might be due to clearing fields too small to have a noticeable effect on the efficiency, changing the mean energy of the electrons, and hence the attachment coefficient. Unfortunately no data seems to be available for electron energies below 5 eV, which is well above the estimated energy of thermal electrons

(0.025 eV). It seems unlikely that the water molecules become 'saturated' with electrons when high repetition rates are employed, since the number of water molecules involved is of the order of  $10^{18}$ , and the number of electrons/discharge is seven orders of magnitude less than this. These tubes showed an increase in efficiency, even at slow repetition rates, as a function of age. It is possible that the water became absorbed by the glass with time but that in the tubes which contained more water vapour, the effect was not noticeable. When high repetition rates were used, the glass surface may have been so modified by the discharge that water was temporarily absorbed by it.

The presence of water vapour caused a marked reduction in the brightness of the discharge. This is probably due partly to a reduction in the effective field by the increased conductivity of the glass, (the stannic oxide coated tubes also showed this effect) and partly to the absorption of ultraviolet photons by the water molecules, reducing the growth of the discharge. It was seen in figure 4.7. that the duration of the discharge in high water content tubes was short compared with the duration in conventional tubes. If the water molecules absorbed most of the ultraviolet photons and prevented their spreading the discharge down the tube, the duration of the light output would correspond simply to the length of time taken for the initial discharge to develop and die away.

It must be noted that no very accurate quantitative conclusions can be drawn from these special tubes because of the large number of uncertainties involved in their manufacture. For example, the water used in one set of tubes (B) was left exposed to the air for some time, and so may have absorbed an unknown quantity of oxygen, and the method of introducing water into the tubes was such that, due to absorption by the apparatus, the concentration of water vapour could not be controlled accurately, and was not even constant for all the tubes produced in one batch.

From the results it appears that if flash tubes can be manufactured with sufficient water vapour in them for any effects of high repetition rates and of age to be negligible, and yet not to contain liquid water, they may be able to be used for machine experiments where short sensitive time and absence of clearing field effects are required, but the faintness of the discharge could be a serious disadvantage.

The use of a bipolar ringing pulse does not impair the brightness of the flash, and does not show clearing field effects for rates as high as 1/10sec./tube. The higher the ringing frequency the shorter will be the distances travelled by the electrons and ions, and hence the fewer will be deposited on the glass. It may prove difficult to apply such a pulse to large flash tube arrays because of their large capacitance, but the difficulty should not be insurmountable if the arrays are operated in transmission line mode.

#### 6.8. RECOVERY TIME.

The factor which now limits the use of flash tubes at high repetition rates is the long recovery time. The reason for this phenomenon is not fully understood. The same effect has been observed in sealed spark chambers (35), but the recovery time of conventional spark chambers is of the order of only milliseconds. This indicates that the effect is due to the presence of a layer of glass between the gas and the electrodes, and may be related to the thin film field emission reported by Malter (36). Certain substances, for example  $Al_2O_3$  and  $SiO_2$  were found to emit electrons for some time after bombardment by electrons. It is quite conceivable that these or similar substances present in the glass will show the same effect, producing electrons which will cause reignition of a tube if it is pulsed again soon after a flash.

The decay of metastable atoms produced during the discharge could also give electrons which would cause the tube to flash on the second pulse, but this mechanism would also cause reignition in conventional spark chambers.

#### 6.9. CONCLUSION.

In this thesis the discharge mechanism in flash tubes has been studied, and shown to be, in most cases, a combination of streamer and Townsend breakdown. The probability of a discharge occurring depends on the characteristics of the applied high voltage pulse, and on the number and position of the electrons present in the tube when this pulse is applied. The discharge is propagated along the tube and with an approximately constant velocity, probably by a process of photoemission from the tube walls. It has been shown that the discharge is self quenching when the back field caused by charge separation reduces the net field to a value such that the discharge can no longer be sustained, and may be quenched in one part of the tube before another has ignited.

When flash tubes are operated at high repetition rates, a reduction in efficiency is encountered, which can be explained in terms of back fields caused by charge separation. The effect has been shown to depend on the duration of the high voltage pulse and on the resistivity of the glass, and it is therefore thought that the magnitude of the fields is governed by the amount of positive charge deposited on the glass during the high voltage pulse, and that the fields decay by conduction of electrons through a layer of water on the glass surface to neutralise the positive ions deposited on the other side of the tube. A long term clearing field effect has also been detected, and this is thought to be caused by electrons trapped in the glass rather than simply deposited on the surface.

A random walk method has been developed to compute the number of electrons present in the flash tube, and hence the efficiency, as a function of time. The method takes into account diffusion of electrons to the walls, drift due to clearing fields, and the formative distance of the discharge. From the results, the values of the clearing fields built up during the experiments have been estimated.

Reduction of the surface resistivity by increasing the water content of flash tubes has been shown to reduce the clearing field effect below a detectable level for repetition rates of up to 1/10 sec./tube.

A more satisfactory and reliable way of overcoming the clearing field effect is the use of a bipolar ringing pulse, and this method, unlike the addition of water, does not reduce the brightness of the flash.

If flash tubes are to be used at high repetition rates, the sensitive time must be short. This is reduced by the addition of water, or some other substance, notably halogen compounds, which have a high affinity for free electrons.

The long recovery time, thought to be due to emission of electrons by the glass after bombardment by electrons during the discharge, now limits the use of flash tubes at high repetition rates.

#### 6.10. FURTHER EXPERIMENTS.

Further experiments which are suggested by this work are a closer examination of the long term clearing field effect, whose cause and characteristics are still not fully understood, and an investigation into methods of reducing the sensitive time and the recovery time of flash tubes to enable them to be used at the very high repetition rates (about 1/millisecond.) which are necessary for machine experiments if several events per burst of particles are to be recorded.

The long term effect should be measured in high water content tubes, (if the effect is due to trapping, fewer electrons should be able to penetrate the thicker layer of water) and when a bipolar ringing pulse is used. The effect of temperature on the long term clearing field effect should be investigated.

These two methods of reducing the clearing field effect should be tested for even higher repetition rates than those which were possible in the present experiments.

Since a bipolar pulse may be difficult to apply, and the addition of water seems to be an unreliable method, other methods of reducing the clearing field effect should be tried. For example, other conducting substances could be used to coat the glass, or different coating techniques employed. Different types of glass may be useful. To obtain a decay time for the clearing fields of about  $10^{-4}$  sec., a surface resistivity of the order of  $10^9$  ohms/square is indicated.

Substances other than water, for example halogen compounds should be investigated as a means of reducing the sensitive time since water has the added effect of reducing the brightness of the discharge.

The problem of the long recovery time must be overcome if the tubes are to be used at rates higher than one every few seconds. If the effect is due to a property of the glass, it may be necessary to use some other type of glass, or some other substance which does not show the effect, or it might be possible to develop some way of treating the glass to prevent the emission of electrons.

The application of external clearing fields should be investigated. This would enable a controlled reduction of sensitive time, and might

also reduce the effect of electrons emitted from the glass, or electrons present in the gas due to other causes, by removing them more quickly from the tube and thus reducing the probability of reignition.



APPENDIX 1.

THE DESIGN OF THE M.A.R.S. MAGNET.

The M.A.R.S. solid iron vertical spectograph is designed to measure the momentum spectrum of cosmic ray muons up to 5,000 GeV/c, from their deflection in a known magnetic field, using flash tubes for track location. Since tracks in flash tube arrays can be defined with an accuracy of about 1 mm (Ashton et al (13)), values of magnetic field and path length were required such that a 5,000 GeV/c particle would undergo a 1mm deflection.

Using the relationship:-

	MV	=	B e r
where	MV	=	momentum
	B	=	magnetic field strength
	e	=	charge
	r	=	radius of curvature of path

it was calculated that a field of  $1.6 \text{ Wb} / \text{M}^2$  would deflect the path of a 5,000 GeV/c particle by 1 mm. over a 5 M path. A field of  $1.6 \text{ Wb} / \text{M}^2$  was chosen since it was estimated from a plot of field against current that a further increase in current would not significantly increase the field.

Because of the large scattering of muons in the iron which would introduce an uncertainty into the path location, it was decided to construct the magnet in 4 sections with flash tubes placed in the gaps between them, and to determine the curvature of the path from the measured position at 5 levels, thus giving trajectory location of a greater accuracy than that given by the method used in most previous spectographs for example Ashton et al (30), namely measuring the position at two levels, one at each end of the path in the magnetic field.

Five banks comprising 8 layers of flash tubes 2M long, internal diameter 5.5 mm, external diameter 7.5 mm, and filled with 98% neon and 2% helium at a pressure of 2.4 atmospheres, are used, and electronic readout is employed based on the method of Ayre and Thompson (7). Another 3 banks of 4 layers of tubes, internal diameter 1.6 cm, external diameter 1.8 cm, 2 M long and filled with the same gas mixture at a pressure of 0.8 atmosphere are used to measure low momentum events. For high momentum events the data from

the small diameter tubes is analysed by an IIM 1130 computer.

The spectograph is triggered by a coincidence pulse obtained from 3 scintillation counters placed on top, below and in the centre gap of the magnet.

As the magnet was of a design not previously used, i.e. built in sections, tests were performed on models of the magnet in order to determine the best shape to optimise field strength and uniformity over the area of the flash tube detector, and to ensure a high enough field to obtain the required 1 mm deflection measurable by the flash tubes.

Models were constructed out of  $\frac{1}{2}$ " mild steel sheet, having all dimensions except thickness  $1/24$  those of the proposed magnet. Figure A1.1 shows the final dimensions of the model incorporating 4  $\frac{1}{2}$ " plates to give a  $1/24$  scale model of one complete magnet section.

A current of 50 amps and 374 turns of wire, giving a flux of about  $1.6 \text{ Wb/M}^2$  were chosen. Initially 8 SWG wire was to be used in order to minimise the costs of wire and rectification, but in view of the high temperature attained it was later decided to use 4 SWG wire, thus reducing the heat dissipation. 368 turns of fine wire (30 SWG) were wound on one of the models, and measurements were made of the flux in the iron using a ballistic galvanometer and a single turn of wire through holes drilled  $\frac{1}{4}$ " apart at various positions in the plate. The galvanometer was calibrated by means of a standard mutual inductance.

Measurements were made on models two and four times the thickness by placing several plates together and winding the coils round all of them. The results showed that the uniformity of the field increased as the thickness relative to the area was increased. Measurements were also made on plates with the corners removed, and plates with  $3/8$ " removed from each end in an attempt to optimise the amount of steel used and the field uniformity. Figure A 1.2 shows the variation of flux in the final scale model.

The area of the detectors to be used is  $177 \times 75$  cm. i.e. the area of the existing scintillator, and the flash tubes to be used are 2M long. It was concluded that over this area, the field would not vary by more than 2%.

1/24 SCALE MODEL OF THE M.A.R.S. MAGNET

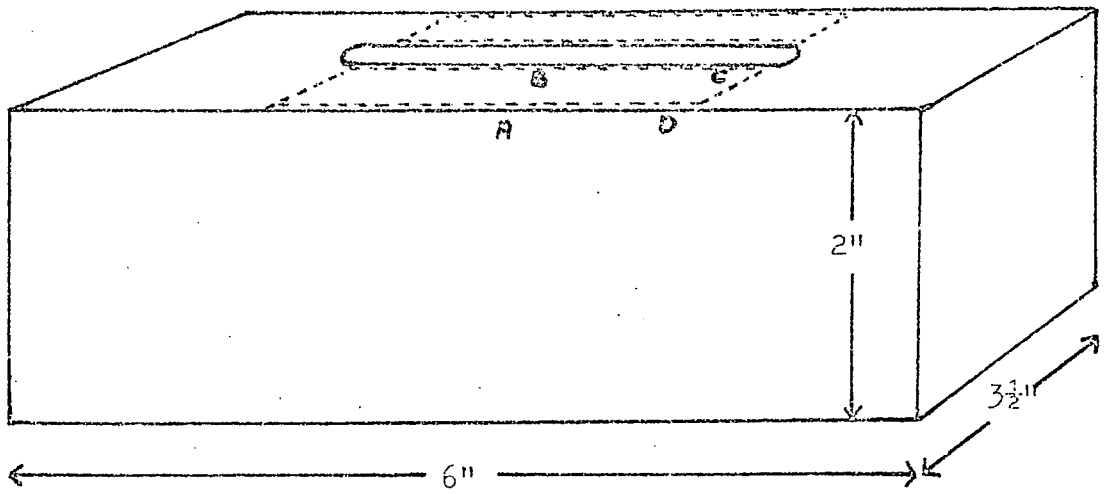

----- Approximate area of the flash tube arrays

figure A1.1

MAGNETIC FLUX VARIATIONS IN THE MODEL

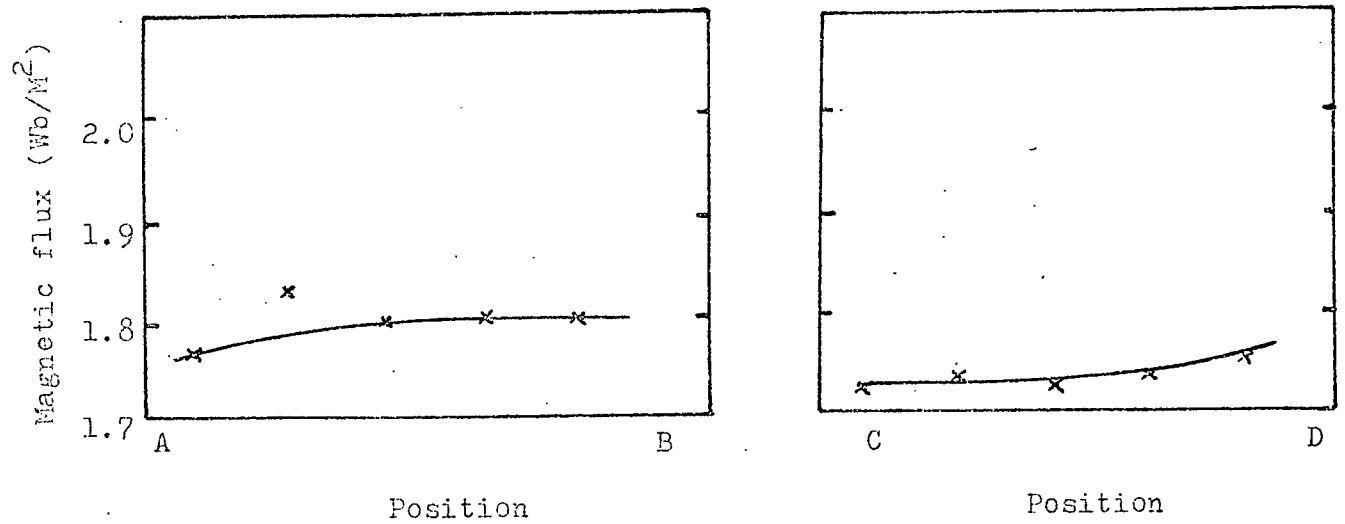

figure A1.2

The magnetic flux in the actual M.A.R.S. magnet has been measured by similar methods since its construction , and the average value found to be  $1.63 \text{ Wb/m}^2$  and that, as expected, the value does not vary by more than 2% over the area of the flash tube detector. Muon events in the spectograph have been studied, and it has been concluded that the expected accuracy of track location by the flash tubes of 1 mm can be obtained.



REFERENCES

- (1) BOTHE AND KOLHÖRSTER  
Nature of high altitude radiation.  
Zeits Physik 56 11 - 12 p751 (1929)
- (2) ANDERSON C.D.  
The positive electron.  
Phys.Rev. 43 491 (1933)
- (3) ROCHESTER AND BUTLER  
Nature 160 855 (1947)
- (4) M<sup>C</sup>CUSKER ET AL.  
11<sup>th</sup> International Conference on Cosmic Rays  
Budapest (1969)
- (5) CONVERSI AND GOZZINI  
The Hodoscope Chamber: A new Instrument for Nuclear  
Research.  
Nuovo Cimento 2 188 (1955)
- (6) FOCARDI ET AL.  
Metodi di Comando Rapido di Rivelatori di Tracce.  
Nuovo Cimento serie 10 vol. 5 p275 (1956)
- (7) AYRE AND THOMPSON  
Digitisation of Neon Flash Tubes.  
Nuclear Instruments and Methods. 69 106 (1969)
- (8) AYRE C.A., BREARE J.M., HOLROYD F.W., THOMPSON M.G.,  
WELLS S.C., AND WOLFENDALE A.W.  
The Durham 5,000 GeV/c Spectrograph: M.A.R.S.  
11<sup>th</sup> International Conference on Cosmic Rays.  
Budapest (1969)

- (9) ACHAR ET AL.  
Detection of Muons Produced by Cosmic Ray Neutrinos  
Deep Underground.  
Phys. Letters 18 196 (1965)
- (10) EARNSHAW ET AL.  
The Momenta of Muons in Extensive Air Showers.  
Proc. Phys. Soc. 90 91 (1967)
- (11) BAGGE ET AL.  
The Extensive Air Shower Experiment at Kiel.  
9<sup>th</sup> International Conference on Cosmic Rays.  
London (1965)
- (12) ASHTON ET AL.  
Ionisation Measurements using a Flash Tube Chamber.  
Physics Department, University of Durham. Internal  
Report. (1971)
- (13) ASHTON ET AL.  
The use of the Neon Flash Tube for the Precise Location  
of Particle Trajectories.  
Nuovo Cimento 8 615 (1958)
- (14) BULL R.M., COATES D.W., NASH W.F., AND RASTIN B.C.  
The Design of Flash Tube Arrays.  
Suppl. Nuovo Cimento 23 39 (1962)
- (15) BULL R.M., COATES D.W., NASH W.F., AND RASTIN B.C.  
A Computer Method for the Analysis of Flash Tube Data.  
Suppl. Nuovo Cimento 23 28 (1962)
- (16) CONVERSI ET AL.  
A New Type of Hodoscope of High Spatial Resolution.  
Suppl. Nuovo Cimento 4 234 (1956)
- (17) GARDENER ET AL.  
The Neon Flash Tube as a Detector of Ionising Particles  
Proc. Phys. Soc. B 70 687 (1957)

- (18) COXELL H. AND WOLFENDALE A.W.  
High Pressure Neon Flash Tubes.  
Proc Phys. Soc. 75 378 (1960)
- (19) BUHEL NIKOVA  
Cross Sections for the Capture of Slow Electrons by O<sub>2</sub>  
and H<sub>2</sub>O Molecules and Molecules of Halogen Compounds.  
Soviet Physics J.E.T.P. 35(8) 5 p783 (1959)
- (20) EVANS W.M. AND BAKER J.C.  
A Short Investigation into the use of Flash Tubes as  
Particle Detectors.  
Rutherford High Energy Laboratory Report. (1971)
- (21) BACON AND NASH  
The Spark Tube.  
Nuclear Instruments and Methods. 37 43 (1965)
- (22) LLOYD J.L.  
On the Efficiency of the Neon Flash Tube.  
Proc.Phys.Soc. 75 387 (1960)
- (23) PICKERSGILL D.  
Notes on the Detailed Characteristics of Flash Tubes.  
Physics Department, University of Durham. Internal  
Report. (1968)
- (24) CRAIG R.  
University of Durham. Ph.D. Thesis. (1969)
- (25) COXELL  
University of Durham. Ph.D. Thesis. (1961)
- (26) HAMPSON  
The Flash Tube Detector.  
University of Nottingham. Ph.D. Thesis. (1970)
- (27) CROUCH M.F.  
Case-Wits-Irvine Converter Hodoscope Efficiency and  
High Voltage Pulsing System.  
Case Western Reserve University Internal Report.

- (28) PACK J.L. AND PHELPS A.V.  
Drift Velocities of Slow Electrons in He, Ne, A, H, and N  
Phys. Rev. 121 3 p798
- (29) COXELL H. ET AL.  
Optical Measurements on Neon Flash Tubes.  
Suppl. Nuovo Cimento 21 series 10 (1961)
- (30) ASHTON ET AL.  
The Momentum Spectrum of Cosmic Ray Muons at Large Zenith  
Angles.  
Proc. Phys. Soc. 87 79 (1966)
- (31) EYEIONS ET AL.  
The Ionisation Loss of Relativistic  $\mu$  Mesons in Neon.  
Proc. Phys. Soc. A 68 793 (1955)
- (32) FISCHER J. AND ZORN G.T.  
Observations on Pulsed Spark Chambers.  
Rev. Sci. Instr. 32 no.5 (1961)
- (33) VON ENGEL  
Ionised Gases  
Clarendon Press (1965)
- (34) MALTER L.  
Phys. Rev. 49 879 (1936)
- (35) STUBBS R.J.  
University of Durham. Private Communication.
- (36) MALTER L.  
Thin Film Field Emission.  
Phys. Rev. 50 48 (1936)
- (37) BROWN S.C.  
Basic data in Plasma Physics  
Wiley (1959)



- (38) HEYN  
Princeton University Thesis (1961)
- (39) MASSEY AND BURHOP  
Electronic and Ionic Impact Phenomena.  
Oxford University Press. (1952)
- (40) VON HIPPEL. A.  
Electronic breakdown of Solid and Liquid Insulators  
Journal of Applied Physics. vol.8 Dec. 1937
- (41) JESSE AND SADAUSKIS  
Phys.Rev. 100 1755 (1955)
- (42) CHIKOVANI G.E. ET AL.  
Nuclear Instruments and Methods 29 p261 (1964)
- (43) ROHATGI V.K.  
J. Appl. Phys. (U.S.A.) 28 No.9 (1957)

ACKNOWLEDGEMENTS

The author wishes to thank Professor G.D.Rochester for the use of laboratory facilities for this work, and Professor A.W.Wolfendale for his continued interest.

She is indebted to Dr.J.M.Breare for his encouragement and supervision.

She is grateful to Dr.F.Ashton for the use of a photograph from the Durham Quark Experiment, to members of the Spark Chamber Group for helpful discussions, Mrs. E.Holroyd who did the typing, Mrs.P.Russell who helped with the diagrams, and members of the technical staff who assisted with construction of apparatus.

The International Research and Development Company, Newcastle upon Tyne, are thanked for the production of the special flash tubes, and the Science Research Council for financial support.

