



Durham E-Theses

Nitrogen ligands in transition metal carbonyl systems

Payling, Catherine A.

How to cite:

Payling, Catherine A. (1969) *Nitrogen ligands in transition metal carbonyl systems*, Durham theses, Durham University. Available at Durham E-Theses Online: <http://etheses.dur.ac.uk/8653/>

Use policy

The full-text may be used and/or reproduced, and given to third parties in any format or medium, without prior permission or charge, for personal research or study, educational, or not-for-profit purposes provided that:

- a full bibliographic reference is made to the original source
- a [link](#) is made to the metadata record in Durham E-Theses
- the full-text is not changed in any way

The full-text must not be sold in any format or medium without the formal permission of the copyright holders.

Please consult the [full Durham E-Theses policy](#) for further details.

NITROGEN LIGANDS IN TRANSITION METAL CARBONYL SYSTEMS

by

Catherine A. Payling, B.Sc.

(St. Mary's College)

A thesis submitted to the University of Durham for the
degree of Doctor of Philosophy

July 1969



MEMORANDUM

The work described in this thesis was carried out in the University of Durham between October 1966 and July 1969. It has not been submitted for any other degree and is the original work of the author except where acknowledged by reference.

Part of this work has been published in the Abstracts of the 4th International Conference on Organometallic Chemistry, Bristol, July 1969.

ACKNOWLEDGEMENTS

I should like to express my sincere gratitude to Dr. M. Kilner, under whose supervision this research was carried out, for his continual advice and encouragement. My thanks are also due to Dr. K. Wade for many helpful discussions.

I am indebted to the Science Research Council for a maintenance grant.

C.A. Payling
Durham, 1969.

SUMMARY

Attempts to introduce some nitrogen ligands into transition metal carbonyl and non-carbonyl systems are described.

Reaction of the lithium and trimethylsilyl derivatives of diphenylketimine with bis(triphenylphosphine)cobalt(II) dichloride gives $(\text{Ph}_2\text{C}=\text{NH})_2\text{Co}^{\text{II}}\text{Cl}_2$ and $(\text{Ph}_2\text{C}=\text{NH})(\text{PPh}_3)\text{Co}^{\text{II}}\text{Cl}_2$ respectively, rather than the expected derivatives containing the anionic ketimino ligand.

$(\text{Ph}_2\text{C}=\text{NH})_2\text{Co}^{\text{II}}\text{Cl}_2$ and $(\text{Ph}_2\text{C}=\text{NH})_2\text{Ni}^{\text{II}}\text{Cl}_2$ are formed by direct reaction of the neutral ligand with the bis(triphenylphosphine)metal dichloride complexes. The cobalt complex has a tetrahedral configuration, while the nickel derivative has a polymeric octahedral structure. The octahedral complex, $\text{Ni}^{\text{II}}\text{Cl}_2 \cdot 2\text{THF}$ is surprisingly formed from $(\text{Ph}_3\text{P})_2\text{Ni}^{\text{II}}\text{Cl}_2$ and THF.

Reactions of diphenylketiminodiphenylmethyl chloride and its Grignard derivative with several metal carbonyl systems and some nickel non-carbonyl compounds are described. The two new manganese carbonyl complexes $\text{Mn}(\text{CO})_4(\text{Ph}_2\text{CNCPh}_2)$ and $\text{BrMn}(\text{CO})_4(\text{Ph}_2\overset{\text{H}}{\text{CNCPh}_2})$ are discussed in terms of possible types of metal-ligand bonding, and a pseudo-allylic, or related structure, is proposed for each compound.

Differences in behaviour of ethyleneimine towards Group VI metal hexacarbonyls and manganese pentacarbonyl bromide are observed. Ready ring opening and polymerisation of the ligand occurs to give metal carbonyl derivatives, but a manganese carbonyl bromide derivative, probably $\text{Mn}(\text{CO})_3(\text{Az})_2\text{Br}$, containing the ligand with the ring still intact, is also formed.

A variety of reactions between nitrite salts and metal carbonyl systems are described. Unstable species are formed in these reactions, but the complex $\pi\text{-CpFe(CO)}_2\text{NO}_2$ can be identified spectroscopically, though it is never isolated free of its decomposition products. Some evidence of formation of nitrosyl complexes in these reactions is described.

CONTENTS

	Page
<u>CHAPTER ONE</u> <u>Nitrogen Ligands in Metal Carbonyl Systems</u>	1
A, General Introduction, 1; B, The Inert Gas Rule, 2; C, Bonding, 6; D, Infrared Spectra, 8; E, Methods of Preparation, 10; F, Reaction Mechanisms, 14; G, Carbonyl Complexes in Organic Syntheses, 16;	
H, Survey of Compounds: 1, Titanium and Vanadium, 19; 2, Chromium, Molybdenum and Tungsten, 20; 3a, Manganese, 38; 3b, Rhenium and Technetium, 48; 4a, Iron, 50; 4b, Ruthenium and Osmium, 68; 5, Cobalt, Rhodium and Iridium, 70; 6, Nickel, Palladium and Platinum, 78.	
 <u>CHAPTER TWO</u> <u>Azomethine Derivatives of Transition Metals</u>	 83
A, Introduction, 83; B, Noncarbonyl Cobalt Complexes, 87; C, Noncarbonyl Nickel Systems, 100; D, Cobalt Carbonyl Derivatives, 106.	
 <u>CHAPTER THREE</u> <u>Reactions of Diphenylketiminodiphenylmethylchloride with Transition Metal Complexes</u>	 118
 <u>CHAPTER FOUR</u> <u>Reactions of the Grignard Derivative of Diphenylketiminodiphenylmethylchloride with Transition Metal Complexes</u>	 138
 <u>CHAPTER FIVE</u> <u>Some Aziridine Derivatives of Transition Metal Carbonyls</u>	 152

		Page
<u>CHAPTER SIX</u>	<u>Reactions of Nitrite Salts with Transition Metal</u>	167
	<u>Carbonyls</u>	
<u>Appendix 1</u>	Experimental Details and Starting Materials	i
<u>Appendix 2</u>	Instrumentation	iii
<u>Appendix 3</u>	Analytical Methods	v
<u>References</u>		

CHAPTER ONE

Nitrogen Ligands in Metal Carbonyl Systems

A. General Introduction

The last decade has seen a rapid expansion in the field of transition metal carbonyl chemistry. The carbonyls themselves have been reviewed^{1,2,3}, as have the anionic carbonyl metallates^{4,5}, metal olefine complexes^{6,7}, perfluoroalkyl metal complexes⁸, π -cyclopentadienyl and π -arene metal derivatives^{9,10}, Lewis base metal carbonyl complexes¹¹, sulphur containing metal carbonyls¹², substitution products of the Group VIB metal carbonyls¹³, photochemical substitutions on metal carbonyls and their derivatives¹⁴ and the kinetics and mechanisms of substitution reactions of metal carbonyl complexes.¹⁵ The use of metal carbonyls in organic syntheses is the subject of a book in two volumes.¹⁶

In this chapter, transition metal carbonyl derivatives containing a nitrogen atom bonded directly to the metal will be reviewed. In the compounds containing simple organonitrogen molecules such as amines, the nitrogen atom donates its lone pair of electrons to the metal, thus forming a σ -bond, but there can be no strengthening of this bond by π -bonding involving filled metal d-orbitals, as the nitrogen atom, being a first row element, lacks suitable orbitals of low enough energy to participate in this type of bonding. However, if the nitrogen atom is part of an unsaturated system, for example an aromatic ring, then the ligand as a whole can act as a π -acceptor. The empty π -orbitals of the unsaturated system are available for overlap with the non-bonding metal orbitals and so a synergic interaction may be possible which would result in a strengthening of the

M-L bond. Particular reference will be made to complexes where this type of interaction is possible, as the work described in this thesis concerns these types of ligands.

No attempt has been made in the review to include all the transition metal nitrosyl compounds, as these form a separate class of compounds, and their chemistry has recently been reviewed.^{17,18}

B. The Inert Gas Rule

One of the most useful and generally applicable concepts in the chemistry of the metal carbonyls and their derivatives is the "effective atomic number" or "rare gas" rule. That is, the central metal atom accepts a number of additional electrons from its surrounding ligands so that it achieves a formally closed shell, or "inert" gas configuration. This simple rule has been very successful in predicting the stoichiometry of complexes, so much so that the few compounds which do not conform to the rule are still considered as "exceptions".

The rule can be applied whatever types of ligands are involved, but many compounds can be regarded in at least two ways for this electron counting procedure. Thus, the compound $\text{Fe}(\text{CO})_4\text{I}_2$ may be considered to be composed of (i) Fe^0 (8 electrons), two I^\cdot radicals (2 x 1 electrons) and four carbonyl groups (4 x 2 electrons), or (ii) Fe^{+II} (6 electrons), two I^- anions (2 x 2 electrons) and the four carbonyl groups (4 x 2 electrons). In either case there is no net charge on the complex, and the total number

of electrons is 18. The apparent difference in formal oxidation state of the metal atom has little real meaning in most cases in which strong metal-ligand bonding exists, although according to the definition of oxidation state, the iodine anion acts as a two electron donor. The assignment of oxidation states to the metal is often only for the purpose of "electron counting".

The assignment of oxidation states to metals forming clusters is more complex, and polynuclear, especially binuclear species are particularly common among the metal carbonyls and their derivatives. Dimanganese decacarbonyl, $Mn_2(CO)_{10}$, exemplifies the simplest type of compound, in which the two halves of the molecule are joined only by a metal-metal bond, but in others, e.g. $Co_2(CO)_8$, bonding also involves bridging carbonyl groups. Bidentate ligands, often found in mononuclear complexes as chelating ligands, can also act as bridges, e.g. ethylenediamine (en) in $M(CO)_4en$, $M = Cr, Mo, W$,¹⁹ and $(CO)_3M(en)_3M(CO)_3$, $M = Cr$,²⁰ Mo .²¹ In some cases, both ligand bridges and a metal-metal bond are required to satisfy the inert gas rule. The group of compounds $[Fe(CO)_3SR]_2$ ^{22a} are diamagnetic, but an electron count gives a total of only 17 electrons per iron atom. The postulated metal-metal bond to complete the electron shell and account for the diamagnetism, has been verified by X-ray studies.^{22b}

In the simplest of metal carbonyl complexes with nitrogen ligands, the ligand is neutral and donates two electrons to the metal, which is formally in a zero oxidation state, e.g. $M(CO)_5py$ ¹⁹ ($M = Cr, Mo, W$, $py = pyridine$).

A few anionic organonitrogen derivatives are known, in which the metal in a +I oxidation state, accepts 2 electrons from the anionic ligand, or alternatively, the metal in a zero oxidation state, accepts one electron from the neutral ligand, e.g. the compound shown in Fig.I.1.²³

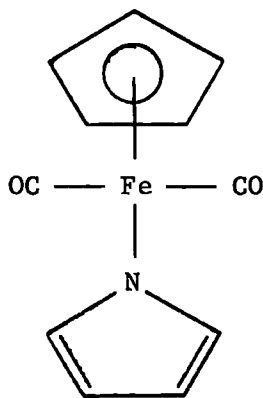

Dicarbonyl- π -cyclopentadienyl-N-pyrrolyliron.²³

Fig.I.1

The nitrogen atom still possesses a lone pair of electrons which could theoretically donate to another metal, thus forming a bridged dimer. No bridged complexes have been reported for pyrrole derivatives, but a bridged amino complex shown in Fig.I.2 has been described, in which each nitrogen donates a total of three electrons to the bonding.^{24a,b} Donors containing the -RC=NR system appear able to complex to metals either by donation of the lone pair, as in the complex shown in Fig.I.3²⁵ or by use of the π -bond, as in the compound shown in Fig.I.4.²⁵ Particular reference will be made to those complexes containing unusual types of co-ordination.

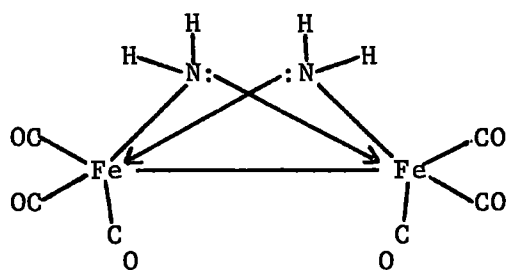

Di- μ -amino-bis(tricarbonyliron).^{24a,b}

Fig.I.2

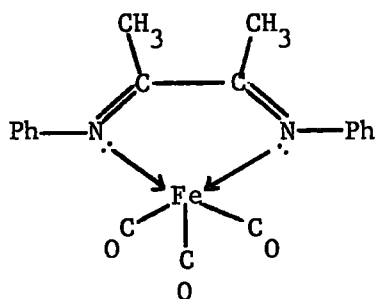

(Diacetylanil)irontricarbonyl

Fig.I.3.²⁵

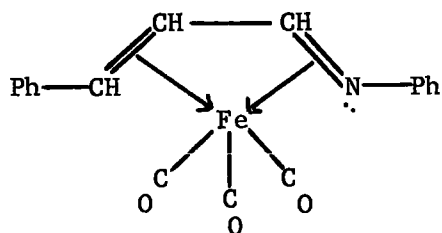

(Cinnamaldehydeanil)irontricarbonyl

Fig.I.4.²⁵

C. Bonding

The bonding between a transition metal and a carbonyl group can be described qualitatively in terms of σ -donor and π -acceptor properties of the carbonyl group. The lone pair of electrons on the carbon atom is in an essentially sp-hybrid orbital, and forms a σ -co-ordinate bond by overlap with a vacant transition metal hybrid orbital of suitable symmetry and energy. In addition, the carbonyl group has π -antibonding orbitals of suitable symmetry and energy which can overlap with filled non-bonding d-orbitals on the metal atom, thus forming M-C π -bonds in two planes perpendicular to each other. A synergic interaction provides a means of avoiding charge separation in the molecule as a whole, and strengthens the M-C bond. Thus, the M-C bond order is expected to be greater than one, while the C-O bond order is less than three.

Many of the ligands found in substituted metal carbonyls possess both σ -donor and π -acceptor properties. The heavier donor atoms in a group possess empty d-orbitals which are available to accept electrons from the metal but ligands bonding via a first row atom lack suitable low-lying empty orbitals and, functioning only as σ -donors they thus form less robust compounds. Unsaturated heterocyclic systems can act as π -acceptors using the empty π -orbitals of the ring-system, and the synergic interaction results in a strengthening of the M-L bond and more stable complexes.

The electron density on the transition metals is usually such that they can participate in this type of double-bonding; empty s, p and d orbitals are

available to accept σ -donation, and the non-bonding d orbitals are at least partially filled and can be used for π -back donation. The electron density is determined initially by the position of the metal atom in the transition series, and its valence state. The ability of the metal to form strong π -bonds depends on the number of electrons in non-bonding d-orbitals after σ -electron acceptance and thus a positive charge on the central atom increases its acceptor ability but decreases its back-bonding ability; a negative charge produces the opposite effects. Double bonding of this synergic type appears essential for the formation of the carbonyls and their derivatives, and requires the metal in a low valence state.

Symmetry considerations also have an effect on the strength of π -bonds between a metal and ligands.^{26,27} For example, in an octahedral Cr^0 complex, the metal accepts six pairs of electrons through σ -bonds, and has six electrons in d-orbitals of suitable symmetry available for backbonding. The orbitals occupied by these electrons are directed in between the ligands, towards unoccupied ligand orbitals of the correct symmetry (d or π orbitals). Thus, octahedral symmetry for a Cr^0 complex allows maximum backbonding to occur.

The ligands in any one complex are in effect competing for the limited bonding potentialities of the central metal atom, and so the exact nature of the bonding between one ligand and the metal will be influenced by the other ligands present. In this way, the strength of a particular metal ligand bond, or the stability of a complex, depends on the interaction of the σ -

and π -bonding capacities of all the ligands present, and the central metal atom. For example, as the carbonyl groups in $\text{Cr}(\text{CO})_6$ are progressively replaced by ligands with less π -acceptor capability, more back donation from the metal to the carbonyl group occurs and the M-C bond order increases, while the C-O bond order decreases. If the ligand L had no back-bonding capacity, then in the complex $\text{Cr}(\text{CO})_3\text{L}_3$ the Cr-C bond order would reach the hypothetical maximum of 2.0 and further displacement of CO groups would be extremely difficult. For each metal there tends to be a particularly stable combination of other ligands and carbonyl groups, balanced according to their σ - and π -bonding capacities, and those of the metal,

D. Infrared Spectra

Infrared spectroscopy has proved one of the most useful tools in studies of transition metal carbonyls and their derivatives. The carbonyl stretching frequencies of metal carbonyl compounds are found between about 2150 and 1650 cm^{-1} , a region normally free of any other absorptions, and a study of the high resolution spectrum of a compound in this area can often be very informative.

The symmetry properties of a carbonyl complex determine the number and type of infrared active vibrational modes which are expected for the carbonyl groups, and the arrangement of the groups in a complex can often be deduced from the absorption pattern.¹¹ The method has certain limitations however, notably that the ligands are usually regarded as points when considering the

overall symmetry of the molecule and splitting of bands is sometimes observed, caused by the local symmetry of the ligand and lowering of the symmetry through crystal packing in the solid. Accidental coincidence of bands is also observed.

The CO stretching frequencies are a reflection of the bonding capabilities of other ligands present in a complex, since they depend upon the C-O bond order. This reflects the M-C bond order which is determined by the other ligands. Thus strongly electronegative groups such as halide ions or perfluoroalkyl and perfluoroacyl groups inductively withdraw charge from the metal, reducing its back-donating ability and resulting in an increased C-O bond order, reflected in the CO stretching frequencies which are higher than in the parent carbonyl complexes.²⁸ Conversely, ligands such as amines, with no π -acceptor properties donate charge to the metal resulting in carbonyl frequencies which are much lower than those of the parent carbonyl.

There have been numerous comparisons of the relative σ -donor and π -acceptor abilities of different ligands^{11,13}, using carbonyl frequencies themselves and the application of semi-qualitative force constant calculations has verified the qualitative conclusions and yielded some new ones.^{11,13} The donor-acceptor properties of ligands are not constant, but vary with the nature of the central atom and its environment. In general, unsaturated nitrogen-containing ligands are thought to possess small acceptor abilities; pyridine, in the disubstituted complexes $[M(CO)_4(py)_2]$ $[M = Cr, Mo, W]$ does accept electrons, but in the $[M(CO)_5py]$ complexes, the 5 carbonyl groups

accept all the electron density and pyridine is purely a donor.¹⁹ A comparison of the force constant-bond order relationship for $(\text{dien})\text{Mo}(\text{CO})_3$ (dien = diethylene triamine) and $(\text{acetonitrile})_3\text{Mo}(\text{CO})_3$ suggests that the $-\text{C}=\text{N}$ bond has a small, but real ability to accept electrons from the metal.¹³

However, there is some discussion in the literature as to the reliability of carbonyl frequency shifts as a measure of the π -bonding abilities of ligands. Angelici²⁹ has studied the CO stretching frequencies of a number of substituted complexes, as a function of the pKa values of the ligands. He assumed that the aqueous pKa values of the ligands are a relative measure of the ability of L to donate σ -bonding electrons to the metal, and by comparing non π -bonding ligands (e.g. amines) and π -bonding ligands (pyridine and phosphines) he concluded that the carbonyl frequency shifts could be explained in terms of σ -bonding only, and could not be rationalised in terms of π -bonding between metal and pyridine or phosphine. In view of the large amount of data which suggests that phosphines and pyridines do π -bond to the metal, Angelici questions the relationship between π -bonding ability of ligands and the CO frequencies of their metal carbonyl complexes.

E. Methods of Preparation

Most of the organonitrogen transition metal carbonyl complexes have been prepared by one of three general synthetic routes. The most common method involves direct displacement of CO from the carbonyl by the ligand, and this

has been achieved under a variety of conditions. Thus $\text{Ni}(\text{CO})_4$ and liquid ammonia react to give $[\text{Ni}(\text{CO})_3\text{NH}_3]$ and $[\text{Ni}(\text{CO})_2(\text{NH}_3)_2]$, both of which disproportionate above -60°C ¹¹, whereas $\text{M}(\text{CO})_6$ ($\text{M} = \text{Cr}, \text{Mo}$) reacts with bipyridyl in dibutyl ether or ligroin at $130-150^\circ\text{C}$ to produce $\text{M}(\text{CO})_4\text{bipy}$.³⁰ Refluxing solvents are often employed, but heating only the carbonyl and ligand in a sealed tube or in an autoclave has effected reaction.

Photochemical initiation of reactions has proved a versatile route to derivatives. This method has the advantage that the reaction can be controlled to give smooth, stepwise displacement of CO, which can be achieved only with difficulty, if at all, by thermal substitution reactions. For example, $\text{W}(\text{CO})_6$ undergoes direct thermal reaction with CH_3CN to give $\text{W}(\text{CO})_3(\text{CH}_3\text{CN})_3$ but $\text{W}(\text{CO})_5(\text{CH}_3\text{CN})$ and $\text{W}(\text{CO})_4(\text{CH}_3\text{CN})_2$ have been prepared photochemically.¹³ The applicability of thermal reactions is limited by the stability of the starting materials and the final products. Photochemical substitutions often occur at much lower temperatures, and so relatively thermally unstable substitution complexes, inaccessible by thermal reactions, can be prepared photochemically. If the metal carbonyl alone is irradiated in a solution of a weakly donating solvent, such as THF, then the resulting metal carbonyl-THF complex can react with a ligand to produce the required complex under exceedingly mild conditions. Strohmeier and his group have investigated these photochemical reactions extensively, from a preparative and a mechanistic point of view, and Strohmeier has published a survey of work in this field.¹⁴

The displacement of substituent groups from mixed complexes, by the desired ligand has proved a widely applicable method, and is again particularly useful when direct displacement of CO from the carbonyl requires too drastic conditions. Thus, for acrylonitrile with the Group VI metals, direct displacement of CO was not feasible, but the series $(\text{CH}_2\text{CHCN})_n\text{M}(\text{CO})_{6-n}$ ($n = 1, 2$ or 3 , $M = \text{Cr}, \text{Mo}, \text{W}$) were prepared by ligand displacement under mild conditions from the corresponding acetonitrile complexes.³¹ The displacement of an aromatic, pseudo-aromatic or a chelating ligand from a complex often (but not always) yields a specific isomer, or a higher substitution product not obtainable through direct displacement, e.g.

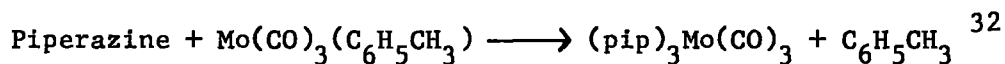
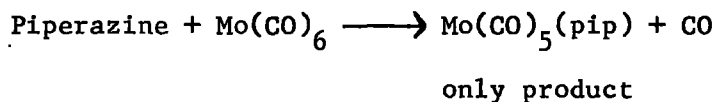

The attack on carbonyl metallate ions by various donor groups is a method which has not been so widely used, but has yielded several complexes, most of which can be obtained directly though e.g.

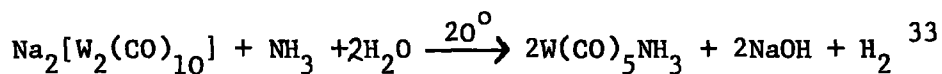

The three general preparative procedures described yield metal carbonyl complexes containing neutral ligands, but different types of reactions are required to introduce anionic ligands into metal carbonyl systems. The most common method of preparing complexes containing anionic ligands involves

metathetical processes of the general type shown in the equation:



If M is a metal carbonyl moiety, then X can be a halogen, in which case Y would probably be an alkali metal, or hydrogen. Alternatively, X can be an alkali metal, usually sodium, and Y would be a halogen. These reactions usually occur under mild conditions and allow ready isolation of the desired product. In addition metal carbonyl halides, and sodium carbonyl metallates are in many cases readily available. An example of this preparative procedure is given in the equation:

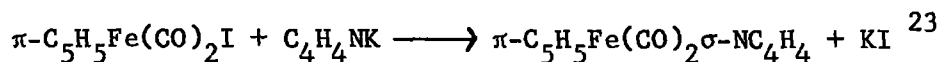

Another preparative method involves reaction of polynuclear metal carbonyls with organonitrogen ligands, when, particularly in the case of the iron carbonyls $\text{Fe}_2(\text{CO})_9$ and $\text{Fe}_3(\text{CO})_{12}$, the resulting compounds contain metal carbonyl fragments linked by bridging nitrogen ligands. Sometimes rearrangement of the ligand occurs, and if the ligand is dimeric it can split, yielding a compound containing two bridging units. Several examples of these types of reaction are described in Section H, and one example is given in the equation:

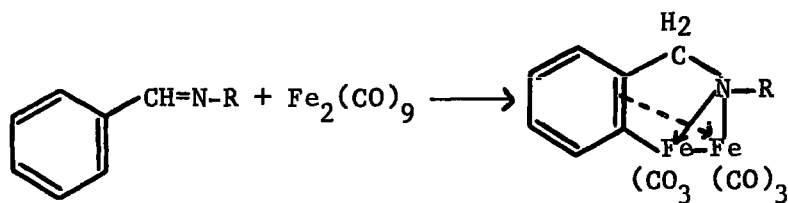

36,182

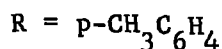

F. Reaction Mechanisms

The number of studies of reaction mechanisms is increasing rapidly, and Angelici³⁴ has recently published a comprehensive review of the work. The two most common ways of studying the kinetics of the reactions are the use of isotopic labelling techniques (especially for CO exchange reactions) and infrared spectroscopy.

For the two types of substitution reactions:

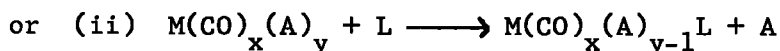
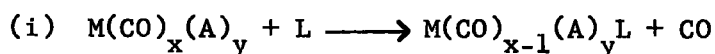

Angelici noted that the vast majority proceed according to the rate law which is either 1st order in the complex and zero order in the ligand, or first order in both complex and ligand. Often a rate law involving both these rate terms is observed but there is kinetic evidence to support S_N1 and S_N2 mechanisms respectively.

In reactions of type (i) it has been found³⁴ that if A is a ligand containing nitrogen or oxygen as the donor atom, or if A is hydrogen or a halogen, then the carbonyl groups are much more labile than in the parent carbonyl. When A contains P, As, Sb, S, Mn, Re, Au as the donor atom, the lability of the carbonyl groups is little different from that of the CO groups in the parent carbonyl. The two types of ligands have been classed as "hard" and "soft" bases, respectively, according to Pearson's classification³⁵, apart from hydrogen, which is a "soft" base but yet has a powerful labilizing

effect on the CO groups. It has been suggested³⁴ that metal carbonyl hydrides react by a different mechanism from most of the other $M(CO)_x A_y$ complexes.

There has so far been no convincing explanation of this labilizing effect.³⁴ π -bonding arguments in fact predict the reverse effect, since the "hard" bases have no π -bonding ability and would thus be expected to increase the charge on the metal causing greater back donation from the metal to the carbonyl groups and strengthening the M-C bond, in relation to the parent carbonyls. In fact π -bonding arguments only very rarely account for observed rates of substitution in the complexes.³⁴

The results have been accounted for in terms of σ -bonding³⁴; the basic ligands donate charge to the metal via a σ -bond thus making it a poorer charge acceptor from the carbonyl groups. However, for S_N1 reactions, it is possible that the stabilization of the activated complex by the more basic nitrogen-ligands, for example, determines the faster rates of CO dissociation. For S_N2 reactions, when A is the chelating ligand o-phenanthroline and its derivatives, it has been shown³⁴ that the rate of reaction decreases as the basicity of the ligand increases. It can be argued that the more basic ligands put a greater charge on the metal and reduce its susceptibility to nucleophilic attack. Steric considerations have also been shown to be of importance³⁴; bulky ligands A hinder nucleophilic attack at the metal and lower the rate of reaction.

Although these different labilizing effects of ligands in carbonyl

complexes are not understood, they are useful synthetically.³⁴ Thus, studies of reaction mechanisms have shown that several factors are important in determining the kinetics and mechanisms of reactions. However, some of the observed effects are not yet fully understood.

G. Carbonyl Complexes in Organic Syntheses

The use of transition metal carbonyl and related complexes as homogeneous and heterogeneous catalysts in cyclisation and polymerisation reactions of organic compounds has become widespread.¹⁶ The reactions often occur under mild conditions compared to uncatalysed reactions and polymerisation reactions are usually extremely stereospecific, very slight changes in the metal catalyst causing different products to form.

Of particular interest here are the reactions of unsaturated organo-nitrogen molecules containing carbon-nitrogen and/or nitrogen-nitrogen multiple bonds in the presence of transition metal carbonyl complexes. A review of these reactions has recently appeared.³⁶ Schiff bases, azo compounds, oximes, phenylhydrazones, semicarbazones, azines, unsaturated imides, amides and nitriles all react with carbon monoxide in the presence of a metal carbonyl catalyst, usually at fairly high temperature and pressure to yield cyclisation products. Schiff bases yield only substituted phthalimidines but all other reactions lead to a mixture of products.

Dicobalt octacarbonyl is by far the most commonly used catalyst in these reactions.³⁶ Other metal carbonyls have been tried, such as $\text{Fe}(\text{CO})_5$, $\text{Ni}(\text{CO})_4$ and $\text{Rh}_2(\text{CO})_8$ but in general they are less efficient than $\text{Co}_2(\text{CO})_8$ or exhibit

no catalytic activity at all. Some studies have been undertaken³⁶ to try and elucidate the mechanism of the catalysed cyclisation of these unsaturated compounds with CO. The reaction rates of a series of anils in which R, then R' and R'' varied, were observed, and it was concluded that the metal carbonyl

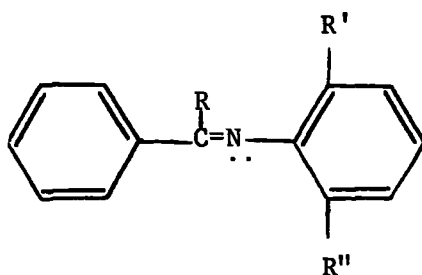

became attached to the lone pair of electrons on the nitrogen atom, rather than the π -electrons of the imino group. The ring closure of benzonitrile with carbon monoxide in the presence of hydrogen and deuterium was also studied³⁶, and the results support the hypothesis that the true catalyst in ring closure reactions of nitrogen compounds is cobalt hydrocarbonyl and not dicobalt octacarbonyl.

Although Rosenthal and Wender³⁶ had insufficient experimental evidence to support a rigorous mechanism of ring closure, they suggested a possible sequence of steps for the cyclisation of aromatic aldehyde and ketone phenylhydrazones (ring closure of these probably parallels that of Schiff bases and azo compounds):

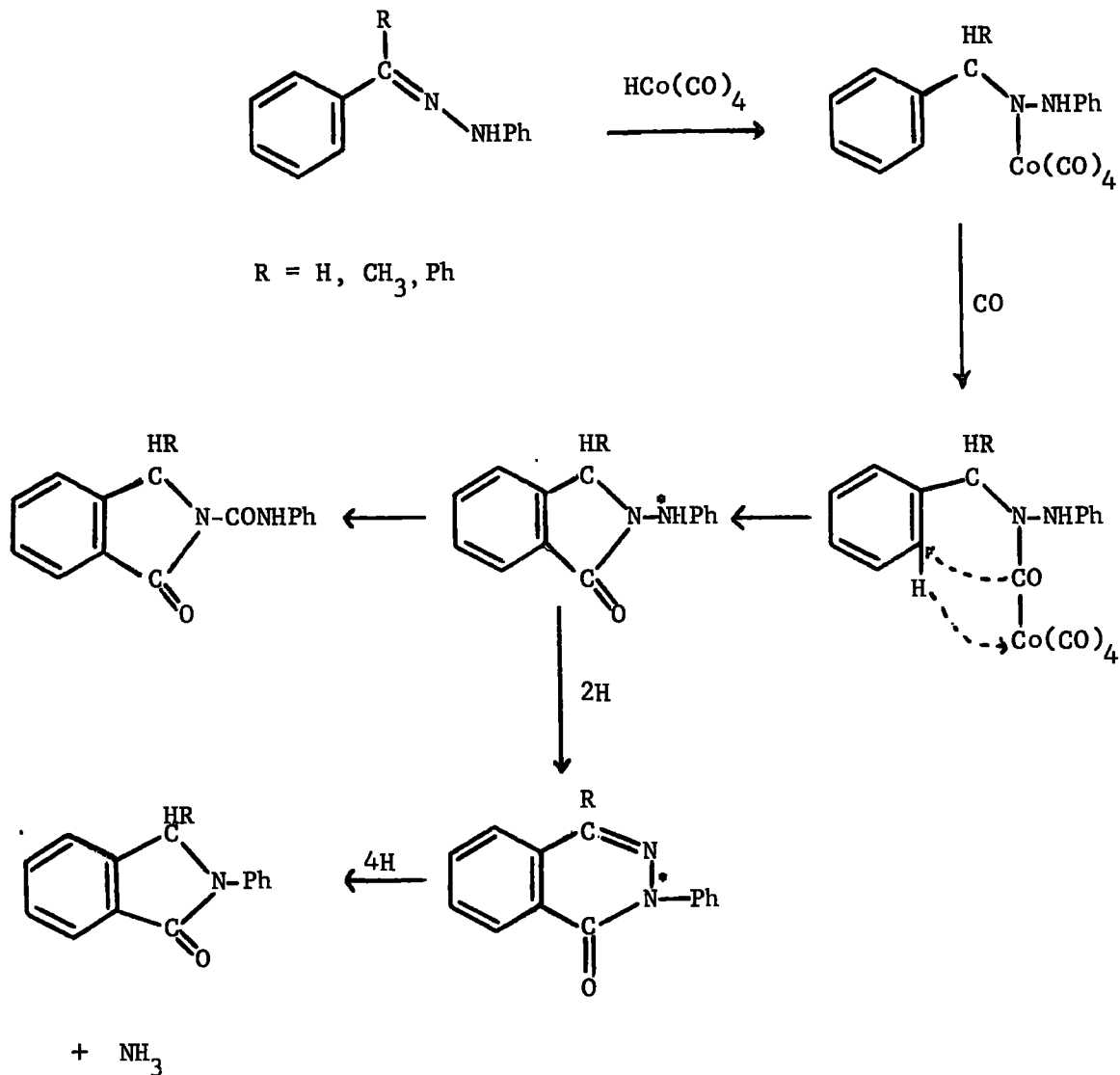

Recently, a number of complexes of some of these unsaturated nitrogen compounds with iron carbonyls have been isolated, (see, for example references 36, 24b) and their structures elucidated. These complexes are interesting in themselves, but they could well prove useful in attempts to

elucidate the mechanisms of the catalysed cyclisation reactions. The complexes will be discussed later in this chapter.

Amongst other metal carbonyl catalysed organic syntheses, the reaction of amines with metal carbonyls to yield formamides and ureas, is of interest.³⁶ Cobalt, ruthenium and manganese carbonyls have been used in these reactions, which are normally carried out at high temperatures and pressures. Much has been learnt mechanistically about these reactions from a study of low temperature, stoichiometric reactions between amines and metal carbonyls.³⁶ The reaction of hydrazine with carbon monoxide in the presence of iron, cobalt, or nickel carbonyls at elevated temperatures and pressures yields semicarbazide and hydrazodicarbonamide, and these reactions have also been studied at low temperatures.³⁶

H. Survey of Compounds

1. Titanium and Vanadium

The paramagnetic hexacarbonylvanadium is the only unsubstituted Group V carbonyl known. Being one electron short of the krypton configuration, $V(CO)_6$ readily disproportionates in the presence of N-bases, yielding $V(CO)_6^-$. Thus reaction of $V(CO)_6$ with liquid ammonia at -30° to $20^\circ C$ yields $[V^{II}(NH_3)_6]$ $[V^{-I}(CO)_6]_2$ and $NH_4[V^{-I}(CO)_6]$, the CO produced being partially evolved as a gas and partially used to form urea.³⁷ Mono- and polydentate aromatic amines e.g. aniline, N,N'-diphenylethylenediamine and o- and p-phenylenediamine react similarly, in benzene, at room temperature. Benzonitrile and aceto-

nitrile react analogously but α - and γ -picolin give tetraco-ordinate V^{II} cations e.g. $[V(\alpha\text{-NC}_5\text{H}_4\text{CH}_3)_4][V(\text{CO})_6]_2$. $HV(\text{CO})_6$ and aqueous ammonia gave eventually $NH_4[V(\text{CO})_6]$.³⁸

Reaction between derivatives of $V(\text{CO})_6$ and nitrogen ligands has not yielded any mixed carbonyl base complexes.³⁹ $V(\text{CO})_6$ reacts with 1,2-bis-(diphenylphosphine)ethane (DP) at 120° to yield $V(\text{CO})_4\text{DP}^{39}$ and $V(\text{CO})_2(\text{DP})_2^{39}$, and with 1,1,1-tris(diphenylphosphinemethylene)ethane (TP) to yield $V(\text{CO})_3\text{TP}^{39}$, but reaction of these derivatives with bipy, o-phen, and tripy (2,2',2''-tripyriddy) results in elimination of both the phosphorus ligands and all the CO groups, giving $V^o(\text{bipy})_3^{39}$, $V^o(\text{o-phen})_3^{39}$ and $V^o(\text{tripy})_2^{39,40}$

Cyclopentadienylvanadium tetracarbonyl and cyclopentadienyltitanium dicarbonyl react with bipy, o-phen and tripy with loss of cyclopentadiene and carbonyl groups, yielding $M(\text{bipy})_3$, $M(\text{o-phen})_3$ and $M(\text{tripy})_2$ ($M = V, Ti$).⁴¹

2. Chromium, Molybdenum and Tungsten

As Table I.1 shows, the majority of Group VI metal carbonyl nitrogen derivatives are simple substitution products of the hexacarbonyls with aliphatic and aromatic amines. All three methods of preparation mentioned above have been used to obtain these derivatives, in which one, two, three and occasionally four CO groups have been displaced from the parent carbonyl. Some representative examples of the preparative methods are given in the equations:

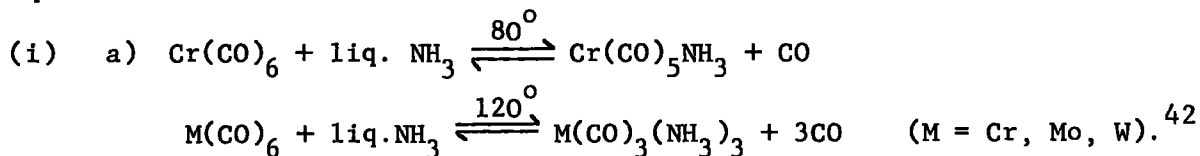

Table I.1. Group VI Metal Carbonyl Complexes(i) Monodentate ligands

<u>Ligand</u>	<u>Metal</u>	<u>M(CO)₅L</u>	<u>cis-M(CO)₄L₂</u>	<u>cis-M(CO)₃L₃</u>
NH ₃	Cr	42,45,47,52	-	20,42,44
	Mo	33,46,48,52	-	21,33,42
	W	33,52,54	-	42,43
C ₅ H ₅ N (py)	Cr	19,45,47,55, 56,57,59	19,65	44,64,65
	Mo	19,46,48,50, 57,62,63,76	19,33,46,48 50,57,63	65,93
	W	19,33,49,54, 57,76	19,33,57	66,93
CH ₃ CN	Cr	31,61,79,80	31,61,80	31,61,77
	Mo	31,62,80	31,61,78,80	31,61,77,80
	W	31,61,78,80 81	31,61,78,80 81	31,61,77,80,81
CH ₂ =CHCN	Cr	31,94	31	-
	Mo	31	31	31
	W	31,82,83,94	31	31,83
C ₆ H ₁₁ NH ₂ (cyclohexylamine)	Cr	46,19,61	-	-
	Mo	19,46,61,62	-	50
	W	19,49,53,61	-	-
C ₆ H ₅ NH ₂	Cr	45,55,56,57	-	-
	Mo	-	-	50
	W	49,51,53,57	-	-
p-NH ₂ C ₆ H ₄ NH ₂	Cr	55	-	-
	Mo	-	58	-
	W	33	-	-
C ₅ H ₁₀ NH (piperidine) (pip)	Cr	52,60	60	-
	Mo	52,60,62	60	-
	W	52,54,60	60	-
HN(CH ₂ CH ₂) ₂ NH (piperazine)	Mo	46	-	32
H ₂ NC ₆ H ₄ N (4-aminopyridine)	Mo	-	58	58

<u>Ligand</u>	<u>Metal</u>	<u>M(CO)₅L</u>	<u>cis-M(CO)₄L₂</u>	<u>cis-M(CO)₃L₃</u>
C ₅ H ₆ N ₂ (2-methylpiperazine)	Cr	-	30	-
	Mo	-	30	-
C ₄ H ₈ NH (pyrrolidine)	Cr	52	-	-
	Mo	52,32	32	-
	W	52,32	32	-
O(CH ₂ CH ₂) ₂ NH (morpholine)	Cr	32	-	-
	Mo	32	32	32
	W	32,49,53,54	32	-
o-NH ₂ C ₆ H ₄ NH ₂	Cr	55		
Et ₃ N	Cr	52,60		
	Mo	52		
	W	52,60		
(CH ₃) ₂ C ₅ H ₃ N (2,6-lutidine)	Cr	67		
4-ClC ₅ H ₄ N	Cr	67		
C ₉ H ₇ N quinoline (quin)	Cr	67		
	Mo	30,67		
C ₉ H ₇ N (isoquinoline)	Cr	67		
α-picoline	Cr	67		
urotropin (hexamethylenetetra- mine)	Mo	30		
isotropin	Cr	67		
PhCN	Cr	79		

<u>Ligand</u>	<u>Metal</u>	<u>M(CO)₅L</u>	<u>Ligand</u>	<u>Metal</u>	<u>M(CO)₅L</u>
CH ₃ NH ₂	Cr Mo W	45,85 86 54,85	PhNHNH ₂	Mo	46
C ₂ H ₅ NH ₂	Cr Mo W	45,52,85 52,85 52,85	Me ₂ NH	Cr Mo W	52,85 52,85 49,52,53, 54,85
NH ₂ NH ₂	Mo	46	n-C ₆ H ₁₃ NH ₂	Cr Mo W	52 52 52
ethylenediamine (en)	Mo	46	n-C ₅ H ₁₁ NH ₂	Cr Mo W	52 52 52
HC(CH ₂ CH ₂) ₃ N	W	49,53	Me ₃ N	Cr Mo W	52 52 52,53,54
4-BrC ₆ H ₄ NH ₂	W	49,51,53	4-CH ₃ C ₅ H ₄ N	W	49,53
4-CH ₃ OC ₆ H ₄ NH ₂	W	49,51,53	(CH ₃) ₂ CHNH ₂	W	49,53
4-CH ₃ C ₆ H ₄ NH ₂	W	51			
4-BrC ₅ H ₄ N	W	49,53			

(ii) Bidentate ligands

<u>Ligand</u>	<u>Metal</u>	<u>M(CO)₄L</u>	<u>Ligand</u>	<u>Metal</u>	<u>M(CO)₄L</u>
8-aminoquinoline	Cr	30	1,2-diamino-2-methylpropane	Cr	95
(C ₄ H ₈ N) ₂ CH ₂	Mo	30	(C ₅ H ₁₀ N) ₂ CH ₂	Mo	30
Cyclohexane-1,2-diamine	Cr	55	(Et ₂ N) ₂ CH ₂	Mo	30
N,N,N',N'-tetramethyleneethylenediamine	Cr	88	1-propylene-diamine	Cr Mo W	89 89 89

<u>Ligand</u>	<u>Metal</u>	<u>M(CO)₄L</u>	<u>M(CO)₂L₂</u>
Phenanthroline (o-phen)	Cr	44, 45, 65, 71, 84, 89	72
	Mo	65, 84, 89	71
	W	66, 84, 89	71
Bipyridyl (Bipy)	Cr	19, 30, 45, 70, 73, 74, 76, 84, 89	72
	Mo	19, 30, 68, 73, 75, 76, 84, 89	71
	W	19, 33, 66, 73, 76, 84, 89	71
H ₂ NC ₂ H ₄ NH ₂ (ethylenediamine) (en)	Cr	19, 45, 47, 61, 89	
	Mo	19, 46, 61, 89	
	W	19, 61, 89	
trimethylenediamine	Cr	89	
	Mo	89	
	W	89	

(iii) Tridentate ligands

<u>Ligand</u>	<u>Metal</u>	<u>M(CO)₃L</u>	
diethylenetriamine (dien)	Cr	19, 61, 68, 69, 87	
	Mo	19, 21, 61, 68, 86	
	W	19, 61, 68	
2,2',2''-tripyridyl	Mo	108	
	W	108	
$\overline{\text{CH}_2-\text{N}-\text{RCH}_2-\text{N}-\text{RCH}-\text{NR}}$			
	R = CH ₃	Cr	30
	= C ₂ H ₅	Mo	30

(iv) Polynuclear derivatives containing nitrogen bridges

<u>Compound</u>	<u>Ref.</u>
m-Phenylenediamine $[\text{Cr}(\text{CO})_5]_2$	55
p-Phenylenediamine $[\text{Cr}(\text{CO})_5]_2$	48,55,59
p-Phenylenediamine $[\text{Mo}(\text{CO})_5]_2$	59
1,3,5-Triaminobenzene $[\text{Cr}(\text{CO})_5]_3$	55
Piperazine $[\text{Mo}(\text{CO})_5]_2$	32
Piperazine $[\text{W}(\text{CO})_5]_2$	32
$(\text{CO})_3\text{Cr}(\text{en})_3\text{Cr}(\text{CO})_3$	20
$(\text{CO})_3\text{Mo}(\text{en})_3\text{Mo}(\text{CO})_3$	21,50

(v) Mixed Derivatives

<u>X</u>	<u>Y</u>	<u>M</u>	<u>M(CO)₃XY</u> <u>Ref.</u>	<u>M(CO)₂XY₂</u> <u>Ref.</u>
bipy	NH ₃	Cr, Mo, W	42	-
o-phen	NH ₃	Cr, Mo, W	42	-
bipy	py	Mo W	90,91,93 93	- -
o-phen	py	Mo, W	93	-
o-phen	P(OEt) ₃	Mo	91	91
bipy	PPh ₃	Mo W	90,91,93 93	91,93
bipy	SPh ₂	Mo	90,91	
bipy	P(OEt) ₃	Mo	91	91
o-phen	PPh ₃	Mo W	91,93 93	91,93
bipy	SO ₂	Mo W	93 93	93
o-phen	SO ₂	Mo, W	93	
(py) ₂	SO ₂	Mo, W	93	

(vi) Hepta-co-ordinate and related derivatives

<u>Compound</u>	<u>Ref.</u>	
[Mo(bipy)(CO) ₃ Br ₂]	73,98	
[W(bipy)(CO) ₃ Br ₂]	73	
[W(bipy)(CO) ₃ I ₂]	73	
[W(bipy)(CO) ₂ (HgCl) ₂]	73	
Mo(py) ₂ (CO) ₃ Cl ₂	98	
Mo(bipy)(CO) ₃ Cl ₂	98	
Mo(o-phen)(CO) ₃ Br ₂	98	
Mo(o-phen)(CO) ₃ Cl ₂	98	
[Mo(CO) ₂ (bipy) ₂ I]I ₃	99	
[Mo(CO) ₂ (o-phen) ₂ I]I ₃	99	
[Mo(bipy) ₂ (CO) ₂ I]I	99	
[W(o-phen) ₂ (CO) ₂ I]I	99	
[Mo(bipy)(CO) ₃ I ₂] ₂	73	(halogen bridged)
[Mo(o-phen) ₂ (CO) ₂ I]I	99	

(vii) π-arene derivatives

(Mesitylene)Cr(CO) ₂ (quin)	122
(Mesitylene)Cr(CO) ₂ (py)	121,122
(tere)Cr(CO) ₂ (NCPh)	120,122
(tere)Cr(CO) ₂ (NCMe)	120
(tere)Cr(CO) ₂ (quin)	120
(tere)Cr(CO) ₂ (aniline)	120

<u>Compound</u>	<u>Ref.</u>
(tere)Cr(CO) ₂ (py)	121,122
(tere)Cr(CO) ₂ (pip)	121,122
(Benzene)Cr(CO) ₂ py	121,122
(Benzene)Cr(CO) ₂ (quin)	122
[(CH ₃) ₆ C ₆]Cr(CO) ₂ (quin)	122
(Benzene)Cr(CO) ₂ (CH ₂ =CH-CN)	94
(Mesitylene)Cr(CO) ₂ (CH ₂ =CH-CN)	94
(tere)Cr(CO) ₂ (CH ₂ =CH-CN)	94

[tere = terephthalic acid dimethyl ester (CH₃CO₂)₂C₆H₄].

(viii) Cyclopentadienyl and Related Derivatives

$\pi\text{CpMo}(\text{CO})_2(\text{PhN=N})$	102,103
$\pi\text{CpMo}(\text{CO})_2(\text{p-CH}_3\text{C}_6\text{H}_4\text{N=N})$	102
$\pi\text{CpMo}(\text{CO})_2(\text{p-CH}_3\text{OC}_6\text{H}_4\text{N=N})$	101,102
$\pi\text{CpMo}(\text{CO})_2(\text{p-NO}_2\text{-C}_6\text{H}_4\text{N=N})$	102
$\pi\text{CpMo}(\text{CO})_2(\text{anthraquinone-N=N})$	102
$\pi\text{CpW}(\text{CO})_2(\text{PhN=N})$	103
$[\pi\text{CpM}(\text{NH}_3)(\text{CO})_3]^+\text{reineckate}^-$ (Mo and W)	106
$[\pi\text{CpM}(\text{NH}_3)(\text{CO})_3]^+\text{BPh}_4^-$ (Mo and W)	106
$[\pi\text{CpM}(\text{N}_2\text{H}_4)(\text{CO})_3]^+\text{reineckate}^-$ (Mo and W)	106
$[\pi\text{CpM}(\text{N}_2\text{H}_4)(\text{CO})_3]^+\text{BPh}_4^-$ (Mo and W)	106
$[\pi\text{CpM}(\text{CO})_2(\text{bipy})]^+\text{PF}_6^-$ (Mo and W)	107
$[\pi\text{CpM}(\text{CO})_2(\text{o-phen})]^+\text{PF}_6^-$ (Mo and W)	107
$[\pi\text{CpM}(\text{CO})_2(\text{CH}_3\text{CN})_2]^+\text{PF}_6^-$ (Mo and W)	107

<u>Compound</u>	<u>Ref.</u>
$[\pi\text{CpMo}(\text{CO})_2(\text{CH}_3\text{CN})(\text{PPh}_3)]^+\text{PF}_6^-$	107
$\pi\text{CpMo}(\text{CO})_2(\text{COCH}_2\text{C}_5\text{H}_4\text{N})$	105

(ix) Thiocyanate and related derivatives

<u>Compound</u>	<u>Metal</u>	<u>Ref.</u>
$(\text{CH}_3)_4\text{N}^+[\text{M}(\text{CO})_5\text{NCS}]^-$	Cr Mo W	109, 111, 119 109 109
$[\text{AsPh}_4]^+[\text{W}(\text{CO})_5\text{NCO}]^-$		110
$[\text{Ni}(\text{phen})_3]^{2+}[\text{Cr}(\text{CO})_5\text{NCO}]_2^-$		45
* $[(\text{CO})_5\text{Cr}-\text{NCS}-\text{Cr}(\text{CO})_5]$		111, 119
$[\text{Ni}(\text{phen})_3]^{2+}[(\text{CO})_5\text{Cr}-\text{NCS}-\text{Cr}(\text{CO})_5]_2^-$		112, 119
$[\text{N}(\text{CH}_3)_4]^+[(\text{CO})_5\text{Cr}-\text{NC}-\text{Cr}(\text{CO})_5]$		112, 119
* $\text{Cr}(\text{CO})_5\text{NCS}$		113, 119
$[\text{Et}_4\text{N}]^+[\text{Cr}(\text{CO})_5\text{NC}(\text{CN})_2]^-$		114
$[\text{AsPh}_4]^+[\text{Mo}(\text{CO})_5\text{NC}(\text{CN})_2]^-$		114
$[\text{Et}_4\text{N}]^+[\text{W}(\text{CO})_5\text{NC}(\text{CN})_2]^-$		114
$[\text{M}(\text{CO})_5\text{NCH}]$	Cr, W	115
$[(\text{CO})_5\text{M}-\text{NCCN}-\text{M}(\text{CO})_5]$	Cr, Mo, W	116
$(\text{Ph}_3\text{P})_2\text{N}^+[\text{M}(\text{CO})_5\text{NCS}]^-$	Cr, W	117
$(\text{Ph}_3\text{P})_2\text{N}^+[(\text{CO})_5\text{M}-\text{SCN}-\text{M}(\text{CO})_5]^-$	Cr, W	117
$(\text{Ph}_3\text{P})_2\text{N}^+[(\text{CO})_5\text{M}-\text{CN}-\text{M}(\text{CO})_5]^-$	Cr, W	117
$\pi\text{CpMo}(\text{CO})_3\text{NCS}$		118

* paramagnetic

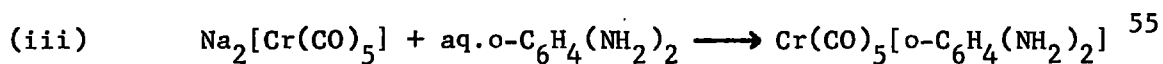
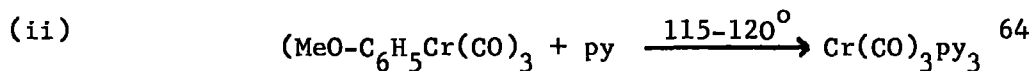
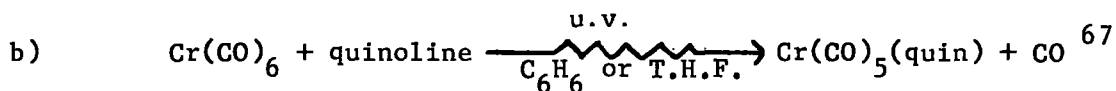

Bi- and poly-dentate ligands have also yielded many derivatives. Whereas monodentate N-donors do not replace more than 3 CO groups from the parent hexacarbonyl, o-phenanthroline and bipyridyl, under drastic conditions give $\text{M(CO)}_2(\text{o-phen})_2$ or $\text{M(CO)}_2(\text{bipy})_2$.^{71,72} It is interesting to note that some potential chelating ligands prefer to form bridged compounds, or to act as monodentate ligands. Thus piperazine ($\text{HN(CH}_2\text{CH}_2)_2\text{NH}$) yields $[(\text{CO})_5\text{MHN(CH}_2\text{CH}_2)_2\text{NHM(CO)}_5]$, $\text{M} = \text{Mo}$, W ³², but also $\text{Mo(CO)}_5(\text{HN(CH}_2\text{CH}_2)_2\text{NH})$.⁴⁶ Similarly m- and p-phenylenediamine yield $(\text{CO})_5\text{Cr(o- or p-C}_6\text{H}_4(\text{NH}_2)_2)\text{Cr(CO)}_5$,⁵⁵ but also $\text{Cr(CO)}_5(\text{o- or p-C}_6\text{H}_4(\text{NH}_2)_2)$.⁵⁵ Ethylenediamine acts as a chelate in $\text{M(CO)}_4\text{en}$ complexes ($\text{M} = \text{Cr}$, Mo , W ^{19,61,89}), but 3 molecules bridge in the complexes $(\text{CO})_3\text{M(en)}_3\text{M(CO)}_3$ ($\text{M} = \text{Cr}$,²⁰ Mo ^{21,50}). Urotropin (hexamethylenetetramine) has 4 potential donor sites, but acts as a monodentate ligand in $\text{Mo(CO)}_5(\text{urotropin})$.³⁰ Presumably steric effects are important in determining the types of derivatives formed with each ligand.

In the nitrile complexes of the Gp.VI metals the ligand may bond to the metal via a σ -bond from the lone pair on the nitrogen, or from the CN multiple bond. In addition, acrylonitrile ($\text{CH}_2=\text{CHCN}$) can form a π -complex through the olefinic double bond. Infrared and n.m.r. spectroscopic

techniques have been used to show that bonding is through the nitrogen lone pair in all the complexes shown in Table I.1.(i) except $M(CO)_3(CH_2=CHCN)_3$ ($M = Mo,^{31} W,^{31,83}$) when π -bonding from the olefinic double bond occurs.

Mixed complexes of the type $M(CO)_3XY$ (where $X = o$ -phen or bipy, $Y =$ a monodentate ligand) are readily prepared by direct displacement of one CO group, and in some cases displacement of a 2nd CO has been achieved to give $M(CO)_2XY_2$ complexes. Some of the complexes are listed in Table I.1.(v). In addition, Houk and Dobson⁹² have prepared complexes with $Y = py, PPh_3, P(OEt)_3, (C_6H_{11})NH_2, CH_3CN, (C_8H_{17})_3P, (n-C_4H_9)_3P, Ph_3As, (i-C_3H_7O)_3P, (n-C_4H_9O)_3P, (CH_3O)_3P, (C_5H_5O)_2HOP, Ph_3Sb, Ph_3Bi, Ph_2Se, DMF, CH_3CONH_2, CH_3CSNH_2, (NH_2)_2CS, (PhO)_3P,$ and studied their i.r. spectra.⁹² Angelici and Graham⁹⁵ have studied the rate of reaction of $Cr(CO)_4(X-o-phen)$ with $P(OCH_2)_3CCH_3(L)$ to give $Cr(CO)_3L(X-o-phen)$, where $X = 5,6$ -dichloro-, 5-nitro-, 4,7-diphenyl-, 3-methyl-, 3,5,7-trimethyl-, 3,4,7,8-tetramethyl- and 3,4,6,7-tetramethyl-.⁹⁵ The analogous $Mo(CO)_4(X-o-phen)^{96}$ and $W(CO)_4(X-o-phen)^{96}$ also react with various ligands ($L = P(OC_2H_5)_3, PPh_3, P(OPh)_3, P(n-C_4H_9)_3, P(OCH_2)_3CCH_3$ and $PO_3C_6H_9$), to give $M(CO)_3L(X-o-phen)$.⁹⁶ For all the $Cr(CO)_4(X-o-phen)$ complexes, the reactions were found to proceed according to a first order rate law, and were independent of the concentration of L .⁹⁵ But the reaction rate increases with increasing basicity of $X-o-phen$, contrary to π -bonding arguments, and it is suggested that the more basic chelates stabilize the transition state to a greater extent than weaker bases. For the Mo and W complexes a two-term rate law is observed.⁹⁶

The seven-co-ordinate complexes listed in Table I.1.(vi) are all diamagnetic, unstable complexes. They have been prepared either by the oxidation of $M(CO)_4(\text{bipy})$ or $M(CO)_4(\text{o-phen})$ with halogen,^{73,99} or by the addition of py, o-phen, or bipy to a solution of the dihalogeno-compounds $[M(CO)_4X_2]_2$.⁹⁸ In addition, stable nonionic heptaco-ordinate compounds of the type $\text{bipy}(CO)_3XMM'X_3$ ¹⁰⁰ (where $M = Mo, W$, and $M'X_3 = GeCl_3, GeBr_3, GeI_3, SnCl_3, SnBr_3, SnI_3, SnCl_2CH_3, SnCl_2C_4H_9, SnCl_2C_2H_5, SnCl_2C_6H_5, SnCl(C_6H_5)_2, GeCl_2C_6H_5$), have been prepared by an "oxidative elimination" reaction of the type:

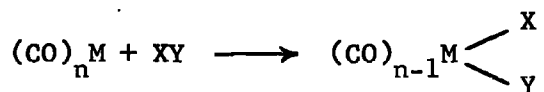

between $M(CO)_4\text{bipy}$ and compounds of the type $M'X_4$. A few analogous compounds with o-phen¹⁰⁰ instead of bipy have also been prepared. The i.r. and n.m.r. data on these complexes suggest that they exist in 2 isomeric forms in solution.¹⁰⁰

Several arene metal carbonyl derivatives of the type $(X-C_6H_5)Cr(CO)_2L$ are listed in Table I.1.(vii). Complexes with substituents in the benzene ring have been prepared to study the effect of X groups on the stability of the complexes.^{94,120,121,122} Electron-withdrawing groups reduce the charge on the metal and encourage $L \rightarrow Cr$ donation, but electron releasing groups favour $Cr \rightarrow L$ back bonding. As expected from these arguments, terephthalic acid forms more stable mixed complexes with poor π -acceptor ligands than does mesitylene.¹²⁰ In the complexes with $L = CH_2=CH-C\equiv N$ ⁹⁴, the type of

bonding between acrylonitrile and the metal was of particular interest. I.R. and n.m.r. techniques showed that the compounds all contained $\sigma\text{N} \longrightarrow \text{M}$ bonds, except for $(\text{CH}_3)_6\text{C}Cr(\text{CO})_2(\text{CH}_2=\text{CHCN})$, which contained a π -olefinic-metal bond. This can be readily understood, since the six methyl groups in the benzene ring will donate charge to the metal, thus discouraging donation of the nitrogen lone pairs to the metal.

Of the π -cyclopentadienyl derivatives listed in Table I.1.(viii), those of the type $\pi\text{CpM}(\text{CO})_2(\text{RN}_2)$ are of special interest. They are prepared by the reaction of $\text{Na}[\pi\text{CpMo}(\text{CO})_3]$ with the diazonium salts $\text{RN}_2^+\text{BF}_4^-$ or $\text{RN}_2^+\text{PF}_6^-$ ¹⁰², or in the case of $(\pi\text{CpM}(\text{CO})_2\text{PhN}_2)$, by the reaction of $\pi\text{CpM}(\text{CO})_3\text{H}$ with phenylhydrazine.¹⁰³ The ligand RN_2^+ is formerly isoelectronic with the NO^+ ligand in the same way that RNC is related to CO . The complexes are somewhat air-sensitive, but are non-ionic and diamagnetic, having the expected n.m.r. spectrum. Thus, in these covalent arylazo derivatives the neutral RN_2 -group must be donating 3 electrons to the metal, so that it has the inert gas configuration (c.f. NO in nitrosyl complexes).

The thiocyanate and related compounds shown in Table I.1.(ix) form an interesting class of compounds, as the possibility of linkage isomerism exists. I.R. studies of these complexes have been interpreted as showing the types of bonding indicated in the table.¹⁰⁹⁻¹¹⁹ The anionic Cr and W complexes are stable, but $\text{Me}_4\text{N}^+[\text{Mo}(\text{CO})_5\text{NCS}]^-$ ¹⁰⁹ and the neutral paramagnetic compounds are unstable.^{111,113,119} The binuclear anions have no bridging carbonyl groups and the two metal atoms are joined by a linear $-\text{NCS}-$,^{112,117,119}

-NC-,^{112,117,119} or -NCCN-¹¹⁶ bridge. Reaction between π -CpMo(CO)₃H and (SCN)₂ yields both π -CpMo(CO)₃SCN and π -CpMo(CO)₃NCS, separable by column chromatography. The S-bonded isomer, in acetonitrile or chloroform solution at 35°C isomerises to the N-bonded isomer. With π -CpW(CO)₃H and (SCN)₂, only the S-bonded isomer was obtained and no isomerism in solution was observed for this compound.¹¹⁸

A few miscellaneous compounds not listed in the tables need to be mentioned. Bock and Dieck¹²³ have prepared an interesting series of metal carbonyl derivatives with non-aromatic nitrogen- π systems. Reaction of dialkyl cyanamides R₂N-CN with Cr and Mo hexacarbonyls in hydrocarbon solvents gives mono-, di- and tri-substituted derivatives. Irradiation at 20-30°C yielded (R₂N-CN)M(CO)₅ and (R₂N-CN)₂M(CO)₄, whereas heating at 50-60°C gave (R₂N-CN)₂M(CO)₄ and (R₂N-CN)₃M(CO)₃. The ligands used were

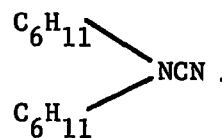
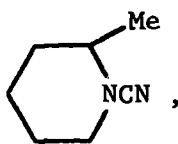
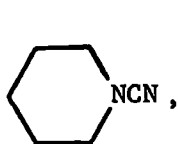
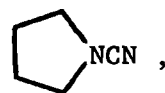

I.R. studies indicated that the metal-ligand bonding is via the lone pair of electrons on the terminal nitrogen, and that the ligands have little π -acceptor ability.¹²³ Reaction of e.g. cis-bis(cyano-piperidine)-molybdenum tetracarbonyl with other ligands such as diacetylhydrazone, triphenylph-

osphinimides and 1,4-diazabutadiene gave $(\text{CH}_3-\text{C}=\text{N}-\text{NH}_2)_2 \text{Mo}(\text{CO})_4$,

$(\text{Ph}_3\text{P}=\text{NH})_2 \text{Mo}(\text{CO})_4$ and $\text{CH}_3-\text{C}(\text{NH}_2)=\text{N}-\text{Mo}(\text{CO})_4-\text{N}(\text{NH}_2)-\text{C}(\text{NH}_2)-\text{CH}_3$ respectively.¹²³

In the reaction between $\text{Mo}(\text{CO})_6$ and diallyl-cyanamide

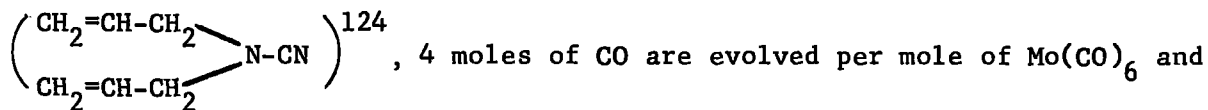

, 4 moles of CO are evolved per mole of $\text{Mo}(\text{CO})_6$ and a dimeric complex is formed, which from i.r. and n.m.r. spectroscopic evidence, is assigned the structure shown in Fig.I.5.

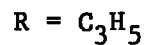
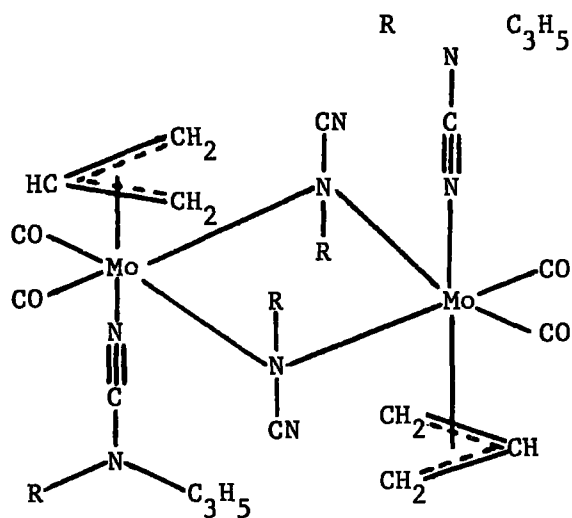
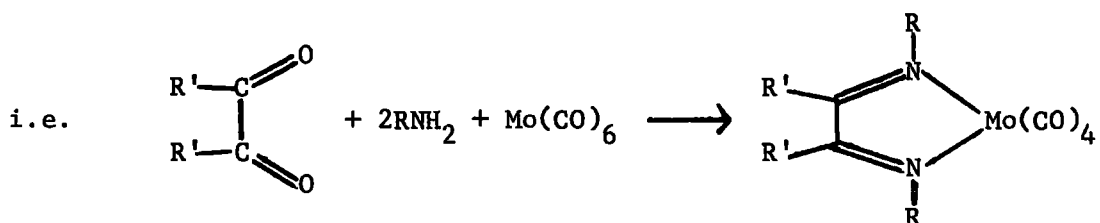

Fig.I.5.

The analogous compound was prepared from methyl-allyl-cyanamide
($\text{R} = \text{CH}_3$).¹²⁴

The non-bonding orbitals of cis-anti-1,4-diaza-1,3-butadienes are in positions which are geometrically favourable for formation of bidentate donor bonds.^{125,126} In addition, the lowest unoccupied π^* orbital has suitable

symmetry and energy for π -back donation, from metal d-orbitals. Several molybdenum tetracarbonyl derivatives have been prepared by a variety of routes, including direct reaction, displacement (as above) and "condensation"



[For $\text{R}' = \text{C}_6\text{H}_5$; $\text{R} = \text{OH}$. For $\text{R}' = \text{CH}_3$; $\text{R} = \text{OH}, \text{OCH}_3, \text{NH}_2, \text{N}(\text{CH}_3)_2$, alkyl, aryl]. The complexes are air stable and in reaction with other ligands e.g. PPh_3 , and I_2 , CO is displaced and the diazabutadiene ligand is retained.

Analogous chromium and tungsten derivatives have been prepared by irradiation.¹²⁵

The i.r., n.m.r. and electronic spectra of the molybdenum complexes have been studied in detail, and the bonding is described in a qualitative M.O. scheme as a σ -bond between the N-lone pair and the metal, but in addition there is back-donation from the filled metal d-orbitals into π -antibonding orbitals on the ligand.¹²⁶

Triphenylphosphinimide reacts with $\text{M}(\text{CO})_6$ ($\text{M} = \text{Mo}, \text{W}$)¹²⁷ to give either $(\text{Ph}_3\text{P}=\text{NH})_2\text{Mo}(\text{CO})_4$ or at a higher temperature $[(\text{Ph}_3\text{P}=\text{NH})_2\text{Mo}(\text{CO})_3]_2$ the latter compound having bridging carbonyl groups. Spectroscopic techniques are again used to show that $\sigma\text{N} \longrightarrow \text{M}$ bonding occurs, but also that added stability of the complexes comes from delocalisation of the charge:¹²⁷

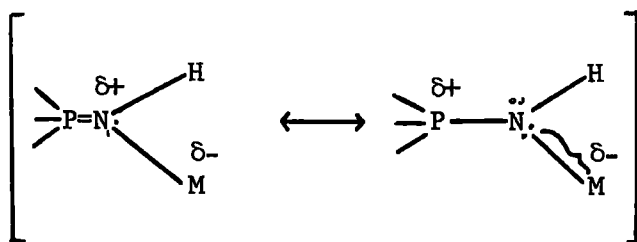

Reaction between methylmethoxycarbene-pentacarbonylchromium and hydroxylamine (dry) proceeds as shown in the equation:^{128,129}

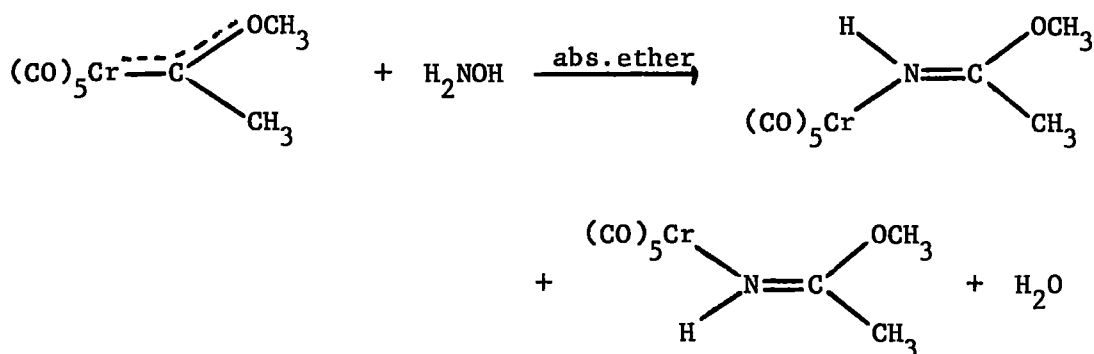

The two isomeric forms of the (methyl acetimidato) pentacarbonylchromium were separated by fractional crystallisation and were shown by variable temperature n.m.r. to be interconvertible. Reaction of the carbene with unsymmetrically substituted hydrazines, for example N,N-dimethyl hydrazine gives known nitrile chromium pentacarbonyl derivatives, perhaps by the mechanism shown:^{128,129}

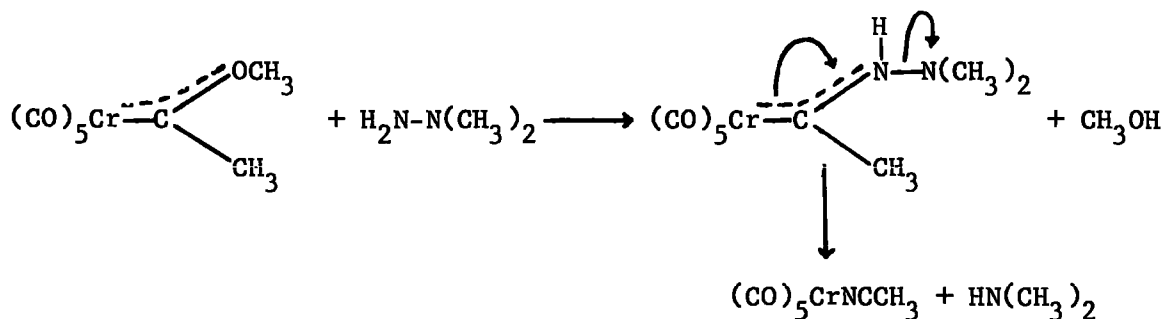

A pseudo allylic structure has been proposed for the complex $\pi\text{-CpMo(CO)}_2(\text{Ph}_2\text{CNCPh}_2)^{130}$, prepared by reaction of $\pi\text{-CpMo(CO)}_3\text{Cl}$ with 2 moles of $\text{Ph}_2\text{C=NLi}$, in which the ligand must act as a 3 electron donor.¹³⁰

King and Bisnette¹⁰⁵ have prepared a novel molybdenum compound by reaction of $[\pi\text{-CpMo(CO)}_3]_2$ with 2-chloromethylpyridine. The product contains a heterocyclic ring with the metal atom as part of the ring, as shown in Fig.

I.6.

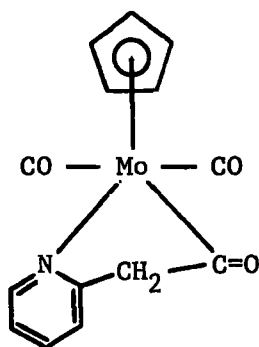

Fig. I.6.

The analogous W compound could not be prepared.¹⁰⁵

The compound N-n-butylthiopicolinamide (btp) reacts with $[\text{Mo(CO)}_4\text{X}_2]_2$

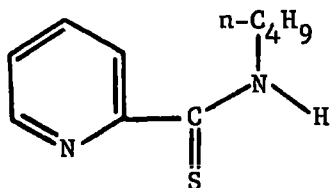
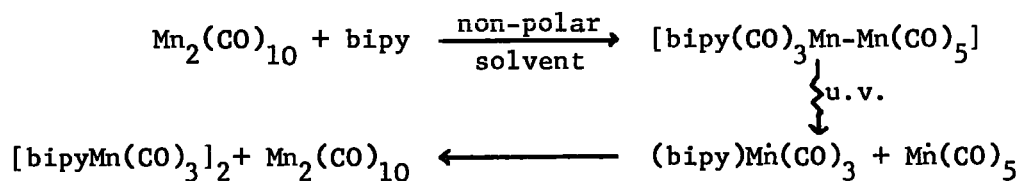

Fig. I.7.

(X = Cl, Br) to give $\text{Mo}(\text{CO})_2\text{X}_2\text{btp}_2$. (Fig.I.7). Thiopicolinamides usually behave as uni-negative bidentate ligands by loss of a proton, but in these complexes, the ligand appears to be acting as a monodentate neutral ligand, co-ordinating to the metal via the pyridine N-atom.¹³¹ The compounds $(\text{C}_5\text{H}_5)\text{Ti}(\text{NMe}_2)_3\text{M}(\text{CO})_3$ (M = Cr, Mo, W)¹³² are reported to form when $\pi\text{-CpTi}(\text{NMe}_2)_3$ and $\text{M}(\text{CO})_6$ are irradiated in cyclohexane solution. The i.r. spectra support the assignment of NMe_2 bridges, but the n.m.r. spectra cannot be interpreted on this basis.¹³²

3a. Manganese

In contrast to the Gp.VI metal carbonyls, dimanganese decacarbonyl disproportionates with most nitrogen bases with little or no π -acceptor properties, e.g. $\text{Mn}_2(\text{CO})_{10} + \text{piperidine} \xrightarrow{120^\circ} [\text{Mn}^{+\text{II}}(\text{pip})_6][\text{Mn}^{-\text{I}}(\text{CO})_5]_2$.^{133,134} However, some strong bases e.g. pyridine, aniline and o-phenylenediamine give monosubstituted derivatives $\text{Mn}(\text{CO})_4\text{L}$.¹³⁴ n-Butylamine seems unique in that it reacts at room temperature to give $[\text{Mn}^{+\text{I}}(\text{CO})_5(\text{n-C}_4\text{H}_9\text{NH}_2)][\text{Mn}^{-\text{I}}(\text{CO})_5]$.¹³⁴ With bases having π -acceptor properties, e.g. bipy, o-phen, unsymmetrically substituted dimers^{133,134,137} are obtained by reaction in non-polar solvents. Irradiation of solutions of these dimers yields paramagnetic monomers¹³³, which readily combine to give symmetrical dimers:^{133,134}



In polar solvents, bipy and o-phen cause disproportionation^{133,134} to give, for example $[\text{Mn}^{+II}(\text{o-phen})_3][\text{Mn}^{-I}(\text{CO})_5]$.

The carbonyl halide derivatives in Table I.2(ii) are in almost all cases prepared by the action of the ligand on $\text{Mn}(\text{CO})_5\text{X}$ or $[\text{Mn}(\text{CO})_4\text{X}]_2$. Monodentate, and most bidentate amines replace two CO groups to give tri-carbonyl species, but some of the pyridine-2-aldimines give bridged binuclear complexes.¹³⁸ $\text{Mn}(\text{CO})_3(\text{dien})\text{I}$ was prepared from $[(\text{mesitylene})\text{Mn}(\text{CO})_3]\text{I}$.¹⁵⁴ $\text{Mn}(\text{CO})_5\text{X}$ complexes react in a slightly different manner with liquid ammonia or ethylenediamine, to give ionic compounds.^{135,138} The kinetics of the reactions between $\text{Mn}(\text{CO})_5\text{X}$ compounds and ligands have been studied.¹⁴¹ For all nitrogen ligands studied, the reactions proceed directly to the cis-disubstituted complexes, at a rate which is independent of the ligand concentration. The rates of reaction decrease in the order $\text{Cl} > \text{Br} > \text{I}$. A dissociative (SN_1) mechanism accounts for the experimental observations.¹⁴¹

Reaction of methyl- or phenyl-manganese pentacarbonyls $[\text{RMn}(\text{CO})_5]$ with primary or secondary amines leads to acyl derivatives of the type $\text{Mn}(\text{CO})_4(\text{COR})(\text{NHR}'\text{R}'')$.¹⁴² Kinetic studies on the reaction of $\text{MeMn}(\text{CO})_5$ with cyclohexylamine and N-methylcyclohexylamine in various solvents support a mechanism of solvent assisted migration, probably of the methyl group, rather than a carbonyl group.¹⁴³ Through the use of i.r. and n.m.r. spectral techniques, Kraihanzel and Maples¹⁴⁴ studied the reactions of $\text{MeMn}(\text{CO})_5$ with alkylamines and aniline to give only cis-acetyl derivatives. These reactions do not go to completion and the products are unstable in solution.

Table I.2. Manganese Carbonyl Complexes

(i) Derivatives of $Mn_2(CO)_{10}$

<u>Type of Compound</u>	<u>L or L₂</u>	<u>Ref.</u>
$Mn(CO)_4L$	o-phenylenediamine	134
	aniline	134
	pyridine	134
$[L_2Mn(CO)_3-Mn(CO)_5]$	bipy	134
	o-phen	133, 134, 137
$[Mn(CO)_3L_2]_2$	bipy	134
	o-phen	134
$[Mn^{+I}(CO)_5L][Mn^{-I}(CO)_5]$	n-butylamine	134
$Mn(CO)_3L_2$	o-phen	133
$Mn_2(CO)_9L$	NH ₃	133
$[Mn^I(CO)_3L_3]^+X^-$ ($X^- = Mn^{-I}(CO)_5; BPh_4$)	NH ₃	135
$[Mn(CO)_4L_2]_2^+X^{2-}$ ($X^{2-} = [Zn_2Cl_6]$)	o-phen	136
$[Mn(CO)_4L_2]X^-$ ($X^- = Co(CO)_4$)	o-phen	137
$(CO)_4CoMn(CO)_3L_2$	o-phen	137

(ii) Derivatives of manganese carbonyl halides

(a) $Mn(CO)_3L_2X$

<u>X</u>	<u>L</u>	<u>Ref.</u>
I	NH ₂ (C ₆ H ₁₁)	142
Cl	aniline	145

<u>X</u>	<u>L</u>	<u>Ref.</u>
Br	aniline	29,138,141
Cl	pyridine	138,141
Br	pyridine	29,138,141
I	pyridine	138,139,141
NO ₃	pyridine	140
Br	o-ClC ₆ H ₄ NH ₂	29,141
Br	p-CH ₃ OC ₆ H ₄ NH ₂	29
Br	(CH ₃) ₂ CHNH ₂	29
Br	3-BrC ₅ H ₄ N	29
Br	4-CH ₃ C ₅ H ₄ N	29
Br	p-CH ₃ C ₆ H ₄ NH ₂	141
Br	o-CH ₃ C ₆ H ₄ NH ₂	141
Cl	NH ₃	11
Br	NH ₃	11
I	NH ₃	11

(b) Mn(CO)₃L'X

<u>X</u>	<u>L'</u>	<u>Ref.</u>
Cl	(C ₅ H ₄ N-CH=N-CH ₃)	138
Cl	(C ₅ H ₄ N-CH=N-C ₆ H ₅)	138
Cl	o-phen	133,138
Br	o-phen	138
I	o-phen	133,138
Cl	bipy	138
Br	bipy	138
I	bipy	138,139
NO ₃	bipy	140
I	diethylenetriamine(dien)	154

(c) $[\text{Mn}(\text{CO})_3\text{X}]_2\text{L}''$

<u>X</u>	<u>L''</u>	<u>Ref.</u>
C1	$(\text{C}_5\text{H}_4\text{N}-\text{CH}=\text{N}-\text{N}=\text{CH}-\text{NC}_5\text{H}_4)$	138
C1	$(\text{C}_5\text{H}_4\text{N}-\text{CH}=\text{N}-(\text{CH}_2)_2-\text{N}=\text{CH}-\text{NC}_5\text{H}_4)$	138
C1	$(\text{C}_5\text{H}_4\text{N}-\text{CH}=\text{N}-\text{C}_6\text{H}_4-\text{N}=\text{CH}-\text{NC}_5\text{H}_4)$	138

(d) Ionic derivatives

<u>Compound</u>	<u>Ref.</u>
$[\text{Mn}(\text{CO})_4(\text{NH}_3)_2]\text{Br}$	135, 138
$[\text{Mn}(\text{CO})_3(\text{NH}_3)_3]\text{Cl}$	135
$[\text{Mn}(\text{CO})_4(\text{en})]\text{Br}$	138
$[\text{Mn}(\text{CO})_3(\text{bipy})(\text{py})]\text{NO}_3$	140
$[\text{Mn}(\text{CO})_3(\text{bipy})\text{PO}_3]\text{NO}_3$	140
$[\text{Mn}(\text{CO})_2(\text{bipy})(\text{PO}_3)_2]\text{NO}_3$	140
$\text{Na}[\text{Mn}(\text{CO})_4(\text{NH}_2\text{C}_6\text{H}_{11})]$	142
$[\text{Mn}(\text{CO})_5(\text{NH}_2\text{Me})]\text{Cl}$	145
$[\text{Mn}(\text{CO})_5(\text{NH}_2\text{Me})]\text{PF}_6$	145
$[\text{Mn}(\text{CO})_5(\text{NH}_2\text{Et})]\text{Cl}$	145
$[\text{Mn}(\text{CO})_5(\text{NH}_2\text{Et})]\text{PF}_6$	145

(iii) Organo-manganese derivatives

(a) $\text{Mn}(\text{CO})_4(\text{COR})(\text{NHR}'\text{R}'')$

<u>R</u>	<u>NHR'R''</u>	<u>Ref.</u>
Me	$\text{C}_6\text{H}_{11}\text{NH}_2$	142, 143, 144
Me	NH_3	142
Me	$\text{NH}(\text{CH}_3)(\text{C}_6\text{H}_{11})$	142, 143, 144
Me	$\text{NH}_2\text{C}_6\text{H}_5$	142
Ph	$\text{NH}_2\text{C}_6\text{H}_{11}$	142
Ph	$\text{NH}_2\text{C}_6\text{H}_5$	142
Me	quinoline	194

(b) $\underline{\text{Mn}(\text{CO})_4(\text{CONHR})(\text{NH}_2\text{R})}$

<u>R</u>	<u>Ref.</u>
Me	145
Et	145
$\text{CH}(\text{CH}_3)_2$	145

(iv) π -cyclopentadienyl and related compounds

(a) $\underline{\pi\text{-CpMn}(\text{CO})_2\text{L}}$

<u>L</u>	<u>Ref.</u>
Aniline	146
Piperidine	146, 150, 151
Benzonitrile	147
Acetonitrile	147, 150
Pyridine	148, 150, 152
Piperazine	149, 150
Triethylenediamine	149
Urotropin	149, 150
NH_3	150, 151
NMe_3	150, 151
n-Propylamine	150, 151
n-Hexylamine	150, 151
Me_2NH	150, 151, 152
Pyrolidine	150, 151
2,5-Dimethylpyrolidine	150
γ -Picolin	150
Ethylamine	151

(b)	$[\pi\text{-CpMn(CO)}_2]_2\text{L}$	(c)	$(\pi\text{-CH}_3\text{C}_5\text{H}_4)\text{Mn(CO)}_2\text{L}$
	<u>L</u>		<u>L</u>
	Piperazine		Pyridine
	Triethylenediamine		Piperidine
	<u>Ref.</u>		<u>Ref.</u>
	149		148
	149		153

(v) Thiocyanate and related derivatives

(a)	$\text{Mn(CO)}_3\text{L}_2\text{NCS}$	
	<u>L</u>	<u>Ref.</u>
	(CO)	156
	Pyridine	155,156,157
	(p-CH ₃ C ₆ H ₄ NH ₂)	157
	(4-CH ₃ C ₅ H ₄ N)	155,157
	p-ClC ₆ H ₄ NH ₂)	157
	(p-FC ₆ H ₄ NH ₂)	157
	PPh ₃	155,157
	AsPh ₃	157
	SbPh ₃	157
(b)	$\text{Mn(CO)}_3\text{L}'\text{NCS}$	
	<u>L'</u>	<u>Ref.</u>
	bipy	155,157
	1,2-bis(diphenylphosphino)ethane	157

Both inductive and steric effects of the group bonded to nitrogen are influential in determining the position of equilibrium. A methyl-migration mechanism is again supported.¹⁰⁴

The carbonamido carbonyl complexes $\text{Mn}(\text{CO})_4(\text{CONHR})(\text{NH}_2\text{R})$ are prepared by the action of a large excess of an amine (MeNH_2 , EtNH_2 or $(\text{CH}_3)_2\text{CHNH}_2$) on $\text{Mn}(\text{CO})_5\text{Br}$. An X-ray analysis has verified the structure shown in Fig. I.8.

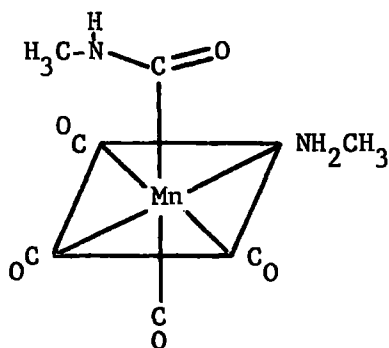
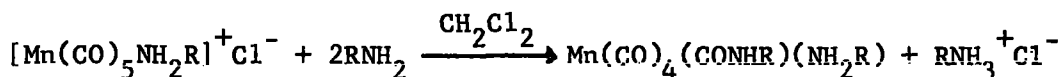

Fig. I.8.

The complexes decompose in solution to give $\text{Mn}_2(\text{CO})_{10}$ and the N-alkylformamide. Reaction with HCl yields $\text{RNH}_3^+\text{Cl}^-$ and $[\text{Mn}(\text{CO})_5\text{NH}_2\text{R}]\text{Cl}^-$, isolated as the PF_6^- salt. The carbonylate cation reacts with more amine to form the carbonamido complex again:



Strohmeier and his co-workers¹⁴⁶⁻¹⁵¹ have prepared several π -cyclopentadienyl manganese dicarbonyl derivatives by u.v. irradiation of a solution of

π -CpMn(CO)₃ and the ligand. Relatively weak bases gave isolable products, but stronger bases e.g. Et₃N gave unstable derivatives which could not be isolated.¹⁴⁶⁻¹⁵¹

The thiocyanate manganese carbonyl derivatives are of interest because of the ambident nature of the ligand. Solid Mn(CO)₅(CNS) itself contains a Mn-S bond¹⁵⁶ (in contrast to the Gp.VI metal carbonyl derivatives¹⁰⁹). I.R. spectra of the compound in solvents such as CHCl₃, C₂H₄Cl₂, CHCl₂ and ethyl acetate are consistent with an equilibrium between Mn-S and Mn-N bonded isomers. In CH₃CN, however, the i.r. indicates that the compound exists solely as the N-bonded isomer, but on evaporation of the solvent, the S-bonded isomer is recovered.¹⁵⁶ Substitution by N-ligands leads in all cases to cis-Mn(CO)₃L₂NCS complexes where the thiocyanate group is bonded to the metal via the nitrogen atom. Other ligands, such as PPh₃, AsPh₃ and SbPh₃ give S-bonded tetracarbonyl derivatives e.g. Mn(CO)₄(PPh₃)SCN, S-bonded cis-tricarbonyl derivatives (for AsPh₃ and SbPh₃) and N-bonded trans-tricarbonyl derivatives e.g. trans-[Mn(CO)₃(SbPh₃)₂NCS]. Several of these compounds can be prepared both by direct reaction of Mn(CO)₅(CNS) with the ligand, and by metatheses involving the corresponding chloro- or bromo complex and potassium thiocyanate. It is thought that the extent of M-CO π -bonding in a thiocyanate carbonyl complex may play an important role in stabilizing a given mode of metal-thiocyanate attachment. When π -bonding is relatively weak, as in Mn(CO)₅(CNS), the more polarisable sulphur end is preferred by the metal. The sulphur bonding increases negative charge on the

metal and enhances M-CO π -bonding. On substitution by ligands with less π -bonding ability than the CO groups, e.g. amines, the negative charge on the metal increases, thus increasing the M-CO π -bonding, and the metal prefers the nitrogen rather than the sulphur atom. Thus the extent of M-CO π -bonding controls the polarisability of the metal, and at some unknown, critical stage, changes the preference of the latter for one donor atom of the thiocyanate to the other. Steric factors may also play a role in stabilizing Mn-S linkage in the cis-tricarbonyls containing the bulky ligands AsPh_3 and SbPh_3 .¹⁵⁷

Two compounds of interest not included in the Tables, have been prepared by reaction of NaMn(CO)_5 with 2-chloromethyl dimethylamine and with 2-chloromethylpyridine:^{36,105}

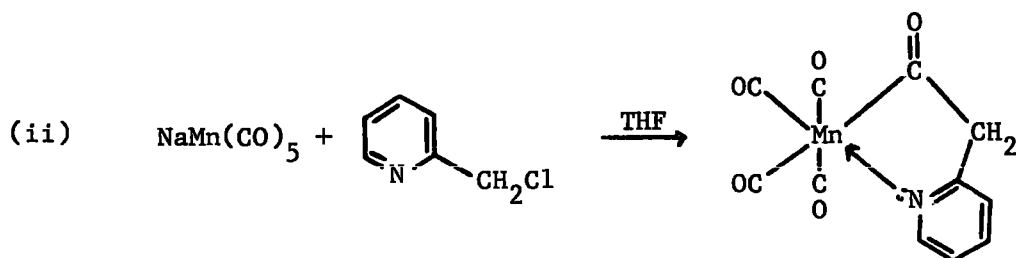
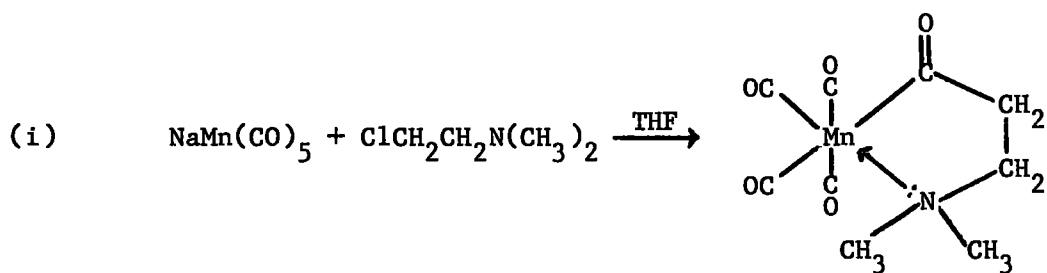

The structures of the complexes were deduced mainly from i.r. evidence, and are analogous to the Mo compound mentioned earlier.¹⁰⁵ Presumably the first step in the reaction is simple halogen displacement to give e.g.

$(\text{CH}_3)_2\text{N}(\text{CH}_2)_2\text{Mn}(\text{CO})_5$ which can then undergo intramolecular rearrangement with the nitrogen lone pair attacking the metal, and a carbonyl group inserting between the metal and the alkyl group, to give the cyclic acylheterocycle.^{105,36}

This is a similar pathway to that envisaged for the preparation of $\text{Mn}(\text{CO})_4(\text{COR})(\text{NHR}'\text{R}'')$ compounds.^{142,143,144}

3b. Rhenium and Technetium

The few reported derivatives of rhenium carbonyl, containing N-ligands, seem to indicate that the Mn and Re carbonyl systems behave fairly similarly. There is only one reported derivative of technetium carbonyl containing a nitrogen ligand, presumably because of the unavailability of the carbonyl.

The first derivatives of rhenium carbonyl itself were $\text{Re}(\text{CO})_3\text{py}_2$ and $\text{Re}(\text{CO})_3\text{o-phen}$, which were reported in 1941, and were thought to be dimers.¹⁶⁰ The carbomethoxycarbonyl compound¹⁶² was prepared by the action of MeO^- on $[\text{Re}(\text{CO})_4(\text{o-phen})]^+$, (see Table 1.3(i)):

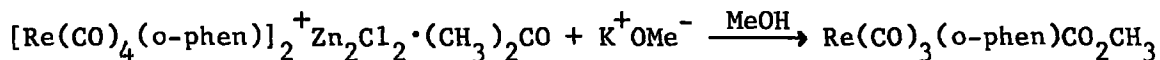

The action of HCl on this complex reverses the reaction and the cation is obtained as $[\text{Re}(\text{CO})_4\text{o-phen}]^+\text{Cl} \cdot \text{HCl}$.

Mononuclear and binuclear rhenium carbonyl halides react readily with donors to give usually, disubstituted rhenium tricarbonyl halide derivatives.

The dimeric halides often react under milder conditions than the monomers. For example, pyridine reacts with $\text{Re}(\text{CO})_5\text{I}$ during 5 hours reflux to give $\text{py}_2\text{Re}(\text{CO})_3\text{I}$ ¹³⁹, whereas the dimer $[\text{Re}(\text{CO})_4\text{I}]_2$ with pyridine gives the same product after $\frac{1}{2}$ hour.¹³⁹ However, liquid NH_3 reacts with $\text{Re}(\text{CO})_5\text{Cl}$ to give $\text{Re}(\text{CO})_4(\text{NH}_3)\text{Cl}$ and $[\text{Re}(\text{CO})_4(\text{NH}_3)_2]\text{Cl}$, the latter being isolated as the tetraphenylborate salt.¹⁵⁸ No CO is evolved during the reaction; formamide has been identified in the products, so the displaced CO must react with liquid NH_3 . Reaction of (o-phen) with $[\text{Re}(\text{CO})_4(\text{NH}_3)\text{Cl}]$ displaces NH_3 and CO to give $\text{Re}(\text{CO})_3(\text{o-phen})\text{Cl}$. $[\text{Re}(\text{CO})_4(\text{NH}_3)_2]\text{Cl}$ reacts with excess pyridine to give $\text{Re}(\text{CO})_3\text{py}_2\text{Cl}$.¹⁵⁸

Indirect synthetic methods have also been used. $[\text{Re}(\text{CO})_3\text{EPh}_2\text{X}]_2$, where $\text{E} = \text{Si}, \text{X} = \text{Cl}$ or $\text{E} = \text{Se}, \text{X} = \text{Br}$, react with donors e.g. pyrrolidine to give $\text{Re}(\text{CO})_3(\text{HNC}_4\text{H}_8)_2\text{X}$, ($\text{X} = \text{Cl}, \text{Br}$) compounds. But $[\text{Re}(\text{CO})_3\text{SePh}_2\text{I}]_2$ reacts with pyrrolidine to give the ionic complex $[\text{Re}(\text{CO})_3(\text{HNC}_4\text{H}_8)_3]\text{I}$, isolated as the tetraphenylborate salt.¹⁶¹

Kinetic studies of the reaction of the tetracarbonyl halide dimers of rhenium with the ligands pyridine, γ -picolin and α -chloropyridine have been reported.¹⁶⁴ For the first two ligands, monosubstituted complexes of the type $\text{Re}(\text{CO})_4\text{LX}$ ($\text{X} = \text{Cl}, \text{Br}, \text{I}$) were characterised. The reactions are first order in both metal carbonyl and ligand, and for the same reagent the rates decrease with changes in the halogen $\text{Cl} > \text{Br} > \text{I}$. This can be explained on the basis of different electronegativities of the halide ions; the more electronegative halide ion will reduce electron density on the metal, making

it more susceptible to nucleophilic attack. The mechanism of the reaction could involve either a rapid pre-equilibrium in solution between a di-bridged form and a single bridged species and nucleophilic attack at the vacant co-ordination site, or the formation of a 7 co-ordinate activated complex.¹⁶⁴

Monosubstituted rhenium pentacarbonyl halides $\text{Re}(\text{CO})_4\text{LX}$ have been found to react with a second ligand L' according to a first order rate equation, the rate being independent of L' , even at high concentrations.¹⁶⁵ The rate determining step appears to be dissociation of a CO group from the complex. The ligand, L , influences the rate of reaction, and N-ligands are found to have a labilizing effect on the CO groups. As explained in Section F, this is contrary to what would be predicted on π -bonding arguments and is explained in terms of stabilization of the transition state. Rhenium pentacarbonyl halides also react according to a 1st order rate equation, the rate-determining step being dissociation of a CO group. Replacement of a second CO group to give the disubstituted complex is very rapid.¹⁶³

4a. Iron

Direct reaction of $\text{Fe}(\text{CO})_5$, $\text{Fe}_2(\text{CO})_8$ or $\text{Fe}_3(\text{CO})_{12}$ with N-donor ligands usually causes disproportionation leading to complex iron cations and unsubstituted carbonyl ferrate anions. The cations usually contain 4- or 6-co-ordinate $\text{Fe}^{+\text{II}}$ but the anions can be $[\text{Fe}_3(\text{CO})_{11}]^{2-}$, $[\text{Fe}_4(\text{CO})_{13}]^{2-}$, $[\text{Fe}_2(\text{CO})_8]^{2-}$, or $[\text{Fe}(\text{CO})_4]^{2-}$.⁴ A few examples are given in the equations:

Table I.3. Rhenium and Technetium carbonyl complexes

(i) Rhenium carbonyl derivatives

<u>Compound</u>		<u>Ref.</u>
$[\text{Re}(\text{CO})_3\text{py}_2]_2$?	160
$[\text{Re}(\text{CO})_3\text{o-phen}]_2$?	160
$\text{Re}(\text{CO})_3(\text{o-phen})\text{CO}_2\text{CH}_3$		162

(ii) Carbonyl halide derivatives

(a) $\text{Re}(\text{CO})_4\text{LX}$

<u>X</u>	<u>L</u>	<u>Ref.</u>
Cl	NH_3	158
Cl	py	164
Br	py	164
I	py	164
Cl	$\gamma\text{-pic}$	164
Br	$\gamma\text{-pic}$	164
I	$\gamma\text{-pic}$	164

(b) $\text{Re}(\text{CO})_3\text{L}'_2\text{X}$

<u>X</u>	<u>L'</u>	<u>Ref.</u>
Cl	py	139, 158, 160, 161, 163
Br	py	160, 163
I	py	139, 159, 160, 165
Cl	$(\text{H}_2\text{NC}_6\text{H}_5)$	158, 161
Cl	(HNC_4H_8)	161
Br	HNC_4H_8	161
Br	$\gamma\text{-pic}$	165

(c) $\text{Re}(\text{CO})_3\text{L}''\text{X}$

<u>X</u>	<u>L''</u>	<u>Ref.</u>
Cl	o-phen	158
Br	o-phen	160
I	o-phen	160
Cl	bipy	163
Br	bipy	163
I	bipy	139

(d) Ionic Derivatives

<u>Compound</u>	<u>Ref.</u>
$[\text{Re}(\text{CO})_4(\text{NH}_3)_2]\text{Cl}$	158
$[\text{Re}(\text{CO})_4(\text{NH}_3)_2]\text{BPh}_4$	158
$[\text{Re}(\text{CO})_4(\text{o-phen})]_2\text{Zn}_2\text{Cl}_6$	136
$[\text{Re}(\text{CO})_4(\text{o-phen})]\text{Cl}\cdot\text{HCl}$	162
$[\text{Re}(\text{CO})_3(\text{HNC}_4\text{H}_8)_3]\text{I}$	161
$[\text{Re}(\text{CO})_3(\text{HNC}_4\text{H}_8)_3]\text{BPh}_4$	161

(iii) Mixed carbonyl halide derivatives

<u>Compound</u>	<u>Ref.</u>
$\text{Re}(\text{CO})_3(\text{PPh}_3)(\text{py})\text{Cl}$	165

(iv) Technetium

<u>Compound</u>	<u>Ref.</u>
$\text{Tc}(\text{CO})_3(\text{HNC}_4\text{H}_8)_2\text{Cl}$	161

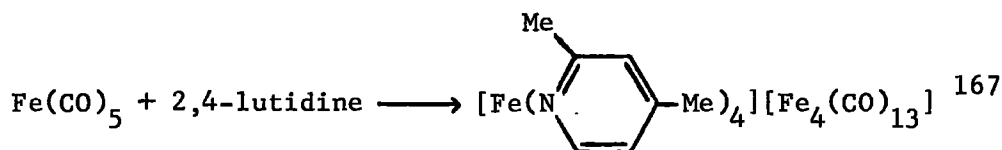
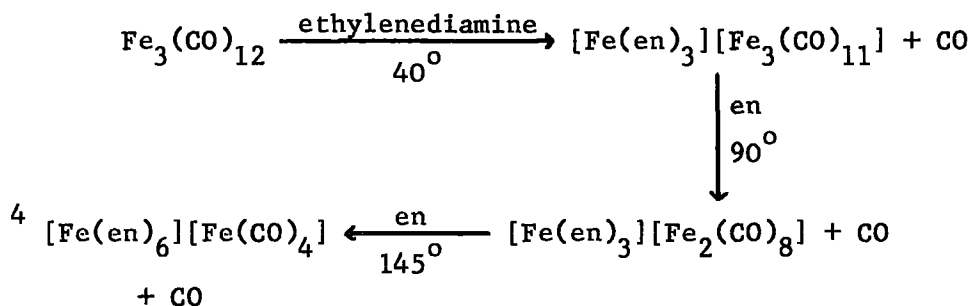
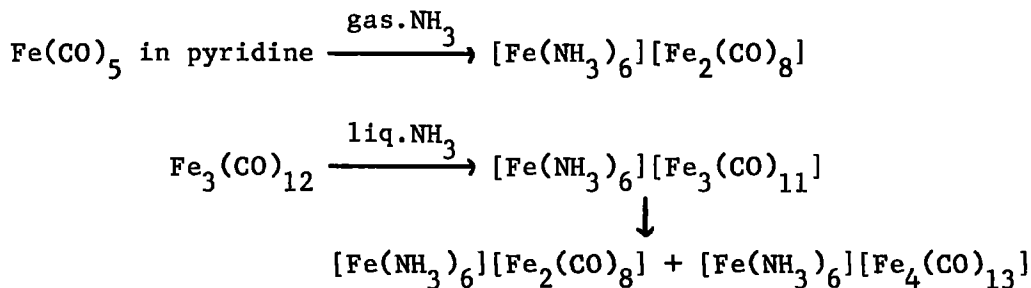

Often the primary or secondary base reacts with evolution of CO e.g. in the system $\text{Fe(CO)}_5/\text{piperidine}$, $[\text{Fe}(\text{C}_5\text{H}_{10}\text{N-CHO})_6][\text{Fe}_4(\text{CO})_{13}]$ is the product.¹⁶⁷

In some cases, intensely coloured adducts of an amine with Fe(CO)_5 have been isolated:

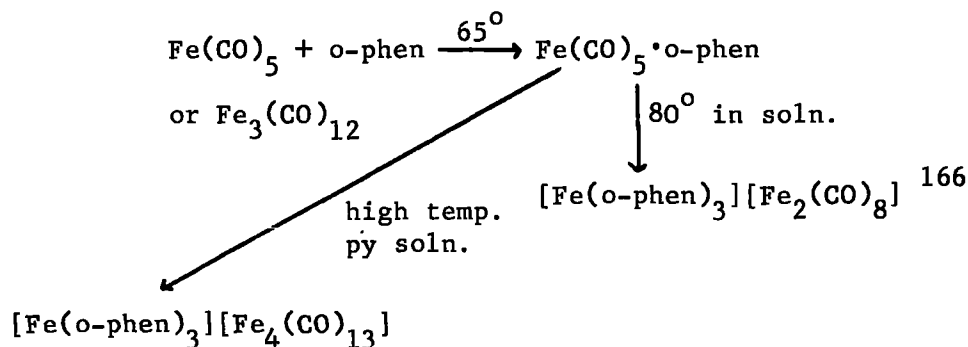

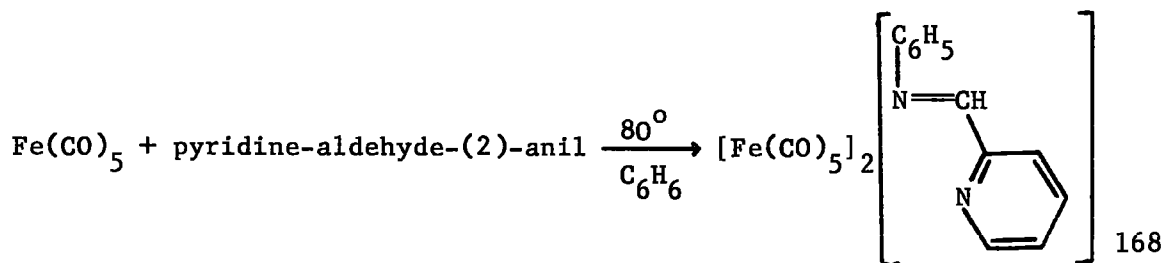
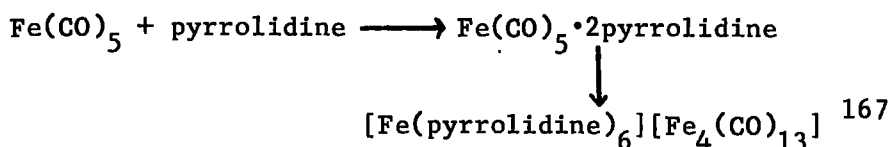
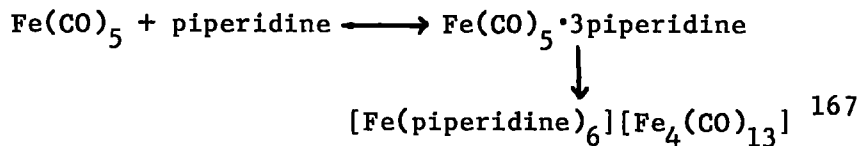

Indirect synthetic methods must be employed to prepare ironcarbonyl N-donor derivatives. Hieber and Beutner¹⁶⁹⁻¹⁷² have studied the systems $\text{Fe}(\text{CO})_4^{2-}/\text{NO}_2^-$,^{169,172} $\text{Fe}(\text{CO})_4^{2-}/\text{NH}_2\text{OH}$ ^{169,172} and $\text{Fe}(\text{CO})_4^{2-}/\text{NH}_2\text{OSO}_3^-$.^{170,171} These systems are quite complex, and a variety of products can be obtained depending upon the exact conditions. However, under certain mild conditions a small amount of a complex formulated as $[\text{Fe}(\text{CO})_3\text{NH}]_2$ precipitates from aqueous alkaline solutions as a red-orange solid. $[\text{Fe}(\text{CO})_4\text{NH}_3]$ ¹⁷¹ has been prepared by the slow addition of an alkali metal salt of hydroxylamine-O-sulphonic acid to an aqueous alkaline solution of $\text{Fe}(\text{CO})_5$ (exists as $\text{HFe}(\text{CO})_5^-$) at 0°C. The yellow crystals, of empirical formula $[\text{Fe}(\text{CO})_4\text{NH}_3]$ separate immediately and are stable only below 0°C.¹⁷¹

The complex $[\text{Fe}(\text{CO})_3\text{NH}]_2$ has been re-investigated recently and is now thought to be a bridged amino-complex rather than a bridged imino-complex, on the basis of i.r., n.m.r. and especially mass spectral evidence.^{24a}

This structure has recently been confirmed by X-ray crystallographic studies.^{24b}

A new preparative method involves irradiating a solution of $\text{Fe}(\text{CO})_5$ in aqueous KOH to which NaNO_2 has been added. Fe_2O_3 is produced, together with 9.2% of the amine.^{24a}

Reaction of triethylphosphine replaces one CO group, without disrupting the $-\text{NH}_2$ bridges, to give $[(\text{CO})_3\text{Fe}(\text{NH}_2)_2\text{Fe}(\text{CO})_2(\text{PEt}_3)]$.

The symmetrically disubstituted PPh_3 complex, $[(\text{PPh}_3)(\text{CO})_2\text{Fe}(\text{NH}_2)]_2$, is oxidised by iodine to give violet crystals of the salt

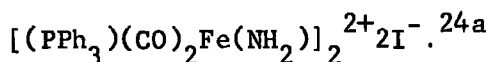

Compounds of the type $\text{Fe}(\text{CO})_2\text{L}_2\text{X}_2$ ¹⁷³ ($\text{L}_2 = \text{py}_2, \text{bipy}$; $\text{X} = \text{I}, \text{C}_3\text{F}_7$) have been prepared, as shown in the equations:

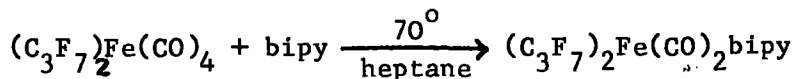
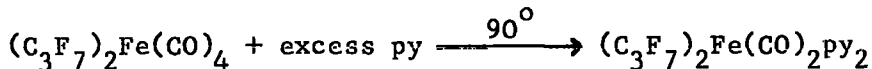
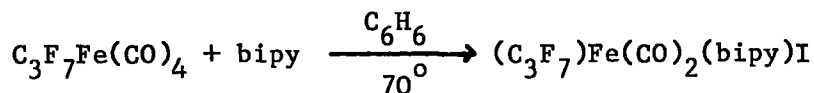
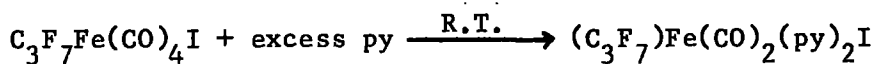

Heating the complex $(\text{C}_3\text{F}_7)\text{Fe}(\text{CO})_2(\text{py})_2\text{I}$ causes decomposition to

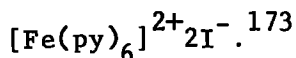

π -CpFe(CO)₂Br reacts with AlBr₃ in liquid SO₂ under rigorously dry conditions to give $[\pi$ -CpFe(CO)₂-Br-(CO)₂Fe π -Cp]⁺, isolated as the PF₆ salt.¹⁷⁴ Reactions of this salt with N-ligands, L gives the complexes $[\pi$ -CpFe(CO)₂L]PF₆, where L = pyridine, benzonitrile and aniline¹⁷⁴, which cannot be prepared by direct reaction of L with $[\pi$ -CpFe(CO)₂Br].

π -bonded pyrrolyl derivatives of manganese have been prepared by the action of pyrrole itself on Mn₂(CO)₁₀^{175,176} and by reaction of the potassium salt of pyrrole with Mn(CO)₅Br.¹⁷⁶ The second method was extended to π -CpFe(CO)₂I, which reacts with pyrrolylpotassium to give azaferrocene (π -C₅H₅Fe π -C₄H₄N).¹⁷⁶ σ -bonded intermediates may be postulated in each case, and the derivatives in Fig.I.9 have since been isolated for the iron system²³ by the reaction of π -CpFe(CO)₂I with the appropriate potassium salt under mild conditions.

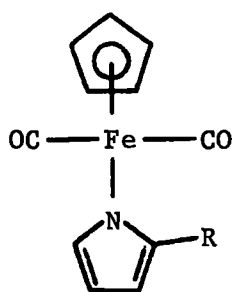

R = H, (pyrrolyl)

R = COCH₃ (2-acetylpyrrol-1-yl)

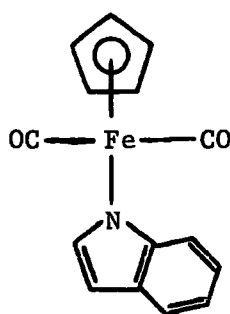

indole

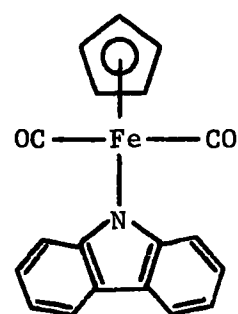

carbazole

Also 1,2,3,4,-tetrahydro derivative

Fig.I.9.

Heating the σ -pyrrolyl and indole compounds causes loss of CO and formation of the corresponding π -bonded complexes, though the π -indoles are unstable and have not been fully characterised.²³

King and Bisnette¹⁰⁵ have prepared an acylheterocyclic compound of $[\pi\text{-CpFe(CO)}_2]_2$, analogous to the manganese carbonyl and cyclopentadienyl-molybdenum carbonyl derivatives described earlier.¹⁰⁵ Reaction of $\text{NaFe(CO)}_2\pi\text{-Cp}$ and $\text{ClCH}_2\text{CH}_2\text{NMe}_2$ gave the cyclic acyl derivative (Fig.I.10a) only as a minor product.

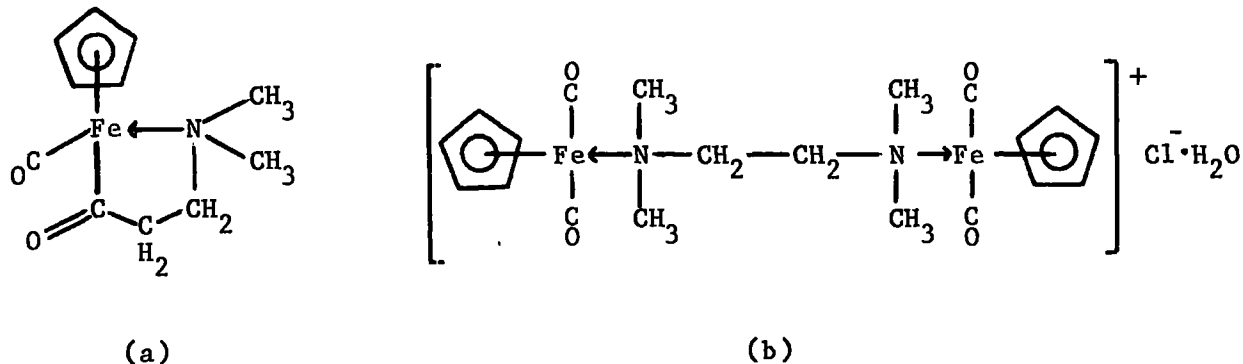

Fig.I.10.

The major product was an ionic derivative, given the formulation shown in Fig.I.10b. However, reaction of $\text{NaFe(CO)}_2\pi\text{-Cp}$ with 2-chloroethylpiperidine, and 2-chloromethylpyridine gave $\text{C}_5\text{H}_{10}\text{NCH}_2\text{CH}_2\text{Fe(CO)}_2\pi\text{-Cp}$ and $\text{NC}_5\text{H}_4\text{CH}_2\text{Fe(CO)}_2\pi\text{-Cp}$, respectively, which contain only $\sigma\text{-C-Fe}$ bonds, in contrast to the $\pi\text{-CpMo}$ and Mn derivatives.¹⁰⁵

The thiocyanate iron carbonyl derivative $[\text{Fe(CO)}_4\text{NCS}]^-$ has been isolated as its $(\text{Ph}_3\text{P})_2\text{N}^+$ salt.¹¹⁷ The thiocyanate group is nitrogen bonded and no

isomerisation was observed. Both the S-bonded and N-bonded isomers of $\pi\text{-CpFe(CO)}_2(\text{CNS})$ were prepared by the action of HPF_6 and KSCN on $[\pi\text{-CpFe(CO)}_2]_2$.¹¹⁸ No reaction occurred with the halides $\pi\text{-CpFe(CO)}_2\text{X}$. The S-bonded isomer, when warmed gently either in the solid state or in suspension in e.g. Nujol, isomerises to the N-bonded isomer, but in solution, it decomposes.¹¹⁸

Recently, there has been much interest in reactions between iron carbonyls and compounds containing nitrogen atoms in unsaturated systems. Many of the products have unusual structures, which have been elucidated by X-ray methods. Manuel^{11,177} isolated a complex from the reaction between phenyl isocyanate and $\text{Fe}_3(\text{CO})_{12}$ which he formulated as $[\text{Fe(CO)}_3\text{C}_6\text{H}_5\text{NCO}]_2$. The same complex was prepared by the treatment of $\text{Fe}_3(\text{CO})_{12}$ with azido benzene $\text{C}_6\text{H}_5\text{N}_3$, and the analogous butylisocyanate complex was also prepared.¹⁷⁷ The structure of the complex was thought to be:

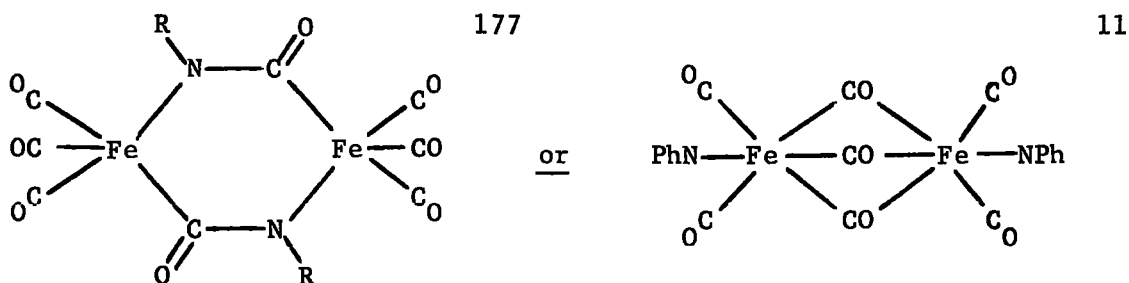

Pauson et al have recently re-examined the $\text{Fe}_3(\text{CO})_{12}/\text{PhNCO}$ reaction, and have also made the ethylisocyanate derivative. They formulate the complexes as $(\text{RN})_2\text{Fe}_2(\text{CO})_7$ from analytical and mass spectral data. Mossbauer spectroscopy shows that the iron atoms are equivalent,¹⁷⁸ and an X-ray study has

confirmed the structure I.11a for the complex, μ -diphenylureylene-bis-(tricarbonyliron).^{179,180} The complex contains two $\text{Fe}(\text{CO})_3$ units bridged by two nitrogens and thus resembles other complexes mentioned below.

Irradiation of diaryldiazomethanes with $\text{Fe}(\text{CO})_5$ gives products containing nitrogen and not products derived from the diarylcarbenes, expected as intermediates.¹⁸¹ The same products are obtained by a thermal reaction using $\text{Fe}_3(\text{CO})_{12}$.¹⁸¹ Both diphenyl- and di-p-tolyl-diazo-methanes gave black complexes (A and A', respectively) and orange complexes (B and B', respectively).¹⁸¹ Mass and n.m.r. spectra of B and B' showed these complexes to have the formulation $[\text{R}_2\text{CHN}_2\text{Fe}(\text{CO})_3]_2$ and an X-ray structural examination of B' showed the complex to be bis-(μ -4,4'-dimethylbenzophenonehydrazonato-tricarbonyliron), with the structure shown in Fig.I.11b. Again, two $\text{Fe}(\text{CO})_3$ units are bridged by two N atoms and, as observed in related compounds, the Fe-Fe distance is short. The N atoms are sp^3 hybridised, the Fe-N bonds being essentially single. The crystal structure of one of the black, involatile complexes, A, obtained in greater yield in the reaction, has also been determined¹⁸² and is shown in Fig.I.11c. The complex, $(\text{Ph}_2\text{C}=\text{N}-\text{N})_2[\text{Fe}(\text{CO})_3]_3$ is the first compound with a nitrogen atom simultaneously and equally bridging three metal atoms, and can be regarded as a bridging hydrazone complex in which both terminal hydrogens have been replaced.¹⁸² In the orange complex, only 1 terminal hydrogen had been replaced. Two Fe-Fe distances are much shorter than the third and bond lengths indicate single N-N and double C=N bonds.¹⁸²

Fig.I.11.

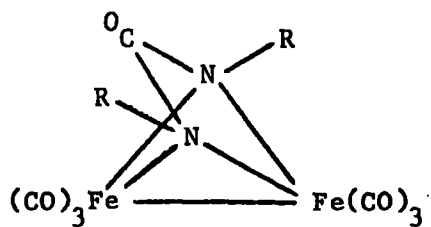

R = Ph 178,179,180,186

μ -Diphenylureylene-bis(tricarbonyliron)

R = Me 186,186a

(a)

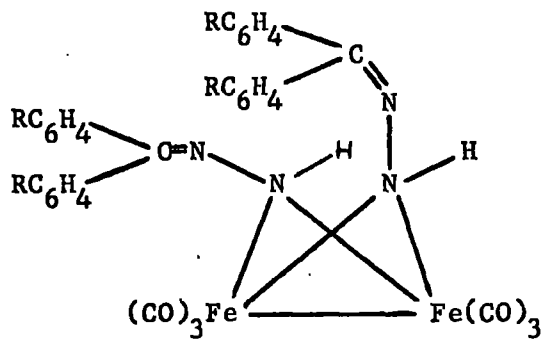

R = H (B) 181

R = p-Me (B') 181

bis(μ -4,4'-dimethylbenzophenone
hydrazonatotricarbonyliron)

(b)

Fig. I.11.

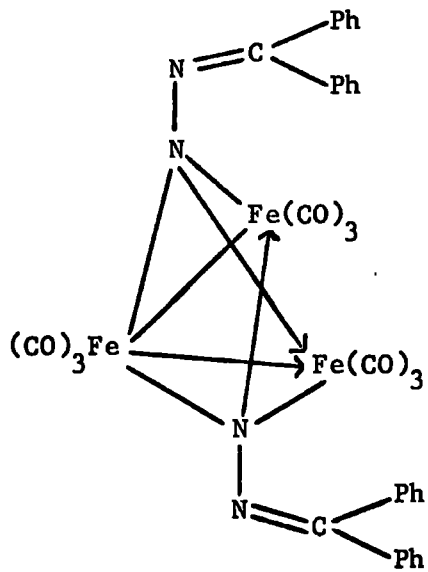

182

(c)

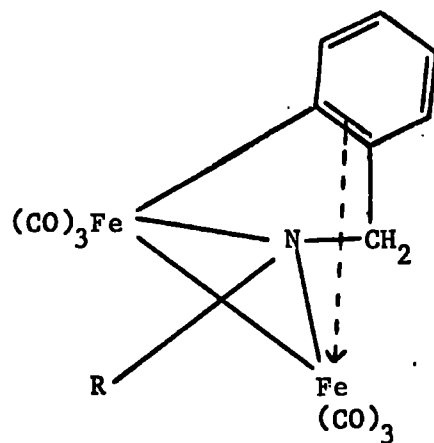

R = p-MeC₆H₄ 183

(d)

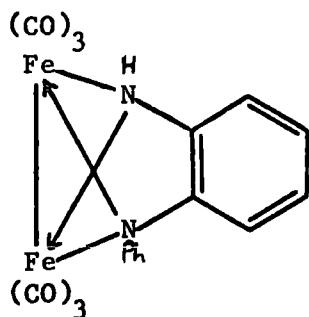

μ -N,N'-dehydrosemidinato

bis(tricarbonyliron)^{183,184}

(e)

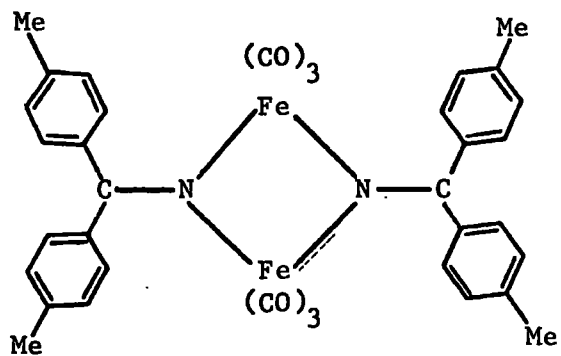

di- μ (4,4'-dimethylbenzophenoniminato)bis(tricarbonyliron)¹⁸⁵

(f)

Fig. I.11.

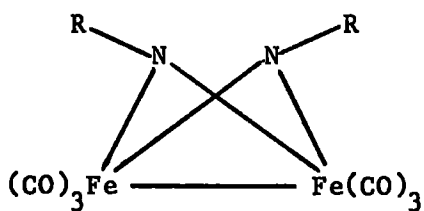

R = Ph ¹⁸⁶

(g)

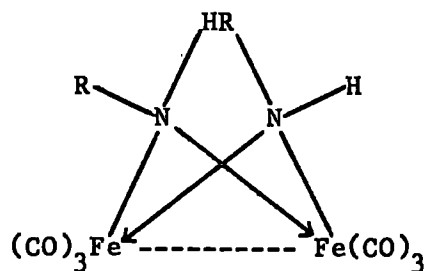

R = Ph

bis(μ -phenylamidotricarbonyl-iron)¹⁸⁶

R = Me ¹⁸⁶

(h)

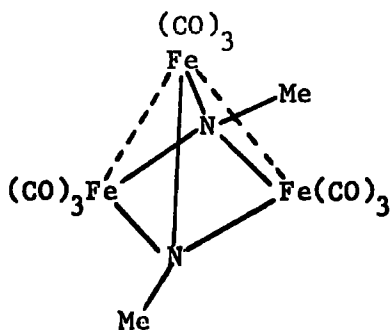

186, 186b

(i)

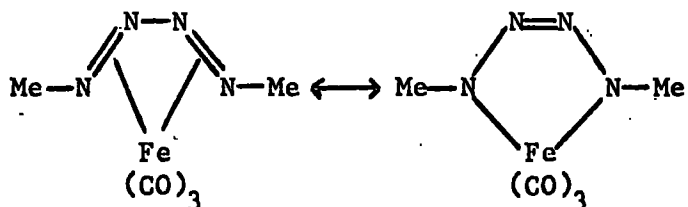

(i)

(ii)

186

(j)

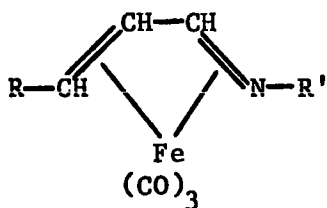

(i) R = R' = Ph ^{25, 187}

(ii) R = CH₃; R' = n-C₄H₉ ²⁵

(k)

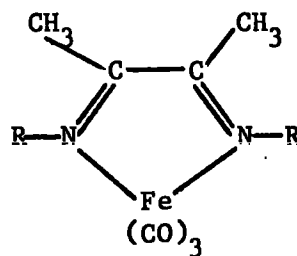

(i) R = C₆H₅ ²⁵

(ii) R = n-C₄H₉ ²⁵

(l)

Fig. I.11.

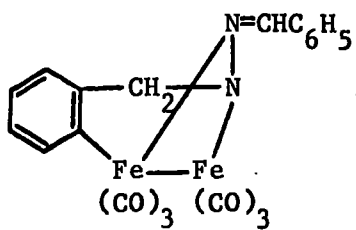

25

(m)

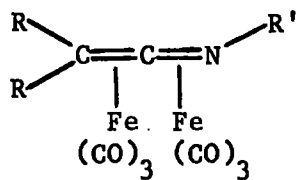

(i) $R = R' = Ph$ 188

(ii) $R = Ph; R' = Me$ 188

(n)

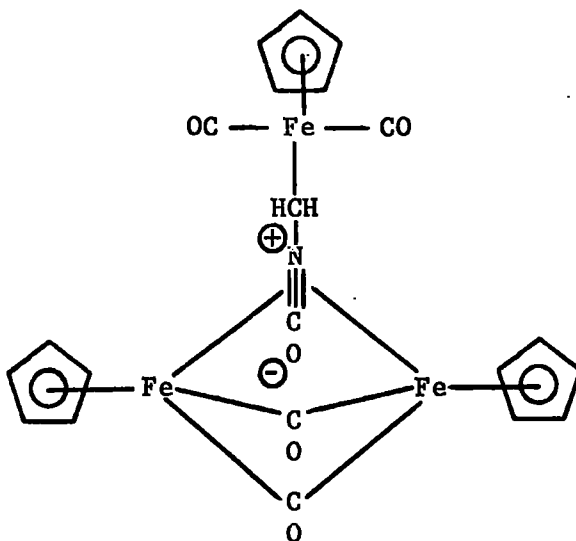

189

(o)

Fig.I.11.

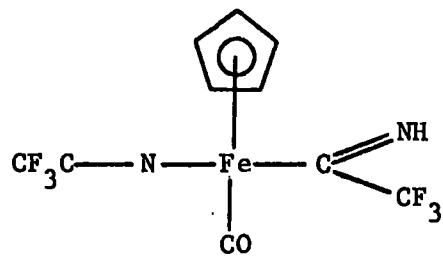

190

(p)

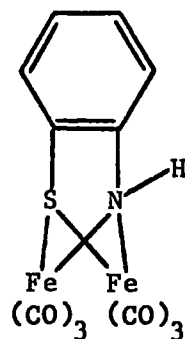

191

(q)

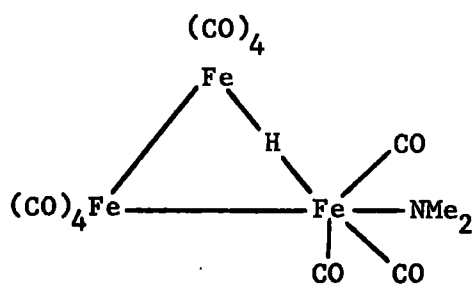

(i)

or

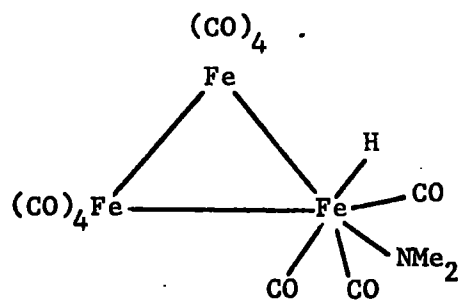

(ii)

192

(r)

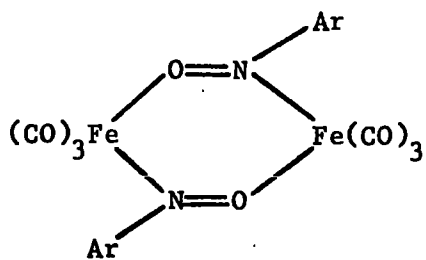

193, 194

(s)

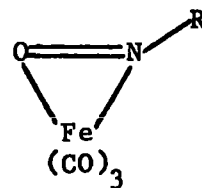

194

(t)

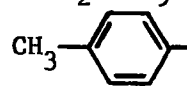
Reaction of Schiff bases with $\text{Fe}_2(\text{CO})_9$ produces $\text{Fe}_2(\text{CO})_6\text{L}$ complexes.¹⁸³ The complex formed with the base CH_3 -- $\text{N}=\text{CHPh}$ (prepared from p-toluidine and benzaldehyde) has been shown by X-ray crystallographic techniques to have the structure I.11d. Again two $\text{Fe}(\text{CO})_3$ units are bridged by a nitrogen atom. One Fe atom is part of a 5-membered ring which includes the N-atom and one side of the benzene ring. The other Fe atom is considered to π -bond to one of the olefinic bonds in the benzene ring. Again, a short Fe-Fe distance is observed and the nitrogen is considered to be a 3-electron donor.¹⁸³ The complex formed from the reaction of $\text{Fe}_2(\text{CO})_9$ with azobenzene ($\text{Ph}-\text{N}=\text{N}-\text{Ph}$) has a different structure, shown in Fig.I.11e, in which both nitrogens bridge the two $\text{Fe}(\text{CO})_3$ units, which are arranged in an eclipsed configuration.^{183,184} The Fe-Fe distance is very short. Thus formation of the complex involves rupture of the $-\text{N}=\text{N}-$ bond with rearrangement to form the o-semidine skeleton. A 36 electron structure can be rationalised on the supposition that each nitrogen acts as a three electron donor.^{183,184} The benzene rings are not involved in bonding to the metal atoms in this complex.

In the reaction of 4,4'-dimethylbenzophenoneazine, $(p\text{-Me-C}_6\text{H}_4)_2\text{C}=\text{N}=\text{N}=\text{C}(p\text{-MeC}_6\text{H}_4)_2$, with $\text{Fe}(\text{CO})_5$, rupture of the $=\text{N}-\text{N}=\text{C}$ bond occurs to give the complex $[(p\text{-MeC}_6\text{H}_4)_2\text{C}=\text{N}-\text{Fe}(\text{CO})_3]_2$, whose structure is shown in Fig. I.11f.¹⁸⁵ Splitting of the N-N bond also occurs in reaction of azo-benzene with $\text{Fe}_2(\text{CO})_9$, but, whereas in that case rearrangement to the o-semidine skeleton occurs, here the moieties are trapped in the complex separately.

Again a short Fe-Fe distance is observed, as in all nitrogen bridged iron carbonyl derivatives. The relatively short Fe-N distance allows the assumption of sp^2 hybridised nitrogen atoms, each of which acts as a 3 electron donor.¹⁸⁵

Dekker and Knox have studied the decomposition of azido-benzene, catalysed by $Fe_2(CO)_9$.¹⁸⁶ Thermal decompositions of many azido-compounds in inert media are very slow processes even at high temperatures, but the catalysed reactions occur rapidly under mild conditions. Azidobenzene and $Fe_2(CO)_9$ react rapidly at room temperature in benzene solution. Very little azobenzene is produced, the principle product being $(PhN)_2Fe_2(CO)_6$, which is assigned structure I.11g, on the basis of mass, n.m.r., i.r. and Mossbauer spectroscopy. Spontaneous decomposition of I.11g in solution gives I.11a, μ -diphenylureylene-bis(tricarbonyliron). Manuel¹⁷⁷ reported the compound $[Fe(CO)_3C_6H_5NCO]_2$ formed from azidobenzene and $Fe_3(CO)_{12}$, but his product was later shown to be I.11a, (R = Ph).^{178,179} Also formed during the catalysed decomposition of azidobenzene is the complex $(PhNH)_2Fe_2(CO)_6$, assigned the structure I.11h and obtained only in low yield in one of its expected isomeric forms - probably the "semi-trans" configuration shown.¹⁸⁶ Addition of $Fe_3(CO)_{12}$ to a benzene solution of azidobenzene causes very rapid decomposition, with the formation of significant amounts of azobenzene and azoxybenzene.¹⁸⁶ An extensive range of complexes is obtained from methylazide and $Fe_2(CO)_9$; $(CH_3N)_2Fe_3(CO)_9$ is assigned structure I.11i by analogy with $S_2Fe_3(CO)_9$ ¹⁸⁶ and other minor products include isomeric forms of μ -methyl-amido complex I.11h, (R = Me). The major product of the reaction is

I.11a (R = Me), better obtained from methylisocyanate and $\text{Fe}_2(\text{CO})_9$ ¹⁸⁶, and the structure of this complex has recently been confirmed by X-ray crystallographic studies.^{186a} A compound $\text{Me}_2\text{N}_4\text{Fe}(\text{CO})_3$ was also obtained, which is assigned structure I.11j on i.r., n.m.r. and mass spectral data.¹⁸⁶ The trinuclear species I.11i is also obtained from the violent reaction of CH_3NO_2 with $\text{Fe}_2(\text{CO})_9$ ¹⁸⁶, I.11a (R = Me) and I.11h (R = Me) being minor products. The reaction is notable for the reduction of a nitro compound by a carbonyl. The structure of the trinuclear species, I.11i, has been confirmed by X-ray crystallographic studies.^{186b}

Each of the above reactions involving azido-, isocyanate, and nitro-compounds is indicative of a catalytic generation of nitrenes and the nature of the products strongly suggests triplet nitrene. The scheme below can account for the formation of the products.

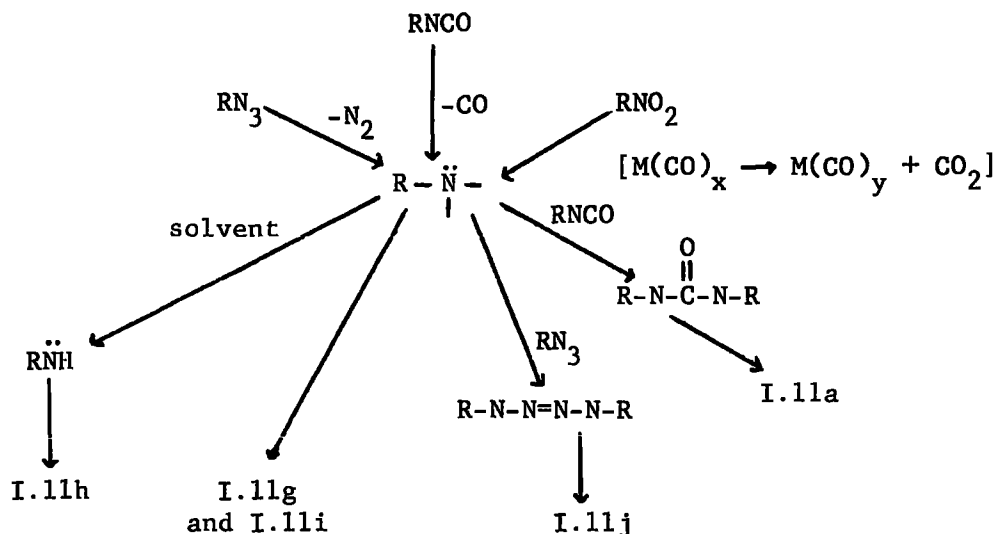

Studies of azo-methine analogues of 1,3-dienes in their reactions with iron carbonyls have been undertaken²⁵ to investigate the bonding between the metal and the ligand. Three unsaturated systems were studied: -CH=CH-CH=N- (e.g. cinnamaldehydeanil and crotonaldehyde-n-butylamine), -N=CR-CR=N- (e.g. diacetylanil and diacetyl-n-butylimine), and -CH=N-N=CH- (e.g. benzalazine and acetalazine).²⁵ $\text{Fe}_2(\text{CO})_9$ and $\text{Fe}_3(\text{CO})_{12}$ both reacted with cinnamaldehydeanil to give $(\text{PhCH}=\text{CH}-\text{CH}=\text{NPh})\text{Fe}(\text{CO})_3$ which has the structure I.11k(i). $\text{Fe}_2(\text{CO})_9$ with crotonaldehyde-n-butylimine gave the analogous compound I.11k(ii), which is an air-sensitive liquid. Reaction with PPh_3 displaced one CO group in I.11k(ii), but displaced the ligand in I.11k(i). I.11k(i) can also be prepared from $(\text{cinnamaldehyde})\text{Fe}(\text{CO})_4$ and aniline. Diacetylanil and diacetyl-n-butylimine both reacted with $\text{Fe}_2(\text{CO})_9$ to give the compounds I.11l(i) and I.11l(ii), respectively. Benzalazine and $\text{Fe}_2(\text{CO})_9$ gave $(\text{PhCH}=\text{N}-\text{N}=\text{CHPh})\text{Fe}_2(\text{CO})_6$, I.11m, but acetalazine gave a very unstable product. The structure shown for I.11m is very tentative. I.R. and n.m.r. evidence is the basis for the structural assignments²⁵, but an X-ray structural study¹⁸⁷ on I.11k(i), has confirmed that the bonding is similar to that found in conjugated di-olefin complexes, and that the nitrogen lone pair does not play a significant part in the bonding.¹⁸⁷

A related type of complex contains the $\text{>C}=\text{C}=\text{N}-$ skeleton.¹⁸⁸ N-phenyldiphenylketenimine and N-methyldiphenylketenimine react with $\text{Fe}_3(\text{CO})_{12}$ to produce the compounds $[(\text{Ph}_2\text{C}=\text{C}=\text{N}-\text{R})\text{Fe}_2(\text{CO})_6]$, where R = Ph and R = Me, respectively. Triphenylphosphine displaces one CO group from each

complex, rather than the ligand. The structures of the complexes, shown in I.11n(i) and (ii), are based on i.r. and n.m.r. evidence, and assume participation of both C=C and C=N double bonds.

Reaction between $\text{Na}[\pi\text{-CpFe}(\text{CO})_2]$ and chloromethylisocyanate gives a mixture of products, from which a small amount of material, corresponding to $(\pi\text{-Cp})_3\text{Fe}_3(\text{CO})_4(\text{CH}_2\text{NCO})$, may be isolated.¹⁸⁹ On the basis of i.r. and n.m.r. spectra data, King and Bisnette¹⁸⁹ have suggested the novel structure I.11o. In the indicated dipolar resonance structure of the NCO group, the carbon-nitrogen triple bond is isoelectronic with the carbon-carbon triple bond in acetylenes, which is known to bridge in this manner.¹⁸⁹

Trifluorophosphine is analogous to CO in its π -acceptor properties and recently trifluoroacetonitrile has been studied for the same reason.¹⁹⁰ CF_3CN and $\text{CH}_3\text{Fe}(\text{CO})_2\pi\text{-Cp}$ react to give $\text{CF}_3\text{C}(\text{NH})\text{Fe}(\text{CO})(\text{NCCF}_3)\pi\text{-Cp}$. The "extra" proton on the nitrogen is observed in the n.m.r. ^{19}F n.m.r. and mass spectral evidence indicate the structure I.11p and the high carbonyl absorption in the i.r. spectrum indicates the strong π -acceptor properties of the $\text{CF}_3\text{C}=\text{N}$ group.¹⁹⁰

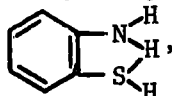
A compound $\text{Fe}_2(\text{CO})_6\text{C}_6\text{H}_4\text{SNH}$ ¹⁹¹, isolated from the reaction of o-amino-benzenethiol, , with $\text{Fe}_3(\text{CO})_{12}$, is supposed to contain two

$\text{Fe}(\text{CO})_3$ units bridged by both a sulphur and a nitrogen atom (structure I.11q).¹⁹¹

Reaction between $\text{Fe}_3(\text{CO})_{12}$ and $\text{C}_6\text{H}_5\text{C}(=\text{O})\text{Cl}$ in dimethyl formamide leads to a compound $\text{HFe}_3(\text{CO})_{11}\text{NMe}_2$ ¹⁹² in which H and NMe_2 have been incorporated into the $\text{Fe}_3(\text{CO})_{12}$ structure with loss of one CO group. The

structure of the complex is thought to be either I.11r(i) or I.11r(ii).¹⁹²

Studies of organonitrile/iron carbonyl systems have shown that heating $\text{Fe}_2(\text{CO})_9$ and PhNO_2 gives the corresponding organonitroso ironcarbonyl derivative $[\text{PhNOFe}(\text{CO})_3]_2$.¹⁹³ Irradiation with a ^{60}Co source, of an acetone solution of $\text{Fe}(\text{CO})_5$ and PhNO_2 gives the same product, whereas similar treatment of $\text{Fe}(\text{CO})_5$ with PhNO itself gives no organo-ironcarbonyl derivatives. The i.r. of the dimeric compound shows no bridging CO groups, and the structure I.11s is proposed. The reaction is thought to proceed via initial formation of a nitrobenzene iron tetracarbonyl complex, $\text{PhNO}_2\text{Fe}(\text{CO})_4$, which is reduced by CO to the dimeric nitroso-complex. A similar reaction path was proposed for the formation of $[\text{Fe}(\text{CO})_3\text{NO}]^-$ from $[\text{Fe}(\text{CO})_4(\text{NO}_2)]^-$.¹⁷² Studies on the effect of substituents in the benzene ring of nitrobenzene have shown that electron donating groups in o- or p-positions encourage the formation of monomeric nitroso-compounds, $(\text{X}-\text{C}_6\text{H}_4\text{NO})\text{Fe}(\text{CO})_3$,¹⁹⁴ with the structure I.11t. Reaction of the dimeric compound with aniline in methanol/glacial acetic acid gives azobenzene, p-toluidine gives 4-methylazobenzene.^{193,194} This type of complex may serve as a stable source of nitroso compounds. Triphenylphosphine displaces a CO group from the dimer, giving monomeric $\text{PhNOFe}(\text{CO})_2\text{PPh}_3$.³⁶

Although it has long been known that amines usually cause disproportionation of iron carbonyls, recent studies of these, and related systems¹⁹⁵⁻¹⁹⁹, have provided some insight into the mechanisms of these reactions. 2,2',2''-Tripyridyl (tripy) displaces the cyclopentadienyl group from

$[\pi\text{-CpFe(CO)}_2]_2$ to give $\text{Fe(CO)}_2\text{tripy.}$ ¹⁹⁵ The action of primary and secondary amines on $[\pi\text{-CpFe(CO)}_2\text{L}]^+$ (L = CO, PPh_3) gives carboxamido complexes of the type $\pi\text{-CpFe(CO)L(CONHR)}$. The reaction is thought to proceed via initial attack by the nitrogen lone pair on the C atom of one of the carbonyl groups, followed by proton loss.¹⁹⁶

Edgell and his co-workers¹⁹⁷⁻¹⁹⁸ have made a careful study of the initial stages of reaction between Fe(CO)_5 and n-butylamine¹⁹⁷, piperidine¹⁹⁷ and pyrrolidine¹⁹⁸, using i.r.^{197,198}, n.m.r.¹⁹⁸ and conductivity^{197,198} techniques. During the reaction 3 carbonyl species were observed, A, B and C. In the case of piperidine, A was formulated as $\text{Fe(CO)}_5(\text{NHC}_5\text{H}_{10})_3$, B was the anion HFe(CO)_4^- and C was $\text{C}_5\text{H}_{10}\text{NHFe(CO)}_4$. For pyrrolidine, compound A was isolated and shown to be $\text{Fe(CO)}_5(\text{C}_4\text{H}_9\text{N})_2$, previously prepared by Hieber.¹⁶⁷ The compound is ionic in nature and the ligand contains an amide linkage >NCO- . Thus the amine has attacked the carbon atom of a carbonyl group.¹⁹⁸ HFe(CO)_4^- is formed from water in the amine - more rigorous drying resulted in no HFe(CO)_4^- being formed. The authors¹⁹⁷ postulate the following mechanism for the room temperature reaction of amines with Fe(CO)_5 :

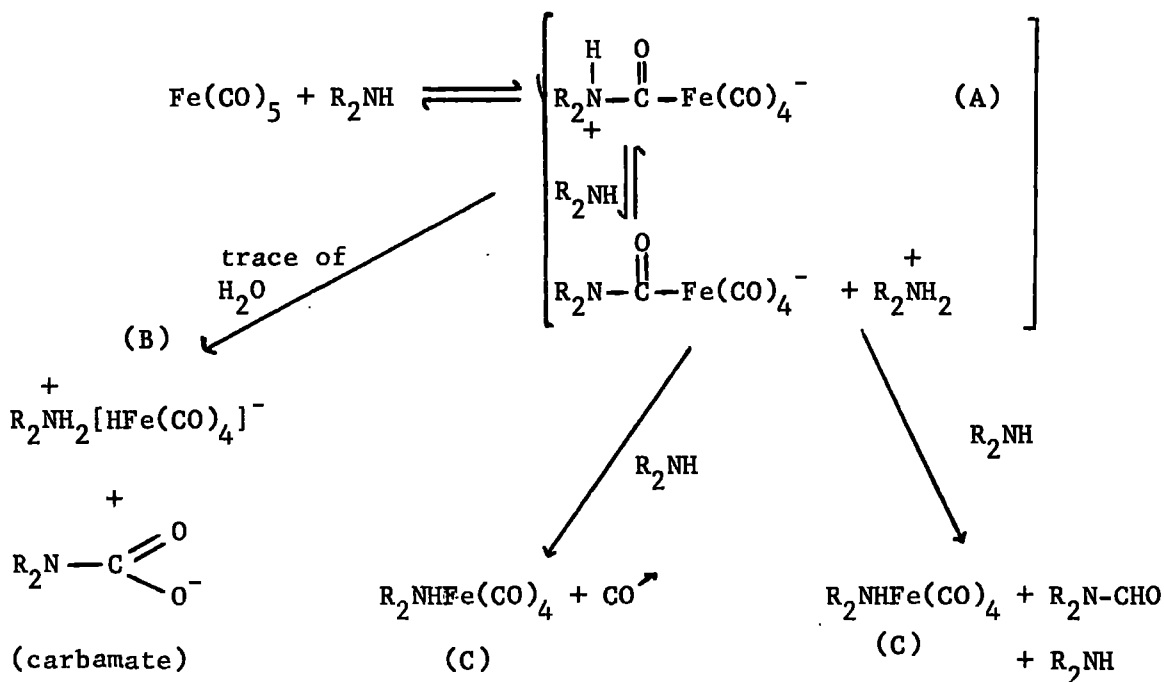

Bulkin and Lynch¹⁹⁹ have attempted to confirm the identity of species C, by reacting (olefine)Fe(CO)₄ complexes with pyrrolidine. An intermediate was formed immediately, which was slowly converted into a species with an i.r. spectrum identical to Edgell's compound C.¹⁹⁸ Fe₂(CO)₉ and pyrrolidine reacted immediately to give the same compound:

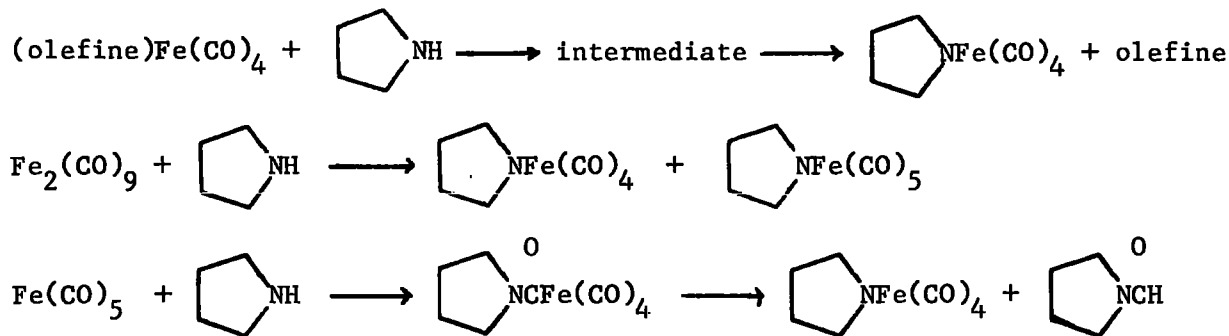

All attempts to isolate the products, however, led to decomposition.¹⁹⁹

4b. Ruthenium and Osmium

The simple carbonyls of ruthenium and osmium have not been reported to combine with nitrogen ligands, but several organonitrogen carbonyl halide derivatives are known. $[\text{Ru}(\text{CO})_2\text{I}_2]_n$ is a polymeric material, but it will react with liquid ammonia and other nitrogen-ligands at higher temperatures to give the complexes $\text{Ru}(\text{CO})_2\text{I}_2\text{L}_2$, where $\text{L} = \text{NH}_3$, pyridine, aniline, p-toluidine, acetonitrile, and where $\text{L}_2 = \text{bipyridyl}$.²⁰⁰ Hieber and Hensinger²⁰¹, in addition to the py, bipy and NH_3 derivatives, prepared $\text{Ru}(\text{CO})_2\text{I}_2\text{en}$ by condensing ethylenediamine onto $[\text{Ru}(\text{CO})_2\text{I}_2]_n$. The NH_3 and ethylenediamine compounds are unstable in solution, above -30°C and 20°C respectively. The analogous osmium compound $\text{Os}(\text{CO})_2\text{I}_2\text{py}_2$ has been prepared from $[\text{Os}(\text{CO})_2\text{I}_2]_2$ and excess pyridine.²⁰²

The ruthenium carbonyl chloride dimer $[\text{Ru}(\text{CO})_3\text{Cl}_2]_2$ was obtained by the action of CO (at 10 atmospheres pressure) on a methanolic solution of $\text{RuCl}_3 \cdot 3\text{H}_2\text{O}$.²⁰³ The carbonyl was isolated initially as the THF adduct $(\text{C}_4\text{H}_8\text{O})\text{Ru}(\text{CO})_3\text{Cl}_2$ and reaction of this with py or bipy in THF gives $\text{py}_2\text{Ru}(\text{CO})_2\text{Cl}_2$ and bipy $\text{Ru}(\text{CO})_2\text{Cl}_2$ respectively.²⁰³ Wilkinson and co-workers²⁰⁴ obtained a deep red solution of $[\text{Ru}(\text{CO})_3\text{Cl}]_2$ by the action of CO on an ethanolic solution of $\text{RuCl}_3 \cdot n\text{H}_2\text{O}$. They did not isolate the complex, however, but added an ethanolic solution of the appropriate amine to give the complexes $\text{Ru}(\text{CO})_2\text{Cl}_2\text{L}_2$ where $\text{L} = \text{C}_6\text{H}_5\text{NH}_2$, $\text{C}_6\text{H}_5\text{CH}_2\text{NH}_2$ and $\text{L}_2 = \text{bipy}$, o-phen. $\text{RuCl}_3 \cdot n\text{H}_2\text{O}$ and LiBr in ethanol with CO gave a green solution, and addition of amines to this gave the corresponding bromine complexes $\text{Ru}(\text{CO})_2\text{Br}_2\text{L}_2$,

L = C₆H₅NH₂, C₆H₅CH₂NH₂ and L₂ = o-phen. Refluxing the red or green solutions with anhydrous SnCl₂ or SnBr₂ respectively, and subsequent addition of pyridine gave [Ru(py)₂(CO)₂(SnX₃)₂] X = Cl, Br. Addition of o-amino-thiophenol,

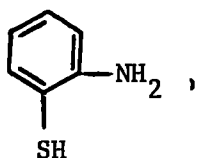

in ethanol to the red solution gave [Ru(CO)₂(C₆H₄(S)NH₂)₂]

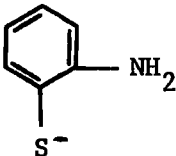
in which the ligand, , is acting as a uninegative bidentate

ion.²⁰⁴ Although the action of pyridine in ethanol on a freshly-prepared red solution gives cis[-Ru(CO)₂Cl₂(py)₂], if the red solution is allowed to "age" for 24 hrs. before the addition of pyridine, a complex [pyH][RuCl₄(CO)py] can be isolated. No evidence for the formation of [RuCl₂(CO)py₃] in the former reaction was found, but norbornadiene or cyclo-octa-1,5-diene with the red solution gave complexes of empirical formula [RuCl₂(CO)(diene)]²⁰⁵ and treatment of these with pyridine gave [RuCl₂(CO)py₃]. 3-Methylpyridine with the freshly prepared red solution gave cis[-RuCl₂(CO)₂(CH₃-C₅H₄N)]₂ but quinoline gave trans[RuCl₂(CO)₂(quin)₂].²⁰⁵

The dicarbonyl dihalides of Ru^{II} can be readily prepared by refluxing RuCl₃ in formic acid in the presence of the appropriate hydrohalic acid.²⁰⁶ The Ru(CO)₂X₂ complexes react readily with ligands to give Ru(CO)₂X₂L₂ complexes, RuCl₂(CO)₂(p-CH₃C₆H₄NH₂)₂ having been characterised.²⁰⁶

In their investigation of the reactivity of $\text{Ru}_3(\text{CO})_{12}$ Chandlin and co-workers²⁰⁷ obtained an insoluble polymeric material from the action of moist NO on $\text{Ru}_3(\text{CO})_{12}$. On the basis of its i.r. spectrum, they formulated the complex as a nitrite, of empirical formula $[\text{Ru}(\text{CO})_2(\text{NO}_2)_2]_n$.²⁰⁷

5. Cobalt, Rhodium and Iridium

Strong bases cause ready disproportionation of cobalt carbonyls to give the tetracarbonyl cobaltate anion:⁴

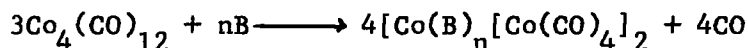
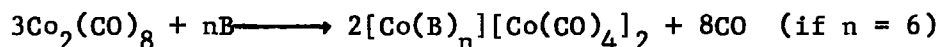

Reactions of the cobalt carbonyls with liquid ammonia have been studied at room temperature.²⁰⁸ With $\text{Co}_2(\text{CO})_8$, two reaction paths are followed, the first giving $[\text{Co}^{\text{+II}}(\text{NH}_3)_6][\text{Co}^{\text{-I}}(\text{CO})_4]_2 + \text{CO}$, and the second giving $\text{NH}_4[\text{Co}^{\text{-I}}(\text{CO})_4]$ and urea (by reaction of CO evolved with NH_3). $\text{Co}_4(\text{CO})_{12}$ reacts to give the same products, but only a very small amount of $\text{NH}_4[\text{Co}^{\text{-I}}(\text{CO})_4]$ and urea are produced, most of the $\text{Co}_4(\text{CO})_{12}$ reacting via the first pathway.²⁰⁸

$\text{Co}(\text{CO})_3(\text{NO})$, obtained from acidified mixtures of $\text{Co}(\text{CO})_4^-$ and NO_2^- , reacts with N-ligands with displacement of two CO groups.^{209,210} Thus pyridine gave $\text{Co}(\text{NO})(\text{CO})\text{py}_2$ in solution, which could not be isolated²⁰⁹, but o-phen and bipy gave the more stable derivatives $\text{Co}(\text{NO})(\text{CO})\text{o-phen}$ ^{209,210} and $\text{Co}(\text{NO})(\text{CO})\text{bipy}$.²⁰⁹ Reaction of $\text{Co}(\text{CO})_3\text{NO}$ with mixed phosphorus nitrogen

ligands (e.g. $\text{Et}_2\text{NC}_2\text{H}_4\text{P(Ph)C}_2\text{H}_4\text{NEt}_2$) gave only derivatives with phosphorus attached to the metal.²²¹ This is an example of a metal in a low oxidation state (a "soft" acid) preferring to co-ordinate to a "soft" base ($\cong\text{P}$) rather than a "hard" base ($\cong\text{N}$).²²¹

Using an indirect method in an attempt to synthesise cobalt carbonyl N-ligand compounds, Behrens and Aquila²¹² reacted $(\text{C}_6\text{H}_8)_2\text{Co}(\text{CO})_4$ ($\text{C}_6\text{H}_8 = \text{cyclohex-1,3-diene}$) with bipy, o-phen and tripy (2,2',2''-tripyridyl) in refluxing benzene, but obtained only the disproportionation products $[\text{Co}^{+\text{I}}\text{L}_3][\text{Co}^{-\text{I}}(\text{CO})_4]$. However, under the same conditions $(\text{nor-C}_7\text{H}_8)_2\text{Co}_2(\text{CO})_4$ ($\text{nor-C}_7\text{H}_8 = \text{norbornadiene}$) gave, with bipy, $\text{Co}_2(\text{CO})_4(\text{bipy})_2$ in 100% yield, and with o-phen, $\text{Co}_2(\text{CO})_4(\text{o-phen})_2$ and some $[\text{Co}(\text{o-phen})_3][\text{Co}(\text{CO})_4]$. With tripy, only the salt $[\text{Co}(\text{tripy})_2][\text{Co}(\text{CO})_4]$ could be obtained. From their i.r. spectra the complexes $\text{Co}_2(\text{CO})_4\text{L}_2$ were shown to have a cis-configuration, with bridging carbonyl groups,²¹² as shown in Fig.I.12

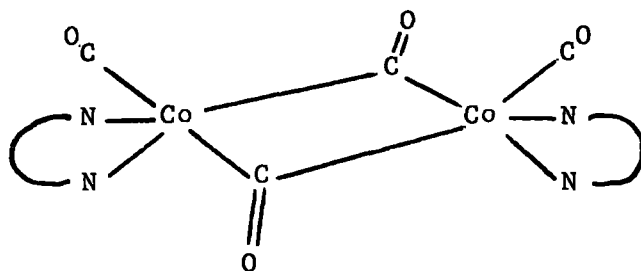

Fig.I.12.

A complex of empirical formula $(\pi\text{-C}_5\text{H}_5\text{Co})_2(\text{NBu}^t)_2\text{CO}$ was one of the products of the reaction between $\pi\text{-CpCo}(\text{CO})_2$ and N-t-butylsulphurimide, $(t\text{-C}_4\text{H}_9\text{N})_2\text{S}$.²¹³ Mass and i.r. spectral evidence suggests that the compound contains an alkylurea group, whose nitrogen atoms bridge the two cobalt atoms.²¹³ This structure, shown in Fig. I.13, has been confirmed by an X-ray diffraction study.²¹⁴

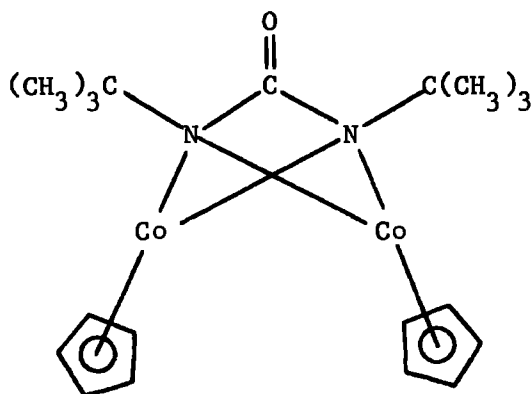

Fig. I.13.

This structure is similar to the structure of the iron compound, μ -diphenylureylene-bis(tricarbonyliron), Fig. I.11a.^{179,180}

There are comparatively few cobalt carbonyl derivatives containing a nitrogen atom attached to the metal. Direct reaction of bases with cobalt carbonyls causes disproportionation, and very few indirect synthetic methods have been attempted. As described earlier, though, $\text{Co}_2(\text{CO})_8$ is a catalyst in many organic reactions, including reactions of nitrogen compounds, and in the latter, the first step in the mechanism is thought to be co-ordination of the organic compound to the cobalt via the nitrogen lone pair.³⁶

There have been no reports of the direct reaction of N-bases with the rhodium and iridium carbonyls themselves, but, in contrast to cobalt, simple carbonyl halide derivatives of Rh and Ir are readily available and have proved useful in preparing compounds with nitrogen attached to the metal.²¹⁵⁻²²⁷

Reaction of $[\text{Rh}(\text{CO})_2\text{Cl}]_2$ with pyridine gave $\text{Rh}(\text{CO})_2\text{py}_2\text{Cl}$, which Hieber²¹⁵ suggested was dimeric, to account for its diamagnetism. Reaction with other ligands e.g. piperidine, o-phen and alkylamines gave indefinite products and Ph_3N did not react.²¹⁵ Wilkinson and Lawson²¹⁶ found that amines split the bridges in $[\text{Rh}(\text{CO})_2\text{Cl}]_2$ and $[\text{Rh}(\text{CO})_2\text{MeCO}_2]_2$ to give dichroic, mononuclear species which are decomposed by moisture to ill-defined straw-coloured solids. The complexes prepared were $\text{Rh}(\text{CO})_2\text{Cl}\cdot\text{L}$ where $\text{L} = \text{NH}_3, \text{NH}_2\text{OH}, \text{NH}_2\text{Me}, \text{NH}_2\text{Ph}, \text{NH}_2\text{C}_6\text{H}_4\text{-pMe}, \text{py}, (\alpha\text{-picoline}),$ and also $\text{Rh}(\text{CO})_2\text{py}\cdot\text{MeCO}_2, [\text{Rh}(\text{CO})_2\text{py}]_2\text{phthalate}$ and $[\text{Rh}(\text{CO})_2\text{Cl}]_2\text{bipy}$. In the last compound bipy is functioning as a bifunctional rather than a chelating ligand, but variation of the proportions of reactants gives some evidence for the formation of $\text{Rh}(\text{CO})\text{bipyCl}$ and $[\text{Rh}(\text{CO})_2\text{bipy}]\text{Cl}$. These authors²¹⁶ obtained Hieber's²¹⁵ compound $\text{Rh}(\text{CO})_2\text{py}_2\text{Cl}$ by dissolving $\text{Rh}(\text{CO})_2\text{Cl}\cdot\text{py}$ in pyridine, and present evidence supporting a 5-co-ordinate diamagnetic monomeric structure for the complex.²¹⁶ Aliphatic and aromatic nitriles react in a similar manner with $[\text{Rh}(\text{CO})_2\text{X}]_2$ ($\text{X} = \text{Cl}, \text{Br}$) to give $\text{Rh}(\text{CO})_2\text{XL}$, where $\text{L} = \text{PhCN}, \text{p-ClC}_6\text{H}_4\text{CN}, \text{o-, m- or p-MeC}_6\text{H}_4\text{CN}, \alpha\text{-C}_{10}\text{H}_7\text{CN}, \beta\text{-C}_{10}\text{H}_7\text{CN}, \text{PhCH}_2\text{CN}$ and $\text{p-ClC}_6\text{H}_4\text{CH}_2\text{CN}$.^{217,218} Two forms of the derivatives could be isolated, designated the α - and β -forms.²¹⁸ The α -form is more stable and is the simple square-planar complex; the β -form

probably involves some metal-metal interaction in the solid. Aliphatic nitrile compounds are much less stable than the aromatic ones and the CH_3CN and $\text{C}_2\text{H}_5\text{CN}$ derivatives could only be isolated at -78°C . Reaction of $\text{Rh}(\text{CO})_2\text{Cl}$ and $p\text{-NH}_2\text{-C}_6\text{H}_4\text{CN}$ gives a monomeric complex with only the amino-nitrogen co-ordinating to the metal.²¹⁸

Thiocyanate rhodium carbonyl complexes have been prepared e.g. $[\text{Rh}(\text{CO})_2\text{SCN}]_2$, from AgSCN and $[\text{Rh}(\text{CO})_2\text{Cl}]^{216}$, $[(n\text{-C}_4\text{H}_9)_4\text{N}][\text{Rh}(\text{CO})_2(\text{NCS})_2]$, and $\text{RhL}_2(\text{CO})\text{NCS}$ where L is a variety of phosphine, arsine, stibine and phosphite ligands.²¹⁹ The ionic compound was prepared by the action of excess $[(n\text{-C}_4\text{H}_9)_4\text{N}]\text{SCN}$ on $[\text{Rh}(\text{CO})_2\text{Cl}]_2$ and the other derivatives by the reaction of $\text{Rh}(\text{CO})\text{L}_2\text{Cl}$ and KSCN . All the complexes have metal-nitrogen bonding, as expected from π -bonding arguments discussed earlier, in the solid state and in solution. The arylarsine and triphenylphosphite derivatives show a remarkable tendency to form dinuclear, thiocyanate bridged complexes, the latter being isolated for $\text{L} = \text{triphenylphosphite}$:²¹⁹

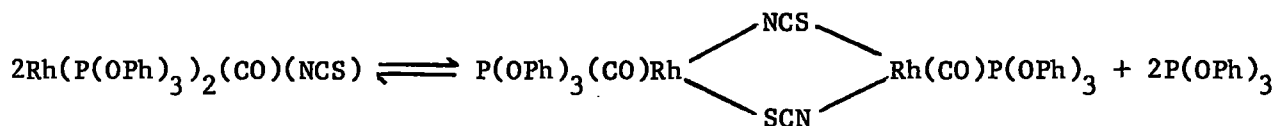

The iridium carbonyl halides also react readily with nitrogen donors to give simple derivatives. $[\text{Ir}(\text{CO})_3\text{Cl}]_n$, which is polymeric, reacts in refluxing benzene with $p\text{-CH}_3\text{C}_6\text{H}_4\text{NH}_2$ to give $\text{ClIr}(\text{CO})_2(\text{NH}_2\text{-C}_6\text{H}_4\text{p-Me})$ and treatment of this complex with py , $o\text{-phen}$ and bipy gives $\text{ClIr}(\text{CO})_2\text{py}$,

ClIr(CO)₂o-phen and [Ir(CO)₂Cl]₂bipy with a little Ir(CO)₂Clbipy.²²⁰ In ClIr(CO)₂o-phen, and the bipyridyl analogue, the metal is 5-co-ordinate. Angoletta²²¹ has also obtained the complexes Ir(CO)₂LX, where X = Cl, Br and L = (p-CH₃C₆H₄NH₂) and (CH₃)₂CHNH₂, by treatment of K₂[Ir₂(CO)₄Cl_{4.8}] or K₂[Ir₂(CO)₄Br₅] with the ligand. With K[Ir^{III}(CO)₄I₄] and p-CH₃C₆H₄NH₂, he obtained Ir(CO)₂(pCH₃C₆H₄NH₂)₂I₂, whereas bipy gave Ir(CO)(bipy)I₂, which was obtained as an isomeric mixture of, presumably, cis and trans modifications.²²² The reaction between K₂[Ir(CO)I₅] and ammonia, and primary amines in the cold, gives [Ir(CO)LI₄]⁻²²³ (L = NH₃, EtNH₂ and isopropylamine), when a 1:1 molar ratio of reactants is used. Excess amine gives Ir^{III}(CO)L₂I₃ in the cold, Ir^{II}(CO)L₃I₂ on warming.²²³

Some rhodium and iridium carbonyl derivatives of some Schiff bases of acetylacetone have been prepared.²²⁴ These are quite different from the Schiff base iron carbonyl complexes.¹⁸³ The complexes contain a chelating group which is the anion derived from the condensation product of a primary amine with acetylacetone. Thus the compounds of general formula [(CO)₂(amine)RhCl] and [(CO)₂(amine)IrCl] were prepared from [Rh(CO)₂Cl]₂ and from halogenocarbonyliridates, and then reacted with acetylacetone. In the case of iridium, the reactions were normally quite straightforward.

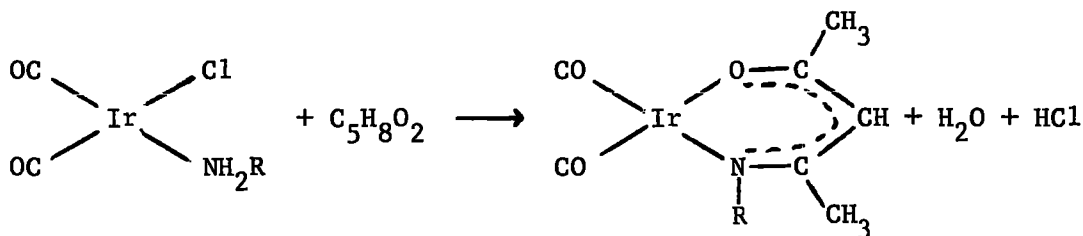

R = C₆H₅, p-CH₃C₆H₄, α-naphthyl, n-propylamine.

When R = isopropylamine, only the N-free dicarbonyl iridium(I) acetylacetonate was obtained. The reactions of $[\text{Rh}(\text{CO})_2(\text{amine})\text{Cl}]$ were much more complicated. For example $[(\text{CO})_2(\text{p-CH}_3\text{C}_6\text{H}_4\text{NH}_2)\text{RhCl}]$ reacted with acetylacetonate to give the N-containing chelate, but also some $[(\text{CO})_2\text{Rh}(\text{C}_5\text{H}_7\text{O}_2)]$ and some $[\text{p-CH}_3\text{C}_6\text{H}_4\text{NH}_3]^+[\text{cis}(\text{CO})_2\text{RhCl}_2]^-$. Several products were isolated when $[(\text{CO})_2\text{RhCl}]_2$ was treated with the Schiff base 2-p-tolylimino-penten-3-ol-4, $[(\text{CO})_2(\text{p-CH}_3\text{C}_6\text{H}_4\text{-NH}_2)\text{RhCl}]$ being one of the products. The complexes

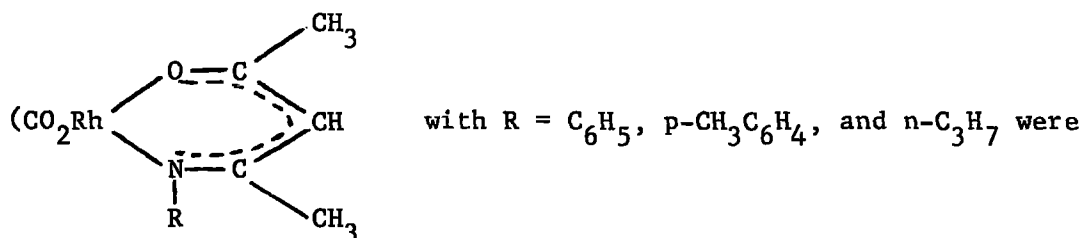

isolated as well as the amine complexes $\text{Rh}(\text{CO})_2(\text{L})\text{Cl}$, where L = $\text{C}_6\text{H}_5\text{NH}_2$, $\text{iso-C}_3\text{H}_7\text{NH}_2$, $2,6-(\text{CH}_3)_2\text{-C}_6\text{H}_3\text{NH}_2$, $\text{n-C}_3\text{H}_7\text{NH}_2$ and $\text{p-CH}_3\text{C}_6\text{H}_4\text{NH}_2$.²²⁴

Reaction of $[\text{Rh}(\text{CO})_2\text{Cl}]_2$ in benzene with assymetric chelating ligands having N and O atoms as donors, gave only non-chelated compounds with N atoms as donors.²²⁵ But if the reaction proceeds in the presence of BaCO_3 , in MeOH, chelated dicarbonyl derivatives are obtained:

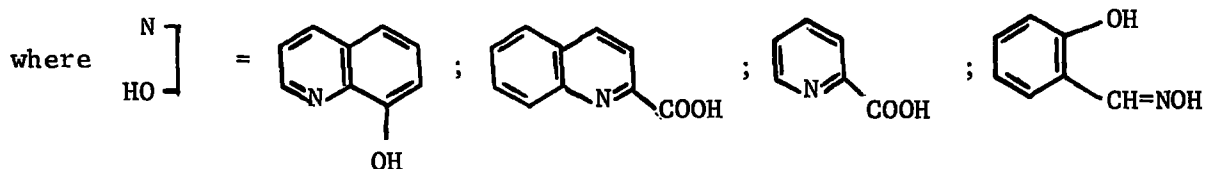
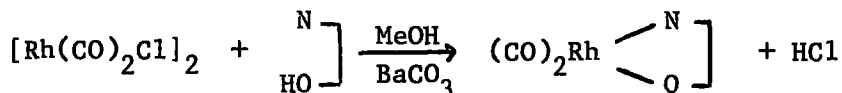

The analogous iridium derivatives, the 8-oxyquinolate, the quinaldinate and the α -pyridine-carboxylate complexes were obtained from

$\text{Ir}(\text{CO})_2(\text{p-CH}_3\text{C}_6\text{H}_4\text{NH}_2)\text{Cl}$, but the salicylaldoxinate was not prepared. The i.r. spectra of the complexes in the solid are much more complex than the solution spectra. Metal-metal interaction in the solid is suggested to account for this, and for the dark colours and dichroism of the compounds.²²⁵

Some iridium complexes, originally thought to be formates, have now been re-formulated as carbonyl derivatives²²⁶: $\text{IrCl}(\text{CO})\text{py}_2$, $[\text{IrCl}(\text{OAc})(\text{NH}_3)(\text{CO})_2]_2$ and $[\text{IrCl}(\text{OAc})(\text{CO})_2\text{py}]_2$. The first compound is prepared by the action of aqueous pyridine on $(\text{NH}_4)_2[\text{IrCl}_5(\text{CO})]$, while the last two result from the action of NH_3 and pyridine, respectively, on $[\text{IrCl}(\text{CO})_2(\text{OAc})]_2$.²²⁶ The reaction of $\text{IrI}_4(\text{CO})_2$ with a ligand, (e.g. 2,2'-bipyridyl) and methoxide ion gives complexes of the type $\text{IrI}_2(\text{OCOR})\text{L}_2(\text{CO})$. The crystal structure of the complex diiodocarbonylmethoxycarbonyl(2,2'-bipyridyl)iridium ($\text{L}_2 = \text{bipy}$, $\text{R} = \text{Me}$) has been determined and is shown in Fig.I.14.

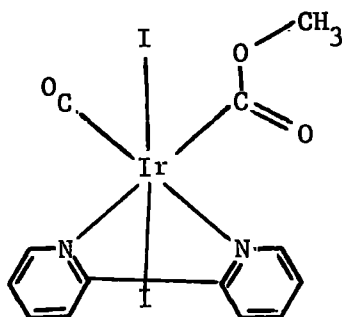
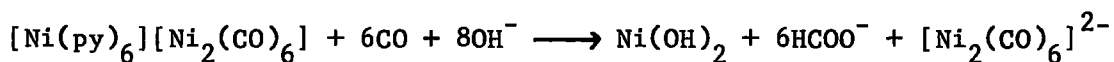

Fig.I.14.

6. Nickel, Palladium and Platinum

Bases co-ordinating through nitrogen atoms normally cause disproportionation of $\text{Ni}(\text{CO})_4$ to carbonyl-free cations and polynuclear carbonyl anions.⁴ In alkaline solution, $\text{Ni}(\text{CO})_4$ and pyridine give, initially $[\text{Ni}(\text{py})_6][\text{Ni}_2(\text{CO})_6]$ but further reaction occurs:



In acid solution, the $[\text{Ni}_4(\text{CO})_9\text{H}]^-$ anion forms. $\text{Ni}(\text{CO})_4$ with amines such as pyridine, morpholine and piperidine give $[\text{Ni}(\text{Base})_6][\text{Ni}_4(\text{CO})_9]$. Careful study of $\text{Ni}(\text{CO})_4$ /amine systems, where the amine is pyridine, α -picoline, morpholine and piperidine has shown that $\text{Ni}(\text{CO})_3\text{L}$ species exist in solution. On warming or pumping, $[\text{Ni}(\text{amine})_6][\text{Ni}_5(\text{CO})_9]$ forms, but the anion disproportionates to Ni and $[\text{Ni}_4(\text{CO})_9]^{2-}$.²²⁸ Addition of $[\text{Ni}(\text{o-phen})_3]^{2+}$, $[\text{Fe}(\text{o-phen})_3]^{2+}$ or o-phen to the $\text{Ni}(\text{CO})_4$ /py system gives $\text{Ni}(\text{CO})_2(\text{o-phen})^{228}$, which can also be prepared directly.²²⁹ $\text{Ni}(\text{CO})_4$ and bipyridyl also give $\text{Ni}(\text{CO})_2\text{bipy}$ as the primary product, which does not disproportionate, and may be isolated.²²⁹ Liquid ammonia and $\text{Ni}(\text{CO})_4$ give the intermediates $[\text{Ni}(\text{CO})_3\text{NH}_3]$ and $[\text{Ni}(\text{CO})_2(\text{NH}_3)_2]$, both of which disproportionate above -60°C .¹¹

Tetracarbonyl nickel reacts with dialkylcyanamides to give the complexes $[(\text{R}_2\text{N-CN})\text{Ni}(\text{CO})_2]$.²³⁰⁻²³² In a preliminary note on the complexes the metal ligand bonding was described as shown in Figure I.15 on the basis of i.r. spectroscopy.²³⁰ However a more detailed investigation²³¹ of several

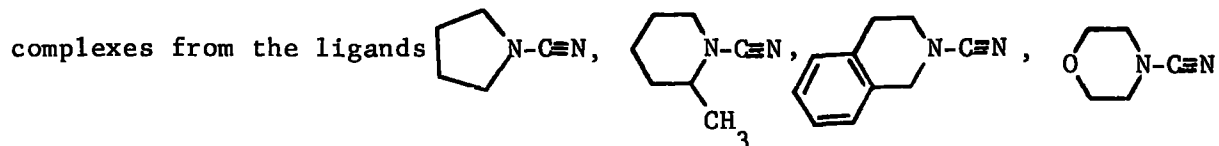

and -C≡N suggested that the -C≡N was in fact localised, and the structure was as shown in Fig.I.16.

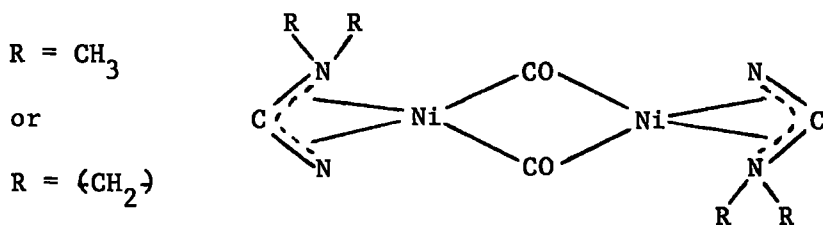

Fig.I.15.

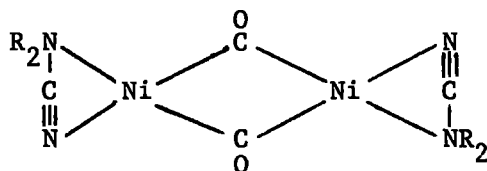

Fig.I.16.

This structure was based on i.r., n.m.r. and electronic spectral data, as well as molecular weight and dipole moment measurements.²³¹ A crystal structure determination of one of these complexes²³², carbonyl(piperidine-N-carbonitrile)nickel has shown that neither of the above descriptions is correct. The structure I.17 contains trimers of nickel atoms σ -bonded to CO and to a cyanonitrogen group. There are no $>N=C=NR_2$ groups as these would

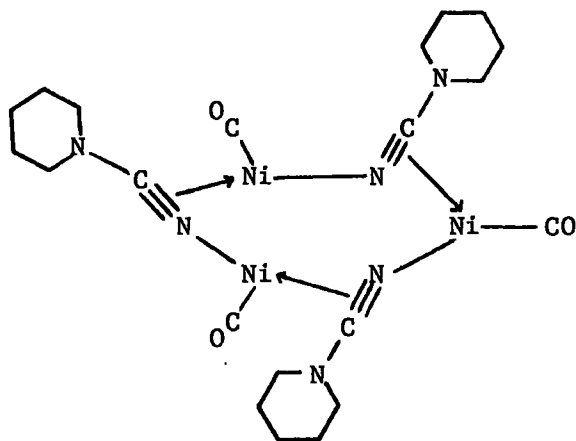

Fig. I.17.

be linear and perpendicular to the line Ni-Ni. The trimer is formed from the monomer by using the π -bonds of the cyano groups. The bond distances are in accord with $-\text{N}\equiv\text{C}-\text{NR}_2$ groups and the N and C atoms of the cyano-groups are equidistant from the π -bonded Ni. The N atom of the piperidine ring is not involved in bonding to Ni.²³²

The simple carbonyls, $\text{M}(\text{CO})_4$, of palladium and platinum are not known, but carbonyl halides and some base substituted compounds have been prepared.¹¹ An aqueous solution of PdCl_2 and an excess of o-phenanthroline react with air and CO to give a stable red complex, formulated as $[(\text{o-phen})\text{Pd}(\text{CO})_2\text{Pd}(\text{o-phen})].4\text{H}_2\text{O}$. The analogous bipyridyl derivative is unstable.²³³

Ammonia complexes e.g. $\text{Pt}(\text{CO})\text{Cl}_2 \cdot 2\text{NH}_3$ and $\text{Pt}(\text{CO})_2\text{Cl}_2 \cdot 2\text{NH}_3$ have been prepared by passing ammonia into CCl_4 solutions of $\text{Pt}(\text{CO})\text{Cl}_2$, $\text{Pt}(\text{CO})_2\text{Cl}_2$ or

$\text{Pt}_2(\text{CO})_3\text{Cl}_4$.²³⁴ Solutions of $[\text{PtCl}_4]^{2-}$ anions will react slowly with CO to give, probably, $[\text{Pt}(\text{CO})\text{Cl}_3]^-$, and addition of pyridine to the solution then gives $\text{trans-Pt}(\text{CO})\text{pyCl}_2$. The cis-ammonia derivative $[\text{PtNH}_3\text{Cl}(\text{CO})\text{Cl}]$ was prepared by the action of CO on a solution of $\text{NH}_4[\text{Pt}(\text{NH}_3)\text{Cl}_3]$.²³⁴

Several bases react with $[\text{Pt}(\text{CO})\text{X}_2]_2$ or $[\text{Pt}(\text{CO})\text{X}_3]^-$ to give the complexes $\text{trans-Pt}(\text{CO})\text{LX}_2$, where L = p-toluidine^{235,236}, aniline²³⁶, m-nitroaniline²³⁶, ammonia^{234,236} and pyridine^{234,236}, and X = Cl, Br, I. These derivatives are unstable with respect to excess of the ligand, CO being evolved with formation of $[\text{Pt}(\text{CO})\text{L}_2\text{X}]^+\text{X}^-$ (when L = NH_3) and $[\text{PtL}_2\text{X}_2]$ (when L = NH_3 , py).²³⁶ Bidentate ligands e.g. bipy^{235,236}, and o-phen²³⁶ give $[\text{Pt}(\text{CO})(\text{L-L})\text{X}]^+[\text{Pt}(\text{CO})\text{X}_3]^-$ and $[\text{Pt}(\text{CO})(\text{L-L})\text{X}]^+\text{X}^-$.

An indirect synthetic method²³⁷ involving the displacement of a π -bonded olefine from a Pt complex by CO, has enabled a large number of $(\text{CO})\text{PtCl}_2\text{L}$ complexes to be prepared:

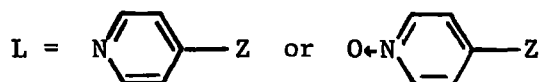
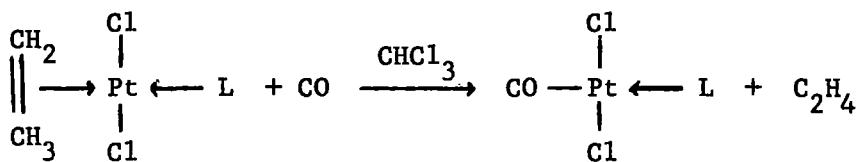

A study of the i.r. and n.m.r. spectra of the complexes with a variety of substituents in the pyridine ring (e.g. Z = CH_3 , OCH_3 , NO_2 , COCH_3 , CO_2CH_3 ,

CH_2OH , CN , C_6H_5) has indicated little $d\pi\text{-}p\pi^*$ interaction between CO and Pt in these complexes.²³⁷

CHAPTER TWO

Azomethine Derivatives of Transition Metals

A. Introduction

In this Chapter, studies of azomethine groups in transition metal systems will be described. Noncarbonyl cobalt(II) and nickel(II) systems were studied initially, and the work was then extended to cobalt carbonyl compounds.

Imino-compounds were chosen as ligands since, in principle, they can bond in a variety of ways to a transition metal. The simplest type of derivative would contain the neutral ligand $R_2C=NH$ σ -bonded to the metal via the nitrogen lone pair, but since the nitrogen is part of an unsaturated system, π -bonding via back-donation of electrons from filled metal d-orbitals into π -antibonding orbitals of the $>C=N-$ bond is possible. As an anionic ligand, the imino-group would formally be a 1- or 3-electron donor, but stabilisation through π -backbonding is still possible; the ligand could also bridge two metal atoms. A third bonding possibility would be lateral coordination of the $C=N-$ group to form a π -complex analogous to olefine complexes. The C-N stretching frequencies and, where appropriate, the carbonyl stretching frequencies, were expected to be sensitive to the mode of attachment of the ketimine group to the metal and it was hoped to study the bonding by infrared spectroscopy.

For a neutral ligand, the most likely geometrical arrangement of the relevant atoms is shown in Fig.II.1, together with π^* -orbitals involved in back-donation. The trigonal nitrogen atom is sp^2 hybridised, involving the p_x and p_y atomic orbitals (relative to the axes shown), while the p_z orbitals

on nitrogen and carbon overlap to form the π -bonding and -antibonding orbitals. The d_{xz} orbital on the metal would be of correct symmetry to overlap with the π^* orbitals.

If the imino-group is anionic, then several bonding modes are possible. Firstly, in one extreme the nitrogen lone pair could occupy the $sp^2_{x,y}$ orbital shown bonding the hydrogen in Fig.II.1. According to Ebsworth²³⁸, the lone pair in an sp -hybrid orbital may contribute significantly to $L \rightarrow M$ π -bonding, as he has calculated overlap integrals and on the basis of his results has agreed that substantial ($sp \rightarrow d$) π -bonding from a nitrogen lone pair to empty silicon d -orbitals is possible, in a non-linear system. If this were the case, then the ligand could be regarded as contributing more than one electron to the L - M bonding. Overlap of filled metal d -orbitals with the π^* orbitals of the ligand described above, is also possible.

The second extreme for the anionic ligand, a linear M - N - C skeleton is illustrated in Fig.II.2. This arrangement maximises the possibility of overlap between ligand π^* -orbitals and metal d -orbitals, and overlap of the nitrogen lone pair, in a pure p_y orbital, with suitable metal d -orbitals can also occur.

Of relevance here is the bonding of an imino group to the main group element, silicon. The u.v. spectra of iminosilanes have been interpreted to show that (a) the C - N - Si skeleton is bent and (b) that there is very little multiple bond character in the Si - N link.²³⁹ If these results can be applied to transition metals, where the d -orbitals are at least partially

The σ -bond skeleton and π -orbitals involved in metal-imine bonding

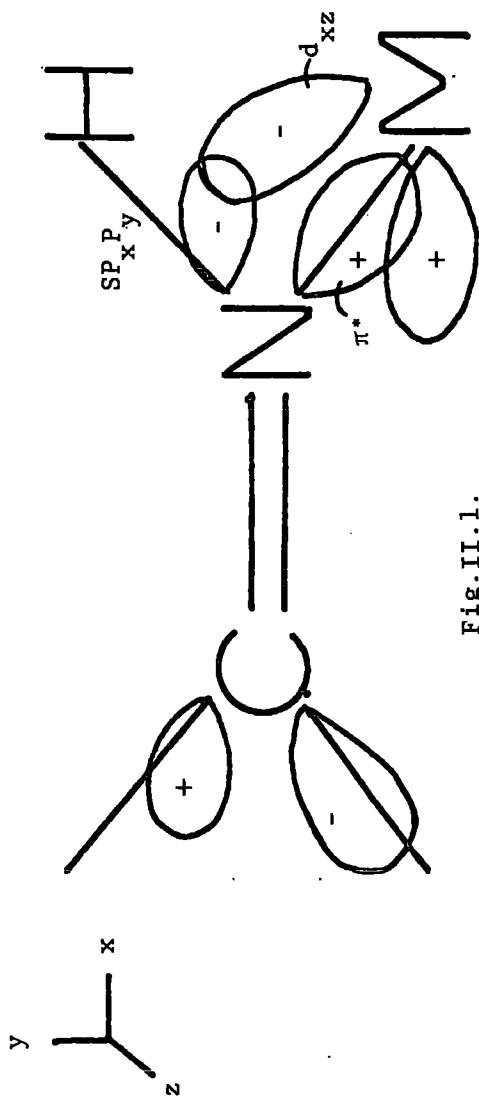

Fig. II.1.

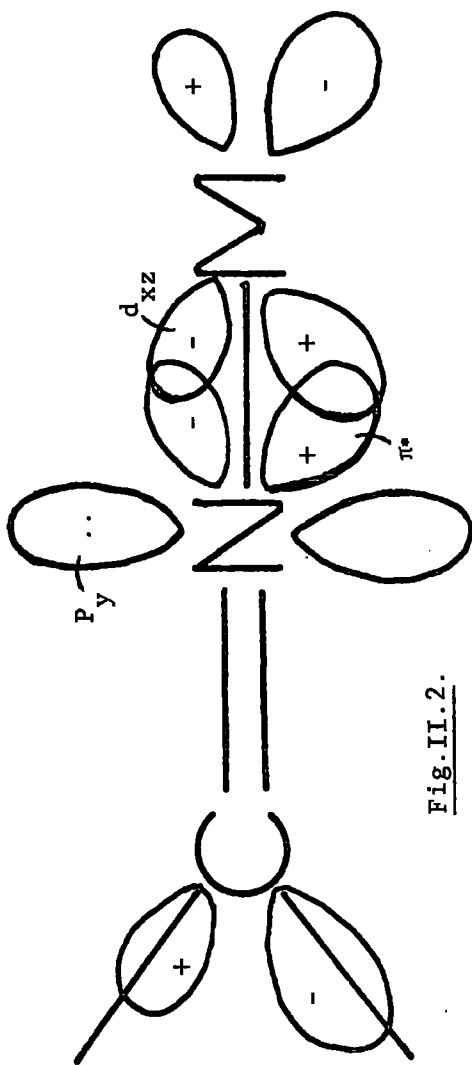

Fig. II.2.

1. Overlap of Md_{xz} with π^* (C-N) for trigonal nitrogen
2. Overlap of Md_{xz} with π^* (C-N) for linear nitrogen

filled, they would imply an angular arrangement based on sp^{1-2} hybridisation at the nitrogen atom, and that the lone pair could be available for donation to a second metal atom. In a ligand bridged dinuclear complex, overlap of d-orbitals on both metal atoms with the (C=N) π^* orbitals could occur, resulting in a weakening of the C=N bond. This should be reflected in a shift in the C=N vibrational frequency to a lower value than that found in a mononuclear derivative, and lower than in the free ligand.

If a comparison can be made between neutral imino-transition metal derivatives, and complexes of other ligands containing nitrogen in an unsaturated system (e.g. pyridine and bipyridyl derivatives), the amount of $d\pi-\pi^*$ interaction in the imino derivatives will probably be small. Studies of e.g. pyridine metal carbonyl complexes have suggested that this interaction is sometimes non-existent, and in other cases occurs only to a small extent.¹⁹ (p.9). Of the complexes containing anionic ligands discussed in Chapter I, the iron compound $[(\text{CH}_3\text{C}_6\text{H}_4\text{C}=\text{N})\text{Fe}(\text{CO})_3]_2$ ¹⁸⁵, I.11f.(p.60) is of particular relevance here. Its structure is consistent with sp^2 hybridised nitrogen and the short Fe-N bond distance (average $1.94 \overset{\circ}{\text{A}}$), shorter than in any other reported iron carbonyl nitrogen complex, implies some double bond character in the Fe-N bond of the type implied in the above description. Unfortunately, the C-N stretching frequency was not reported, so further discussion of the bonding from this point of view is not possible. However, the existence and structure of this complex support some of the ideas on π -bonding presented above. The complex $[(\text{Ph}_2\text{C}=\text{N}-\text{N})_2(\text{Fe}(\text{CO})_3)_3]$, I.11c.¹⁸²

is also noteworthy, as it contains two triply-bridging nitrogen atoms, and shows (together with other examples) that nitrogen is capable of coordination to polynuclear metal systems in ways at least as varied as carbon.

Arylketimines were used as starting materials as they are stable to re-arrangement, have been studied quite extensively and can be readily prepared. Alkylketimines would have provided more structural data from n.m.r. studies, but they could not be successfully synthesised in these laboratories.²⁴⁰ The preparation of alkylketimines has been reported by the addition of Grignards²⁴¹ or alkylaluminium²⁴² compounds to the corresponding nitriles and subsequent hydrolysis of the product. The difficulty in their synthesis is probably due to the hydrogen in the α -position in the ketimine, which enters into enamine tautomerism²⁴³, as has been observed for imino-silanes²³⁹; i.e.

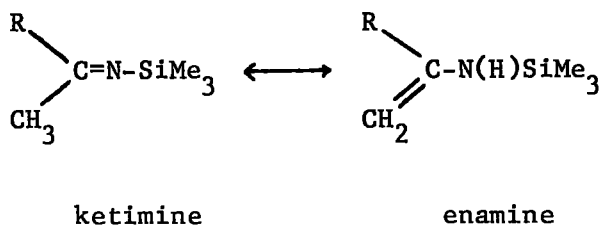

This labile hydrogen is acidic, and liberation of alkane from Grignards or alkylaluminium compounds has been observed²⁴⁴, and this factor is probably responsible for the difficulty in obtaining alkylketimines. Arylketimines are readily prepared from benzonitrile, by the Grignard route.²⁴⁰

Metathetical reactions using $\text{Ph}_2\text{C=NLi}$ and $\text{Ph}_2\text{C=NSiMe}_3$ with a metal halide complex have been studied in attempts to introduce ketimino groups into metal systems. In addition, homolytic cleavage of the N-N single bond in $\text{Ph}_2\text{C=N-N=CPh}_2$ by thermal or photochemical initiation in the presence of dicobalt octacarbonyl, was attempted.

B. Noncarbonyl cobalt complexes and ketimines

1. Experimental

(a) $2\text{Ph}_2\text{C=NLi} + \text{anhydrous CoCl}_2$

A solution of diphenylketiminolithium (15.2 mmoles) in ether (40 ml.) was prepared as follows. A solution of diphenylketimine (2.75 g., 2.60 ml.) in ether in one arm of a double Schlenk tube, was frozen to -196°C and an equimolar quantity of n-butyl lithium in hexane was added by syringe. (Methyl lithium in ether may also be used²⁴⁵, but is less readily available). The red mixture was allowed to warm up to room temperature and stirred for 1 hr. to ensure complete reaction. Anhydrous cobalt chloride (1.0 g., 7.6 mmoles) was slurried with ether (25 ml.) and added by syringe to the blood-red ketiminolithium solution. An immediate darkening in colour through brown to black was observed. After overnight stirring the solvent was removed under vacuum, leaving a grey-black gum. Although the gum was slightly miscible with petroleum ether (80-100^o) and more so with toluene, efforts to obtain a solid resulted only in a black tar.

Addition of triphenylphosphine to a toluene solution of the gum still resulted in isolation of a black tar, which turned greeny-yellow on exposure

to air. When the reaction was repeated by adding a THF solution of CoCl_2 to the $\text{Ph}_2\text{C=NLi}$ solution cooled to -196°C , and allowing the mixture to warm up slowly, the black colour developed well below room temperature, but again no product could be isolated.

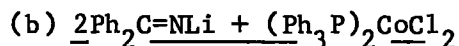

A solution of diphenylketimino lithium (4 mmoles) in ether (20 ml.) was prepared as above. Bis(triphenylphosphine)cobalt dichloride (1.4 g., 2.1 mmoles) was dissolved in THF to give a deep blue solution which was cooled to -196°C . The $\text{Ph}_2\text{C=NLi}$ solution was added by syringe, and the mixture allowed to warm to room temperature, when a blue solution and much blue precipitate were observed. After stirring for 30 min. at room temperature, the solvent was removed under vacuum, leaving a mixture of blue and white solids. Washing with petroleum ether (4 x 10 ml.) and evaporation of the washings gave white crystals of triphenylphosphine, which were identified by the melting point (77°C , lit. 80°C) and by comparison of the infrared spectrum with that of an authentic sample.

The blue solid remaining was recrystallised by continuous liquid extraction with hot benzene. After cooling to room temperature, the crystals were washed with petroleum ether and pumped dry. The compound was characterised as bis(diphenylketimine)cobalt dichloride, $(\text{Ph}_2\text{C=NH})_2\text{CoCl}_2$. M.Pt. $238-242^\circ\text{C}$. Yield, 0.72 g. (72%). Found: C, 63.4; H, 4.3; N, 5.6; Cl, 14.4%. $\text{CoC}_{26}\text{H}_{22}\text{N}_2\text{Cl}_2$ requires C, 63.4; H, 4.5; N, 5.7; Cl, 14.4%. The infrared

spectrum showed that hydrogen has become attached to the nitrogen, and confirmed the absence of triphenylphosphine.

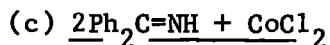

Anhydrous cobalt chloride (1.6 g., 12 mmoles) and diphenylketimine (5 ml., 25 mmoles) were reacted together by continuous liquid extraction of cobalt chloride into a THF solution of the ketimine. The initially pale yellow solution slowly became blue, and after overnight extraction, much blue solid had precipitated. After cooling to room temperature, the blue solid was isolated by filtration and recrystallised from benzene by continuous liquid extraction, washed with pentane and pumped dry. The complex, bis(diphenylketimine)cobalt dichloride was identical to the sample prepared in (b). M.Pt. 237-241°C. Found: C, 63.6; H, 4.5; N, 5.7; Cl, 15.0%. $\text{CoC}_{26}\text{H}_{22}\text{N}_2\text{Cl}_2$ requires C, 63.4; H, 4.5; N, 5.7; Cl, 14.4%.



Bis(triphenylphosphine)cobalt dichloride (1.3 g., 2 mmoles) was dissolved in THF (45 ml.) and a solution of N-(trimethylsilyl)diphenylketimine (0.95 ml., 4 mmoles) in THF (5 ml.) was added. No change was observed, and after overnight stirring, the solvent was removed under vacuum, leaving a blue solid. This compound was appreciably soluble in petroleum ether (80-100°C) and pentane, and was extracted with hot toluene (50 ml., oil bath 90-100°C). On cooling the filtered solution in an ice bath, a solid (I) precipitated which was collected by filtration, washed with pentane

and pumped dry. M.Pt. $182-4^{\circ}\text{C}$. Found: C, 64.8; 65.4; 65.5%.
H, 3.6; 3.8; 5.1%.

$(\text{Ph}_2\text{C}=\text{NH})(\text{Ph}_3\text{P})\text{CoCl}_2$ requires C, 64.6; H, 4.5. The infrared spectrum showed bands due to both triphenylphosphine and diphenylketimine, and I is formulated as $(\text{Ph}_3\text{P})(\text{Ph}_2\text{C}=\text{NH})\text{CoCl}_2$. Further comment is deferred until the next section.

The blue toluene mother liquor remaining after separation of I, after standing at room temperature for 2 days, deposited blue crystals, leaving an almost colourless solution. On washing these crystals with pentane, the washings remained colourless, and attempts to redissolve the crystals in toluene (at $90-100^{\circ}$ oil bath temperature, for 24 hrs.) were unsuccessful. The crystals (II) were isolated, washed with petroleum ether ($80-100^{\circ}$) and pumped dry. M.Pt. 228°C . The infrared spectrum of II differed from that of I, $(\text{Ph}_3\text{P})(\text{Ph}_2\text{C}=\text{NH})\text{CoCl}_2$, and showed that loss of triphenylphosphine had occurred. This complex is also described in section 2.



The reaction was repeated as above, and after filtration of the THF solution and evaporation to small bulk, cooling to -78°C caused crystallisation of a blue solid. This was washed rapidly with pentane and pumped dry. This compound was identical to I above, and was identified as $(\text{Ph}_3\text{P})(\text{Ph}_2\text{C}=\text{NH})\text{CoCl}_2$. M.Pt. $197-199^{\circ}\text{C}$. Found: C, 64.8; H, 4.7; N, 2.5; Cl, 12.5%. $\text{CoC}_3\text{H}_{22}\text{NPCl}_2$ requires C, 64.6; H, 4.5; N, 2.4; Cl, 12.4%. The infrared spectrum confirmed the presence of co-ordinated triphenylphosphine and diphenylketimine, and also hydrogen on the nitrogen.

Prolonged standing at room temperature of the THF mother liquor caused deposition of blue crystals, which were isolated, washed with pentane and pumped dry. The infrared spectrum of these crystals was identical to that of II and showed loss of PPh_3 had occurred. This complex is tentatively formulated as $[(\text{Ph}_2\text{C}=\text{NH})\text{CoCl}_2]_2$. M.Pt. 212°C . Found: C, 55.3; H, 3.4; Cl, 25.8%
C, 53.3; H, 4.5; Cl, 21.9%.

$\text{Co}_2\text{C}_{26}\text{H}_{22}\text{N}_2\text{Cl}_4$ requires C, 50.2; H, 3.5; Cl, 22.8%.

Evaporation of the almost colourless THF mother liquor gave a grey, gummy solid, whose infrared spectrum indicated the presence of PPh_3 and probably $\text{Ph}_2\text{C}=\text{N}-\text{SiMe}_3$.

Loss of triphenylphosphine from I, $(\text{Ph}_3\text{P})(\text{Ph}_2\text{C}=\text{NH})\text{CoCl}_2$, was achieved by heating a little of I in toluene for 3 days, at $90-100^\circ\text{C}$ (oil bath temperature). The blue crystals which separated out had an infrared spectrum identical to that of II. Evaporation of the almost colourless toluene solution gave a gummy white solid whose infrared spectrum indicated the presence of PPh_3 and probably benzophenone.

Attempted sublimation of $(\text{Ph}_3\text{P})(\text{Ph}_2\text{C}=\text{NH})\text{CoCl}_2$ at 70°C over 2 weeks, produced a small amount of white solid, which consisted of PPh_3 and probably benzophenone, as determined by infrared. The blue residue was extracted with toluene until the washings were colourless. $(\text{Ph}_3\text{P})(\text{Ph}_2\text{C}=\text{NH})\text{CoCl}_2$ was recovered from the toluene extracts. The small amount of toluene insoluble material remaining had an infrared spectrum similar to that of II. However, this compound, III, did not melt below 360°C , although the colour paled to grey during heating. Found: C, 27.5; H, 2.56; Cl, 19.6%.

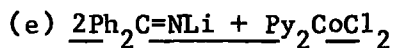

A solution of diphenylketiminolithium (10 mmoles) in ether (50 ml.) was prepared as described in (a). Bis(pyridine)cobalt dichloride (1.4 g., 5 mmoles) was dissolved in THF (100 ml.) and the solution cooled to -198°C . After addition of the $\text{Ph}_2\text{C=NLi}$ solution, the temperature of the mixture was allowed to rise. A black colour developed while the temperature was still below room temperature. Removal of volatiles under vacuum gave a black tar which was miscible with ether and toluene, but attempts to isolate a solid from these solutions were unsuccessful.

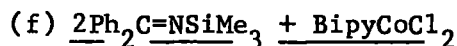

(i) 2,2'-Bipyridylcobalt dichloride (0.43 g., 1.5 mmoles) was placed in one arm of a double Schlenk tube, nitrobenzene (100 ml.) was added and the suspension heated overnight at 100°C (oil bath temperature). Some of the complex dissolved to give a green solution. N(trimethylsilyl)diphenylketimine (3 mmoles) was diluted with nitrobenzene (10 ml.) and added to the hot suspension. No reaction occurred over 3 days at this temperature.

(ii) 2,2'-Bipyridylcobalt dichloride (0.86 g., 3 mmoles) was placed in a flask and N(trimethylsilyl)diphenylketimine (1.5 ml., 6 mmoles) was added. The solid dissolved to some extent, giving a blue-green solution. After stirring overnight, at room temperature, then heating at $80-90^\circ\text{C}$ for several days, no change was observed and no new species could be detected.

(iii) 2,2'-Bipyridylcobalt dichloride (1.7 g., 6 mmoles) and

N(trimethylsilyl)diphenylketimine (3 ml., 12 mmoles) were placed in a thick walled glass tube, which was then evacuated and sealed. The tube was heated, with the temperature being raised in steps. No change was observed until the temperature had reached 276°C, when a darkening in colour was noticed. (BipyCoCl₂ decomposes at 268°C, under nitrogen)²⁴⁶ The tube was cooled to room temperature and extracted with pentane. The black residue was shown to contain bipyCoCl₂ (by infrared spectroscopy). Removal of solvent from the pentane extracts gave a dark red oil, which was distilled at 80-110°C, 0.01 mm/Hg to yield 2 ml. of a yellow viscous liquid. This was shown to be slightly impure Ph₂C=NSiMe₃, by infrared spectroscopy. A small amount of black solid remained after distillation of the oil. Since ~65% of Ph₂C=NSiMe₃ was recovered, it was concluded that no reaction had occurred apart from some decomposition.

2. Results and Discussion

Reaction of (Ph₃P)₂CoCl₂ with Ph₂C=NLi and Ph₂C=N-SiMe₃ gave the bright blue crystalline complexes (Ph₂C=NH)₂CoCl₂ and (Ph₃P)(Ph₂C=NH)CoCl₂, respectively, which were identified by elemental analyses and infrared spectroscopy. (Ph₂C=NH)₂CoCl₂ was also prepared directly from anhydrous CoCl₂ and Ph₂C=NH, but reaction of Ph₂C=NLi with anhydrous CoCl₂ gave a black tar from which no solid could be isolated, even after the addition of triphenylphosphine. The colours of the complexes (Ph₂C=NH)₂CoCl₂ and (Ph₃P)(Ph₂C=NH)₂CoCl₂ are characteristic of tetrahedral Co^{II} complexes, and the tetrahedral structure of (Ph₂C=NH)₂CoCl₂ is confirmed by its diffuse

reflectance spectrum, recorded in the range $25,000\text{ cm}^{-1}$ to $10,000\text{ cm}^{-1}$ ($400\text{ m}\mu$ to $1,000\text{ m}\mu$), which shows a broad intense band at $16,000\text{ cm}^{-1}$ with two shoulders at $16,560\text{ cm}^{-1}$ and $17,090\text{ cm}^{-1}$. Tetrahedral cobalt(II) halide complexes of 2-chloropyridine and 2-bromopyridine have similar spectra with the intense band near $16,000\text{ cm}^{-1}$.²⁴⁷

On prolonged standing in toluene or THF solution, or on heating in toluene, $(\text{Ph}_3\text{P})(\text{Ph}_2\text{C}=\text{NH})\text{CoCl}_2$ loses PPh_3 and blue crystals of a complex, (II), are deposited. PPh_3 , contaminated with benzophenone, was recovered from the THF mother liquor and identified by infrared spectroscopy. The infrared spectrum of II shows the absence of PPh_3 in the complex, and contains bands due to co-ordinated $\text{Ph}_2\text{C}=\text{NH}$. The positions of these bands are very similar to those in the spectrum of the complex $(\text{Ph}_2\text{C}=\text{NH})(\text{PPh}_3)\text{CoCl}_2$. The bright blue colour of II is characteristic of tetrahedral cobalt(II) complexes, and it seems likely that loss of PPh_3 from $(\text{Ph}_2\text{C}=\text{NH})(\text{PPh}_3)\text{CoCl}_2$ has caused dimerisation and the data on complex II is consistent with the formulation $[(\text{Ph}_2\text{C}=\text{NH})\text{CoCl}_2]_2$. The infrared spectra, particularly the presence of $\nu\text{N-H}$ indicate that the environment of the co-ordinated diphenylketimine is little changed upon dimerisation, and so II probably contains chlorine bridges. The analytical data obtained on II supports the formulation, although it suggests that the sample isolated was slightly contaminated, probably with $(\text{Ph}_3\text{P})(\text{Ph}_2\text{C}=\text{NH})\text{CoCl}_2$.

After heating $(\text{Ph}_3\text{P})(\text{Ph}_2\text{C}=\text{NH})\text{CoCl}_2$ in the solid state for several days, most of the complex was recovered, but a little blue, insoluble solid, III,

remained. The infrared spectrum of III was very similar to that of II, and showed that complete loss of PPh_3 had again occurred, but that co-ordinated diphenylketimine was still present. The blue colour of III is again characteristic of tetrahedral cobalt(II) complexes. However, complex III was shown to be different from II; its carbon content was considerably lower and it did not melt below 360°C (m.pt. II, 212°C). Complex III is tentatively formulated as a polymeric compound formed from $(\text{Ph}_3\text{P})(\text{Ph}_2\text{C}=\text{NH})\text{CoCl}_2$ by loss of PPh_3 and possibly some $\text{Ph}_2\text{C}=\text{NH}$. Polymeric structures with chlorine bridges are known for other cobalt chloride complexes, for example anhydrous CoCl_2 ²⁴⁸ and the violet form of Py_2CoCl_2 , in which the cobalt is in an octahedral environment.²⁴⁹ (Py_2CoCl_2 also exists in a less stable blue monomeric, tetrahedral form which converts to the violet form on standing).²⁴⁹

Reaction of $(\text{py})_2\text{CoCl}_2$ with $\text{Ph}_2\text{C}=\text{NLi}$ at room temperature gave a black tar; the smell of free pyridine was detected during the reaction, although solid $(\text{py})_2\text{CoCl}_2$ does not begin to lose pyridine until 102°C .²⁴⁶ The black tar produced resembled that obtained in the reaction of $\text{Ph}_2\text{C}=\text{NLi}$ with CoCl_2 , and again no solid could be isolated. Using $(\text{bipy})\text{CoCl}_2$ and $\text{Ph}_2\text{C}=\text{NLi}$, no reaction could be detected below 276°C , when decomposition occurred; $(\text{Bipy})\text{CoCl}_2$ begins to decompose at 268°C , under nitrogen.²⁴⁶

The absorptions in the infrared spectra of $(\text{Ph}_2\text{C}=\text{NH})_2\text{CoCl}_2$ and $(\text{Ph}_3\text{P})(\text{Ph}_2\text{C}=\text{NH})\text{CoCl}_2$ are listed in Table II.1, which also includes the spectra of $(\text{Ph}_3\text{P})_2\text{CoCl}_2$ and $\text{Ph}_2\text{C}=\text{NH}$ for comparison. The spectra of the two polymeric compounds derived from $(\text{Ph}_3\text{P})(\text{Ph}_2\text{C}=\text{NH})\text{CoCl}_2$ were identical to that of

Table II.1.

Infrared Spectra of tetrahedral Co^{II} complexes (Nujol mull) and of $\text{Ph}_2\text{C}=\text{NH}$ (liquid smear)

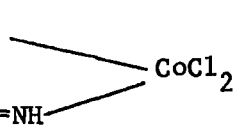
Ph_3P  CoCl_2 $\text{Ph}_2\text{C}=\text{NH}$	$(\text{Ph}_2\text{C}=\text{NH})_2\text{CoCl}_2$	$\text{Ph}_2\text{C}=\text{NH}$	$(\text{Ph}_3\text{P})_2\text{CoCl}_2$
cm^{-1}	cm^{-1}	cm^{-1}	cm^{-1}
3279(vw)	3279(w)	3257(w)	
1600(s)	1597(s)	1603(m)	
1567(s)	1567(s)	1572(m)	
1479(sh)			
1451(sh)	1451(sh)	1449(m)	
1437(s)			1435(s)
1393(sh)	1395(sh)	1364(s)	
1238(m)	1236(ms)		
1186(w)		1196(ms)	1181(w)
1161(w)	1163(w)	1179(sh)	1156(w)
1126(vw)		1149(w)	
1099(s)			1096(s)
1075(w)	1075(w)	1072(w)	1068(vw)
1029(m)	1030(w)	1029(w)	1026(w)
1000(m)	1000(w)	1000(vw)	997(w)
973(w)			
939(w)	939(m)	927(m)	
911(w)	910(m)		
868(s)	868(s)	891(s)	
	852(sh)		
791(s)	791(s)	787(s)	
763(s)	763(s)	761(s)	
745(vs)			746(vs)
740(sh)			740(sh)
		719(w)	
709 } s	708 } vs		709(ms)
704 } split	704 } split		
693(vs)	695(s)	696(vs)	692(vs)
643(s)	643(s)	623(s)	
617(w)	616(vw)		
521(vs)			520(vs)
499(vs)			497(vs)

$(\text{Ph}_2\text{C}=\text{NH})_2\text{CoCl}_2$. The $\nu\text{N-H}$ and $\nu\text{C}=\text{N}$ stretching frequencies of several diphenylketimine complexes of transition metals are shown in Table II.2, for comparison. It can readily be seen that there is no distinct trend in behaviour of either parameter. The shift to higher frequency of $\nu\text{N-H}$ in the cobalt complexes, in $(\text{Ph}_2\text{C}=\text{NH})_2\text{CuCl}_2$ and in the molybdenum carbonyl complex is also observed in diphenylketimine adducts of main group metals.²⁵³ In the manganese carbonyl halide derivatives, the shift to lower frequencies of $\nu\text{N-H}$ is consistent with electron withdrawal from nitrogen via the σ -bond, upon co-ordination. $\nu\text{C}=\text{N}$ seems to be little affected by co-ordination of the ligand, as has been observed for main group metal complexes.²⁵³

Attempts to obtain mass spectra of $(\text{Ph}_2\text{C}=\text{NH})_2\text{CoCl}_2$ and $(\text{Ph}_3\text{P})(\text{Ph}_2\text{C}=\text{NH})\text{CoCl}_2$, were unsuccessful. Direct insertion of the former compound, with the source at temperatures of 95°C , 160°C and 200°C gave spectra showing a parent peak at M/e 181 ($\text{Ph}_2\text{C}=\text{NH}^+$) and fragments due to breakdown of this ion. No cobalt-containing peaks could be detected. Similarly, the spectrum of $(\text{Ph}_3\text{P})(\text{Ph}_2\text{C}=\text{NH})\text{CoCl}_2$ obtained with a source temperature of 190°C showed only peaks characteristic of $[\text{Ph}_3\text{P}]^+$ and $[\text{Ph}_2\text{C}=\text{NH}]^+$.

The reluctance of diphenylketimine to complex with transition metals as an anionic ligand is somewhat surprising, since main group metal halides (aluminium²⁵⁴, beryllium²⁵⁴ and boron²⁵⁵) react readily with ketiminolithium at room temperature to eliminate LiX . Reaction of $\text{Ph}_2\text{C}=\text{NLi}$ with $\text{Mn}(\text{CO})_5\text{Cl}$ gave two complexes, one of which was formulated as $\text{Mn}(\text{CO})_n\text{N}=\text{CPh}_2$ ($n = 4$ or 5),

Table II.2.

$\nu_{\text{N-H}}$ and $\nu_{\text{C=N}}$ for some Transition Metal
Diphenylketimine Complexes

Complex	$\nu_{\text{N-H}}$ (cm^{-1})	$\nu_{\text{C=N}}$ (cm^{-1})
$\text{Ph}_2\text{C=NH}$	3257	1603
$(\text{Ph}_2\text{C=NH})_2\text{CoCl}_2$	3279	1597
$(\text{Ph}_2\text{C=NH})(\text{PPh}_3)\text{CoCl}_2$	3279	1600
$\text{CuCl}_2 \cdot (\text{Ph}_2\text{C=NH})_2^{250}$	3281	1607
$\text{CuCl}_2 \cdot \text{Ph}_2\text{C=NH}^{250}$	3200	1601
$\text{Mn}(\text{CO})_3(\text{Ph}_2\text{C=NH})_2\text{Cl}^{251}$	3215	1618, 1597
$\text{Mn}(\text{CO})_3(\text{Ph}_2\text{C=NH})_2\text{Br}^{251}$	3215	1616, 1597
$\text{Mo}(\text{CO})_3(\text{Ph}_2\text{C=NH})_3^{252}$	3279	1595

although $\text{Ph}_2\text{C}=\text{NSiMe}_3$ with $\text{Mn}(\text{CO})_5\text{Br}$ gave only $\text{Mn}(\text{CO})_3(\text{Ph}_2\text{C}=\text{NH})_2\text{Br}$.²⁵¹ The source of the hydrogen introduced into the ligand in the formation of ketimine-cobalt complexes from $\text{Ph}_2\text{C}=\text{NLi}$ and $\text{Ph}_2\text{C}=\text{NSiMe}_3$ is thought to be the solvent. The ketimine-copper complexes referred to in Table II.2 were prepared by direct reaction of $\text{Ph}_2\text{C}=\text{NH}$ with anhydrous CuCl_2 , $(\text{Ph}_2\text{C}=\text{NH})_2\text{CuCl}_2$ being the major product.²⁵⁰ The tetrahedral cobalt complexes $(\text{py})_2\text{CoCl}_2$ and $(\text{bipy})\text{CoCl}_2$ were prepared and reacted with $\text{Ph}_2\text{C}=\text{NLi}$ and $\text{Ph}_2\text{C}=\text{NSiMe}_3$ in the hope that the nitrogen ligands already present in the complex would encourage the formation of a ketimino derivative. Lack of reaction between bipyCoCl_2 and $\text{Ph}_2\text{C}=\text{NSiMe}_3$ indicates that even when displacement of the neutral ligand in the starting material by $\text{Ph}_2\text{C}=\text{NH}$ is made unfavourable by the presence of a strongly bonding chelating ligand, the alternative reaction i.e. elimination of Me_3SiCl still will not occur

Differences in behaviour between $\text{Ph}_2\text{C}=\text{NLi}$ and $\text{Ph}_2\text{C}=\text{NSiMe}_3$ have been observed with other metals. The $\text{Mn}(\text{CO})_5\text{X}$ system has been mentioned in the preceding paragraph.²⁵¹ In main group metal systems, $\text{Ph}_2\text{C}=\text{NLi}$ with aluminium and beryllium chlorides, displaces all the halogens²⁵⁴, whereas excess $\text{Ph}_2\text{C}=\text{NSiMe}_3$ will replace only one halogen in each metal halide.²⁵⁴ Nevertheless, it seems surprising that $\text{Ph}_2\text{C}=\text{NLi}$ readily replaces both triphenylphosphine groups in $(\text{Ph}_3\text{P})_2\text{CoCl}_2$ while gaining a proton, whereas $\text{Ph}_2\text{C}=\text{NSiMe}_3$ will replace only one PPh_3 group, although the resulting complex can slowly lose the remaining Ph_3P group and polymerise.

C. Non-carbonyl nickel systems

Although L_2COX_2 complexes usually exist in a tetrahedral configuration in the solid state, tetrahedral, square planar and octahedral configurations are known for the nickel complexes L_2NiX_2 .²⁵⁶ However, $(Ph_3P)_2NiCl_2$ has been shown to have a tetrahedral configuration²⁵⁷ and studies of the reactions of this complex with diphenylketimine and its trimethylsilyl derivative were undertaken. However, addition of THF to the very dark blue crystals of $(Ph_3P)_2NiCl_2$ gave a violet solution, but also a voluminous pale-yellow precipitate, and the investigation of this reaction will be described first.

1. $(Ph_3P)_2NiCl_2 + THF$

Bis(triphenylphosphine)nickel dichloride (4 g., 6 mmoles) was placed in a flask and THF (30 ml.) was added. The solvent immediately became darkly coloured, and rapid formation of a pale yellow precipitate was observed. After stirring for 30 min. the precipitate was allowed to settle. This occurred only very slowly, though, and so the suspension was refluxed overnight in an attempt to coagulate the precipitate. After cooling to room temperature, the blue-green mother liquor was removed by filtration, and the residue refluxed for several hours with more THF (10 ml.). This was repeated twice more, and the cream coloured residue finally washed with THF until the washings were no longer green, then pumped dry. The combined mother liquor and washings were pumped dry, and the green solid remaining was washed with pentane (4 x 10 ml.). On evaporation of the pentane washings,

triphenylphosphine (identified by infrared spectroscopy) was recovered (2 g., 62%). The green solid remaining after washing with pentane was shown by infrared spectroscopy to be unreacted $(\text{Ph}_3\text{P})_2\text{NiCl}_2$.

The cream powder is deliquescent and gradually turns green on standing in the air. Its infrared spectrum (Nujol mull) shows bands at 1350(sh), 1261(vw), 1176(w), 1055(sh), 1042(vs), 918(s,sh), 885(vs), 800(vw), 722(w), 680(w) cm^{-1} , which can be attributed to co-ordinated THF. (THF itself absorbs at 1370(vw), 1179(w), 1073(vs), 1033(sh), 912(s), 658(w,broad) cm^{-1}). Analytical data on the compound, is shown in Table II.3, together with theoretical values for $\text{NiCl}_2 \cdot 2\text{THF}$, $\text{NiCl}_2 \cdot \text{THF}$ and NiCl_2 .

Table II.3.

	%C	%H	%Cl	%Ni
Found	33.5	5.4	31.8, 29.4	23.4
$\text{NiCl}_2 \cdot 2\text{THF}$ requires	35.0	5.8	25.9	21.5
$\text{NiCl}_2 \cdot \text{THF}$ requires	24.3	4.0	35.1	29.2
NiCl_2 requires	-	-	54.6	45.4

Although not conclusive, these figures suggest the compound is $\text{NiCl}_2 \cdot 2\text{THF}$, perhaps containing some $\text{NiCl}_2 \cdot \text{THF}$. The complex $\text{NiCl}_2 \cdot 2\text{THF}$ has been reported previously in the form of yellow cubes.²⁵⁸ It could not be prepared by direct reaction of NiCl_2 and THF, but was obtained by replacement of



acetonitrile from a royal blue acetonitrile nickel complex.^{258,259}

2. Nickel complexes + ketimines



Bis(triphenylphosphine)nickel dichloride (1.3 g., 2 mmoles) was placed in a flask and diphenylketimine (0.7 ml., 4 mmoles) was added by syringe. The mixture was stirred for a few minutes, and then THF (20 ml.) was added. The solution immediately looked purple, and all the solid dissolved. After 30 min. the solvent was removed under vacuum, leaving a purple solid, which was washed with ether and pentane to remove PPh_3 . The purple $(\text{Ph}_2\text{C}=\text{NH})_2\text{NiCl}_2$ was recrystallised rapidly from THF/ether, washed with ether and pumped dry. Yield 0.6 g. (60%). M.Pt. 196°C (d).

Found: C, 63.0; H, 4.3; N, 5.2; Cl, 13.7%. $\text{NiC}_{26}\text{H}_{22}\text{N}_2\text{Cl}_2$ requires C, 63.4; H, 4.5; N, 5.7; Cl, 14.4%. The infrared spectrum (Nujol mull) confirmed the absence of PPh_3 and showed absorptions attributable to $\text{Ph}_2\text{C}=\text{NH}$, at 3193(sh), 3175(m), 1597(s), 1562(m), 1351(w), 1266(s), 1252(sh), 1163(m), 1087(sh), 1076(w), 1031(w), 1002(w), 985(w), 943(s), 937(sh), 917(sh), 907(s), 855(sh), 845(w), 795(s), 785(m), 774(sh), 769(s), 726(m), 707(s), 696(vs), 651(s) cm^{-1} .



The nickel dichloride-THF adduct (0.38 g., 1.4 mmoles) was placed in a flask and diphenylketimine (1 ml., 6 mmoles) was added. No reaction occurred on stirring at room temperature. After addition of THF (15 ml.) and slight warming, a blue-violet colour developed in the solvent and a little

purple solid was observed. However, after stirring several hours much $\text{NiCl}_2 \cdot 2\text{THF}$ remained, and the solution was filtered warm. A mixture of purple crystals and a cream solid deposited on cooling, which were identified by infrared spectroscopy as $(\text{Ph}_2\text{C}=\text{NH})_2\text{NiCl}_2$ and $\text{NiCl}_2 \cdot n\text{THF}$, respectively. The two complexes could not be separated, as they have similar solubility properties and the ketimine complex decomposes slowly in solution.

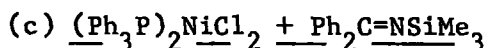

Bis(triphenylphosphine)nickel dichloride (1.9 g., 3 mmoles) was treated with N(trimethylsilyl)diphenylketimine (1.5 ml., 6 mmoles) in one arm of a double Schlenk tube. The dark blue-green mixture was allowed to stir overnight, but no change was observed. Washing with petroleum ether (80-100°) left a dark green solid and combination of the washings and evaporation yielded a yellow oil, shown by infrared spectroscopy to be $\text{Ph}_2\text{C}=\text{NSiMe}_3$. Extraction of the dark green solid with toluene gave a brown violet solution which yielded a small amount of gummy solid. The majority of the green solid which was insoluble in toluene, was shown by infrared spectroscopy to be unreacted $(\text{Ph}_3\text{P})_2\text{NiCl}_2$.

3. Results and Discussion

When the dark blue bis(triphenylphosphine)nickel dichloride complex was treated with THF, displacement of the PPh_3 groups occurred and the cream solid which precipitated consisted of THF adducts of NiCl_2 , mainly $\text{NiCl}_2 \cdot 2\text{THF}$. Reaction in the absence of a solvent between bis(triphenyl-

phosphine)nickel dichloride and diphenylketimine gave the purple complex bis(diphenylketimine)nickel dichloride, $(\text{Ph}_2\text{C}=\text{NH})_2\text{NiCl}_2$. The two complexes were identified by elemental analysis and infrared spectroscopy. However, in the systems $\text{NiCl}_2 \cdot 2\text{THF}/\text{Ph}_2\text{C}=\text{NH}$ and $(\text{Ph}_3\text{P})_2\text{NiCl}_2/\text{Ph}_2\text{C}=\text{NSiMe}_3$ reaction occurred only to a very slight extent.

The factors governing the relative stabilities of octahedral and tetrahedral complexes of Ni^{II} and (Co^{II}) halides with a variety of amines, have been much discussed.^{247,256,260} Both steric and electronic factors are important, the latter including the basicity of the ligand and its π -acceptor properties, as well as the polarisability of the halide. Nickel(II) seems to show a marked preference for an octahedral²⁵⁶, rather than a tetrahedral environment, in contrast to cobalt(II) for which tetrahedral complexes L_2CoX_2 are common.²⁵⁶ The nickel dichloride THF adduct appears from its colour and lack of solubility in solvents other than THF to be polymeric, presumably with chlorine bridges, giving the nickel an octahedral structure. The diffuse reflectance spectrum of $\text{NiCl}_2 \cdot 2\text{THF}$, recorded over the range $25,000 \text{ cm}^{-1}$ to $10,000 \text{ cm}^{-1}$ shows bands at 21,980, $\sim 21,050(\text{sh})$, $\sim 12,900(\text{sh})$ and $11,900 \text{ cm}^{-1}$. Comparison with the spectra of other octahedral Ni^{II} complexes²⁵⁶ (e.g. NiCl_2 : 22,100, $\sim 19,400$, 12,900, $\sim 11,600 \text{ cm}^{-1}$ and NiPy_2Cl_2 : 24,100, $\sim 22,000(\text{sh})$, 13,900, $\sim 12,500(\text{sh}) \text{ cm}^{-1}$) confirms that $\text{NiCl}_2 \cdot 2\text{THF}$ has an octahedral configuration. Bis(triphenylphosphine)nickel dichloride has been shown to be monomeric, with a tetrahedral configuration.²⁵⁷ Further co-ordination of ligands in this complex is probably restricted by

the bulky PPh_3 groups.²⁵⁷ The driving force for the displacement of PPh_3 , which is a strong donor, by the relatively weak donor THF, may be that the resulting compound is polymeric and has nickel in its preferred octahedral environment.

The purple nickel complex $(\text{Ph}_2\text{C}=\text{NH})_2\text{NiCl}_2$ is much less stable in moist air than its cobalt analogue. It is insoluble in hydrocarbon solvents, ether, carbon tetrachloride, but dissolves to some extent in THF and CHCl_3 to give violet and blue solutions respectively. Warming the THF solution causes decomposition with precipitation of a white solid. The diffuse reflectance spectrum of $(\text{Ph}_2\text{C}=\text{NH})_2\text{NiCl}_2$ (recorded in the range 25,000 to 10,000 cm^{-1}) showed bands at 19,460, 16,670(sh), 11,960(sh) $\sim 10,000 \text{ cm}^{-1}$. Comparison with the spectra of other octahedral Ni^{II} complexes of the type $\text{L}_2\text{Ni}^{\text{II}}\text{Cl}_2$ ²⁵⁶ indicates that $(\text{Ph}_2\text{C}=\text{NH})_2\text{NiCl}_2$ has an octahedral configuration. Since other octahedral L_2NiCl_2 complexes e.g. NiPy_2Cl_2 have polymeric structures with chlorine bridges in the solid state²⁵⁶, it seems likely that $(\text{Ph}_2\text{C}=\text{NH})_2\text{NiCl}_2$ has the same structure. On dissolution in chloroform, the chlorine bridges are broken, giving the characteristic blue colour of tetrahedral nickel complexes. The infrared spectrum of $(\text{Ph}_2\text{C}=\text{NH})_2\text{NiCl}_2$ differs noticeably from that of $(\text{Ph}_2\text{C}=\text{NH})_2\text{CoCl}_2$. In particular, $\nu\text{N-H}$ in the nickel complex is much stronger, and the other bands due to co-ordinated diphenylketimine are shifted by varying amounts.

The reluctance of the nickel dichloride THF adduct to react with diphenylketimine reflects the stability of the complex. The almost complete

lack of reaction between $(\text{Ph}_3\text{P})_2\text{NiCl}_2$ and $\text{Ph}_2\text{C}=\text{N}-\text{SiMe}_3$ may be due to the absence of a solvent to act as a source of a proton for $\text{Ph}_2\text{C}=\text{N}^-$, so that the complex $(\text{Ph}_2\text{C}=\text{NH})_2\text{NiCl}_2$ can form. The alternative reaction i.e. elimination of Me_3SiCl (and formation of $(\text{Ph}_2\text{C}=\text{N})_2\text{Ni}(\text{PPh}_3)_2$) seems as unfavourable as it was shown to be in the cobalt system.

D. Cobalt Carbonyls and Ketimines

1. Introduction

The work described in this section concerns the extension of the study of diphenylketimine as a neutral and anionic ligand into the field of metal carbonyl systems. Cobalt carbonyl was chosen as the carbonyl system for investigation for several reasons. Firstly, this study was part of a wider investigation into the reactions of imino compounds with transition metal complexes, especially carbonyl complexes, undertaken by the research group. Several other metal carbonyl systems had already been studied²⁵¹, and the background to these investigations will now be briefly summarised.

The reaction of diphenylketimine with $\text{Mn}(\text{CO})_5\text{X}$ ($\text{X} = \text{Cl}, \text{Br}$) gave the expected disubstituted derivatives $\text{Mn}(\text{CO})_3\text{L}_2\text{X}$. The bromide was also prepared from $\text{Mn}(\text{CO})_5\text{Br}$ and $\text{Ph}_2\text{C}=\text{NSiMe}_3$, although a complex formulated as $\text{Mn}(\text{CO})_n(\text{N}=\text{CPh}_2)$ ($n = 4$ or 5) was obtained from $\text{Ph}_2\text{C}=\text{NLi}$ and $\text{Mn}(\text{CO})_5\text{Br}$. Reaction was shown to occur with heating between $\pi\text{-CpFe}(\text{CO})_2\text{X}$ and $\text{Ph}_2\text{C}=\text{NY}$ ($\text{X} = \text{Cl}, \text{Br}; \text{Y} = \text{MgBr}, \text{Li}$ or Na) but the mixture of products could not be satisfactorily separated and identified. Attempts to initiate reactions between $[\pi\text{-CpMo}(\text{CO})_3]_2$ and azines $[(\text{PhC}(\text{H})=\text{N})_2$ and $(\text{Me}_2\text{C}=\text{N})_2]$ both thermally

and photolytically, were unsuccessful and $\text{Na}[\pi\text{-CpMo}(\text{CO})_3]$ with $\text{Ph}_2\text{C}=\text{NBr}$ gave mainly $[\pi\text{-CpMo}(\text{CO})_3]_2$ with a little $\pi\text{-CpMo}(\text{CO})_3\text{Br}$. However, $\text{Ph}_2\text{C}=\text{NSiMe}_3$ reacts with $\pi\text{-CpMo}(\text{CO})_3\text{Cl}$ to give the dimeric species $[\pi\text{-CpMo}(\text{CO})\text{N}=\text{CPh}_2]_2$ and a little monomer, $[\pi\text{-CpMo}(\text{CO})_2\text{N}=\text{CPh}_2]$.²⁵¹ The analogous monomeric tungsten complex can also be obtained in good yield.²⁶¹ Interestingly, $\pi\text{-CpM}(\text{CO})_3\text{Cl}$ reacts with 2 moles of $\text{Ph}_2\text{C}=\text{NLi}$ to give $\pi\text{-CpM}(\text{CO})_2(\text{Ph}_2\text{CNCPh}_2)$ where $\text{M} = \text{Mo}^{130}$, W^{261} , in which the ligand is thought to be bonding as a pseudo-allylic group. These two complexes will be discussed later. The complex $[(p\text{-CH}_3\text{-C}_6\text{H}_4)_2\text{C}=\text{NFe}(\text{CO})_3]_2$ with bridging ketimino groups (described in Chapter I) was obtained from the corresponding azine and $\text{Fe}(\text{CO})_5$ but the conditions of the reaction were not specified.¹⁸⁵

Another important reason for investigating cobalt carbonyl-imine systems stems from the well known catalytic properties of $\text{Co}_2(\text{CO})_8$. This carbonyl, far more than any other, displays remarkable versatility in catalysing numerous organic reactions¹⁶, including reactions involving carbon-nitrogen and nitrogen-nitrogen unsaturated compounds.³⁶ Many of these reactions involve cyclisation with insertion of carbon monoxide, to give heterocyclic compounds. Examples of the formation of substituted phthalimidines from Schiff bases and aromatic ketoximes (and aldoximes)³⁶ are shown in equations (i) and (ii) respectively.

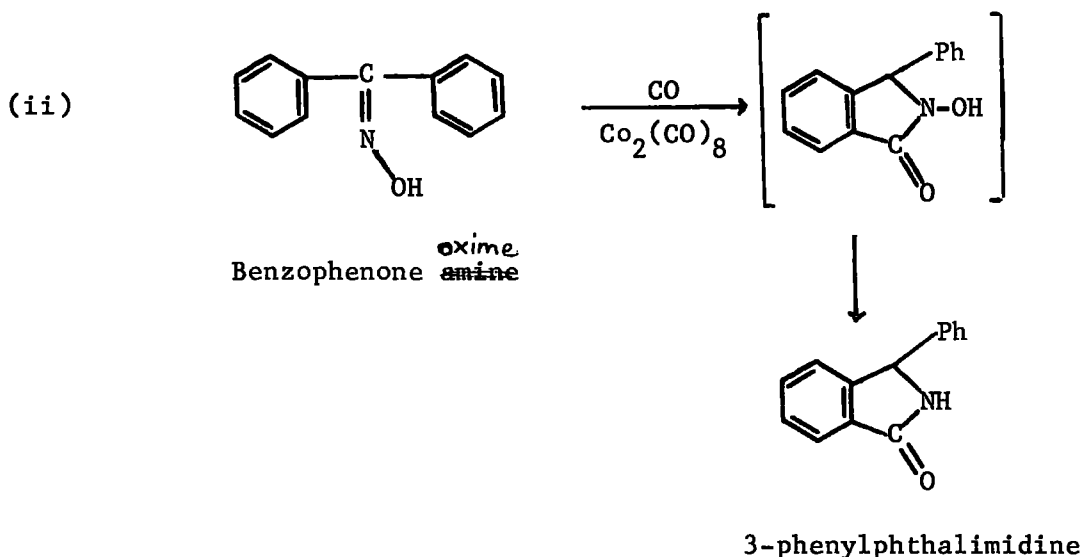
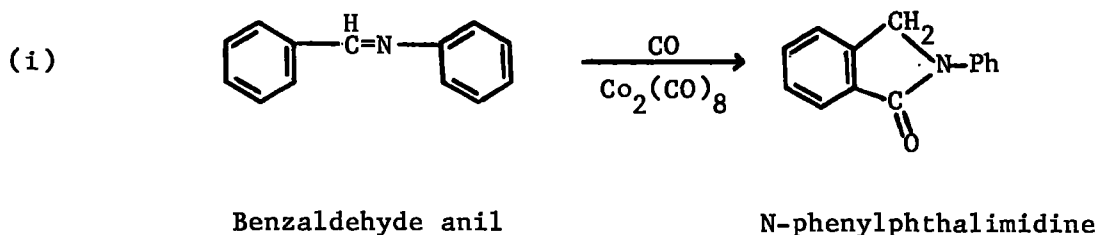

The cobalt carbonyl catalysed reactions are all thought to proceed via initial co-ordination of the organic compound via the nitrogen lone pair, to $\text{Co}_2(\text{CO})_8$ or $\text{HCo}(\text{CO})_4$. A possible mechanism for a cyclisation reaction has already been given in Chapter I (p.18), and it was hoped that isolation of a ketiminocobalt carbonyl derivative might lend support to these ideas.

In many organic syntheses using cobalt carbonyl as catalyst, alkyl or acyl cobalt tetracarbonyl species are thought to be intermediates.¹⁶ Perhaps the best known reaction of this type is the hydroformylation, or oxo reaction in which aldehydes are formed from olefines, carbon monoxide and

2. Experimental

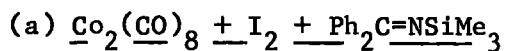

Using the method of Pankowski and Bigorgne²⁶², solutions of dicobalt octacarbonyl (1.3 g., 4 mmoles) and iodine (1 g., 4 mmoles) in cetane (total volume 100 ml.) were mixed, giving a deep yellow-black solution. The reaction was followed by infrared spectroscopy. After 2 hrs., absorptions due to $\text{Co}_2(\text{CO})_8$ and its thermal decomposition product, $\text{Co}_4(\text{CO})_{12}$ were observed, but in addition, a weak band at 2115 cm^{-1} , assigned to $\text{Co}(\text{CO})_4\text{I}$ had appeared. Other absorptions associated with this complex are in a region obscured by $\text{Co}_2(\text{CO})_8$ absorptions. The intensity of this high frequency band did not increase over a further 2 hrs., and, suspecting an equilibrium, N(trimethylsilyl)diphenylketimine (2 ml., 8 mmoles) in centane (5 ml.) was added. Gas evolution was observed and over a period of 73 hrs., $\text{Co}_2(\text{CO})_8$ disappeared; the solution developed a purple blue. $\text{Co}_4(\text{CO})_{12}$ and a new carbonyl species were present in solution. On storing at -20°C , a darkly coloured solid separated out, which was shown by infrared spectroscopy to be a non-carbonyl decomposition product. The carbonyl product could not be isolated from the cetane solution since the solvent could not conveniently be removed under vacuum without heating and thus decomposing the product, (cetane b.pt. 287°C) and solvent extraction with nitromethane and acetonitrile caused decomposition, yielding blue solutions.

Using hexane as the reaction medium, the reaction proceeded as described above, although no band attributable to $\text{Co}(\text{CO})_4\text{I}$ was observed. On cooling

the red-brown solution after filtration, a little red-brown solid deposited, but on warming to room temperature, this turned purple. Sublimation of this solid (at room temperature, 0.001 mm/Hg) was unsuccessful, and the infrared spectrum of the purple solid showed decomposition had occurred. The red-brown mother liquor was reduced in volume, and on cooling, a second red-black precipitate was obtained, whose infrared spectrum showed carbonyl absorptions, and suggested co-ordinated diphenylketimine. Before further measurements could be made, this solid became purple in colour, and further deposits from the mother liquor were also purple.

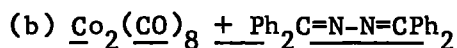

No reaction occurred between equimolar quantities of dicobalt octacarbonyl and benzophenone azine on stirring in pentane at room temperature. Heating caused formation of $\text{Co}_4(\text{CO})_{12}$ as the only new carbonyl species, which was isolated as black needle like crystals. The azine was recovered unchanged. Similarly, no new carbonyl compounds were detected when the reactants, in toluene (in a silica flask) were irradiated. $\text{Co}_4(\text{CO})_{12}$ and unreacted azine were again recovered. The reactions were followed by infrared spectroscopy.

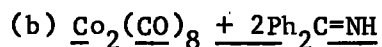

Dicobalt octacarbonyl (1.05 g., 3 mmoles) was dissolved in pentane (30 ml.) in one arm of a double Schlenk tube, and diphenylketimine (1 ml., 6 mmoles), diluted with pentane (8 ml.) was added by syringe. An immediate reaction occurred; vigorous gas evolution was observed and a purple

precipitate formed. After gas evolution had ceased ($\sim\frac{1}{2}$ hr.) the dark yellow mother liquor was removed from the solid by filtration, and the solid washed with pentane until the initially dark yellow washings were colourless. A solution infrared spectrum of the mother liquor and washings showed $\text{Co}_2(\text{CO})_8$ and $\text{Co}_4(\text{CO})_{12}$ to be the only carbonyl species present. The purple powder whose infrared spectrum showed carbonyl groups and co-ordinated ketimine was recrystallised from toluene (at 50°C) yielding dark purple crystals (I), but a second extraction of the crude solid with toluene at 90°C caused decomposition and a black solid was obtained.

Repetition of the reaction by mixing the reactants at -196°C and allowing the mixture to warm up slowly gave the same purple powder. Recrystallisation from monoglyme gave a tar, but with THF/ether, dark purple crystals were obtained. After storing for several days at -20°C , extraction of the crystals with toluene left a pale purple residue (II), which still contained carbonyl and co-ordinated ketimine groups, as shown by infrared spectroscopy. In addition, on prolonged standing, a toluene solution of I deposited pale purple, toluene insoluble crystals of II.

Attempted sublimation of I at room temperature, 0.001 mms/Hg was unsuccessful; at 70°C , the solid gradually became pale grey and the colourless liquid which collected on the cold finger was shown by infrared spectroscopy to be a mixture of diphenylketimine and a little benzophenone.

Since all the $\text{Co}_2(\text{CO})_8$ had not been used up in the previous preparations, the reaction was repeated by adding portions of $\text{Ph}_2\text{C}=\text{NH}$ to the $\text{Co}_2(\text{CO})_8$

solution. Thus, after reaction of $\text{Ph}_2\text{C}=\text{NH}$ (7 mmoles) with $\text{Co}_2(\text{CO})_8$ (3.5 mmoles), the dark yellow mother liquor was removed from the purple precipitate and treated with a further 3 mmoles of $\text{Ph}_2\text{C}=\text{NH}$. Effervescence occurred and more purple precipitate was obtained, and a further 3 mmoles of $\text{Ph}_2\text{C}=\text{NH}$ caused further effervescence and precipitation, leaving an almost colourless mother liquor. Recrystallisation of the precipitates from toluene/pentane gave dark purple crystals of I. On allowing a toluene solution of I to stand for several days, pale purple crystals of II were obtained, which were recrystallised from THF/ether. Analytical Data. I. Found: C, 65.3; 64.5, 62.3; H, 4.06, 3.85, 4.46; N, 6.81%. II. Found: C, 60.3, 55.6; H, 3.7, 4.0; N, 5.0%. $[\text{Co}(\text{Ph}_2\text{C}=\text{NH})_6][\text{Co}(\text{CO})_4]_2$ requires C, 69.9; H, 4.4; N, 5.4%. $[\text{Co}(\text{Ph}_2\text{C}=\text{NH})_4][\text{Co}(\text{CO})_4]_2$ requires C, 64.0; H, 3.9; N, 5.0%. $[\text{Co}(\text{Ph}_2\text{C}=\text{NH})_2][\text{Co}(\text{CO})_4]_2$ requires C, 62.5; H, 2.8; N, 3.7%.

Results and Discussion

Reaction between $\text{Co}_2(\text{CO})_8$ and iodine in cetane solution probably produced a little $\text{Co}(\text{CO})_4\text{I}$, but none could be detected in hexane solution. Addition of $\text{Ph}_2\text{C}=\text{NSiMe}_3$ to these mixtures produced a new carbonyl compound, possibly a ketimino derivative, but its extreme instability has precluded its identification. Attempts to initiate reaction between $\text{Co}_2(\text{CO})_8$ and $\text{Ph}_2\text{C}=\text{N}-\text{N}=\text{CPh}_2$ both thermally and photolytically were unsuccessful. Reaction between $\text{Co}_2(\text{CO})_8$ and $\text{Ph}_2\text{C}=\text{NH}$ gave a toluene soluble cobalt carbonyl diphenylketimine derivative, which on standing changes to a toluene insoluble compound, still containing carbonyl and ketimine groups.

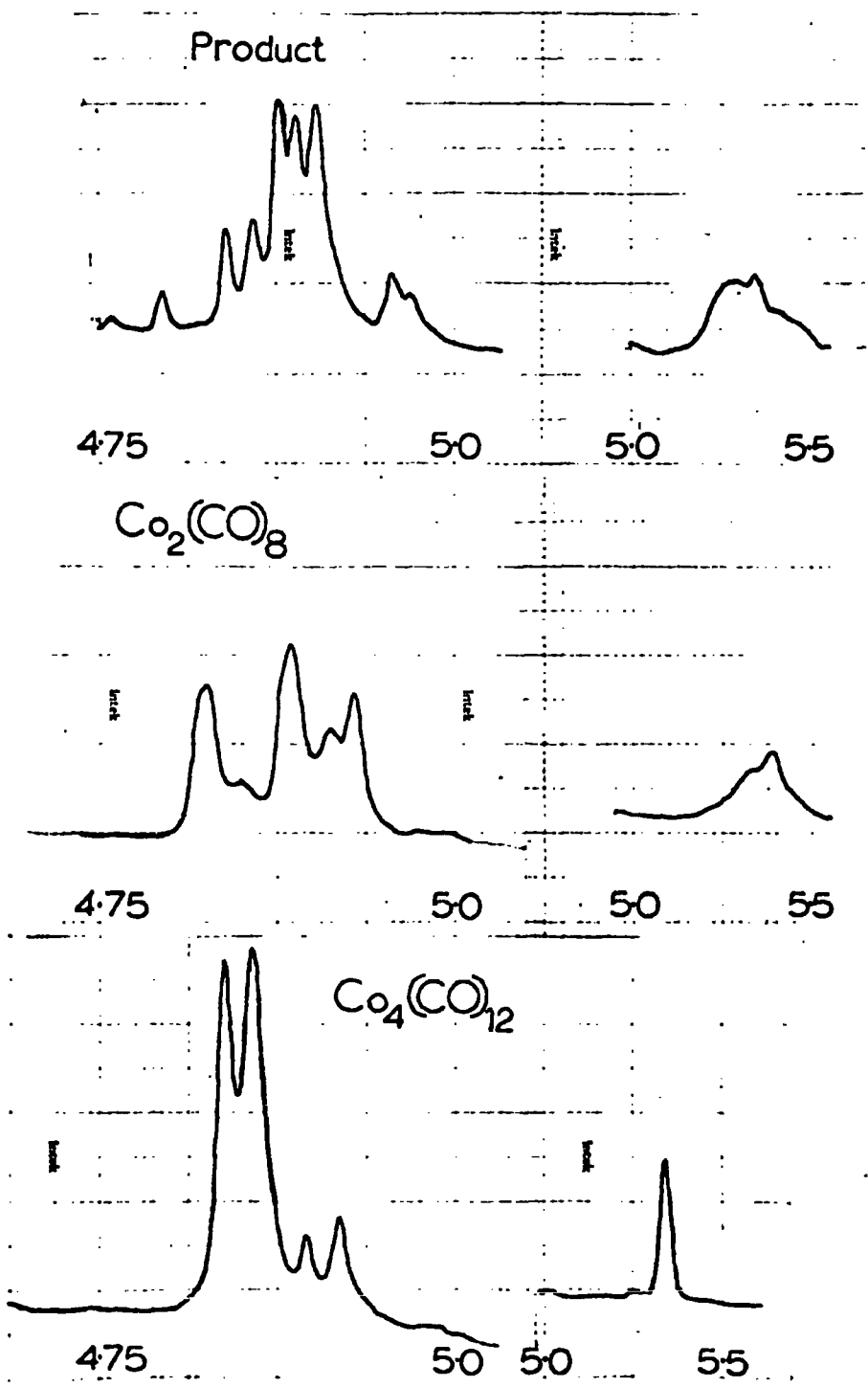

Fig. II.3

Since very little $\text{Co}(\text{CO})_4\text{I}$ could be detected in the reactions between $\text{Co}_2(\text{CO})_8$ and I_2 , it is probable that $\text{Ph}_2\text{C}=\text{NSiMe}_3$ reacted with $\text{Co}_2(\text{CO})_8$. The possibility of the $-\text{SiMe}_3$ fragment bonding to the carbonyl cannot be ignored, especially as many $\text{R}_3\text{SiCo}(\text{CO})_4$ derivatives have been reported. Indeed $\text{Me}_3\text{SiCo}(\text{CO})_4$ ^{263,264} (from Me_3SiH and $\text{Co}_2(\text{CO})_8$) is a volatile pink compound, which decomposes slowly at room temperature in the solid state, but is much more stable in solution. Thus the product of the reaction between $\text{Co}_2(\text{CO})_8$ and $\text{Ph}_2\text{C}=\text{NSiMe}_3$ has similar stability properties to those of $\text{Me}_3\text{SiCo}(\text{CO})_4$. However, infrared evidence suggests that the compound is probably absent; no absorptions due to Me_3Si could be detected, and the spectrum in the carbonyl region differs from that reported for $\text{Me}_3\text{SiCo}(\text{CO})_4$.²⁶⁴ It is possible that the iodine present in solution could have reacted with the Me_3Si fragment to give Me_3SiI , although no evidence for this was obtained. The pentane solution infrared spectrum in the carbonyl region of the product is shown in Fig. II3 together with the spectra of $\text{Co}_2(\text{CO})_8$ and $\text{Co}_4(\text{CO})_{12}$ in pentane. Since overlap of bands due to product and $\text{Co}_4(\text{CO})_{12}$ probably occurs, no deductions about the nature of the product from the positions and relative intensities of its carbonyl stretching frequencies, can be made.

The attempts to initiate reaction between $\text{Co}_2(\text{CO})_8$ and $\text{Ph}_2\text{C}=\text{N}=\text{N}=\text{CPh}_2$, both thermally and photolytically, lead to decomposition of $\text{Co}_2(\text{CO})_8$ to $\text{Co}_4(\text{CO})_{12}$, and recovery of the unreacted azine. It is apparent that conditions necessary to rupture the N-N bond in the azine would be too

severe for the carbonyl, which would decompose before reaction could occur.

Reaction between nitrogen bases and $\text{Co}_2(\text{CO})_8$ normally causes disproportionation to yield salts of the type $[\text{CoL}_n][\text{Co}(\text{CO})_4]_2$ ($n = 4$ or 6 , usually)⁴, as described in Chapter I. However, the product (I) obtained from the reaction of $\text{Co}_2(\text{CO})_8$ with $\text{Ph}_2\text{C}=\text{NH}$ does not appear to be of this type. Its solubility in toluene suggests it is covalent rather than ionic, in nature, but unfortunately attempts to confirm this by conductivity measurements in nitrobenzene solution resulted in decomposition of the compound. A toluene solution of the dark purple complex, I, on prolonged standing deposits pale purple crystals of complex II. Both these complexes contain carbonyl groups and co-ordinated diphenylketimine, as shown by infrared spectroscopy, and both are air-sensitive, complex I being especially so.

Since diphenylketimine seems to behave as a weak base^{240,251}, the expected product from the reaction of $\text{Co}_2(\text{CO})_8$ and $\text{Ph}_2\text{C}=\text{NH}$ is $[\text{Co}^{+II}(\text{Ph}_2\text{C}=\text{NH})_n][\text{Co}^{-I}(\text{CO})_4]_2$. Complex II is tentatively formulated as this type of complex. This is supported by the infrared spectrum (Nujol mull) in the carbonyl region, which shows a very strong, broad peak at 1883 cm^{-1} , but also a shoulder at 1910 cm^{-1} and two very weak bands at 2012 and 2000 cm^{-1} . The strong peak at 1883 cm^{-1} is attributable to $[\text{Co}(\text{CO})_4]^{-4}$ and the other weak bands are perhaps due to impurity. The solubility properties of complex II are consistent with an ionic formulation: it is insoluble in toluene, pentane, ether but soluble in THF and acetone, but attempts to

obtain conductivity measurements in nitrobenzene lead to decomposition. A comparison of the properties of complex II and other compounds of the type $[\text{CoL}_n][\text{Co}(\text{CO})_4]_2$ supports an anionic formulation. These compounds are air sensitive, dark red, and insoluble in hydrocarbon solvents, but soluble in THF and acetone.^{252,253} However, the analytical data obtained on II and reported in the previous section is inconsistent, and does not really support any formulation of this type. The infrared spectrum of complex II shows bands due to co-ordinated ketimine, with $\nu_{\text{N-H}}$ at 3268 cm^{-1} and $\nu_{\text{C=N}}$ at 1607 cm^{-1} .

The nature of complex I is uncertain. Inconsistent analytical data was again obtained, although this data suggests that the % carbon content of the complex falls on changing to complex II. Some of the analytical figures for complexes I and II were obtained on different samples, and it is not clear whether the inconsistencies are due to the samples, or to the unreliability of the analytical methods for complexes of this type.

Complex I is insoluble in pentane, but readily soluble in toluene and extremely soluble in THF, monoglyme and acetone, and is thus probably not ionic. The infrared spectrum (Nujol mull) in the carbonyl region shows a weak band at 2008 cm^{-1} and a strong broad band resolved into 3 maxima at 1905, 1869 and 1842 cm^{-1} . In addition bands attributable to co-ordinated $\text{Ph}_2\text{C=NH}$ are observed, with $\nu_{\text{N-H}}$ at 3257 cm^{-1} and $\nu_{\text{C=N}}$ at 1605 and 1594 cm^{-1} . Complexes of the type $[\text{Co}(\text{CO})_3\text{L}]_2$ with e.g. PPh_3 have been obtained by direct reaction of the ligand with $\text{Co}_2(\text{CO})_8$. The carbonyl pattern in the infrared spectrum of $[\text{Co}(\text{CO})_3\text{PPh}_3]_2$ is similar to that observed for complex I

(bands at 2030(vw), 1960m,(sh), 1950(vs), 1902(vw)) although the absorptions in I are considerably shifted to lower frequencies. However, a formulation of the type $[\text{Co}(\text{CO})_3\text{Ph}_2\text{C}=\text{NH}]_2$ would not account for the fact that 4 moles of $\text{Ph}_2\text{C}=\text{NH}$ were required to react completely with 2 moles of $\text{Co}_2(\text{CO})_8$.

Attempts were made to obtain a mass spectrum of complex I. A peak at m/e 180 was observed, due to $\text{Ph}_2\text{C}=\text{N}^+$ and several peaks to higher m/e , but no parent peak could be identified.

Thus reaction between $\text{Co}_2(\text{CO})_8$ and $\text{Ph}_2\text{C}=\text{NH}$ occurs to produce a purple complex which is probably of the type $[\text{CoL}_n][\text{Co}(\text{CO})_4]_2$ ($n = 4 ?$). An intermediate complex is isolated initially in the reaction, which changes into the ionic complex, but the nature of the intermediate could not be determined.

Conclusions

Reactions of diphenylketimine and its derivatives with non-carbonyl cobalt and nickel systems show that the neutral ligand behaves as a normal base towards transition metals. Attempts to introduce diphenylketimine as an anionic ligand into complexes were unsuccessful; in some cases, reaction did not occur, in other cases non-crystallisable tars were obtained, and in other reactions, the anion abstracted hydrogen, possibly from the solvent to yield complexes containing the neutral ligand.

In cobalt carbonyl systems, reaction occurs between the carbonyl and ligand, but in one case the product was extremely thermally unstable, and in the other, full characterisation of the products has not been possible.

CHAPTER THREE

Reactions of Diphenylketiminodiphenylmethylchloride with
Transition Metal Complexes

A. Introduction

The evident unwillingness of diphenylketimine to form isolable derivatives containing the ligand as an anionic group, in the systems described in Chapter II lead to a change of emphasis in the study of unsaturated nitrogen ligands with transition metals. The change was particularly encouraged by the preparation of the pseudo allyl complex $[\pi\text{-CpMo(CO)}_2\text{Ph}_2\text{CNCPh}_2]^{130}$ by an indirect route. This chapter describes attempts to prepare analogous compounds directly from diphenylketiminodiphenylmethyl chloride, $\text{Ph}_2\text{C=NC(Cl)Ph}_2$, which was prepared from diphenylketiminolithium, $\text{Ph}_2\text{C=NLi}$ and dichlorodiphenylmethane.^{267,268}

It is believed that the $\text{Ph}_2\text{CNCPh}_2$ group in the molybdenum complex is bonding to the metal as a pseudo-allyl group¹³⁰ and since this chapter is concerned with the attempted preparation of pseudo-allyl complexes, it is relevant at this stage to comment on the chemistry of transition metal allyl complexes themselves. Numerous complexes are known and several reviews have appeared.^{269,270,271} Pure π -allyl complexes have been prepared for several metals e.g. $(\pi\text{-C}_3\text{H}_5)_2\text{Ni}$, $(\pi\text{-C}_3\text{H}_5)_4\text{Mo}$, but the majority of the derivatives contain other groups also, e.g. $\pi\text{-C}_3\text{H}_5\text{Mo(CO)}_2\pi\text{-C}_5\text{H}_5$, and $\pi\text{-C}_3\text{H}_5\text{Co(CO)}_2\text{PPh}_3$. π -allyl derivatives in which one or more of the protons is replaced by other groups e.g. alkyl groups or halogens are also common, e.g. $\pi\text{-C}_5\text{H}_9\text{Mn(CO)}_4$, 1,1-dimethylallylmanganese tetracarbonyl. The π -allyl group need not be "free" but can be part of a ring system or a long chain of carbon atoms. Examples of these types of compound are shown in Figs. III.1 and III.2.

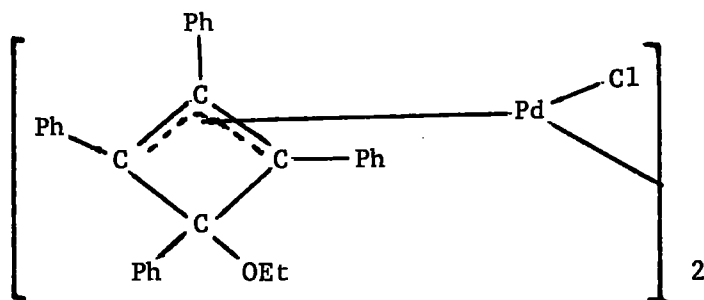

Fig. III.1.



Fig. III.2.

Several π -allyl derivatives have versatile catalytic properties e.g. $\text{Ni}(\pi\text{-C}_3\text{H}_5)_2$ catalyses the trimerisation of butadiene to cyclododecatriene, and a mixture of $(\pi\text{-C}_3\text{H}_5)\text{Ni}(\text{Br})\text{PR}_3$ and EtAlCl_2 catalyses the dimerisation of ethylene to butene.²⁷¹

The bonding in π -allyl transition metal complexes can be understood fairly readily in a qualitative manner. The 3 carbon atoms of the π -allyl group form an isosceles triangle with the metal atom in a plane perpendicular (or nearly so) to the plane of the triangle. This is illustrated schematically for the bis-2-methylallyl nickel complex Fig. III.3.

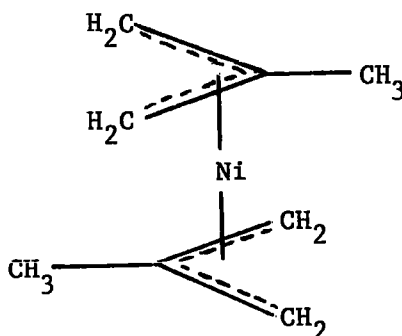

Fig. III.3.

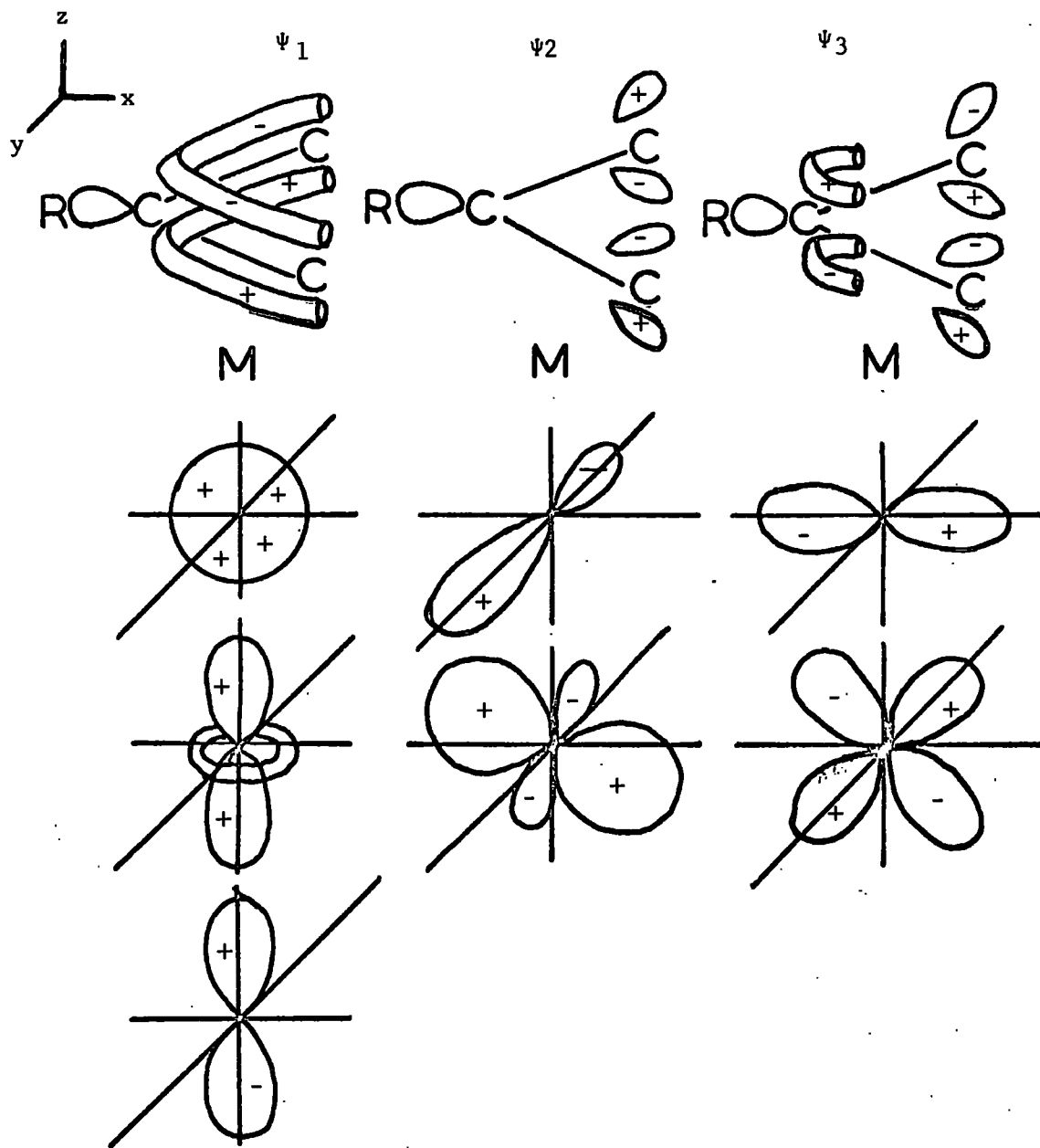

Fig. III.4.

Representation of π -allyl molecular orbitals, and the metal orbitals with which they are most likely to interact to give substantial metal-allyl bonding.

The three π orbitals of the allyl group form three M.O.s, which are represented in Fig.III.4, together with the metal orbitals with which they are most likely to interact, to give substantial metal-allyl bonding. These combinations are arrived at mainly from overlap considerations, in a rough, pictorial manner, since the local symmetry of the π -C₃H₅-M is very low (C_s) and symmetry arguments alone lead to a large number of possible combinations. For example, the d_{xy} and $d_{x^2-y^2}$ orbitals lie in a plane below the allyl plane (i.e. they are not directed towards the ligand) and are likely to be non-bonding. Further distinctions are made on the basis that metal and ligand orbitals having coincident nodal planes are more likely to have a larger overlap than those which do not coincide.

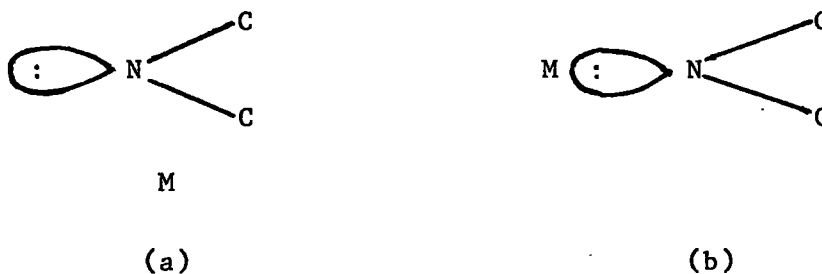
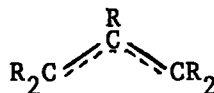

Fig.III.5.

Considering a pseudo-allylic ligand, replacement of a nitrogen atom for the central -CR- group in the allylic group



will not alter

qualitatively the π -molecular orbitals of the allylic group. However the nitrogen possesses a lone pair of electrons which will be in an sp^2 orbital,

directed as shown in Fig.III.5, and the effect of the lone pair on the bonding must be considered. Two extreme positions for the metal are shown in Fig. III.5. In structure (a) it will be readily seen, that the bonding is analogous to that in the allyl complexes described above. In structure (b) the nitrogen lone pair σ -bonds to the metal, but suitable metal orbitals are still available to overlap with the Ψ_1 and Ψ_3 π -molecular orbitals of the pseudo-allylic ligand.

If other complexes containing the $-RC=NR$ system are considered, then it is obvious that either an M-N σ bond can be formed, as for example, in the diazabutadiene molybdenum complexes^{125,126} described in Chapter I (p.35), or π -bonds are formed as in the iron complex $(PhCH=CH-CH=NPh)FeCO_3$ ²⁴, whose structure is shown in Chapter I (p.63, Fig.I.11k(i)). The structure of the nickel complex $[Ni(C_5H_{10}N-C=N)(CO)]_3$ ²³² has also been described in Chapter I (p.80, Fig.I.17). In this complex, the lone pair on the $-C=N$ nitrogen atom σ -bonds to one Ni atom, and the $-C=N$ group π -bonds to another Ni atom.

A few N-heterocyclic analogues of π -cyclopentadienyl metal complexes have been prepared, but they are in general much less stable than the cyclopentadienyl complexes, and more difficult to prepare. This is probably because the π -system of the ring is distorted by the presence of an electronegative nitrogen atom and less available for symmetrical bonding to the metal, so that the M-L π -bond is weaker. The compounds shown in Figs.III.6 and III.7, π -pyrrolylmanganese tricarbonyl¹⁷⁵ and azaferrocene¹⁷⁶, respectively both have similar physical properties to those of the parent π -cyclopenta-

dienyl complexes, but the nitrogen atom in the C_4H_4N ring is only weakly basic. This suggests that the lone pair on the nitrogen is to some extent involved in M-L bonding. The lone pair is in an orbital which is coplanar with the ring and thus directed away from the metal, as would be the case for a pseudo-allyl complex having the structure shown in Fig.III.5(a).

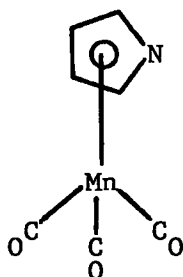

Fig.III.6.

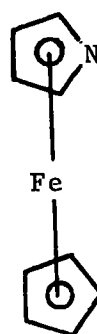
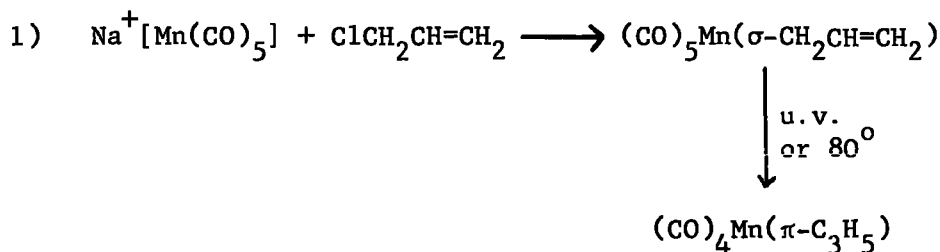

Fig.III.7.

Thus by comparison with other complexes, it would appear that the metal could be in either of the positions indicated in Fig.III.5. A position intermediate between the two extremes may be more likely, in which the metal atom is nearer to the nitrogen, rather than the carbon atoms, because of involvement of the nitrogen lone pair. It is likely that the substituents on the carbon atoms will have some effect on the position of the metal, bulky groups tending to force the metal nearer to the nitrogen. This will be discussed in Section C.

The tungsten pseudo-allyl complex $[\pi\text{-CpW}(\text{CO})_2\text{Ph}_2\text{CNCPh}_2]$ ²⁶¹ has been prepared by the reaction of $\pi\text{-CpW}(\text{CO})_3\text{Cl}$ with 2 moles of $\text{Ph}_2\text{C=NLi}$, and is similar to the very stable molybdenum complex.¹³⁰ In the reaction, two molecules of $\text{Ph}_2\text{C=NLi}$ must "condense" in some manner, to give the $\text{Ph}_2\text{CNCPh}_2$ moiety. The nitrogen atom which is eliminated in this process has been detected as lithium isocyanate, which is mixed with the lithium chloride which precipitates out during the reaction.²⁶¹ Attempts to prepare the pseudo-allyl molybdenum compound by reacting $\text{Ph}_2\text{C=N-C(Cl)Ph}_2$ with $\text{Na}[\pi\text{-CpMo}(\text{CO})_3]$ in THF, dimethyl formamide and diglyme gave $[\pi\text{-CpMo}(\text{CO})_3]_2$ as the main product, and most of the organic ligand was recovered unchanged. Small amounts of at least one other carbonyl complex were detected but could not be isolated.²⁵¹

Two general methods of preparation were used in attempts to synthesise pseudo-allyl compounds directly from $\text{Ph}_2\text{C=N-CPh}_2\text{Cl}$. The ligand itself was reacted with several metal carbonyl and non-carbonyl derivatives; analogous reactions of allyl halides have yielded numerous π -allyl complexes, and some of these reactions are illustrated in the following schemes (equations 1-3)^{269,271}:



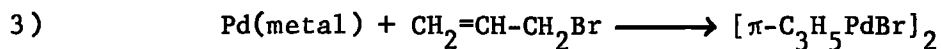
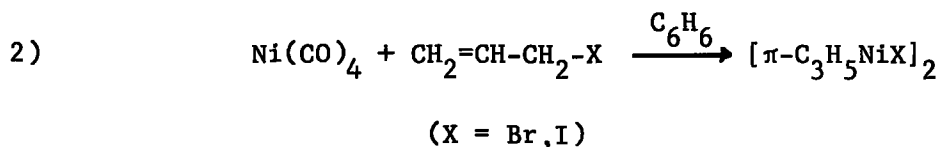

The second method of preparation used involved synthesis of the Grignard derivative of the ligand, $(\text{Ph}_2\text{CNCPh}_2)\text{MgCl}$, and reaction of this with a variety of transition metal systems. Again allyl Grignard reagents have been used to prepare allyl-transition metal complexes, as illustrated in the following schemes (equations 4 and 5):^{269,271}

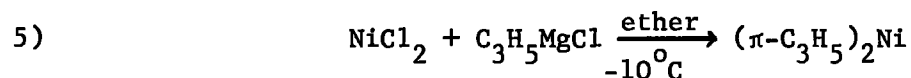
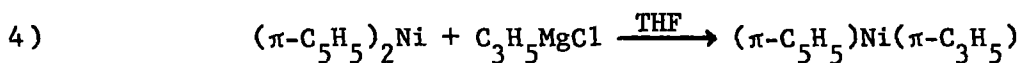

Since the direct reaction between $\text{Ph}_2\text{C}=\text{N}-\text{C}(\text{Cl})\text{Ph}_2$ and $\text{Na}[\pi\text{-CpMo}(\text{CO})_3]$ failed to produce the pseudo-allyl derivative²⁵¹, attention was focussed on other metals. In particular, the reactions of $\text{Ph}_2\text{C}=\text{N}-\text{C}(\text{Cl})\text{Ph}_2$ with manganese carbonyl derivatives, and with some nickel complexes were investigated, as allyl compounds of both these systems have been prepared. Allyl-nickel complexes especially are common, and have been prepared in a variety of ways. Another consideration in choosing which metal to study was that the metals towards the left-hand side of the Periodic Table tend to form more stable complexes with nitrogen-containing ligands than the ones towards the right-hand side. In particular manganese (+I) complexes in general seem especially stable.

B. Experimental

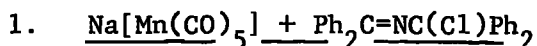

Sodium manganese pentacarbonyl was prepared in the usual way, by vigorously stirring dimanganese decacarbonyl (1 g., 2.5 mmoles) with an excess of an approximately 1% sodium amalgam in THF (20 ml.).²⁷² When the yellow colour of $\text{Mn}_2(\text{CO})_{10}$ disappeared (2 hrs.), most of the amalgam was removed from the reaction flask via a tap at the bottom, and diphenylketiminodiphenylmethyl chloride (1.9 g., 5 mmoles), in THF (15 ml.) was added. After overnight stirring and then refluxing for 5 hrs., solution i.r. spectroscopy showed that the main carbonyl product was manganese carbonyl, but new absorptions were detected at 2110, 2062 and 2026 cm^{-1} . Both $\text{Mn}_2(\text{CO})_{10}$ (~20%) and $\text{Ph}_2\text{C}=\text{N}-\text{C}(\text{Cl})\text{Ph}_2$ (~40%) were recovered, but all attempts to isolate the product failed, since it appeared to decompose into $\text{Mn}_2(\text{CO})_{10}$ in solution.

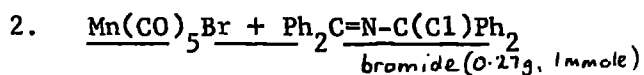

Manganese pentacarbonyl was dissolved in chloroform (6 ml.). Diphenylketiminodiphenylmethyl chloride (0.38 g., 1 mmole) was dissolved in chloroform (12 ml.) and a third of this solution (0.33 mmoles $\text{Ph}_2\text{C}=\text{N}-\text{C}(\text{Cl})\text{Ph}_2$) added to the carbonyl solution. The reaction was followed by withdrawing samples of the solution periodically, and recording their infrared spectra in the carbonyl region. After stirring at room temperature for 3½ hrs. (protected from the light) a small amount of white precipitate was observed and new carbonyl bands were detected, but the bulk of the $\text{Mn}(\text{CO})_5\text{Br}$ remained. The

washed rapidly with hexane and pumped dry. (Yield, 0.2 g.). This compound was shown to be tetraphenylethylene, on the basis of analytical and infrared spectroscopic data. Found: C, 94.9, 93.9%. Average C, 94.4%. H, 5.1%. $C_{26}H_{20}$ requires C, 94.0; H, 6.0%. M.Pt. $218^{\circ}C$ (lit. $223^{\circ}C$). The infrared spectrum (Nujol mull) was identical to the spectrum of an authentic sample.

The residue after ether extraction was pale brown in colour and elemental tests showed the presence of nickel and chlorine. The infrared spectrum of the residue showed only weak absorptions.

(b) In a repeat of the reaction, removal of the solvent after overnight stirring left a black tar, from which unreacted nickelocene ($\sim 50\%$) was recovered by sublimation (at $50^{\circ}C$, 0.001 mm/Hg). Ether extraction yielded a yellow solid which was shown to contain nickel (by elemental tests). Analytical and spectroscopic data suggested that this compound contains organic ligands bonded to nickel. It does not contain halogen, nor a π -cyclopentadienyl group.

(c) No reaction occurred between nickelocene and diphenylketimino-diphenylmethyl chloride on stirring in toluene for 16 hrs. The organic compound can be recrystallised from chloroform without decomposition, and a green solution of nickelocene in chloroform showed no change over a period of 5 days.

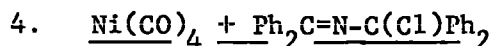

Diphenylketiminodiphenylmethyl chloride (1 g.) was dissolved in toluene (30 ml.) to give a yellow solution. Tetracarbonyl nickel, after

being dried by standing over anhydrous CuSO_4 , was condensed out of a stream of nitrogen onto the $\text{Ph}_2\text{C}=\text{NC}(\text{Cl})\text{Ph}_2$ solution by cooling the latter to -78°C (M.Pt. $\text{Ni}(\text{CO})_4$ -18.9°C). Excess $\text{Ni}(\text{CO})_4$ was used in each reaction, the exact quantity not being determined due to the difficulties of handling the extremely volatile, toxic carbonyl. No change was observed at room temperature, but on careful warming to $\sim 40^\circ\text{C}$, considerable darkening in colour of the solution and a black precipitate were observed after ~ 30 mins. After 5 hrs., no further change was observed and after cooling, the solution was flushed out with nitrogen to remove any unreacted $\text{Ni}(\text{CO})_4$. The black residue after filtration was finely divided Ni. The red filtrate yielded a red solid which yielded pale yellow crystals on recrystallisation from toluene/hexane. Analytical and infrared spectroscopic data suggested that the crystals consisted of $\text{Ph}_2\text{C}=\text{N}-\text{C}(\text{Cl})\text{Ph}_2$ and $\text{Ph}_2\text{C}=\text{CPh}_2$.

Results and Discussion

Reactions of diphenylketiminodiphenylmethyl chloride with sodium manganese pentacarbonyl and with manganese pentacarbonyl bromide have been studied. The main product in the reaction of the sodium salt is the dimer, $\text{Mn}_2(\text{CO})_{10}$, although a new carbonyl species was detected spectroscopically. Separation of this species from $\text{Mn}_2(\text{CO})_{10}$ could not be effected, since it seemed to decompose into $\text{Mn}_2(\text{CO})_{10}$ in solution. Warming a chloroform solution of $\text{Ph}_2\text{C}=\text{NC}(\text{Cl})\text{Ph}_2$ and $\text{Mn}(\text{CO})_5\text{Br}$ caused reaction to occur, with formation of the complex $\text{Mn}(\text{CO})_4(\text{Ph}_2\text{CNCPh}_2)$.

In the reactions of nickelocene and nickel tetracarbonyl with diphenyl-

ketiminodiphenylmethyl chloride, no fully characterised complexes containing nickel and the organic ligand could be obtained. In each case, though, the information obtained shows that, in the former case at least, reaction did occur.

In the reaction of $\text{Na}[\text{Mn}(\text{CO})_5]$ with $\text{Ph}_2\text{C}=\text{N}-\text{C}(\text{Cl})\text{Ph}_2$, a considerable quantity of $\text{Mn}_2(\text{CO})_{10}$ was detected quite early during the reaction, while some unreacted sodium salt and organic ligand were still present, and it seems likely that formation of the dimeric carbonyl directly from the sodium salt is the main reaction. However, a small amount of a new carbonyl complex was detected spectroscopically after refluxing the mixture; removal of $\text{Mn}_2(\text{CO})_{10}$ and $\text{Ph}_2\text{C}=\text{N}-\text{C}(\text{Cl})\text{Ph}_2$ by extraction with hexane and toluene, respectively left a small amount of green solid which gave a green solution when dissolved in CHCl_3 . However, the infrared spectrum of this solution which turned yellow on standing, showed $\text{Mn}_2(\text{CO})_{10}$ to be present as well as the new carbonyl complex, indicating that the complex decomposes to $\text{Mn}_2(\text{CO})_{10}$ in solution, and satisfactory purification of this small amount of product could not be achieved.

This reaction can be compared to that between $\text{Na}[\pi\text{-CpMo}(\text{CO})_3]$ and $\text{Ph}_2\text{C}=\text{N}-\text{C}(\text{Cl})\text{Ph}_2$ ²⁵¹, where the main reaction was decomposition of the sodium salt to the dimer, $[\pi\text{-CpMo}(\text{CO})_3]_2$, although a new carbonyl complex in small amounts was detected spectroscopically.

Warming a chloroform solution of $\text{Mn}(\text{CO})_5\text{Br}$ and $\text{Ph}_2\text{C}=\text{N}-\text{C}(\text{Cl})\text{Ph}_2$ gave a new carbonyl complex, $\text{Mn}(\text{CO})_4(\text{Ph}_2\text{CNCPh}_2)$, obtained as a pale yellow powder.

The complex decomposed fairly rapidly in solution to a white non-carbonyl material, but is stable for longer periods in the solid state. It did not melt, but on being heated in a tube sealed under nitrogen, it began to darken at $\sim 80^{\circ}\text{C}$ and continued to darken and soften to a dark orange tar, up to 200°C . It is very soluble in CHCl_3 , acetone, somewhat soluble in benzene and toluene and slightly soluble in pentane.

The bands in the infrared spectrum of the solid are recorded in Table III.1, together with those of $\text{Ph}_2\text{C}=\text{N}-\text{C}(\text{Cl})\text{Ph}_2$ and known assignments. A CHCl_3 solution of the complex shows carbonyl absorptions at 2104(w), 2033(s), 2020(sh), $1965(\text{s})\text{ cm}^{-1}$. These band positions can be compared to the carbonyl absorptions of $(\pi\text{-C}_3\text{H}_5)\text{Mn}(\text{CO})_4$, which occur at 2110, 2060, 2049 and 1950 cm^{-1} .²⁷⁴ The absence of a C=N stretching frequency and of the doublet assigned to $\nu_{\text{C}-\text{Cl}}$ in $\text{Ph}_2\text{C}=\text{N}-\text{C}(\text{Cl})\text{Ph}_2$ ²⁶⁸ is noteworthy. The pattern of absorptions due to the ligand is considerably simplified in the spectrum of the complex.

A p.m.r. spectrum of $\text{Mn}(\text{CO})_4(\text{Ph}_2\text{CNCPh}_2)$, obtained in CDCl_3 after accumulating 25 times using a Digico C.A.T., consists of two multiplets centred at $2.6\ \tau$ and $2.9\ \tau$, relative to TMS (internal standard). $\text{Ph}_2\text{C}=\text{N}-\text{C}(\text{Cl})\text{Ph}_2$ in CDCl_3 shows two strong multiplets centred at $2.6\ \tau$ and $3.0\ \tau$ and a weaker multiplet centred at $3.5\ \tau$, relative to TMS (internal standard). The signals in each spectrum were too close together for a satisfactory integration to be obtained.

Repeated attempts to obtain a mass spectrum of $\text{Mn}(\text{CO})_4(\text{Ph}_2\text{CNCPh}_2)$ using

Table III.1.

Infrared Spectra of $\text{Mn}(\text{CO})_4(\text{Ph}_2\text{CNCPh}_2)$ and $\text{Ph}_2\text{C}=\text{NC}(\text{Cl})\text{Ph}_2$ (Nujol mull)

$\text{Mn}(\text{CO})_4(\text{Ph}_2\text{CNCPh}_2)$ cm^{-1}	$\text{Ph}_2\text{C}=\text{NC}(\text{Cl})\text{Ph}_2$ cm^{-1}	Assignment ^{268,273}
2095(w)		CO
2025(s, br)		CO
1938(s)		CO
1919(s, sh)		CO
1595(m)	1623(m)	C=N
1575(m)	1597(m)	C=C (of aromatic
1493(sh)	1575(m)	C=C nuclei)
1447(sh)	1490(sh)	} Phenyl nuclei
1323(m)	1449(sh)	
	1314(w)	
	1280(m)	
1263(w)	1269(m, sh)	
	1193	} In Plane Bending of Phenyl Groups
	1183	
1178 (w)	1175 (m)	
1160 (w)	1160	
	1151	
1093(w, sh)	1085	
1075(m)	1075 (w)	
1029(m)	1031 (m)	
	1022	
	1008	
1000(vw)	1002 (w)	
983(w)	995	
957(m)	973(m)	
909(w)	894(w)	
800(m, br)	845(vw)	} Out of Plane Bending
	787(m)	
775(m)	769(s)	
762(s)	751(sh)	
746(m)	745(s)	
725(w)	730	} C-Cl
	724 (s, split)	
698(vs)	696(vs)	} Out of Plane Bending
693(vs)		
667(m)	667(m)	
655(m)		
647(w)	637(w)	} MCO bend
626(m)	628(w)	
614(w)	616(w)	
	600(s)	
570(m)	589(w)	

the direct insertion probe and varying the source temperature at insertion from room temperature to 200°C were unsuccessful. No metal-containing peaks could be detected, but peaks due to fragmentation of the organic ligand were observed. In the mass spectrum of $\text{Ph}_2\text{C}=\text{N}-\text{C}(\text{Cl})\text{Ph}_2$, no parent peak is observed; the highest mass peak is at m/e 346, corresponding to $[\text{Ph}_2\text{CNCPh}_2]^+$.²⁶⁸ This peak is not, however, observed in the spectrum from $\text{Mn}(\text{CO})_4(\text{Ph}_2\text{CNCPh}_2)$; the highest intense peak was observed at m/e 180, corresponding to $[\text{Ph}_2\text{CN}]^+$. The spectrum of $\text{Ph}_2\text{C}=\text{N}-\text{C}(\text{Cl})\text{Ph}_2$ also contains a peak at m/e 332, corresponding to $[\text{Ph}_2\text{CCPh}_2]^+$. This has been attributed²⁶⁸ to an impurity, rather than due to breakdown of $\text{Ph}_2\text{C}=\text{N}-\text{C}(\text{Cl})\text{Ph}_2$, but the peak also occurs in the mass spectra of $\text{Mn}(\text{CO})_4(\text{Ph}_2\text{CNCPh}_2)$ and it is possible that it arises from thermal decomposition of the complex.

Molecular weight determinations could not be made on the complex since it is too unstable in solution for ebullioscopic measurements, and not soluble enough in suitable solvents for cryoscopic measurements.

The information obtained on this complex is consistent with the formulation $\text{Mn}(\text{CO})_4(\text{Ph}_2\text{CNCPh}_2)$. The spectra data on the complex, when compared to that of the parent ligand, suggests that the phenyl groups in the complex are all in a similar chemical environment. The ligand can be regarded as donating 3 electrons to the metal. Several types of metal-ligand bonding can be envisaged for this complex, and some of them are represented schematically in Fig.III 8.

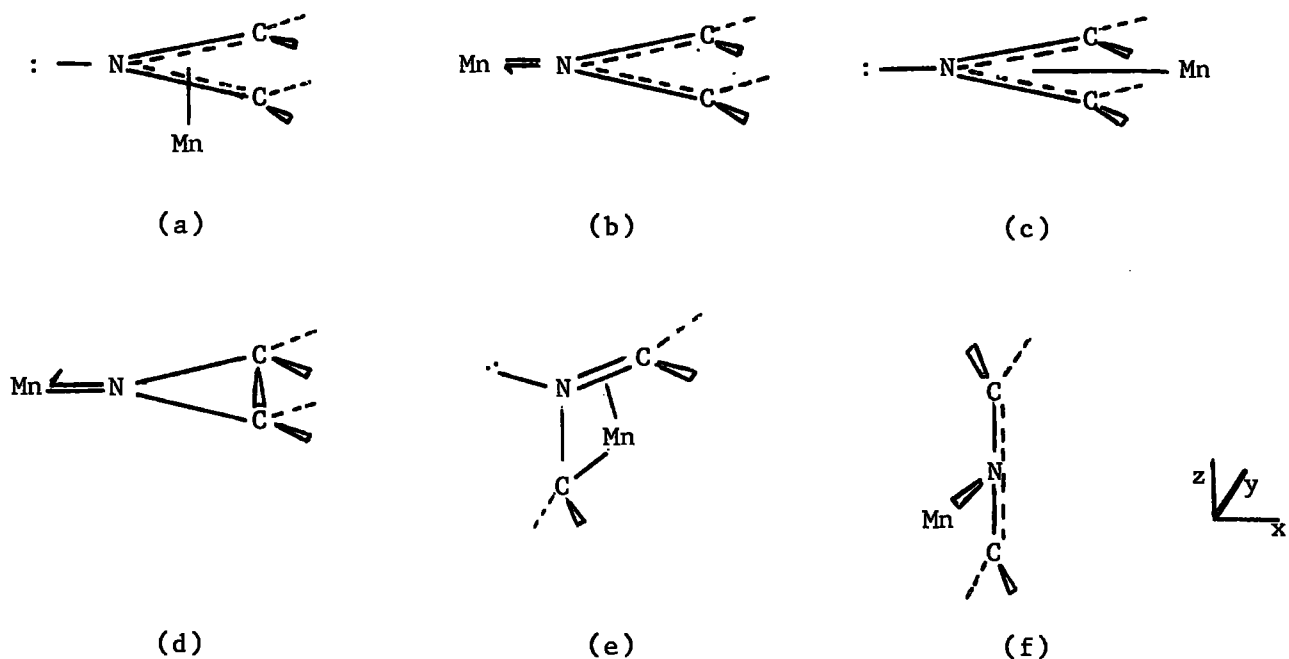

Fig. III.8.

The first two possibilities, (a) and (b), represent the extremes described in Section A of this chapter, for a pseudo-allylic ligand, while (c) shows the same arrangement of atoms in the ligand, but the metal, in the same plane as the CNC skeleton, is between the two carbon atoms, interacting only with the π -orbitals of the ligand, and not with the nitrogen lone pair. If a bond forms between the two carbon atoms of the ligand, then the ligand is a substituted aziridine. In this case, the metal would bond only to the nitrogen and the ligand could formally donate 3 electrons to the metal through σ - and π -bonds involving nitrogen sp hybrid and p_z orbitals respectively. In (e), the metal forms a normal σ -bond with one carbon atom, and interaction

between the CN double bond and the metal also occurs. The nitrogen lone pair will play no part in M-L bonding. The possibility that the CNC skeleton may be linear, with an sp hybridised N atom must be considered (Fig.III.8f). Relative to the axes shown, the nitrogen lone pair would occupy a pure p_y orbital, and the p_x orbitals on the two carbon and the nitrogen atoms would be available for formation of 3 π -orbitals. Thus, M-L bonding could occur via donation of the nitrogen lone pair to the metal, and overlap of suitable metal orbitals with the π - or π^* -orbitals of the ligand.

Although a definite answer to the problem of the bonding in the complex $Mn(CO)_4(Ph_2CNCPh_2)$ (and in the related complex $[\pi-CpMo(CO)_2(Ph_2CNCPh_2)]^{130}$) must await an X-ray crystal structure study, some of the structures briefly described are less likely than others. A study of molecular models of the ligand containing an sp or sp^2 hybridised nitrogen atom show that the bulky phenyl groups make the nitrogen atom very crowded. A photograph of a model of the ligand with sp^2 hybridised N is included. Consideration of the model suggests that structures (c) and (e) in Fig.III.8 are extremely unlikely, since the phenyl groups would prevent the metal approaching the CNC skeleton near enough for bond formation. Of the other possibilities, (b) and (d) have the metal well removed from the phenyl groups, and on steric grounds anyway, are perhaps the most likely structures.

A structure of type (e) is probably unlikely, since the spectroscopic evidence on the complex suggests that the four phenyl groups are all in a similar chemical environment. Structures (a)-(f) imply a C-N bond order

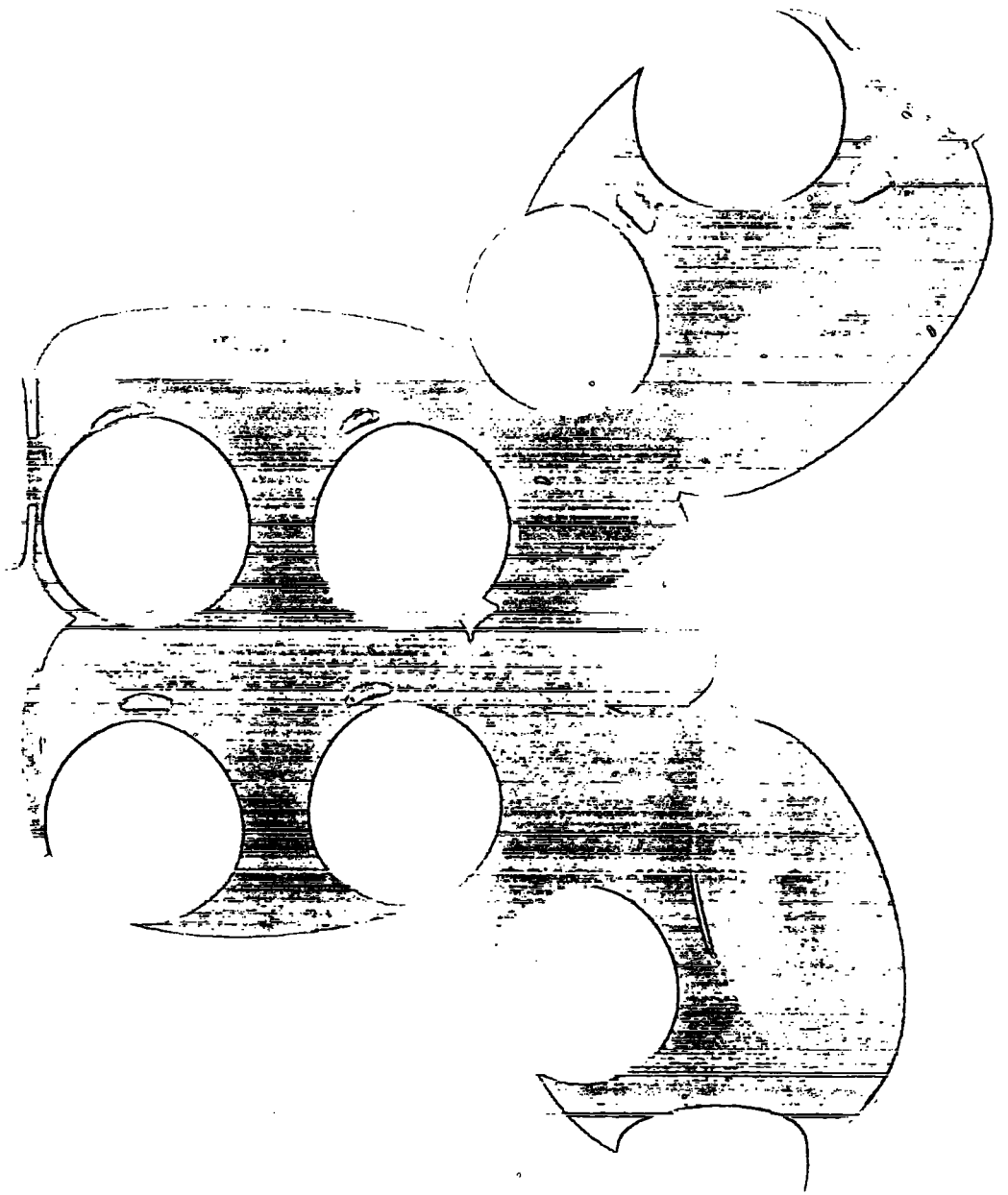

between 1 and 2 and an infrared absorption due to the delocalised C-N stretch would be expected in the region 1600 to 1360 cm^{-1} .²⁷³ Indeed, bands at 1458 cm^{-1} and 1505 cm^{-1} in the spectra of $[(\pi\text{-C}_3\text{H}_5)\text{PdCl}]_2$ ²⁶⁹ and $(\pi\text{-C}_3\text{H}_5)\text{Mn}(\text{CO})_4$ ²⁷⁴ respectively have been attributed to the delocalised C-C stretch, and replacement of C by N seems to make little difference to the positions of $\nu_{\text{C-C}}$ and $\nu_{\text{C=C}}$.²⁷³ However, bands in this region of the spectrum of the complex can be attributed to the phenyl nuclei, and unambiguous assignments are not possible.

Several transition metal (non-carbonyl) complexes of aziridine and substituted aziridines have been reported²⁷⁵⁻⁸ and they all show a strong infrared absorption in the region 850-900 cm^{-1} , due to the ring deformation. There is no band in this region in the spectrum of $\text{Mn}(\text{CO})_4(\text{Ph}_2\text{CNCPh}_2)$, and, since the band position is little affected by substituents in the ring or by co-ordination to the metal²⁷⁵, a structure of type (d) can probably be ruled out.

Thus, of the structural types indicated in Fig.III.8, (c), (d) and (e) can perhaps be ruled out. It is perhaps most likely that the structure of the complex is intermediate between types (a), (b) and (f), with the N atom of the ligand sp^{1-2} hybridised, and the metal interacting with both the nitrogen lone pair, and the π -orbitals of the CNC skeleton.

When the reaction between $(\pi\text{-Cp})_2\text{Ni}$ and $\text{Ph}_2\text{C=N-C(Cl)Ph}_2$ was allowed to continue for 4 days, a small amount of pale brown solid was isolated and identified as tetraphenylethylene by analytical and infrared spectroscopic

techniques. The compound is white when pure, but is often obtained initially as a pale yellow solid.^{279,280} Its slightly low melting point indicates the presence of some impurity.

When the reaction was interrupted after 14 hrs., some unreacted nickelocene was recovered and a complex isolated, for which analytical data, together with theoretical values for some nickel complexes, is shown in Table III.2. Since nickel and chlorine were detected in the residue in each reaction, and the infrared spectrum showed only weak absorptions, it seems that the ultimate products of the reaction between $(\pi\text{-Cp})_2\text{Ni}$ and $\text{Ph}_2\text{C}=\text{N}-\text{C}(\text{Cl})\text{Ph}_2$ are $\text{Ph}_2\text{C}=\text{CPh}_2$ and NiCl_2 . However, a complex series of reactions must occur in which the cyclopentadienyl groups are displaced from the metal by the ligand, or some derivative of the ligand, and the resulting complex eliminates $\text{Ph}_2\text{C}=\text{CPh}_2$. The ligand itself could become attached to the metal, or it could ionise first, and the cation, $\text{Ph}_2\text{C}=\text{N}-\overset{+}{\text{C}}\text{Ph}_2$ become attached to the metal. However, the former possibility is perhaps the most likely and a reaction path something like the one shown in the equation can be envisaged:

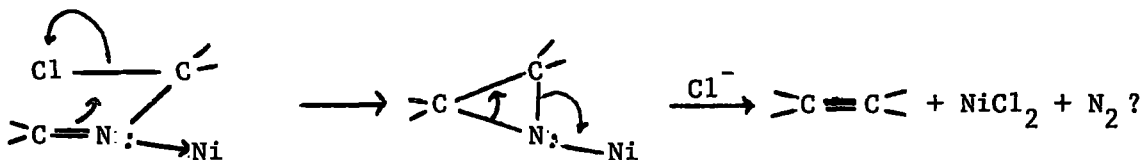

Co-ordination of the ligand via the nitrogen lone pair would withdraw charge from the adjacent carbon atoms and weaken the C-Cl bond. Rupture of this bond would be encouraged by the polar solvent CHCl_3 ; lack of reaction in toluene may be due to the non-polar nature of this solvent.

Table III.2.

	%C	%H	%N	%halogen
For Ni complex isolated	76.3, 78.6	4.9	1.8	<1%
$(\text{Ph}_2\text{CNCPh}_2)_2\text{Ni}$ requires	83.1	5.3	3.7	-
$(\text{Ph}_2\text{CNCPh}_2)\text{Ni}(\text{Ph}_2\text{C=CPh}_2)$ requires	84.6	5.4	1.9	-
$[(\text{Ph}_2\text{CNCPh}_2)\text{NiCl}]_2$ requires	71.1	4.5	3.2	8.0

On warming a toluene solution of $\text{Ni}(\text{CO})_4$ and $\text{Ph}_2\text{C=N-C}(\text{Cl})\text{Ph}_2$ to $\sim 40^\circ\text{C}$, rapid decomposition of the carbonyl was observed and a deep red colour was observed. Since $\text{Ni}(\text{CO})_4$ itself does not decompose quite so rapidly (in the vapour state decomposition is slow at 100°C), it is possible that interaction between the ligand and $\text{Ni}(\text{CO})_4$ was catalysing the decomposition. This is supported by the fact that the $\text{Ph}_2\text{C=NC}(\text{Cl})\text{Ph}_2$ recovered from the reaction mixture contained considerable quantities of $\text{Ph}_2\text{C=CPh}_2$, as shown by infrared spectroscopy - the spectrum of the yellow crystals obtained from the reaction is identical to that obtained by superimposing the spectra of $\text{Ph}_2\text{C=N-C}(\text{Cl})\text{Ph}_2$ and $\text{Ph}_2\text{C=CPh}_2$.

Thus, it seems probable that similar reactions occur between $\text{Ph}_2\text{C=NC}(\text{Cl})\text{Ph}_2$ and $\text{Ni}(\text{CO})_4$ and $(\pi\text{-Cp})_2\text{Ni}$, $\text{Ph}_2\text{C=CPh}_2$ being the final product in each case. In the case of the carbonyl though, the reaction was much more rapid and it seems that total decomposition of $\text{Ni}(\text{CO})_4$ occurred before all the ligand had reacted.

CHAPTER FOUR

Reactions of the Grignard Derivative of Diphenylketimino
diphenylmethylchloride with Transition Metal Complexes

A. Experimental

1. Preparation of the Grignard of $\text{Ph}_2\text{C}=\text{NC}(\text{Cl})\text{Ph}_2$

Diphenylketiminodiphenylmethyl chloride was dissolved in THF to give a yellow solution, and a slight excess of magnesium turnings was added. No reaction occurred until a few drops of dibromoethane had been added, and sometimes warming was also necessary to initiate the reaction. A darkening in colour was usually observed, and on occasions the colour became very dark purple, but when almost all the magnesium had dissolved, the solution had become very pale yellow. The time taken to reach this stage varied from one to three hours. The solution was filtered from the undissolved magnesium before use. THF was used as the solvent since $\text{Ph}_2\text{C}=\text{NC}(\text{Cl})\text{Ph}_2$ is only slightly soluble in ether.

2. $\text{Mn}(\text{CO})_5\text{Br} + (\text{Ph}_2\text{CNCPh}_2)\text{MgCl}$

A solution of $(\text{Ph}_2\text{CNCPh}_2)\text{MgCl}$ was filtered into a solution of manganese pentacarbonyl bromide (1.1 g., 4 mmoles) in THF (20 ml.). No reaction occurred at room temperature over 16 hrs., but after heating at 80°C overnight, a slight amount of white precipitate had separated from the darkened yellow solution. After removal of solvent under vacuum a red oil remained which did not yield a solid after washing with pentane and toluene. The oil was extracted with several portions of ether until the extracts were colourless, leaving a white solid. The combined extracts again gave a red oil on removal of solvent but yellow-orange needle-like crystals were eventually

obtained by extracting with a CHCl_3 /hexane mixture, and cooling to -20°C . Careful adjustment of the volumes of each solvent was necessary, otherwise an oil separated out. Warming a CHCl_3 solution of the compound produced a white precipitate which would not redissolve in chloroform. The compound is formulated as $\text{BrMn}(\text{CO})_4(\text{Ph}_2\overset{\text{H}}{\text{CNCPh}}_2)$, on the basis of analytical and spectral evidence. M.Pt. $133-5^\circ\text{C}$ (d). Found: C, 60.6; H, 3.5; N, 2.8; Br, 14.6%. $\text{Mn}_{30}\text{H}_{21}\text{NOBr}$ requires C, 60.6; H, 3.5; N, 2.4; Br, 13.5%.

In an attempt to eliminate HBr from the complex, an ether solution was irradiated for ~ 30 mins. Rapid decomposition to a white, non-carbonyl residue occurred and no intermediate carbonyl complex could be detected.

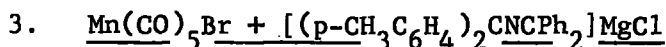

The method used to prepare the Grignard derivative of $(\text{p-CH}_3\text{C}_6\text{H}_4)_2\text{CNCPh}_2$ ²⁶⁸ was identical to that described previously for the diphenyl derivative. Equimolar quantities of the Grignard and $\text{Mn}(\text{CO})_5\text{Br}$ in THF were allowed to react at 75°C overnight, when a dark yellow solution and a little white precipitate were observed. Removal of solvent under vacuum and extraction of the brown oil remaining with chloroform gave a yellow solution, whose infrared spectrum was very similar to that of $\text{BrMn}(\text{CO})_4(\text{Ph}_2\overset{\text{H}}{\text{CNCPh}}_2)$, with carbonyl absorptions at 2105(w), 2031(sh), 2025(s), 1938(s,br) cm^{-1} . Repeated attempts to obtain crystals from CHCl_3 /hexane and from THF/hexane solutions yielded only brown oils. On one occasion, a small amount of yellow solid was obtained which was thermally unstable, even in the solid state (on heating in a tube sealed under nitrogen, the solid darkened $\sim 50^\circ\text{C}$

and melted with decomposition $\sim 75^{\circ}\text{C}$) and inconsistent analytical data was obtained.

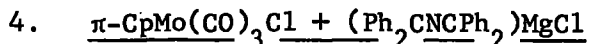

A THF solution of the Grignard reagent (2 mmolar) was filtered into a red solution of π -cyclopentadienylmolybdenumtricarbonyl chloride (0.27 g., 2 mmoles) in THF (20 ml.) and the reaction followed by infrared spectroscopy. After overnight stirring at room temperature, much starting material remained, but a new weak band at 1880 cm^{-1} was detected. A portion of this solution was heated for several hours at 70°C , but the spectrum was little changed, and removal of solvent left an oil, which could not be crystallised. The other portion of the solution was irradiated for several hours. Again, the carbonyl absorptions due to starting material, and the band at 1880 cm^{-1} persisted, but the tar obtained on removal of solvent could not be crystallised.

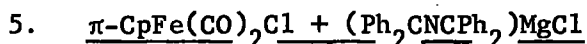

A THF solution of the Grignard (2 mmolar) was filtered into a red solution of π -cyclopentadienylirondicarbonyl chloride (0.44 g., 2 mmoles) in THF (20 ml.). After stirring overnight, no change was observed, but removal of solvent and extraction of the oily residue with CHCl_3 gave a red solution whose infrared spectrum showed two strong carbonyl absorptions, very slightly shifted from those of $\pi\text{-CpFe(CO)}_2\text{Cl}$. Suspecting that the σ -allyl type of complex had formed, after removal of solvent, the residue was sublimed. Only $\pi\text{-CpFe(CO)}_2\text{Cl}$ collected on the cold finger (identified by its infrared

spectrum) and an i.r. spectrum of the residue showed no carbonyl absorptions.

The reaction was repeated and the THF solution refluxed. No new carbonyl absorptions could be detected in the infrared spectra of the solution and after 6 hrs., bands due to $\pi\text{-CpFe(CO)}_2\text{Cl}$ had disappeared. A small amount of non-carbonyl precipitate was obtained, and the solution yielded an orange tar, which, though soluble in several solvents, could not be induced to crystallise. In another reaction, the THF was removed after overnight stirring, and an ether extract was irradiated. No new carbonyl species could be detected before decomposition had occurred.

6. $\text{NiCl}_2 \cdot 2\text{THF} + (\text{Ph}_2\text{CNCPh}_2)\text{MgCl}$

Reaction between equimolar quantities of the nickel dichloride/THF adduct (described in Chapter II) and the Grignard reagent was attempted several times using a similar reaction procedure. When the pale yellow THF solution of the Grignard was filtered into the THF suspension of $\text{NiCl}_2 \cdot 2\text{THF}$ an immediate bright green colour was observed. On stirring at room temperature, sometimes the colour persisted and eventually the $\text{NiCl}_2 \cdot 2\text{THF}$ dissolved completely. On other occasions, a deep yellow colour developed and a precipitate formed. One one occasion, an orange solid was isolated, and on other occasions, pale green solids were obtained, by continuous liquid extraction with benzene of the solid remaining after removal of THF. All these solids were shown to contain nickel, and analytical data indicated the presence of C, H, N and chlorine, but the figures obtained were inconsistent. The infrared spectra of different samples varied, but all showed bands

attributable to the organo groups. The compounds were all extremely air sensitive. Reaction to produce a nickel complex containing the organic ligand in some form is apparently occurring, but reproducible results could not be obtained.

B. Results and Discussion

Warming a THF solution of $\text{Mn}(\text{CO})_5\text{Br}$ and $(\text{Ph}_2\text{CNCPh}_2)\text{Mg}$ caused reaction to occur with formation of the complex $\text{BrMn}(\text{CO})_4(\text{Ph}_2\overset{\text{H}}{\text{CNCPh}}_2)$. The analogous compound $\text{BrMn}(\text{CO})_4[(p\text{-CH}_3\text{C}_6\text{H}_4)_2\overset{\text{H}}{\text{CNCPh}}_2]$ was detected spectroscopically, but only obtained as an oil. Reaction occurred between the Grignard derivative and $\text{NiCl}_2 \cdot 2\text{THF}$, but reproducible results in the reaction could not be achieved. Attempts to initiate reaction between $(\text{Ph}_2\text{CNCPh}_2)\text{MgCl}$ and $\pi\text{-CpMo}(\text{CO})_3\text{Cl}$ and $\pi\text{-CpFe}(\text{CO})_2\text{Cl}$, both thermally and photochemically, were unsuccessful. In the molybdenum case, indication that some slight reaction was occurring was obtained, but attempts to isolate a solid yielded only a tar. In the iron system, the formation of a new complex, possibly a σ -type derivative was suspected, but when the reaction was worked up, only starting materials were recovered. Heating and irradiation of the solution both produced a tar, which could not be crystallised.

The complex $\text{BrMn}(\text{CO})_4(\text{Ph}_2\overset{\text{H}}{\text{CNCPh}}_2)$ was obtained as yellow, needle-like crystals. In the solid state, slight decomposition occurs on storing under N_2 for several weeks, but decomposition in solution is much more rapid, especially on warming. It is very soluble in chloroform, and THF, fairly soluble in ether, slightly soluble in toluene and benzene, and almost insoluble in pentane.

In an attempted sublimation of the complex, at 100-120°C, an orange oil appeared on the cold finger, which was soluble in CHCl_3 but a solution spectrum showed no carbonyl absorptions. The pale yellow residue was almost insoluble in CHCl_3 , and its infrared spectrum showed no carbonyl bands, and the other absorptions, mainly in the region where phenyl groups absorb, were weak.

The bands observed in the infrared spectrum (Nujol mull) of the complex are listed in Table IV.1, together with those of $\text{Ph}_2\text{C}=\text{NC}(\text{Cl})\text{Ph}_2$ for comparison. A weak absorption at 3226 cm^{-1} is assigned to a N-H stretching frequency, and confirms the presence of hydrogen on the nitrogen. An absorption at 1618 cm^{-1} is assigned to a C=N stretching frequency (cf. $\nu_{\text{C}=\text{N}}$ in $\text{Ph}_2\text{C}=\text{N}-\text{C}(\text{Cl})\text{Ph}_2$ at 1623 cm^{-1}). The remainder of the spectrum shows considerable changes in the positions and numbers of absorptions, compared to the spectrum of the starting material.

A high resolution spectrum of the complex in CHCl_3 shows carbonyl absorptions at $2104(\text{w})$, $2035(\text{s})$, $2020(\text{sh})$, $1955(\text{s})$, $1923(\text{s})\text{ cm}^{-1}$. Group theoretical treatments of $\text{Mn}(\text{CO})_4\text{LX}$ octahedral molecules indicate that a cis-tetracarbonyl complex should have 4 active CO stretching modes in the infrared spectrum (3 strong and 1 weak) while the trans isomer should give rise to only 2 absorptions (1 weak and 1 strong).^{281,282} The cis- and trans-tricarbonyl compounds $\text{Mn}(\text{CO})_3\text{L}_2\text{X}$ should give rise to 3 strong absorptions, and 1 weak and 2 strong absorptions, respectively.²⁸³ Thus the solution spectrum of $\text{BrMn}(\text{CO})_4(\text{Ph}_2\text{CNCPh}_2)$ is consistent with the compound being a tetracarbonyl

Table IV.1.

Infrared Spectra (Nujol mull) of $\text{BrMn}(\text{CO})_4(\text{Ph}_2\overset{\text{H}}{\text{C}}\text{NCPH}_2)$ and $\text{Ph}_2\text{C}=\text{NC}(\text{Cl})\text{Ph}_2$

$\text{BrMn}(\text{CO})_4(\text{Ph}_2\overset{\text{H}}{\text{C}}\text{NCPH}_2)$ cm ⁻¹	$\text{Ph}_2\text{C}=\text{NC}(\text{Cl})\text{Ph}_2$ cm ⁻¹	Assignment ^{268,273}
3226(w) 2032(s) 2022(s) 1942(s, sh) 1923(s)		N-H
1618(m) 1600(m) 1580(m) 1486(sh) 1453(sh)	1623(m) 1597(m) 1575(m) 1490(sh) 1449(sh)	C=N C=N ? C=C (of aromatic C=C nuclei) } Phenyl nuclei
1241(m)	1314(w) 1280(m) 1269(m, sh)	
1164(m)	1193 } 1183 } (m) 1175 } 1160 } 1151 } 1085 } (w) 1075 }	
1080(m) 1031(w)	1031 } (m) 1022 }	} In Plane Bending of Phenyl Groups
1004(m)	1008 } 1002 } (w) 995 }	
973(vw) 935(m) 908(m) 780 } 772 } (s, split)	973(m) 894(w) 845(vw) 787(m) 769(s) 751(sh) 745(s)	} Out of Plane Bending
747(w) 730(s) 701(vs) 694(sh)	730 } 724 } (s, split) 696(vs) 667(m)	} C-Cl } Out of Plane Bending
649(s) 627(vs) 614(w) 595(s) 570(vw) 527(s) 495(w, br)	637(w) 628(w) 616(w) 600(s) 589(w)	} MCO bend

derivative with the bromide ion and ligand in mutually cis positions. The pattern of carbonyl absorptions in the solid state differs slightly from that in the solution; the weak high frequency band has disappeared, and the shoulder at 2020 cm^{-1} is more resolved. These differences could be due to crystal packing effects in the solid, or might suggest a slight change in symmetry in the solid state.²⁸²

In the far-infrared spectrum of the complex, a broad absorption, centred at 214 cm^{-1} is observed. A similar band is centred at 216 cm^{-1} (lit. 218 cm^{-1})²⁸⁴ in the spectrum of $\text{Mn}(\text{CO})_5\text{Br}$ and is assigned to the Mn-Br stretching frequency.²⁸⁴

There appear to be no other reported tetracarbonyl manganese halide complexes containing nitrogen ligands. (Table I.2(ii), p. 40). Reaction of $\text{Mn}(\text{CO})_5\text{X}$ (X = Cl, Br, I) with amines e.g. py, aniline, gives the di-substituted derivative $\text{Mn}(\text{CO})_3\text{L}_2\text{X}$ directly, with no evidence for formation of $\text{Mn}(\text{CO})_4\text{LX}$ species.¹⁴ It is possible that the bulky ligand in the complex $\text{BrMn}(\text{CO})_4(\text{Ph}_2\overset{\text{H}}{\text{C}}\text{NCPH}_2)$ makes the metal sterically crowded, so that the mono-substituted complex is more stable than the disubstituted one would be. Tetracarbonyl derivatives containing other ligands have been prepared²⁸¹, e.g. $\text{Mn}(\text{CO})_4(\text{PPh}_3)\text{Br}$.

A p.m.r. spectrum of $\text{BrMn}(\text{CO})_4(\text{Ph}_2\overset{\text{H}}{\text{C}}\text{NCPH}_2)$ in CDCl_3 (with TMS as internal reference) was obtained after 339 accumulations using a Digico C.A.T. The spectrum shows a strong peak at 2.76τ , with a little fine structure discernible due to the protons in the phenyl groups, and a weak peak at 0.04τ

due to the hydrogen on the nitrogen. The approximate ratio of peak areas is 20:1, as required by the complex.

Repeated attempts were made to obtain a mass spectrum of the complex, via the direct insertion probe. The source temperature at insertion was varied from room temperature to 150°C, and the accelerating voltage was varied from 8 eV to 70 eV. In each case, the only peaks observed were due to breakdown of the organic ligand, and no metal-containing fragments could be detected. As in the case of the complex $\text{Mn}(\text{CO})_4(\text{Ph}_2\text{CNCPh}_2)$, the highest intense peak was observed at m/e 182, which corresponds to $[\text{Ph}_2\text{CNH}_2]^+$, apart from a peak at m/e 332, corresponding to $[\text{Ph}_2\text{CCPh}_2]^+$, which may arise from thermal decomposition of the complex, or be present as an impurity. No peak was observed at m/e 342, corresponding to $[\text{Ph}_2\text{CNCPh}_2]^+$.

Molecular weight determinations could not be made on the complex, as it is too unstable in solution for ebullioscopic or osmometric measurements to be made, and not soluble enough in suitable solvents for cryoscopic measurements.

The Mn-Br stretching frequency in the far-infrared spectrum confirms that the bromine is attached to the metal rather than the organic ligand, and rules out the possibility that the complex is of the type $[\text{Mn}(\text{CO})_4\text{Ph}_2\overset{\text{H}}{\text{C}}-\overset{\text{H}}{\text{N}}-\text{CPh}_2]^+\text{Br}^-$, in which the positively charged ligand would be isoelectronic with $[\text{R}_2\overset{\text{H}}{\text{C}}-\overset{\text{H}}{\text{C}}-\text{CR}_2]$. It seems likely, then, that the ligand in the complex is neutral, donating 2 electrons to the metal. The source of the hydrogen on the nitrogen is thought to be the solvent.

As for $\text{Mn}(\text{CO})_4(\text{Ph}_2\text{CNCPh}_2)$, several types of metal ligand bonding can be envisaged for $\text{BrMn}(\text{CO})_4(\text{Ph}_2\text{CNCPh}_2)$ and some of them are represented schematically in Fig.IV.1.

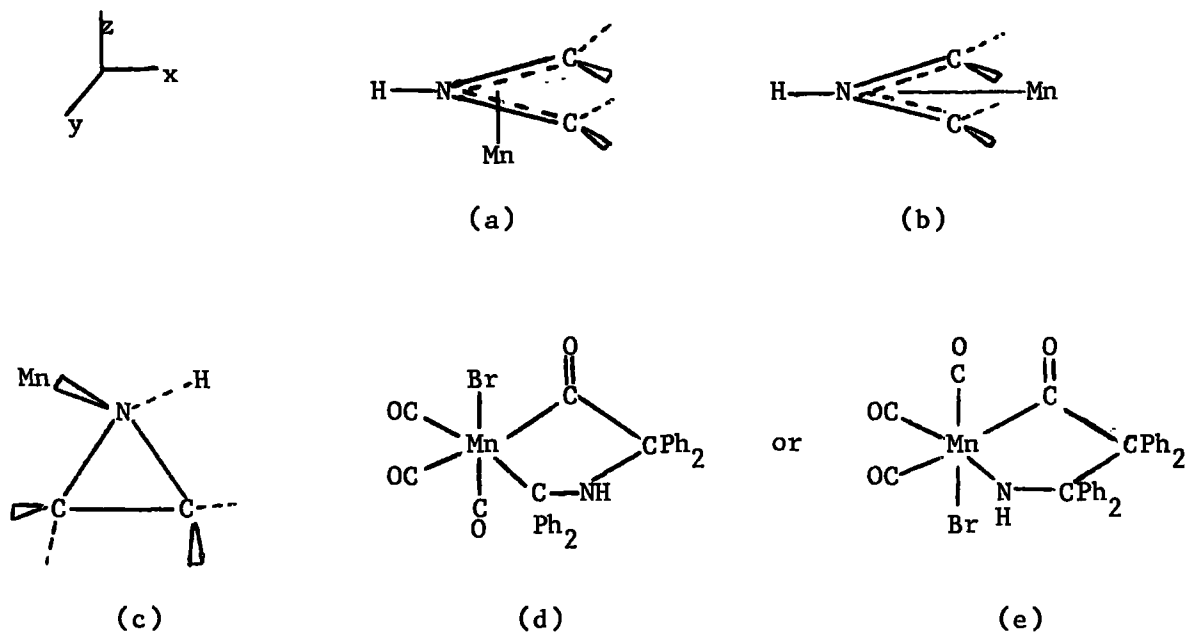
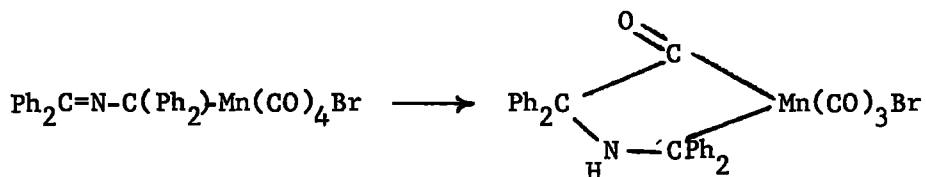

Fig.IV.1.

The first possibility, (a) represents a pseudo-allylic type of bonding scheme. The N atom is sp^2 hybridised, as are the two C atoms, and these orbitals form σ -bonds. The p_z orbitals on each atom (with reference to the axes drawn) can overlap to form π -bonds, but in this case, the p_z orbital on the nitrogen is occupied by 2 electrons and so there are 4 electrons to occupy the π -orbitals of the CNC skeleton, whereas in the neutral ligand ($\text{Ph}_2\text{CNCPh}_2$), only 3 electrons occupy the CNC π -orbitals. Some overlap between

metal orbitals and the π -orbitals could occur to give metal-ligand bonding. Structure (c) represents the possibility of bond formation between the two carbon atoms to give a substituted aziridine ring. This would perhaps not be unreasonable, since Acheson²⁸⁵ describes the synthesis of aziridines from alkyl or aryl magnesium halides and ketimine derivatives. Metal-ligand bonding in (c) is via the nitrogen lone pair.

Structures (d) and (e) are similar to the cyclic acyl structures proposed by King and Bisnette¹⁰⁵ for the compounds $(\text{CH}_3)_2\text{NCH}_2\text{CH}_2\text{COMn}(\text{CO})_4$ and $\text{NC}_5\text{H}_4\text{CH}_2\text{COMn}(\text{CO})_4$. They suggest that initially the σ -complex forms e.g. $(\text{CH}_3)_2\text{NCH}_2\text{CH}_2\text{Mn}(\text{CO})_5$ (from $\text{NaMn}(\text{CO})_5$ and $\text{ClCH}_2\text{CH}_2\text{N}(\text{CH}_3)_2$) which can then undergo an intramolecular rearrangement to form the cyclic acyl derivative. A similar pathway can be imagined for the complex $\text{BrMn}(\text{CO})_4(\text{Ph}_2\overset{\text{H}}{\text{CNCPh}}_2)$ i.e.



Rearrangement of the skeleton would be required to give structure (e).

Structure (b) can probably be ruled out on steric grounds, when a model of the ligand is studied. Structures (a) and (c) are both possible, but as for the complex $\text{Mn}(\text{CO})_4(\text{Ph}_2\overset{\text{H}}{\text{CNCPh}}_2)$, no absorption in the 850-900 region, due to ring deformation²⁶², is observed in the infrared spectrum of $\text{BrMn}(\text{CO})_4(\text{Ph}_2\overset{\text{H}}{\text{CNCPh}}_2)$. The band at 1618 cm^{-1} in the spectrum of the complex has been assigned to a C=N stretching frequency. This is not inconsistent with the bonding description given for structure (a), since there are 4

electrons in the π -orbitals of the CNC skeleton and it is possible that the CN bond order will approach 2.

The two acyl structures (d) and (e) could also perhaps account for the band at 1618 cm^{-1} , since the acyl carbonyl stretching frequencies in the compounds $(\text{CH}_3)_2\text{N}(\text{CH}_2)_2\text{COMn}(\text{CO})_4$ and $\text{NC}_5\text{H}_4\text{CH}_2\text{COMn}(\text{CO})_4$ occur at 1660 and 1668 cm^{-1} , respectively.¹⁰⁵ However, the pattern of carbonyl absorptions in the spectrum of the complex differs from that expected for a cis-tricarbonyl manganese complex. Also, the 4 phenyl groups in these two structural types would not be equivalent, and the p.m.r. spectrum of $\text{BrMn}(\text{CO})_4(\text{Ph}_2\overset{\text{H}}{\text{CNCPh}}_2)$ shows that they are.

Thus, structures of type (a) or (c) seem the most likely for the complex $\text{BrMn}(\text{CO})_4(\text{Ph}_2\overset{\text{H}}{\text{CNCPh}}_2)$, with structure (a) perhaps the most likely possibility.

In order to understand more fully the type of bonding between the metal and ligand in the complex $\text{BrMn}(\text{CO})_4(\text{Ph}_2\overset{\text{H}}{\text{CNCPh}}_2)$, the preparation of the ligand $\text{Ph}_2\text{C}=\text{N}-\text{C}(\text{H})(\text{CH}_3)_2$ was attempted, in the hope that the analogous compound $\text{BrMn}(\text{CO})_4(\text{Ph}_2\overset{\text{H}}{\text{CNC}}(\text{CH}_3)_2)$ could be prepared via the lithium derivative of the ligand. The simplified spectra of this complex may have been more readily interpreted. However, the reaction of $\text{Ph}_2\text{C}=\text{NLi}$ with $(\text{CH}_3)_2\text{CCl}$, in refluxing toluene, gave a precipitate of LiCl but no trace of the required compound.

Ideally, studies of the reactions of the ligand $\text{R}_2\text{C}=\text{N}-\text{C}(\text{Cl})\text{R}_2$, where R is H, or a simple alkyl group with $\text{Mn}(\text{CO})_5\text{Br}$ would have given spectral data

which could probably be easily interpreted. However, the route to this ligand involves the use of ketiminolithium compounds, and only diarylketimines were available at the time ($(t\text{-Bu})_2\text{C}=\text{NH}$) has very recently been prepared in these laboratories²⁸⁶).

C. Conclusions

Studies of the ligand $\text{Ph}_2\text{C}=\text{N}-\text{C}(\text{Cl})\text{Ph}_2$ and its Grignard derivative, with transition metal carbonyl and non-carbonyl compounds have yielded some interesting results. Two manganese carbonyl complexes could be isolated and characterised, although both appeared to decompose readily, especially in solution. It is tentatively proposed that these complexes both contain a pseudo-allylic or related type of structure. The information obtained on the nickel systems studied showed that complex formation between the metal and some form of the ligand occurred, but that the resulting species were extremely unstable and rapidly decomposed. In one case, tetraphenylethylene was identified as one of the decomposition products.

Attempted reactions between the ligand and π -cyclopentadienyl molybdenum and iron carbonyl halides were unsuccessful. A possible explanation for the lack of reaction between these compounds, (and between $\text{Na}\pi\text{-CpMo}(\text{CO})_3$ and $\text{Ph}_2\text{C}=\text{N}-\text{C}(\text{Cl})\text{Ph}_2$) is that the sterically crowded ligand prevents the metal, with its bulky substituents, from approaching near enough for bond formation to occur. The existence of the stable complexes $\pi\text{-CpM}(\text{CO})_2(\text{Ph}_2\text{CNCPh}_2)$ ($\text{M} = \text{Mo}^{130}, \text{W}^{261}$) in which the ligand is thought to be

pseudo allylic¹³⁰ seems to contradict this idea. However, the ligand in these derivatives was synthesised "in situ" from 2 moles of $\text{Ph}_2\text{C}=\text{NLi}$ and its geometrical arrangement in the complex perhaps differs from that in the ligand, allowing metal-ligand bonding to occur.

CHAPTER FIVE

Some Aziridine Derivatives of Transition Metal Carbonyls

A. Introduction

Since one of the possible structures of both the complexes $\text{Mn}(\text{CO})_4(\text{Ph}_2\text{CNCPh}_2)$ and $\text{BrMn}(\text{CO})_4(\text{Ph}_2\overset{\text{H}}{\text{CNCPh}}_2)$ involves an aziridine ring, some preliminary studies of aziridine ligands in metal carbonyl systems were undertaken. The aims of the study were, firstly, to see if aziridine would form complexes with metal carbonyls containing the three-membered ring, and secondly, to see if ring opening would lead to pseudo-allyl type complexes. The use of tetraphenylaziridine may have given compounds similar to those obtained from $\text{Mn}(\text{CO})_5\text{Br}$ and $\text{Ph}_2\text{C}=\text{NC}(\text{Cl})\text{Ph}_2$, but this aziridine has been only tentatively reported as an impurity²⁸⁷ and so the unsubstituted aziridine, ethyleneimine, was studied initially.

Ethyleneimine has been reported to form quite stable complexes with several transition metals²⁷⁵⁻²⁷⁸, e.g. $[\text{Co}^{\text{III}}\text{Az}_4(\text{NO}_2)_2]\text{Br}$ ²⁷⁵, $[\text{Cr}^{\text{III}}\text{Az}_5\text{H}_2\text{O}]\text{Cl}_3$ ²⁷⁵ and $[\text{Mn}^{\text{II}}\text{Az}_4]\text{Cl}_2$ ²⁷⁶. The complexes are similar to those formed by NH_3 and primary amines^{275,276}, and the steric properties of ethyleneimine fall between those of MeNH_2 and EtNH_2 ²⁷⁶. The ligand seems to complex more strongly than expected for a secondary amine of comparable basicity, and the ring is quite stable when bonded to a metal in a solid complex.²⁷⁶ However, many unsuccessful attempts have been made to synthesise complexes with aziridine, which are well known with other amines and with pyridine.²⁷⁵ Spectroscopy showed that ring cleavage had occurred in these reactions.

Ring opening of aziridines is catalysed by acids, which protonate the

nitrogen to give the immonium ion, and subsequent attack by a nucleophile with simultaneous ring opening occurs.²⁸⁸ e.g.

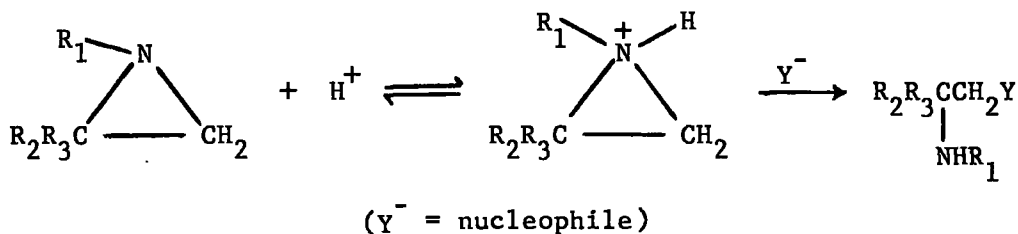

If the nucleophile is an uncharged aziridine molecule, then polymerisation will occur:²⁸⁵

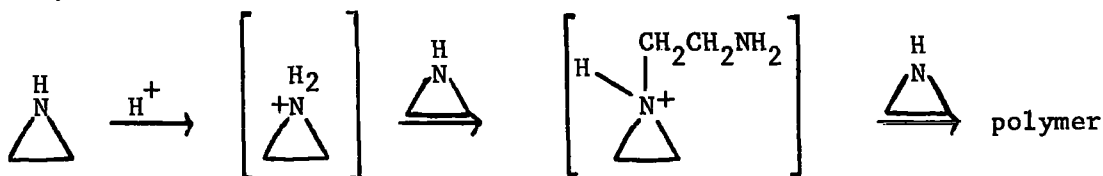

Branching of the polymer can occur, the degree of branching depending upon the concentration of the catalyst (i.e. the acid) and on the temperature.²⁸⁹

Although rupture of a C-N bond usually occurs in ring opening, pyrolytic isomerisation by rupture of the C-C bond has been reported²⁹⁰, e.g.

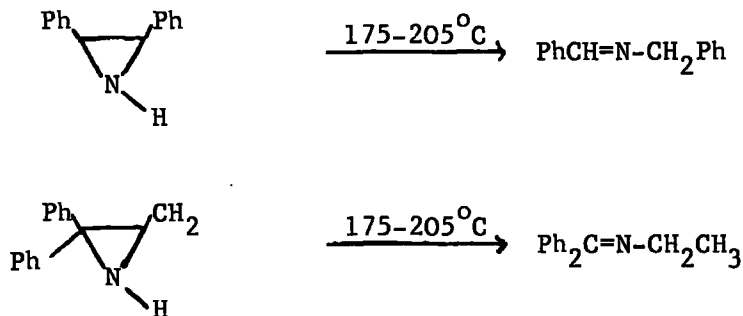

Derivatives and polymers of aziridines have wide industrial and pharmaceutical applications, and in particular, some of the transition metal complexes are potential agents in cancer chemotherapy.²⁷⁵

Studies of ethyleneimine with $\text{Mn}(\text{CO})_5\text{Br}$ and the Group VI metal carbonyls were undertaken, since, besides the possible relevance of the manganese system to the work described in the two previous chapters, these carbonyls all form stable derivatives with a variety of amines (see Chapter I).

B. Experimental

1. $\text{Mn}(\text{CO})_5\text{Br}$ + Aziridine

This reaction was repeated several times, and was monitored by infrared spectroscopy.

(a) Ethyleneimine (0.2 ml., 4 mmoles) in chloroform (2 ml.) was added to a solution of manganese pentacarbonyl bromide (1.1 g., 4 mmoles) in chloroform (40 ml.). Effervescence occurred slowly but after 24 hrs. at room temperature, an additional amount of ethyleneimine (0.2 ml., 4 mmoles) was required to complete the reaction. The yellow solid obtained on removal of volatiles was recrystallised from CHCl_3 /hexane to give yellow crystals of complex I (yield, 1g.). Sublimation at $60-80^\circ\text{C}$, 0.001 mms/hg gave a very small amount of sublimate. The bulk of the solid did not sublime and after recrystallisation, was shown to be I. M.Pt. $110-112^\circ\text{C}$.

The infrared spectrum of I in CHCl_3 , before sublimation showed bands at 2105(vw), 2037(s), 2019(w,sh), 1976(vw) and 1931(s,br) cm^{-1} . After sublimation, the recrystallised residue showed carbonyl absorptions at 2037(s), 1932(s),

1916(s,sh) cm^{-1} . The small amount of sublimate dissolved in CHCl_3 , but the solution was too weak to give a spectrum.

Analytical data for Complex I. Found, (before sublimation): C,39.9, 37.8; H,4.0; N,11.6, 10.6; Br, 20.2%; (residue, after sublimation):C,31.9, 30.7; H,2.6; N,6.9; Br, 25.7%. $\text{Mn}(\text{CO})_3(\text{C}_2\text{H}_5\text{N})_2\text{Br}$ requires C,28.8; H,3.3; N,9.2; Br,26.2%.

(b) On repetition of the reaction, using a 2:1 molar ratio of $\text{C}_2\text{H}_5\text{N}:\text{Mn}(\text{CO})_5\text{Br}$, reaction was complete after 26 hrs. The solution spectrum was similar to that observed for I (before sublimation) but the previously weak bands at 2105, 2019 and 1976 cm^{-1} were of greater intensity. Sublimation at 60°C, 0.001 mm/hg gave a yellow sublimate, II, whose solution spectrum showed absorptions at 2100(m), 2020(vs), 1970(s) cm^{-1} . Thus the weaker bands in the spectrum of I are probably due to II.

Analytical data for complex II: C,51.8; H,5.0; Br,26.1%.

(c) Manganese pentacarbonyl bromide (0.3 g., 1.1 mmoles) was treated with ethyleneimine (1 ml., excess), and immediate vigorous effervescence was observed, with dissolution of the solid to give a clear dark orange solution. Effervescence ceased after ~5 mins. and after stirring for 30 mins., hexane (10 ml.) was added. A tarry, yellow solid slowly separated which, after washing with hexane, was recrystallised from CHCl_3 /ether (Yield, 0.18 g.). The solution spectrum of the crude product was almost identical to that of I (before sublimation) but after recrystallisation, only absorptions at 2037(s) and 1927(s,br) cm^{-1} were observed, and the main product of the

reaction was identified as I. However, sublimation of this sample (at 60°C, 0.001 mms/Hg) gave a little sublimate, III, with carbonyl absorptions at 2037(s), 1946 and 1914 (s,split) cm^{-1} . The spectrum of the recrystallised residue I, was unchanged. Analytical data for complex I.

Found (before sublimation): C, 35.5, 32.9, 36.0; H, 4.6, 4.7; N, 10.9; Br, 43.3, 25.6%. Residue after sublimation: C, 30.5; H, 4.4%.

(d) Manganese pentacarbonyl bromide (0.83 g., 3 mmoles) was cooled to -196°C and treated with ethyleneimine (2 ml.). On warming to room temperature, the solid dissolved to give a yellow solution; vigorous gas evolution occurred and the reaction vessel became quite hot. The dark orange gum obtained was stirred with ether for 2 days, when a pale yellow powder was obtained, which was washed with ether and pumped dry (Yield, 2.5 g.). This compound, IV, was insoluble in all common organic solvents and could not be recrystallised. Analytical data for complex IV.

Found: C, 32.5, 34.3, 33.0; H, 5.1, 5.4, 6.0; N, 8.1; Br, 43.7, 42.1%.

2. Mn(CO)₅Br + lithiumaziridine

(a) A suspension of lithiumaziridine was prepared as follows. Ethyleneimine (0.16 ml., 3 mmoles) in monoglyme (10 ml.) was cooled to -196°C and treated with n-butyllithium in hexane (3 mmoles). (MeLi can also be used).⁸ On warming to room temperature a white suspension of the lithium salt was observed, and after 1 hr., this was treated with a solution of manganese pentacarbonyl bromide (0.75 g., 3 mmoles) in monoglyme (40 ml.). Effervescence occurred and after several hours, the quantity of white

precipitate had increased. A solution infrared spectrum of the reaction medium showed several absorptions in the carbonyl region, suggesting a mixture of products but attempts to obtain a solid gave only a tar, and attempted separation of the mixture by chromatography was unsuccessful.

(b) In a repeat of the reaction, after filtration from the white precipitate, the solution was refluxed for several hours, when some of the carbonyl absorptions in the solution infrared spectrum disappeared. Filtration, concentration of the solution, addition of ether and cooling to -20°C gave yellow crystals which were kept cold during isolation, but on finally pumping dry, they changed to an oil. All further attempts to obtain a solid were unsuccessful. An infrared spectrum of the oil showed the presence of coordinated ethyleneimine, but also bands due to monoglyme.

No reaction could be detected between the oil, and triphenylphosphine, in monoglyme.

3. Group VI metal carbonyls + Aziridine

(a) $\text{Cr}(\text{CO})_6$ + Aziridine

No reaction occurred between chromium hexacarbonyl and ethyleneimine in refluxing hexane.

Chromium hexacarbonyl (0.23 g., 1 mmole) was placed in a thick-walled glass tube and cooled to -196°C . After addition of aziridine (1 ml., excess), the tube was evacuated, sealed, and allowed to warm up to room temperature. Some $\text{Cr}(\text{CO})_6$ dissolved to give a yellow solution, and on warming to $60-70^{\circ}\text{C}$, almost all the solid dissolved, and the colour darkened. The tube was sealed

into a vacuum line system, cooled to -196°C and opened using a break seal. The carbon monoxide was collected and measured (96 ccs. at N.T.P., ~ 4 mmoles) and its identity confirmed by infrared spectroscopy and mass spectrometry. The excess aziridine was then vacuum transferred with a flask at -196°C containing dil. HCl and the tube finally removed from the vacuum line and the dark red tar extracted with chloroform. Recrystallisation gave a tar, which on washing with ether, gave a pink solid. The CHCl_3 solution infrared spectrum of the crude product showed absorptions at 1992 cm^{-1} ($\text{Cr}(\text{CO})_6$), and at $1981(\text{s})$, $1876(\text{sh})$ and $1826(\text{m})\text{ cm}^{-1}$. In the solid state infrared spectrum, the only sharp bands were the carbonyl absorptions (at $1898(\text{s})$, $1862(\text{sh})$ and $1818(\text{m})\text{ cm}^{-1}$). Other bands were broad and weak, but there was no band attributable to the ring deformation of ethyleneimine. Analytical data. Found: C, 39.6, 43.7, 42.7; H, 5.5, 7.8, 7.1%. The compound did not melt, but the colour paled to grey on heating to 300°C , in a sealed tube.

After storing for a few days at -20°C , the compound would not redissolve in CHCl_3 .

(b) $\text{Mo}(\text{CO})_6$ + Aziridine

The same reaction procedure was used as described for $\text{Cr}(\text{CO})_6$. When molybdenum hexacarbonyl (0.66 g., 2.5 mmoles) and excess aziridine (2 ml.) were heated at 100°C for several hours, a dark yellow solution was obtained, which on cooling, set to a gum. Carbon monoxide was collected and measured (102 ccs at NTP, ~ 4.5 mmoles). The gum dissolved in CHCl_3 but all attempts

to obtain a solid gave a dark yellow tar. Washing the tar with ether for several days gave a semisolid, whose infrared spectrum showed only weak, broad absorptions and no band due to ring deformation. Carbonyl absorptions in the solution spectrum of the crude solid were observed at 2016(w), 1896(s), 1869(sh), 1881(s), 1767(s), 1768(sh) cm^{-1} , but after storing for several days, the semisolid would not redissolve in CHCl_3 .

(c) W(CO)_6 + Aziridine

Heating tungsten hexacarbonyl (0.7 g., 2 mmoles) and aziridine (1.6 ml.) in a sealed tube at 110°C gave a dark yellow tar, but all the carbonyl did not react even after 3 days. On opening the tube, the CO was collected and measured (30 ccs., ~ 1.3 mmoles). The gum was insoluble in THF and ether, but gave a yellow solution with CHCl_3 , showing carbonyl absorptions at 1948(s) (W(CO)_6 ?), 1883(m), 1862(sh), 1812(w) cm^{-1} . Attempts to obtain a solid from the CHCl_3 solution yielded only a tar.

Results and Discussion

Several new carbonyl compounds were detected in reactions of manganese pentacarbonyl bromide and aziridine, but full characterisation of the products has not yet proved possible, since repetition of the reaction even under the same conditions gave different results, and mixtures of products were usually obtained.

Reaction between $\text{Mn(CO)}_5\text{Br}$ (1 mole) and aziridine (2 moles) gave complex I as the major product, and another complex II, obtainable only in small yield,

could be separated from I by sublimation. In the absence of a solvent, $\text{Mn}(\text{CO})_5\text{Br}$ and excess aziridine again gave complex I as the major product, but a third complex III, could be sublimed out of this sample of I. However, repetition of this reaction on a larger scale gave an insoluble product IV.

Reaction occurred between lithiumaziridine and $\text{Mn}(\text{CO})_5\text{Br}$, but the mixture of carbonyl species obtained could not be satisfactorily separated. On heating a solution of the products, one of the species disappeared, but attempts to obtain a solid from the solution gave only an oil, containing the solvent, and no reaction could be detected between this product and triphenylphosphine. When the Group VI metal carbonyls and excess aziridine were heated in a sealed tube, displacement of carbonyl groups occurred. Only in the case of $\text{Cr}(\text{CO})_6$ could a solid be isolated, but this changed on standing and has not yet been fully characterised. $\text{Mo}(\text{CO})_6$ and $\text{W}(\text{CO})_6$ gave tars, which could not be recrystallised.

Complex I is obtained as a yellow, microcrystalline solid. It decomposes slowly in air over several days, but more rapidly in solution. Refluxing a chloroform solution of I for 3 hrs. caused very little change in the solution infrared spectrum of the complex. On heating in a sealed tube, I darkened at 88°C and melted (with decomposition) at $110\text{-}112^\circ\text{C}$.

If ethyleneimine behaves as a normal weak base towards $\text{Mn}(\text{CO})_5\text{Br}$, then the expected product¹⁴¹ of the reaction is $\text{Mn}(\text{CO})_3\text{Az}_2\text{Br}$. Two moles of ligand were required for complete reaction of $\text{Mn}(\text{CO})_5\text{Br}$ (1 mole) in CHCl_3 . The infrared solution spectrum of I (in CHCl_3) shows carbonyl absorptions at

2037(s), 1932(s), 1916(s,sh) cm^{-1} (the shoulder is not always resolved) and this is the expected pattern for an octahedral, cis-disubstituted manganese tricarbonyl bromide complex²⁸³ (cf. cis-Mn(CO)₃py₂Br, ν_{CO} at 2031, 1950, 1911 cm^{-1} in CHCl₃). The bands in the infrared spectrum of complex I are listed in Table V.1, together with those of complex II, and ethyleneimine itself. Of particular note is the very strong band at 884 cm^{-1} due to the symmetrical ring deformation, and the N-H stretching frequency at 3115 cm^{-1} (shoulder at 3175 cm^{-1}). The latter is shifted to lower frequency, compared to its position in ethyleneimine itself, and this is consistent with electron withdrawal from nitrogen via the σ -bond upon co-ordination - similar shifts have been observed in morpholine and other complexes.³² Most of the other bands in the spectrum of I can be assigned to CH₂ modes, by comparison with the spectrum of ethyleneimine itself. Thus, the infrared spectrum strongly suggests that complex I is cis-Mn(CO)₃(Az)₂Br, in which the ethyleneimine co-ordinates to the metal via the nitrogen lone pair, and the 3-membered ring structure of the ligand is retained in the complex.

The analytical data obtained on two samples of complex I can be found in Section B.1. The figures obtained on each sample are inconsistent, but they do suggest that before sublimation, each sample has a higher carbon and nitrogen content than Mn(CO)₃Az₂Br requires. After sublimation, the carbon and nitrogen content of the recrystallised residue, I, is lower. (Average for I after sublimation: C,31.0; H,3.5; N,6.9; Br,25.7%. Mn(CO)₃Az₂Br requires: C,28.8; H,3.3; N,9.2; Br,26.2%). However, the figures are still not in good

Table V.1.

Infrared spectra of complexes I and II (Nujol mull) and of Ethyleneimine

(liquid smear)

I (cm^{-1})	II (cm^{-1})	$\text{C}_2\text{H}_5\text{N}$ (cm^{-1})	Assignment. 292
3175(sh) 3115(s)	3300(m)	3236(s) 3067(m)	N-H st. N-H st.
3012(w, sh) 2725(w) 2681(vw)		3003(s) 2899(vw)	CH_2 symmetrical and asymm. stretch
	2092(w)		CO st.
2033(vs)	2000(vs, br)		CO st.
1912(vs)	1946(s)		CO st.
1613(vw) 1527(vw)	1536(s)		
1447(s)		1451(w)	CH_2 deformation
1353(m) 1344(m)	1311(m)		
1264(w) 1232(s)	1261(w)	1266(w) 1218(s)	CH_2 twist ring breathing
	1190(vw)		
1111(vw)	1140(s)	1136(w)	CH_2 wag
1103(m)	1129(s)		
1086(s)	1075(vw)	1089(m)	CH_2 wag and twist
1026(w, br)	1020(vw)	1021(w)	N-H deformation
	970(m)		
940(m)		926(m)	assym. ring deformation
890(sh)	909(m)		
884(vs)	881(w)	856(vs)	symm. ring deformation
804(m, br)	800(vw, br)		
		785(s)	CH_2 rock
694(s)	719(vw, br)		
641(vs)	661(vs)		MCO bend
	627(s)		MCO bend ?
	602(w)		
535(vs)	554(w)		

agreement with those required by $\text{Mn}(\text{CO})_3\text{Az}_2\text{Br}$ and it is possible that all the impurities had not been removed, although the infrared solution spectrum of the residue, I, after sublimation showed that only one carbonyl species was present. It is not known whether the inconsistency of the analytical data is due to heterogeneity in the samples, to unsatisfactory analytical techniques for the type of compound, or to polymerisation.

The analytical data suggests that the sublimates II and III obtained from I must have a comparatively high carbon and nitrogen content. Only on one occasion was sufficient quantity of one of these species obtained for measurements to be made, and this compound (II) is discussed later. Infrared spectroscopy showed that II and III were both carbonyl complexes, but it is possible that the sublimates also contain some organic polymer formed from ethyleneimine either before or after complex formation.

Attempts to obtain a p.m.r. spectrum of I with TMS were unsuccessful, because of the formation of a precipitate when TMS was added as internal reference to a CDCl_3 solution of I, and no peaks were observed in the spectrum. The mass spectra of the complex obtained so far have not shown a parent peak. Peaks at lower m/e may be due to breakdown of $\text{Mn}(\text{CO})_3\text{Az}_2\text{Br}$, but it is difficult to make definite assignments since manganese is monoisotopic and no metastable peaks were observed.

Of the two sublimates obtained in the reactions between $\text{Mn}(\text{CO})_5\text{Br}$ and aziridine, the nature of III is unknown, since it was only isolated on one occasion in very small yield. Its infrared spectrum in the carbonyl region is similar to that of I, and is again characteristic of a cis-manganese

tricarbonyl bromide derivative. On one occasion, sufficient quantity of II was isolated to allow an infrared spectrum to be obtained in the solid state. The solution infrared spectrum of II (in CHCl_3) shows carbonyl bands at 2100(m), 2020(vs), 1970(s) cm^{-1} , and is characteristic of a trans tricarbonyl manganese bromide derivative.²⁸³ The solid state spectrum, shown in Table V.I differs considerably from that of I, and also from that of ethyleneimine. In particular, $\nu_{\text{N-H}}$ is shifted to higher frequency, and there is only a weak absorption in the 850-900 cm^{-1} range, where a strong absorption due to the symmetrical ring deformation should occur. The analytical and infrared data suggest that complex II is a trans-tricarbonyl manganese bromide derivative containing the ligand as a polymer. Mass spectra of the complex showed peaks to high m/e (524) but no parent peak could be identified, and no definite assignments made.

In one reaction between $\text{Mn}(\text{CO})_5\text{Br}$ and excess ethyleneimine, in the absence of a solvent, a large yield of a complex, IV was obtained. It seems that all the ethyleneimine must have been used to form the complex, to account for the yield, and polymerisation of the ligand must have occurred. A polymeric formulation for the compound is supported by its insolubility in all common organic solvents, and its stability in air. Surprisingly, the analytical data on the complex suggest a high bromine, rather than a high carbon content. The infrared spectrum (Nujol mull.) shows strong carbonyl absorptions at 2024 and 1919 (broad) cm^{-1} but other absorptions are weak and broad, and no band attributable to the ring deformation was observed.

When lithiumaziridine was reacted with $\text{Mn}(\text{CO})_5\text{Br}$, new carbonyl species were detected, and LiBr was probably eliminated, but the mixture could not be separated. Heating the solution caused some of the carbonyl bands to disappear, but attempts to isolate a solid gave only an oil, containing the solvent. The solutions of the complexes were very air-sensitive and reactive (they attacked the KBr plates used for infrared spectroscopy). However, no reaction between the product remaining after heating and PPh_3 was observed, when an attempt was made to produce a more stable derivative.

Ring opening of the ligand occurred in the reactions between the Gp.VI metal carbonyls and ethyleneimine. For the Mo and W carbonyls, new carbonyl derivatives were detected in solution but only tars could be isolated. A solid was obtained from the reactions with $\text{Cr}(\text{CO})_6$, but this seemed to change on standing, and the compound could not be fully characterised.

D. Conclusions

Reproducible results were not obtained in the reaction of $\text{Mn}(\text{CO})_5\text{Br}$ with ethyleneimine, although the main product seems to be the expected di-substituted compound, $\text{Mn}(\text{CO})_3\text{Az}_2\text{Br}$. This complex has not yet been satisfactorily purified. Other compounds were isolated in small yield in the reaction, and one of these contains the ligand with the ring opened. This compound could form from $\text{Mn}(\text{CO})_3\text{Az}_2\text{Br}$, or from reaction of $\text{Mn}(\text{CO})_5\text{Br}$ with some polymer present in the ethyleneimine itself. The former route is probably more likely, since in another reaction, extensive polymerisation of the ligand occurred to give a different polymeric compound. This poly-

merisation must have been catalysed by the carbonyl compound, but the reasons for the differences in behaviour of the ligand towards $\text{Mn}(\text{CO})_5\text{Br}$ are not clear.

Direct reaction of the Gp.VI metal carbonyls with some other amines also produced tars.⁸⁵ Derivatives containing the amine were obtained by reaction of the base with $\text{R}_4\text{N}^+[\text{M}(\text{CO})_5\text{X}]$ derivatives ($\text{M} = \text{Cr}, \text{Mo}, \text{W}$)⁸⁵ and this might provide a route to ethyleneimine derivatives of the Gp.VI metal carbonyls.

CHAPTER SIX

Reactions of Nitrite Salts with Transition Metal Carbonyls

A. Introduction

This chapter describes attempts to introduce the nitrite group into transition metal carbonyl systems. Numerous non-carbonyl nitrite complexes are known, and these are usually ionic e.g. $[\text{Me}_4\text{N}]^+_2[\text{Mn}(\text{NO}_2)_4]^{2-}$ ²⁹³ or contain other strong ligands e.g. $\text{Ni}[2\text{-(aminomethyl)piperidine}]_2(\text{NO}_2)_2$ ²⁹⁴, simple nitrites being rare. The nitrite group is a strong ligand, coming near to the cyanide anion in the spectrochemical series and since there are several stable carbonyl complexes known containing the cyanide group, or the thiocyanate and isothiocyanate groups, there seemed no reason why transition metal nitrites should not exist, especially since the NO_2 group possesses π -bonding capabilities which are of importance in formation of stable carbonyl derivatives. It was hoped to study the nitro \longleftrightarrow nitrito isomerism often observed in non-carbonyl systems, and also to investigate the possibility of reducing the nitrite group to the nitrosyl group whilst co-ordinated to the metal.

$\text{Mn}(\text{CO})_5\text{NO}_2$ had previously been prepared and characterised.^{140,295} It was isolated in small amounts as a side product in the reaction of $\text{Mn}_2(\text{CO})_{10}$ with N_2O_4 , the main product being $\text{Mn}(\text{CO})_5\text{NO}_3$. In addition, an insoluble, polymeric material obtained by the action of moist nitric oxide on $\text{Ru}_3(\text{CO})_{12}$ has been described as $[\text{Ru}(\text{CO})_2(\text{NO}_2)_2]_n$ ²⁰⁷ on the basis of infrared evidence. Manganese carbonyl compounds were investigated initially as $\text{Mn}(\text{CO})_5\text{NO}_2$ had already been prepared and also because maximum stability of

the metal carbonyl halides is attained with manganese compounds, and it seemed likely that $\text{Mn}(\text{CO})_5\text{NO}_2$ would be the most stable representative of this class of compounds.

B. Experimental

1. $\text{Mn}(\text{CO})_5\text{Br}$ + NaNO_2

Sodium nitrite (0.07 g., 1 mmole) was dissolved in methanol (25 ml.) and manganese pentacarbonyl bromide (0.32 g., 0.8 mmoles) was added. The yellow solution darkened on stirring at room temperature, and after several hours, the solvent was removed under vacuum. The brown oil remaining was extracted with CHCl_3 and new carbonyl absorptions were observed (at 2051(s) and 1970(s) cm^{-1}) but attempts to recrystallise the compound lead to decomposition.

2. $\text{Mn}(\text{CO})_5\text{Br}$ + $(\text{Me}_4\text{N})\text{NO}_2$

(a) Manganese pentacarbonyl bromide (0.2 g., 0.72 mmoles) in methanol (15 ml.) was heated with a methanol solution (20 ml.) of tetramethylammonium nitrite (0.1 g., 0.85 mmoles). The yellow solution darkened on stirring at room temperature and after several hours, the solvent was removed under vacuum, and the yellow-brown residue extracted with CHCl_3 . New carbonyl absorptions were detected and addition of hexane to the CHCl_3 solution gave a small amount of impure solid, which had no nitrite absorptions in the infrared spectrum.

When $\text{Mn}(\text{CO})_5\text{Br}$ and $(\text{Me}_4\text{N})\text{NO}_2$ were refluxed in diglyme for 4 hrs., gas evolution was observed and a brown solid precipitated. Filtration of the hot solution gave a colourless filtrate and the residue contained no carbonyl species, as determined by i.r. spectroscopy.

3. $\text{Mn(CO)}_5\text{Br} + \text{AgNO}_2$

Manganese pentacarbonyl bromide (0.2 g., 0.72 mmoles) in THF (20 ml.) was heated with excess silver nitrite. After stirring overnight at room temperature, protected from the light, no change was observed, but filtration and removal of solvent gave a yellow-orange solid, contaminated with black particles. The solid was recrystallised twice from CHCl_3 /hexane, but yielded a mixture of yellow and black solids. The yellow solid decomposed to the black solid, even at -20°C .

Repetition of the reaction in the more inert solvent, toluene gave the same contaminated product, but all attempts to obtain a pure sample of the yellow compound, by recrystallisation from toluene, CHCl_3 , or ether, were unsuccessful, and attempted sublimation caused rapid decomposition.

4. $\pi\text{-CpFe(CO)}_2\text{X} + \text{AgNO}_2$ (X = Cl, I)

No reaction occurred between $\pi\text{-CpFe(CO)}_2\text{Cl}$ and AgNO_2 in water.

Silver nitrite (0.38 g., 2.5 mmoles) was added to a dark yellow-black THF solution (20 ml.) of π -cyclopentadienyliron dicarbonyl iodide (0.3 g., 1 mmole) and the suspension stirred for 14 hrs. in darkness. No change was observed, and after filtration the residue was shown to be a non-carbonyl compound (by infrared spectroscopy). Removal of volatiles from the orange-brown filtrate gave a black tar, which on extraction with ether, gave an orange brown solid, contaminated with black particles. Recrystallisation from CHCl_3 or toluene pet. ether mixtures gave a black powder and orange crystals. Attempted sublimation (at room temperature), 0.001 mms/Hg onto a cold finger at -78°C)

gave no sublimate and caused the orange crystals to turn black.

Repetition of the reaction in toluene gave the same orange product, still contaminated with black particles, but infrared spectroscopy suggested the presence of a carbonyl nitrite compound, as well as $\pi\text{-CpFe(CO)}_2\text{I}$. The two carbonyl species were separated by chromatography. (Grade II acid Woelm alumina; elution with (i) 5:1 CHCl_3 :hexane gave mainly $\pi\text{-CpFe(CO)}_2\text{I}$, (ii) CHCl_3 gave the product). However, on removal of solvent from the latter solution, a darkening in colour was observed, and the yellow solid obtained was contaminated with black particles. When the product was chromatographed a second time, some dark solid remained at the top of the column and removal of solvent from the solution at 0°C still gave an impure product.

Addition of triphenylphosphine to a toluene solution of the product, in an attempt to produce a more stable derivative, caused extensive decomposition. Attempts were made to force the reaction between $\pi\text{-CpFe(CO)}_2\text{I}$ and AgNO_2 to go to completion. After stirring a toluene solution of $\pi\text{-CpFe(CO)}_2\text{I}$ and AgNO_2 for 14 hrs., the suspension was filtered and the filtrate heated with another portion of AgNO_2 . Repetition of this procedure gave no increase in yield of the product, and a small amount of $\pi\text{-CpFe(CO)}_2\text{I}$ remained in solution.

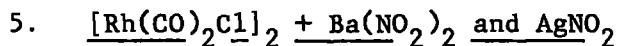

No reaction occurred between rhodium dicarbonyl chloride dimer and barium nitrite, nor between the carbonyl and silver nitrite, in toluene at room temperature.

6. Group VI metal carbonyls + (Me₄N)NO₂

(a) No reaction occurred between chromium hexacarbonyl and tetramethyl ammonium nitrite in refluxing diglyme over 14 hrs.

(b) A diglyme solution (60 ml.) of molybdenum hexacarbonyl (3.5 g., 1.3 mmoles) and tetramethylammonium nitrite (1.4 g., 1 mmole) was heated at 110-120°C for 5 hrs. Gas evolution was observed and the mixture darkened in colour. Filtration of the hot solution gave a non-carbonyl residue (as shown by infrared spectroscopy), but addition of petroleum ether (40-60°, 160 ml.) to the cooled filtrate gave a black tar. Extraction of this tar with THF, filtration and removal of solvent gave a brown solid which was recrystallised from methanol/ether, to give an orange powder, whose infrared spectrum showed carbonyl absorptions. Analytical data on different samples of this complex: C, 25.1, 26.6, 21.2; H, 3.9, 4.9, 4.0; N, 5.4, 6.7, 5.5%.

(c) Reaction between tungsten hexacarbonyl and tetramethylammonium nitrite in diglyme, at 80°C for 3 hrs., produced total decomposition to a black solid, which was insoluble in all common organic solvents, or in water, and whose infrared spectrum showed no absorptions due to CO or NO₂ groups.

Results and Discussion

Several metal carbonyl systems have been studied in attempts to isolate transition metal carbonyl nitrite derivatives. In the reactions of Mn(CO)₅Br with nitrite salts, new carbonyl species were detected in solution but attempts to obtain a solid from the solutions caused decomposition of the carbonyl compound. A yellow product from the reaction between Mn(CO)₅Br and

AgNO₂ was isolated, but was always contaminated with its black decomposition product. No Mn(CO)₅NO₂ was detected in these reactions. Infrared spectroscopy showed that π-CpFe(CO)₂I and AgNO₂ gave some π-CpFe(CO)₂(NO₂) which was separated from the iodide by chromatography, but the compound was unstable in solution and in the solid state and could never be isolated free of its decomposition products. No reaction occurred between [Rh(CO)₂Cl]₂ and Ba(NO)₂ or AgNO₂, nor between Cr(CO)₆ and (Me₄N)NO₂. However, (Me₄N)NO₂ reacted with Mo(CO)₆ to give a carbonyl product, but with W(CO)₆, total decomposition to a grey, insoluble material occurred, which contained no carbonyl or nitrite groups.

The product from the reaction between π-CpFe(CO)₂I and AgNO₂ showed two strong carbonyl absorptions at 2071 and 2028 cm⁻¹ in the infrared spectrum, in CHCl₃ solution. These absorptions are at higher frequencies than the iodide (ν_{CO} 2047 and 2008 cm⁻¹) and slightly higher than π-CpFe(CO)₂Cl (ν_{CO} 2059 and 2018 cm⁻¹), suggesting that the NO₂ group is more efficient at removing charge from the metal than is the chloride group. The bands in the solid state spectrum (Nujol mull) are listed in Table VI.1 together with assignments. The full spectrum of the complex is very similar to that of π-CpFe(CO)₂Cl, apart from new absorptions at 1341, 1266 and 818 cm⁻¹, which, by comparison with other nitrite complexes are assigned to the NO₂ group (e.g. Mn(CO)₅NO₂²⁹⁵, ν_{NO₂} at 1388, 1327 and 817 cm⁻¹. [Ru(CO)₂(NO₂)₂]²⁰⁷, ν_{NO₂} at 1270, 1170 and 840 cm⁻¹). Thus, the product is believed to be π-CpFe(CO)₂NO₂, but no further information could be obtained, since the instability of the

compound prevented its purification.

Table VI.1.

Infrared spectrum (Nujol mull) of $\pi\text{-CpFe(CO)}_2\text{NO}_2$

Position cm ⁻¹	Assignment	Position cm ⁻¹	Assignment ²⁹⁶
3062(w)	$\pi\text{-C}_5\text{H}_5$	853(m)	$\pi\text{-C}_5\text{H}_5\text{-M}$
2057(s)	CO	835(w)	$\pi\text{-C}_5\text{H}_5\text{-M}$
2015(s)	CO	818(s)	NO ₂
1426(w)	$\pi\text{-C}_5\text{H}_5\text{-M}$	614(s)	$\pi\text{-C}_5\text{H}_5\text{-M}$
1341(s)	NO ₂	596(sh)	$\pi\text{-C}_5\text{H}_5\text{-M}$
1266(m)	NO ₂	588(ms)	$\pi\text{-C}_5\text{H}_5\text{-M}$
1099(w)	$\pi\text{-C}_5\text{H}_5\text{-M}$	546(ms)	$\pi\text{-C}_5\text{H}_5\text{-M}$
1066(w)	$\pi\text{-C}_5\text{H}_5\text{-M}$	532(m)	$\pi\text{-C}_5\text{H}_5\text{-M}$
1003(w)	$\pi\text{-C}_5\text{H}_5\text{-M}$		

In the reactions of $\text{Mn(CO)}_5\text{Br}$ with NaNO_2 , new carbonyl species were detected in solution, but all attempts to isolate them lead to decomposition. It is possible that the species formed were sodium salts, with solvent molecules co-ordinated to the cation. Farona²⁹⁷ reports that reaction of alkali metal salts in methanol or diglyme with $\text{Mn(CO)}_5\text{Br}$ lead to solvent insertion to give salts. Abel and co-workers²⁹⁸ found that similar reactions occurred with Group VI metal carbonyls, but all efforts to obtain crystalline salts caused decomposition. These authors report, however, that $(\text{R}_4\text{N})\text{Y}$ salts ($\text{Y} = \text{halogen}$, $\text{R} = \text{alkyl}$) with $\text{Mn(CO)}_5\text{X}$ compounds ($\text{X} = \text{halogen}$) react according to the equation:

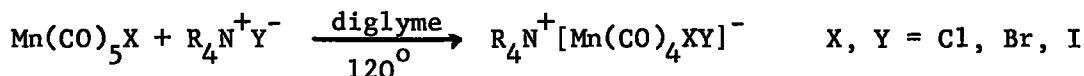

No evidence could be obtained for analogous behaviour for $\text{Y} = \text{NO}_2$, and no carbonyl species could be isolated, from this reaction.

The nitrite ion has been used to prepare nitrosyl derivatives of metal derivatives of metal carbonyls,¹⁸ e.g. Co(NO)(CO)_3 from $[\text{Co(CO)}_4]^-$ and NO_2^- and acetic acid, and $[\text{Fe(NO)(CO)}_3]^-$ from nitrites and Fe(CO)_5 . In the reaction of $\text{Mn(CO)}_5\text{Br}$ with AgNO_2 a solution spectrum of the crude mixture in CHCl_3 showed carbonyl bands at 2063 and 2049 (s, split), 1980 and 1961 (ms, split) cm^{-1} and a band at 1717(s) cm^{-1} , attributable to ν_{NO} ($\text{Mn(CO)}_3(\text{NO})(\text{PPh}_3)$)¹⁸ has ν_{NO} at 1713 cm^{-1} , ν_{CO} at 2034, 1971, 1926 cm^{-1}). However, no band was observed in the 1700 cm^{-1} region of the spectrum of the impure solid isolated from the reaction. This spectrum showed carbonyl absorptions at 2058(sh), 2046(s), 1990(sh), 1961(sh) and 1942(s) cm^{-1} and also bands at 1266(m) and 801(ms), possibly due to NO_2 . However, there were several other bands in the 1550-600 cm^{-1} region of the spectrum, which could not be assigned, and the nature of this unstable product is unknown.

$[\text{Rh(CO)}_2\text{Cl}]_2$ reacts with AgNO_3 , Ag_2SO_4 and AgSCN to give binuclear complexes containing ligand bridges²¹⁶, although AgCN and AgF do not react. No reaction could be detected between the carbonyl and either AgNO_2 or $\text{Ba(NO}_2)_2$ under similar conditions.

The difference in reactivity of the Gp.VI metal hexacarbonyls towards $(\text{Me}_4\text{N})\text{NO}_2$ is surprising, since they all react with $\text{R}_4\text{N}^+\text{X}^-$ salts to give

$R_4N^+[M(CO)_5X]$ (X = halogen).²⁹⁸ A new carbonyl compound could be isolated only in the reaction of $Mo(CO)_6$ with $(Me_4N)NO_2$. The product had the properties of a salt (soluble in acetone, H_2O , MeOH, EtOH, diglyme, THF, CH_3NO_2 ; insoluble in hydrocarbons, toluene, $PhNO_2$, ether) and its ionic nature was confirmed by a conductivity measurement (0.005 g. of the compound, in 10 ml. acetonitrile gave a reading of 4.3×10^{-4} mhos, compared to the solvent itself, which had a conductivity of 7.2×10^{-6} mhos). The infrared spectrum of the solid (Nujol mull) showed carbonyl absorptions at 2016(s,broad), 1932(sh), 1908 and 1987(s,split) cm^{-1} , bands at 1266(s) and 800(s), possibly due to NO_2 and bands at 1488(sh) and 952(m), due to Me_4N^+ . In addition, there were strong absorptions at 1748 and 1626 cm^{-1} , possibly due to a nitrosyl stretching frequency, but several unassigned bands appeared in the spectrum, and no meaningful interpretation of the data on this compound has been possible.

Conclusions

In most of the metal carbonyl nitrite systems studied, new species were detected in solution, but attempts to isolate compounds often lead to decomposition. In other cases, new compounds could be isolated, but were too unstable to be fully characterised. At least one of these compounds, $\pi-CpFe(CO)_2NO_2$ could be characterised as a nitrite derivative, by infrared spectroscopy. Some indication of the formation of nitrosyl carbonyl derivatives in some of the reactions, was obtained.

Appendix 1Experimental Details and Starting Materials

Most of the reactions described were carried out in an atmosphere of pure, dry nitrogen either in two-necked flasks or in double Schlenk tubes. Air sensitive materials were handled in a Glove Box, or if in solution, were transferred from one vessel to another by syringe against a counter current of nitrogen.

Nitrogen Supply

"White Spot" nitrogen direct from the cylinder was dried by passage through a trap maintained at -196°C and delivered to a multiple outlet system. A constant pressure of nitrogen was maintained in the system by connecting one outlet to an oil bubbler.

Glove Box

The nitrogen atmosphere in the Glove Box was purified by continuously recycling it through a trap at -196°C , through two furnaces at 400°C , containing copper wire and back to the box via a second trap at -196°C . Bench nitrogen was used, after passage through this system, to flush out the transfer tube. All external tubing was of copper or glass, and the gloves used were made of "Butasol" rubber. An oxygen level of less than 50 p.p.m. was maintained by this system.

Solvents

Solvents were usually degassed on the vacuum line before use. Hydrocarbon solvents were dried over sodium wire. Chloroform and diglyme were stored over CaCl_2 and distilled from CaCl_2 or P_2O_5 before use. Monoglyme and THF were used freshly distilled under nitrogen from LiAlH_4 .

Starting Materials

The majority of transition metal derivatives used as starting materials are readily available by methods described in the literature, e.g. $\text{Mn}(\text{CO})_5\text{Br}$, ref.272, $(\text{Ph}_3\text{P})_2\text{NiCl}_2$, ref.257. The ligands used were made using the methods in the literature, e.g. $\text{Ph}_2\text{C}=\text{NC}(\text{Cl})\text{Ph}_2$, ref.268. Commercial ethyleneimine (from Koch-Light Laboratories) was stored over NaOH pellets, to prevent polymerisation and used without further purification. Tetramethylammonium nitrite was prepared from Me_4NBr and KNO_2 and dried by pumping at 50°C for several hours.

Appendix 2
Instrumentation

Infrared Spectra

Infrared spectra in the range 2.5-25 microns were usually recorded on a Spectromaster, although a Grubb-Parsons GS2A prism grating spectrophotometer was sometimes used.

Spectra of solid samples were recorded in the form of Nujol mulls between KBr plates, the samples being made up in the Glove Box.

Liquid samples (generally solutions) were inserted into a solution cell (thickness 0.1 mm) by syringe and gas phase samples were recorded using a 10 cm. cell. Both cells had KBr windows, although CaF_2 windows were sometimes used for the solution cell.

Far Infrared Spectra

Far infrared spectra (21-50 μ) were recorded as Nujol mulls between CsI plates using a Grubb-Parsons DM2/DB3 prism grating spectrophotometer.

Nuclear Magnetic Resonance Spectra

Nuclear magnetic resonance spectra were recorded on a Perkin-Elmer R10 spectrometer, operating at 60 Mc/sec. Samples were usually in CDCl_3 solution, using tetramethylsilane (T.M.S.) as internal reference. The sample tubes were filled by syringe against counter current nitrogen, and were sealed under nitrogen.

Mass Spectra

Mass spectra were recorded on an A.E.I. MS9 mass spectrometer at 70 eV and an accelerating potential of 8 kv, with a source temperature between 60 and 300°C, and electromagnetic scanning. Compounds were introduced by direct insertion into the ion source.

Appendix 3
Analytical Methods

Carbon and Hydrogen

Carbon and hydrogen determinations were carried out by the departmental microanalyst using conventional combustion techniques. Carbon was also determined by oxidation to CO_2 using a mixture of oleum, phosphoric acid, chromic acid and potassium iodate. The CO_2 was measured in the usual way.

Samples containing nitrogen were analysed by Drs. Weiler and Strauss of Oxford, or in the department, nitrogen was determined using the Kjeldahl method.

Halogens

Analyses for chlorine and bromine were carried out by the departmental microanalyst by conventional potassium-fusion and titration methods.

Nickel

Nickel was determined gravimetrically, by precipitation with dimethylglyoxime from a neutral solution. The organic matter in the compound was first removed by oxidation with boiling A.R. concentrated nitric acid.

REFERENCES

1. J. Chatt, P.L. Pauson and L.M. Venanzi, "Organometallic Chemistry", (H. Zeiss, ed.), p.468. Reinhold, New York, 1960.
2. E.W. Abel, Quart. Rev. (London) 17, 133 (1963).
3. F. Calderazzo, R. Ercoli and G. Natta, Ref.16, p.1.
4. W. Hieber, W. Beck and G. Braun, Angew. Chem., 1960, 72, 795.
5. R.B. King, "Adv. in Organomet. Chem.", (F.G.A. Stone and R. West, ed.) 1964, 2, 157.
6. M.A. Bennet, Chem. Revs., 1962, 62, 611.
7. R.G. Guy and B.L. Shaw, "Adv. in Inorg. and Radiochem.", 1962, 4, 77.
8. P.M. Treichel and F.G.A. Stone, "Adv. in Organomet. Chem.", (F.G.A. Stone and R. West, ed.), 1964, 1, 143.
9. E.O. Fischer and H.P. Fritz, "Adv. in Inorg. and Radiochem.", 1959, 1, 56.
10. G. Wilkinson and F.A. Cottom, Progr. Inorg. Chem., 1959, 1, 1.
11. T.A. Manuel, "Adv. in Organomet. Chem.", (F.G.A. Stone and R. West, ed.) 1965, 3, 181, and references therein.
12. E.W. Abel and B.C. Crosse, Organomet. Chem. Revs., 1967, 2, 443.
13. G.R. Dobson, I.W. Stolz and R.K. Sheline, "Adv. In Inorg. and Radiochem." 1966, 8, 1.
14. W. Strohmeier, Angew. Chem. Int. Ed., 1964, 3, 730.
15. R.J. Angelici, Organomet. Chem. Revs., 1968, 3, 173.
16. "Organic Syntheses via Metal Carbonyls", (I. Wenderand and P. Pino, ed.) Interscience, Vol.1, 1968 (Vol.2 to be published), and references therein.
17. B.F.G. Johnson and J.A. McCleverty, Prog. Inorg. Chem., 1966, 7, 277.
18. W.P. Griffith, Adv. in Organomet. Chem., (F.G.A. Stone and R. West, ed.) 1968, 7, 211.

19. C.S. Kraihanzel and F.A. Cotton, *Inorg. Chem.*, 1963, 2, 533.
20. W. Hieber and K. Rieger, *Z. Anorg. Allgem. Chem.*, 1959, 300, 288.
21. W. Hieber, K. Englert and K. Rieger, *Z. Anorg. Allgem. Chem.*, 1959, 300, 295.
- 22a. W. Hieber and W. Beck, *Z. Anorg. Allgem. Chem.*, 1960, 305, 265.
- 22b. L.F. Dahl and C.H. Wei, *Inorg. Chem.*, 1963, 2, 328.
23. P.L. Pauson and A.R. Qazi, *J. Organomet. Chem.*, 1967, 7, 321.
- 24a. V. Frey, W. Hieber and O.S. Mills, *Z. Naturforsch.*, 1968, 23B, 105.
- 24b. L.F. Dahl, W. Costello and R.B. King, *J. Amer. Chem. Soc.*, 1968, 90, 5422.
25. S. Otsuka, T. Yoshida and A. Nakamura, *Inorg. Chem.*, 1967, 6, 20.
26. L.E. Orgel, "An Introduction to Transition Metal Chemistry: Ligand Field Theory", Wiley, New York, 1960.
27. F.A. Cotton, "Chemical Applications of Group Theory", Wiley (Interscience), New York, 1963.
28. E. Pitcher and F.G.A. Stone, *Spectrochim. Acta*, 1962, 18, 585.
29. R.J. Angelici, *J. Inorg. Nucl. Chem.*, 1966, 28, 2627.
30. A. Luttringhaus and W. Kullick, *Tetrahedron Letters*, 1959, 1, 13.
31. B.L. Ross, J.G. Grasselli, W.M. Ritchey and H.D. Kaesz, *Inorg. Chem.*, 1963, 2, 1023.
32. G.W.A. Fowles and D.K. Jenkins, *Inorg. Chem.*, 1964, 3, 257.
33. H. Behrens and J. Vogl, *Ber.*, 1963, 96, 2220.
34. R.J. Angelici, *Organomet. Chem. Revs.*, 1968, 3, 173, and references therein.
35. R.G. Pearson, *J. Amer. Chem. Soc.*, 1963, 85, 3533.
36. A. Rosenthal and I. Wender, Ref. 16, p.405, and references therein.

37. H. Behrens and K. Lutz, Z. Anorg. Allgem. Chem., 1967, 354 (3-4), 184.
38. W. Hieber, J. Peterhaus and E. Winter, Ber., 1961, 94, 2572.
39. H. Behrens and K. Lutz, Z. Anorg. Allgem. Chem., 1968, 356, 225.
40. H. Behrens, H. Brandl and K. Lutz, Z. Naturforsch., 1967, 22B, 99.
41. H. Behrens and H. Brandl, Z. Naturforsch., 1967, 22B, 1216, and references therein.
42. H. Behrens and N. Harder, Ber., 1964, 97, 433.
43. W. Hieber, K. Englert and K. Rieger, Z. Anorg. Allgem. Chem., 1959, 300, 304.
44. W. Hieber, W. Abeck and H.K. Platzler, Z. Anorg. Allgem. Chem., 1955, 280, 252.
45. H. Behrens and D. Herrmann, Z. Anorg. Allgem. Chem., 1967, 351, 225.
46. H.D. Murdoch and R. Henzi, J. Organomet. Chem., 1966, 5, 463.
47. H. Behrens and W. Klek, Z. Anorg. Allgem. Chem., 1957, 292, 151.
48. H. Behrens and W. Haag, Z. Naturforsch., 1959, 14B, 600.
49. R.J. Angelici and M.D. Malone, Inorg. Chem., 1967, 6, 1731.
50. H. Werner and R. Prinz, Ber., 1967, 100, 265.
51. R.J. Angelici and C.M. Ingemanson, Inorg. Chem., 1969, 8, 83.
52. W. Strohmeier, J.F. Guttenberger, H. Blumenthal and G. Albert, Ber., 1966, 99, 3419.
53. R.P. Stewart and P.M. Treichel, Inorg. Chem., 1968, 7, 1942.
54. C.M. Ingemanson and R.J. Angelici, Inorg. Chem., 1968, 7, 2646.
55. H. Behrens and J. Kohler, Z. Anorg. Allgem. Chem., 1959, 300, 51.
56. W. Strohmeier and K. Gerlach, Z. Naturforsch., 1960, 15B, 413.
57. W. Strohmeier, K. Gerlach and G. Matthias, Z. Naturforsch., 1960, 15B, 621.

58. W. Strohmeier and G. Schö^onauer, Ber., 1962, 95, 1767.
59. H. Behrens and W. Haag, Ber., 1961, 94, 312.
60. W. Strohmeier, K. Gerlach and D. von Hobe, Ber., 1961, 94, 164.
61. F.A. Cotton, Inorg. Chem., 1964, 3, 702.
62. W.A.G. Graham, Inorg. Chem., 1968, 7, 315.
63. W. Strohmeier and K. Gerlach, Ber., 1960, 93, 2087.
64. G. Natta, R. Ercoli, F. Calderazzo and E. Santambrogio, Chim. Ind. (Milan), 1958, 40, 1003.
65. W. Hieber and F. Mühlbauer, Z. Anorg. Allgem. Chem., 1935, 221, 337.
66. W. Hieber and F. Mühlbauer, Z. Anorg. Allgem. Chem., 1935, 221, 349.
67. W. Strohmeier, G. Matthias and D. von Hobe, Z. Naturforsch., 1960, 15B, 813.
68. E. Abel, M. Bennett and G. Wilkinson, J.Chem.Soc., 1959, 2323.
69. J.D. Munro and P.L. Pauson, J. Chem. Soc., 1961, 3484.
70. H. Behrens and W. Haag, Ber., 1961, 94, 320.
71. H. Behrens and N. Harder, Ber., 1964, 97, 426.
72. H. Behrens, E. Lindner and J. Rosenfelder, Ber., 1966, 99, 2745.
73. M.H.B. Stiddard, J. Chem. Soc., 1962, 4712.
74. H. Behrens and J. Kohler, Z. Anorg. Allgem. Chem., 1960, 306, 94.
75. F. Zingales, M. Graziani and U. Belluco, J. Amer. Chem. Soc., 1967, 89, 256.
76. M. Graziani, F. Zingales and U. Belluco, Inorg. Chem., 1967, 6, 1582.
77. D.P. Tate, K.R. Knipple and J.M. Augl, Inorg. Chem., 1962, 1, 433.
78. W. Strohmeier and G. Schö^onauer, Ber., 1961, 94, 1346.
79. W. Strohmeier and K. Gerlach, Z. Naturforsch., 1960, 15B, 622.

80. G.R. Dobson, M.F.A. El-Sayed, I.W. Stolz and R.K. Sheline, *Inorg. Chem.*, 1962, 1, 526.
81. I.W. Stolz, G.R. Dobson and R.K. Sheline, *Inorg. Chem.*, 1963, 2, 323.
82. A.G. Massey, *J. Inorg. Nucl. Chem.*, 1962, 24, 1172.
83. D.P. Tate, J.M. Augl and A. Buss, *Inorg. Chem.*, 1963, 2, 427.
84. H.D. Murdoch, R. Henzi and F. Calderazzo, *J. Organomet. Chem.*, 1967, 7, 441.
85. B.W. Cook, R. Jackson, R.G.T. Miller and D.T. Thompson, *J. Chem. Soc.*, 1969, 25.
86. F.A. Cotton and R.M. Wing, *Inorg. Chem.*, 1965, 4, 314.
87. F.A. Cotton and D. Richardson, *Inorg. Chem.*, 1966, 5, 1851.
88. G.R. Dobson and L.W. Houk, *Inorg. Chim. Acta*, 1967, 1, 287.
89. H. Saito, J. Fujita and K. Saito, *Bull. Chem. Soc. Japan*, 1968, 41, 359.
90. M.B.H. Stiddard, *J. Chem. Soc.*, 1963, 756.
91. L.W. Houk and G.R. Dobson, *J. Chem. Soc.*, 1966, 317.
92. L.W. Houk and G.R. Dobson, *Inorg. Chem.*, 1966, 5, 2119.
93. L.G. Hull and M.H.B. Stiddard, *J. Chem. Soc.*, 1968, 710.
94. J.F. Guttenberger and W. Strohmeier, *Ber.*, 1967, 100, 2807.
95. R.J. Angelici and J.R. Graham, *Inorg. Chem.*, 1967, 6, 988.
96. J.R. Graham and R.J. Angelici, *Inorg. Chem.*, 1967, 6, 992.
97. G.C. Faber and G.R. Dobson, *Inorg. Chim. Acta*, 1968, 2, 479.
98. R. Cotton and I.B. Tomkins, *Aust. J. Chem.*, 1967, 20, 13.
99. H. Behrens and J. Rosenfelder, *Z. Anorg. Allgem. Chem.*, 1967, 352, 61.
100. R. Kummer and W.A.G. Graham, *Inorg. Chem.*, 1968, 7, 310.
101. R.B. King and M.B. Bisnette, *J. Amer. Chem. Soc.*, 1964, 86, 5694.

102. R.B. King and M.B. Bisnette, *Inorg. Chem.*, 1966, 5, 300.
103. M.L.H. Green, T.R. Sanders and R.N. Whiteley, *Z. Naturforsch.*, 1968, 23B, 106.
104. D.C. Bradley and A.S. Kasenally, *Chem. Comm.*, 1968, 1430.
105. R.B. King and M.B. Bisnette, *Inorg. Chem.*, 1966, 5, 293.
106. E.O. Fischer and E. Moser, *J. Organomet. Chem.*, 1964, 2, 230.
107. P.M. Treichel, K.W. Barnett and R.L. Shubkin, *J. Organomet. Chem.*, 1967, 7, 449.
108. H. Behrens and N. Anders, *Z. Naturforsch.*, 1964, 19B, 767.
109. A. Wojcicki and M.F. Farona, *J. Inorg. Nucl. Chem.*, 1964, 26, 2289.
110. W. Beck and H.S. Smedal, *Angew. Chem. Int. Ed.*, 1966, 5, 253.
111. H. Behrens, R. Schwab and D. Herrmann, *Z. Naturforsch.*, 1966, 21, 590.
112. H. Behrens and D. Herrmann, *Z. Naturforsch.*, 1966, 21, 1234.
113. H. Behrens and D. Herrmann, *Z. Naturforsch.*, 1966, 21, 1236.
114. W. Beck, R.E. Nitzschmann and H.S. Smedal, *J. Organomet. Chem.*, 1967, 8, 547.
115. J.F. Guttenberger, *Ber.*, 1968, 101, 403.
116. J.F. Guttenberger, *Angew. Chem. Int. Ed.*, 1967, 6, 1081.
117. J.K. Ruff, *Inorg. Chem.*, 1969, 8, 86.
118. T.E. Sloan and A. Wojcicki, *Inorg. Chem.*, 1968, 7, 1268.
119. E. Lindner and H. Behrens, *Spectrochim. Acta*, 1967, 23A, 3025.
120. W. Strohmeier and H. Hellmann, *Z. Naturforsch.*, 1963, 18B, 769.
121. W. Strohmeier and H. Hellmann, *Ber.*, 1963, 96, 2859.
122. W. Strohmeier and H. Hellmann, *Ber.*, 1964, 97, 1877.
123. H. Bock and H. tom Dieck, *Z. Anorg. Allgem. Chem.*, 1966, 345, 9.

124. H. tom Dieck and H. Friedel, J. Organomet. Chem., 1968, 12, 1968, 173.
125. H. Bock and H. tom Dieck, Angew. Chem. Int. Ed., 1966, 5, 520.
126. H. Bock and H. tom Dieck, Ber., 1967, 100, 228.
127. H. Bock and H. tom Dieck, Z. Naturforsch., 1966, 21B, 739.
128. E.O. Fischer and R. Aumann, Angew Chem. Int. Ed., 1967, 6, 181.
129. E.O. Fischer and R. Aumann, Ber., 1968, 101, 963.
130. K. Farmery and M. Kilner, J. Organomet. Chem., 1969, 16, p.51.
131. R. Cotton, G.R. Scollary and I.B. Tomkins, Aust. J. Chem., 1968, 21, 15.
132. D.C. Bradley and A.S. Kasenally, Chem. Comm., 1968, 1430.
133. W. Hieber and W. Schropp, Z. Naturforsch., 1960, 15B, 271.
134. W. Hieber, W. Beck and G. Zeitler, Angew. Chem., 1961, 73, 364.
135. H. Behrens, E. Ruyter and H. Wakamatsu, Z. Anorg. Allgem. Chem., 1967, 349, 241.
136. T. Kruck and M. Hoffler, Ber., 1963, 96, 3053.
137. T. Kruck and M. Hoffler, Ber., 1964, 97, 2289.
138. W. Hieber and W. Schropp, Z. Naturforsch., 1959, 14B, 460.
139. E.W. Abel and G. Wilkinson, J. Chem. Soc., 1959, 1501.
140. C.C. Addison and M. Kilner, J. Chem. Soc.(A), 1966, 1249.
141. R.J. Angelici and F. Basolo, J. Amer. Chem. Soc., 1962, 84, 2495.
142. K.A. Kelbys and A.H. Filbey, J. Amer. Chem. Soc., 1960, 82, 4204.
143. R.J. Mawby, F. Basolo and R. Pearson, J. Amer. Chem. Soc., 1964, 86, 3994.
144. C.S. Kraihanzel and P.K. Maples, Inorg. Chem., 1968, 7, 1806.
145. R.J. Angelici and D.L. Denton, Inorg. Chim. Acta, 1968, 2, 3.
146. W. Strohmeier, J.F. Guttenberger and H. Hellmann, Z. Naturforsch., 1964, 19B, 353.

147. W. Strohmeier and H. Hellmann, Z. Naturforsch., 1964, 19B, 164.
148. W. Strohmeier and K. Gerlach, Z. Naturforsch., 1960, 15B, 675.
149. W. Strohmeier and J.F. Guttenberger, Ber., 1963, 96, 2112.
150. W. Strohmeier and J.F. Guttenberger, Ber., 1964, 97, 1256.
151. W. Strohmeier, J.F. Guttenberger, H. Blumenthal and G. Albert, Ber., 1966, 99, 3419.
152. E.O. Fischer and M. Gerberhold, Experientia Suppl., 9, 1964, 259, (Chem. Abstracts, 1965, 62, 579f).
153. W. Strohmeier and J.F. Guttenberger, Z. Naturforsch., 1963, 18B, 80.
154. E.W. Abel, M.A. Bennet and G. Wilkinson, J. Chem. Soc., 1959, 2323.
155. A. Wojcicki and M.F. Farona, Inorg. Chem., 1964, 3, 151.
156. M.F. Farona and A. Wojcicki, Inorg. Chem., 1965, 4, 857.
157. M.F. Farona and A. Wojcicki, Inorg. Chem., 1965, 4, 1402.
158. W. Hieber and L. Schuster, Z. Anorg. Allgem. Chem., 1956, 287, 214.
159. E.W. Abel, G.B. Hargreaves and G. Wilkinson, J. Chem. Soc., 1968, 3149.
160. W. Hieber and H. Fuchs, Z. Anorg. Allgem. Chem., 1941, 248, 269.
161. W. Hieber, W. Oparsky and W. Rohm, Ber., 1968, 101, 2244.
162. T. Kruck and M. Noack, Ber., 1964, 97, 1693.
163. F. Zingales, M. Graziani, F. Faraone and U. Belluco, Inorg. Chim. Acta, 1967, 172.
164. F. Zingales, U. Sartorelli, F. Canziani and M. Raveglia, Inorg. Chem., 1967, 6, 154.
165. F. Zingales, U. Sartorelli and A. Trovati, Inorg. Chem., 1967, 6, 1246.
166. W. Hieber and G. Floss, Ber., 1957, 90, 1617.
167. W. Hieber and N. Kahlen, Ber., 1958, 91, 2223.
168. W. Hieber and A. Lipp, Ber., 1959, 92, 2075.

169. W. Hieber and W. Beutner, Z. Naturforsch., 1960, 15B, 324.
170. W. Hieber and W. Beutner, Z. Anorg. Allgem. Chem., 1962, 317, 63.
171. W. Hieber and W. Beutner, Angew. Chem. Int. Ed., 1962, 1, 116.
172. W. Hieber and W. Beutner, Z. Anorg. Allgem. Chem., 1962, 319, 285.
173. R.A. Plowman and F.G.A. Stone, Inorg. Chem., 1962, 1, 518.
174. E.O. Fischer and E. Moser, J. Organomet. Chem., 1965, 3, 16.
175. K.K. Joshi and P.L. Pauson, Proc. Chem. Soc., 1962, 326.
176. K.K. Joshi, P.L. Pauson, A.R. Qazi and W.H. Stubbs, J. Organomet. Chem., 1964, 1, 471.
177. T.A. Manuel, Inorg. Chem., 1964, 3, 1703.
178. W. Flannigan, G.R. Knox and P.L. Panson, Chem. and Ind., 1967, 1094.
179. J.A. Jarvis, B.E. Job, B.T. Kilbourn, R.H.B. Mais, P.G. Owston and P.F. Todd, Chem. Comm., 1967, 1149.
180. J. Piron, P. Piret and M. Van Meerssche, Bull. Soc. Chim. Belges, 1967, 76, 505.
181. M.M. Bagga, P.E. Baikie, O.S. Mills and P.L. Panson, Chem. Comm., 1967, 1106.
182. P.E. Baikie and O.S. Mills, Chem. Comm., 1967, 1228.
183. P.E. Baikie and O.S. Mills, Chem. Comm., 1966, 707.
184. P.E. Baikie and O.S. Mills, Inorg. Chim. Acta, 1967, 1, 55.
185. D. Bright and O.S. Mills, Chem. Comm., 1967, 245.
186. M. Dekker and G.R. Knox, Chem. Comm., 1967, 1243.
- 186a. R.J. Doedens, Inorg. Chem., 1968, 7, 2323.
- 186b. R.J. Doedens, Inorg. Chem., 1969, 8, 570.
187. A. DeCian and R. Weiss, Chem. Comm., 1968, 6, 348.
188. S. Otsuka, A. Nakamura and T. Yoshida, J. Organomet. Chem., 1967, 7, 339.

189. R.B. King and M.B. Bisnette, *Inorg. Chem.*, 1966, 5, 306.
190. R.B. King and K.H. Parnell, *J. Amer. Chem. Soc.*, 1968, 90, 3984.
191. T.A. Manuel and T.J. Meyer, *Inorg. Chem.*, 1964, 3, 1049.
192. I. Rhee, M. Ryang and S. Tsutsumi, *Chem. Comm.*, 1968, 455.
193. E. Koerner, V. Gustorf and M.J. Jim, *Z. Naturforsch.*, 1965, 20B, 521.
194. E.K. Gustorf, M.C. Henry, R.E. Sacher and C. Dipietio, *Z. Naturforsch.*, 1966, 21B, 1152.
195. H. Behrens and W. Aquila, *Z. Naturforsch.*, 1967, 22B, 454.
196. L. Busetto and R.J. Angelici, *Inorg. Chim. Acta*, 1968, 2, 391.
197. W.F. Edgell, M.T. Young, B.J. Bulkin, R. Bayer and N. Koizumi, *J. Amer. Chem. Soc.*, 1965, 87, 3080.
198. W.F. Edgell and B.J. Bulkin, *J. Amer. Chem. Soc.*, 1966, 88, 4839.
199. B.J. Bulkin and J.A. Lynch, *Inorg. Chem.*, 1968, 7, 2654.
200. R.J. Irving, *J. Chem. Soc.*, 1956, 2879.
201. W. Hieber and H. Hensinger, *J. Inorg. Nucl. Chem.*, 1957, 4, 179.
202. L.A.W. Hales and R.J. Irving, *J. Chem. Soc. (A)*, 1967, 1933.
203. M.I. Bruce and F.G.A. Stone, *J. Chem. Soc. (A)*, 1967, 1238.
204. J.V. Kingston, J.W.S. Jamieson and G. Wilkinson, *J. Inorg. Nucl. Chem.*, 1967, 29, 133.
205. T.A. Stephenson and G. Wilkinson, *J. Inorg. Nucl. Chem.*, 1966, 28, 945.
206. R. Cotton and R.H. Farthing, *Aust. J. Chem.*, 1967, 20, 1283.
207. J.P. Chandlin, K.K. Joshi and D.T. Thompson, *Chem. and Ind.*, 1966, p.1960.
208. H. Behrens and H. Wakamatsu, *Ber.*, 1966, 99, 2753.
209. W. Hieber and J. Ellerman, *Ber.*, 1963, 96, 1643.
210. W.D. Horrocks and R.C. Taylor, *Inorg. Chem.*, 1967, 6, 1663.

211. E.P. Ross and G.R. Dobson, *Inorg. Chem.*, 1967, 6, 1256.
212. H. Behrens and W. Aquila, *Z. Anorg. Allgem. Chem.*, 1967, 356, 8.
213. S. Otsuka, A. Nakamura and T. Yoshida, *Inorg. Chem.*, 1968, 7, 261.
214. Y. Matsu-ura, N. Yasuoka, T. Ueki, N. Kasai and M. Kakudo, *Chem. Comm.*, 1967, 1122.
215. W. Hieber, H. Hensinger and O. Vohler, *Ber.*, 1957, 90, 2425.
216. D.N. Lawson and G. Wilkinson, *J. Chem. Soc.*, 1965, 1900.
217. R. Ugo and F. Bonati, *Rend. Inst. Lombardo Sci. Lett. A*, 1964, 98, 548, (*Chem. Abstracts*, 1967, 66, 34346V).
218. R. Ugo and F. Bonati, *Inorg. Chim. Acta*, 1968, 2, 463.
219. M.A. Jennings and A. Wojcicki, *Inorg. Chem.*, 1967, 6, 1854.
220. W. Hieber and V. Frey, *Ber.*, 1966, 99, 2607.
221. M. Angoletta, *Gazz. Chim. Ital.*, 1959, 89, 2359, (*Chem. Abstracts*, 1961, 55, 7136e).
222. M. Angoletta, *Gazz. Chim. Ital.*, 1960, 90, 1021, (*Chem. Abstracts*, 1961, 55, 25565i).
223. L. Malatesta and L. Naldini, *Chem. Abstracts*, 1963, 58, 224c.
224. F. Bonati and R. Ugo, *J. Organomet. Chem.*, 1967, 7, 167.
225. R. Ugo, G.L. Monica and S. Cenini and F. Bonati, *J. Organomet. Chem.*, 1968, 11, 159.
226. I.I. Chernyaev and Z.M. Novozhenyuk, *Zh. Neorg. Khim.*, 1966, 11, 2603, (*Chem. Abstracts*, 1967, 66, 43289f).
227. V.G. Albano, P.L. Bellon and M. Sansoni, *Inorg. Chem.*, 1969, 8, 298.
228. W. Hieber, J. Ellermann and E. Zahn, *Z. Naturforsch.*, 1963, 18B, 589.
229. W. Hieber, F. Mühlbauer and E.A. Ehmann, *Ber.*, 1932, 65, 1090.
230. H. Bock, *Angew. Chem. Int. Ed.*, 1962, 1, 550.
231. H. Bock and H. tom Dieck, *Ber.*, 1966, 99, 213.

232. K. Krogman and R. Mattes, *Angew. Chem. Int. Ed.*, 1966, 5, 1046.
233. J. Burianora and Z. Burianec, *Collection Czech. Chem. Comm.*, 1963, 28, 2138.
234. A.D. Hel'man and M. Banman, *Compt. Rend. Acad. Sci. U.S.S.R.*, 1939, 68, 645.
235. R.J. Irving and E.A. Magnusson, *J. Chem. Soc.*, 1956, 1860.
236. R.J. Irving and E.A. Magnusson, *J. Chem. Soc.*, 1957, 2018.
237. A.R. Brause, M. Rycheck and M. Orchin, *J. Amer. Chem. Soc.*, 1967, 89, 6500.
238. E.A.V. Ebsworth, *Chem. Comm.*, 1966, 530.
239. L-H. Chan and E.G. Rochow, *J. Organomet. Chem.*, 1967, 9, 231.
240. I. Pattison and K. Wade, *J. Chem. Soc. (A)*, 1967, 1098.
241. P.L. Pickard and T.L. Tolbert, *J. Org. Chem.*, 1961, 26, 4886.
242. B. Bogdanovic, *Angew. Chem. Int. Ed.*, 1965, 4, 9544.
243. P.L. Pickard and G.W. Jolly, *J. Amer. Chem. Soc.*, 1954, 76, 5169.
244. K. Wade and B.K. Wyatt, Personal Communication.
245. I. Pattison, Ph.D. Thesis, University of Durham, 1967, p.81.
246. L.R. Ocone, J.R. Soulen and B.P. Block, *J. Inorg. Nucl. Chem.*, 1960, 15, 76.
247. D.E. Billing and A.E. Underhill, *J. Chem. Soc. (A)*, 1968, 29.
248. F.A. Cotton and G. Wilkinson, "Advanced Inorganic Chemistry", Interscience.
249. N.S. Gill, R.S. Nyholm, G.A. Barclay, T.I. Christie and P.J. Pauling, *J. Inorg. Nucl. Chem.*, 1961, 18, 88.
250. A. Misona, T. Osa and S. Koda, *Bull. Chem. Soc. Japan*, 1968, 41, 373.
251. K. Farmery, Ph.D. Thesis, University of Durham, 1968.

252. K. Farmery and M. Kilner, Personal Communication.
253. J.R. Jennings, I. Pattison, K. Wade and B.K. Wyatt, J.Chem.Soc.(A), 1967, 1608.
254. B.K. Wyatt, Ph.D. Thesis, University of Durham, 1968.
255. C. Summerford and K. Wade, Personal Communication.
256. S.M. Nelson and T.M. Shepherd, J. Chem. Soc., 1965, 3276, and references therein.
257. G. Garton, D.E. Henn, H.M. Powell and L.M. Venanzi, J. Chem. Soc., 1963, 3625.
258. R.J. Kern, J. Inorg. Nucl. Chem., 1962, 24, 1105.
259. R.J. Kern, J. Inorg. Chem., 1963, 25, 5.
260. L.M. Vallarino, W.E. Hill and J.V. Quaglino, Inorg. Chem., 1965, 4, 1598, and references therein.
261. M. Kilner and C. Midcalf, Personal Communication.
262. M. Pankowski and M. Bigorgne, C.R. Acad. Sc. Paris, 1967, 264, 1382.
263. Y.L. Baay and A.G. MacDiarmid, Inorg. Nucl. Chem. Letters, 1967, 3, 159.
264. A.P. Hagen and A.G. MacDiarmid, Inorg. Chem., 1967, 6, 686.
265. W. Hieber, J. Sedlmeier and W. Abeck, Ber., 1953, 86, 700.
266. W. Hieber and J. Sedlmeier, Ber., 1954, 87, 25.
267. B. Samuel and K. Wade, Chem. Comm., 1968, 1081.
268. B. Samuel and K. Wade, J. Chem. Soc.(A), 1969, In Press.
269. M.L.H. Green and P.L.I. Nagy, "Adv. in Organomet. Chem.", (F.G.A. Stone and R. West, ed.), 1964, 2, 325.
270. G. Wilkie et al., Angew. Chem. Int. Ed., 1966, 5, 151.
271. M.L.H. Green in "Organometallic Compounds", (Vol.II), by G.E. Coates, M.L.H. Green and K. Wade, p.39.

272. R.B. King, "Organometallic Syntheses", (J.J. Eisch and R.B. King, ed.), Vol. I, "Transition Metal Compounds"
273. K. Nakanishi, "Infrared Absorption Spectroscopy - Practical", Holden-Day, Inc., San Francisco.
274. W.R. McClellan, H.H. Hoehn, H.N. Cripps, E.L. Muetterties and B.W. Howk, J. Amer. Chem. Soc., 1961, 83, 1601.
275. T.B. Jackson and J.O. Edwards, Inorg. Chem., 1962, 1, 398.
276. T.B. Jackson and J.O. Edwards, J. Amer. Chem. Soc., 1961, 83, 355.
277. T.B. Jackson, M.J. Baker, J.O. Edwards and D. Tutas, Inorg. Chem., 1966, 5, 2046.
278. J. Scherzer, P.K. Phillips, L.B. Clapp and J.O. Edwards, Inorg. Chem., 1966, 5, 847.
279. C.R. Hanson, W.R. Brason, P.S. Skell, S.W. Kantor and A.E. Brodhag, J. Amer. Chem. Soc., 1956, 78, 1653.
280. C.E. Coffey, J. Amer. Chem. Soc., 1961, 83, 1623.
281. W. Hieber, G. Faulhaber and F. Theubert, Z. Anorg. Allgem. Chem., 1962, 314, 125.
282. R.J. Angelici, Inorg. Chem., 1964, 3, 1099.
283. R.J. Angelici, F. Basolo and A.J. Poe, J. Amer. Chem. Soc., 1963, 85, 2215.
284. V. Valenti, F. Cariati, C. Forese and G. Zerbi, Inorg. Nucl. Chem. Lett., 1967, 3, 237.
285. R.M. Acheson, "An Introduction to the Chemistry of Heterocyclic Compounds" (Interscience), 1960, p.14.
286. R. Snaith and K. Wade, Personal Communication.
287. C-H. Wang and S.G. Cohen, J. Amer. Chem. Soc., 1957, 79, 1924.
288. J.E. Earley, C.E. O'Rourke, L.B. Clapp, J.O. Edwards and B.C. Lawes, J. Amer. Chem. Soc., 1958, 80, 3458.
289. H.G. Konnecke and M. Heise, J. Prakt. Chem., 1959, 9, 232.

290. H.W. Heine, *Angew. Chem. Int. Ed.*, 1962, 1, 528.
291. A.F. Graefe and R.E. Meyer, *J. Amer. Chem. Soc.*, 1958, 80, 3939.
292. W. Potts, *Spectrochim. Acta*, 1965, 21, 511.
293. D.M.L. Goodgame and M.A. Hitchman, *J. Chem. Soc.(A)*, 1967, 612.
294. L. El-Sayed and E.O. Ragsdale, *Inorg. Chem.*, 1967, 6, 1640.
295. M. Kilner, Ph.D. Thesis, University of Nottingham, 1963.
296. R.S. Piper, F.A. Cotton and G. Wilkinson, *J. Inorg. Nucl. Chem.*, 1955, 1, 165.
297. M.F. Farona, A.C.S. 152nd Meeting, 0, 092.
298. E.W. Abel, I.S. Butler and J.G. Reid, *J. Chem. Soc.*, 1963, 2068.

