



Durham E-Theses

Allenic and acetylenic intermediates in organic synthesis

Punja, Nazim Fatehali Habib

How to cite:

Punja, Nazim Fatehali Habib (1967) *Allenic and acetylenic intermediates in organic synthesis*, Durham theses, Durham University. Available at Durham E-Theses Online: <http://etheses.dur.ac.uk/8521/>

Use policy

The full-text may be used and/or reproduced, and given to third parties in any format or medium, without prior permission or charge, for personal research or study, educational, or not-for-profit purposes provided that:

- a full bibliographic reference is made to the original source
- a [link](#) is made to the metadata record in Durham E-Theses
- the full-text is not changed in any way

The full-text must not be sold in any format or medium without the formal permission of the copyright holders.

Please consult the [full Durham E-Theses policy](#) for further details.

ALLENIC AND ACETYLENIC INTERMEDIATES
IN ORGANIC SYNTHESIS

A THESIS
SUBMITTED FOR THE DEGREE
OF
DOCTOR OF PHILOSOPHY
IN THE
UNIVERSITY OF DURHAM

BY
NAZIM FATEHALI HABIB PUNJA, B.Sc.(LONDON)

SEPTEMBER 1967



Acknowledgments

The author wishes to express his gratitude to his supervisor, Professor S.R.Landor, for his constant help, advice and encouragement throughout the course of these investigations.

The author also wishes to thank Parke, Davis & Co., Fourah Bay College, University of Sierra Leone, and his family for financial assistance to enable him to carry out this work.

ABSTRACT

Dihalocarbenes were added to allenes to form dihalo-methylene-cyclopropanes which were then converted by the n-butyl lithium method to cumulenes. Both dichloro- and dibromocarbenes were found to add to the allene double bond with the highest number of alkyl substituents.

Propargyl alkenylmalonates were prepared in good yields and pyrolysed under carefully controlled conditions to give allenic alkylidenemalonates in fair yields by Cope Rearrangement, but gave fission products under more extreme conditions. The position of the alkyl substituents on the alkenylmalonate group seemed to influence the ease of the rearrangement.

Cyclopropanes were prepared in good yields from different types of α, β -unsaturated esters by the dimethylsulphoxonium methyllide reaction in dimethyl sulphoxide and dimethylformamide solvents. An allenic ester, on the other hand, gave an unstable complex postulated as dimethylsulphoxonium 3-ethoxycarbonyl 2-methylallylide.

The syntheses of the only two naturally-occurring unconjugated straight-chain allenic acids, octadeca-5,6-dienoic acid ("Laballenic acid") and 8-hydroxy-5,6-dienoic acid, were attempted. Laballenic acid was synthesised and its absolute configuration determined via the lithium aluminium hydride reduction of hexadec-2-en-4-yn-1-ol and malonate condensation of the bromide from hexadeca-3,4-dien-1-ol. A similar reduction of 1-tetrahydropyranyloxy-hex-2-yn-4-en-6-ol, however, yielded a mixture of hexa-4,5-dien-1-ol and hex-4-yn-1-ol due to the elimination of the tetrahydropyranyl^{oxy} group.



CONTENTS

<u>Section</u>	<u>Index</u>	<u>Page</u>
I	<u>INTRODUCTION:</u>	
	1. Addition of Dihalocarbenes to Allenes	7
	2. Cumulenes	16
	3. Cope Rearrangement	22
	4. Cyclopropanes from α -, β -unsaturated esters by the Dimethyl Sulphoxonium Methylide Reaction	28
	5. Naturally Occurring Unconjugated straight-chain Allenic Acids	32
II	<u>DISCUSSION:</u>	
	1. Addition of Dihalocarbenes to Allenes	38
	2. Cumulenes	50
	3. Cope Rearrangement of Propargyl-alkenylmalonates	55
	4. Cyclopropanes from α -, β -unsaturated carboxylic esters, malonates, ketones, and allene esters and cyanides	77
	5. Laballenic Acid	103
	6. 8-Hydroxy-octa-5,6-dienoic Acid	110
	7. δ -Chloro- γ -valerolactone	121
III	<u>EXPERIMENTAL</u>	
	1. Addition of Dihalocarbenes to Allenes:	
	(a) Preparation of Allenes	127
	(b) Dihalomethylenecyclopropanes	133
	2. Cumulenes	145
	3. Cope Rearrangement of Propargyl-alkenylmalonates:	
	(a) Alkylidenemalonates	149
	(b) Propargyl alkenylmalonates	153
	(c) Allenic alkylidenemalonates	158

<u>Section</u>	<u>Index</u>	<u>Page</u>
III	<u>EXPERIMENTAL</u> continued...	
	4. Cyclopropanes from α, β -unsaturated esters:	
	(a) Cyclopropane esters	166
	(b) Cyclopropanemalonates	175
	(c) Reaction with allene ester	184
	5. Naturally Occurring Allenic Acids:	
	(a) Laballenic Acid	187
	(b) 8-Hydroxy-octa-5,6-dienoic acid	198
	6. δ -Chloro- γ -valerolactone	203
IV		
	1. Infra-Red Spectra	207
	2. Ultra-Violet Spectra	234
	3. Nuclear Magnetic Resonance Spectra	239
	4. Gas Liquid Chromatography	252
	<u>REFERENCES</u>	254

(I)
INTRODUCTION

ACETYLENIC AND ALLENIC INTERMEDIATES IN ORGANIC SYNTHESIS

INTRODUCTION

Addition of Dihalocarbenes to Allenes

Doering and Hoffmann¹ first showed in 1954 that dichloro- and dibromocarbenes, formed from potassium t-butoxide and either chloroform or bromoform, could be trapped by alkenes and that this reaction gave cyclopropanes. Subsequently the kinetic studies of Hine and his co-workers² established the mechanism of this reaction.

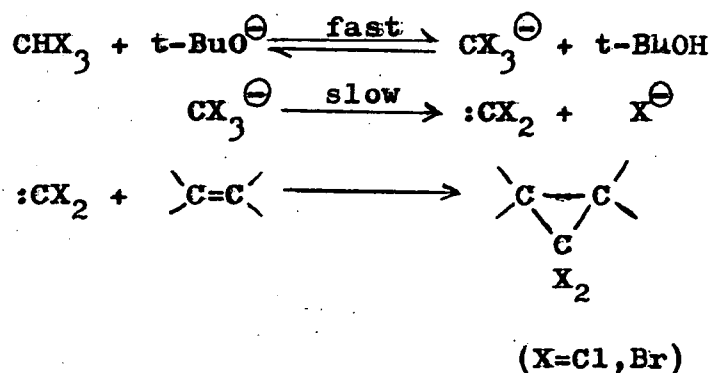

The synthetic potential of dihalocarbenes for the formation of cyclopropane derivatives was soon realised, and during the last ten years the formation and addition reactions of dihalocarbenes together with the kinetics and stereochemistry of these reactions have been extensively studied.

The following methods for generating dihalocarbenes in aprotic media are described in the literature:-

1. The action of potassium t-butoxide on haloforms¹ :-

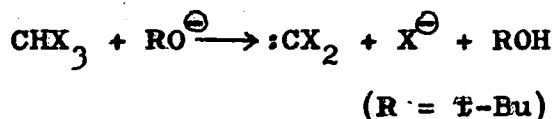

2. The reaction between an alkoxide base and (a) ethyl trichloroacetate³, or (b) hexahaloacetone⁴ :-

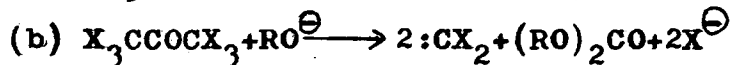
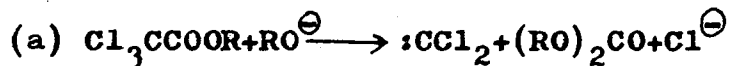

(R = Me, Et)

(X = Cl, F)

3. Halogen-metal exchange reaction between lithium-alkyls and tetrahalomethanes⁵ :-

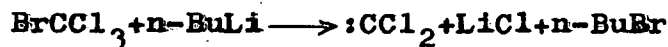

4. Thermal degradation of sodium trichloroacetate⁶ :-

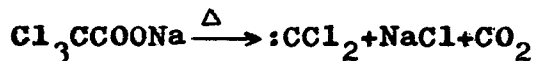

5. Thermal degradation of trihalomethylphenylmercury⁷ :-

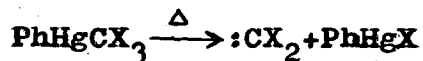

(X = Cl, Br)

The large majority of alkenes from which dihalocyclopropanes have been prepared are stable under strong basic conditions (i.e. 1-3). Alkenes which are unstable under basic conditions may be converted to cyclopropanes by the pyrolysis of sodium trichloroacetate and trihalomethyl-phenylmercury (i.e. 4-5), e.g. Wagner⁸ prepared 1,1-dichloro-2-(chloromethyl)-cyclopropane from allyl chloride by heating it with sodium trichloroacetate.

The dihalocarbene intermediate from the phenyltrihalomethylmercury appears to be more reactive than dihalocarbene generated by other methods and reacts with unreactive alkenes giving excellent yields of cyclopropanes as well as some products from C-H insertion reaction. Thus, tetrachloroethylene, which reacts only to a negligible extent with dichlorocarbenes generated by other methods, gave 74 per cent yield of hexachlorocyclopropane when reacted with phenyl-mercury-mono-bromo-dichloromethane⁹.

Reports in the literature¹⁰ show that the dihalocarbenes used to prepare dihalocyclopropanes contain either chlorine or bromine. Difluoro- and diiodocarbenes do exist, but the former are relatively stable and not particularly reactive¹¹, and even when they do react, give mixtures of products from addition and insertion reactions, while the latter form diiodocyclopropanes as unstable intermediates which cannot

be isolated¹. Recently, Oliver and Rao¹² confirmed the existence of diiodocarbenes by generating them from iodoform and potassium t-butoxide, and then preparing a diiodocyclopropane, and converting this immediately to the corresponding monoiodo-cyclopropane by reduction with tri-n-butyltin-hydride. The monoiodocyclopropane was stable enough to be isolated and identified.

The addition of dihalocarbenes to olefins has been shown by Doering and LaFlamme¹³, and by Skell and Garner¹⁴ to be a stereospecific cis-addition. They regarded the addition as being a concerted three-centre process. A charge separated intermediate would have to collapse to the cyclopropane faster than rotation could occur about a C-C single bond for the stepwise reaction to be stereospecific.

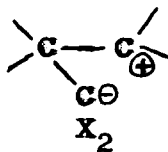

Thus it was shown that the addition of dihalocarbenes to cis- and trans-but-2-ene occurred with complete stereospecificity:-

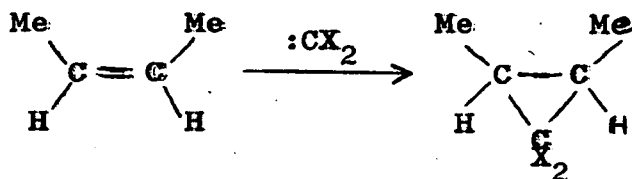

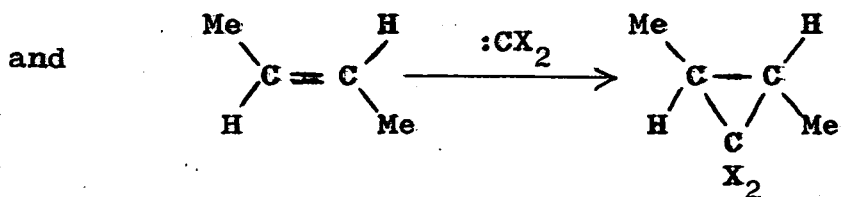

An alternative two-step mechanism involving the addition of a trihalocarbanion to the alkene with subsequent elimination of the halide ion was rejected^{13,14} as it neither explained the stereospecificity of the addition nor was it consistent with the function of the alkene as a nucleophile:-

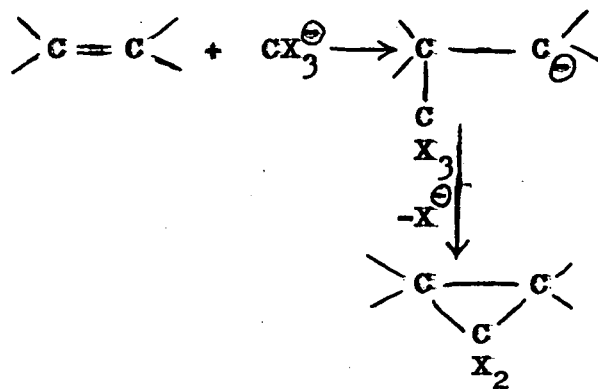

Furthermore it may readily be shown that carbanions and organometallic compounds do not react with non-polar double bonds. However, recently organometallic compounds bearing a halogen(X), e.g. $\text{ZnCH}_2\text{X}^{15}$ and $\text{R}_2\text{AlCH}_2\text{X}^{11}$ have been shown to react with alkenes to form cyclopropanes. Hoberg¹⁶ has therefore suggested that trihalomethyl anions might also display an increased reactivity towards double

bonds as compared with halogen-free carbanions, and that the reactions commonly designated as "dihalocarbene addition to olefins" may actually be due to the intermediate trihalocarbene anion.

Nevertheless, the following observations have strongly favoured the dihalocarbene addition mechanism rather than the displacement mechanism:-

(1) The base-catalysed reactions of haloforms with nucleophiles was shown to proceed by addition to the dihalocarbenes and not by displacement at the trihalocarbene anion.

The kinetic studies of Hine and co-workers² have established that added chloride ions would not produce a kinetic effect if trichlorocarbene anion is an intermediate, but would slow down the reaction if a dichlorocarbene was involved:-

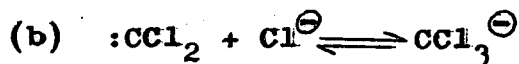
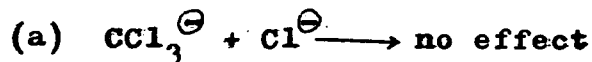

A slowing down of the over-all rate was observed. When bromide ions were used as nucleophiles instead of the chloride ions, a new trihalomethyl anion i.e. the monobromodichloromethyl ion was produced, thus confirming

the carbene mechanism; no new trihalomethyl anion would be expected if trichlorocarbanion was an intermediate.

(2) Kinetic studies of Franzen¹¹ showed that formation of difluorocarbene from the cyclohexene-dibromo-difluoromethane-n-butyl lithium system took place after all organometallic compounds had disappeared. Hence the following steps must take place:-

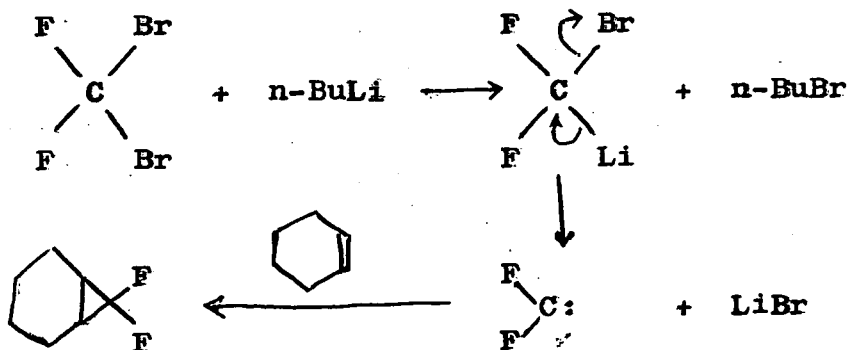

Doering and LaFlamme¹³, and Skell and Garner¹⁴ also showed that dihalocarbenes reacted preferentially with more nucleophilic alkenes, i.e. the dihalocarbenes are electrophiles. Competitive experiments in which dihalocarbenes were allowed to react with mixtures of alkenes demonstrated clearly that both dichloro- and dibromocarbenes showed a preference for reaction with olefins containing more electron-donating substituents. This electrophilic character of dihalocarbenes was further demonstrated by reactions with conjugated dienes, e.g.

with isoprene¹⁷, dihalocarbenes reacted preferentially at the methyl-substituted double bond:-

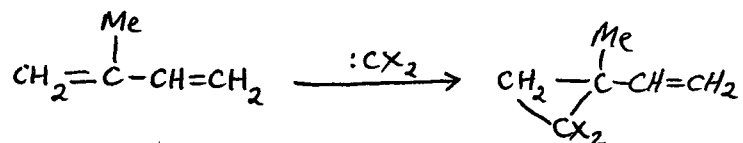

Skattebøl¹⁸, however, showed that in the reaction of dihalocarbenes with penta-1,3-diene, a 40-60 mixture of the two products was obtained:-

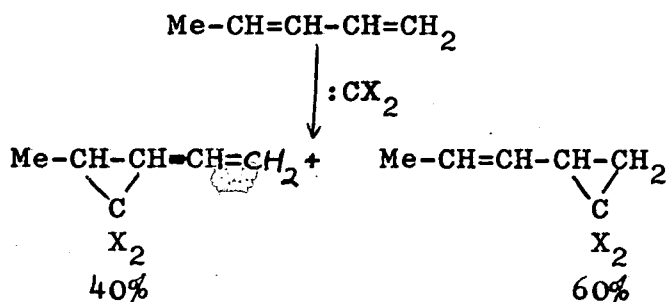

This predominant addition to the less-substituted double bond occurred only with dienes having terminal methyl substituents, e.g. penta-1,3-diene and 2,4-dimethyl-penta-1,3-diene, and this was rationalised in terms of an increase in the electron density of the terminal double bond due to the hyperconjugative effect of the methyl substituent.

Ball and Landor¹⁹ reported in 1961 that dibromocarbenes

always added across the allene double bond with the highest alkyl substituents:-

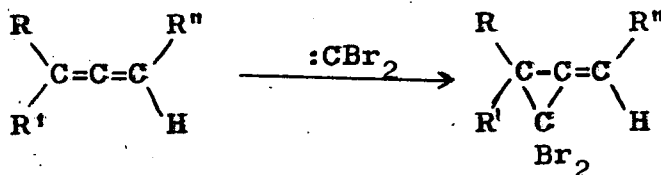

Bezagu²⁰ as well as VoQuang, VoQuang, Emptoz and Savignat²¹, however, reported that addition of dichloro-carbenes to allenes gave a mixture of two products:-

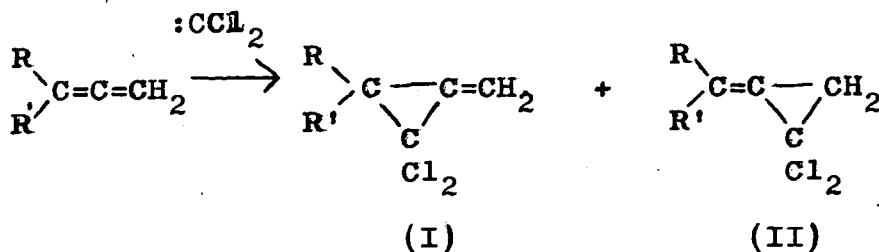

The presence of (II) was later²² thought to be due to thermal isomerisation of (I).

The work described in this thesis has shown that both dichloro- and dibromocarbenes react with allenes to give predominantly one product and that both dihalocarbenes add exclusively across the double bond with the highest number of alkyl substituents.

Insertion Reaction of Dihalocarbenes

Few reactions of dihalocarbenes afford products which are supposed to arise by insertion of dihalocarbenes into single bonds. Although the exact course of these reactions has not been fully elucidated, they do not proceed by the three-centre mechanism, e.g. optically active sec-butylbenzene was found to produce 2-methyl-2-phenyl-1,1-dichlorobutane with complete racemization.²³

It seems generally true that insertion reactions take place only when (i) the dihalocarbenes possess extra thermal energy, e.g. when generated by the pyrolysis of sodium trichloroacetate or phenyltrihalomethylmercury and (ii) when the dihalocarbenes cannot add on to the nucleophilic double bond of the olefin owing to some deactivation inherent in the alkene. The yield of the insertion product is generally poor.

Cumulenes

The name "Cumulene" was first proposed by Kuhn and Wallenfels²⁴ in 1938 for compounds containing three or more contiguous double bonds, $\text{>C(=C)}_n\text{<}$ ($n \geq 3$).

Although the first cumulenes were reported in the early twenties²⁵ it is only in the last few years that the development of the chemistry of acetylenes and allenes has given an impetus to the growth of the study of cumulenes.

The large majority of the cumulenes prepared so far are phenyl substituted ones. Aromatic groups on either side of the chain of double bonds in cumulenes tend to stabilise the whole system. Most of the aromatic cumulenes described in the literature²⁶ have been synthesised by reduction²⁷ (Method 1), dehydrohalogenation²⁸ (Method 2), or dehydration²⁴ (Method 3) of compounds having a suitable arrangement of substituents for elimination:-

Method 1

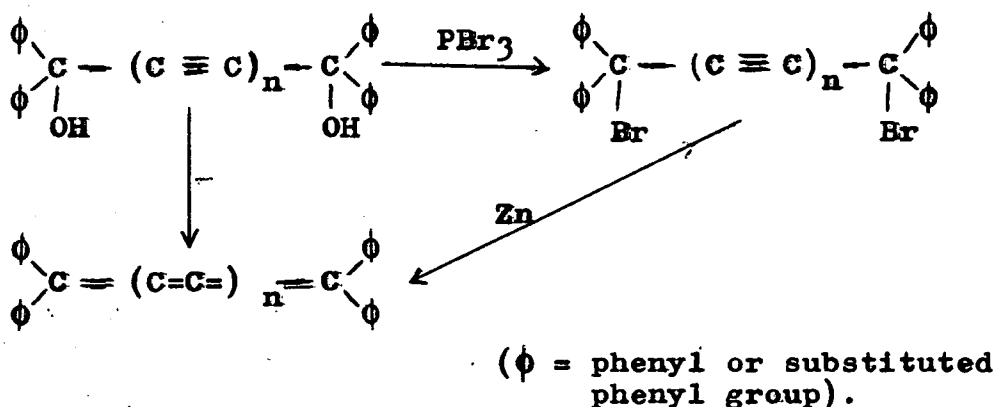

Method 2

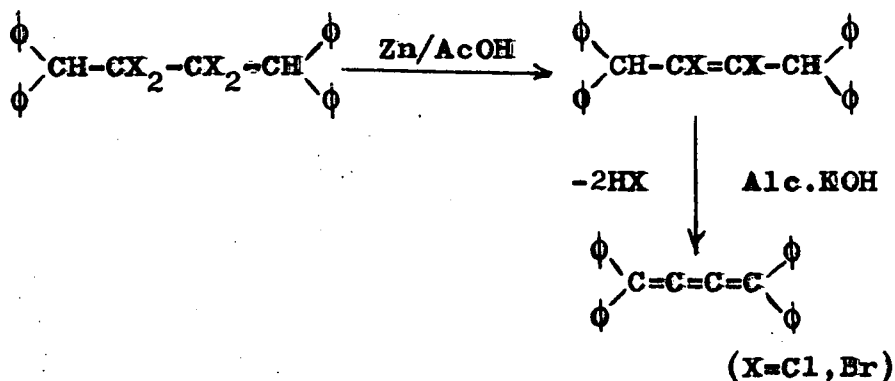

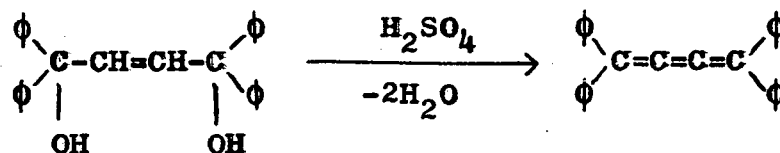
Method 3

Each method gives good yields of cumulenes of high purity. Most of these cumulenes are high melting crystalline solids and keep for a considerable time in the absence of oxygen.

Recently, ferrocenyl and chromium tricarbonyl systems²⁹ as substituents have also been shown to stabilise cumulene derivatives.

Few aliphatic cumulenes have been reported in the literature. The simplest cumulene, buta-1,2,3-triene, was first prepared in 1954³⁰ in 52-65 per cent yield by the reduction of 1,4-dibromo-but-2-yne with zinc. The cumulene was found to be very volatile and readily polymerizable. The exclusion of air throughout its preparation and identification was found to be vital. Catalytic hydrogenation yielded only polymeric materials, but hydration with 78 per cent sulphuric acid gave methyl vinyl ketone.

2,5-dimethylhexa-2,3,4-triene (II, n=1) was first prepared by Zalkind³¹ and, more recently, by Skattebøl³² from the reaction of 2,5-dichloro-2,5-dimethyl-hex-3-yne and magnesium bromide. The tetramethyl cumulene, a low

melting crystalline solid (m.p. 40°) was obtained in 92 per cent yield. It sublimed at $20^{\circ}/1$ mm. and was also sensitive to oxygen.

In a similar way Skattebøl also prepared 2,7-dimethyl-octa-2,3,4,5,6-pentaene (II, $n=2$), but found it to be very unstable.

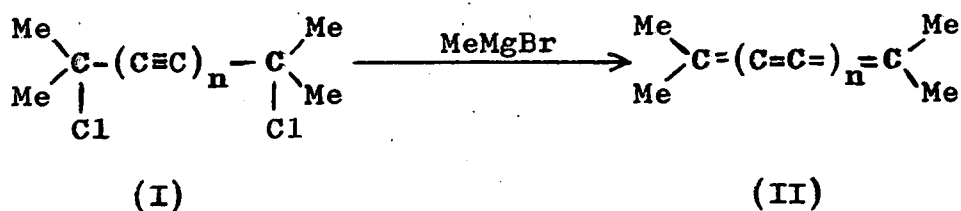

Maier³³, as well as Bond and Brodway³⁴ obtained the same cumulene (II, $n=1$) from the carbene intermediate generated from a tosylhydrazone:-

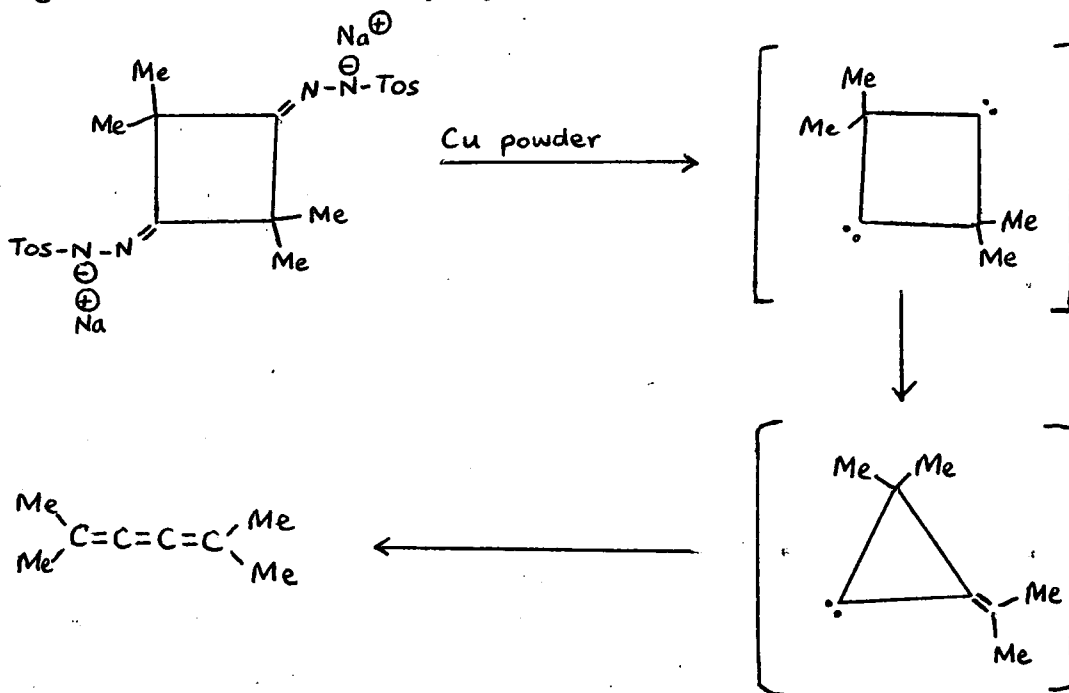

The first cumulene aldehyde⁴¹ (VI) was prepared in 1963 in 10-15 per cent yield by the action of potassium-hydrogen sulphate on 1-methoxy-6-methyl-hex-1-en-3-yn-5-ol (V):-

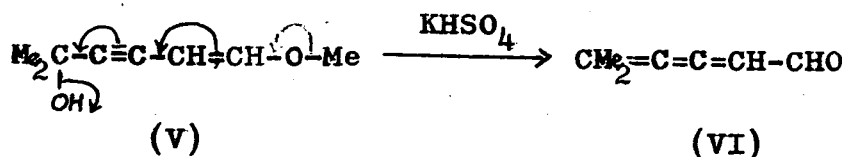

The cumulene aldehyde was identified by hydrogenation, elemental analysis and by the melting point of the 3,5-dinitrobenzoate of the saturated hydrogenated product corresponding to ~~iso-heptaldehyde~~ *isohexaldehyde*. Cumulene aldehyde (VI) had similar spectroscopic and chemical properties to the parent cumulene hydrocarbon³⁰ and the alkyl substituted cumulenes with terminal methylene group (VII) described in this thesis.

Work described in this thesis resulted in the preparation of the first alkyl substituted cumulenes with terminal methylene group (VII):-

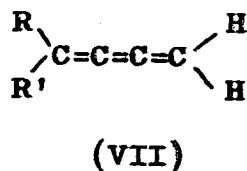

Cope Rearrangement

Cope and Hardy⁴² observed in 1940 that an α -allyl, α -vinyl-substituted cyanoacetate (I, R = COOEt, R' = CN) isomerised to an α, β -unsaturated cyanoacetate (II) on heating to 150-260°. They were able to show by degradation and analysis of the rearranged product that the isomerisation took place by a shift of the allyl group from α to β -position accompanied by a shift of the double bond from the β, γ - to the α, β -position.

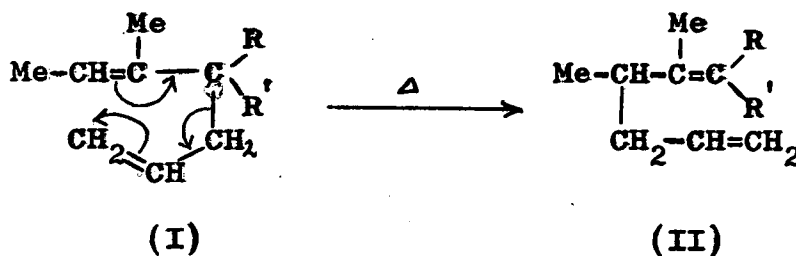

This was the first case reported of an allyl group undergoing thermally induced α, γ -shift in a three-carbon system. It was similar in type to Claisen rearrangement of allyl phenol, phenyl and vinyl ethers, and motivated by similar forces, as for instance (1) when the allyl group was replaced by an alkyl group the isomerisation did not take place even at much higher temperature. Hence the allyl group was essential. When ^{the allyl group was replaced by} a crotonyl group was replaced the ester also underwent rearrangement similarly. Hence

Levy and Cope⁴⁵ next considered 3-phenyl- and 3-methyl-1,5-hexadiene. The former rearranged smoothly at 165-185° to give 72 per cent yield of the expected rearranged product, while the latter did not rearrange at this temperature and rearranged only partially (20-30 per cent) when heated for 48 hours at 300°. Hence it was demonstrated that a single phenyl group provided sufficient activation for the rearrangement to occur while the difference in the activation energy in the latter case was so small that reverse reaction might also have occurred thus reducing the yield of the expected product:-

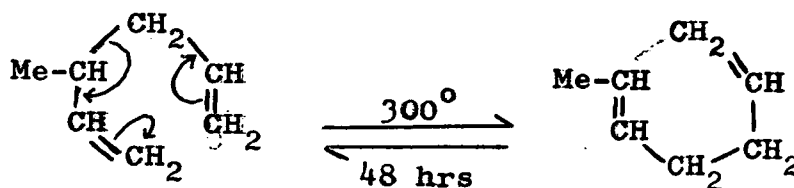

This established the fact that a negative group need not be present to weaken the bond between the allyl group and the carbon atom but that conjugation in the product from the rearrangement was essential.

Cope, Field and MacDowell⁴⁶ continuing this work reported in 1956 that compounds containing an allyl group and a benzenoid ring attached to a carbon atom substituted by two electron-attracting groups failed to

rearrange upon heating up to 290° with migration of the allyl group to an ortho position.

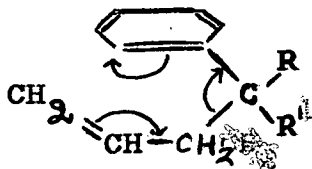

This behaviour is of course unlike that of phenolic ethers in the Claisen rearrangement.

Dimethyl (3,4-dimethoxy phenyl)-allyl malonate, in which the rearrangement of an allyl group to an ortho position might be facilitated by increased electron density from the methoxy substituents, also failed to undergo rearrangement up to 246° .

Replacement of ^{a phenyl group by} a phenanthrene group (as the 9,10-double bond of phenanthrene possesses more double bond character than the corresponding bond in benzene) also failed to rearrange to the required isomer.

Koch⁴⁷ reported that rearrangement of 3-4-diphenyl-1,5-hexadiene gave two products: trans-1,6-diphenyl-1,5-diene (III) and 1,4-diphenyl-1,5-hexadiene (IV) in the ratio 3:2, and he rationalised this in terms of two competing processes, i.e. the intramolecular ion - dissociative Cope rearrangement to give (III) and a homolytic dissociative process which gives mesomeric radicals that recombine to form (IV):-

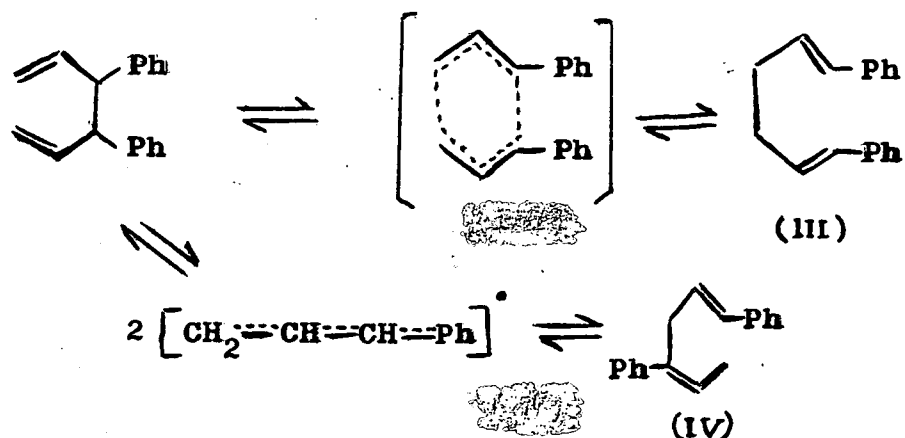

This was considered to provide an example of a "limiting" case of the Cope rearrangement in which the free energy of activation for the two reaction paths lie very close together. The mechanism is further discussed later in this thesis.

Recently a great deal of interest is focused on the stereochemical and conformational aspects of Cope rearrangement⁴⁸ involving multiple ring systems. Woodward and Katz⁴⁹ provided an excellent example of Cope rearrangement in which a diallyl system was contained in a bicyclic structure (V). When heated at 140° it was smoothly converted to the isomeric alcohol syn-8-hydroxy-dicyclopentadiene (VI) in good yield:-

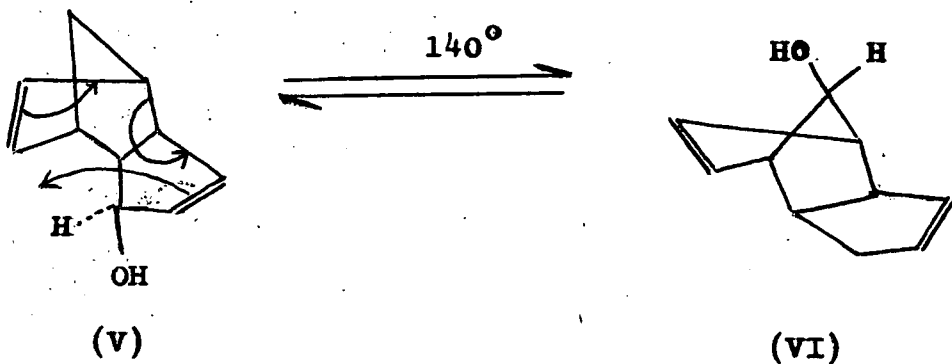

That the isomerisation was an equilibrium was established by the fact that (VI) gave the same equilibrium mixture under the same conditions.

Similarly, the β - isomer also rearranged smoothly and homogeneously to give anti-8-hydroxy-dicyclopentadiene.

It was also shown that the optical activity of the α - and β -isomers was retained in the products. Thus it was concluded that the facility with which Cope rearrangement occurs even without the benefit of activating groups was as a result of the favourable preorientation of the diallylic system imposed by the fixed geometry of the bicyclic structure:-

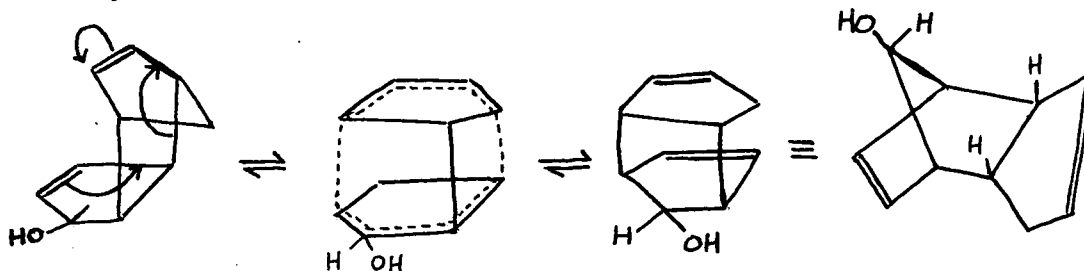

Lutz and Roberts⁵⁰ confirmed this result by isotopic labelling technique and showed that the rearranged product had retained its optical activity and only altered the site of the optical centre.

Doering and Roth⁵¹ in a similar way interconverted bicyclo-(5.1.0) - Octa-2,5-diene to the superimposable mirror image of itself, i.e. when using a fully symmetrical and completely reversible Cope rearrangement, and they

correlated the structural consequences by showing a similar rearrangement of the cis- and trans-conformations of 5,4-homotropilidene.

Cyclopropan-esters from the Reaction of Dimethylsulphoxonium Methylide and α,β -unsaturated esters

Corey and Chaykovski⁵² first showed in 1962 that dimethylsulphoxonium methylide (I) in dimethyl sulphoxide reacted with α,β -unsaturated ketones (II) which are susceptible to Michael addition to give cyclopropyl ketones (III):-

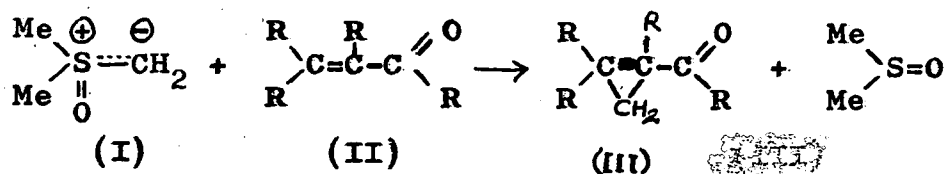

They were thus able to prepare 1-phenylcyclopropane phenyl ketone (IV) from benzalacetophenone, and cyclopropane derivative (V) from carvone in excellent yield.

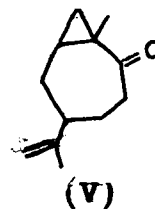
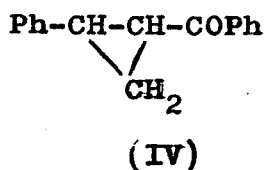

Izo⁵⁴ in 1963 prepared cyclopropane-dicarboximides (VII) by Corey and Chaykovski's method using (I) in tetrahydrofuran and maleimides (VI):-

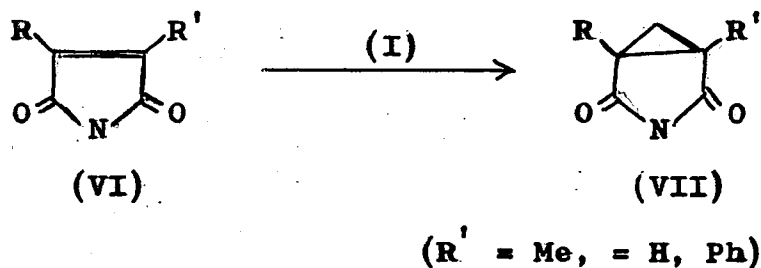

The reaction of dimethylsulphoxonium methylyde and α,β -unsaturated carbonyl compounds was extended in this laboratory to cover a wide range of α,β -unsaturated esters and malonates as well as allene esters and nitriles.

After this work was completed, the following reports were published:-

König, Metzger and Seeler⁵⁵ reported in 1965 the preparation of cis- and trans-2-phenylcyclopropane-nitrile from cis- and trans-cinnamyl nitrile:-

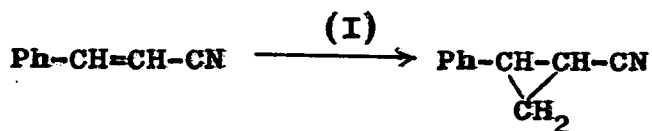

The same authors further showed that serbic acid-anilide (VIII) reacted with the methylyde (I) to give a mixture of a bis-cyclopropyl adduct (VIXI) and a pyrrolidone (IX):-

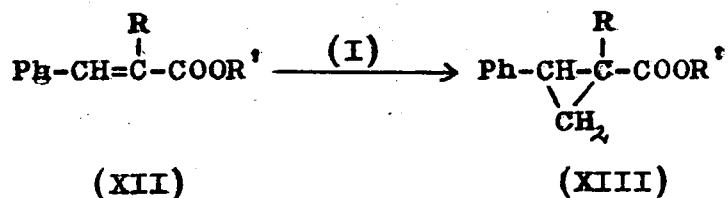

However, no cyclopropane derivative was obtained with ethyl-2-methyl-cinnamate (XII, R=Me, R'=Et). Diethyl benzalmalonate (XII, R=R'=COOEt) and diethyl-3,4-dimethoxybenzalmalonate gave good yield of the cyclopropane derivatives. This result was attributed to the function of the intermediate (XIV):-

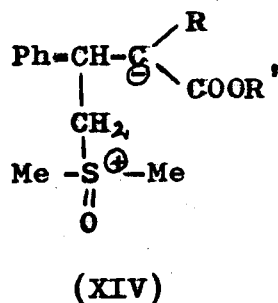

When R=H, R'=Et, small R' groups caused side reactions. When R=COOEt, R'=Et, the two ester groups provided to the intermediate anion sufficient stability which compensated for the added bulk and permitted cyclization.

They also showed that (I) reacted with an α, β -acetylenic ester, ethyl phenyl-propiolate (XV) to give a resonance-stabilised structure formulated as dimethyl sulphoxonium-3-ethoxycarbonyl-2-phenylallylide (XVI):-

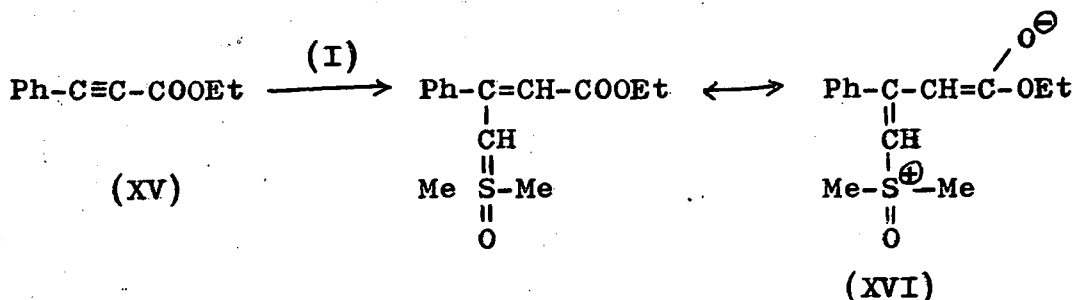

Ethyl prop-2-ynoate and ethyl but-2-ynoate by this method gave products which were too unstable to isolate and identify¹⁰².

In the same year, Corey and Chaykovski published their detailed paper⁵³.

Naturally Occurring Unconjugated Straight-chain Allenic Acids

A number of naturally occurring allenic acids have recently been isolated from plant origins, fungal cultures and micro-organisms¹⁶⁴. Celmer and Solomons⁵⁹ discovered the first naturally occurring allenic acid in 1952 and showed its structure to be (I).

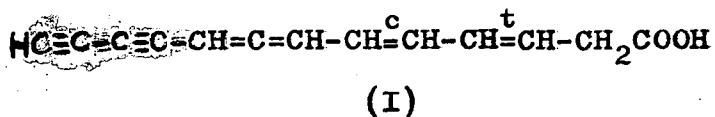

Following Anchel's discovery⁶⁰, Bu'Lock, Jones and Leeming⁶¹ isolated nemotinic acid (II, R=H) and its lactone nemotin (III, R=H) and proved their structures.

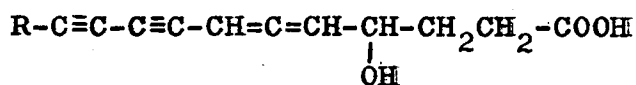

(II)

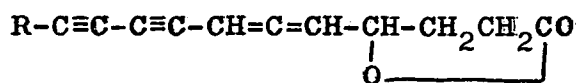

(III)

The same authors⁶² in 1957 elucidated the structures of odysaic acid (II, R=Me) and Odysain (III, R=Me).

Jones, Leeming and Reemers⁶³ in 1960 reported the isolation of a terminal allenic acid "Drosophilin D" (IV) and elucidated its structure.

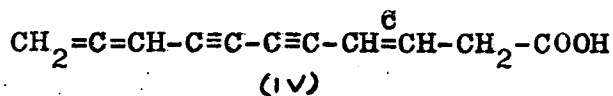

(IV)

Crombie, Hirschberg, Jones and Lower⁶⁴ isolated marasin (V) and its corresponding acid (VI, R=H) and methyl ester (VI, R=Me).

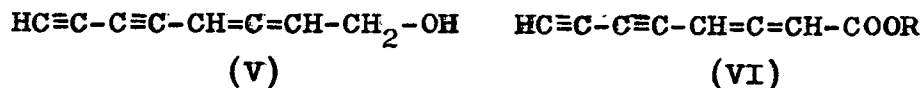

(V)

(VI)

All the above allenic acids have two features in common:- (i) they are all polyacetylenic allenic acids and (ii) they are conjugated.

The first report of the isolation of the methyl ester

of a non-conjugated allenic acid (VIII, R=Me) appeared in 1964. The allenic compound was a component of the seed oil of "Leonotis nepetaefolia" (family "Labiatae") and named by its investigators "Laballenic acid". The structure proposed for laballenic acid at that time was 2,3-methylene-4,5-heptadecadienoic acid (VII):-

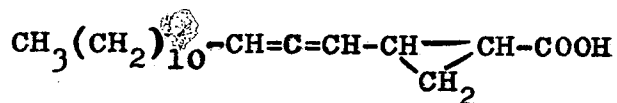

(VII)

In 1965, additional work by the same authors⁶⁶ showed that the correct structure of laballenic acid was (VIII, R=H) i.e. it was an isomer of tarric acid (IX), the first and simplest natural acetylenic acid discovered by Arnand⁶⁷ in 1892.

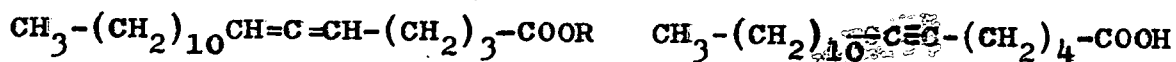

(VIII)

(IX)

The structure of (VIII, R=Me) was determined⁶⁶ by the following schemes:

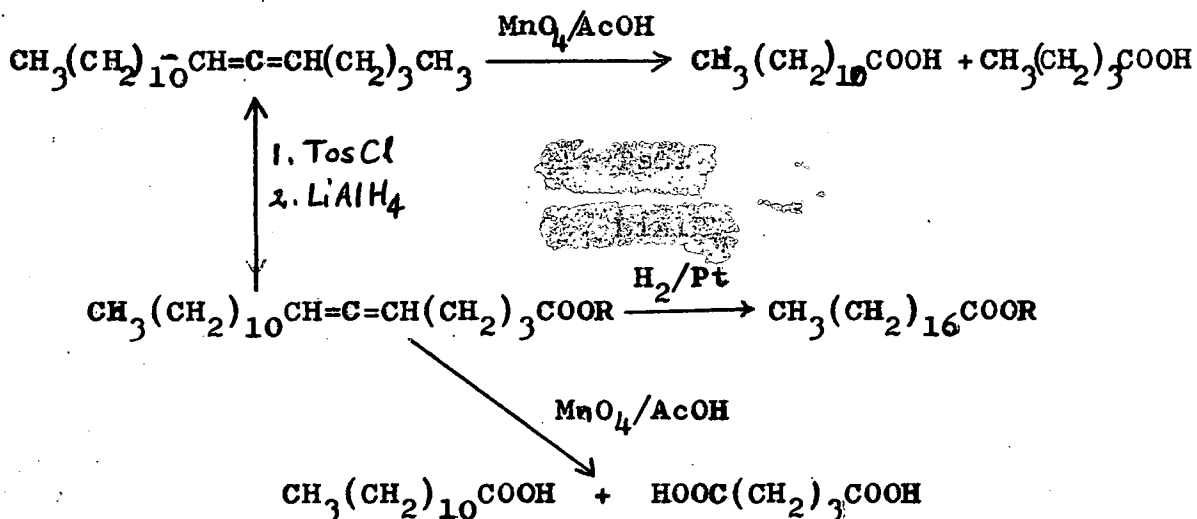

In the same year, Sprecher, Maier, Barber and Holman⁶⁸ reported the second naturally occurring non-conjugated allenic acid (X, R=H) obtained from a lipid which was extracted from the seed oil of the Chinese tallow tree "Sapium Sebiferum". The allenic acid was shown by mass spectral and chemical analyses to be 8-hydroxy-5,6-octadienoic acid (X, R=H) by the following scheme:-

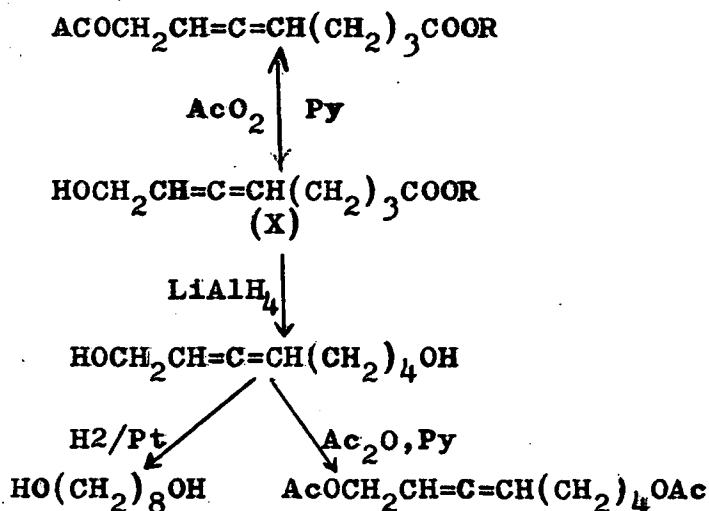

The methyl esters of these naturally occurring allenic acids (VIII,R=Me) and (X,R=Me) were optically active and exhibited optical rotation of $[\alpha]_D^{20} -47.3^\circ$ and -46.0° respectively.

(II)

DISCUSSION

DISCUSSION

Addition of Dihalocarbenes to Allenes

Dihalocarbenes are electrophiles and therefore add to the more nucleophilic double bond of diene hydrocarbons. The addition of dihalocarbenes to 1,3-dienes takes place at the double bond with the largest number of alkyl substituents, except where a terminal methyl group gives rise to a hyperconjugative effect in which case addition takes place at the less substituted double bond (see P 14)

The addition of dihalocarbenes to allenes can theoretically give three possible adducts:-

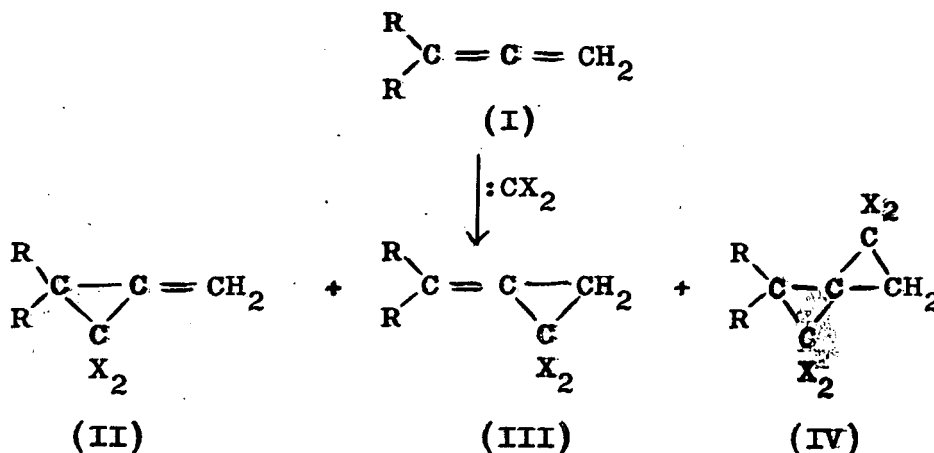

Ball and Landor¹⁹ showed in their preliminary report that dibromocarbenes always gave predominantly (II, X=Br) in 40-60 per cent yield. Skattebøl⁴⁰ reported that dibromo-

carbenes added to 2,4-dimethyl-2,3-pentadiene to give 67 per cent of the mono-adduct and 6 per cent of the bis-adduct, whilst dichlorocarbenes gave 73 per cent of the mono- and 3 per cent of the bis-adduct.

However, Bezaguet²⁰ claimed that dichlorocarbenes gave a mixture of (II, X=Cl) and (III, X=Cl), and in a subsequent publication, Bertrand and Bezaguet²² reported that (III, X=Cl) might have been formed due to thermal isomerisation of (II, X=Cl) during the distillation. No yields were reported. Similarly, VoQuong, VoQuong, Emptoz and Savignat²¹ reported that they also obtained (II, X=Cl) and (III, X=Cl) in 20-25 per cent and 10-15 per cent yields respectively.

A more extensive investigation of the addition of both dichloro- and dibromocarbenes to allenes is described here.

Preparation of Allenes

The following more important methods have been described in the literature for the preparation of the allenes required for this work:-

- (i) Dehydrobromination of a 1,2,3-tribromo derivative followed by removal of the bromine from the dibromo olefin with zinc⁵⁸.
- (ii) Prototropic rearrangement of acetylenes⁶⁹.
- (iii) Reduction of 1-bromo- or 1-chloroallenes or of 3-chloroacetylenes with zinc-copper couple⁷⁰ or

lithium aluminium hydride⁷¹.

(iv) Reaction of gem-dihalocyclopropanes with sodium on alumina⁷², magnesium in ether⁷³ or alkyl-lithium in ether⁷⁴.

Methods (i) and (ii) are long, tedious and give poor yields. Method (iv) employing methyl- or butyl-lithium gives an excellent yield but involves three steps, i.e. preparation of the olefin, dihalocyclopropane and allene. A recent modification of this method whereby the last two steps were carried out in a single experiment (i.e. without isolating the dihalocyclopropane) using carbontetrabromide and alkyl-lithium is reported⁷⁷ to give a good over-all yield of the allene.

Method (iii) was found to be the most convenient as most of the acetylenic alcohols were either commercially available or easily prepared by ethynylation of aldehydes or ketones using sodium acetylide in liquid ammonia. This method, first employed by Ginzburg⁷⁰ has two modifications:-

(a) Hennion and Sheehan⁷⁵ prepared chloroacetylenes from acetylenic alcohols using concentrated hydrochloric acid (for tertiary acetylenic alcohols) or thionyl chloride and pyridine (for secondary acetylenic alcohols), and by Ginzburg's procedure, reduced the pure chloroacetylenes

with zinc-copper couple in ethanol to give mainly the required allene hydrocarbons (Jacob⁷⁸ has reported improved yield of chloroacetylenes by using various ethers instead of pyridine in combination with thionyl chloride).

(b) Bailey and Pfeifer⁷⁶ did not purify the chloroacetylenes but reduced the crude product with lithium aluminium hydride in dioxan to obtain 50-55 per cent of the required allene hydrocarbons (Jacob⁷¹ also used lithium aluminium hydride to reduce the purified chloroacetylenes and chloroallenes to give the same allenes in approximately the same yield as obtained by Ginzburg using zinc-copper^{couple} (in ethanol)).

Bailey and Pfeifer claimed that the zinc-copper couple method was inferior to their modified method for the following reasons:-

(1) The yields of pure chloroacetylenes could not be high because some hydrogen chloride was eliminated during the distillation and some rearrangement to allenic chloride occurred. It was therefore best not to distil the chloroacetylene but to use the crude material directly for reduction.

(2) The final product of reduction always contained the isomeric acetylenic hydrocarbon which had to be

removed by a separate step or by careful fractionation.

(3) Alcohol used in the reduction very often formed an azeotrope with the allene, necessitating additional purification steps.

and (4) Zinc-copper couple was very tedious to prepare.

As a result of many experiments it was found during our investigation that the best yield was obtained by a modification of the Ginzburg method. In our experience the crude chloroacetylene could be readily prepared in near quantitative yield from tertiary acetylenic alcohols by shaking with concentrated hydrochloric acid and checking for the hydroxyl band in the i.r. at 3400 cm.^{-1} as a criterion for the alcohol content, and this procedure was continued until no alcohol could be detected (15-30 min.) Equimolar quantities of thionyl chloride and pyridine were used for preparing 3-chloro-hex-1-yne from hex-1-yn-3-ol in near quantitative yield. The crude chloroacetylene which contained some chloroallene was dried with anhydrous potassium carbonate, and was found to be perfectly satisfactory for reduction without any further purification as both isomers have been shown to yield the same allene by the Ginzburg method⁷¹.

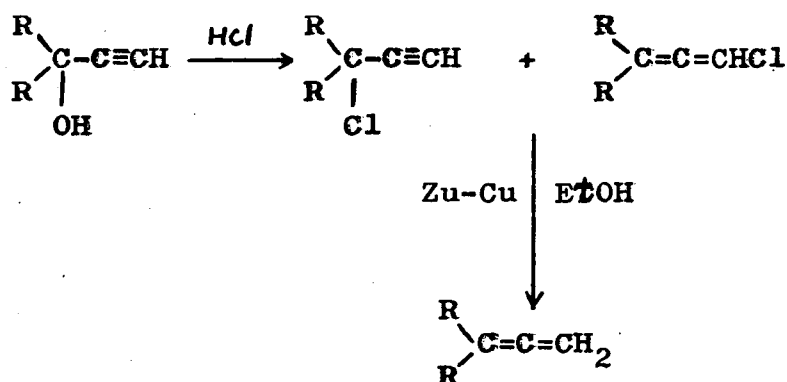

The zinc-copper couple was readily prepared in a few minutes, and the ethanol used in the reduction always formed an azeotrope with the hydrocarbons. Ethanol was completely removed from the azeotrope by shaking once with a large excess of water. The proportion of allene to acetylene hydrocarbon was about 90-95 per cent to 5-10 per cent indicated by i.r. and g.l.c. The acetylenic impurity was almost completely removed by treatment with aqueous ammoniacal silver nitrate solution. Any slight acetylenic impurity (1-2 per cent) was neglected as it is well known⁷⁹ that dihalocarbenes, under the conditions employed here add exclusively to the olefinic double bond (e.g. VoQuang and Cadiot⁸⁰ as well as Dyakonov and Danilkina⁸¹ showed that the addition of dihalocarbenes always occurs at the vinyl group rather than the acetylenic linkage irrespective of which occupies the terminal position), and the more volatile acetylene could easily be

removed during the distillation of the dihalomethylenecyclopropane. A 55-65 per cent over-all yield of allenes was obtained by this procedure.

Table I shows the allenes prepared by this procedure, together with their over-all yield and physical data:-

TABLE I

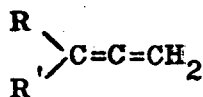

Allene

	Allene	b.p. °/mm.	Yield(%)	$\bar{\nu}_{\text{max}}$ cm^{-1}
1.	$\begin{array}{c} \text{Me} \\ \diagdown \\ \text{C}=\text{C}=\text{CH}_2 \\ \diagup \\ \text{Me} \end{array} \quad 82$	39-40	55	1950s, 850s
2.	$\begin{array}{c} \text{Et} \\ \diagdown \\ \text{C}=\text{C}=\text{CH}_2 \\ \diagup \\ \text{Me} \end{array} \quad 82$	72-74	65	1950s, 850s
3.	$\begin{array}{c} \text{Et} \\ \diagdown \\ \text{C}=\text{C}=\text{CH}_2 \\ \diagup \\ \text{Et} \end{array} \quad 82$	94	74	1950s, 850s
4.	$\begin{array}{c} \text{n-Pr} \\ \diagdown \\ \text{C}=\text{C}=\text{CH}_2 \\ \diagup \\ \text{H} \end{array} \quad 82$	72-74	52	1950s, 850s
5.	$\begin{array}{c} \text{n-Pent} \\ \diagdown \\ \text{C}=\text{C}=\text{CH}_2 \\ \diagup \\ \text{Me} \end{array}$	46-48/200mm.	57	1950s, 850s
6.	$\begin{array}{c} \text{t-Bu} \\ \diagdown \\ \text{C}=\text{C}=\text{CH}_2 \\ \diagup \\ \text{Me} \end{array}$	86-88	55	1950s, 850s

Preparation of Dihalomethylenecyclopropanes

Dihalocarbenes were generated by the method of Doering and Hoffmann i.e. from dry potassium t-butoxide in dry n-pentane and either chloroform or bromoform. Dichloro-

and dibromomethylenecyclopropanes (see Table II) were obtained in 40-70 per cent yield and identified by i.r., u.v., n.m.r., g.l.c., ozonolysis, elemental analysis and hydrogenation.

TABLE II

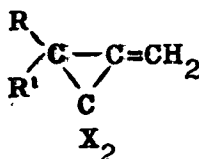

Dihalomethylenecyclopropane

	R	R'	X	b.p. °/mm.	Yield %	$\nu_{\text{max}} \text{ cm}^{-1}$	$\lambda_{\text{max}} \text{ m}\mu (\xi)$
1	Me	Me	Cl	65-66/80	49	1820w, 1730w, 910s, 865s	204 (5,200), sh. 234 (500)
2	Me	Me	Br	66-68/20	68	1820w, 1750w, 1040m, 905s, 800s	206 (5,250), sh. 225 (3,000)
3	Et	Me	Cl	70/90	50	1820w, 1730w, 1002m, 910s, 865s	206 (5,250), sh. 234 (500)
4	Et	Me	Br	49-50/2	58	1820w, 1750w, 1040m, 905s, 800s	207 (5,300) sh. 225 (3,000)
5	Et	Et	Cl	62-64/70	54	1820w, 1720w, 1002m, 910s, 865s	
6	Et	Et	Br	64-65/3	73	1820w, 1750w, 1060m, 905s, 800s	210 (5,760)
7	n-Pr	H	Cl	66-68/100	47	1820w, 1720w, 1038m, 912s,	
8	n-Pent	Me	Cl	64-65/70	36	1820w, 1730w, 1012m, 910s, 865s	
9	t-Bu	Me	Cl	78-80/65	51	1820w, 1750w, 1010m, 910s, 865s	

It was found that both the dichloro- and dibromo-carbenes added exclusively to the alkyl-substituted double bond of the allene. This result was confirmed by the following evidence:-

G.l.c. in each case gave a single component for the distilled adduct. Elemental analysis for carbon, hydrogen and chlorine or bromine agreed with the molecular formula. The i.r. spectra of dichloromethylenecyclopropane showed strong bands at 865 and 910 cm.^{-1} with overtones at 1730 and 1820 cm.^{-1} , whereas dibromomethylenecyclopropanes showed maxima at 800, 905 (>C=CH deformations), 1750 and 1810 (overtones) cm.^{-1} . All the cyclopropanes showed a band at 1000-1070 cm.^{-1} which may be ascribed to the cyclopropane skeletal vibrations. The u.v. absorption spectra showed maxima at λ_{max} 205-207 $\text{m}\mu$ ($\xi, 5,200-5,300$) and shoulders at 225 $\text{m}\mu$ ($\xi, 500 \text{ m}\mu$ for dichloro- and 3000 $\text{m}\mu$ for dibromomethylenecyclopropanes). In the case of dibromomethylenecyclopropanes these shoulders which increase with increased methyl substitution suggest non-bonded interaction of the bromine atoms with the π -orbital of the allene system.

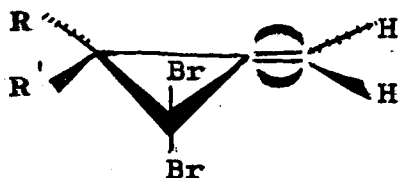

This result is similar to that of dialkyl-substituted allene bromides⁸³ which show a shoulder or maximum at 217-227 μ and the intensity of this band also increased with increased alkyl substitution, while the chloro-allenes did not show absorption above 205 μ .

N.m.r. spectroscopy showed two non-equivalent protons for the exocyclic methylene group at τ 4.1 and 4.5.

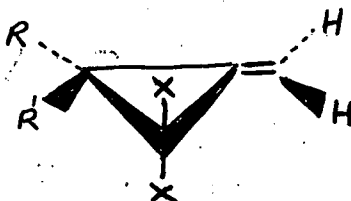

Ozonolysis gave formaldehyde identified by its dimedone derivative from its melting point and mixed melting point of an authentic sample, thus confirming the exocyclic methylene group.

On hydrogenation, 1,1-dichloro-2,2-dimethyl-3-methylene-cyclopropane absorbed one molar equivalent of hydrogen. As a further check, 1,1-dichloro-2,2,3-trimethylcyclopropane was synthesised from 2-methyl-but-2-ene and dichlorocarbene¹⁴ and its i.r. spectrum compared with that of the hydrogenated sample of (II, R=R'=Me) and found to be superimposable. G.l.c. also confirmed the identity of the two products.

It is interesting to note that 1-bromo-3,3-dialkyl allenes seem to be inert to attack by dihalocarbenes despite the fact that inductive electron withdrawal by the bromine from the alkyl-substituted double bond must be very weak.

As 1-bromoallenes form allenic carbenes⁸⁴ by 1,1-elimination, the usual experimental procedure was modified, and a mixture of bromoallene and bromoform or chloroform was added to the solid potassium t-butoxide suspension in dry pentane.

The recovery of bromoallene in almost quantitative yield confirmed by g.l.c., i.r., and its boiling point, indicated that (a) dihalocarbenes were formed in preference to allene carbenes, and (b) dihalocarbenes did not add on to either of the allene double bonds.

Varying the reaction conditions, e.g. adding haloform to a mixture of potassium t-butoxide, pentane and allene bromide and varying the time, temperature and rate of stirring, gave no addition products. When the allene bromide was reacted with sodium trichloroacetate in dry dimethoxy-ethane following Wagner's method⁶ no cyclopropane was produced.

Finally, following Seyferth's suggestion¹⁰ that

dihalocarbenes generated from trihalomethyl-phenyl-mercury were more reactive as they contained extra thermal energy, 1-bromo-3-methyl-penta-1,2-diene was reacted with tribromomethyl-phenyl-mercury in dry benzene for 3 hr. under reflux. Again no addition took place although dibromocarbenes were produced as shown by the presence of phenyl-mercury-bromide at the end of the experiment. This established the complete inertness of 1-bromo allenes towards dihalocarbenes, and supported the explanation that their inertness was due to the non-bonded interaction of the π -electrons of bromine atoms with those of the allene system. Seyferth's success in preparing the dichloro adduct from tetrachloroethylene may be due to the fact that there is in this case no such non-bonded interaction but simply conjugation of the p-electrons of C and Cl.

Cumulenes from Dihalo-methylenecyclopropanes

The following cumulenes (II) were prepared by the treatment of dichloro- and dibromo-methylenecyclopropanes (I) and n-butyl-lithium in ether at temperatures between -40° and -30° :-

TABLE I

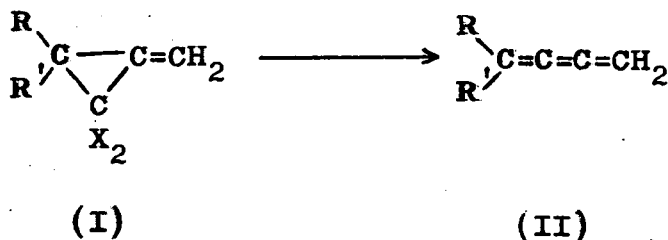

	R	R'	X	b.p. ^o of II/ether azeotrope	Ratio of (II):ether (%)	Yield of (II) (%)
1	Me	Me	Cl	56-58 ^o	50-50	70
	Me	Me	Br	56-58	50-50	75
2	Me	Et	Cl	65-68	60-40	73
	Me	Et	Br	65-68	65-35	75
3	Et	Et	Cl	76-80	50-50	73
	Et	Et	Br	76-80	50-50	80

The general procedure was as follows:-

n-Butyl-lithium was prepared in dry ether at $-10-0^{\circ}$ and cooled to -40° - -30° in a Dewar flask. A solution of dichloro- or dibromomethylenecyclopropane (I) in ether precooled to -30° was added in one portion and the mixture stirred vigorously on a magnetic stirrer for 30 min. at -30° . Alternatively the dihalide solution at room temperature was added to the n-butyl-lithium solution at $-40- -30^{\circ}$. The mixture was finally allowed to warm up to room temperature slowly (ca. 30 min.), distilled in vacuo and the volatile materials collected in a trap precooled at -40° . The trapped liquid was finally re-distilled under nitrogen at atmospheric pressure to give cumulene (II).

I.r., u.v., and g.l.c., were carried out immediately and a weighed sample hydrogenated using platinum black.

All the cumulenes showed a sharp band in the i.r. at $\bar{\nu}_{\max}$ 2080-2090 ($C=C=C=C$) $cm.^{-1}$, and u.v. absorption at λ_{\max} 218-220 $m\mu$ (ξ , 3500-7700), 254-256 $m\mu$ (ξ , 13000-16000) and 294 sh. (ξ , 700-900) (See Table II).

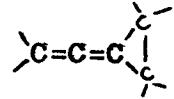
The absorption maximum of 2080 $cm.^{-1}$ is reminiscent of the allenic cyclopropyl system⁸⁴, >C=C=C  which has $\bar{\nu}_{\max}$ 2020 $cm.^{-1}$. This value is also close to that

reported for cumulene aldehyde⁴¹ at 2066 cm.⁻¹ and is ascribed to the rigid cumulene system.

The u.v. absorption maxima of the cumulenes gave the expected bathochromic shift for increased methyl substitution.

Hydrogenation of cumulene (II, R=R'=Me) and cumulene (II, R=Me, R'=Et) gave 2-methylpentane and 3-methylhexane respectively, identified by g.l.c. using authentic samples of these paraffins.

TABLE II

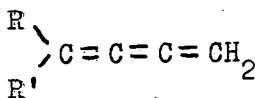

Cumulene

	R	R'	ν_{\max} cm. ⁻¹	λ_{\max} m μ (ϵ)
1.	Me	Me	2060m, 1650w, 1258s, 1230s, 840b	220(3500), 254(13000), 294sh.(700)
2.	Me	Et	2080m, 1650w, 1260s, 1220s, 840b	218(7750), 256(16200), 294sh.(910)
3.	Et	Et	2060m, 1625w, 1260s, 1220s, 840b	218(7700), 256(16000), 294sh.(900)

All the four cumulenes were extremely sensitive to oxygen and rapidly turned yellow on exposure to air, and therefore complete separation from ether and isolation by preparative g.l.c. was found to be impracticable. On keeping overnight at room temperature, solution of cumulenes in ether or alcohol gave a heavy white precipitate, probably polymeric in nature. The polymer was high melting ($>300^{\circ}$) and insoluble in all the usual solvents. Skattebøl³² reacted 1,1,3,3-tetramethylallene with dihalocarbene and converted the resulting dihalocyclopropane into the cumulene, 2,5-dimethyl-2,3,4-hexatriene, with properties similar to those of the cumulenes described in this thesis. It is interesting to note that the C-C stretching band near 2080 cm.^{-1} was absent, possibly due to the symmetrical structure of the tetramethyl cumulene.

Hexa-1,2,3-triene, the cumulene obtained from 1,1-dibromo-2-n-propyl-3-methylene-cyclopropane, polymerised instantly to a white, insoluble solid and could not be isolated. Skattebøl³² has proposed a structure for the polymer obtained from 2,5-dimethyl hexa-2,3,4-triene mainly on i.r.evidence $\sqrt{\text{two bands at } 1355 \text{ and } 1320\text{ cm.}^{-1}}$ for gem-dimethyl, 1625w (C=C) and 1142s (C-O

stretching) 7 cm.^{-1}

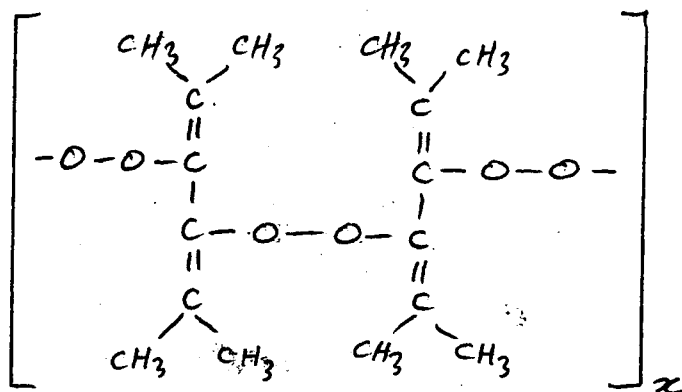

Analogous planar structures may be put forward for the polymers from the cumulenes with terminal methylene group as follows:-

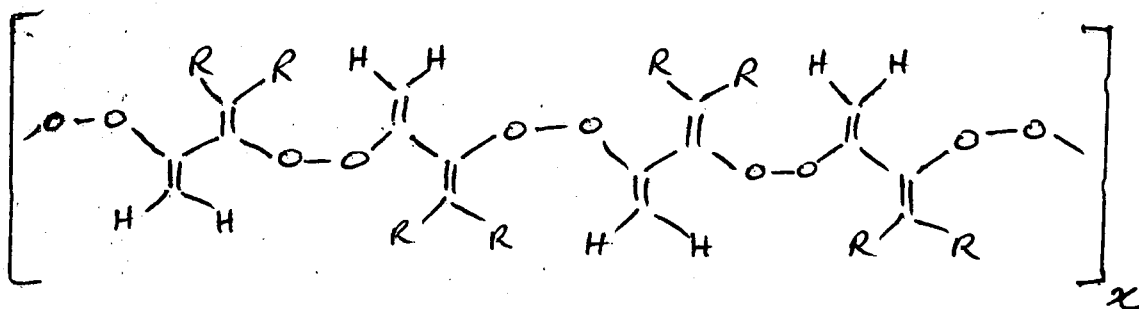
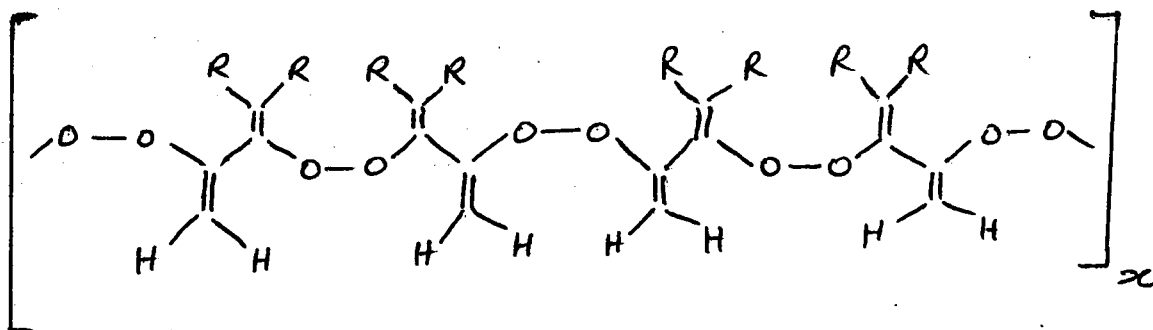

Cope Rearrangement of Propargyl Alkenyl Malonates

The work of Cope, Hofmann and Hardy⁴⁴ established that allyl alkenyl malonates (I, X=Y=COOEt), cyanoesters (I, X=CN, Y=COOEt) and malononitriles (I, X=Y=CN) undergo a thermally induced intramolecular rearrangement to give allyl alkylidenemalonates (II, X=Y=COOEt), -cyanoesters (II, X=CN, Y=COOEt) and -malononitriles (II, X=Y=CN) respectively. This reaction in a generalised form is now known as "Cope rearrangement".

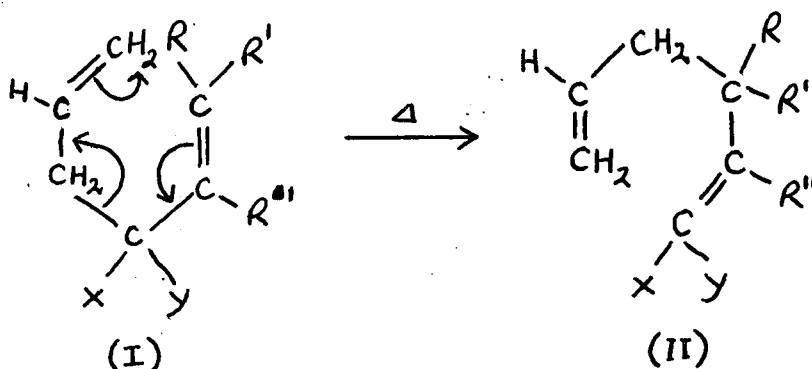

Black and Landor⁸⁵ have shown that propargyl alkenyl ethers (III) undergo thermally induced Claisen rearrangement to give allenic aldehydes (IV):-

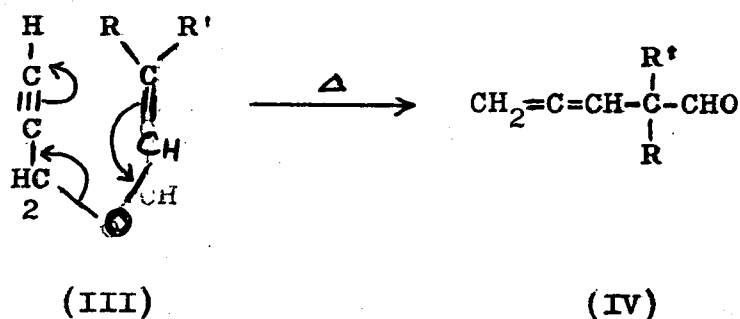

It therefore seemed plausible that propargyl alkenyl-malonates (V) should also undergo a Cope rearrangement to give allenic alkylidene-malonates (VI):-

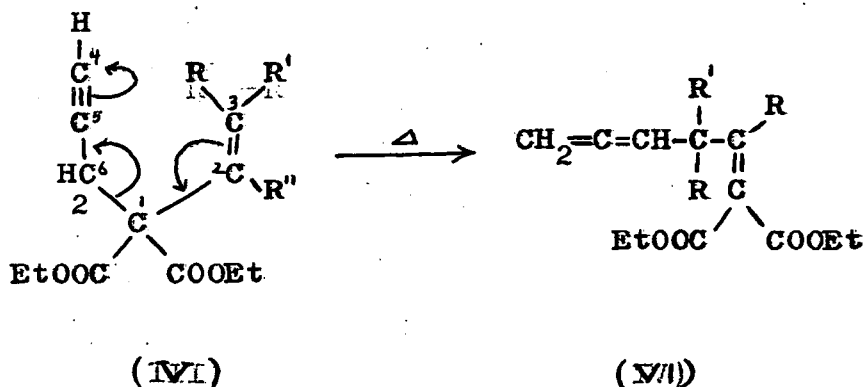

This was found to be the case under carefully controlled conditions.

Kinetic studies by Cope, Hoyle and Heyl⁸⁶ demonstrated that the reaction was first order suggesting an intramolecular rearrangement and also that the rate of reaction was proportional to the electronegativity of the groups X and Y (I) e.g. the rate increases in the order X and/or Y=CN > COOEt > Ph >> Me. It was suggested that electron-attracting groups at X and Y increase the rate of reaction by virtue of their attraction for the electron-pair between carbon atoms 1 and 6 which lowers the dissociation energy at this bond⁴⁷.

Hence one of the motivating forces responsible for this rearrangement is the unequal sharing of the electron pair binding the allyl group to the carbon atom 1 so that in the isomerisation, the allyl group becomes detached from this atom and recombines with carbon atom 3 which is less electron-attracting. It was evident that the influence causing the detachment of the allyl group is the electron attraction of carbon atom 1 and the tendency to form a stable conjugated system.

Black and Landor's⁸⁵ results showed that substituted propargyl alkenyl ethers e.g. (III, R=R'=Me) rearrange at lower temperatures and give a much higher yield (70 per cent) than the unsubstituted propargyl vinyl ether (III, R=R'=H, 20-30 per cent). This was interpreted as favouring a homolytic rather than a heterolytic mechanism, i.e. it did not favour a two-electron shift (III→IV) but was best explained by a one-electron shift (VII→VIII).

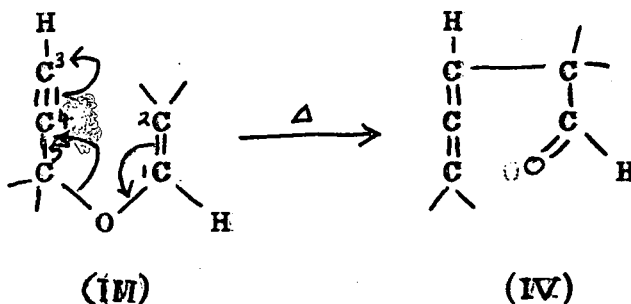

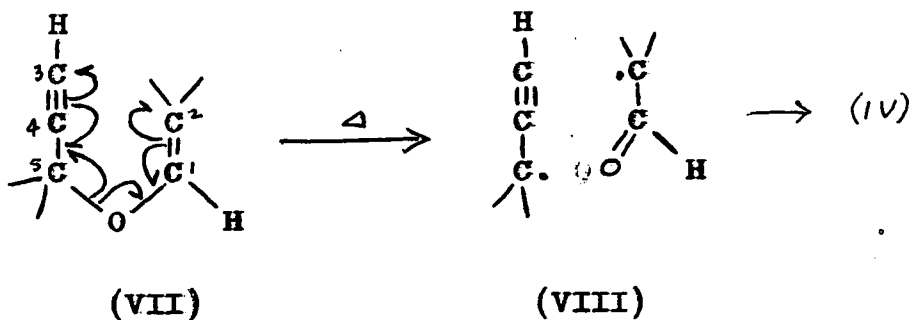

The work described in this thesis was based on the above considerations. Thus diethyl malonates were used throughout (except in one case, the attempted rearrangement of hex-1-en-5-yne) and a series of compounds with alkyl groups at different sites was studied with a view to elucidating the effect of alkyl groups on this rearrangement. Also, the optimum conditions for the Cope rearrangement of propargyl alkenyl malonates were investigated by varying time and temperature.

The malonates used for this investigation were prepared by the following two-step reaction:-

(a) Preparation of alkylidene malonates involving the base catalysed condensation of diethyl malonate with aldehydes and ketones.⁸⁷ Volatile aldehydes and all ketones were mixed with acetic anhydride, diethyl malonate and freshly fused zinc chloride and heated at 100-150° for 24 hr. and then distilled. The non-volatile aldehydes

were reacted with diethyl malonate in the presence of dry benzene in the Dean and Stark apparatus until the theoretical volume of water had been removed from the reaction mixture (2-3 hr.). The use of catalytic quantity of piperidyl acetate was found to give the most satisfactory result. Ammonium acetate which give good yields⁸⁸ of cyanoacetates from sterically hindered ketones gave poor yields of the corresponding malonates.

(b) The alkyldene malonates on treatment with propargyl bromide gave propargyl alkenyl malonates (X) in good yield (60-70 per cent). Cope and Hancock⁸⁸ reported that the use of sodium ethoxide with alkyl and allyl halides generally gave poor yields owing to alcoholysis. A number of experiments in this laboratory have shown that the use of low reaction temperatures (0-20°) and long reaction times (12-24 hr.) resulted in a considerable improvement in yield and purity of the propargylated product.

The above reactions may be summarised as follows:-

of an allene band at ν_{\max} 1950 and of the (α, β -unsaturated) ~~C=C~~ band at 1650 cm^{-1} as well as the decrease in intensity of the terminal acetylenic band at 3300 cm^{-1} indicated that the rearrangement had taken place. After a certain time there was no significant change in the i.r. spectrum. Further heating caused both the allene and the acetylene bands to diminish. It was found impracticable to employ an inert nonvolatile solvent as the only suitable solvent available, i.e. silicone oil, had i.r. absorption in the ν_{\max} 1900-2000 cm^{-1} region, making it difficult to ascertain the progress of the rearrangement based on the appearance and enhancement of the allene band in the same region.

The products could be separated into three isolable fractions: (a) the starting propargyl ~~alkenyl~~ malonate; (b) the required allenic alkylidene malonate; and (c) the alkylidene malonate from which the propargyl ~~alkenyl~~ malonate had been prepared. It was observed that whenever the rearrangement was incomplete, (a) was the largest fraction, (b) the smaller, and there was no (c). When the optimum conditions were attained, (b) was the largest fraction, and (a) and (c) were present only in small amounts. Continued heating gave increasing amount of (c) and

polymeric material, and decreasing amounts of (a) and (b). These ratios were determined by g.l.c. areas and i.v. spectra.

Optimum conditions varied somewhat with different propargyl alkenylmalonates, but were generally achieved at the temperature range of 270-280° and reaction times of 10-20 min. The following sequence of reactions takes place:-

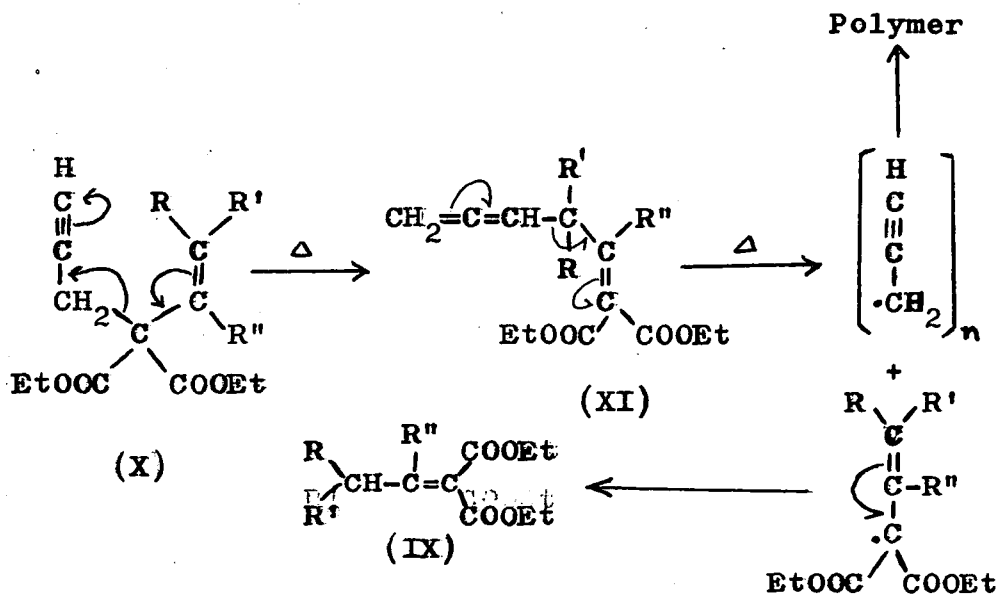

Separation of the allenic malonate from the propargyl alkenylmalonate and alkydene malonate was achieved by first of all distilling and completely removing the lower boiling alkydene malonate, and then by one of the following two methods:-

(i) Redistillation of the higher boiling fraction using a short (6") Fenski column. This method produced pure allenic alkyldenemalonates in 25-35 per cent yield.

(ii) Shaking the higher boiling fraction with aqueous ammoniacal silver nitrate solution to remove the malonate containing the terminal acetylene. Addition of a few drops of ethanol helped to break the rigid boundary separating the oily malonate from the aqueous solution. This method generally required prolonged agitation (3-4 hr.) for complete separation.

Small amounts of the pure allenic alkyldenemalonate were also obtained by preparative g.l.c. using 10 per cent silicone oil on celite packed in a 6 ft. Pyrex column of 1" diameter and passing nitrogen through it.

The purity of the allenic alkyldenemalonate (XI) was determined by g.l.c. (which gave a single component in each case), correct elemental analyses, i.r. bands at $\bar{\nu}_{\max}$ 1950 m (C=C=C), 1740s ($\bar{\nu}$ C=O), 1650 m (α,β -unsaturated C=C) and 860 b (C=C=CH₂) cm.⁻¹, and a u.v. maximum at λ_{\max} 204-210 m μ (ξ , 8000-15500) due to the C=C bond in conjugation with the C=O bonds of the malonate group.

The unequivocal assignment of structure to the allenic alkyldenemalonates cannot be achieved by i.r., g.l.c. and

elemental analyses alone as an alternative structure containing the allenic group could be formed theoretically by prototropic rearrangement of the propargyl group, i.e. without a Cope rearrangement. Such a structure would give a similar i.v. spectrum and elemental analyses. U.V. spectra, however, are the only reliable criteria, since the allene from the Cope rearrangement (XI) is conjugated enedioate whereas allene (XII) from the prototropic rearrangement is not.

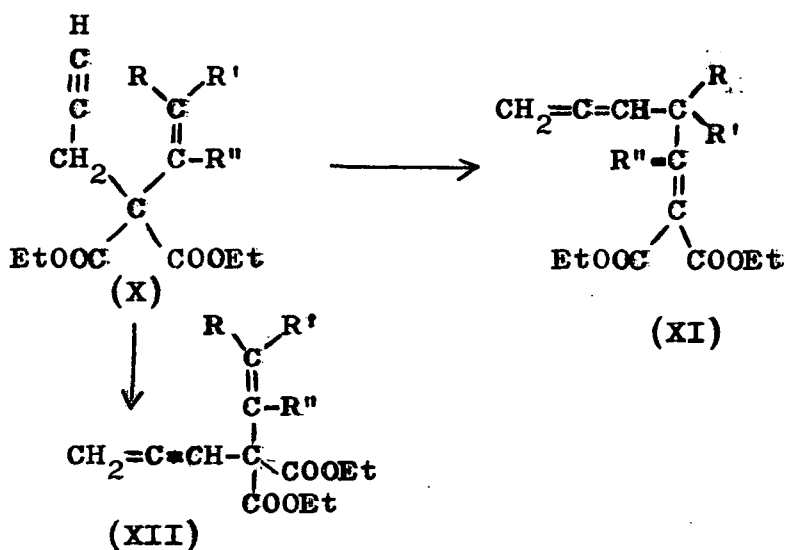

N.m.r. spectra are of little help in distinguishing (XI) and (XII).

Chemical evidence which confirmed the structure as (XI) was obtained by two different routes as follows:-

(i) The allenic alkylidenemalonate (XI, R=Et, R=R'=H) was catalytically hydrogenated to give diethyl 3-ethyl-hexa-1,1-dicarboxylate (XIII). Allyl n-butenyl malonate (I, X=Y=COOEt, R=Et, R=R''=H) was prepared according to the procedure of Cope, Hoyle and Heyl⁸⁶, and was rearranged to yield diethyl 3-ethyl-hexa-1,5-diene-1,1-dicarboxylate (II, X=Y=COOEt, R=Et, R=R''=H). The latter was catalytically hydrogenated to yield diethyl 3-ethyl-hexa-1,1-dicarboxylate (XIII), found to be identical (boiling point, i.v. spectra and g.l.c.) with the hydrogenated sample obtained from (XI, R=Et, R=R''=H). The barbituric acid of the saturated malonates from both routes gave the correct melting points and mixed melting points.

It was therefore shown that a Cope rearrangement had taken place and that the rearranged product had structure (XI, R=Et, R=R'=H):-

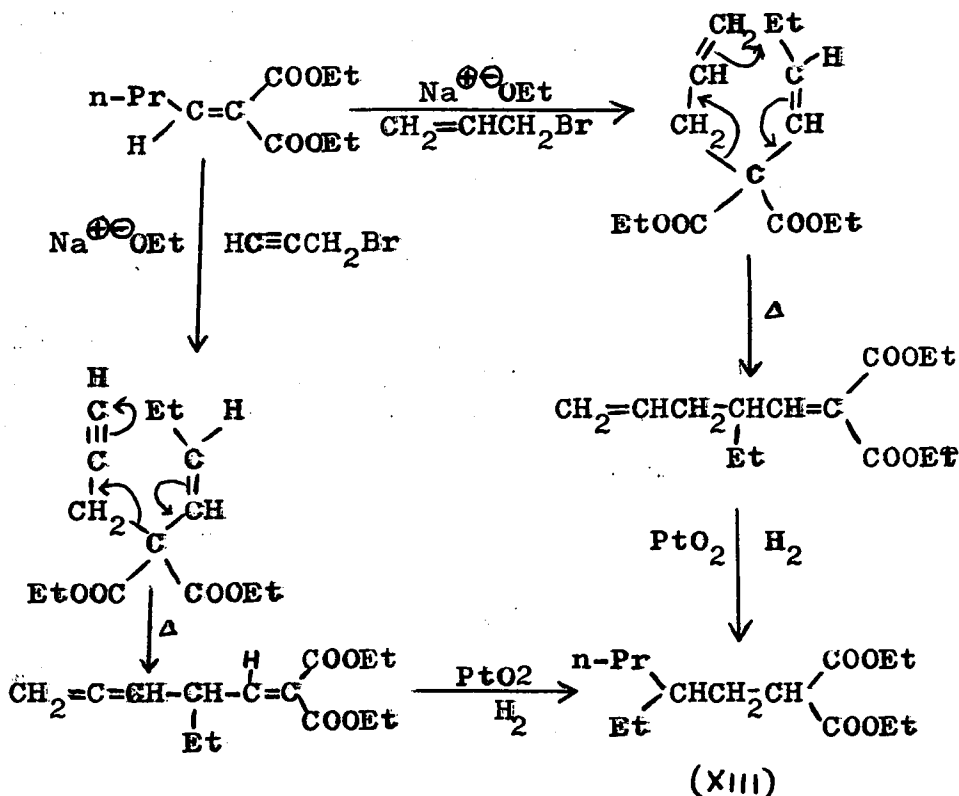

An independent synthesis of the Cope rearrangement product (XIV) was achieved as follows:-

(ii) 2,2-Dimethyl-penta-3,4-diene-1-al (IV, R=R'=Me) was prepared by the method of Black and Landor⁸⁵ as follows:-

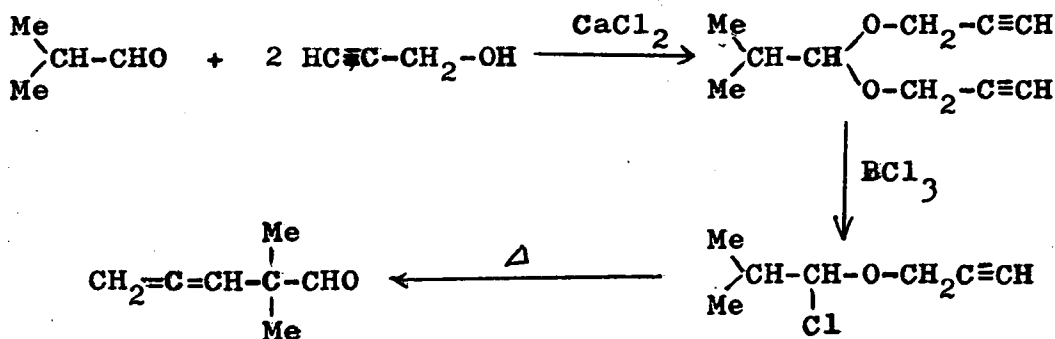

The allenic aldehyde (IV, R=R'=Me) was then condensed with diethyl malonate by the method of Cope and Hancock⁸⁸, using a Dean and Stark apparatus, benzene and piperidyl acetate to give diethyl 3,3-dimethyl-hexa-1,4,5-triene-1,1-dicarboxylate (XI, R=R'=Me, R=H) in 15 per cent yield.

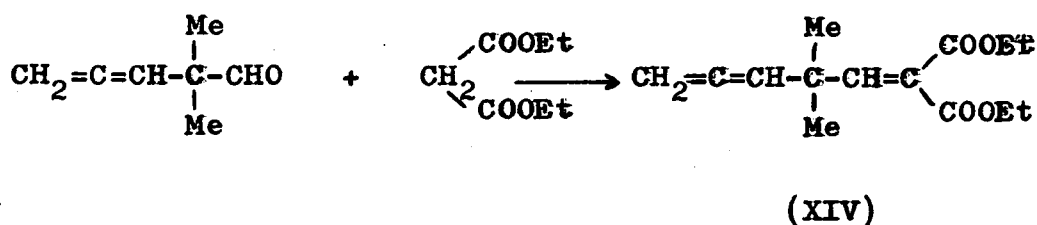

Steric hindrance due to the α -methyl groups of the aldehyde probably inhibits the condensation thus resulting in the poor yield of the allenic alkylidene malonate (XIV). However, the product was identical with the allenic alkylidene malonate obtained from the Cope rearrangement of propargyl isobutenyl malonate (X, R=R'=Me, R=H), the identification being carried out by i.r. and u.v. spectra, and g.l.c.

Hence the occurrence of thermally induced intramolecular Cope rearrangement of propargyl alkenyl malonates was unequivocally established.

The rearrangement of the propargyl alkenyl malonates (X) investigated here are shown in the following Table incorporating the yields and the reaction conditions:-

TABLE I

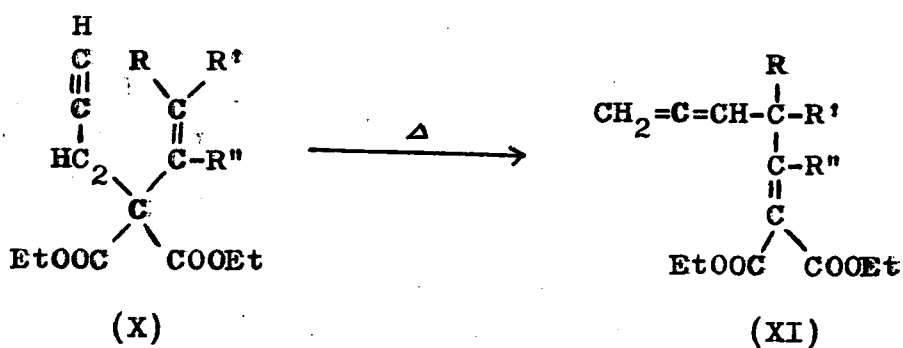

	R	R'	R''	Yield (%) of (XI)	Reaction Temperature Range ($^{\circ}\text{C}$)	Reaction Pressure (mm.)	Reaction Time (min.)	$\lambda_{\text{max}}^{\text{max}} \mu (\xi)$ of (XI)
1	H	H	H	---	200-220	20-744	90	---
					220-270	744	90	
					270-280	744	90	
					280-400	744	15	
2	Me	H	H	---	200-220	20-744	90	---
					220-270	744	90	
					270-280	744	90	
					280-400	744	15	
3	Et	H	H	29	270-280	744	15	206(10,790)
4	H	H	Me	39	270-280	744	15	210(10,101)
5	Me	H	Me	33	270-280	744	10	208(8,988)
6	Me	Me	H	35	270-280	744	20	204(12,513)

It will be seen that four of the six compounds studied underwent Cope rearrangement at 270-280° at atmospheric pressure and 10-20 min. In each case further heating did not increase the amount of allene formed. Moreover, heating the pure allene did not give the acetylenic starting material (i.e. examination), hence the rearrangement does not appear to be a reversible one and the amount of allene formed does not appear to be limited by the position of the equilibrium. Further heating of the reaction mixture, however, caused darkening of the product, diminution of the allehe band at 1950⁻¹ cm. and regeneration of the original alkylidene malonate. This general tendency indicates that the activation energy for rearrangement is only marginally lower than the energy required for fragmentation. Yields of allenic compounds were never in excess of 39 per cent even with very careful control of the reaction conditions.

According to the transition state theory

$$k = \frac{BTe^{\Delta S/R} \cdot e^{-\Delta E/RT}}{h} \dots \dots (i)$$

where k = first order reaction rate constant

B = Boltzmann constant = 1.3805×10^{-16} erg/°A

T = absolute temperature, °A. (273.15 + °C).

h = Planck constant = 6.624×10^{-27} erg.sec.

ΔS = difference in entropy between initial and activated states in entropy units.

ΔE = experimental activation energies, calories

R = 1.987 cal. / $^{\circ}$ A.

and $k = p e^{-\Delta E/RT}$ (ii)

where p = frequency factor,

Therefore $\ln k =$

$$\ln k = - (\Delta E/R) \cdot \frac{1}{T} + \ln p \dots \dots (iii)$$

Foster, Cope and Daniel⁴³ plotted the graph of the logarithm of the per cent of unreacted reactant (x) against the time (t) in minutes and obtained the value of k from the slope:-

$$k = \frac{-\ln x}{t}$$

$$= \frac{-2.303 \cdot (\text{slope})}{60}$$

Fitting this value of k in equation (iii) and plotting the graph of $\ln k$ against absolute temperature, they calculated the value of ΔE from the slope.

From equations (i) and (ii)

$$p = \frac{BT \cdot e}{h} \frac{\Delta S}{R}$$

$$\Delta S = R \ln p - R \ln \left(\frac{BT}{h} \right)$$

Hence they calculated the values of ΔS .

In order to determine what part of the difference in rearrangement rates of allyl alkenyl malonates was due to differences in energies of activation (ΔE) and what part was due to difference in entropies of activation (ΔS), incremental values of $T \Delta S$ and ΔE were calculated, and it was found that approximately 60 per cent of the differences in rearrangement rates is due to differences in ΔE and the other 40 per cent due to differences in ΔS .

Furthermore the large decrease in entropy (11-14 e.u.) of activation of these rearrangements indicated that several degrees of freedom may be restricted in the activated complex as would be expected for the formation of a cyclic transition state.

These results of Foster, Cope and Daniels would also suggest a cyclic transition state for the Cope rearrangement of acetylenic to allenic compounds, but such a cyclic transition state (XV) would be very much less stable with the linear acetylene-allene system than it is with the

flexible allyl system. Both ΔE and ΔS would be expected to be larger for the acetylene-allene rearrangement.

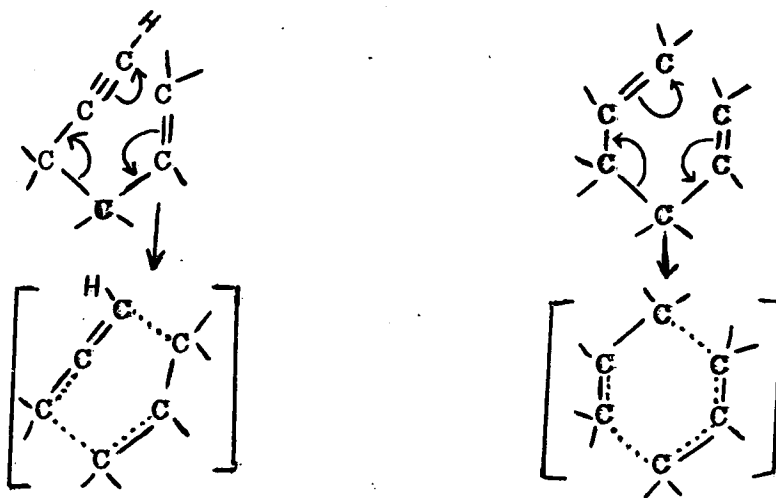

(XV)

This is borne out by the higher temperatures ($270-280^{\circ}$) required for the rearrangement investigated here as compared with those reported by Cope and his coworkers ($150-200^{\circ}$).

Furthermore, increased substitution leads to an easier rearrangement as indicated by the yields (see Table I), showing that steric hindrance in the transition state is not an important factor. Compound (2) does not fit in with this theory of the stability of the product. Again, a homolytic mechanism is indicated (as in the

Claisen rearrangement of propargyl alkenyl ethers⁸⁵), but an additional factor may be the stability of the product, the alkylidene malonate which gains stability with increasing alkyl substitution on carbon atoms 2 and 3 of the malonates.

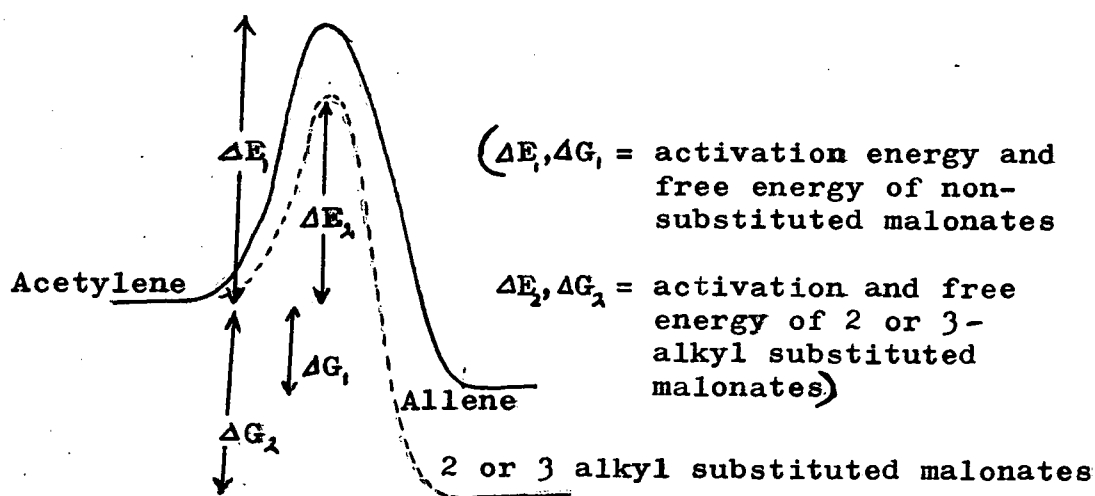

Levy and Cope⁴⁵ showed that 3-phenyl-hexa-1,5-diene rearranged smoothly at 170° to 1-phenyl-hexa-1,5-diene in 70 per cent yield, whereas 3-methyl-hexa-1,5-diene underwent only partial rearrangement after prolonged heating at 300° for 24 hr. The success of the former rearrangement may be attributed to the lowering of energy of the transition state and of the product due to the formation of a conjugated system.

Two compounds (Table I, 1. and 2.) did not rearrange under the usual experimental condition and these were more exhaustively studied.

A temperature range of 200-400^o, pressure range of 20-744 mm. and times up to 90 min. were explored without success; allenic compound could not be detected in the product. Black and Landor's procedure⁸⁵, involving the use of a column tightly-packed with glass-wool and electrically heated did not give rearrangement product at temperatures of 200-400^o. At temperatures below 300^o the acetylenic starting material was recovered, while at temperatures in excess of 300^o fission products were obtained. Thus diethyl propargyl vinylmalonate gave only diethyl ethylidenemalonate and diethyl propargyl propenylmalonate gave diethyl propylidenemalonate (both identified on g.l.c.) and polymeric material. It is not known whether diethyl allyl vinylmalonate rearranges under similar conditions to yield the expected product diethyl hexa-1,5-diene-1,1-dicarboxylate but diethyl allyl propenylmalonate rearranges to diethyl 3-methyl-hexa-1,5-diene-1,1-dicarboxylate in 68 per cent yield.⁴⁴

These results show that fission is energetically more favourable than rearrangement for propargyl vinyl- and propenyl-malonate, but the reverse is true for allyl

propenyl malonate.

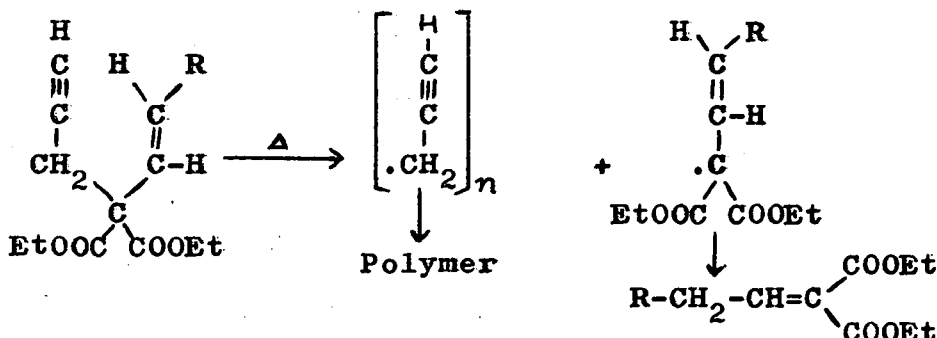

Levy and Cope⁴⁵ have reported that hepta-2,6-diene underwent reversible Cope rearrangement after 24 hrs. at 300° to yield 20-30 per cent 3-methyl-hexa-1,5-diene. If a similar rearrangement were possible in the case of a hex-1-en-5-yne system an allenic hydrocarbon would be obtained. To investigate this rearrangement hex-1-en-5-yne (XVI) was prepared from allyl magnesium bromide in ether and propargyl bromide in 50 per cent yield. There seemed to be no advantage in using tetrahydrofuran as solvent and a copper catalyst as suggested by Sarratosa⁸⁹, and normal condition (temperature of 0-20°) was used.

The en-yne hydrocarbon was identified by its i.r. spectra ($\bar{\nu}_{\text{max}}$ 3300s, 2120w (C≡CH), 1650m (C=C) and 910s (C=CH₂) cm.⁻¹ and by its g.l.c. which showed a single component.

The hexenyne did not rearrange when passed through a Pyrex column tightly packed with glass-wool at temperatures between 200-400° with a contact time of 1-5 min. The product was collected in a cold trap at -60° and was shown to be the original en-yne by i.r. spectroscopy.

A sample of the en-yne was heated in a Carius tube containing nitrogen at 300° for 24 hr. The liquid product was dark and partly polymeric (indicating that some fission had occurred? and contained largely the starting en-yne hydrocarbon (XII). At temperatures in excess of 300° the amount of polymeric material increased rapidly and that of the en-yne diminished. No allenic material was isolated.

Hence both types of propargyl vinyl compounds, i.e. malonate and unsubstituted hydrocarbon, did not give an allenic product from Cope rearrangement. This result further strengthens the importance attached to the alkyl substituents in the 3 position for this rearrangement.

Cyclopropane Esters from the reaction of Dimethylsulphoxonium Methylide and α,β -unsaturated Esters

A preliminary publication by Corey and Chaykovski⁵² showed that dimethylsulphoxonium methylide (I) in dimethyl sulphoxide as solvent may be used to convert saturated ketones (II) to oxyranes (III) and α,β -unsaturated ketones (IV) to cyclopropyl ketones (V):-

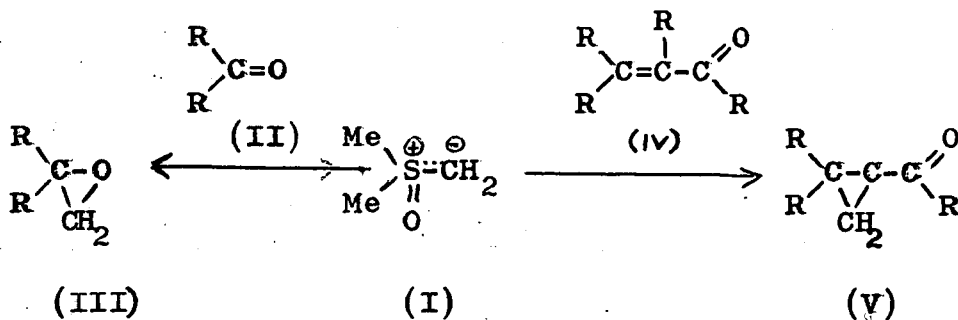

These authors also showed that dimethylsulphonium methylide (VI) converted both the saturated ketones (II) and unsaturated ketones (IV) to the oxyranes (III) and (VII) respectively. The methylide (VI) in large excess was also able to convert 1,1-diphenylethylene (VIII) to 1,1-diphenylcyclopropane (IX):-

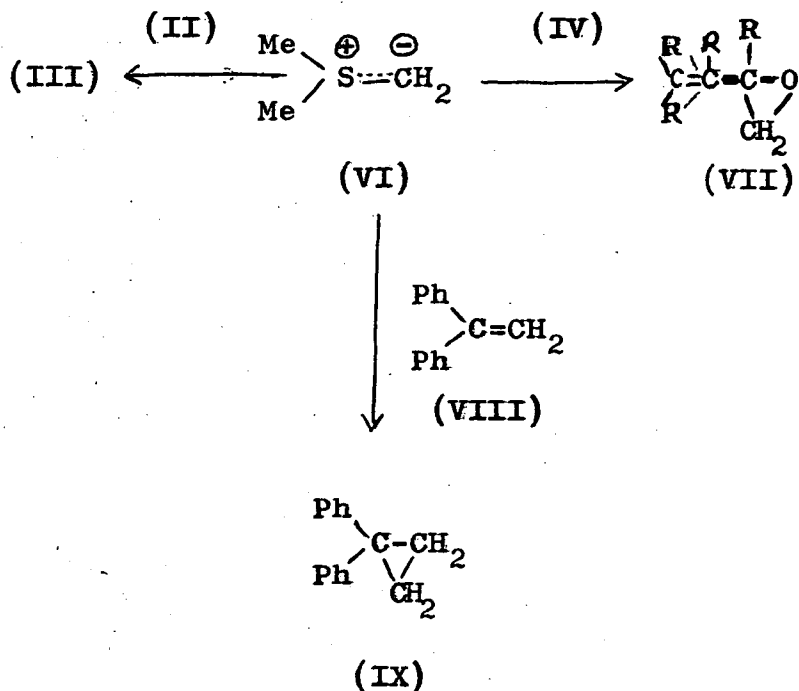

The sulfoxonium methylide (I) therefore provides a selective method for converting the saturated ketones to oxiranes while the sulphonium methylide (VI) provides a general method for converting all types of ketones to their corresponding oxirane derivatives.

Investigations in this laboratory of the preparation of cyclopropanes, especially the naturally occurring Hypoglycine A⁹¹ and its lower homologue, by the Simmons-Smith method^{92,93} showed that the Simmons-Smith method is not particularly successful with conjugated esters,

and this may be explained by postulating that the electrophilic Simmons-Smith reagent (X) will not easily add to a deactivated olefinic double bond.

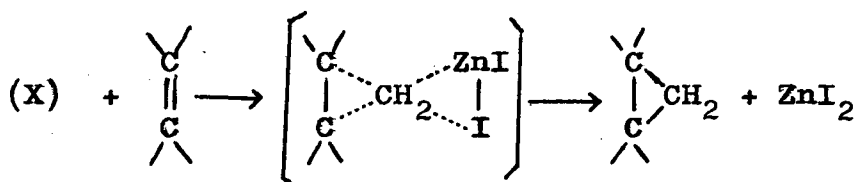
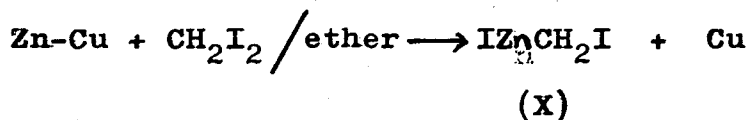

Corey and Chaykovski's method on the other hand involves the nucleophilic reagent (I) which would attack an electropositive centre (Recently the preparation of a more active Simmons-Smith reagent has been reported⁹⁴ which is supposed to add to α, β -unsaturated ketones and esters⁹⁵. This, however, has not been confirmed⁹⁶). The application of the two methods to the formation of cyclopropanes from dienates should give complementary results, i.e. the dienate of structure (XI) would be expected to yield the α, β -methylene adduct (XII) by Corey and Chaykovski's method and the γ, δ -methylene adduct (XIII) by the Simmons-Smith method.

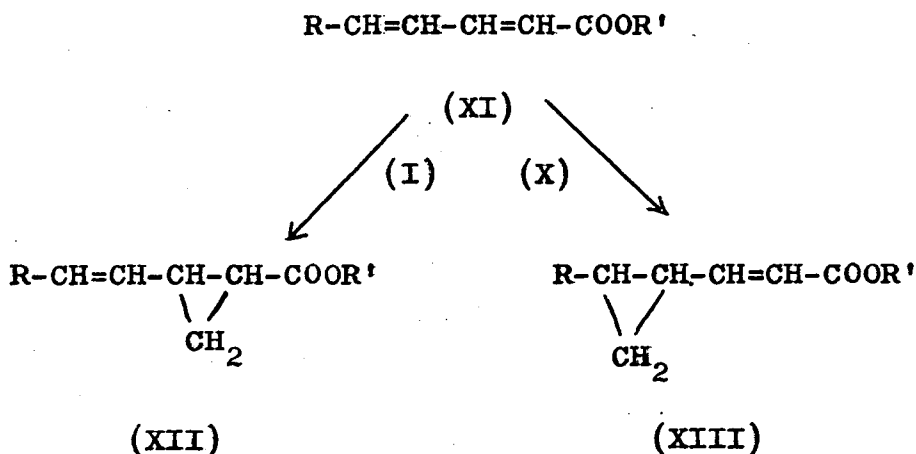

In 1964, Bagley, Smith and Wolff⁶⁵ reported the isolation of the ester of a naturally occurring, allenic cyclopropanecarboxylic acid, which they named "Laballenic acid". They produced evidence to show that this compound was 2,3-methylene-heptadeca-4,5-dienoic acid (XIV, R=CH₃(CH₂)₁₀, R'=H)

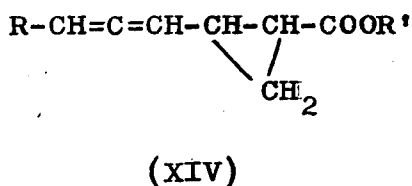

Shortly after the publication of this compound appeared, our investigation of the synthesis of such compounds was initiated. Since dihalocarbenes are known to be electrophiles, they would be expected to attack the

dienoate (XI) in the γ, δ -position to give the dihalo-cyclopropane (XV). Hence work was started on the following scheme for the preparation of ethyl 2,3-methylene-hepta-4,5-dienoate (XIV, R=Me, R'=Et) as a preliminary experiment for the synthesis of 2,3-methylene-heptadeca-4,5-dienoic acid (XIV, R=CH₃(CH₂)₁₀, R'=H):-

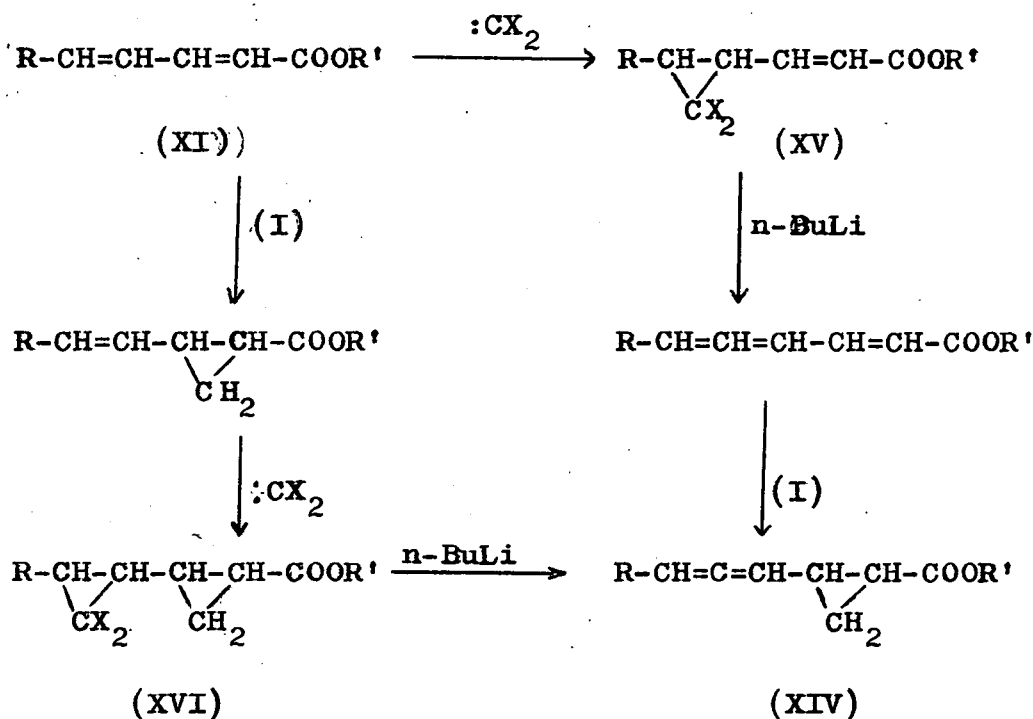

Dihalocyclopropane (XV), however, could not be prepared from ethyl sorbate (XI, R=Me, R'=Et) by the potassium t-butoxide and haloform method as the ester

underwent a Claisen type condensation⁹⁷ to give a polymeric product under the strongly basic conditions used. Hence the generation of dihalocarbenes using ~~an~~ essentially neutral condition seemed imperative. Meanwhile, application of the dimethylsulphoxonium methyllide reagent (I) gave ethyl 2,3-methyleneepent-4-enoate (XII, R=Me, R'=Et) in fair yield, and this should be susceptible to the addition of dihalocarbene to give (XVI, R=Me, R'=Et) and then give the required allenic cyclopropane (XIV, R=Me, R'=Et) using the n-butyl-lithium procedure³².

While this work was in progress, Bagby, Smith and Wolff⁶⁶ presented fresh evidence which established 'Laballenic acid' as a straight-chain allenic acid, octadeca-5,6-dienoic acid and not a cyclopropane allenic acid, (XIV, R=CH₃(CH₂)₁₀, R'=H) as previously advocated⁶⁵.

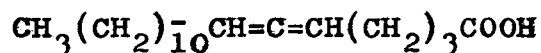

Laballenic acid

The above scheme was therefore abandoned and laballenic acid was synthesised by another reaction sequence (see Discussion, p. 104)

Nevertheless, a study of the sulphoxonium methyllide

reaction was extended in this laboratory to cover different types of unsaturated compounds e.g. the enoic, dienoic and allenic derivatives of esters, nitriles, ketones and malonates.

After this work had been completed, Corey and Chaykovski⁹⁸ reported that ethyl cyclohexenyl carboxylate (XVII), the only unsaturated ester studied, reacted with the methylyde (I) to give a cyclic compound (XIX). However, the work described here shows that acyclic α,β -unsaturated esters did not give such cyclic compounds. The formation of the cyclic product (XIX) would require the following mechanism:-

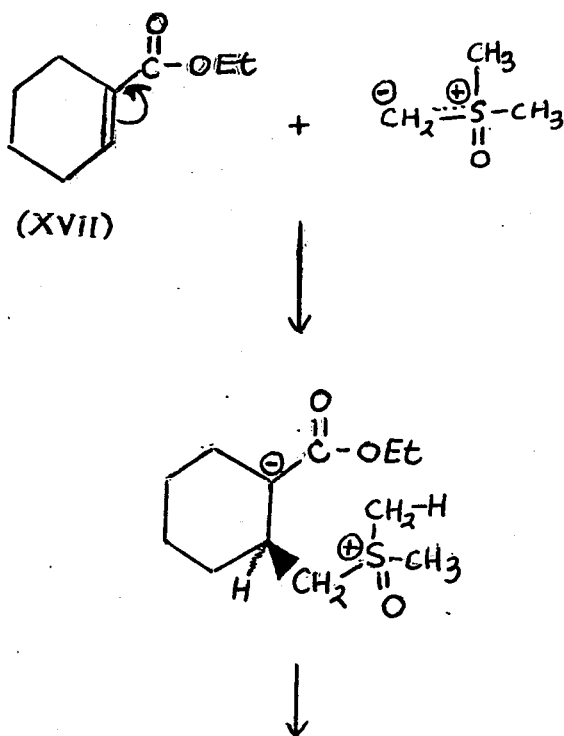

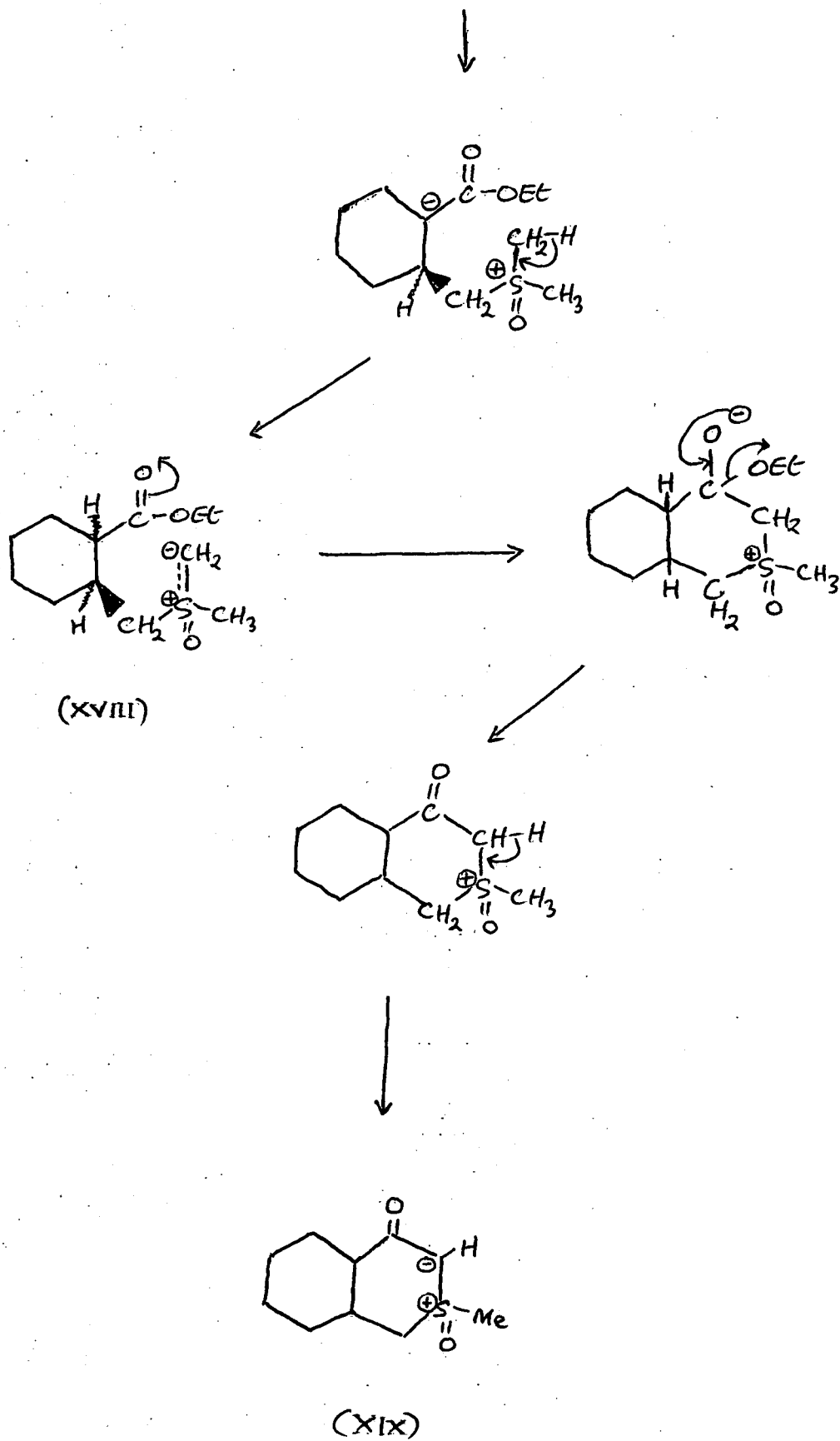

The sulphoxonium intermediate complex with cyclohexane (XVIII) seems to be more favourably placed for cyclisation owing to the strain imposed by the ring system, by a Claisen^{ester}-type of condensation to give the bicyclic compound (XIX) than the equivalent complex with an acyclic system (XX) which preferentially eliminates dimethyl sulphoxide to give the cyclopropane (XXI):

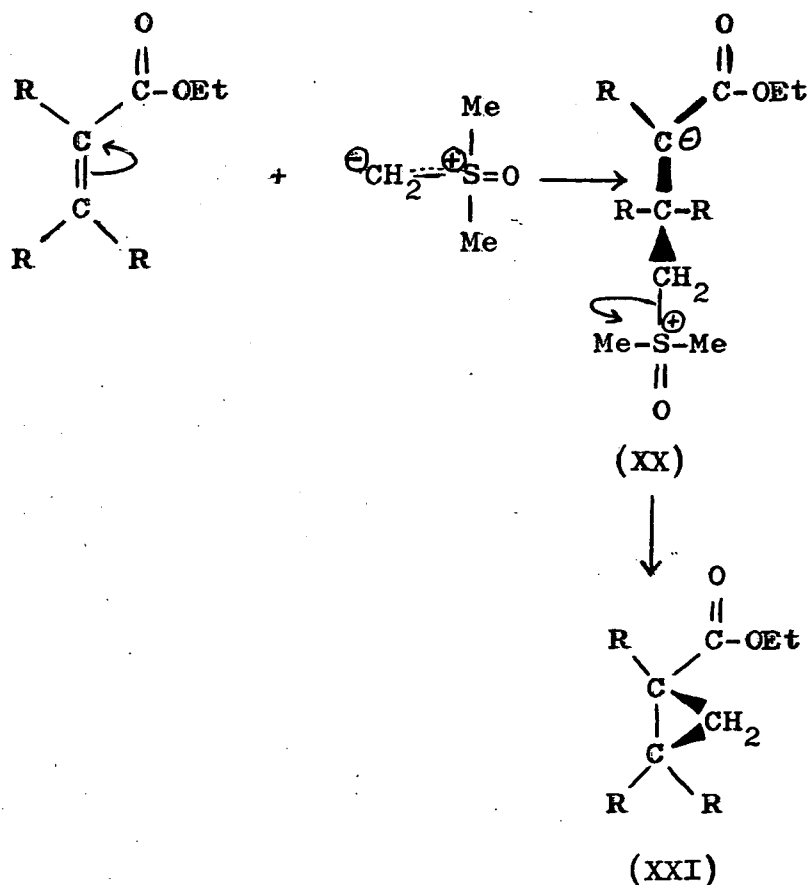

This is borne out by the fact that cyclopropanes were generally obtained in good yield from dimethylsulphoxonium

methylide (I) and α, β -unsaturated esters, both in dimethylsulphoxide (Corey and Chaykovski's method) and by a simplified procedure using dimethylformamide as solvent (Method b).

Formation of the methylide (I) from trimethylsulphoxonium iodide⁹⁸ in dimethyl sulphoxide and sodium hydride requires about 1 hr. as indicated by the evolution of hydrogen, and a further 1-3 hr. is necessary at temperatures of 20-60° to complete the formation of the cyclopropane after the addition of an unsaturated ketone or ester.

On the other hand, the procedure using dimethylformamide as solvent gives improved yields and is particularly useful for compounds with electron donating substituents at the Michael receptor site (such substituents would be expected to slow down the reaction) or readily polymerisable esters (see Table I), compounds (3), (6) and (9)]. Formation of methylide (I) in dimethylformamide is a spontaneous exothermic process which is complete in 5 min. and is accompanied by copious evolution of hydrogen. The addition of α, β -unsaturated ester or ketone to the methylide (I) then gives rise to a further exothermic reaction which is virtually complete in 30 min.

Sodium hydride is reported⁹⁹ to react with diethylformamide to form diethylamine and carbon monoxide at temperatures above 100°. As temperatures between 20-40° were used here for the preparation of cyclopropanes, no difficulties were experienced with side reactions. This temperature range is achieved by controlling the rate of addition of the reactants which controls the amount of heat evolved. Thus no external heating is necessary for any stage of this reaction.

Esters of trans-enoic acids were used throughout this work. G.l.c. using two different stationary phases gave a single peak for each product; hydrogenated product of the cyclopropane ester prepared from a dienolate also gave a single peak on g.l.c. The melting points and mixed melting points of the cyclopropanecarboxylic acids obtained by hydrolysis of the esters compared well with the literatures values. Hence the products were assumed to be essentially the trans-substituted cyclopropanes resulting from stereospecific addition.

N.m.r. spectroscopy provided further evidence for the stereospecificity of the reaction. Ethyl 2-methylcyclopropane-1-carboxylate shows a single quartet for the

ester methylene protons $\left(\begin{array}{c} \text{CH}_3 \\ | \\ \text{---} \text{C} \text{---} \text{C} \text{---} \\ | \quad \quad | \\ \text{H} \quad \quad \text{COOCH}_2\text{CH}_3 \end{array} \right)$ at

γ 5.90 (N.M.R.12). Furthermore, diethyl 2,2-dimethylcyclopropane-1,1-dicarboxylate (XXIII, R=R'=Me) also shows a single quartet for the two equivalent ester methylene protons

$\left(\begin{array}{c} \text{CH}_3 \\ | \\ \text{---} \text{C} \text{---} \text{C} \text{---} \\ | \quad \quad | \\ \text{CH}_3 \quad \quad \text{COOCH}_2\text{CH}_3 \\ \text{CH}_3 \quad \quad \text{COOCH}_2\text{CH}_3 \end{array} \right)$ at γ 5.86 (N.M.R.17); at high

resolution, a diffuse quartet is obtained, probably due to conformational asymmetry. But diethyl 2-methylcyclopropane-1,1-dicarboxylate (XXIII, R=Me, R'=H) shows two quartets (separated by 2.4 c./sec.) centred at γ 5.82 and 5.86 (J=7.2 c./sec. for each quartet) (N.M.R.13) probably due to the magnetic influence of the cis-methyl and hydrogen-substituent on the cyclopropane ring. Two quartets would similarly be expected for a mixture of the cis- and trans- ethyl 2-methylcyclopropane-1-carboxylate owing to a different magnetic effect caused by each geometrical isomer. The single sharp quartet observed for ethyl 2-methylcyclopropane-1-carboxylate thus also indicates that it is essentially the trans- isomer (>95%).

It was found that in every case where the alkyl substituents on the β -carbon of the alkylidene malonate or

the 2-carbon of the cyclopropyl malonate are different (i.e. XXII and XXIII $R \neq R'$), two quartets for the nonequivalent pair of ester methylene protons and two triplets for the nonequivalent pair of ester methyl protons are observed (see N.m.r. Nos.13-22). This cannot be due to extended spin-spin interaction as the nearest proton from the ester methylene group is separated by at least four atoms. This phenomenon is observed only when there is asymmetry about the double bond or cyclopropane (i.e. when $R \neq R'$) and when a pair of carboxylic ester group is attached to the double-bonded carbon or cyclopropane ring, and may be due either to the proximity of the two carboxylic ester groups so that the restricted rotation of the ester ethyl groups makes them nonequivalent, or due to the magnetic influence of the cis-alkyl substituents on the $>C=C<$ or cyclopropane ring.

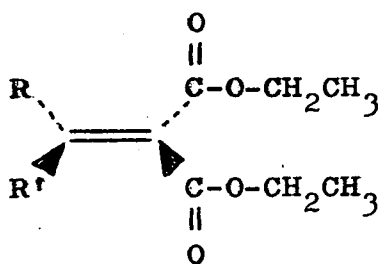

(XXII)

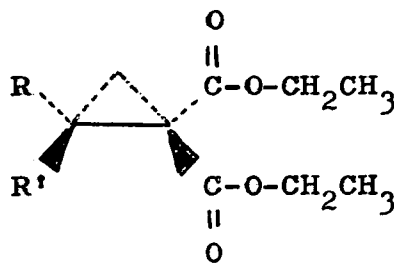

(XXIII)

It had already been demonstrated that dienone Michael receptors with methylyde (I) gave α, β - or γ, δ -addition according to steric considerations. Thus eucarvone gave the α, β -adduct⁵² (XXIV) because of steric inhibition of the γ, δ -double bond by the 6,6-dimethyl group whereas 17-hydroxy-androsta-4,6-dien-3-one added the methylyde (I) to the more exposed 6,7-double bond to give the cyclopropane (XXV)¹⁰⁰

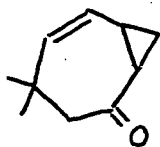

(XXIV)

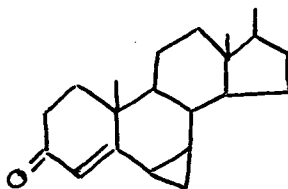

(XXV)

Both ethyl dienoates investigated here, ethyl penta-2,4-dienoate and ethyl hexa-2,4-dienoate, gave mainly the α, β -adducts (XXVI, R=H or Me, R'=Et) indicating that in the absence of strong steric effects, attack in the 3-position of the Michael receptor is preferred to attack in the 5-position.

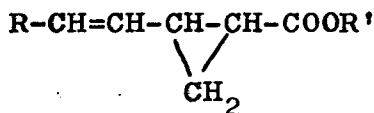

(XXVI)

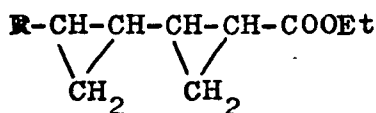

(XXVII)

However, under forcing conditions, with a four-fold excess of methyllide (I), ethyl hexa-2,4-dienoate gave 35 per cent of the bis-adduct (XXVII) showing that γ, δ -attack can be realised. A poor yield of the γ, δ -adduct (XXVIII, R=Me, R'=Et) was also isolated as one of the reaction products, and identified by elemental analysis, i.r. and u.v. spectroscopy.

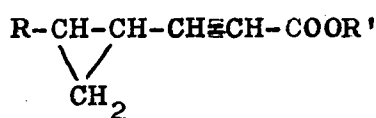

(XXVIII)

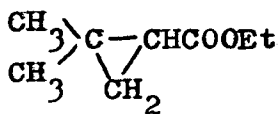

(XXIX)

Ethyl 3,3-dimethylacrylate gave only a 9 per cent yield of the corresponding cyclopropane (XXIX) by the dimethylformamide procedure although a two-fold excess of the methyllide (I) was used. This result cannot be explained on grounds of steric inhibition to attack by methyllide (I) as the analogous malonate and ketone give 91 per cent and 76 per cent yields of the corresponding cyclopropanes [Table I, (11) and (16)]. Electron donation by two methyl groups apparently cancels the effect of the weak electron attraction of a single carboxylic ester

group at the Michael receptor site, but not the electron attraction of two carboxylic ester groups or a ketone carbonyl group.

1-Cyanoallenes gave only 10 per cent of distillable products by both the dimethyl sulphoxide and dimethylformamide procedure; i.e., u.v. and n.m.r. spectra indicated that these consisted mainly of isomerised 1,3-dienes. The bulk of the product was polymeric.

Ethyl buta-2,3-dienoate (prepared by the method of Eglinton, Jones, Mansfield and Whiting¹⁶²) gave a product which was largely water-soluble, and evaporation of the aqueous extracts gave a solid, probably the resonance stabilised adduct (XXX):-

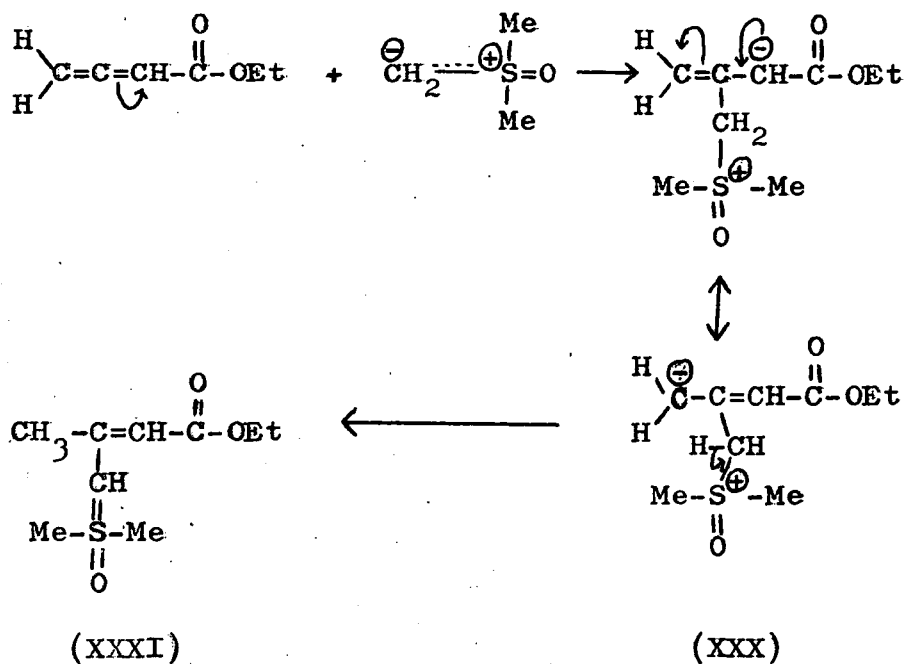

In the absence of water (i.e. the absence of protons for decomposing the intermediate complex) and on evaporation of the solvent, a quantitative yield of an oily product was obtained which had similar u.v. absorption to that of dimethylsulphoxonium 3-ethoxycarbonyl-2-phenylallylide, obtained from ethyl phenylpropiolate^{56,102}. This compound (XXXI) formulated as dimethylsulphoxonium-3-ethoxycarbonyl-2-methylallylide, however, was unstable, with a half-life of 90 min., and could not therefore be isolated.

Ethyl 4-phenyl-penta-2,3-dienoate¹¹⁵ gave the recovered allene ester presumably due to the steric inhibition of the methyl and phenyl groups on the β -carbon, i.e. the site at which the methyllide (I) is supposed to attack.

It was interesting to compare the u.v. absorption spectra of cyclopropyl esters with those of the corresponding α, β -unsaturated esters. Although the conjugative influence due to the cyclopropane ring (considering either Walsh's model¹⁰³ or a "bent-bond" model¹⁰⁴) has been reported since the inception of the concepts of sp , sp^2 and sp^3 hybridisation and of σ and π bonds in the early 1930's, no satisfactory unified account of and theoretical explanation for the u.v. absorptions of compounds containing

cyclopropyl group in combination with carbonyl group and neighbouring olefinic group has been published.

Smith and Rogier¹⁰⁵ in 1951 observed that there was no significant difference ^{in the u.v. spectrum} between cyclopropane (XXXII) and alkyl substituted benzenes (XXXIII), R=alkyl).

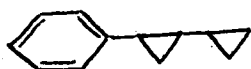

(XXXII)

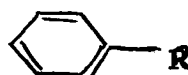

(XXXIII)

Thus it was shown that a terminal cyclopropyl group plays no part in conjugation. Similarly Eastman¹⁰⁶ showed that compounds (XXXIV) and (XXXV) had similar u.v. absorption (in the position of the maxima and intensity).

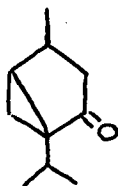

(XXXIV)

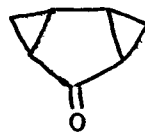

(XXXV)

$$\lambda_{\max} 214 \text{ m}\mu (\epsilon, 2,990)$$

$$\lambda_{\max} 275 \text{ m}\mu (\epsilon, 62)$$

$$\lambda_{\max} 210 \text{ m}\mu (\epsilon, 2,470)$$

$$\lambda_{\max} 280 \text{ m}\mu (\epsilon, 35)$$

Eastman and Freeman¹⁰⁷, however, observed that the u.v. absorptions of compounds (XXXVI) and (XXXVII) were also similar:-

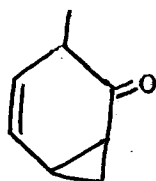

(XXXVI)

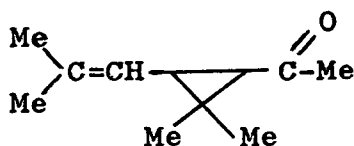

(XXXVII)

$$\lambda_{\max} 235.5 \text{ m}\mu (\epsilon, 13,600) \quad \lambda_{\max} 237 \text{ m}\mu (\epsilon, 13,600)$$

But their u.v. absorption was different from the calculated value for the $\overset{\overset{\text{C}}{\text{C}}}{\text{C}}=\overset{\overset{\text{C}}{\text{C}}}{\text{C}}-\overset{\overset{\text{C}}{\text{C}}}{\text{C}}-\overset{\overset{\text{C}}{\text{C}}}{\text{C}}=0$ system (by Woodward's rule¹⁰⁸, λ_{\max} ca. 300 m μ).

On the other hand the u.v. absorption of compound (XXXVIII) was approximately the same as that calculated for the $\overset{\overset{\text{C}}{\text{C}}}{\text{C}}=\overset{\overset{\text{C}}{\text{C}}}{\text{C}}-\overset{\overset{\text{C}}{\text{C}}}{\text{C}}-\overset{\overset{\text{C}}{\text{C}}}{\text{C}}=0$ system. This was explained theoretically by Roberts and Nazur¹⁰⁹ as being due to the electron delocalisation causing the collapse of the bicyclic system (XXXVIII) to a dipolar system (XXXIX) in which the positive charge is delocalised over four ring-carbon atoms 3, 4, 5, and 6.

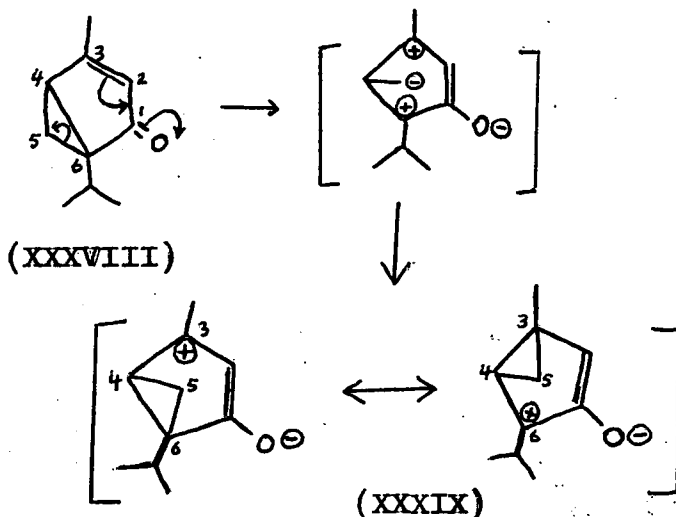

Hence it was concluded that conjugation is possible when the cyclopropane ring is at the end of a conjugated chain but not with contiguous unsaturated groups. Eastman and Freeman¹⁰⁷ stated thus: "The cyclopropane ring bears little chromophoric similarity to the vinyl group when placed as a connecting link between chromophores, i.e. unsaturated electrons of the cyclopropane ring lack the property of π electrons in general of functioning centrally in a chain of conjugation."

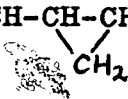
Work done here confirms some of the above conclusions but arrives at a slightly different results. Both cyclopropyl esters and the corresponding α, β -unsaturated esters absorb in the same region of the u.v. spectrum at 206-210 $m\mu$, but the intensity of the cyclopropyl ester (ξ , 100-200) is between 30 to 80 times weaker than the unsaturated ester (ξ , 8000-13,000). Cyclopropyl ketones also absorb near 207 $m\mu$ (ξ , 1300-2,500), but alkyl substitution does not produce the normal bathochromic shifts¹¹⁰ produced by substituents on unsaturated ketones. A cyclopropane between two unsaturated groups as in $\text{Me-CH=CH-CH-CH-COOEt}$

effectively blocks conjugation. However, the intensity of the normal absorption band at 207 $m\mu$ is increased ten-fold

(to ξ , 3,700). This corresponds to a high energy transition, and there can be little delocalisation of the "bent bond" electrons in the cyclopropane. On the other hand, a surprisingly large bathochromic shift ($\Delta\lambda=30 \text{ m}\mu$) results from a β -cyclopropyl substituent on the 2-enoic ester group as in Me- $\underset{\text{CH}_2}{\text{CH}}\text{-CH-CH=CH-COOEt}$, together with an increase in intensity (ϵ , 5,000-10,000). However, the u.v. absorption maximum of (XIII, R'=Et) differs from that of the dienolate (XI, R'=Et) by 20 $\text{m}\mu$ and it is almost half ^{the} intensity, unlike that of the bicyclic system (XXXVIII) quoted by Eastman and Freeman¹⁰⁷.

Table I lists the cyclopropane esters prepared by the dimethylsulphoxonium methylyde reaction and compares their u.v. absorptions with those of their α, β -unsaturated precursors.

/Table I...

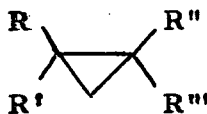
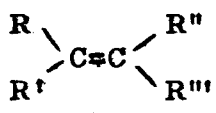

TABLE I

Cyclopropane Esters

	R	R'	R''	R'''	b.p./°C	Yield(%) by Method A	Yield(%) by Method B
1	H	H	H	COOEt	134	65	-
2	Me	H	H	COOEt	76/70	60	62
3	H	H	Me	COOMe	72/120	0	29
4	Me	Me	H	COOEt	-	-	9
5	Pr	H	H	COOEt	80-82/5	-	79
6	Ph	H	H	COOEt	110/1	30	42
7	CH ₂ =CH	H	H	COOEt	58/1	62	-
	H	H	H	CH=CHCOOEt	-	-	-
8	MeCH=CH	H	H	COOEt	106/15	47	-
	Me	H	H	CH=CHCOOEt	106-108/15	10	-
9	COOEt	H	H	COOEt	108-110/12	-	47
10	Me	H	COOEt	COOEt	66-68/0.5	-	80
11	Me	Me	COOEt	COOEt	85-86/0.5	-	91
12	Et	H	COOEt	COOEt	102-104/3	-	85
13	iso-Pr	H	COOEt	COOEt	110/2.1	-	89
14	Ph	H	COOEt	COOEt	140/0.1	-	76
(15	Me	Me	H	COMe	40-42/30	-	76)

/TABLE I contd...

TABLE I/continued

				
	λ_{\max} ($m\mu$)	ϵ	λ_{\max} ($m\mu$)	ϵ
1	206	4,785	207	106
2	208	13,115	206	160
3	208	8,511	206	194
4	-	-	-	-
5	210	13,100	207	187
6	277	19,215	220	8,500
7	247	23,200	205	2,890
	"	"	230.5	16,500 ¹¹²
8	258	29,390	207	3,700
	"	"	235	17,160
9	246	639	207	477
10	210	12,750	210	300
11	209	13,020	204	541
12	210	13,090	208	342
13	209	13,290	209	402
14	280	24,055	218	10,480
(15	237	10,470	207	2,485)

Asymmetric Synthesis of Cyclopropane Esters from the α,β -Unsaturated Esters by the Dimethylsulphoxonium Methylide Reaction

Partial asymmetric synthesis of trans-2-phenylcyclopropanecarboxylic acid has been a subject of recent investigation using methods involving diazomethane on (-)-menthyl cinnamate¹¹⁶, phenyl-magnesium-bromide on (-)-menthyl 4-bromo-pent-2-enoate¹¹⁶ and Simmons-Smith reagent (IZnCH_2I) on α,β -unsaturated esters⁹⁵, followed by alkaline hydrolysis.

In order to determine the stereospecificity of the dimethylsulphoxonium methylide reaction with α,β -unsaturated esters, we chose an optically active aromatic and aliphatic α,β -unsaturated ester, i.e. (-)-menthyl cinnamate and (-)-menthyl crotonate, the configuration of both these enoates and their corresponding cyclopropanes being well known^{95,116,117,118}. It was found that for both the esters, the alkaline hydrolysis of the (-)-menthyl cyclopropanecarboxylates gave (-)-cyclopropanecarboxylic acids. The purity of the acids were determined by melting point, mixed melting point and g.l.c. on the ethyl esters prepared from them.

Inouye, Takehana, Sawada and Ohno⁹⁵ obtained (+)-

(1S,2S)-2-methylcyclopropanecarboxylic acid¹¹⁸ and (-)-(1R,2R)-2-phenylcyclopropanecarboxylic acid^{116,117} by the Simmons-Smith reaction with (-)-menthyl crotonate and (-)-menthyl cinnamate respectively. They explained this results by considering a methylene transfer mechanism through a transition intermediate involving simultaneous coordination of zinc of the Simmons-Smith reagent with ester carbonyl oxygen which gives a twisted cisoidal conformation of both the α,β -unsaturated esters.

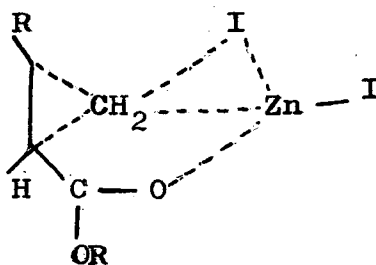

In the case of the aliphatic ester, the release of zinc iodide led to the formation of (+)-(1S,2S)-cyclopropanecarboxylic acid as expected. But for the aromatic ester, the conjugation with the phenyl group, they explained, enhanced the nucleophilicity of the partial α,β -double bond so that another molecule of the Simmons-Smith reagent attacks this bond and the methylene transfer takes place at the side which is less hindered, thus leading to the formation of (-)-(1R,2R)-cyclopropanecarboxylic acid.



In our investigation, we obtained the laevorotatory cyclopropanecarboxylic acids for both these examples, and therefore the same stereochemical mechanism must operate for both of them.

After this work was completed, a paper by Nozaki, Ito, Tunemoto and Kondo¹¹⁹, who used (-)-menthyl cinnamates (with and without ring substituents) and dimethylsulphoxonium methylide and dimethylsulphonium methylide followed by alkaline hydrolysis showed that they also obtained laevorotatory 2-arylcyclopropanecarboxylic acids.

As the laevorotatory cyclopropanecarboxylic acid has the configuration (1R,2R)¹¹⁷, the following mechanism involving ^{of the methylide on the ester in its preferred conformation from the} ~~which the attack of the conformer from the side of the~~ smallest groups, must operate:-

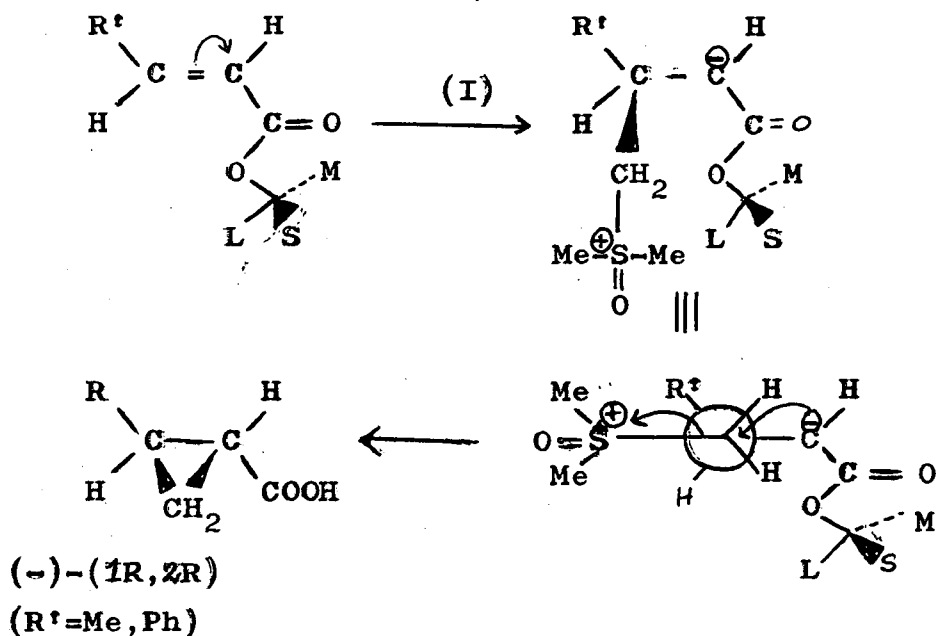

Synthesis and Absolute Configuration of Naturally
Occurring Non-conjugated Allenic Acid

Laballenic Acid

The second publication by Bagley, Smith and Wolff⁶⁶ demonstrated that, contrary to earlier evidence⁶⁵ (see Introduction p.34), the structure of laballenic acid must be octadeca-5,6-dienoic acid:-

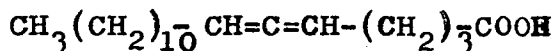

The evidence rested mainly on spectroscopic and chemical analysis, details of which are given in the Introduction.

This acid was synthesised in this laboratory by the following route:-

1-Tetrahydropyranyloxy-pent-2-en-4-yne (I) with lithium in liquid ammonia and n-undecyl bromide gave 1-tetrahydropyranyloxyhexadec-2-en-4-yne (II, R=tetrahydropyranyl) which was hydrolysed to hexadec-2-en-4-yn-1-ol (II, R=H). This was reduced with lithium aluminium hydride¹²⁰ to give hexadeca-3,4-dien-1-ol (III) which was converted to the corresponding bromide by the triphenylphosphite dibromide method¹²¹. 1-Bromohexadeca-3,4-diene and diethyl sodiomalonate gave the hexadeca-3,4-diene^{malonic ester} (IV) which was hydrolysed and decarboxylated to give

laballeic acid (V, R=H).

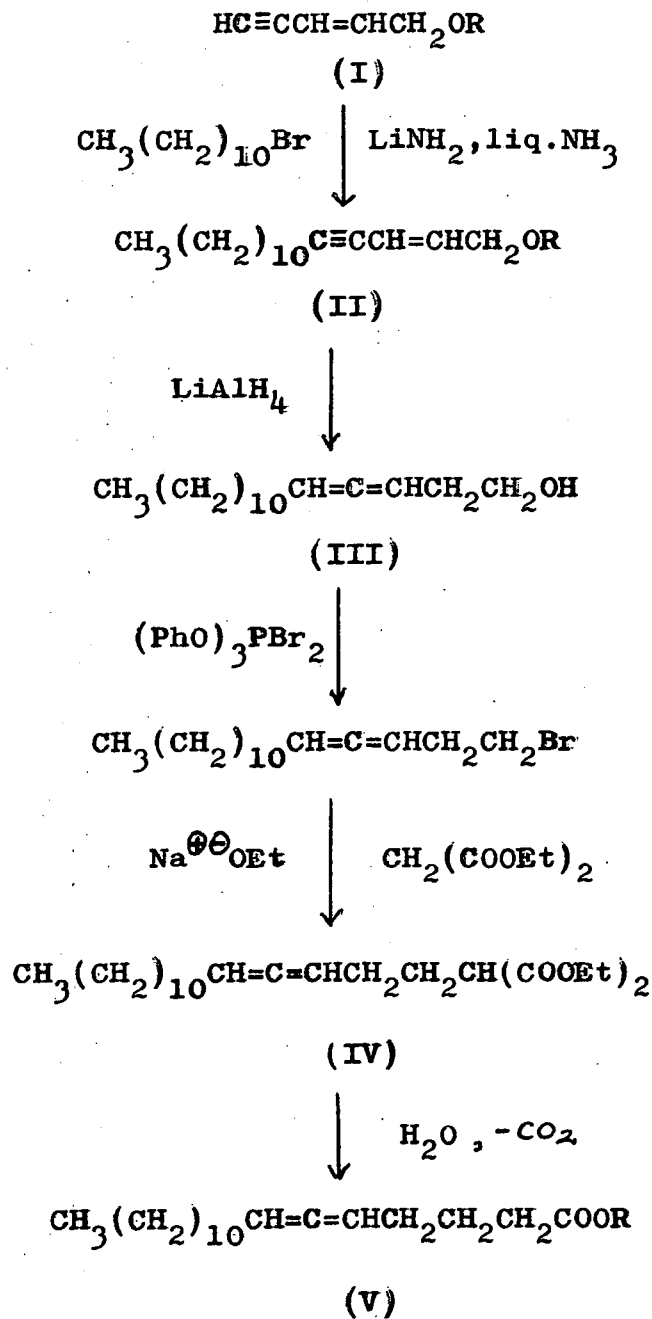

alkylation of acetylenes proceeded more smoothly in the presence of lithamide rather than sodamide in liquid ammonia owing to a difference in solubility. Thus *n*-undecyl bromide (prepared by the method of Luttringhaus and Schade¹²⁶) was added to 1-tetrahydropyranyloxy-pent-2-en-4-yne (I) in the presence of lithamide in liquid ammonia to give a 57% yield of 1-tetrahydropyranyloxyhexadec-2-en-4-yn-1-ol (II, R=tetrahydropyranyl). Evans¹²⁷ was unable to isolate the pure tetrahydropyranyl ethers and he hydrolysed the impure derivative by heating it under reflux with concentrated hydrochloric acid in methanol for several hr. Miller¹²⁸, however, found that purification of the ethers by distillation followed by hydrolysis of the pure ether gave a better yield of the required unsaturated alcohols.

1-Tetrahydropyranyloxyhexadec-2-en-4-yne (II, R=tetrahydropyranyl) was therefore distilled and the pure tetrahydropyranyl ether hydrolysed with hydrochloric acid/methanol to yield 56% hexadec-2-en-4-yn-1-ol (II, R=H), and the enynol was reduced with lithium aluminium hydride^{123,129} to give hexadeca-3,4-dien-1-ol. Each compound gave correct elemental analysis and gave essentially a single peak on the g.l.c. The spectroscopic evidence fitted well

with their structures e.g. 1-tetrahydropyranyloxy-hexadec-2-en-4-yne (II, R=tetrahydropyranyl) showed bands in the i.r. spectrum at $\bar{\nu}_{\max}$ 2230m (conjugated $\text{-C}\equiv\text{C-}$), 1650m (C=C), 960s ($\text{HC}\equiv\text{CH}$) and the characteristic tetrahydropyranyl ether bands at 1195ms, 1175m, 1120vs, 1015vs, 870s and 814s cm.^{-1} ; for hexadec-2-en-4-yn-1-ol (II, R=H) at $\bar{\nu}_{\max}$ 3400s (-OH), 2230m (conjugated $\text{-C}\equiv\text{C-}$), 1650 (C=C), 960s ($\text{HC}\equiv\text{CH}$) cm.^{-1} ; and for hexadeca-3,4-dien-1-ol (III) at $\bar{\nu}_{\max}$ 3400s (-OH), 1950m (C=C=C) cm.^{-1} . The u.v. spectra of (I, R= H^{130} and tetrahydropyranyl) and (II, R=H and tetrahydropyranyl) were similar as expected (See U.V.No.11).

The 1-bromohexadeca-3,4-diene could not be isolated in pure form. Fractionation gave a dark liquid. It was, distilled from triphenylphosphate and the crude distillate was used in the next stage of the reaction.

Laballenic acid was isolated as an oil which could not be distilled on a mercury vapour pump nor could the oil be crystallized. It showed $\bar{\nu}_{\max}$ 3300, 1600b (COOH), 1950w (C=C=C) and 1700s (C=O) cm.^{-1} ; the p-bromophenacyl ester was prepared and crystallized from ethanol and identified by elemental analyses as well as by melting point correlation with the same derivative prepared by Bagley, Smith and

Wolff⁶¹⁶, Methyl laballenate was prepared from laballenic acid, methanol and hydrogen chloride and gave correct elemental analysis, with the expected 1950w (C=C=C) and 1750s (C=O) bands in the i.r. spectrum. It gave a single peak on g.l.c. Hydrogenation of the ester using Adam's platinum oxide yielded methyl stearate identified by melting and mixed melting point.

(R)-(-)-Laballenic Acid

When hexadec-2-en-4-yn-1-ol (II, R=H) was reduced with the lithium aluminium hydride-3-O-benzyl-1,2-cyclohexylidene-D-glucosfuranose complex¹³⁰, (-)-hexadeca-3,4-dien-1-ol $[\alpha]_D^{20} -4.4^\circ$ was obtained.

Landor, Miller, Regan and Tatchell¹³¹ showed that reduction of 2-en-4-yn-1-ols with this sugar complex gives allenic alcohols of the (R)-configuration. This was based on the following arguments:-

When alk-2-en-4-yn-1-ols were reduced with lithium dimethoxyaluminium hydride, the corresponding (+)-allenic alcohols were shown to have the (S)-configuration due to the predominance of the thermodynamically more stable cyclic allene complex leading to the preferred (S)-configuration. This was confirmed by a Claisen type

prepared from (S)-(-)-but-1-yn-3-ol, acetaldehyde and boron trichloride of rearrangement of (-)-but-1-yn-3-yl- α -chloroethyl ether to give (S)-(+)-hexa-3,4-dien-1-ol via a six-membered *followed by lithium aluminium hydride reduction of the aldehyde cyclic transition state*. On the other hand when the same alk-2-en-4-yn-1-ols were reduced with the lithium aluminium hydride-3-O-benzyl-1,2-O-cyclohexylidene-D-glucosyl complex, the corresponding (-)-allenic alcohols were obtained, hence these must have the (R)-configuration.

This was borne out by an examination of models which showed that the (R)-isomer would be expected to be thermodynamically more stable than the (S)-isomer¹³².

On the basis of the above result, (-)-hexadeca-3,4-dien-1-ol has the (R)-configuration. Conversion via the bromide to the malonic ester and hydrolysis and decarboxylation gave (-)-laballenic acid (V) $[\alpha]_D^{20} -3.0^\circ$ and the (-)-methyl ester $[\alpha]_D^{20} -3.0^\circ$. Hence laballenic acid and its methyl ester also have the (R)-configuration. As the methyl ester from the naturally occurring laballenic acid is described as having $[\alpha]_D^{20} -47.3^\circ$, it must have the (R)-configuration. This conclusion is supported by a theoretical deduction based on an extension of Brewster's theory^{133,134} which predicts on the basis of polarisabilities of substituents, that the system (VI) should have a negative rotation.

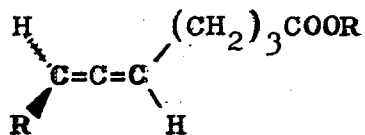

(VI)

8-Hydroxy-octa-5,6-dienoic Acid

Sprecher, Maier, Barber and Holman⁶⁸ in 1965 isolated an optically active lipid from the seed oil of the Chinese tallow tree, *Sapium Sebeferum*, and showed by degradative, chromatographic and mass spectrographic techniques that one of its acid components was 8-hydroxy-5,6-octadienoic acid (VII). Three derivatives of (VII) were prepared and all were found to be optically active, the optical activity being due to the allene function.

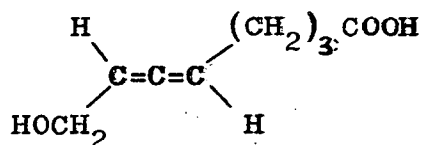

(VII)

The structure of (VII) was deduced from i.r. and mass spectra and chemical evidence (see p.35)

(VII) is similar to laballenic acid (octadeca-5,6-dienoic acid, the synthesis of which is described in this thesis) except that the undecyl substituent is replaced by a hydroxymethylene group. The synthetic approach

to the hydroxy allenic acid (VII) was, therefore, similar to that employed for the synthesis of laballenic acid, i.e. the preparation of the en-yn-ol followed by lithium aluminium hydride reduction to the corresponding allenic alcohol and finally the malonic ester condensation of the allenic bromide and hydrolysis and decarboxylation of the malonate.

It was desirable to choose an enynol which would be reduced by lithium aluminium hydride to the corresponding allenic alcohol and yet contain another function which is stable under alkaline condition and can be easily hydrolysed or converted to the required alcohol at a latter stage.

135,136

A method involving the use of tetrahydropyranyl ether was considered, so that, for instance, tetrahydropyranyloxy prop-2-yne (VIII) would be expected to give the required en-yn-olic ether (IX)

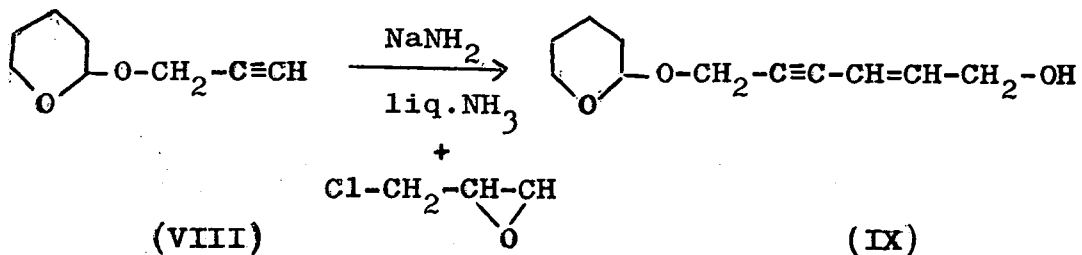

This was found to be the case. And tetrahydropyranyl

ethers are easy to make¹³⁵, known to be resistant to alkaline conditions^{137,138} and also that they are easily hydrolysed to the corresponding alcohols by mild acid treatment^{135,137}, e.g. Henbest, Jones and Walls¹³⁷ have synthesised 4-hydroxy-but-2-ynoic acid (X) by a method involving the use of tetrahydropyranyl ether followed by its hydrolysis:-

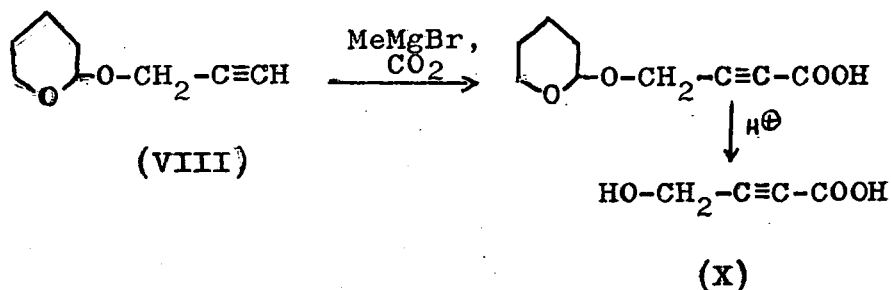

1-Tetrahydropyranyloxy-prop-2-yne (VIII) was prepared by shaking propargyl alcohol with a 25% molar excess of 2,3-dihydropyran in the presence of a catalytic quantity of concentrated hydrochloric¹²⁸ acid or p-toluenesulphonic acid¹²⁴, and it was added to sodamide in liquid ammonia followed by the addition of half the theoretical quantity of epichlorohydrin^{128,136}. Upon distillation, a forerun of the recovered 1-tetrahydropyranyloxy-prop-2-yne and 1-tetrahydropyranyloxy-2-furylethane (XI) (in 20% yield) was obtained, followed by the required 1-tetrahydropyranyloxy-~~hex~~-2-yn-4-en-6-ol (IX) (in 35% yield).

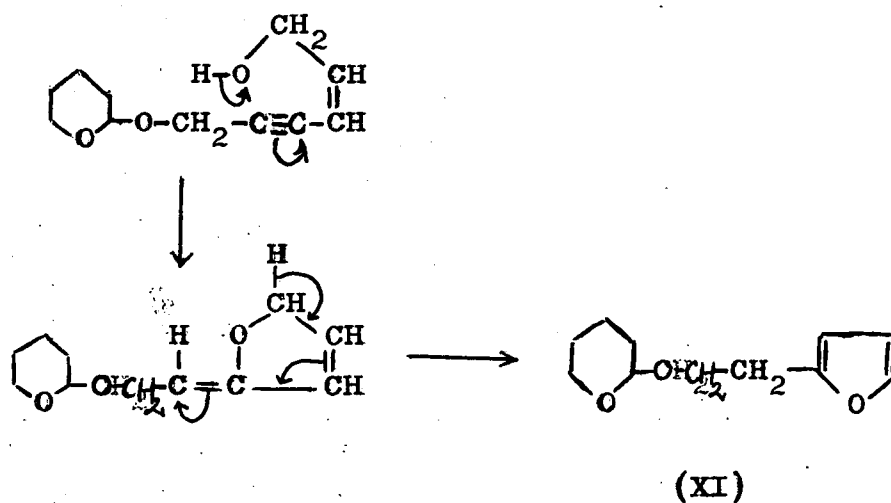

1-Tetrahydropyranyloxy-2-furylethane (XI) was identified by correct elemental analysis, i.r. spectrum showing the typical sharp aromatic bands¹³⁶ of the furan group), u.v. spectrum and by hydrolysis to the corresponding 2-furyl ethanol which had identical physical constants with this compound reported in the literature¹³⁹.

Pepper¹³⁶ as well as Bates, Jones and Whiting¹²³ have isolated furyl derivatives from the products of synthesis of various en-yn-ols by this method and have explained it as arising from the production of the cis-isomer which then cyclises under alkaline condition to give a minor, more volatile fraction. Thus 1-tetrahydropyranyloxy-2-furylethane (XI) can be produced by the following mechanism:-

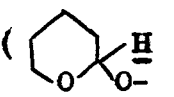
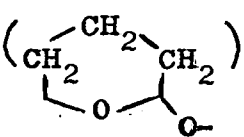

1-Tetrahydropyranyloxy-hex-2-yn-4-en-6-ol (IX) was

isolated as a thick, amber oil after distillation on a mercury-vapour pump. It was identified by i.r. spectrum (showing ν_{\max} at 3400s (-OH), 2230m (conjugated $\text{-C}\equiv\text{C-}$), 1650m ($\text{C}=\text{C}$), 955 ($\text{C}\equiv\text{C}$) and the characteristic tetrahydropyranyl ether bands at 1184ms, 1120ms, 1020s, 1015s, 920s, 870s and 816s cm^{-1} .), u.v. spectrum [similar to the u.v. spectra of en-yn-ols and their tetrahydropyranyl ethers (see u.v. No.11)], n.m.r. and elemental analysis.

N.m.r. of (IX) (See N.m.r. No.9) showed a singlet for the tetrahydropyranyl proton () at τ 6.67, a singlet for the hydroxyl proton ($\text{-CH}_2\text{-O-H}$) at τ 7.20, a singlet for the three equivalent methylene protons of the tetrahydropyranyl group () at τ 8.32, a doublet of triplets due to the trans-olefinic proton ($\text{O-CH}_2\text{-CH=CH-C}\equiv\text{C-CH}_2\text{-O-}$) centred at τ 4.24 ($J=3.0$ c./sec), a doublet for the methylene protons () at τ 5.61 ($J=3.0$ c./sec.) and a doublet of doublets for the methylene protons ($\text{C}\equiv\text{C-CH=CH-CH}_2\text{-O-H}$) centred at τ 5.81 ($J=6.0$ c./sec.).

Reduction of 1-tetrahydropyranyloxy-hex-2-yn-4-en-6-ol (IX) using lithium aluminium hydride gave a product which was not the expected tetrahydropyranyloxy allenic alcohol

(XII), but which on distillation gave a relatively volatile compound, in 45% yield. This showed a strong terminal allene band in the i.r. spectrum (1960s, 845b cm.^{-1}) as well as a hydroxyl band (3400s cm.^{-1}) but did not show the characteristic tetrahydropyranyl ether bands. This group was, therefore, absent in this fraction and despite the fact that no acidic conditions were employed during the working up and isolation of the product, the residue contained the starting material (IX).

It was reasoned that the tetrahydropyranyloxy group was lost during the reduction stage. Up to 60% of the volatile fraction which contained the terminal allene group was obtained if two moles of lithium aluminium hydride per mole of enynol (IX) was used, and all the starting material was used up.

Analysis of the volatile fraction gave an empirical formula of $(\text{C}_6\text{H}_{10}\text{O})_n$. G.l.c. on celite columns using dinonylphthalate and silicone oil as stationary phases showed in each case a single component with a shoulder (see G.l.c.No.1). This shoulder was resolved on the column using polypropylene sebacate as a stationary phase, and this showed the presence of two components in the ratio 7:3 (See G.l.c.No.2).

The mixture of products was acetylated and the acetates distilled. The distillates retained the strong terminal allene band in the i.r. spectrum (1960s, 845b cm.^{-1}), but g.l.c. on polypropylene sebacate still showed two compounds in the ratio 7:3. Elemental analysis of the esters gave a correct value corresponding to the acetyl derivative of the alcohol of empirical formula $(\text{C}_6\text{H}_{10}\text{O})_n$. Hence this mixture probably consisted of esters of isomeric alcohols. It had no significant u.v. absorption.

The N.m.r. spectrum of the mixture of alcohols showed a triplet for the two protons on C_1 ($\text{C}=\text{C}-\overset{3}{\text{C}}\text{H}-\overset{2}{\text{C}}\text{H}_2-\overset{1}{\text{C}}\text{H}_2-\text{OH}$) centred at τ 6.32 ($J=6.0$ c./sec.) and another triplet for the two protons on C_3 ($-\text{C}\equiv\text{C}-\overset{3}{\text{C}}\text{H}_2-\overset{2}{\text{C}}\text{H}_2-\overset{1}{\text{C}}\text{H}_2\text{OH}$) centred at τ 6.28 ($H=6.0$ c./sec.), a singlet for the three protons ($\text{CH}_3-\text{C}\equiv\text{C}-\text{CH}_2-$) at τ 8.22, and a multiplet for the $\text{CH}_2=\text{C}=\text{CH}-\text{CH}_2$ system at τ 5.38 (see N.m.r. No.8).

N.m.r. of the acetate derivative similarly showed the above characteristics of a mixture of terminal allene and internal acetylene.

This mixture according to the above data is, therefore, hexa-4,5-dien-1-ol (70%) and hex-4-yn-1-ol (30%). Hydro-

generation of the mixture gave n-hexanol, identified by comparison of i.r. spectra and g.l.c. with an authentic sample. As a final check, penta-3,4-dien-1-ol was prepared^{122,123,129} from the lithium aluminium hydride reduction of trans-pent-2-en-4-yn-1-ol, its i.r. spectrum compared with the above mixture, and found to be very similar (see I.R.Nos. 60 and 61). Hence lithium aluminium hydride reduction of 1-tetrahydropyranyloxy-hex-2-yn-4-en-6-ol (IX) gives a mixture of hexa-4,5-dien-1-ol and hex-4-yn-1-ol, probably by a mechanism involving a β -elimination of the tetrahydropyranyl ether group followed by reduction of the cumulene intermediate by the excess lithium aluminium hydride.

Landor, Landor and Pepper¹⁴⁰ have proposed a mechanism postulating a cumulene intermediate in the formation of en-yn-ols from chloro-diynols with lithium aluminium hydride as follows:-

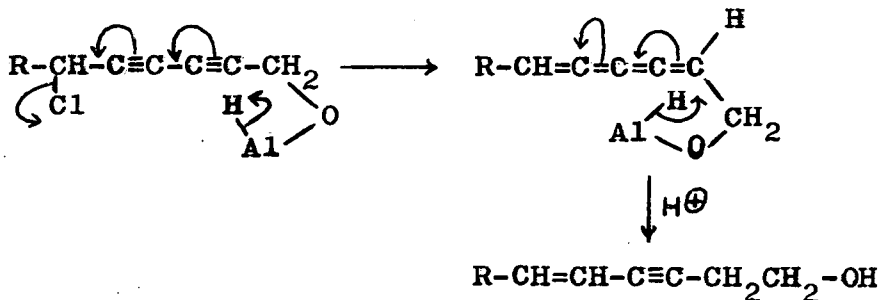

A similar mechanism probably operates in the reduction

of 1-tetrahydropyranyloxy-hex-2-yn-4-en-6-ol in which the tetrahydropyranyloxy group undergoes elimination as it is also in the β -position to the acetylene.

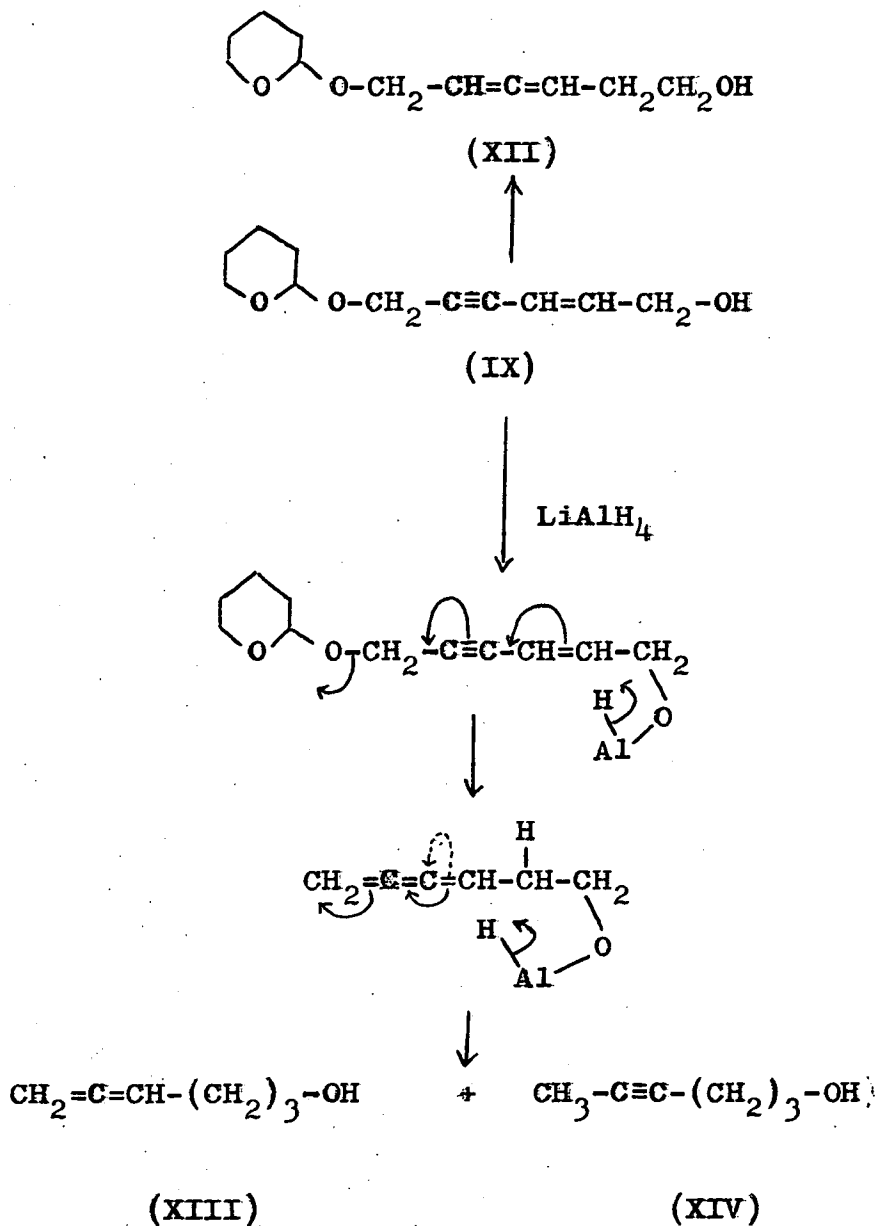

The reaction conditions were varied as follows in

an attempt to prevent the elimination of the tetrahydropyranyloxy group:-

(1) Half a mole of lithium aluminium hydride per mole of 1-tetrahydropyranyloxy-hex-2-yn-4-en-6-ol (IX) gave 80% recovered starting material and a 20% yield of the alcohol mixture (XIII) and (XIV).

(2) One mole of lithium aluminium hydride per mole of the enynol (IX) gave 45% yield of the mixture (XIII) and (XIV), the residue being the starting material.

(3) The use of two moles of lithium aluminium hydride as (2) gave complete reduction of the enynol (IX) to the mixture of allenic and acetylenic alcohols (XIII) and (XIV).

The proportion of (XIII) and (XIV) in each case was about the same, i.e. 70% : 30%. Higher dilution with ether (1 l.-3 l per centimole of lithium aluminium hydride), longer reduction time (3-6 hr.) and lower reduction temperatures (ether reflux - 0°C) did not affect the yield or the proportion of the products significantly.

(4) Two equivalents of the butane-2,3-diol-lithium aluminium hydride complex to one equivalent of 1-tetra-

hydropyranyloxy-hex-2-yn-4-en-6-ol (IX) in ether also gave the mixture of (XIII) and (XIV) and recovered enynol (IX).

(5) Reduction with three equivalents of lithium aluminium hydride -3-O-benzyl-1,2-cyclohexylidene-D-glucofuranose complex^{130C} to one equivalent of the enynol (IX) also gave the mixture of the volatile allenic and acetylenic alcohols (XIII) and (XIV). The distillation of the residue gave a high boiling product, the i.v. spectrum of which showed the presence of the starting en-yn-ol (IX) and an allenic compound (see I.R.No.62). But redistillation followed by i.r., g.l.c. and t.l.c. identification showed that the product contained the allenic and acetylenic alcohols (XIII) and (XIV) as well as the starting enynol (IX) and the recovered sugar.

δ -Chloro- γ -valerolactone

Traube and Lehman^{141,142} in 1901 prepared α -acetyl- δ -chloro- γ -valerolactone by the condensation of epichlorhydrin with ethyl acetoacetate.

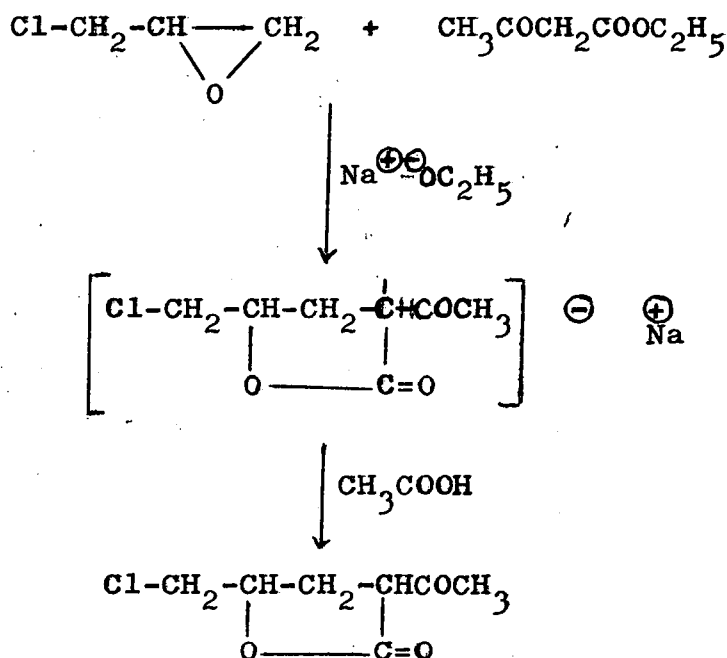

Our interest in the investigation of a possible route to the synthesis of the naturally occurring antibiotic Nemotin led us to consider the condensation of epichlorhydrin with diethyl malonate to yield α -carbethoxy- δ -chloro- γ -valerolactone (I) which might be converted to δ -formyl- γ -valerolactone (III) by the oxidation of the chloride (II) or its corresponding alcohol or via the intermediate (IV).

α -Carbethoxy- δ -chloro- γ -valerolactone (I) was prepared in 65% yield from the condensation of sodio-malonate and epichlorhydrin in absolute ethanol by the following steps:-

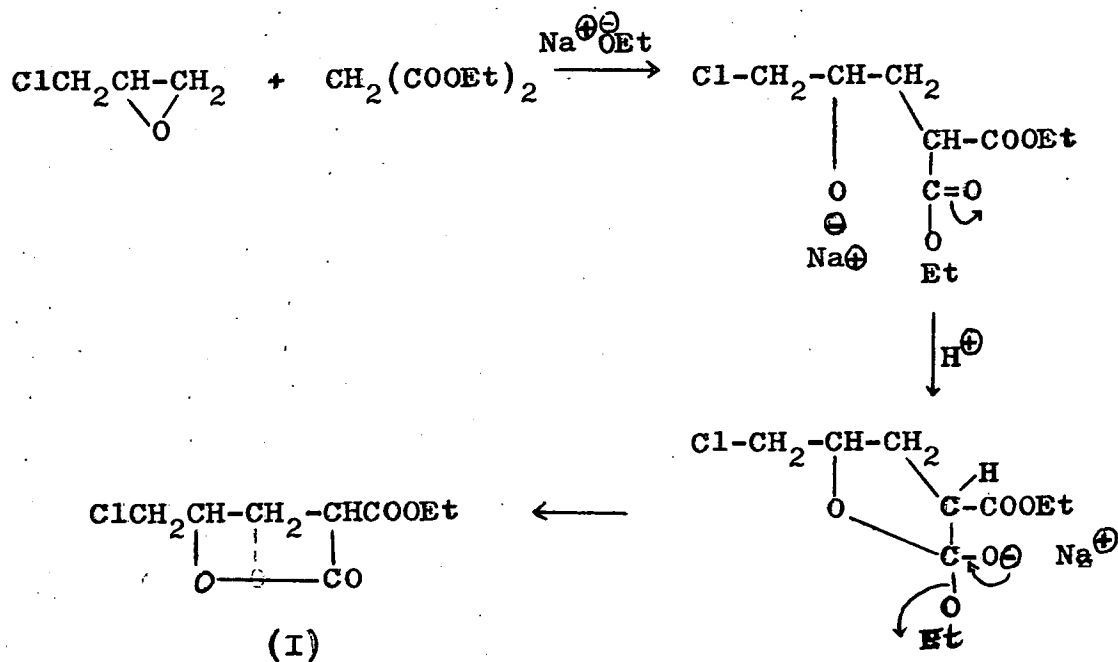

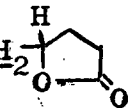
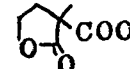
The chlor-lacton-ester (I) was identified by correct elemental analysis, a single peak on g.l.c., i.r. spectrum (showing ν_{max} 1780s (lactone) and 1725s (ester) cm^{-1} bands), and n.m.r. showing a doublet for the methylene protons (ClCH_2 ) at τ 6.24 ($J=5$ c./sec.), a quartet for the ester methylene protons () at τ 5.74 ($J=7$ c./sec.) and a triplet for the ester methyl protons

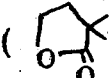
( CCOC(=O)C1CC(Cl)O1) at τ 8.68 ($J=7$ c./sec.) (see N.m.r.No.4).

Oxidations of chloro- and iodoparaffins to aldehydes in 60-75% yield by heating the halides to 150° with dimethyl sulphoxide and anhydrous potassium carbonate has been reported in the literature^{143,144,145}. This method proved unsuccessful for the chlor-lacton-ester (I) as well as iodo-lacton-ester (prepared from the chloride from sodium iodide and acetone¹⁴⁶). A modification of this method¹⁴⁷ in which the chloride is converted to its p-toluenesulphonate and the latter heated in dimethyl sulphoxide, also did not produce the required aldehyde (IV).

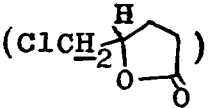
α -Carbethoxy- δ -chloro- γ -valerolactone (I) was converted to δ -chloro- γ -valerolactone (II) by refluxing the ester in concentrated hydrochloric acid for 24 hr. A 35-40% yield of the lactone was obtained, together with a polymeric material. The lactone had an i.r. spectrum similar to γ -butyrolactone (see I.R. Nos.68 and 69), and gave correct elemental analysis. N.m.r. showed a doublet for the methylene protons () at τ 6.42 and a multiplet for the other methylene protons at τ 7.6 similar to those of γ -butyrolactone (see N.m.r.

Nos. 5 and 6) and absence of the ester protons⁷. G.l.c. gave a single peak.

A literature survey showed that this simple chloro lactone (II) has never been made to date. The oxidation of δ -chloro- γ -valerolactone has not yet been attempted.

(iii)

EXPERIMENTAL

EXPERIMENTAL

Infra-red (i.r.) spectra were determined with a Perkin-Elmer Infracord spectrophotometer, the strength of the i.r. absorption bands have been abbreviated to vs (very strong), s (strong), m (medium), w (weak) and vw (very weak); ultra-violet (u.v.) spectra were determined with a Baush and Lomb Spectronic 505 spectrometer; nuclear magnetic resonance (n.m.r.) spectra were determined with a Perkin-Elmer and Varian 60 Ms/sec. spectrometer for approximately 20% solutions in carbon tetrachloride with tetramethyl silane as internal standard; and gas liquid chromatography (g.l.c.) was carried out with a Griffin and George instrument using 6 ft. glass columns with 10% silicone-oil/celite and N₂ flow rate 2 l./hr. unless otherwise stated.

Dimethyl sulphoxide was dried and distilled from calcium hydride and N,N-dimethylformamide was azeotropically distilled from benzene. The other solvents in parenthesis designated "dry" were dried with sodium (ether, benzene and tetrahydrofuran) and potassium hydroxide (pyridine) unless otherwise specified.

Melting point determinations were made on a micro-Kofler block.

3-Methyl-oct-1-yn-3-ol

Sodium (46.0 g., 2 moles) was added to liquid ammonia (4 l.) and a catalytic quantity of ferric nitrate (ca. 0.1 g.) in a well-lagged 5 l. flask. After about a quarter of the sodium had been added, dry acetylene was passed and the addition of the rest of sodium continued with stirring. After the addition of sodium (ca. 1 hr.) the ammonia solution was stirred and the passage of acetylene continued until the blue coloration changed to greyish-white (ca. 4 hr.) when methyl amyl ketone (228.4 g., 2 moles) previously cooled to -40° was added to the ammonia solution over 15 min. The rate of passage of acetylene was reduced and the solution stirred for another 4 hr., decomposed slowly with solid ammonium chloride (107 g., 2 moles), excess ammonia allowed to evaporate, the residue washed with ether (3 x 250 ml.), dried ($MgSO_4$), filtered, ether evaporated and the residue distilled at reduced pressure to give 3-methyl-oct-1-yn-3-ol, b.p. $50^{\circ}/1$ mm. (228.0 g., 82%) (Found: C, 77.2, H, 11.4, $C_9H_{16}O$ requires C, 77.1; H, 11.4%), D_{max}^{25} 3400s (-OH), 3300s ($C\equiv CH$), 2120w ($C\equiv CH$) cm^{-1} ; g.l.c. (silicone oil) at 98° , N_2 , 2 l./hr. gave a single peak (t, 21 min.).

3-Ethyl-pent-1-yn-3-ol

Similarly prepared from sodium (46.0 g., 2 moles), liquid ammonia (4 l.), ferric nitrate (0.1 g.) and diethyl ketone (172.3 g., 2 moles) to give b.p. 48-50°/15 mm. (146 g., 65%), \mathcal{D}_{\max} 3400s (-OH) 3300s (C≡CH), 2120w (C≡CH) cm.⁻¹; g.l.c. (silicone oil) at 84°, N₂ 2 l./hr. gave a single peak (t, 14 min.).

3,4,4-Trimethyl-pent-1-yn-3-ol:

Similarly prepared from sodium (46.0 g., 2 moles), liquid ammonia (4 l.), ferric nitrate (0.1 g.) and pinacolone (200.4 g., 2 moles) to give some recovered pinacolone and 3,4,4-trimethyl-pent-1-yn-3-ol, b.p. 64-66°/15 mm. (126 g., 50%), \mathcal{D}_{\max} 3400s (-OH), 3300s (C≡CH), 2120w (C≡CH) cm.⁻¹; g.l.c. (silicone oil) at 100°, N₂ 2 l./hr. gave a single peak (t, 10 min.).

3-Methyl-penta-1,2-diene

3-Methyl-pent-1-yn-3-ol (98.1 g., 1 mole) was added to concentrated hydrochloric acid (1 l.), and the mixture shaken in a 2 l. separating funnel. Periodically the upper organic phase was checked in the i.r. for hydroxyl band (3400 cm.⁻¹), and the shaking continued until the hydroxyl band could not be detected (ca. 15 min.). The

organic layer was separated and dried with anhydrous potassium carbonate. The crude material (110 g., 95%) showed ν_{\max} 3300s ($C\equiv CH$), 2120vw ($C\equiv CH$), 1950w ($C=C=C$) and 850b ($C=C=CH_2$) cm^{-1} indicating a mixture of 3-chloro-3-methyl-pent-1-yne and 1-chloro-3-methyl-penta-1,2-diene. G.l.c. (silicone oil) at 77° , N_2 2.2 l./hr. gave two components: t, 13 min. (65%, 3-chloro-3-methyl-pent-1-yne) and t, 15 min. (35%, 1-chloro-3-methyl-penta-1,2-diene). Further shaking with concentrated hydrochloric acid (500 ml.) and drying (K_2CO_3) gave the same ratio on g.l.c.

Zinc-copper couple was prepared by washing zinc dust (78 g., 1.25 mole) with distilled water (2 x 50 ml.), 3% hydrochloric acid (2 x 50 ml.), distilled water (3 x 50 ml.), 2% copper sulphate solution (2 x 50 ml.), distilled water (2 x 50 ml.), absolute ethanol (3 x 50 ml.), carefully decanting the liquids immediately after each wash and finally pouring the zinc-copper couple with a last aliquot of absolute ethanol (100 ml.) into a 250 ml. 3-neck flask equipped with a mechanical stirrer, dropping funnel and a downward distillation set-up. The ethanol was heated to its reflux temperature, the heating source

removed and the dry chloride added to the well-stirred suspension at such a rate as to bring about a gentle distillation of the alcohol-allene azeotrope at b.p. 72-78°. After the addition of the chloride, the mixture was heated and the distillation continued until the temperature of the azeotrope began to rise above 80°. The distillate was washed with water (250 ml.), dried (MgSO₄) and distilled to give 3-methyl-penta-1,2-diene, b.p. 74-76°/740 mm. (53.3 g., 65%), $\bar{D}_{\max}^{3300\text{vw}}$ (C≡CH), 1950s (C=C=C), 850s (C=C=CH₂) cm.⁻¹; g.l.c. (silicone oil) at 17°, N₂ 2.2 l./hr. gave a minor component at t, 10 min. (5%) and a major component at t, 12 min. (95%).

3-Methyl-buta-1,2-diene

Was prepared from 3-methyl-but-1-yn-3-ol (84.1 g., 1 mole), concentrated hydrochloric acid (12.) and zinc-copper couple (from 78 g., 1.25 moles of zinc and 100 ml. 2% copper sulphate solution) in absolute ethanol (100 ml.)], b.p. 39-40°/740 mm. (40.8 g., 60%), $\bar{D}_{\max}^{3300\text{vw}}$ (C≡CH), 1950s (C=C=C), 850s (C=C=CH₂) cm.⁻¹; g.l.c. (silicone oil) 17°, N₂ 2.2 l./hr. gave a minor component at t, 5 min. (5%) and a major component at t, 8 min. (95%).

3-Ethyl-penta-1,2-diene

Similarly prepared from 3-ethyl-pent-1-yn-3-ol (56.0 g., 0.5 mole), concentrated hydrochloric acid (700 ml.) and zinc-copper couple (from 39 g., 0.6 mole zinc and 50 ml 2% copper sulphate solution) in absolute ethanol (60 ml.) The product was washed with 5% ammonical silver nitrate solution (2 x 50 ml.), filtered and distilled to give b.p. 94-96°/740 mm. (27.0 g., 56%) (Found: C, 86.9; H, 12.7. C_7H_{12} requires C, 87.4; H, 12.6%), \bar{D}_{max} (I.R.1) 1950s (C=C=C), 850s (C=C=CH₂) cm^{-1} ; g.l.c. (polypropylene sebacate) at 20°, H₂ 8 atmospheres gave a single peak (t, 7 min.).

3,4,4-Trimethyl-penta-1,2-diene

Similarly prepared from 3,4,4-trimethyl-pent-1-yn-3-ol (63.0 g., 0.5 mole), concentrated hydrochloric acid (700 ml.) and zinc-copper couple (from 39 g., 0.6 mole Zn/Cu and 50 ml. EtOH. The product was washed with 5% ammonical silver nitrate solution (2 x 50 ml.), filtered and distilled to give b.p. 86-88°/740 mm. (30.2 g., 55%) (Found: C 86.9; H, 12.7; C₈H₁₄ requires C, 87.2; H, 12.7%), \bar{D}_{max} (I.R.3) 1950s (C=C=C) 850s (C=C=CH₂) cm^{-1} ; g.l.c. (polypropylene sebacate) at 22°^P, H₂ 8 atmospheres gave a single peak (t, 10 min.).

3-Methyl-Octa-1,2-diene

Similarly prepared from 3-methyl-oct-1-yn-3-ol (57.1 g., 0.5 mole), concentrated hydrochloric acid (700 ml.) and zinc-copper couple (from 39.0 g., 0.6 mole zinc and 50 ml. 2% copper sulphate solution) in absolute ethanol (60 ml.). The azeotrope distilled at 100-120°/740 mm. and several washings with water and ammoniacal silver nitrate solution gave b.p. 138-140°/740 mm. (27.9 g., 45%), \mathcal{D}_{\max} (I.R.), 1950s (C=C=CH₂), 850s (C=C=CH₂) cm.⁻¹; g.l.c. (silicone oil) at 80°N₂ 2 l./hr. gave a single peak (t, 8 min.).

Hexa-1,2-diene

Freshly redistilled thionyl chloride (120 g., 1 mole) was added dropwise over 1 hr. to an ice-cooled mixture of hex-1-yn-3-ol (97.1 g., 1 mole) dissolved in dry pyridine (80 g., 1 mole). After the addition, the mixture was stirred at room temperature for 1 hr. washed with 20% hydrochloric acid (3 x 50 ml.), water (2 x 50 ml.) and dried (K₂CO₃). The crude chloride was reduced with zinc-copper couple (prepared from 78 g., 1.25 mole of zinc and 100 ml. 2% copper sulphate solution) in absolute ethanol (100 ml.) to give b.p. 70-72°/740 mm. (41.0 g., 50%), \mathcal{D}_{\max} 3300w (C≡CH),

1950s ($C=C=C$), 850s ($C=C=CH_2$) $cm.^{-1}$; g.l.c. (polypropylene sebacate) at 20° , H_2 8 atmospheres gave a minor component (t, 4 min., 2%) and a major component (t, 5 min., 98%).

1-1-Dichloro-2,2-dimethyl-3-methylenecyclopropane

Potassium metal (4 g., 0.1 atom) was added in small pieces to dry t-butanol (150 ml.) and the mixture refluxed until the potassium had completely dissolved. Excess alcohol was distilled off, the last traces under reduced pressure, and the white solid powdered, washed with sodium dried benzene (3 x 50 ml.), the benzene syphoned off, washed with dry pentane, the solvents removed in vacuo, and the solid dried in vacuo at 100° for 2 hr. 3-Methyl-buta-1,2-diene (6.8 g., 0.1 mole) and dry pentane (10 ml.) were added to the solid, the mixture cooled in an ice-salt bath, and chloroform (12 g., 0.1 mole) was added dropwise to the rapidly stirred mixture over 1 hr. After the addition, the mixture was stirred for 1 hr. at 0° , 1 hr. at room temperature, poured into ice-water and extracted with pentane (3 x 50 ml.), dried ($MgSO_4$), filtered, solvents removed, and distilled yielding crude product, b.p. $65-68^\circ/80$ mm. (7.4 g., 49%).

Redistillation gave the pure 1,1-dichloro-2,2-dimethyl-3-methylenecyclopropane, b.p. 65-68°/80 mm. (6.3 g., 41%). G.l.c. (10% apiezon-celite) at 70°, N₂ 1.8 l./hr. gave a single component (t, 8 min.) (Found: C, 47.4; H, 5.1; Cl, 46.9; C₆H₈Cl₂ requires C, 47.7; H, 5.3; Cl, 46.9%), ν_{\max} (I.R.4) 1820w, 1750w (overtone), 1010m (cyclopropane), 910s (C=CH₂) and 865s cm.⁻¹, λ_{\max} 205m μ (ϵ , 5,200), λ_{sh} 234 m μ (ϵ , 500). The product (1 g.) in anhydrous ether (30 ml.) with Adam's platinum catalyst (0.024 g.) absorbed 94.5 ml. of hydrogen (one molar equivalent requires 99.9 ml.) in ten minutes and showed little further absorption after one hour's shaking. The catalyst was filtered off, ether evaporated, and the residue distilled, b.p. 46-48°/90 mm., and found to have a superimposable, infra-red spectrum with that of an authentic sample of 1,1-dichloro-2,2,3-trimethylcyclopropane.¹⁴

Ozonolysis of the product (0.8 g.) in dry ethyl acetate (50 ml.) followed by hydrogenolysis (PtO₂, 0.032 g.) and distillation gave formaldehyde as its dimedone derivative (0.25 g.) m.p. and m.m.p. 189.5°.



N.m.r. showed two non-equivalent protons for the exocyclic methylene group ($\begin{array}{c} \text{C} \\ \diagup \quad \diagdown \\ \text{H} \quad \text{H} \end{array}$) at τ 4.12 and τ 4.48,

1,1-Dichloro-2-ethyl-2-methyl-3-methylenecyclopropane

Dry potassium t-butoxide (prepared from potassium 4 g., 0.1 g. atom and t-butanol, 150 ml.) was covered with 3-methyl-penta-1,2-diene (8.2 g., 0.1 mole) in dry pentane (10 ml.) in an ice-salt bath and chloroform (12 g., 0.1 mole) added dropwise over 1 hr. The mixture was stirred for 1 hr. at 0°, 1 hr. at room temperature, poured into ice-water and extracted with pentane (3 x 50 ml.), dried (MgSO₄), filtered and distilled yielding 1,1-dichloro-2-ethyl-2-methyl-3-methylenecyclopropane (8.3 g., 50%), b.p. 70°/90 mm. (Found: C, 50.8; H, 6.1; Cl, 42.9, C₇H₁₀Cl₂ requires C, 50.9; H, 6.2; Cl, 42.0%), ν_{\max} (I.R.5) 1820w, 1720w, 1625m (overtone), 1002m (cyclopropane), 910s (>C=CH₂), and 865s cm.⁻¹, λ_{\max} (U.V.1) 206 m μ (ϵ , 5,250), λ_{sh} 234 m μ (ϵ , 500). G.l.c. (apiezon) at 70°, N₂ 1.8 l/hr. gave a single component (t, 17 min.)

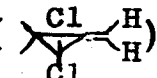
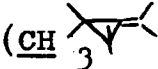
The product (0.9 g.) in ethyl acetate (20 ml.) with Adam's platinum oxide catalyst (0.042 g.) absorbed 74 ml. hydrogen (theoretical requirement 79 ml.) in 15 min.

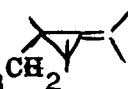
N.m.r. showed two non-equivalent protons for the exocyclic methylene group () at τ 4.17 and 4.51, a singlet for the methyl protons () at τ 8.61, a

triplet for the methyl protons (CH_3CH_2 ) at τ 8.94 ($J=6.5$ c./sec.) and a quartet for the methylene protons (CH_3CH_2 ) at τ 8.27 ($J=6.5$ c./sec.).

Ozonolysis of dichloro-2-ethyl-2-methyl-3-methylenecyclopropane (0.8 g.) in dry ethyl acetate and hydrogenolysis (PtO_2 , 0.032 g.) and distillation at 40° gave formaldehyde as the dimedone-derivative (0.26 g.) m.p. 189.5° . A mixed m.p. with an authentic sample prepared from formaldehyde showed no depression.

1,1-Dibromo-2-ethyl-2-methyl-3-methylenecyclopropane

Dry potassium t-butoxide (from potassium 7.6 g., 0.19 g., atom and t-butyl alcohol, 150 ml.) was covered with 3-methylpenta-1,2-diene (15 g., 0.19 mole) at 0° and bromoform (48.0 g., 0.19 mole) was added dropwise over 30 min. with stirring. At the end of the addition the flask was warmed to room temperature and stirred for 1 hr. The reaction mixture was poured onto ice-water and extracted with ether (3 x 100 ml.), dried (MgSO_4) and distilled, yielding 1,1-dibromo-^{-2-ethyl}2-methyl-3-methylenecyclopropane (22 g., 58%), b.p. $49-50^\circ/2$ mm. D_{max} (I.R. 11) 1820w, 1750w, 1040m (cyclopropane) 905s (>C=CH_2) and 800s cm.^{-1} , λ_{max} 207 μ (ϵ , 5,300),

λ sh. 225 $m\mu$ (ξ , 3000). G.l.c. (dinonylphthalate) at 140° , N_2 1.8 l./hr. showed one component (t, 15 min.).

1,1-Dichloro-2-pentyl-2-methyl-3-methylenecyclopropane

Dry potassium t-butoxide (from potassium 4 g., 0.1 g. atom, and t-butanol, 150 ml.) was covered with 3-methyl-octa-1,2-diene (12.4 g., 0.1 mole) and dry pentane (10 ml.), and chloroform (12.0 g., 0.1 mole) was added dropwise to the stirred mixture. The mixture was stirred for 1 hr. at 0° , 1 hr. at room temperature, poured into ice-water and extracted with pentane (3 x 50 ml.), dried ($MgSO_4$) and distilled, yielding ^{1,1-dichloro-}2-pentyl-2-methyl-3-methylenecyclopropane (14.5 g., 36%), b.p. 64-65/70 mm. (Found: C, 57.7; H, 7.6; Cl, 34.2%; $C_{10}H_{16}Cl_2$ requires C, 58.0; H, 7.8; Cl, 34.3%), ν_{max} (I.R. 8) 1820w, 1730w (overtone), 1640w, 1012m (cyclopropane), 910s ($>C=CH_2$) and 865s cm^{-1} .

1,1-Dichloro-2,2-diethyl-3-methylenecyclopropane

Dry potassium t-butoxide (from potassium 4.0 g., 0.1 g. atom and t-butanol, 150 ml.) was covered with 3-ethyl-penta-1,2-diene (9.6 g., 0.1 mole) and dry pentane (10 ml.), and chloroform (12.09, 0.1 mole) was added dropwise with vigorous stirring over 1 hr; stirring was continued for 1 hr. at 0° , 1 hr. at room temperature and the mixture poured onto ice-water, extracted with pentane (3 x 50 ml.), dried ($MgSO_4$) and distilled

yielding 1,1-dichloro-2,2-diethyl-3-methylenecyclopropane, 62-64°/70 mm. (10.0 g., 54%) (Found: C, 53.1; H, 6.6; Cl, 39.0; $C_8H_{12}Cl_2$ requires C, 53.6; H, 6.7; Cl, 38.6%), $\bar{\nu}_{max}$ (I.R.6) 1820w, 1720w (overtones), 1002m (cyclopropane), 910s (>C=CH_2) and 865s cm^{-1} ; g.l.c. (silicone oil) at 76°, N_2 2 l./hr. gave a single peak (t, 20 min.).

1,1-Dibromo-2,2-diethyl-3-methylenecyclopropane

Dry potassium t-butoxide (prepared from potassium, 4 g., 0.1 atom, and t-butanol, 150 ml.) was covered with 3-ethyl-penta-1,2-diene (8.2 g., 0.1 mole) and pentane (10 ml.), and bromoform (25.3 g., 0.1 mole) was added dropwise over 1 hr. with stirring, the mixture stirred for 1 hr. at 0°, 1 hr. at room temperature, poured onto ice-water, extracted with ether (3 x 50 ml), dried ($MgSO_4$) and fractionated, yielding 1,1-dibromo-2,2-diethyl-3-methylenecyclopropane (19.5 g., 73%), b.p. 64-65°/3 mm. (Found: C, 35.9; H, 4.3; Br, 59.0; $C_8H_{12}Br_2$ requires C, 35.8; H, 4.4; Br, 59.8%), $\bar{\nu}_{max}$ (I.R.12) 1820w, 1750w, 1060m (cyclopropane), 905s (>C=CH_2) and 800s cm^{-1} ; λ_{max} 210 $m\mu$ (ϵ , 5,760); g.l.c. (polypropylene sebacate) at 110°, H_2 8 atmospheres gave a single peak (t, 19 min.).

1,1-Dichloro-2-methyl-2-t-butyl-3-methylenecyclopropane

Dry potassium t-butoxide (from potassium 4 g., 0.1 g. atom and t-butanol, 150 ml.) was covered with 3-methyl 4,4-dimethyl-penta-1,2-diene (11.0 g., 0.1 mole) and pentane (10 ml.) at 0° and chloroform (12.0 g., 0.1 mole) was added dropwise over 1 hr. with stirring, the mixture stirred for 1 hr. at 0°, 1 hr. at room temperature, poured onto ice water, extracted with ether (3 x 50 ml), dried (MgSO₄) and fractionated, yielding 1,1-dichloro-2-methyl-2-t-butyl-3-methylenecyclopropane (9.76 ⁵¹~~g.~~%), b.p. 78-80°/65 mm. (Found: C, 55.7; H, 7.0; Cl, 36.4; C₉H₁₄Cl₂ requires C, 55.9; H, 7.2; Cl, 36.8%), ν_{\max} (I.R.) 1820w, 1750w (overtone), 1010m. (cyclopropane), 910s (C=CH₂) and 865 cm.⁻¹; g.l.c. (silicone oil) at 84°, N₂ 2 l./hr. gave a single peak (t, 11 min.).

1,1-Dichloro-2-n-propyl-3-methylenecyclopropane

Dry potassium t-butoxide (from potassium 4 g., 0.1 g. atom and t-butanol, 180 ml.) was covered with hexa-1,2-diene (8.2 g., 0.1 mole) and dry pentane (10 ml.) at 0° and chloroform (12 g., 0.1 mole) was added dropwise over 1 hr. with stirring, the mixture stirred for 1 hr. at 0°, 1 hr. at room temperature, poured onto ice-water,

extracted with ether (3 x 50 ml.), dried (MgSO_4) and fractionated, yielding 1,1-dichloro-2-n-propyl-3-methylenecyclopropane (7.8 g., 47%), b.p. 66-68°/100 mm. (Found: C, 50.8; H, 6.1; Cl, 42.9; $\text{C}_7\text{H}_{10}\text{Cl}_2$ requires C, 50.9; H, 6.2; Cl, 42.0%), \mathcal{D}_{max} (I.R.7) 1820w, 1720w (overtone), 1038m (cyclopropane), 912s (>C=CH_2) and 760m cm.^{-1} ; g.l.c. (silicone oil) at 70°, N_2 1./hr. gave a single band (t, 15 min.). N.m.r. showed two non-equivalent doublets () at γ 4.07.

Reaction of dihalocarbenes with 1-bromoallene

I. (i) A solution of 1-bromo-3-methyl-penta-1,2-diene (16.1g., 0.1 mole) in chloroform (12.0 g., 0.1 mole) was added dropwise over 1 hr. to a well-stirred suspension of potassium t-butoxide (from 4.0g. 0.1 mole potassium and t-butanol, 150 ml.) in dry pentane (25 ml.) cooled to 0° in ice. The reaction temperature was maintained at 0° throughout the addition, and the mixture stirred at 0° for 1 hr., room temperature for 1 hr., poured into water, extracted with pentane (50 ml x 2), dried (MgSO_4), and distilled to give b.p. 78-82°/50 mm. (13.5 g., 85%). The product on g.l.c. (silicone oil) at 80°, N_2 2 l./hr. gave a single peak (t, 14 min.) identified as 1-bromo-3-methyl-penta-1,2-diene, \mathcal{D}_{max} 1950ws

(C=C=C), 1165vs and 730vs cm.^{-1} .

(ii) Bromoform (25.3 g., 0.1 mole) also gave the recovered bromoallene (11.0 g., 69%) under the same conditions as (i).

(iii) Similarly excess chloroform (47 g., 0.4 mole) likewise gave the recovered bromoallene (12.5, 77%).

II. To a suspension of sodium trichloroacetate (14.9 g., 0.8 mole $\bar{\square}$ prepared by the addition of trichloroacetic acid (21.3 g., 0.13 mole) to sodium ethoxide (8.8 g., 0.13 mole), filtering the solid, washing with chloroform (3 x 50 ml.) and drying at $40-50^{\circ}/1\text{mm.}\bar{\square}$ in freshly distilled (from calcium hydried) dimethoxy ethane (100 ml.) was added 1-bromo-3-methyl-penta-1,2-diene (8.0 g., 0.05 mole), the mixture heated at 150° for 3 hr. under dry N_2 , added to water (200 ml.), extracted with ether (3 x 50 ml.), dried (MgSO_4), and distilled to give the recovered allene bromide (4.0 g., 50%) identified by i.r. and g.l.c. as in (i).

III. 1-Bromo-3-methyl-penta-1,2-diene (0.8 g., 0.01 mole) in dry benzene (10 ml.) was added to tribromethyl-

phenyl-mercury (11.7 g., 0.022 mole) $\overline{\text{pre}}\overline{\text{pared}}$ from phenyl-mercury-bromide (17.9 g., 0.05 g.,) potassium t-butoxide (5.6 g., 0.05 mole) and bromoform (12.7 g., 0.05 mole) in dry benzene (40 ml.)¹⁴⁸ and the mixture refluxed for 3 hr., poured into water (100 ml.), benzene layer separated, the aqueous layer extracted with ether (2 x 25 ml.), the combined organic layer washed with water (2 x 50 ml.), dried (MgSO_4) and distilled to give the recovered allene bromide (5.6 g., 70%) identified by i.r. and g.l.c. as in (i).

1,3-Dibromo-prop-1-yne

Bromine (40.0 g., 0.4 mole) was added dropwise with stirring to 1 N potassium hydroxide solution (1 l.) at 0°, the temperature being maintained at 0° throughout the addition. 3-Bromo-prop-1-yne (48.0 g., 0.4 mole) was added in one portion to the well-stirred mixture at 0°, stirred at 0° for 1 hr. and allowed to reach room temperature. The lower organic layer separated, the upper aqueous layer extracted with ether (2 x 50 ml), the combined organic layer dried (MgSO_4) and ether evaporated on a rotary evaporator to yield a fuming amber liquid (79.0 g., theoretical)¹⁴⁷, D_{max} (I.R.65)

3020w (C-H), 2260s (-C≡C-), 1420w, 1210vs, 1064m and 860 cm.⁻¹; g.l.c. (apiezon L) at 82°, N₂ @ 1./hr. gave a single peak (t, 14 min.). Distillation gave a fuming colourless liquid (64.0 g., 81%), b.p. 50-54°/10 mm. (Found: C, 18.4; H, 1.2; Br, 80.4; C₃H₂Br₂ requires C, 18.2; H, 1.0; Br, 80.7%), i.r. and g.l.c. identical with the undistilled product identified as 1,3-dibromo-prop-1-yne. N.m.r. (N.m.r.10) showed only a sharp singlet for the methylene protons at τ 6.10

Cumulenes4-Methyl-penta-1,2,3-triene:

(a) A solution of 1,1-dibromo-2,2-dimethyl-3-methylene-cyclopropane (12.0 g., 0.05 mole) in 25 ml. ether was added dropwise over 15 min. to *n*-butyl-lithium (from lithium wire, 0.6 g., 0.1 g. atom, *n*-butyl bromide, 6.8 g., 0.05 mole) at -40° , the temperature being maintained below -30° . The mixture was stirred for 15 min. at -30° , and slowly allowed to warm up to room temperature. Distillation in vacuo gave a product which was collected in a cold trap (-30 – -40°) and redistillation under nitrogen at atmospheric pressure gave 4-methylpenta-1,2,3-triene, b.p. 56 – 58° containing ether; g.l.c. (silicone oil) at 21° , H_2 at 9 atmosphere, ~~it~~ gave two peaks: t, 3 min. (50%, ether) and 9 min. (50%, cumulene). The yield of cumulene by g.l.c. was ca. 3 g., 75%, ν_{\max} (I.R.13) 2080s (C=C=C=C), 820b cm^{-1} ; λ_{\max} (in hexane) 220 μ (ϵ , 3,500), 254 μ (ϵ , 13,000), 294 μ (ϵ , 700). The product (ca. 0.5 g., 0.006 mole) in ether over a catalyst (PtO_2 , 0.158 g.) absorbed hydrogen (530 ml., 0.023 mole). Distillation gave 2-ethylpentane (b.p. 60°) in ether identified by comparing with an authentic sample on g.l.c. (silicone oil), 16° , N_2 2 l./hr., t 9 min.) and i.r. spectra.

(b) Using the same procedure 1,1-dichloro-2,2-dimethyl-3-methylenecyclopropane (3.8 g., 0.025 mole) and n-butyl lithium (from lithium wire 0.3 g., 0.05 g. atom and n-butyl bromide 3.4 g., 0.025 mole) gave 4-methylpenta-1,2,3-triene (1.4 g., 70%).

4-Methylhexa-1,2,3-triene

(a) A solution of 1,1-dibromo-2-methyl-2-ethyl-3-methylenecyclopropane (12.7 g., 0.05 mole) in 25 ml. ether was added dropwise over 15 min. to n-butyl lithium (from lithium wire 0.6 g., 0.1 g. atom and ~~dry~~ n-butyl bromide (6.9 g., 0.05 mole) in 10 ml. of ether at -40° the temperature being maintained below -30° . The mixture was stirred for 15 min. at -30° then slowly allowed to warm up to 30° , distilled in vacuo and the product collected in a cold trap (at -40°). Redistillation under nitrogen at atmospheric pressure gave 4-methylhexa-1,2,3-triene, b.p. $65-68^{\circ}$ containing ether. G.l.c. (silicone oil) at 22° , N_2 2 l./hr. gave two components: t, 3 min. (35%, ether) and t, 28 min. (65%, cumulene). The yield by g.l.c. was ca. 3.7 g., 75%, D_{\max} (I.R.14) 2080m ($C=C=C$) $820b\text{ cm.}^{-1}$; λ_{\max} 218 m ($\xi, 7,750$), 256 μ ($\xi, 16,200$), 294m ($\xi, 900$). The product (1 g., 0.012 mole) in ether

over catalyst (PtO_2 , 0.140 g.) absorbed hydrogen (595 ml. 0.27 mole). Distillation gave 3-methylhexane identified by comparison with an authentic sample on g.l.c. (silicone oil, 16° , N_2 2 l./hr., t 27 min.) and i.r. spectra.

(b) Using the same procedure 1,1-dichloro-2-methyl-2-ethyl-3-methylenecyclopropane (4.1 g., 0.025 mole) and *n*-butyl lithium (from lithium wire, 0.3 g., 0.05 g. atom and *n*-butyl bromide, 3.4 g., 0.025 mole) gave 4-methylhexa-1,2,3-triene (1.8 g., 73%).

4-Ethylhexa-1,2,3-triene

(a) A solution of 1,1-dibromo-2,2-diethyl-3-methylenecyclopropane (13.4 g., 0.5 mole) in 25 ml. ether was added dropwise over 15 min. to *n*-butyl lithium (from lithium wire 0.6 g., 0.1 g. atom and ~~dry~~ *n*-butyl bromide (6.9 g. 0.025 mole) in 10 ml. of ether at -40° , the temperature being maintained below -30° . The mixture was stirred for 15 min. at -30° then slowly allowed to warm up to room temperature. Distillation in vacuo gave a product which was collected in a cold trap (at -40°). Redistillation under nitrogen at atmospheric pressure gave 4-methylhexa-1,2,3-triene, b.p. $82-84^\circ$ containing ether. G.l.c. (silicone oil) at 22° , N_2 2 l./hr. gave two components:

t, 3 min. (25%, ether) and t, 35 min. (75%, cumulene). The yield by g.l.c. was ca. 3.7 g., 75%, D_{\max} (I.R.15), 2080m ($\text{C}=\text{C}=\text{C}=\text{C}$), 820b cm.^{-1} , λ_{\max} (U.V.3) 218 $\text{m}\mu$ (ξ , 16,000), 294 $\text{m}\mu$ (ξ , 900).

(b) Using the same procedure 1,1-dichloro-2,2-diethyl-3-methylenecyclopropane (6.7 g., 0.025 mole) and n-butyl lithium (from lithium wire, 0.3 g., 0.05 g. atom and n-butyl bromide, 3.4 g., 0.025 mole) gave 4-methylhexa-1,2,3-triene (1.6 g., 75%).

Cope Rearrangement of Propargyl Alkenyl Malonates

Diethyl isobutylidenemalonate.

Method A: Diethyl malonate (80.0 g., 0.50 mole), freshly distilled isobutyraldehyde (39.6 g., 0.55 mole), piperidine (1.7 g., 0.02 mole), glacial acetic acid (6.0 g., 0.1 mole) and dry benzene (50 ml.) were refluxed using a Dean and Stark constant water separator until the theoretical volume of water had been separated (ca. 3 hr.) The mixture was allowed to cool to room temperature, washed with water (3 x 100 ml.), benzene layer separated, aqueous layer extracted with benzene (2 x 50 ml.), the organic layers combined, dried ($MgSO_4$) and distilled to give diethyl isobutylidenemalonate, b.p. 128-130°/23 mm. (92.0 g., 90%), $\bar{\nu}_{max}$ (I.R.46) 1740s ($\bar{\nu}_{C=O}$), 1650s ($\bar{\nu}_{C=C}$) cm^{-1} , λ_{max} 209 $m\mu$ ($\xi, 13,020$); g.l.c. (silicone oil) at 150° N_2 2.6 l/hr. gave a single peak (t, 41 min.).

Diethyl n-butylidenemalonate

Method A using diethyl malonate (80.0 g. 0.50 mole), freshly distilled n-butyraldehyde (39.6 g., 0.55 mole), similarly gave diethyl n-butylidenemalonate b.p. 122-124°/10 mm. (59.0 g., 56%), $\bar{\nu}_{max}$ 1740s ($\bar{\nu}_{C=O}$), 1650s ($\bar{\nu}_{C=C}$)

cm.⁻¹, λ_{\max} 208 m μ (ξ , 11,200); g.l.c. (polypropylene sebacate) at 174°, H₂ 8 atmospheres gave a single peak (t, 8 min.). N.m.r. (N.m.r.19) showed two Quartets for the pair of non-equivalent ester methylene protons at γ 5.76 and 5.80 (J=7.2 c./sec. for each Quartet) and two triplets for the pair of ester methyl protons at γ 8.72 and 8.74 (J=7.2 c./sec. for each Quartet).

Diethyl benzylidenemalonate

Method A using diethyl malonate (80.0g., 0.5 mole), freshly redistilled benzaldehyde (55.0 g., 0.55 mole), piperidine (1.7 g., 0.02 mole) glacial acetic acid (6.0 g., 0.1 mole) and dry benzene (50 ml.) similarly gave diethyl benzylidenemalonate, b.p. 140-142°/0.1 mm. (115.0 g., 92%), ν_{\max} 1740s ($\text{C}=\text{O}$), 1650m ($\text{C}=\text{C}$), 1600m (aromatic) cm.⁻¹, λ_{\max} (U.V.8) 205 m μ (ξ , 21,650), 217 m μ (ξ , 17,140), λ_{sh} 221 m μ (ξ , 13,630), 280 m μ (ξ , 24,655). N.m.r. (N.m.r.21) showed two Quartets for the pair of non-equivalent ester methylene protons at γ 5.64 and 5.70 (J=7.2 c./sec. for each Quartet) and two triplets for the pair of non-equivalent ester methyl protons at γ 8.74 and 8.76 (J=7.2 c./sec. for each triplet).

Diethyl isopropylidenemalonate

Method B: Diethyl malonate (100.0 g., 0.625 mole)

acetone (54.0 g., 0.93 mole), freshly distilled acetic anhydride (80.0 g., 0.78 mole) and freshly fused zinc chloride (ca. 12 g.) were mixed and refluxed for 24 hr., after which the dark mixture was cooled, benzene (100 ml.) and water (200 ml.) added, the organic later separated, washed with water (2 x 100 ml.), dried (MgSO_4), benzene removed on the rotary evaporator and the residue distilled under reduced pressure to give a forerun, b.p. $20-104^\circ/20$ mm. consisting of the starting materials, and diethyl isopropylidenemalonate, b.p. $95-96^\circ/1.5$ mm. (70 g., 57%), $\bar{\nu}_{\text{max}}$ 1740s ($\text{C}=\text{O}$), 1650s ($\text{C}=\text{C}$) cm.^{-1} , λ_{max} 217.5 $\text{m}\mu$ (ξ , 11,990); g.l.c. (silicone oil) at 176° , N_2 2.8 l/hr. gave a single peak (t, 17 min.). N.m.r. (N.m.r. 16) showed a quartet for the equivalent pair of ester methylene protons at γ 5.80 ($J=7.2$ c./sec.) and a triplet for the equivalent pair of ester methyl protons at γ 8.68 ($J=7.2$ c./sec.)

Diethyl 1-methyl-n-propylidenemalonate

Method B using diethyl malonate (100.0 g., 0.625 mole), methyl ethyl ketone (86.0 g., 1 mole) freshly distilled acetic anhydride (80.0 g., 0.78 mole) and freshly fused zinc chloride (ca. 12 g.) similarly gave diethyl 1-methyl-propylidenemalonate, b.p. $100-104^\circ/2$ min. (80.0 g., 63%), $\bar{\nu}_{\text{max}}$ 1740s ($\text{C}=\text{O}$), 1650 ($\text{C}=\text{C}$) cm.^{-1} ; g.l.c. (silicone oil) at 174° , H_2 9 atmospheres gave a single peak (t, 15 min.).

Diethyl ethylidenemalonate

Method B using diethyl malonate (100.0 g., 0.625 mole), acetaldehyde (60.0 g., 1.4 mole), freshly distilled acetic anhydride (102.0 g., 1 mole) and freshly fused zinc chloride (ca. 12 g.), similarly gave diethyl ethylidenemalonate b.p. 98-100°/5 mm. (37.2 g., 32%), ν_{\max} 1740s (C=O), 1650s (C=C) cm.^{-1} , λ_{\max} 209.5 $\text{m}\mu$ (ξ , 12,750); g.l.c. (silicone oil) at 125°, N_2 2 l/hr. gave a single peak (t, 25 min.).

Diethyl n-propylidenemalonate

Method B using diethyl malonate (110.0 g., 0.7 mole), n-propionaldehyde (80.0 g., 1.4 mole), freshly distilled acetic anhydride (102.0 g., 1 mole) and freshly fused zinc chloride (ca. 12 g.) similarly gave diethyl n-propylidenemalonate b.p. 136-140°/45 mm. (40.0)g., ν_{\max} 1740s (C=O), 1650s (C=C), cm.^{-1} ; g.l.c. (polypropylene sebacate) at 150°, H_2 8 atmospheres gave a single peak. N.m.r. (N.m.r. 15) showed two quartets for the non-equivalent pair of ester methylene protons at γ 5.66 and 5.74 ($J=7.2$ c./sec. for each quartet), a triplet for the alkylidene proton ($-\text{CH}_2-\underset{\text{H}}{\text{C}}=\text{C}\begin{matrix} \diagup \text{COOEt} \\ \diagdown \text{COOEt} \end{matrix}$) at γ 2.94 ($J=8.4$ c./sec.) and two triplets of non-equivalent ester methyl protons at γ 8.68 and 8.72 ($J=7.2$ c./sec. for each triplet).

Diethyl isobutenylpropargylmalonate

Diethyl isobutylidenemalonate (25.6 g., 0.12 mole) was added dropwise to a stirred solution of sodium (2.8 g., 0.11 g. atom) in absolute ethanol (200 ml.), the mixture stirred for 30 min. at room temperature, then cooled to 0° and propargyl bromide (14.8 g., 0.124 mole) added over 15 min., the mixture stirred for 30 min. and left overnight at room temperature. Ether (150 ml.) and water (150 ml.) were added, the combined organic layer dried (MgSO_4) and distilled to give a forerun of unreacted diethyl isobutylidenemalonate followed by diethyl isobutenylpropargylmalonate (18.0 g., 60%), b.p. 90-92°/0.18 mm. (Found: C, 65.6; H, 8.2%; $\text{C}_{14}\text{H}_{20}\text{O}_4$ requires C, 66.6; H, 8.2%), Δ_{max} (I.R. 26) 3300 vs ($-\text{C}\equiv\text{CH}$), 2120 vs ($\text{C}\equiv\text{CH}$), 1740 vs ($\text{C}=\text{O}$), 1650 vs ($\text{C}=\text{C}$), 1360 vs and 1380 vs (CMe_2 doublet) cm.^{-1} ; g.l.c. (silicone oil) at 174°, N_2 2.8 l./hr. gave a single peak (t, 25 min.).

Diethyl ethenylpropargylmalonate

Diethyl ethylidene-malonate (18.8 g., 0.1 mole), sodium ethoxide [from sodium (2.3 g., 0.1 g. atom) in absolute ethanol (200 ml.)] and propargyl bromide (12.0 g., 0.1 mole) similarly gave diethyl ethenylpropargylmalonate

b.p. 130-132°/2.5 mm. (10.0 g., 45%). The distillate crystallized out upon cooling (m.p. 50.0°) (Found: C, 65.5; H, 7.2; $C_{12}H_{16}O_4$ requires C, 64.3; H, 7.2%), D_{\max} (I.R.20) 3300s ($C\equiv CH$), 1750s ($C=O$) cm^{-1} ; g.l.c. (silicone oil) at 132°, H_2 9 atmospheres gave a single peak (t, 20 min.).

Diethyl n-propenylpropargylmalonate

Diethyl n-propylidene malonate (40.0 g., 0.2 mole), sodium ethoxide [from sodium, (4.6 g., 0.2 g. atom) in absolute ethanol (200 ml.)] and propargyl bromide (24.0 g., 0.2 mole) similarly gave diethyl n-propenylpropargylmalonate b.p. 134-136°/1.5 mm. (24.0 g, 48%) (Found: C, 65.5; H, 7.2; $C_{13}H_{18}O_4$ requires C, 65.5; H, 7.5%) D_{\max} (I.R.21) 3300s ($C\equiv CH$), 2120w ($C\equiv CH$), 1740s ($C=O$), 1650m ($C=C$); g.l.c. (silicone oil) at 150°, N_2 2 l./hr. gave a single peak (t, 14 min.).

Diethyl isopropenylpropargylmalonate

Diethyl isopropylidenemalonate (45.0 g., 0.25 mole), sodium ethoxide [from sodium (5.8 g., 0.25 g. atom) in absolute ethanol (350 ml.)] and propargyl bromide (30.0 g., 0.25 mole), similarly gave diethyl isopropenylpropargylmalonate, b.p. 104-106°/1.5 mm. (30.0 g., 52%); g.l.c.

(silicone oil) at 178° , N_2 3 l./hr. gave a major component (t, 17 min., 80%) and a minor component (t, 26 min., 20%). Upon refrigeration, the distillate crystallized out (m.p. $48-49^{\circ}$ from ethanol) (Found: C, 65.1; H, 7.6; $C_{13}H_{16}O_4$ requires C, 65.3; H, 7.7%); D_{\max} (I.R.22) 3300s ($C\equiv CH$), 2120w ($C\equiv CH$), 1740s (>C=O), 1650m (>C=C<) cm^{-1} .

Diethyl n-butenylallylmalonate⁴⁴

Diethyl n-butyldenemalonate (21.8 g., 0.1 mole), sodium ethoxide $\overline{\Delta}$ from sodium (2.4 g., 0.1 g. atom) in absolute ethanol (200 ml.) $\overline{\Delta}$ and allyl bromide (12.0 g., 0.1 mole) similarly gave diethyl n-butenylallylmalonate b.p. 66-68 /10 mm. (14.0 g., 60%) D_{\max} 1740s (>C=O), 1650 (>C=C<) cm^{-1} ; g.l.c. (polypropylene sebacate) at 174° , H_2 9 atmospheres gave a major component (t, 11 min., 95%) and a minor contaminant (t, 8 min., 5%).

Diethyl n-butenylpropargylmalonate

Diethyl n-butyldenemalonate (21.8 g., 0.1 mole), sodium ethoxide $\overline{\Delta}$ from sodium (2.4 g., 0.1 g. atom) in absolute ethanol (200 ml.) $\overline{\Delta}$ and propargyl bromide (12.0 g., 0.1 mole) similarly gave diethyl n-butenylpropargylmalonate b.p. $130-132^{\circ}$ /10 mm. (12.8 g., 54%) (Found:

C, 66.1; H, 8.0%; $C_{14}H_{20}O_4$ requires C, 66.6; H, 8.2%;
 ν_{\max} (I.R. 18) 3300s ($C\equiv CH$), 2120w ($C\equiv CH$), 1740s ($C=O$)
 cm^{-1} ; g.l.c. (polypropylene sebacate) at 174° , H_2 8
 atmospheres gave a single peak (t, 14 min.).

Diethyl 1-methyl-n-propenylpropargylmalonate

Diethyl 1-methyl-n-propylidenemalonate (21.4 g.,
 0.1 mole), sodium ethoxide [from sodium (2.3 g., 0.1 g.
 atom) in absolute ethanol (200 ml.)] and propargyl bromide
 (12.0 g., 0.1 mole) similarly gave diethyl 1-methyl-n-
 propenylpropargylmalonate b.p. $122-126^\circ/8$ mm. (12.6 g.,
 50%) (Found: C, 65.9; H, 8.1; $C_{14}H_{20}O_4$ requires C, 66.6;
 H, 8.2%), ν_{\max} (I.R. 24) 3300s ($C\equiv CH$), 2120w ($C\equiv CH$),
 1740s ($C=O$), 1650w ($C=C$) cm^{-1} ; g.l.c. (silicone oil)
 at 150° , H_2 2 l./hr. gave a single peak (t, 27 min.).

Hex-1-en-5-yne

Allyl magnesium bromide was prepared from magnesium
 turnings (2.4 g., 0.1 g. atom) in dry ether (50 ml.), one
 crystal of iodine catalyst and allyl bromide (12.0 g.,
 0.1 mole). The solution was cooled in ice and propargyl
 bromide (9.6 g., 0.08 mole) in dry ether (25 ml.) was
 added dropwise over 30 min. the mixture stirred for 1 hr.

at 0°, then left overnight at room temperature, decomposed with saturated aqueous ammonium chloride solution, ether layer separated, dried (MgSO₄) and distilled to give as the main fraction hex-1-en-5-yne, b.p. 74-76°/740 mm. (4.0 g., 50%)⁹⁰, D_{\max} (I.R. 64) 3300s(C≡CH), 2120m (C≡CH), 1650s (>C=C<), 1015s, 920s (>C=CH₂) cm.⁻¹; g.l.c. (silicone oil) at 22°, N₂ 2 l./hr. gave a major peak (t, 6 min., 90%) and a minor contaminant (t, 2 min., 10%) identified as ether.

Diethyl 2,2-dimethyl-3,4-pentadienyldenemalonate

Diethyl isobutenylpropargylmalonate (5.1 g., 0.02 mole) was placed in a 25 ml. round-bottomed flask equipped with a two-way adapter carrying a long thin dual-purpose pipette (serving both as a pipette for removing samples after the completion of the pyrolysis and for N₂ inlet during the pyrolysis) and an air condenser with a calcium chloride guard-tube. Dry, oxygen-free N₂ was flushed through the flask to render the system free from oxygen and then the N₂ flow was controlled at a slow, steady rate. The flask was placed in a Wood's metal bath and the bath heated to 270-280°, and maintained at this temperature range so that the malonate refluxed gently. After 15 min. the heating was discontinued and the ester allowed to come down to room temperature (5 min.), one drop of the liquid removed by means of the pipette and its i.r. spectrum determined to check for the near-complete disappearance of the terminal acetylene band ($\bar{D}_{\max} 3300 \text{ cm.}^{-1}$) and the near-maximum absorption of the allene band ($\bar{D}_{\max} 1950 \text{ cm.}^{-1}$) (See Discussion, p.73). The liquid was then distilled using a 6" Fenski-type column, giving some starting material and by-product (identified on g.l.c. as diethyl isobutenylpropargylmalonate and diethyl

isobutylidenemalonate respectively) b.p. 84-105°/0.8 (1.0 g.,) and diethyl 2,2-dimethyl-3,4-pentadienylidene-malonate (1.8 g., 35%), b.p. 128-130°/0.8 mm. (Found: C, 65.8; H, 8.0; C₁₄H₂₀O₄ requires C, 66.6; H, 8.0%), ν_{\max} (I.R.27) 1952m (>C=C<), 1730s (>C=O), 1650m (>C=C<) and 860b (>C=C=CH₂) cm.⁻¹; λ_{\max} 204 m μ (ξ , 12,513); g.l.c. (silicone oil) at 176° N₂ 3.0 l./hr. gave a single peak (t, 52 min.).

Diethyl 1-methyl-3,4-pentadienylidenemalonate

Diethyl isopropenylpropargylmalonate (6.0 g., 0.025 mole) similarly at 270-280° for 15 min. gave some starting propargylmalonate and isopropylidene malonate fission product (1.5 gr) b.p. 100-120°/2 mm. and diethyl 1-methyl-3,4-pentadienylidenemalonate (2.3 g., 39%) b.p. 120-122°/2 mm. (Found: C, 64.9; H, 7.9; C₁₃H₁₈O₄ requires C, 65.3; H, 7.7%), ν_{\max} (I.R.23) 1960m (>C=C<), 1730s (>C=O), 1650m (>C=C<) and 860b (>C=C=CH₂) cm.⁻¹, λ_{\max} 210 m μ (ξ , 10,101); g.l.c. (silicone oil) at 176°, N₂ 3 l./hr. gave a single peak (t, 48 min.).

Diethyl 1,2-dimethyl-3,4-pentadienylidenemalonate

Diethyl 1-methyl n-propenylpropargylmalonate (4.0 g., 0.016 mole) similarly at 270-280° for 10 min. gave some

starting propargylmalonate and alkylidenemalonate fission product (1.2 g.) b.p. 96-112°/0.5 mm. and diethyl 1,2-dimethyl-3,4-pentadienylidenemalonate (1.3 g., 33%) b.p. 118-120°/0.5 mm. (Found: C, 65.6; H, 7.8; C₁₄H₂₀O₄ requires C, 66.6; H, 8.0%); \bar{D}_{\max} (I.R.25) 1960w (C=C=C), 1730s (>C=O) and 860b (C=C=CH₂) cm.⁻¹; λ_{\max} 208 m μ (ϵ , 8,988); g.l.c. (silicone oil) at 174°, H₂ 9 atmospheres gave a single peak (t, 45 min.).

Diethyl 2-ethyl 4-pentenylidenemalonate⁴⁴

Diethyl n-butenylallylmalonate (6.1 g.), 0.02 mole) similarly at 220°/50 mm. for 6 hr. gave some recovered starting material (1.0 g.) and diethyl 2-ethyl 4-pentenylidenemalonate (3.6 g., 61%), b.p. 98-100°/3 mm., \bar{D}_{\max} 1660m (>C=CH₂), 1640m (α,β -conjugated >C=C), 920m (>C=CH₂) cm.⁻¹; g.l.c. (polypropylenesebacate) at 174°, H₂ 9 atmospheres gave a major component (95%, t, 11 min.) and a minor component (5%, t, 8 min., identified as the starting allylmalonate).

Hydrogenation of a sample (0.6 g., 0.0025 mole) in ethanol using Adam's PtO₂, H₂O (0.06 g.) gave diethyl 2-ethyl-pentylmalonate (0.5 g.) (absorption of H₂ 112 ml., theoretical 114 ml.), b.p. 160-162°/30 mm.⁴⁴. The

saturated product (0.25 g.) on condensation with urea in the presence of alcoholic sodium ethoxide¹⁶³ gave 5-(2-ethylpentyl)-barbituric acid (0.1 g.) crystallized from ethanol, m.p. 176° (lit.⁴⁴ 176.5-177°).

Diethyl 2-ethyl-3,4-pentadienylidenemalonate

Diethyl n-butenylpropargylmalonate (5.1 g., 0.02 mole) similarly at 270-280° for 15 min. gave some starting propargylmalonate and n-butyldenemalonate fission product (2.2 g.) and diethyl 2-ethyl 3,4-pentadienylidenemalonate (1.5 g., 29%), b.p. 124-126°/5 min. (Found: C, 66.2; H, 7.9; C₁₄H₂₀O₄ requires H, 66.6; H, 8.0%); ν_{\max} (I.R.19) 1950w (C=C=C), 1730s (>C=O) and 860m (C=C=CH₂) cm.⁻¹; λ_{\max} 206 m μ (ϵ , 10,790); g.l.c. (polypropylenesebacate) at 174°, H₂ 9 atmospheres gave a single peak (t, 21 min.).

Hydrogenation of a sample (0.6 g., 0.0025 mole) in ethanol using Adam's PtO₂, H₂O catalyst (0.06 g.) gave diethyl 2-ethyl-pentylpentylmalonate (0.5 g.) (absorption of H₂ 158 ml., theoretical 171 ml.), b.p. 160-162°/30 mm.⁴⁴ The saturated product (0.25 g.) upon condensation with urea in the usual manner gave 5-(2-ethylpentyl)-barbituric acid (0.1 g.), crystallized from ethanol, mp. 176°.

Isobutyraldehyde dipropargyl acetal^{185,129}

Anhydrous calcium chloride (10 g.) was added to re-distilled propargyl alcohol (56 g., 1.0 mole), shaken for 5 minutes, cooled in ice and isobutyraldehyde (36.0 g., 0.5 mole) added slowly with stirring. After shaking for 3 days on a continuous mechanical shaker, the mixture was filtered and the filtrate distilled giving isobutyraldehyde dipropargyl acetal (60.0 g., 72%) b.p. 62-64°/1.5 mm.

\mathcal{D}_{\max} 3300vs (C≡CH), 2120m (C≡CH), 1050vs (C=O-) and a doublet at 1360m and 1380m (>CMe₂) cm.⁻¹; g.l.c. (dinonylphthalate) at 120°, N₂ 1.7 l./hr. gave a single peak (t, 32 min.).

1-Chloro-isobutyl propargyl ether^{85,129}

Isobutyraldehyde dipropargyl acetal (46.0 g., 0.27 mole) was added dropwise with stirring to boron trichloride (22.0 g., 0.19 mole) cooled in an ice-salt bath. After leaving at -10° for 3 hr. and at room temperature for 3 days, the volatile product was collected under vacuo in a cold trap in alcohol Dewar at -60° and redistilled to give 1-chloro-isobutyl propargyl ether (29.0 g., 70%), b.p. 52-54°/10 mm., \mathcal{D}_{\max} 3290s (C≡CH), 2120m (C≡CH), 1080, 1120vs (C=O-) and 700s (C-Cl) cm.⁻¹.

2,2-dimethylpenta-3,4-dienal^{85,129}

1-Chloro-isobutylpropargyl ether (19 g., 0.13 mole) was heated under reflux (bath temperature 150°) in the presence of hydroquinone (0.002 g.). After 6 hr., distillation gave 2,2-dimethylpenta-3,4-dienal (8.0 g., 56%), b.p. 126-127°/760 mm., $D_{\max}^{2700m}(\text{CHO})$ 1950vs ($>\text{C}=\text{C}=\text{C}<$), 850s ($>\text{C}=\text{C}=\text{CH}_2$) and 1740vs ($>\text{C}=\text{O}$) cm.^{-1} ; g.l.c. (dinonylphthalate) at 90°, N_2 1.7 l./hr.) gave a single peak (t, 12 min.), dinitrophenylhydrozone derivative (orange needles) m.p. 122°.

Diethyl 2,2-dimethyl-3,4-pentadienyldenemalonate

2,3-Dimethyl-penta-3,4-dienal (5.5 g., 0.05 mole), diethylmalonate (8.0 g., 0.05 mole), anhydrous ammonium acetate (1.0 g.) and dry benzene (25 ml.) were refluxed using a Dean and Stark apparatus for 12 hr. Water (50 ml.) and ether (50 ml.) were added, the organic layers separated, washed with water (3 x 25 ml.), dried (MgSO_4), volatile materials removed on the rotary evaporator and the residual oil distilled to give two fractions:- (i) 86-88°/15 mm. (4.0 g.,) identified by i.r. and g.l.c. as diethyl malonate, and (ii) 128-136°/1 mm. (2.5 g.). Redistillation of fraction (ii) gave pure diethyl 2,2-dimethyl-3,4-penta-

dienylidenemalonate (2.0 g., 16%) with identical i.r.
and g.l.c. as the sample obtained by Cope rearrangement of
diethyl isobutenylpropargylmalonate

Cyclopropanes from α, β -Unsaturated Esters by the
Dimethylsulphoxonium Methylide Reaction

Trimethylsulphoxonium iodide¹⁵⁹

In a 1 l. round-bottomed flask equipped with a ground-glass sealed mechanical stirrer, N₂ inflow tube and a cold-water condenser with a calcium chloride guard tube was placed a solution of methyl iodide (250 ml.) in dry dimethyl sulphoxide (150 g., 1.4 mole) and the solution under N₂ was refluxed over an electric mantle for 3 days. The mixture was cooled, filtered, the solid washed with chloroform (3 x 100 ml.) and acetone (2 x 100 ml.), powdered and dried in the oven at 100° giving trimethylsulphoxonium iodide as a white crystalline solid (247 g. 80%), recrystallized from water, m.p. 200°.

Trimethylsulphoxonium chloride⁵³

Trimethylsulphoxonium iodide (30 g., 0.136 mole) was dissolved in water (300 ml.) at 50° and chlorine gas bubbled through the solution until no more iodine precipitated. The mixture was cooled, the aqueous layer decanted off from iodine, washed with ether to remove iodine (3 x 50 ml.), water removed on the rotary evaporator and dried in the vacuum desiccator to yield trimethylsulphoxonium chloride as a white crystalline solid (13.5 g., 77%), m.p. 220°.

Ethyl trans-2-methylenecyclopropane-1-carboxylate

Method (a): To a suspension of sodium hydride (1.2 g., 0.05 mole) and dry dimethylsulphoxide (100 ml.) was added in one portion solid trimethylsulphoxonium iodide (11.05 g., 0.052 mole). An exothermic reaction took place with evolution of hydrogen. The mixture was stirred for 45 min. by which time the evolution of hydrogen had ceased and the mixture had attained room temperature. Trans-Ethyl crotonate (5.7 g., 0.05 mole) in dimethyl sulphoxide (15 ml.) was added to the methylide in one portion. An exothermic reaction took place and the mixture turned slightly yellow. Stirring was continued for another 2 hr. without any external heating or cooling. The mixture was poured into hydrochloric acid/ice water (100 ml., 3%), extracted with ether (3 x 50 ml.), the ether extract washed with water (2 x 100 ml.), dried ($MgSO_4$) and distilled giving ethyl trans-2-methyl-cyclopropanecarboxylate (3.8 g., 60%) b.p. $76^\circ/70\text{ mm}^{150}$. (Found: C, 65.3; H, 9.5% calculated for $C_7H_{12}O_2$: C, 65.6; H, 9.4%), \bar{D}_{\max} (I.R.30) 1740s ($>C=O$), 1020m (cyclopropane) cm^{-1} , λ_{\max} (U.V.4) 206 $m\mu$ ($\epsilon, 160$); g.l.c. (silicone oil) at 80° showed a single peak, t 12 min.

Method (b): To a suspension of sodium hydride (1.2 g., 0.05 mole) in dimethylformamide (100 ml.) was

added in one portion solid trimethylsulphoxonium iodide (11.05 g., 0.052 mole). An exothermic reaction took place with copious evolution of hydrogen. After all the hydrogen had been evolved (5 min.) the mixture was stirred another 15 min. and ethyl crotonate (5.7 g., 0.05 mole) in dimethyl formamide (15 ml.) was added to the methyllide in one portion. An exothermic reaction took place and the mixture turned slightly yellow. Stirring was continued for another 1 hr. The mixture was poured into hydrochloric acid/ice-water (100 ml. 3%), extracted with ether (3 x 50 ml.), the ether extract washed with water (2 x 25 ml.), the combined ether layer dried (MgSO_4) and distilled giving ethyl trans-2-methylcyclopropane-1-carboxylate (4.0 g., 63%) b.p. $74-76^\circ/70$ mm., i.r., u.v., and g.l.c. identical with those from the product from method (a). N.m.r. (N.m.r.12) showed a quartet for the ester methylene protons at γ 5.96 ($J=7.2$ c./sec.) and a triplet for the ester methyl protons at γ 8.78 ($J=7.2$ c./sec.).

Ethyl cyclopropanecarboxylate

Method (a): Sodium hydride (2.4 g., 0.1 mole), dimethyl sulphoxide (150 ml.), trimethylsulphoxonium iodide (22.1 g., 0.1 mole) and ethyl acrylate (10.1 g., 0.1 mole) in dimethyl sulphoxide (25 ml.) gave ethyl-

cyclopropanecarboxylate, b.p. 134-135° (lit.¹⁵¹ 135°), (7.4 g., 65%), \bar{D}_{\max} 1750s ($>C=O$), 1050m (cyclopropane) cm.^{-1} , λ_{\max} 207 μ (ξ , 106); g.l.c. (silicone oil) at 70° gave a single peak (t, 7 min.) identical with an authentic sample prepared by esterification of cyclopropanecarboxylic acid¹⁵².

Methyl-1-methylcyclopropane-1-carboxylate

Method (a): gave no ether soluble product.

Method (b): Sodium hydride (2.4 g., 0.1 mole), dimethylformamide (150 ml.), trimethylsulphoxonium iodide (22.1 g., 0.1 mole) and methyl methacrylate (10.0 g., 0.1 mole) in dimethylformamide (25 ml.) gave methyl 1-methylcyclopropane-1-carboxylate, b.p. 72°/120 mm.¹⁵³ (2.6 g., 20%), \bar{D}_{\max} (I.R.29) 1740s ($>C=O$). 1028m (cyclopropane) cm.^{-1} ; λ_{\max} 206 μ (ξ , 194) [Lit.¹⁵⁰ for ethyl ester, λ_{\max} 215.5 μ (ξ , 604)]; g.l.c. (silicone oil) at 80° gave a single peak (t, 7 min.) (Found: C, 63.2; H, 8.7; $C_6H_{10}O_2$ requires C, 63.1; H, 8.7).

Ethyl trans-hex-2-enoate

Trans-hex-2-enoic acid :-

n-Butyraldehyde (36.0 g., 0.5 mole) was poured onto the solution of malonic acid (41.6 g., 0.4 mole) in dry pyridine (50 ml.), and the mixture refluxed until the carbon dioxide ceased to evolve (3 hr.) The mixture

was added to ice-cold 50% hydrochloric acid (50 ml.) and refrigerated overnight. The crystalline solid was filtered, recrystallized from chloroform and dried in a vacuum desiccator to yield trans-hex-2-enoic acid (17.1 g., 30%), m.p. 72°.

Ethyl trans-hex-2-enoate

Trans-hex-2-enoic acid (14.3 g., 0.25 mole) was dissolved in absolute ethanol (100 ml.) and concentrated sulphuric acid (10 ml.) added with stirring. The mixture was stirred for 24 hf., water (200 ml.) and ether (100 ml.) added, the organic layer removed, washed with saturated aqueous sodium bicarbonate solution (3 x 50 ml.), water (2 x 50 ml.), dried ($MgSO_4$) and distilled to give ethyl trans-hex-2-enoate 90-92°/2 mm. (lit.¹⁵⁴ 83-85°/0.25 mm.).

Ethyl trans-3-propylcyclopropane-1-carboxylate

Method (b): Sodium hydride (1.2 g., 0.05 mole), dimethylformamide (100 ml.), trimethylsulphoxonium iodide (11.05 g., 0.052 mole), ethyl hex-2-enoate (7.1 g., 0.05 mole) in dimethylformamide (15 ml.) gave ethyl trans-3-propylcyclopropane-1-carboxylate, b.p. 80-82°/5 mm. (6.5 g., 79%), D_{max}^{1750s} ($\overset{\curvearrowright}{C}=O$), 1038m (cyclopropane);

$\lambda_{\max} 207 \text{ m}\mu (\epsilon, 187)$; g.l.c. (silicone oil) at 125° gave a single peak (t, 9 min.), (Found: C, 69.2; H, 10.1; $\text{C}_9\text{H}_{16}\text{O}_2$ requires C, 69.2; H, 10.1%).

Ethyl trans-2-phenylcyclopropane-1-carboxylate

Method (a): Sodium hydride (1.2 g., 0.05 mole), dimethyl sulphoxide (100 ml.), trimethylsulphoxonium iodide (11.05 g., 0.052 mole) and trans-ethyl cinnamate (8.8 g., 0.05 mole) in dimethyl sulphoxide (15 ml.) gave recovered trans-ethyl cinnamate, b.p. $98-100^\circ/1 \text{ mm.}$ (5.0 g.,) and ethyl trans-2-phenylcyclopropane-1-carboxylate $108-110^\circ/1 \text{ mm.}$ (3.0 g., 31%). Refractionation gave b.p. $100^\circ/1 \text{ mm.}$ (2.7 g., 30%) (lit.¹⁵⁵ $103-105^\circ/0.5-0.7 \text{ mm.}$); $\bar{\nu}_{\max}$ (I.R.33) $1740\text{s} (>\text{C}=\text{O}), 1610\text{m}$ (aromatic), 1040m (cyclopropane) cm.^{-1} ; $\lambda_{\max} 205 \text{ m}\mu$ ($\epsilon, 11,750$), $222\text{m}\mu$ ($\epsilon, 8,700$); g.l.c. (silicone oil) at 178° , N_2 1.6 l/hr.^{-1} gave a single peak (t, 19 min.) Hydrolysis of the ester gave trans-2-phenylcyclopropane-1-carboxylic acid, m.p. 94° (lit.¹⁵⁵ 93°).

Method (b); Similarly gave ethyl trans-2-phenylcyclopropane-1-carboxylate in 42% yield.

Trans-penta-2,4-dienoic acid

To malonic acid (100 g., 0.96 mole) dissolved in pyridine (100 ml.) was added acrolein (56.0 g., 1.0 mole)

and the mixture refluxed until no more carbon dioxide was evolved (3 hr.). The mixture was cooled in ice, cold 40% sulphuric acid (100 ml.) added to it and it was refrigerated overnight. The solid was filtered, recrystallized from chloroform and dried in a vacuum desiccator to yield trans-penta-2,4-dienoic acid (25.0 g., 26%), m.p. 71°.

Ethyl trans-penta-2,4-dienoate

Trans-penta-2,4-dienoic acid (20.0 g., 0.2 mole) was mixed with absolute ethanol (75 ml.) and dry benzene (150 ml.) and concentrated sulphuric acid (20 ml.) was added to it. The mixture was refluxed for 6 hr., water (200 ml.) added to it, extracted with ether (2 x 100 ml.), washed with water (100 ml.), saturated aqueous sodium bicarbonate solution (2 x 100 ml.), water (200 ml.), dried (MgSO₄), solvents removed on a rotary evaporator and distilled to give ethyl trans-penta-2,4-dienoate (20.0 g., 80%) b.p. 58-60°/15 mm., $\bar{\nu}_{\max}$ (I.R.36) 1730s (>C=O), 1650m (>C=C<), 1610m (>C=C<) cm.⁻¹, λ_{\max} (U.V.6) 247 m μ (ξ , 23,200), g.l.c. (silicone oil) at 80°, N₂ 2 l/hr. gave a single peak at t, 18 min.

Ethyl 1,2-methylenepent-3-enoate

Method (a): Sodium hydride trimethylsulphoxonium iodide (3.6g.,

0.15 mole), dimethyl sulphoxide (150 ml.), trimethylsulphoxonium iodide (33.15 g., 0.156 mole) and ethyl trans-2,4-pentadienoate (12.6 g., 0.1 mole) in dimethyl sulphoxide (25 ml.) gave ethyl 1,2-methylenepent-3-enoate, b.p. $58^{\circ}/1$ mm. (8.2 g., 62%), $\lambda_{\max}^{\text{IR}}$ 1740s ($\text{C}=\text{O}$), 1650w ($\text{C}=\text{C}$), 1040m (cyclopropane) cm.^{-1} ; $\lambda_{\max}^{\text{UV}}$ (U.V.6) 205 m μ (ϵ , 2,890); g.l.c. (silicone oil) at 120° gave a major component (95%; t, 20 min.) and a minor component (5%; t, 22 min.). The latter was probably the bis-adduct which could not be removed completely by fractionation. (Found: C, 69.1; H, 9.2; calculated for $\text{C}_8\text{H}_{12}\text{O}_2$ C, 68.5; H, 8.6%)

Ethyl 1,2-methylene-hex-3-enoate

Method (a):

(i) Sodium hydride (1.2 g., 0.05 mole), dimethyl sulphoxide (100 ml.) trimethylsulphoxonium iodide (11.05 g., 0.052 mole) and ethyl sorbate (7.0 g., 0.05 mole) in dimethyl sulphoxide (15 ml.) and stirring at room temperature for 2 hr. gave the products b.p. $92-96^{\circ}/12$ mm. (4.6 g.,) which consisted of four components on g.l.c. (silicone oil) at 125° : t, 9 min. (70%, unreacted ethyl sorbate), t, 10 min. (5% ethyl 4,5-methylene-hex-2-enoate) t, 14 min. (20% ethyl 2,3-methylene-hex-4-enoate) and t, 18 min. (5% ethyl 2,3,4,5-dimethylene hexanoate).

(ii) As in (i) except that the solution of the methylide

in dimethyl sulphoxide was cooled at 0° then ethyl sorbate in dimethyl sulphoxide added in one portion, and the mixture stirred for 3 hr. at room temperature, 1 hr. at 60° and 1 hr. at room temperature, gave after working up, the products b.p. $96-98^{\circ}/12$ mm. (5.0 g.), which consisted of two components on g.l.c. at 125° ; t, 9 min. (33% ethyl sorbate) and t, 14 min. (66%, ethyl 2,3-methylene hex-4-enoate).

(iii) Sodium hydride (2.4 g., 0.1 mole), dimethyl sulphoxide (150 ml.), trimethylsulphoxonium iodide (22.1 g., 0.104 mole) and ethyl sorbate (7.0 g., 0.05 mole) in dimethyl sulphoxide (25 ml.) gave under the same conditions as in (ii), the product b.p. $104-108^{\circ}/15$ mm. (4.7 g.), which consisted of four components on g.l.c. at 125° : t, 9 min. (25%, ethyl sorbate), t, 10 min. (15%, ethyl trans-4,5-methylenehex-2-enoate), t, 14 min. (55%, ethyl 2,3-methylenehex-4-enoate), and t, 18 min. (5%, ethyl 2,3,4,5-dimethylenehexanoate).

Two refractionations gave ethyl 2,4-methylene hex-4-enoate, b.p. $106^{\circ}/14$ mm (0.2 g.), ν_{\max} (I.R.66) 1750s ($>C=O$), 1650s ($>C=C<$) cm.^{-1} , λ_{\max} (U.V.7) 235 $\text{m}\mu$ (ϵ , 17,160). (Found: C, 70.0; H, 8.9; $\text{C}_9\text{H}_{14}\text{O}_2$ requires C, 70.1; H, 9.1%) and ethyl 4,5-methylene-hex-2-enoate, b.p. $106-108^{\circ}/12$ mm.

(2.7 g.) (Found: C, 70.3; H, 9.2; $C_9H_{14}O_2$ requires C, 70.4; H, 9.1%. $C_{10}H_{16}O_2$ requires C, 71.4; H, 9.6%),
 ν_{\max} (I.R.39) 1750s ($>C=O$), 1650w ($>C=C<$) cm^{-1} ,
 λ_{\max} (U.V.7) 207 $m\mu$ (ϵ , 3,755); g.l.c. showed that the product was contaminated with 10% of ethyl 2,3,4,5-dimethylenehexanoate.

(iv) Sodium hydride (2.4 g., 0.1 mole), dimethyl sulphoxide (150 ml.), trimethylsulphoxonium iodide (22.1 g., 0.104 mole) and ethyl sorbate (3.5 g., 0.025 mole) in dimethyl sulphoxide (25 ml.) gave under the same conditions as in (ii) b.p. 106-108°/15 mm. (2.7 g. 70%), identified on g.l.c. at 125° as ethyl 2,3-methylene-hex-4-enoate (t, 14 min. 50% on g.l.c.) and ethyl 2,3,4,5-dimethylenehexanoate (t, 18 min., 50% on g.l.c.).

Hydrogenation of a sample (0.35 g., 0.005 mole) using Adam's PtO_2 , H_2O catalyst (0.5 g.) in methanol (50 ml.) absorbed 79 cc. of H_2 (theoretical absorption, 72.5 c.c.) in 15 min. G.l.c. at 125° gave two components: t, 16 min. (50% ethyl 3-n-propylcyclopropane) and t, 18 min. (50%, common to both the hydrogenated and the unhydrogenated samples, therefore the bis-adduct, ethyl 2,3,4,5-dimethylenehexanoate).

Ozonolysis of the sample (0.5 g.) followed by hydrogenolysis gave acetaldehyde, dimedone derivative (0.3 g.), m.p. and mixed m.p. 140-141°.

Diethyl trans-cyclopropane-1,2,-dicarboxylate

Method (b): Sodium hydride (1.2 g., 0.05 mole), dimethylformamide (100 ml.), trimethylsulphoxonium iodide (11.05 g., 0.05 mole) and ethyl fumarate (8.6 g., 0.05 mole) in dimethylformamide (25 ml.) gave some recovered ethyl fumarate and diethyl trans-cyclopropane-1,2-dicarboxylate, b.p. 108°/12 mm. (3.9 g., 42%) (lit.¹⁵⁶ 106.5-107°/11 mm.) identified as diethyl cyclopropane-1,2-dicarboxylate, ν_{\max} (I.R.42) 1740s (>C=O), 1035 cm.⁻¹; g.l.c. (silicone oil) at 174°, N₂ 2 l./hr. gave a single peak t, 7 min. Hydrolysis of the ester yielded trans-cyclopropane-1,2-dicarboxylic acid, m.p. 174-175° (lit.¹⁵⁷ 175°).

Diethyl 2-methylcyclopropane-1,1-dicarboxylate

Method (b): Sodium hydride (1.2 g., 0.05 mole), dimethylformamide (100 ml.), trimethylsulphoxonium iodide (11.05 g., 0.052 mole) and diethyl ethylidenemalonate (9.3 g., 0.05 mole) in dimethylformamide (15 ml.) gave diethyl 2-methylcyclopropane-1,1-dicarboxylate, b.p. 66-68°/0.05 mm. (8.0 g., 80%), ν_{\max} (I.R.43) 1740s (>C=O), 1030 cm (cyclo-

propane) cm.^{-1} λ_{max} $\text{m}\mu$ (ϵ , 300); g.l.c. (silicone oil) at 160° , H_2 9 atmospheres gave a single peak t, 10 min. (Found: C, 60.2; H, 8.1; $\text{C}_{10}\text{H}_{16}\text{O}_4$ requires C, 60.0; H, 8.0%). N.m.r. (N.m.r.13) showed two quartets for the pair of nonequivalent ester methylene protons at γ 5.82 and 5.86 ($J=7.2$ c./sec. for each quartet).

Diethyl 2,2-dimethylcyclopropane-1,1-dicarboxylate

Method (b): Sodium hydride (1.2 g., 0.05 mole), dimethylformamide (100 ml.), trimethylsulphoxonium iodide (11.05 g., 0.052 mole) and diethyl isopropylidene malonate (10.0 g., 0.05 mole) in dimethylformamide (25 ml.) gave diethyl 2,2-dimethylcyclopropane-1,1-dicarboxylate b.p. $85-86^\circ/0.5$ mm. (9.7 g., 91%), ν_{max} (I.R.44) 1740s ($>\text{C}=\text{O}$), 1030 (cyclopropane) cm.^{-1} , λ_{max} 204 $\text{m}\mu$ (ϵ , 541), λ_{sh} 220 $\text{m}\mu$ (ϵ , 325); g.l.c. (silicone oil) at 170° , H_2 170^o 9 atmospheres gave a single peak t, 10 min. (Found: C, 61.5; H, 8.3; $\text{C}_{11}\text{H}_{18}\text{O}_4$ requires C, 61.6; H, 8.5%). N.m.r. (N.m.r. 17) showed a quartet for the pair of equivalent ester methylene protons at γ 5.90 ($J=7.2$ c./sec.) and a triplet for the pair of equivalent ester methyl protons at γ 8.71 ($J=7.2$ c./sec.).

Diethyl 2-ethylcyclopropane-1,1-dicarboxylate

Method B: Sodium hydride (1.2 g., 0.05 mole), dimethylformamide (100 ml.), trimethylsulphoxonium iodide (11.05 g., 0.052 mole) and n-propylidenemalonate (10.0 g., 0.05 mole) in dimethylformamide (25 ml.) gave the product ~~(XXV)~~ b.p. 102-104°/3 mm. (9.1 g., 85%), \bar{D}_{\max} 1740s ($>C=O$), 1022m (cyclopropane) cm.^{-1} , λ_{\max} 208m μ (ϵ , 342); g.l.c. at 150° on polypropylene sebacate H_2 8 atmospheres gave a single peak (t, 16 min.). (Found: C, 61.7; H, 8.5; $C_{11}H_{18}O_4$ requires C, 61.7; H, 8.5%). N.m.r. (N.m.r. 15) showed ~~a~~ two quartets for the pair of nonequivalent ester methylene protons at τ 5.80 and 5.84 (J=7.2 c./sec. for each quartet).

Diethyl 2-isopropylcyclopropane-1,1-dicarboxylate

Method B: Sodium hydride (1.2 g., 0.05 mole), dimethylformamide (100 ml.), trimethylsulphoxonium iodide (11.05 g., 0.052 mole) and iso-butylidene malonate (11.4 g., 0.05 mole) in dimethylformamide (25 ml.) gave the product ~~(XXVI)~~ b.p. 110°/2 mm. (10.1 g., 89%), \bar{D}_{\max} 1740s ($>C=O$), 1022m (cyclopropane) cm.^{-1} , \bar{D}_{\max} 209 m μ (ϵ , 402); g.l.c. at 150° on polypropylene sebacate, H_2 8 atmospheres gave a single peak (t, 12.5 min.), (Found: C, 63.1; H, 8.8; $C_{12}H_{20}O_4$ requires C, 63.1; H, 8.8%). N.m.r. (N.m.r. 20) showed two quartets for the pair of two nonequivalent ester

methylene protons at γ 5.80 and 5.84 ($J=7.2$ c./sec. for each quartet).

Diethyl 2-phenylcyclopropane-1,1-dicarboxylate

Method B: Sodium hydride (2.48g., 0.10 mole), dimethylformamide (200 ml.), trimethylsulphoxonium iodide (22.1 g., 0.104 mole) and benzylidenemalonate (24.8 g., 0.10 mole) in dimethylformamide (50 ml.) gave the product ~~2,2-dimethyl-3-phenylcyclopropyl methyl ketone~~ b.p. $140^{\circ}/0.1$ mm. (20.0 g., 76%), ν_{\max} 1740s ($>C=O$), 1610m (aromatic), 1025m (cyclopropane) cm.^{-1} , λ_{\max} 204 μ (ϵ 9,940) 210 μ (ϵ 9,890), 218 μ (ϵ 10,480). (Found: C, 67.6; H, 7.0; $C_{15}H_{18}O_4$ requires C, 68.6; H, 6.9%). N.m.r. (N.m.r.22) showed two quartets for the pair of nonequivalent ester methylene protons at γ 5.72 and 6.12 ($J=7.2$ c./sec. for each quartet), two triplets for the pair of nonequivalent ester methyl protons at γ 8.71 and 9.14 ($J=7.2$ c./sec. for each triplet) and a doublet for the phenyl protons ($\frac{\text{Ph}}{\text{H}}$ ~~at γ 2.70~~) at γ 2.70.

2,2-Dimethyl-cyclopropyl methyl ketone

Sodium hydride (2.4 g., 0.1 mole), trimethylsulphoxonium iodide (22.1 g., 0.1 mole) and mesityl oxide (9.85 g., 0.1 mole) in dimethylformamide (25 ml.) gave 2,2-dimethyl cyclopropylmethyl ketone, b.p. $40-42^{\circ}/30$ mm. (lit.¹⁵⁰ b.p. $48-50^{\circ}/40$ mm.) (8.5 g., 76%) ν_{\max} (I.R.35) 1710s ($>C=O$), 1012w (cyclopropane) cm.^{-1} , λ_{\max} (U.V.9) 210 μ (ϵ 2,485);

g.l.c. (silicone oil) at 80° gave a single peak t, 8 min. (Found: C, 74.9; H, 10.6; $C_7H_{11}O$ requires C, 74.9; H, 10.8%); 2,4-dinitrophenylhydrazone m.p. 176° (lit¹⁵⁸ 159°).

Ethyl but-2,3-dienoate

But-1-yn-4-ol

To liquid ammonia (3.5 l.) in a well-lagged 5 l. flask was added a crystal of ferric nitrate followed by sodium (23.0 g., 1.0 mole). Acetylene was passed after half the sodium had been added and the passage continued until the blue coloration of the ammonia solution had changed to whitish-grey (4 hr.). Ethylene oxide (200 ml., 4.5 moles) precooled to -40° was added to the ammonia solution in one portion, the passage of acetylene continued for 4 hrs. and the mixture left to stand overnight, then decomposed with solid ammonium chloride (250 g.) and excess ammonia allowed to evaporate, ether (200 ml.) added, the residue filtered, washed with ether (3 x 200 ml.), filtered, the combined ether layer dried ($MgSO_4$), and

distilled to yield but-1-yn-4-ol (140 g., 50%), b.p. $126-130^{\circ}$, $D_{max}^{25} 3400s$ (-OH), $3300s$ ($C\equiv CH$) and $2120w$ ($C\equiv CH$) cm^{-1} .

But-3-ynoic acid¹⁶⁰

To a solution of but-1-yn-4-ol (80 g., 0.88 mole) in

water (120 ml.) and acetone (300 ml.) cooled to 0° was added chromic acid [prepared from chromium trioxide (180 g.) dissolved in cold water (250 ml.) and concentrated sulphuric acid (160 ml.) added, and the solution diluted to 800 ml.] over 30 min. The temperature of the mixture was kept at $10-20^{\circ}$ throughout the addition of chromic acid by means of cooling in ice-salt mixture. After the addition, the dark green mixture was stirred for 30 min. at room temperature, water (200 ml.) and ether (200 ml.) added, ether layer removed, aqueous layer extracted with ether (2 x 100 ml.), the ether layer extracted with saturated aqueous sodium bicarbonate solution (3 x 100 ml.), the aqueous layer acidified with 20% hydrochloric acid and the acid extracted with ether (3 x 100 ml.), ether layer dried (MgSO_4) and ether removed on a rotary evaporator and dried in a vacuum desiccator to yield but-3-ynoic acid (14.1 g., 24%), m.p. 65° (recrystallized from light petrol) (lit.¹⁶¹ m.p. 65°).

Ethyl buta-2,3-dienoate¹⁶¹

To a solution of but-3-ynoic acid (12.9 g., 0.15 mole) in absolute ethanol (100 ml.) was added concentrated sulphuric acid (6 ml.) and the solution kept aside for 7 days at room temperature. An excess of a

saturated aqueous potassium carbonate solution was added and the solution filtered. After removal of most of the ethanol by distillation and addition of water (250 ml.), the neutral fraction was isolated with ether and distilled giving ethyl buta-2,3-dienoate (6.9 g., 41%), b.p. $66^{\circ}/70$ mm.¹⁶²

ν_{\max} (I.R.49) 1970s and 1950 ($>C=C=C<$), 1730s ($>C=O$) and 860b ($>C=C=CH_2$) $cm.^{-1}$; λ_{\max} (U.V.10) 208 $m\mu$ (ϵ 8,088); g.l.c. (apiezon L) at 80° , N_2 1.8 l./hr. gave a single peak at t, 12 min. N.m.r. (N.m.r.7) showed a quartet for the ester methylene protons at τ 5.80 ($J=6.6$ c./sec.), a triplet for the ester methyl protons at τ 8.72 ($J=7.2$ c./sec.), and two sets of quartets for the allene proton ($CH_2=C=C\text{---}H$) at τ 4.35 and 4.77.

Reaction of dimethylsulphoxonium methylide and buta 2,3-dienoate

To a suspension of sodium hydride (1.2 g., 0.05 mole) in sodium-dried tetrahydrofuran (150 ml.) was added solid trimethylsulphoxonium chloride (6.45 g., 0.052 mole) in one portion and the mixture refluxed gently for 3 hr. Sodium chloride was quickly filtered, and the filtrate cooled to 0° in ice and ethyl buta-2,3-dienoate (5.6 g., 0.05 mole) in tetrahydrofuran (15 ml.) was added in one portion. The mixture was stirred for 1 hr. and the

solvent removed rapidly in vacuo. The resultant light red oil had no band at 1950 cm.^{-1} and showed λ_{max} (U.V.10) $210 \text{ m}\mu$ ($\epsilon, 2,590$), $339 \text{ m}\mu$ ($\epsilon, 5,480$); the extinction coefficients decreased rapidly owing to decomposition of the unstable product formulated as dimethylsulphoxonium 3-ethoxycarbonyl-3-methylallylide, ν_{max} (I.R. 50) 1725s ($>\text{C}=\text{O}$), 1680s , 1580s ($>\text{C}=\text{C}<$), 1028s ($-\text{SO}-$) cm.^{-1} .

(-) Trans-menthyl cinnamate

To a solution of (-)-menthol $[\alpha]_{\text{D}}^{20} - 85.0$ (c, 10; chloroform), (15.6 g., 0.1 mole) and trans-cinnamic acid (16.3 g., 1.1 mole) in dry benzene (200 ml.) was added concentrated sulphuric acid (10 ml.) and the mixture refluxed using a Dean and Stark apparatus for 3 hr., then cooled, water (200 ml.) and ether (100 ml.) added, the organic layer separated, washed with saturated aqueous sodium bicarbonate solution (3 x 200 ml.), the organic layer dried (Na_2CO_3), ether removed on the rotary evaporator and the residual oil distilled giving (-)-menthyl cinnamate (14.7 g., 75%), b.p. $110-114^\circ/0.005 \text{ mm.}$, $[\alpha]_{\text{D}}^{20} - 25.42^\circ$ (c, 6; ethanol); ν_{max} 1750ms ($>\text{C}=\text{O}$), 1650m ($>\text{C}=\text{C}<$) and 1600w (aromatic) cm.^{-1} .

(-)-Trans-menthyl crotonate

(-)-Menthol $[\alpha]_D^{20}$ -85.0 (c, 10; chloroform)
 (15.6 g., 0.1 mole) trans-crotonic acid (17.2 g., 0.2 mole), dry benzene (200 ml.) and concentrated sulphuric acid (10 ml.) after refluxing for 12 hr. similarly gave (-)-menthyl crotonate (8.0 g., 48%) b.p. 80-82°/1 mm. $[\alpha]_D^{20}$ -18.0° (c, 6; ethanol); $D_{\max}^{1750\text{ms}}$ (>C=O) and 1650m (>C=C<) cm.^{-1} .

(-)-Trans-menthyl 2-phenylcyclopropane-1-carboxylate

(-)-Trans-menthyl cinnamate $[\alpha]_D^{20}$ -25.42° (9.8 g., 0.05 mole) in dimethylformamide (25 ml.) was added to dimethylsulphoxonium methylide [prepared from sodium hydride (1.2 g., 0.05 mole), trimethylsulphoxonium iodide (11.1 g., 0.05 mole) and dimethylformamide (150 ml.)] and the mixture stirred for 1 hr., worked up as usual and distilled to give (-)-trans-menthyl 2-phenylcyclopropane-1-carboxylate (8.3 g., 79%), b.p. 118-120°/0.005 mm., $[\alpha]_D^{20}$ -31.1° (c, 6; ethanol); $D_{\max}^{1750\text{ms}}$ (>C=O), 1450ms, 1024m (cyclopropane) cm.^{-1} .

(-)-(1R,2R)-Trans-2-phenylcyclopropane-1-carboxylic acid

(-)-Trans-menthyl 2-phenylcyclopropane-1-carboxylate (8.0 g., 0.04 mole) was dissolved in alcoholic potash

(10%, 100 ml.), refluxed for 3 hr., the resultant liquid cooled in ice and acidified with hydrochloric acid (50%, 100 ml.), extracted with ether (4 x 50 ml.), the ether layer isolated and extracted with saturated aqueous sodium bicarbonate (3 x 100 ml.), the combined aqueous extract reacidified with hydrochloric acid (20%, 100 ml.) and extracted with ether. The ether layer was dried (MgSO_4) and ether evaporated to yield a white crystalline solid devoid of the characteristic menthol odour. Recrystallization from chloroform gave (-)-trans-2-phenylcyclopropane-1-carboxylic acid as white crystalline solid (3.2 g., 50%), m.p. 95° , $[\alpha]_D^{20} - 18.8^\circ$ (c, 4, ethanol).

Esterification of the acid (3.0 g., 0.02) using absolute ethanol (25 ml.), dry benzene (10 ml.) and concentrated sulphuric acid (2 ml.) gave ethyl (-)-trans-2-phenylcyclopropane-1-carboxylate, b.p. $110^\circ/1$ mm. (2.5 g., 66%), $[\alpha]_D^{20} - 17.3^\circ$ (c, 4.5; ethanol); $\nu_{\text{max}} 1750\text{cm}^{-1}$ ($\text{C}=\text{O}$), 1610w (aromatic), 1040m (cyclopropane) cm^{-1}

(-)-Trans-menthyl 2-methylcyclopropane-1-carboxylate

(-)-Trans-menthyl crotonate $[\alpha]_D^{20} - 18.0^\circ$ (c, 6; ethanol) (7.3 g., 0.03 mole) in dimethylformamide (25 ml.) was added to dimethylsulphoxonium methylide \square prepared from

sodium hydride (0.8 g., 0.33 mole), trimethylsulphoxonium iodide (7.5 g., 0.33 mole) and dimethylformamide (100 ml.) and the mixture stirred for 1 hr., worked up as usual and distilled to give (-)-trans-menthyl 2-methylcyclopropane-1-carboxylate (5.0 g., 60%), b.p. $96^{\circ}/1$ mm., $[\alpha]_D^{20} -16.6^{\circ}$ (C, 7; ethanol), ν_{\max} 1750m ($>C=O$), 1020m (cyclopropane) cm.^{-1}

(-)-(1R,2R)-trans-2-methylcyclopropane-1-carboxylic acid

(-)-Trans-menthyl 2-methylcyclopropane-1-carboxylate (4.5 g., 0.015 mole) was dissolved in alcoholic potash (10%, 50 ml.), refluxed for 3 hr., the resultant liquid cooled in ice and acidified with hydrochloric acid (50%, 50 ml.), extracted with ether (4 x 30 ml.), the ether layer isolated and extracted with saturated aqueous sodium bicarbonate (3 x 50 ml.), the combined aqueous extract reacidified with hydrochloric acid (20%, 50 ml.) and extracted with ether, the ether layer dried (MgSO_4) and ether evaporated to yield a white crystalline solid devoid of the characteristic menthol odour. Recrystallization from chloroform gave (-)-(1R,2R)-trans-2-methylcyclopropane-1-carboxylic acid (0.7 g., 45%), m.p. 72° , $[\alpha]_D^{20} - 3.28^{\circ}$ (C, 11; ethanol).

Esterification of the acid (0.04 g., 0.004 mole) using absolute ethanol (10 ml.) and concentrated sulphuric acid (0.5 ml.) gave the ethyl ester $[\alpha]_D^{20} - 0.91^\circ$ (c, 5; ethanol).

Laballenic AcidTrans-pent-2-en-4-yn-1-ol

A catalytic quantity of ferric nitrate (ca. 0.1 g.) followed by sodium metal (92.0 g., 4.0 g atom) was added with stirring to liquid ammonia (4 l.) contained in a well-lagged 5 l. flask. When one quarter of the sodium had been added, a rapid stream of acetylene gas was passed into the solution below the surface and continued until the blue coloration changed to greyish-white (ca. 4 hrs.) 1-Chloro-2,3-epoxypropane (185 g., 2.0 mole) was added dropwise over 3 hr., the passage of acetylene then being maintained at a reduced rate for further 2 hr. after which the passage of acetylene was stopped. The mixture was allowed to stand overnight, then ammonium chloride (212 g., 4.0 mole) was slowly added with stirring, excess ammonia was allowed to evaporate, the reddish residue extracted with ether (4 x 200 ml.), the combined extracts dried (MgSO_4), the ether evaporated and the residue distilled under reduced pressure to give as the main fraction, trans-pent-2-en-4-yn-1-ol (65.0 g., 41%), b.p. $80-84^\circ/20$ mm., D_{max}^{20} 3400vs (-OH), 330vs (-C \equiv CH), 2120w (-C \equiv CH), 1640m (>C=C<), 1085vs, 1035s (C-O), 990vs, 955vs (trans >C=C<) and 903m cm.^{-1} ; g.l.c. (apiezon L) at 84°N_2 2 l./hr. gave a single sharp peak (t, 6 min.).

1-Tetrahydropyranyloxy-pent-2-en-4-yne

p-Toluenesulphonic acid (ca. 0.5 g.) was added to a mixture of 2,3-dihydropyran (63.0 g., 0.75 mole) and trans-pent-2-en-yn-1-ol (41.0 g., 0.5 mole). The reaction commenced immediately upon shaking and was moderated by cooling in a cold water bath. The mixture was shaken for further 30 min., allowed to stand 1 hr., anhydrous sodium carbonate (ca. 5 g.) added, the mixture shaken, filtered and distilled to give 1-tetrahydropyranyloxy-pent-2-en-4-yne. (80.0 g., 97%), b.p. 78-80°/3 mm.

D_{\max} (I.R. 51) 3300s (C≡CH), 2120w (C≡CH), 1730vw, 1630w, 1195ms, 1175m, 1120vs, 1015vs, 870s and 814s cm.⁻¹;

λ_{\max} (U.V.11) 227 m μ (ξ , 12,990), λ_{sh} 234 m μ (ξ , 10,650);

g.l.c. (silicone oil) at 176°, N₂ 2 l./hr. gave a single peak (t, 23 min.).

n-Undecyl bromide

To a well-stirred solution of lauric acid at 60-70° (93.0 g., 0.5 mole) in 1.5 N KOH (34.0 g. in 400 ml. distilled water) was added silver nitrate solution (85.0 g., 0.5 mole in 250 ml. distilled water) over 15 min., the mixture stirred for another 15 min., the silver salt filtered, washed with methanol and dried in the oven at

70° for 1 hr. The dry silver laurate was powdered and dried in vacuo at 70°. The powdered silver laurate was suspended in 1 l. carbon tetrachloride (freshly distilled from P₂O₅) in a 2 l. 3-neck flask equipped with a condenser, dropping funnel and mechanical stirrer. The flask was cooled in ice-water and a solution of bromine (80 g., 0.5 mole) in carbon tetrachloride (200 ml.) was added over 1 hr. to the well-stirred suspension. The mixture was then heated slowly to reflux until the liberation of carbon dioxide was complete (ca. 2 hr.), the silver bromide filtered, the filtrate washed with 10% NaOH (3 x 100 ml.), water (2 x 100 ml.), the organic phase evaporated and the residue distilled under reduced pressure to give n-undecyl bromide, b.p. 135-138°/15 mm. (96.5 g., 82%); g.l.c. (silicone oil) at 176°, N₂ 1.8 l./hr. gave a single component (t, 14 min.).

1-Tetrahydropyranyloxyhexadec-2-en-4-yne

Ferric nitrate (ca. 0.1 g.) followed by lithium (3.0 g., 0.45 mole) was added with stirring to liquid ammonia (2 l.) contained in a well-lagged 3-l. flask. After stirring for further 4 hr. when the initial blue coloration had changed to greyish-white, 1-tetrahydro-

pyranyloxy-pent-2-en-4-yne (66.4 g., 0.4 mole) was added dropwise over 1 hr., the mixture stirred for 4 hr., and *n*-undecyl bromide (94.0 g., 0.4 mole) added dropwise over 1 hr. Stirring was continued for further 4 hr., the mixture allowed to stand overnight, then ammonium chloride (60 g., 0.5 mole) was added slowly and the excess ammonia allowed to evaporate, the residue extracted with ether (3 x 150 ml.), the combined extracts dried (MgSO_4), ether evaporated and the residue distilled under high vacuum, using a mercury-vapour-pump to give two fractions:- (i) b.p. $60-80^\circ/5 \times 10^{-3}$ mm. (90 g.) shown to consist of the mixture of the starting materials and (ii) b.p. $140-145^\circ/1 \text{ mm.} \times 10^{-3}$ (69 g., 57%) identified as 1-tetrahydropyranyloxy-hexadec-2-en-4-yne (Found: C, 78.7; H, 11.3; $\text{C}_{21}\text{H}_{36}\text{O}_2$ requires C, 76.8; H, 11.3%); D_{max} (I.R.52) 2030m ($-\text{C}\equiv\text{C}$) 1650w ($>\text{C}=\text{C}<$) and the characteristic tetrahydropyranyl ether bands at 1200s, 1180m, 1125s, 1022s, 870m and 825m cm.^{-1} ; λ_{max} (U.V.11) 228 μ ($\xi, 13, 200$), λ_{sh} 236 μ ($\xi, 11, 200$); g.l.c. (silicone oil) at 178° , N_2 1.8 l./hr. gave a single broad band (t, 45 min.).

Hexadec-2-en-4-yn-1-ol

1-Tetrahydropyranyloxyhexadec-2-en-4-yne (64.8 g., 0.2 mole) was dissolved in methanol/ conc. HCl ($\frac{4}{1}$ v/v) (250 ml.) and the mixture

heated under reflux for 4 hr. After cooling, the solution was neutralised with excess aqueous sodium bicarbonate solution and extracted with ether (100 ml., 3 x 50 ml.), washed with water (3 x 100 ml.), dried (MgSO_4), ether evaporated and the residue distilled under reduced pressure to give hexadec-2-en-4-yn-1-ol as the main fraction, b.p. 136-140 $\frac{0}{2}$ mm. (39.2 g., 83%) (Found: C, 81.3; H, 11.0; $\text{C}_{16}\text{H}_{28}\text{O}$ requires C, 80.8; H, 11.7%), ν_{max} (I.R.53) 3400s (-OH), 2030m ($\text{C}\equiv\text{C}$) 1650w (>C=C<) cm^{-1} ; g.l.c. (silicone oil) at 176 $^{\circ}$, N_2 1.8 l./hr. gave a major peak (t, 25 min., 85%) and two minor peaks (t, 38 min., 15%) and (t, 72 min., 5%).

Hexadeca-3,4-dien-1-ol

To a slurry of lithium aluminium hydride (10.0 g., 0.26 mole) in dry ether (500 ml.) was added dropwise over 2 hr. hexadec-2-en-4-yn-1-ol (31.0 g., 0.13 mole) in dry ether (100 ml.), the mixture refluxed for 2 hr., excess lithium aluminium hydride decomposed with cold water slowly over 1 hr. and then enough 10% hydrochloric acid added to lower the pH of the solution to 2. The ether layer was separated, the aqueous layer extracted with ether (100 ml., 2 x 50 ml.), dried (MgSO_4), ether evaporated and the residue distilled under reduced pressure to give

as the main fraction hexadeca-3,4-dien-1-ol, b.p. 120-124°/0.1 mm. (19.4 g., 63%) (Found: C, 80.8; H, 11.7; $C_{16}H_{30}O$ requires C, 80.6; H, 11.7%); ν_{max} (I.R. 54) 3400s (-OH), 1950m ($>C=C=C<$) cm^{-1} ; g.l.c. (silicone oil) at 176°, N_2 2l./hr. gave a major component (t, 62 min, 90%) and a minor component. (t, 42 min. 10%).

1-Bromo-hexadeca-3,4-diene

Triphenylphosphite dibromide¹²⁹ was prepared by the addition of bromine (16.0 g., 0.1 mole) to triphenylphosphate (31.0 g., 0.1 mole) in dry ether (200 ml.) at 0° in a weighed 500 ml. 3-neck flask equipped with a mechanical stirrer dropping funnel and calcium chloride guard-tube over 30 min., the liquid decanted, the solid washed with ether (3 x 100 ml.), dried in vacuo and the flask reweighed (37.5 g., 0.08 mole). Hexadeca-3,4-dien-1-ol (17.6 g., 0.075 mole) dissolved in dry pyridine (6.4 g., 0.08 mole) was added dropwise over 15 min. to the well-stirred solid dibromide cooled at 0° in an ice bath, and the mixture stirred for 30 min. at 0° and 1 hr. at room temperature. Ether (100 ml.) and water (150 ml.) were added to the solution, the ether layer separated, the aqueous layer extracted with ether (2 x 50 ml.), the

combined ether layer washed with 20% hydrochloric acid (3 x 50 ml.), water (2 x 50 ml.), dried (MgSO_4), ether evaporated and the residue distilled under reduced pressure to give as the main fraction 1-bromo-hexadeca-3,4-diene, b.p. $138-146^\circ/2$ mm. (11.5 g., 52%), $\mathcal{D}_{\text{max}}^{20} 1960\text{m}$ ($>\text{C}=\text{C}=\text{C}<$) cm.^{-1} ; g.l.c. (silicone oil) at 176°N_2 1.6 l./hr. gave two peaks, t, 80 min. (80%) and t, 36 min. (20%).

Octadeca-5,6-dienoic acid ("Laballenic Acid")

Sodiomalonate in absolute ethanol was prepared from sodium (1.0 g., 0.045 g. atom), and 1-bromohexadeca-3,4-diene (11.4 g., 0.037 mole) was added to it dropwise over 15 min., the mixture refluxed for 1 hr. and left overnight at room temperature. Ether (100 ml.) and water (150 ml.) were added to the mixture, the ether layer separated, the aqueous layer extracted with ether (2 x 50 ml.), the combined ether layer dried (MgSO_4) and the ether evaporated off. The crude oil (10 g.) which had $\mathcal{D}_{\text{max}}^{20} 1960\text{w}$ ($\text{C}=\text{C}=\text{C}$) cm.^{-1} was dissolved in ethanol (20 ml.), 20% aqueous caustic soda solution (50 ml.) added to it and the mixture refluxed for 1 hr. then cooled to 0° , acidified with concentrated hydrochloric acid (25 ml.) and the solution refluxed for 3 hr. The mixture was then cooled, diluted

with water (100 ml.), extracted with ether (3 x 50 ml.), ether evaporated and the residue placed on a rotary evaporator at $90-100^{\circ}/15$ mm. for 2 hr. to remove any traces of acetic acid formed from the hydrolysis and decarboxylation of excess diethyl malonate. The oily product (5.0 g.) showed $\bar{\nu}_{\max}$ (I.R. 55) $3400-2600b$ ($-COOH$), $1960w$ ($>C=C<$) and $1700s$ ($>C=O$) cm^{-1} .

Methyl octadeca-5,6-dienoate ("Methyl Laballenate")

To a solution of ~~hydrogen chloride gas (1.5 g.)~~ in methanol (25 ml.) at room temperature was added octadeca-5,6-dienoic acid (4.2 g., 0.015 mole) in methanol (10 ml.), the mixture shaken and left at room temperature overnight. Ether (50 ml.) and water (100 ml.) were added to the mixture, the ether layer separated, washed with saturated aqueous sodium bicarbonate solution (2 x 50 ml.), then water (2 x 50 ml.), dried ($MgSO_4$), ether evaporated and the residue distilled in vacuo using a mercury-vapour-pump to give methyl octadeca-5,6-dienoate, b.p. $144-146^{\circ}/5 \times 10^{-2}$ mm., (2.5 g., 56%) (Found: C, 77.3; H, 11.7; $C_{19}H_{34}O_2$ requires C, 77.5; H, 11.6%), $\bar{\nu}_{\max}$ $1960w$ ($C=C=C$) and 1750 ($>C=O$) cm^{-1} ; g.l.c. (silicone oil) at 176° , N_2 1.6 l./hr. gave one component (t, 74 min.). p-Bromophenacyl-laballenate derivative gave m.p. $46-46.5^{\circ}$ (lit.⁶⁶ m.p.

47-47.5°} (Found: C, 65.1; H, 8.0; $C_{26}H_{37}O_3Br$ requires C, 65.4; H, 7.8%). The ester (0.3 g., 0.001 mole) in ethyl acetate (50 ml.) over a catalyst (PtO_2 , 0.1 g.) absorbed hydrogen (48 ml., 0.0011 mole). Evaporation of ethyl acetate gave methyl stearate, m.p. 40° (lit.⁶⁶ m.p. 40°).

(-)-(R)-Laballenic Acid

1,2:5,6-di-O-cyclohexylidene- α -D-glucofuranose^{131,132}

Freshly redistilled cyclohexanone (140 g., 2 moles) was cooled to 0° and concentrated sulphuric acid (15 ml.) added dropwise over 5 min. with stirring followed immediately by the addition of D-glucose (180 g., 1 mole) in one portion to the well-stirred liquid. The mixture was stirred at 70-80° over a water-bath until it turned into a hard solid. n-Heptane (500 ml.) was added to the solid and the mixture stirred at 70-80° until all the solid was dissolved. The clear solution was refrigerated overnight to crystallize. The mother liquor was decanted, the solid washed with cold n-heptane (50 ml x 2) and decanted and the resultant solid was redissolved in the minimum quantity hot n-heptane, washed with hot water (3 x 100 ml.)

and refrigerated a day to crystallize, giving white crystals, m.p. 132° (130 g., 78%).

3-O-Benzyl-2,3,5,6-Di-O-cyclohexylidenyl- α -D-glucofuranose^{131,132}

1,2,5,6-Di-O-cyclohexylidene- α -D-glucofuranose (170 g., 0.5 mole) was added in one portion to a stirred mixture of freshly redistilled benzyl chloride (113 g., 1 mole) and potassium hydroxide (224 g., 4 mole). The mixture was heated to 150° on an oil-bath for 4 hr. and then allowed to attain room temperature. Water (300 ml.) was added to dissolve the potassium chloride and the mixture extracted with chloroform (200 ml.), dried (CaCl_2), solvents removed on the pump to give 3-O-benzyl-2,3,5,6-di-O-cyclohexylidene- α -D-glucofuranose as a light yellow oil (172 g., 80%).

3-O-Benzyl-1,2-cyclohexylidene- α -D-glucofuranose

3-O-benzyl-2,3,5,6-Di-O-cyclohexylidene- α -D-glucofuranose (16 g.) was dissolved in acetic acid (75% v.v. 65 ml.) and the solution stirred at $70-80^{\circ}$ for 4 hr., the acid removed on a pump and the oil redissolved in chloroform (200 g.), washed with saturated aqueous sodium bicarbonate solution (2 x 100 ml.) and water (2 x 100 ml.),

chloroform removed on the pump, the resultant oil dissolved in the minimum quantity of n-heptane and refrigerated to crystallize. The mother liquor was decanted and the thick oil distilled using a mercury-vapour-pump to give 3-O-benzyl-1,2-cyclohexylidene - α -D-glucofuranose (10 g., 76%) as a thick light yellow oil, b.p. 194-200°/3-5 x 10⁻³ mm.

(-)-Hexadeca-3,4-dien-1-ol

To a slurry of lithium aluminium hydride (6.0 g., 0.31 mole) in dry ether (500 ml.) was added dropwise over 1 hr. 3-O-benzyl-1,2-cyclohexylidene- α -D-glucosefuranose (49.1 g., 0.30 mole) dissolved in dry ether (200 ml.). The mixture was refluxed for 2 hr. then allowed to attain room temperature, and hexadec-2-en-4-yn-1-ol (17.7 g., 0.075 mole) dissolved in dry ether (100 ml.) was added to the well stirred mixture over 1 hr. at room temperature, the mixture refluxed for 2 hr., cooled in an ice-bath and decomposed slowly with water over 1 hr., and then enough 10% hydrochloric acid added to lower the pH of the solution to 2. The ether layer was separated, the aqueous layer extracted with ether (50 ml. x 3), dried (MgSO₄), ether evaporated and the residue redistilled in vacuo to give

(-)-hexadeca-3,4-dien-1-ol, b.p. 120-124°/0.1 mm. (7.8, 44%). $[\alpha]_D^{20} - 4.4^\circ$ (neat), i.r. and g.l.c. identical to the racemic form.

(-)-Octadeca-5,6-dienoic acid

"(-)-Laballenic acid" was prepared in a similar way to the racemic acid from (-)-hexadeca-3,4-dien-1-ol (7.1 g., 0.03 mole) to give (-)-Octadeca-5,6-dienoic acid (2.6 g.), $[\alpha]_D^{20} - 3.0^\circ$ (c, 25; ethanol), i.r. identical with the racemic form.

(-)-Methyl octadeca-5,6-dienoate

"(-)-Methyl laballenate" was prepared from (-)-octadeca-5,6-dienoic and (2.1 g., 0.0075 mole) as described for the racemic form to give (-)-methyl octadeca-5,6-dienoate (2.0 g.), $[\alpha]_D^{20} - 3.0^\circ$ (c, 45; ethanol), i.r. identical to its racemate.

Attempted synthesis of 8-hydroxy-octa-5,6-dienoic acid1-Tetrahydropyranyloxy-prop-2-yne

Propargyl alcohol (67.2 g., 1.2 mole) was mixed with 2,3-dihydropyran (110.0 g., 1.30 mole), cooled under ice-water and solid p-toluenesulphonic acid (0.5 g.) added, the mixture shaken and cooled under ice-water for 1 hr., left at room temperature for 2 hr., dried (Na_2CO_3), filtered and distilled, giving 1-tetrahydropyranyloxy-prop-2-yne (155.0 g., 92%), b.p. 88-90°/30 min., ν_{max} (I.R.57) 3300s ($\text{C}\equiv\text{CH}$), 2120w ($\text{C}\equiv\text{CH}$), 1220s, 1182s, 952s, 906s, 874s and 820s (tetrahydropyranyl ether) cm.^{-1} .

1-Tetrahydropyranyloxy-hex-2-yn-4-en-6-ol

A crystal of ferric nitrate was added to liquid ammonia (3.5 l.) in a well-lagged 5 l. flask, then sodium (23 g., 1 mole) added over 30 min. and the mixture stirred until the blue coloration of the solution had changed to whitish-grey (3 hr.). 1-Tetrahydropyranyloxy-prop-2-yne (140 g., 1 mole) was added dropwise over 1 hr. and the mixture stirred for 6 hr. The flask was topped up to 3.5 l. mark with liquid ammonia and epichlorhydrin (46.5 g., 0.5 mole) added dropwise over 1 hr., the mixture stirred for 4 hr. and left overnight, then decomposed with solid

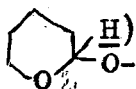
ammonium chloride (60 g.), excess ammonia evaporated off, ether (100 ml.) added, the residue filtered, washed with ether (3 x 50 ml.) filtered, the combined ether layer dried (MgSO_4), ether evaporated and the residue distilled at reduced pressure to give three fractions: (i) recovered 1-tetrahydropyranyloxy-prop-2-yne (55 g.), b.p. 44-50°/1 mm., (ii) 1-tetrahydropyranyloxy-2-furylethane (19.6 g., 20%), b.p. 120-122°/1 mm., $\bar{\nu}_{\text{max}}$ (I.R.63) 1640m ($>\text{C}=\text{C}<$), 1600m (aromatic), 1220s, 1182s, 920ms, 870ms, 820b and 730b cm.^{-1} ; λ_{max} (U.V.12) 216 $\text{m}\mu$ (ξ , 5,352) and 274 $\text{m}\mu$ (ξ , 823); g.l.c. (silicone oil) at 180°, N_2 2 l./hr. gave a single peak (t, 12 min.); hydrolysis (HCl/Methanol reflux, 3 hr.) gave 2-furylethanol b.p. 90-92°/20 mm.,¹³⁹ analogous with an authentic sample prepared by the method of Sherman and Amstutz¹³⁹, and (iii) an oily residue which upon distillation using mercury-vapour-pump gave 1-tetrahydropyranyloxy-hex-2-yn-4-en-6-ol (34.5 g., 35%) b.p. 120-122°/2 x 10⁻³ mm. (Found: C, 66.1; H, 8.0; $\text{C}_{11}\text{H}_{16}\text{O}_3$ requires C, 67.3; H, 8.2%); $\bar{\nu}_{\text{max}}$ (I.R.58) 3400s (-OH), 2230m ($-\text{C}\equiv\text{C}-$), 1640m ($>\text{C}=\text{C}<$), 1220s, 920s, 872s and 834s cm.^{-1} ; λ_{max} 227 $\text{m}\mu$ (ξ , 9,690) and 236 $\text{m}\mu$ (ξ , 8,130); N.m.r. (N.m.r.9) showed a singlet for the tetrahydropyranyl protons () at τ 6.67, a singlet for the hydroxyl proton

(-CH₂O-H) at γ 7.20, a singlet for the three equivalent methylene protons of the tetrahydropyranyl group

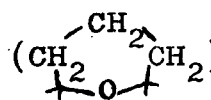
 at γ 8.32, a doublet of triplets due to the trans-olefinic proton (O-CH₂-CH=CH-C≡C-CH₂-O-) centred at γ 4.24 (J=3.0 c./sec.), a doublet for the methylene protons (~~O-CH₂~~-C≡C-CH=CH-) at γ 5.61 (J=3.0 c./sec.) and a doublet of doublets for the methylene protons (C≡C-CH=CH-CH₂-O-H) centred at γ 5.81 (J=6.0 c./sec.).

Reduction of 1-tetrahydropyranyloxy-hex-2-yn-4-en-6-ol with lithium aluminium hydride

To a slurry of lithium aluminium hydride (7.6 g., 0.2 mole) in dry ether (500 ml.) was added over 1 hr. 1-tetrahydropyranyloxy-hex-2-yn-4-en-6-ol (19.6 g., 0.1 mole) in ether (100 ml.), the mixture refluxed for 3 hr., cooled in ice and excess lithium aluminium hydride decomposed with cold water (400 ml.), the ether layer decanted, the aqueous layer extracted with ether (3 x 100 ml.), dried (MgSO₄), ether evaporated and the residue distilled giving hexa-4,5-dien-1-ol and hex-4-yn-1-ol (5.99, 60%) b.p. 50-52°/1 mm. (Found: C, 71.9; H, 10.2; C₆H₁₀O requires C, 73.5; H, 10.2%); D_{\max} (I.R. 59) 3400s (C-OH) 1960s (>C=C<), 1440_m and 8456 cm.⁻¹; g.l.c. (G.L.C.2) poly-

propylenesebacate) at 120° , H_2 8 atmospheres gave two components:- (i) t, 11 min. (30%, identified as hex-4-yn-1-ol) and (ii) t, 8 min. (70%, identified as hexa-4,5-dien-1-ol); n.m.r. (N.M.R.8) of the mixture of alcohols showed a triplet for the two protons on C_1 ($C=C=CH-\overset{4}{\underset{3}{CH_2}}$ $\overset{2}{CH_2}-\overset{1}{CH_2}-OH$) centred at $\tau 6.32$ ($J=6.0$ c./sec.) and another triplet for the two protons on C_3 ($\overset{3}{C}\equiv C-\overset{2}{CH_2}-\overset{1}{CH_2}-OH$) centred at $\tau 6.28$ ($J=6.0$ c./sec.), a singlet for the methyl protons ($\overset{3}{CH_3}-C\equiv C-CH_2-$) at $\tau 8.22$ and a multiplet for the $CH_2=C=CH-CH_2-$ system at $\tau 9.38$.

Acetate of the mixture of alcohols \overline{B} prepared from the alcohols (5.0 g., 0.05 mole), dry pyridine (4 ml.) and acetic anhydride (10.5 g.) $\overline{7}$ gave hexa-4,5-dienylacetate and hex-4-ynylacetate (4.5 g., 65%), b.p. $86-88^{\circ}/26$ mm. (Found: C, 66.9; H, 8.6; $C_8H_{12}O_2$ requires C, 68.5; H, 8.6%); g.l.c. (polypropylenesebacate) at 110° , H_2 9 atmospheres gave two components:- (i) t, 12 min. (70% identified as hexa-4,5-dienylacetate and (ii) t, 16 min. (30%, identified as hex-4-ynylacetate).

Reduction of 1-tetrahydropyranyloxy-hex-2-yn-4-en-6-ol with lithium aluminium hydride-3-O-benzyl-1,2-cyclohexylidene- α -D-glucofuranose complex

3-O-Benzyl-1,2-cyclohexylidene- α -D-glucofuranose

(35.6 g., 0.09 mole) in dry ether (100 ml.) was added over 1 hr. to a slurry of lithium aluminium hydride (3.4 g., 0.09 mole) in ether (350 ml.) and the mixture refluxed for 1 hr., allowed to cool down to room temperature and 1-tetrahydropyranyloxy-hex-2-yn-4-en-6-ol (5.2 g., 0.03 mole) in ether (100 ml.) added over 1.5 hr. The mixture was stirred at room temperature for 3 hr. then cooled in ice and decomposed with cold water (400 ml.), the ether layer decanted, the aqueous layer extracted with ether (3 x 50 ml.), the combined ether layer dried (MgSO_4), ether evaporated and the residue distilled, giving three fractions (i) b.p. 50-54°/1 mm. (1.5 g.) (ii) b.p. 80-88°/0.05 mm. (1.5 g.) and (iii) 178-190°/3 x 10⁻³ mm. (1.0 g.). Fraction (i) was identified as a mixture of hexa-4,5-dien-1-ol and hex-4-yn-1-ol. Fraction (iii) on i.r. showed ν_{max} 1950 cm, 2230 w ($-\text{C}\equiv\text{C}-$) and the characteristic tetrahydropyranyl ether bands at 1200s, 920s, 870s, and 824 cm.⁻¹ Redistillation gave (i) hexa-4,5-dien-1-ol and hex-4-yn-1-ol (0.8 g.) b.p. 54°/1 mm. (identified on g.l.c.), (ii) recovered 1-tetrahydropyranyloxy-hex-2-yn-4-en-6-ol (0.4 g.) and (iii) the residue identified by t.l.c.¹³² as the recovered 3-O-benzyl-1,2-cyclohexylidene- α -D-glucopyranose and an unidentified impurity.

Reduction of 1-tetrahydropyranyloxy-hex-2-yn-4-en-6-ol
with butane-2,3-diol-lithium aluminium hydride complex

Similarly, using butane-2,3-diol (4.5 g., 0.025 mole) in dry ether (25 ml.), lithium aluminium hydride (0.9 g., 0.025 mole) in ether (100 ml.) and 1-tetrahydro- γ -pyranyloxy-hex-2-yn-4-en-6-ol (4.9 g., 0.025 mole) in ether (25 ml.), after decomposition with water (250 ml.) and distillation, gave (i) hexa-4,5-dien-1-ol and hex-4-yn-1-ol (2.1 g.) b.p. 56-58°/ mm. (identified by i.r and g.l.c.) and (ii) residue consisting of the starting 1-tetrahydropyranyloxy-hex-2-yn-4-en-6-ol and butane-2,3-diol (2.6 g.).

δ -Chloro- γ -valerolactone

α -Carbethoxy- δ -chloro- γ -valerolactone

Sodium (23.g., 1 mole) was dissolved in absolute ethanol (400 ml.) and diethylmalonate (160 g., 1 mole) was added to the solution over 15 min. The mixture was refluxed for 1 hr., then cooled to 30-35° and epichlorohydrin (92.5 g., 78.4 ml., 1 mole) was added dropwise with brisk stirring over 30 min., the temperature of the mixture being maintained below 50° by cooling in cold water. The mixture was stirred for 12 hr. at 50-54°,

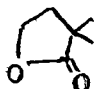
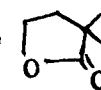
then cooled in ice-water and glacial acetic acid added until the solution was just acid to litmus (65 ml.). The mixture was distilled over an oil-bath (120°) using a 6" air column to remove most of the ethanol. Water (250 ml.) was added, the oil separated, the aqueous layer extracted with ether (MgSO₄), ether evaporated and the residue distilled giving α -carbethoxy- δ -chloro- γ -valerolactone (135 g., 65%) b.p. 154-156°/1 mm. (Found: C, 46.7; H, 5.6; Cl, 17.0; C₈H₁₁O₄Cl requires C, 46.5; H, 5.4; Cl, 17.2%), ν_{\max} (I.R.67) 1880s (lactone), 1725s (ester >C=O), and 750b (C-Cl) cm⁻¹; g.l.c. (dinonylphthalate) at 182°, N₂ 2 l./hr. gave a single peak (t, 10 min.); n.m.r. (N.M.R.4) showed a doublet for the methylene protons (ClCH₂-) at τ 6.24 (J=5 c./sec.), a quartet for the ester methylene protons ( C(=O)CH₂CH₃) at τ 5.74 (J=7.0c./sec.) and a triplet for the ester methyl protons ( COOCH₂CH₃) at τ 8.68 (J=7 c./sec.).

δ -Chloro- γ -valerolactone

α -Carbethoxy- δ -chloro- γ -valerolactone (20.7 g., 0.1 mole) was refluxed with concentrated hydrochloric acid (50 ml.) for 24 hr., cooled, the lower oil layer isolated, water (100 ml.) added to the aqueous layer, the aqueous

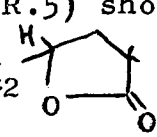
layer extracted with ether (2 x 50 ml.), the combined organic later dried (MgSO_4); ether evaporated and the residue distilled giving δ -chloro- γ -valerolactone (5.3 g., 39%), b.p. 116-118°/1.5 mm. (Found: C, 44.8; H, 5.4; Cl, 26.1; $\text{C}_5\text{H}_7\text{O}_2\text{Cl}$ requires C, 44.5; H, 5.2; Cl, 27.0%); D_{max} (I.R.68) 1780s (lactone), 1178b, 920ms and 740b (C-Cl) cm^{-1} ; n.m.r. (N.M.R.5) showed a doublet for the methylene protons (ClCH_2 ) at γ 7.6 and no signal for the ester protons.

Attempted oxidation of α -Carbethoxy- δ -chloro- γ -valerolactone¹⁴³

α -Carbethoxy- δ -chloro- γ -valerolactone (20.7 g., 0.1 mole) was dissolved in dry dimethyl sulphoxide (100 ml.), anhydrous sodium bicarbonate (10 g.) added to the solution and the mixture heated in Wood's metal bath at 150° for 5 min. Water (100 ml.) and ether (100 ml.) added, the ether layer separated, washed with water (2 x 50 ml.) and distilled, giving recovered α -carbethoxy- δ -chloro- γ -valerolactone (18.5 g.)

The mixture of silver tosylate¹⁴³ (40 g.), α -carbethoxy- δ -chloro- γ -valerolactone (20 g.) and sodium bicarbonate (10 g.) in dimethyl sulphoxide (100 ml.) also gave, after working up, the recovered chlor-lacton-ester (16 g.).

Similarly, the iodo-lacton-ester [prepared¹⁴⁶ from α -carbethoxy- δ -chloro- γ -valerolactone (20 g.), sodium iodide (30 g.) and acetone (200 ml.) refluxed for 12 hr.] (10 g.), dimethyl sulphoxide (100 ml.) and sodium bicarbonate (5 g.) also gave recovered iodo-lacton-ester.

INFRA-RED SPECTRA

Infra-red Spectra:

<u>No.</u>	<u>Index</u>	<u>Page</u>
1	3-Ethyl-penta-1,2-diene	211
2	3-Methyl-octa-1,2-diene	211
3	3,4,4-Trimethyl-penta-1,2-diene	211
4	1,1-Dichloro-2,2-dimethyl-3-methylene-cyclopropane	212
5	1,1-Dichloro-2-methyl-2-ethyl-3-methylene-cyclopropane	212
6	1,1-Dichloro-2,2-diethyl-3-methylene-cyclopropane	212
7	1,1-Dichloro-2-n-propyl-3-methylenecyclopropane	213
8	1,1-Dichloro-2-methyl-2-n-pentyl-3-methylene-cyclopropane	213
9	1,1-Dichloro-2-methyl-2-t-butyl-3-methylene-cyclopropane	213
10	1,1-Dibromo-2,2-dimethyl-3-methylenecyclopropane	214
11	1,1-Dibromo-2-methyl-2-ethyl-3-methylene-cyclopropane	214
12	1,1-Dibromo-2,2-diethyl-3-methylenecyclopropane	214
13	4-Methyl-penta-1,2,3-triene	215
14	4-Methyl-hexa-1,2,3-triene	215
15	4-Ethyl-hexa-1,2,3-triene	215
16	Diethyl allyl-1-butenylmalonate	216
17	Diethyl 2-ethyl-pent-1,4-enylidenemalonate	216
18	Diethyl propargyl-1-butenylmalonate	216
19	Diethyl 2-ethyl-penta-3,4-dienylidenemalonate	217

<u>No.</u>	<u>Index</u>	<u>Page</u>
20	Diethyl-propargyl-eth e nylmalonate	217
21	Diethyl propargyl-1-n-propenylmalonate	217
22	Diethyl propargyl iso-propenylmalonate	218
23	Diethyl-1-methyl-penta-3,4-dienylidene-malonate	218
24	Diethyl 1-methyl-1-n-propenylmalonate	218
25	Diethyl 1,2-dimethyl-penta-3,4-dienylidene-malonate	219
26	Diethyl propargyl-isobutenylmalonate	219
27	Diethyl 2,2-dimethyl- ^{penta-} 3,4-dienylidene-malonate	219
28	Methyl methacrylate	220
29	Methyl 1-methylcyclopropane-1-carboxylate	220
30	Ethyl <u>trans</u> -2-methylcyclopropane-1-carboxylate	220
31	Ethyl <u>trans</u> -2-n-propylcyclopropane-1-carboxylate	221
32	Ethyl <u>trans</u> -cinnamate	221
33	Ethyl <u>trans</u> -2-phenylcyclopropane-1-carboxylate	221
34	Mesityl oxide	222
35	2,2-Dimethylcyclopropane-methyl-ketone	222
36	Ethyl <u>trans-trans</u> -penta-2,4-dienoate	222
37	Ethyl 2-vinylcyclopropane-1-carboxylate	223
38	Ethyl <u>trans-trans</u> -sorbate	223
39	Ethyl 2,3-methylene-hex-4-enoate	223
40	Ethyl 2,3-methylene-hexanoate and 2,3-4,5-dimethylene hexanoate (50-50% mixture)	224

<u>No.</u>	<u>Index</u>	<u>Page</u>
41	Diethyl fumarate	224
42	Diethyl <u>trans</u> cyclopropane-1,2-dicarboxylate	224
43	Diethyl 2-methylcyclopropane-1,1-dicarboxylate	225
44	Diethyl 2,2-dimethylcyclopropane-1,1-dicarboxylate	225
45	Diethyl 2-ethylcyclopropane-1,1-dicarboxylate	225
46	Diethyl isobutylidenemalonate	226
47	Diethyl 2-isopropylcyclopropane-1,1-dicarboxylate	226
48	Diethyl 2-phenylcyclopropane-1,1-dicarboxylate	226
49	Ethyl buta-2,3-dienoate	227
50	Dimethylsulphoxonium 3-ethoxycarbonyl-2-methylallylide	227
51	1-Tetrahydropyronyloxy-pent-2-en-4-yne	227
52	1-Tetrahydropyranlyoxy-hexadec-2-en-4-yne	228
53	Hexadec-2-en-4-yn-1-ol	228
54	Hexadeca-3,4-dien-1-ol	228
55	Octadeca-5,6-dienoic acid ("Laballenic acid")	229
56	Methyl octadeca-5,6-dienoate ("Methyl laballenate")	229
57	1-Tetrahydropyranlyoxy-prop-2-yne	229
58	1-Tetrahydropyranlyoxy-hex-2-yn-4-en-6-ol	230
59	Hexa-4,5-dien-1-ol and hex-4-yn-1-ol (7D:30%)	230
60	Penta-3,4-dien-1-ol	230

<u>No.</u>	<u>Index</u>	<u>Page</u>
61	Hexa-4,5-dienyl acetate and hexa-4-ynyl acetate (70:30%)	231
62	Mixture of 58 and 59	231
63	1-Tetrahydropyranyloxy-2-furylethane	231
64	Hex-1-en-5-yne	232
65	1,3-Dibromo-prop-1-yne	232
66	Ethyl 4,5-methylene-hex-2-enoate	232
67	δ -Chloro- α -carbethoxy- γ -valerolactone	233
68	δ -Chloro- γ -valerolactone	233
69	γ -Butyrolactone	233

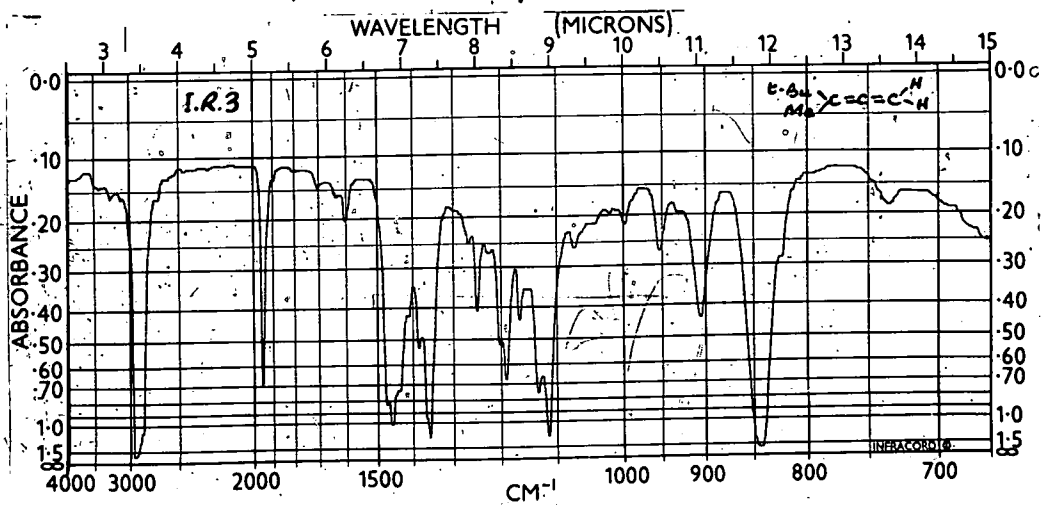
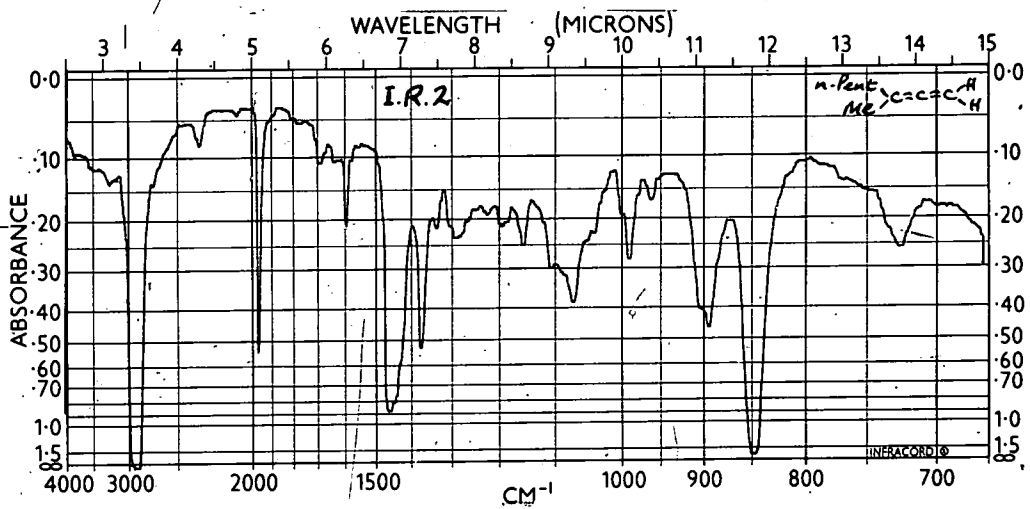
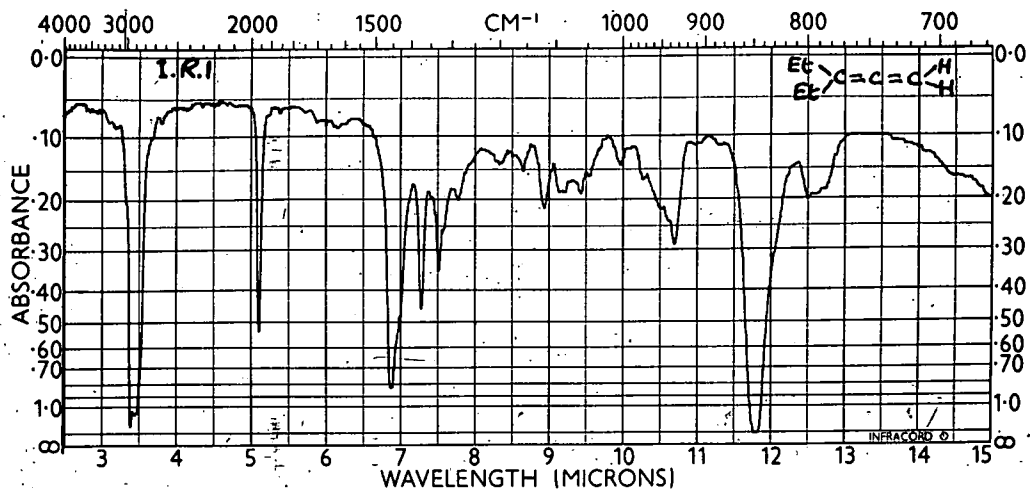

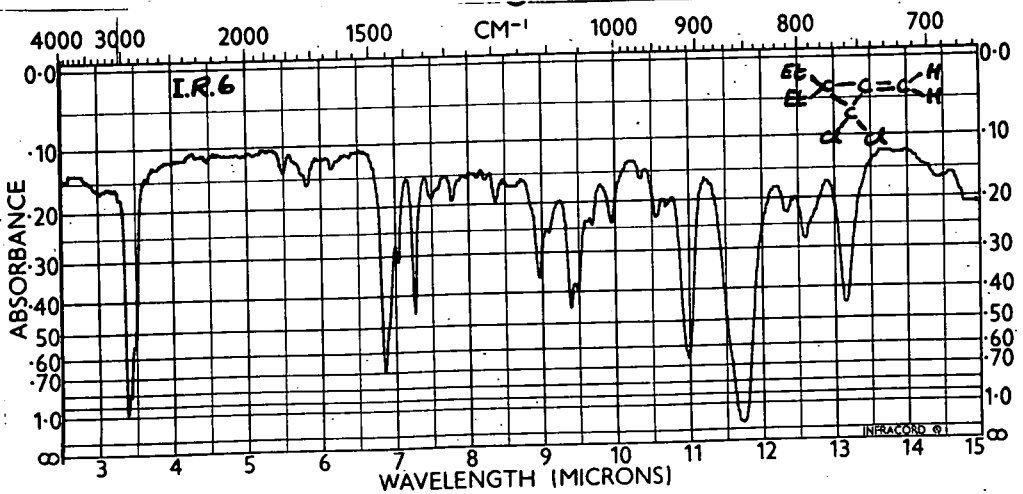
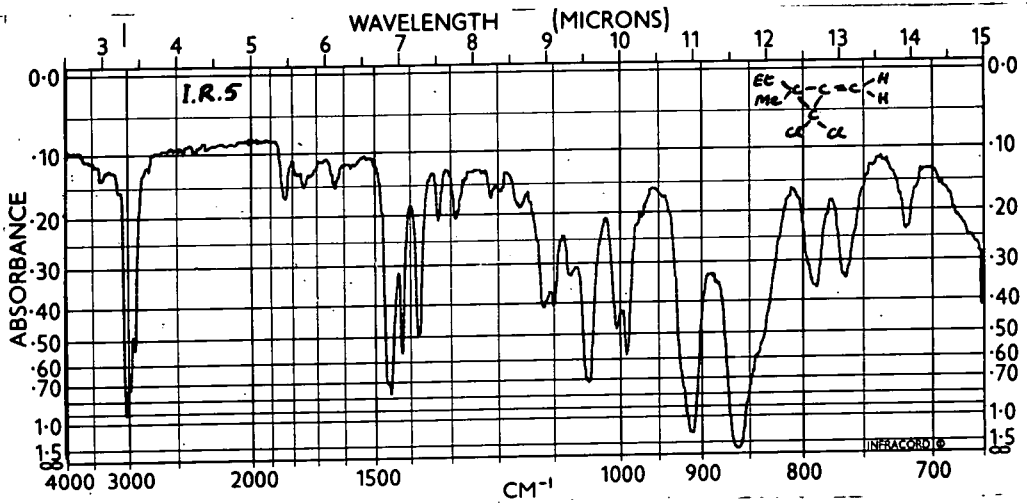
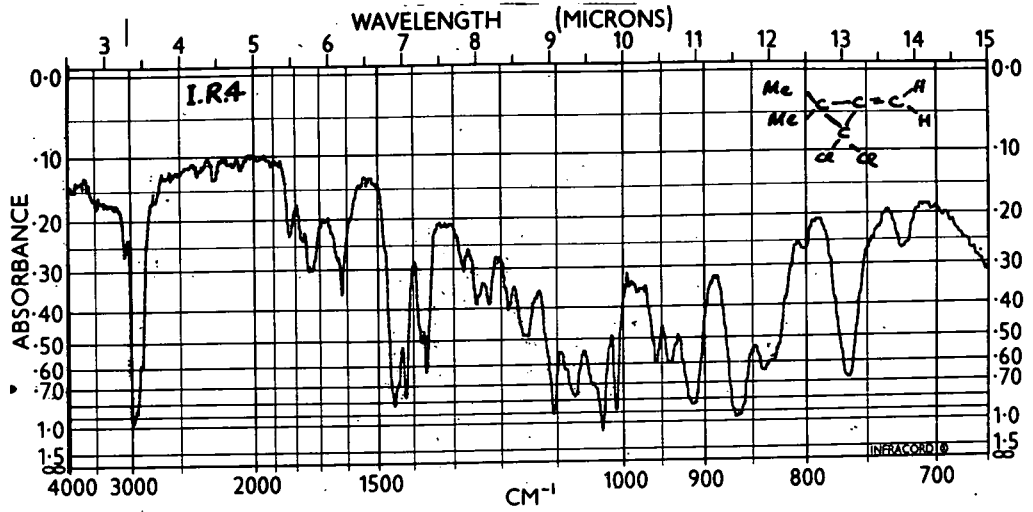

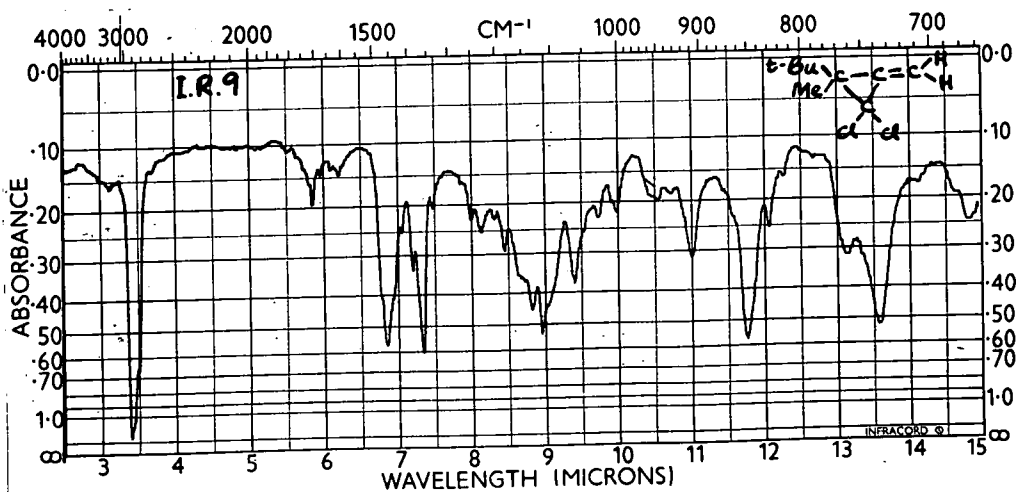
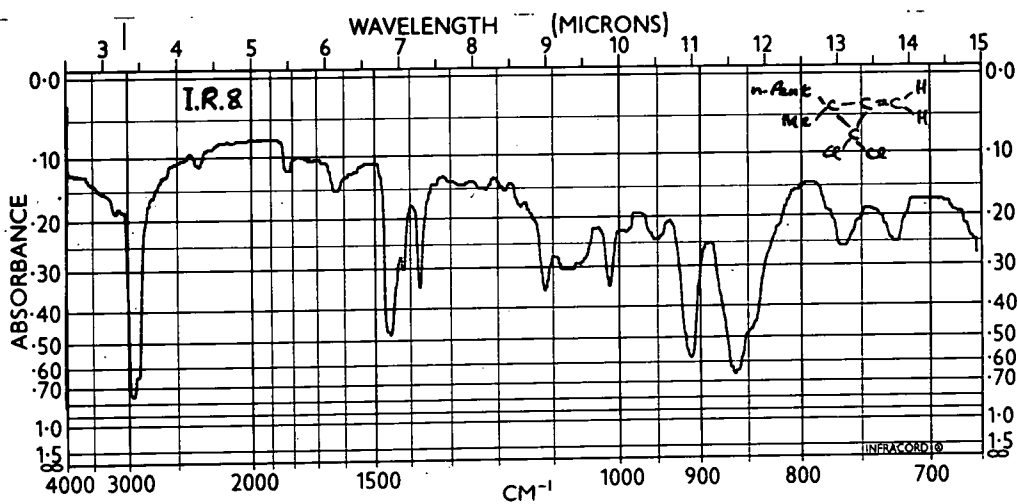
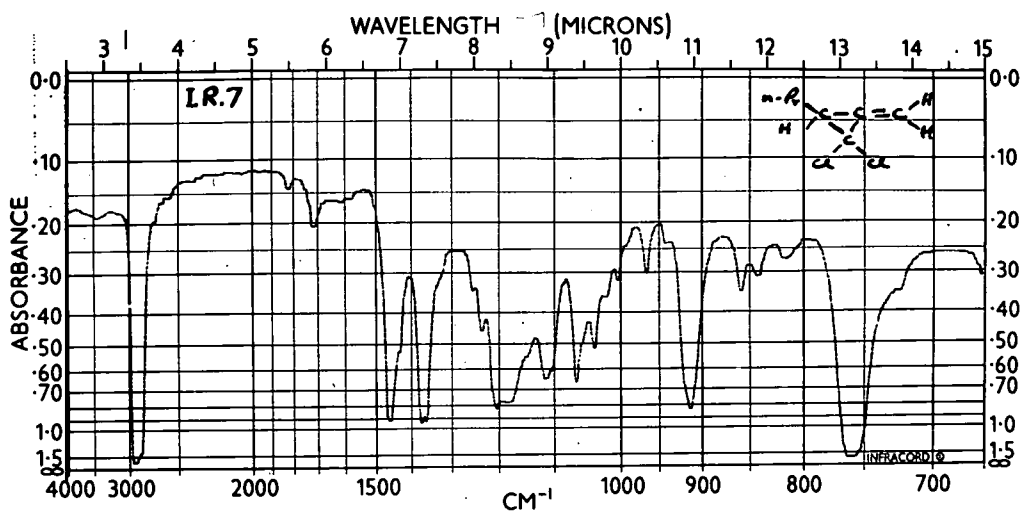

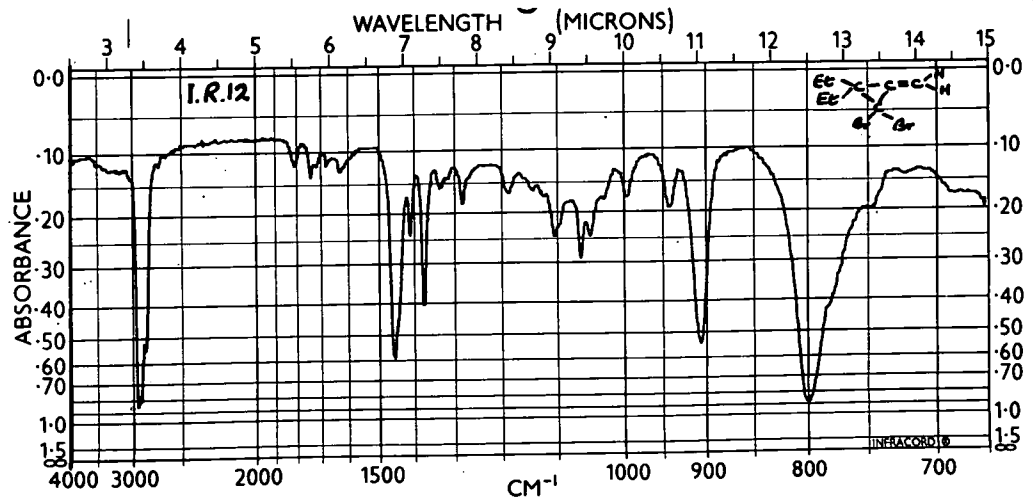
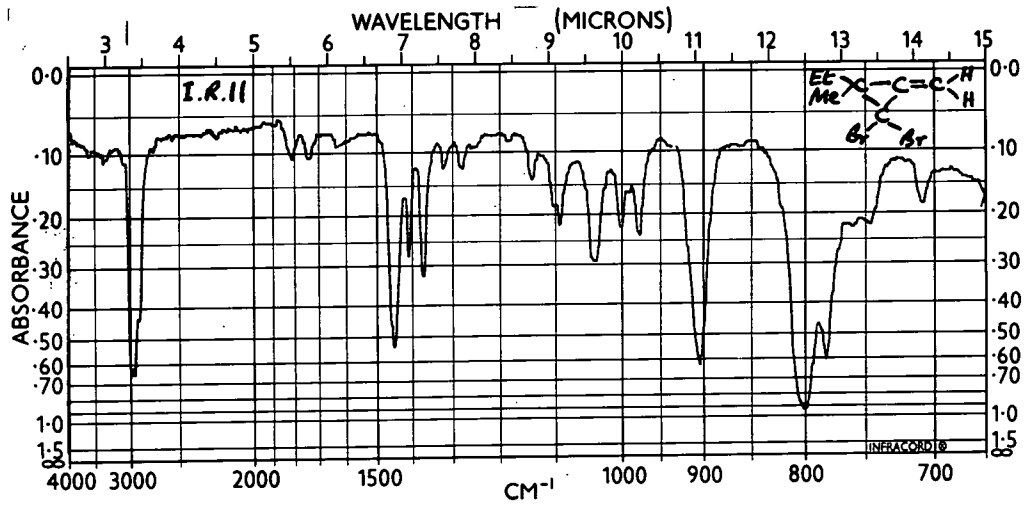
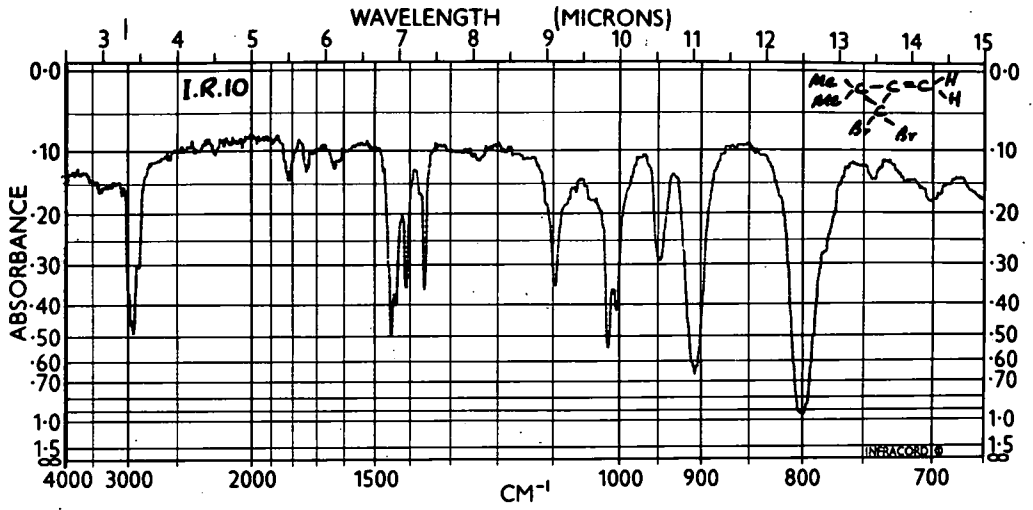

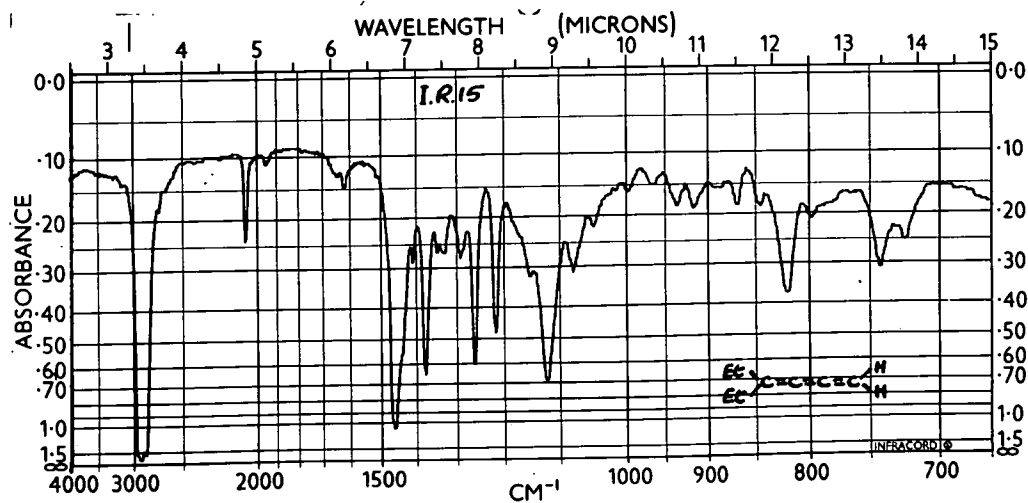
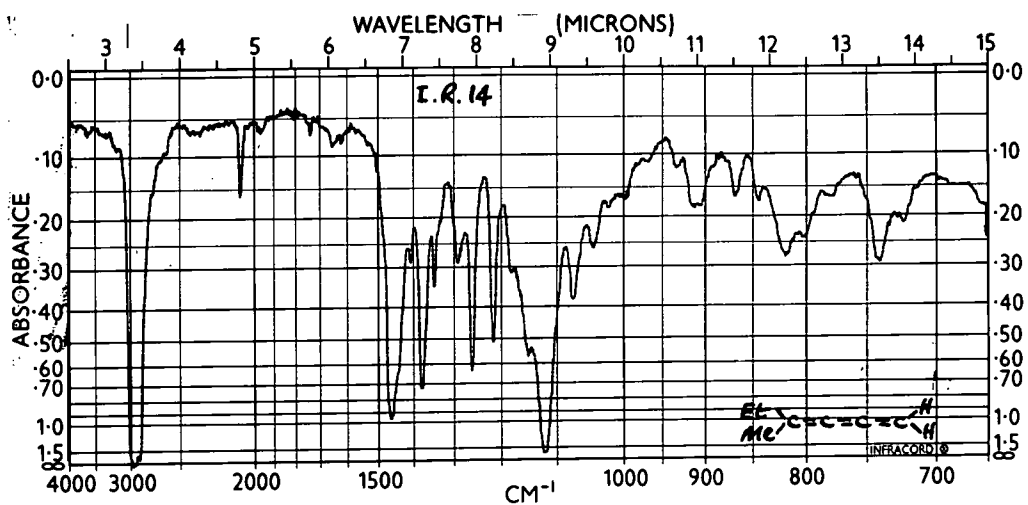
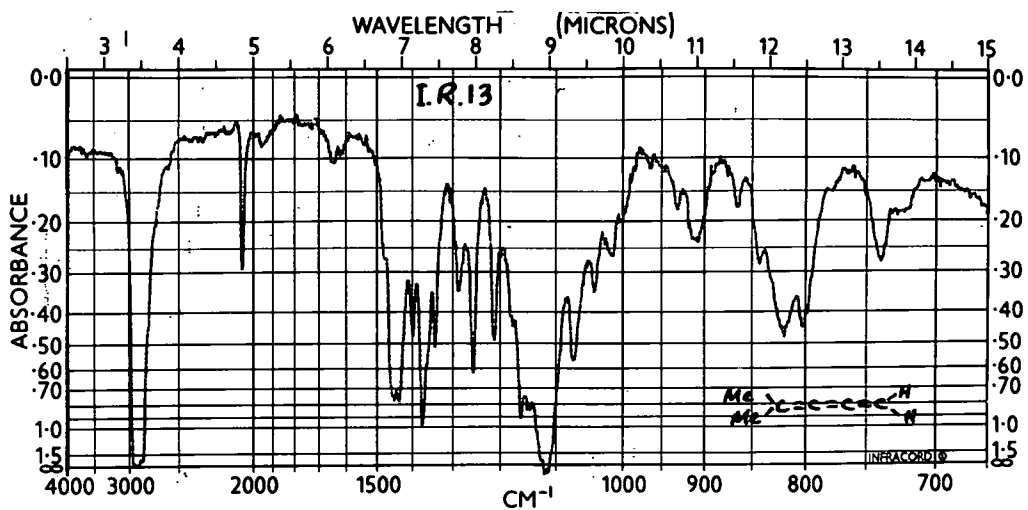

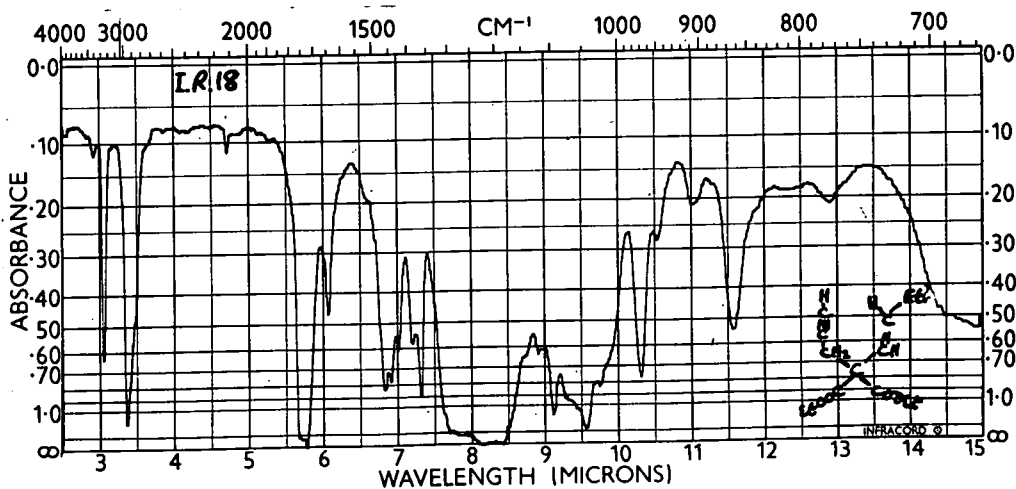
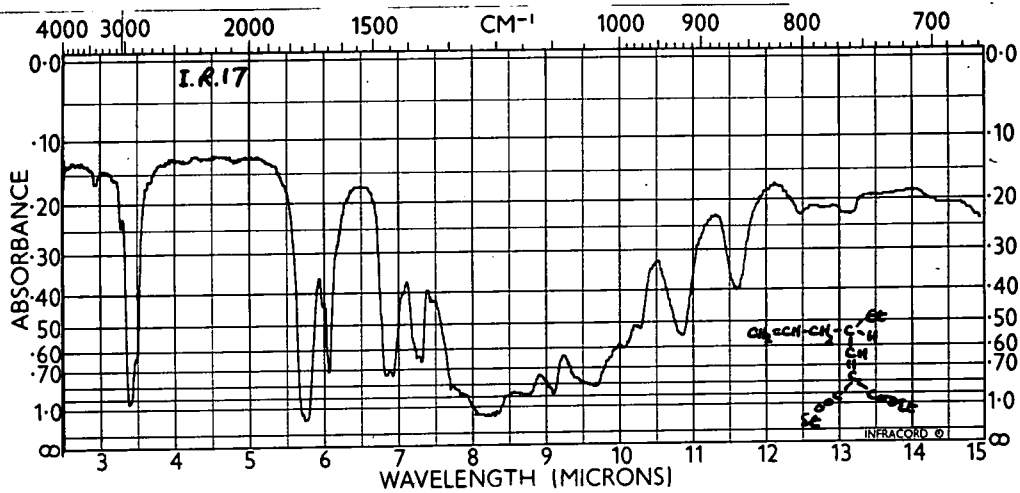
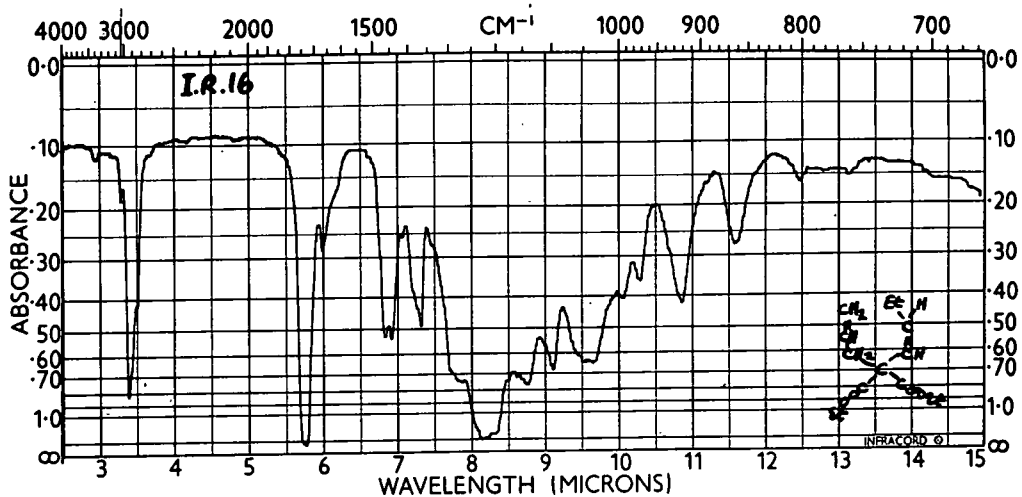

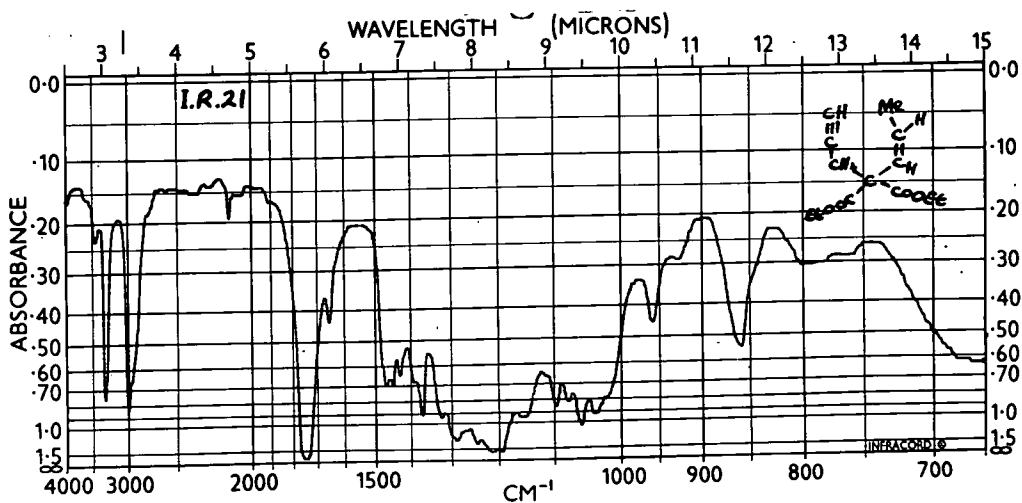
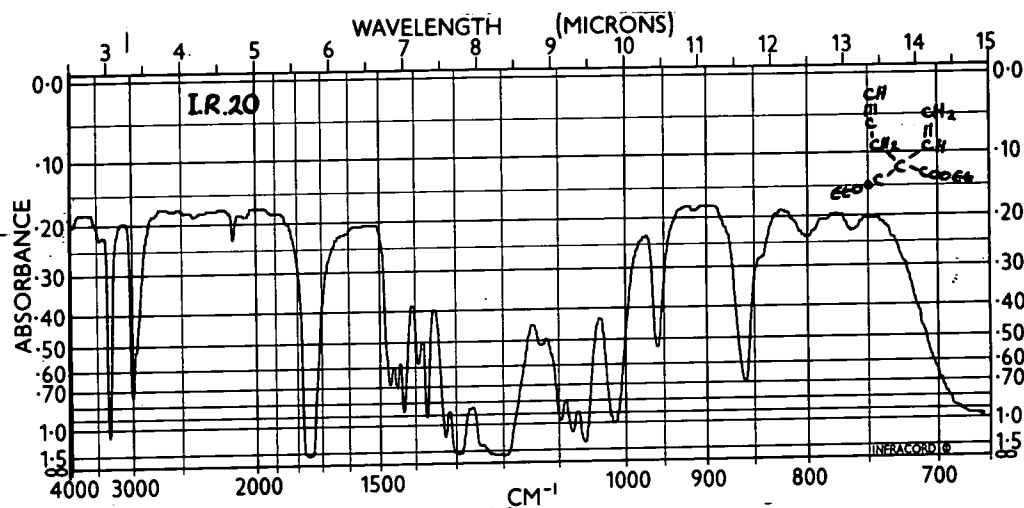
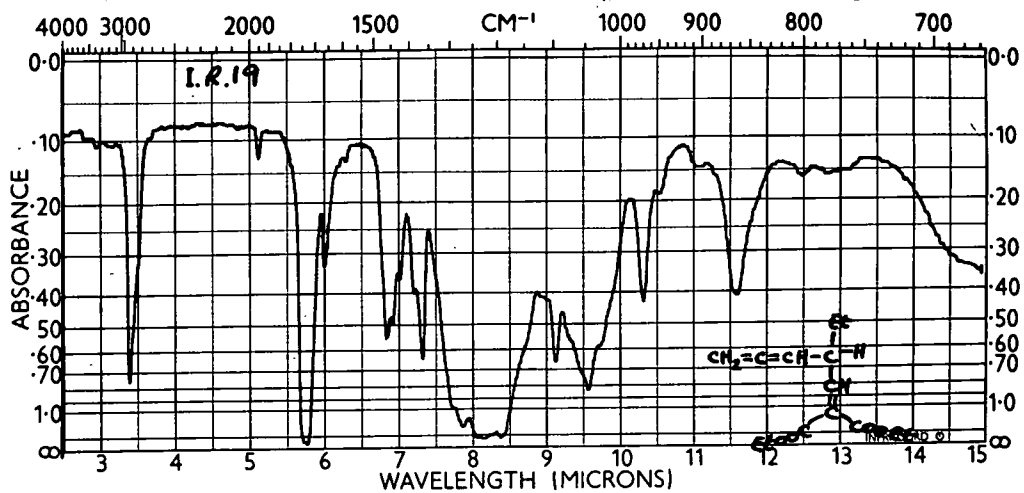

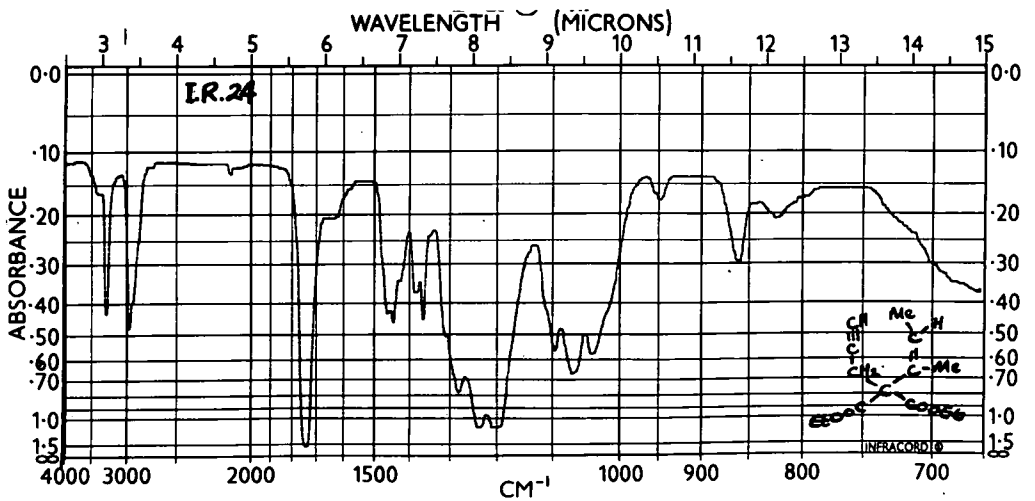
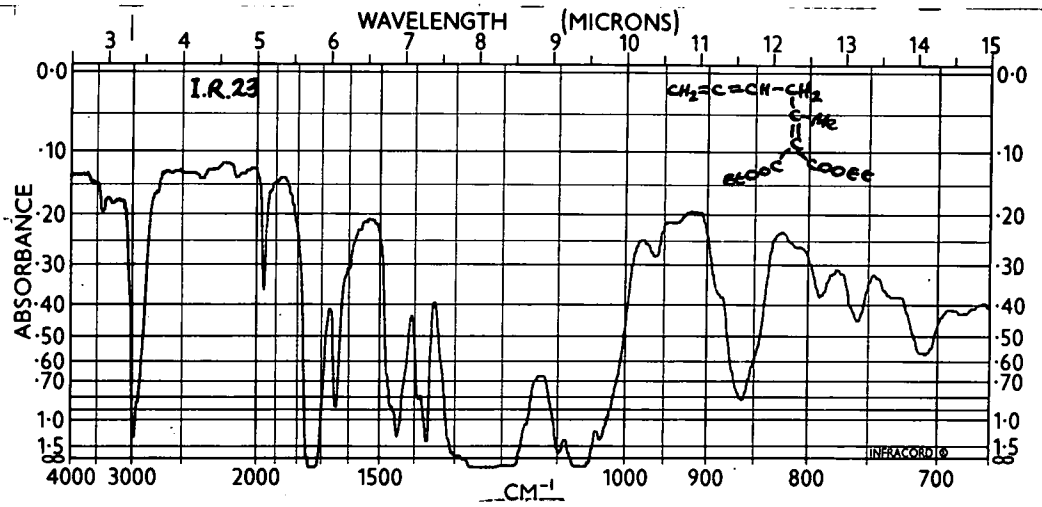
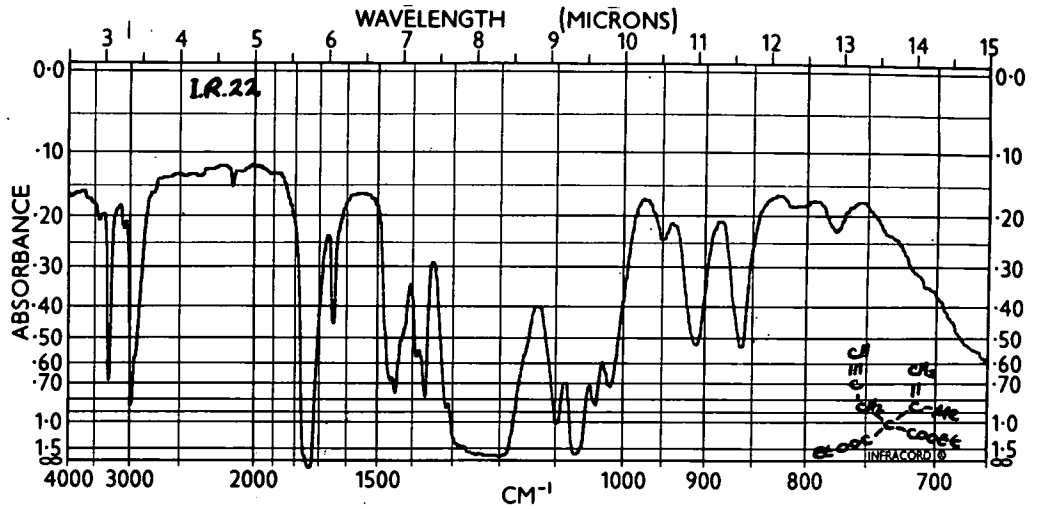

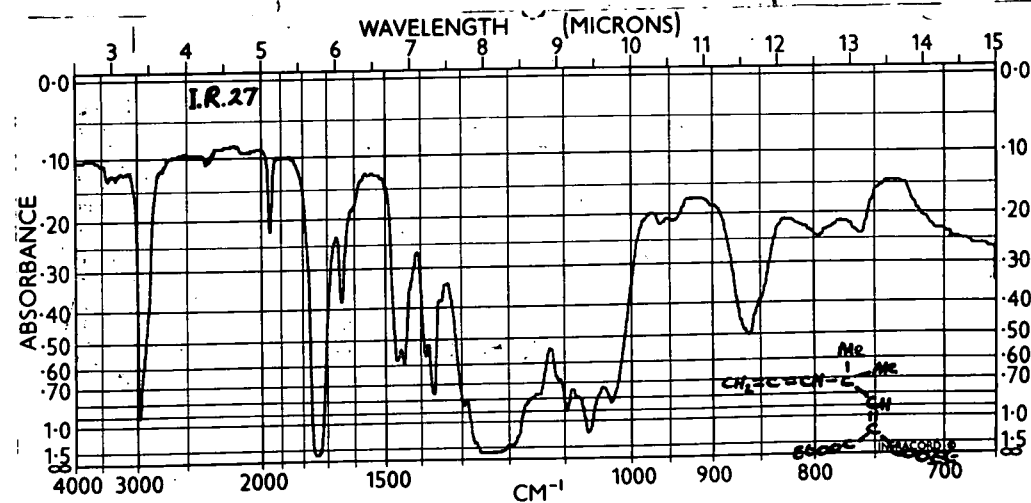
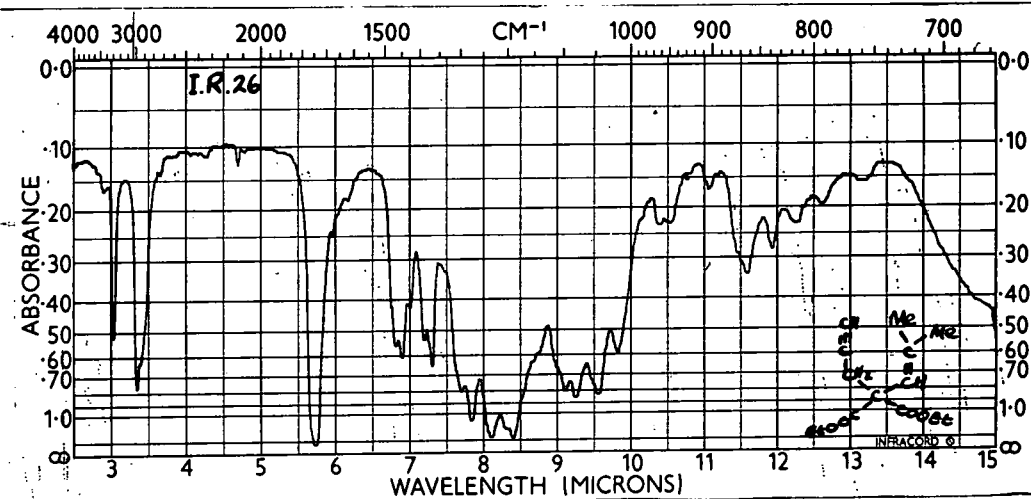
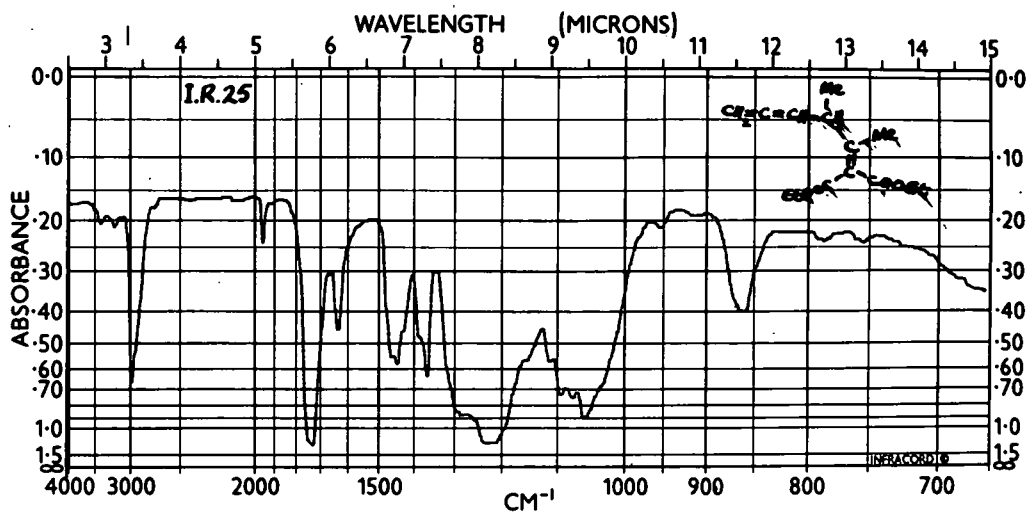

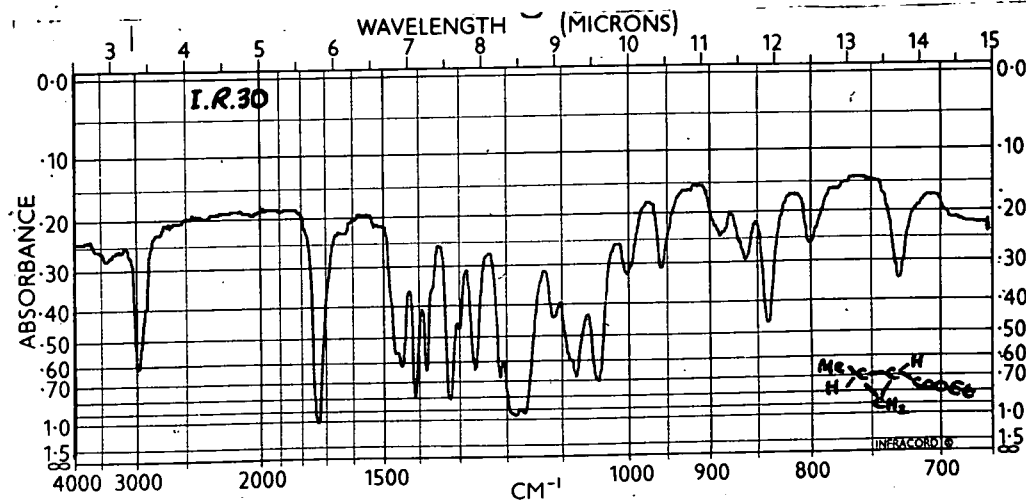
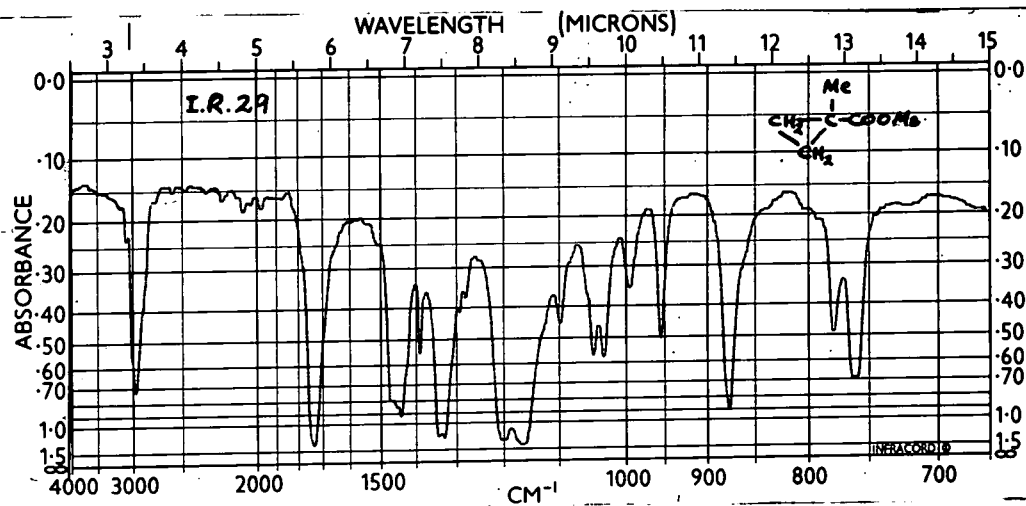
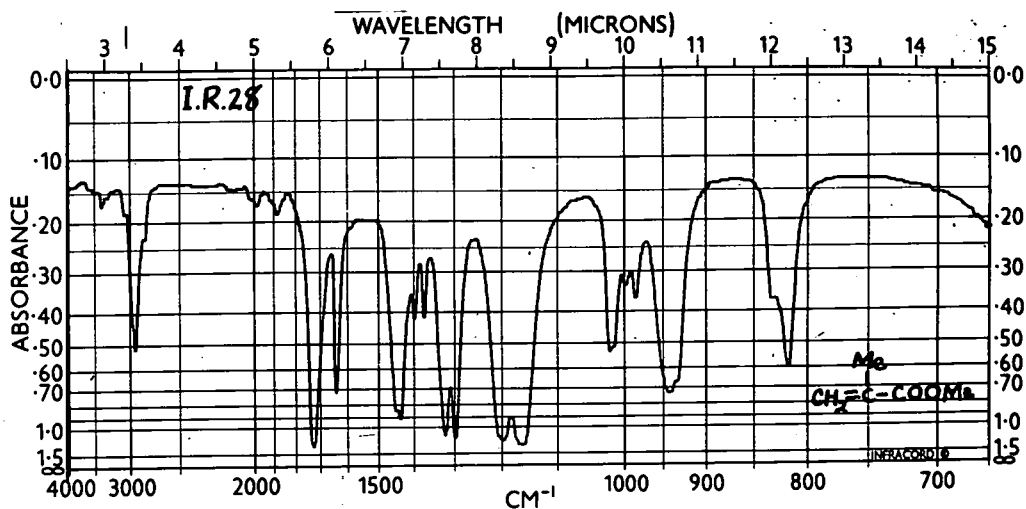

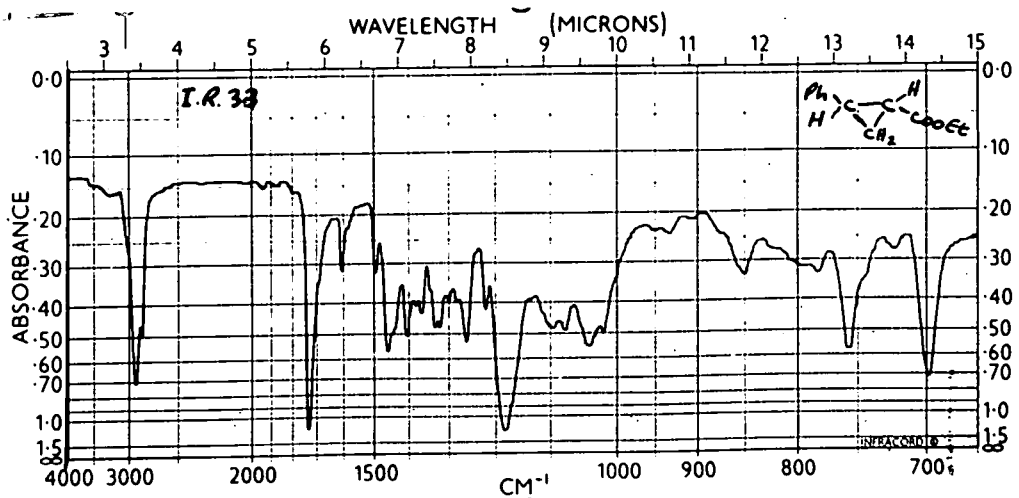
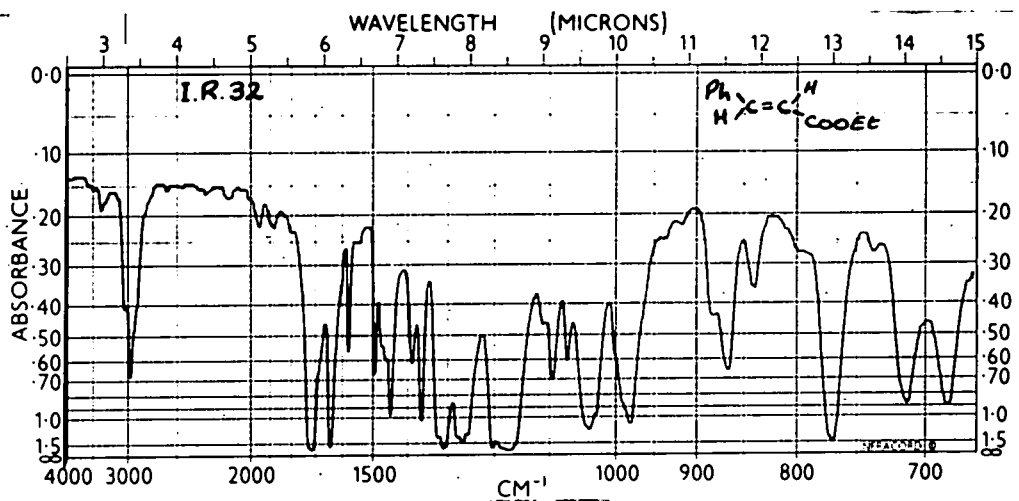
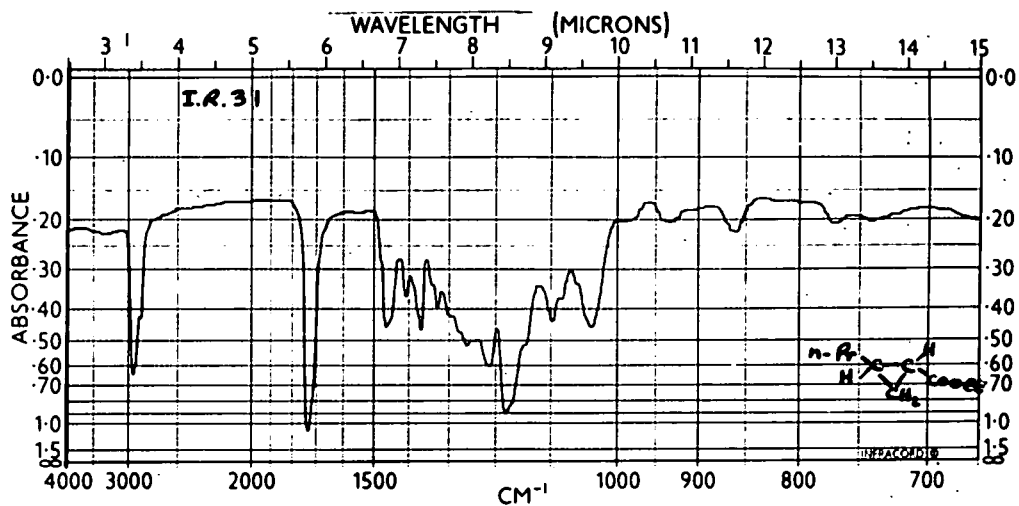

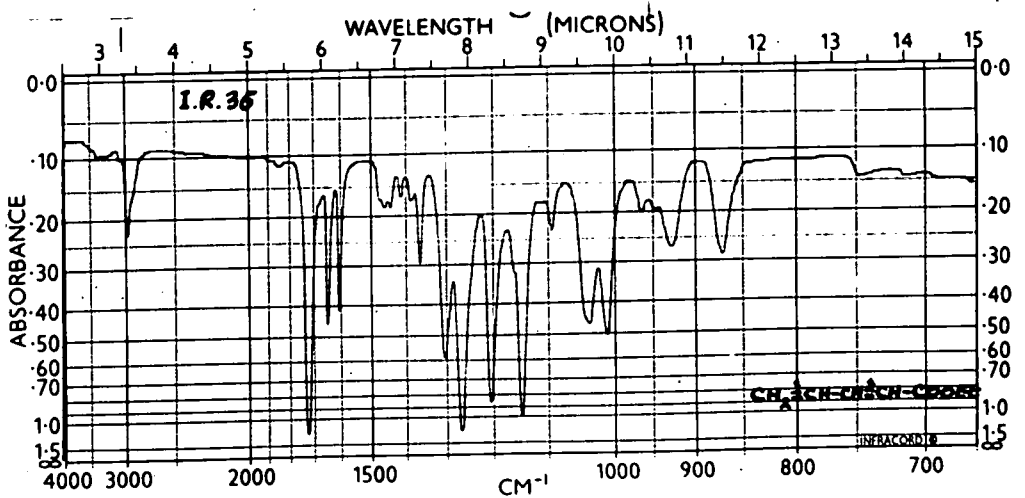
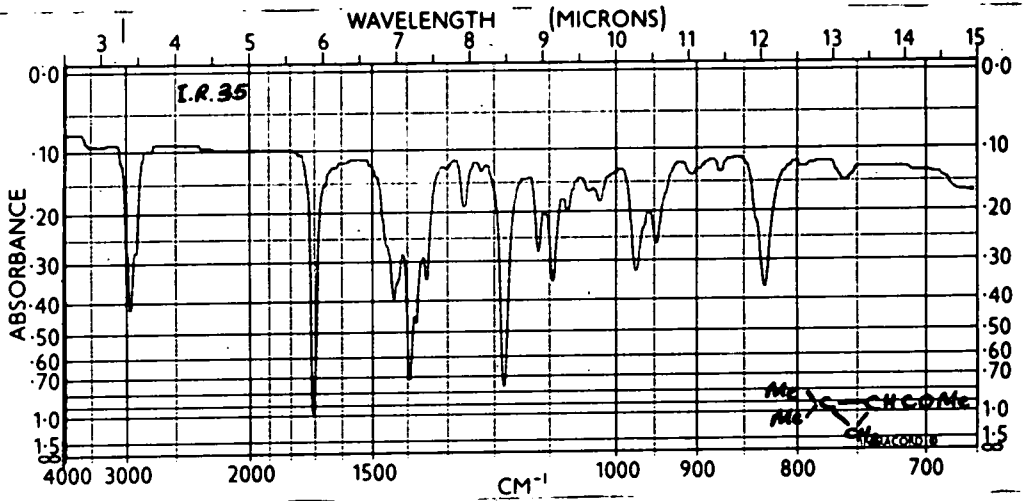
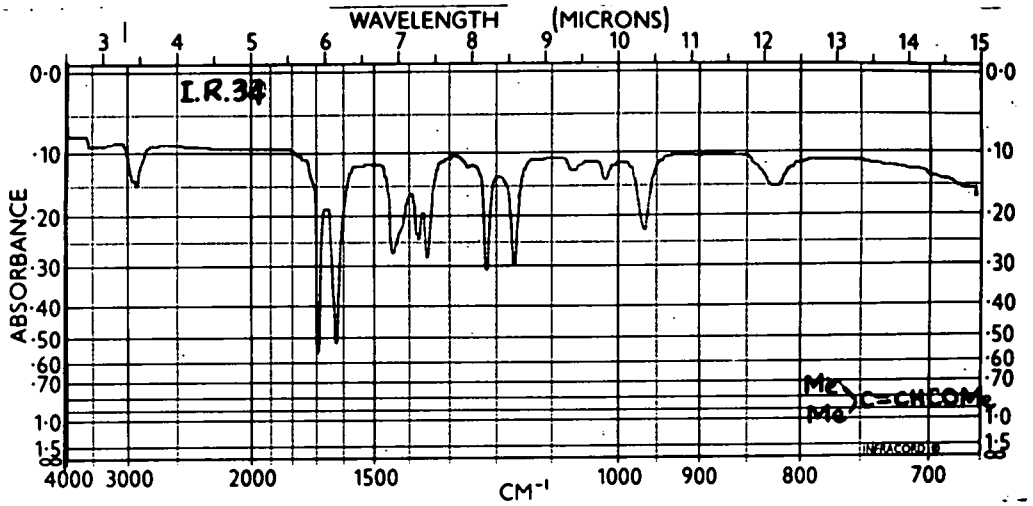

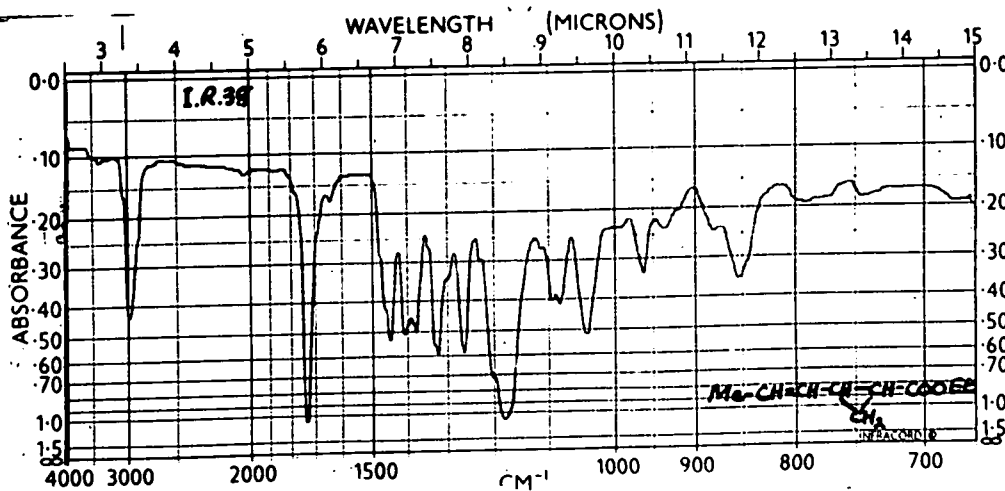
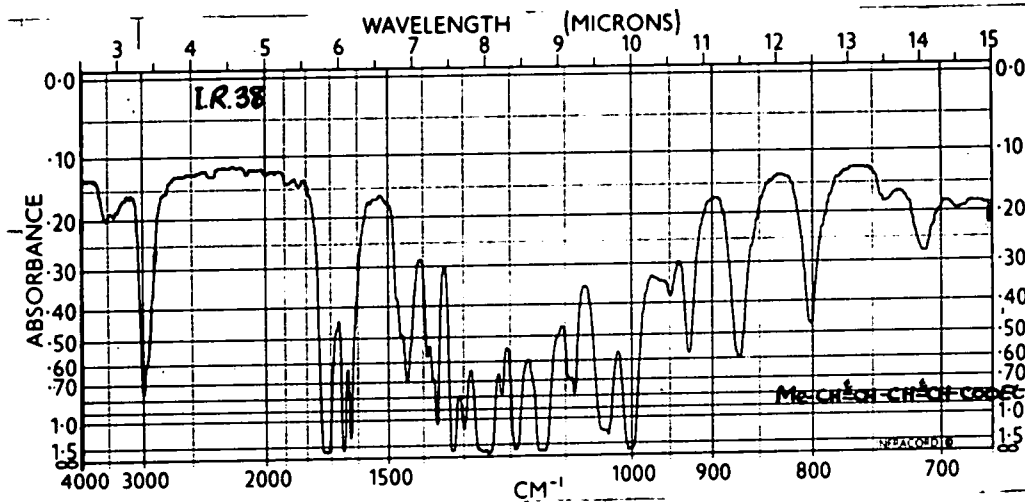
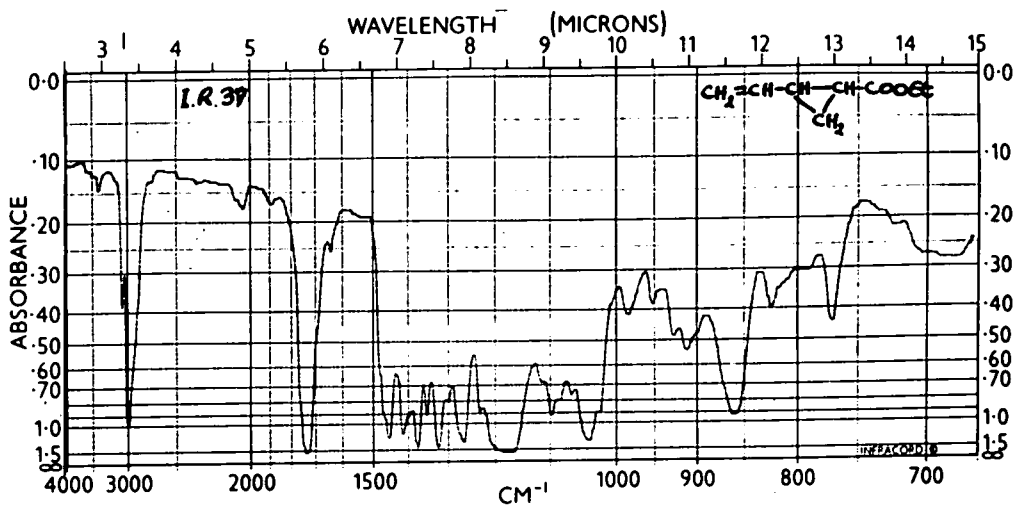

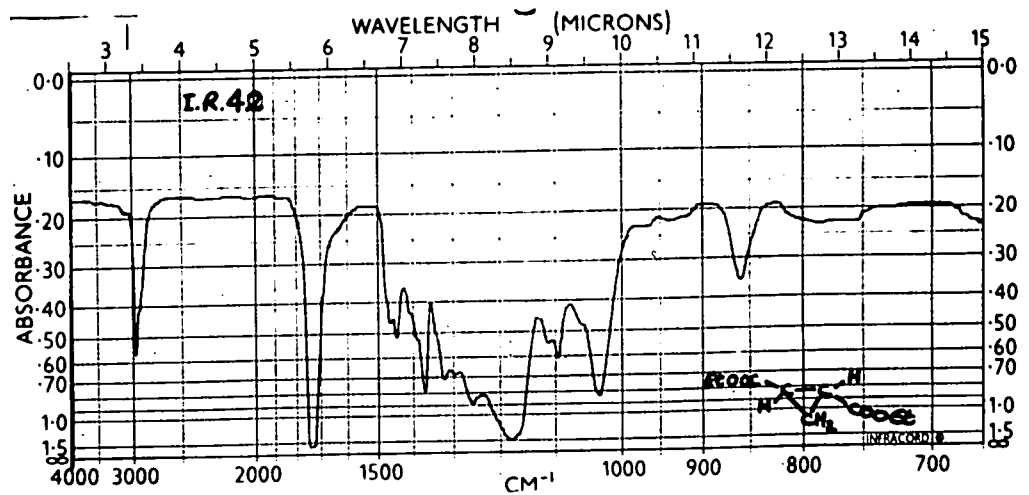
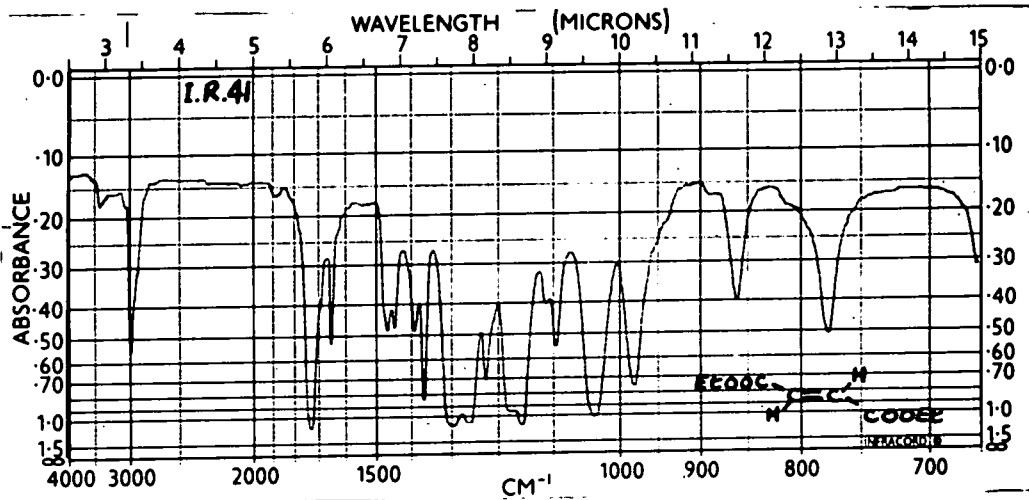
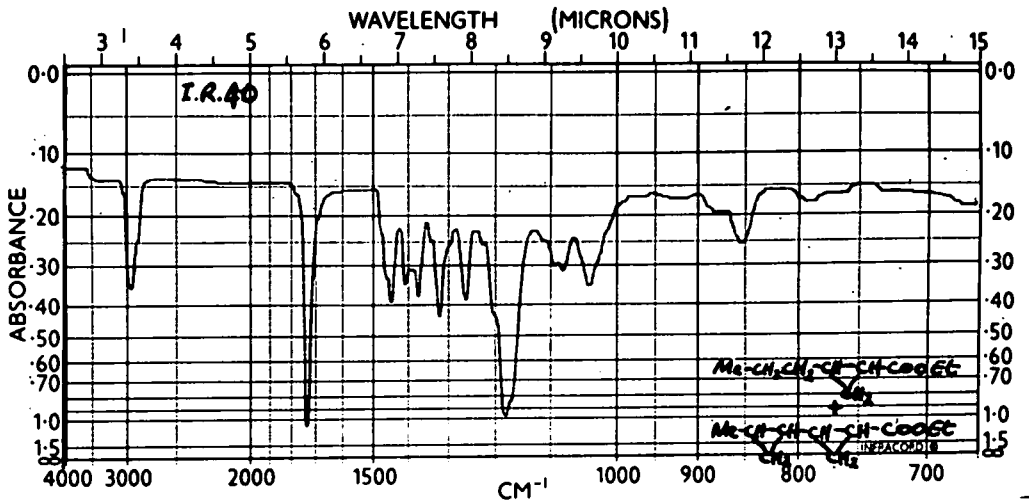

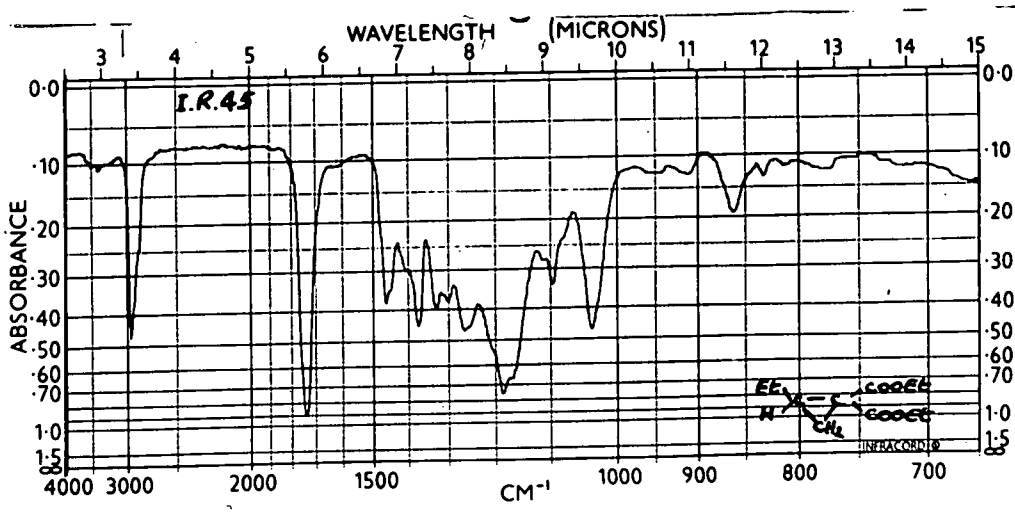
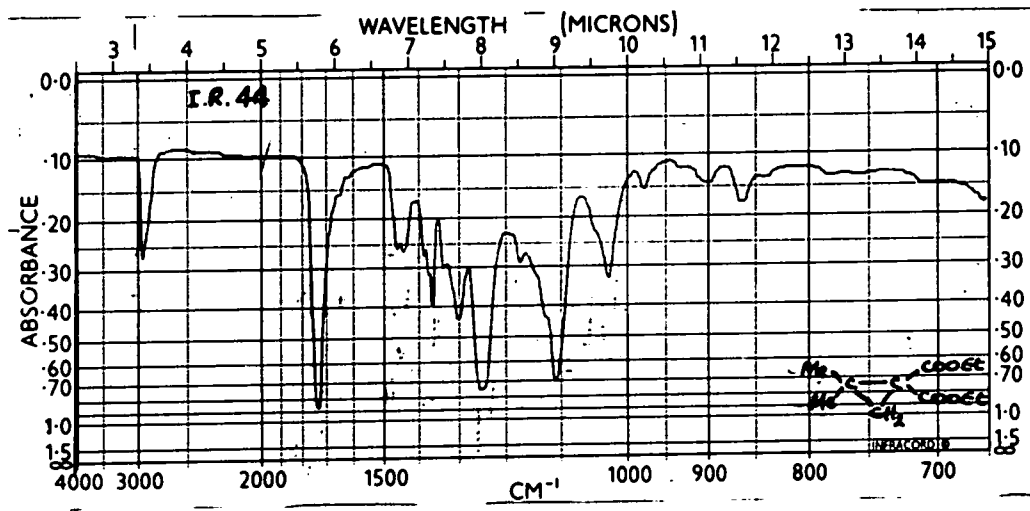
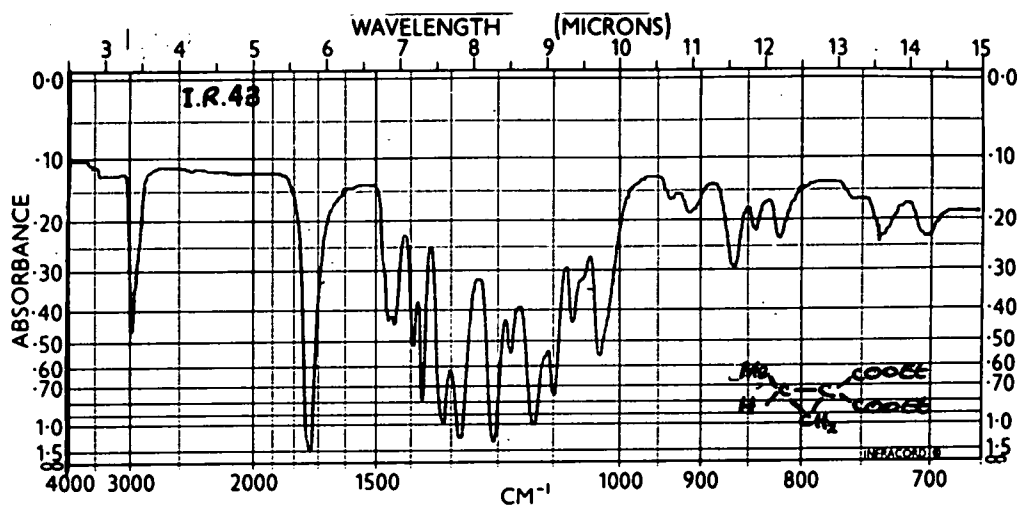

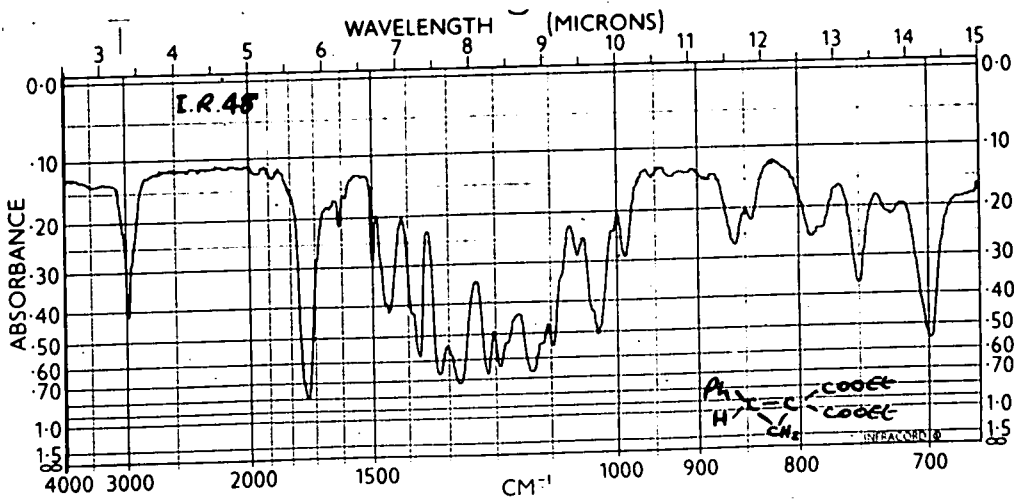
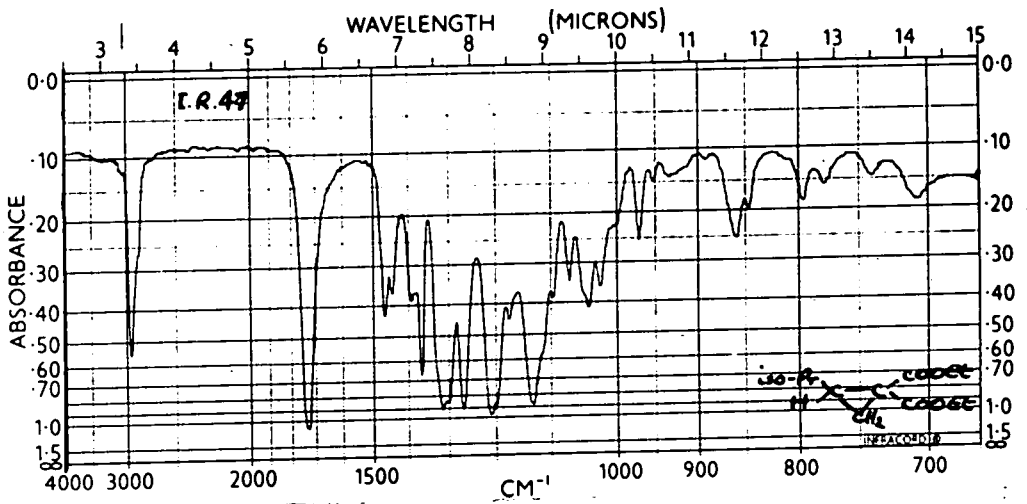
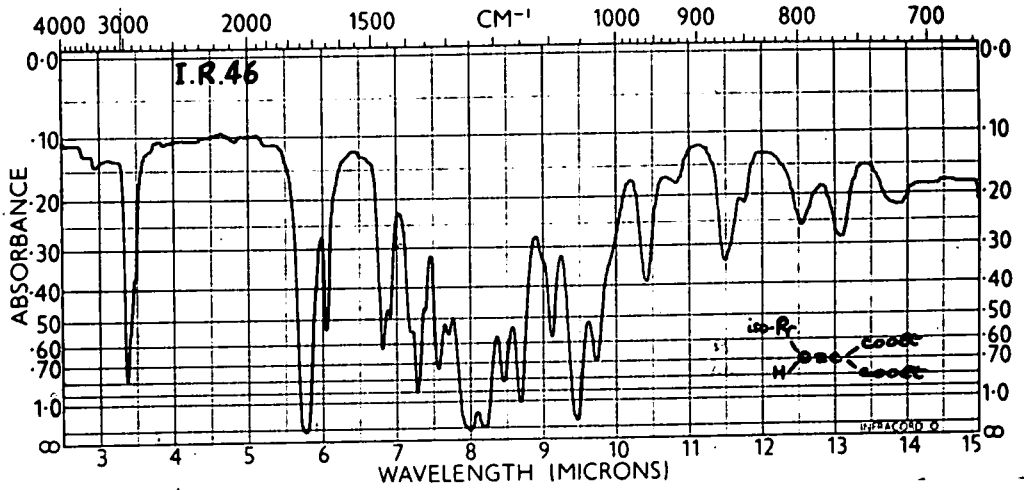

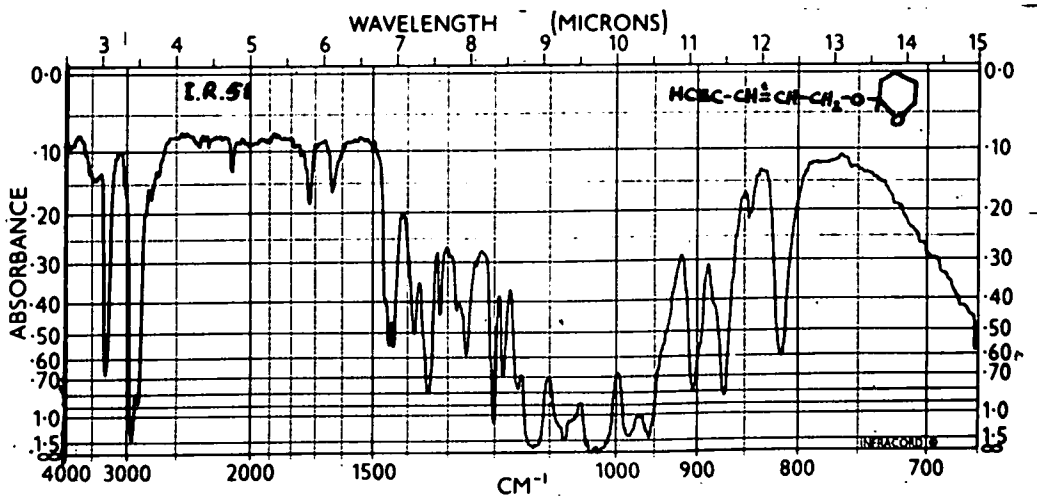
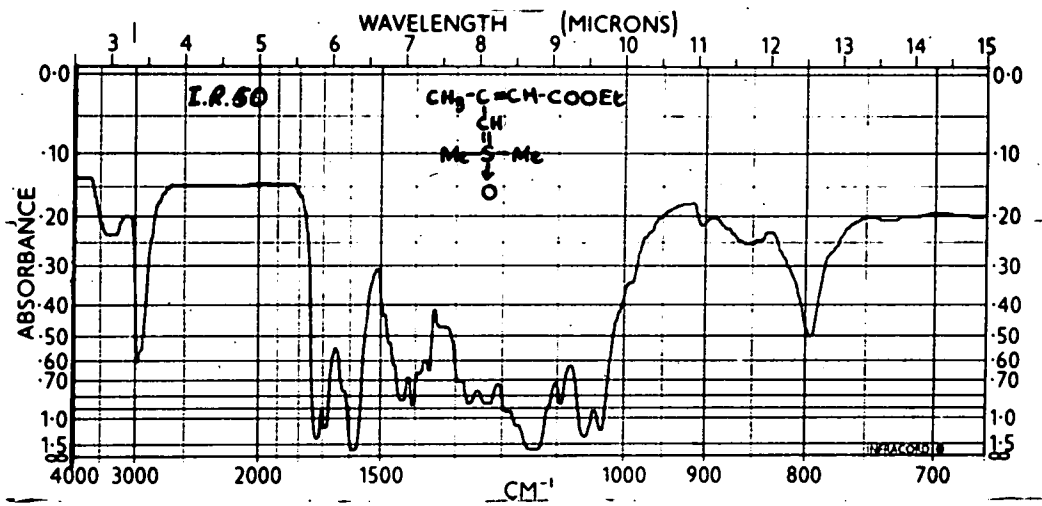
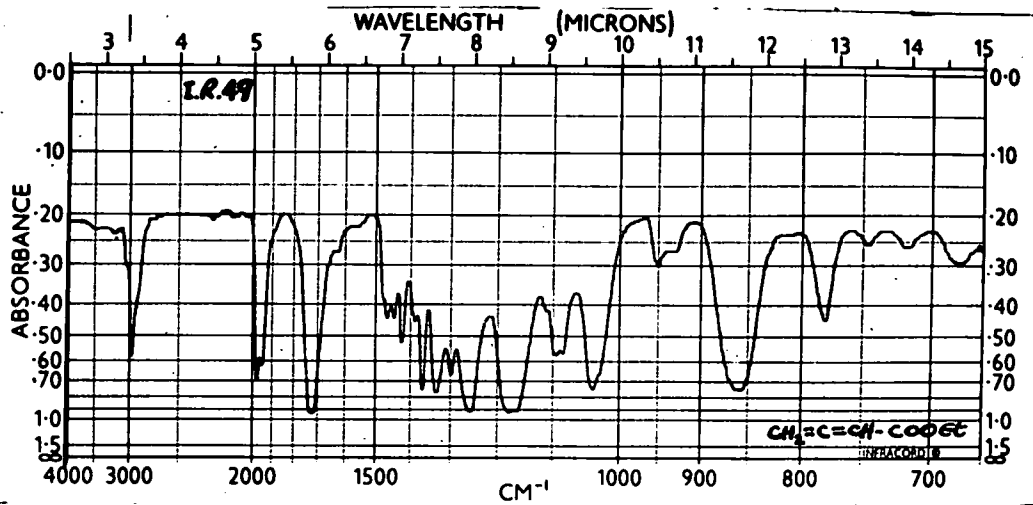

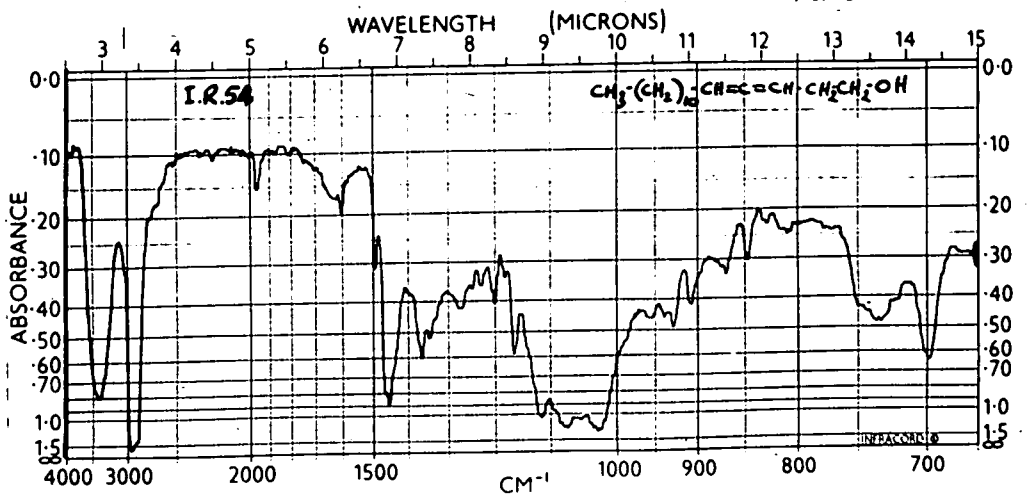
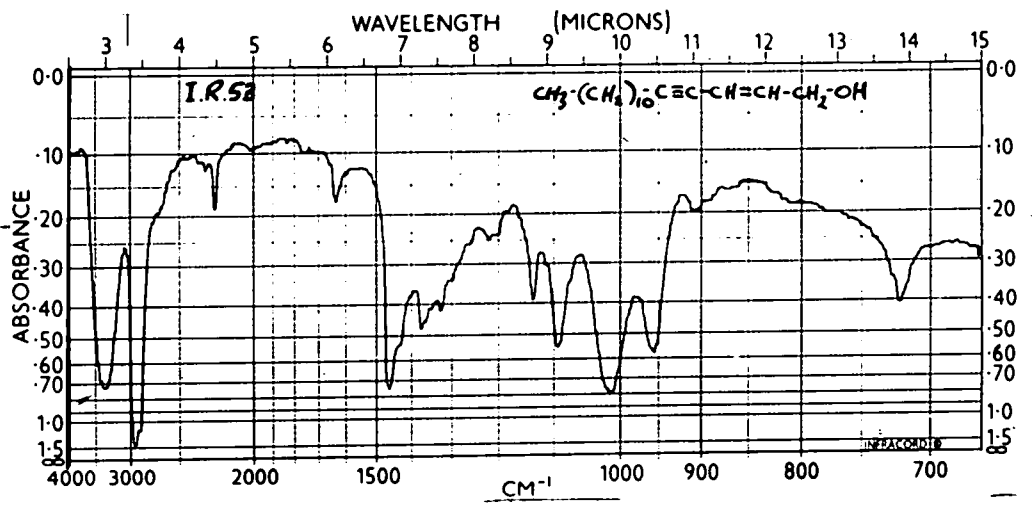
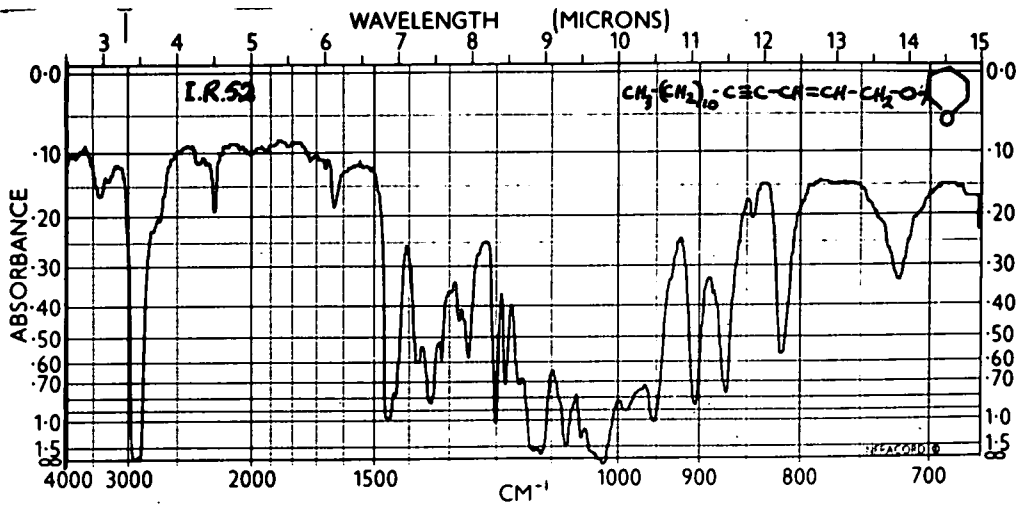

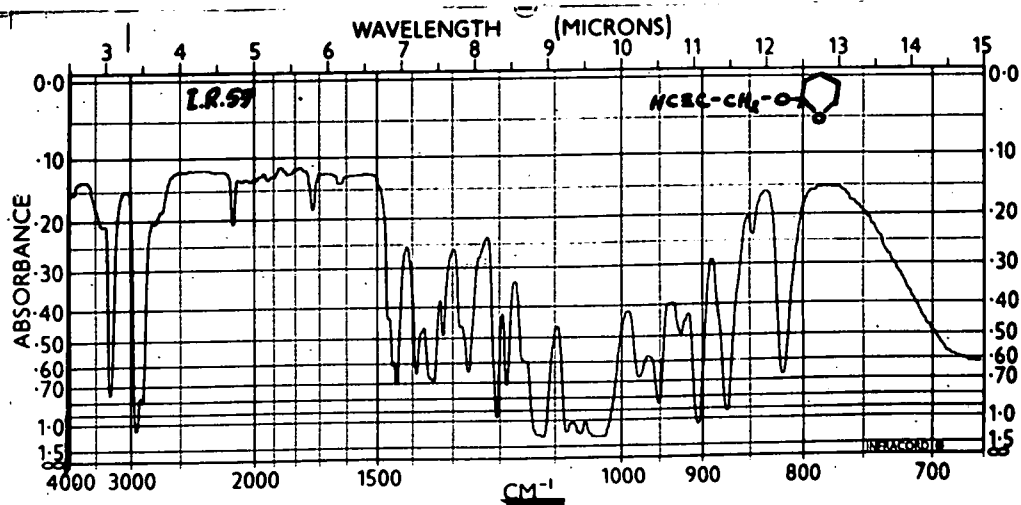
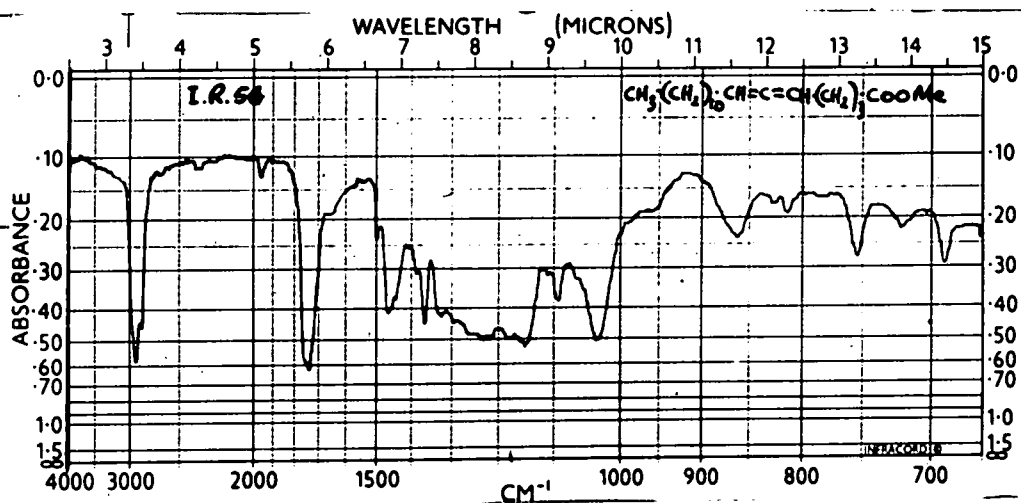
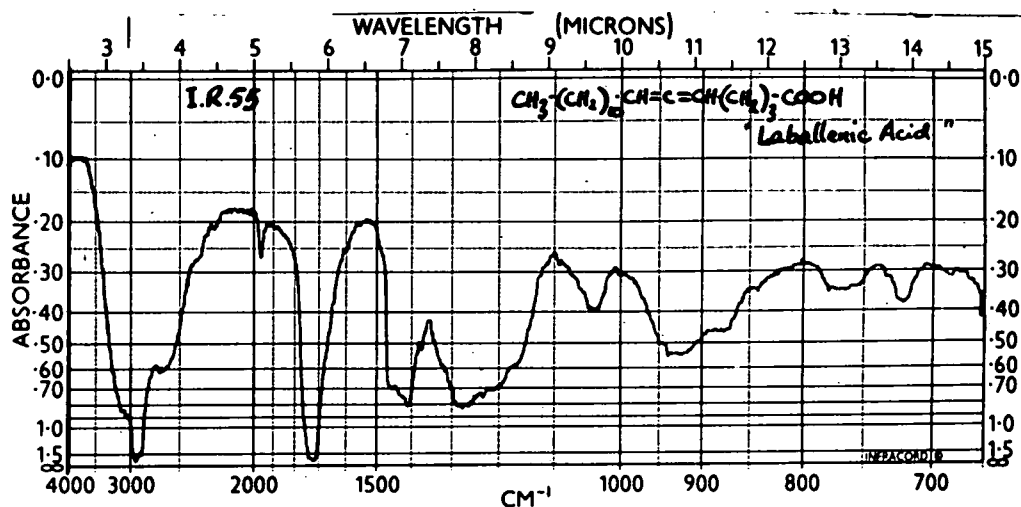

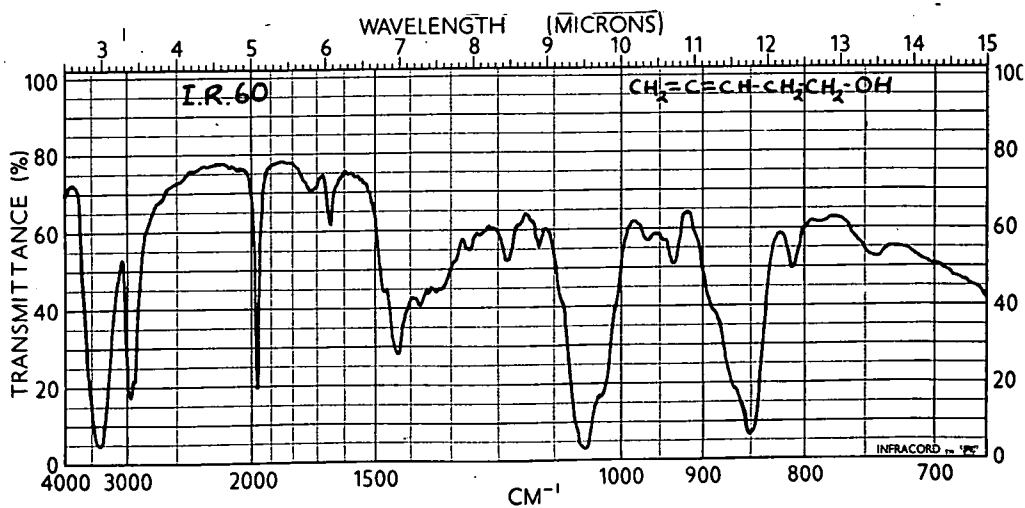
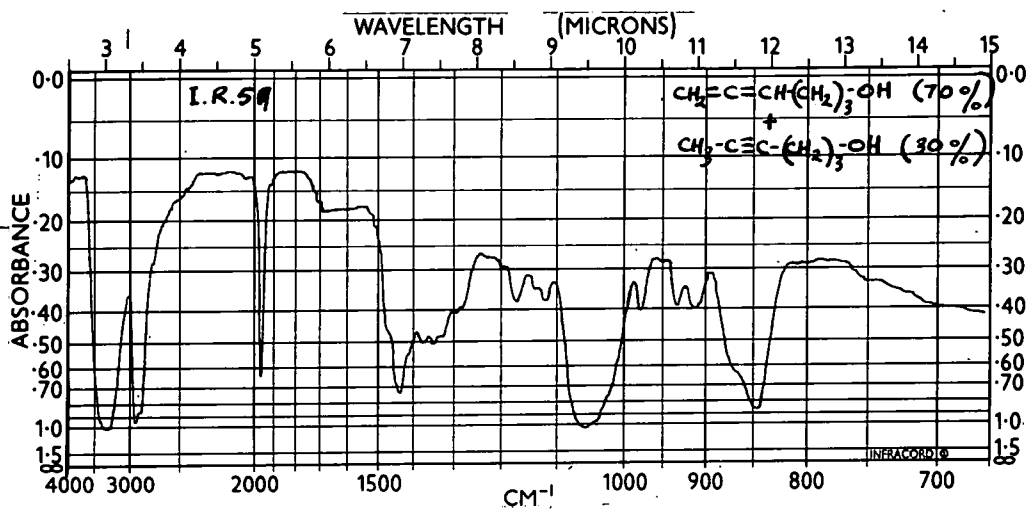
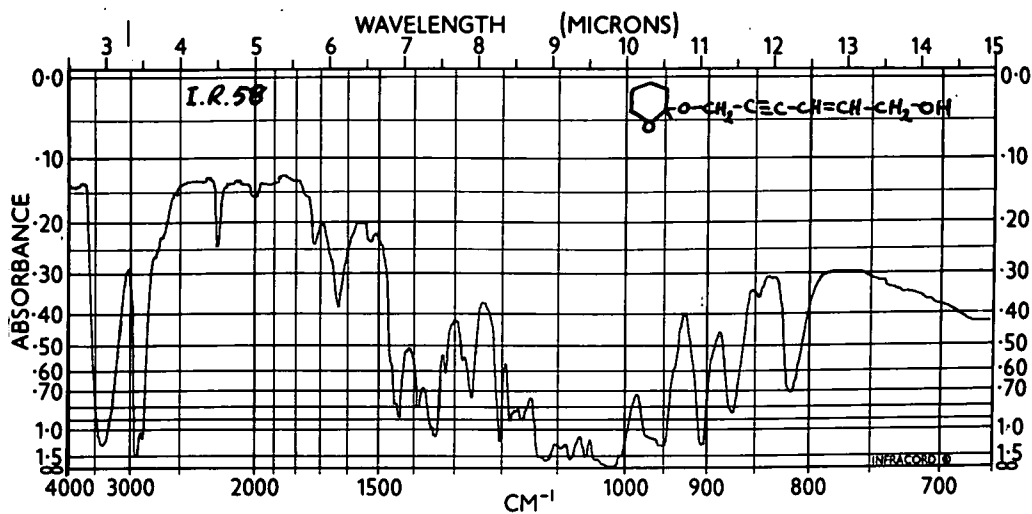

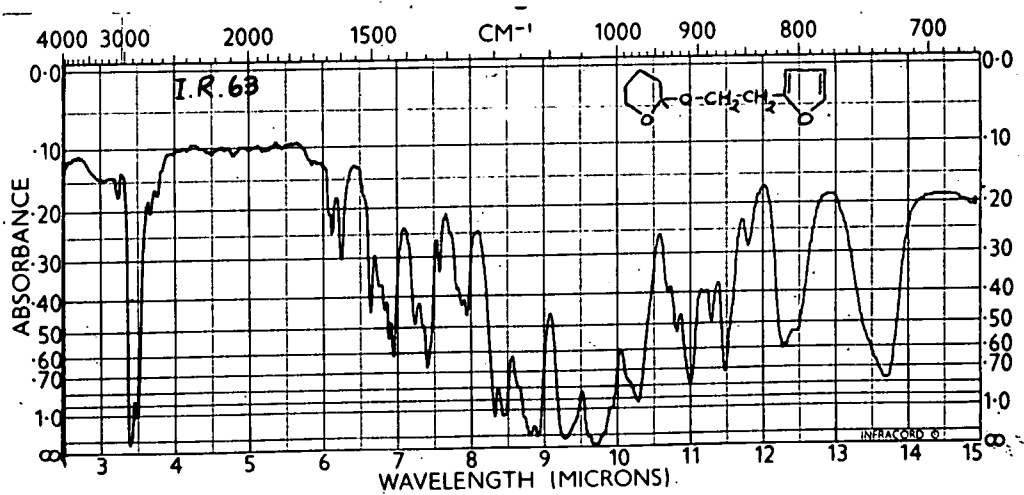
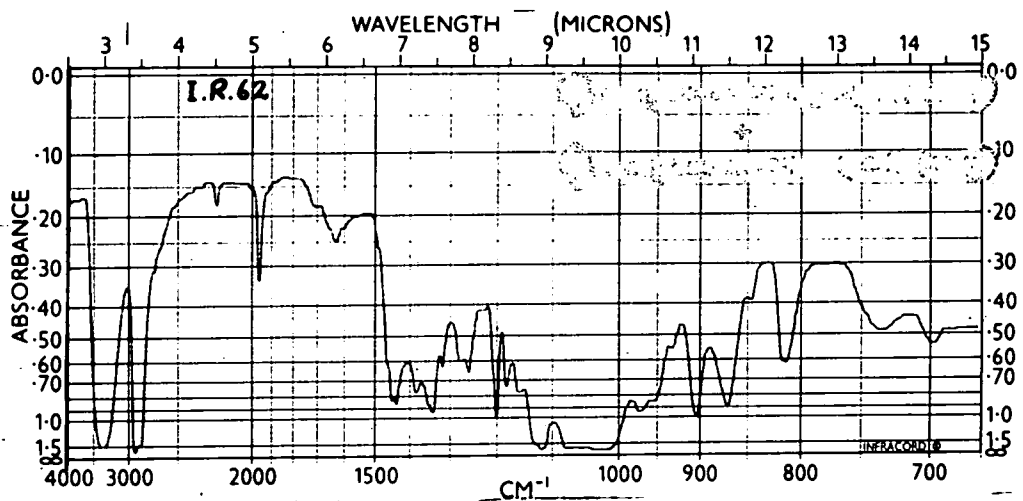
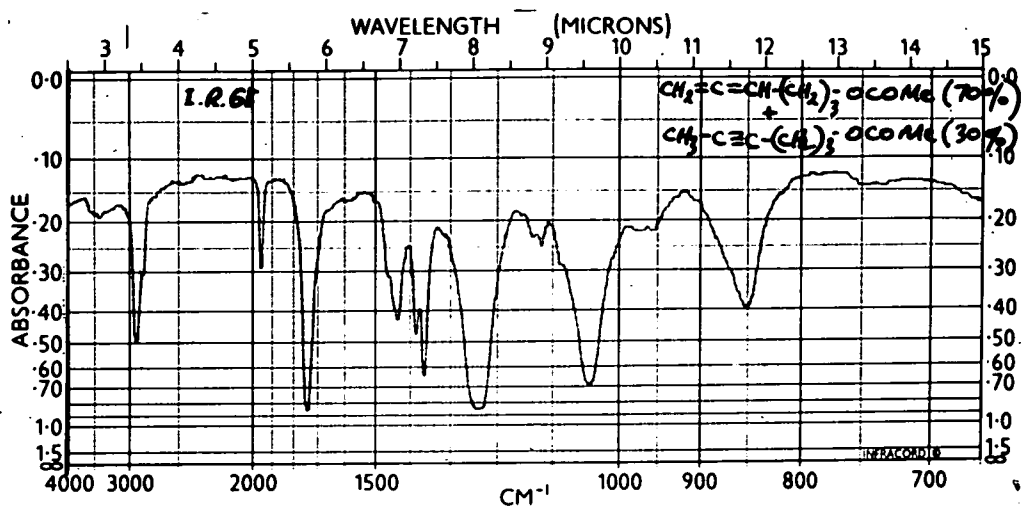

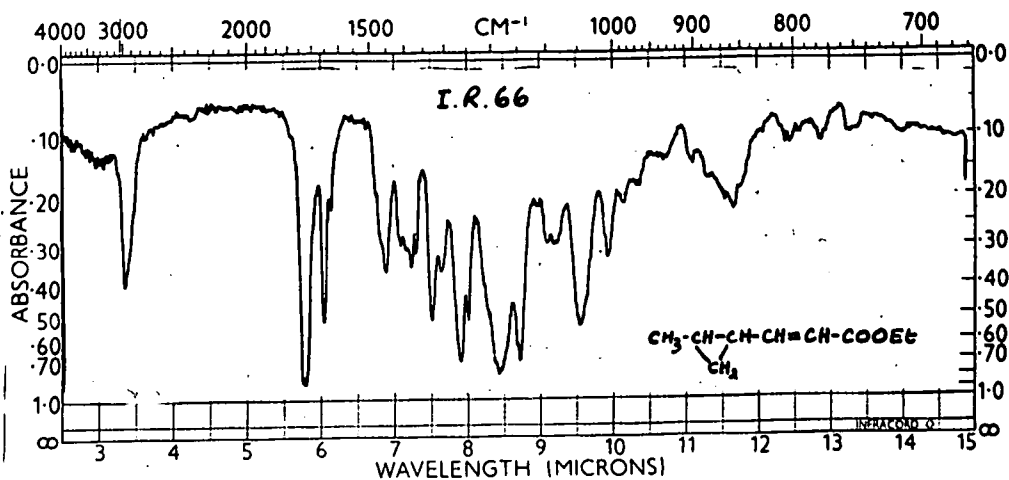
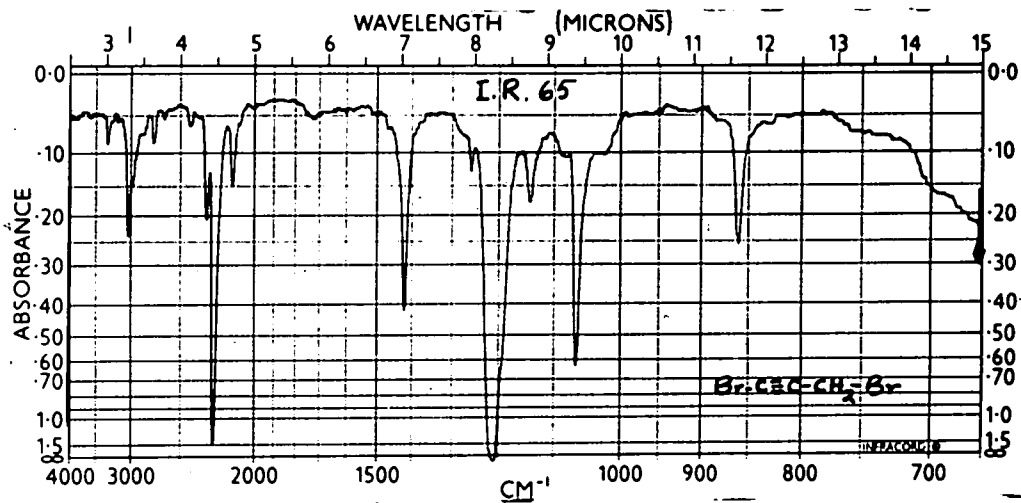
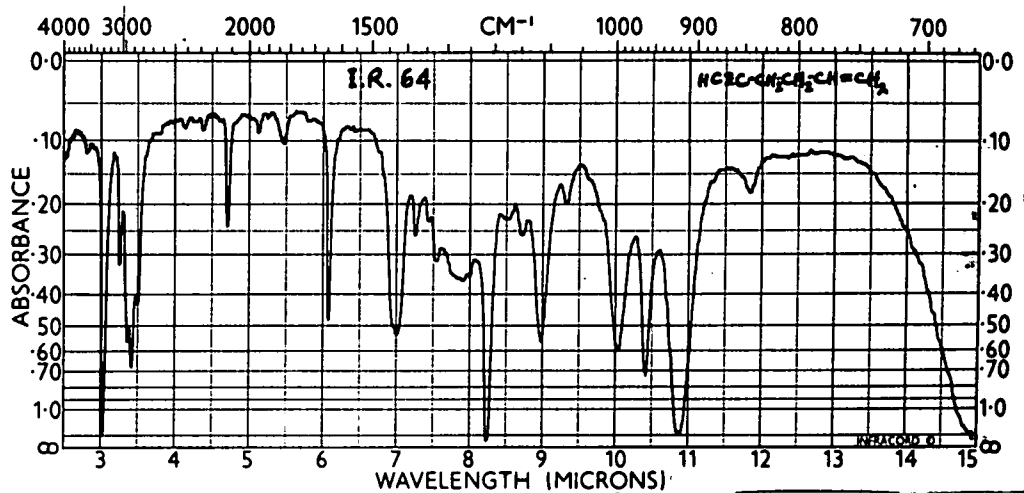

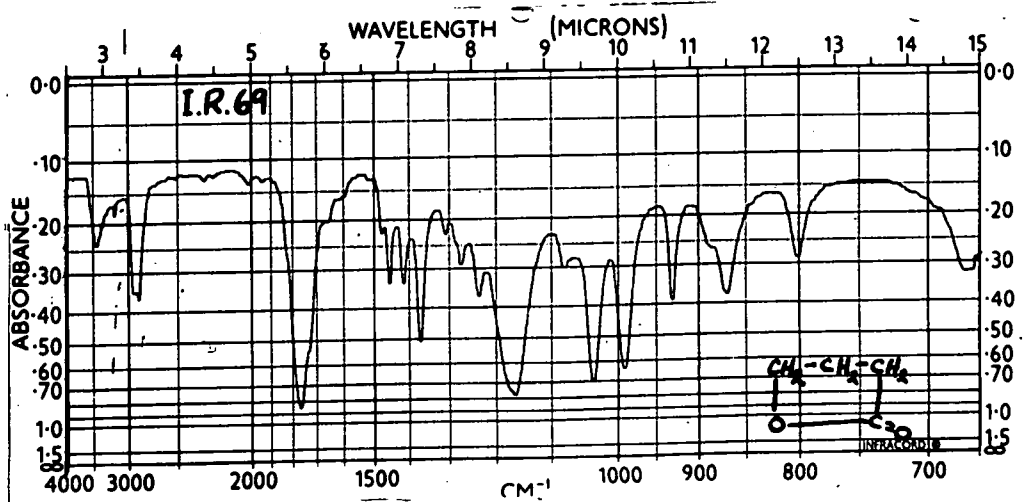
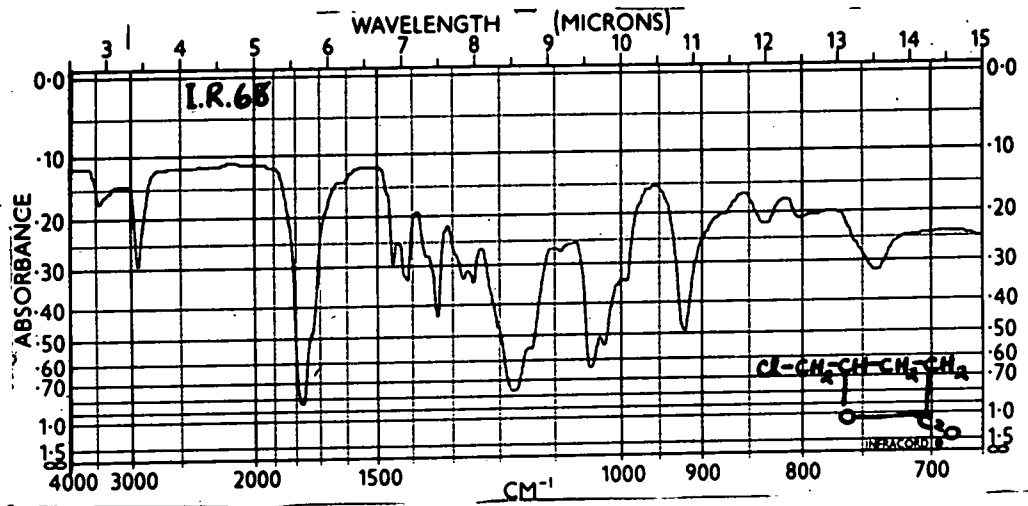
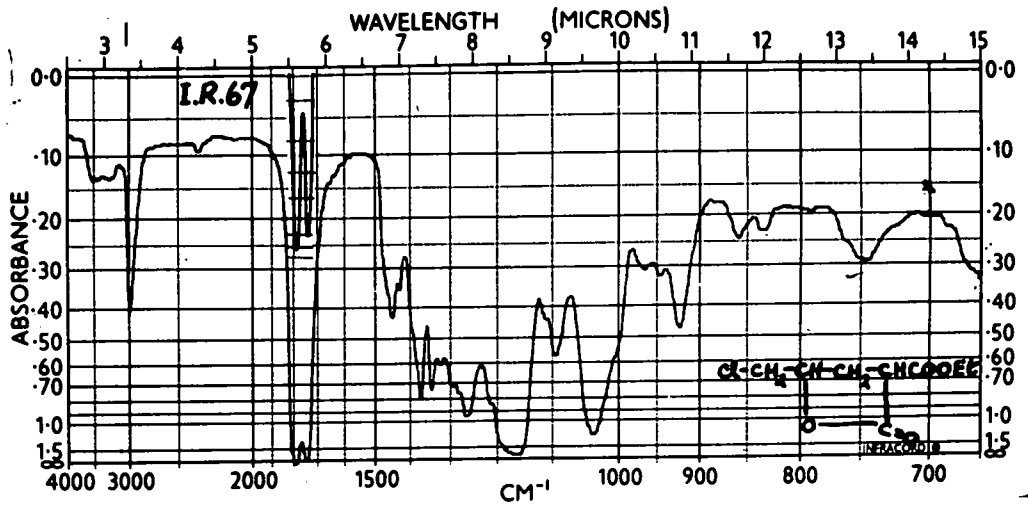

ULTRA-VIOLET SPECTRA

Ultra-violet Spectra

<u>No.</u>	<u>Index</u>	<u>Page</u>
1,	1,1-Dichloro-2-methyl-2-ethyl-3-methylene-cyclopropane	236
2	1,1-Dibromo-2,2-dimethyl-3-methylenecyclopropane	236
3	4-Ethyl-hexa-1,2,3-triene	236
4	Comparison of ethyl <u>trans</u> -crotonate and ethyl <u>trans</u> -2-methylcyclopropane-1-carboxylate	236
5	Comparison of ethyl <u>trans</u> -cinnamate and ethyl <u>trans</u> -2-phenylcyclopropane-1-carboxylate	237
6	Comparison of ethyl <u>trans-trans</u> -penta-2,4-dienoate and ethyl 2-vinylcyclopropane-1-carboxylate	237
7	Comparison of ethyl <u>trans-trans</u> -sorbate, ethyl 2,3-methylene-hex-4-enoate and ethyl 4,5-methylene-hex-2-enoate	237
8	Comparison of Diethyl benzylidenemalonate and diethyl 2-phenylcyclopropane-1,1-dicarboxylate	237
9	Comparison of mesityl oxide and 2,2-dimethylcyclopropane-methyl-ketone	238
10	Comparison of ethyl buta-2,3-dienoate and Dimethylsulphoxonium 3-ethoxycarbonyl-2-methylallylide	238
11	Comparison of 1-Tetrahydropyranyloxy-pent-2-en-4-yne, hexadec-2-en-4-yn-1-ol and 1-Tetrahydropyranyloxy-hex-2-yn-4-en-6-ol	238
12	1-Tetrahydro-2-furylethane	238

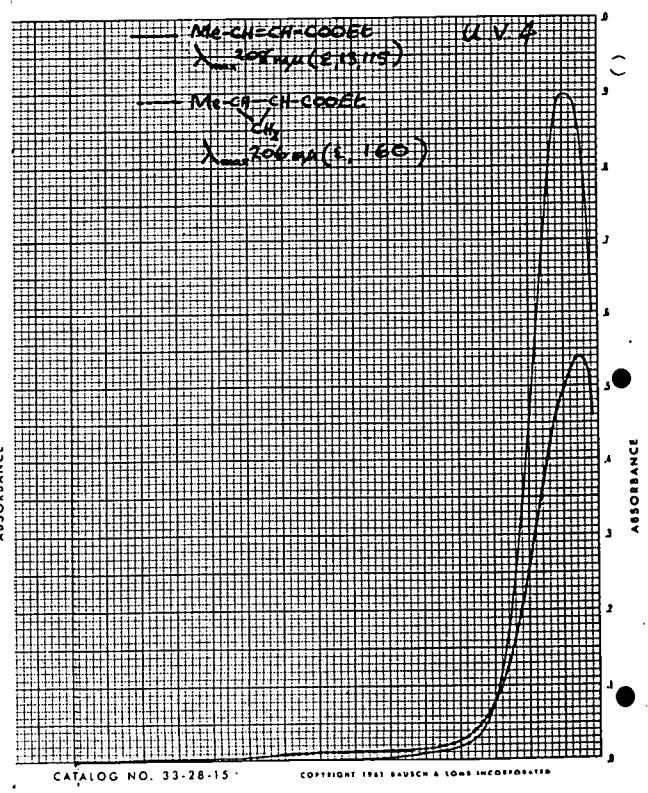
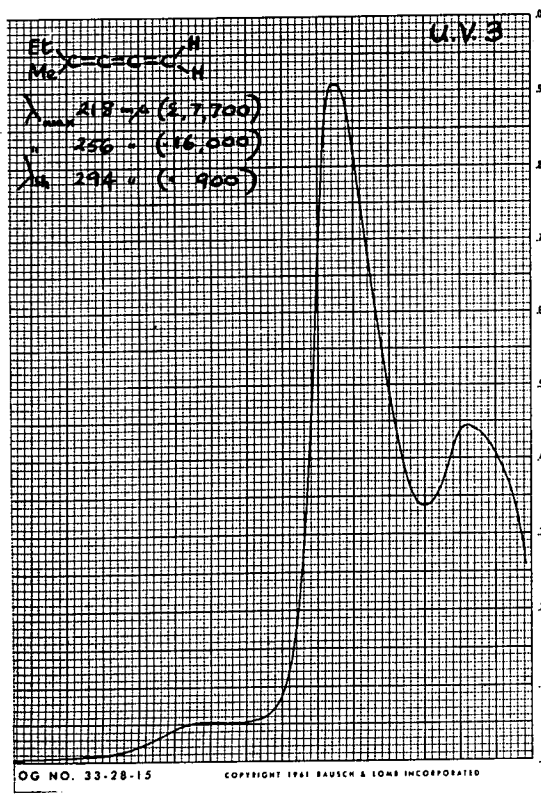
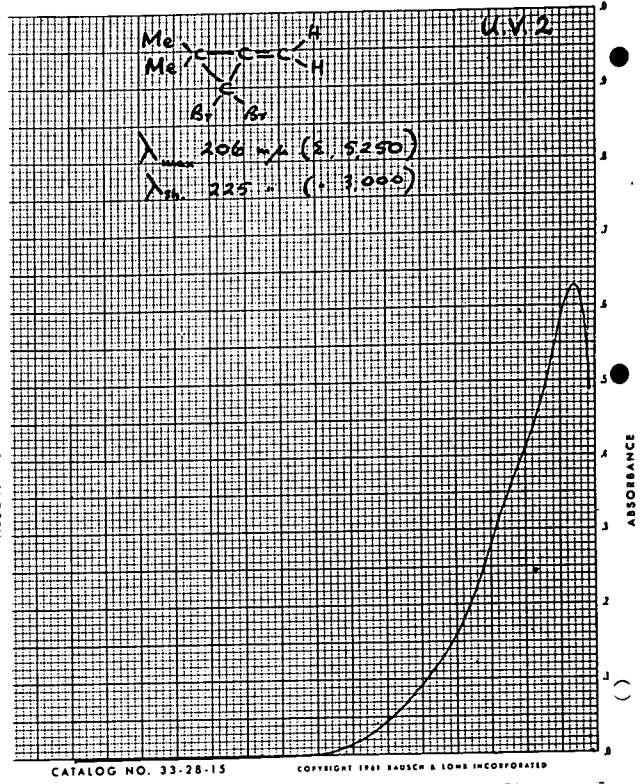
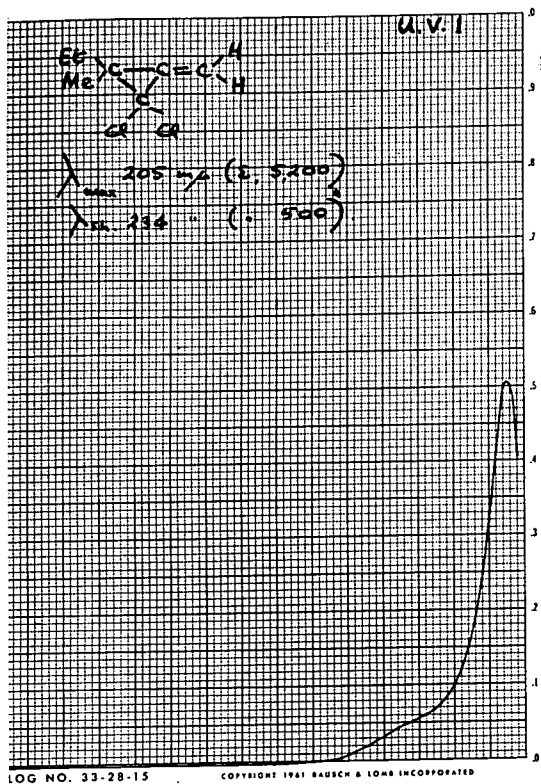

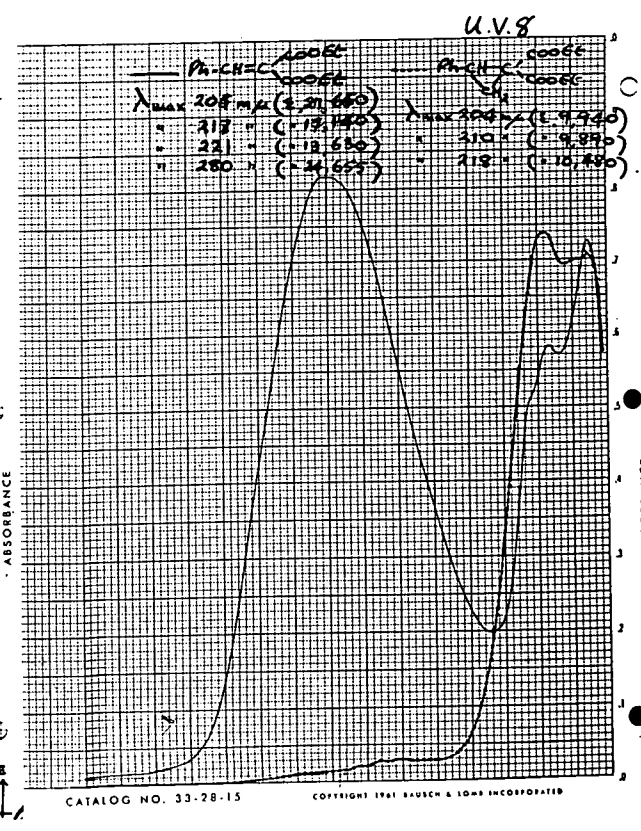
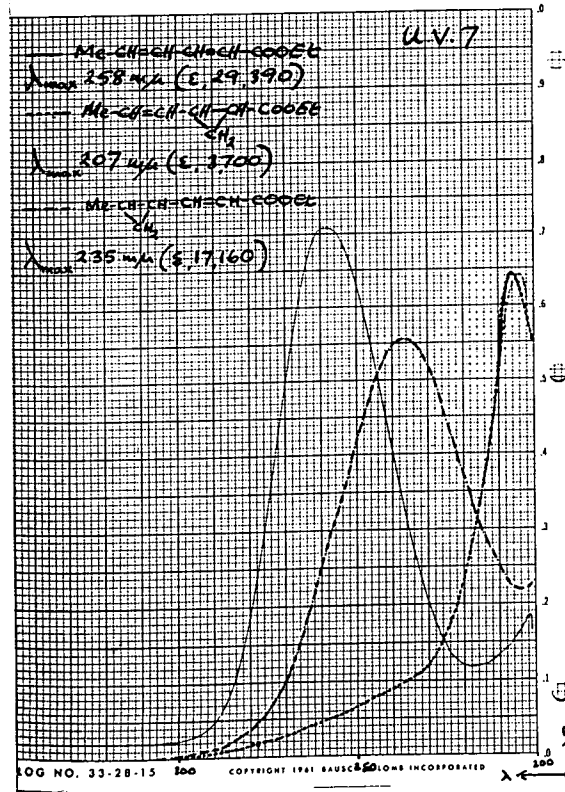
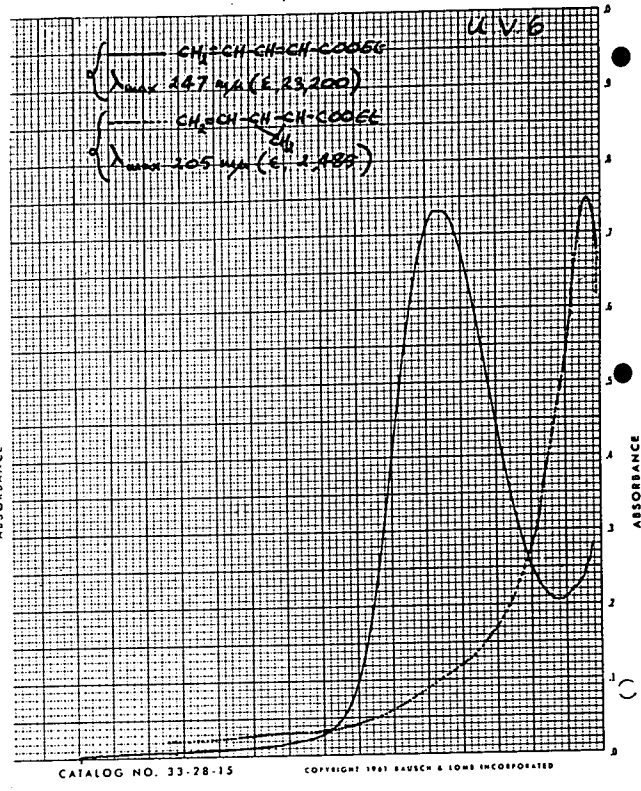
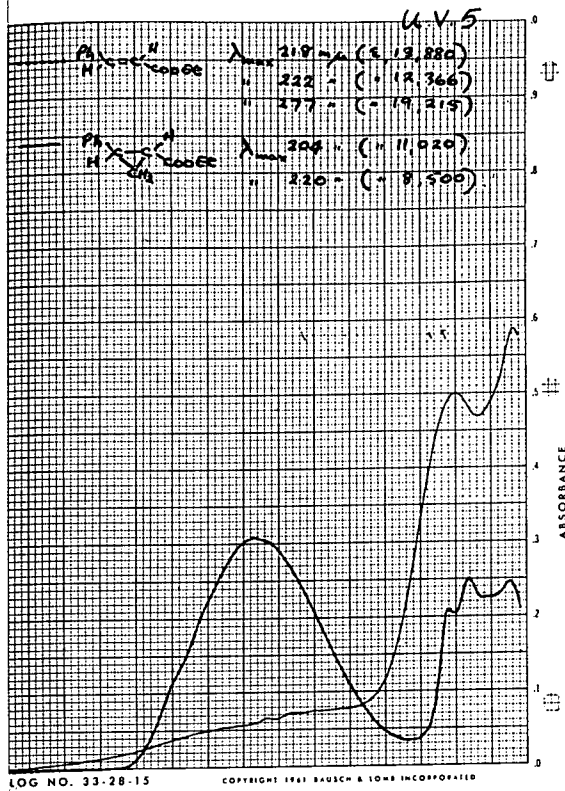

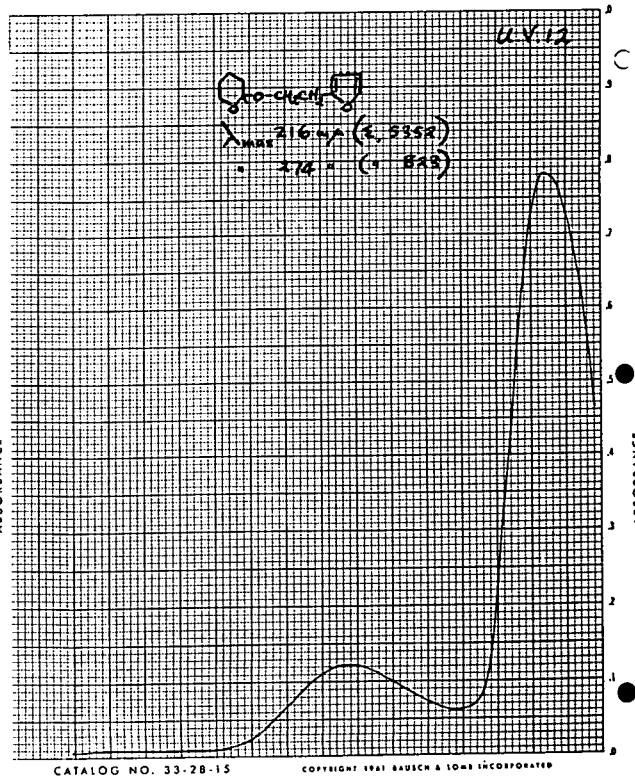
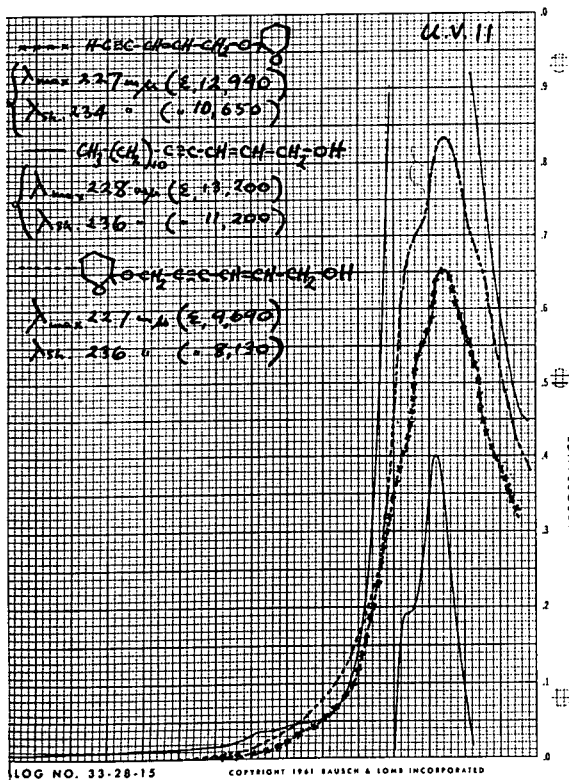
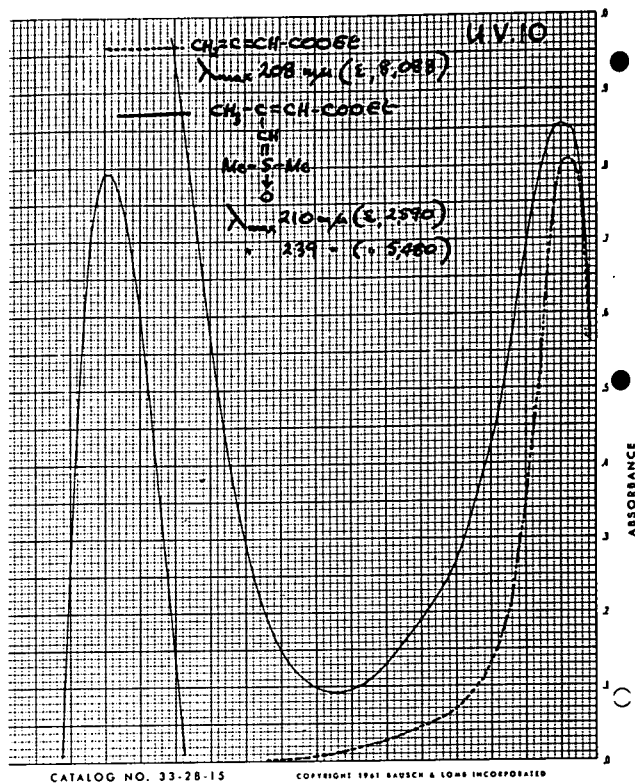
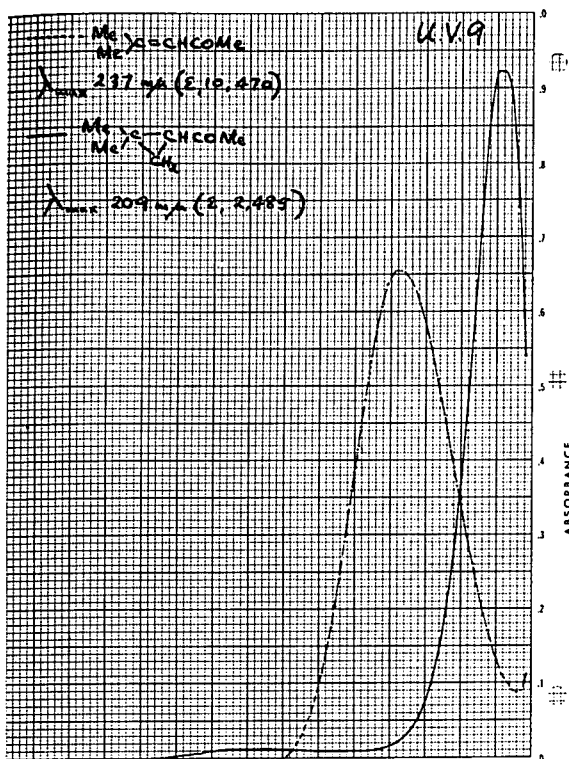

NUCLEAR MAGNETIC RESONANCE SPECTRA

Nuclear magnetic resonance spectra:

<u>No.</u>	<u>Index</u>	<u>Page</u>
1	1,1-Dichloro-2,2-dimethyl-3-methylenecyclopropane	242
2	1,1-Dichloro-2-methyl-2-ethyl-3-methylenecyclopropane	243
3	1,1-Dibromo-2,2-dimethyl-3-methylenecyclopropane	244
4	δ -Chloro- α -carbethoxy- γ -valerolactone	244
5	δ -Chloro- γ -valerolactone	245
6	γ -Butyrolactone	245
7	Ethyl buta-2,3-dienoate	246
8	Hexa-4,5-dien-1-ol and hex-4-yn-1-ol (70:30%)	246
9	1-Tetrahydropyranyloxy-hex-2-yn-4-en-6-ol	247
10	1,3-Dibromo-prop-1-yne	247
11	Ethyl <u>trans</u> -crotonate	248
12	Ethyl <u>trans</u> -2-methylcyclopropane-1-carboxylate	248
13	Diethyl 2-methylcyclopropane-1,1-dicarboxylate	248
14	Diethyl n-propylidenemalonate	249
15	Diethyl 2-ethylcyclopropane-1,1-dicarboxylate	249
16	Diethyl isopropylidenemalonate	249
17	Diethyl 2,2-dimethylcyclopropane-1,1-dicarboxylate	250
18	Diethyl n-butylidenemalonate	250
19	Diethyl iso-butylidenemalonate	250

<u>No.</u>	<u>Index</u>	<u>Page</u>
20	Diethyl 2-iso-propylcyclopropane-1,1-dicarboxylate	251
21	Diethyl benzylidenemalonate	251
22	Diethyl 2-phenylcyclopropane-1,1-dicarboxylate	251

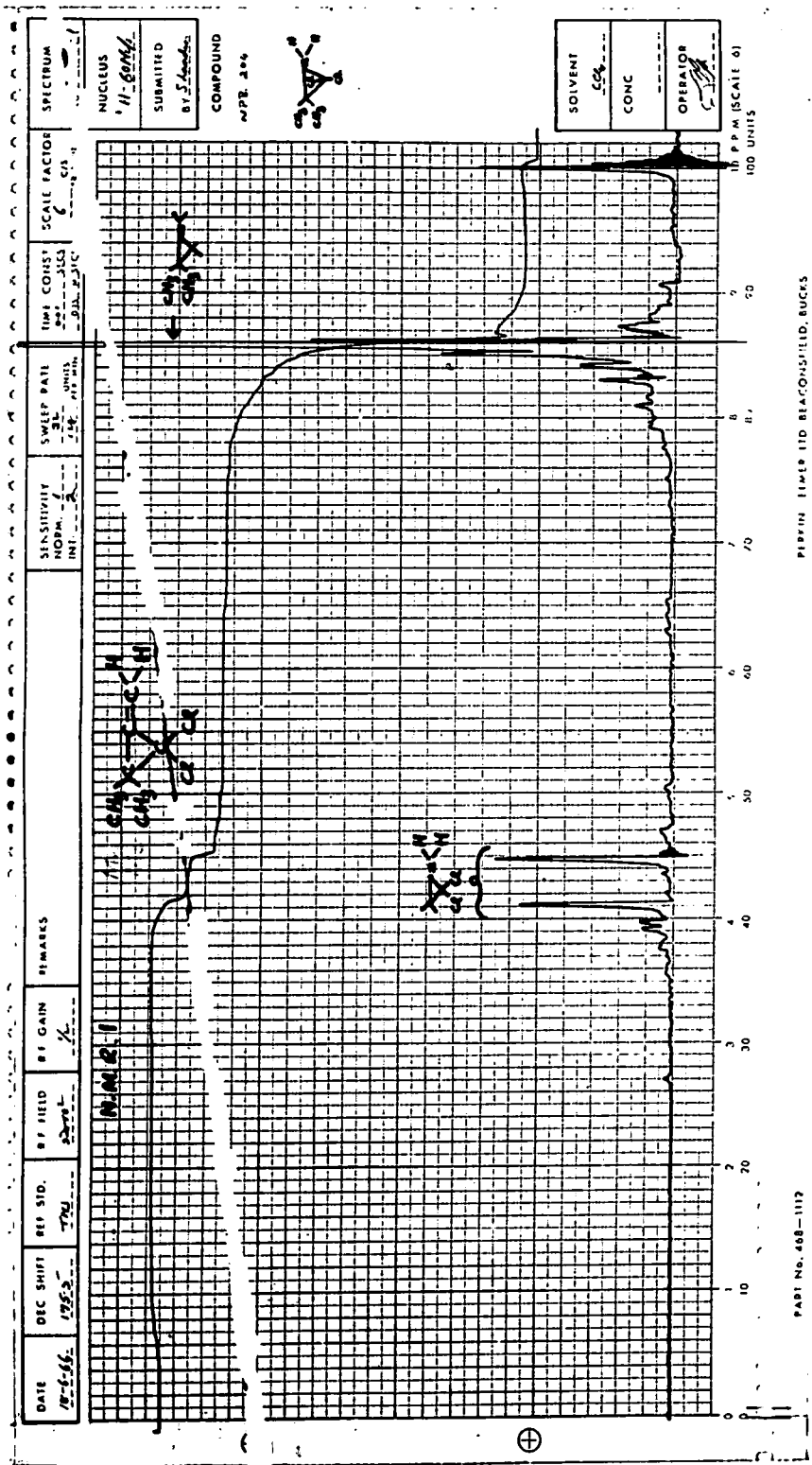

PERKIN ELMER LTD. BRACONSHIELD, RUCKS

PART NO. 468-1117

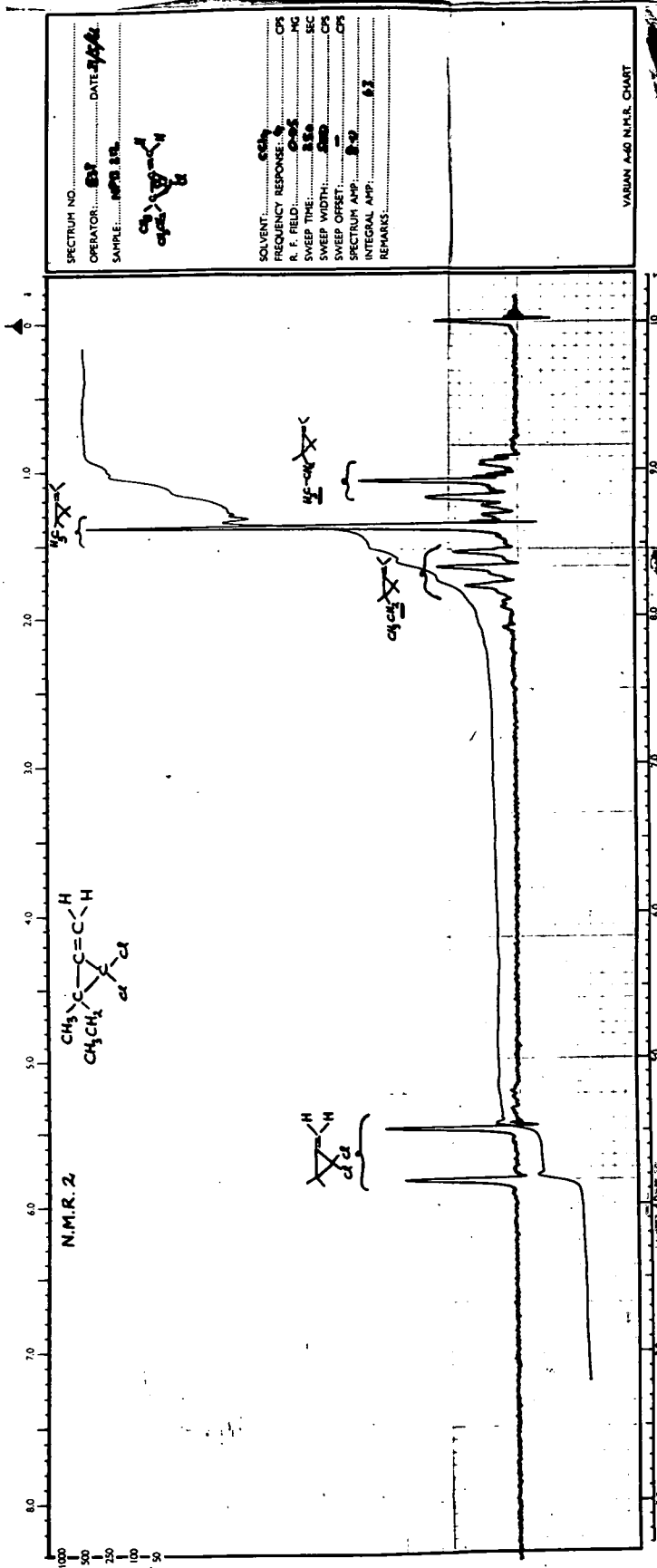

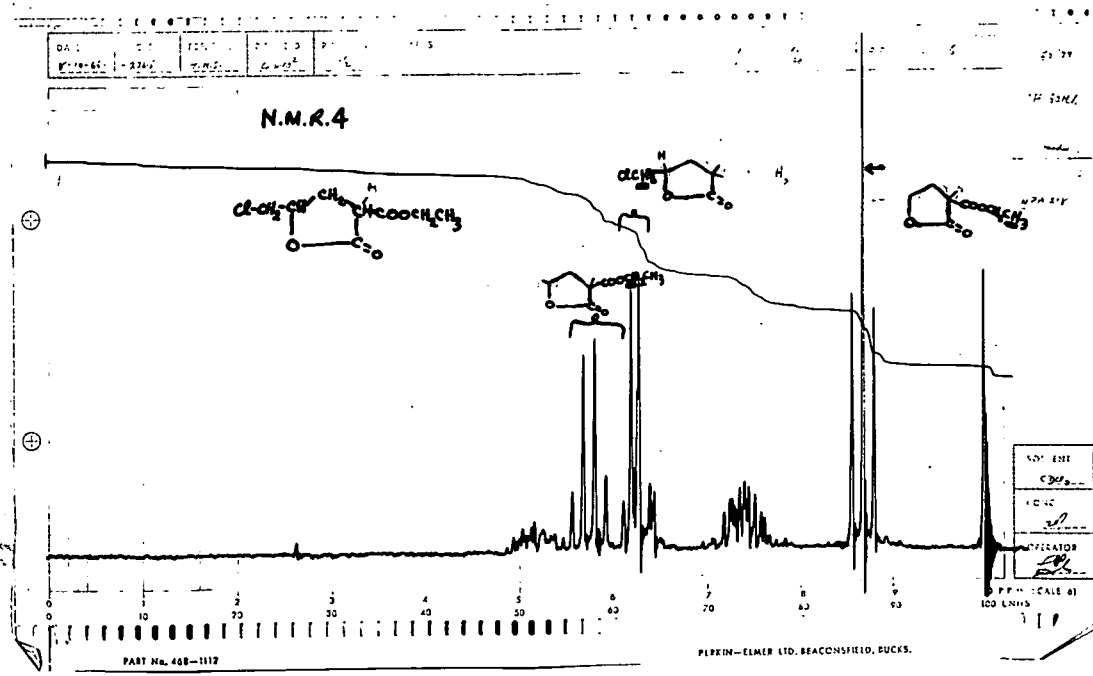
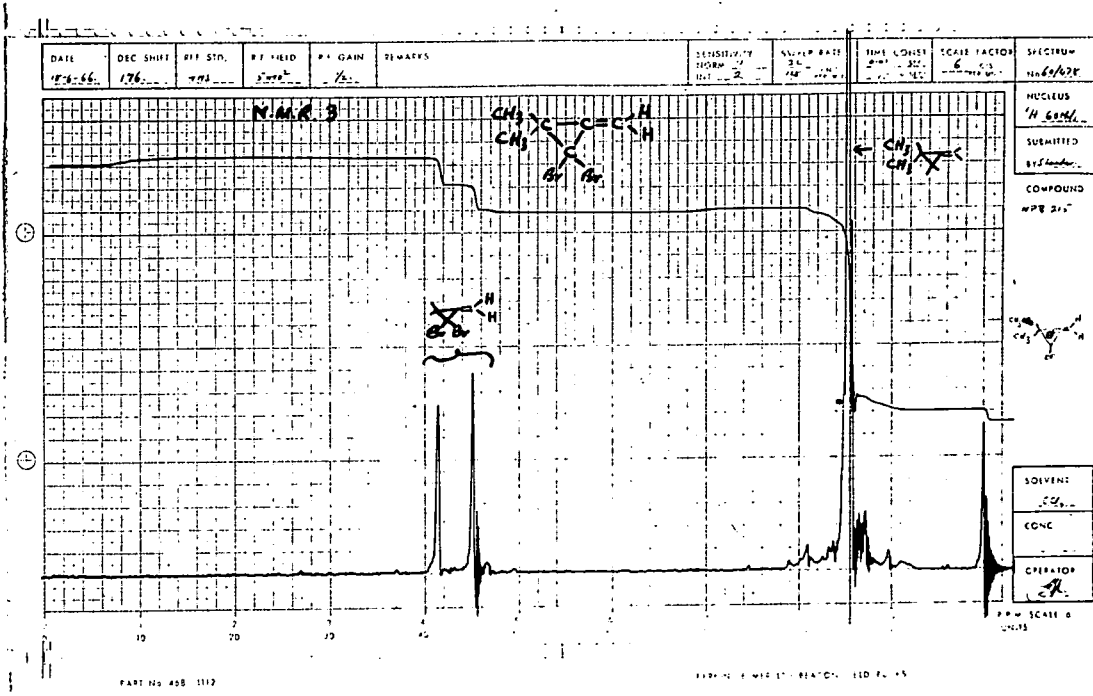

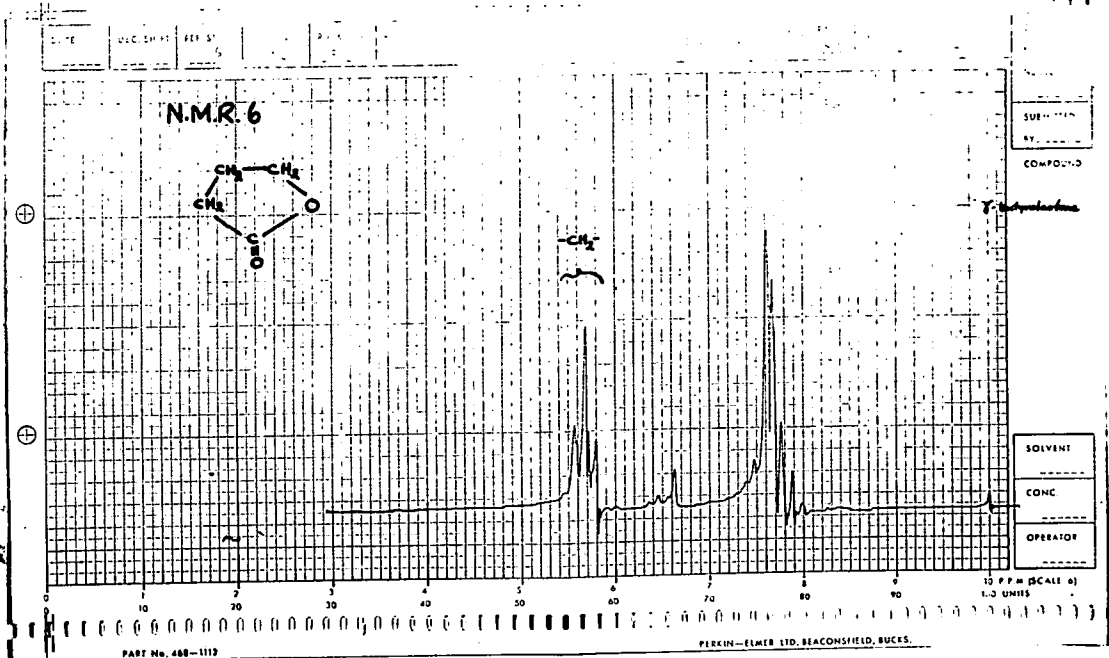
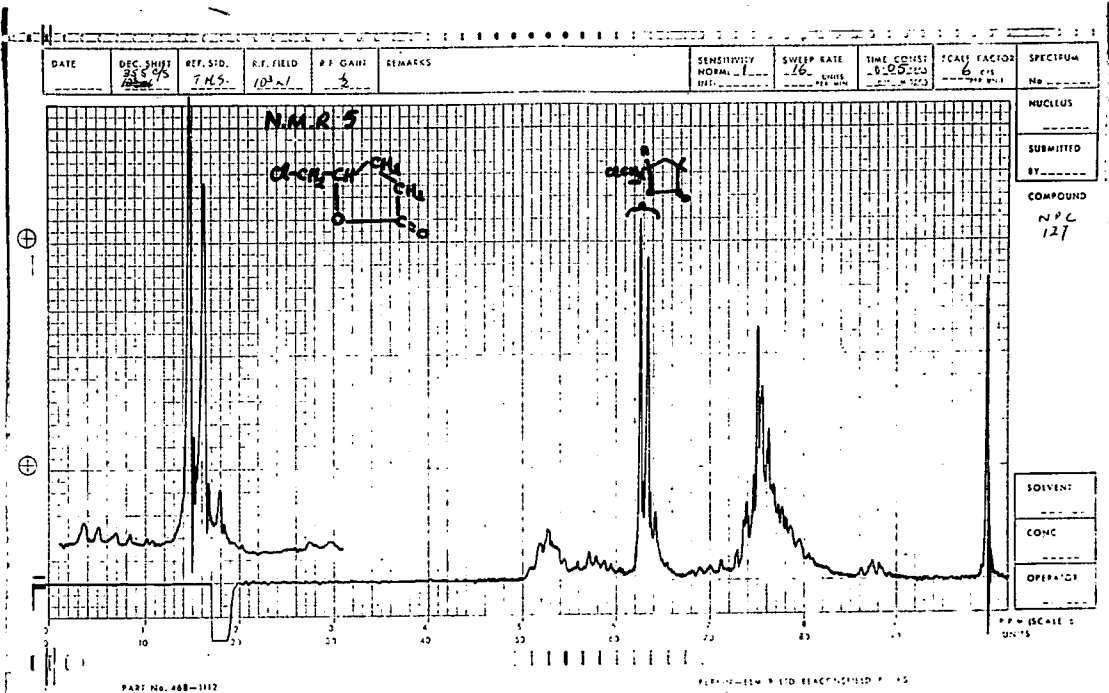

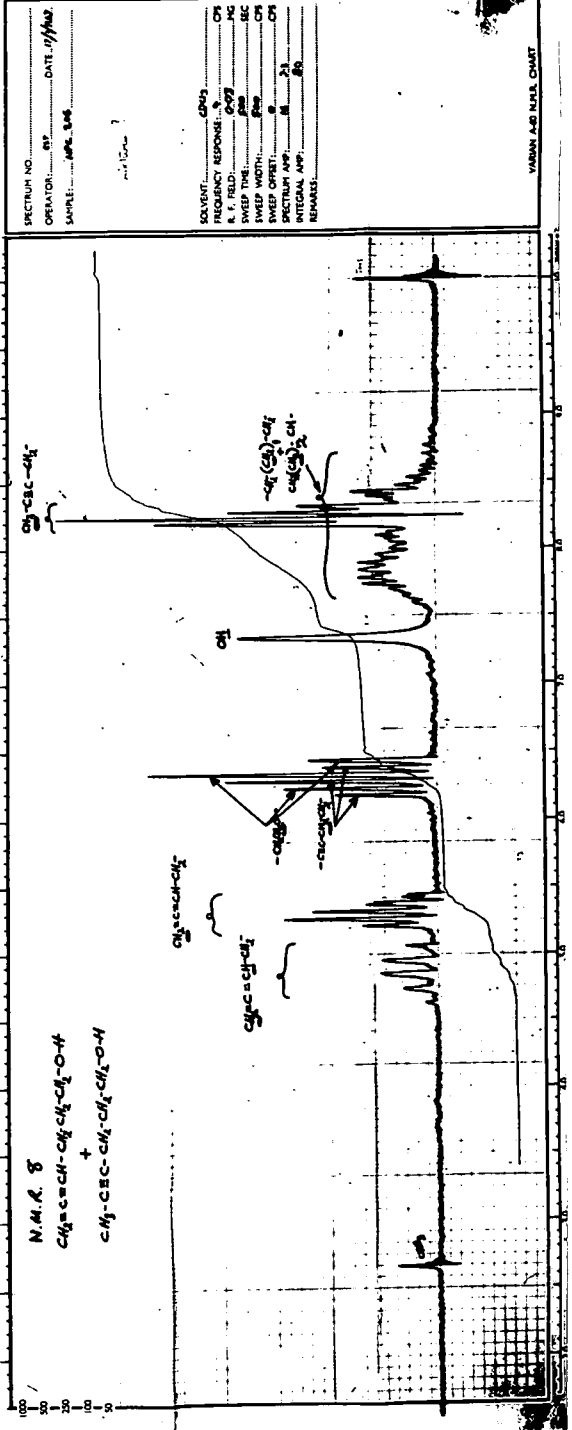
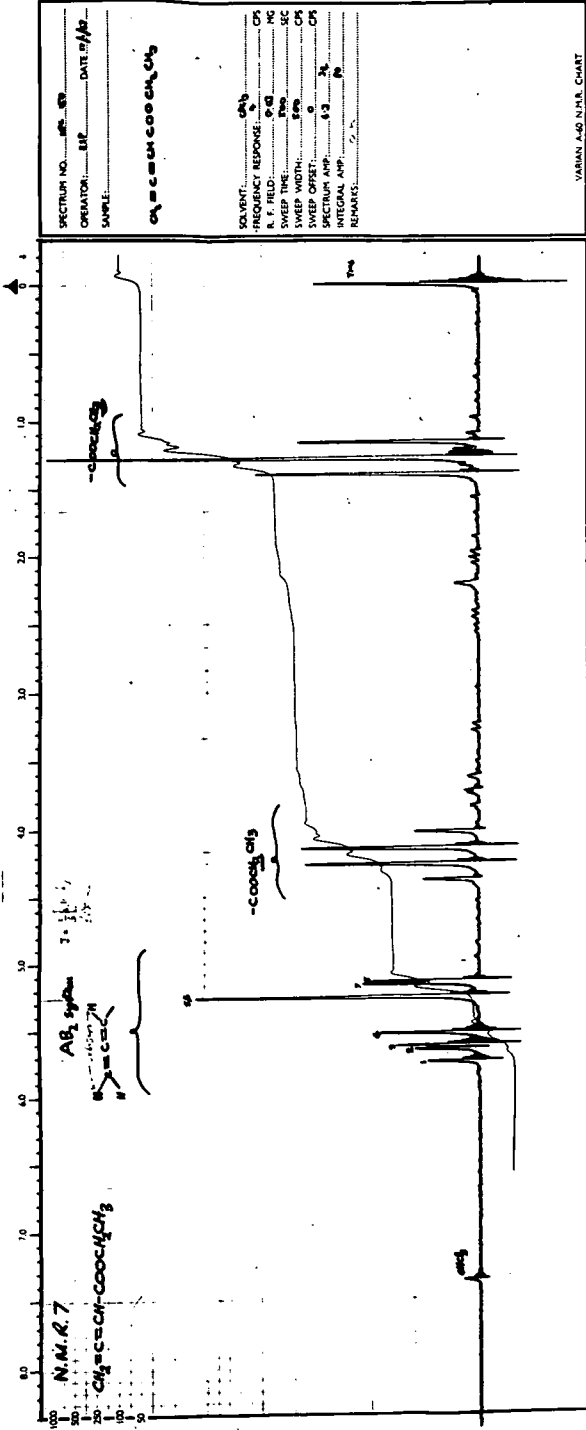

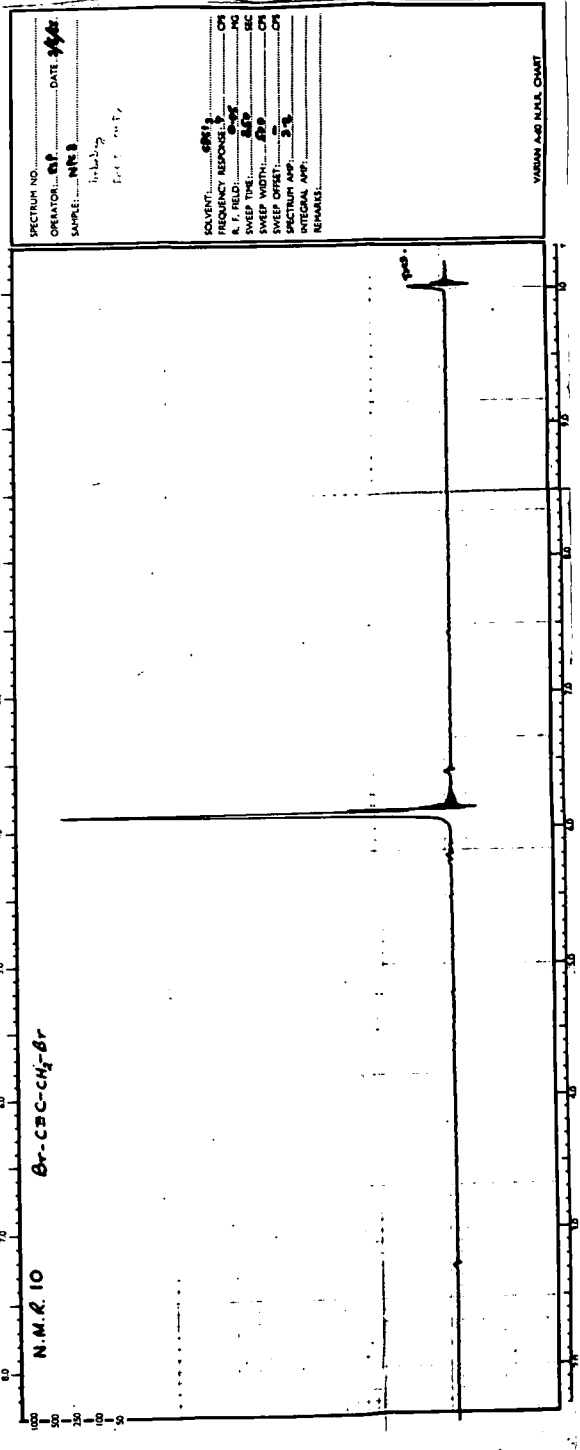
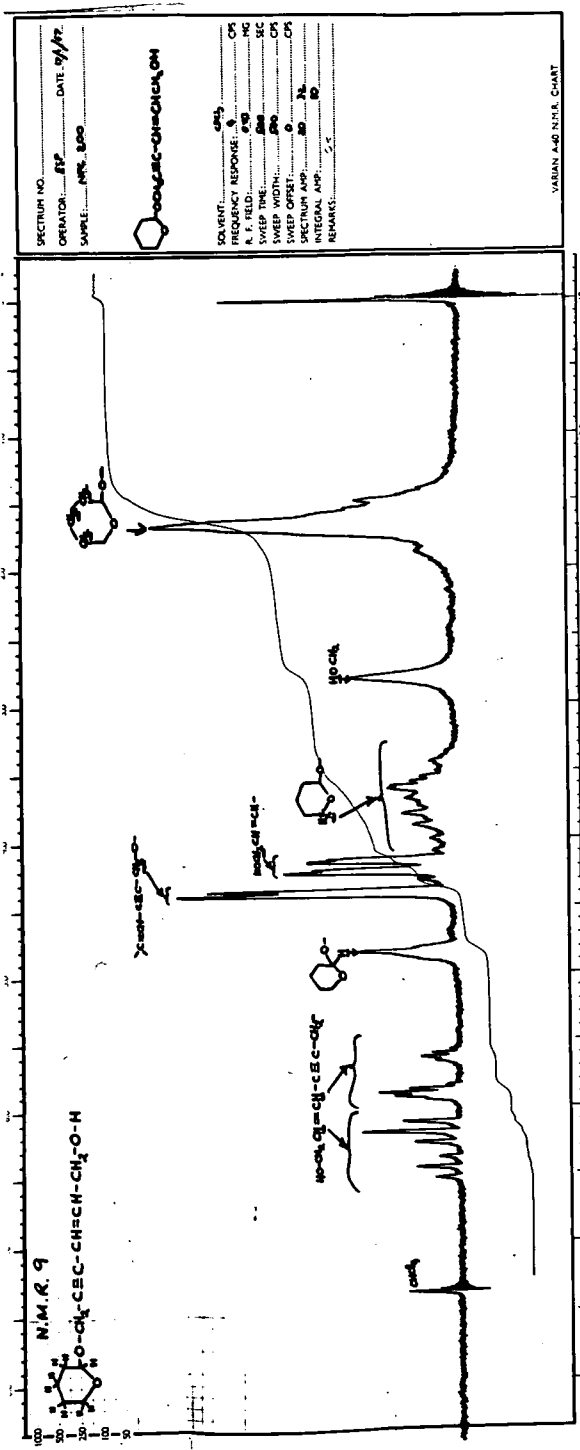

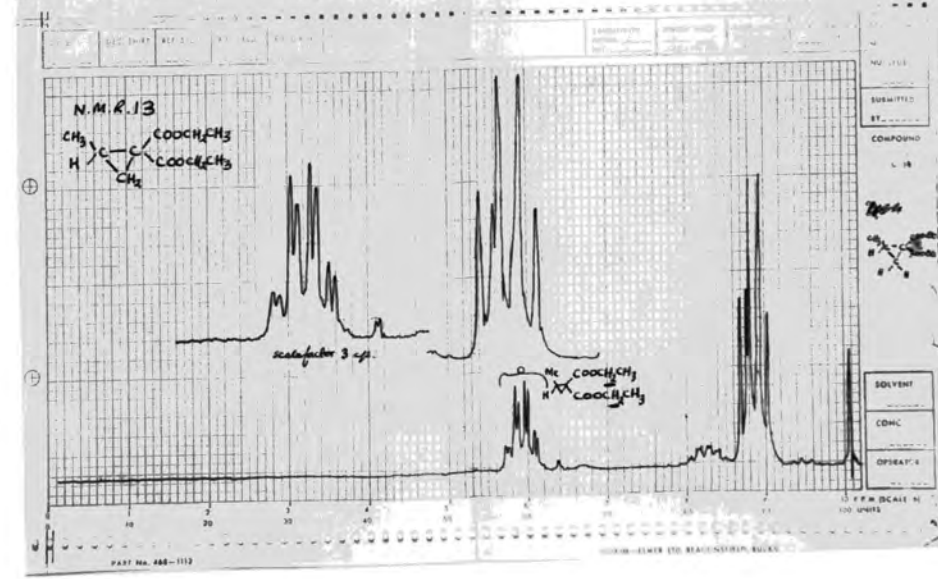
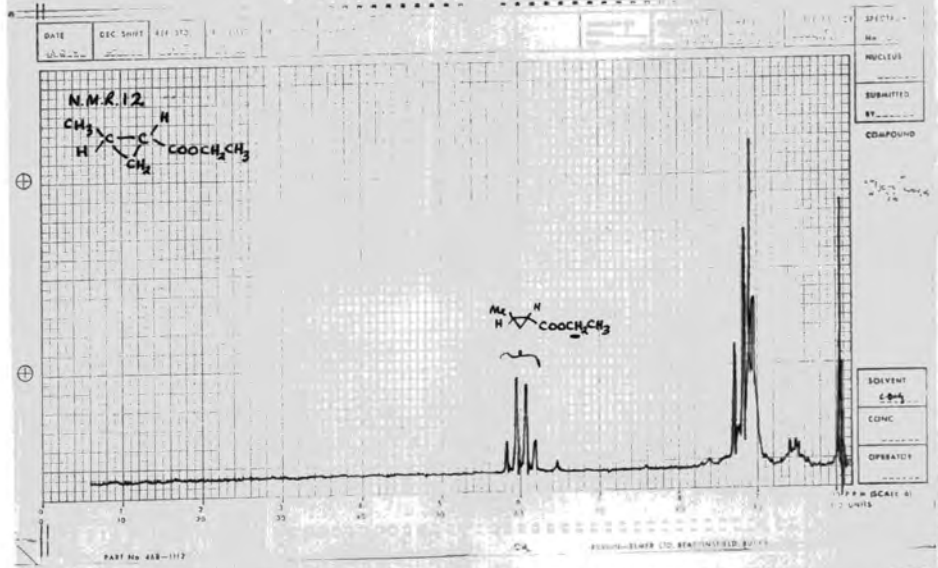
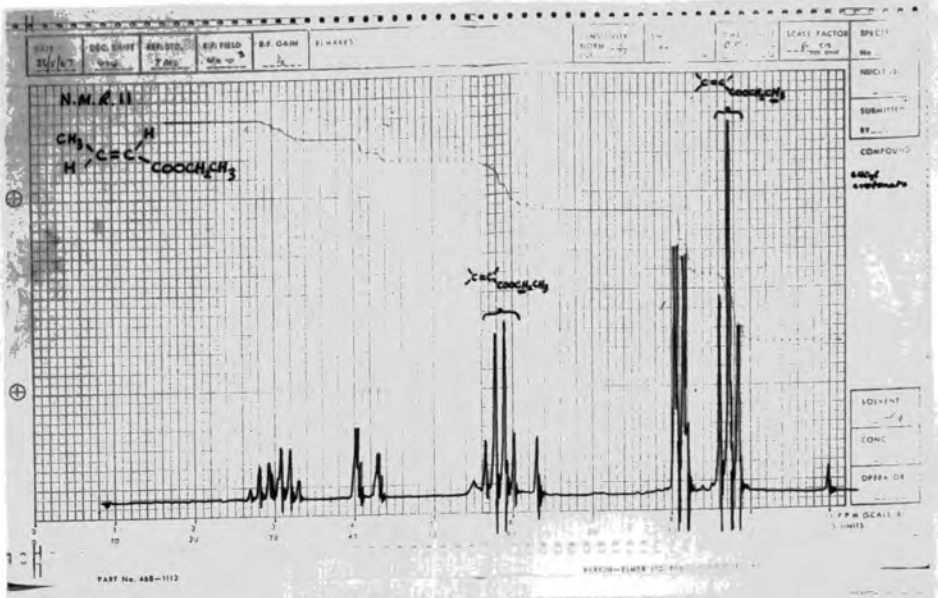

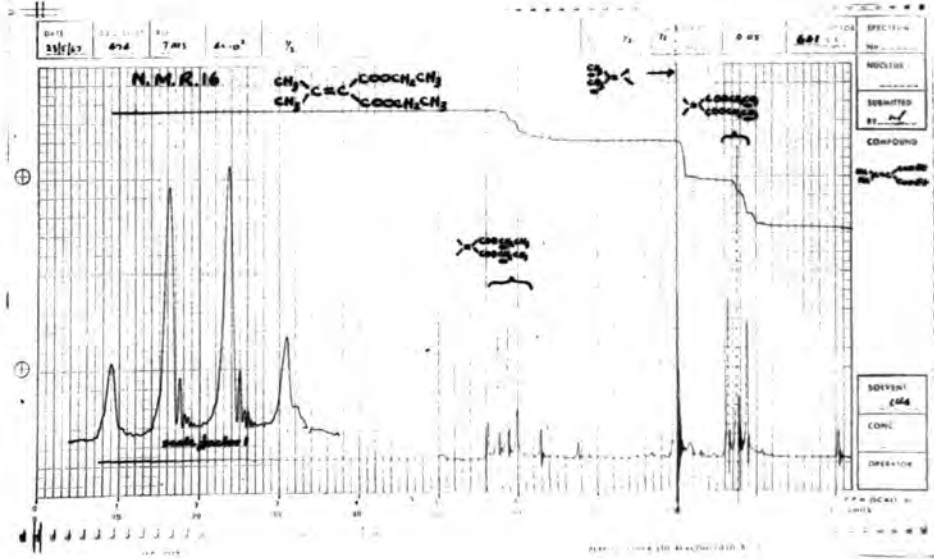
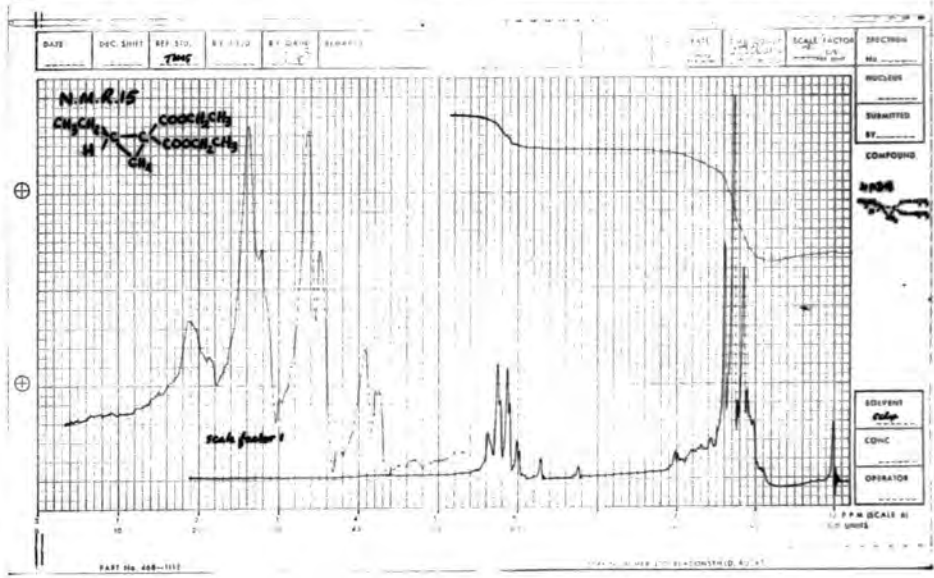

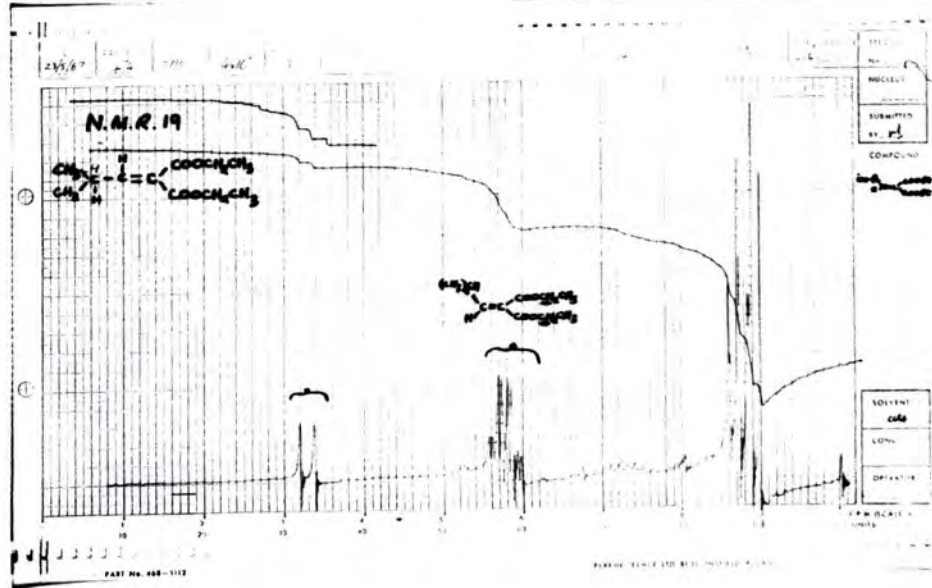
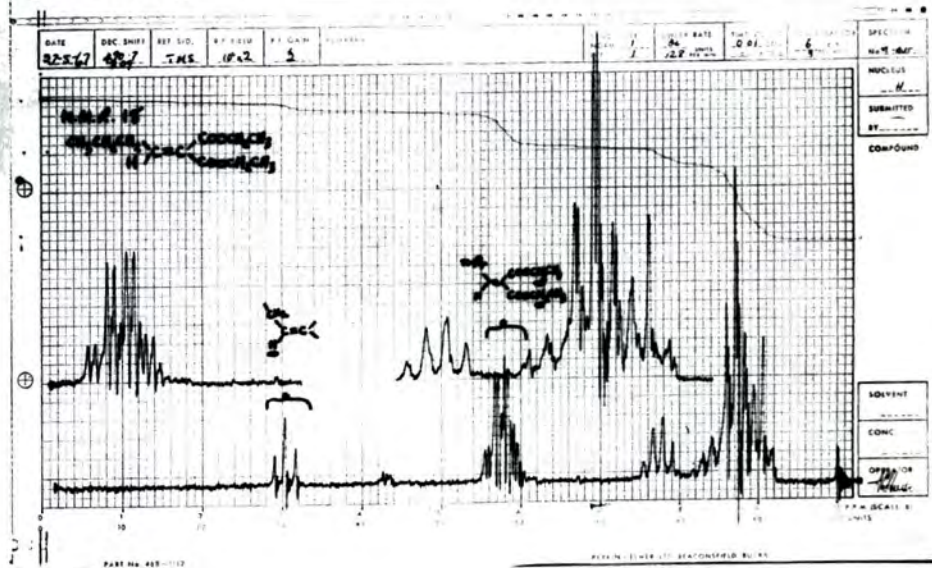
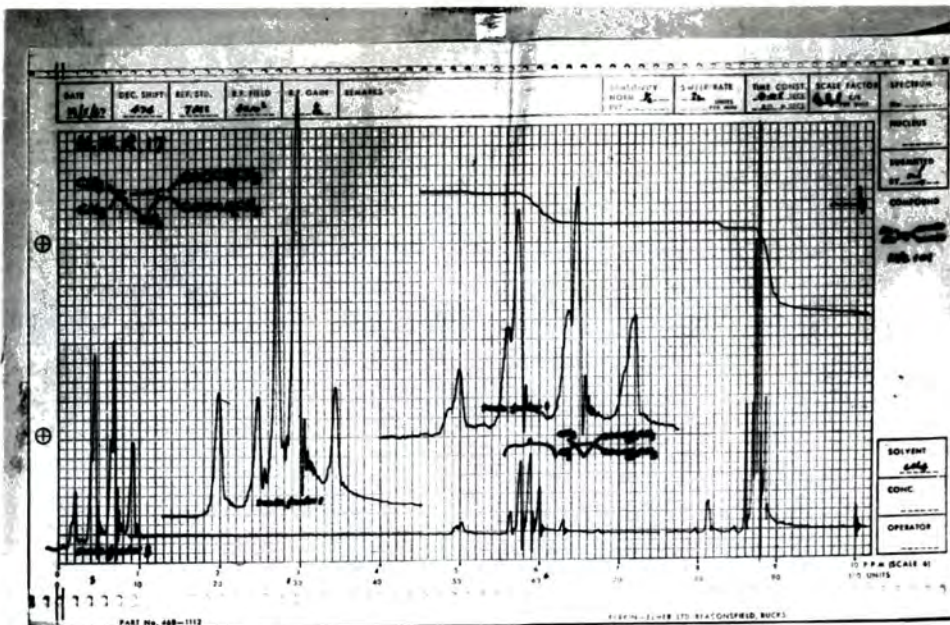

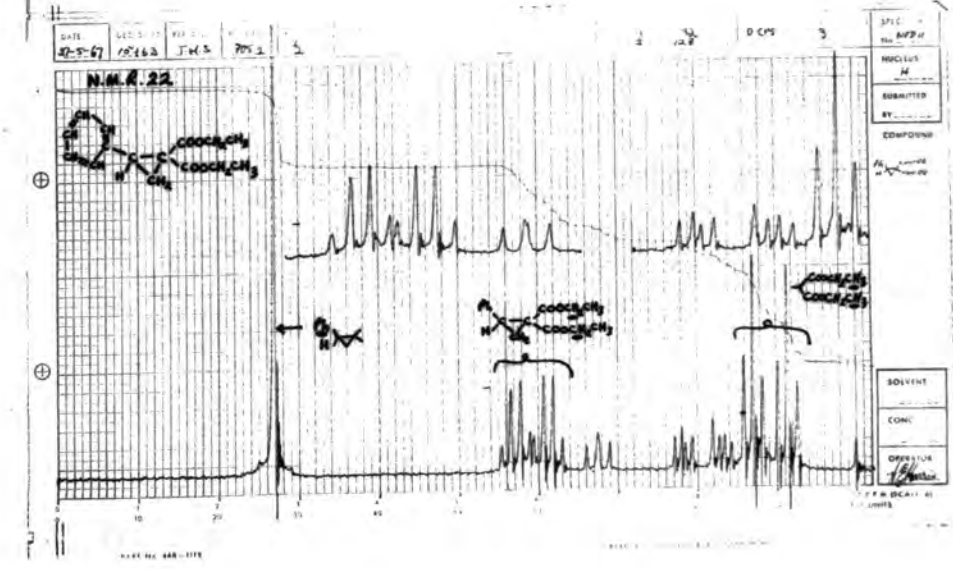
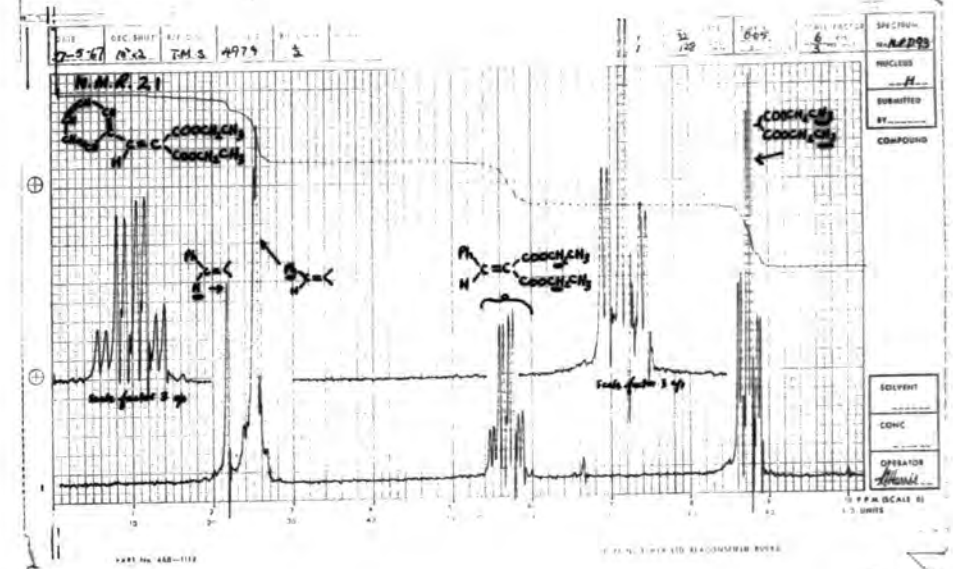
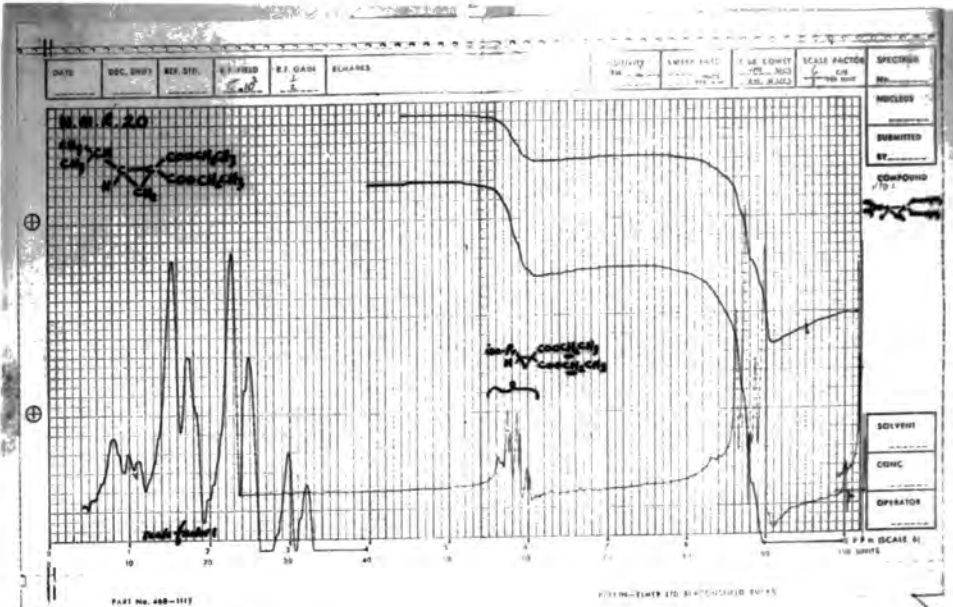

GAS LIQUID CHROMATOGRAPHS

Gas liquid chromatographs:

<u>No.</u>	<u>Index</u>	<u>Page</u>
1	Resolved and unresolved components for the mixture of hexa-4,5-dien-1-ol and hex-4-yn-1-ol (70:30%)	253
2	Resolved and unresolved components for the mixture of hexa-4,5-dienyl acetate and hex-4-ynyl acetate	253

E LTD. EALING ROAD, ALPERTON, WEMBLEY, MIDDLESEX

CHART No 3735W-041B. -15 to +9

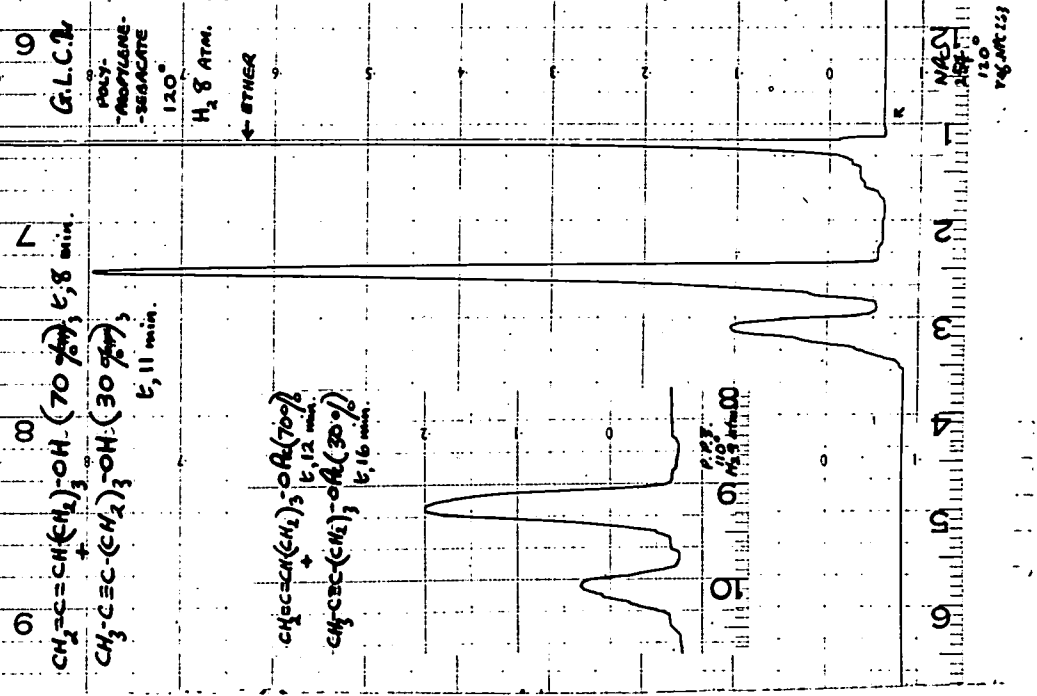
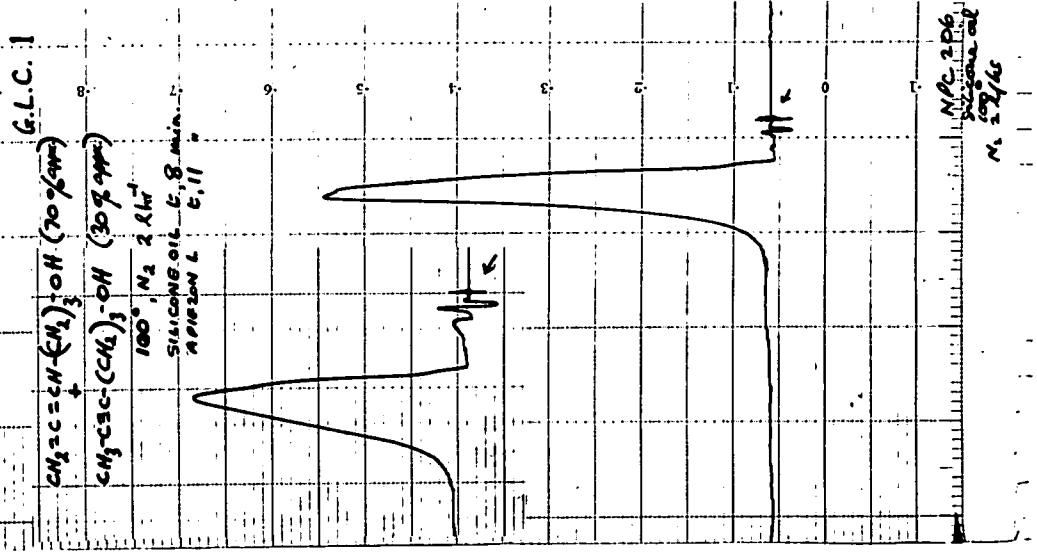

M.C. 206
Silicone oil
M. 2/4/65

M.C. 206
120°
H₂ 8 ATM

REFERENCES

References

1. W.v.E.Doering and A.K.Hoffman, J.Amer.Chem.Soc., 1954, 76, 6162.
2. J.Hine and A.M.Dowell, Jr., J.Amer.Chem.Soc., 1954, 76, 2688; J.Hine, R.Butterworth and P.B.Langford, J.Amer.Chem.Soc., 1958, 80, 819.
3. W.E.Parham and E.E.Schweizer, J.Org.Chem., 1959, 24, 1733.
4. F.W.Grant and W.B.Cassic, J.Org.Chem., 1966, 31, 1554.
5. W.Miller and C.S.Y.Kim, J.Amer.Chem.Soc., 1959, 81, 5008; V.Franzen and L.Finketscher, Chem.Ber., 1962, 95, 1958.
6. W.M.Wagner, H.Kloosterziel and A.F.Bickell, Rec.Tra.Chim., 1962, 81, 925, 933.
7. D.Seyferth, J.M.Burlitch and J.K.Heeren, J.Org.Chem., 1962, 27, 1491.
8. W.M.Wagner, H.Kloosterziel and S.Van der Ven, Rec.Tra.Chim., 1961, 80, 740.
9. D.Seyferth, R.J.Minasz, J.A.Treiber, J.M.Burlitch and S.R.Dowd, J.Org.Chem., 1963, 28, 1163.
10. A.Ledwith, "The Chemistry of Carbenes", Lectures Series, R.I.C., No.5, 1964; W.Kirmse "Carbene Chemistry", Academic Press, New York, 1964; Organic Reactions, 13, 55.
11. V.Franzen, Chem. Ber., 1962, 95, 1964.

12. J.P.Oliver and U.V.Rao, J.Org.Chem., 1966, 31, 2696.
13. W.v.E.Doering and P.LaFlamme, J.Amer.Chem.Soc., 1956, 78, 5447.
14. P.S.Skell and A.Y.Garner, J.Amer.Chem.Soc., 1956, 78, 5430; P.S.Skell and R.C.Woodworth, J.Amer.Chem.Soc., 1959, 81, 3383.
15. G.Wittig and K.Schwarzenbach, Ang.Chem., 1962, 650, 1.
16. H.Hoberg, Ann., 1962, 656, 15.
17. E.C.Herrick and M.Orchin, J.Org.Chem., 1959, 24, 139; N.P.Neuriter, J.Org.Chem., 1959, 24, 2044; A.Ledwith and R.M.Bell, Chem.Ind., 1959, 459.
18. L.Skattebøl, J.Org.Chem., 1964, 29, 2951.
19. W.J.Ball and S.R.Landor, Proc.Chem.Soc., 1961, 246.
20. A.Bezaguet, Compt.Rend., 1962, 254, 3371.
21. L.VoQuong, M.VoQuong, G.Emptoz and P.Saviguat, Compt. Rend., 1966, 262, 220.
22. M.Bertrand and A.Bezaguet, Compt.Rend., 1966, 262, 1697.
23. V.Franzen, unpublished results quoted by W.Kirmse, ref.10, p.162.
24. R.Kuhn and K.Wallenfels, Chem.Ber., 1938, 783.

25. K.Brand, ~~Chem.~~ Ber., 1921, 1987.
26. Reviewed by P.Cadiot, W.Chodkiewicz and J.Ranss-Godineau, Bull.Soc.Chim., 1961, 2176.
27. W.Chodkiewicz, P.Cadiot and A.Willemart, Compt.Rend., 1955, 240, 1554; W.Chodkiewicz and P.Cadiot, Compt. Rend., 1955, 240, 1903.
28. K.Brand and A.Busse-Sundermann, Chem.Ber., 1950, 83, 119.
29. A.Nakumura, P.Kim and N.Hagihara, J.Org.Met.Chem., 1965, 3, 355.
30. W.M.Schubert, T.H.Liddicoet and W.A.Lanka, J.Amer. Chem.Soc., 1954, 76, 1929.
Y.Zalkind, V.Teterin and S.Kuznetsov, J. Gen. Chem. (U.S.S.R.), 1946, 16, 611.
31. ~~G.Kobrich and H.Heineman, Ang.Chem., 1965, 594.~~
32. L.Skattebøl, Tetrahedron, 1965, 21, 1357.
33. G.Maier, Tetrahedron Letters, 1965, 40, 3603.
34. F.T.Bond and D.E.Brodway, J.Amer.Chem.Soc., 1965, 87, 607.
35. L.Jacobs and R.J.Baner, J.Amer.Chem.Soc., 1959, 81, 607.
36. E.L.Martin and W.H.Sharkey, J.Amer.Chem.Soc., 1959, 81, 5256.
37. P.K.Christiansen, N.A.Sorensen, I.Bell, E.R.H.Jones and M.C.Whiting, Festschrift Arther Stoll (Birkhäuser Basel), 1957, 545.

38. Bohlmann, H. Bornowski and C. Arendt, Chem. Ber., 1965, 98, 2236.
39. R. Kuhn, H. Fischer and H. Fischer, Chem. Ber., 1964, 97, 1760.
40. L. Skattebøl, Tetrahedron Letters, 1965, 26, 2175; J. Org. Chem., 1966, 31, 2789.
41. E. M. Kosower and T. S. Sorensen, J. Org. Chem., 1963, 28, 687.
42. A. C. Cope and E. M. Hardy, J. Amer. Chem. Soc., 1940, 62, 441.
43. E. G. Foster, A. C. Cope and F. D. Daniels, J. Amer. Chem. Soc., 1947, 69, 1893.
44. A. C. Cope, C. F. Hofmann and E. M. Hardy, J. Amer. Chem. Soc., 1941, 63, 1852.
45. H. Levy and A. C. Cope, J. Amer. Chem. Soc., 1944, 66, 1684.
46. A. C. Cope, L. Field, D. W. H. MacDowell and M. E. Wright, J. Amer. Chem. Soc., 1956, 78, 2547.
47. H. P. Koch, J. Chem. Soc., 1948, 1111.
48. "Molecular Rearrangements", Edited by P. DeMayo, Interscience, 1963-4, vol. 1-2.
49. R. B. Woodward and T. J. Katz, Tetrahedron, 1959, 5, 70.
50. R. P. Lutz and J. D. Roberts, J. Amer. Chem. Soc., 1961, 83, 2198.

51. W.v.Doering and W.R.Roth, Tetrahedron, 1963, 19, 715.
52. E.J.Corey and M.Chaykovski, J.Amer.Chem.Soc., 1962, 84, 866, 3782.
53. E.J.Corey and M.Chaykovski, J.Amer.Chem.Soc., 1965, 87, 1353.
54. P.T.Izzo, J.Org.Chem., 1963, 28, 1713.
55. H.König, H.Metzger and K.Seelert, Chem.Ber., 1965, 98, 3712.
56. C.Kaiser, B.M.Trost, J.Beeson and J.Weinstock, J.Org.Chem., 1965, 30, 3972.
57. W.A.Bernett, Journal of Chemical Education, 1967, 44, 17.
58. G.G.Gustavson and N.Demjanoff, J.Prakt.Chem., 1888, 386, 202; M.Bouis, Bull.Soc.Chim., 1927, 41, 1160.
59. W.D.Celmer and I.A.Solomons, J.Amer.Chem.Soc., 1952, 74, 2245; 1953, 75, 1372, 3430.
60. M.Anchel, J.Amer.Chem.Soc., 1952, 74, 1588.
61. J.D.Bu'Lock, E.R.H.Jones and P.R.Leeming, J.Chem.Soc., 1955, 4270.
62. J.D.Bu'Lock, E.R.H.Jones and P.R.Leeming, J.Chem.Soc., 1957, 1097.
63. E.R.H.Jones, P.R.Leeming and W.A.Remers, J.Chem.Soc., 1960, 2257.

64. R.C.Cambie, A.Hirschberg, E.R.H.Jones and G.Lowe, J.Chem.Soc., 1963, 4120.
65. M.O.Bagley, C.R.Smith and I.A.Wolff, Chem.Ind., 1964, 1861.
66. M.O.Bagley, C.R.Smith and I.A.Wolff, J.Org.Chem., 1965, 30, 4227.
67. A.Arnand, Bull.Soc.Chim., 1892, 7, 233; 1902, 27, 484.
68. H.W.Sprecher, R.Maier, M.Barber and R.H.Holman, Biochemistry, 1965, 4, 1856.
69. A.E.Favorski, J.Prakt.Chem., 1888, 37, 392.
70. Y.I.Ginzburg, J.Gen.Chem.U.S.S.R., 1940, 10, 513; Zhur.Obs.Khim., 1945, 15, 442.
71. T.L.Jacobs, E.G.Teach and D.Weiss, J.Amer.Chem.Soc., 1955, 77, 6254.
72. T.L.Jacobs, D.Danker and S.Singer, Tetrahedron, 1964, 20, 2177.
73. W.v.E.Doering and P.LaFlamme, Tet.Let., 1958, 2, 75.
74. W.R.Moore and H.R.Ward, J.Org.Chem., 1960, 25, 2073; 1962, 27, 4179.
75. G.F.Hennion and J.J.Sheehan, J.Amer.Chem.Soc. 1949, 71, 1964.
76. W.J.Bailey and C.R.Pfeifer, J.Org.Chem., 1955, 20, 95.

77. P.D.Gardner and M.Narayana, J.Org.Chem., 1961, 26, 3518; L.Skattebøl, Chem.Ind., 1962, 2146.
78. T.L.Jacobs and R.D.Wilcox, J.Amer.Chem.Soc., 1964, 86, 2240.
79. T.Shono and R.Oda, J.Chem.Soc.Japan, 1959, 80, 1200.
80. L.VoQuang and P.Cadiot, Compt.Rend., 1961, 252, 3827.
81. T.A.Dyakonov and L.P.Danilkina, Zh.Obs.Khim., 1962, 32, 1008.
82. D.R.J.Laws, Ph.D.thesis, London 1965 and ref.70.
83. S.R.Landor, A.N.Patel, P.F.Whiter and P.M.Greaves, J.Chem.Soc., 1966, 1223.
84. S.R.Landor and P.F.Whiter, J.Chem.Soc., 1965, 5625.
85. D.K.Black and S.R.Landor, J.Chem.Soc., 1965, 5225.
86. A.C.Cope, K.E.Hoyle and D.Heyl, J.Amer.Chem.Soc., 1941; 63, 1843.
87. A.C.Cope, C.M.Hofmann, C.Wyckoff and E.Hardenbergh, J.Amer.Chem.Soc., 63, 3452.
88. A.C.Cope and E.M.Hancock, J.Amer.Chem.Soc., 1938, 60, 2644.
89. F.Sarratosa, Tetrahedron Letters, 1964, 16, 895.
90. L.Groizeleau-Miginiac, Compt.Rend., 1959, 248, 1190.

91. D.K.Black and S.R.Landor, Tetrahedron Letters, 1963, 1065.
92. H.E.Simmons and R.D.Smith, J.Amer.Chem.Soc., 1958, 80, 5323; 1959, 81, 4256; H.E.Simmons, E.P.Blanchard and R.D.Smith, J.Amer.Chem.Soc., 1964, 86, 1347.
93. H.Hoberg, Ang.Chem., 1961, 73, 114; Ann., 1962, 656, 1.
94. E.Le Goff, J.Org.Chem., 1964, 29, 2048.
95. Y.Inouye, K.Takehana, S.Sawada and M.Ohno, Bull.Inst. Chem.Res., Kyoto Uni., 1966, 24, 203.
96. Ref.119, footnote, p.442; ref.92, p.5323 and 4258.
97. Hauser and Hudson, Organic Reactions (John Wiley & Sons Ltd., 1942), Vol.1, p.266.
98. E.J.Correy and M.Chaykovski, J.Amer.Chem.Soc., 1964, 86, 1940.
99. J.C.Powers, R.S.Siedner, T.G.Parsons and H.J.Bermin, J.Org.Chem., 1966, 31, 2623.
100. N.H.Dyson, J.A.Edwards and J.H.Fried, Tetrahedron Letters, 1966, 17, 1841.
101. E.R.H.Jones, Proc.Chem.Soc., 1960, 199; J.D.Bu'Lock, Progress in Chemistry, (Butterworths, 1964), p.86.
102. J.Ido and Kishida, Tetrahedron Letters, 1966, 16, 1789.
103. A.D.Walsh, Trans.Faraday Soc., 1949, 45, 179; G.L.Closs and H.B.Klinger, J.Amer.Chem.Soc., 1965, 87, 3265; A.L.Goodman and R.H.Eastman, J.Amer.Chem.Soc., 1964, 86, 908.

104. C.A.Coulson and W.E.Mofit, *Phil.Mag.*, 1949, 40, 1.
105. L.J.Smith and E.R.Rogier, *J.Amer.Chem.Soc.*, 1951, 73 3840.
106. R.H.Eastman, *J.Amer.Chem.Soc.*, 1954, 76, 4115.
107. R.H.Eastman and S.K.Freeman, *J.Amer.Chem.Soc.*, 1955, 77, 6642.
108. R.B.Woodward, *J.Amer.Chem.Soc.*, 1941, 63, 1123; 1942, 64, 72; Fieser and Fieser, "Steroids" (Reinhold, N.Y., 1959), Ch.1; Nielson, *J.Org.Chem.*, 1957, 22, 1539.
109. J.D.Roberts and R.H.Mazur, *J.Amer.Chem.Soc.*, 1951, 73, 3542.
110. R.B.Woodward, *J.Amer.Chem.Soc.*, 1942, 64, 76.
111. J.C.D.Brand and G.Eglinton, *Application of Spectroscopy in Organic Chemistry* (Oldbourne, 1965), 159.
112. E.F.Ulman and W.J.Fanshawe, *J.Amer.Chem.Soc.*, 1961, 83, 2370.
113. D.J.Patel, M.E.H.Howden and J.D.Roberts, *J.Amer.Chem.Soc.*, 1963, 85, 3218.
114. H.Weitkamp, U.Hasserodt and F.Korte, *Chem.Ber.*, 1962, 95, 2280.
115. P.M.Greaves, Ph.D. thesis, Durham, 1967.
116. I.Tömösközi, *Tetrahedron*, 1963, 19, 1969.

117. Y.I.Inouye and H.M.Walborsky, *J.Org.Chem.*, 1962, 27, 2706.
118. T.Sugita and Y.Inouye, *Bull.Chem.Soc. Japan*, 1966, 39, 1075.
119. H.Nozaki, H.Ito, D.Tunemoto and K.Kondo, *Tetrahedron*, 1966, 22, 441.
- 120., R.F.Nystrom and W.G.Brown, *J.Amer.Chem.Soc.*, 1948, 70, 3738; also ref. 122 and 123.
121. A.N.Patel, Ph.D thesis, London 1961.
122. L.J.Haynes, I.M.Heilbron, E.R.H.Jones and F.Sondheimer, *J.Chem.Soc.*, 1947, 1583.
123. E.B.Bates, E.R.H.Jones and M.C.Whiting, *J.Chem.Soc.*, 1954, 1854.
124. J.F.Arens, J.H.van Boom, P.P.Montijn and L.Brandtsma, *Rec.Tra.Chim.*, 1965, 84, 271.
125. A.L.Henne and K.W.Greenlee, *J.Amer.Chem.Soc.*, 1945, 67, 484.
126. A.Luttringhaus and D.Schade, *Chem.Ber.*, 1941, 24, 1565.
127. R.J.D.Evans, Ph.D.thesis, London 1963.
128. B.J.Miller, Ph.D.thesis, London 1966.
129. D.K.Black, Ph.D.thesis, London 1963.

130. S.R.Landor, B.J.Miller and A.R.Tatchell, J.Chem.Soc., 1966, 2280; 1967, 197.
131. S.R.Landor, B.J.Miller, J.P.Regan^M and A.R.Tatchell, J.Chem.Soc., Chem.Com., 1966, 585.
132. J.P.Regan, Ph.D.thesis, Durham 1967.
133. J.H.Brewster, J.Amer.Chem.Soc., 1959, 81, 5475.
134. G.Lowe, Chem.Comm., 1965, 441.
135. S.P.Barton, D.Burn, G.Cooley, E.Ellis and V.Petrow, J.Chem.Soc., J.Chem.Soc., 1957, 1959; D.N.Robertson, J.Org.Chem., 1960, 25, 931.
136. E.S.Pepper, Ph.D.thesis, London 1965; P.D.Landor, S.R.Landor and E.S.Pepper, J.Chem.Soc., 1966, 2183.
137. H.B.Henbest, E.R.H.Jones and I.M.S.Walls, J.Chem.Soc., 1950, 3646.
138. A.C.Ott, M.F.Murray and R.L.Rederson, J.Amer.Chem.Soc., 1952, 74, 1239.
139. E.Sherman and E.D.Amstutz, J.Amer.Chem.Soc., 1950, 72, 2195.
140. P.D.Landor, S.R.Landor and E.S.Pepper, J.Chem.Soc., 1967, 185.
141. W.Traube and E.Lehman, ~~Chem.~~ Ber., 1901, 34, 1971.
142. Organic Synthesis Collected Vol.IV, p.10.

143. N.Kornblum, W.J.Jones and G.J.Anderson, J.Amer.Chem. Soc., 1959, 81, 4113; A.P.Johnson and A.Petter, J.Chem.Soc., 1964, 520.
144. I.M.Hunsberger and J.M.Tien, Chem.Ind., 1959, 88.
145. Chemical Reviews, 1967, 67, 247.
146. H.Finkelstein, Chem.Ber., 1910, 43, 1528
147. L.F.Hatch and L.E.Kidwell, Jr., J.Amer.Chem.Soc., 1954, 76, 289.
148. D.Seyferth and J.M.Burlitch, J.Organometallic Chem., 1965, 4, 127.
149. V.Prelog and H.Scherrer, Helv.Chim.Act., 1959, 42, 2227.
150. G.W.Cannon, A.A.Santilli and P.Shenian, J.Amer.Chem. Soc., 1959, 81, 1660.
151. R.Ramband, Bull.Soc.Chim., 1938, 5, 1552.
152. A.I.Vogel, "A Text-Book of Practical Organic Chemistry (Longmans, 1956), 890.
153. E.F.Cox, M.C.Caserio, M.S.Silver and J.D.Roberts, J.Amer.Chem.Soc., 1961, 83, 2719.
154. I.N.Nazarov, Z.A.Krasnaya and V.P.Vinogradov, Zhu.Obs.Khim., 1958, 28, 460.
155. A.Burger and W.L.Yost, J.Amer.Chem.Soc., 1948, 70, 2198.

156. S.Sugden and H.Wilkins, J.Chem.Soc., 1927, 139.
157. A.Wassermann, Hel.Chim.Acta., 1930, 13, 213, 229.
158. M.Julia, S.Julia and J.A.du Chaffaut, Bull. Soc. Chim., 1960, 1735. The difference in m.p. might be due to different geometric isomers of the hydrazone.
159. R.Kuhn and H.Trischmann, Ann., ^{1958,} 611, 117.
160. I.Heilbron, E.R.H.Jones and F.Sondheimer, J.Chem. Soc., 1949, 604; R.E.Bew, R.C.Cambie, E.R.H.Jones and G.Lowe, J.Chem.Soc., 1966, 2, 135.
161. E.I.Snyder and J.D.Roberts, J.Amer.Chem.Soc., 1962, 84, 1582.
162. G.R.Harvey and K.W.Ratts, J.Org.Chem., 1966, 31, 3907; G.Eglinton, E.R.H.Jones, G.H.Mansfield and M.C.Whiting, J.Chem.Soc., 1954, 3197.
163. E.Fischer and A.Dilthey, Ann., 1904, 335, 338.
164. E.R.H.Jones, Chemistry in Britain, ^{1967,} 2 (1), 6.
-

