

Durham E-Theses

Studies directed towards the step-growth photopolymerization of carbonyl compounds

Spanomanolis, Constantinos

How to cite:

Spanomanolis, Constantinos (1978) *Studies directed towards the step-growth photopolymerization of carbonyl compounds*, Durham theses, Durham University. Available at Durham E-Theses Online:
<http://etheses.dur.ac.uk/8406/>

Use policy

The full-text may be used and/or reproduced, and given to third parties in any format or medium, without prior permission or charge, for personal research or study, educational, or not-for-profit purposes provided that:

- a full bibliographic reference is made to the original source
- a [link](#) is made to the metadata record in Durham E-Theses
- the full-text is not changed in any way

The full-text must not be sold in any format or medium without the formal permission of the copyright holders.

Please consult the [full Durham E-Theses policy](#) for further details.

**STUDIES DIRECTED TOWARDS THE STEP-GROWTH PHOTOPOLYMERIZATION
OF CARBONYL COMPOUNDS**

by

Constantinos Spanomanolis, B.Sc.

(Graduate Society)

The copyright of this thesis rests with the author.
No quotation from it should be published without
his prior written consent and information derived
from it should be acknowledged.

**A thesis submitted to the University of Durham for the Degree of
Doctor of Philosophy**

1978



Non sien le genti, ancor, troppo sicure
a giudicar, si comme quei che stima
le biade in campo pria che sien mature:
ch' i' ho veduto tutto il verno prima
lo prun mostrarsi rigido e feroce,
poscia portar la rosa in su la cima;
e legno vidi gia dritto e veloce
correr lo mar per tutto suo cammino,
perire al fine all' intrar de la foce.

Dante Alighieri, 'La Divina Commedia',
Paradiso, Canto XIII, 130 - 138.

'So also let not the people be too sure in judging, like
those that reckon the corn in the field before it is ripe:
for I have seen the briar first show all harsh and rigid
through the winter and later bear the rose upon its top;
and once I saw a ship that ran straight and swift over the
sea through all its course and perish at the last entering
the harbour.'

To the Memory of my Mother

ABSTRACT

Studies Directed Towards the Step-Growth Photopolymerization
of Carbonyl Compounds

This thesis describes some work carried out in the relatively new area of step-growth photopolymerization of carbonyl compounds.

The possibility of extending the photoreductive polymerization of aromatic diketones (leading to the synthesis of polybenzopinacols) to the photochemical synthesis of pentaphenylglycerols and higher analogues was investigated; however examination of the model photochemical reaction between benzophenone and triphenylglycol established that this glycol (and the related 1,2,2,2-tetraphenylethanol) is not a hydrogen donor for triplet benzophenone.

In an attempt to examine the possibility of extending the photoreductive addition of benzophenone to diphenylmethane to polymer synthesis, m-dibenzoylbenzene and m- and p-dibenzylbenzenes were prepared and characterized. Irradiation of the diketone in the presence of an equimolar amount of either of the dibenzylbenzenes afforded low molecular weight products, shown by ^1H and ^{13}C n.m.r. spectroscopy to contain benzopinacol, tetraphenylethane and 1,1,2,2-tetraphenylethanol type of units, in addition to benzophenone-type carbonyl and benzyl groups. Results obtained from the pyrolytic decomposition or treatment with dehydrating agents of one of the products were consistent with the proposed structure.

Irradiation of tere- or iso-phthalaldehyde in the solid state yielded mostly starting materials whereas branched low molecular weight products were obtained from the irradiation of either of these aromatic dialdehydes in the presence of the hydrogen-donating isopropanol.

An investigation on the structure of the 'photopolymer' produced on irradiating benzaldehyde in the liquid phase, by means of conventional

spectroscopic analyses did not lead to a convincing structural hypothesis. 'Classical' chemical reactions proved to be more useful in this case; it was thus shown that the 'photopolymer', which has the same elemental composition as benzaldehyde but a molecular weight 9 - 11 times as high, can be acetylated, oxidized and is reactive towards sulphuric acid; it is furthermore stable to irradiation in benzene solution at 300nm in the absence of air and non-photo-reducible in isopropanol; it is however reduced by either sodium borohydride or sodium bis(2-methoxyethoxy)-aluminium hydride giving rise to a different structure in each case.

Finally an extension of the Paternò-Büchi reaction of perfluoro compounds to polymer synthesis was attempted by examining the cycloaddition of perfluoroglutaryl fluoride to two perfluoroolefins under a variety of experimental conditions. This work was largely unsuccessful and the rationalization of the results obtained will be found in the last Chapter of this thesis.

ACKNOWLEDGEMENTS

The author is indebted to Dr. W.J. Feast for his continued help and encouragement unfailingly given during the supervision of this work. His patience and understanding, both on the professional and personal level, have been invaluable to the author.

Thanks are due to Dr. R.S. Matthews for running n.m.r. spectra, Dr. B.J. Cromarty for translating papers from German, and Drs. G.M. Brooke and C.D. Bartlett for helpful suggestions.

Assistance from members of the technical and laboratory staff is greatly appreciated; in particular assistance from Mrs. S.E. Robson for running i.r. spectra and Mr. D. Hunter for practical advice is gratefully acknowledged.

Discussions with the other members of the Research Laboratory '25' have been particularly helpful and their collaboration is also appreciated.

The author thanks the European Research Office of the U.S. Army for the award of a maintenance grant and Mr. Apostolos Spanomanolis of 'Christos Spanomanolis Sons', Athens, Greece, for some financial support.

Finally thanks are due to Mrs. E. Duddy and Miss A. Laing for typing this thesis, and Mr. M. Strange for helping with some of the drawings.

MEMORANDUM

The work described in this thesis was carried out in the Chemistry Laboratories of the University of Durham between September 1975 and August 1978. This work has not been submitted for any other degree and is the original work of the author, except where acknowledged by reference.

STUDIES DIRECTED TOWARDS THE STEP-GROWTH PHOTOPOLYMERIZATION OF CARBONYL
COMPOUNDS

TABLE OF CONTENTS

	<u>Page No.</u>
Abstract	iii
Acknowledgements	v
Memorandum	vi
Table of Contents	vii
 <u>CHAPTER 1: GENERAL INTRODUCTION AND BACKGROUND</u>	
1.1. <u>Photopolymerization Redefined</u>	1
1.2. <u>Photopolymerization Via the Singlet Manifold</u>	2
1.3. <u>Photopolymerization Via the Triplet Manifold</u>	4
1.4. <u>Photopolymerization Via a Reactive Ground State Species Formed in an Initial Photochemical Reaction</u>	8
1.5. <u>Step-Growth Photopolymerization in the Solid State</u>	9
1.6. <u>Origins of Current Work</u>	10
1.7. <u>Brief Introduction into the Photochemistry of Carbonyl Compounds</u>	13
 <u>CHAPTER 2: PHOTOREDUCTIVE POLYMERIZATION OF AROMATIC BISKETONES</u>	
2.1. <u>Introduction</u>	17
2.1.a. Historical Background	17
2.1.b. Some Aspects of Relevant Photochemistry	32
2.1.b.i. Introductory Survey	32
2.1.b.ii. Spin Flipping and Reactions within the Solvent Cage	38
2.1.b.iii. The Yellow Intermediate Observed in the Photoreduction of Aromatic Ketones	41
2.1.b.iv. Complex Formation between Ketyl Radical and Ketone	43
2.1.b.v. Effect of Structure on Photoreduction of Aromatic Ketones	47

	<u>Page No.</u>
2.1.b.vi. Steric Effects on Photoreduction	50
2.1.b.vii. The Temperature Effect on Photoreduction	52
2.1.b.viii. Photoreductive Addition of Ketones to Methylene Groups	53
2.1.c. Objectives of the Study	54
2.2. <u>Attempts to Synthesize Poly(pentaphenylglycerols) and Higher Analogues</u>	57
2.2.a. Introduction to the Idea	57
2.2.b. How One Event Led to Another	59
2.2.c. The 'Prehistory' of Organic Photochemistry - the Nature of a Dispute	61
2.2.d. The Resolution of the Dispute	64
2.2.e. Ground State Synthesis of Triphenylglycol	67
2.2.f. The Benzophenone/Triphenylglycol Photoreaction	67
2.2.g. The Photoreactivity of 1,2,2,2-Tetraphenylethanol	72
2.2.h. Some Relevant Photoreactions	73
2.2.i. Attempts to Prepare Pentaphenylglycerol Via Ground State Chemistry	74
2.2.j. Experimental	79
2.2.j.i. Readily Available Materials	79
2.2.j.ii. Solvents	80
2.2.j.iii. Materials Synthesized from Simpler Chemicals	80
2.2.k. Discussion and Conclusions	85
2.3. <u>Use of the Diphenylmethane/Benzophenone Reaction as the Polymer Building Step</u>	89
2.3.a. Details of Model Reaction	90
2.3.a.1. Discussion of Literature	90
2.3.a.ii. Experimental Results	94
2.3.a.iii. Comments on Literature Claims in the Light of Present Results	97

	<u>Page No.</u>
2.3.b. Synthesis of Monomers	104
2.3.b.i. Discussion of Possible Routes	104
2.3.b.ii. Selection of Routes	105
2.3.b.iii. Reasons for Failure	114
2.3.b.iv. Purification and Proof of Structure	116
2.3.c. Polymerization Runs	117
2.3.c.i. A Preliminary Investigation	117
2.3.c.ii. Examination of the Effect of Concentration	118
2.3.c.iii. Large Scale Experiments	121
2.3.d. Characterization of Products	123
2.3.e. Reactions of Polymers	128
2.3.e.i. Depolymerization	128
2.3.e.ii. Treatment with Dehydrating Agents	129
2.3.e.iii. Parallel Model Compound Studies	131
2.3.f. Experimental	134
2.3.f.i. Readily Available Materials	134
2.3.f.ii. Solvents	134
2.3.f.iii. Materials Synthesized from Simpler Chemicals	135
2.3.g. Discussion and Conclusions	135
 <u>CHAPTER 3: THE PRODUCTS OF IRRADIATION OF BENZALDEHYDE AND ITS</u> <u>DIFUNCTIONAL ANALOGUES</u>	
3.1. <u>Introduction</u>	141
3.1.a. Early Photochemical Investigations	141
3.1.b. Ground State Polymerization of Benzaldehyde and its Difunctional Analogues	145
3.1.c. The Photochemistry of Phthalaldehyde	147
3.1.d. Brief Introduction into the Photochemistry of Benzaldehyde	148
3.1.e. Original Ideas	151
3.2. <u>The Photochemistry of Tere- and Iso-phthalaldehyde</u>	152
3.2.a. Results	152

	<u>Page No.</u>
3.2.b. Discussion in the Light of Recent Knowledge	155
3.3. <u>The Benzaldehyde Photoproduct</u>	156
3.3.a. Recent Preparation and Spectral Characteristics	156
3.3.b. Experimental	157
3.3.b.i. Purification of Benzaldehyde	157
3.3.b.ii. Irradiations	158
3.3.b.iii. Purification of Product	159
3.3.b.iv. Attempted Characterization of the 'Photopolymer' of Benzaldehyde	160
3.3.c. Conclusion and Suggestions for Further Work	164
 <u>CHAPTER 4: STUDIES ON THE CYCLOADDITION OF PERFLUOROGLUTARYL- FLUORIDE TO SOME PERFLUOROOLEFINS</u>	
4.1. <u>The Paternò-Büchi Reaction</u>	168
4.1.a. Introduction	168
4.1.b. Mechanism	169
4.1.c. Limitations	171
4.2. <u>Application of the Paternò-Büchi Reaction to Polymer Synthesis</u>	173
4.3. <u>Applications of the Paternò-Büchi Reaction to Poly- fluorinated and Perfluoro Systems</u>	176
4.4. <u>The Photolysis of Acyl Fluorides</u>	183
4.5. <u>Original Idea</u>	186
4.6. <u>Experimental</u>	188
4.6.a. Starting Materials	188
4.6.b. Irradiations	190
4.6.c. Results	191
4.7. <u>Discussion</u>	191
4.8. <u>Conclusions</u>	196

Appendices and References

Appendix A - Apparatus, Instruments and General Techniques

Appendix B - Infrared Spectra

Appendix C - Lectures, Colloquia, Seminars and Conferences Attended

CHAPTER 1

General Introduction and Background

1.1. Photopolymerization Redefined.

The term photopolymerization is commonly understood to mean the initiation by light of a chain polymerization process, although more generally it implies the increase in molecular weight caused by light and therefore includes the photocrosslinking of macromolecules.^{1,2} The link between these two aspects of photopolymerization is the use of light as energy source and polymeric materials as the object of interest.

Photoinitiated vinyl polymerization has been the object of research interest since the turn of the century³ and a large volume of scientific and technological information has been published.⁴⁻⁸ The area remains one of intense activity both in academic and industrial laboratories and is also of considerable commercial importance in the surface coatings, electronics, printing and related industries.⁹⁻¹²

The use of photocrosslinking of polymeric materials has been traced back to the Babylonians,¹³ although the development of the area really begins with the work of Minsk on the synthesis of poly(vinylcinnamate). He also showed how the incorporation of dyes into coatings containing the polymer provided a means of photosensitizing the crosslinking reaction.^{14,15} This deliberate photocrosslinking is, like photoinitiated vinyl polymerization, an area of intense current activity and a topic with considerable commercial importance.^{11,12,16}

Crosslinking is commonly observed as a process competing with degradation in polymers exposed to light. In general terms such crosslinking is largely due to reactions of secondary polymer radicals formed by cleavage of groups or atoms from the main polymer chain. Actual crosslinking may occur by radical combinations or by additions to unsaturated sites in other chains. A number of examples of photochemical crosslinking of polymers and the related photochemical grafting of one monomer to a polymer may be found in the literature.^{13,17,18}



The preceding paragraphs very briefly describe reactions long classified under the general heading of photopolymerization. Over the last few years, however, there have been several reports of polymer syntheses of the step-growth type in which photochemical reactions are used in forming the bonds of a linear polymer chain in each propagation step. De Schryver and Smets have pointed out the need to re-examine the concept of photopolymerization. They have suggested that the term be reserved specifically for polymerization processes in which every chain propagation step involves a photochemical reaction,¹⁹ and in this sense photopolymerization is distinct from photo-initiated polymerization. De Schryver and Smets have pointed out that photopolymerizations can be divided into three classes according to the nature of the species involved in the propagation step, which may be a singlet excited state, a triplet excited state, or a reactive ground state resulting from a photochemical reaction.²⁰

1.2. Photopolymerization Via the Singlet Manifold.

The dimerization of anthracene at the 9,10 positions is a well established photochemical reaction proceeding via the singlet state.²¹ When bis-anthracenes are irradiated polymers can be obtained and it has been demonstrated that this reaction proceeds via the singlet manifold, and gives the head to tail product, as shown in Figure 1.1.^{22,23} Two points are particularly worthy of note, in the first place the reaction proceeds in the direction of polymer formation when the irradiation is carried out at 350 nm and depolymerization at below 300 nm wavelength; this serves to illustrate the importance of selecting the appropriate energy range for any particular photopolymerization process. Secondly, the degree of polymerization (d.p.) attainable in this reaction appears to depend on the nature of the group linking the two anthracene units in the monomer, thus for monomers of structure I significantly lower d.p.'s were obtained on irradiation than for monomers of structure II (Figure 1.2).^{22,23}

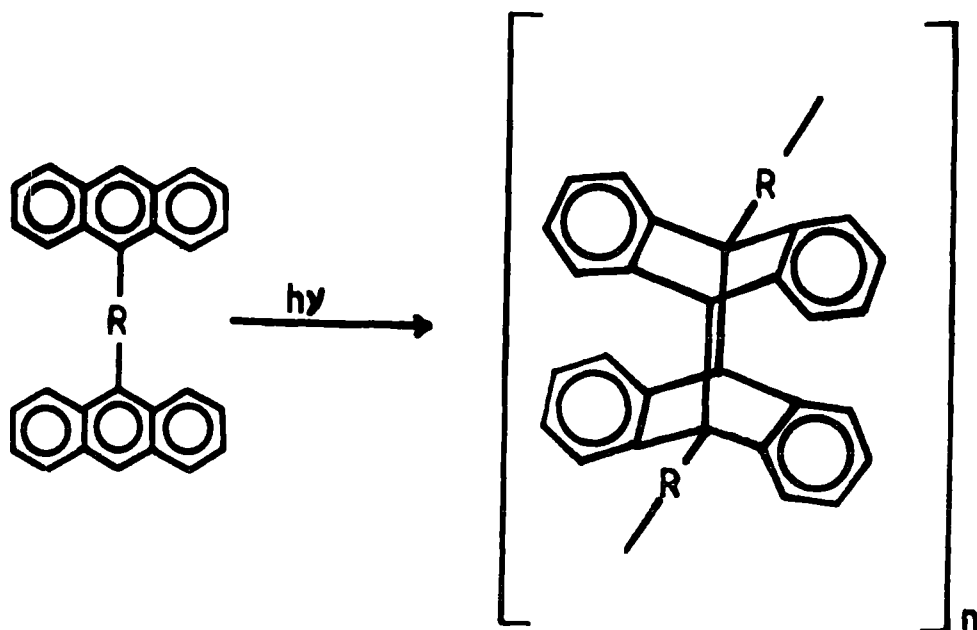


Figure 1.1

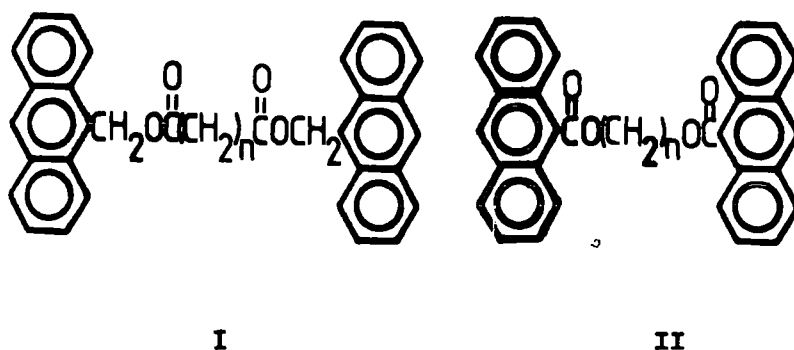


Figure 1.2

The explanation of the discrepancy lies in the possibility of a chain growth terminating side reaction for structure I which does not exist for structure II, namely a 1,5-sigmatropic hydrogen shift from the methylene attached to C-9 to C-10.

This observation serves to illustrate the importance of understanding all the details of the photoreactions of monomers selected for use in step-growth photopolymerization.

1.3. Photopolymerization Via the Triplet Manifold.

Populating the excited state by way of energy transfer from an appropriate sensitizer ensures reaction on the triplet manifold and excludes intervention of singlet states of the monomer. One of the earliest examples of solution phase step-growth photopolymerization was the benzophenone sensitized polymerization of tetrachlorobismaleimides (Figure 1.3, III, X = Cl, R = $\{-CH_2\}_n$).^{19,24} A detailed study of the photochemistry of the bichromophoric system III by De Schryver and co-workers underlines the point, made in relation to the photopolymerization of bisanthracenes, that all possible aspects of the reaction and the properties of the reactants and products must be considered in

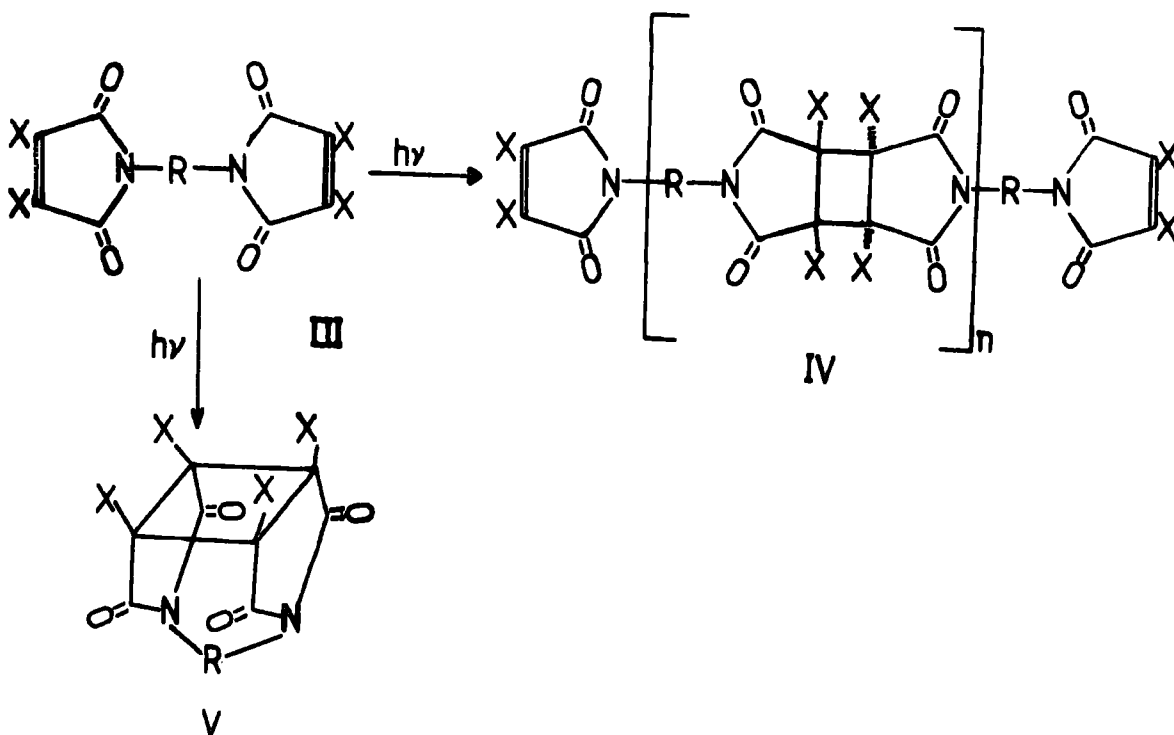


Figure 1.3

designing step-growth photopolymerization processes. Thus, although for tetrachlorobismaleimides (III, X = Cl, R = $\{-CH_2\}_n$) where n = 7, 9 or 11 irradiation of a solution of monomer and benzophenone in methylene chloride leads to genuine linear high polymers of structure IV, monomers where an even number of methylenes separate the maleimide units fail to reach high molecular

weight since the products precipitate from solution at a relatively low degree of polymerization. This is not the only restriction on the generality of the synthesis of polymers IV from monomers III. When the monomers having unsubstituted maleimide double bonds (III, X = H) are irradiated insoluble products are formed, presumably accounted for by crosslinking via vinyl polymerization at the double bonds. For some lengths of methylene sequence R monomeric cyclomers V are formed (Figure 1.3); the relative proportions of linear polymer (IV), cyclomer (V), and insoluble crosslinked product depend on the nature of the vinyl substituents X, the linking group R, and the reaction conditions such as the monomer concentration. A further factor which was emphasized by these authors²⁴ was how critically important very high reagent purity can be in reactions of this kind; thus, although no detectable difference was established between samples of tetrachlorobismaleimides purified by slightly different techniques one sample polymerized to genuine high polymer on irradiation in the presence of benzophenone whereas another sample was recovered as unchanged monomer after identical treatment; presumably traces of an effective triplet quencher constituted the difference between samples.

Other examples of photopolymerization via the triplet manifold include the irradiation of biscoumarins in the presence of benzophenone sensitizer²⁵ and the synthesis of polyoxetanes by irradiation of bisbenzophenones in the presence of equimolar amounts of the diolefins, tetramethylallene or furan.^{26,27}

The unsensitized photolysis of biscoumarins with short chain length ($n < 8$) yields exclusively endo cyclomers arising from the excited singlet manifold²⁸ (Figure 1.4, VI) while benzophenone sensitized reaction leads to high molecular weight polymers. The predominant exo head to head structure was established by ¹³C nmr spectroscopy (Figure 1.4, VII).

The case of photochemical reaction between benzophenone and tetramethylallene has been studied in detail and in addition to the oxetane structures

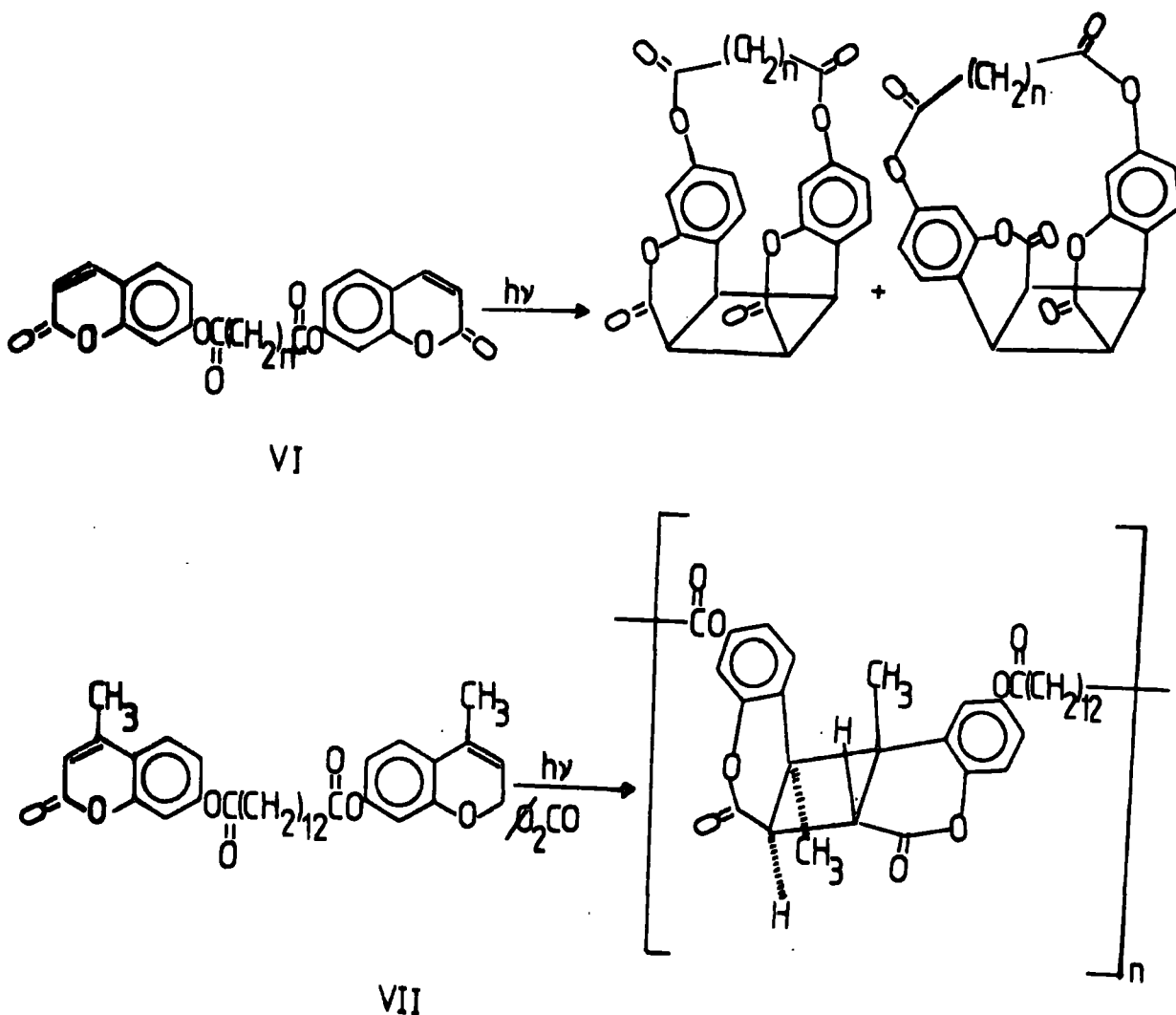


Figure 1.4

arising from cycloaddition there are three tertiary alcohols formed via initial abstraction of hydrogens from the methyl groups of tetramethylallene by triplet benzophenone followed by coupling of the ketyl and allyl radicals (Figure 1.5).²⁹ Products in Figure 1.5 account for over 98% of the overall mass balance. Approximately 90% of benzophenone molecules react by cycloaddition, the residual 10% reacting by initial abstraction of hydrogen from tetramethylallene.²⁹ In the light of this evidence one would expect irradiation of bisketones in the presence of equimolar amounts of tetramethylallene to yield copolymers of structure VIII, Figure 1.6 (together with isomeric structures).

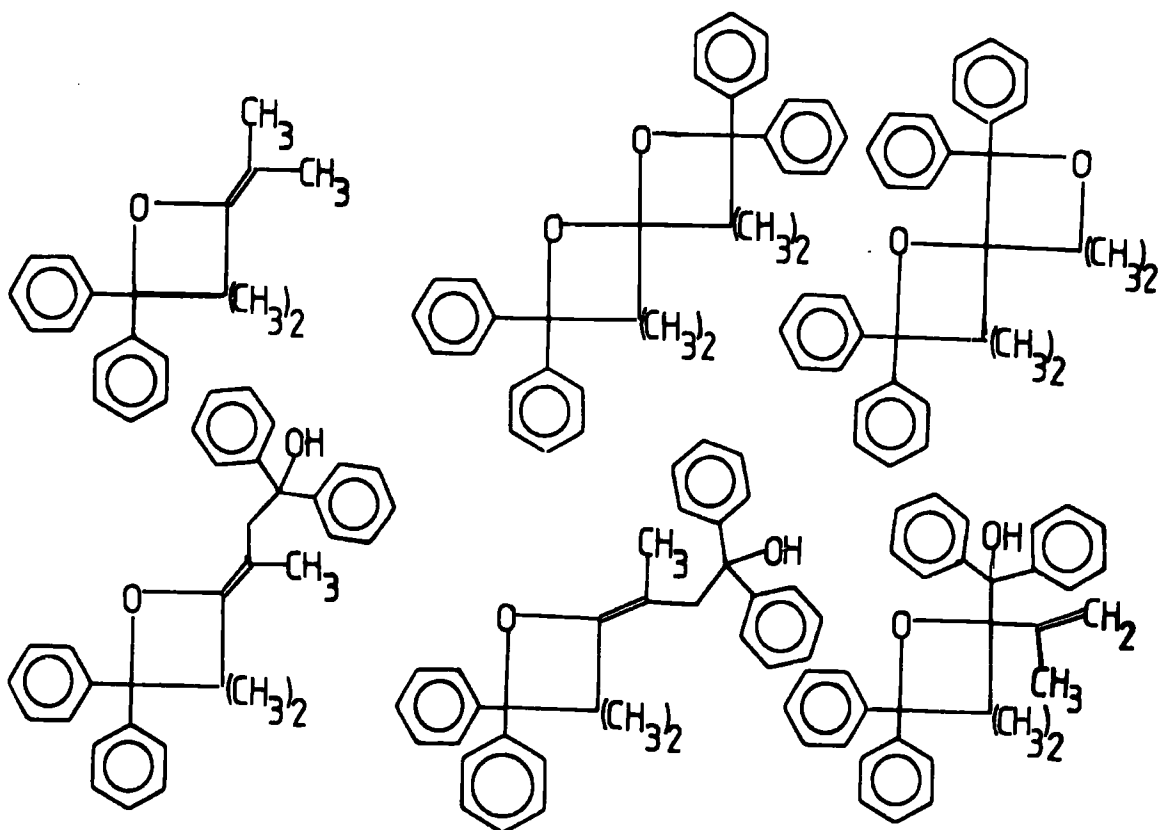
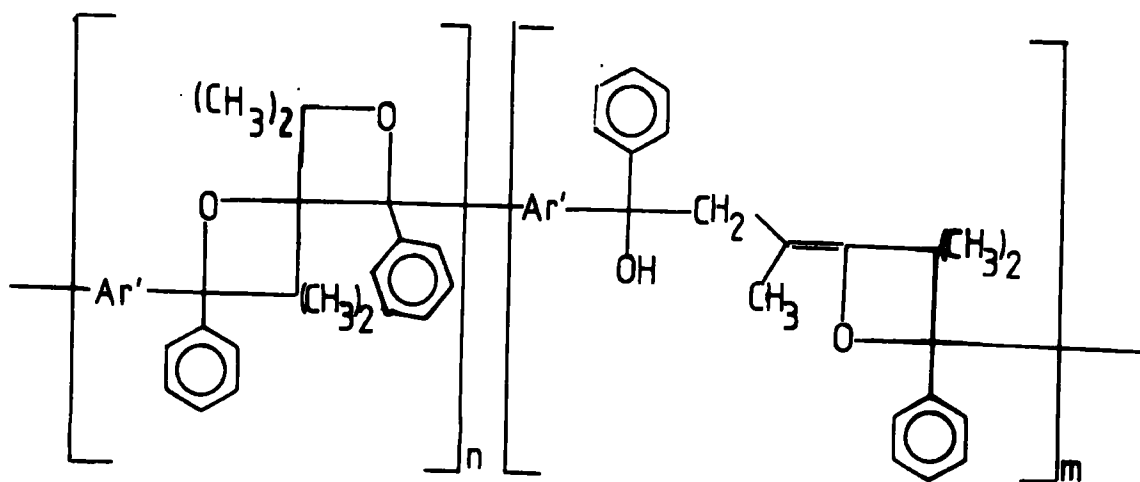


Figure 1.5



VIII

Figure 1.6

Such copolymers were recently reported²⁶ in which ca. 90% of the polymer chain links are oxetanes.

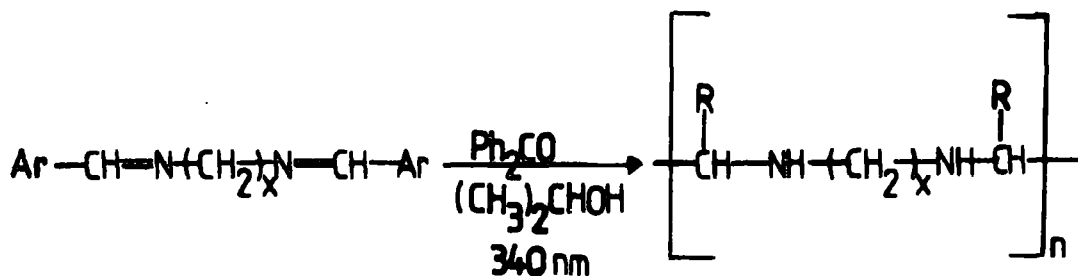
The use of furan as the reacting diene system (instead of tetramethylallene) presented special problems due to its volatility which were successfully overcome in the end resulting in the synthesis of linear polymers.²⁷

A more detailed examination of these cases confirms the restrictions on generality and the practical difficulties which apply to this area of polymer synthesis.

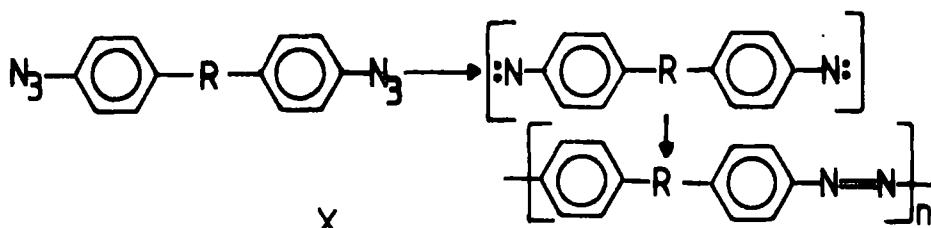
1.4. Photopolymerization Via a Reactive Ground State Species Formed in an Initial Photochemical Reaction.

The photochemical polyaddition of dibenzaldimines is an example of this class (Figure 1.7, IX). The reaction is benzophenone sensitized and proceeds via coupling of Ar-CH-NH-R type radicals.³⁰

Another example reported is the photopolymerization of bisazides, the propagation step of which is believed to proceed through a reactive nitrene intermediate³¹⁻³⁴ (Figure 1.7, X).



IX



X

Figure 1.7

Stevens and co-workers^{35,36} made use of the photocycloaddition of maleimide to benzene³⁷ and alkyl benzenes^{38,39} to synthesize linear polyimides (Figure 1.8). Reaction is thought to involve 2+2 cycloaddition of photo-excited maleimide to the aromatic ring followed by ground state Diels-Alder addition with a second maleimide unit.

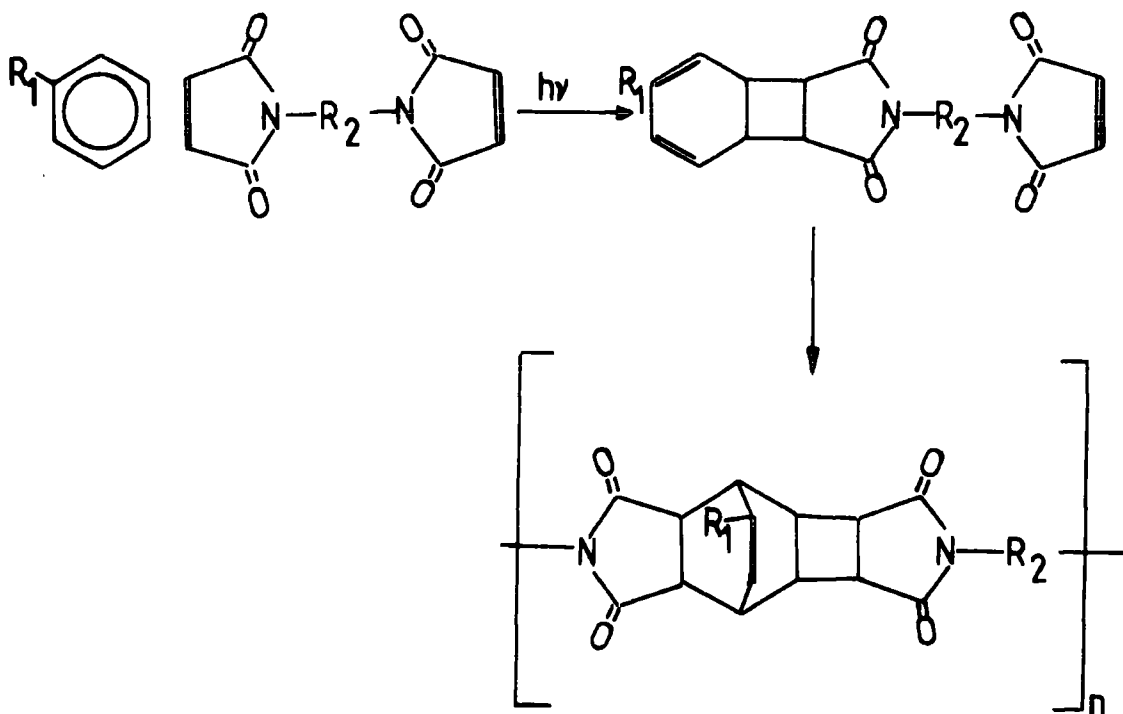


Figure 1.8

Another interesting example of this type of photopolymerization is the reductive coupling of aromatic diketones which affords polybenzopinacols.⁴⁰ Photoreductive polymerization will be dealt with in detail in Chapter 2 of this thesis.

1.5. Step-Growth Photopolymerization in the Solid State.

This field was initiated by Hasegawa and co-workers.⁴¹⁻⁴⁴ The photocyclodimerization of olefins to cyclobutane derivatives was applied to the solid state photocycloaddition polymerization of 2,5-distyryl pyrazine and

related structures (Figure 1.9, XI). The solid state photopolymerization was found to be topochemically controlled. The double bonds should be appropriately located one beside the other for the dimerization to take place. For instance, only one crystalline form of α, α' -bis(4-acetoxy-3-methoxybenzylidene)-p-benzenediacetonitrile was found to polymerize in the solid state (Figure 1.9, XII).⁴⁵

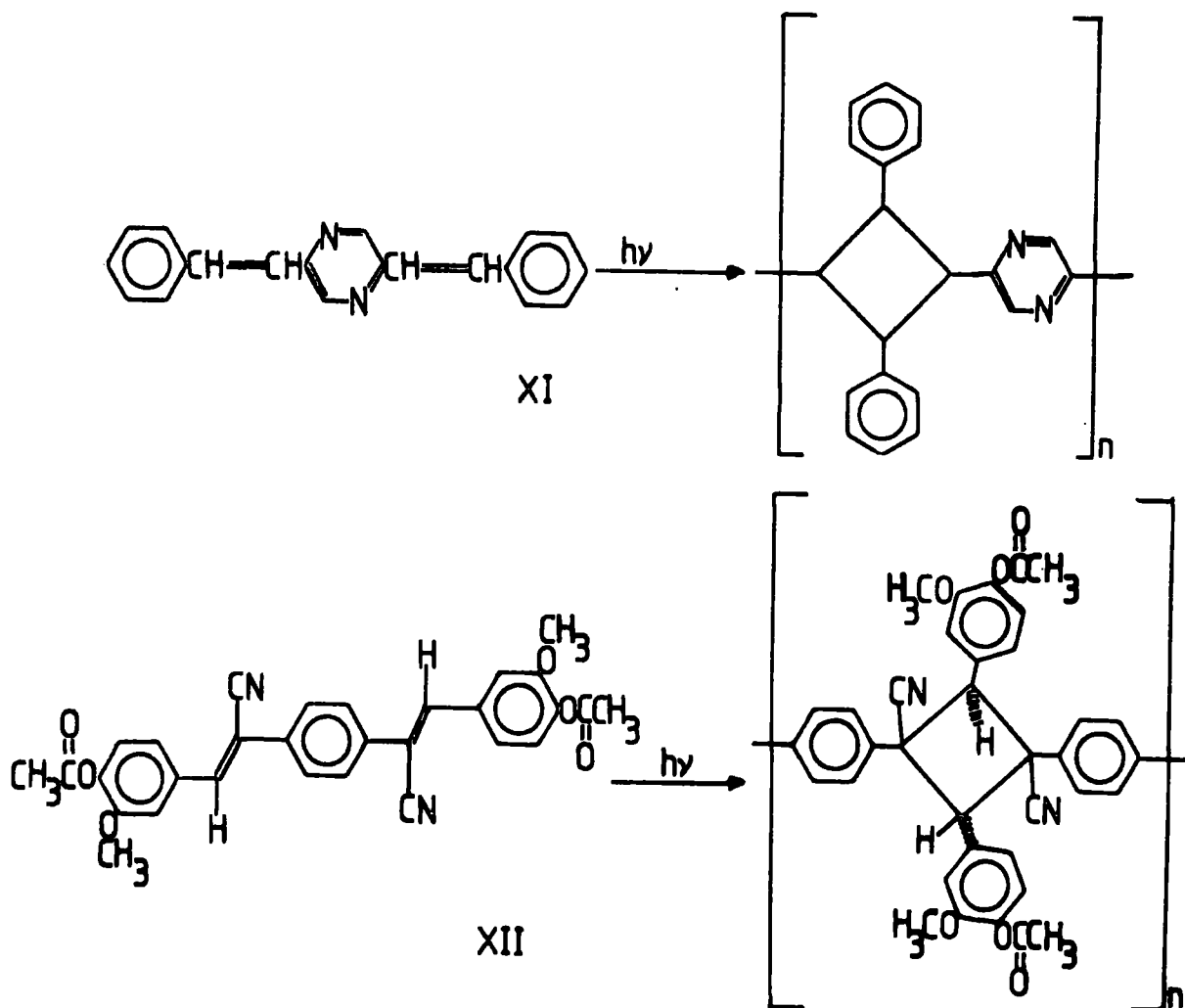


Figure 1.9

1.6. Origins of Current Work.

The successful photoreductive coupling of aromatic diketones and the synthesis of polyoxetane copolymers from equimolar mixtures of diketones and

diolefins are characteristic examples of the step-growth photopolymerization of carbonyl compounds. The work to be described in this thesis was intended as an attempt to extend the number of known examples in this area. To this end, a number of mono- and di-carbonyl compounds were synthesized and characterized; their photoreactivities under a variety of different conditions were examined, and reaction products were identified wherever possible.

The main reasons for undertaking this study were:

- (i) the desire to explore the relatively new area of step-growth photopolymerization for its own sake;
- (ii) the possibility of preparing novel polymeric structures which might have interesting physical or chemical properties.

The original objective was to attempt establishing the range of applicability of the polymer syntheses formulated in Figure 1.10.⁴⁶

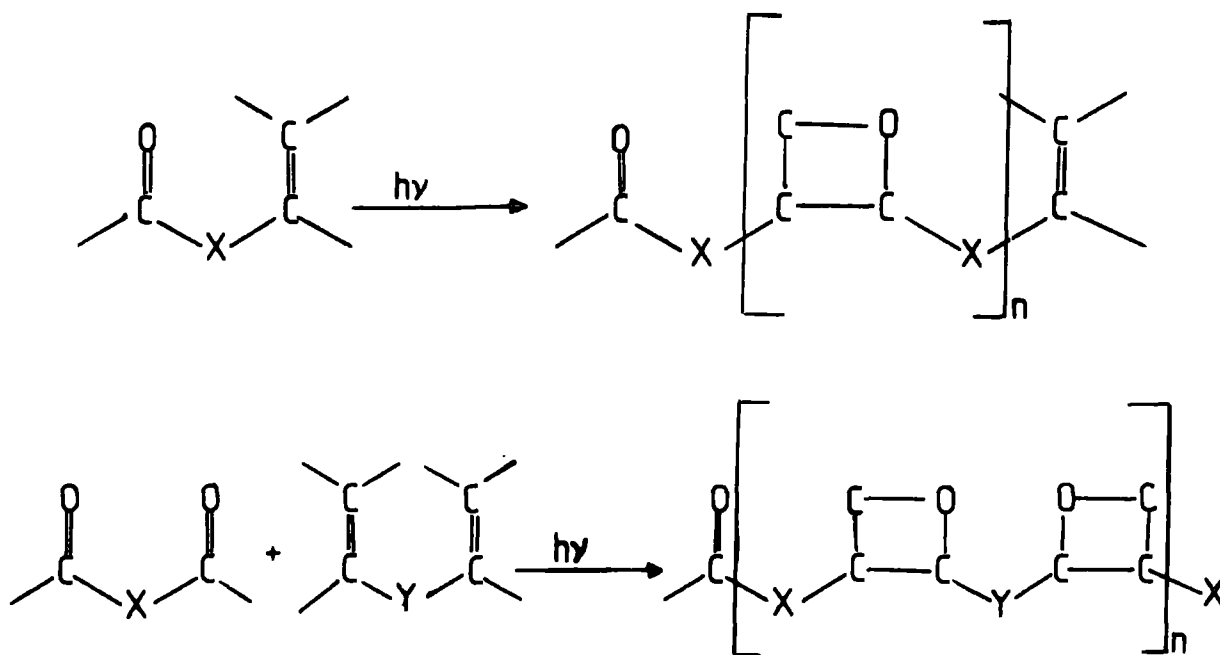


Figure 1.10

It was intended that X and Y would be either fluorine or highly fluorinated groups but in principle a wide variety of structures could be used. The experimental work carried out on this initial project involved the study of a model reaction between a perfluorodicarbonyl compound (namely hexafluoro-glutaryl fluoride) and two different perfluoromonoolefins (namely perfluorohept-

1-ene and perfluorocyclohexene). The aim was to determine the conditions under which the model reaction could give a high yield of 1:1 or 2:1 adducts, and then to attempt the actual polymer forming reaction (diacid fluoride in the presence of a diolefin) under the appropriate conditions (Figure 1.11).

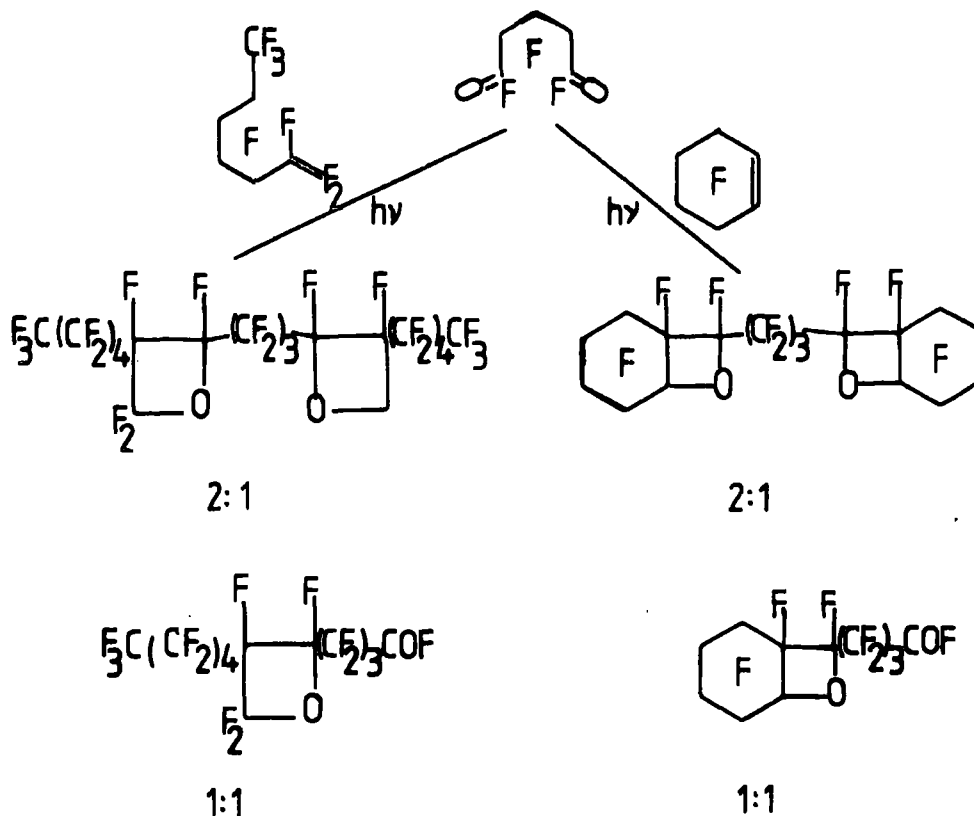


Figure 1.11

This work was largely unsuccessful and the results obtained will be discussed in Chapter 4 of this thesis.

The main body of work to be described is concerned with an examination of some aspects of the photopolymerization of aromatic carbonyl compounds. As a first aim the photochemistry of tere- and iso-phthalaldehyde was examined both in the solid state and in the presence of hydrogen donors. No reaction was detected in the first case, whereas the latter experiments afforded insoluble branched materials of as yet unidentified structures. Irradiation of the mono-

functional compound, benzaldehyde, either neat or in the presence of hydrobenzoin yielded a telomer with interesting physical properties. Attempts to characterize this material will be described in Chapter 3.

Further attempts to extend the well known photochemical synthesis of polybenzopinacols⁴⁰ to polymers with more than two adjacent C_6H_5-C-OH units in the repeating block (polypentaphenylglycerols and higher analogues) (Figure 1.12) did not give positive results. Model monomer reactions were attempted for this purpose and, as a result, interesting properties of certain aromatic alcohols were established.

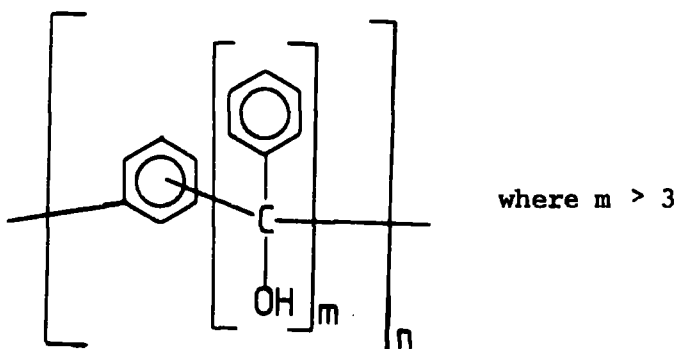


Figure 1.12

Finally, extension to polymer synthesis of a well established reaction, namely the photoreductive coupling of the benzophenone-diphenylmethane system, afforded polymeric materials of relatively low d.p. Spectroscopic and chemical evidence and especially the use of comparative ¹³C nmr studies have been successfully employed for the assignment of product structures. A detailed account of this work appears in Chapter 2. Most of the chemistry involved in these studies is based on aspects of the photochemistry of the carbonyl group.

1.7. Brief Introduction into the Photochemistry of Carbonyl Compounds.

The absorption of light in non-conjugated organic molecules usually involves the promotion of a single electron from a σ , π or n orbital in the ground state to a previously vacant π^* or σ^* antibonding orbital. Molecular

orbitals, appropriate energy levels and electronic transitions for the simplest example of a molecule containing the carbonyl chromophore, formaldehyde, are available.⁴⁷ With simple ketones, the transition of lowest energy is the weak $n \rightarrow \pi^*$ transition generally responsible for the longest wavelength (ca. 290 nm) absorption and fundamental in most photochemical processes involving saturated ketone photolysis. A very intense absorption around 150 nm corresponds to a $\pi \rightarrow \pi^*$ excitation.

Conjugation shifts both the $n \rightarrow \pi^*$ and $\pi \rightarrow \pi^*$ absorption bands to longer wavelengths. The lone pair orbitals are relatively unaffected whilst the highest π orbital in the ground state is raised in energy, relative to a non-conjugated carbonyl π orbital, and the lowest π^* orbital lowered in energy. In appropriately substituted unsaturated ketones the π, π^* configuration may become the lowest triplet state, the $\pi \rightarrow \pi^*$ shift being large compared to the $n \rightarrow \pi^*$ shift.⁴⁷

Most of the carbonyl photochemistry occurs via the triplet excited manifold, indeed via the n, π^* triplet, which results from the transition of one electron from the oxygen n orbital to the π^* orbital, followed by a spin flip (intersystem crossing). A common picture of the carbonyl n, π^* triplet is shown in Figure 1.13.

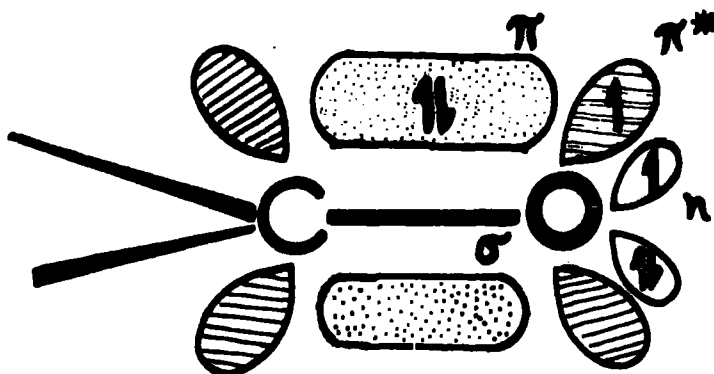


Figure 1.13

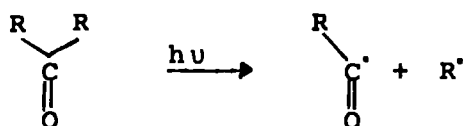
For most carbonyl compounds intersystem crossing from the excited singlet to the triplet state is a very efficient process.²⁹ The quantum yield for

intersystem crossing of benzophenone is 1.00. With some carbonyl compounds however, the relative energies of the excited states may be unfavourable for intersystem crossing. For example 2-naphthaldehyde, 9-anthraldehyde and 9-tetracenealdehyde all fluoresce on irradiation in ethanol⁴⁸ indicating inefficient intersystem crossing. In non-polar solvents the $n \rightarrow \pi^*$ transition is shifted to longer wavelengths and the $\pi \rightarrow \pi^*$ transition to shorter wavelengths, and in heptane solvent 2-naphthaldehyde and similar aromatic aldehydes become non-fluorescent with efficient intersystem crossing.

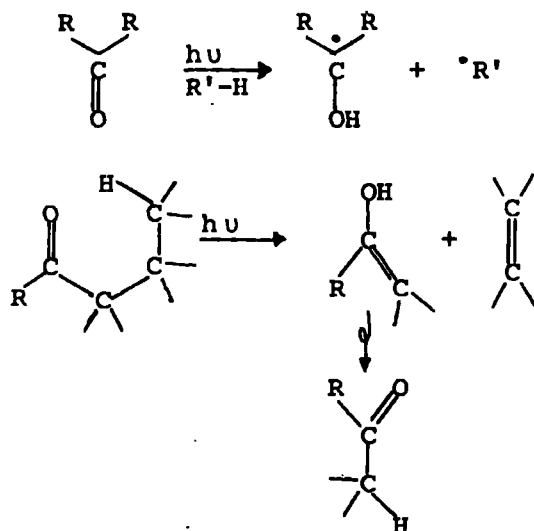
The commonly accepted picture of the n, π^* excited state of carbonyl compounds, involving promotion of an 'n' electron to an antibonding π^* orbital, results in a lone electron localized on the oxygen.²⁹ The state is thus formally analogous to an ordinary alkoxy radical. This analogy extends to observed reactions; thus, alkoxy radicals are known to abstract hydrogen and add to olefins, reactions which find their counterparts in photoreduction and photocycloaddition reactions of carbonyl compounds.^{29,49,50}

The majority of known photochemical reactions of alkanones have been classified under one of three reaction types:⁵¹

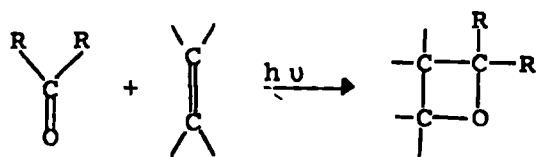
(i) cleavage of the bond to the carbonyl group - Norrish type I cleavage:



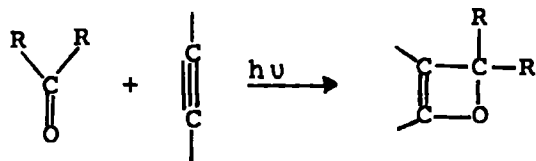
(ii) intramolecular (Norrish type II) or intermolecular abstraction of a hydrogen atom by the carbonyl oxygen atom:



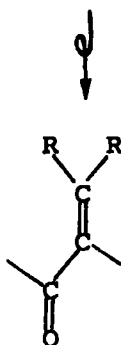
(iii) cycloaddition to an unsaturated carbon-carbon linkage:



An oxetane



An oxetene
(unstable)



An α,β -unsaturated
compound

Aldehydes and aromatic ketones undergo related reactions and unsaturated carbonyl compounds (conjugated and non-conjugated) undergo a wide variety of cleavage, abstraction, rearrangement and cycloaddition reactions. The varying reactions are discussed in standard texts,^{52,53,54} and topics specifically relating to carbonyl compound photochemistry may be found in reviews such as those by Swenton and Turro et al.⁵⁵

The types of reaction directly relevant to these studies are type 2 intermolecular (photoreduction of carbonyl) and type 3 (oxetane and poly-oxetane formation). They will be discussed in more detail in the appropriate chapters.

CHAPTER 2

Photoreductive polymerization of aromatic diketones

2.1. Introduction

2.1.a. Historical background

The photoreductive coupling of benzophenone in ethanol⁵⁶ or isopropanol⁵⁷ is a well established reaction (Figure 2.1). Reaction occurs by n,π^*

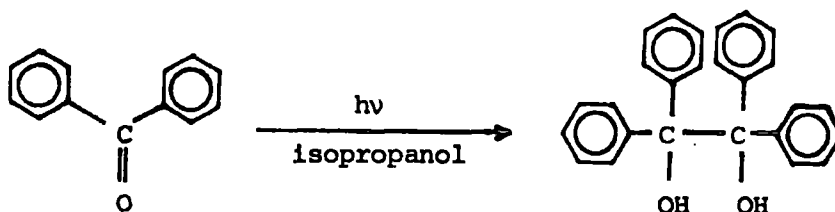


Figure 2.1

excitation of benzophenone carbonyl followed by reduction and coupling of the resultant ketyl radicals. With benzophenone and isopropanol the yield has been reported to be quantitative⁵⁸ and the reactions shown in Figure 2.2 have

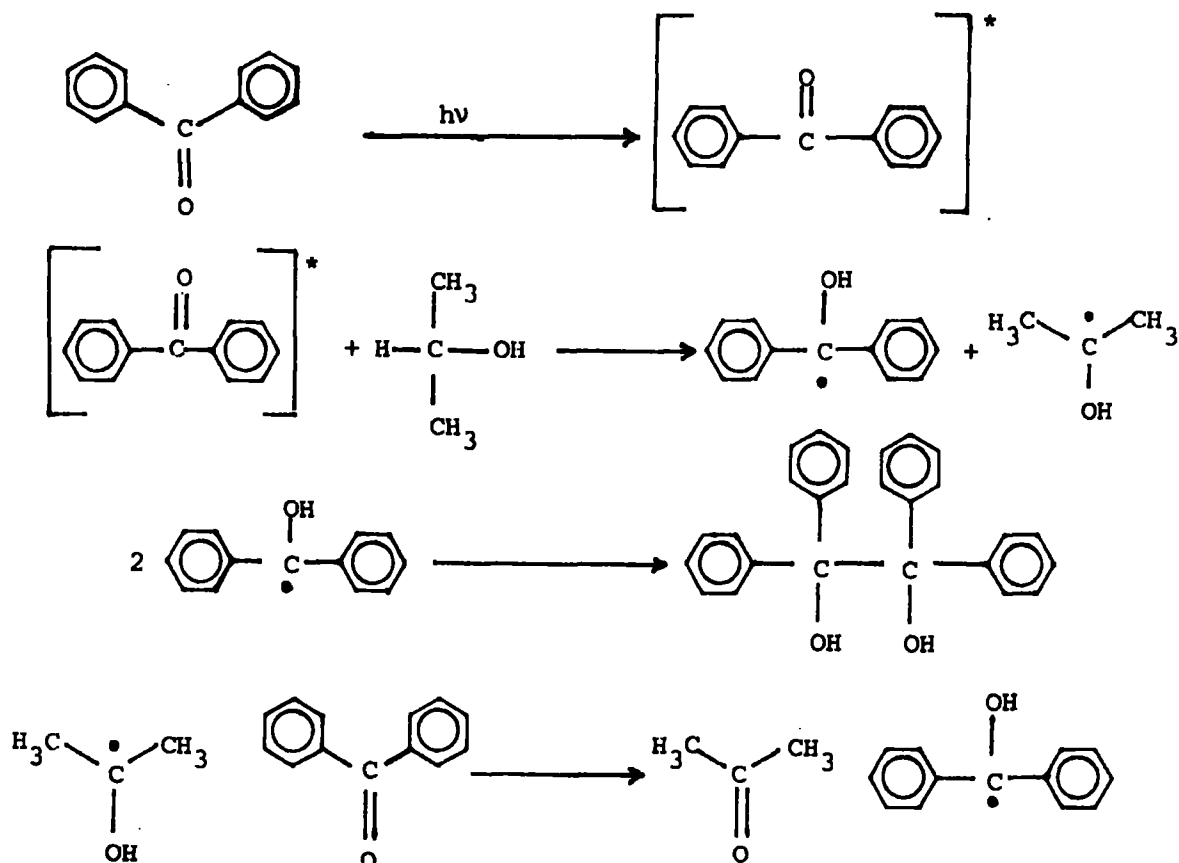


Figure 2.2

been used to account for the observed process. A more detailed discussion of this photoreduction will be given in 2.1.b.

At the beginning of this decade the reaction was applied to the synthesis of polybenzopinacols from benzophenone-type aromatic diketones, according to the scheme shown in Figure 2.3.⁵⁹⁻⁶² The first results were published by Higgins and co-workers in 1970;⁶⁰ they attempted the photoreductive polymerization

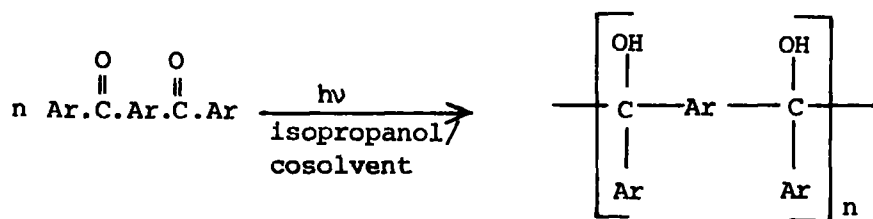


Figure 2.3


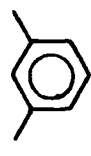

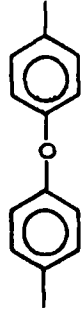
of m- and p-dibenzoylbenzene and 4,4'-dibenzoyldiphenylether (preparative method A, Table 2.1). In the same issue of the same journal Pearson and Thiemann⁵⁹ described a similar investigation of p-dibenzoylbenzene (preparative methods D-F, Table 2.1). Both groups obtained only low molecular weight oligomers. Modifications introduced by Higgins' group (preparative methods B,C) using an open system under a stream of nitrogen rather than a closed vessel under a nitrogen atmosphere and shorter irradiation times gave a significantly higher molecular weight polymer from 4,4'-dibenzoyldiphenylether. Polymers from 4,4'-dibenzoyldiphenylsulphide, 4,4'-dibenzoyldiphenyl-methane and -ethane were also obtained by the modified procedures B,C, but m- and p-dibenzoylbenzene and 4,4'-dibenzoyldiphenyl failed to give polymers.

Higgins claimed that use of a 450 watt lamp with Pyrex filter instead of a 100 watt long wavelength lamp allowed much shorter irradiation times but produced polymers of lower inherent viscosity.⁶¹ He suggested that the lower molecular weight polymers may have been a result of cleavage of C-C bonds by

Table 2.1

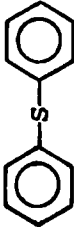
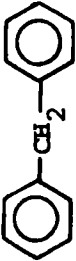
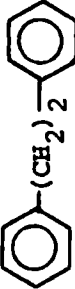
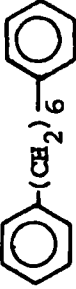
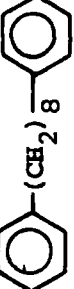
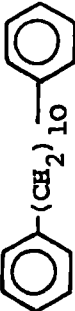
Earliest attempts to effect the photoreductive polymerization of aromatic diketones



Monomer	Polymerization		Polymer Properties				Reference
	Preparative Method	Yield (%)	\bar{M}_n	d.p.	Inherent viscosity η	Solvent	
	A	94	435	2	0.06 ^a	Benzene	60
	B,C	-	1,570	NO POLYMER			61
	D E F	-	698	CYCLIC PRODUCT			59
	A	94	825	3	0.12 ^a	Benzene	60
	B,C	-	-	NO POLYMER			61
	B,C	-	NO POLYMER				61
	A	92	805	3	0.14 ^a	Benzene	60
	B	~ 100	-	-	0.30	Dioxane	61
	C	78	-	-	0.26	Dioxane	61

contd./

Table 2.1 contd.

Monomer	Polymerization		Polymer Properties				Reference
	Preparative Method	Yield (%)	\bar{M}_n	d.p.	Inherent viscosity η	Solvent	
Ar							
	B C	~ 100 60			0.10 0.04	Dioxane Dioxane	61 61
	B C G	~ 100 76		70	0.25 ^b 0.21 ^b	Dioxane Dioxane	61 61 62
	B C	~ 100 68			0.45 ^b 0.37 ^b	Dioxane Dioxane	61 61
	G		13,000	32	0.26 ^c	DMF	62
	G		11,000	23			62
	G		16,000	35	0.32 ^c	DMF	62

/contd.

Table 2.1 contd.

- A. 5 g. diketone dissolved in 125 ml. benzene + 125 ml. isopropanol and 1 drop acetic acid added. Solution deoxygenated (N_2 at reflux) and irradiated (Fisher Blak-Ray long wavelength UV lamp) for 1 week in stoppered flask. Solvent removed, polymer washed and then dried at 62° under vacuum.
- B. 6 g. diketone dissolved in 200 ml. 1:1 benzene/isopropanol and 2 drops glacial acetic acid added. Solution purged with N_2 at reflux and irradiated (100-W Blak-Ray B100-A long wavelength lamp) at reflux under slow stream of N_2 for 24 hours. Solvent removed, polymer washed and then dried in vacuo at 80° .
- C. 5 g. diketone dissolved in 250 ml. 1:1 benzene/isopropanol and then treated essentially as in B except that irradiation was for only 14-2 hours with Ace Glass No. 3515 450-W lamp fitted with Pyrex filter.
- D. 2.334 g. polymer dissolved in 150 ml. benzene + 50 ml. isopropanol and irradiated for 19 hours. Solution was contained in Pyrex apparatus, stirred by magnetic bar and protected from air by argon atmosphere. Irradiation was with mercury high-pressure lamp, Philips HPK 125W, suspended in an open well surrounded by water cooled jacket. After irradiation, solution was concentrated and product dissolved in acetone, filtered, acetone evaporated and resulting solid dried in vacuo at 80° and then 120° .
- E. Solutions were irradiated in series of 3 ml. ampoules. Ampoules were filled, flushed with argon, sealed and mounted against outer wall of water jacket of irradiation apparatus described in D. During irradiation (25 hours) water was allowed to boil gently from heat generated by lamp. After irradiation, contents of several ampoules were combined and evaporated to dryness.
- F. Ampoules were filled with solution to be irradiated, degassed, sealed and mounted on a plastic board and immersed in water bath at 25° . Plastic board was 15" from an immersed Sylvania 400-W, H33-ICD medium pressure lamp.
- G. 0.06M solutions of monomer in 1:2 isopropanol/dichloromethane mixture were degassed and irradiated at 350 nm for ca. 7 hours. Solvent was then evaporated and the residual yellow powder dissolved in DMSO ($\sim 10\%$ insoluble) and precipitated by addition of DMSO solution to methanol.

Notes

- a) 0.25 g. polymer/100 ml. benzene. b) Inherent viscosity. c) Intrinsic viscosity.

the higher intensity irradiation;⁶¹ this seems unlikely and a more plausible explanation may lie in the greater heat output of the 450 watt lamp. The reported failure of m- and p-dibenzoylbenzenes and 4,4'-dibenzoyldiphenyl to form high polymers was attributed⁶¹ to a bathochromic shift of the $\pi \rightarrow \pi^*$ absorption in going from benzophenone to these diketones, resulting in overlap with the $n \rightarrow \pi^*$ absorptions and lack of efficient hydrogen abstraction from the low-lying π, π^* triplet. Although later work validates this explanation in the case of 4,4'-dibenzoyldiphenyl it seems less plausible for the other monomers.²⁶ The higher molecular weight polymers produced by Higgins' group, showed no carbonyl absorptions (ca. 1650 cm^{-1}) in their infrared spectra but low molecular weight polypinacols showed considerable residual carbonyl stretch, which was attributed⁶⁰ to unreacted monomer or to such structures as the one shown in Figure 2.4. Strong bands around 3500 cm^{-1} were characteristic of the tertiary

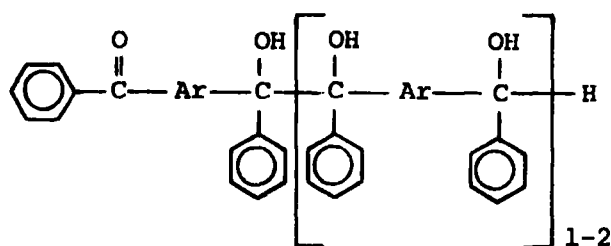


Figure 2.4

-OH groups in the polypinacols. The infrared spectra of the polymers were compared with those of model pinacols obtained by photocoupling p-benzoyldiphenylether and p-benzoyldiphenylethane, and by coupling p-benzoyldiphenylmethane with magnesium and iodine. Infrared spectra of the model pinacols and the polymers were qualitatively similar. Likewise, infrared spectra of oligomers from m- and p-dibenzoylbenzene were qualitatively similar to the infrared spectrum of benzopinacol.

N.m.r. spectra of the oligomers from m- and p-dibenzoylbenzenes and 4,4'-dibenzoyldiphenylether⁶⁰ showed a small peak at δ 5.3 assigned to

benzhydryl protons; the higher molecular weight samples showed no benzhydryl hydrogen in their n.m.r. spectra. Higgins⁶¹ has suggested that in preparative methods B,C this may be a result of increased monomer concentration compared to method A, and that weaker reducing solvents may also yield higher molecular weight polymer.⁶⁰

Pearson and Thiemann studied the irradiation of p-dibenzoylbenzene in isopropanol in some detail.⁵⁹ Under 'normal' irradiation conditions (preparative method D, Table 2.1) a polymer comprising ca. 5 coupled monomer units was obtained. The n.m.r. spectrum of this polymer was assigned as follows: δ 1.3 (singlet CH_3), δ 2.4 (broad singlet OH), δ 3.0 (broad singlet OH), δ 5.8 (very weak benzhydryl hydrogen), δ 7.8 (multiplet, aromatic hydrogens). The intensity of the signal at δ 5.8 indicated that at least half the polymer ends were capped with benzhydryl hydrogen (Figure 2.5, X = H)

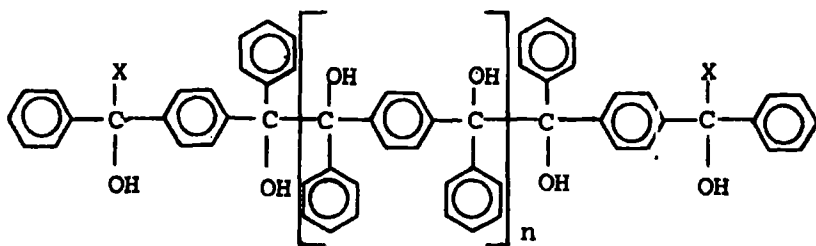


Figure 2.5

The relative intensities of the signals at δ 5.8 and δ 1.3 suggested that a few polymer chains terminated with isopropylalcohol groups (Figure 2.5, X = $(\text{CH}_3)_2\text{COH}$) whilst the remainder of the polymer was designated to be in cyclic form. When the reaction was carried out at a higher temperature (100° preparative method E, Table 2.1) the product obtained was said to be capped almost exclusively with hydrogen, the n.m.r. signal at δ 5.8 being much stronger, whereas the product obtained at 25° (preparative method F, Table 2.1) was assigned a cyclic structure since only aromatic (δ 7-7.5) and OH (δ 3.0) proton

n.m.r. signals were observed. In these cases infrared spectra of the products from p-dibenzoylbenzene showed the absence of carbonyl groups.⁵⁹

Elemental analyses of polypinacols, where reported,⁵⁹⁻⁶¹ were sometimes in only fair agreement with the calculated values.

During irradiations of m- and p-dibenzoylbenzenes⁵⁹ a yellow colour has been observed. Pearson⁵⁹ has suggested that this is due to the intermediate shown in Figure 2.6 (in the case of p-dibenzoylbenzene), the evidence on which this assignment was based being a long wavelength absorption at 416.4 nm, the

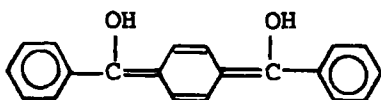


Figure 2.6

non-radical nature of the intermediate (which showed no e.s.r. signals) and its stability. However m-dibenzoylbenzene could not form an analogous quinone-dimethide structure, which casts doubt on this rationalization.

De Schryver and co-workers⁶² reported that significantly higher molecular weight polybenzopinacols could be obtained by irradiation of degassed isopropanol-dichloromethane solutions of bisbenzophenone at 350 nm (preparative method G, Table 2.1). No benzhydryl hydrogen signal appeared in the n.m.r. spectra of the products,⁶² d.p.'s ranging from 23 to 70.

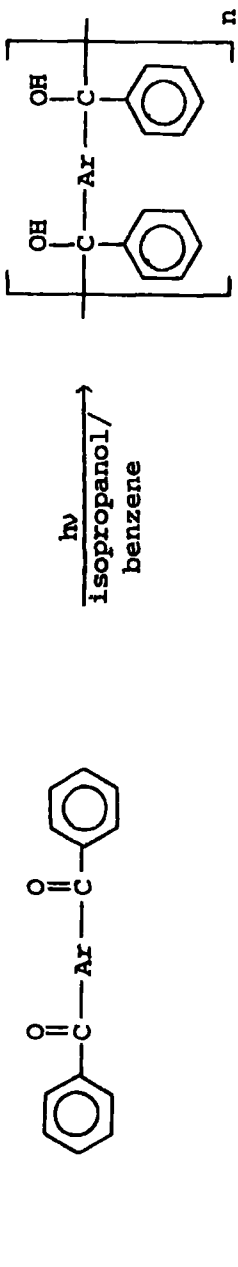
The results of the work reviewed above are summarised in Table 2.1.

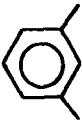

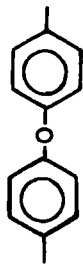
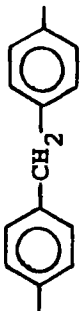
The effect of solvent composition on the reaction was examined by various workers.^{60,61,62} De Schryver reported that the rate of disappearance of the carbonyl functionality depends on the nature of the cosolvent;⁶² for 0.05M solutions of 4,4'-dibenzoyldiphenylmethane at 32°C, relative rates for a 1:5 molar ratio of isopropanol:- cosolvent were, CHCl₃ 1, C₆H₅CH₃ 2.5 and benzene 4.

Higgins claimed that a 50:50 mixture was most satisfactory for the benzene-isopropanol solvent system, arguing that increasing the proportion of isopropanol reduced monomer solubility whilst decreasing the proportion of isopropanol necessitated longer irradiation times.⁶¹ He reported that for polypinacols prepared by method A (Table 2.1) it made no detectable difference whether the solvent was neat isopropanol or 50:50 mixtures of THF and isopropanol, or benzene and ethanol, or benzene and isopropanol;⁶⁰ these results are surprising in the light of the work reported by the Belgian group.

As can be seen from the above review of the early publications in this field there was some confusion and disagreement between the various groups. Work carried out in this department⁶⁴ was relevant in resolving some of the ambiguities. The essential features of this work are summarized in Table 2.2. Aromatic diketones were prepared by Friedel-Crafts synthesis and rigorously purified. Monomers were dissolved in mixtures of isopropanol and benzene and oxygen was excluded from the solutions by bubbling nitrogen through for about 30 mins. Irradiations were carried out using a Rayonet photochemical reactor incorporating RUL-3500 lamps which emit between 3200Å and 4000Å with the greatest intensity at 3660Å. This work was carried out solely to check the photoreactivity of the monomers and consequently a detailed optimization of conditions was not undertaken, however a number of useful points emerge from a consideration of the data presented in Table 2.2. Considering the reactions carried out using 1:1 benzene-isopropanol mixtures, it is clear that in several cases significantly higher d.p.'s were obtained by Andrews than those previously reported; for example, in the case of m-dibenzoylbenzene an improvement from d.p. 3 to d.p. 17 was observed. Since these reactions were carried out under apparently identical conditions the most likely cause of the observed difference must be the purities of monomer and/or solvents and the explanation advanced previously for the lack of reactivity of

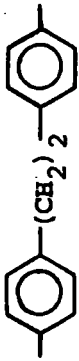
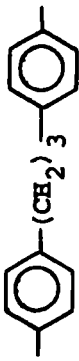

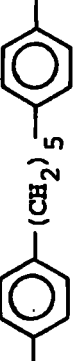


Table 2.2
 Re-examination of the photoreduction of aromatic diketones conducted by Andrews. 64



Ar	Polypinacol Code	Irradiation in 1:1 benzene:isopropanol		Irradiation in 3 to 4:1 benzene:isopropanol	
		\bar{M}_n	(d.p.)	\bar{M}_n	(d.p.)
	M	4800	(17)		
	P	1300	(5)		
	E	3400	(9)		
	L	950	(3)	14700	(39)

contd./

Table 2.2 contd.

Ar	Polypinacol Code	Irradiation in 1:1 benzene:isopropanol		Irradiation in 3 to 4:1 benzene:isopropanol	
		\bar{M}_n	(d.p.)	\bar{M}_n	(d.p.)
	2	2700	(7)	3700	(9)
	3	2300	(6)	4400	(11)
	4	3500	(8)		
	5	9100	(21)	7900	(18)
	6	10300	(23)		
	10	12600	(25)		

m-dibenzoylbenzene (namely, a bathochromic shift of the $\pi \rightarrow \pi^*$ absorption and inefficient hydrogen abstraction by the low-lying π, π^* triplet) must be invalid. This interpretation is confirmed by consideration of the ultraviolet spectra of aromatic diketones shown in Figure 2.7.⁶⁵

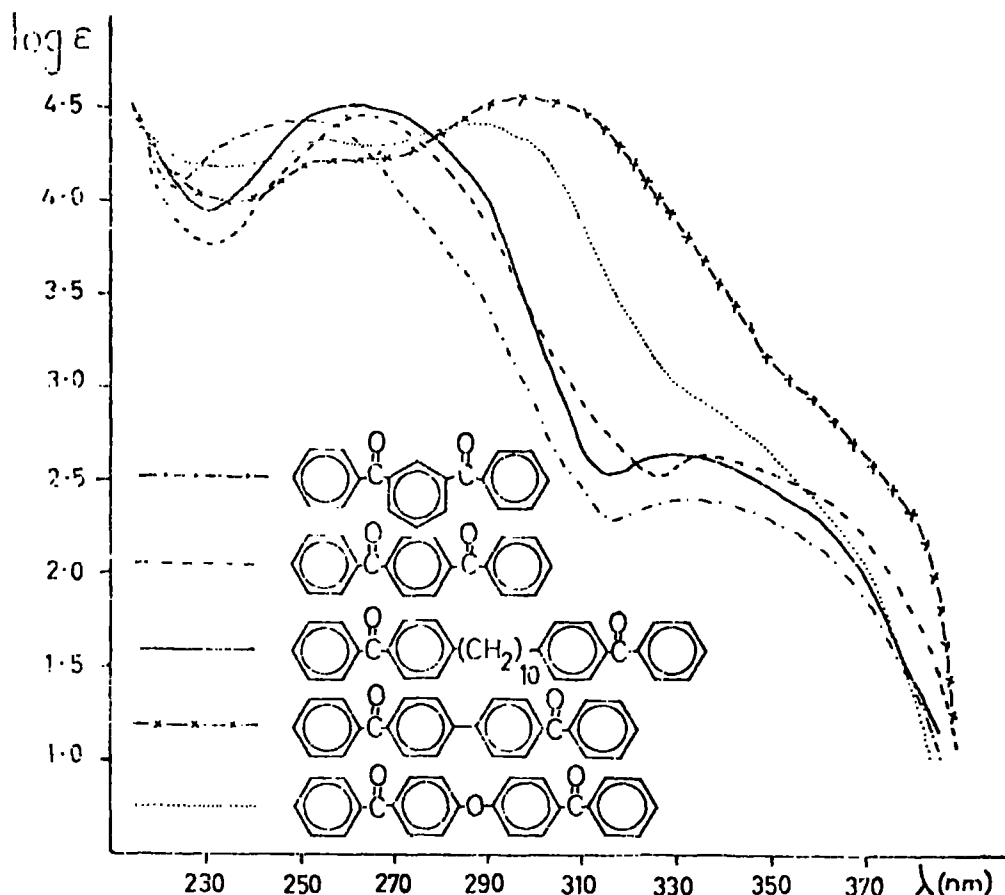


Figure 2.7

For the majority of diketones examined by Andrews the polypinacols precipitated from solution when a 1:1 benzene-isopropanol mixture was used whereas when a higher proportion of benzene was used the polymers remained in solution and consequently a higher d.p. was generally attained.

The best results in this field have been achieved however by De Schryver and co-workers⁴⁰ who adopted a new approach to the subject. They considered how the photoreductive coupling of diaryl ketones was influenced by the detailed mechanism for the photoreduction of benzophenone put forward by

Weiner in 1971.⁶⁶ The cage reaction reported by Weiner, that is the combination of a $(C_6H_5)_2\dot{C}OH$ and a $(CH_3)_2\dot{C}OH$ radical to give the mixed pinacol of structure $(C_6H_5)_2C(OH)C(OH)(CH_3)_2$, constitutes a chain terminating step in this context. Such a complication could be eliminated if a bisbenzhydrol (Figure 2.8) was used as both a hydrogen donor and a monomer in the polymerization, one would then

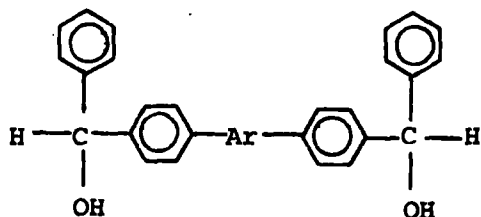


Figure 2.8

expect higher molecular weight polymers to be obtained. Further this approach allows the preparation of alternating copolymers or homopolymers by choice of appropriate monomer pairs whereas one would expect that the irradiation of a binary mixture of diketones in the presence of isopropanol would lead to statistical copolypinacols.⁴⁰ De Schryver and co-workers prepared a number of aromatic diketones and diketotriazoles by well established routes. Reduction of some of the diketones afforded the corresponding bisbenzhydrols. Irradiation of equimolar solutions (benzene solvent) of diketones/bisbenzhydrols at 350 nm yielded as expected high molecular weight polypinacols. Before irradiation, oxygen was excluded from the solutions by degassing on a vacuum line. Results are summarized in Table 2.3. It can be seen that the diketone/bisbenzhydrol system provides the most valuable method for obtaining good yields of high molecular weight materials. In some cases d.p.'s as high as 430 were obtained.

On the other hand, the photolysis of some binary mixtures of aromatic diketones in the presence of isopropanol yielded statistical copolypinacols. In some favourable cases, the n.m.r. spectrum of the copolymers obtained

Table 2.3⁴⁰

Photopolymerization of Bisarylketone - Bisbenzhydrol System



Ketone Ar	Hydrol Ar'	Concentration (mole/litre ^a)	Irradiation time	$\frac{M}{n}$ ^b	d.p.	$[\eta]$
A	A	0.300	4 days	174,000	430	0.36
1	1	0.170	5 days	-----	---	0.18
A	10	0.013	4 days	93,000	102	0.33
A	E	0.170	5 days	-----	---	0.21
A	P	0.100	4 days	-----	---	0.08
K5	A	0.170	4 hrs	141,000	362	0.43
K6	A	0.170	5 hrs	140,000	354	0.43

Footnotes: a: combined ketone/hydrol concentration

b: measured on the high molecular weight fraction obtained by precipitation

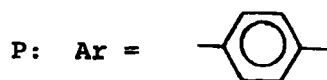
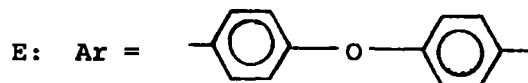
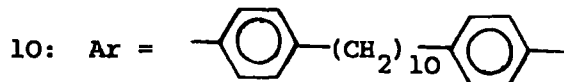
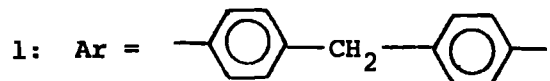
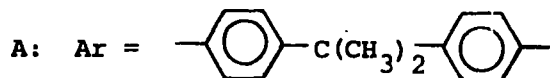
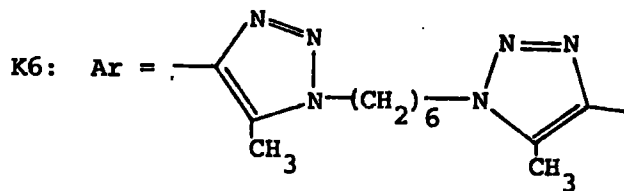
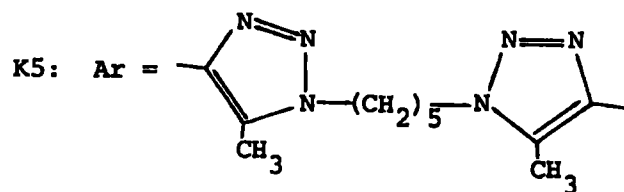


Table 2.3 contd.



showed three distinct linkages and from the infrared spectrum intensities the copolymer's composition and the number average length of the sequences could be determined. De Schryver's work provided two very important conclusions:

- i) the photopolymerization of bisarylketones is highly affected by every aspect of the photoreduction of the model ketones,
- ii) the bisarylketone/bisbenzhydrol system provides a means of overcoming the 'cage' reaction which is a chain terminating reaction; it is clearly the best method for the synthesis of high molecular weight polypinacols.

2.1.b. Some aspects of relevant photochemistry

2.1.b.1. Introductory survey

The photoreduction of carbonyl compounds in suitable hydrogen donating solvents has been widely investigated for well over half a century⁶⁷ since Ciamician and Silber began research in the field.⁵⁶ Photoreductive coupling has already been discussed briefly in 2.1.a with reference to the preparation of polybenzopinacols and a simple mechanism for the photoreduction of benzophenone in isopropanol was given (see Figure 2.2).

In the presence of alkali, however, it was discovered that benzhydrol was formed,⁶⁸ and in a series of photoreductions of benzophenone and substituted benzophenones containing a small amount of sodium-2-propanolate, Bachmann⁶⁸ showed that benzhydrols could be obtained in high yield. He proposed that as fast as the pinacol was formed it decomposed to benzhydrol (in the case of benzopinacol). However, the proposed mechanisms for the formation of benzhydrol from benzophenone have subsequently been questioned.⁶⁹

The most intensively studied reaction is the actual photoreductive coupling reaction yielding 1,2-ethane diols. Aldehydes and ketones undergo the reaction,⁶⁷ ketones having received by far the most attention. Some examples of ketones that yield pinacols on a preparative scale include, apart from benzophenone,

4,4'-dimethoxybenzophenone,⁷⁰ 4,4'-dichlorobenzophenone,⁷⁰ 3-benzoylpyridine,⁷¹ acetophenone,⁷² 2-, 3-, and 4-acetylpyridines,⁷³ and α -tetralone.⁷⁴

Benzophenone is the most thoroughly studied ketone, yielding benzopinacol in quantitative yield. The quantum yield for the formation of acetone in the photoreduction of benzophenone in isopropanol is nearly constant using irradiation at several different wavelengths between 366 and 254 nm,⁷⁵ suggesting that both $n \rightarrow \pi^*$ excitation and $\pi \rightarrow \pi^*$ excitation (of the benzene chromophore) may ultimately bring about reaction.²⁹

Various solvents have been used as hydrogen donors, in particular alcohols and alkylbenzenes.^{76,77} Many comparisons of solvents have been made with benzophenone as reacting ketone. Some quantum yields of benzophenone disappearance in various solvents are shown in Table 2.4.⁷⁸

Table 2.4

Quantum Yields of Benzophenone Disappearance in Hydrogen Donor Solvents

Solvent	Molar Concentration of Benzophenone	Quantum Yield of Disappearance
Water	10^{-4}	0.02
Benzene	10^{-2}	0.05
Toluene	10^{-2}	0.45
Hexane	$10^{-2} - 10^{-4}$	1.00
Ethanol	$10^{-4} - 10^{-1}$	1.00
Isopropanol	$10^{-5} - 10^{-1}$	0.80 to 2.00

Where the quantum yields of benzophenone disappearance are almost zero (water and benzene), bond energies with respect to hydrogen abstraction are high enough ($> 100 \text{ kcal mole}^{-1}$) to prevent hydrogen atom abstraction by the triplet with anything other than very low collisional efficiency.⁷⁷ In

hexane, toluene and ethanol, quantum yields are less than or equal to unity and concentration independent.⁷⁷ It is suggested that all benzophenone triplets abstract a hydrogen atom, the appropriate C-H bond energies in hexane and toluene being approximately 85 and 80 kcal mole⁻¹ respectively. The overall quantum yields then depend on the thermal reactions of the radical R[•] formed on abstraction from the solvent RH. Reversion of the primary hydrogen abstraction reaction (i.e. Ph₂C[•]OH + R[•] → Ph₂CO + RH) results in an overall quantum yield of less than unity. In isopropanol where quantum yields tend to a limiting value of 2, R[•] [i.e. (CH₃)₂C[•]OH] transfers hydrogen to benzophenone with the production of acetone and more Ph₂C[•]OH. Such a transfer is energetically improbable in the benzyl or hexyl radicals from toluene or hexane. Where ketones are not photoreduced in alcoholic solvents, a more powerful hydrogen donor such as tri-n-butylstannane may allow photoreduction, as in the case of 2-acetonaphthone.⁷⁹

A recurring problem⁶⁶ in mechanistic studies of benzophenone photoreduction in isopropanol was the failure to detect the mixed pinacol 2-methyl-1,1-diphenyl-1,2-propanediol (Figure 2.9), whereas analogous cross-coupled products were obtained for benzophenone photoreduction in toluene and cumene,⁷⁶

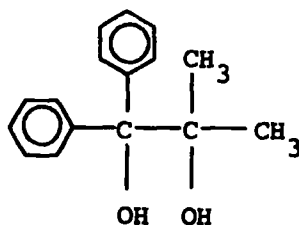


Figure 2.9

and primary alcohol solutions.⁸⁰ Weiner has shown that this mixed pinacol is in fact produced in the photoreduction of benzophenone in isopropanol, and under conditions where all free ketyl radicals are scavenged.⁶⁶ Thus, the mixed pinacol results from a cage reaction and the overall reaction is explained

by the modified sequence shown in Figure 2.10. The significant fraction of cage reaction (O.11) requires that, in the pair of radicals comprising A (where

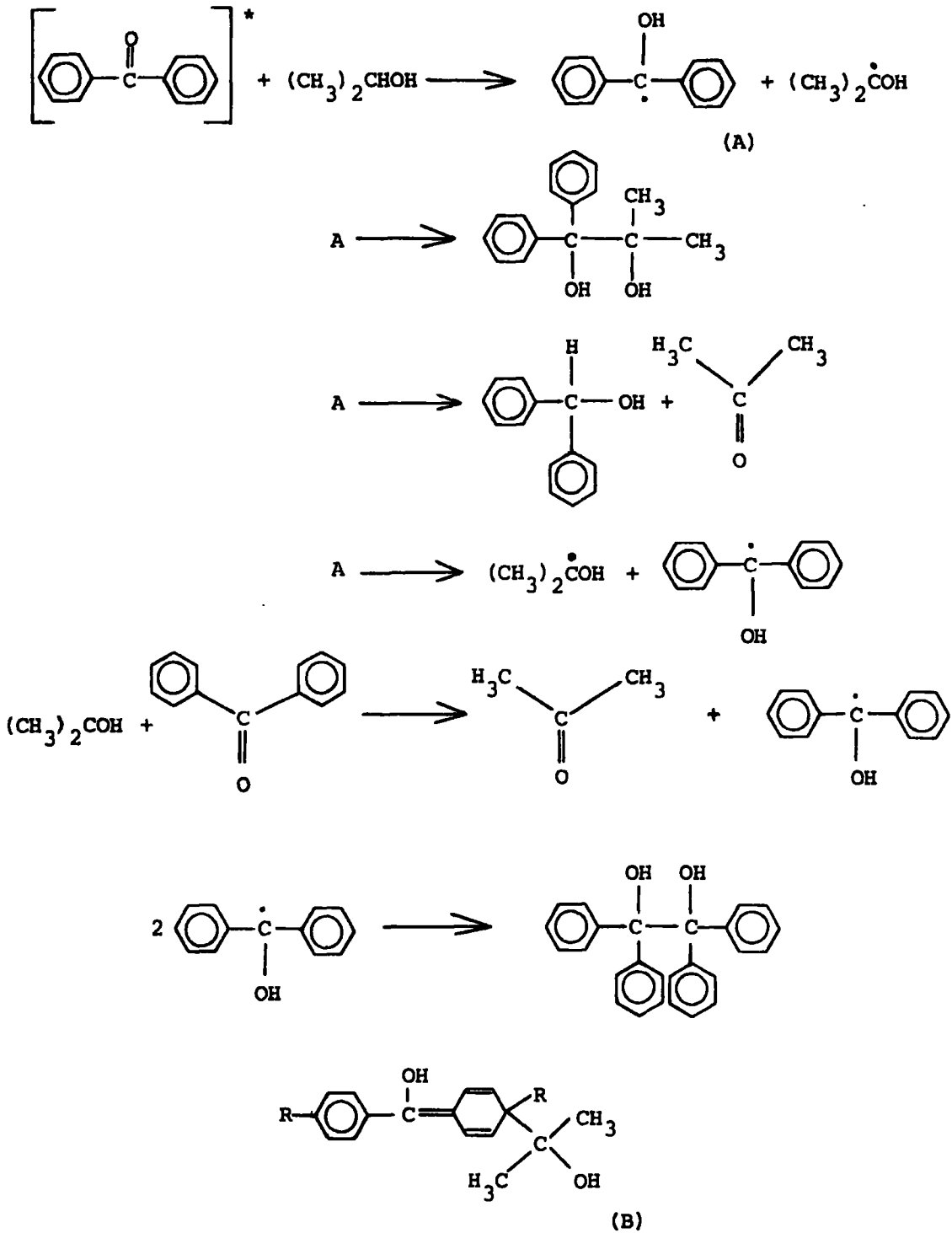


Figure 2.10

the electron spins are initially parallel), spin flipping must occur in some radical pairs prior to diffusion out of the solvent cage. It must be noted that there has been much controversy over the nature of intermediates in the photoreduction of benzophenones in isopropanol.⁸¹ Filipescu^{81,82} has proposed that the observed yellow intermediate has the structure B (shown in Figure 2.10) in the case of benzophenone and 4-alkyl substituted benzophenone photoreductions in isopropanol. For benzophenone, Filipescu⁸¹ suggested a reaction scheme shown in Figure 2.11.

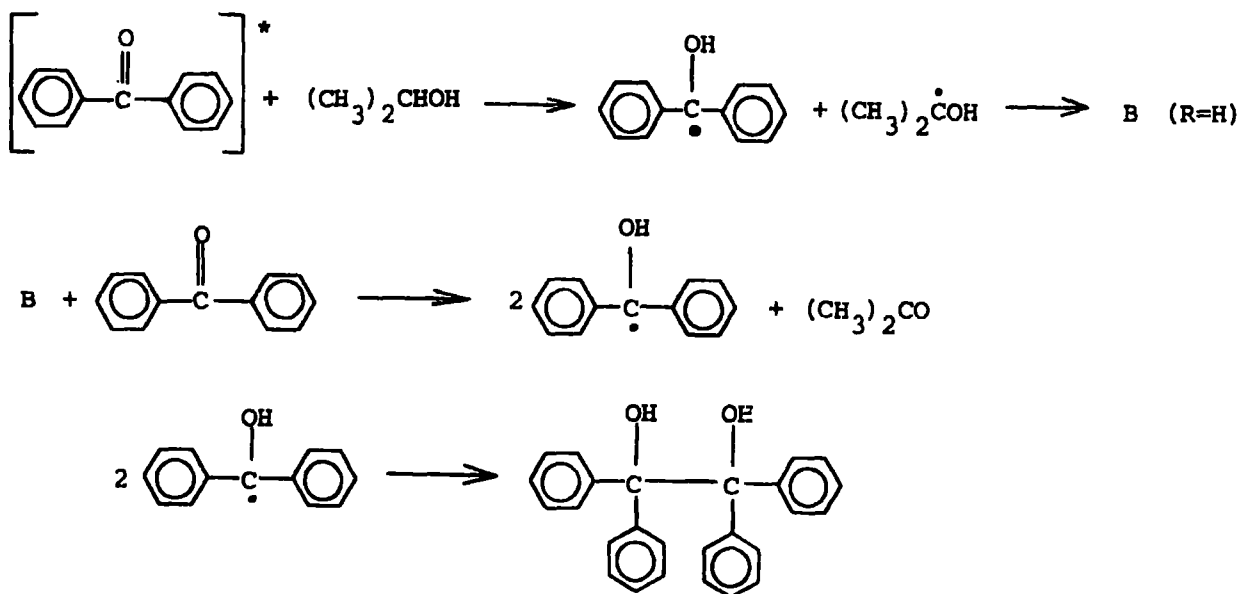


Figure 2.11

It was proposed that B yielded products via the dark reaction shown in Figure 2.12. However, Weiner⁶⁶ stated that the quantitative formation

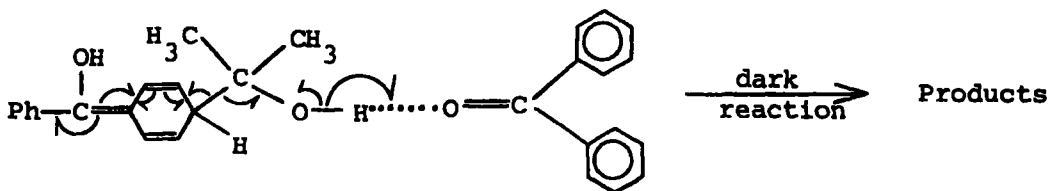


Figure 2.12

of B from the pair $\text{Ph}_2\dot{\text{C}}(\text{OH}) + (\text{CH}_3)_2\dot{\text{C}}\text{OH}$ is inconsistent with the detection of the mixed pinacol in the product mixture. Whilst observed yellow colouration in the reaction may be due to the presence of B, Weiner⁶⁶ concluded that the yellow intermediate cannot be transformed into products at a rate consistent with his earlier studies.

The low efficiency of photoreduction in benzene has resulted in the solvent being used in many sensitization experiments. However, there is a low quantum yield of reduction even with benzene solvent and observations concerning the actual behaviour of benzophenone triplets in benzene solvents are confusing.⁸³ The value given for the quantum yield of disappearance of benzophenone in Table 2.4 is 0.05 and is the upper limit as determined by Beckett and Porter.⁷⁷ Bell and Linschitz⁸⁴ estimated a quantum yield of 0.1 for formation of the primary ketyl radical $\text{Ph}_2\dot{\text{C}}\text{OH}$ compared to 0.022 ± 0.006 found by Buettner and Dedinas.⁸⁵ Deactivation of triplets in benzene has been suggested^{86,87} to occur via formation of biradical intermediates of the type shown in Figure 2.13 (for benzophenone). Schuster and Brizzolara⁸⁷ have

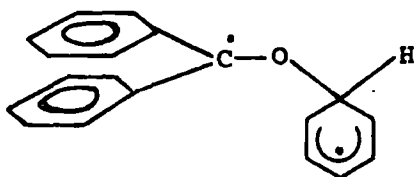


Figure 2.13

pointed out that this provides a path for formation of biphenyl according to the scheme in Figure 2.14.

The major products from irradiation of benzophenone in benzene (6×10^{-3} M solution) at 290 nm are biphenyl and benzopinacol and ¹⁴C studies have recently shown that the biphenyl is essentially solvent derived.⁸³ Schuster

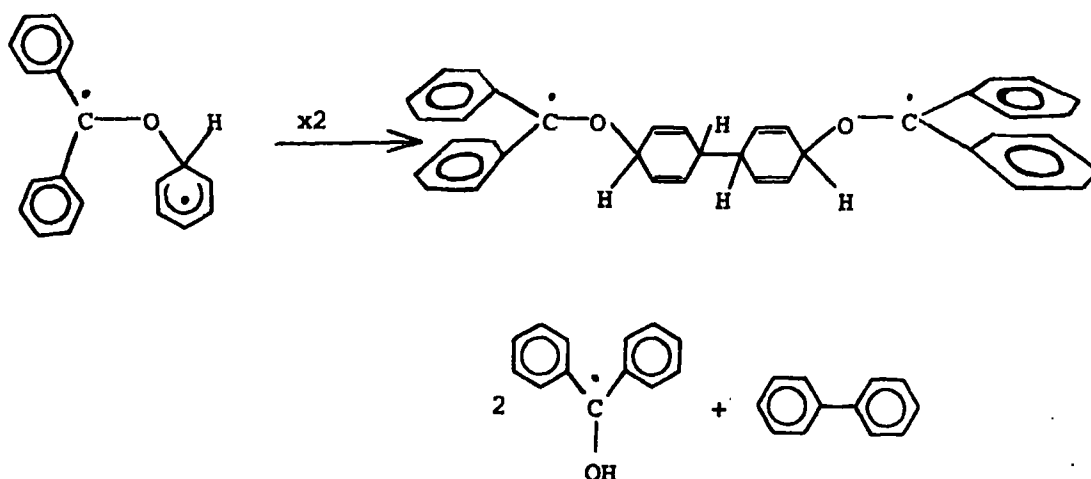


Figure 2.14

suggested⁸⁸ that the quenching of benzophenone triplets in aromatic solvents involves an interaction incorporating at least partial charge transfer from ketone triplet as donor towards aromatic as acceptor.

2.1.b.ii. Spin flipping and reactions within the solvent cage

The photoreduction of benzophenone by toluene and cumene is known to yield tertiary alcohols,^{76,89} cross coupling products resulting from the combination of the benzophenone ketyl radical and substrate radicals (Figure 2.15). As already mentioned, most workers denied the existence of such a product for the benzophenone/isopropanol system until Weiner⁶⁶ identified the mixed pinacol by analytical g.l.c. The 2-methyl-1,1-diphenyl-1,2-propanediol has been obtained in 18% yield in the electrochemical reduction of benzophenone in acetone-water mixture.⁹⁰ Irradiation of benzophenone in methanol results in the formation of the mixed pinacol and Mauser obtained the 1,1-diphenylglycol ($\text{Ph}_2\text{C}(\text{OH})-\text{C}(\text{OH})\text{H}_2$) in 5% yield.^{80,91} In isopropanol, the cross pinacol was estimated to be present in the product to the extent of 11% by Weiner and less than 4% by Götzmer.⁹² When camphorquinone was used to

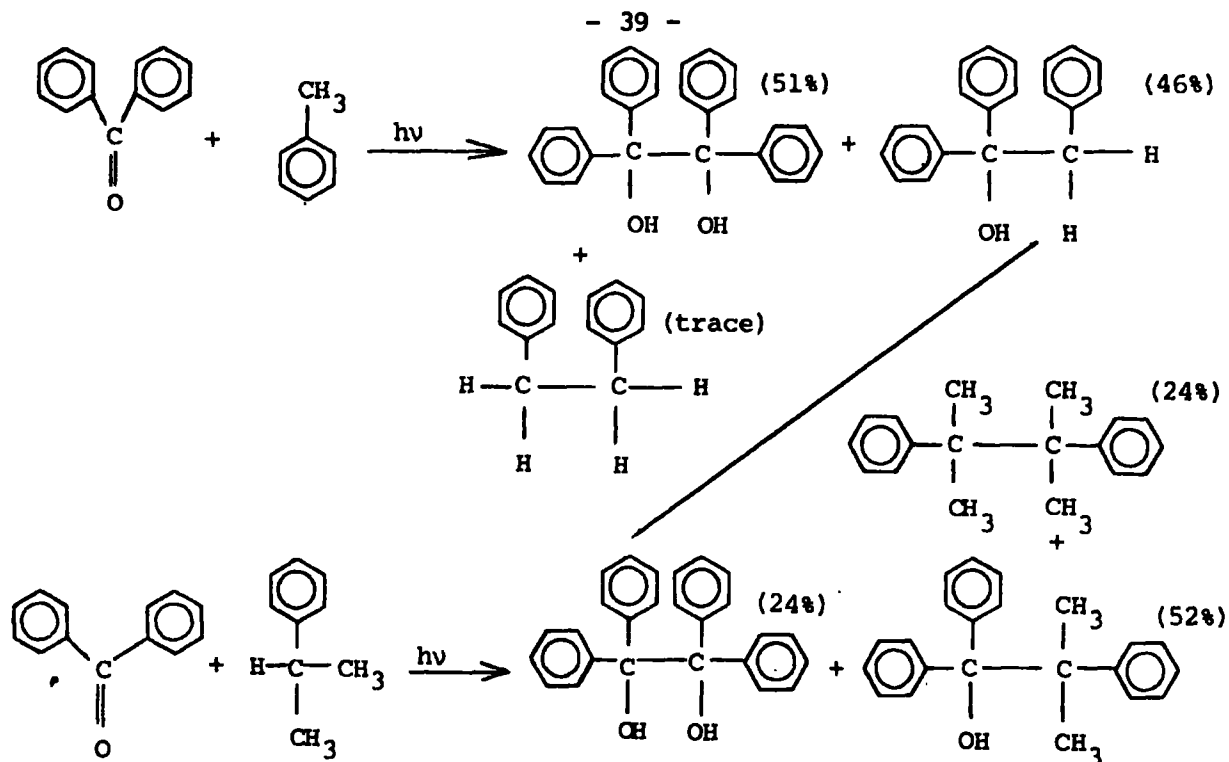


Figure 2.15

scavenge all the free ketyl radicals which diffuse out of the solvent cage, irradiation of benzophenone in isopropanol yielded the cross pinacol along with benzhydrol. The ratio of benzhydrol to the cross pinacol was found to be 0.8. This is good evidence that the mixed pinacol results, at least in part, from a cage reaction.^{66,92}

The irradiation of benzhydrol in acetone generated the same radicals as the benzophenone-isopropanol system. However, a greater amount of the mixed pinacol is found among the products of the former reaction, possibly because of differences in the solvents forming the cage. Both systems show the same light-absorbing intermediate.⁸¹

Complete reduction of the carbonyl group occurs when a benzophenone ketyl radical abstracts a hydrogen atom from an acetone ketyl radical. Abstraction of a hydrogen atom from a benzophenone ketyl radical by an acetone ketyl radical is estimated to be negligible since the quantum yield for benzophenone disappearance is high (up to 2); also the energetics of the process agree with this conclusion since the O-H bond strength in benzophenone

ketyl radical is 35 kcal mole⁻¹ whereas the bond strength in an acetone ketyl radical is only 20 kcal mole⁻¹. The fact that in the irradiation of benzophenone in (-)-2-butanol⁹³ the recovered solvent is not racemized could be considered as evidence in favour of the above hypothesis.

Unlike benzophenone which undergoes a one electron reduction process to yield pinacol, photolyses of di(2-pyridyl)ketone, di(4-pyridyl)ketone and 4-pyridyl-phenylketone in isopropanol lead to the formation of the corresponding dipyridylmethanols and 4-pyridylphenylcarbinol as the only products in each case.^{94,95} It has been shown that the lowest n,π* triplet state of these ketones is involved in the hydrogen abstraction reaction. The complete reduction of the carbonyl chromophore in the heterocyclic ketones may be rationalized by the difference in electronegativity between nitrogen and carbon. Since there is a higher probability of finding the electron of the ketyl radical on nitrogen, the transfer of a hydrogen atom from the acetone ketyl radical yields the conjugated enol which reverts to the carbinol by prototropism (Figure 2.16). Thus it can be seen that the reducibility of

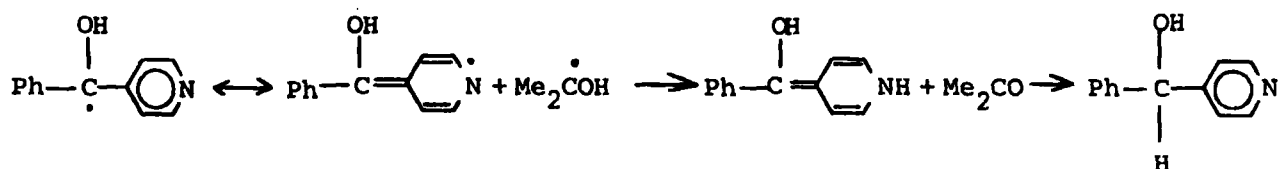


Figure 2.16

carbonyl compounds depends on the nature of the carbonyl double bond and its substituents, and is sensitive to structure modifications which affect the electron distribution, particularly the π-electron delocalization. Similarly, aromatic ketones whose triplet states possess pronounced π,π* character are

more susceptible to complete reduction. In the case of the photoreductive coupling of bisbenzophenones, this imposes some limits on polymer formation.

2.1.b.iii. The yellow intermediate observed in the photoreduction of aromatic ketones

As has been pointed out already the formation of a yellow intermediate is a characteristic feature of the photoreduction of benzophenone in alcohol.^{81,96} Several explanations have been put forward to account for this intermediate, and these were reviewed by Filipescu who concluded, mainly on the basis of spectroscopic evidence that the most likely structure was the conjugated enol discussed earlier (Figure 2.10).⁸¹ Nevertheless a definitive proof of the structure of this frequently observed intermediate has eluded the many investigators who have worked on the problem.

In the photoreduction of heteroaromatic ketones intermediates have also been detected spectroscopically, for example di(4-pyridyl)ketone gives an intensely absorbing species on photoreduction in isopropanol.⁹⁴ However, the detection of intermediates during photoreduction is by no means universal, for example no intermediate could be detected during the photoreduction of di(2-pyridyl)ketone⁹⁴ and the yellow colour associated with the photoreduction of benzophenone in isopropanol is not observed when benzhydrol is the donor.⁹⁷

Despite the difficulty in unequivocally identifying the intermediate(s) involved in photoreduction the structure proposed by Filipescu seems a reasonable candidate since there is a body of information in the literature which can be rationalized in terms of initial coupling between the radical derived from the hydrogen donor and the benzophenone ketyl radical, such coupling occurring at the ortho or para positions of a phenyl ring. Decafluorobenzophenone provides a good example; this ketone, unlike benzophenone is photoreduced in isopropanol exclusively to decafluorobenzhydrol ($\phi = 0.6$).⁹⁸ Although the primary photochemical step should be a hydrogen abstraction by

the n, π^* triplet state since this ketone shows the same properties as benzophenone (similar absorption spectrum, identical n, π^* lowest triplet energy, and efficient intersystem crossing). The failure to isolate the pinacol may arise from the instability of the perfluoropinacol itself. Dedinas⁹⁹ reported that the photoreduction of decafluorobenzophenone in cyclohexane yields, in addition to the cross coupling product, ortho and para substituted nonafluorobenzophenones. The formation of these products was rationalized as shown in Figure 2.17.

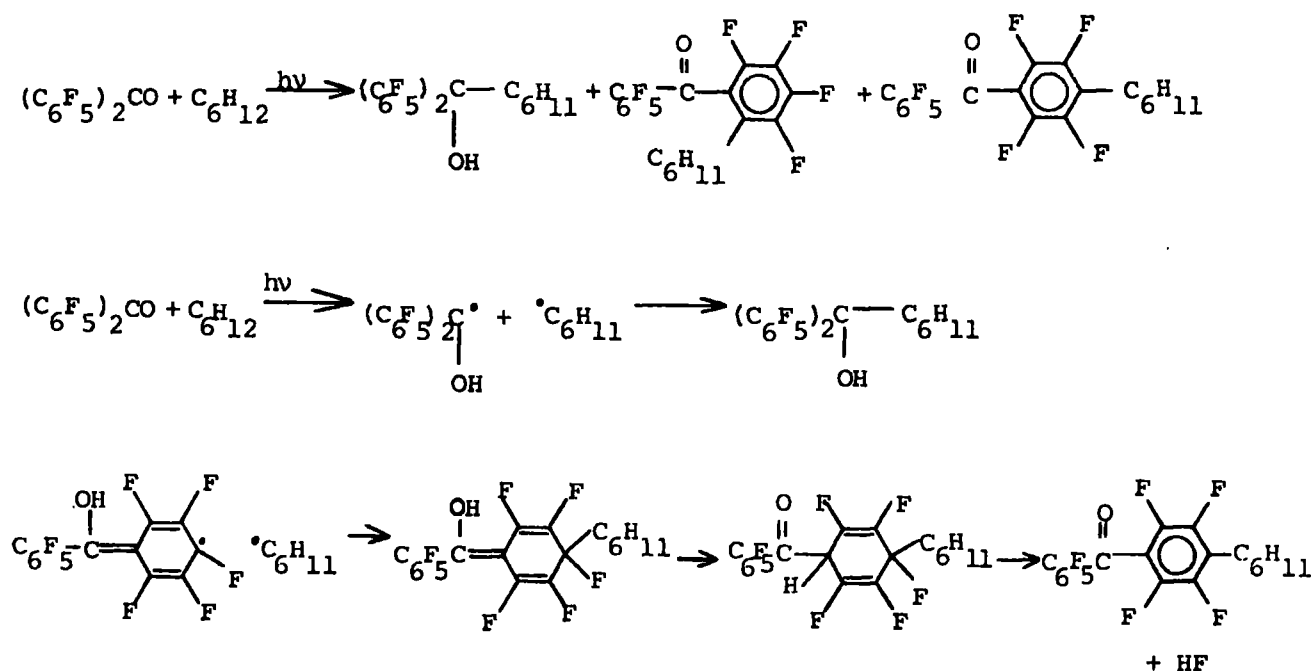


Figure 2.17

Irradiation of acetophenone in a mixture of ether and cyclohexane gives acetophenone pinacols in good yield, together with 2-butanol derivatives and a *p*-substituted acetophenone¹⁰⁰ (Figure 2.18). The acetophenone ketyl radical and ether radical combine to yield the 2-butanol derivatives in a manner analogous to the formation of 1,1,2-triphenylethanol in the photoreduction of benzophenone in toluene. The formation of the *p*-substituted acetophenone can be rationalized by postulating that the delocalized ketyl radical is attacked at the para position by the ethoxy ethyl radical to give the enolic intermediate which would be expected to be oxidized by air to yield the observed product.

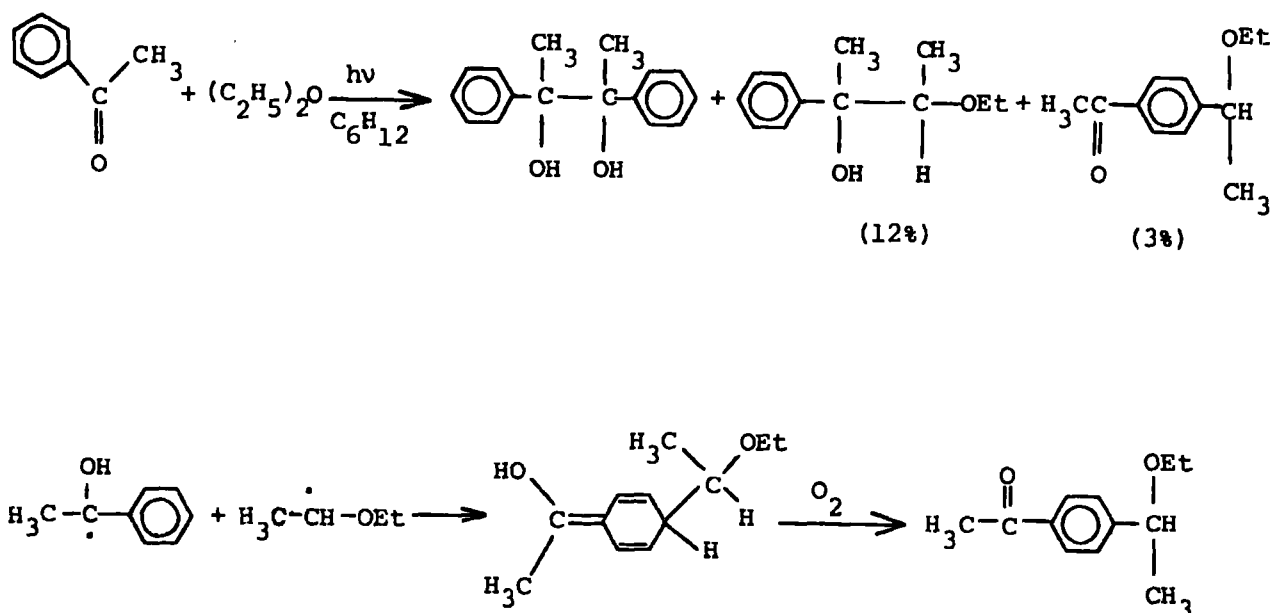


Figure 2.18

The reduction of benzophenone in water is also consistent with this pattern of reaction.^{101,102} In the absence of oxygen benzopinacol is obtained whereas in aerated solution hydroxybenzophenones are formed ($\phi = 0.02$), and a transient assigned as a hydroxyl radical adduct of benzophenone was observed.

2.1.b.iv. Complex formation between ketyl radical and ketone

The fate of the benzophenone ketyl radical and the acetone ketyl radical which diffuse out of the solvent cage has been explained in terms of two reactions. Hydrogen atom transfer from the acetone ketyl radical to a ground state benzophenone molecule results in the formation of a new benzophenone ketyl radical. Benzopinacol is then formed from the dimerization of two benzophenone ketyl radicals. This mechanism appears plausible since the acetone ketyl radical has a high probability of encountering a benzophenone molecule which is in excess. The disappearance of the benzophenone ketyl radical is found from electron spin resonance and flash photolysis studies to follow second order kinetics. Accumulating evidence shows that the photoreduction of

benzophenone in benzhydrol does not always proceed through a direct combination of the two primary radicals; in the photochemical reaction between an excess of deuterated benzophenone and non-deuterated benzhydrol, perdeuterated, half-deuterated and non-deuterated benzopinacols were not obtained in the expected statistical distribution;¹⁰³ in practice large amounts of benzopinacol d_{20} , and small quantities of mixed pinacol d_{10} and pinacol d_0 were obtained. The result can be rationalized by a reversible hydrogen atom exchange occurring in a benzophenone-ketyl radical complex (Figure 2.19).

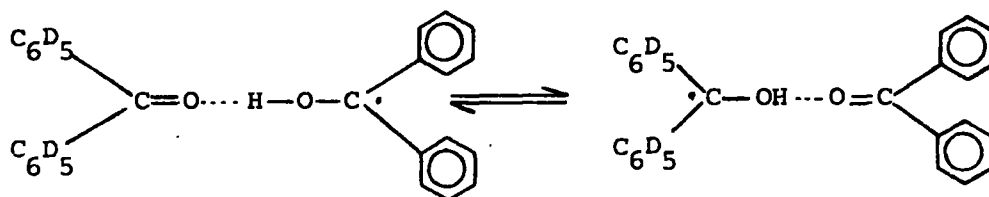


Figure 2.19

Since deuterated benzophenone was used in excess, the equilibrium was driven towards the direction of the deuterated ketyl radical, resulting in a greater amount of benzopinacol d_{20} being formed.

Schenck¹⁰³ reported that the irradiation of a solution of benzophenone- d_{10} (in excess) and benzopinacol- d_0 in benzene resulted in the formation of benzopinacol- d_{20} exclusively (Figure 2.20). This reaction appears somewhat curious since benzopinacol is known to be inert to benzophenone n,π^* triplet state at the usual wavelength (350 nm) employed in the photoreduction.¹⁰⁴ The wavelength selected by Schenck was not specified;¹⁰³ it is, however, probable that short wavelength ultraviolet light was used, since the C-C bond in the pinacol can be cleaved by irradiation at 240 nm, or thermally. One way of interpreting the results is in terms of the equilibria

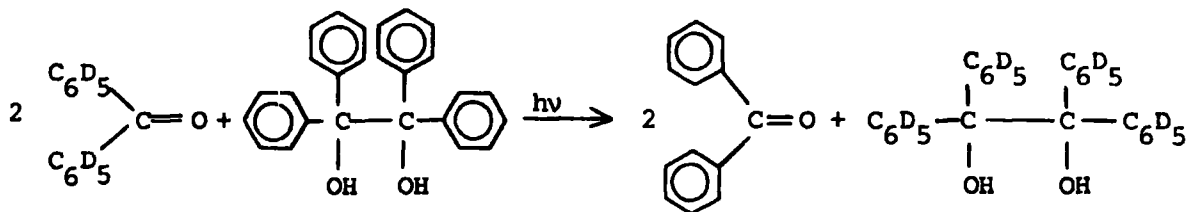


Figure 2.20

shown in Figure 2.21.

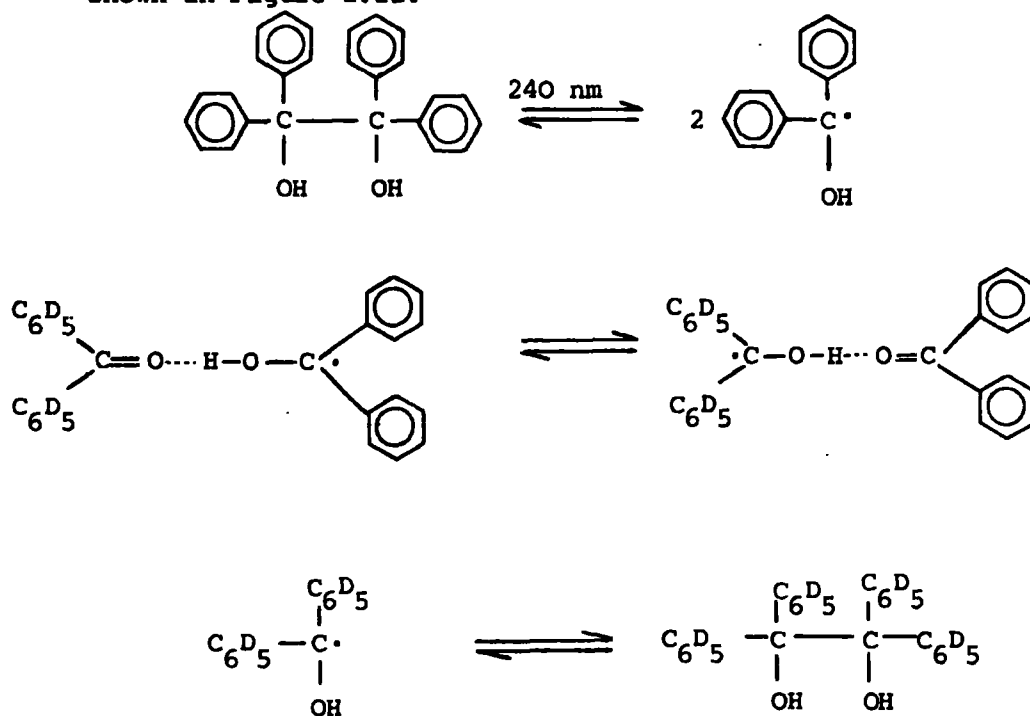


Figure 2.21

Further reports by Franzen¹⁰⁵ tend to indicate that the pinacol does not form from a direct combination of the primary ketyl radicals. The photoreduction of benzophenone in the presence of benzhydrol yields two identical radicals which however can be distinguished by ¹⁴C labelling. Franzen irradiated a

benzene solution containing benzophenone ^{12}C and benzhydrol ^{14}C ; a mixture of benzophenone and benzopinacol as shown in Figure 2.22 was obtained. The

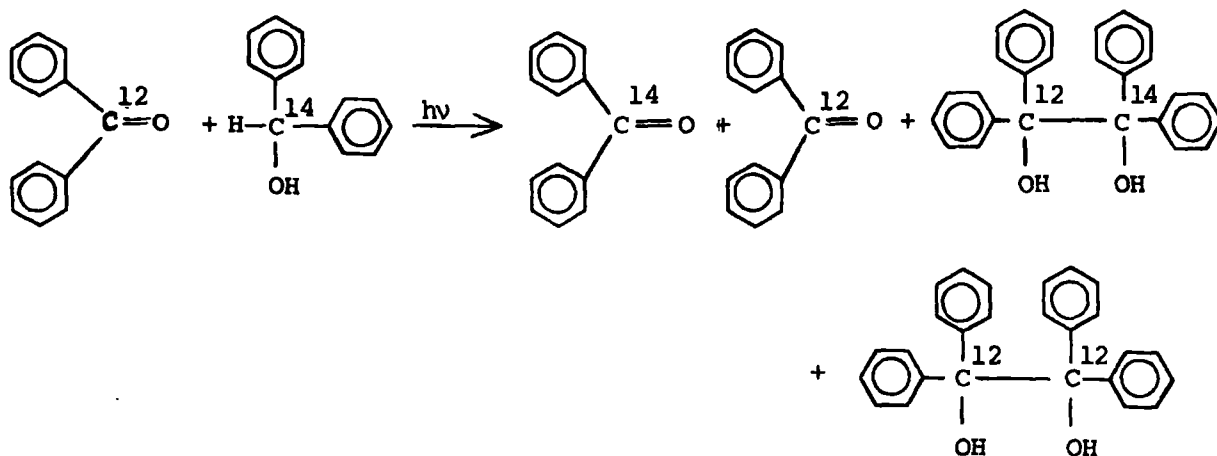


Figure 2.22

experimental results are consistent with a redox reaction between benzophenone and diphenylhydroxymethyl radical. The radioactivities of the pinacols formed were found to be less than half the activities of the initial benzhydrols. Also, the radioactivity of the pinacols was found to decrease with increasing benzophenone ^{12}C concentration (Figure 2.23).

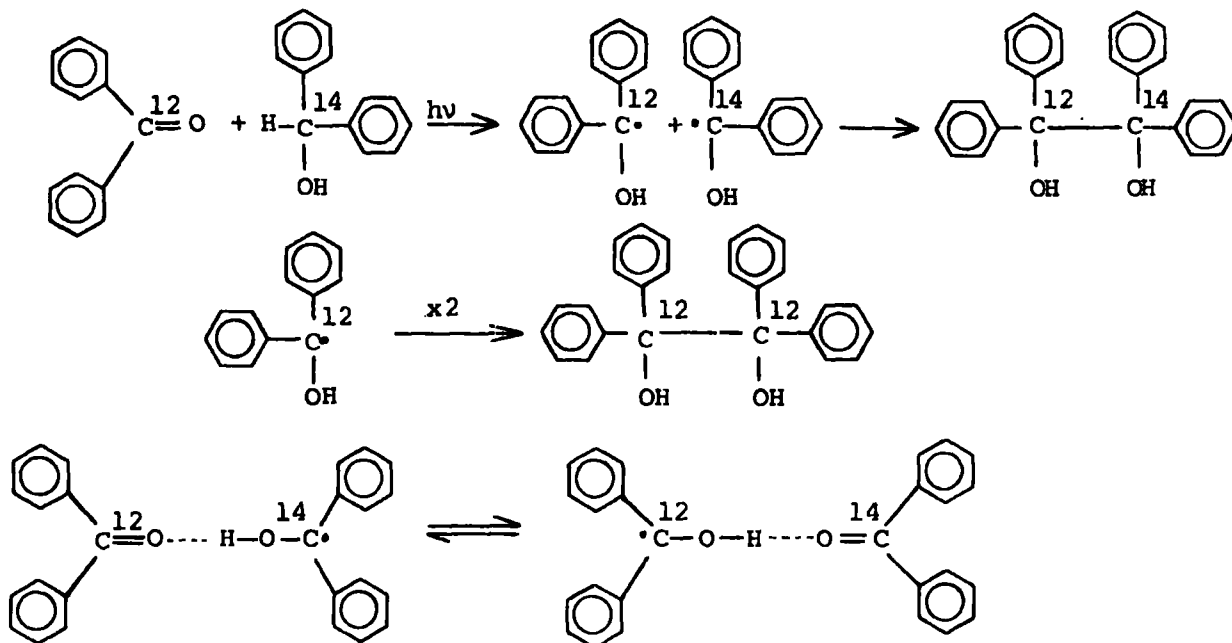


Figure 2.23

Furthermore, the existence of the hydrogen atom exchange between benzophenone and a ketyl radical has been established by electron spin resonance studies.¹⁰³ The acetone ketyl radical would also be expected to form a hydrogen bridge with a basic oxygen atom. In this sense, a ketyl radical/ketone complex should be envisaged to rationalize the hydrogen atom transfer in the photoreduction of benzophenone in isopropanol¹⁰³ (Figure 2.24).

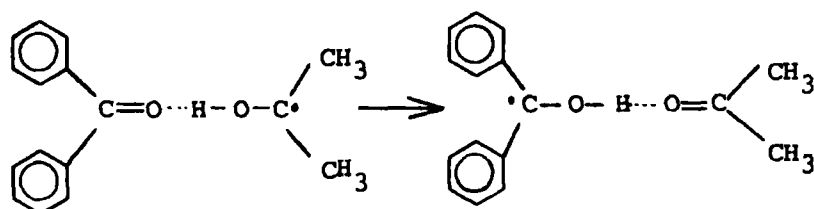


Figure 2.24

2.1.b.v. Effect of structure on photoreduction of aromatic ketones

Not all ketones are photoreduced to give pinacols. The reactivity of aromatic ketones has been rationalized in relation to the lowest lying triplet levels of the ketone.¹⁰⁶ When the lowest lying triplet level has n, π^* character, ketones are generally readily reducible with quantum yields frequently approaching unity. Ketones which possess a π, π^* configuration for the lowest triplet state, however, are much less disposed towards photoreduction, an example being p-phenyl benzophenone. It is suggested that the higher efficiency in photoreduction processes of the n, π^* state may arise from the highly localised n electron of the oxygen, whereas in the π, π^* triplet state the unpaired electrons are more delocalized and hydrogen abstraction is thus more endothermic.^{55,107} (Figure 2.25.)

A third type of possible lowest lying triplet state is a charge transfer state.¹⁰⁶ In p-aminobenzophenone represented by the formula DRA, where D is

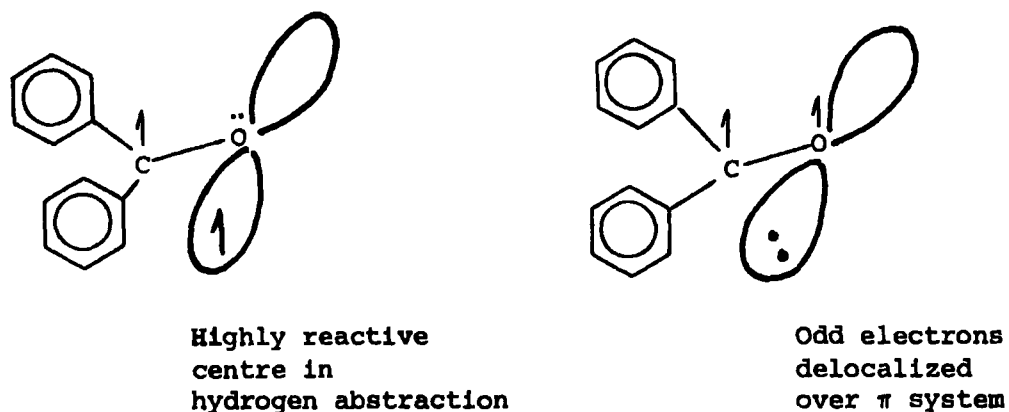


Figure 2.25

the electron-donating amino group, R is the aromatic ring, and A is the electron-accepting carbonyl group, three important charge-transfer states may be considered. These are DR^+A^- corresponding to the charge-transfer state of benzophenone, D^+R^-A corresponding to the charge-transfer state of aniline and D^+RA^- . The three states interact with one another to give a new low energy charge-transfer (C-T) state not present in benzophenone or aniline. The negative charge on the oxygen in this C-T state results in virtually zero reactivity towards hydrogen atom abstraction. Polar solvents such as isopropanol should enhance intramolecular charge-transfer from the electron donating group to the carbonyl group, thus helping to decrease the energy of such charge-transfer states below that of the n,π^* state. Thus in isopropanol where the C-T state of p-aminobenzophenone is the lowest lying triplet state, the quantum yield of pinacolization is zero. In a less polar solvent such as cyclohexane, where the charge-transfer triplet is no longer the lowest lying triplet, photopinacolization of p-aminobenzophenone has been shown to occur quite readily with a quantum yield of 0.2.¹⁰⁸ p-Hydroxybenzophenone has been

reported to behave in a similar manner, the molecule reacting in the basic form in the excited state where the pK of its protonation equilibrium is much lower than in the ground state. In accord with this theory aminobenzophenones can be reduced in isopropanol when converted to their onium salts. However, many of these results have recently been questioned and are now suspect.^{109,110} Thus in relation to solvent effects on the substituted benzophenones, although the ketones are unreactive in isopropanol, but react in cyclohexane, the process, in fact does not appear to involve hydrogen atom abstraction leading to pinacols. Pitts¹⁰⁹ states that no pinacol is formed on irradiation of p-aminobenzophenone in cyclohexane. He emphasizes that spectrophotometric methods of analysis have frequently been employed in studying benzophenones and that these methods involve disappearance of reactant rather than appearance of product. Thus alterations in reaction paths arising from uncontrolled environmental changes and leading to products other than pinacols may not be observed. Pitt's contention is underlined in studies reported by Cohen¹¹⁰ of solvent effects on the isomerization of trans-stilbene in the presence of benzophenone and aminobenzophenones, he suggested that the failure of p-aminobenzophenone to photoreduce in polar solvents results from essentially the complete absence of triplets rather than the charge-transfer state itself being unreactive.

Pinacols may only be isolated following photochemical reduction of aryl ketones in isopropanol, if the pinacols are themselves stable in irradiated acetone solutions.⁶⁷ Thus 9,9'-dihydroxy-9,9'-bixanthene is converted into xanthen-9-one in sunlight,⁷⁰ and correspondingly xanthen-9-one is not converted to the pinacol on irradiation in isopropanol (Figure 2.26).

Ortho substituted aromatic ketones, or those with other substituents which can form a six-membered ring, hydrogen bonded to the carbonyl oxygen, may tautomerize in an intramolecular hydrogen abstraction reaction. Thus

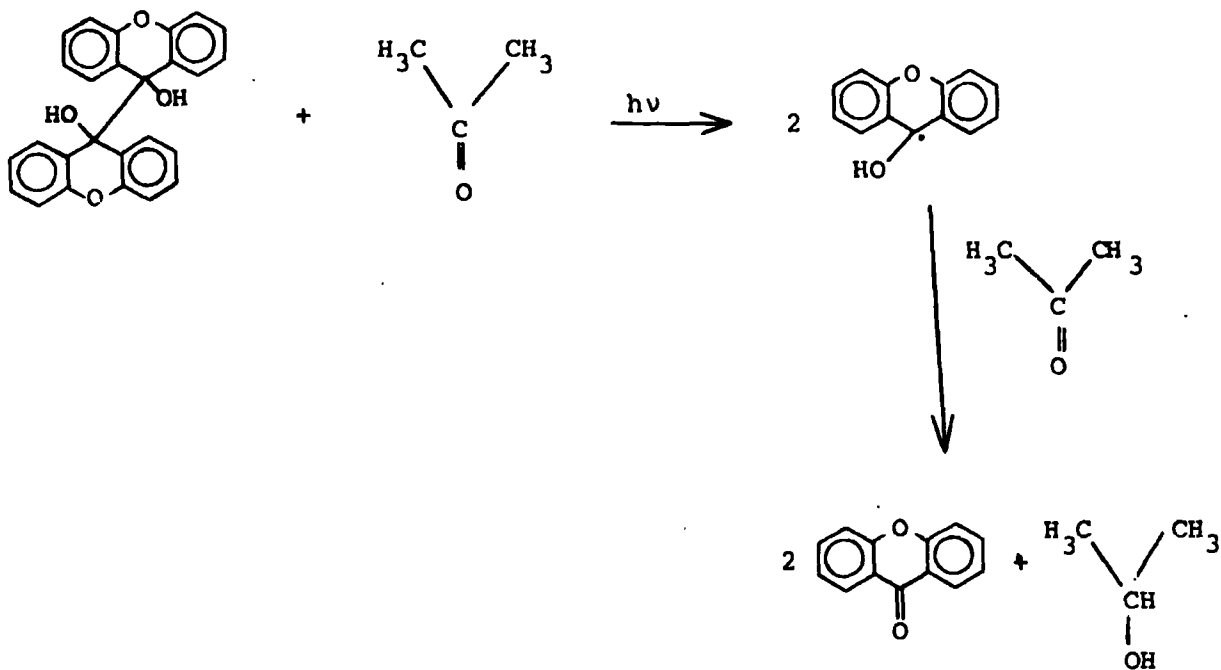


Figure 2.26

2-methylbenzophenone forms an enol under the influence of ultraviolet light, to the complete exclusion of photoreduction.¹¹¹

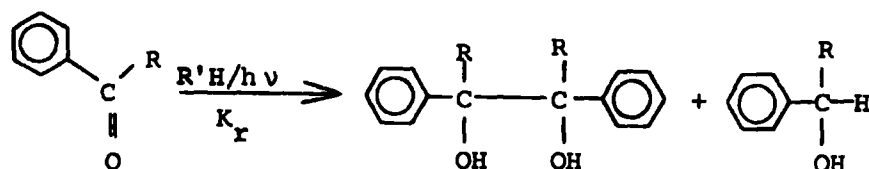
2.1.b.vi. Steric effects on photoreduction

The excited ketone molecule must come into close contact with the alcohol molecule in order for the abstraction of the α -hydrogen to take place, and any bulky substituents in the aromatic ketone or alcohol which are close to the reaction centre could hinder the interaction of the reactants and lower the rate of hydrogen abstraction.

The photolysis of alkylphenyl ketone in isopropanol-benzene, yields a mixture of acetone, dl and meso pinacols and the corresponding hydrols with $\phi_{\text{acetone}} = \phi_{\text{pinacol}} + \phi_{\text{hydrol}}$.¹¹² The quantum yield for hydrol formation is found to increase while that of pinacol formation and the rate constant for hydrogen abstraction decrease with α -substitution becoming bulkier (Table 2.5).

Table 2.5¹¹²

Comparative photolyses of some alkylphenyl ketones



R	ϕ pinacol	ϕ hydroxyl	Rate constant in isopropanol $k_r M^{-1} \text{ sec}^{-1}$	Rate constant in 2,4-dimethyl-3-heptanol $k_r M^{-1} \text{ sec}^{-1}$
-CH ₃	0.34	0.007	7.5×10^5	2.8×10^5
-CH ₂ CH ₃	0.19	0.033	4.4×10^5	2.5×10^5
-CH(CH ₃) ₂	0.07	0.049	1.3×10^5	0.5×10^5
-C(CH ₃) ₃	0.00	0	---	---
◇	0.20	unknown	1.0×10^5	---

The identical rate constant for triplet decay $k_d (= 3 \times 10^5 \text{ sec}^{-1})$ found for the ketones in Table 2.5 suggests that increased steric hindrance makes hydrogen abstraction more difficult. *t*-Butylphenylketone does not undergo photoreduction, it yields benzaldehyde instead by an α -cleavage followed by hydrogen abstraction. Ortho substituted benzophenones also fail to pinacolize; although orthomethylbenzophenone is photostable prolonged irradiation of 2,4,6-trimethylbenzophenone in isopropanol leads to 2,4,6-trimethylbenzhydroxyl as the reduction product.^{113,114}

The solvent can also contribute to steric hindrance. The lower rate constant for hydrogen abstraction in 2,4-dimethyl-3-heptanol (Table 2.5)

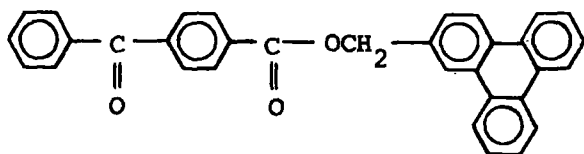
relative to isopropanol, reflects a substantial decrease in reactivity. The decreasing rate of benzophenone photoreduction in going from isopropanol (relative reactivity 1.0), through methyl-t-butylcarbinol (0.90), methyl-isobutylcarbinol (0.39) to methylneopentylcarbinol (0.18), has been attributed to steric hindrance as solvent chain branching increases.^{115,126}

2.1.b.vii. The temperature effect on photoreduction

For aromatic ketones possessing nearly degenerate n, π^* and π, π^* triplet states, the relative populations of these states at thermal equilibrium are given by the Boltzmann distribution

$$\frac{N(n, \pi^*)}{N(\pi, \pi^*)} = e^{-\frac{\Delta E_T}{RT}}$$

ΔE_T being the energy gap separating the two states. The phosphorescence intensity of a non-conjugated bichromophoric system such as the ester shown in Figure 2.27 is approximately the sum of the phosphorescence of benzophenone



$$E_T = 2 \text{ kcal mol}^{-1}$$

Figure 2.27

and triphenylene in a ratio $I_T:I_B = 1.5$ at 77K. At room temperature the ratio $I_T:I_B = 0.20$.⁸⁶ The relative population of benzophenone triplet increases via thermal activation and the emission occurs more rapidly from the short-lived n, π^* triplet. It is therefore expected that for aromatic ketones exhibiting a lowest π, π^* triplet with a nearby n, π^* triplet, the reactivity towards hydrogen abstraction will increase with increasing temperature. The

increase in the rate of hydrogen abstraction with temperature when 2-acetonaphthone is irradiated in ethanol could be due to a significant increase of the n, π^* triplet population.¹¹⁷

On the other hand, the use of high temperatures may have a dramatic effect on the final products. Irradiation of benzophenone in isopropanol at sufficiently high temperatures produces increasing amounts of benzhydrol; at 150°C, benzhydrol becomes nearly the exclusive product, resulting from the disproportionation of two benzophenone ketyl radicals.¹¹⁸

2.1.b.viii. Photoreductive addition of ketones to methylene groups

Carbonyl compounds may undergo photoaddition to methylene groups adjacent to double bonds or aromatic systems. Benzophenone has been reported to react with diphenylmethane in sunlight to form 1,1,2,2-tetraphenylethanol¹¹⁹ whereas irradiation of benzophenone with bis-(4-methoxyphenyl)methane gives the carbinol and symmetrical dimers of the radicals involved in the reaction¹²⁰ (Figure 2.28).

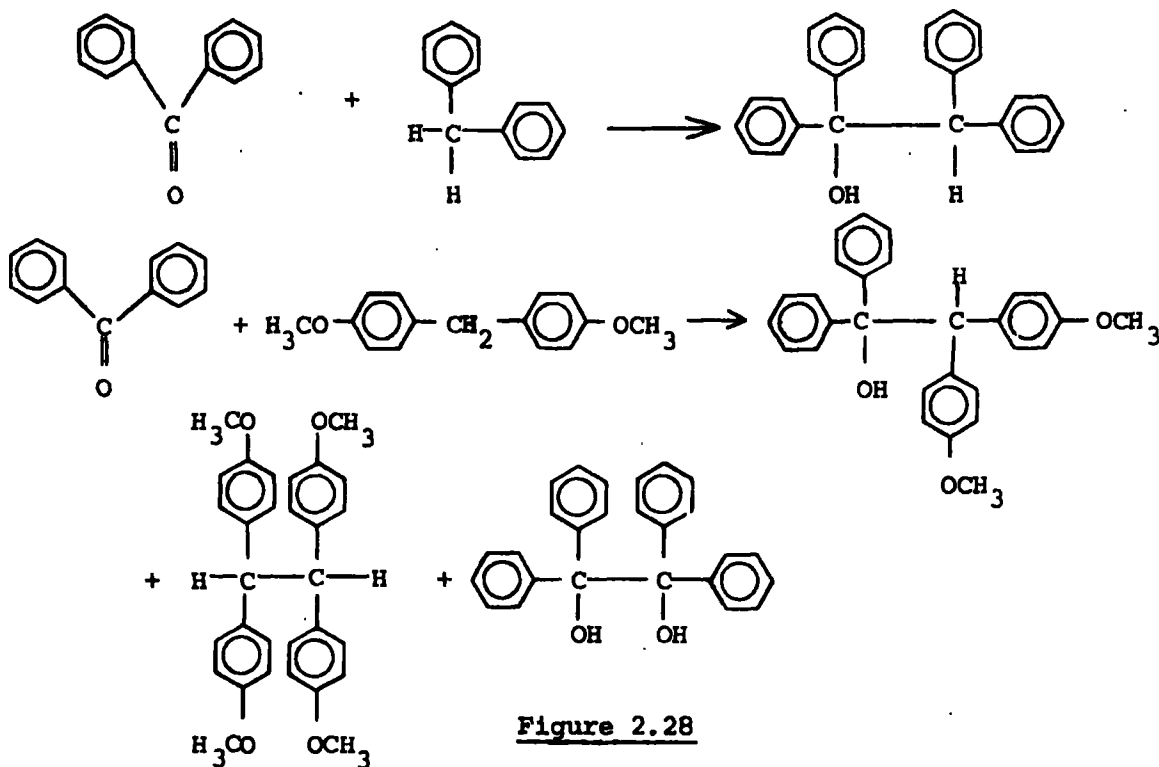


Figure 2.28

Transannular interaction between the excited carbonyl group of cyclo-dodecanone and one of the nearest methylene groups, with intramolecular cyclization, yields a tertiary alcohol¹²¹ (Figure 2.29). Many other examples

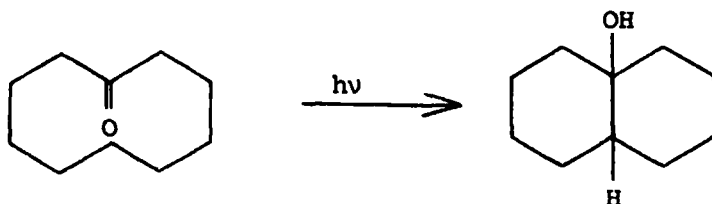


Figure 2.29

of such photoadditions may be found in the literature.¹²² Photoreductive addition of benzophenone to diphenyl methane will be dealt with in more detail in Section 2.2 of this thesis.

2.1.c. Objectives of the study

The photoreductive polymerization of aromatic bisketones has been thoroughly investigated and high molecular weight polybenzopinacols have been successfully prepared. The following sections describe attempts to extend this area of synthetic organic photochemistry.

Section 2.2 is concerned with an investigation of the possibility of preparing poly(pentaphenylglycerols) and, eventually, higher analogues (see section 1.6) by photoreductive polyaddition of bisbenzophenones to suitable hydrogen donors as illustrated in Figure 2.30. For such a process to occur the requirements would be:

- i) initial excitation of the carbonyl chromophore by 350 nm ultraviolet light,
- ii) abstraction of a tertiary hydrogen by the photoexcited carbonyl resulting in the formation of the two primary radicals shown in Figure 2.31, and

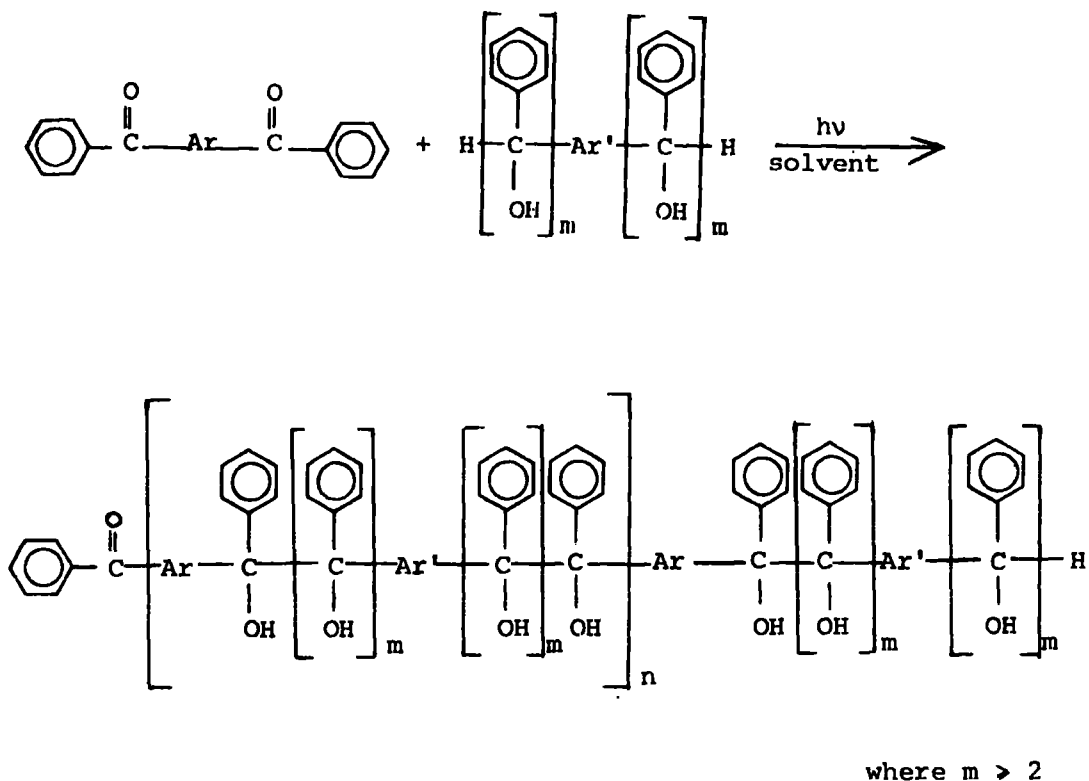
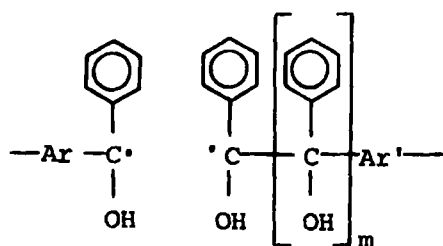


Figure 2.30

iii) combination of the two primary radicals to yield the cross coupled product.

The first objective of this exercise was therefore the careful examination

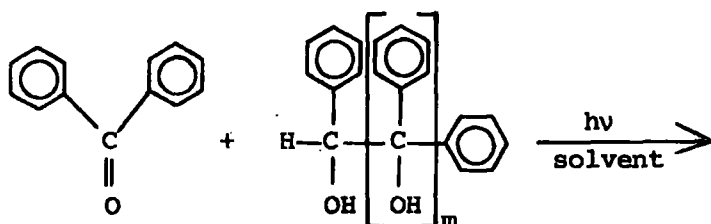


where $m > 1$

Figure 2.31

of the model reaction (Figure 2.32) in order to establish whether processes occurring on photochemical excitation of benzophenone in the presence of triphenylglycol (Figure 2.32, $m = 1$) would justify further attempts to extend

this reaction to polymer synthesis.



where $m = 1$

Figure 2.32

Section 2.3 is concerned with some investigations on the possibility of extending a reaction already mentioned in 2.1.b.viii, namely the photoreductive addition of benzophenone to diphenylmethane¹¹⁹ to polymer synthesis. This would initially require a re-examination of the model reaction, since literature reports on the formation and yield of photoproducts are somewhat confusing (see later, section 2.3). Extension of the reaction to polymer formation would involve the irradiation, under conditions optimized during the model compound studies of a bisbenzophenone in the presence of a difunctional analogue of diphenylmethane, for instance a bisbenzylbenzene.

One further reason for attempting this reaction was the possibility of obtaining technologically interesting materials by structural modification of the resulting polymer. It was thought that dehydration of the first formed poly(1,1,2,2-tetraphenylethanol) under mild conditions could afford a totally conjugated system (Figure 2.33). Such polyconjugated systems might possess interesting electrical properties. Attempts to synthesize well characterized materials of this general type have appeared frequently in the literature in recent years.¹²³

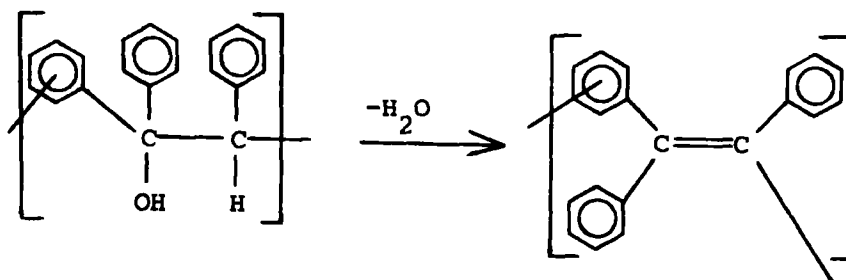


Figure 2.33

2.2. Attempts to synthesize poly(pentaphenylglycerols) and higher analogues

2.2.a. Introduction to the idea

As briefly mentioned in 2.1.c., the original idea was the synthesis of perphenylated polymers with more than two adjacent C_6H_5COH groups in the repeat unit. One conceivable way of effecting such a synthesis could in principle be the photoreductive polyaddition of an aromatic diketone to a suitable hydrogen donor, as illustrated in Figure 2.30. On the basis of literature information regarding the behaviour of photoexcited carbonyl groups of the benzophenone type in the presence of hydrogen donors it might be expected that irradiation of such a mixture at the appropriate wavelength would result in the formation of the two primary radicals shown in Figure 2.31. The question to be answered was whether the cage reaction between the two radicals would take place, and if so to what extent; further it was essential to know what other processes, if any, would occur. Possible reaction paths for the two primary radicals considered beforehand are illustrated in Figure 2.34. It can be seen that the cage reaction is the only process which would bring about formation of a homopolymer. Diffusion out of the cage and dimerization of radical K would result in the formation of a structure with a pinacol unit in it; a similar path for radical L would give a structure with

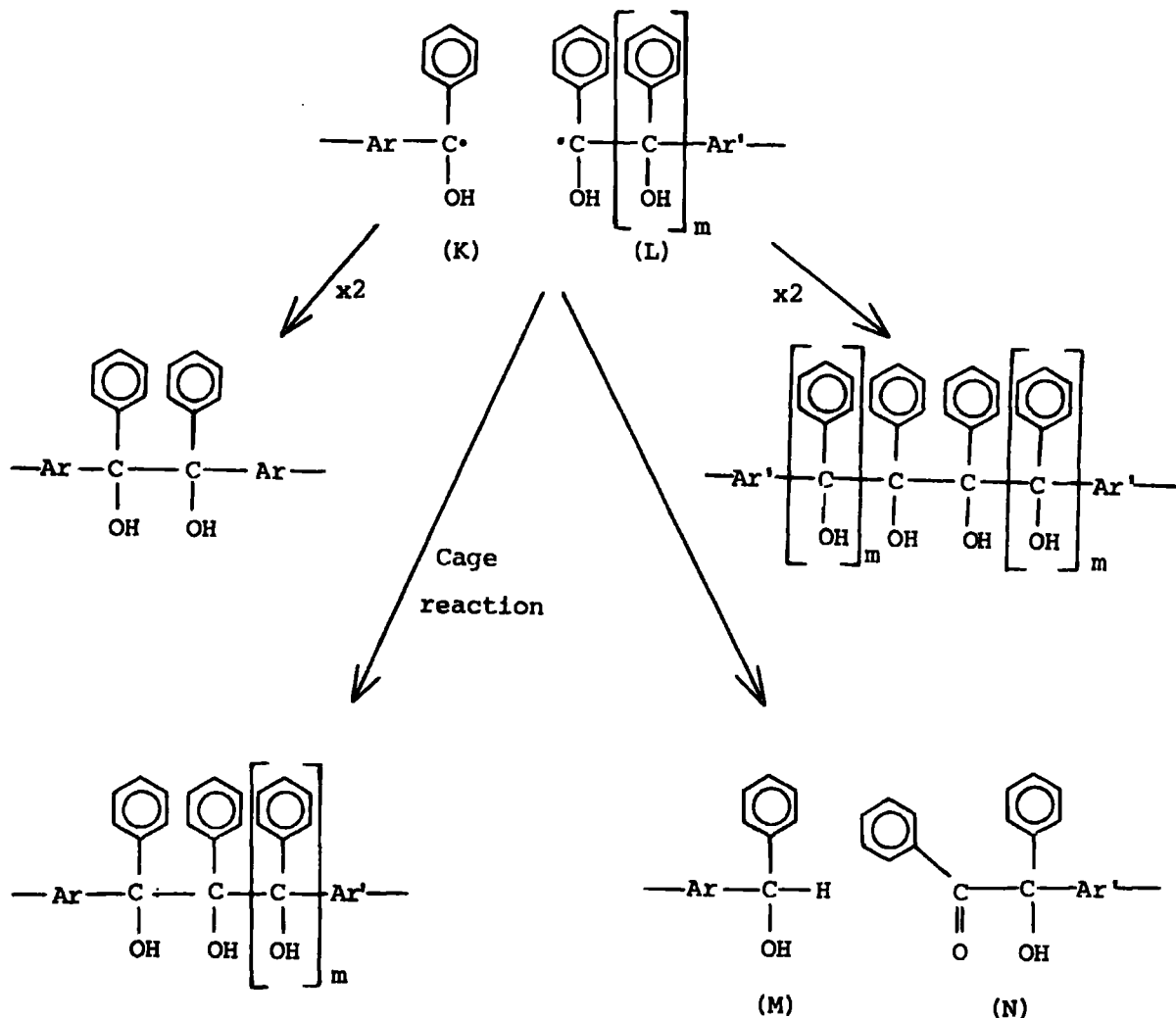


Figure 2.34

$2m+2 \text{ C}_6\text{H}_5\text{COH}$ units. A hydrogen atom transfer from radical L to radical K would result in complete reduction of the bisbenzophenone to the benzhydrol-ended product (M) and oxidation of the alcoholic reagent to structure N. Formation of end groups of the type M need not necessarily be chain terminating for polymer growth since they can interact with aromatic ketones of the benzophenone type to give pinacol links. End groups of type N however might create more of a problem since they might be expected to undergo photochemical cleavage to give radicals; benzoin is widely used as photoinitiator for radical polymerization. All the other steps indicated in Figure 2.34 are chain

propagating, although if all three radical combination processes shown in the Figure occurred the resulting polyol would be a copolymer containing repeating units with varying numbers of adjacent C_6H_5COH groups, 2 , $m + 2$, $2m + 2$. It was decided to proceed with this idea in the hope that at least some information on the photochemical behaviour of these systems would be obtained; the reaction shown in Figure 2.35 was chosen as an initial objective for this investigation.

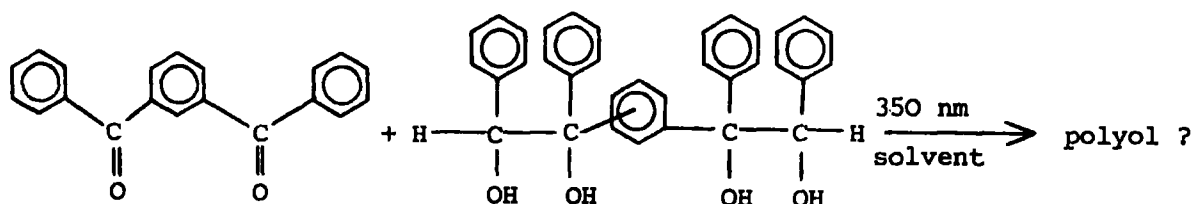


Figure 2.35

The study of the model reaction is an essential preliminary step in the investigation of any potential step-growth polymerization. It was in this context that the photoreaction between benzophenone and triphenylglycol was undertaken, the product(s) of this reaction being appropriate model(s) for the repeat unit(s) of the anticipated polyol (Figure 2.35).

2.2.b. How one event led to another

Appropriate starting materials are essential for chemical reactions. In the case of the investigation proposed in the preceding paragraph, one of the starting materials, benzophenone, was readily available. Triphenylglycol, however, had to be synthesized from simpler chemicals.

One of the standard texts of organic photochemistry⁶⁷ reported the reaction shown in Figure 2.36. No mention of by-products or reaction conditions appeared in the text. A reference was made to an old paper by

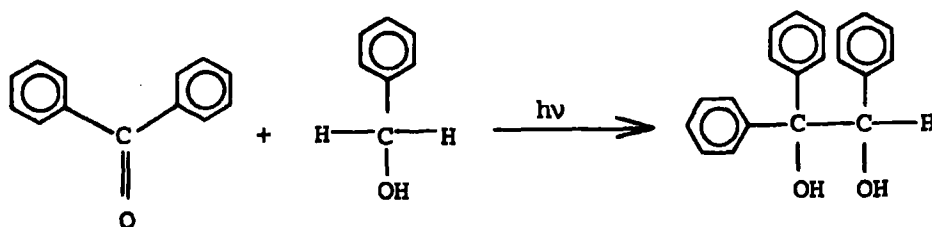


Figure 2.36

Ciamician and Silber.¹²⁴ When the reaction reported was attempted on a small scale (nitrogen streamed benzene solution, 350 nm ultraviolet light) a white solid was obtained at nearly quantitative yield, which, after recrystallization and drying was found to be benzopinacol. Repetition of the reaction at various concentrations and for different irradiation times yielded constantly the same product, benzopinacol, unequivocally identified by melting point determination, elemental analyses and spectroscopic examinations. Even variation of the benzophenone-benzylalcohol molar ratio seemed to produce no alterations in the nature or yield of the final product. Examination of the solvent after irradiation by t.l.c. on silica revealed the presence of traces of benzopinacol and several other products. Consultation of the reference¹²⁴ indicated in the text⁶⁷ revealed that Ciamician and Silber themselves appeared not to be definite about the formation of triphenylglycol from the benzophenone-benzylalcohol mixture on exposure to sunlight. In the same paper, however, references were made to earlier work by Ciamician and Silber, and also by the rival group, headed by Paternò; these references appeared to be interesting from several points of view. These very early, almost prehistorical studies (by modern standards) of the 'actions of sunlight' on organic substances, however primitive and crude, have significantly contributed to the development of modern organic photochemistry

so as to deserve a brief mention in this thesis.

2.2.c. The 'pre-history' of synthetic organic photochemistry - the nature of a dispute

Synthetic studies on the photochemistry of carbonyl compounds go back to 1886 when Ciamician and Silber tried to 'establish the principal processes determined or, better say, accelerated by the solar rays'.¹²⁵ A few years later, Loew tried the first systematic classification of the 'actions of light' on organic substances.¹²⁶ In subsequent papers^{56,127} Ciamician and Silber examined the photochemistry of various carbonyl compounds and established the fact that insolation of the ketone (or aldehyde)/alcohol system results in the 'oxidation of the alcohol to aldehyde whereas the ketones (or aldehydes) transform themselves into the corresponding pinacols'.¹²⁷ Thus, benzophenone and acetophenone yielded on insolation in ethanol benzopinacol and 'acetophenopinacol' respectively; acetaldehyde was produced as well.¹²⁷

The photoreactivity of benzophenone in aromatic alcohols was also examined by Ciamician and Silber¹²⁸ but the reaction was found to be 'a lot more complicated than in the previous case, because more products are formed in this reaction'. Copious amounts of benzopinacol were isolated from the reaction of benzophenone with benzylalcohol on exposure to sunlight, together with some hydrobenzoin, $(C_6H_5CHOH)_2$. The interesting feature of this reaction was the isolation of a substance melting at 168° and giving the following elemental analyses:

	I	II
C	82.95%	82.77%
H	6.44%	6.44%

The values calculated for $C_{28}H_{18}O_2$ (the 'addition product' of the two reagents, $(C_6H_5)_2CO + C_6H_5CH_2OH$) were: C 82.76%, H 6.21%. On the basis of this evidence Ciamician and Silber assigned to the product the structure of triphenylglycol

(Figure 2.36), a compound already known at that time to have a melting point of 164° .¹²⁹

Subsequently another group of Italian workers investigating the action of sunlight on organic substances, Paternò and his collaborators of the University of Rome, began publishing their results. In a paper published in 1909 they described the photoreactivity of benzophenone with various aliphatic hydrocarbons.¹¹⁹ They confirmed what Ciamician and Silber had claimed previously, namely that in all cases examined about two thirds of the weight of benzophenone used was transformed into benzopinacol. They also reported the isolation of some 'addition products' formed in the reactions examined.

In the same paper Paternò and Chieffi also described the behaviour of benzophenone on insolation in the presence of aromatic hydrocarbons, namely benzene, toluene, ethylbenzene, p-xylene etc. They acknowledged Ciamician and Silber's work in this field¹²⁸ but they pointed out that the formation of benzopinacol in the reaction between benzophenone and cumene reported by their rivals¹²⁸ was 'an isolated observation in which the authors did not study what change did cumene undergo during the reaction'. Furthermore, Paternò and Chieffi reported the isolation of the addition product from the benzophenone/toluene insolation ($(C_6H_5)_2C(OH)CH_2C_6H_5$) in modest yield.

It should also be mentioned here that it was in this important paper that the process now famous as the Paternò-Büchi reaction and the photoreductive addition of benzophenone to diphenylmethane were first reported.

Further work by Paternò appeared in the literature on the photoreactions of acids, ethers¹³⁰ and benzylacetate¹³¹ with benzophenone. Paternò and his team also investigated the behaviour of benzophenone on insolation in the presence of various alkaloids.¹³² In most of these studies, benzopinacol was isolated in significant quantities, occasionally small amounts of the 'addition products' were obtained. Paternò and Chieffi stated that addition of benzophenone to

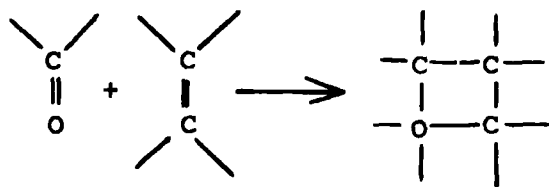
molecules was only possible when the methylene group, $-\text{CH}_2-$, was present. Similar behaviour was observed when benzophenone was irradiated in the presence of 'benzylphenol'.¹³³

In 1914, Paternò published his 11th paper on the 'Synthesis in Organic Chemistry by Means of Light'.¹³⁴ In it he summarized work already done by him and coworkers and bitterly criticized Ciamician and Silber for 'not having clearly understood the concepts of the reactions they were attempting' and for deliberately 'presenting Paternò's work under false light'. Furthermore Paternò pointed out that the evidence presented by Ciamician and Silber¹²⁸ for the formation of triphenylglycol from benzophenone and benzylalcohol was insufficient, therefore, Paternò insisted, no conclusion could be drawn as to whether the compound was actually formed in the reaction or not.

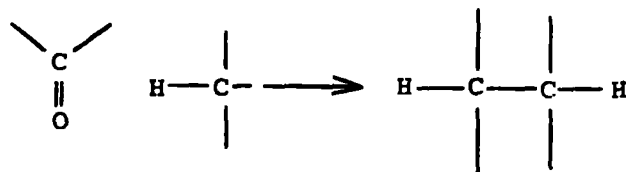
Ciamician and Silber replied¹³⁵ by saying that at the time of publication¹²⁸ they, too, had their reservations regarding the formation of triphenylglycol; they could not however, accept the charges of deliberately stating false results.

Paternò also attempted¹³⁴ an early classification of the photoreactions of carbonyl compounds as follows:

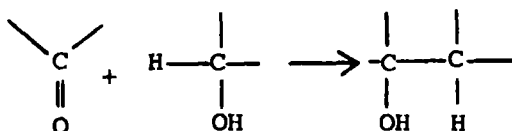
i) 'trimethylenic condensation'



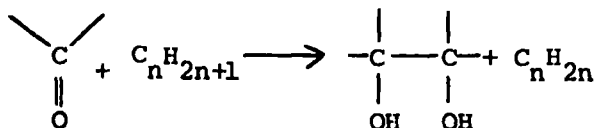
ii) 'doubling of the carbon chain'



iii) 'enolic condensation'



iv) 'dehydrogenation of alkanes'



A comprehensive review of examples for each of the above classes appears in the paper.

It is indeed hard to overestimate the importance of these early workers' efforts on the development of modern organic photochemistry. Despite the lack of helpful theoretical concepts and spectroscopic and chromatographic tools to analyse observed reactions, they patiently collected data which later on served their purpose. Speaking at the VII Congress of Applied Chemistry in London in 1909, Paternò tried to attract the attention of the young chemists of the time to the impressive results obtained in the field of photochemical synthesis. 'For us', he concluded, 'a much more modest field is reserved, the collection and preparation of the material which should serve in the construction of the majestic edifice'.¹³⁶

A point, however, which was made clear from the above information is that the two father figures of organic photochemistry never really agreed on whether triphenylglycol is produced on irradiating benzophenone in benzylalcohol or not.

2.2.d. The resolution of the dispute

In the original paper proposing the formation of triphenylglycol,¹²⁸ Ciamician and Silber described three separate insolutions of benzophenone

dissolved in neat benzylalcohol (1:2 ^{w/w}) for periods from 4 to 5 months. The main product isolated by them was benzopinacol. Other products reported were hydrobenzoin, triphenylglycol and a resin, which the authors attributed to the action of light on benzaldehyde, itself a possible reaction product arising from the oxidation of benzylalcohol. Benzaldehyde however was not isolated by them. The scheme shown in Figure 2.37 was proposed by the authors for the

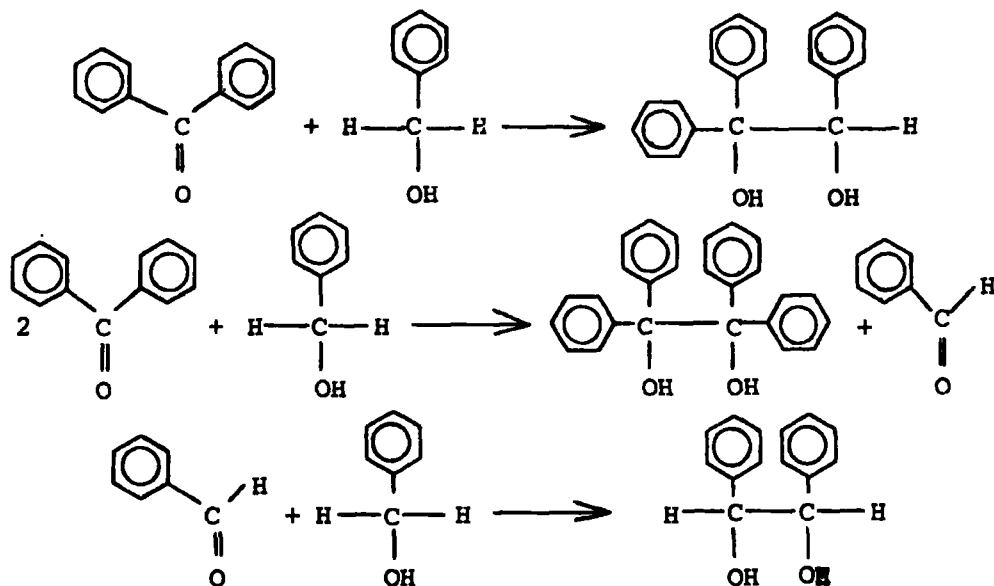


Figure 2.37

benzophenone/benzylalcohol insolation.

The reaction was re-investigated by us. A 1:2 ^{w/w} solution of benzophenone in benzylalcohol (25g:50g) was transferred into a Pyrex tube, nitrogen streamed for 20 mins, the tube was quickly stoppered and the solution was irradiated for 18 hrs at 350 nm. At the end of the irradiation period the solution was yellow and the inside surface of the tube was covered with a layer of white crystals. Examination of the tube contents by t.l.c. on silica (benzene, chloroform) and i.r. spectroscopy revealed the presence of unreacted starting materials, benzopinacol and small amounts of benzaldehyde. No triphenylglycol was isolated or detected by t.l.c. on silica; concentrations greater than 1% would have readily been detected. The reaction was repeated increasing the irradiation time to 89 hrs. Again as in the previous case the solution was yellow and the inside surface of the tube was covered with white crystals.

Benzopinacol and benzaldehyde were easily identified by t.l.c. on silica (benzene, chloroform) and i.r. spectroscopy, along with unreacted starting materials and hydrobenzoin. The interesting feature of this experiment was the detection by t.l.c. on silica of triphenylglycol. Attempts to isolate the product by fractional precipitation (ethanol solvent) were, however, unsuccessful, probably due to the small amounts of material present.

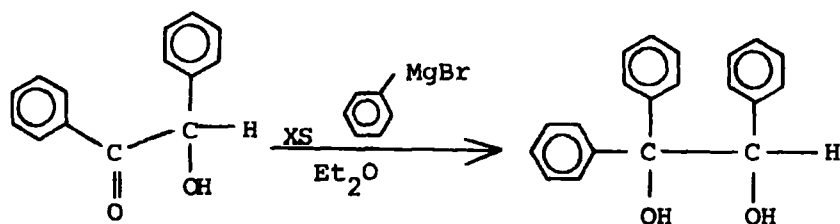
A third investigation was undertaken under the same conditions. This time, however, colourless crystals which formed on the inside wall of the reaction tube were periodically broken by means of a long spatula in order to allow the ultraviolet light to penetrate the solution. After 180 hrs of irradiation a crop of crystals and a viscous bright yellow solution had formed inside the tube. The crystals were separated by filtration and the yellow oil recovered was nitrogen streamed and re-irradiated for a further 120 hrs. The crystals separated were found to consist of a mixture of unreacted benzophenone, benzopinacol, hydrobenzoin and triphenylglycol by t.l.c. on silica (benzene, chloroform). The yellow oil also deposited a fresh crop of crystals during the 120 hrs irradiation period. Examination of these crystals (ca. 1.5g) by i.r. spectroscopy showed the material to be triphenylglycol by comparison with the i.r. spectrum of triphenylglycol obtained by ground state synthesis (see 2.2.e). The yellow oil was found to consist of benzaldehyde, hydrobenzoin and traces of benzopinacol, benzylalcohol and unreacted benzophenone. Attempts to obtain a pure sample of triphenylglycol by repeated recrystallizations from various solvents were largely unsuccessful, since a very faint spot corresponding to benzopinacol was always present on the t.l.c. plates (benzene).

These experiments certainly confirmed the correctness of Ciamician's observations. It would also appear that the formation of triphenylglycol from benzophenone/benzylalcohol is time dependent. The formation of benzaldehyde was also confirmed. Finally, irradiation of an 1:1 molar mixture of benzophenone

and benzylalcohol in benzene solution (0.0035 total concentration) for 160 hrs (350 nm) afforded triphenylglycol in ca. 8% yield.

2.2.e. Ground state syntheses of triphenylglycol

The first attempt to synthesize the above mentioned compound (method A) was based on an established route,¹³⁷ namely the action of benzoin on an excess of phenylmagnesiumbromide. The exercise afforded 60% of nearly pure triphenylglycol. Repeated recrystallizations gave 45% of a white crystalline solid which on examination by t.l.c. on silica was found to be a single compound (Figure 2.38).



(method A)

Figure 2.38

Triphenylglycol was also prepared (method B) by reduction of the corresponding carbonyl compound, α -phenylbenzoin (2,2-diphenyl-2-hydroxyacetophenone), itself prepared by the action of one mole of benzil on one mole of phenylmagnesiumbromide (Figure 2.39).

Pure triphenylglycol (85%) was obtained from this preparation, M.pts and spectroscopic data for the products obtained by the two methods were identical. Elemental analyses were satisfactory. Preparation and purification procedures will be described in more detail in 2.2.j.iii.

2.2.f. The benzophenone/triphenylglycol photoreaction

Following preparation, characterization and rigorous purification of triphenylglycol, it was decided to proceed with the irradiation of a 1:1 molar

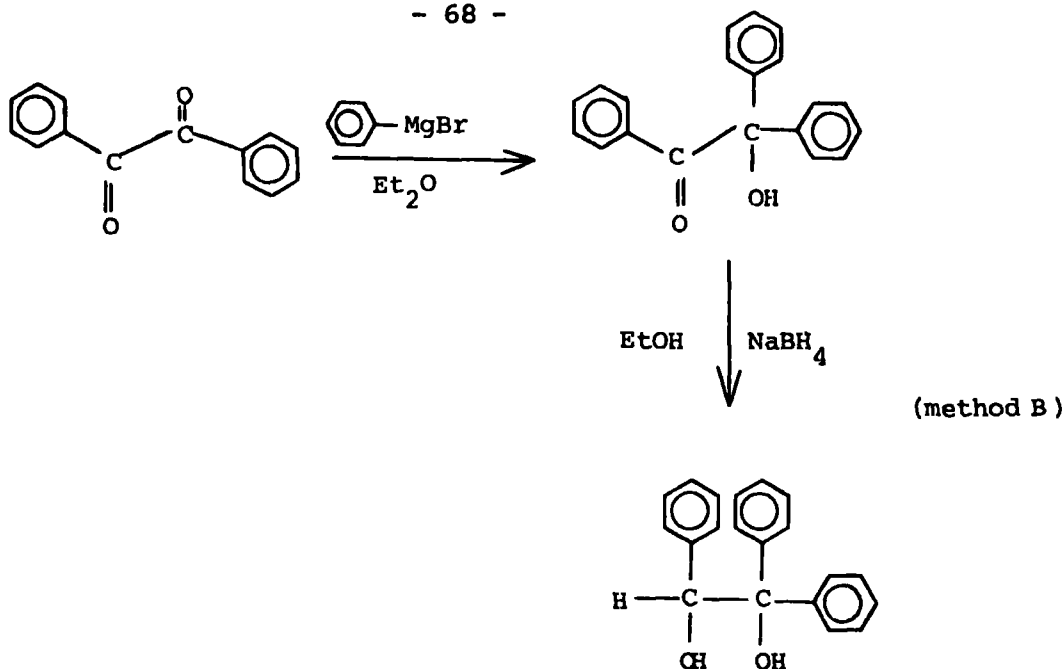


Figure 2.39

ratio of this compound and benzophenone for reasons stated in 2.2.a. Benzene was chosen as an appropriate solvent.

In the first experiment triphenylglycol (2.90g, 0.01 mole) prepared by method A and benzophenone (1.82g, 0.01 mole) were dissolved in benzene (350 mls) in a long Pyrex tube. The clear, colourless solution was nitrogen streamed, the tube was quickly stoppered and irradiated for 18.4 hrs at 350 nm. This experiment yielded unchanged starting materials, as indicated by t.l.c. on silica (benzene, chloroform, ethanol) and i.r. spectral examination.

Repetition of exactly the same reaction using triphenylglycol prepared by method B yielded identical results.

In a subsequent experiment, benzophenone (0.273g, 0.0015 mole) and triphenylglycol (0.435g, 0.0015 mole) prepared by method B were dissolved in benzene (50 mls) in a Pyrex tube. The solution was degassed by several freeze-pump-thaw cycles and tube was sealed under reduced pressure (10^{-3} mmHg). Irradiation for 94 hrs at 350 nm afforded quantitative recovery of starting materials. During this experiment a parallel photoreaction between benzophenone

and benzhydrol (1:1 molar ratio) was carried out in order to test the efficiency of the ultraviolet lamps: benzopinacol was quantitatively obtained after 3 hrs of irradiation.

Repetition of this reaction using triphenylglycol prepared by method A gave the same result.

On the basis of the literature information available on the photoreactions of benzophenone with alcoholic hydrogen donors, one would expect some if not all the processes shown in Figure 2.40 to occur upon irradiation of the benzophenone/triphenylglycol system. The quantitative recovery of starting materials is a surprising result. It seemed remarkable and led to a considerable effort in purifying the triphenylglycol and seeking evidence for the presence of an impurity which could act as an efficient quencher of triplet benzophenone.

Benzene solvent and benzophenone were also exhaustively searched for impurities. Repetitions of the irradiations using more rigorously purified materials made no difference to the result.

One hypothesis considered was that the hydrogen atom transfer illustrated in Figure 2.40 did in fact occur in low yield and that the α -phenylbenzoin formed acted as a quencher in very low concentrations. The hypothesis seemed worth investigating since one could postulate a degenerate isomerization pathway involving a photoenolization and phenyl migration which might have accounted for the postulated quenching (Figure 2.41). The photochemistry of α -phenylbenzoin is not discussed in the literature, despite the very extensive investigations reported on benzoin¹³⁸ in general. When irradiated under the conditions described previously, α -phenylbenzoin proved to be particularly photolabile, both on its own and in the presence of equimolar amounts of benzhydrol.

Finally, the 'quencher theory' was excluded by the irradiation of a nitrogen streamed benzene solution containing a 1:1:1 molar mixture of benzophenone,

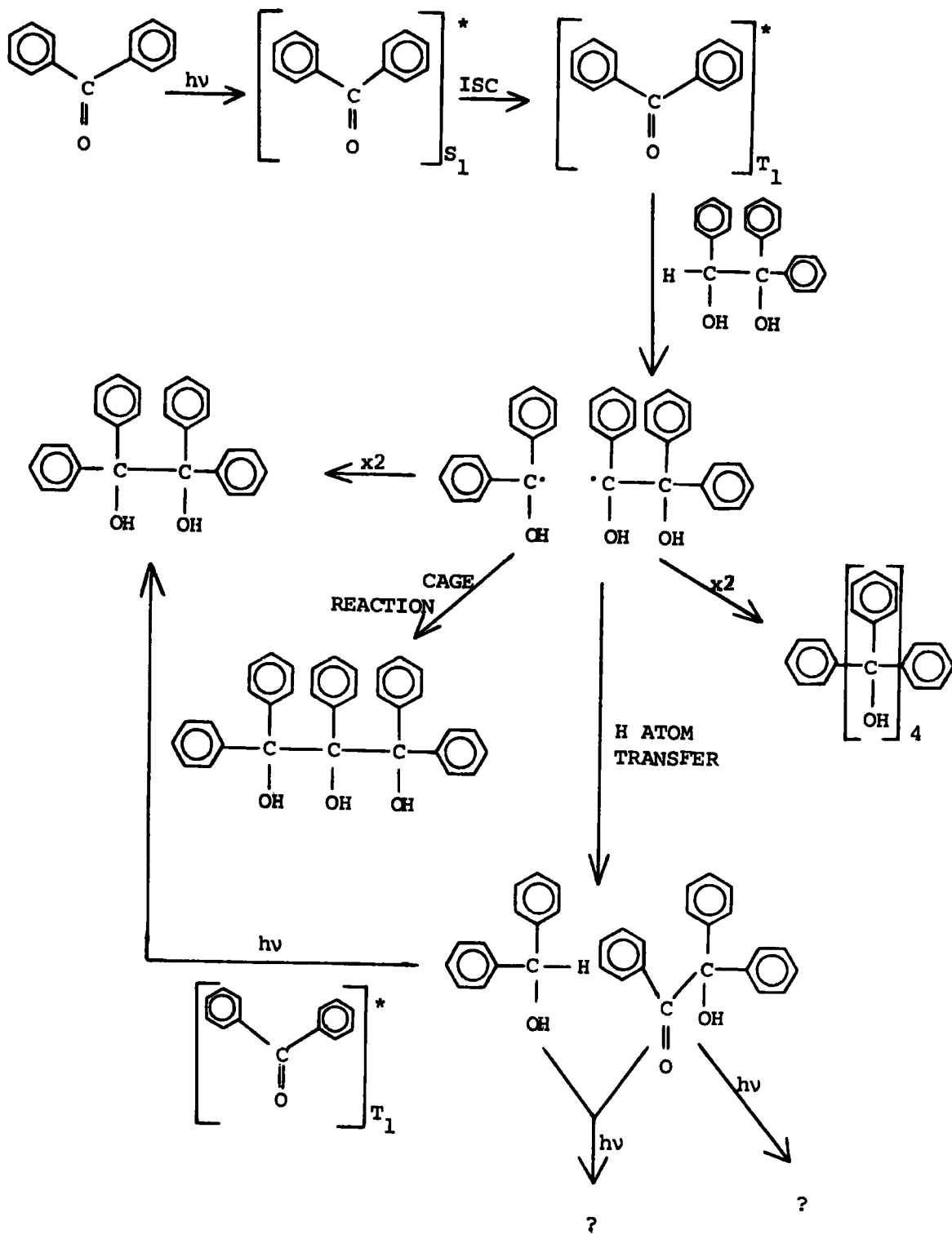


Figure 2.40

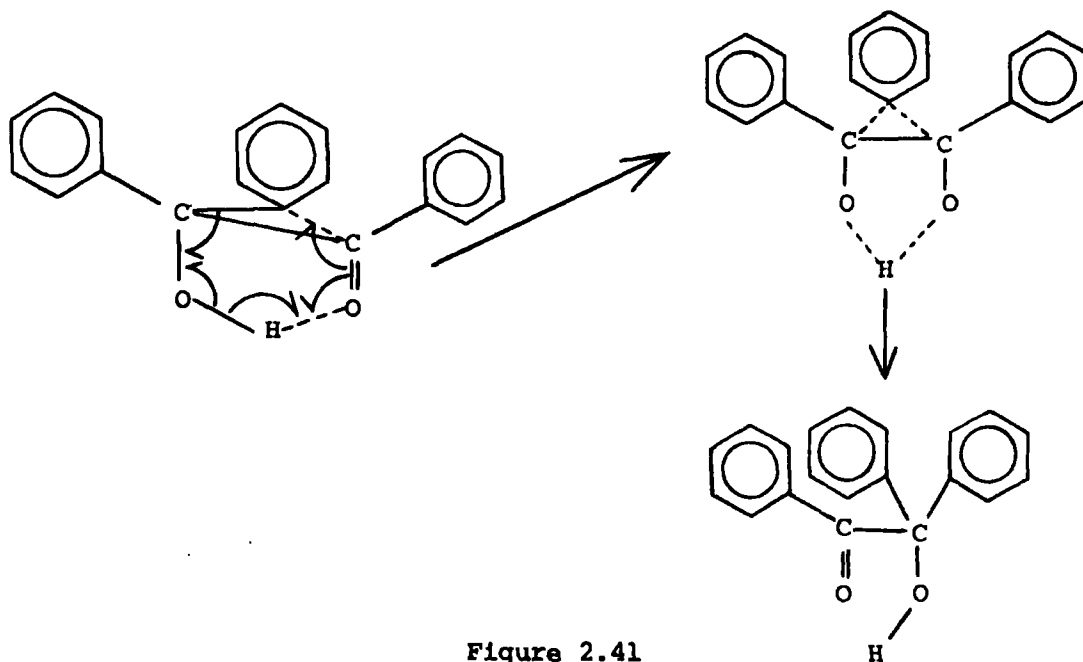


Figure 2.41

benzhydrol and triphenylglycol (0.0035M total concentration) at 350 nm for 12 hrs (Figure 2.42). An 1:1 molar mixture of triphenylglycol and benzopinacol was obtained, benzophenone and benzhydrol having completely disappeared.

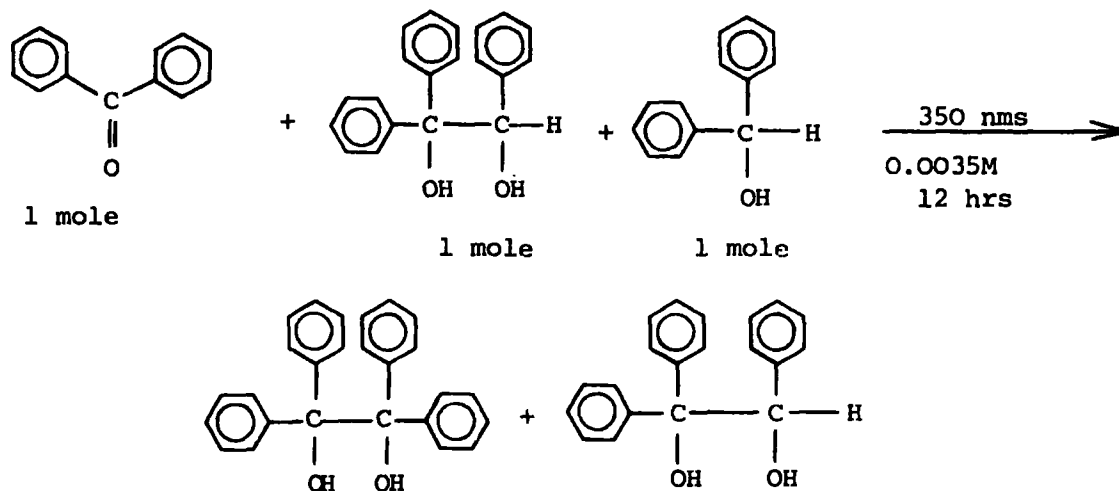


Figure 2.42

This reaction confirmed the observations that the tertiary hydrogen in

triphenylglycol is inert towards abstraction by triplet benzophenone.

2.2.g. The photoreactivity of 1,2,2,2-tetraphenylethanol

The observations described above concerning the photochemical behaviour of triphenylglycol certainly put an end to the hopes of obtaining poly-(pentaphenylglycerol)s by the photoreductive polyaddition of diketones to polyphenylated alcoholic hydrogen donors of the type discussed. The new question which arose was whether the photostability of triphenylglycol was due to the presence of two adjacent C_6H_5COH units next to the tertiary hydrogen, which was expected to be abstractable. In order to test this hypothesis it was decided to substitute the 2-hydroxy group in triphenylglycol with a group of a totally different nature, for instance an aromatic ring, and investigate the photochemical behaviour of the resulting system. To this end 1,2,2,2-tetraphenylethanol (Figure 2.43) was synthesized by reducing benzopinacolone

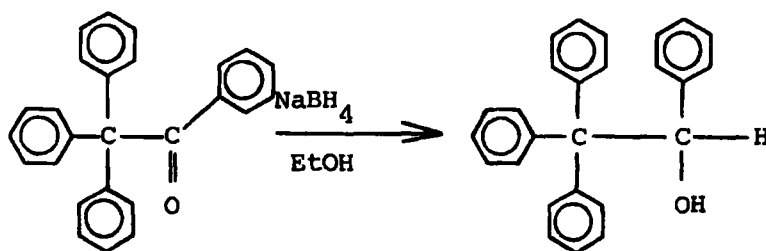


Figure 2.43

and subsequently irradiated with benzophenone (1:1 molar ratio) in benzene solution (0.0056M total concentration) for 12 hrs at 350 nm. Infrared spectroscopic examination and t.l.c. on silica (benzene, chloroform, ethanol) established that no detectable reaction had taken place; starting materials were quantitatively recovered.

As in the case of triphenylglycol, irradiation of a benzene solution containing an 1:1:1 molar mixture of benzophenone, benzhydrol and 1,2,2,2-tetraphenylethanol (0.0035M total concentration) at 350 nm for 24 hrs resulted in the formation of an 1:1 molar mixture of benzopinacol and 1,2,2,2-tetraphenylethanol. No other products were detected by t.l.c. on silica, benzophenone and benzhydrol having disappeared completely.

2.2.h. Some relevant photoreactions

It was so far established that the tertiary hydrogen in the structure shown in Figure 2.44 is abstractable when $X = H$ or C_6H_5 but non-abstractable when $X = (C_6H_5)_2COH$ and $(C_6H_5)_3C$.

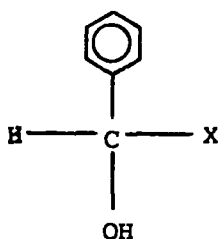


Figure 2.44

In an attempt to examine the possibility of other versions of the system shown being inert to hydrogen abstraction by benzophenone triplet, hydrobenzoin ($X = (C_6H_5)CH(OH)$) and 1-phenylethanol ($X = CH_3$) were irradiated in the presence of either benzophenone or its difunctional analogue, m-dibenzoylbenzene.

Irradiation of a 1:1 molar solution of benzophenone and 1-phenylethanol in benzene (350 nm) resulted in 100% disappearance of both starting materials after 140 hrs of irradiation. Benzopinacol and acetaldehyde were among the reaction products immediately recognized. At least three more products were identified by t.l.c. on silica (benzene).

Irradiation of a 1:1 molar mixture of *m*-dibenzoylbenzene and hydrobenzoin in benzene presented special problems due to the low solubility of the diol. However the portion of it that did dissolve in benzene at 0.0035M total concentration reacted readily with the photoexcited benzophenone-type carbonyl of *m*-dibenzoylbenzene yielding hydroxyl containing materials (350 nm, 160 hrs). Again a bright yellow colour developed shortly after the lamps were turned on. The irradiation was repeated using methylene chloride solvent in order to ensure complete solubility of both starting materials. After only 38 hrs of irradiation solution was again bright yellow and slightly turbid. Examination of the tube contents revealed that some starting materials had been left unchanged but most of them had reacted to give several products as shown by t.l.c. on silica (benzene).

The products from the above reactions were not rigorously examined, the main objective of the exercise being to establish whether photoreaction with benzophenone occurred or not.

2.2.1. Attempts to prepare pentaphenylglycerol via ground state chemistry

Investigations so far revealed that the model reaction for the polymer synthesis formulated in Figure 2.30 does not occur due to a rather surprising inertness of triphenylglycol towards benzophenone triplets. Attempts to further investigate this behaviour led to the discovery of another molecule exhibiting the same remarkable inertness.

At the same time, the preparation of the expected product, pentaphenylglycerol was undertaken via ground state synthesis in order to examine its stability, determine its properties and provide a reference for comparison. The compound is reported in the literature¹³⁹ and the recipe for its preparation given in the original paper was followed in every detail (see Figure 2.45). The original worker reported that pentaphenylglycerol was obtained as a white crystalline solid after a number of recrystallizations (m.pt. 163^o), and that

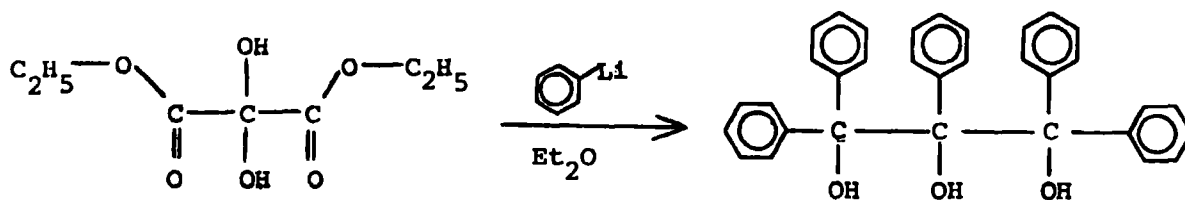


Figure 2.45

its elemental analysis was satisfactory.¹³⁹

In our hands, this reaction gave a white crystalline solid (5g), m.pt. 162° , which, after repeated recrystallizations from methanol and drying under vacuum over P_2O_5 analysed as follows: C 87.54, H 5.64. Calculated figures for pentaphenylglycerol ($\text{C}_{33}\text{H}_{28}\text{O}_3$) are: C 83.33, H. 5.97. This material was found to be a single component by t.l.c. on silica (benzene, ethanol, methanol, acetonitrile). It melted at 164° . Further recrystallizations and drying under vacuum over P_2O_5 for 48 hrs gave a material melting at 164° which analysed as follows: C 87.44, H 5.87. Sublimation (120° , 0.005 mmHg), gave a material identical to the one obtained after recrystallizations (i.r. spectra were superimposable), melting at 164.5° , which analysed: C 87.15, H 6.04. The highest m/e peak observed in the mass spectrum of our product was 260 (molecular weight of pentaphenylglycerol = 472); this was attributed to fragmentation in the mass spectrometer source. The ^1H n.m.r. spectrum showed two peaks, one in the aromatic hydrogen region (δ 7.30) and another at δ 2.73 which disappeared on addition of D_2O . The integrated intensities were in a ratio of 15:1, for pentaphenylglycerol the calculated ratio is 8.33:1. The solid state infrared spectrum of the material (KBr disc) showed a rather

broad OH band at 3465 cm^{-1} , a multiplet in the C-H aromatic region (3020 cm^{-1} - 3080 cm^{-1}) and peaks in the fingerprint region are generally consistent with the product structure proposed in the paper.¹³⁹ However, the solution phase (CCl_4 solvent) of the material showed only one peak at just over 3600 cm^{-1} . Comparative i.r. studies on some phenylated diols and monoalcohols (see Table 2.6) showed that 1,2-diols generally display two peaks in dilute solutions, one above and one below 3600 cm^{-1} , the former being assigned to the free OH stretching and the latter to the intramolecularly bonded OH (Figure 2.46).



Figure 2.46

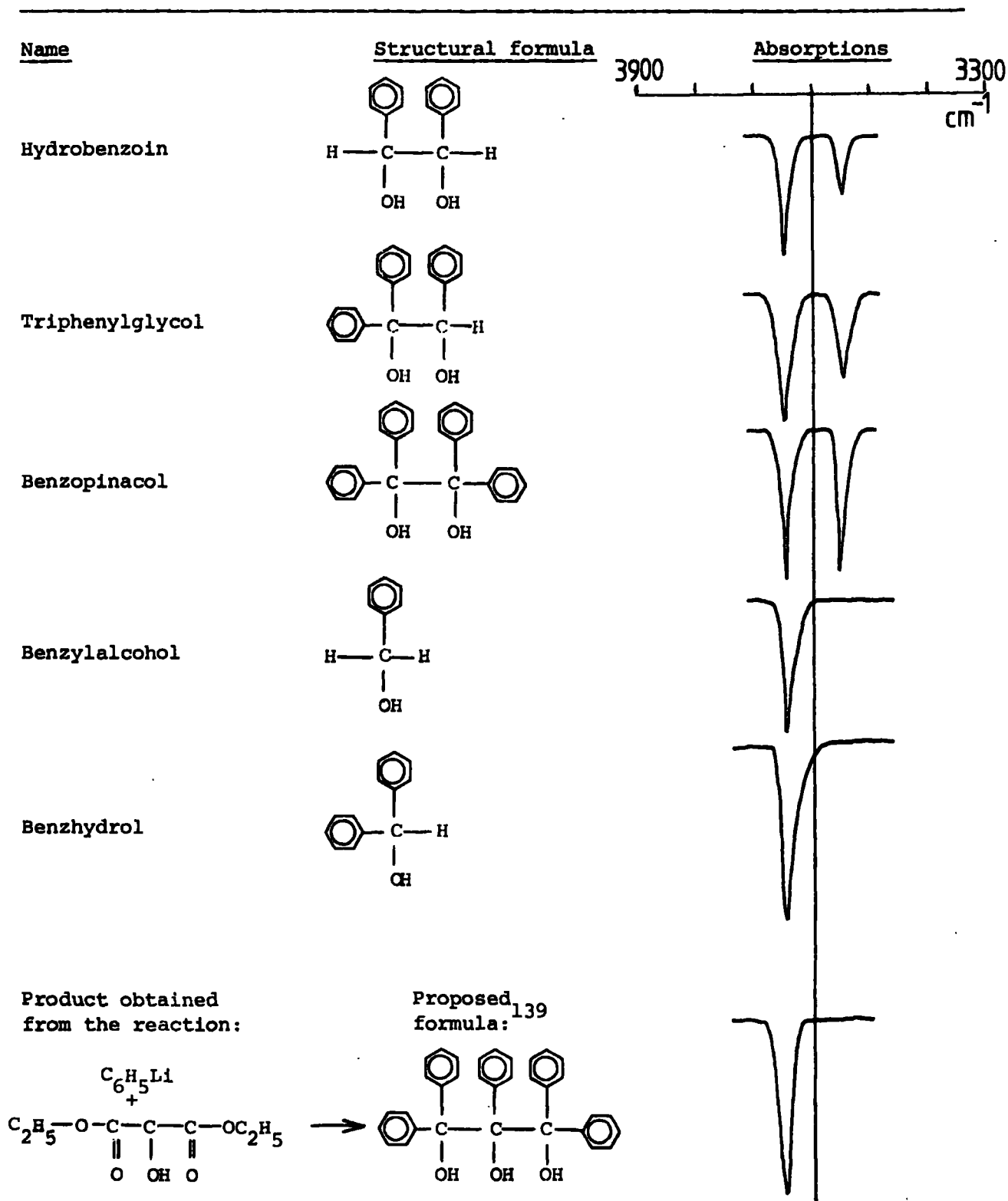
The single OH peak in the solution phase i.r. spectrum indicating the absence of intramolecular hydrogen bonding in the product from the action of phenyllithium on diethyl mesoxalate seemed rather surprising and inconsistent with the formula of pentaphenylglycerol. Furthermore, elemental analysis data and n.m.r. integrated intensity ratios suggested that the product obtained in our hands was not the one claimed in the paper.¹³⁹ This thought led to a systematic search for a compound which could be formed from the above reaction in good yield and be consistent with the data obtained; triphenylcarbinol, $(\text{C}_6\text{H}_5)_3\text{COH}$ looked a promising candidate. Its melting point is reported to be $164^\circ\text{--}165^\circ$;¹⁴⁰ its mass spectrum extends to m/e 260 and calculated elemental analysis figures (C, 87.65; H, 6.19) agree well with those obtained in this

Table 2.6

Comparative solution phase i.r. spectra of some phenylated 1,2-diols and monoalcohols

(OH stretching region, CCl₄ solution, 3mm KBr cell)

Concentration range: 10⁻³M-8 x 10⁻⁴M



work. Further the p.m.r. and i.r. spectroscopic results are in complete accord with the product being triphenylcarbinol. This hypothesis was confirmed by comparison with an authentic specimen. In the original paper,¹³⁹ the following colour test for 'pentaphenylglycerol' was suggested: 'The product from pentaphenylglycerol + acetyl chloride + dimethylaniline in cold for 5 mins was treated with a solution of hydroxylamine and the mixture made alkaline with alcoholic KOH, heated and cooled. A reddish-wine colour was produced on acidification and addition of FeCl_3 solution'. The test was carried out twice on a sample of the reaction product and on a sample of pure triphenylcarbinol. In both cases the same reddish-wine colour was produced. The author has been unable to ascertain the significance attached by the original worker to the colour test, although clearly it is not characteristic of pentaphenylglycerol. Careful repetition of the original recipe gave identical results.

2.2.j. Experimental

2.2.j.i. Readily available materials

Benzylalcohol (technical grade) was purchased from Hopkin & Williams Ltd., and stored over 4A molecular sieves; prior to use it was twice fractionally distilled (15 cm x 4 cm dia., glass helices); the fraction distilling between 205° and 206° was collected (lit.¹⁴⁰ 205.03°/760 mmHg). The product gave a single spot on t.l.c. on silica (chloroform, ethanol, benzene).

Benzhydrol was obtained from departmental stock, recrystallized twice from ethanol/water (70:30) and sublimed twice (95°/0.005 mmHg); the product had a melting point of 69° (lit.¹⁴⁰ 69°) and gave a single spot on t.l.c. on silica (ethanol, benzene, chloroform, toluene, acetonitrile).

Benzophenone (technical grade) was purchased from Hopkin & Williams Ltd. and recrystallized twice from ethanol/water (70:30) and once from cyclohexane, melting at 48.5° (lit.¹⁴⁰ 49°). It gave a single spot on t.l.c. on silica (benzene, ethanol, chloroform, acetonitrile, toluene, ethylacetate, carbon tetrachloride, acetone/water 50:50).

1-Phenyl ethanol (technical grade) was purchased from BDH Laboratory Reagents and stored over 4A molecular sieves; prior to use it was distilled twice under reduced pressure (15 cm x 4 cm dia., glass helices, 98°-100°/20 mmHg, lit.¹⁴⁰ 98°-99°/20 mmHg). The product gave a single peak on analytical g.l.c. (col. 'A'/140°).

Diethyl ketomalonate (C₂H₅OCOCOCOC₂H₅) was purchased from Aldrich Chemicals, and used as obtained without purification. Its m.s. and i.r. spectrum were consistent with the assigned structure.

Benzoin, benzil and benzopinacolone were all obtained from departmental stock, recrystallized twice from appropriate solvents, dried under vacuum and identified by infrared spectroscopy (KBr discs) and melting point determinations. Purities were checked by t.l.c. on silica (benzene).

Sodium borohydride was purchased from BDH Laboratory Reagents and used as obtained.

2.2.j.ii. Solvents

Benzene (analytical grade) was purchased from Hopkin & Williams Ltd., twice fractionally distilled (15 cm x 4 cm dia., Dixon gauzes) and stored over sodium wire for two weeks. Prior to use it was redistilled under nitrogen into a dry flask. Analytical g.l.c. indicated a single component (col. 'A'/60°).

Methylene chloride (technical grade) was obtained from departmental stock, fractionated twice (40°-42°) and stored over anhydrous magnesium sulphate for two days. It was redistilled under nitrogen (41°) before use.

Ethanol and 1,4-dioxane were obtained from departmental stock and used without purification.

2.2.j.iii. Materials synthesized from simpler chemicals

Synthesis of hydrobenzoin from benzoin

Sodium borohydride (2.7g, 0.072 mole) in water (50 mls) was added to a solution of benzoin (15.0g, 0.072 mole) in 1,4-dioxane (200 mls) contained in a conical flask and the mixture was boiled (20 mins). Following destruction of unreacted NaBH_4 with dilute CH_3COOH and evaporation of the solution, a white solid was obtained which was washed with water and recrystallized twice (ethanol/water 60:40) to give hydrobenzoin (12.1g, 80%), m.pt. 147°-148° (lit.¹⁴⁰ 149°-150°), identified by mass spectrometry (correct molecular ion at m/e 214 and expected fragment ions) and infrared spectroscopy. The substance was recrystallized three more times from the same solvent and finally from a large volume of ethanol/water (80:20); m.pt. 147.5° (big plates, single spot on t.l.c. on silica).

Synthesis of m-dibenzoylbenzene

m-Dibenzoylbenzene was initially prepared according to the published route.⁶⁰

To a stirred solution of isophthaloyl chloride (50g, 0.246 mole) in dry benzene (400 mls), anhydrous aluminium chloride (80g, 0.60 mole) was added in small portions (ca. 60 mins). The solution was refluxed for 2 hrs, cooled and hydrolysed by pouring into 10% HCl/ice water solution (3 litres). After evaporation of benzene, the resulting crude material was recovered by filtration and washed successively with a 5% aqueous solution of sodium carbonate, a 5% aqueous solution of HCl and water prior to recrystallization from cyclohexane. Repeated recrystallization (20 to 25 times) afforded a material giving a single spot on t.l.c. on silica (acetone, chloroform, benzene, ethanol, acetonitrile, methanol, toluene). The yield of pure material was just under 21%; m.pt. 103° - 104° (lit.⁶⁰ 109° - 110°). The product had the correct m.s. and i.r. spectrum.

The unsatisfactory yield obtained by the above procedure to a more detailed investigation of this reaction. Analysis of the reaction by-products by t.l.c. (benzene, chloroform) revealed the presence of low mobility substances (possible polymeric materials), some unidentified products, and isophthalic acid. The latter must have resulted from the hydrolysis of unreacted isophthaloyl chloride. In one preparation using the procedure given above it was possible to isolate ca. 10g of isophthalic acid from the reaction liquors by treatment with aqueous potassium carbonate and subsequent acidification of the aqueous layer.

In an attempt to improve the yield of the reaction, the following modified procedure was used: doubly distilled isophthaloyl chloride (200g) were dissolved in sodium dried benzene (2000 mls) with vigorous stirring. Finely ground anhydrous aluminium chloride (400g) was added in smaller portions than in the previous method over a longer period of time (ca. 6 hrs); when the addition was complete, the mixture was stirred at room temperature for 6 hrs and then refluxed for another 6 hrs. Following hydrolysis of the mixture, organic

materials were extracted with benzene (2 x 1000 mls) and the extracts boiled three times with activated animal charcoal. The colourless solution obtained was evaporated and the recovered white solid was recrystallized three times from cyclohexane to give pure m-dibenzoylbenzene (196g, 70%) as shown by t.l.c. on silica using a variety of eluents. This product had the correct m.s. and i.r. spectrum, m.pt. 103° - 104° , and elemental analysis (found C, 83.68; H, 5.29; calculated for $C_{20}H_{14}O_2$ C, 83.90; H, 4.93).

A small sample of the purified m-dibenzoylbenzene was dissolved in a large volume of boiling cyclohexane, and the solution was left to cool slowly over a period of several days. Large prisms of material, some of them nearly 2.5 cm long were obtained, having a very sharp melting point of 103.8° .

Preparation of 1,2,2,2-tetraphenylethanol

To a solution of benzopinacolone (3.48g, 0.01 mole) in ethanol (100 mls) a solution of sodium borohydride (0.38g, 0.01 mole) in water was slowly added. After frothing had subsided, the mixture was refluxed for 2 hrs. Addition of 2 litres of water caused the precipitation of a white powdery material which was recovered by filtration, washed with copious amounts of water, recrystallized from 50:50 methanol/water and dried under vacuum to give 1,2,2,2-tetraphenylethanol (2.8g, 80%), m.pt. 150° (lit. 140° 151°); found C, 88.89; H, 6.20; calculated for $C_{26}H_{22}O$: C, 89.14; H, 6.29. The material gave a single spot on t.l.c. on silica (benzene, chloroform, ethanol, methanol). The mass spectrum showed no molecular ion, the highest peak being at m/e 332 (molecular ion-18); the other main peaks were at 224, 243, 182, 167, 165, 152, 105, 77. The infrared spectrum of the recrystallized product (nujol mull) showed a triplet of peaks in the OH stretching region, 3600 (strong-sharp), 3540 (weak-sharp), ca. 3450 (broad-very weak) cm^{-1} . The product was re-purified by sublimation at $140^{\circ}/0.005$ mmHg; the infrared spectrum of this product (m.pt. 151.5°) showed a quartet of peaks in the OH stretching region at 3590 (strong-sharp),

3560 (weak-sharp), 3540 (medium-sharp), 3450 (medium-broad) cm^{-1} , in addition to peaks at $\bar{\nu}_{\text{max}}$: 3080, 3050, 3020, 2960, 2920, 1590, 1490, 1445, 1045, 1030, 705 cm^{-1} , (spectrum recorded as KBr disc). In an attempt to ensure the complete dryness of the product, a benzene solution of a sample of the sublimed 1,2,2,2-tetraphenylethanol was refluxed in a Dean-Stark apparatus; there was no change in the infrared spectrum or the m.pt. of the recovered sample.

A further surprising result was obtained when the solution phase infrared spectrum of the substance was examined under the conditions specified in Table 2.6. A doublet of peaks was obtained, similar to the ones obtained for 1,2-diols in the OH stretching region, possibly indicating the existence of some degree of intermolecular hydrogen bonding in an associated dimer.

Preparation of α -phenylbenzoin

A saturated solution of benzil (16g) in ether was slowly added (30 mins) to a stirred ether solution (200 mls) of phenylmagnesiumbromide (from 15g bromobenzene) at 0° . The resulting solution was refluxed for 30 mins, then hydrolysed by pouring into 1 litre 10% HCl/ice water mixture. A brown viscous mass was obtained which was treated several times with ethanol to give a whitish powder (65%); this was recrystallized several times from ethanol/water (70:30) giving α -phenylbenzoin (50%), a white crystalline solid m.pt. 87° (lit. $^{140} 88^\circ$); found: C, 83.89; H, 5.95; calculated for $\text{C}_{20}\text{H}_{16}\text{O}_2$: C, 83.31; H, 5.59. This material gave a single spot on t.l.c. on silica (benzene, chloroform, ethanol, acetone/water, acetonitrile). The product was further purified by sublimation ($90^\circ/0.005$ mmHg); the sublimed material melted at 88.8° . The mass spectrum showed no molecular ion the highest peak being m/e 184 with prominent peaks at m/e 183, 151, 106, 105, 77; clearly there is extensive fragmentation in the source. The u.v. spectrum in cyclohexane revealed three peaks at 350 (38), 347 (84), and 317 (258) nm (ϵ) in addition to strong aromatic bands. The i.r. spectrum (KBr disc) showed $\bar{\nu}_{\text{max}}$: 3500,

3050, 3040, 1675, 1600, 1580, 1500, 1450, 1350, 1250, 1185, 1030, 850, 700 (doublet) cm^{-1} . The n.m.r. spectrum showed a multiplet in the aromatic proton region at δ 7.7(15) and a singlet at δ 4.91(1) which disappeared on addition of D_2O assigned to the hydroxyl group.

Preparation of Triphenylglycol

Method A:¹³⁷ Finely ground benzoin (21.2g, 0.1 mole) was slowly added to a vigorously stirred ether solution of phenylmagnesiumbromide (from 55g bromobenzene). Addition, over a period of 1 hr, was carried out at 20° , the resulting mixture was stirred for 5 hrs at room temperature and then gently refluxed for 6 hrs; it was then hydrolysed by pouring into 5% HCl/ice water mixture. A powdery product was obtained in 60% yield which, after repeated recrystallizations from ethanol yielded pure triphenylglycol (45%), m.pt. 165° (lit.^{128,129} 168° , 164°).

Method B: A solution of sodium borohydride (0.01 mole) in water was slowly added to a stirred solution of α -phenylbenzoin (0.01 mole) in ethanol (150 mls). After initial vigorous frothing had subsided, the mixture was refluxed for 3 hrs. A white material precipitated on addition of 1 litre of water; it was recovered by filtration, washed with water, recrystallized from ethanol/water (70:30) and dried under vacuum to give triphenylglycol (85%), m.pt. 166° .

Materials obtained by both methods gave, after repeated recrystallizations from ethanol/water (70:30), single spots on t.l.c. on silica (benzene, toluene, chloroform, acetonitrile, methanol, acetone/water, ethanol, carbon tetrachloride, ethylacetate, chloroform/carbon tetrachloride). Elemental analyses were as follows: method A: C, 82.91; H, 5.94; method B: C, 82.73; H, 6.25; calculated for $\text{C}_{20}\text{H}_{18}\text{O}_2$: C, 82.38; H, 6.44. Both samples displayed the same spectral characteristics. The infrared spectrum (KBr disc) showed $\bar{\nu}_{\text{max}}$: 3570, 3470, 3090, 3070, 3040, 2940, 1500, 1450, 1190, 1065, 1045, 1030, 900, 760, 750, 700, 620 (doublet).

The ^1H n.m.r. spectrum ($\text{CDCl}_3/\text{CD}_3\text{COCD}_3$, TMS ext. ref.) showed a multiplet at δ 7.7(15), doublets at δ 5.59 ($J = 4$ Hz, 1) and δ 4.04 ($J = 4$ Hz, 1), and a singlet at δ 3.88(1); the signals at δ 4.04 and 3.88 disappeared on addition of D_2O allowing their assignment as hydroxyl protons attached to the secondary and tertiary carbons respectively.

Sublimation of triphenylglycol ($130^\circ/0.005$ mmHg) afforded a material (m.pt. 166.8°) whose i.r. spectrum in the solid state (KBr disc) displayed 3 peaks in the OH stretching region ($\bar{\nu}_{\text{max}}$: 3560, 3520, 3460 cm^{-1}) and 2 peaks in the C-H aliphatic stretching region ($\bar{\nu}_{\text{max}}$: 2930, 2890 cm^{-1}). There were also some minor differences in the fingerprint region of the spectrum. Elemental analysis figures, and ^1H n.m.r. spectrum of the sublimed were not different from those of the recrystallized material. The substance gave a single spot on t.l.c. on silica (benzene, chloroform, ethanol, acetonitrile). The solution phase infrared spectrum of the sublimed material in the OH stretching region (CCl_4 solvent - see Table 2.6) was the same as the one for the recrystallized material.

2.2.k. Discussion and Conclusions

The basic question asked in this Section, as already set out in 2.2.a was: 'Can poly(pentaphenylglycerols) and higher analogues of structure shown in Figure 2.30 be prepared by the photoreductive addition of aromatic diketones to suitable alcoholic hydrogen donors?'. This question was answered in 2.2.f. where it was established that the model reaction illustrated in Figure 2.47 is limited to the case where $m = 1$, benzopinacol being quantitatively obtained; when $m = 2$ reaction does not afford any detectable products. Cases where $m > 2$ have not been examined, partly in view of the absence of reports on such compounds in the literature and partly due to the doubts on the possibility of their existence arising from the failure to isolate pentaphenylglycerol from the reaction described in 2.2.i.

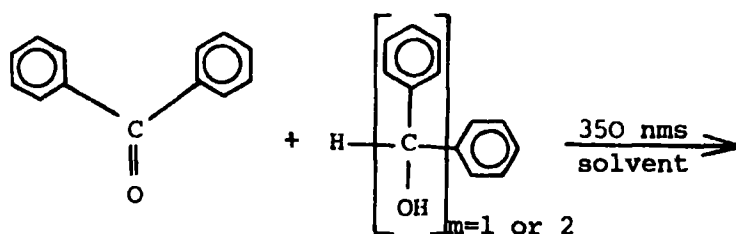


Figure 2.47

The failure of the model reaction (Figure 2.47, $m = 2$) to proceed leads to the conclusion that the photoreductive polymerization of diketones cannot be extended beyond the polybenzopinacol stage, in other words this type of polymerization cannot be applied to the synthesis of structures of the kind shown in Figure 1.12.

Although the question regarding the synthesis of poly(pentaphenylglycerols) and higher analogues was answered, some new questions have been uncovered:

a) The old dispute between Ciamician and Paternò regarding the formation of triphenylglycol was resolved in favour of Ciamician (2.2.d). However, when the reaction was repeated by us a bright yellow colour was observed after a few hours of ultraviolet irradiation, indicating the formation of an intermediate. By analogy to the benzophenone/isopropanol and benzophenone/ethanol photoreductions (see 2.1.b) it seems probable that this is a species of the type shown in Figure 2.48. Such a species might act as an internal light filter and this would account for the slow reaction rate observed and the failure of the reaction to go into completion even after 300 hrs of irradiation (see 2.2.d). Alternatively, one could attribute the bright yellow colour to the photolysis of benzaldehyde, itself a product of the benzylalcohol/benzophenone photoreaction; photolysis of neat colourless benzaldehyde was

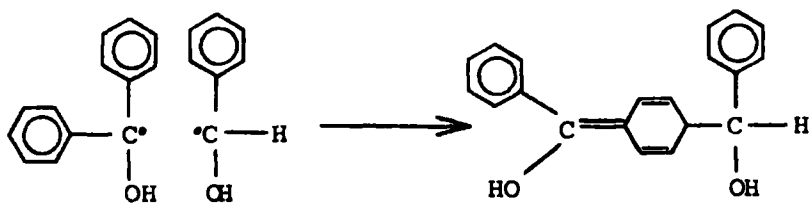


Figure 2.48

found to yield yellow coloured materials (see Chapter 3).

A bright yellow colour was also observed in the photoreactions of *m*-dibenzoylbenzene/hydrobenzoin mixtures and benzophenone/1-phenylethanol mixtures (2.2.g). Again, one could postulate the formation of similar coloured intermediates as shown in Figure 2.49. However, the origin of the yellow

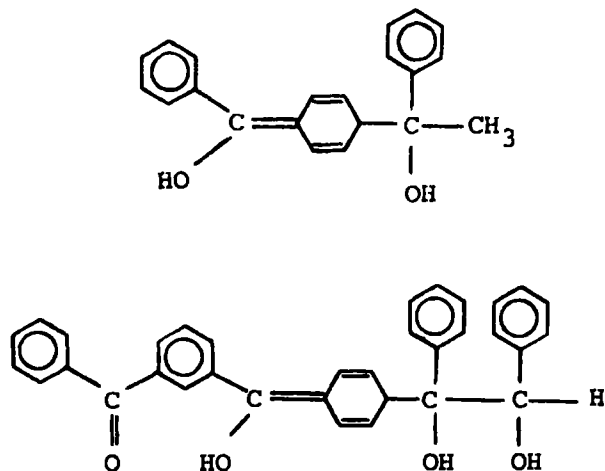


Figure 2.49

colour has not been rigorously examined and the nature of the intermediates involved is open to question.

β) The inertness of triphenylglycol and 1,2,2,2-tetraphenylethanol towards benzophenone triplet is another question not easy to deal with. In 2.1.b.vi the steric effect on photoreduction was examined and some examples were given showing that steric hindrance can be important. Comparative molecular model studies of the compounds examined here have shown that for both structures the tertiary hydrogen, which was expected to be abstractable, appears to be only marginally more hindered than the tertiary hydrogen in benzhydrol or hydrobenzoin. In our view, it seems unlikely that the complete lack of reactivity exhibited by these compounds can be accounted for by steric hindrance; on the other hand, the C-C σ bond separating the $(\text{OH})\text{HC}(\text{C}_6\text{H}_5)$ group from the $(\text{C}_6\text{H}_5)_2\text{COH}$ group (in triphenylglycol) and the $(\text{C}_6\text{H}_5)_3\text{C}$ group (in 1,2,2,2-tetraphenylethanol) should rule out any electronic interactions between the groups, at least of the type known and understood by us. Finally, the 'quencher theory' having been ruled out (see 2.2.f), we are left with no explanation to suggest for these observations.

Other authors have commented on the unexpected selectivity of the benzophenone triplet in hydrogen abstraction reactions. Thus, although it is well established that hydrogen abstraction occurs readily from toluene and diphenylmethane it has been reported that the tertiary hydrogen of triphenylmethane is not abstractable.⁹⁷ In the case of these three hydrocarbons it is not difficult to construct a rationalization of these observations in terms of steric hindrance. On the other hand if steric effects are controlling the abstractability of the tertiary hydrogens in benzhydrol, hydrobenzoin, triphenylglycol and tetraphenylethanol the effects depend on rather subtle differences which are not readily detected by examination of space filling molecular models.

γ) The failure to isolate pentaphenylglycerol or detect high molecular weight products from the reaction between diethyl mesoxalate and excess of phenyllithium is another problem which arose during the course of these

investigations. Evidence presented in section 2.2.1 tends to suggest that the original claim to have synthesized pentaphenylglycerol¹³⁹ was erroneous. The original author's only evidence, apart from the 'colour test' which has been shown to be meaningless, is the good agreement found and calculated analytical figures. However, the occlusion of methanol solvent in the molecule due to inadequate drying might have lowered elemental analysis figures, leading to the wrong conclusions.

The formation of triphenylcarbinol from the reaction of a large excess of phenyllithium with diethyl ketomalonate is not inherently unreasonable and it is interesting to note that the product yield obtained in this work and by the original author corresponds to the formation of a third of a mole of carbinol for each diethyl ketomalonate consumed. A detailed study of this reaction was not undertaken; however if it is assumed that the initial attack of phenyllithium takes place at the central ketogroup and is followed by elimination of carbon monoxide and ethoxide anion, the beginnings of a possible rationalization can be constructed. Although it may be that pentaphenylglycerol is inherently unstable and fragmented as fast as it is formed; this would be surprising since examination of space filling models would not lead one to suspect that the compound is significantly more sterically hindered than, say, benzopinacol. However, the observation that benzopinacol gives radicals by C-C bond homolysis under mild conditions¹¹⁸ may be quoted in support of the postulated instability of pentaphenylglycerol.

δ) Finally the difference in the solid state infrared spectrum between recrystallized and sublimed triphenylglycol, and the unexpected exhibition of a doublet of peaks in the OH stretching region by 1,2,2,2-tetraphenylethanol in CCl₄ solution (see 2.2.j.iii) are further questions which remain unanswered.

2.3. Use of the diphenylmethane-benzophenone reaction as the polymer building step

2.3.a. Details of model reactions

2.3.a.i. Discussion of literature

The diphenylmethane-benzophenone photoreaction was first investigated by Paternò and Chieffi almost 60 years ago.¹¹⁹ Their experiment consisted of insolating 20g (0.109 mole) of benzophenone and 25g (0.148 mole) of diphenylmethane in a sealed tube. Such a mixture constitutes a liquid mass at ambient temperature, so the authors found it more convenient not to use a solvent. Hard crystals were observed forming on the inside wall of the tube after only two days of insolation; they were separated after ten days and the remaining solution was insolated again until reaction was complete.

The solid material obtained was dissolved in boiling benzene and an 'almost pure' novel compound crystallized on cooling. Examination of the recrystallization solvent revealed the presence of traces of the novel compound and the excess of diphenylmethane. No other materials were identified.

In order to make sure that the solid material obtained from the insolation was in fact pure, the authors treated it successively with the following hot solvents: ethanol, 'acetic ether', 'acetic acid', 'acetic ether' again and finally benzene, still leaving an insoluble portion ['acetic ether' is the literal translation, we think this was probably ethylacetate]. All the samples thus obtained melted at 212°-214°. The novel compound was found to be only slightly soluble in the above solvents (in cold) and also in diethylether, chloroform, carbon disulphide, p-xylene, fused phenol, fused thymol etc. It was found to be soluble in hot solvents giving large, well defined needles on cooling. The results of elemental analysis and ebullioscopic molecular weight determination in ethanol and benzene were in good agreement with the values calculated for C₂₆H₂₂O, the 1:1 addition product.

Treatment of the product with P₂O₅ in xylene afforded tetraphenylethylene, identified by means of elemental analysis and m.pt. determination. Treatment with phosphorous and iodine afforded tetraphenylethane similarly identified.

On the basis of the above evidence the authors assigned to the product the structure of 1,1,2,2-tetraphenylethanol.¹¹⁹

The compound was further studied by Bergmann and Engel¹⁴¹ who isolated two forms of it, one melting at 235° (α) and another melting at 216° (β), the latter prepared by the insolation of the benzophenone-diphenylmethane mixture. They attributed this phenomenon to isomerism of 1,1,2,2-tetraphenylethanol, resulting from inability of the $(C_6H_5)_2COH$ and $(C_6H_5)_2CH$ groups present in the molecule to rotate freely about the ethane C-C bond.¹⁴¹

Wegler¹⁴² re-investigated the insolation experiment and obtained a product which, after three recrystallizations from acetone melted at 215°-217°. Attempts to replace the OH group by chlorine never gave halogenated derivatives, and only after repeated recrystallizations was a homogeneous product obtained, identified as tetraphenylethylene. By repeating the recrystallization of the photochemically prepared 1,1,2,2-tetraphenylethanol fifteen times, its m.pt. was raised to 229°. The same result was obtained when treatment with the solvent was carried out in cold, so the author concluded that his results could not be interpreted as the β -form being rearranged to the α -form. When the β -form was heated for several hours in pyridine at 135°, its melting point was lowered somewhat and recrystallization of the product yielded the α -form. Wegler concluded that the β -form was impure α and that heating with pyridine changed the impurities to materials readily removed by subsequent recrystallization. The author considered the reported cases of benzophenone photoreduction in the presence of aliphatic and aromatic hydrocarbons, where benzopinacol and the dimerized hydrocarbons are formed and concluded that impurities in the β -form were probably benzopinacol and tetraphenylethane. He then prepared an artificial mixture of α and 20% benzopinacol and tetraphenylethane and claimed that it behaved exactly like the so-called β -form. He attributed the easy purification of the β -form by boiling it in pyridine to the decomposition of benzopinacol present into benzophenone and benzhydrol

which could then be easily removed by recrystallization. When the α -form was treated with sodium in benzene, $\text{CH}_2(\text{C}_6\text{H}_5)_2$, $(\text{C}_6\text{H}_5)_2\text{CO}$, $(\text{C}_6\text{H}_5)_2\text{CHOH}$, $\text{C}_6\text{H}_5\text{COOH}$ and predominantly $(\text{C}_6\text{H}_5)_2\text{C} = \text{C}(\text{C}_6\text{H}_5)_2$ were obtained, whereas treatment of the β -form with boiling benzene in the presence of sodium gave an intense blue-green colour attributed by the author¹⁴² to the presence of benzopinacol.

In the same year that Wegler published his results, 1,1,2,2-tetraphenylethanol was independently prepared by Richard via ground state synthesis and its melting point was determined to be 236.5° .¹⁴³ Three years earlier the same compound was prepared by the action of phenylmagnesiumbromide on α, α -diphenylacetophenone and the reported melting point was 232° - 233° .¹⁴⁴ In 1937, a similar reaction, namely the action of phenylmagnesiumbromide on $\text{C}_6\text{H}_5\text{CHClCOCl}$ afforded 1,1,2,2-tetraphenylethanol melting at 232.5° - 233° .¹⁴⁵

1,1,2,2-Tetraphenylethanol was also obtained in low yield by boiling benzopinacol in cyclohexanone; this sample had a m.pt. of 232° - 233° .¹⁴⁶ The following year the same author reported the repetition of the benzophenone-diphenylmethane insolation experiment initially performed by Paternò and Chieffi;¹¹⁹ he obtained a product which, after recrystallizations, melted at 217° - 218° on a copper block whereas m.pt. determination using a Kofler apparatus caused sublimation to minute needles which became opaque at 230° - 232° and melted sharply at 243° - 244° .¹⁴⁷ Further studies of the photochemical reaction by Banchetti¹⁴⁷ yielded a product which melted at 206° - 210° ; treatment of the product with a large volume of acetone yielded a compound melting at 217° - 218° . Considerable reduction in the volume of acetone yielded small amounts of benzopinacol, identified on the basis of its 'behaviour under the microscope'.¹⁴⁷ Further recrystallization of 1,1,2,2-tetraphenylethanol from acetic acid caused a rise in the melting point to 223° - 224° whereas recrystallization from acetic anhydride yielded a material melting at 227° - 228° . Finally, boiling the material in cyclohexanol for one hour and

recrystallization of the nearly pure material thus obtained from chloroform-acetone and then chloroform-ethanol yielded a product melting at 244° .¹⁴⁷ Having satisfied himself on the question of the purity of 1,1,2,2-tetraphenylethanol thus obtained, and having established the formation of benzopinacol from the photochemical experiment, Banchetti did not investigate the possible formation of any other by-products. He concluded¹⁴⁷ that the best way to obtain 1,1,2,2-tetraphenylethanol in high yield was the insolation of the benzophenone-diphenylmethane mixture; purification of the material from the last traces of benzopinacol (itself a low yield by-product of the photoreaction) necessitated however heating the ethanol with a high boiling solvent - preferably cyclohexanol - followed by recrystallization. This method afforded a non-specified high yield of pure material melting at 244° .¹⁴⁷

Another preparation of the ethanol appeared in the literature in 1956:¹⁴⁸ treatment of 0.01 mole of the ketoester $C_6H_5C(O)-CH(C_6H_5)-O-C(O)CH_3$ in diethylether with 0.01 mole phenylmagnesiumbromide, refluxing for 30 mins, cooling, adding another 0.05 mole phenylmagnesiumbromide during 40 mins and refluxing for 15 mins gave after evaporation of diethylether solvent and purification from chloroform 38% pure 1,1,2,2-tetraphenylethanol. The melting point of the compound was however reported to be $231^{\circ}-232.5^{\circ}$.¹⁴⁸ A few years later a group of American workers obtained 1,1,2,2-tetraphenylethanol by the addition reaction of sodium diphenylmethide with benzophenone in liquid ammonia solvent followed by recrystallization from methylene chloride; 86% of pure compound were obtained, melting at $243^{\circ}-244^{\circ}$.¹⁴⁹

The literature in this area already presents a rather confused picture, it was therefore necessary to re-examine the photoreaction of benzophenone with diphenylmethane before proceeding to the proposed polymerization of bifunctional monomers. Results of this re-examination are presented in the next section and the literature claims reviewed thereafter.

2.3.a.ii. Experimental Results

a) Irradiations without solvent

A 1:1 molar mixture of benzophenone and diphenylmethane (starting with 15g benzophenone) forming a homogeneous liquid mass was transferred into a cylindrical Pyrex tube and nitrogen streamed for $\frac{1}{2}$ hr. The tube was quickly stoppered and irradiated at 350 nm (ca. 40°). After 30 hrs of irradiation the inside walls of the tube were covered with a thick layer of colourless crystals and remaining solution was bright yellow. The tube was opened, crystals were broken by means of a long spatula and left as a solid precipitate at the bottom of the tube. The solution was nitrogen streamed again for $\frac{1}{2}$ hr and re-irradiated for another 60 hrs. Again colourless crystals had formed in the inside wall of the tube. Following opening of the tube, destruction of the crystalline layer, nitrogen streaming and stoppering, solution was re-irradiated for a further 14 hr period; a new layer of crystals had formed and yellow colour appeared somewhat more intense. At that stage the tube was opened, the crystals were filtered off and the bright yellow solution obtained was nitrogen streamed and re-irradiated for 29 hrs yielding another layer of hard colourless crystals. At that point the reaction was stopped, the crystals were filtered off, combined with the crop obtained from the previous filtration and dissolved in boiling benzene. Slow cooling of the benzene solution yielded 17.3g (ca. 60%) of a white crystalline material in well defined needles. Examination of the needles by t.l.c. on silica (benzene) revealed the presence of one component only, whereas examination of the yellow solution revealed the presence of the same material and also benzophenone and diphenylmethane. Examination of the recrystallization solvent by the same method revealed the presence of the crystalline material, benzophenone and diphenylmethane. No benzopinacol was detected. Melting point of the crystals obtained was found to be

228^o-229^o. Subsequent recrystallizations from chloroform caused only a very small rise in the melting point, not exceeding 2^o.

The same reaction was attempted using a 20% excess of diphenylmethane. This time however colourless crystals formed in the inside wall of the tube were not broken but were left to accumulate. After 130 hrs or irradiation a bright yellow colour was observed inside the tube. Working-up the reaction products as before afforded ca. 40% of the white crystalline solid which, after recrystallizations from benzene and chloroform was found to melt at 229^o-230^o. Examination of the white solid, yellow solution and recrystallization solvents by t.l.c. on silica (benzene, chloroform) failed again to reveal the presence of benzopinacol or other by-products. Boiling the white crystalline material in pyridine for 1.5 hrs, precipitation with water and recrystallization of the product thus obtained from benzene large crystals (70%), m.pt. 231^o.

β) Photoreactions in benzene solvent

An 1:1 molar mixture of benzophenone and diphenylmethane (starting with 10g benzophenone) was dissolved in benzene (0.01M with respect to both reagents) in a cylindrical Pyrex tube. The clear, colourless solution was nitrogen streamed for 1 hr, tube was quickly stoppered and irradiated at 350 nm for 110 hrs. A white precipitate had formed at the end of the irradiation period, the solution being again bright yellow. The crystalline material was recovered by filtration, m.pt. 230^o-231^o. I.r. spectroscopy (KBr disc) showed $\bar{\nu}_{\max}$: 3540, 3080, 3060, 3020, 2920, 1600, 1580, 1480, 1445, 1340, 1160, 1075 (doublet), 1050, 1030, 740, 700, 650 (doublet), 620 (triplet), 580, 560 cm⁻¹ and was clearly distinct from the i.r. spectrum of benzopinacol (KBr disc) $\bar{\nu}_{\max}$: 3568-3540 (characteristic doublet in the O-H stretching region), 3080, 3060, 3020, 1600, 1580, 1495, 1445, 1340, 1320, 1160, 1030, 760, 740, 700, 650 (doublet), 610 cm⁻¹. Analysis of the crystalline material

by t.l.c. on silica (benzene, chloroform) revealed the presence of one reaction product only, together with two very faint spots corresponding with starting materials. Recrystallization of the product from chloroform did not cause a significant alteration in the melting point (231° - 232°), or the solid state i.r. spectrum (KBr disc). The highest peak in the mass spectrum occurred at $m/e = 332$ (parent ion $(350)-18$, most probably loss of water), with major peaks at 343, 342, 339, 183, 182, 177, 152, 105, 77. The material was recrystallized once more from benzene and dried under vacuum for 24 hrs (m.pt. 232°). Treatment of the material according to Banchetti's procedure¹⁴⁷ resulted in partial (20%) loss of material but no significant increase in the melting point was observed (m.pt. 232° - 233°). Elemental analysis gave: C, 88.86; H, 6.60; calculated for $C_{26}H_{22}O$, C, 88.70; H, 6.75. The 1H F.T. n.m.r. spectrum of the material in $CDCl_3/CD_3COCD_3$ (ext. TMS ref.) showed a singlet at δ 7.13 (aromatic H) and four singlets at δ 5.23(A), δ 4.73(B), δ 3.02(C) and δ 2.81(D); peaks (C) and (D) disappeared on addition of D_2O ; the integrated intensities were in the ratio (A) + (B):(C) + (D) = 1:1. On the basis of the above evidence peaks (A) and (B) were assigned to the tertiary hydrogen in 1,1,2,2-tetraphenylethanol and peaks (C) and (D) to the hydroxyl hydrogen.

In a later experiment, diphenylmethane (2.10g, 0.0125 mole) and benzophenone (2.275g, 0.0125 mole) were dissolved in benzene (50 mls, 0.5M with respect to both reagents). The clear solution was nitrogen streamed for 1 hr, the Pyrex tube was quickly stoppered and the solution irradiated at 350 nm for 309.2 hrs. The solution became bright yellow and a white precipitate was formed at the bottom of the tube. The precipitate was separated by filtration, washed with a little cold benzene and dried under vacuum. Both the white precipitate and the yellow solution were examined by t.l.c. on silica (benzene, chloroform, ethanol). In both solvent and precipitate

1,1,2,2-tetraphenylethanol was identified. Starting material were not present, indicating that reaction had gone to completion. Analysis of the solvent, however, revealed the presence of spots corresponding to 1,1,2,2-tetraphenylethane and biphenyl ($C_6H_5-C_6H_5$). A very faint spot corresponding to benzopinacol was also observed. Analysis of the quantitatively recovered precipitate, m.pt. 216° - 218° showed the presence of some benzopinacol (faint spot). Recrystallization of the product from chloroform yielded pure 1,1,2,2-tetraphenylethanol, m.pt. 230° - 231° . Isolation of pure benzopinacol from the recrystallization liquors was not possible, probably due to small amounts of material present. Over 95% of pure tetraphenylethanol was obtained from the recrystallization.

2.3.a.iii. Comments on literature claims in the light of present results

Results from present experiments lead to the following conclusions:

a) the diphenylmethane-benzophenone photoreaction at 350 nm is a slow one, both in benzene solvent and without the use of solvent.

β) Irradiation of a neat benzophenone-diphenylmethane mixture is difficult to study because of the hard crystals which keep forming on the inside walls of the cylindrical Pyrex irradiation tube. These crystals considerably diminish the amount of light reaching the interior of the tube, it follows that irradiation times reported should be treated with caution. Also especially in the study of the 1:1 molar mixture, frequent opening of the tube, could have resulted in the upsetting of the precise 1:1 molar ratio.

γ) Irradiation of neat reagents for up to ca. 150 hrs (just over 6 days) under the above mentioned conditions resulted in only partial reaction, with 1,1,2,2-tetraphenylethanol as the only detectable product. Neither benzopinacol nor 1,1,2,2-tetraphenylethane were detected by t.l.c. on silica.

δ) During all irradiations a bright yellow colour has been observed. On the basis of earlier rationalizations (see 2.1.b, also 2.2.k) one could

attribute the yellow colour to the formation of structures such as those shown in Figure 2.50. Formation of a similar structure from the combination

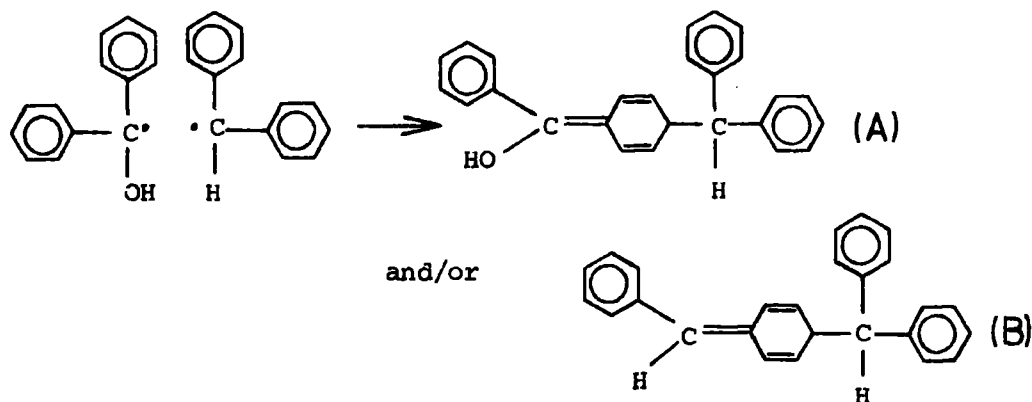


Figure 2.50

of two benzophenone ketyl radicals can be excluded since in the photoreduction of benzophenone in benzhydrol where two such primary radicals are initially formed, no yellow colour is observed (see 2.1.b.iii). Again, as in the case of the benzophenone-benzylalcohol photoreaction examined in 2.2.d such coloured species could act as internal light filters and could account for the low reaction rate.

e) Irradiation of a dilute benzene solution (0.01M total concentration) of benzophenone-diphenylmethane for 110 hrs resulted in incomplete reaction, yielding 1,1,2,2-tetraphenylethanol as the only detectable product. On the other hand, the reaction went to completion after 309.2 hrs of irradiation of a more concentrated solution (0.5M); the latter experiment however afforded benzopinacol, 1,1,2,2-tetraphenylethane and biphenyl, all in minute amounts.

These results suggest that the formation of benzopinacol and tetraphenylethane occurs only under fairly restricted conditions; thus neither are found in any of the irradiations of mixtures of benzophenone and diphenylmethane either neat or in dilute solution (0.01M) whereas at higher concentration (0.5M) these out-of-cage products were formed in detectable quantities.

Clearly the factors which control whether the in-cage product (1,1,2,2-tetraphenylethanol) or the out-of-cage products are formed must be fairly subtle. A detailed investigation of the effects of concentration and duration of irradiation have not been undertaken since it is established that under a wide range of conditions the required product, tetraphenylethanol is formed in > 95% yield; this would allow polymers of d.p. > 20 to be obtained from irradiation of suitable bifunctional analogues. Nevertheless it is possible to speculate about the explanation of these observations.

In the first instance it may be that the relative proportions of in-cage and out-of-cage reaction are controlled by the details of the medium's composition. Alternatively it may be that the out-of-cage products arise from a reaction of an intermediate (such as A, Figure 2.50) with ground state benzophenone, that is by a process somewhat analogous to that suggested previously by Filipescu,⁸¹ and shown in Figure 2.51.

Such a reaction could only occur when the concentration of (A) becomes high enough and therefore the probability of it coming in contact with a

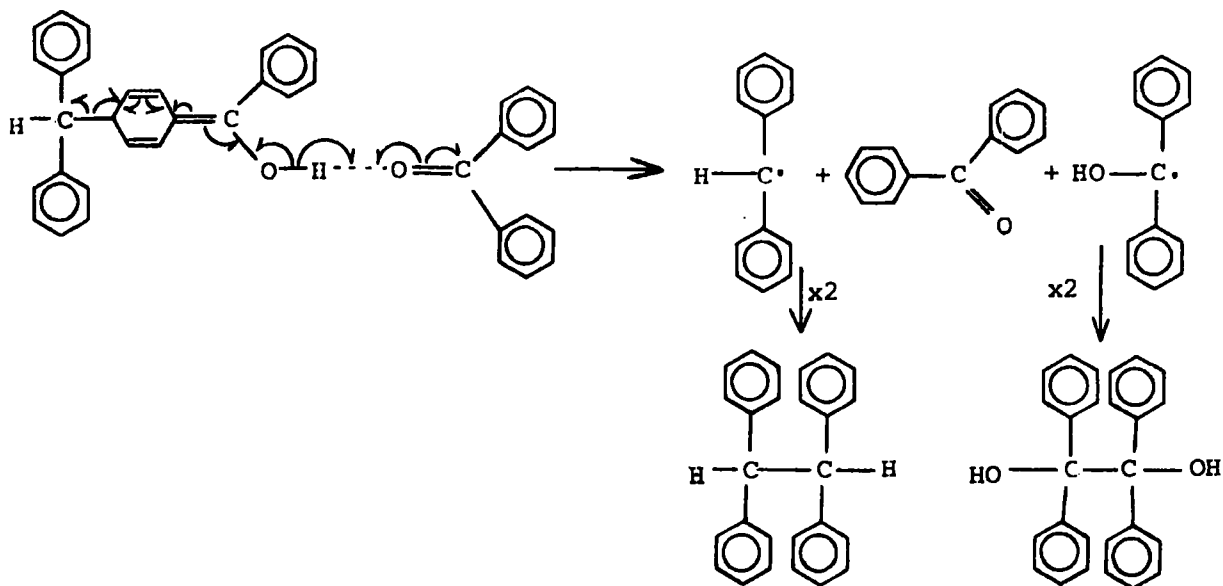


Figure 2.51

benzophenone molecule becomes significant. Increasing the concentration of the solution would also make the reaction more probable by increasing the chance of intermediate (A) coming in contact with a ground state benzophenone molecule. Irradiation of the neat benzophenone/diphenylmethane system may not lead to the formation of intermediate A in sufficiently high concentration because of the filter effect of the precipitating tetraphenylethanol. Thus the coloured structure (A) postulated in Figure 2.50 could be important in the rationalization of the observed slow reaction rate, the appearance of the yellow colour and the minute amounts of benzopinacol and 1,1,2,2-tetraphenylethane obtained under some conditions. It could not however explain the formation of biphenyl, which is most probably due to the prolonged irradiation of benzophenone in benzene solution.^{77,84-88} Such a reaction is known to yield benzopinacol and biphenyl as the main products,^{83,88} and by itself would account for the formation of both products mentioned above, would not however explain the formation of 1,1,2,2-tetraphenylethane.

The almost exclusive formation of 1,1,2,2-tetraphenylethanol in these reactions is a marked exception to the normal behaviour of triplet benzophenone in the presence of hydrogen donors, where benzopinacol formation is the main process. Even with aromatic hydrocarbon hydrogen donors which are structurally fairly closely related to diphenylmethane the in-cage dimerization of the primary radicals formed from initial hydrogen abstraction appears to be a relatively low yield process. As already mentioned toluene and cumene yield only ca. 50% of the corresponding cage products when irradiated in the presence of benzophenone.^{76,89}

On the other hand, the cage reaction product of the benzophenone-diphenylmethane reaction is a peculiar compound in itself, being insoluble or only slightly soluble in a very wide range of laboratory solvents in the cold, this being a property not shared by closely related structures such as benzopinacol, 1,2,2,2-tetraphenylethanol, triphenylglycol etc. The ¹H F.T.

n.m.r. spectrum of the material displays two distinct tertiary hydrogens and two hydroxyl hydrogen resonances. This could be attributed to the existence of two stable conformational isomers of the material, as shown in Figure 2.52, although it is worth noting that the related structures listed above do not show this effect. Due to the low solubility of the material in most cold

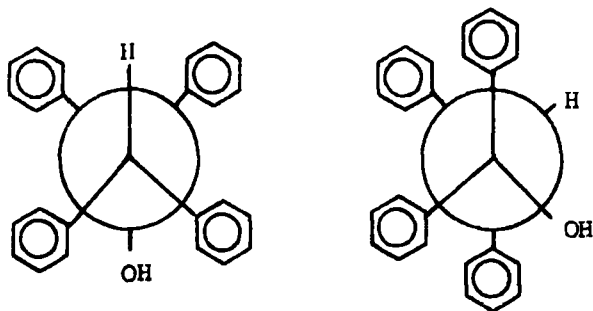


Figure 2.52

solvents it was not possible to investigate its solution phase i.r. spectrum or examine its photoreactivity with benzophenone in benzene solution at concentrations comparable to those of previous experiments.

Deciding whether the experimental results obtained in our hands are in agreement with earlier reports is a rather difficult task. Earlier papers^{119,142,146, 147} recorded limited experimental details; the irradiation source was the sun rather than a lamp of defined output, the temperature was not recorded and may well have been significant (ground temperatures in the North African desert may reach 70°C) and almost all these early papers are devoid of quantitative information. Spectral and chromatographic evidence not being available to these early workers, the melting point of the product acquired a central role in the determination of purity. Ways of drying of 1,1,2,2-tetraphenylethanol however were rarely specified and occlusion of traces of solvent can be critical in melting point determinations. Once these points are taken into account, an idea of the difficulties arising



in assessing previous results becomes clear.

Wegler's claim¹⁴² that as much as 20% benzopinacol and hydrocarbon can be present as the by-products of the insolation experiment seems to be grossly exaggerated. Wegler must have expected to observe the formation of benzopinacol in view of the reported behaviour of benzophenone on insolation in the presence of various hydrogen donors; it is however surprising that Paternò categorically excluded the formation of benzopinacol or any other by-products in this case¹¹⁹ since he had reported so many examples of benzopinacol formation. A possible explanation could be that any benzopinacol or tetraphenylethane formed in Paternò's experiments was destroyed by boiling the reaction product in benzene before examination. In our hands, boiling a toluene solution containing an 1:1 molar mixture of benzopinacol and 1,1,2,2-tetraphenylethane for 3 hrs resulted in the total disappearance of starting materials and formation of 1,1,2,2-tetraphenylethanol with traces of benzophenone and benzhydrol as by-products.

Banchetti¹⁴⁷ claimed to have isolated benzopinacol out of his own insolation experiment, by considerably reducing the volume of the mother liquors of recrystallization of the crude 1,1,2,2-tetraphenylethanol. He did not however specify the percentage of benzopinacol isolated.¹⁴⁷ On the other hand, the evidence for the pinacol formation (behaviour under the microscope) is open to question.

Banchetti's purification technique¹⁴⁷ should also be considered with great caution since 1,1,2,2-tetraphenylethanol itself is not very stable at high temperatures, decomposing by cleavage of the ethane C-C bond.¹⁵⁰ The reported by-products, benzopinacol and 1,1,2,2-tetraphenylethane are very soluble in solvents like acetone and chloroform even at room temperature; it should therefore be adequate to wash and then recrystallize the product from one of these solvents. In our hands, purification of an 1,1,2,2-tetraphenylethanol sample (already recrystallized from chloroform and benzene) using Banchetti's method (boiling with cyclohexanol) did not significantly

affect the m.pt. or the i.r. spectrum of the material recovered. It was however interesting to notice traces of $(C_6H_5)_2CO$ and $(C_6H_5)_2CH_2$ present in cyclohexanol (t.l.c. on silica, benzene) probably resulted from partial thermal decomposition of the tetraphenylethanol at relatively high temperatures. In one of our initial irradiations of neat benzophenone and diphenylmethane, crude product obtained was recrystallized from benzene and chloroform only; t.l.c. on silica, ^{13}C F.T. n.m.r. and 1H F.T. n.m.r. evidence however showed the product to be pure. No benzopinacol or 1,1,2,2-tetraphenylethane were detected which directly contradicts Banchetti's assertions. The long arguments concerning melting points demonstrate the shortcomings of this particular criterion of purity; it is worth noting that 1,1,2,2-tetraphenylethanol prepared via ground state chemistry has also given varying melting points, 235° ,¹⁴¹ $232^\circ-233^\circ$,¹⁴⁶ $243^\circ-244^\circ$,¹⁴⁹ 236.5° ,¹⁴³ $232^\circ-233^\circ$,¹⁴⁴ $231^\circ-232.5^\circ$,¹⁴⁸ $232.5^\circ-233^\circ$.¹⁴⁵ It seems quite likely that the compound exists in two isomeric forms, possibly cisoid and transoid conformational isomers, having different m.pt.s.; 1H F.T. n.m.r. evidence supports this proposition. The varying m.pt.s. recorded could thus result from varying proportions of the two isomeric forms.

On the basis of the results obtained from the model reaction, one would expect the irradiation of an aromatic diketone in the presence of an equimolar amount of a bisbenzylbenzene to yield a linear polymer containing at least 95% tetraphenylethanol units in the backbone. By analogy with the model reaction the polymer formation would be expected to be slow and the product would be expected to contain a small percentage of benzopinacol and tetraphenylethane units. The formation of these two types of unit would be chain propagating rather than chain terminating and indeed no reactions which would be chain terminating were observed in this study of the model reaction, apart from the formation of traces of biphenyl which presumably arose from

reaction of benzophenone with the solvent. Finally, crosslinking and/or branching might occur via the tertiary hydrogen in the tetraphenylethanol and tetraphenylethane types of unit of the proposed polymer.

For the actual polymer forming reaction, m-dibenzylbenzene and m- and p-dibenzylbenzenes were selected as appropriate monomers. Benzene was chosen as the solvent.

2.3.b. Synthesis of monomers

2.3.b.1. Discussion of possible routes

The preparation, purification and characterization of m-dibenzylbenzene has already been described in section 2.2.j.iii.

The preparation of arylalkylated aromatic hydrocarbons has been the subject of many reports. Zincke obtained 1,4-, 1,2-dibenzylbenzene and diphenylmethane by the action of metallic zinc on a mixture of benzylchloride and benzene.¹⁵¹ Similar results were obtained by Thiele and Balhom, who reacted benzene with formaldehyde in the presence of sulphuric acid.¹⁵² Huston and Friedmann showed that the aluminium chloride catalysed reaction of benzylchloride with benzene gave a complex mixture from which they isolated diphenylmethane, anthracene, anthraquinone, a little 1,2-dibenzylbenzene and 1,4-dibenzylbenzene, m.pt. 85°-86° (alcohol).

Japanese workers reported the synthesis of p-phenylenedibenzyl in a very impure state (melting point range: 20°) by stirring a mixture of benzene and benzylchloride in tetrachloroethane with zinc powder under nitrogen; the impure material was found to be photoconductive.¹⁵⁴ Profft, Drechsler and Oberender,¹⁵⁵ obtained low yields of 1,4-dibenzylbenzene (m.pt. 86.5°) from the reaction of tetrachlorodurene with benzene under Friedel-Crafts conditions.

Pure 1,4-dibenzylbenzene, m.pt. 84° - 85° (acetone) was prepared by the one-step hydrolysis and decarboxylation of $C_6H_5-CH_2-p-(C_6H_4-CH(CCl_3)C_6H_5)$; ¹⁵⁶ the same compound was also obtained from the action of N_2H_4/KOH at over 190° on 1,4-(p-bromobenzoyl)benzene. ¹⁵⁶

Possible routes for alkane preparation from the corresponding carbonyl compound include the Clemensen reduction and the Wolff-Kishner reduction. ¹⁵⁷

The Clemensen reduction involves treating the carbonyl compound with amalgamated zinc and concentrated HCl, yielding hydrocarbon as the main product, but also variable quantities of the secondary alcohols (in the case of ketones) and unsaturated substances. Purely aromatic ketones however do not give satisfactory results; pinacols and resinous products often predominate. ¹⁵⁷ The Wolff-Kishner reduction affords hydrocarbons upon heating the corresponding hydrazone or semicarbazone of the carbonyl compound with potassium hydroxide or with sodium ethoxide in a sealed tube. ^{157,158} The Huang-Minlon modification of the reaction (formation and decomposition of the hydrazone in one reaction vessel) is experimentally more convenient and reported to proceed in better yield.

Finally arylalkanes may also be synthesized by reduction of the corresponding arylalkylhalides or arylalkyltosylesters. ¹⁵⁸ This synthetic route would involve reduction of the corresponding carbonyl compound to the alcohol, ¹⁵⁷ conversion of the alcohol to the arylalkylhalide or to the tosyl ester, and finally reduction with an efficient reducing agent, such as $LiAlH_4$. ¹⁵⁸

2.3.b.ii. Selection of routes

In our hands, attempts to prepare m-dibenzylbenzene by reducing the corresponding dicarbonyl compound, m-dibenzoylbenzene via either the Wolff-Kishner reduction (Huang-Minlon modification), or the Clemensen reduction gave unsatisfactory results. A mixture of products was obtained in the latter

case which was found difficult to separate, whereas the former route resulted in the formation of dark intractable tars.

Repetition of the Japanese workers' experiment¹⁵⁴ yielded a small quantity of a mixture comprising at least 10 components (t.l.c. on silica, benzene).

The failure to obtain the arylalkylated hydrocarbons by the above described routes led to the investigation of alternative syntheses of 1,4- and 1,3-dibenzylbenzene, shown schematically in Figure 2.53. In addition to these routes one could also attempt the preparation of the dibromide derivative of the bisbenzhydrol by treating it with constant boiling HBr followed by reduction using an efficient H^- source in an appropriate solvent.

Another attractive idea would be to utilise a reaction reported by Grinter and Mason; they obtained triphenylmethane by refluxing triphenylcarbinol in formic acid.¹⁵⁹ If this process could be extended to the conversion of benzhydrol to diphenylmethane, an easy synthesis of the required monomers might be available from bisbenzhydrols (Figure 2.54).

The experimental details of these various attempts to synthesize the required monomers are given below. The steps referred to are those indicated in Figure 2.53.

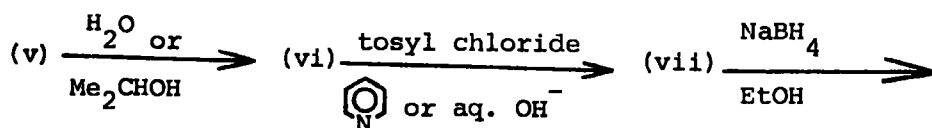
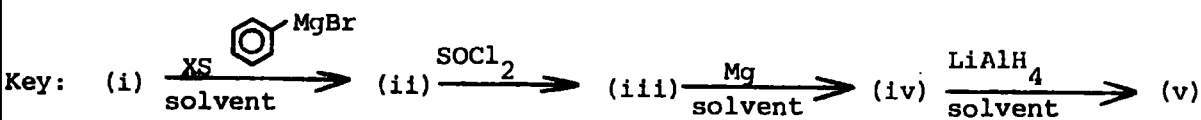
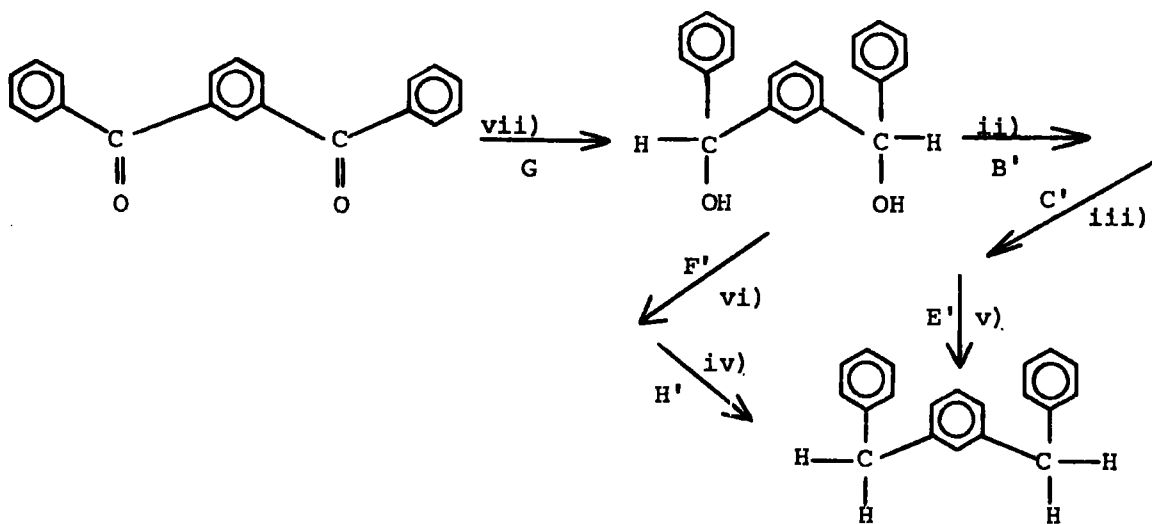
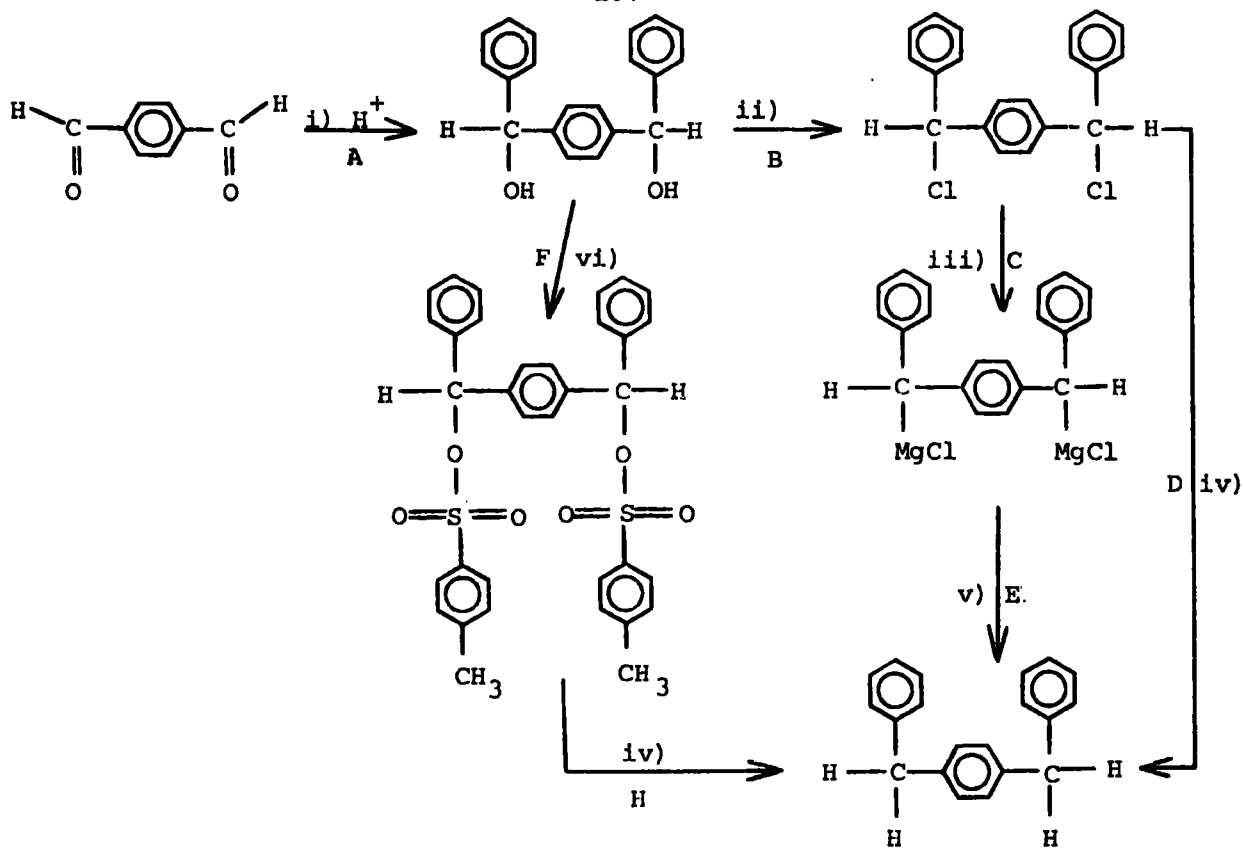


Figure 2.53

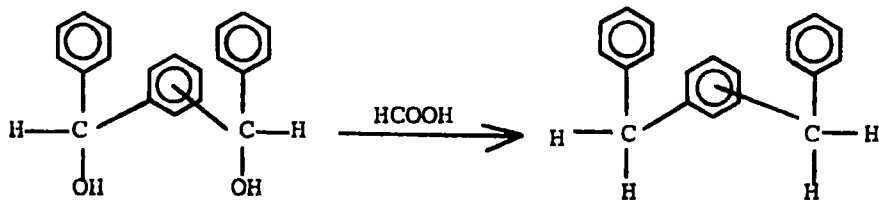


Figure 2.54

Experimental

Step A: Magnesium turnings (48.60g) in a 3 necked round bottom flask fitted with a mechanical stirrer, pressure equalizing dropping funnel, double surface reflux condenser, nitrogen gas inlet and thermometer well were covered with 1.8 litres freshly distilled THF. The dropping funnel was filled with dry bromobenzene (314.00g) and a few drops were added with efficient stirring. The reaction started smoothly after about 5 mins, without the use of catalyst. Addition of bromobenzene was regulated by monitoring the pot temperature which was maintained between 70°-80°. The solution got progressively darker and was dark brown after about 2½ hrs when most of the magnesium had been consumed. After addition of bromobenzene had finished, pot contents were stirred for a further 1 hr period, at the end of which temperature dropped to 30°. Slow addition of terephthalaldehyde (67.0g) on 0.7 litre THF was then started with efficient stirring, taking care to maintain the pot temperature below 40°. After all the terephthalaldehyde solution had been added, the pot contents were dark red. The mixture was boiled under reflux for 2 hrs, cooled to room temperature, and carefully poured into ice/water (2.5 litres) acidified with HCl and stirred for 1 hr. The organic layer was separated and the water layer was extracted twice with benzene (2 x 300 mls). The combined THF/benzene solutions were dried over anhydrous magnesium sulphate and finally volatile solvents were removed under vacuum to give 116g of crude product (80%). Recrystallizations from ethanol/water (75:25) afforded 70% of pure product (t.l.c. on silica, benzene, chloroform), m.pt. 169°-170° (lit. ¹⁶⁰ 171°) displaying the following infrared absorptions (KBr disc, $\bar{\nu}_{\text{max}}$;) 3270, 3080, 3040, 3020, 2900, 1600, 1510, 1490, 1450, 1420, 1340, 1280, 1240 (doublet), 1200, 1185, 1155, 1120, 1080, 1030, 1020, 1010, 920, 870, 830, 790, 740, 700, 635, 570, 495 cm^{-1} .

The reaction did not proceed in ether solvent due to the low solubility of terephthalaldehyde in that medium.

Step B: p-Bisbenzhydrol (40g) obtained from step A and freshly distilled thionylchloride (180 mls) were heated under reflux for 2 hrs. The excess of thionylchloride was distilled off under reduced pressure and 100 mls of acetic acid plus 2 drops of concentrated hydrochloric acid were added. The white solid which precipitated was filtered off and treated again with 60 mls of glacial acetic acid plus two drops of concentrated hydrochloric acid. The solution was boiled with decolourizing charcoal, filtered hot and the colourless filtrate allowed to cool. Cooling caused the precipitation of the colourless dichloride which was filtered and dried by pumping under vacuum for 48 hrs at 60°. White needles were obtained from chloroform/hexane, m.pt. 190° (lit.¹⁶¹ 197°-198°), $\bar{\nu}_{\max}$ (KBr disc): 3080, 3060, 3035, 2960, 1600, 1585, 1510, 1500, 1450, 1425, 1345, 1260, 1225, 1120, 1080, 1030, 1020, 1000, 835, 785, 735, 700, 635, 615, 495 cm⁻¹.

Steps C,E: p-Bisbenzhydrylchloride (10.0g) obtained from step B were slowly added under nitrogen to 200 mls freshly distilled THF and magnesium turnings (5.0g) with efficient stirring. Reaction was allowed to proceed for 1 hr and then half of the resulting solution was stirred with 100 mls isopropanol for 8 hrs, whereas the other half was poured into 500 mls of ice/water mixture and stirred for 5 hrs. Both reactions gave largely p-bisbenzhydrol, unreacted p-bisbenzhydrylchloride and a few other minor products but no p-bisbenzylbenzene was isolated.

Step F: p-Bisbenzhydrol (10.0g) obtained from step A was dissolved in freshly distilled pyridine (300 mls) and toluene p-sulphonylchloride (10.0g) was slowly added. After 3 hrs of stirring under nitrogen, solution was heated to 60° for 1 hr and then cooled to room temperature. Addition of 0.5 litres of water caused the precipitation of a yellow oil which was

separated and pumped under vacuum for 48 hrs. Resulted resinous material was found to be a mixture of at least 8 components by t.l.c. on silica (benzene). Most of it dissolved in hot water and stayed in solution even on cooling to 5°.

Preparation of p-bisbenzhydrylbromide: p-Bisbenzhydrol (20g) obtained from step A was slowly added to constant boiling HBr (400 mls) and the resultant brown solution was boiled under reflux for 3 hrs. Most of the water was taken off by distillation under reduced pressure, the residue was dissolved in 500 mls of benzene and boiled using a Dean-Stark apparatus. When nearly all the water had come off, benzene solution was dried over anhydrous magnesium sulphate and then volume of benzene was reduced to 100 mls. Addition of 600 mls of hexane caused the precipitation of a material which was filtered and dried by pumping under reduced pressure for 24 hrs. The solid (85%) thus obtained, m.pt. 105°-108° (lit.¹⁶⁰ 112.5°), was found to contain bromine by Lassaigne's test; $\bar{\nu}_{\text{max}}$ (nujol mull): 3080, 3040, 3020, 1510, 1490, 1420, 1300, 1250, 1200, 1165, 1120, 1075, 1030, 1020, 1000, 830, 775 (doublet), 730, 700, 675, 605, 495 (doublet) cm^{-1} . Examination of the material by t.l.c. on silica (benzene) revealed the presence of one component only.

Attempted reduction of the p-bisbenzhydrylbromide: The bromide obtained from the previous preparation (15.0g) was dissolved in dry benzene (200 mls); $\text{NaAlH}_2(\text{OCH}_2\text{CH}_2\text{OCH}_3)_2$ (Vitride) in benzene (10% excess) was added and the mixture was refluxed for 2 hrs. After cooling and destruction of the excess Vitride with water, the benzene layer was separated, dried over anhydrous magnesium sulphate and the solvent was removed under reduced pressure to yield a whitish powder (13.0g), m.pt. 185°-194° which was found to be insoluble in hot ethanol or cold hexane. It was dissolved in toluene and precipitated by slow addition of 60°-80° petroleum ether. The product

thus obtained was dried by pumping under vacuum for 24 hrs at 40° and examined by i.r. spectroscopy (Nujol mull, $\bar{\nu}_{\max}$: 3080, 3060, 3025, 1600, 1580, 1510, 1490, 1450, 1420, 1375, 1160, 1110, 1075, 1030, 1020, 790, 730, 700, 625 cm^{-1}). It was not possible to obtain the product in a crystalline form; it appeared to be a relatively high molecular weight material.

Attempted reduction of the p-bisbenzhydrol in formic acid: p-Bisbenzhydrol (35.0g) obtained from step A was added to a large volume (2 litres) of 98% formic acid at 60°. After each addition vigorous effervescence was observed and the evolved gases gave a white precipitate with lime water. After the addition was complete, the resultant brown solution was heated at 60° for 6 hrs with stirring and product was precipitated after cooling by pouring the solution into 5 litres of water. A yellow oil (22.0g) was obtained which was separated, dried by pumping under reduced pressure at 60° for 24 hrs and examined by i.r. spectroscopy (contact film, $\bar{\nu}_{\max}$: 3060, 3040, 2920, 1740, 1510, 1490, 1450, 1370, 1160, 1080, 1030 (doublet), 945, 920, 850, 815, 760, 730, 700, 630 cm^{-1}). This yellow oil was distilled under vacuum (15-20 mmHg, 90°-260°) to yield a yellowish oil which crystallized slowly on standing in a sample bottle. The i.r. spectrum was essentially the same as the one of the yellow oil before distillation. The high boiling fraction which remained in the distillation pot was extracted with chloroform and precipitated with 60°-80° petroleum ether to yield a whitish powder. Neither the yellow nor the white material appeared to be the desired product.

Step G: To m-dibenzoylbenzene (100g) (obtained as described in 2.2.j.iii) in 2000 mls ethanol in a 5 litre round bottom flask fitted with reflux condenser was slowly added a solution of NaBH_4 (45g) in water (300 mls). The resultant solution was refluxed for 5 hrs and cooled to room temperature. Following the destruction of unreacted borohydride with 5% acetic acid solution, the volume of solvent was reduced to 200 mls. Addition of a large

volume of water caused the precipitation of a white material which was collected on a filter, washed successively with water, 5% HCl solution and 5% aqueous sodium carbonate solution, and then boiled with activated animal charcoal in ethanol solution. The white solid obtained after recrystallizations from ethanol/water (70:30) (80%) was examined by i.r. spectroscopy (KBr disc, $\bar{\nu}_{\max}$: 3300, 3060, 3020, 2880, 1600, 1490, 1475, 1450, 1335, 1270, 1235, 1195, 1070, 1030, 1020, 950, 920 (doublet), 830, 800, 780, 760, 740, 700 (doublet), 600, 545 cm^{-1} , m.pt. 151^o-153^o.

Step B': was carried out in exactly the same way as step B. A dark oil was obtained in 90% yield which was examined by Lassaigne's method and was found to contain chlorine. This product was not purified but was used as obtained for step D'. The infrared spectrum of the oil was recorded (contact film, $\bar{\nu}_{\max}$: 3080, 3060, 3020, 2940, 1600, 1590, 1490, 1450, 1210, 1150, 1075, 1030, 1000, 830, 790, 760, 730, 700, 625, 580 cm^{-1}).

Step D: LiAlH_4 (10g, 0.26 mole) in a 2 litre 3 necked round bottom flask fitted with a mechanical stirrer, pressure equalizing dropping funnel, nitrogen gas inlet and double surface reflux condenser leading to a concentrated sulphuric acid bubbler was covered with 1 litre sodium dried ether; the mixture was stirred vigorously for 30 mins and then cooled to 0^o by means of an ice/water/salt bath. p-Bisbenzhydrylchloride (32.7g, 0.1 mole) obtained from step B was shaken with ether (0.5 litres) and the resulted slurry was slowly added to the mixture in the flask with vigorous stirring. The colour of the mixture changed eventually from grey to light green. After addition was complete, the mixture was gently refluxed for 12 hrs. The excess lithium aluminium hydride was destroyed by successive slow additions of water (10g), 10% NaOH (15g) and water (30g),¹⁶² resulting in the formation of a granular precipitate which was filtered off, washed with two 200 mls portions of benzene and destroyed by slowly adding it into a large volume of

6N HCl until a clear solution was formed. The combined ethereal and benzene solutions were dried over anhydrous magnesium sulphate and finally the solvents were removed under reduced pressure. A whitish solid was obtained which was recrystallized several times from hot ethanol, boiled with activated animal charcoal and then recrystallized several times from methanol and ethanol to give a yellowish crystalline material impure 1,4-bisbenzylbenzene (30%), melting at 83° - 85° (lit.¹⁴⁰ 86°).

Step D': was carried out in the same way as step D apart from the addition of the m-bisbenzhydrylchloride which was easier than in D, since the compound is soluble in ether. Reaction afforded a brown oil which was distilled from a short column, boiled with activated animal charcoal in benzene and distilled again to yield a yellow oil; absence of chlorine from the oil was established by Lassaigne's test. Finally a yellowish oil was obtained by distillation at 220° - $239^{\circ}/14$ mmHg (lit.¹⁴⁰ 229° - $231^{\circ}/14$ mmHg, 226° - $227^{\circ}/19$ mmHg).

2.3.b.iii. Reasons for failure

The results obtained in 2.3.b.ii indicate that the only successful step out of those shown in Figure 2.53 are A, G, B, and B', D and D'.

Treatment of 1,4-bisbenzhydryl with constant boiling HBr did in fact give a bromide, but reduction of the bromide with Vitride ($\text{NaAlH}_2(\text{OCH}_2\text{CH}_2\text{OCH}_2)_2$) in benzene solution at 80° resulted in the formation of polymeric materials. On the other hand reduction of the corresponding dichloride with lithium aluminium hydride in ether at 0° - 37° resulted in the formation of dibenzylbenzene. Both Vitride and lithium aluminium hydride are excellent sources of hydride anion. The two starting materials though bear different halide substituents, bromine being bulkier and not as strongly attached to the carbon atom as chlorine. One could therefore rationalize the difference in behaviour between the two benzylhalides by postulating partial ionization of

the p-bisbenzhydrylbromide yielding a stable carbenium ion which could then initiate polymerization by electrophilic attack on phenyl rings. Alternatively the polymerization may have occurred during the formation of the bromide; again a carbenium intermediate is involved and this might have attacked an aromatic ring or been quenched by a hydroxyl group.

The treatment of p-bisbenzhydryl with a large excess of formic acid would appear to have yielded the formate ester and polymeric materials, possibly via the route shown in Figure 2.55. The reasons why triphenylcarbinol is converted to triphenylmethane, whereas benzhydryl hydroxyl is not replaced

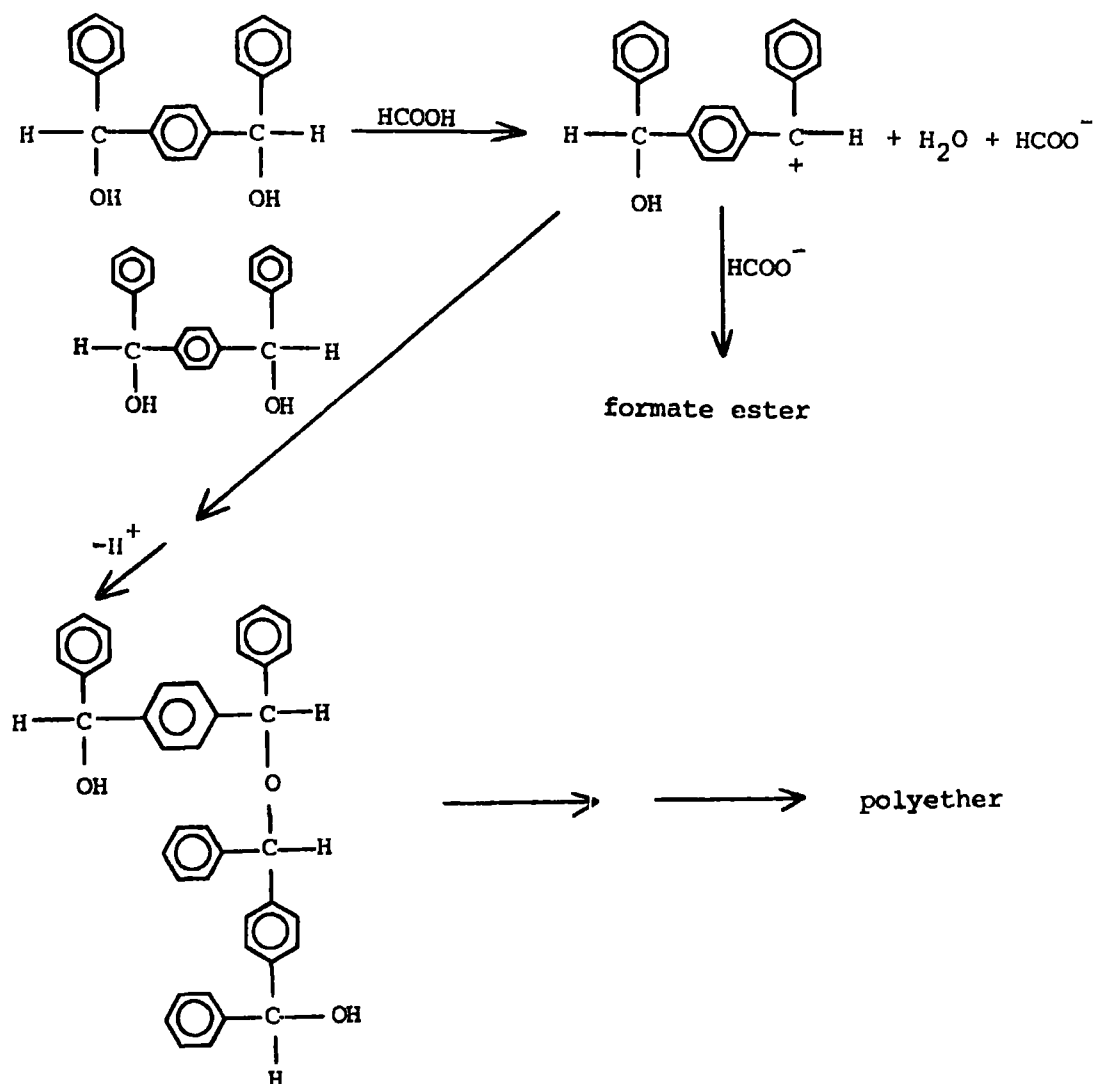


Figure 2.55

by hydrogen under the same conditions probably lie in a combination of steric and electronic effects.

2.3.b.vi. Purification and proof of structure

1,4-dibenzylbenzene was purified by two more recrystallizations from absolute ethanol, boiling with activated animal charcoal in benzene, sublimation at $106^{\circ}/0.01$ mmHg, another recrystallization from ethanol and washing with the same solvent (10°). It was then pumped under reduced pressure (0.01 mmHg) at 40° for 48 hrs. This procedure gave 20% of pure product, m.pt. 85.8° (lit. 140 86°) in big plates analyzing as follows: C 92.56, H 7.12; calculated for $C_{20}H_{18}$ C 92.98, H 7.02. The substance was found to give a single spot on t.l.c. on silica (benzene, chloroform); $\bar{\nu}_{\max}$ (KBr disc): 3070, 3060, 3020, 2900 (doublet), 2430, 1950, 1915, 1600, 1595, 1510, 1490, 1450, 1430, 1415, 1335, 1320, 1210, 1175, 1160, 1105, 1070, 1030, 930, 855, 760, 725, 700, 600, 485, 460 cm^{-1} . The mass spectrum extended to $m/e = 258$ corresponding to the parent ion; main peaks at 192, 167, 150, 121, 120, 90, 77. Lassaigne's test on the sample showed the absence of chlorine, as did the mass spectrum. The ^1H n.m.r. spectrum in CDCl_3 (int. TMS ref.) showed two peaks in the aromatic hydrogen region (δ 7.10, δ 6.96) and a singlet at δ 3.80.

1,3-Dibenzylbenzene was purified by further distillations between 220° - $235^{\circ}/15$ mmHg and finally by a distillation at $140^{\circ}/3$ mmHg under nitrogen. A colourless oil was obtained, analyzing as follows: C 92.73, H 7.23 (calculated for $C_{20}H_{18}$ C 92.88, H 7.02); t.l.c. on silica (benzene, chloroform) gave a single spot; $\bar{\nu}_{\max}$ (contact film): 3100, 3080, 3040, 3020, 2900, 2840, 1940, 1870, 1800, 1600, 1490 (doublet), 1445 (doublet), 1090, 1075, 1030, 1000, 770, 750, 730, 700, 600, 550, $460, 430\text{ cm}^{-1}$. Lassaigne's test on the product showed the absence of chlorine. The mass spectrum extended to $m/e = 258$, corresponding to the parent ion; main

peaks at 181, 180, 168, 166, 153, 91, 77.

2.3.c. Polymerization runs

2.3.c.1. A preliminary investigation

1,4-Dibenzylbenzene (1.2918g, 0.005 mole) and 1,3-dibenzoylbenzene (1.4316g, 0.005 mole) were dissolved in benzene (50 mls, 0.2M with respect to both reagents) in a cylindrical Pyrex vessel. The clear, colourless solution was nitrogen streamed for 30 mins, the tube was quickly stoppered and irradiated at 350 nm for 24 hrs. A bright yellow colour developed at an early stage during the irradiation and a trace of a white precipitate appeared at the bottom of the tube. Benzene solvent was removed by freeze-drying and a yellow material was quantitatively recovered showing both hydroxyl and benzophenone-type carbonyl bands in the i.r. region. The presence of the strong carbonyl band was attributed to either unreacted monomer or to low molecular weight material formed (telomer of poly-(1,1,2,2-tetraphenylethanol)); thus the earlier expectation that the polymerization reaction might be a slow one was confirmed. On the other hand, the presence of the hydroxyl band indicated that, as expected, hydrogen abstraction was taking place and that the benzophenone-type ketyl radical of m-dibenzoylbenzene was in fact yielding products either by diffusion out of the cage and dimerization or by in-cage combination with the radical resulting from p-bisbenzylbenzene. The i.r. spectrum of the yellowish powder displayed the following absorptions (KBr disc, $\bar{\nu}_{\max}$): 3540, 3520 - ca. 3400 (broad), 3080, 3050, 3020 (strong), 2900, 1655, 1600, 1580, 1510, 1480, 1445, 1420, 1320, 1275, 1160, 1090, 1030, 1000, 845, 830, 780, 740 (doublet), 700, 640, 620, 555 cm^{-1} . Comparison with the i.r. spectrum of polybenzopinacol M (prepared by irradiation of m-dibenzoylbenzene in isopropanol/benzene, see Table 2.2), synthesized by Andrews and Feast⁶⁴ (KBr disc, $\bar{\nu}_{\max}$: 3560, 3500 - ca. 3400 (broad), 3060, 3020 (weak),

2960 (possibly occluded solvent or incorporated isopropanol moieties), 1600, 1560, 1495, 1450, 1420, 1330, 1265, 1155, 1100, 1030, 920, 790, 765, 750, 700, 645, 615 cm^{-1}) revealed that the two spectra differ in many regions; differences in the relative intensities of the O-H and aromatic C-H absorptions were evident, the yellow material having a much stronger C-H aromatic group of peaks. Differences in the fingerprint region of the spectrum were also observed. Washing the material obtained with cold hexane in order to eliminate any unreacted bisbenzylbenzene, followed by drying under vacuum, did not alter the colour, weight or the solid state i.r. spectrum.

2.3.c.ii. Examination of the effect of concentration

The irradiations shown in Table 2.7 were carried out in the same way as in the previous experiment (cylindrical Pyrex tubes, nitrogen streaming followed by stoppering, irradiation at 350 nm). In all cases, solution went bright yellow and a trace of a white precipitate was observed at the bottom of the tube; it was separated from the yellow solution by filtration, washed with a few drops of cold benzene, dried under vacuum and weighed; in all cases it amounted to ca. 5% of the total weight of the two reactants used, and was insoluble in a wide range of laboratory solvents.

Benzene solvent was removed from yellow solutions by freeze-drying and yellow solids were obtained which were dried by pumping under reduced pressure and examined by i.r. spectroscopy (KBr discs). The spectra obtained from experiments A, B and C were very similar and comparable to the i.r. spectrum of the yellow product obtained from the 24 hrs irradiation (2.3.c.i.), but the benzophenone-type carbonyl band was much weaker, indicating that longer irradiation times resulted in increased consumption of at least one of the monomers (*m*-dibenzoylbenzene). The relative intensities of the carbonyl band in the spectra of the three products was roughly the same, indicating that in the concentration range 0.1M-1M reaction rate (as monitored by

Table 2.7

Irradiations of equimolar solutions of m-dibenzoylbenzene/m- and p-dibenzylbenzene of varying concentrations

Expt.	Bisketone	Alkane	Solvent	Total concn.	Irradiation time
A	m-dibenzoylbenzene 0.7158g 0.0025 mole	p-bisbenzylbenzene 0.6459g 0.0025 mole	benzene 50 mls	0.1M	240 hrs
B	m-dibenzoylbenzene 0.7158g 0.0025 mole	p-bisbenzylbenzene 0.6459g 0.0025 mole	benzene 25 mls	0.2M	240 hrs
C	m-dibenzoylbenzene 0.7158g 0.0025 mole	p-bisbenzylbenzene 0.6459g 0.0025 mole	benzene 12.5 mls	0.4M	240 hrs
D	m-dibenzoylbenzene 2.860g 0.01 mole	m-bisbenzylbenzene 2.580g 0.01 mole	benzene 20 mls	1M	240 hrs

carbonyl consumption) was not dramatically changing.

A typical i.r. spectrum of the white insoluble precipitate obtained from experiments A, B and C displayed the following absorptions (KBr disc, $\bar{\nu}_{\max}$): 3550 (very strong), 3090, 3060, 3020, 2960, 1660, 1600, 1580, 1495, 1475, 1445, 1420, 1340-1270 (broad), 1260, 1175, 1160, 1100, 1035, 1020, 960, 925, 910, 845, 805, 775, 745, 710, 700, 680, 645, 635, 610, 570, 540, 470 cm^{-1} .

The i.r. spectrum of the white insoluble precipitate obtained from experiment D was not different from the one described in the preceding paragraph. The benzene-soluble material was dried by pumping under reduced pressure following removal of solvent; a portion of it was precipitated from benzene/60°-80° petroleum ether and a white powder was thus obtained analyzing

as follows: C 85.98, H 5.92. The i.r. spectrum of the white powder was recorded (KBr disc, $\bar{\nu}_{\max}$): 3550, 3520 - ca. 3400 (broad), 3080, 3040, 3020, 2920-2845 (possibly occluded petroleum ether), 1655 (strong), 1600, 1580, 1495, 1445, 1420, 1320, 1275, 1175, 1160, 1140, 1045, 1030, 1000, 920, 845, 815, 750, 700, 640, 620 cm^{-1} . The carbonyl peak appeared considerably stronger than in the i.r. spectra of the yellow products obtained from experiments A, B and C, indicating that consumption of carbonyl in the reaction between the two meta isomers was qualitatively slower than in the reaction between *m*-dibenzoylbenzene and *p*-dibenzoylbenzene.

Another portion (2.0g) of the crude yellow product isolated from experiment D was dissolved in benzene (10 mls), nitrogen streamed, and irradiated at 350 nm for 435 hrs. Again, a white solid precipitated during irradiation (ca. 6%), which displayed an i.r. spectrum similar to those already described for the white precipitates previously obtained. The yellow benzene solution was separated, and the solvent was removed by freeze-drying yielding a yellow solid which was precipitated from benzene/60°-80° petroleum ether. The white powder obtained from precipitation was examined by i.r. spectroscopy; a very small absorption at ca. 1660 cm^{-1} was observed indicating that most of the *m*-dibenzoylbenzene had been consumed. The solution phase i.r. spectrum of this product (CCl_4 solvent, saturated solution, 0.1 mm cell) showed a singlet at 3560 cm^{-1} (O-H), a doublet at 3060-3020 cm^{-1} (aromatic C-H), and a broad singlet at 2920 cm^{-1} (aliphatic C-H); the relative intensities of the O-H and aromatic C-H peaks were roughly the same (aromatic C-H slightly stronger). The solution phase i.r. spectrum of polybenzopinacol M⁶⁴ (see Table 2.2). examined under the same conditions showed a singlet at 3560 cm^{-1} and a shoulder at 3600 cm^{-1} (O-H), a very broad absorption between 3500-3400 cm^{-1} (hydrogen bonded O-H), two singlets at 3060-3030 cm^{-1} (aromatic C-H), and a strong singlet at 2960 cm^{-1} (aliphatic

C-H, possibly due to occluded solvent). The O-H peak was considerably stronger than the two aromatic C-H peaks.

The above preliminary investigations led to the conclusion that the product obtained from the m-dibenzoylbenzene/m-dibenzylbenzene reaction was not a polybenzopinacol (by comparative solid state and solution phase i.r. evidence). This was an encouraging result and gave the incentive for a more thorough examination of the polyaddition reaction.

2.3.c.iii. Large scale experiments

α) m-Dibenzoylbenzene/p-dibenzylbenzene

m-Dibenzoylbenzene (28.631g, 0.1 mole) and p-dibenzylbenzene (25.834g, 0.1 mole) were dissolved in sodium-dried benzene (500 mls, 0.4M with respect to both reagents). The solution was nitrogen streamed for 30 mins, the cylindrical Pyrex tube was quickly stoppered and irradiated at 350 nm for 263 hrs. During irradiation a white material precipitated, whereas remaining solution became bright yellow. The white material (A) was recovered by filtration, washed with a little cold benzene, dried by pumping under reduced pressure, weighed (2.482g) and examined by i.r. spectroscopy (KBr disc); spectrum obtained was essentially the same as the ones recorded for previously obtained white precipitates, already described in 2.3.c.iii. The yellow solution separated yielded, following removal of solvent by freeze-drying and pumping under reduced pressure, a yellow material (B) (51.980g) which was spectroscopically examined (i.r., KBr disc); it was then redissolved in benzene (500 mls) and re-irradiated for a further 144 hrs period, yielding another white precipitate (C) (0.832g) and a yellow solid (D) (51.140g).

Solid (D) was then divided into 2 x 25g portions. Two benzene solutions were made:

25g of solid (D) in 100 mls benzene

25g of solid (D) in 250 mls benzene

The two solutions were re-irradiated for 118 hrs, yielding only slight white precipitates (ca. 1% of the weight of solid (D) used) and yellow solids (E) (from 25g (D)/100 mls C_6H_6) and (F) (from 25g (D)/250 mls C_6H_6).

β) m-Dibenzoylbenzene/m-dibenzylbenzene

m-Dibenzoylbenzene (28.631g, 0.1 mole) and m-dibenzylbenzene (25.834g, 0.1 mole) were dissolved in sodium dried benzene (500 mls, 0.4M with respect to both reagents). The solution was nitrogen streamed for 30 mins, the cylindrical Pyrex tube was quickly stoppered and irradiated at 350 nm for 263 hrs. During irradiation a white material precipitated, whereas remaining solution became bright yellow. The white material (G) was recovered by filtration, washed with a little cold benzene, dried by pumping under reduced pressure, weighed (2.482g) and examined by i.r. spectroscopy (KBr disc); spectrum obtained was the same as the ones recorded for previously obtained white precipitates, described in 2.3.c.iii. The yellow solution separated yielded, following removal of solvent by freeze-drying and pumping under reduced pressure, a yellow material (H) (51.980g) which was spectroscopically examined (i.r., KBr disc); it was then redissolved in benzene (500 mls) and re-irradiated for a further 144 hrs period, yielding another white precipitate (I) (1.044g) and a yellow solid (J) (50.920g).

Solid (J) was then divided into 2 x 25g portions. Two benzene solutions were made:

25g of solid (J) in 100 mls benzene

25g of solid (J) in 250 mls benzene

The two solutions were re-irradiated for 118 hrs, yielding only slight white precipitates, and yellow solids (K) (from 25g (J)/100 mls C_6H_6) and (L) (from 25g (J)/250 mls C_6H_6). Following spectral examinations, solids

(K) and (L) were combined, dissolved in 250 mls of benzene and re-irradiated (350 nm) for 171 hrs, yielding again very slight white precipitates (< 1% of the combined (K) + (L) weight) and a yellow benzene-soluble solid (M) (48.932g).

2.3.d. Characterization of products

All products obtained from experiments described in 2.3.c.iii were dried by pumping under reduced pressure before examination.

I.r. spectra (KBr discs) were the same as the ones obtained for corresponding products described in 2.3.c.i and 2.3.c.ii; spectra of (B), (D), (E), (F), (H), (J), (K), (K), (L), (M), all displayed absorptions at 1660 cm^{-1} , indicating the presence of benzophenone-type carbonyl groups attributable to either unreacted monomer or low molecular weight polymer chains capped with aromatic carbonyl ends.

Products (E) and (F) were combined, dissolved in benzene and the bright yellow solutions thus obtained were added dropwise to a 10-fold excess of 60° - 80° petroleum ether with efficient stirring. A white solid (N) was obtained in 89% yield, which was collected and dried under vacuum. (N) was redissolved in benzene forming a bright yellow solution. Second precipitation from 60° - 80° petroleum ether afforded a white solid (O) (80%) which was dried by pumping under vacuum for 6 days at 40° ; it analyzed as follows: C 86.54, H 7.18 (O) still displayed a weak absorption at 1660 cm^{-1} in the i.r. spectrum. It did not form films on casting on a clean Hg surface (CH_2Cl_2 solvent). Small, brittle fibres were drawn out of the melt; it became tacky between 188° - 207° and melted between 207° - 220° .

Similarly, product (M) was precipitated from benzene/ 60° - 80° petroleum ether yielding a powder (P) (80%) which was dried in the same way as (O). No films were obtained, but small, brittle fibres were drawn out of the melt. (P) became tacky between 165° - 177° and melted between 177° - 192° .

The number average molecular weights of the samples were determined by the isopiestic method in chloroform and are recorded below:

Sample	Total Irr ⁿ time (hrs)	\bar{M}_n	Sample	Total Irr ⁿ time (hrs)	\bar{M}_n
(B)	263	2780	(H)	263	2030
(D)	407	3560	(J)	407	2130
(E)	525	3590	(K)	525	3320
(F)	525	3530	(L)	525	3410
(O)	525	3690	(M)	525	3510
			(P)	696	3670

Polymer characterization was attempted by F.T. ¹H n.m.r. spectroscopy (see Table 2.8).

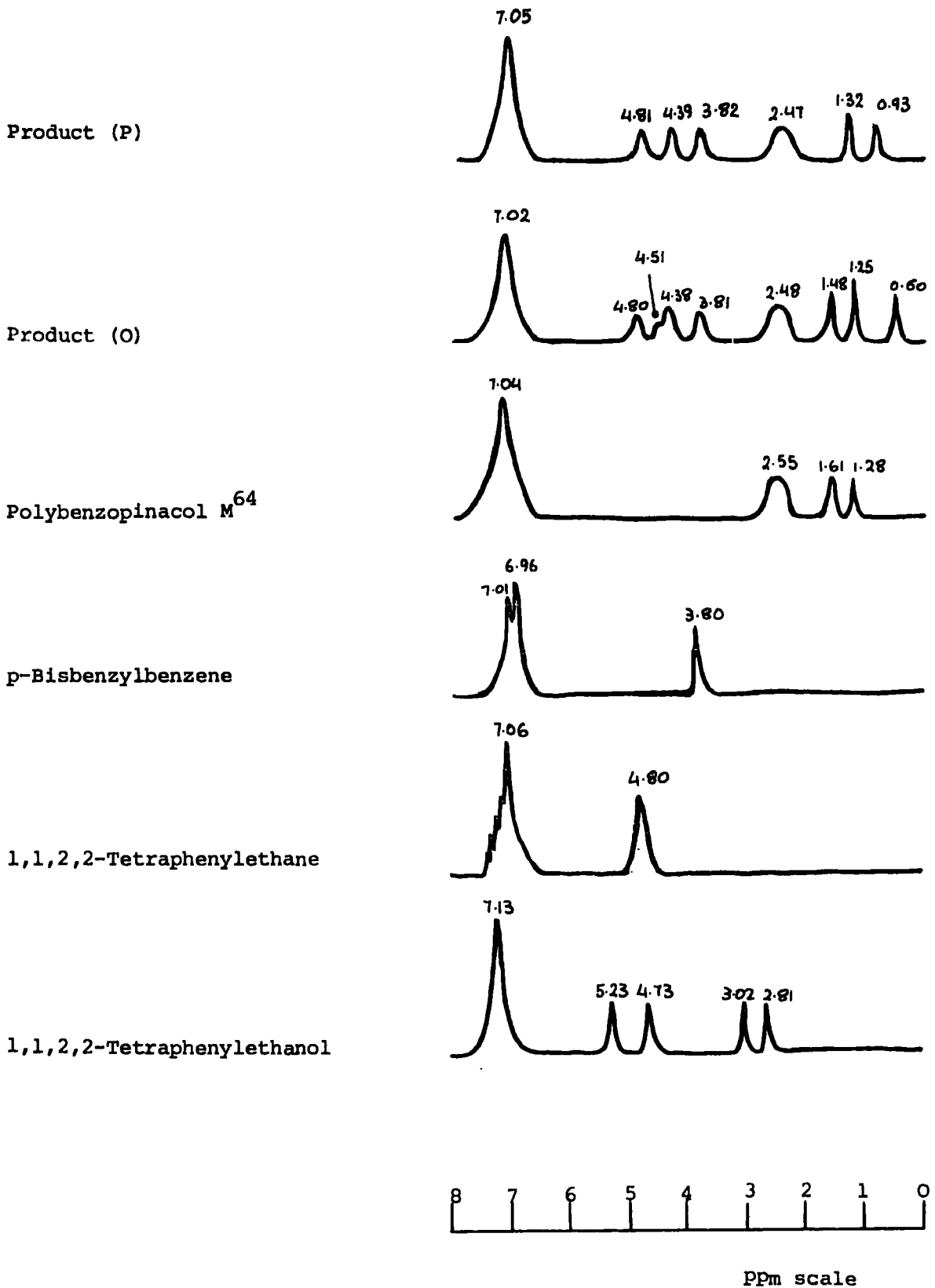
Spectra of samples (O) and (P) were run in CDCl₃ solvent (ext. TMS reference) and compared to the spectra of p-bisbenzylbenzene, polypinacol M,⁶⁴ 1,1,2,2-tetraphenylethanol, benzopinacol and 1,1,2,2-tetraphenylethane.

The first observation was the group of peaks between δ 1.48 - δ 0.60 indicating the presence of occluded solvent containing aliphatic C-H bonds, apparently petroleum ether. Polybenzopinacol M showed similar peaks at δ 1.61, δ 1.28. This observation was somewhat surprising since both (O) and (P) were pumped under reduced pressure for a long time before the spectra were run, and that should have eliminated any occluded volatile materials such as petroleum ether. Evaporation of a large volume of the same batch of petroleum ether used for precipitation of (O) and (P), did not yield any high boiling residues.

Both (O) and (P) displayed peaks at δ 3.81 - δ 3.82 assigned to the methylene protons in the $-C_6H_4-CH_2-C_6H_5$ group, and peaks at δ 4.80 - δ 4.81, assigned to the tertiary hydrogen in a 1,1,2,2-tetraphenylethane type of unit. Broad peaks at δ 4.38 - δ 4.39 however could not be unequivocally assigned to any

Table 2.8

Comparative F.T. ¹H n.m.r. spectra of some phenylated substances
(CDCl₃ solutions, ext. TMS ref.).



structure since the tertiary proton resonance in 1,1,2,2-tetraphenylethanol occurs at δ 5.23 and δ 4.73.

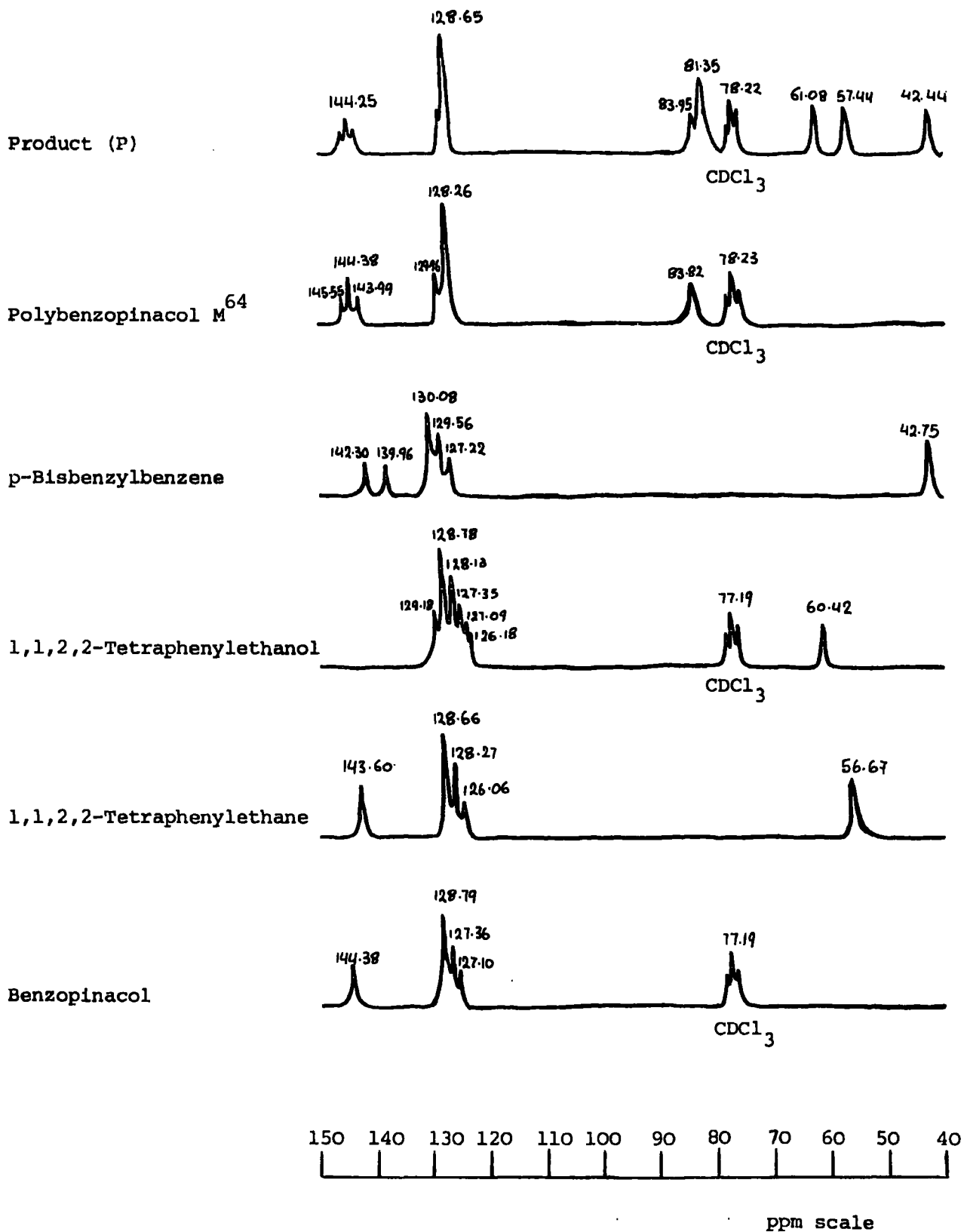
Comparative F.T. ^{13}C n.m.r. spectroscopy proved a more useful technique for the characterization of the materials (see Table 2.9). The triplets observed in the δ 77 to 78 region in some of the spectra are due to the solvent CDCl_3 . They are not seen where it was possible to prepare very concentrated solutions.

Spectrum of (O) showed a group of peaks between δ 144.25 - δ 128.65 assigned to the carbon atoms of the aromatic rings, and peaks at δ 83.95, δ 81.35, δ 61.08, δ 57.44 and δ 42.44. Peaks at δ 57.44 and δ 42.44 were assigned by the sp^3 hybridized carbons in units analogous to 1,1,2,2-tetraphenylethane and bisbenzylbenzene respectively. The peak at δ 83.95 was assigned to the sp^3 hybridized carbon of polybenzopinacol and peak at δ 61.08 to the carbon bonded to hydrogen in the 1,1,2,2-tetraphenylethanol type of unit present in the polymeric material. There remained the peak at δ 81.35 which should correspond to the carbon bonded to the OH group in the 1,1,2,2-tetraphenylethanol type of unit, although it has to be acknowledged that such a peak is not visible in the spectrum of the model compound 1,1,2,2-tetraphenylethanol. This may be a consequence of the very low solubility of the model compound and in practice it was only with considerable persistence in the face of difficulty that a ^{13}C spectrum was recorded.¹⁶³

Thus, combined ^1H and ^{13}C n.m.r. evidence would suggest that, as predicted, the polymeric material contains three major types of groups as shown in Figure 2.56 and also that some polymer ends are capped with benzophenone-type aromatic carbonyl ($\text{C}_6\text{H}_5\text{-C(O)-}$) and benzyl ($\text{C}_6\text{H}_5\text{-CH}_2\text{-}$) groups. In view of this conclusion it is rather surprising that prolonged irradiation did not result in the formation of higher molecular weight products.

Table 2.9

Comparative F.T. ^{13}C n.m.r. spectra of some phenylated substances
(CDCl_3 solutions, ext. TMS ref.).



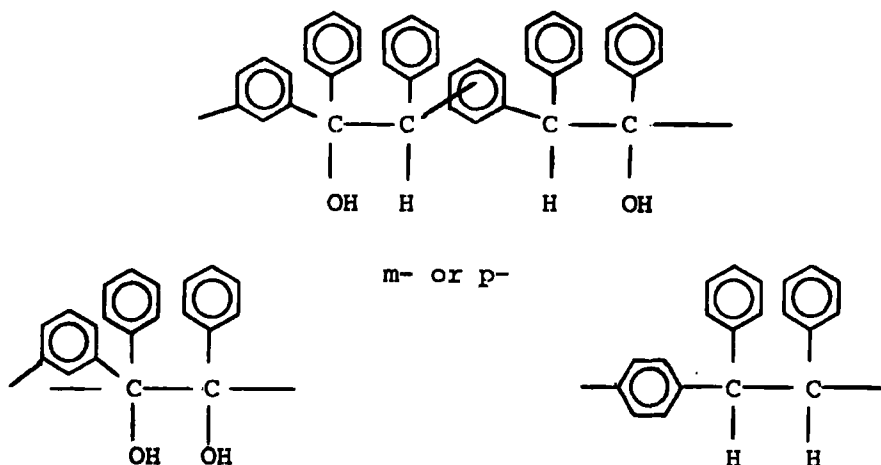


Figure 2.56

2.3.e. Reactions of the polymers

2.3.e.1. Depolymerization

A sample of the polymeric material (O) was introduced into a 3 necked round bottom flask fitted with water condenser, thermometer pocket and nitrogen gas inlet. The flask was slowly heated by means of a free flame until the polymer had melted and then temperature was raised up to 350° and maintained there for 5 mins. A black tar was formed which was left to cool under nitrogen. Examination of the black tar by i.r. spectroscopy gave the following results (contact film, $\bar{\nu}_{\max}$): 3080, 3040, 3020, 2900, 2840, 1660 (strong), 1600, 1580, 1510, 1495, 1450 (doublet), 1430, 1420, 1320, 1300, 1280, 1255, 1205, 1180, 1170, 1120, 1075, 1030, 1000, 985, 910, 850, 830, 800, 780, 720, 710, 700, 640, 620, 600, 485 cm^{-1} . Examination of the black tar by t.l.c. on silica (benzene) revealed the presence of m-dibenzoylbenzene, p-bisbenzylbenzene, diphenylmethane and benzophenone amongst the pyrolysis products.

A similar treatment of polybenzopinacol M (see Tables M (see Tables 2.4 and 2.6) prepared by Andrews and Feast⁶⁴ gave a black tar with a different i.r. spectrum (contact film, $\bar{\nu}_{\max}$): ca. 3480 (broad band), 3299, 3060, 3020, 2920, 1660 (strong), 1660, 1580, 1495, 1445, 1340, 1290, 1270, 1170, 1120,

1075, 1020, 1000, 985, 970, 950, 930, 910, 820, 780, 760, 700, 650, 640 cm^{-1} .

m-Dibenzoylbenzene, m-bisbenzhydrol, benzophenone and benzhydrol were identified amongst the pyrolysis products by t.l.c. on silica (benzene).

These results are consistent with the structures assigned to these materials.

2.3.e.ii. Treatment with dehydrating agents.

The following experiments were performed with product (O)

a) The polymeric material (20.0g) was dissolved in dry benzene (0.5 litres) in a 2 litre 3 necked round bottom flask fitted with gas inlet, reflux condenser and thermometer pocket. Dry HCl was bubbled through the straw-yellow solution at room temperature (26°). After ca. 10 mins the temperature rose to 28° and solution went reddish, progressively darkening to brown-red; temperature stayed constant at 28° after 3 hrs of bubbling. Solution was subsequently refluxed for a further 3 hrs period under an atmosphere of HCl. After cooling to room temperature, a small portion of the solution was taken out, benzene solvent was removed under vacuum and the solid obtained was examined by i.r. spectroscopy (KBr disc). No change was observed, the spectrum being superimposable with that of product (O).

HCl was bubbled through the benzene solution for a further 30 hr period at room temperature. Expulsion of HCl by passing a stream of nitrogen through the solution, removal of the solvent under reduced pressure and precipitation of the solid obtained from benzene/ 60° - 80° petroleum ether yielded a material with the same i.r. spectrum (KBr disc) and melting point as (O).

β) The polymeric material (2.00g) was dissolved in dry benzene (70 mls) in a 250 ml 2 necked round bottom flask fitted with a Dean-Starke apparatus and a reflux condenser. 80 mls of glacial acetic acid and a few drops of concentrated sulphuric acid were added and the solution was refluxed for 4 hrs. After cooling the pot contents down to room temperature, a drop of the solution

was placed on a NaCl plate; pumping under reduced pressure for several hours resulted in the removal of volatile materials and the deposition of a transparent film on the plate, $\bar{\nu}_{\max}$: 3080, 3060, 3030, 2970, 2920-2850 (strong, assigned to traces of apiezon grease extracted by refluxing benzene from the ground glass joints), 1680 (strong), 1600, 1580, 1505, 1495, 1480, 1455, 1445, 1410, 1220, 1180, 1160, 1075, 1035, 1020, 1000, 915, 850, 790, 760, 740, 700, 680, 620 cm^{-1} .

The bulk of the solution was washed with 5% aqueous potassium carbonate, then plenty of water; benzene layer was separated, dried over anhydrous magnesium sulphate and volatile materials were removed under reduced pressure. A grey powder was obtained (1.85g) which was pumped under reduced pressure for 6 hrs at 40°. The solid state i.r. spectrum of the material (KBr disc) was the same as the i.r. of the colourless film described above.

γ) The polymeric material (4.00g) was heated at 250° for 30 mins with an excess of ortho-phosphoric acid. After cooling to room temperature, polymeric material was extracted with benzene. Following washing of the benzene layer with aqueous potassium carbonate, then plenty of water and drying over anhydrous magnesium sulphate, a drop of the benzene solution was placed on a NaCl plate; the thin film deposited after evaporation of solvent under reduced pressure was examined by i.r. spectroscopy; $\bar{\nu}_{\max}$: 3080, 3060, 3030, 2910, 1660 (strong) 1600, 1575, 1510, 1490, 1470, 1445, 1430, 1340, 1280, 1250, 1170, 1155, 1110, 1075, 1030, 1020, 1000, 980, 915, 850, 790, 765, 730, 710, 700, 680, 640, 620, 555, 490 cm^{-1} .

δ) Product (O) (3.00g) was dissolved in 80 mls of dry benzene; 90 mls of glacial acetic acid and a small crystal of iodine was added and the solution was treated successively with an excess of water, dilute aqueous potassium carbonate, water again, 5% thiosulphate solution, and further water. The yellow benzene layer was dried over anhydrous magnesium sulphate, then volatile materials were removed by pumping under reduced pressure and a yellowish powder

was obtained (3.85g) which was precipitated from benzene/60°-80° petroleum ether (white powder, 80%). I.r. examination (KBr disc) showed the presence of a weak O-H band and a weak band at 1680 cm⁻¹.

Refluxing the same solution for 4.5 hrs followed by exactly the same treatment yielded 80% of a whitish powder with the following i.r. absorptions (KBr disc, $\bar{\nu}_{\max}$): 3080, 3060, 3030, 2920, 1680 (strong), 1600, 1580, 1505, 1495, 1480, 1445, 1410, 1220, 1180, 1160, 1075, 1035, 1020, 1005, 915, 860, 840, 790, 765, 740, 700, 680, 620 cm⁻¹. This i.r. spectrum was found to be very nearly superimposable to the one obtained from experiment β .

e) The polymeric material (1.20g) was dissolved in dry benzene (100 mls); toluene p-sulphonic acid (0.80g) was added and the solution was refluxed for 30 mins. After cooling, benzene was washed with aqueous potassium carbonate (5%), then water and dried over anhydrous magnesium sulphate. Removal of the solvent under reduced pressure yielded 1.09g of a material whose i.r. spectrum was found to be superimposable with the one obtained for products from experiments β and δ . The same result was obtained when the experiment was carried out stirring the polymer/toluene p-sulphonic acid solution at room temperature for 4 hrs.

Finally, heating the polymer with an excess of conc. sulphuric acid for 30 mins. gave water soluble tars, whereas refluxing with P₂O₅ in xylene for 2 hrs gave a material displaying various types of carbonyl bands in the infrared, including one at 1660 cm⁻¹.

2.3.e.iii. Parallel model compound studies

a) 1,1,2,2-tetraphenylethanol (2.00g, 0.0057 mole) in hot glacial acetic acid (150 mls) was boiled under reflux for 1 hr in the presence of a crystal of iodine. After cooling, solution was treated successively with water (50 mls), 0.1M aqueous potassium carbonate (50 mls), dilute aqueous thiosulphate (30 mls) and water (50 mls). A yellowish precipitate was obtained which was dissolved

in benzene (100 mls) and kept over anhydrous magnesium sulphate overnight. Following removal of benzene solvent and drying under reduced pressure, the yellowish material (1.82g) was examined by i.r. spectroscopy (KBr disc, $\bar{\nu}_{\max}$): 3075, 3060, 3020, 1680, 1600, 1580, 1490, 1445, 1340, 1320, 1280, 1185, 1175, 1160, 1075, 1030, 1015, 1000, 980, 945, 925, 840, 780, 760, 745, 700, 655, 635, 629, 620, 610, 575, 470 cm^{-1} . Examination of the product by t.l.c. on silica (benzene) showed the presence of tetraphenylethylene, benzopinacolone and 1,1,2,2-tetraphenylethane. Recrystallizations of the product from chloroform/methanol afforded a yellowish material in the form of elongated plates, single spot on t.l.c. on silica (benzene), m.pt. 220^o-221^o, having the following i.r. spectrum (KBr disc, $\bar{\nu}_{\max}$): 3079, 3065, 3020 (doublet), 1600, 1575, 1490, 1445, 1190, 1160, 1080, 1035, 1005, 985, 920 (triplet), 780, 765, 750, 700, 630, 620, 575, 470, 450 cm^{-1} . Recrystallization of the product from benzene/ethanol gave 1.5g of a white crystalline solid, m.pt. 222^o-223^o. The i.r. spectrum of the crystalline solid was found to be superimposable with the one recorded for the product obtained from similar treatment of 1,1,2,2-tetraphenylethanol, and is therefore tetraphenylethylene, m.pt. 223^o-224^o (benzene/ethanol).¹⁴⁰

β) 1,1,2,2-tetraphenylethanol (10.00g, 0.028 mole) in hot benzene (200 mls) was boiled under reflux for 3 hrs in the presence of P₂O₅ (20.00g). After cooling, benzene solution was filtered and excess P₂O₅ was destroyed by careful addition of water. Evaporation of the benzene solvent yielded a white material (9.0g) displaying no O-H band but C-H aliphatic and benzopinacolone-type carbonyl bands in the i.r. region (KBr disc). Recrystallizations of the white material from chloroform/methanol and benzene/ethanol yielded ca. 7g of pure tetraphenylethylene, m.pt. 223^o-224^o, identified by solid state i.r. spectroscopy (KBr disc) and mass spectrometry (m/e extended to 332 corresponding to the parent ion. The mother liquors from recrystallizations were found by t.l.c. on silica (benzene) to contain benzopinacolone and 1,1,2,2-tetraphenylethane.

1,1,2,2-tetraphenylethanol was recovered unchanged after being boiled under reflux (1 hr) in either benzene or toluene (0.028M). Traces of benzophenone and diphenylmethane were observed on t.l.c. on silica (benzene), resulting probably from partial thermal decomposition of the ethanol.

Refluxing an equimolar toluene solution of benzopinacol and 1,1,2,2-tetraphenylethane (0.1M with respect to both reagents) for 3 hrs resulted in total consumption of both starting materials and formation of 1,1,2,2-tetraphenylethanol, identified by t.l.c. on silica (benzene) and i.r. spectroscopy (KBr disc). Traces of benzophenone, diphenylmethane and benzhydrol were also observed on the t.l.c. plates.

Finally, heating 1,1,2,2-tetraphenylethanol under nitrogen at 350° for 5 mins (round bottom flask, free flame) resulted in total decomposition of the material and quantitative formation of benzophenone and diphenylmethane, identified by t.l.c. on silica (benzene) and i.r. spectroscopy (contact film).

2.3.f. Experimental

2.3.f.i. Readily available materials

The origin and purification procedure (where appropriate) for benzophenone, m-dibenzoylbenzene and NaBH_4 used in this have already been described in 2.2.j.

Vitride ($\text{NaAlH}_2(\text{OCH}_2\text{CH}_2\text{OCH}_3)_2$ 70% benzene solution) was purchased from Aldrich Chemicals Ltd. and used as obtained.

Diphenylmethane was purchased from BDH Laboratory Reagents. It was distilled twice from a short column and then fractionated under nitrogen (760 mmHg, 264° - 266°). In a second fractionation under an atmosphere of nitrogen at 760 mmHg, product distilling at 266° was collected in a dry flask (lit.¹⁶⁴ $265.6^\circ/760$ mmHg). The material was a single component by t.l.c on silica (benzene, ethanol, acetonitrile, carbon tetrachloride); the i.r. spectrum was recorded (contact film, $\bar{\nu}_{\text{max}}$): 3080, 3060, 3020, 2900, 2840, 1600, 1580, 1490, 1450, 1430, 1380, 1320, 1200, 1180, 1155, 1110, 1075, 1030, 940, 920, 890, 845, 810, 785, 700, 610, 550, 460, 445 cm^{-1} . The pure compound crystallized slowly on standing forming big colourless prisms, m.pt. 26° - 27° (lit.¹⁶⁴ 26° - 27°).

Benzhydrylchloride was obtained from departmental stock. It was distilled twice under nitrogen before use; the fraction distilling between 170° - $176^\circ/20$ mmHg was collected (b.pt.¹⁶⁴ $173^\circ/19$ mmHg).

Terephthalaldehyde was purchased from Koch-Light Laboratories Ltd. and recrystallised twice from methanol/water 70:30. White needles obtained gave a single spot on t.l.c. on silica (benzene, chloroform) and melted at 117° (lit.¹⁶⁴ 116°). The mass spectrum extended to $m/e = 134$ corresponding to the parent ion; main peaks at 133, 105, 84, 77, 57, 51.

2.3.f.ii. Solvents

Benzene was purified as described in 2.2.j.ii; THF (freshly distilled) was obtained from departmental stock and used immediately; pyridine and

toluene (Analytical grades) were obtained from BDH Laboratory Reagents and used without further purification; isopropanol (technical grade) was obtained from Fisons Laboratory Reagents Ltd.; it was purified by fractional distillation prior to use.

2.3.f.iii. Materials synthesized from simpler chemicals

1,1,2,2-tetraphenylethane was prepared by the Wurtz coupling of alkyl-halides:^{157,158}

Re-distilled benzhydrylchloride (10.125g, 0.05 mole) was dissolved in sodium-dried diethylether (500 mls) in an 1 litre round bottom flask equipped with nitrogen inlet, double surface reflux condenser (leading to a concentrated sulphuric acid bubbler), and mechanical stirrer.

Thinly sliced sodium (4.6g, 0.2 mole) was added and flask contents were stirred at room temperature for 24 hrs under an atmosphere of nitrogen, and then refluxed for a further 12 hr period. After cooling, the ethereal solution was filtered and excess sodium was carefully destroyed using isopropanol. Ether was removed under reduced pressure and a white solid was obtained consisting of 1,1,2,2-tetraphenylethane, diphenylmethane and benzhydrol (t.l.c. on silica, benzene). After several recrystallizations from ethanol and acetic acid, 1,1,2,2-tetraphenylethane was isolated in a pure state as shown by t.l.c. on silica (benzene, chloroform, ethanol) in 85% yield, m.pt. 213° (lit.¹⁶⁴ 212.5°). Lassaigne's test on the product showed that chlorine was absent.

2.3.g. Discussion and Conclusions

The bisbensophenone/bisbenzylbenzene photopolymerization was found to be similar to the model reaction in some respects, e.g. the slow reaction rate, the early appearance of the yellow colour during irradiations and the formation of products containing three main types of unit as shown in Figure 2.56.

However some new questions have arisen:

a) the origin and structure of the white insoluble precipitates obtained in all photoreaction,

β) the failure of the polymer forming reaction to proceed to completion even at prolonged irradiations, contrary to the behaviour of the benzophenone/diphenylmethane system and despite the presence of unreacted $-C_6H_4-CH_2-C_6H_5$ and $-C_6H_4-C(O)-C_6H_5$ residues in the polymeric materials, detected by n.m.r. and i.r. spectroscopy.

γ) the slower rate of molecular weight increase observed for the m-dibenzoylbenzene/m-dibenzylbenzene system, relative to the corresponding m-/p- one, although both systems gave materials of roughly the same molecular weight after 525 hrs of irradiation (see p. 124).

A typical i.r. spectrum of the white precipitate from the above photo-reactions has already been described in 2.3.c.ii. Attempts to measure \bar{M}_n of such materials in solution failed due to extremely low solubility in a wide variety of solvents. Similarly, low solubility in deuterated solvents prevented examination by n.m.r. spectroscopy. It is possible that white precipitates might be either branched or crosslinked materials, formed by the interaction of a photoexcited bisbenzophenone carbonyl and tertiary hydrogen in either a 1,1,2,2-tetraphenylethanol type of unit or a 1,1,2,2-tetraphenylethane type unit, as shown in Figure 2.57 (in the case of branching).

The failure of the polymerization reaction to proceed to completion is a difficult question to deal with. In particular the established presence of both benzoyl and benzyl groups in the reaction products rules out the possibility of one type of functional group being totally consumed by some kind of side reaction, thus leaving the other in excess. One could attribute this phenomenon to the formation of either an efficient triplet quencher or a strong light absorbing intermediate which does effectively stop the reaction at a particular stage.

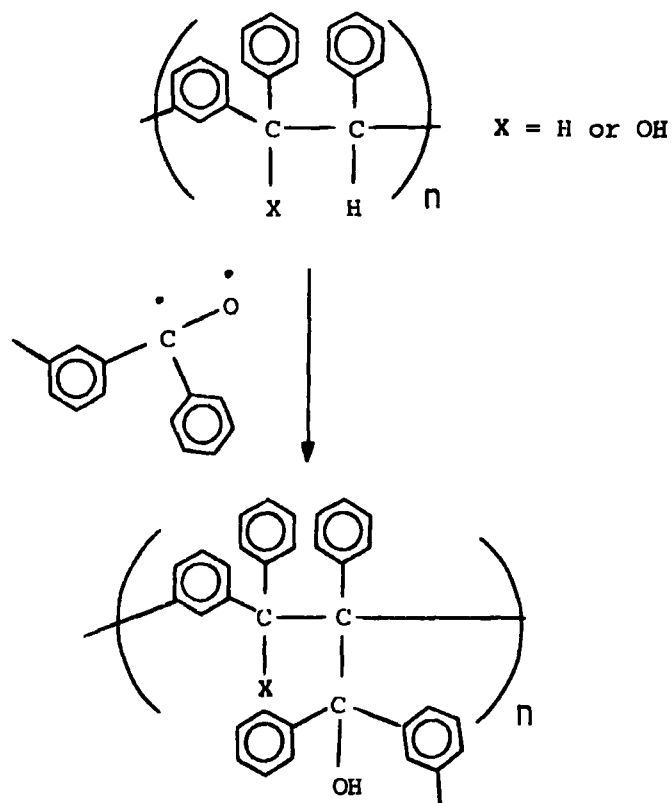


Figure 2.57

The origin of the yellow colour observed during irradiations is difficult to account for. Precipitation of the yellow crude polymeric materials from benzene/60°-80° petroleum ether afforded white powders whose i.r. spectra and \bar{M}_n were not different from those of the crude materials. Treatment of the white powders with benzene at room temperature resulted in the formation of bright yellow solutions. Evaporation of benzene solvent gave yellow materials, whereas addition of excess 60°-80° petroleum ether to the yellow benzene solutions caused the precipitation of white materials; the i.r. spectra of these products were superimposable. It was first thought that some kind of association between benzene solvent and the product occurs which gives rise to

the coloured species. However the same cycle of colourless to yellow changes can be effected using chloroform, which excludes such an explanation.

Treatment of the polymeric materials with dehydrating agents eliminated the hydroxyl peak in the i.r. region and gave rise to a new peak at 1680 cm^{-1} attributed to a benzopinacolone-type carbonyl group. This was observed both in reactions carried out at high temperature and room temperature, and is consistent with the expected reaction scheme shown in Figure 2.58. The

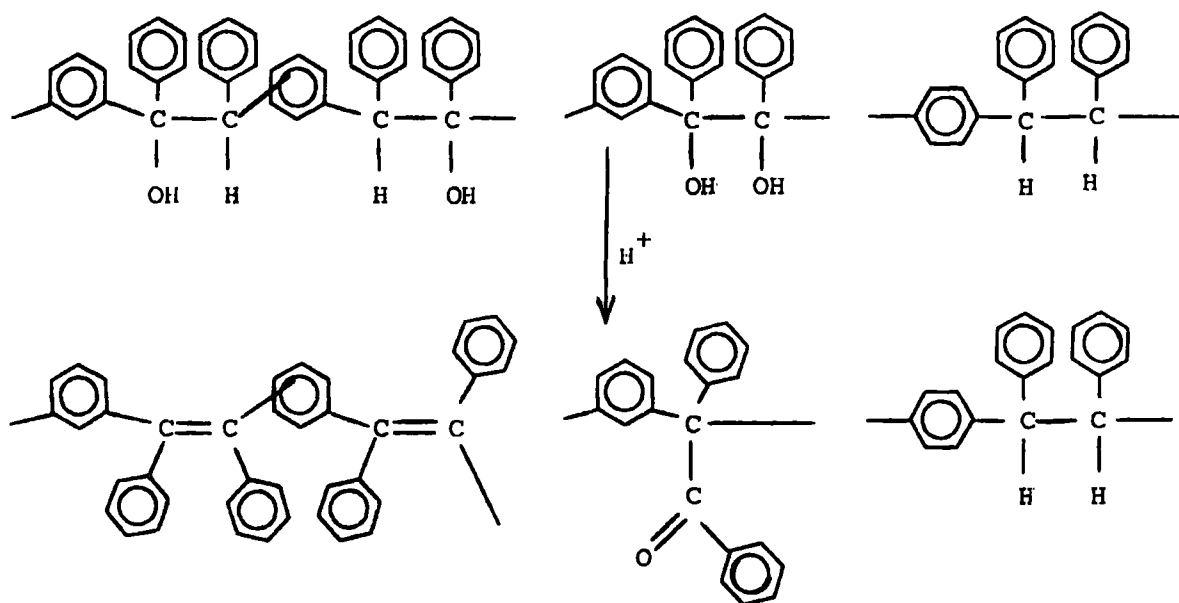


Figure 2.58

1,1,2,2-tetrahydroxyethane type of unit would be expected to lose HOH giving a conjugated structure; the benzopinacol type of unit would be expected to rearrange to a benzopinacolone one¹⁶⁵ and the 1,1,2,2-tetrahydroethane structure would be expected to be unreactive.

The model compound 1,1,2,2-tetrahydroxyethane appears to be partially dissociating at temperatures of ca. 80° or over yielding radicals by rupture of the ethane C-C σ bond. In the absence of dehydrating agents these radicals appear to recombine forming the initial product, or diffuse out of the cage

and dimerize yielding benzopinacol and 1,1,2,2-tetraphenylethane, all the steps are reversible and since the ethanol derivative is very insoluble, it is normally the predominant product. Addition of dehydrating agent at high temperatures causes the rearrangement of the benzopinacol component of this system to benzopinacolone (Figure 2.59). This hypothesis would explain

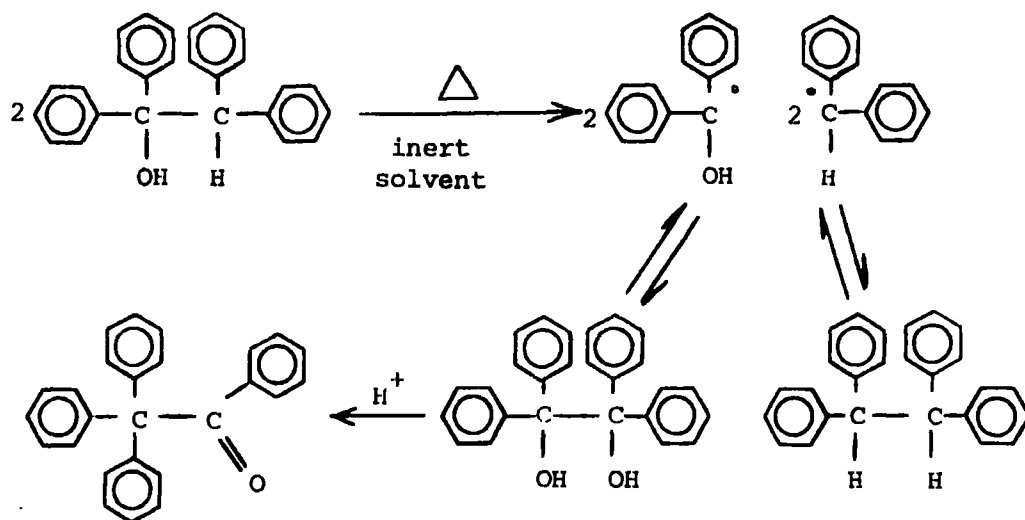


Figure 2.59

the observed behaviour of the ethanol and its formation from benzopinacol and tetraphenylethane. At room temperature 1,1,2,2-tetraphenylethanol is known to dehydrate quantitatively to tetraphenylethylene (perchloric acid/methylenechloride solvent), no by-products were reported.¹⁶⁶

It can be concluded that the photoreductive addition of *m*-dibenzoylbenzene to *p*- or *m*-dibenzylbenzene at 350 nm leads to the formation of low molecular weight materials (\bar{M}_n ca. 3500) containing units analogous to 1,1,2,2-tetraphenylethanol, benzopinacol and 1,1,2,2-tetraphenylethane. In contrast to the model reaction, polymerization does not proceed to completion even at prolonged (over 700 hrs) irradiations. The products obtained decompose

thermally at high temperatures to yield starting materials together with traces of diphenylmethane and benzophenone. Treatment with dehydrating agents results in the elimination of water and the occurrence of rearrangements, both results being entirely consistent with the structures assigned to the polymers.

It would seem on the basis of the results obtained in this work that truly successful photoreductive polymerization is likely to be limited to the case of benzopinacols, although the history of the area suggests that it would be foolish to make dogmatic statements to this effect.

CHAPTER 3

The products of irradiation of benzaldehyde and its difunctional analogues

3.1. Introduction

3.1.a. Early photochemical investigations

Investigations into the nature of the products formed on exposing benzaldehyde, either neat or in the presence of other substances to actinic radiation go back to the beginning of the century. In 1901, Ciamician and Silber insolated a mixture of benzaldehyde and ethanol in a sealed glass tube;¹²⁷ they obtained acetaldehyde, a resin, and an unspecified quantity of hydrobenzoin. Steam distillation of the resin gave quantities of materials described as 'benzoic ether', 'isohydrobenzoin' (the two forms of hydrobenzoin reported may have been the dl- and meso-diastereomers), and a 'yellow, hard and fragile material' which was separated, dried and precipitated from benzene/petroleum ether. A white powder was thus obtained melting at 100° - 101° ; it was found to have the same composition as hydrobenzoin but a molecular weight four times as high. On the basis of these findings the authors assigned to the white powder the formula $4(C_{14}H_{14}O_2)$. Similar results were obtained on insolation of an ethereal solution of benzaldehyde.¹²⁷

Five years later the same workers reported results from the insolation of neat benzaldehyde in a sealed glass tube for a period of over 8 months.¹²⁸ The reaction product was described as a translucent mass similar to 'greek pitch' which is a deep red varnish; a few crystals of benzoic acid were observed on the walls of the tube. The translucent mass was extracted with ether and steam distilled to yield a little unreacted benzaldehyde and a yellow resin which, after repeated treatments with boiling water and drying, gave a 'fragile material'. Following treatment of an ethereal solution of the resin with aqueous carbonate and reprecipitation from benzene/petroleum ether a white powder was obtained which was found to become tacky at 120° and melt between 125° - 130° . Elemental analyses and molecular weight determinations in benzene gave results pointing to the formula $9C_7H_6O$. Ciamician and Silber suggested that the resin obtained from the insolation of neat benzaldehyde might in fact be identical to

the one obtained from the insolation of the benzaldehyde/ethanol mixture; the difference in the empirical formulae, they proposed, might just be due to difficulties inherent in the analysis of amorphous substances.¹²⁸

Insolation of a benzaldehyde/benzylalcohol mixture (10g, 1:1 ^{w/w}) for 5 months afforded small quantities of hydrobenzoin and isohydrobenzoin and 4.4g of a resin apparently the same as that already described.¹³¹ On the other hand, insolation of a benzaldehyde/benzophenone mixture (15g, 2:1 ^{w/w}, 3 months) resulted in the formation of a resin and small quantities of a white crystalline material which, following extraction and purification from acetic acid melted at 236° - 237° and analysed as follows: C, 81.02; H, 5.65 (calculated for C₄₁H₃₄O₅: C, 81.18; H, 5.61). On the basis of these results the authors assigned to the crystalline product the formula C₄₁H₃₄O₅,¹²⁸ corresponding to an adduct between four molecules of benzaldehyde and one of benzophenone. Ciamician and Silber also investigated the products formed on insulating a benzaldehyde/nitrobenzene mixture.¹⁶⁷ Two compounds were isolated assigned the

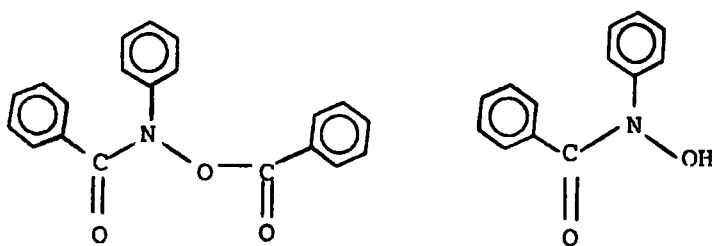


Figure 3.1

structures shown in Figure 3.1 along with some resin melting at 125° - 130°.

In an attempt to prepare novel compounds containing nitrogen - iodine bonds, Mascarelli insolated a benzaldehyde/iodoxybenzene (C₆H₅IO₂) mixture (250g, 5:1 ^{w/w}, 10 months, sealed tube).¹⁶⁸ The yellow-brown product was treated with ether, leaving a whitish residue (ca. 2g, m.pt. 240° - 245°) which was recrystallized from acetic acid to give well defined white crystals melting at 250°. This product was slightly soluble in most ordinary solvents and was found

to have the same composition as benzaldehyde and a molecular weight three times as high. The author described this new compound as a 'trimer of benzaldehyde' without further examining its properties. Other products isolated and characterized were benzoic acid, stilbene, iodobenzene, traces of iodine and the usual resin melting between 125° - 130° ; several high boiling liquids were also obtained which were not identified. The interesting feature of this experiment in the author's view¹⁶⁷ was the formation of the resin and the crystalline 'trimer' on insolation of benzaldehyde in the presence of an oxidizing agent ($C_6H_5IO_2$).

Three years later, Ciamician and Silber reinvestigated the insolation of neat benzaldehyde¹⁶⁹ in order to establish whether the 'trimer' described by Mascarelli¹⁶⁸ did in fact form in the absence of iodinated compounds or not. Neat benzaldehyde (100g) was insolated in a sealed tube for over 29 months so that the reaction could proceed to completion. At the end of the irradiation period an almost solid red-brown material had formed inside the tube, together with a few drops of water. This experiment afforded 0.8g of the 'trimer' described by Mascarelli (m.pt. 245° - 246° (acetic acid)) separated by virtue of its insolubility in diethylether, ca. 12g of an oil (boiling between 177° - 200°) composed mainly of benzaldehyde, small quantities of benzoic acid and hydrobenzoin, and 82.5g of the resin already described in previous experiments.^{127,128,131,167} The resin was redissolved in ether, treated with aqueous sodium carbonate, then the ethereal layer was separated and dried over calcium chloride. Precipitation from petroleum ether yielded a yellowish amorphous material; a portion of it was precipitated several times from benzene/ 40° - 70° petroleum ether until a white powder was obtained which, after drying at 100° melted between 160° - 170° . This material was found to have the same elemental composition as benzaldehyde and molecular weight determination in acetic acid indicated a tetramer. This 'tetramer' of benzaldehyde was reactive towards phenylhydrazine and semicarbazide hydrochloride; treatment with semicarbazide

hydrochloride in acetic acid afforded a compound with an elemental composition corresponding to the formula $C_{29}H_{27}O_4N_3$ melting at 232° which the authors assigned to the semicarbazone of the tetramer $4C_7H_6O$. On the basis of this evidence they proposed the structural formula shown in Figure 3.2 for the photoproduct of benzaldehyde.

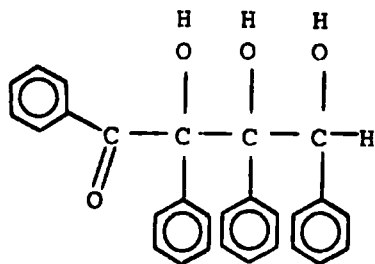


Figure 3.2

The insolation of benzaldehyde in the presence of aliphatic hydrocarbons was examined by Paternò and Chieffi.¹¹⁹ They reported obtaining the resinous product already described by Ciamician and Silber in addition to the 'trimer' described by Mascarelli. Heating the 'trimer' in sealed tubes at 300° resulted in the formation of benzaldehyde whereas the amorphous resin gave under identical treatment a tarry liquid; no inflammable gases or volatile liquids were observed. Distillation of the tarry liquid afforded benzaldehyde and a high boiling fraction which crystallized on standing and was identified as hydrobenzoin by melting point determination.

In 1914, Ciamician and Silber repeated the insolation of a benzaldehyde/benzophenone mixture and isolated a compound melting at 245° whose elemental analysis and molecular weight determination suggested that it could be the 'addition product' of the two reagents ($C_{27}H_{22}O_3$),¹⁷⁰ that is an adduct of two molecules of benzaldehyde with one of benzophenone.

The reports on these early investigations are confusing. Paternò did not miss the chance to indulge in scornful criticism of Ciamician and his team for what he considered to be their inaccurate and inconsistent reports on the resinous product formed on insolation of benzaldehyde, 'which melted initially

at 100° - 101° then at 125° - 130° and now melts at 160° - 170° and which was initially an octamer or nonamer of benzaldehyde and it is now recognized as a tetramer'.¹³⁴

However confusing they might be, these early experiments represent the only reported attempts to investigate the structure of this 'resin' formed on irradiation of benzaldehyde. In subsequent years the preparative photochemistry of benzaldehyde in the presence of a wide variety of substances was examined by various workers; it was found to photooxidize yielding benzoic acid, add to unsaturated linkages, quinones or methylene groups, abstract hydrogen from suitable donors etc. A comprehensive review of these processes may be found in standard texts such as the one by Schönberg.¹⁶⁷ The reactions are generally consistent with the expected behaviour of a triplet excited carbonyl group linked to an aromatic ring. Finally, the 'resin' reported by the early workers was recently prepared by the gas phase irradiation of benzaldehyde at $\lambda > 300\text{nm}$ and was found to possess interesting photophysical properties; no attempts to elucidate its structure were however reported.¹⁷¹

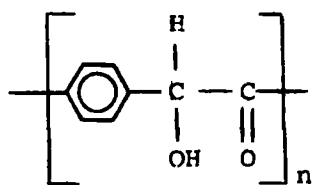
3.1.b. Ground state polymerization of benzaldehyde and its difunctional analogues

Benzaldehyde was found not to polymerize under the action of γ -irradiation or by treatment in solution or in bulk with a wide range of cationic initiators.¹⁷² However, when benzaldehyde was heated with borontrifluoride etherate at 150° in the absence of solvent a polymeric product was formed in low yield (1.4%). It was relatively non-polar and fluorescent softening at 79° and melting at 88° . Compression moulding at 90° gave a glossy, brittle disc. The product contained neither boron nor fluorine; ebulliometric determinations both in carbon tetrachloride and in benzene indicated a polymer of d.p. 133. The polymer was identified as polybenzyl on the basis of elemental analysis and infrared spectroscopy.¹⁷² Mixtures of benzaldehyde and styrene treated at 0° with borontrifluoride etherate copolymerized through the carbonyl group of benzaldehyde to yield a product isosteric with polystyrene but which may not have a definite

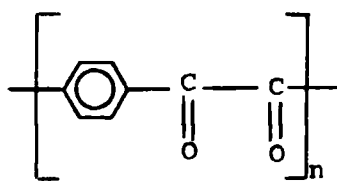
repeat unit. Elemental analysis of the copolymer produced from a 50:50 mixture of monomers indicated a product incorporating approximately 80% styrene and 20% benzaldehyde, and having a molecular weight of 14,600.

Both iso- and tere-phthalaldehyde have been polymerized under a variety of conditions to give benzoin copolymers,^{173,174} which are claimed to be very useful as coatings which can be cross-linked to form binders for glass-fabric laminates. The copolymers were said to possess excellent thermal stabilities and tear strength.¹⁷⁴ Terephthalaldehyde has also been polymerized in the presence of ketene and borontrifluoride etherate,¹⁷⁵ and DMSO.¹⁷⁶ The latter method yielded a pale yellow powder of d.p. < 9, soluble in DMSO, DMF and ethylene carbonate, identified by i.r. spectroscopy as polybenzoin (Figure 3.3,I); autooxidation in DMSO solution gave the high-melting and insoluble polybenzil (Figure 3.3,II).¹⁷⁶

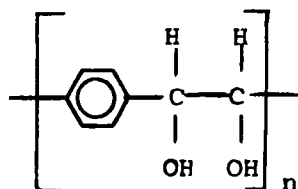
Reduction of terephthalaldehyde in dioxane with Zn and $\text{Cr}_2(\text{SO}_4)_3$ afforded poly(p-phenylenebis(hydroxymethylene)) (Figure 3.3,III). Treatment of this polymer with HNO_3 resulted in the formation of poly(p-phenylenedicarbonyl), i.e. polybenzil.¹⁷⁷ Condensing the polycarbonyl with o-phenylenediamine and/or



I



II



III

Figure 3.3

3,3',4,4'-tetraminobiphenyl yields heat resistant resinous polyquinaxolines useful in the preparation of protective coatings and laminated resins having heat stability, solvent resistance, flexibility and low softening points.¹⁷⁷ Copolymers of terephthalaldehyde with various substances like ferrocene,¹⁷⁸ poly(vinylalcohol)¹⁷⁹ and polyamide acids¹⁸⁰ have been reported. Fairly recently, selective chemical reactions on one aldehydic group of tere- and iso-phthalaldehyde were made possible by use of polymer supports.¹⁸¹

3.1.c. The photochemistry of phthalaldehyde

Schönberg and Mustafa reported that a benzene solution of phthalaldehyde exposed to sunlight for 1 day deposited colourless crystals of a dimer, m.pt. ca. 184° (decomposition) (Figure 3.4).¹⁸²

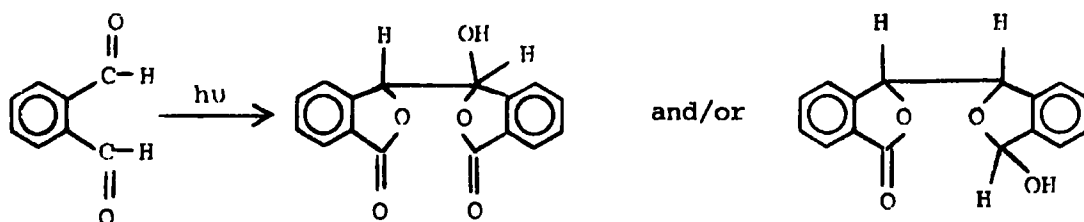


Figure 3.4

Kagan irradiated phthalaldehyde (200 mg) in carbon tetrachloride (50 mls) for 1 hr. under nitrogen and reported obtaining crystalline phthalide, i.e. the lactone of 2-hydroxymethylbenzoic acid, m.pt. 70° in ca. 80% yield.¹⁸³ He obtained similar results at different concentrations, in the presence of air, and with irradiation at either 253.7nm or 350nm. On the other hand, he showed that irradiation of phthalaldehyde (0.727g) in pentane (250 mls) at 350nm for 1 hr. (N_2 atmosphere) yielded 67% of the pure photodimer shown in Figure 3.5; and

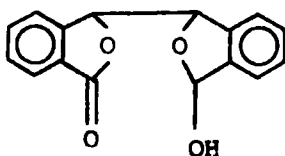


Figure 3.5

irradiation of neat phthalaldehyde (N_2 atmosphere) at 350nm for 3 hrs. yielded phthalide (15%), the photodimer (55%), and 30% of unchanged starting material. Finally, irradiation of phthalaldehyde (0.172g) in benzene (50 mls) at 350nm under N_2 atmosphere gave phthalide (45%) the dimer (51%) and unchanged starting material (4%).¹⁸³ The lack of dimer formation in chlorinated solvents was attributed by Kagan to efficient quenching of the dimerization step in the proposed mechanism by Cl^\bullet radicals from the solvent. This was the first example of a photochemical Canizzaro reaction in which both photo-oxidation and -reduction was shown to occur simultaneously on irradiation of an aldehyde.

Cohen and co-workers showed that the dimerization of phthalaldehyde is stereospecific in contrast to the dimerization of o-phthalaldehydic acid (2-formylbenzoic acid) which is non-stereospecific; the reactions proceed via two quite different paths.¹⁸⁴

Further work by Kagan¹⁸⁵ on the photolysis of phthalaldehyde at 77K pointed to the conclusion that a benzoyl radical intermediate was involved in the reaction which was assumed to proceed from a short lived phthalaldehyde excited state to form phthalide and/or the photodimer.

3.1.d. Brief introduction into the photochemistry of benzaldehyde

Benzaldehyde, one of the few molecules which exhibit phosphorescence in the gas phase^{186,187} has been extensively used as a triplet energy donor both in the gas phase¹⁸⁸ and in solution.^{189,190} The molecule has been the object of numerous theoretical and spectroscopic studies and a substantial amount of data appear in the literature.¹⁹¹

Direct photolyses of gaseous benzaldehyde reported upto the early seventies have only been preliminary in nature.¹⁹²⁻¹⁹⁵ It was established that $n \rightarrow \pi^*$ excitation in the gas phase resulted in polymer formation on the cell wall and that at elevated temperatures the quantum yield of benzaldehyde consumption was as high as 40.¹⁹⁵ It was also reported that at $\lambda < 270\text{nm}$ benzaldehyde

decomposed to benzene and carbon monoxide.¹⁹⁴ Blacet and Vanselow¹⁹⁴ claimed that hydrogen gas, benzil, benzophenone and diphenyl were formed in addition to benzene and carbon monoxide upon irradiation of benzaldehyde at 313nm.

In an attempt to obtain absolute quantum yields for the primary photo-physical and photochemical processes and to study the effect of wavelength on the system, Steel and coworkers carried out a detailed examination of the photo-chemistry of benzaldehyde.¹⁹⁶ The quantum yields of benzene and carbon monoxide formation, benzaldehyde consumption and phosphorescence emission were studied. These data, together with information from following the phosphorescence life-time over a range of pressure and excitation wavelengths, and triplet transfer studies allowed a picture of the primary photophysical processes to be built up (Figure 3.6) and rate constants for these processes to be determined. The authors interpreted their data as indicating that with 276nm light, $S_0 \longrightarrow S_2$ excitation, resulted in the population of the higher vibrational levels of two different triplet states (T_1 and Γ). At low pressures, dissociation occurs from both these vibrationally excited triplets yielding benzene and carbon monoxide.

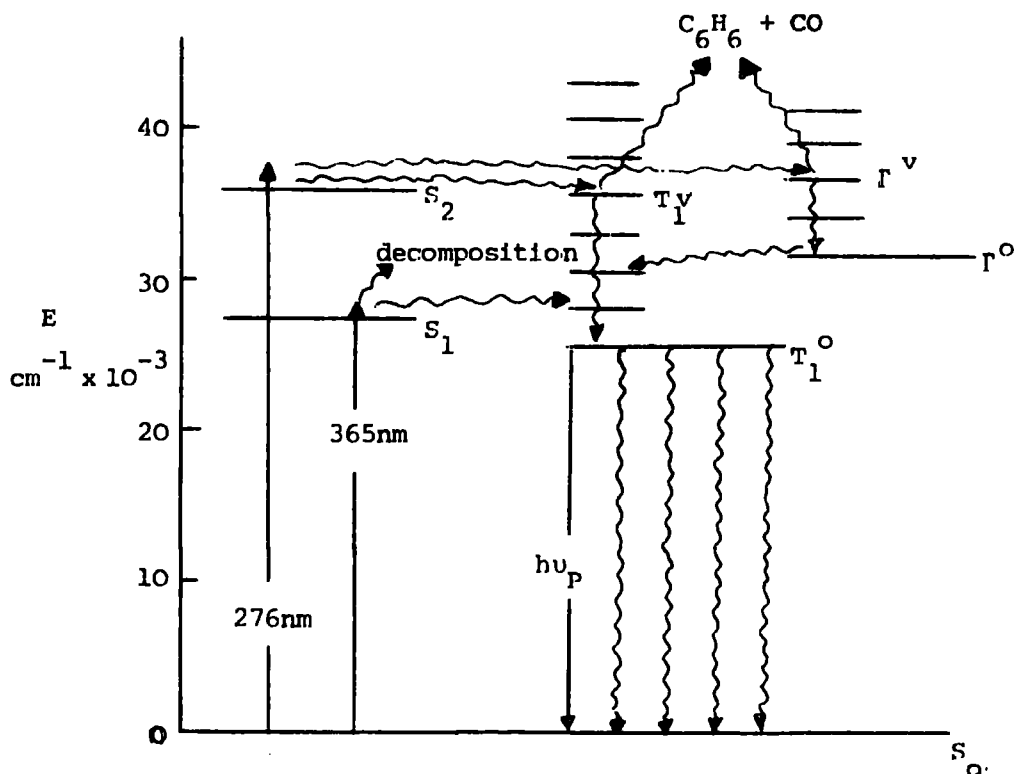


Figure 3.6¹⁹⁶

Collisional deactivation of these states feeds the lower vibrational levels of the lowest triplet; from here there are no chemical decay channels and phosphorescence can be observed. In contrast to $S_0 \longrightarrow S_2$ excitation, $S_0 \longrightarrow S_1$ excitation ($\lambda \sim 365\text{nm}$) results in effectively zero benzene or carbon monoxide formation, since only the lower vibrational levels of one triplet were populated, and the phosphorescence yields were insensitive to pressure. There was however a significant quantum yield of benzaldehyde consumption and polymer formation could be observed.

The products of irradiation of benzaldehyde in solution have recently been examined by Bradshaw and coworkers.¹⁹⁷ When irradiated in benzene solution for relatively short periods, benzaldehyde yielded almost equal amounts of benzoin, deoxybenzoin and hydrobenzoin; in ethanol solution the main product was hydrobenzoin with only a trace of benzoin present. A more detailed investigation showed that benzoin was the major initial product of the reaction in dilute benzene solution and that it was slowly consumed on prolonged irradiation. The picture is complicated by the observation that irradiation of benzoin in benzene apparently gives first benzaldehyde and then deoxybenzoin and hydrobenzoin at longer irradiation times.¹⁹⁷

Other workers showed by means of chemically induced dynamic nuclear spin polarization (CIDNP) that on irradiation of benzaldehyde in solution a triplet benzaldehyde abstracted a hydrogen atom from a ground state benzaldehyde molecule to give a radical pair which collapsed to form benzoin.¹⁹⁸ The reaction was reversible as shown by the fact that benzoin on irradiation formed the same radical pair. No products were however isolated from these studies.

The photochemistry of benzoin has recently been investigated in more detail. It was found that irradiation of the compound (3.18g) in benzene solution (300 mls) for 6 hrs. resulted in only 28% conversion. V.p.c. showed benzaldehyde and benzoin benzoate were the only volatile products formed. Column chromatography on silica gel afforded unreacted benzoin (2.1g, 66%) and benzoin benzoate

(0.21g, 13%). Irradiation of benzoin in benzene in the presence of dodecanethiol (an efficient scavenger of benzoyl radicals) resulted in an increased yield of benzaldehyde and total suppression of benzoin benzoate formation.¹⁹⁹

Kornis and De Mayo²⁰⁰ attributed the efficient formation of benzaldehyde from benzoin to hydrogen transfer from the hydroxybenzyl radical to the benzoyl radical (Figure 3.7), although benzaldehyde could also be formed via an intramolecular H abstraction such as that postulated by Pitts and coworkers for the

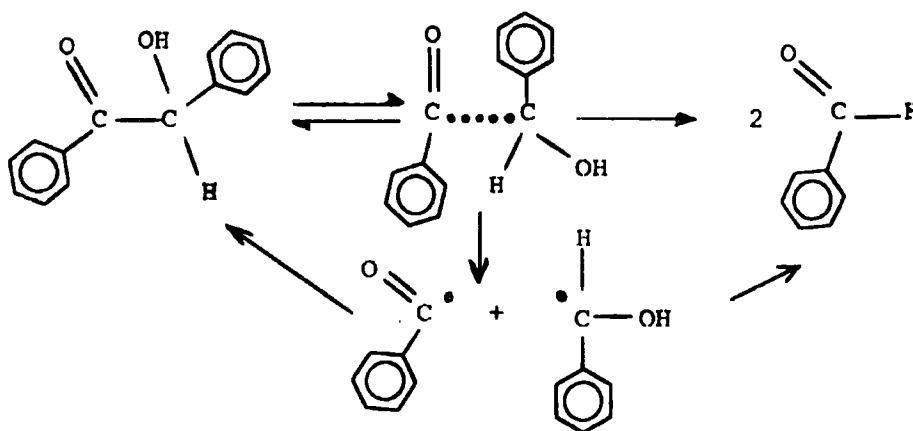


Figure 3.7

formation of acetaldehyde in the vapour phase photolysis of acetoin.²⁰¹ The picture is by no means clear; thus although both the benzoyl and hydroxybenzyl radical have been trapped by irradiating benzoin in the presence of N-oxides and nitroso compounds,¹³⁸ the increase in benzaldehyde quantum yield with added thiol is consistent with H-transfer prior to or at the same time as α -cleavage. It has been shown that benzil is formed by combination of two benzoyl radicals;^{202,203} and it is known that benzil yields benzoin benzoate as the major product of irradiation in cumene solution, that is in the presence of a hydrogen donor.

3.1.e. Original ideas

The photoreductive polymerization of aromatic diketones is well documented (see Chapter 2). However, there have been no reports on the irradiations of

aromatic dialdehydes in the presence of hydrogen donors. It was therefore decided to investigate the behaviour of two of these dialdehydes, namely tere- and iso-phthalaldehyde, on exposure to ultraviolet light both in the solid state and in solution in the presence of hydrogen donors. It was also decided to attempt a closer examination of the 'photopolymer' formed on irradiation of neat benzaldehyde in the liquid phase in the hope of obtaining some information on the structure of this material which has been the subject of several previous investigations.

3.2. The photochemistry of tere- and iso-phthalaldehyde

3.2.a. Results

A summary of experimental procedures and results obtained may be found in Table 3.1.

Irradiations were carried out in sealed tubes under reduced pressure in order to exclude oxygen from the system, since terephthalaldehyde is known to yield terephthalic acid on irradiation in the presence of oxygen.²⁰⁴

Distilled water and perfluoro(methylcyclohexane) were used as the suspending agents for the solid state irradiations since the dialdehydes were not detectably soluble in either of these media at 25^o. In both cases efficient stirring and mixing was provided by means of an external mechanical stirrer.

Whereas irradiations in the solid state afforded quantitative recovery of starting materials, irradiations in the presence of a hydrogen donor afforded initially insoluble products which showed both carbonyl and hydroxyl absorptions in the i.r. region. Irradiations were repeated under the following modifications: (a) the solutions were made as concentrated as possible, (b) H-donor and solvent were very carefully purified before use, (c) solutions were carefully degassed on a grease-free, Hg-free vacuum line and tubes were sealed under lower pressure (ca. 10^{-5} mm Hg), (d) 350nm radiant source was used instead of the HANOVIA 450-W Hg lamp in an attempt to effect greater overlap between

Table 3.1

Expt.	Starting Materials		Medium	Concn. (M)	Lamp Time (Hrs.)	Temp. (°C)	Method ^b	H-donor Solvent Ratio	Products	Comments
	Carbonyl Compound	H Donor								
1			H ₂ O	Suspension	A	45	A		 quantitatively recovered	c
2				Suspension	A	45	A		98% starting materials back	d
3				0.0486	A	45	A	1:3 v/v	Not characterised	e
4				0.0369	A	45	A	1:4 v/v	Not characterised	f
5				0.448	B	45	B	1:4 v/v	Not characterised	g
6				0.351	B	45	B	1:4 v/v	Not characterised	h

Table 3.1 (cont.)

- Footnotes:
- a. LAMP A: HANOVIA 450-W Hg Lamp.
LAMP B: RUL-350 mm Photochemical Reactor.

 - b. METHOD A: Irradiations carried out in pyrex tubes; solutions degassed by several freeze-pump-thaw cycles on conventional vacuum lines and sealed under reduced pressure (residual pressure in tube \sim 0.005 mm Hg).

METHOD B: Irradiations carried out in pyrex tubes; solutions degassed by several freeze-pump-thaw cycles on high vacuum grease-free/mercury free vacuum line and sealed under reduced pressure (residual pressure in tubes 10^{-5} mm Hg).

METHOD C: Irradiation carried out in 1L florentine flask; solution nitrogen streamed for 1 hr. and quickly stoppered.

 - c. Identified by i.r. spectroscopy/recovered material gave one major spot corresponding to terephthalaldehyde on silica t.l.c. examination (CHCl_3 eluent).

 - d. 2% of a yellow material was also obtained (soluble in acetone).
($\bar{\nu}_{\text{max}}$: 3450, 2930, 2860, 2740, 1700, 1605 cm^{-1}).

 - e. Product extracted by freeze-drying (112.5% of the terephthalaldehyde used, reaction with donor and/or solvent (?)). Brittle fibres drawn out of the melt. Displayed considerable thermal stability (no change in i.r. after strong heating on bunsen flame). Soluble in DMF, NMP, Pyridine, ethanediol, ethylmethylketone.

Reprecipitation from DMF (solvent)/ CCl_4 (nonsolvent) afforded 55% of a yellow material.

 - f. Product extracted by freeze-drying (116.4% of the isophthalaldehyde used). Brittle fibres drawn out of the melt. Soluble in DMF, NMP, Pyridine, ethylmethylketone.

Reprecipitation from DMF (solvent)/ CCl_4 (nonsolvent) afforded 61% of a yellow material.

 - g. i.r. spectrum of product obtained superimposable with i.r. of product obtained from expt. 3 - similar physical properties.

 - h. i.r. spectrum of product obtained superimposable with i.r. of product obtained from expt. 4 - similar physical properties.

the lamp emission and the carbonyl $n \rightarrow \pi^*$ absorption and to exclude short wavelength photolysis effects, (e) work-up of the solutions after irradiation was modified, the use of DMF or any other high boiling solvent being avoided. The products however were the same as those obtained in the previous experiments.

Treatment of the products with DMF at room temperature for 7 days resulted in substantial degradation and incorporation of DMF into the products, as shown by both i.r. spectroscopy and mass spectrometry. Heating of the DMF-treated products under high vacuum (100°) for 1 day resulted in partial elimination of the DMF peaks from the i.r. spectrum. The products showed considerable thermal stability (no change in the i.r. spectrum after heating at 250° for 10 mins.). Brittle fibres could be drawn from the melt. Comparison of the i.r. spectra of the products with that of polybenzoin prepared according to established route¹⁷³ revealed considerable difference in the positions and intensities of the main bands. Both photoproducts were found to be soluble in $(\text{CH}_3)_2\text{SO}$ giving bright yellow solutions. However, in contrast with the behaviour of polybenzoin¹⁷³ no autooxidation was detected, the solutions being still clear after 2 months of standing whereas polybenzoin solutions precipitate polybenzil; introduction of oxygen gas in the solutions affected no change; precipitation of the photoproducts after 3 months of standing using water as the non-solvent yielded unchanged photoproducts, as shown by i.r. spectroscopy.

3.2.b. Discussion in the light of recent knowledge

The non-reactivity of the dialdehydes in the solid state should not be considered as a surprising result, since the most likely initial product (a benzoin-type structure) would be expected to cleave rapidly,¹³⁸ yielding the starting material as the main product. The small yield (ca. 2%) of a coloured material obtained from the relatively longer irradiation of isophthalaldehyde in perfluoro(methylcyclohexane) non-solvent could be the result of an out of cage diffusion and dimerization of the radicals resulted from cleavage of the

initially formed benzoin structure; such a process would give pinacol and benzil-type structures which could further react to form the coloured material(s). The behaviour of the dialdehydes on irradiation in the presence of a H-donor is vastly different. Starting materials disappear completely and new products are formed, the physical characteristics and spectral parameters of which were consistent with their being branched low molecular weight pinacols. The branching occurs possibly via the tertiary benzhydryl hydrogen in the polymer backbone which would be expected to be more easily abstractable than the tertiary hydrogen in isopropanol.

3.3. The benzaldehyde photoproduct

3.3.a. Recent preparation and spectral characteristics

Benzaldehyde was recently irradiated in the gas phase resulting in the formation of a polymeric film with interesting properties.¹⁷¹ The reaction vessel consisted of a cylindrical Pyrex (or quartz) sleeve placed concentrically around a medium pressure mercury vapour lamp (Philips philora HPK 125). The experiments were performed at $50.0 \pm 0.2^\circ$. The lamp (protected by a quartz tube) and the reaction cell were immersed in 1M CuSO_4 which served as thermostatic fluid and also, in a layer 0.5 cm thick between the lamp and the cell, as a filter to cut off all light with wavelengths $< 300\text{nm}$. This selection was necessary to minimize benzaldehyde decomposition to benzene and carbon monoxide. In every photolysis, the pressure drop observed corresponded to at least 70% of the benzaldehyde polymerizing. The gas chromatographic analyses of the residual gases showed peaks with the same retention time as benzene and benzaldehyde, the latter being present in trace quantities. Freezing down of the residual gases showed the presence of an important fraction that was non-condensable at -196° assigned by the authors¹⁷¹ as carbon monoxide formed by secondary photolysis of the photopolymer. The product was removed from the cells mechanically or by dissolution in various solvents. It was found to dissolve

very slowly in tetrahydrofuran, dioxane and methanol at room temperature, and quickly in benzene at 20° and methanol at 60°. The ultraviolet absorption spectrum of the polymer in methanol solution showed a maximum at 234nm, a shoulder at 248nm (corresponding to the absorption maximum of benzoin²⁰⁵) and a structureless tail out to at least 450nm. The i.r. spectrum of the polymer was also recorded (KBr disc) and was shown to be different from that of benzoin. Two absorption bands at 1685 and 1723 cm⁻¹ were indicative of two different carbonyl environments. Luminescence excitation spectra of the product (benzene solution, room temperature) taken with 366, 406, and 436nm excitation were consistent with the presence of two active chromophores in the structure. The polymer film on the cell wall was found to sensitize cis \rightleftharpoons trans isomerization of 1,3-pentadienes and to be active even after long periods of service. Its activity decreased by a factor of 15 after 3 hrs. of irradiation in the presence of 50.7 torr of oxygen; this treatment also caused the disappearance of the yellowish colouration of the polymer.¹⁷¹ The structure of the polymer was not established; the aim of this work was to fill that gap.

3.3.b. Experimental

3.3.b.1. Purification of benzaldehyde

300 mls. portions of technical grade benzaldehyde (BDH Chemicals Ltd.) were washed with five 200 mls. portions of 1M K₂CO₃ (aqueous solution). The material thus obtained was left to stand over 100g anhydrous MgSO₄ for 5 hrs. It was then transferred through a sinter into a 500 mls 3-necked flask (operation carried out under a nitrogen blanket). This product was fractionally distilled (vacuum jacketed column, 3' x 1", packed with glass helices). The apparatus used in the fractional distillation was dried in the oven before assembly and purged with dry nitrogen for several hours before the fractionation was started; a nitrogen atmosphere was maintained throughout by means of a nitrogen line. Equilibration of the column took about 24 hrs. (pot temp. 178°, column temp.

210°, head temp. 170° - 178°); head temperature was finally equilibrated at 178°. Take off rate was kept at approximately 1 : 120; the first 30 and last 50 mls were discarded. Benzaldehyde thus purified was stored under dry nitrogen. No signs of benzoic acid were noticed at the neck of the flask. Elemental analysis figures, mass spectrum and i.r. spectrum (recorded as a liquid film) were indicative of pure benzaldehyde. A single spot was obtained on examination by t.l.c. on silica (benzene, chloroform, ethylacetate, acetone/water, carbon tetrachloride, propanol); analytical g.l.c. (Col. A, 150°, Col. O, 110°) showed one peak only. The ultraviolet spectrum showed the following absorptions: 370 (2), 353 (8.4), 338.7 (10.4), 327.5 (10.4), 317 (9.4), 306 (7.3), 288 (360), 285 (318.4), 278.5 (412), 248 (2906), 241 (3618) nm (ϵ) (cyclohexane).

3.3.b.11. Irradiations

Benzaldehyde was transferred into dry cylindrical Pyrex vessels under nitrogen, degassed by several freeze-pump-thaw cycles on a conventional vacuum line, and sealed under reduced pressure (10^{-3} mm Hg). In some irradiations a Hg-free, grease-free vacuum line was used and the tubes were sealed under lower pressure (ca. 10^{-6} mm Hg). All irradiations were carried out at ca. 40° using 350nm lamps. The reaction was found to be very slow. A yellow colour usually developed after 50 hrs. of irradiation and the initially water white mobile liquid turned into a brown viscous mass after 200 hrs. of irradiation.

Benzaldehyde was initially irradiated for periods of 250 → 360 hrs. In a later experiment four portions of the pure material were irradiated for 100, 350, 660 and 1110 hrs. Contrary to previous reports¹²⁸ no crystalline materials were observed on the walls of the tube. The viscous mass formed appeared homogeneous and no signs of water or other immiscible liquids were detected which casts doubts on the validity of earlier arguments.¹⁶⁹

The tubes were frozen in liquid air before the seal was broken and the open end was immediately connected to a concentrated sulphuric acid bubbler. No pressure was noticed on opening the tubes, even after prolonged irradiations,

indicating the absence of non-condensable gases.

3.3.b.11. Purification of product

The crude products appeared as very viscous masses containing substantial amounts of unreacted benzaldehyde. They were generally purified by repeated precipitations from benzene/60° - 80° petroleum ether. The resultant yellow powders were dissolved in diethylether, washed with dilute aqueous carbonate, then with water and precipitated again using petroleum ether as the non-solvent. Some samples were also precipitated from ethanol/water. In contrast with previous reports^{127,128,169} it was not possible to obtain white powders even after a great number of precipitations. Concentration of mother liquors did not afford any crystalline compounds. In some early experiments, steam distillation was used as a purification technique; benzaldehyde was the only detectable steam-volatile material (t.l.c. on silica (benzene, chloroform), Col. A, 150°, 100°, 60°).

The products were found to be soluble in carbon tetrachloride, chloroform, methylenechloride, toluene, acetone (in cold) and in hot alcoholic solvents; they were insoluble in aliphatic hydrocarbons, aqueous potassium carbonate or methanol/water/potassium carbonate mixtures. On slow cooling of hot concentrated or dilute alcoholic solutions, yellow amorphous powders were obtained. Fairly long (sometimes over 100 cm.) fibres were drawn out of the melt; they were however very brittle.

T.l.c. analysis of the precipitated products (benzene/petroleum ether, ethanol/water) showed the presence of one component only, sometimes with a small faint tail which is however not uncommon for polymeric materials (benzene, chloroform, carbon tetrachloride/chloroform 50:50, ethanol/chloroform 50:50, chloroform/methanol/carbon tetrachloride, acetone/methanol/ethanol, ethanol/acetone 50:50, benzene/chloroform, ethanol/acetone/water).

Decolourization of the amorphous material was attempted using activated animal charcoal in hot methanol solution. Repeated treatments gave an off white

material (60%) which could not be further decolourized by this method; it had the same spectral characteristics as the yellowish powder obtained from the precipitations.

All products melted between 130° - 140° and elemental analysis figures correponded to those calculated for benzaldehyde. Photopolymer yields (after precipitation and drying) were found to vary with irradiation time as follows: 32% (100 hrs.), 48% (350 hrs.), 59% (660 hrs.), 68% (1110 hrs.).

3.3.b.iv. Attempted characterization of the 'photopolymer' of benzaldehyde

The solid state i.r. spectra (KBr discs) and the ultraviolet spectra (methanol) of the photoproducts obtained from irradiations varying in duration from 100 to 1100 hrs. were identical and the same as those reported previously.¹⁷¹ The ^1H n.m.r. spectrum (CDCl_3 , int. TMS ref.) displayed only one broad peak (δ 7.3). The ^{13}C n.m.r. spectrum showed a peak at δ 198.9 (possibly carbonyl carbon), a singlet at δ 128.3 (aromatic ring carbons) and a singlet at δ 42.38 which is difficult to assign; its value is however close to the one recorded for the sp^3 hybridised carbon in 1,4-dibenzylbenzene (see Chapter 2). The mass spectrum of the material extended to m/e 930 (d.p. of ca. 9) with prominent peaks at irregular intervals, namely at 810, 722, 706, 690, 616, 600, 583, 569, 553, 511, 493, 477, 465, 405, 389, 375, 361, 351, 339, 315, 301, 283, 271, 252, 239, 221, 210, 208, 180, 168, 152, 122, 105, 90, 77 (spectrum recorded at 70 eV). Determinations of molecular weights in chloroform solution (isopiestic method) gave d.p.'s in the range 9 - 11 for purified samples, independent of irradiation time.

The solution phase i.r. spectrum of the photoproduct (carbon tetrachloride, saturated solution) was recorded in the region 4000 to 2500 cm.^{-1} (Spectrum 39, Appendix B). The spectrum showed some alteration on successive dilution and indicated the presence of free hydroxyl (3620 cm.^{-1} , sharp), internally hydrogen bonded hydroxyl ($3200 - 3500\text{ cm.}^{-1}$, broad and structureless) and

aromatic carbon - hydrogen stretching ($3030 - 3090 \text{ cm.}^{-1}$). The shoulder visible at higher concentrations (D, Spectrum 39, Appendix B) might arise from intermolecular hydrogen bonding and the band in the region $2800 - 3000 \text{ cm.}^{-1}$ displays structure which also alters somewhat on dilution; this band would be expected to arise from aliphatic carbon - hydrogen stretching modes, however the band shape alteration on dilution is puzzling. The solid state i.r. spectrum of the benzaldehyde 'photopolymer' (No. 31, Appendix B) displays two absorptions in the carbonyl region, 1685 and 1723 cm.^{-1} ; the carbonyl frequencies observed for benzoin benzoate, one of the reported benzaldehyde photoproducts, were 1712 cm.^{-1} (ester carbonyl) and 1698 cm.^{-1} (keto group); it seems unlikely therefore that the benzoin benzoate unit is a part of the photopolymer structure, although it must be admitted that this is not a particularly rigorous argument.

Irradiation of the material (3.0g) in benzene (20 mls) (nitrogen streamed solution, 24 hrs., 300nm) effected no change in either the molecular weight or the spectral characteristics.

These usual physical approaches to structure elucidation did not yield a convincing structural hypothesis although it is clear that the product contains hydroxyl, carbonyl and phenyl groups. In view of this fact it was decided to attempt some investigations of chemical reactions on the benzaldehyde 'photopolymer' in the hope that this 'classical' approach might yield some structural evidence. An account of these preliminary studies is given below.

Attempted photoreduction of the 'photopolymer' (3.0g, benzene/isopropanol 2:3 (50 mls), nitrogen streamed solution, 24 hrs., 300nm) yielded unchanged starting material as evidenced by i.r. and n.m.r. spectroscopy.

Attempts to obtain crystalline derivatives of the 'photopolymer' via the carbonyl groups by reacting small portions of it with 2,4-dinitrophenylhydrazine in ethanol or hydroxylamine hydrochloride in the presence of either pyridine or sodium acetate gave inconclusive results. The latter experiment

afforded recovery of starting material whereas the former resulted in the formation of a material which was unstable and could not be purified.

Treatment of the photoproduct with bromine in carbon tetrachloride solution at room temperature effected no change in the structure of the material as evidenced by i.r. spectroscopy. However on heating the solution at 50° a slow absorption of bromine was observed with simultaneous evolution of an acid gas, possibly resulting from substitution or oxidation reactions. Refluxing the photoproduct (2.0g) with bromine (1.0g) in acetic acid (20 mls) for 2 hrs. did not effect incorporation of bromine into the original structure as shown by Lassaigne's test. The operation resulted in the appearance of a new peak in the i.r. spectrum at 1770 cm.⁻¹ but no change in the shape or intensity of the hydroxyl band was observed; these later results favour an oxidation process for the reactions with bromine.

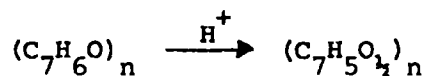
Refluxing the 'photopolymer' (5.0g) with acetylchloride (100 mls) for 3 hrs. under a nitrogen blanket afforded a material whose i.r. spectrum showed a considerably diminished hydroxyl band intensity and a new absorption at 1740 cm.⁻¹, presumably due to acetate group(s). No substantial increase in the intensity of the aliphatic carbon - hydrogen absorption was however apparent.

Refluxing the 'photopolymer' (5.0g) with potassium permanganate (10.0g) in neutral acetone (750 mls) for 3 hrs. yielded a product whose i.r. spectrum showed no major change from that of the original material.

Pyrolytic decomposition in an inert atmosphere yielded primarily benzaldehyde (over 90% yield) along with several minor products and an intractable tar. The very high yield of benzaldehyde from this pyrolysis suggests that the unit is not substantially changed on incorporation into the polymer. Attempted examination of the non-volatile residues by t.l.c. on silica (benzene, ethanol, chloroform, acetone, carbon tetrachloride) did not yield definitive results since there were many overlapping components. Contrary to previous reports¹¹⁹ it was not possible to isolate hydrobenzoin from this experiment.

Reduction with an excess of sodium borohydride in 1,4-dioxane solution (40 hrs. at reflux) resulted in almost complete elimination of the carbonyl function(s) and increase in the intensity of the hydroxyl bands in the i.r. spectrum (No. 32, Appendix B). Mass spectral analysis indicated that the molecular weight may have been significantly reduced. On the other hand, reduction with excess Vitride in benzene solution (nitrogen blanket, 18 hrs. at reflux) afforded an almost quantitative recovery of a material whose i.r. spectrum (No. 33, Appendix B) was significantly different from the one obtained from the reduction with sodium borohydride and in this case the carbonyl absorptions were totally eliminated. Such a difference in behaviour might be rationalized if the 'photopolymer' contained ester groups since Vitride reduces them whereas borohydride does not.

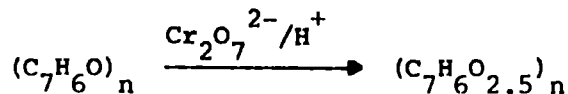
Prolonged refluxing of the 'photopolymer' with aqueous sulphuric acid (6N) resulted in a marginal change in the intensity and shape of the hydroxyl bands and a significant change in the number and intensities of the carbonyl bands in the i.r. spectrum (No. 38, Appendix B). Elemental analysis of the product from this reaction (Found: C, 84.94; H, 5.07%; Calculated for $(C_7H_6O)_n$: C, 79.22; H, 5.70%) was consistent with the overall change being represented as:-



That is an apparent loss of one molecule of water for every two benzaldehyde residues in the polymer. The product of this reaction although a solid had an extremely nauseous smell which precluded further examination.

Treatment of the 'photopolymer' (3.0g in benzene (80 mls)) with potassium dichromate (20.0g in water (10 mls)) and concentrated sulphuric acid (15 mls) for 40 hrs. at reflux, resulted in a considerable decrease in the intensity of the bands in the i.r. spectrum associated with hydroxyl and an increase in the intensity and number of bands in the carbonyl region. There was also a significant alteration in the position and intensity of the bands in the aliphatic carbon - hydrogen stretching region. Elemental analysis of the

product (Found: C, 64.98; H, 4.56%) was consistent with the overall change being represented as:-



That is, an apparent incorporation of three oxygen atoms for each pair of benzaldehyde residues in the 'photopolymer'. This experiment, however, was not particularly reproducible and attempts to prepare larger quantities of the product resulted in the isolation of a greenish powder, soluble in organic solvents (ethanol, benzene, chloroform) which was found to contain chromium (6.27%). Treatment of this material with diethylether afforded an ether-soluble material which contained 1.28% chromium. Treatment of both materials with dilute sulphuric acid in ether solution did not effect removal of chromium; these materials were probably chromium complexes of the 'photopolymer'.

The results of the reactions of the 'photopolymer' with acid and oxidizing agents under acid conditions are not amenable to a simple explanation. The hydroxyl diminishing/carbonyl increasing effect of the acid treatment is reminiscent of a pinacol - pinacolone type of reaction and the loss of a molecule of water is, of course, also consistent with such a sequence. An obvious candidate for the oxidation reaction which results in an increase in the oxygen content but no change in the carbon/hydrogen ratio would be oxidation of aldehyde to carboxylic acid units; unfortunately the infrared spectrum (No. 35, Appendix B) does not support such a rationalization and in fact the oxidation process is accompanied by a marked decrease in the hydroxyl intensity.

It has not proved possible, at the time of writing to rationalize the results described above; the possible nature of the benzaldehyde 'photo-product' and suggestions for elucidation of its structure are discussed below.

3.3.c. Conclusions and suggestions for further work

The present experimental work adds to the facts known about the benzaldehyde 'photopolymer' without solving the problem of its structure. It is perhaps

surprising that in the light of available knowledge and techniques the problem remains unsolved despite the intermittent attentions of different workers over a period of seventy years. In attempting to set up hypotheses for test it becomes clear that an enormous variety of structures could reasonably be derived by 'paper chemistry' for the product of prolonged irradiation of benzaldehyde; this point is illustrated below.

In the photochemistry of aromatic carbonyl compounds, discussed in Chapter 2, a prevalent theme was the combination of radical pairs produced from an initial photochemical process. If we consider the primary pair of radicals known to be formed on irradiation of benzaldehyde we see that a very large number of possibilities can be generated from their combination; these are illustrated in Figure 3.8. The top part of the Figure summarizes some of the established processes, and it may be that the 'photopolymer' arises from further reactions of one of these materials. If, on the other hand, the radical - radical recombination occurred at the para-positions of one or other of the phenyl rings the structures I and II drawn in the lower half of the Figure would be the initial products. Both these species could lead to a variety of further products. However these are by no means the only plausible initial products of radical - radical combination, which could equally reasonably occur at ortho positions of phenyl rings (generating conjugated dienes) and between identical radicals. Clearly the structures which could be drawn are almost endless, and this approach to a structural hypothesis is unlikely to be very helpful at this stage.

It is perhaps worth discussing possible ways around the present difficulties. The techniques available in the present work suggest that the product is a homopolymer of benzaldehyde, and that it has a d.p. in the range 9 - 11, that it is a single component (t.l.c. on silica) and that the basic benzaldehyde units can be regenerated on pyrolysis although there are several different structural units in the polymer. Probably the first point to establish in any continuation of this investigation would be the homogeneity of the material; this might be

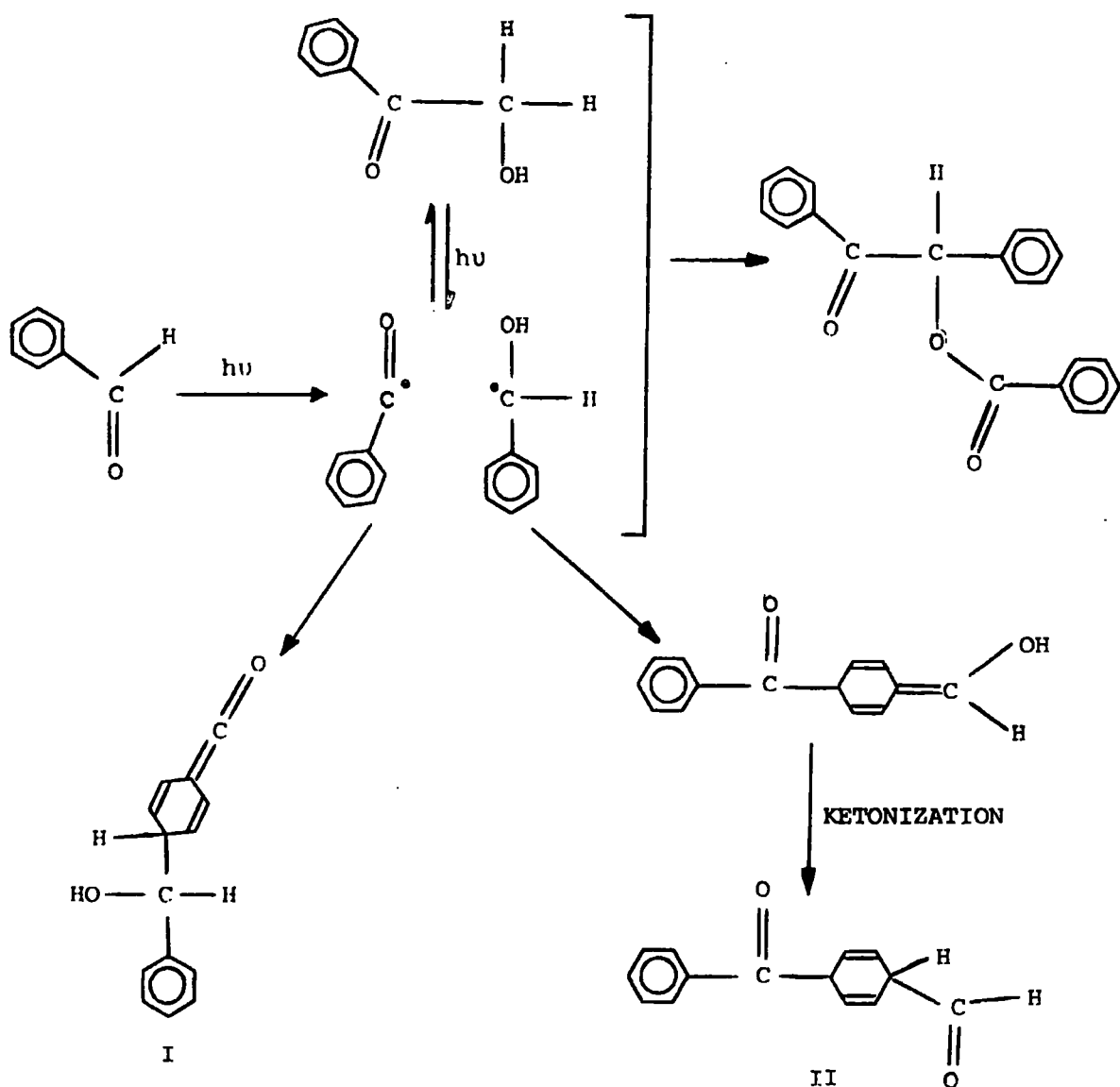


Figure 3.8. Illustration of some possible modes of combination of the primary radical pair formed on irradiation of benzaldehyde.

tested using high pressure liquid chromatography. Assuming the product is shown to be homogeneous, the lines of structural investigation reported here are probably capable of further exploitation. Two examples will serve to illustrate the possibilities. The product of reduction with Vitride will be at least a two component mixture if the 'photopolymer' backbone contains ester links;

the components might be separable by high pressure liquid chromatography and amenable to characterization. The pyrolytic fragmentation of the products obtained by treating the 'photopolymer' with sulphuric acid and oxidizing agents may yield products other than benzaldehyde which might provide clues to the overall structure.

The above suggestions are illustrative of the chemical approach, and it is still possible that spectroscopic techniques might yield more detailed information. Thus, improved ^{13}C n.m.r. facilities may well be useful; even the ^1H n.m.r. spectra might prove much more informative if a sample of benzaldehyde 'photopolymer' derived from $\text{C}_6\text{D}_5\text{CHO}$ were to be prepared. Finally, if a systematic study of possible model compounds were carried out the recent resolution improvements in the ESCA technique might allow useful structural information to be deduced.

CHAPTER 4

Studies on the cycloaddition of perfluoroglutarylfluoride to some
perfluoroolefins

4.1. The Paternò-Büchi reaction

4.1.a. Introduction

The photocycloaddition of carbonyl compounds to olefins leading to the formation of oxetanes (Figure 4.1) was first reported by Paternò and Chieffi at the beginning of the century.¹¹⁹ Büchi reinvestigated the reaction in

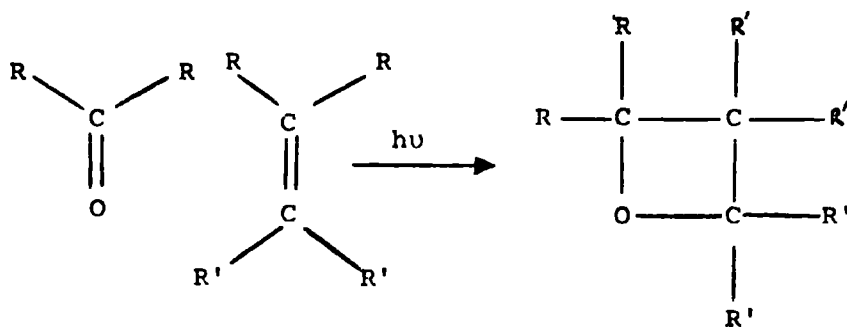


Figure 4.1

1954²⁰⁶ and as a result of his work the cyclic four member ether structure for the reaction product was verified. However, it was not until fourteen years later that the first attempt to demonstrate the scope and usefulness of the reaction was made.²⁹ The reaction is frequently referred to as the Paternò-Büchi reaction and it is recognised as the most useful method for the synthesis of cyclic four membered ether compounds (oxetanes). Both starting materials (carbonyl compounds and olefins) are readily available either commercially or through well established laboratory syntheses. Yields vary from very low to nearly quantitative, depending on a variety of factors, the number and nature of side reactions being one of them. Comprehensive reviews of the Paternò-Büchi reaction are available.^{29,207}

In the original experiment, Paternò and Chieffi reported that insolation of benzophenone in a petroleum mixture rich in 2-methyl-2-butene resulted in the formation of an oxetane in good yield (Figure 4.2). Büchi's assignment of oxetane structures to the products obtained by irradiation of acetophenone, benzaldehyde and butanal in the presence of pure 2-methyl-2-butene was based on the identification of carbonyl compounds formed from acid catalysed cleavage

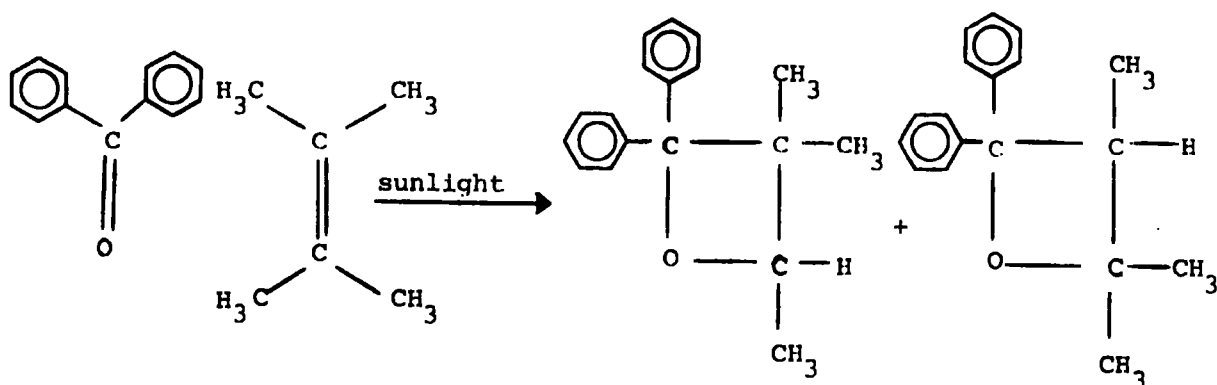


Figure 4.2

of these products.²⁰⁶ A comprehensive table of oxetanes prepared by the Paternò-Büchi reaction has been produced by Arnold.²⁹ Carbonyl compounds successfully undergoing photocycloaddition include aliphatic and aromatic aldehydes and ketones, fluorocompounds, p-quinones as well as compounds containing functional groups in addition to the carbonyl group. Olefins used embrace linear and cyclic systems, including fluoroolefins. In addition to olefins other unsaturated systems have been employed including allenes, acetylenes and ketenimines. The cycloaddition may be intramolecular or intermolecular.

4.1.b. Mechanism

Photoreduction and cycloaddition reactions are characteristic of the carbonyl $n \rightarrow \pi^*$ state²⁹ and carbonyl compounds undergoing photocycloaddition generally undergo photoreduction in isopropanol.²⁰⁸ The important steps in the reaction for electron rich olefins may frequently be represented by the scheme shown in Figure 4.3. Reaction may be brought about by irradiation in regions where only the carbonyl compounds absorb; thus initial excitation of the carbonyl chromophore can be demonstrated. Deactivation of the excited state without oxetane formation may occur by a variety of competing processes, the n, π^* triplet existing in fluid solution for approximately 10^{-5} sec.⁸⁵ The rate of cycloaddition must be rapid enough to occur before the excited carbonyl compound returns to the ground state by, for example, radiative deactivation. Singlet and triplet excited states may be quenched by interaction with some

- i) Excitation $\text{RCOR} \xrightarrow{h\nu} \text{RCOR}^* \text{ (singlet)}$
- ii) Intersystem Crossing $\text{RCOR}^* \text{ (singlet)} \longrightarrow \text{RCOR}^* \text{ (triplet)}$
- iii) Deactivation RCOR^*

radiative or non-radiative	\longrightarrow	RCOR (ground state)
with or without quenchers		
with molecular rearrangement		
- iv) Reaction

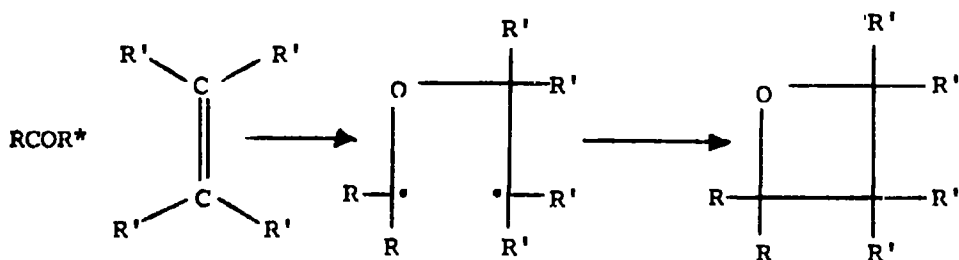


Figure 4.3: Reaction scheme for oxetane formation

other molecule such as an unsaturated system.²⁹ The actual photocycloaddition generally involves attack on the ground state olefin by the n, π^* triplet excited carbonyl compound.²⁹ The reaction sequence in Figure 4.3 involves addition of the lone electron of the oxygen atom to an unsaturated system giving a 1,4-biradical intermediate which subsequently ring closes to form the oxetane. With unsymmetrical unsaturated olefins two isomers may be formed; the stereochemistry of the major adduct can be predicted from a consideration of the relative stability of the possible biradical intermediates. If the n, π^* triplet is involved, spin inversion must occur before bonding.²⁰⁹

There is good evidence for the formation of the biradical intermediate during the reaction,²⁹ and a significant number of cycloaddition products can be rationalized by the biradical mechanism. There are however alternative mechanisms proposed which include charge-transfer complex formation,²¹⁰ and exciplex formation.^{211,212} For instance intramolecular cycloaddition in 5-hept-2-one is thought to proceed via singlet exciplex formation.²¹³ It has also been suggested that cycloaddition of benzophenone to 2,3-dimethyl-1,3-butadiene proceeds by addition of diene triplet to ground state benzophenone.²¹⁴

Other reports of oxetane formation from excited olefins and ground state carbonyl compounds have appeared.^{215,216,217}

4.1.c. Limitations

A major restriction on successful high yield photocycloaddition reactions is the nature and extent of competing processes, mainly hydrogen abstraction by the excited carbonyl from the olefin, solvent, or even the oxetane itself; the hydrogen α to ether oxygen being particularly susceptible to abstraction. The case may be exemplified by the reaction of photoexcited benzaldehyde with cyclohexene (Figure 4.4), where three products in addition to the oxetane are isolated.

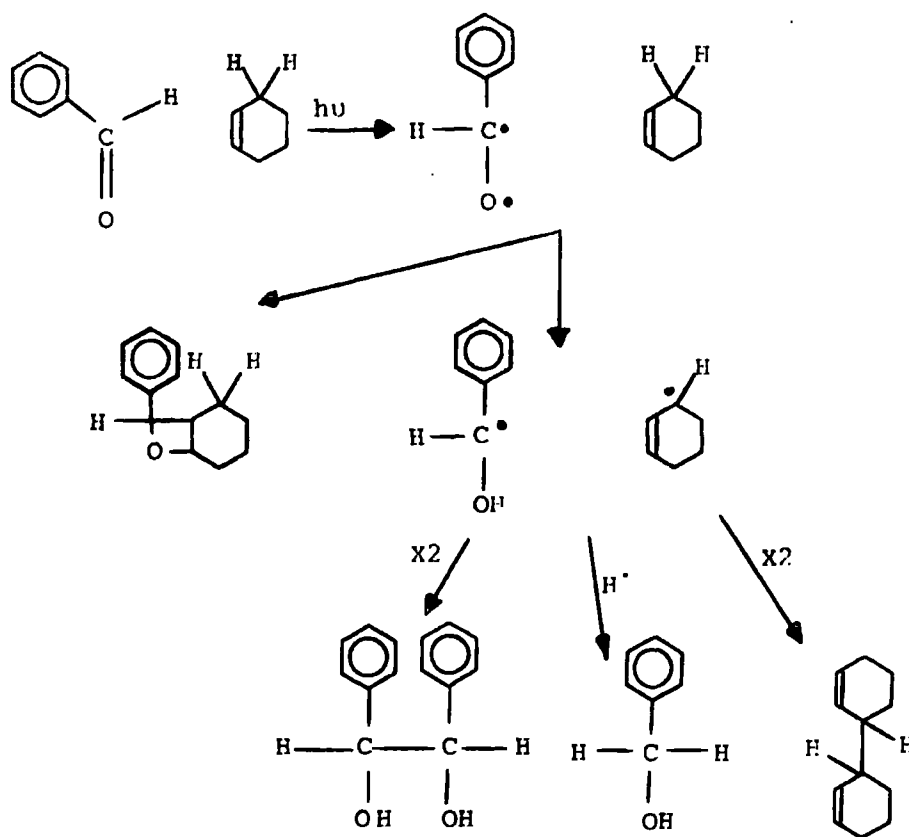


Figure 4.4

Cyclobutane formation may be an alternative reaction to oxetane formation, as with 1,4-quinones such as chloranil (Figure 4.5).²¹⁸ Norrish type I and

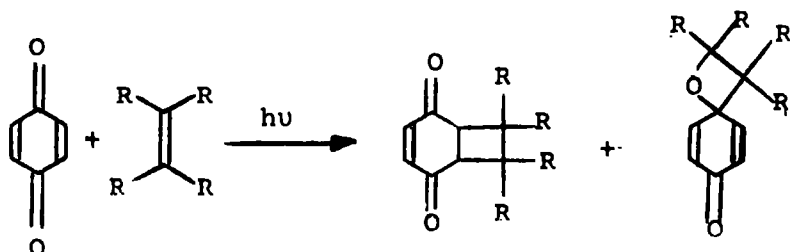


Figure 4.5

type II processes may compete with oxetane formation. Norrish type I rupture of acyl-halide bonds of perfluoroacylchlorides and bromides competes with oxetane formation from these carbonyl compounds.²¹⁹

Products must be stable to the irradiation conditions used. Oxetanes are transparent in the long wavelength region but may ring open on irradiation at short wavelengths.²²⁰

Photochemically active chromophores present in addition to the carbonyl group of the carbonyl compound may lead to complications, for example in further reaction beyond oxetane formation as with irradiation of fluorenone and tetramethylallene (Figure 4.6).^{29,221}

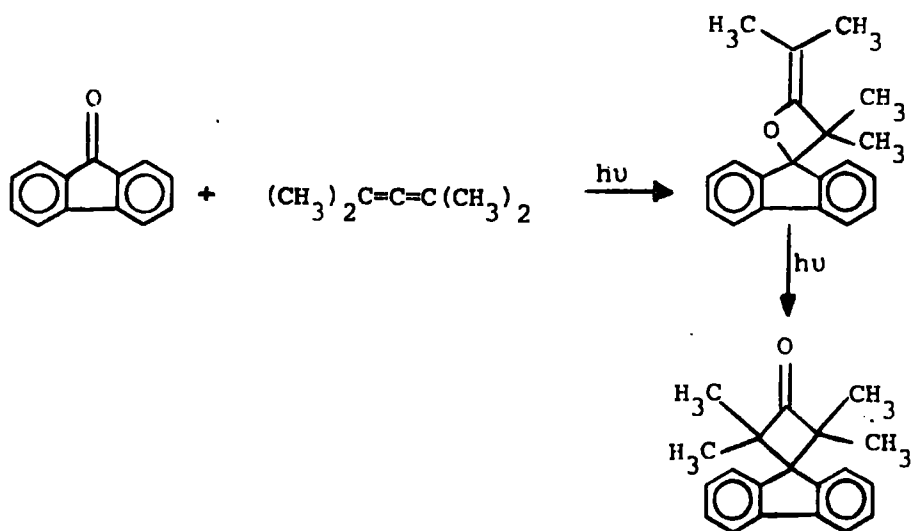


Figure 4.6

Oxetane products though detectable and characterizable by infrared and n.m.r. spectroscopy may be too unstable for purification, an example being the oxetane from 4,4'-dimethoxybenzophenone and isobutylene which fragments into formaldehyde and diarylethylene (Figure 4.7).^{29,208}

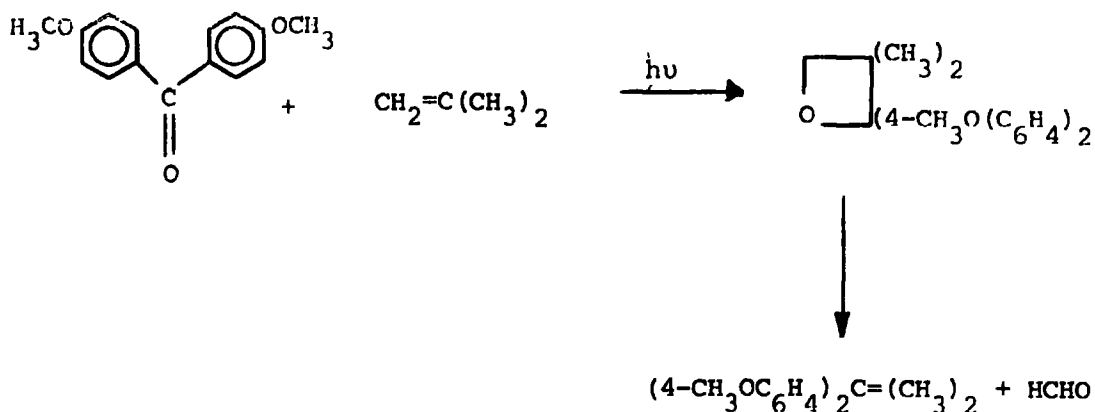


Figure 4.7

4.2. Application of the Paternò-Büchi reaction to polymer synthesis

The photochemical reaction of a carbonyl group with an olefin yielding an oxetane has been used for crosslinking, chain extension and structural modification of polymers.¹⁶ In principle, there are two possible ways in which the reaction can be used in the synthesis of linear polymers with oxetane units in the polymer chain; they are represented by equations (i) and (ii) in Figure 4.8. The lower route was examined by Andrews and Feast;^{26,27}

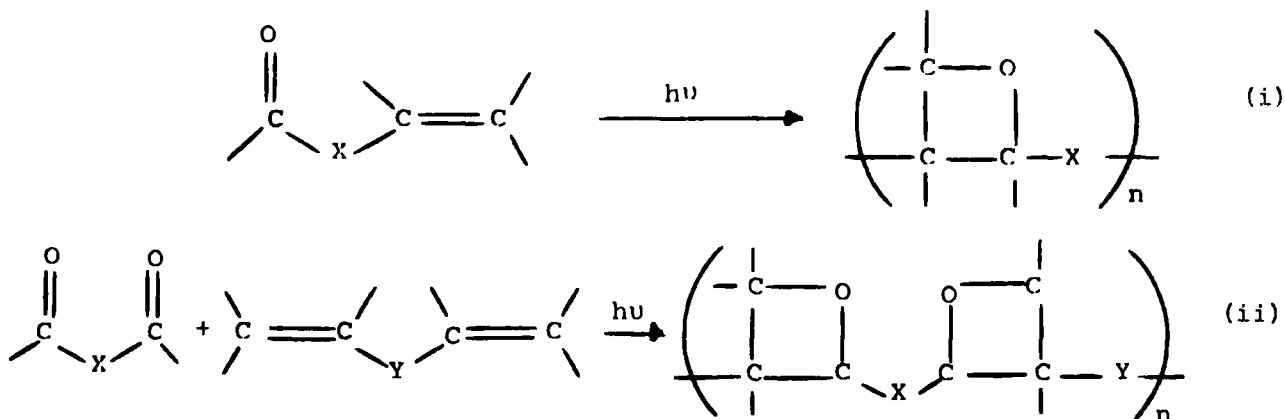


Figure 4.8

a variety of aromatic bisketones and two different diolefinic systems, tetramethylallene and furan were used as monomers. Their choice was based on several criteria: the model reactions with monofunctional reagents were thoroughly studied and understood;²⁹ monomers and polymers were soluble in photostable solvents; reactions proceeded in high yield and conversion without chain terminating side reactions and both reactants and products were stable to radiation in the energy range required for photopolymerization. These restrictions eliminated a large proportion of the documented Paternò-Büchi reactions as candidates for photopolymerization studies.

In the case of the bisketone-tetramethylallene photopolymerizations, the investigations carried out established that under appropriate conditions copolymers in which ca. 90% of the polymer chain links are oxetanes can be prepared by irradiation of equimolar solutions of aromatic diketones and tetramethylallene in benzene.²⁶ In this respect, the behaviour of aromatic bisketones seem to be in line with the behaviour of their monofunctional analogue, benzophenone, which affords ca. 90% oxetanes upon irradiation in tetramethylallene, and 10% hydroxyl-containing products, arising presumably from radicals formed in an initial hydrogen abstraction reaction by the photoexcited carbonyl²⁹ (see Chapter 1, Section 1.3).

The reaction between benzophenone and furan has been the subject of numerous investigations.²²²⁻²²⁹ In 1963 it was reported that irradiation of benzophenone in excess of furan gives the 1:1 adduct, 6,6-diphenyl-2,7-dioxabicyclo[3.2.0]hept-3-ene in near quantitative yield.^{222,223,224} Subsequently the formation of 2:1 adducts from the photocycloaddition of two molecules of benzophenone to one of furan was reported,²²⁵ and adducts isolated were assigned the structures shown in the upper part of Figure 4.9. By analogy to the photochemical behaviour of the bisketone-tetramethylallene system, irradiation of equimolar amounts of bisketones and furan in benzene were expected to yield polymers of the structure shown in the lower part of Figure 4.9. Several

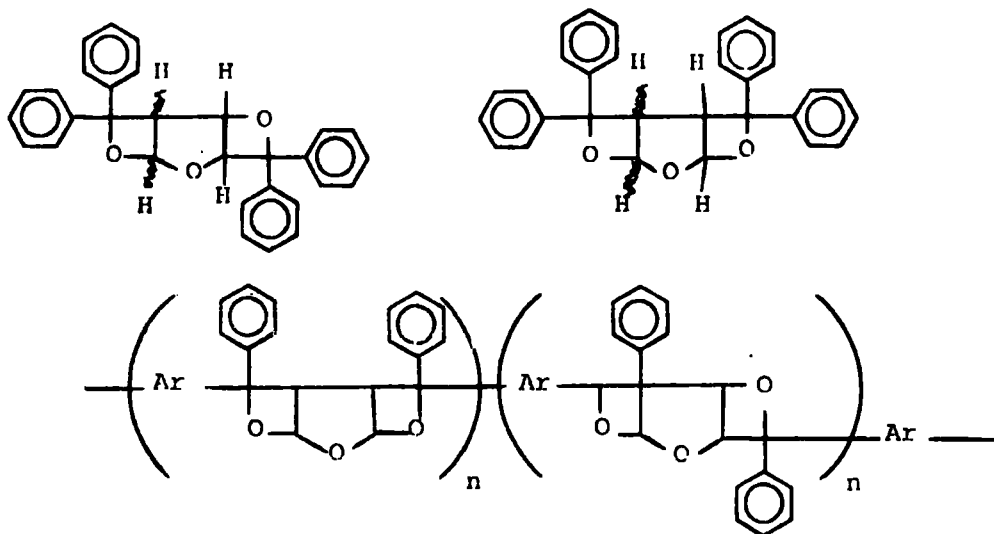


Figure 4.9

attempts to effect the expected reaction were largely unsuccessful, yielding only low molecular weight materials suggesting that the problems inherent in the quantitative manipulation of furan (b.p. 32°C) were preventing the preparation of precisely equimolar solutions. Finally this difficulty was overcome by preparing 2:1 adducts between the diketones and furan according to the equation in Figure 4.10. These adducts being solids could be quantitatively

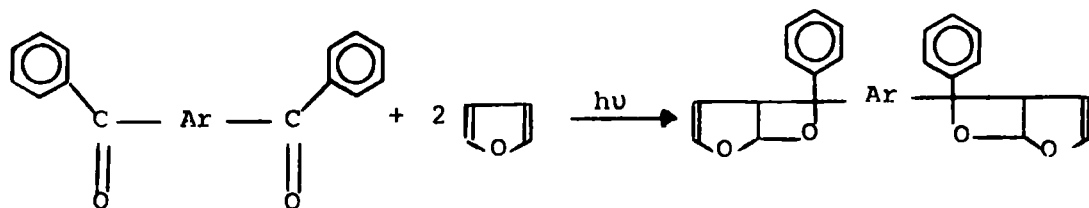


Figure 4.10

manipulated without difficulty, and subsequent irradiation of equimolar solutions of 2:1 furan-diketone adducts and diketones in benzene gave rise to linear polymers of d.p.'s upto 23.²⁷ Spectroscopic examinations of these materials revealed both oxetane and hydroxyl bands in the infrared region.

Previous studies of the reaction between benzophenone and furan had not revealed any tendency for hydrogen abstraction from furan by benzophenone triplets;²²²⁻²²⁹ indeed in the reactions of benzophenone with methylfurans, where abstraction from the allylic C - H bonds might be expected to be favourable, the authors specifically state that oxetanes were the only products.²²⁸ However, since the experimental details of the polymerizations and those of the model reactions were different in several respects (due to low monomer solubility and relatively slow oxetane formation), possible sources of the hydroxyl hydrogen could be postulated. For instance slow photoreaction of benzophenone with benzene is known to yield benzopinacol and diphenyl;^{77,83-87} also, all polymers contain a C - H bond α to two ether oxygens and such hydrogens are known to be particularly susceptible to abstraction. Such abstractions could lead to crosslinking and precipitation.²³²

It is thus apparent that application of the Paternò-Büchi reaction to polymer synthesis in the systems investigated was only partly successful, mainly due to competing processes (especially hydrogen abstraction and crosslinking), relatively low monomer solubility and prolonged irradiation times.

4.3. Applications of the Paternò-Büchi reaction to polyfluorinated and perfluoro systems

Cyclic ethers as a class have been known for a long time and have been well recognized as useful organic intermediates and as solvents and plasticizers. Generally such ethers have been limited in their usefulness because of relatively low stability. In 1961 however, a new class of four membered cyclic ethers, fluorosubstituted oxetanes, appeared in the literature and their preparation from fluoroolefins and fluoroaldehydes via the Paternò-Büchi reaction was described. More specifically this new class of polyfluorocyclic ethers carried one hydrogen atom on the ring carbon adjacent to ether oxygen; their outstanding chemical and physical stability was emphasized by the author.²³³

The new 2-hydropolyfluorooxetanes reported ranged from clear, colourless liquids to low melting solids, depending generally on the total number of carbons in the molecule. Those containing less than about eighteen carbons were clear, colourless liquids boiling from 100° - 300°C. They exhibited high hydrolytic stability, both under aqueous acid and aqueous base conditions. They were soluble in alkanols, ethers and various perfluorocarbon solvents but insoluble in water and solutions containing high percentage of water. They were non-inflammable and exhibited outstanding resistance against thermal and oxidative degradation. These properties made the new compounds useful as 'stable liquid' materials, for example, as transformer fluids, fluids for high temperature power transmissions, or hydraulic systems, or liquid coupled mechanical drives. Vigorous chlorination could substitute the 2-hydrogen with chlorine, and the 2-chlorine could be readily converted to other interesting chemical intermediates by conventional methods of replacement and modification of the relatively reactive ring chlorine substituent using standard methods employed in synthetic organic chemistry.

These polyfluoro-2-hydrooxetanes were generally prepared by direct irradiation of the two reactants in cylindrical quartz reactors approximately four diameters long, maintained at atmospheric pressure and under reflux from a solid carbon dioxide/acetone cooled condenser. No solvents for the two reactants were used. Ultraviolet light from a low-pressure, 10 watt, quartz, mercury resonance lamp fitted in a spiral around the reactor was employed as the source of energy. Irradiation times ranged from three days (chlorotrifluoroethylene/ ω -hydroperfluorovaleraldehyde) to twelve days (hexafluoropropene-1/perfluoro-n-butyraldehyde). Yields ranged from 27% to 66% of theory. No mention of by-products or side reactions was made by the author.²³³

Oxetanes successfully synthesized by this method are illustrated in Figure 4.11 and include 3,4,4-trifluoro-3-trifluoromethyl-2-perfluoro-n-propyloxetane (I), 3,4,4-trifluoro-2,3-bis(trifluoromethyl)oxetane (II),

2-(4H-octafluoro-n-butyl)-3,4,4-trifluoro-3-trifluoromethyloxetane (III).

Vapour phase chromatography and n.m.r. studies revealed the presence of two

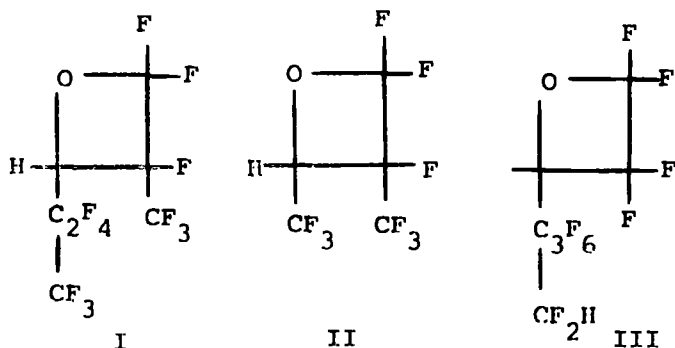


Figure 4.11

isomers for the oxetanes obtained, the structures given are for the major products. Similar polyfluorinated oxetanes were reported in the following years. ^{233,235,236}

It was reported by Cook and Landrum ²³⁶ that under actinic irradiation (450 watt Hanovia high-pressure mercury lamp) hexafluoroacetone gave good yields of oxetanes with ethylene, vinyl fluoride and vinylidene fluoride. With vinyl and vinylidene fluoride it was possible to isolate and identify both possible adducts and also determine the isomer distribution.

Free radical addition of aliphatic aldehydes to fluorinated olefins has been shown to yield ketones derived from addition of an acyl radical to the terminal carbon of the double bond. ^{237,238} Bissell and Fields have shown that under certain circumstances ketones and oxetanes can be produced simultaneously. ²³⁹ They reported that ultraviolet irradiation in the gas phase of mixtures of acetaldehyde and a fluorinated ethylene resulted in the formation of complex mixtures from which the ketone derived from addition of an acetyl radical to the CF₂ group of the olefin and the oxetane derived from cycloaddition of the aldehyde to the olefin could be obtained. Four olefins, tetrafluoroethylene, chlorotrifluoroethylene, bromotrifluoroethylene and 1,1-dichloro-2,2-difluoroethylene were studied. The major product in each case

was the ketone. The reactor consisted of a 5 litre flask into which a water-cooled quartz well was inserted, a 100 watt high-pressure mercury vapour lamp was suspended in the well at the centre of the flask. Gaseous reactants were introduced through a vacuum manifold attached to a side arm of the reactor. The reactants were introduced from supply cylinders until the desired pressure was obtained. The mixture was irradiated until the pressure had fallen to half its initial value; this did not represent complete consumption of either component, but the yields of both ketone and oxetane actually decreased if the irradiation time was extended further. Sizeable quantities of high boiling telomeric materials accumulated in the bottom of the reactor. Perfluorinated oxetanes, in other words oxetanes with either fluorine or perfluorinated groups attached to the ring carbons were photochemically synthesized for the first time by Harris and Coffman in 1961.²⁴⁰ Before the publication of their work the only known example of this class was hexafluorooxetane itself, prepared by the electrolytic fluorination of the parent compound, oxetane.²⁴¹ Syntheses were carried out either at atmospheric pressure or in glass ampoules depending on the b.p.'s of the reactants. In the case of atmospheric pressure reactions, the reactor consisted of a vertical quartz tube (2" x 10") fitted with a magnetic stirrer, a gas inlet adaptor and a large acetone/solid carbon dioxide cooled condenser vented through a trap, also cooled by acetone/solid carbon dioxide, the exit of which was fitted with a T-tube through which a slow stream of nitrogen passed. The ultraviolet radiation source consisted of a helix shaped (4" x 2½") low pressure mercury lamp which was fitted around the quartz reaction tube so that its radiation impinged primarily upon the liquid portion of the reaction mixture. Alternatively, a glass ampoule was partially filled with the fluorocarbonyl compound and attached to a shaker. While being shaken, the ampoule and its contents were irradiated with two General Electric H - 85 C - 3 lamps placed as close to the bottle as possible. In both cases, products were separated chromatographically and examined by spectroscopic techniques.

Some perfluorooxetanes prepared by the methods described above are listed in Table 4.1. It can be seen from this table that percentage yields of oxetanes prepared from acid or diacid fluorides are very high, in some cases as high as 91%. No by-products from these reactions were reported by the authors.²⁴⁰ In contrast to this behaviour, irradiation of sym-dichlorotetrafluoroacetone and hexafluoropropene for two days in an ampoule lead to the formation of the corresponding oxetane (12%), two unidentified involatile compounds, CF_2Cl_2 (1%), CO , CO_2 and SiF_4 .²⁴⁰

In a following publication, Harris investigated the photoreactions of acylfluorides in the presence of fluoroolefins;²¹⁹ he stated categorically that 'irradiation of mixtures of polyfluoroacylfluorides and fluoroolefins leads primarily to the formation of oxetanes; for example, perfluorobutanoyl fluoride and hexafluoropropylene give the cis and trans isomers of 2-perfluoro-n-propyl-3-trifluoromethyltetrafluorooxetane (Figure 4.12). Virtually no

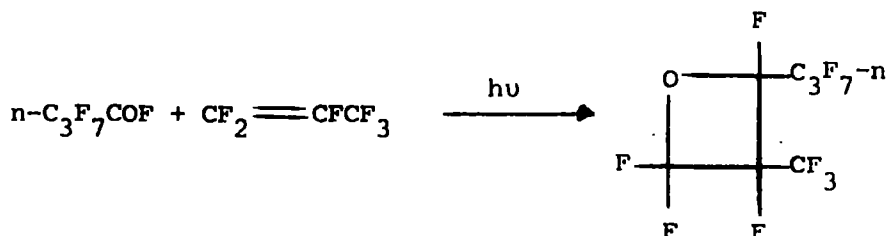


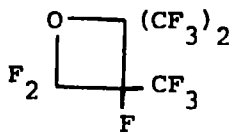
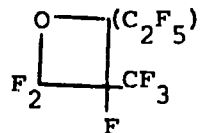
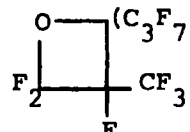
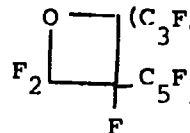
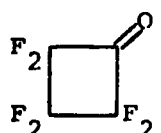
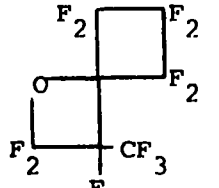
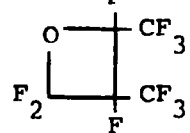
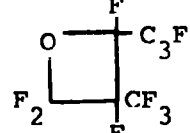
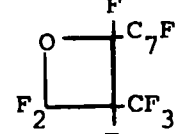
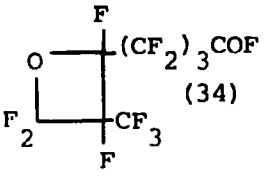
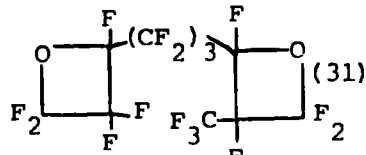
Figure 4.12

other products are formed.'

When the photoreaction of hexafluoropropylene with perfluoroacylchlorides was examined however, a variety of products was formed. Thus perfluorobutanoyl chloride and hexafluoropropylene yielded at least ten products (Figure 4.13).²⁴⁰ In contrast to the reactions of fluoroacyl fluorides with terminal fluoroolefins (in which 1:1 adducts were virtually the exclusive products) only small yields of 1:1 adducts were found. There were also

Table 4.1.²⁴⁰

Ultraviolet cycloadditions of perfluorocarbonyl compounds to
perfluoroolefins

<u>Carbonyl compound</u>	<u>Olefin</u>	<u>Period of irradiation (days)</u>	<u>Oxetane (% yield)</u>
CF ₃ COCF ₃ 39g (0.235m)	CF ₂ =CFCF ₃ 43g (0.286m)	7	 (50)
C ₂ F ₅ CO C ₂ F ₆ 43g (0.162m)	CF ₂ =CFCF ₃ 35g (0.233m)	5	 (46)
C ₃ F ₇ CO C ₃ F ₇ 45g (0.131m)	CF ₂ =CFCF ₃ 40g (0.267m)	8	 (62)
C ₃ F ₇ CO C ₃ F ₇ 45g (0.123m)	CF ₂ =CFC ₅ F ₁₁ 45g (0.129m)	12	 (32)
 17g (0.133m)	CF ₂ =CFCF ₃ 35g (0.233m)	4	 (33)
CF ₃ COF 56g (0.483m)	CF ₂ =CFCF ₃ 95g (0.633m)	8	 (38)
C ₃ F ₇ COF 35g (0.162m)	CF ₂ =CFCF ₃ 68g (0.453m)	7	 (73)
C ₇ F ₁₅ COF 40g (0.113m)	CF ₂ =CFCF ₃ 50g (0.333m)	13	 (91)
FOC(CF ₂) ₃ COF 26g (0.107m)	CF ₂ =CFCF ₃ 60g (0.40m)	7	 (34)
			and  (31)

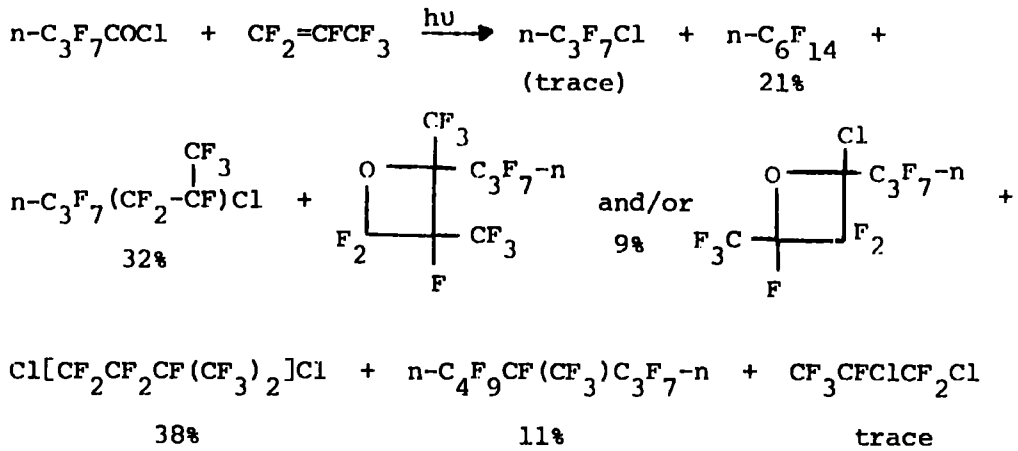


Figure 4.13

relatively small amounts of the products obtained from the photolysis of acyl chloride itself. The bulk of the products was thought to arise from sequences beginning with additions of the acyl chloride photolysis fragments (i.e. the chlorine atom and the perfluoroalkyl radical) to the olefin.²⁴⁰

A similar behaviour was observed in the photoreaction between perfluorobutanoylbromide and perfluoropropylene (Figure 4.14).

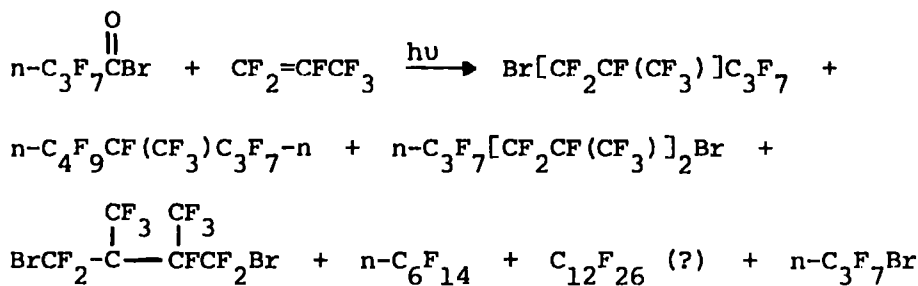


Figure 4.14

The acyl halide/hexafluoropropylene reactions were all carried out in the same manner. The reactor consisted of a vertical quartz tube (2 x 10 in.) fitted with a magnetic stirrer, a large acetone-dry ice cooled condenser vented through a dry ice cooled trap, the exit of which was fitted with a T-tube through which a slow stream of nitrogen passed. The ultraviolet radiation source consisted of a helix shaped (4 x 2.5 in.) low pressure mercury resonance lamp which fitted around the quartz reactor so that its radiation

impinged primarily upon the liquid portion of the reaction mixture.

4.4. The photolysis of acyl fluorides

A knowledge of the band positions and intensities forms the starting point for any photochemical investigation. In the ultraviolet spectra of perfluoroacyl halides a marked bathochromic shift of the maximum of the $n \rightarrow \pi^*$ transition is observed on passing from the fluorides through chlorides to the bromides.²¹⁹ The spectral characteristics of the perfluorobutanoyl halides are recorded in Table 4.2 as an example.

As early as 1959, Haszeldine and Nyman demonstrated that irradiation of chlorodifluoroacetylfluoride gave mainly 1,2-dichlorotetrafluoroethane and dichlorodifluoromethane with small amounts of several other materials

Table 4.2

Absorption bands of perfluorobutyryl halides in the u.v. region

$n\text{-C}_3\text{F}_7\text{COX}$	Gaseous phase λ_{max} (nm) (ϵ)	Cyclohexane λ_{max} (nm) (ϵ)
F	215 (66)	-
Cl	258 (38); 266 (37)	259 (46.5); 266 (46)
Br	-	217 (692); 273 (56)

including carbonylfluoride, carbonylchloridefluoride, and silicon tetrafluoride (Figure 4.15).

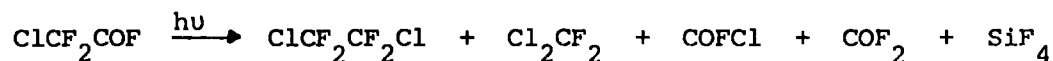


Figure 4.15

More detailed photolytic studies of polyfluoroacylfluorides were reported by Harris;²¹⁹ the experimental procedure was the same as in the acylhalide/perfluoropropene irradiations (see Section 4.3). Polyfluoroalkanes were the

main products obtained from these photolyses; for example, from the irradiation of perfluorobutanoylfluoride, the major product isolated was perfluoro-n-hexane. In addition a higher boiling fraction was obtained from which an ether was isolated having the structure $(n-C_3F_7)_2CFOC_3F_7-n$.

Analysis of the infrared spectra of the effluent gases indicated that they consisted of 5 - 15% COF_2 , traces of SiF_4 and C_3F_7H and the remainder was CO and CO_2 . These results were consistent with the scheme proposed by Harris (Figure 4.16). In this scheme the photoexcited acylfluoride molecule cleaves

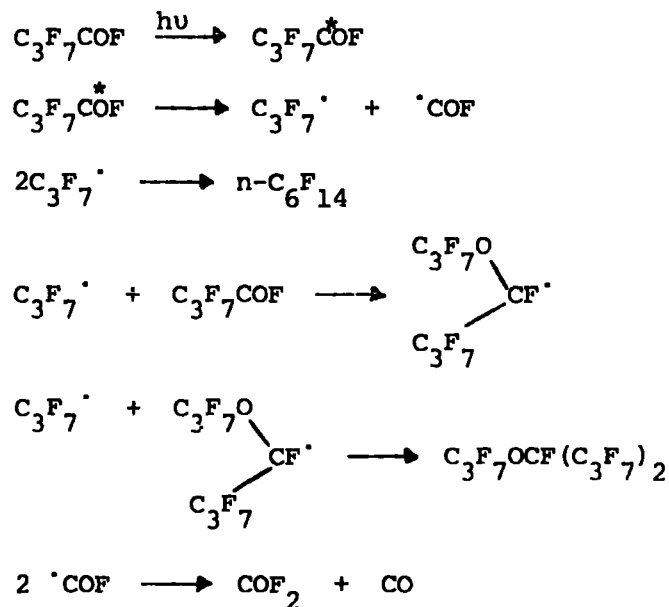


Figure 4.16: Scheme accounting for results of irradiating perfluorobutanoylfluoride

to give a perfluoropropyl radical and a fluoroformyl radical. Since no perfluoropropane was observed among the reaction products, it follows that the perfluoropropyl radical does not abstract a fluorine atom from the acylfluoride. It is also probable that the alternative mode of cleavage of the excited acylfluoride molecule (i.e. $C_3F_7\overset{*}{COF} \longrightarrow C_3F_7CO\cdot + F\cdot$) does not occur. To a major extent the perfluoropropyl radical reacts with another such radical to give perfluorohexane; however it can also attack a molecule of the acylfluoride at the oxygen to give the radical $C_3F_7\overset{\cdot}{O}CFC_3F_7$ which eventually combines with another perfluoropropyl radical to give an ether. The fate of

the $\cdot\text{COF}$ radical produced in the photolysis was indicated by the detection of CO_2 , CO and COF_2 in the effluent gases. The radical may disproportionate directly to COF_2 and CO as indicated in Figure 4.16 or possibly it dimerizes to give oxalyl fluoride which then undergoes disproportionation. The CO_2 and SiF_4 presumably arise by reaction of COF_2 , oxalyl fluoride or the $\cdot\text{COF}$ radical with the walls of the reaction vessel. From the irradiation of a mixture of perfluorobutanoyl fluoride and perfluorooctanoyl fluoride, perfluoro-n-hexane, -decane, and -tetradecane were isolated as expected on the basis of the reaction scheme given above.

Irradiation of a diacyl fluoride, perfluoroglutaryl fluoride was carried out under the same experimental conditions for four days. At the end of this time, the reaction mixture was completely solid. Two kinds of white solid were evident: i) hard brittle material stuck to the sides of the reactor and ii) somewhat 'mushy' solid from the centre portion of the reaction vessel. The total yield of recovered solid was roughly 45% on a weight basis. Both solids reacted with moist air to give, after several days, products melting at $190^\circ - 300^\circ$ and $100^\circ - 195^\circ$ respectively. The nature of these materials was not extensively investigated by the author, who assumed that they were largely long-chain dicarboxylic acid fluorides of structure $\text{FOC}(\text{CF}_2)_3\text{nCOF}$.

In contrast to the behaviour of perfluoroacyl fluorides, the irradiation of a perfluoroacyl chloride leads to decarbonylation resulting primarily in the formation of a polyfluoroalkyl chloride.²⁴⁰ Cleavage of the C - Cl bond seems to occur with the formation of $\text{R}\cdot\text{CO}$ and $\text{Cl}\cdot$ radicals. The photolysis of hexafluoroglutaryl chloride apparently proceeds in a manner analogous to that of monofunctional acid chlorides yielding 1,3-dichloro-hexafluoropropane as the major product along with some 1,6-dichloroperfluorohexane. The relative proportion of the product resulting from dimerization of radicals is significantly larger than for monofunctional acyl chlorides. No products with more than six carbons were isolated and no perfluorocyclopropane was found.²⁴⁰

From the photolyses of polyfluoroacylbromides only the decarbonylation products, perfluoroalkylbromides were isolated. For example, from 5H-octa-fluorovaleryl bromide, 4H-octafluorobutyl bromide (93%) and CO were obtained.²⁴⁰

The differences in behaviour exhibited by the three types of acyl halides upon irradiation can be related to the relative strengths of the C - X bonds in the compounds. In the photolysis of the acyl fluorides, in which this bond is the strongest, no products are found whose formation would demand its rupture to yield a fluorine atom.

4.5. Original idea

Application of the Paternò-Büchi reaction to polymer syntheses in the aromatic diketone/diolefin series was only partly successful for reasons discussed in Section 4.2. On the other hand, literature information on the behaviour of the perfluoroacyl fluoride/perfluoroolefin system on exposure to ultraviolet irradiation (Sections 4.3 and 4.4) made this system appear an attractive one for use in linear polymer synthesis. Thus, the use of liquid perfluoro reactants would eliminate the complications introduced by use of solvents. Irradiations of precisely equimolar mixtures of perfluorodiacid fluorides/perfluorodiolefins would be expected to yield linear high molecular weight perfluoropolyoxetanes since no side reactions seem to compete with oxetane formation.²⁴⁰ Such precisely metered mixtures would be expected to be easily formed and transferred into quartz vessels using conventional vacuum line techniques. Oxygen, which dissolves very readily in fluorocarbons, could then be excluded from the mixture by successive freeze - pump - thaw cycles. Products would be expected to be transparent in the energy range required for photopolymerization. The main advantage of the perfluorodiacid fluoride/perfluoroolefin system however, lies in the absence of competing hydrogen abstraction reactions by the photoexcited carbonyl. The only reaction which could interfere with polymer formation is the telomerization of the acid

fluoride,^{240,243} which would destroy the required 1:1 stoichiometry of the olefin and acylfluoride groups. If this reaction occurred the attainable d.p. would be limited; however there was a categorical statement in the literature that under appropriate conditions oxetane formation was the exclusive reaction.²⁴⁰

As briefly mentioned in Section 1.7 the photochemistry of carbonyl compounds is complex, it is also an area of considerable activity and it is therefore necessary for workers using carbonyl photochemistry as a synthetic method to be ready to modify procedures in the light of new information. It is for example, established that the detailed course of a photochemical reaction is dependent on the nature of incident light (wavelength and monochromaticity) and the physical conditions of the reagents (gas, solid, solution, nature of solvent, presence of sensitizers or quenchers). Thus an approach to the investigation of step-growth photopolymerizations leading to perfluoro or highly fluorinated polyoxetanes would involve a compromise between choosing systems which could yield interesting polymers if appropriate reaction conditions could be found and choosing systems known to proceed in high yield and conversion and would therefore be more likely to yield polymers within a reasonable time.

The first objective of the exercise was therefore the photochemical examination of simple systems, by irradiating a well-characterized and vigorously purified diacid fluoride in the presence of an olefin. As already mentioned in Section 1.6, perfluoroglutaryl fluoride was chosen, partly because of the fact that its photochemistry has been documented and there seem to be no reasons which would exclude it as a candidate for possible photopolymerization attempts,²⁴⁰ and partly because of the considerable expertise in its preparation available in this Department. Two different perfluoro-olefins were also used, a cyclic one and a straight chain terminal one. Results obtained will be discussed in Section 4.6.

4.6. Experimental

4.6.a. Starting materials

Perfluoroglutaryl fluoride was prepared by the route outlined in

Figure 4.17. Typical results for the various stages in this synthesis are as

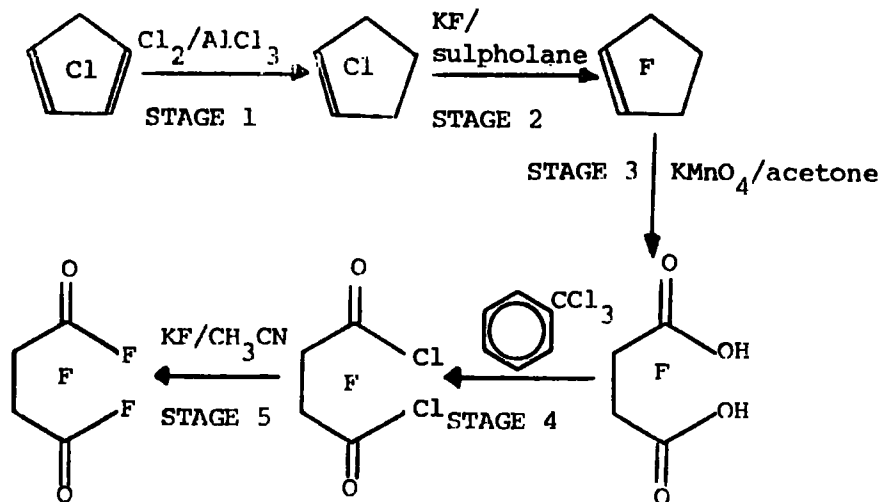


Figure 4.17

follows:-

Stage 1. Perchlorocyclopentadiene (780g, 2.85 moles) and aluminium trichloride (121g, 0.92 moles) were mixed in a 1 l. R.B. flask using a mechanical stirrer. Chlorine was passed into the mixture; heat was applied initially to start the reaction and thereafter chlorine was passed at such a rate that the temperature of the mixture was maintained at $\sim 45^\circ\text{C}$ by the exothermicity of the reaction. The flow of chlorine was stopped when the reaction temperature fell below 30°C . The black solid obtained was treated with large excess of water until a yellow oil appeared. Recrystallization of this oil from ethanol gave 649g of octachlorocyclopentene (66%) identified by i.r. spectroscopy ($\bar{\nu}_{\text{max}}$ 1620, 1200, 770 cm^{-1}).

Stage 2. Octachlorocyclopentene (350g, 1.02 moles) and 942g of dry potassium fluoride were mixed with 2.5 litres of sulpholane in a 5 l. R.B. flask using a mechanical stirrer. Temperature was raised and maintained at $180^\circ - 185^\circ$ for about $1\frac{1}{2}$ days. Product formed was carried via nitrogen stream and collected in liquid air traps. Fractional distillation of the crude

product gave 129g of octafluorocyclopentene (60%) identified by i.r. spectroscopy ($\bar{\nu}_{\max}$ 1780, 1720, 1410, 1340, 1310, 1235, 1180, 1000, 900).

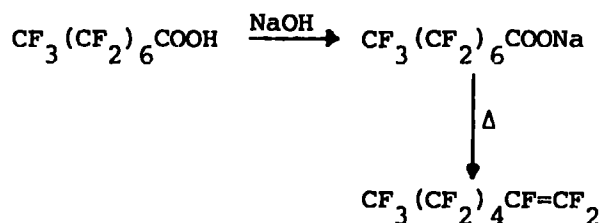
Stage 3. 300g of potassium permanganate (1.90 moles) were added in small portions to a stirred solution of octafluorocyclopentene (100g, 0.47 moles) in 2 litres of dry acetone. Temperature was lowered by means of an acetone/dricold bath and maintained at below -20°C . On completion of the permanganate addition, solution was allowed to warm up to room temperature and then reflux for 2 hours. 2 litres of water were then added and the mixture was allowed to stand overnight. It was then filtered, acetone was removed, the aqueous suspension was acidified with dil. H_2SO_4 and decolourised with SO_2 in a polythene bag. An ethereal solution was then obtained by continuous extraction overnight, dried over MgSO_4 and filtered. After removal of ether, material was obtained by vacuum distillation (0.01 mm. Hg/ 140°C). 100g were kept for the next stage. Perfluoroglutaric acid was identified by i.r. spectroscopy ($\bar{\nu}_{\max}$ 3500, 1780, 1180 cm^{-1}).

Stage 4. 140g (0.73 moles) of perfluoro glutaric acid were mixed with 350g (1.79 moles) of previously distilled benzotrichloride in a 1 l. R.B. flask fitted with a water condenser/acetone-dricold cold finger system connected to a H_2SO_4 bubbler. Temperature was raised up to 212° using a lissapol nx bath while stirring was provided by means of a magnetic stirrer. After about 5 hrs. of boiling, the apparatus was modified for fractional distillation and mixture was distilled (3 foot column/glass helices). The 78° - 160° fraction was retained and found to contain mainly one component by g.l.c. (Col. A/ 100°C). Perfluoroglutaryl chloride thus obtained (144g, 90%) was identified by i.r. spectroscopy ($\bar{\nu}_{\max}$ 1810, 1200, 1110, 990, 890, 805 cm^{-1}).

Stage 5. Perfluoroglutarylchloride (258g, 1.14 moles) was slowly added to a solution of 1 Kg. of dry potassium fluoride in 2.5 litres of dry acetonitrile (fractionated from P_2O_5) in a 5 l. R.B. flask using a mechanical stirrer. On addition of the acid chloride, the pot temperature rose; the

reaction was assumed to have finished when, after adding all the acid chloride the pot temperature went down to room temperature. The apparatus was then modified for fractionation (3 foot column/glass helices); the 45° - 48° fraction was found to contain mainly acid fluoride and some acetonitrile by g.l.c. (Col. A/room temperature). Infrared analysis of the product obtained (156g, 69%) revealed the presence of some acid chloride - peak at 1810 cm.⁻¹ ($\bar{\nu}_{\max}$: 1380, 1200, 1135, 1010, 900 cm.⁻¹).

Perfluorohept-1-ene was synthesized by pyrolysing the corresponding perfluorocarboxylic acid salt:²⁴⁴



Perfluoro-octanoic acid (100g, 0.24 moles) was neutralised using 9.66g of NaOH in 100 mls of water. Salt was dried by pumping under vacuum for 8 hrs. Product obtained (103g, 99%) was pyrolysed (400°C/760 mm Hg) for about 1 hr. Resulting colourless liquid was washed with aq. K₂CO₃, degassed and vacuum transferred from P₂O₅; g.l.c. at room temperature (Col. A) showed the product to be pure. Terminal olefin thus obtained was identified by i.r. spectroscopy ($\bar{\nu}_{\max}$: 1780, 1370, 1320, 1200, 1070, 940 cm.⁻¹). Yield after purification: 71g (86%).

Perfluorocyclohexene was provided. It was obtained from the dehydrofluorination of undecafluorocyclohexane. It was found to be pure by g.l.c. (Col. A/70°C) and characterized by i.r. spectroscopy ($\bar{\nu}_{\max}$: 1740, 1370, 1300, 1260, 1190, 1150, 1110, 1010, 980 cm.⁻¹).

4.6.b. Irradiations

General Procedure

Starting materials were accurately weighed so as to give a 2:1 olefin/acid fluoride molar ratio and were introduced into a flask containing P₂O₅.

They were degassed by means of 4 - 5 freeze - pump - thaw cycles on a conventional vacuum line and then vacuum transferred into cylindrical quartz vessels and sealed under reduced pressure (10^{-3} torr). After irradiations, tubes were frozen in liquid air, hot spotted, opened and connected through two traps to a conventional vacuum line. The two traps were connected to the vessel in series, the one nearest to it being at -78°C (acetone/dry ice bath) and the other one being at -178°C (liquid air). Products were thus separated by volatility.

4.6.c. Results (see Table 4.3)

4.7. Discussion

The results obtained indicate that despite literature reports on successful perfluoro and polyfluorooxetane syntheses^{219,233,234,235,236,240} often in high yields, none of the reactions attempted here gave a detectable amount of oxetane. In most cases telomers of acid fluoride were obtained in very low yield, in addition to low volatility products.

Irradiation of perfluorohept-1-ene by itself using the 5-w Hanovia low pressure lamp which definitely has an output at 185nm where the olefin might be expected to absorb (Expt. 9, Table 4.3) resulted in a 26% conversion to a product which, on the basis of g.l.c. analysis and infrared spectroscopy seemed likely to be a mixture of isomers and telomers of the starting olefin. Isomerization of fluoroolefins via fluorine atom shifts has been reported recently by Haszeldine for the irradiation of perfluoro-2,3-dimethylbut-2-ene.²⁴⁵ The low temperature reaction (Experiment 5) was carried out (after some earlier attempts had failed to give oxetanes) because it was noted that almost all examples reported in the literature occurred at temperatures well below ambient. It seemed possible that in our experiments the diradical on the route to oxetane formation may have either reverted to monomers or if the oxetane was formed it may have been in a high vibrational energy state and

Table 4.3




Expt.	Starting Materials ^a		Lamp ^d	Time (Hrs.)	Temp (°C)	Products ^d		Comments on Low Volatility Products	
	Olefin	Acid Fluoride				Starting Mat. Recovered	-15°C Trap		Low Volatility Materials
1	$F_3C(CF_2)_4CF=CF_2$	$OFC(CF_2)_3CFO$	A	89.50	55	87.9	6.9	5.0	Mobile liquid containing at least 6 components by g.l.c.k
2	$F_3C(CF_2)_4CF=CF_2$	$OFC(CF_2)_3CFO$	B	65.60	40	74.7	25.3		
3	$F_3C(CF_2)_4CF=CF_2$	$OFC(CF_2)_3CFO$	C	160.75	30	70.6	19.0	10.0	Orange wax/mixture of at least 6 components by g.l.c.l
4	$F_3C(CF_2)_4CF=CF_2$	$OFC(CF_2)_3CFO$	D	91.00	300		53.3	46.6	E
5	$F_3C(CF_2)_4CF=CF_2$	$OFC(CF_2)_3CFO$	A	224.00	+8+-20	92.5	3.1	4.3	Heavy yellow-brown oil
6		$OFC(CF_2)_3CFO$	A	25.00	55	94.2	2.2	3.5	Decomposed thermally at high T giving 0.5% v. volatile gases and yellow liquid (b. 140°) - 3 components (g.l.c.) ^f
7		$OFC(CF_2)_3CFO$	A	69.50	55	92.1	2.1	5.7	Yellow liquid - gave on standing 24.4% of its mass as an oil ^g
8		$OFC(CF_2)_3CFO$	B	65.80	40	57.1	20.0	22.8	Gave 19.3% of its mass as a waxy solid ^h
9	$F_3C(CF_2)_4CF=CF_2$		C	160.75	30	74.0 ^e		26.0	Most probably telomers of the olefin ⁱ
10	$F_3C(CF_2)_4CF=CF_2$		A	224.00	+8+-20 ^c	100.0			No change in the olefin
11		$OFC(CF_2)_3CFO$	A	224.00	+8+-20 ^c	75.0	20.0	5.0	Orange waxy solid soluble in hot H ₂ O giving strong acid soln.

Table 4.3 (cont.)

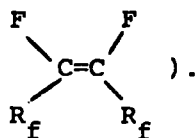
Footnotes: a. Olefin/acid fluoride ratio: 2:1.

- b. Lamp A: HANOVIA 450-W Hg Lamp
- Lamp B: RAYONET RPR-208 253.7nm
- Lamp C: HANOVIA PCR 1L/5W Low P Hg Lamp
- Lamp D: HANOVIA 125W medium P Hg Lamp

c. Using refrigerated methanol bath.

d. As % of total weight of starting materials

e. Plus isomers by i.r. evidence (peak at 1720 cm.^{-1})



f. Gc/MS examination of the 8 component mixture revealed the presence of a substance ($m/e \approx 469$) which could be either $\text{OFC}(\text{CF}_2)_6\text{CFO}$ or the 1:1 adduct. I.r. evidence (strong -COF absorption 1880 cm.^{-1}) seems to favour $\text{OFC}(\text{CF}_2)_6\text{CFO}$.

g. I.r. spectrum of oil showed strong -COF absorption (1880 cm.^{-1}) strong $\text{R}_f\text{-COOH}$ absorption (1780 cm.^{-1}) and strong bands around 1000 cm.^{-1} , characteristic of oxetanes.

h. Waxy solid obtained by treating involatile materials with CCl_4 . I.r. spectrum failed to reveal strong -COF band. Material slightly soluble in H_2O giving strongly acid solution ($\text{pH} = 1 \rightarrow 2$).

k. Gc trace (Col. A/ 30°). I.r. spectrum similar to that of starting materials.

l. Orange wax soluble in hot H_2O (strongly acidic solution), in acetone, insoluble in Et_2O , CCl_4 . I.r. spectrum shows the presence of strong -COF absorption (1880 cm.^{-1}).

m. Low volatility materials heated at $200^\circ/0.01\text{ mm Hg}$ to yield a yellow oil and a remaining red brown viscous liquid. I.r. spectra of both materials appeared very similar. No -COF absorption around 1880 cm.^{-1} , strong band at 1720 cm.^{-1} . Probably telomer and/or isomers of perfluoro olefin.

n. I.r. examination of low volatility fraction showed a much stronger peak at 1720 cm.^{-1} and a smaller peak at 1880^{-1} (terminal perfluoroolefin). Fraction heated at $280^\circ/0.01\text{ mm Hg}$ for 2 hrs. to yield a colourless fairly mobile liquid and a yellowish oil displaying similar i.r. and n.m.r. spectra. Gc traces (Col. O_{30} at 165°) show 4 and 7 components respectively - probably different telomers of the perfluoroolefin.

itself have cleaved. However, even at -20° no detectable amount of oxetane was formed. The interesting finding was that at low temperatures no olefin isomerization was observed either (Experiment 10, Table 4.3).

Since literature reports originate from reputable establishments, are well documented and have been repeated and extended by several other workers, the possibility of unreliable reports can be dismissed, and the reasons for our failure require careful analysis. An obvious question is whether lamps used had sufficient output at the required wavelengths and this is not easy to deal with. The fact that telomerization reactions of both acid fluoride and olefin components have been observed can be taken as good evidence that light was absorbed by monomers to some extent. Nevertheless, it would be more satisfactory if a high intensity light source incorporating a broad band monochromator were available for preparative work which requires wavelengths shorter than the 254nm band of the mercury lamp; we were unable to obtain such equipment. The absorption of perfluoroacylfluorides is reported as $\lambda_{\text{max}} 215\text{nm}$ ($\epsilon - 66$),²¹⁹ whereas the short wavelength end of the spectrum of a mercury lamp consists predominantly of lines at 185, 238, 248 and 254nm. Overlap between the emission of the lamp and the COF absorption will therefore be poor, which possibly accounts for the long (several days) irradiation periods reported for successful perfluoro-oxetane syntheses despite the use of high powered lamps.^{219,233,234,235,240} On balance, it seems that since others have successfully used mercury lamps, overlap between lamp emission and COF absorption was not the main cause of the failure to synthesize oxetanes, however a more readily regulated system would offer advantages to any future worker in this field.

Having considered questions related to the 'First Law of Photochemistry', doubts about the purity of reactants need attention. Perfluorohept-1-ene was identified by i.r., m.s., and n.m.r. spectroscopy. G.l.c. showed it to be reliably pure. Perfluorocyclohexene was also found to be pure by g.l.c.

As far as the purity of acid fluoride is concerned, it was known from the beginning to contain traces of acetonitrile (g.l.c. evidence), which appears not to quench the carbonyl triplet.²⁹ Careful fractionation under N_2 (using a 3 foot column packed with 'Dixon gauzes') before use, afforded material, which, on g.l.c. examination, appeared to be free from acid chloride contamination. However, since purification of acid fluoride prepared by exchange fluorination is a very difficult task (mainly due to the formation of acid halide azeotropes, the possibility of acid chloride traces being present can not be excluded. If this were the case, it would be expected that R_fCOCl (λ_{max} 258nm, $\epsilon \sim 40$)²¹⁹ would overlap strongly with the intense 254nm band of the mercury lamp; consequently acyl chlorides or their photolysis products could be acting as quenchers for the excited state required for oxetane formation, or interfering with oxetane formation at some other stage.

In most cases, acid fluorides used for successful oxetane syntheses were prepared either from acids using SF_4 or by electrochemical fluorination.²¹⁹ One case of a successful use of an acid fluoride originating from an acid chloride has been reported.²¹⁹ However material was subsequently purified by distillation through a spinning-band still, as opposed to the fractional distillation procedure used by us.

Quartz glass used for the preparation of the irradiation tubes was examined by ultraviolet spectroscopy. It was found to be transparent in the region 220 - 300nm and virtually transparent in the region below 220nm; some slight absorption was observed at 215nm ($A = 0.13$) where the COF group is reported to absorb.²¹⁹ This however should not be significant for the rationalization of the failure to obtain the desired adducts.

Finally, a sample of perfluoroglutaryl fluoride used for irradiations was examined for Cl content by shaking it in a sealed tube with aqueous silver nitrate. Silver salts obtained after treatment did not contain AgCl amongst them. It should be kept in mind however that an efficient quencher can totally inhibit reaction at extremely low concentrations indeed,²⁴ as the bismaleimide

photopolymerization experiments by De Schryver, Feast and Smets have shown (Section 1.3).

4.8. Conclusions

The preliminary investigations carried out on the cycloaddition of perfluoroglutarylfluoride to the two perfluoroolefins under a variety of experimental conditions have served to illustrate how difficult this area of synthetic organic chemistry can be. The isolation of high purity $\text{FOC}(\text{CF}_2)_3\text{COF}$ following its preparation from the corresponding acid chloride in CH_3CN solvent appears to be a serious problem not easy to deal with by using straightforward fractional distillation techniques. High temperature irradiations seem to promote olefin telomerization, whereas low temperature irradiations seem to leave the olefin unchanged. It is difficult to be definite about the causes of failure to obtain the oxetanes. High purity starting materials are required for the serious investigation of any chemical reaction. This condition is imperative in the case of photochemical investigations. Bearing this in mind, and given the suspect purity of perfluoroglutarylfluoride any future examiner of the proposed syntheses reported in this chapter might do well to synthesize perfluoroglutarylfluoride by an alternative route so as to exclude the possibility of chloride contamination.

APPENDICES AND REFERENCES

APPENDIX A

APPARATUS, INSTRUMENTS AND GENERAL TECHNIQUES

Vacuum system

Freeze drying, pyrolyses, freeze-pump-thaw cycles, sublimations and vacuum distillations requiring pressures of the order of 10^{-3} mm Hg were undertaken with a conventional vacuum system incorporating a rotary oil pump and a mercury diffusion pump. Pressures as low as 10^{-6} mm Hg were achieved (where required) by means of a grease free, mercury-free vacuum line incorporating a rotary oil pump, an Edwards vapour pump, electronic pressure measuring devices and 'teflon' taps.

Infrared spectra - see Appendix B.

Mass spectra were measured with an A.E.I. MS9 spectrometer.

Ultraviolet spectra were recorded on a Unicam SP800 spectrophotometer.

N.m.r. spectra were recorded on a Bruker Spectrospin HX 90E High Resolution NMR spectrometer operating at 90MHz for ^1H and 22.635MHz for ^{13}C (ambient temperature).

Molecular weights were recorded on a Perkin-Elmer 115 Molecular Weight Apparatus utilizing the vapour pressure (isopiestic) method of determining the number average molecular weight of a solute in solution. All measurements were made in chloroform solution; benzil was used as standard for the determination of the instrument constant. An operating temperature of 37° was employed. Molecular weights could be measured with $\pm 2\%$ standard deviation.

Analytical vapour phase chromatography

A Perkin-Elmer 452 Gas Chromatograph was used with a column of di-n-decylphthalate/Celite (2.2m x 7mm dia.), hydrogen as carrier gas and a hot wire detector.

Carbon and hydrogen analyses were carried out with a Perkin-Elmer 240 Elemental Analyser.

Chromium analysis was carried out on a Perkin-Elmer 403 Atomic Absorption Spectrophotometer.

Thin layer chromatography was carried out using Merck 60F-254 silica gel plates and carefully purified solvents at room temperature.

Melting points were recorded using a Reichert melting point microscope and are uncorrected.

Irradiations.

Unless otherwise indicated, irradiations were carried out with Rayonet Type RS Preparative Photochemical Reactors (Models RPR-204 or RPR-208). Light sources were either RUL-3500 \AA lamps or RUL-3000 \AA . Temperatures were ca. 30 $^{\circ}$.

Reaction vessels were generally cylindrical in shape and approximately 7 diameters long.

APPENDIX B

INFRARED SPECTRA

Infrared spectra were recorded on a Perkin-Elmer 457 Grating Infrared Spectrophotometer (PE457) or a Perkin-Elmer 577 Grating Infrared Spectrophotometer (PE577). Spectra were run using KBr cells under the conditions designated by:

- (A) KBr disc
- (B) Nujol mull
- (C) Thin contact film

<u>Spectrum No.</u>	<u>Instrument</u>	<u>Discussed on page:</u>	<u>Material</u>	<u>Conditions</u>
1.	PE457	66	triphenylglycol isolated from irradiation of $\text{Ph}_2\text{CO} + \text{Ph}_2\text{CHOH}$	A
2.	PE457	84	triphenylglycol obtained via ground state syntheses (recrystallized)	A
3.	PE577	85	triphenylglycol obtained via ground state syntheses (sublimed)	A
4.	PE577	74	crude product from irr ⁿ of m-dibenzoylbenzene + hydrobenzoin in CH_2Cl_2	A
5.	PE577	76	product from diethyl-mesoxalate + PhLi	A
6.	PE457	84	α -phenylbenzoin	A

7.	PE457	69	product from irr ⁿ of α-phenyl- benzoin in benzene solution	A
8.	PE457	69	product from irr ⁿ of α-phenyl- benzoin + benzhydrol in benzene	A
9.	PE457	82	1,2,2,2-tetraphenylethanol (recrystallized)	B
10.	PE457	83	1,2,2,2-tetraphenylethanol (sublimed)	A
11.	PE457	82	m-dibenzoylbenzene	A
12.	PE577	113	m-bisbenzhydrylbenzene	A
13.	PE457	109	p-bisbenzhydrylbenzene	A
14.	PE457	112	oil distilled from products of p-bisbenzhydrylbenzene + HCOOH	C
15.	PE457	111	(PhCBrH) ₂ C ₆ H ₄ para isomer	B
16.	PE457	112	polymeric material formed on treatment of (PhCBrH) ₂ C ₆ H ₄ , para isomer, with Vitride in benzene	B
17.	PE577	110	(PhCClH) ₂ C ₆ H ₄ para isomer	A
18.	PE457	113	(PhCClH) ₂ C ₆ H ₄ meta isomer	A
19.	PE457	116	1,4-dibenzylbenzene	A
20.	PE457	116	1,3-dibenzylbenzene	A
21.	PE577	95	1,1,2,2-tetraphenylethanol	A

Irradiations of equimolar amounts of m-dibenzoylbenzene (DBB) and either p-dibenzylbenzene (p-dbb) or m-dibenzylbenzene (m-dbb).

22.	PE457	117	DBB/p-dbb: yellow product from preliminary investigation (24 hrs. irradiation)	A
23.	PE457	119	DBB/p-dbb: typical spectrum of white precipitate	A
24.	PE457	119	DBB/m-dbb: typical spectrum of white precipitate	A
25.	PE457	121	DBB/p-dbb: typical spectrum of yellow polymeric material (578 hrs. irradiation)	A
26.	PE457	122	DBB/m-dbb: typical spectrum of yellow polymeric material (578 hrs. irradiation)	A
27	PE457	128	black tar obtained from pyrolysis of yellow polymeric material from DBB/p-dbb (sample O)	B
28.	PE457	131	product from treatment of sample (O) with acetic acid/iodine in benzene	A

Photoreduction of dialdehydes

29. PE457 155 product from irrⁿ of tere- A
phthalaldehyde in isopropanol/
benzene
30. PE457 155 product from irrⁿ of iso- A
phthalaldehyde in isopropanol/
benzene

The benzaldehyde photoproduct

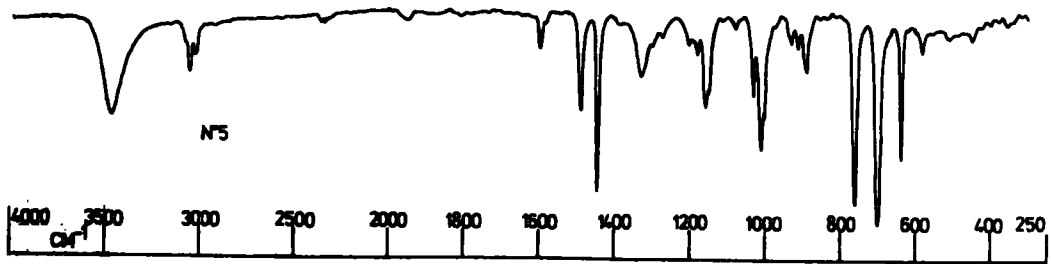
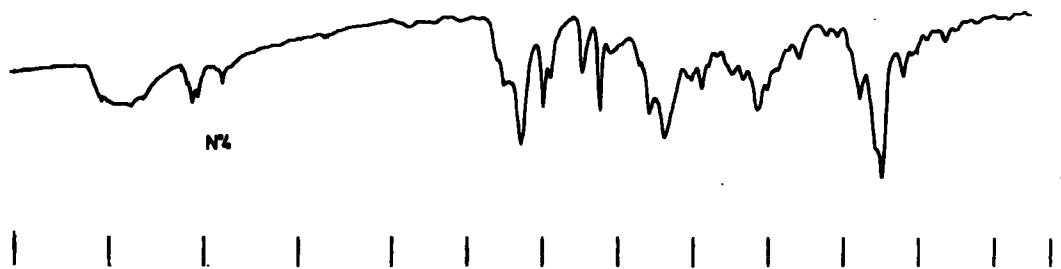
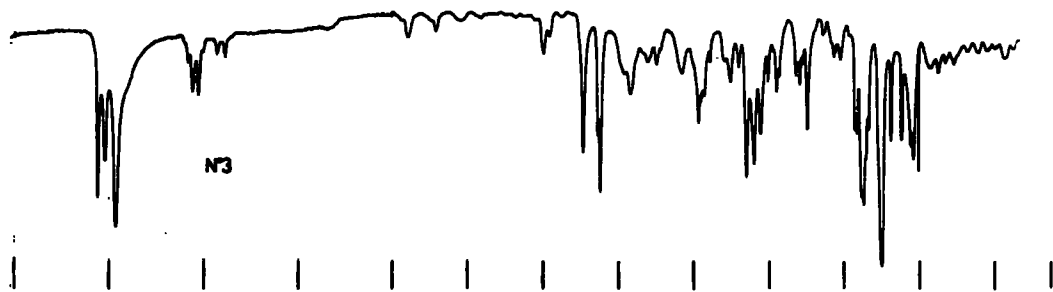
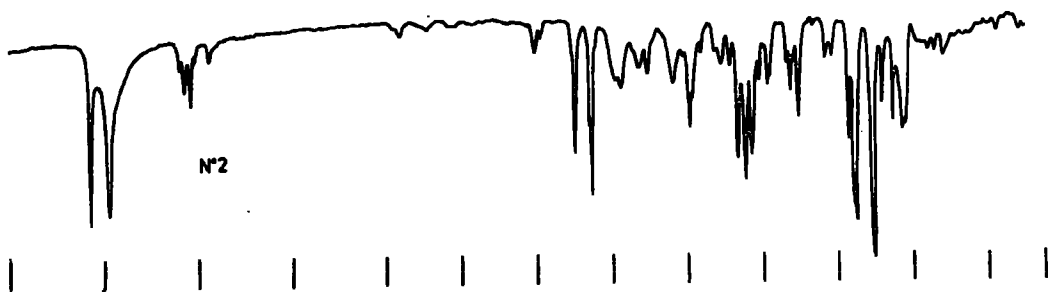
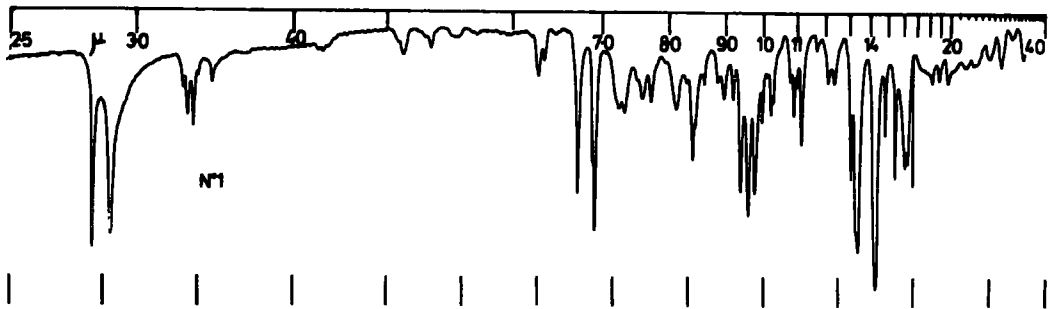
31. PE457 160 Typical spectrum of the A
benzaldehyde photoproduct (BPP)
32. PE457 163 product from BPP $\xrightarrow[\text{dioxane}]{\text{NaBH}_4}$ A
33. PE457 163 product from BPP $\xrightarrow[\text{Benzene}]{\text{Vitride}}$ A
34. PE457 162 product from BPP $\xrightarrow[\text{chloride}]{\text{acetyl-}}$ A
35. PE577 163 product from BPP $\xrightarrow[\text{H}^+]{\text{dichromate}}$ A
(no Cr found)
36. PE457 164 product from BPP $\xrightarrow[\text{H}^+]{\text{dichromate}}$ A
(Cr content 6.27%)
37. PE457 164 product from BPP $\xrightarrow[\text{H}^+]{\text{dichromate}}$ B
(Cr content 1.28%)
38. PE457 163 product from BPP $\xrightarrow{6\text{N H}_2\text{SO}_4}$ B
39. PE457 160 BPP in CCl₄ solution

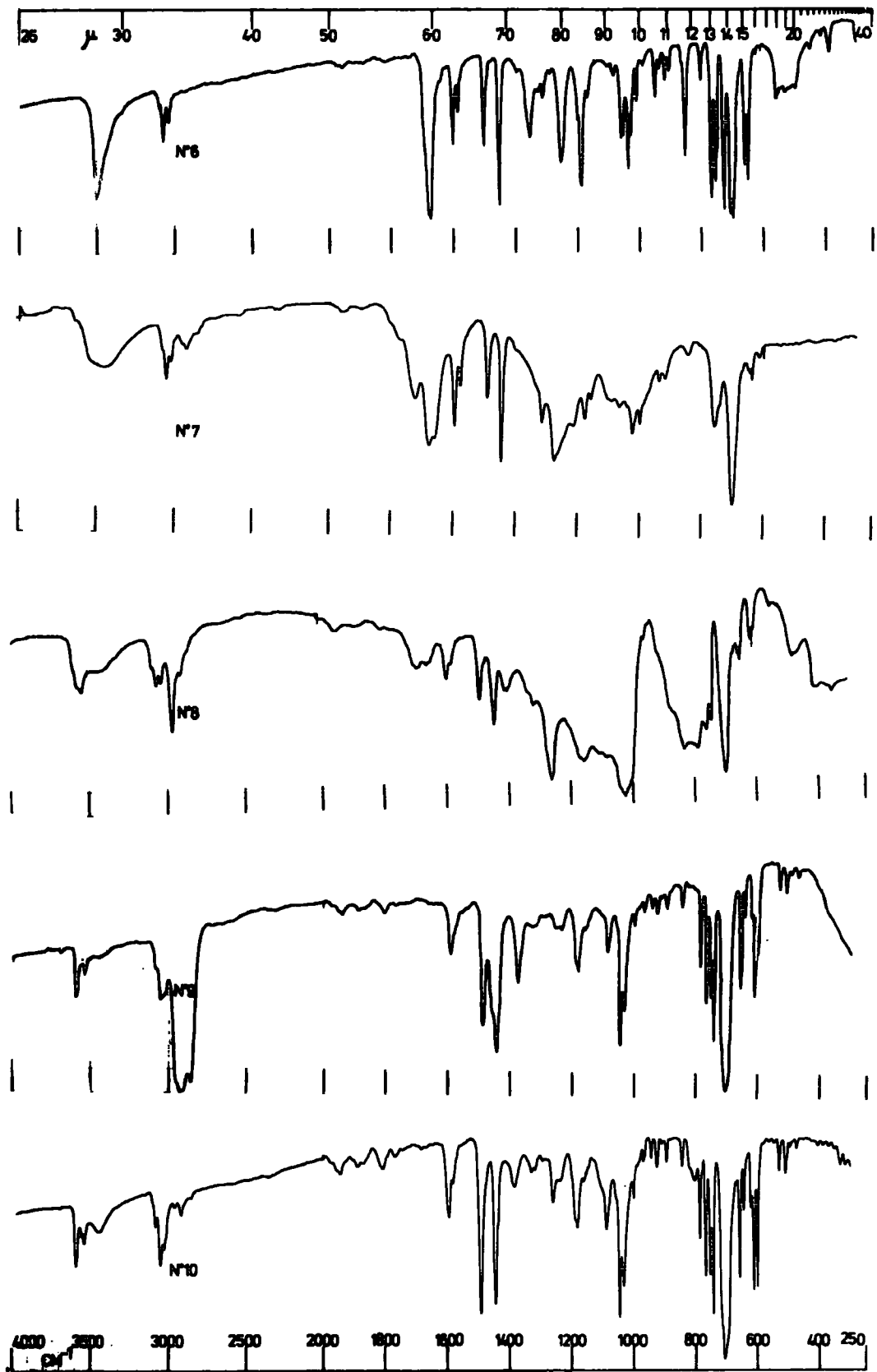
A: Pure CCl₄

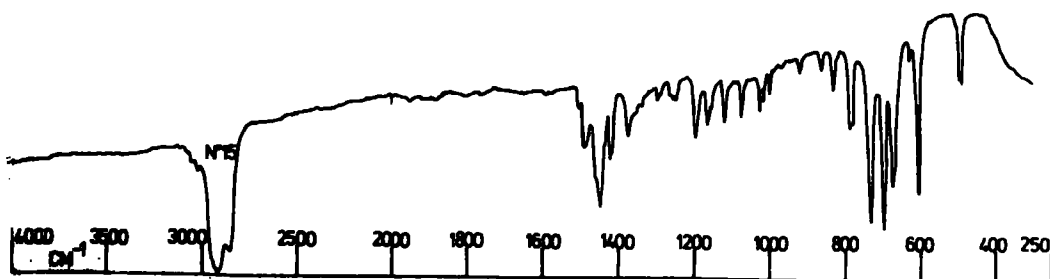
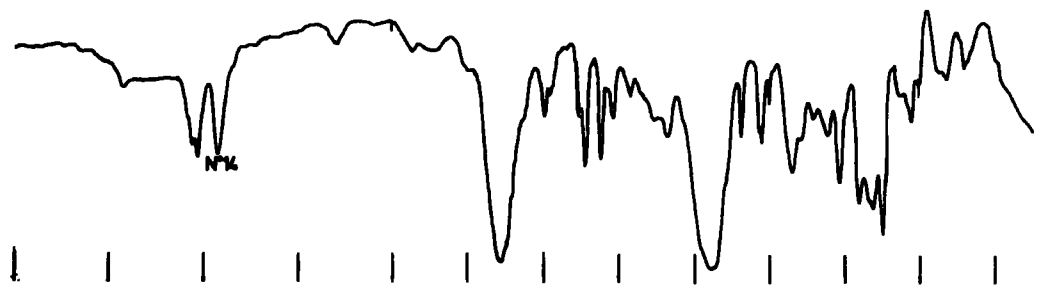
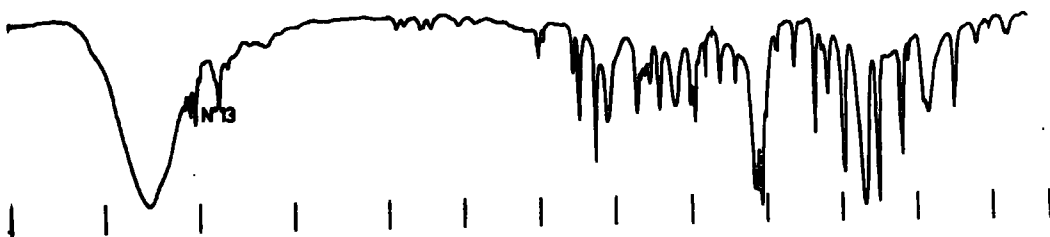
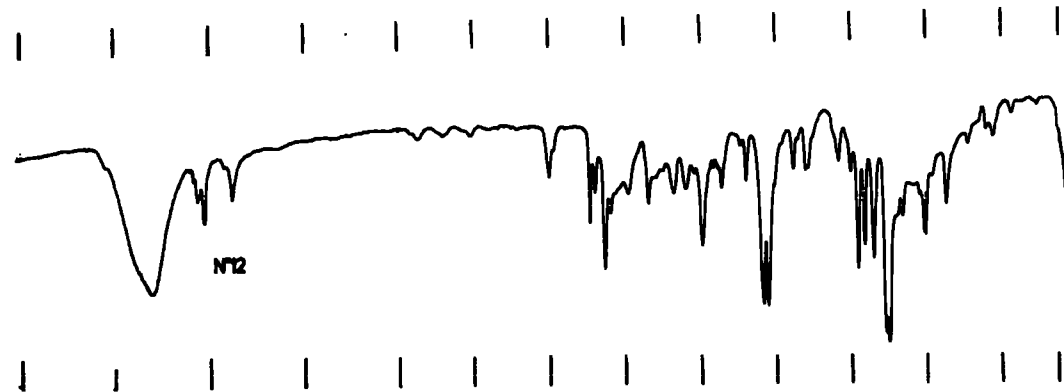
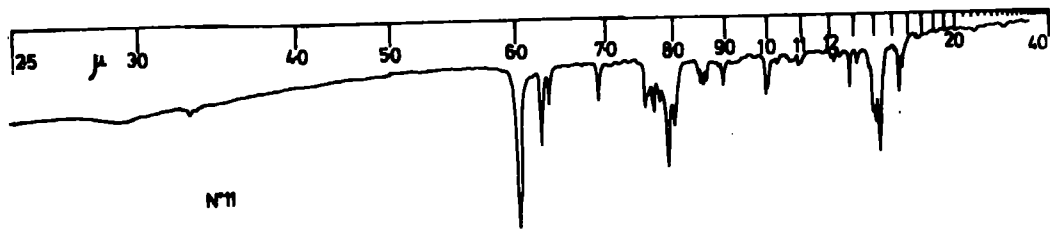
B: 75% Pure CCl₄/25% saturated soln. of BPP in CCl₄

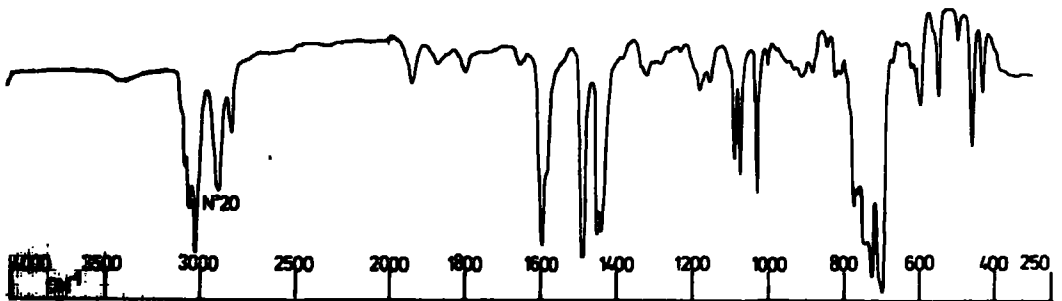
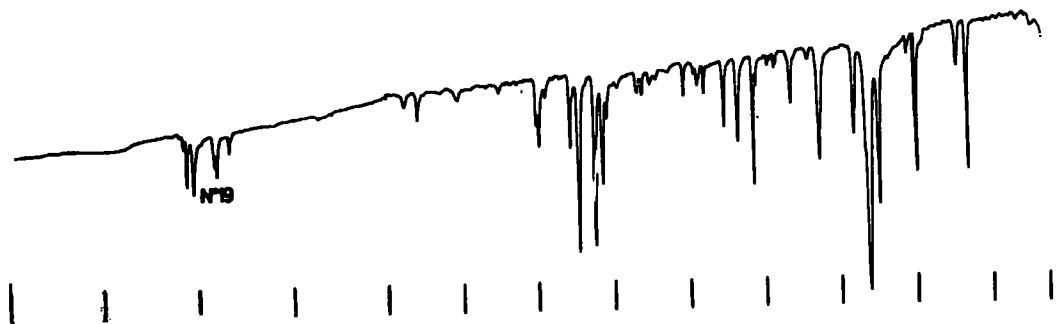
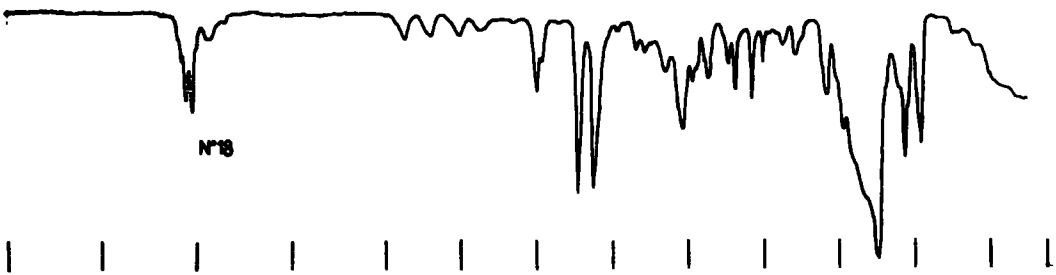
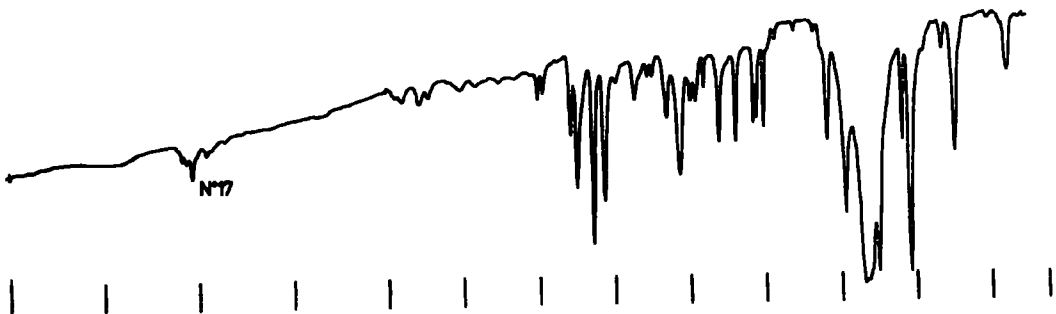
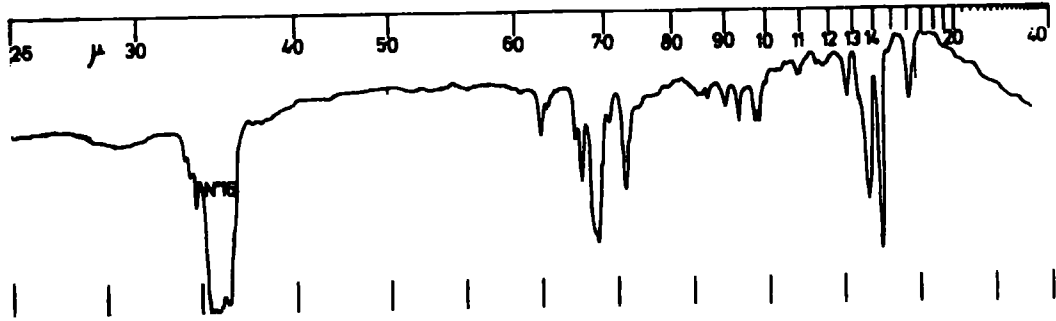
C: 50% Pure CCl₄/50% saturated soln. of BPP in CCl₄

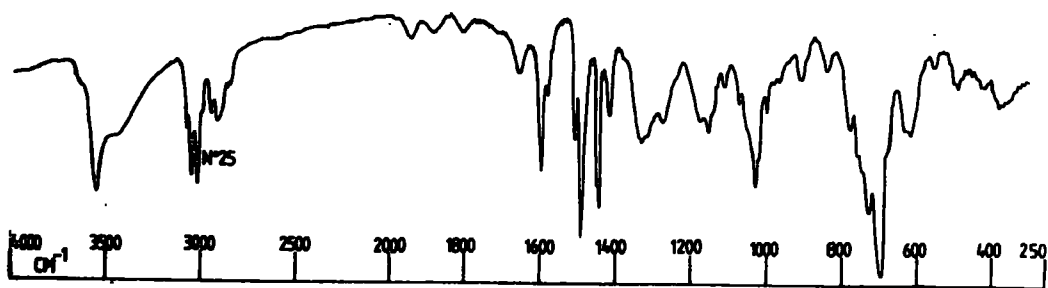
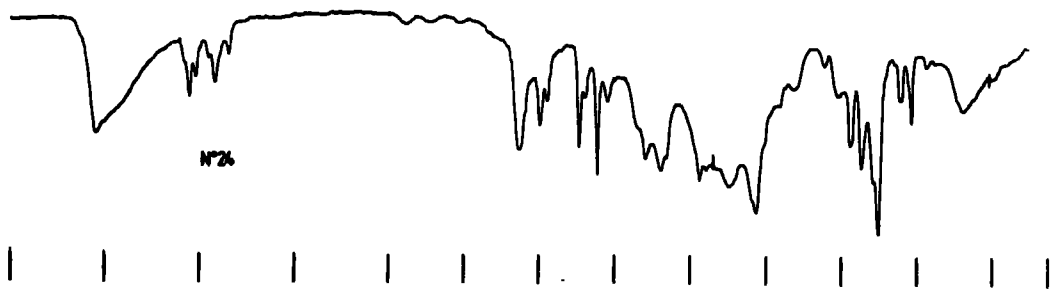
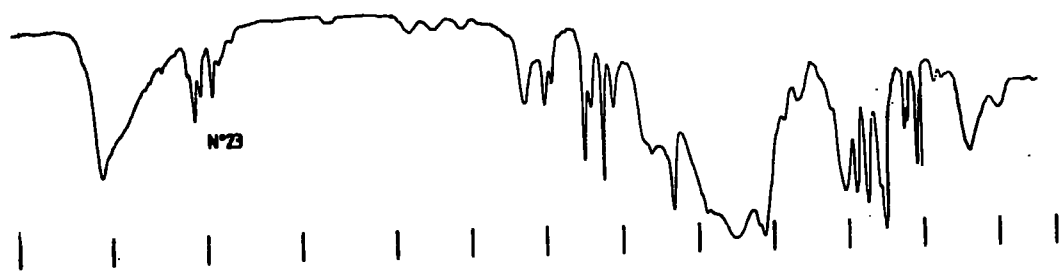
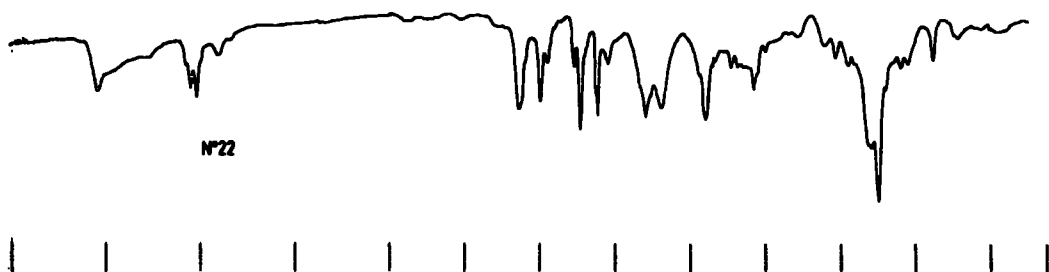
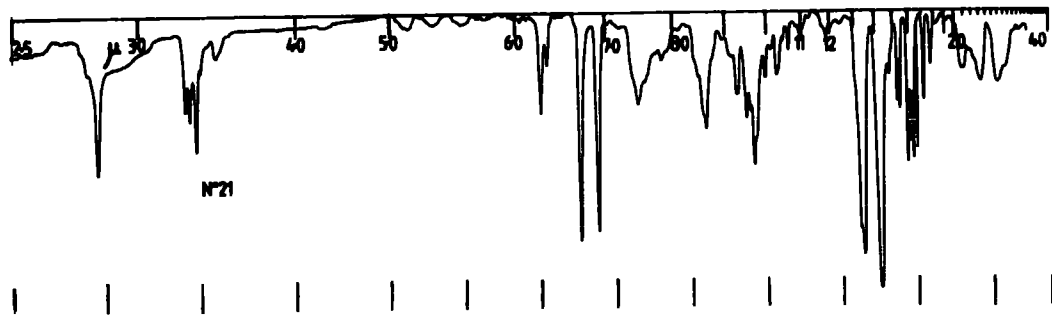
D: saturated solution of BPP in CCl₄



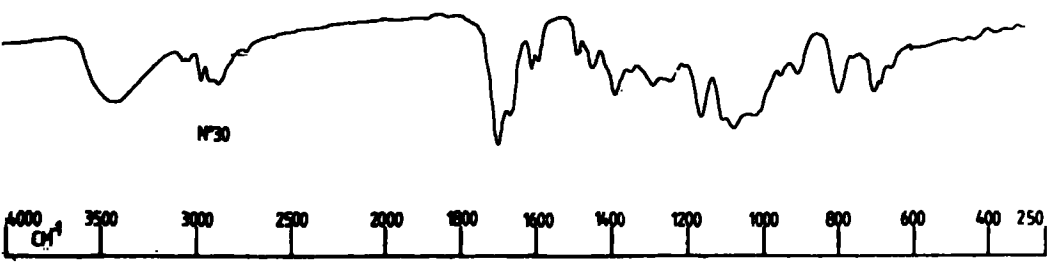
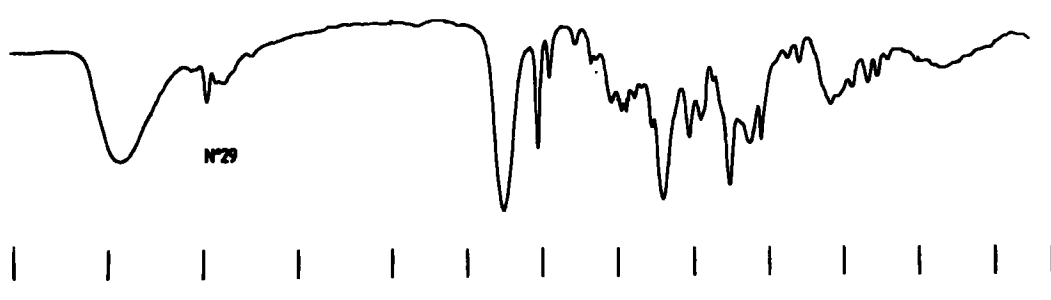
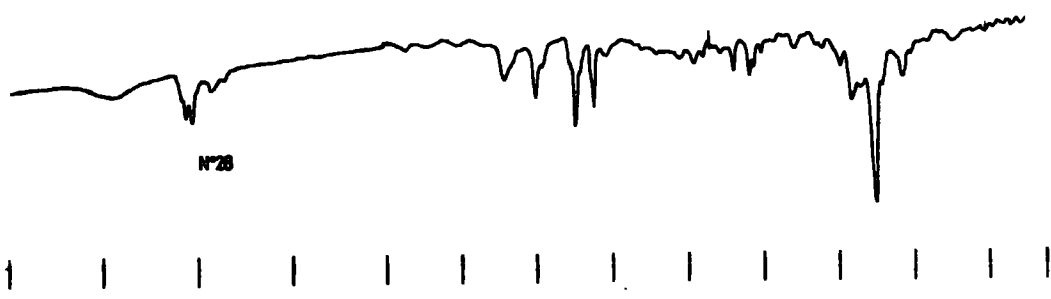
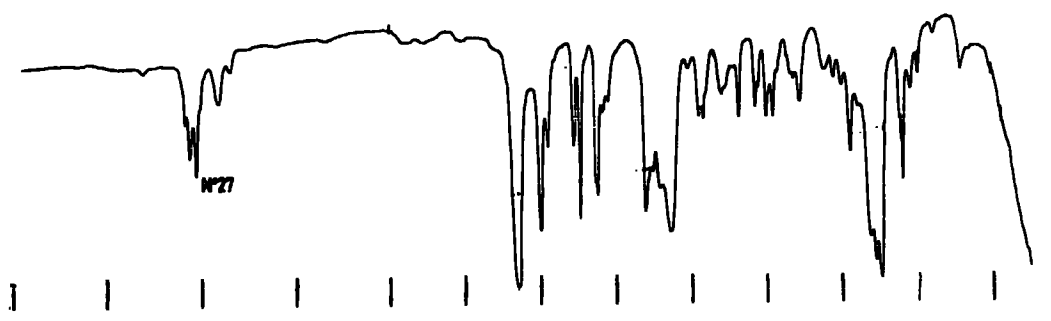
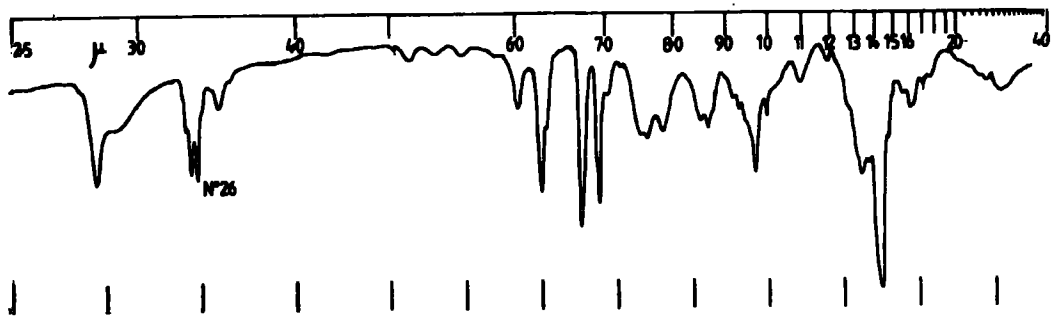








4000 3500 3000 2500 2000 1800 1600 1400 1200 1000 800 600 400 250
cm⁻¹



25 30 40 50 60 70 80 90 10 11 12 13 14 15 16 20 40



| | | | | | | | | | | | | | | | | | | | | |



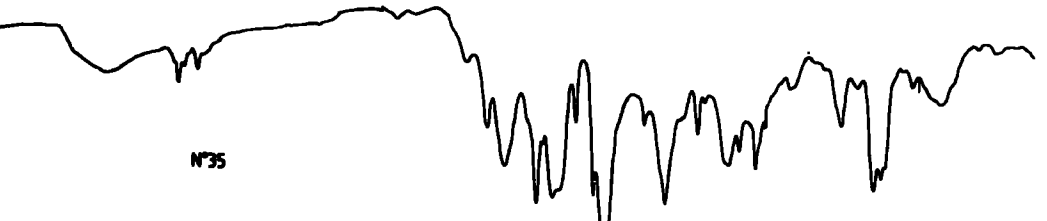
| | | | | | | | | | | | | | | | | | | | | |



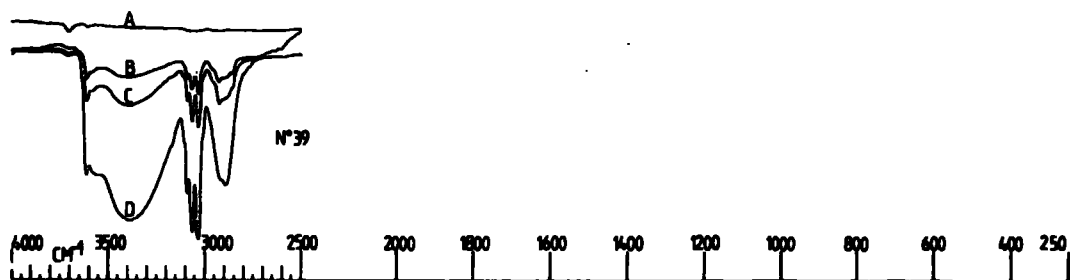
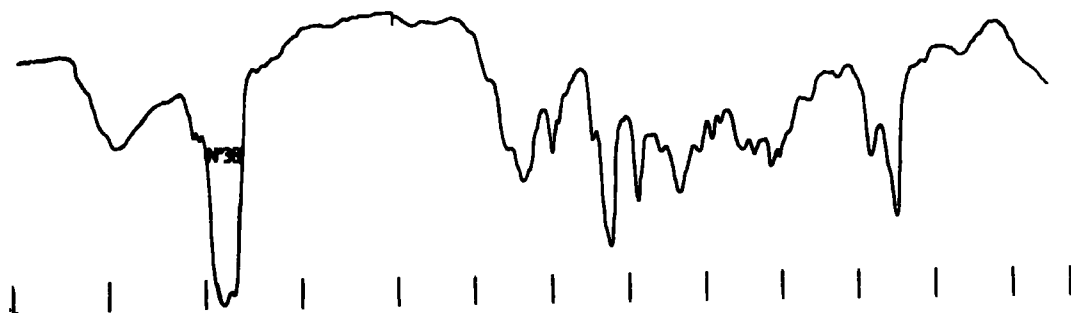
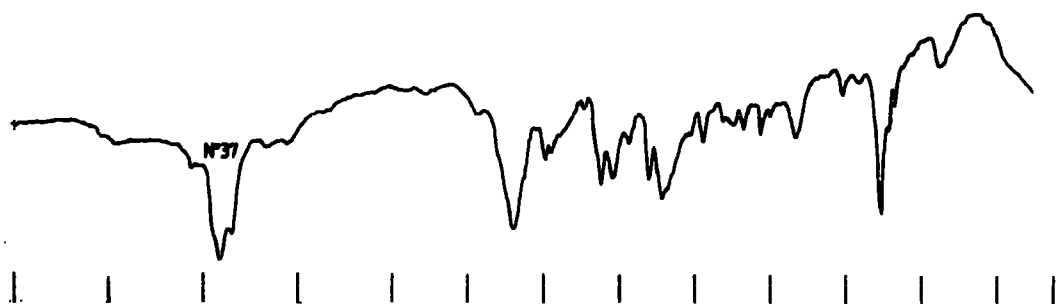
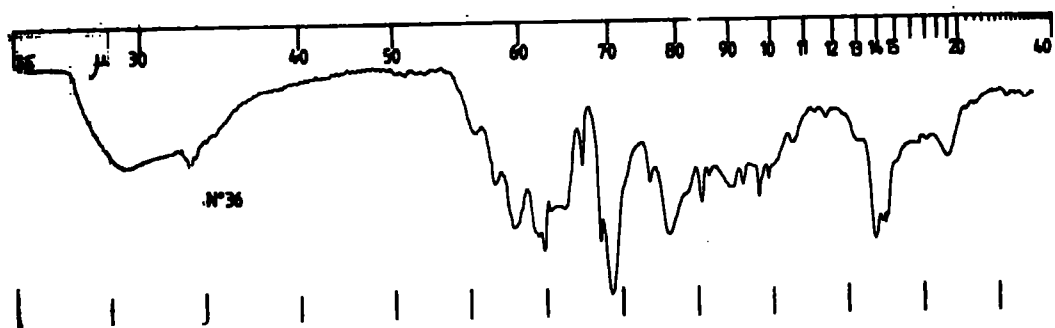
| | | | | | | | | | | | | | | | | | | | | |



| | | | | | | | | | | | | | | | | | | | | |



4000 3500 3000 2500 2000 1800 1600 1400 1200 1000 800 600 400 250
cm⁻¹



APPENDIX C

The Board of Studies in Chemistry requires that each postgraduate research thesis contain an appendix listing

- (a) all research colloquia, research seminars and lectures (by external speakers) arranged by the Department of Chemistry since 1 October 1976; and (b) all research conferences attended by the writer of the thesis, during the period when the research for the thesis was carried out.

1. Research Colloquia, Seminars and Lectures

1.1. 1976-77

a) University of Durham Chemistry Colloquia

Wednesday, 20th October

Professor J.B. Hyne (University of Calgary), "New Research on an Old Element - Sulphur".

Wednesday, 10th November

Dr. J.S. Ogden (Southampton University), "The Characterization of High Temperature Species by Matrix Isolation".

Wednesday, 17th November

Dr. B.E.F. Fender (University of Oxford), "Familiar but Remarkable Inorganic Solids".

Wednesday, 24th November

Dr. M.I. Page (Huddersfield Polytechnic), "Large and Small Rate Enhancements of Intramolecular Catalysed Reactions".

Wednesday, 8th December

Professor A.J. Leadbetter (University of Exeter), "Liquid Crystals".

Wednesday, 26th January

Dr. A. Davis (ERDR), "The Weathering of Polymeric Materials".

Wednesday, 2nd February

Dr. M. Falk, (NRC Canada), "Structural Deductions from the Vibrational Spectrum of Water in Condensed Phases".

Wednesday, 9th February

Professor R.O.C. Norman (University of York), "Radical Cations; Intermediates in Organic Reactions".

Wednesday, 23rd February

Dr. G. Harris (University of St. Andrews), "Halogen Adducts of Phosphines and Arsines".

Friday, 25th February

Professor H.T. Dieck (Frankfurt University), "Diazadienes - New Powerful Low-Valent Metal Ligands".

Wednesday, 2nd March

Dr. F. Hibbert (Birkbeck College, London), "Fast Reaction Studies of Slow Proton Transfers Involving Nitrogen and Oxygen Acids".

Friday, 4th March

Dr. G. Brink (Rhodes University, R.S.A.), "Dielectric Studies of Hydrogen Bonding in Alcohols".

Wednesday, 9th March

Dr. I.O. Sutherland (Sheffield University), "The Stevens' Rearrangement Orbital Symmetry and Radical Pairs".

Friday, 18th March

Professor Hans Bock (Frankfurt University), "Photoelectron Spectra and Molecular Properties: A Vademecum for the Chemist".

Wednesday, 30th March

Dr. J.R. MacCallum (University of St. Andrews), "Photooxidation of Polymers".

Wednesday, 20th April

Dr. D.M.J. Lilley (G.D. Searle, Research Div.), "Tails of Chromatin Structure - Progress towards a Working Model".

Wednesday, 27th April

Dr. M.P. Stevens (University of Hartford), "Photocycloaddition Polymerisation".

Wednesday, 4th May

Dr. G.C. Tabisz (University of Manitoba), "Collision Induced Light Scattering by Compressed Molecular Gases".

Wednesday, 11th May

Dr. R.E. Banks (UMIST), "The Reaction of Hexafluoropropene with Heterocyclic N-Oxides".

Wednesday, 18th May

Dr. J. Atwood (University of Alabama), "Novel Solution Behaviour of Anionic Organoaluminium Compounds: the Formation of Liquid Clathrates".

Wednesday, 25th May

Professor M.M. Kreevoy (University of Minnesota), "The Dynamics of Proton Transfer in Solution".

Wednesday, 1st June

Dr. J. McCleverty (University of Sheffield), "Consequences of Deprivation and Overcrowding on the Chemistry of Molybdenum and Tungsten".

Wednesday, 6th July

Professor J. Passmore (University of Brunswick), "Adducts Between Group V Pentahalides and a Postscript on S_7I^+ ".

b) Durham University Chemical Society

Tuesday, 19th October

Dr. J.A. Salthouse (University of Manchester), "Chemistry and Energy".

Tuesday, 26th October

Dr. R.E. Richards (University of Oxford), "NMR Measurements on Intact Biological Tissue".

Tuesday, 2nd November

Dr. B. Sutcliffe (University of York), "The Chemical Bond as a Figment of the Imagination".

Tuesday, 16th November

Mr. R. Ficken (Rohm & Haas), "The Graduate in Industry".

Tuesday, 30th November

Dr. R.J. Donovan (University of Edinburgh), "The Chemistry of the Atmosphere".

Tuesday, 18th January

Professor I. Fells (University of Newcastle), "Energy Storage: the Chemists' Contribution to the Problem".

Tuesday, 8th February

Dr. M.J. Cleare (Johnson Matthey Research Centre), "Platinum Group Metal Compounds as Anti-Cancer Agents".

Tuesday, 1st March

Professor J.A.S. Smith (Q.E. College, London), "Double Resonance".

Tuesday, 8th March

Professor C. Eabom (University of Sussex), "Structure and Reactivity".

1.2. 1977-78

a) University of Durham Chemistry Colloquia

Tuesday, 27th September

Dr. T.J. Broxton (La Trobe University, Australia), "Interaction of Aryldiazonium Salts and Arylazoalkyl Ethers in Basic Alcoholic Solvents".

Wednesday, 19th October

Dr. B. Heyn (University of Jena, D.D.R.), " σ -Organo-Molybdenum Complexes as Alkene Polymerisation Catalysts".

Thursday, 27th October

Professor R.A. Filler (Illinois Inst. of Technology, U.S.A.), "Reactions of Organic Compounds with Xenon Fluorides".

Wednesday, 2nd November

Dr. N. Boden (University of Leeds), "NMR Spin-Echo Experiments for Studying Structure and Dynamical Properties of Materials Containing Interacting Spin- $\frac{1}{2}$ Pairs".

Wednesday, 9th November

Dr. A.R. Butler (University of St. Andrews), "Why I lost Faith in Linear Free Energy Relationships".

Wednesday, 7th December

Dr. P.A. Madden (University of Cambridge), "Raman Studies of Molecular Motions in Liquids".

Wednesday, 14th December

Dr. R.O. Gould (University of Edinburgh), "Crystallography to the Rescue in Ruthenium Chemistry".

Wednesday, 25th January

Dr. G. Richards (University of Oxford), "Quantum Pharmacology".

Wednesday, 1st February

Professor K.J. Ivin (Queen University, Belfast), "The Olefin Metathesis Reaction: Mechanism of Ring-Opening Polymerisation of Cycloalkenes".

Friday, 3rd February

Dr. A. Hartog (Free University, Amsterdam, Holland), "Surprising Recent Studies in Organo-Magnesium Chemistry".

Wednesday, 22nd February

Professor J.D. Birchall (Mond Division, I.C.I. Ltd.), "Silicon in the Biosphere".

Wednesday, 1st March

Dr. A. Williams (University of Kent), "Acyl Group Transfer Reactions".

Friday, 3rd March

Dr. G. van Koten (University of Amsterdam, Holland), "Structure and Reactivity of Arylcopper Cluster Compounds".

Wednesday, 22nd March

Professor H. Vahrenkamp (University of Freiburg, Germany), "Metal-Metal Bonds in Organometallic Complexes".

Wednesday, 19th April

Dr. M. Barber (UMIST), "Secondary Ion Mass Spectra of Surfaces and Absorbed Species".

Tuesday, 16th May

Dr. P. Ferguson (C.N.R.S., Grenoble), "Surface Plasma Waves and Absorbed Species on Metals".

Thursday, 18th May

Professor M. Gordon (University of Essex), "Three Critical Points in Polymer Science".

Monday, 22nd May

Professor D. Tuck (University of Windsor, Ontario), "Electrochemical Synthesis of Inorganic and Organometallic Compounds".

Wednesday - Thursday 24th, 25th May

Professor P. von R. Schleyer (University of Erlangen, Nürnberg),

- I. "Planar Tetra-coordinate Methanes, Perpendicular Ethylenes, and Planar Allenes".
- II. "Aromaticity in Three Dimensions".
- III. "Non-classical Carbocations".

Wednesday, 21st June

Dr. S.K. Tyrlik (Academy of Science, Warsaw), "Dimethylglyoxime-cobalt Complexes - Catalytic Black Boxes".

Friday, 23rd June

Professor W.B. Pearson (University of Florida), "Diode Laser Spectroscopy at 16 μm ".

Friday, 30th June

Professor G. Mateescu (Case Western Reserve University),
"A Concerted Spectroscopy Approach to the Characterization of Ions and Ion Pairs: Facts, Plans, and Dreams".

b) Durham University Chemical Society

Thursday, 13th October

Dr. J.C. Young, Mr. A.J.S. Williams (University of Aberystwyth),
"Experiments and Considerations Touching Colour".

Thursday, 20th October

Dr. R.L. Williams (Metropolitan Police Forensic Science Dept.),
"Science and Crime".

Thursday, 3rd November

Dr. G.W. Gray (University of Hull), "Liquid Crystals - Their Origins and Applications".

Thursday, 24th November

Mr. G. Russell (Alcan), "Designing for Social Acceptability".

Thursday, 1st December

Dr. B.F.G. Johnson (University of Cambridge), "Chemistry of Binary Metal Carbonyls".

Thursday, 2nd February

Professor R.A. Raphael (University of Cambridge), "Bizarre Reactions of Acetylenic Compounds".

Thursday, 16th February

Professor G.W.A. Fowles (University of Reading), "Home Winemaking".

Thursday, 2nd March

Professor M.W. Roberts (University of Bradford), "The Discovery of Molecular Events at Solid Surfaces".

Thursday, 9th March

Professor H. Suschitzky (University of Salford), "Fruitful Fissions of Benzofuroxans".

Thursday, 4th May

Professor J. Chatt (University of Sussex), "Reactions of Coordinated Dinitrogen".

Tuesday, 9th May

Professor G.A. Olah (Case Western Reserve University, Cleveland, Ohio), "Electrophilic Reactions of Hydrocarbons".

2. Conferences Attended

Photopolymerization and Polymer Photodegradation, Southampton, September 1976.

1st Polymer Surfaces Symposium, Durham, March 1977.

REFERENCES

1. G. Oster and N.-L. Yang, Chem. Rev., 1968, 68, 125.
2. N.G. Gaylord, Tech. Papers, Reg. Conf. Soc. Plast. Eng., Mid-Hudson Sect., Nov. 6-7, 1967, 32.
3. J. Blyth and A.W. Hofmann, Annalen, 1845, 53, 289.
4. J. Hutchinson and A. Ledwith, Adv. Polymer Sci., 1974, 14, 49.
5. H.-G. Heine, H.-J. Rosenkranz and H. Radolph, Angew. Chem. Int. Edit., 1972, 11, 974.
6. A. Ledwith, Intern. Conf. on Exciplexes, London, Ontario, May 1974.
7. M.R. Sandner and C.L. Osborn, Tetrahedron Lett., 1974, 415.
8. C.H. Carder, Paint and Varnish Production, 1974 (August), 19.
9. G. Irick, J. Appl. Polymer Sci., 1972, 16, 2387.
10. R. Nilsson and D.R. Kearns, Photochem. Photobiol., 1974, 19, 181.
11. M. Tsuda, J. Polymer Sci., Part A-1, 1969, 7, 259.
12. A.D. Hay, D.A. Bolon, K.R. Leimer and R.F. Clark, J. Polymer Sci., Part B, 1970, 8, 97.
13. J.L.R. Williams, Tech. Papers, Reg. Conf. Soc. Plast. Eng., Mid-Hudson Sect., Nov. 6-7, 123.
14. L.M. Minsk, J.G. Smith, W.P. van Deuson and J.F. Wright, J. Appl. Polymer Sci., 1959, 2, 302.
15. E.M. Robertson, W.P. van Deuson and L.M. Minsk, J. Appl. Polymer Sci., 1959, 2, 308.
16. R.C. Schultz, L. Rohe and H. Adler, Eur. Polymer Journal (Bratislava Supplement), 1969, 5, 309.
17. H. Tanaka, M. Tsuda and H. Nakanishi, J. Polymer Sci., Part A-1, Polymer Chem., 1972, 10, 1729.
18. H. Jacobs and R. Steele, J. Appl. Polymer Sci., 1960, 3, 239.

19. F.C. De Schryver, N. Boens and G. Smets, J. Polymer Sci., Part A-1, Polymer Chem., 1972, 10, 1687 and refs. cited therein.
20. F.C. De Schryver et al., J. Polymer Sci., Polymer Chem., 1975, 13, 215.
21. J.B. Birks, 'Photophysics of Aromatic Molecules', Interscience, New York, 1970, pp. 320, 369.
22. F.C. De Schryver, L. Anand, G. Smets and J. Switten, J. Polymer Sci., Part B, Polymer Letters, 1971, 9, 777.
23. F.C. De Schryver and G.A. Delzenne, Ger. Offen. 2,212,427/1972.
24. F.C. De Schryver, W.J. Feast and G. Smets, J. Polymer Sci., Part A-1, Polymer Chem., 1970, 8, 1939.
25. F.C. De Schryver in 'Microsymposium on Photochemical Processes in Polymer Chemistry', Leuven, Belgium, June 1972.
26. D.J. Andrews and W.J. Feast, J. Polymer Sci., Polymer Chem., 1976, 14, 319.
27. D.J. Andrews and W.J. Feast, ibid., 331.
28. L.H. Leenders, E. Schouteden and F.C. De Schryver, J. Org. Chem., 1973, 38, 957.
29. D.R. Arnold, Adv. Photochem., 1968, 6, 301.
30. H. Leblanc, Doctoral Thesis, Leuven, Belgium, 1972.
31. R.C. Schultz and H.H. Bossler, Umschau Wiss. Tech., 1971, 71, 673.
32. H.H. Bossler and R.C. Schultz, Macromol. Chem., 1972, 158, 113.
33. L. Horner and A. Christmann, Angew. Chem., 1963, 75, 707.
34. R.C. Schultz, Pure & Appl. Chem., 1973, 34, 305.
35. N. Kardush and M.P. Stevens, J. Polymer Sci., Part A-1, 1972, 1093.
36. Y. Musa and M.P. Stevens, ibid., 10, 319.
37. D. Bryce-Smith and M.A. Hems, Tetrahedron Letters, 1966, 1895.
38. J.S. Bradshaw, Tetrahedron Letters, 1966, 2039.
39. U.S.P. 3,366,642/1968.
40. F.C. De Schryver, Tran Van Thien, S. Toppet and G. Smets, J. Polymer Sci., Polymer Chem. Edit., 1975, 13, 227.

41. M. Iguchi, H. Nakanishi and M. Hasegawa, J. Polymer Sci., Part A-1, 1968, 6, 1055.
42. M. Hasegawa, Y. Suzuki, F. Suzuki and H. Nakanishi, J. Polymer Sci., Part A-1, 1969, 7, 743.
43. M. Hasegawa and Y. Suzuki, Polymer Letters, 1967, 5, 813.
44. M. Hasegawa Y. Suzuki and T. Tamaki, Bull. Chem. Soc. Japan, 1970, 43, 2020.
45. M.J. Helm and F.B. Zienty, J. Polymer Sci., Part A-1, 1972, 10, 1311.
46. W.J. Feast, Research Proposal to European Research Office, U.S. Army, March 1974, p. 2.
47. J.G. Calvert and J.N. Pitts, Jr., 'Photochemistry', J. Wiley, New York, 1966, p. 252.
48. K. Bredereck, Th. Foerster and H.G. Oesterlin, Chem. Abs., 1963, 58, 75146.
49. C. Walling and M.J. Gibian, J. Amer. Chem. Soc., 1965, 87, 3361.
50. A. Padwa, Tetrahedron Letters, 1964, 3465.
51. N.J. Turro, J.C. Dalton, K. Dawes, G. Farrington, R. Hautala, D. Morton, M. Niemczyk and N. Shore, Accounts Chem. Res., 1972, 5, 92.
52. N.J. Turro, 'Molecular Photochemistry', W.A. Benjamin, Inc., New York, 1965.
53. R.O. Kan, 'Organic Photochemistry', McGraw-Hill, New York, 1966.
54. R.B. Cundall and A. Gilbert, 'Photochemistry', T. Nelson & Sons Ltd., London, 1970.
55. J.S. Swenton, J. Chem. Educ., 1969, 46, 217.
56. G. Ciamician and P. Silber, Ber., 1900, 33, 2911.
57. W.D. Cohen, Rec. Trav. Chim., 1920, 39, 243.
58. L.F. Fieser, 'Organic Experiments', D.C. Heath & Co., Boston, 1964, Ch. 40.
59. D.E. Pearson and P.D. Thiemann, J. Polymer Sci., Part A-1, Polymer Chem., 1970, 8, 2103.

60. J. Higgins, A.H. Johannes, J.F. Jones, R. Schultz, D.A. McCombs and C.S. Menon, J. Polymer Sci., Part A-1, Polymer Chem., 1970, 8, 1987.
61. D.A. McCombs, C.S. Menon and J. Higgins, J. Polymer Sci., Part A-1, Polymer Chem., 1971, 9, 1261.
62. F.C. De Schryver, T. Tran Van and G. Smets, J. Polymer Sci., Part B, Polymer Chem., 1971, 9, 425.
63. M. Gomberg and W.E. Bachmann, J. Amer. Chem. Soc., 1927, 49, 236.
64. D.J. Andrews, Ph.D. Thesis, Durham University, 1973.
65. Qualitative measurements by the author confirmed Andrews' observation.
66. S.A. Weiner, J. Amer. Chem. Soc., 1971, 93, 424.
67. A. Schönberg, 'Preparative Organic Photochemistry', Springer-Verlag, Berlin, 1968 (Ch. 22).
68. W.E. Bachmann, J. Amer. Chem. Soc., 1933, 55, 391 and references therein.
69. Reference 67, Ch. 20.
70. A. Schönberg and A. Mustafa, J. Chem. Soc., 1944, 67.
71. M.R. Kegelman and E.V. Brown, J. Amer. Chem. Soc., 1953, 75, 4649.
72. C. Weizmann, E. Bergmann and Y. Hirshberg, J. Amer. Chem. Soc., 1938, 60, 1530.
73. W.L. Bencze, C.A. Burckhardt and W.L. Yost, J. Org. Chem., 1962, 27, 2865.
74. F. Bergmann and Y. Hirshberg, J. Amer. Chem. Soc., 1943, 65, 1429.
75. J.N. Pitts, Jr., R.L. Letsinger, R.P. Taylor, J.M. Patterson, G. Recktenwald and R.B. Martin, J. Amer. Chem. Soc., 1959, 81, 1068.
76. G.S. Hammond, W.P. Baker and W.M. Moore, J. Amer. Chem. Soc., 1961, 83, 2795.
77. A. Beckett and G. Porter, Trans. Farad. Soc., 1963, 59, 2038.
78. J.N. Pitts, Jr., and J.K.S. Wan in 'Chemistry of the Carbonyl Group', Ed. S. Patai, Interscience, New York, 1966, Ch. 14.
79. G.S. Hammond and P.A. Leermakers, J. Amer. Chem. Soc., 1962, 84, 207.

80. H. Mauser and V. Bihl, Z. Naturforsch (B), 1967, 22, 1077.
81. N. Filipescu and F.L. Minn, J. Amer. Chem. Soc., 1968, 90, 1544.
82. N. Filipescu, L.M. Kindley and F.L. Minn, J. Org. Chem., 1971, 36, 861.
83. J. Saltiel, H.C. Curtis and B. Jones, Molec. Photochem., 1970, 2, 331.
84. J.A. Bell and H. Linschitz, J. Amer. Chem. Soc., 1963, 85, 528.
85. A.V. Buettner and J. Dedinas, J. Phys. Chem., 1971, 75, 187.
86. J. Saltiel, H. Curtis, L. Metts, J.M. Miley, J. Winterle and M. Wrighton, J. Amer. Chem. Soc., 1970, 92, 410.
87. D.I. Schuster and D.F. Brizzolara, J. Amer. Chem. Soc., 1970, 92, 4357.
88. D.I. Schuster, T.M. Weil and A.M. Halpern, J. Amer. Chem. Soc., 94, 8248.
89. G.L. Closs and L.E. Closs, J. Amer. Chem. Soc., 1964, 91, 4550.
90. M. Nicolas and R. Pailland, Ind. Chim. Belge, 1971, T36, 117.
91. J.S. Bradshaw, Chem. Comm., 1973, 504.
92. G. Gotzmer, Jr., K.F. Muller and M.J. Cziesla, J. Org. Chem., 1973, 38, 2964.
93. M.J. Gibian, Tetrahedron Letters, 1967, 5331.
94. F.L. Minn, C.L. Trichilo, C.R. Hurt and N. Filipescu, J. Amer. Chem. Soc., 1970, 92, 3600.
95. W.L. Bencke, C.A. Burckhart and W.L. Yost, J. Org. Chem., 1962, 27, 2865.
96. H.L.J. Backstrom and R.J.V. Nicklasson, Acta Chem. Scandin., 1966, 20, 2617.
97. W.M. Moore and M.D. Ketchum, J. Phys. Chem., 1964, 86, 214.
98. N. Filipescu, J.P. Pinlon and F.L. Minn, Chem. Comm., 1970, 1413.
99. J. Dedinas and T.H. Reagan, J. Phys. Chem., 1972, 76, 3926.
100. B.D. Challand, Can. J. Chem., 1969, 47, 687.
101. M.B. Ledger and G. Porter, Faraday Trans., I, 1972, 68, 539.
102. P.S. Eugel and B.M. Monroe, Adv. Photochem., 8, 253.

103. G.O. Schenck, G. Kotzenburg and E. Roselius, Tetrahedron Letters, 1970, 5185.
104. R.S. Davison and F.A. Younis, Chem. Comm., 1969, 826.
105. V. Franzen, Justus Liebigs, Ann. Chem., 1960, 633, 1.
106. G. Porter and G. Suppan, Pure Appl. Chem., 1964, 9, 499.
107. F. Wilkinson. Adv. Photochem., 1964, 3, 241.
108. G. Porter and G. Suppan, Proc. Chem. Soc., 1964, 191.
109. E.J. Baum, J.K.S. Wan and J.N. Pitts, Jr., J. Amer. Chem. Soc., 1966, 88, 2652 and references cited therein.
110. S.G. Cohen, M.D. Saltzman and J.B. Guttenplan, Tetrahedron Letters, 1969, 4321.
111. N.C. Yang and C. Rivas, J. Amer. Chem. Soc., 1961, 83, 2213.
112. F.D. Lewis, Tetrahedron Letters, 1970, 1373.
113. M.Y. Moss, Diss. Abstr., 1968, B29, 944.
114. N.D. Heindel, E.W. Sarrer and M.A. Pfau, Tetrahedron Letters, 1968, 3579.
115. D.E. Pearson and M.Y. Moss, ibid., 1967, 3791.
116. F.A. Lamb and B.M. Vittimberga, J. Org. Chem., 1973, 38, 3520.
117. P. Suppan, Ber. Bunseng. Phys. Chem., 1968, 72, 321.
118. D.C. Neckers and D.P. Colebrander, Tetrahedron Letters, 1968, 5045.
119. E. Paternò and G. Chieffi, Gazz. Chim. Ital., 1909, II, 39, 415.
120. E. Bergmann and S.-I. Fujise, Annalen, 1930, 483, 65.
121. M. Barnard and N.C. Yang, Proc. Chem. Soc., 1958, 302.
122. Reference 67, Ch. 21.
123. See for example:
- a) A.A. Berlin, J. Macromol. Sci.-Chem., 1971, A5, 1187.
- b) I. Schopov et al., Macromol. Chem., 1975, 176, 511 and ibid., 1976, 177, 1653.

123. c) D. Braun et al., Macromol. Chem., 1976, 177, 1373, 1387, 1673, 2221.
124. G. Ciamician and P. Silber, Ber., 1915, I, 193.
125. G. Ciamician and P. Silber, Atti Accad. Lincei, 3 Jan 1886.
126. D. Loew, 'Die Chemischen Energie der lebenden Zelle', (1899).
127. G. Ciamician and P. Silber, Atti Accad. Lincei, 1901, 10, 92.
128. G. Ciamician and P. Silber, Gazz. Chim. Ital., 1904, 34(II), 129.
129. A. Gardeur, Chemisches Centralblatt, 1897, II, 662.
130. E. Paternò and G. Chieffi, Gazz. Chim. Ital., 1910, 40(II), 321.
131. E. Paternò and G. Forli-Forti, Gazz. Chim. Ital., 1910, 40(II), 332.
132. E. Paternò, Gazz. Chim. Ital., 1914, 44(II), 99.
133. E. Paternò, ibid., 1914, 44, 151.
134. E. Paternò, ibid., 1914, 44(II), 463.
135. G. Ciamician and P. Silber, Ber., 1915, I, 193.
136. E. Paternò, Gazz. Chim. Ital., 1909, 39(II), 213.
137. McKenzie and Wren, J. Chem. Soc., 97, 481.
138. A. Ledwith, P.J. Russell and L.H. Sutcliffe, J. Chem. Soc., Perkin (II), 1972, 1925.
139. J.M. Wilson, J. Chem. Soc., 1951, 2297.
140. Dictionary of Organic Compounds, Eynes & Spottinswoode (Publishers) Ltd., London, 1965.
141. Bergmann and Engel, Zeit. Phys. Chem., 1930, B8, 133.
142. R. Wegler, Ber., 1934, 67B, 35.
143. G. Richard, Chem. Zentr., 1934, 1051, 3744.
144. F. Koelsch, J. Amer. Chem. Soc., 1931, 53, 1147.
145. J.S.W. Boyle, A. McKenzie and W. Mitchell, Ber., 1937, 70B, 2153.
146. A. Banchetti, Ann. Chim. Appl., 1941, 31, 430.
147. A. Banchetti, Gazz. Chim. Ital., 1942, 72, 74.
148. O. Polansky, E. Schinzel and F. Wessely, Monatsch., 1956, 87, 24.

149. P.J. Hamrick, Jr., and C.R. Houser, J. Amer. Chem. Soc., 1959, 81, 2096.
150. S.H. Metzger, Jr., Diss. Abs., 1963, 23, 2702.
151. H. Zincke, Ber., 6, 119 and 9, 31.
152. Thiele and Balhorn, Ber., 37, 1467.
153. R.C. Huston and T.E. Friedmann, J. Amer. Chem. Soc., 1916, 38, 2531.
154. Japanese Patent 6,902,708/1969.
155. E. Profft, G. Drechsler and H. Oberender, Wiss. Z. Tech. Hochsch. Chem. Leuna-Merseburg 2,1959/60, 259.
156. A.B. Galun, A. Kaluszyner and E.D. Bergmann, J. Org. Chem., 1962, 27, 2372.
157. A. Vogel, 'Practical Organic Chemistry', 3rd Edition, Longman, London 1974.
158. R.T. Morrison and R.N. Boyd, 'Organic Chemistry', 3rd Edition, Allyn and Bacon Inc., Boston, 1974.
159. R. Grinter and S.F. Mason, Trans. Faraday Soc., 1964, 60, 889.
160. Beilstein's Handbuch der Organischen Chemie.
161. D.S. Tarbell and J.C. Petropoulos, J. Amer. Chem. Soc., 1952, 74, 244.
162. C.K. Steinhardt, private communication to the author in Fieser & Fieser, 'Reagents for Organic Synthesis', John Wiley & Sons, Inc., 1967, p. 584.
163. R.S. Matthews, private communication.
164. 'Handbook of Chemistry and Physics', 46th Edition, The Chemical Rubber Co., Ohio, 1965.
165. D.A. McCombs, C.S. Menon and J. Higgins, J. Polymer. Sci., Part A-1 Polymer Chem., 1971, 9, 1799.
166. A. Gandini and P.H. Plesch, Proc. Chem. Soc., 1964 (April), 113.
167. G. Ciamician and P. Silber, Rend. Acc. Lincei, 1905, I, 265.
168. L. Mascarelli, Gazz. Chim. Ital., 1906, II, 670.
169. G. Ciamician and P. Silber, Rend. Acc. Lincei, 1909, I, 216.

170. G. Ciamician and P. Silber, ibid., 1914, XXIII, 112.
171. G.R. De Mare, J.R. Fox, M. Termonia and B. Tshibangila, European Polymer J., 1975, 12, 119.
172. R. Raff, J.L. Cook and B.V. Etting, J. Polymer Sci., Part A 3(10), 1965, 3511.
173. U.S.P. 3,419,462 (1968).
174. U.S.P. 3,414,466 (1968).
175. T.B. Fomina, N.V. Artem'eva, Yu. N. Sazarov and M.M. Koton, Dokl. Akad. Nauk. SSSR, 1970, 139(4), 838.
176. Kenji Yokota and Yoshio Ishii, Kogyo Kagaku Zasshi, 1963, 66, 130.
177. U.S.P. 3,509,097/1970.
178. Bilow, Norman and Rosenberg, J. Polymer Sci., Part A-1, 1969, 7(9), 2689.
179. J.F. Jackson and S.J. Gill, J. Polymer Sci., Part A-2, 1967, 5(4), 663.
180. U.S.P. 3,442,861 (1969).
181. Leznoff, Clifford and Wong, Can. J. Chem., 1973, 51(22), 3756.
182. A. Schönberg and A. Mustafa, J. Amer. Chem. Soc., 1955, 77, 5755.
183. J. Kagan, Tetrahedron Letters, 1966, 49, 6097.
184. K.F. Cohen, J.T. Pinhey and R.J. Smith, Tetrahedron Letters, 1968, 4729.
185. D.A. Harrison, R.N. Schwartz and J. Kagan, J. Amer. Chem. Soc., 1972, 92, 5793.
186. P. Longia, C.R. Acad. Sci., 1962, 255, 865.
187. M. Stockburger, Z. Phys. Chem. (Frankfurt am Main), 1962, 31, 350.
188. G.R. De Mare, P. Goldfinger, G. Huybrechts, E. Jonas and M. Toth, Ber. Bunsenges Phys. Chem., 1969, 73, 867.
189. N.C. Yang, Photochem. Photobiol., 1968, 7, 767.
190. N.C. Yang, J.I. Cohen and A. Shani, J. Amer. Chem. Soc., 1968, 90, 3264.

191. See for example:
- a) J.M. Hollas, E. Gregorek and L. Goodman, J. Chem. Phys., 1968, 49, 1745.
 - b) F. Dörn, Z. Elektrochem., 1957, 61, 950.
 - c) J.R. Majer, S.-A. M.A. Naman and J.C. Robb, Trans. Faraday Soc., 1969, 65, 1846.
 - d) K. Inuzuka and T. Yokota, Bull. Chem. Soc. Japan, 1965, 38, 1055.
 - e) K. Kimura and S. Nagakura, Theor. Chem. Acta, 1965, 3, 164.
 - f) R. Shimada and L. Goodman, J. Chem. Phys., 1965, 43, 2027.
 - g) O.A. Ponomarev, Izv. Vyssh. Ucheb. Zared. Fiz., 1966, 9(4), 21.
192. F. Almsy, J. Chem. Phys., 1933, 30, 528, 634, 713.
193. G.R. De Mare, M.C. Fontaine and P. Goldfinger, J. Org. Chem., 1968, 33, 2528.
194. a) M. de Hemptinne, J. Phys. Radium, 1929, 9, 357.
b) C.R. Acad. Sci., 1928, 186, 1295.
195. F.E. Blacet and D. Vanselow, Abstracts, 131th National Meeting of the Amer. Chem. Soc., Miami Beach, Florida, 1957.
196. M. Berger, I.L. Goldblatt and C. Steel, J. Amer. Chem. Soc., 1973 95, 1717.
197. J.S. Bradshaw, R.D. Knudsen and W.W. Parish, J. Chem. Soc., Chem. Comm., 1972, 1321.
198. a) M. Cocivera and A.M. Trozzolo, J. Amer. Chem. Soc., 1970, 92, 1772.
b) G.L. Closs and D.R. Paulson, ibid., 7229.
199. F.D. Lewis, R.T. Lauterbach, H.-G. Heine, W. Hartmann and H. Rudolph, J. Amer. Chem. Soc., 1975, 97, 1519.
200. Kornis and De Mayo, Can. J. Chem., 1964, 42, 2822.
201. J.N. Pitts et al., J. Amer. Chem. Soc., 1969, 91, 2461.
202. Heine, Hartmann, Kory, Maggar, Hoyle, McVery and Lewis, J. Org. Chem., 1974, 39, 691.

203. Bunbury and Chuang, Can. Chem. J., 1969, 47, 2045.
204. a) H. Suida, Monatsch., 1912, 33, 1173.
b) C.J. Kothari and H.E. Watson, J. Indian Inst. Sci., 1931, A(II), 14.
c) H.L.J. Blackstrom, Medd. Vetenskapsakad. Nobelinst., 1927, 6, No. 15.
d) M. Trautz, Eders Jahrbuch, 1909, 57, 421.
205. a) P. Preiswerk and H. Erlenmeyer, Helv. Chim. Acta, 1934, 17, 329.
b) E. Schauenstein and M. Stampfer, Ber., 1944, 77B, 19.
206. G. Büchi, C.G. Büchi, C.G. Inman and E.S. Lipinsky, J. Amer. Chem. Soc., 1954, 76, 4327.
207. L.L. Muller and J. Hamer, '1,2-Cycloaddition Reactions', Interscience, New York, 1967.
208. D.R. Arnold, R.L. Hinman and A.H. Glick, Tetrahedron Letters, 1964, 1425.
209. N.J. Turro, P. Wriede, J.C. Dalton, D.R. Arnold and A.H. Glick, J. Amer. Chem. Soc., 1967, 89, 3950.
210. R.A. Caldwell, G.W. Sovocool and R.P. Gajewski, J. Amer. Chem. Soc., 1973, 95, 2549.
211. Y. Shigemitsu, Y. Katsuhara and Y. Odaira, Tetrahedron Letters, 1971, 2887.
212. S. Farid and S.E. Scheiler, J. Chem. Soc. (D), Chem. Comm., 1973, 296.
213. S.R. Kurowsky and H. Morrison, J. Amer. Chem. Soc., 1972, 94, 507.
214. J. Saltiel, R.M. Coates and W.G. Dauben, J. Amer. Chem. Soc., 1966, 88, 2745.
215. N. Nozaki, I. Otani, R. Noyari and M. Kawanisi, Tetrahedron, 1968, 24, 2183.
216. C. DeBoer, Tetrahedron Letters, 1971, 4977.
217. S. Farid, J.C. Doty and J.L.R. Williams, J. Chem. Soc. (D), 1972, 711.
218. D. Bryce-Smith and A. Gilbert, Proc. Chem. Soc., 1964, 87;
Tetrahedron Letters, 1964, 3471.

219. J.F. Harris, Jr., J. Org. Chem., 1965, 30, 2182.
220. J.D. Margerum, J.N. Pitts, Jr., J.G. Rutgers and S. Searles, J. Amer. Chem. Soc., 1959, 81, 1549.
221. H. Gotthardt, R. Steinmetz and G.S. Hammond, Chem. Comm., 1967, 480.
222. G.O. Schenk, W. Hartmann and R. Steinmetz, Chem. Ber., 1963, 96, 498.
223. G.S. Hammond and N.J. Turro, Science, 1963, 142, 1451.
224. D. Gagnaire and E. Payo, Subiza, Bull. Soc. Chim. France, 1963, 11, 2623.
225. M. Ogata, H. Watanabe and H. Kano, Tetrahedron Letters, 1967, 533.
226. J. Leitich, Tetrahedron Letters, 1967, 1937.
227. S. Toki and H. Sakurai, Tetrahedron Letters, 1967, 4119.
228. C. Rivas and E. Payo, J. Org. Chem., 1967, 32, 2918.
229. S.H. Schroeter and C.M. Orlando, Jr., J. Org. Chem., 1969, 34, 1181.
230. J. Dedinas, J. Phys. Chem., 1971, 75, 181.
231. D.I. Schuster, T.M. Weil and M.A. Halpern, J. Amer. Chem. Soc., 1972, 94, 8248.
232. R.J. Gritter, in 'The Chemistry of the Ether Linkage', S. Patai Ed., Interscience, New York, 1967, Ch. 9.
233. U.S.P. 2,995,572/1961.
234. Dutch Patent 5,404,598/1964.
235. French Patent 1,391,493/1965.
236. E.J. Cook and B.F. Landrum, J. Heterocyclic Chem., 1965, 5, 327.
237. J.D. LaZerte and R.J. Koshar, J. Amer. Chem. Soc., 1955, 77, 910.
238. H. Muramatsu and K. Inukai, J. Org. Chem., 1962, 27, 1572.
239. E.R. Bissell and D.B. Fields, J. Org. Chem., 1964, 29, 249.
240. J.F. Harris, Jr., and D.D. Coffman, J. Amer. Chem. Soc., 1962, 84, 1553.
241. U.S.P. 2,594,272/1952.
242. R.N. Haszeldine and F. Nyman, J. Chem. Soc., 1959, 1084.

243. J.L. Zollinger, J.R. Throckmorton, S.T. Ting, R.A. Mitsch and
D.E. Elrick, J. Macromol. Sci. (Chem.), 1969, 3, 1443.
244. J.D. LaZerte, L.J. Hall, T.S. Reid and G.H. Smith, J. Amer. Chem. Soc.,
1953, 75, 4525.
245. A.N. Bell, R. Fields, R.N. Haszeldine and I. Kumadaki, J. Chem. Soc.,
Chem. Comm., 1975, 866.

