



Durham E-Theses

An investigation of the surface and bulk nitration of cellulose

Short, Robert D.

How to cite:

Short, Robert D. (1986) *An investigation of the surface and bulk nitration of cellulose*, Durham theses, Durham University. Available at Durham E-Theses Online: <http://etheses.dur.ac.uk/7098/>

Use policy

The full-text may be used and/or reproduced, and given to third parties in any format or medium, without prior permission or charge, for personal research or study, educational, or not-for-profit purposes provided that:

- a full bibliographic reference is made to the original source
- a [link](#) is made to the metadata record in Durham E-Theses
- the full-text is not changed in any way

The full-text must not be sold in any format or medium without the formal permission of the copyright holders.

Please consult the [full Durham E-Theses policy](#) for further details.

The copyright of this thesis rests with the author.
No quotation from it should be published without
his prior written consent and information derived
from it should be acknowledged.

A thesis entitled

AN INVESTIGATION OF THE SURFACE AND BULK NITRATION OF
CELLULOSE

by

ROBERT D. SHORT, B.Sc. (Hons)

A candidate for the Degree of Doctor of Philosophy

Van Mildert College,
Durham

October 1987



23 JUN 1988

Therig
1987/SHO

ACKNOWLEDGEMENTS

Firstly, I would like to thank my supervisor, Dr. Hugh Munro, without whose help and enthusiasm this thesis would not have been possible.

Thanks also to Drs. Tom Lewis and Frank Baker for their advice and criticism and to the Ministry of Defence for the grant which made this work possible.

For their help with the N.M.R. studies I would like to thank Dr. Ray Matthews and Mr. John Banks (solution state) and also Mr. Tim Pritchard (solid state).

Thanks to: Mr. Ron Hardy for his help with X-ray diffraction measurements; Mrs. Molley Cocks and Mr. Bob Coult for help with the elemental analysis; Dr. Graham Russell for running the SEMs; Mr. John Parkinson, who sadly is no longer with us, for running the TGAs; Dr. Ken Hutchinson for his time in connection with the Raman work and Mr. Ian Mc.Briar for help with the plasma work.

Thanks also Dr. Andy Fowler for early guidance.

For their friendship, help and advice thanks to the members of the ESCA lab (past and present). These people are Hugh, Jeff, Clare, Clive, Ian, Graham, Richard and Susan.

Tanks all so too Peter Hoare four poof reeding a large proportion off this thesis.

My only regret of the last three years is that I didn't beat Dr. Hardy Chan at Tennis as regularly as I'd have liked.

ABSTRACT

Modern analytical techniques have been employed to investigate the nitration reaction of cellulose.

The nitronium ion, NO_2^+ , is shown to be the important nitrating species of cellulose in the nitrating media employed. In mixes of high nitronium ion concentration, nitration at the cellulose surface is observed, by ESCA, to be extremely rapid, while in mixes of low nitronium ion concentration it is observed to be comparatively slow.

It is shown that the degree of substitution (DOS) achieved at the fibre surface is equilibrium controlled. However, it is also shown that cellulose morphology plays an important role in determining the final bulk DOS achieved by nitration.

The surface and bulk nitration of cellulose in dichloromethane/nitric acid mixes has been investigated by a variety of techniques. ^{13}C solution state nmr has been employed to monitor the partial DOS established at the individual sites of the anhydroglucose residues. The substitution distribution patterns observed for materials in the DOS range 1.8 → 2.4 are very dependent on the nitrating media employed. Further, the differences in the substitution distribution pattern are reflected in the $d(101)$ mean interchain spacing. A possible explanation for these differences is forwarded.

The plasma etching of cellulose nitrate has been investigated as a function of DOS. The influence of sulphate ester residues on etch rate is also considered.

MEMORANDUM

The work outlined in this thesis is wholly original except where referenced, and this thesis contains material which forms part or whole of the following publication.

- 1 H.S. Munro, A.H.K Fowler and R.D. Short, Polym. Commn., 1986, 27, 251
- 2 H.S. Munro and R.D. Short in 'Wood and Cellulosics', Eds. J.F. Kennedy, G.O. Phillips and P.A. Williams, Ellis-Horwood, 1987.

CONTENTS

	Page No.
Acknowledgements	ii
Abstract	iii
Memorandum	iv
Contents	v

CHAPTER ONE - A REVIEW OF THE 'OLDER' LITERATURE PERTAINING TO THE NITRATION OF CELLULOSE

Part I - The Nitration Of Cellulose

1.1.1 Introduction	2
1.1.2 The Nitration of Cellulose with Nitric Acid	5
1.1.3 The Nitration of Cellulose with Mixed Acids	14
1.1.4 Other Nitrating Mixes	27

Part II - Cellulose Structure

1.2.1 Introduction	29
1.2.2 The Cellulose Molecule	29
1.2.3 Cellulose Sources	30
1.2.4 The Crystal Structure of Cellulose	37
1.2.5 The Crystallinity of Celluloses	42
1.2.6 The Structure of Cellulose Nitrate	48

CHAPTER TWO - A REVIEW OF THE MORE RECENT LITERATURE PERTAINING TO THE NITRATION OF CELLULOSE AND PRELIMINARY INVESTIGATIONS TO ESTABLISH THE ACCURACY OF TECHNIQUES EMPLOYED IN THIS THESIS

2.1.1 Introduction	54
2.1.2 The Application of NMR to Cellulose Nitrates	55
2.1.3 The Application of ESCA to Cellulose Nitrates	56

2.1.4 Nitration - AN ESCA / NMR Investigation	67
2.1.5 Denitration AN ESCA / NMR Investigation	69
2.1.6 Surface DOS, Sulphate Ester Formation and Accessibility	73
2.1.7 Discrepancies in the Surface DOS	77
2.2 Experimental	80
Results and Discussion	
2.3.1 An Investigation of Experimental Accuracy	83
2.3.2 An Investigation of X-ray Stability	89
2.3.3 A Study of Techniques Employed for Bulk DOS Analysis	95
2.3.4 A Study of the Quenching and Stabilization Procedures	96
2.3.5 A Comparison of Surface and Bulk DOS	100
2.3.6 Cellophane as an Alternative Cellulose Source	102
2.3.7 Summary	114

CHAPTER THREE - A STUDY OF NITRATION IN MIXED ACIDS.

	118
3.1 Introduction	119
3.2 Experimental	122
Results and Discussion	
3.3.1 The Nitrating Species in Mixed Acids	123
3.3.2 Nitration in Mixed Acids where the Nitronium Ion is not Spectroscopically Observable	135
3.3.3 The Effect of Fibre Structure on Bulk DOS	146
3.3.4 Nitration with Phosphoric / Nitric Acid Mixes	154
3.3.5 Summary	155

CHAPTER FOUR - A RE-INVESTIGATION OF THE LOW TEMPERATURE	
NITRATION	159
4.1 Introduction	160
4.2 Experimental	166
4.3.1 A Preliminary Investigation of the Quenching Procedure	167
4.3.2 A Study of 'Low Temperature Denitration'	168
4.3.3 A Raman Temperature Study of Mixed Acids	171
4.3.4 Low Temperature Nitration	178
4.3.5 The Bulk Nitration of Cellulose with Technical Mixed Acids Maintained at Low Temperature	179
4.3.6 Surface Nitration in Mixed Acids at Low Temperature	189
4.3.7 Summary	196
 CHAPTER FIVE - THE NITRATION OF CELLULOSE WITH NITRONIUM	
ION	198
5.1 Introduction	200
5.2 Experimental	202
Results and Discussion	
5.3.1 Surface Contamination	203
5.3.2 A Study of Surface and Bulk DOS	205
5.3.3 The Kinetics of Nitration	211
5.3.4 X-Ray Stability	215
5.3.5 Summary	217
 CHAPTER SIX - A STUDY OF SURFACE AND BULK NITRATION IN	
NITRIC ACID (ALONE) AND IN DICHLOROMETHANE / NITRIC ACID	
MIXES.	219
6.1 Introduction	220

6.2	Experimental	222
Results and Discussion		
6.3.1	Nitration with Nitric Acid / Water Mixes	223
6.3.2	The Nitrating Species in Fuming Nitric Acid	224
6.3.3	The Nitrating Species in Aqueous Nitric Acid	228
6.3.4	Nitration in Nitric Acid / Dichloromethane Mixes: The Nitrating Species	231
6.3.5	Surface and Bulk DOS with Acid Mix Composition (Dichloromethane / Nitric Acid Mixes)	234
6.3.6	The Re-Use of a Dichloromethane / Nitric Acid Mix	239
6.3.7	A NMR - X-ray Diffraction Study of the Bulk Chemistry of Dichloromethane / Nitric Acid Prepared Cellulose Nitrates	241
6.3.8	A Study of Thermal and X-ray Stability	251
6.3.9	Summary	255
6.3.10	Overall Summary of Work Contained in Chapters 2-6	256

**CHAPTER SEVEN - A PRELIMINARY INVESTIGATION OF THE PLASMA
ETCHING OF CELLULOSE NITRATE**

		262
7.1	Introduction	263
7.2	Experimental	265
7.3.1	The Etch Rate of H_2SO_4/HNO_3 Prepared Cellulose Nitrates in O_2 Plasmas	266
7.3.2	The Etch Rate of a CH_2Cl_2/HNO_3 Prepared Cellulose Nitrate in O_2 Plasma	268
7.3.3	A Surface Study of Etched Materials	270

7.3.4 Cellulose Nitrate in an Ar Plasma	274
7.3.5 Cellulose Nitrate in a H ₂ Plasma	276
7.3.6 Etch Rate with DOS	276
7.3.7 Summary	278
Appendix One	280
Appendix Two	296

CHAPTER ONE - A REVIEW OF THE 'OLDER' LITERATURE
PERTAINING TO THE NITRATION OF CELLULOSE



1.1.1 Introduction

Cellulose nitrate is the oldest cellulose derivative, first prepared in 1833 when cellulose fibres in the form of sawdust, linen and paper were treated with nitric acid¹. It is also the most important inorganic ester of cellulose having a range of industrial applications in diverse areas such as :-

- (a) lacquer coatings for protection and decoration (automobile refinish, wooden furniture)²,
 - (b) inks (photogravure ink coatings)²,
 - (c) plastics and films e.g. celluloid, the first synthetic plastic²,
 - (d) plasticizers and films²,
 - (e) the nuclear industry e.g. in personnel nuclear-radiation monitoring devices or as track detectors^{3,4},
 - (f) micro-electronics as a resist material⁵,
- and perhaps most important,
- (g) the munitions industry where it is employed in explosives and propellents. Generally cellulose nitrate is combined with nitroglycerin to form double based explosives/propellents⁶.

This is not an exhaustive list but it does give some idea of the variety of uses to which cellulose nitrate can be put. The commercial value of cellulose nitrate has led to considerable interest in its chemical and physical properties.

In many of the above listed applications the usefulness of a cellulose nitrate is determined by its

degree of substitution (DOS)* and it is the conditions under which cellulose nitrates are prepared that ultimately control DOS as well as the other important properties of nitrated materials which include:- degree of polymerization, fibre structure, homogeneity of nitration, stability and the extent to which undesirable side reactions proceed. A complete understanding of the nitration mechanism is yet to be established despite the considerable attention nitration has received. The purpose of this part of the chapter is to provide an overview of the 'classical' literature (pre 1978) pertaining to the preparation of cellulose nitrate. The nitration of cellulose is, in nearly all cases, heterogeneous and it is therefore important to understand how fibre structure influences the diffusion of the nitrating medium in and out of the cellulose. In the second part of this chapter the structure of the cellulose and cellulose nitrate fibres is considered.

* DOS. There are three hydroxyl groups per glucose unit that can be potentially nitrated (the hydroxyl group is replaced by a nitrate functionality i.e. substituted). Therefore complete nitration at every glucose unit ring will give a trisubstituted cellulose nitrate (i.e. a DOS of 3). However, it is more typical that only a few glucose rings are trisubstituted, whilst others are disubstituted, monosubstituted or unsubstituted. Hence it is more common that the DOS of a cellulose fibre is of an intermediate value, say 2.1 i.e. the averaged DOS of all the glucose units. This idea is expanded in section 1.2.1.

Over the last six years (1978 - 1984) the application of new spectroscopic techniques in particular ^{13}C nmr and ESCA to cellulose nitrate chemistry has led to a rapid expansion in the understanding of the nitration mechanism and it is this work that forms the subject matter of Chapter 2.

1.1.2 The Nitration of Cellulose with Nitric Acid

Introduction

The earliest attempts to prepare cellulose nitrate were by the immersion of cellulose in liquid nitric acid - water mixes, however this resulted in an unstable and highly degraded material⁶. To improve the quality of the nitrated product chemists have put considerable effort into developing an understanding of the nitration process. In 1882 Vieille first reported the relationship that exists between the concentration of the nitrating acid and the nitrogen content (DOS) of the cellulose^{7,8,9}, see Table 1.1.

Table 1 Nitrogen content by weight with acid mix employed.

% HNO ₃	77.3	80.8	83.5	87.0	89.6	92.1	95.1
% N	6.85	8.07	8.78	10.33	11.53	12.23	12.68

The relationship that exists between the % nitrogen and DOS is presented graphically in the appendix. The highest nitrogen content obtained was 12.7 %, well short of the theoretical maximum 14.14 %^{*}. Below 77 % HNO₃ partial dissolution of the cellulose occurred⁺. Vieille suggested that this was the result of hydrolysis or oxidation of the cellulose nitrate product by the dilute nitric acid.

* 14.14 % N corresponds to a D.O.S. of 3, i.e. complete esterification of all available hydroxyls in the cellulose polymer.

+ Knecht and others¹⁰ claim to have successfully nitrated cellulose in less concentrated mixes e.g. 65 % HNO₃. However, examination of the product by X-ray diffraction has shown these materials to be an addition product and not a true esterification product.

The fastest rate of nitration reported was in the most concentrated mix i.e. 95.1 % nitric acid. Since Vieille's pioneering work there has been much effort put into developing a good understanding of the nitration mechanism of cellulose with nitric acid. In this section an overview of the relevant 'open' literature is presented.

The Nitration of Cellulose in Nitric Acid Vapour

Baker and Bateman¹ in 1930 established that cellulose fibres will nitrate in the presence of nitric acid vapour. The use of vapour phase nitration has never been commercially pursued because nitration has been shown to be uneven throughout the fibre and extraordinarily slow². Kinetic studies have failed to establish a clear relationship between the rate of nitration and the vapour pressure of the nitric acid. However, there is strong evidence to link the initial rate of nitration to the amount of nitric acid absorbed but unreacted.

The vapour phase denitration of high DOS cellulose nitrates with nitric acid - water mixes has also been reported³.

Solution Phase Nitration

Liquid nitric acid is a very unsatisfactory nitrating medium and is never used commercially. The product of nitration is always swollen and, in 77-85 % nitric acid-water mixes, dissolves in the nitrating mix (to be recovered by precipitation in water). In the work

reported by Vieille³ a 95.1 % acid gave a product of 12.7 % nitrogen. Crawford¹ has reported preparing a cellulose nitrate of 13.8 % nitrogen employing anhydrous nitric acid however, 13.8 % is still well short of complete reaction.

The failure to prepare higher % nitrogen products with nitric acid has been explained by Miles in terms of 'accessibility' of the cellulose fibre to the nitrating mix². Miles maintains that the difficulty encountered when attempting to completely nitrate cellulose with nitric acid is due to gelatinisation of the cellulose fibres by the acid hydrate ($\text{HNO}_3 \cdot \text{H}_2\text{O}$) which prevents free diffusion of the acid (HNO_3) into the fibre. Chedin⁴ has shown that although anhydrous nitric acid can only nitrate cellulose linters to 13.2 % nitrogen, higher percentages (up to 13.8 %) can be achieved by repeated treatment with this acid if the product is dissolved in acetone, precipitated by adding water and dried between nitrations. However 13.7-13.8 % nitrogen, although approaching the theoretical maximum of 14.14 % nitrogen, appears to be the limiting extent to which nitration with nitric acid (alone) will proceed.

Addition of salts, potassium, sodium and ammonium nitrates to anhydrous nitric acid have been shown to reduce gelatinisation during nitration⁵. However, the addition of these salts to anhydrous nitric acid does not dramatically raise the % nitrogen of the nitrated product. The typical % nitrogen reported for nitrations in salt/acid mixes is in the region of 13.0 - 13.8 % .

With the addition of water to anhydrous nitric acid the nitrating ability of the acid mix can be seen to decrease, Table 1.1. Mixes of high water content have been shown only to nitrate cellulose feebly or not at all⁶. Acid mixes in the composition range of 77 to 83.5% nitric will nitrate cellulose from 7.5 to 10.0 % nitrogen, although the product of nitration is entirely dissolved in the acid mix. The 85 % nitric acid mix is of particular interest; Miles and Wilson^{1,2} studying the rate of nitration and denitration of cellulose / nitrocelluloses over a range of acid - water mixes have reported that the highest rate of nitration is observed in an 85 % nitric acid (contrary to Vieille's work^{3,4}) as well as the fastest rate of denitration. Further, there is a prolific uptake of nitric acid by the fibre from the acid-water mix, i.e. the nitric acid is absorbed by the fibre but does not react. This acid can be recovered by washing the product of nitration with plenty of water. The importance of these results is considered in the following sections.

Absorption of Nitric Acid by Cellulose.

Whether nitrating cellulose fibres with nitric acid vapour or nitric acid liquids, adsorption of nitric acid onto the cellulose surface has been shown to precede nitration^{6,7}. Further, adsorption not only precedes nitration but continues during nitration and after the nitration is complete. Absorption of nitric acid in the cellulose fibre is also well established to proceed before, during and after nitration^{6,7}. Acid that is

absorbed, but does not chemically react with the cellulose and can be recovered by washing with water (or to a lesser extent by squeezing).

Concomitantly, with acid absorption, both cellulose and cellulose nitrate will absorb water from a nitric acid-water mix (although not to the same extent)^{5,6}.

Miles and Wilson¹⁰ have shown that the residual nitric acid which remains in a cellulose nitrate after nitration has ended is present in two forms. Firstly as spent acid of the same composition as the mix acid after removal of the product* and secondly, as nitric acid diluted to a lesser extent by water also absorbed from the mix. The spent acid can be removed by squeezing the product of nitration in rollers. The absorbed nitric acid can not be removed mechanically.

Miles⁶ has determined the mass of nitric acid absorbed per 1 gram of cellulose for a range of aqueous nitric acid mixes; that is, the weight of acid absorbed but unreacted after nitration is complete. The mass of residual acid absorbed was observed to be at a maximum in an 85 % nitric acid-water mix.

* Since nitric acid is consumed during the nitration, the composition of the acid mix will not be the same after nitration as before. Further, water is a by-product of esterification and so the removal of one nitric acid molecule by reaction produces one water molecule. Spent acids are much richer in water than the starting acid. It is usual to use at least a 30:1 excess by weight of acid to cellulose to prevent dilution becoming a serious problem.

As reported above, when nitrating cellulose fibres in nitric acid vapour no intelligible relationship has been found between the nitric acid vapour pressure and the rate of nitration. There does however appear to be a second order dependence between the weight of acid absorbed by the fibres and the initial rate of nitration.

Understanding the absorption processes is very important if an attempt is to be made to describe the mechanism of nitration in nitric acid. Such an understanding could be of great practical utility since nitric acid is expensive and it is clearly advantageous to recover as much unreacted acid after nitration as possible.

Denitration of Cellulose Nitrate

Whereas the nitration of aromatics is irreversible, the esterification of alcohols is generally a reversible reaction. Berl and Klays⁵ were the first workers to report the denitration of cellulose nitrate. Although Berl and Klays employed mixed acids (sulphuric and nitric acid) the reversibility of nitration in aqueous nitric acid mixes is well established⁶.

A high DOS cellulose nitrate immersed in a nitric acid-water mix unable to support such a DOS material will denitrate; e.g. a 2.6 DOS cellulose nitrate placed in an acid mix capable only of nitrating cellulose up to a DOS of 2 will denitrate to a DOS of around 2. Generally the denitrated cellulose will still be of a higher DOS than would be expected if the nitrating capacity of the mix is considered (i.e. in the above example the cellulose nitrate would denitrate to about 2.1). Further, the rate

of denitration has been shown to be appreciably slower than that of nitration⁶.

Miles and Wilson^{1,2} have monitored the denitration of 13.1 % nitrogen nitro-ramie (ramie is a highly crystalline cellulose fibre) in a range of acid water mixes. Denitration was observed to be most rapid in 80-85 % nitric acid- water mixes. Further, the mass of absorbed but unreacted nitric acid was determined to be greatest for the 85 % nitric acid-water mix. Chedin^{1,4} has shown, by combining spectroscopic, electrochemical and vapour pressure data, that the major constituent of the 85% nitric acid-water mix is the hydrated nitric acid molecule. This species is widely accepted to be the principle denitrating agent⁶. Neither acid nor water alone have been shown to have any appreciable effect on the DOS of a cellulose nitrate⁶. The limit on this observation is that in concentrated acids, e.g sulphuric acid > 68 %, cellulose nitrate will dissolve irretrievably.

Physical Changes caused by Nitration (Swelling)

On immersion of cellulose into any nitrating media change occurs in the physical condition of the fibre⁶. This has already been alluded to when considering the effect of 100 % nitric acid on cellulose. The most familiar example of this is roughening of the fibre when nitrated in mixed acids of greater than 20 -25 % nitric acid. In other acid mixes there may be obvious swelling of the fibre, or solution as described above for aqueous nitric acid mixes (77-84 %). Miles⁶ has considered the physical changes in the fibre on nitration in aqueous

nitric acid mixes. In the 85 % nitric acid-water mix (discussed above) the preferential absorption of nitric acid is associated with a rapid swelling of the celluloses fibres. In this mix it is reported that both nitration of cellulose and denitration of nitro-ramie are extremely rapid (as discussed above).

Clearly, changes in fibre structure:- swelling, gelatinisation or solution (in extreme cases) have important implications when discussing the rate of nitration-denitration of celluloses observed in aqueous nitric acid mixes. However, in this type of experiment it may not be the true rate of nitration or denitration that is being monitored, but rather the rate of penetration of the mix throughout the fibre. This hypothesis is discussed later in this chapter and tested in chapter six.

The Nitrating Species

The nature of the nitrating species in nitric acid water mixes has yet to be unambiguously identified, although several candidates have been proposed. In his comprehensive review of 1955 Miles¹⁶ considered un-ionized nitric acid the most likely candidate responsible for nitration. The evidence supporting the involvement of the nitric acid molecule in nitration is much the same as that put forward for its involvement in mixed acids and this is reviewed in Section 1.2.2

The involvement of the nitronium ion, NO_2^+ , the accepted nitrating species in most organic nitrations^{16, 17}, Miles ruled out on the grounds that:-

(i) electrochemical and spectroscopic data show the ion is either present in low concentration in anhydrous nitric acid, or not at all after the addition of 4-5 % by weight of water to the dry acid. Lee and Millen¹⁹ have shown that at -10°C anhydrous nitric acid is 4-5 % (by weight) dissociated according to equation 1



(ii) nitration occurs in nitric acid vapour and Miles considered the existence of the nitronium ion in the acid vapour highly unlikely.

Miles⁶ proposed that the nitration equilibrium can be described by equation 2

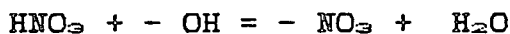

or by 3

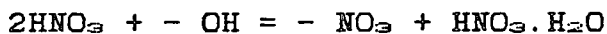

taking into account the hydration of a nitric acid molecule. These equations are still widely accepted to describe the nitration of cellulose with nitric acid^{7, 19}.

1.1.3 The Nitration of Cellulose with Mixed Acids

The addition of sulphuric acid to nitric acid facilitates the production of an appreciably less swollen and less degraded cellulose nitrate. It is thought that this is because the sulphuric acid counteracts the swelling action of the nitric acid⁷. Sulphuric-nitric acid-water mixes are employed in nearly all commercial nitrations. Almost every possible ratio of these acids with water have been investigated. This has led to nitration diagrams being drawn up. From these diagrams the expected DOS can be estimated for nitration in a particular acid mix. However, the usefulness of these diagrams has been questioned since they do not take into account the nature of the starting material, which may effect the final DOS achieved. Two such diagrams are presented in Figures 1.1 and 1.2 based on the early work of Bruley²⁰ (1895-1896) and from the later studies of Miles⁶ (1953). Figure 1.2 also details regions of acid mix composition where swelling or solution of the cellulose or product will occur.

Since sulphuric acid is cheaper than nitric it is more economical to nitrate in mixes of high sulphuric acid and low nitric acid content. The range of compositions commonly employed for nitration is described in Figure 1.2 by the technical zone (of nitration). Discussion will be limited to nitrations with mixes that are technically employed. The zone is narrow as the nitric acid composition is kept between 20-30 % and changes in DOS are effected by altering the sulphuric acid to water ratio.

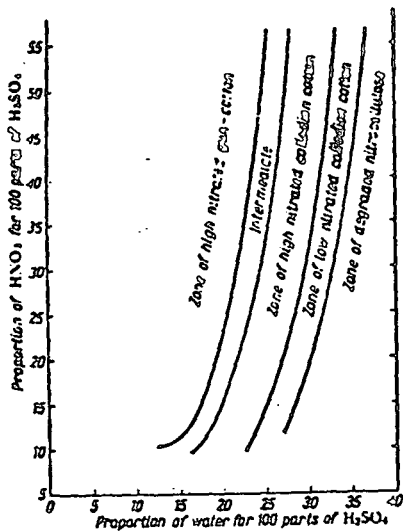

Relation between the nitrogen content of nitrocellulose and composition of mixed acids, according to Bruley

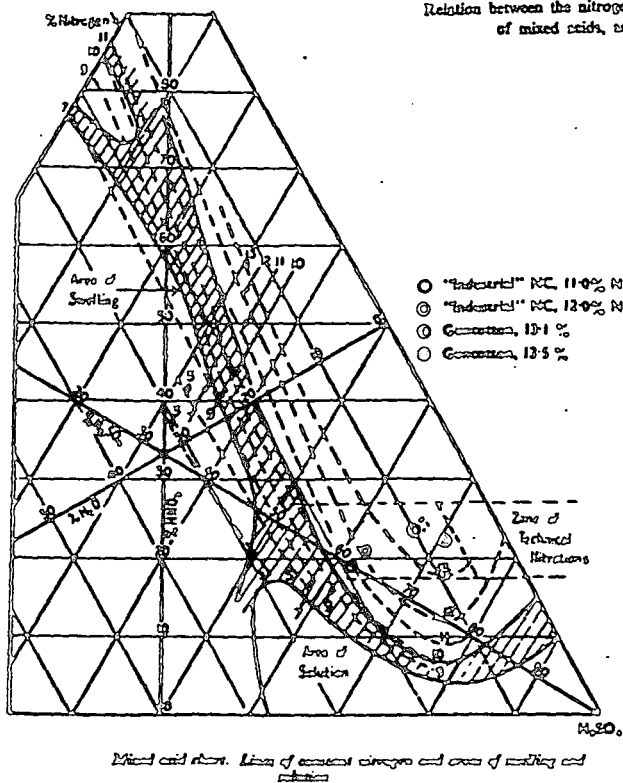

Figures 1.1 (top) and 1.2 (bottom).

Kinetics of Nitration with Mixed Acids

The reader could be easily be forgiven for being confused when looking through the great volume of literature relating to the kinetics of nitration in mixed acids. Confusion can arise because authors have tended to omit details of the mix composition, cellulose source, or to recognize that reactions, other than nitration, are also simultaneously ongoing in an acid mix.

Vieille²⁰ (1884) was probably the first to report that the rate of nitration of cotton linters is depressed by the addition of sulphuric acid to nitric acid. Lunge et al²¹ have examined in more detail the influence of the sulphuric to nitric acid ratio (of an acid mix) on the rate of reaction and have confirmed the early observation of Vieille. Typical nitration times reported by Lunge for a range of sulphuric-nitric acid ratios are presented in Table 1.2.

Table 1.2 The effect of acid mix composition on the rate of nitration

<u>ratio H₂SO₄:HNO₃</u>	<u>Maximum D.O.S. reached after</u>
1:1	0.5 hr
3:1	3 hrs
8:1	30 days

However, Spalding²² employing a 21% nitric acid, 61.5% sulphuric acid and 17.5% water mix has shown nitration to be complete within 5 minutes, see Figure 1.3

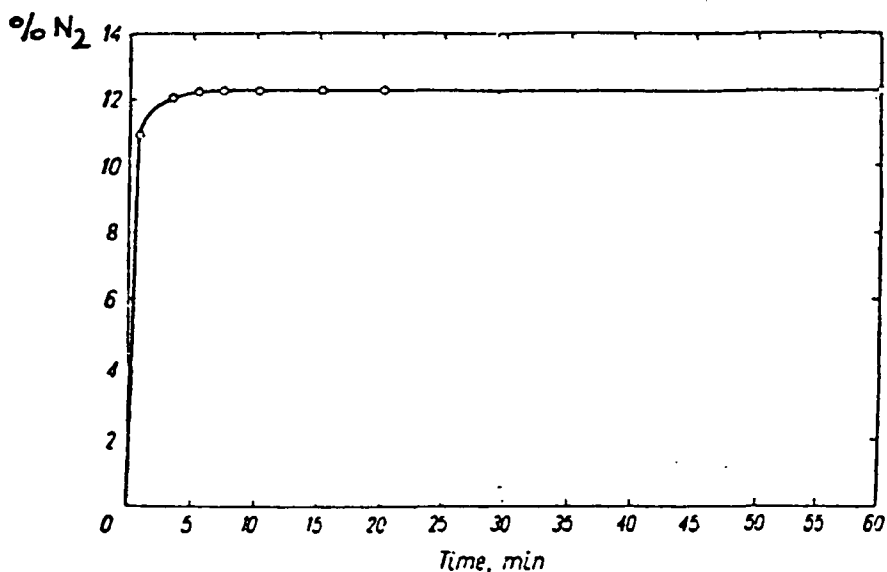

Figure 1.3 Rate of nitration according to Spalding²²

Clearly, the addition of water to a mixed acid greatly enhances the rate of nitration. Miles⁶ and Urbanski⁷ in their reviews of cellulose nitrate chemistry both came to the conclusion that the rate of nitration is ultimately controlled by the speed of diffusion of the acids into the cellulose fibre. Cellulose is a semi-crystalline polymer and it is the classical view that in the crystalline regions diffusion is either slow or incomplete.⁷ The ability of an acid mix to penetrate into the crystalline regions determines the time taken to reach 'final' DOS. Hence, acid mixes that cause swelling of the fibre can penetrate these crystalline regions much more readily. Two factors are therefore

important to consider when discussing the rate of nitration:-

(i) the penetrating or swelling ability of the acid mix,

and (ii) the fibre 'structure'.

The swelling capacities of sulphuric acid, nitric acid and other reagents on the cotton fibre are reviewed in Section 1.2.4

Jeffries et al²³ have by a variety of techniques shown that cotton linters, a natural source of cellulose, are about 70-80% crystalline whilst mercerized cotton is only about 50% crystalline. Sakurada²⁴ has measured the rate of nitration of bleached and unbleached cotton at 0°C. The rate of nitration in the less crystalline bleached cotton was considerably more rapid.

Anhydrous Mixed Acids.

It is interesting to note from Figure 1.2 that anhydrous acid mixes in the technical zone do not produce cellulose nitrates of the highest nitrogen content. Rassow and Bonge²⁵ have reported attaining the highest nitrogen content by diluting anhydrous mixes with 9-10 % water. Nitrations in anhydrous mixes are appreciably slower than in mixes where the 10% of the sulphuric acid has been replaced by water. Further, increasing the proportion of sulphuric acid in a mix reduces the stability of the product⁷. The increased instability (characterized by an accelerated rate of nitrogen loss from a cellulose nitrate with storage) is thought to be a consequence of sulphate ester formation in the cellulose.

Stabilization

Stabilization of cellulose nitrate is achieved by boiling or pressure steaming with many changes of water. The stability of the treated material is usually assessed by the Abel Heat Test⁷ or the Bergmann - Junk Test⁷

Schobein's original patent²⁶ of October 1846 instructed that the pressing of the nitrated cotton was sufficient to remove all adhering acid. In July of the next year a disastrous explosion took place at a factory in Faversham where guncotton was being manufactured. Twenty men were killed. It is uncertain why exactly the explosion occurred, however it soon became apparent that 'green' cellulose nitrate (cellulose nitrate from which the acid has been pressed) was not very stable. Green cellulose nitrate will spontaneously combust in oxygen at much lower temperatures than materials which have been boiled stabilized. Instability in cellulose nitrates has been attributed to three possible causes⁶:-

(i) residual mineral acids in the nitrated material. Nitric acid has been shown to be relatively easy to remove by boiling, however, sulphuric acid is not so easily removed,

(ii) sulphate esters - see Chapters 2 and 3,

(iii) an oxidation product of cellulose.

The Nitrating Species

One of the points of interest in the technical nitration of cellulose with mixed acids is the control of DOS ($\%N_2$) and how this is related to the composition of the acid mix. The maximum DOS obtained in the zone of technical nitration is 2.77 (13.5 $\%N_2$). In nitric acid-water mixes nitration is considered to be equilibrium controlled except in the very strong acids where DOS is considered to be limited by the accessibility of hydroxyls to the nitrating acid. The limiting DOS of acids from the technical zone has been explained in terms of both 'equilibrium' and 'accessibility'.^{6,13} The equilibrium control of DOS in mixed acids is well established,^{6,15} however, in the near anhydrous mixed acids that nitrate up to a DOS of 2.77 it has been proposed that complete nitration (i.e. a DOS of 3) can not be achieved because the acids can not penetrate throughout the crystalline cellulose regions. Both the accessibility and equilibrium arguments are considered in some depth in this and the following chapter. The confusion that exists over the control mechanism of DOS is complicated by an ignorance of the nitrating species in technical mixes.

The nature of the nitrating species in technical mixed acids has been a matter of considerable debate in the literature.^{6,7} In his review of cellulose nitrate chemistry (1955) Miles⁶ came down firmly in favour of anhydrous nitric acid using the arguments employed in Section 1.1.2 to rule out the possible involvement of the nitronium ion which in nitration. The evidence Miles cites in favour of nitric acid is persuasive, the

strongest evidence comes from comparison of the nitric acid vapour pressure above a mixed acid and the DOS to which the mix will nitrate cellulose.

From studies of the nitric acid vapour pressure above mixed acids it has been shown that the concentration of free nitric acid, that is acid that is not chemically associated with either the sulphuric acid or water, in a particular mix and the DOS to which cellulose will nitrate in that mix are related.^{29,30} Sapozhnikov^{29,30} proposed that the concentration of free nitric acid in a mixed acid and the vapour pressure of nitric acid above the mix are related thus:-

$$\frac{V. \text{ pressure of acid}}{[\text{ free acid in mix }]} = k$$

It follows from this relationship that a high nitric acid vapour pressure above a mix is indicative of a high concentration of free nitric acid in the mix.

Depression of the vapour pressure corresponded to hydration of the nitric acid in the mix, i.e.

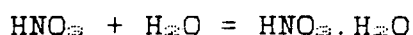

Very low vapour pressures corresponded to di or tri - hydrates. Expressing the relationship between the nitric acid vapour pressure and the composition of the mixed acid graphically, it can be seen that the curves showing the variation of nitric acid vapour pressure with acid mix composition closely resembles those in the 3-way nitration diagrams of cellulose, see Figures 1.4 and 1.5. From this result Sapozhnikov deduced that the nitrating capacity of mixed acids was dependent on the nitric acid vapour pressure of the mixture and hence, the nitrating

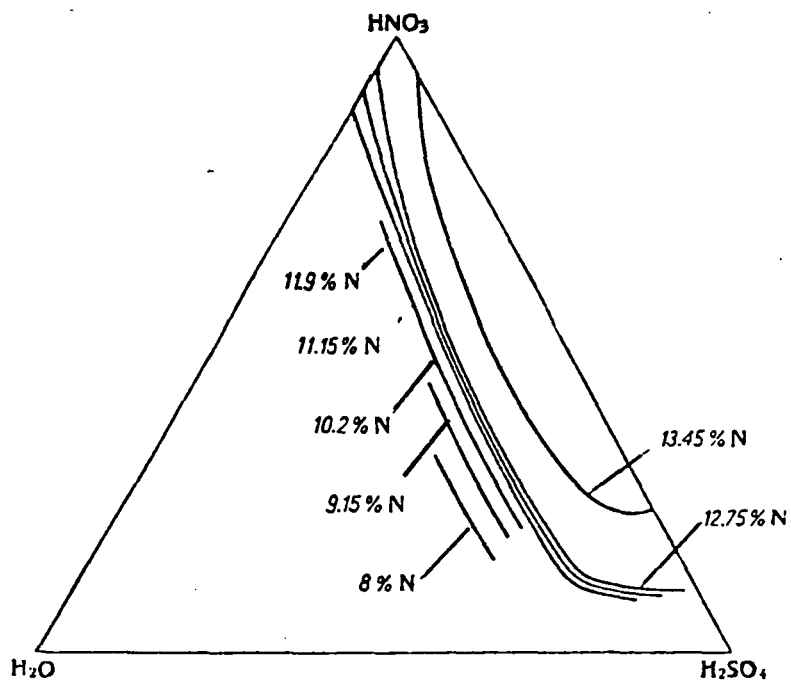

Nitration of cellulose. A modified Sapozhnikov diagram with curves of equal nitrogen content in nitrocellulose. Composition of acid mixtures in weight %.

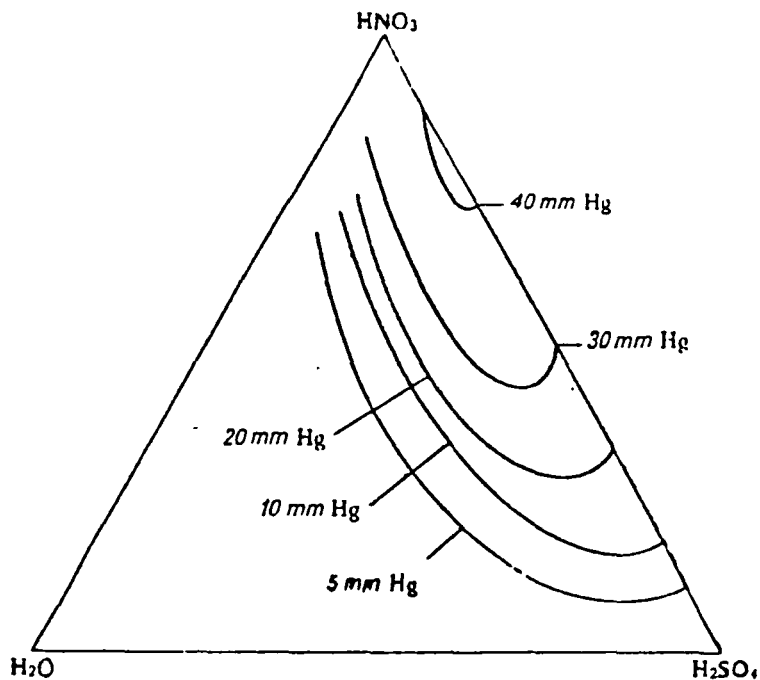

Isobars of HNO_3 vapour pressure in nitrating mixtures. A modified Sapozhnikov diagram. Composition of acid mixtures in weight %.

Figures 1.4 and 1.5

effectiveness of a mixed acid increases as the amount of free nitric acid in the mix increases.

Miles²⁶ predicted on the basis of vapour pressure measurements that the highest DOS to be achieved by nitrating in the technical zone would be employing an acid of composition :-

Nitric Acid	24.3 %
Sulphuric Acid	65.8%
Water	9.9 %

This result is in close agreement with the mix experimentally found to give the highest DOS :-

Nitric Acid	25.3 %
Sulphuric Acid	63.4 %
Water	11.3 %

However, not all authors are happy with this casting of nitric acid as the effective nitrating agent in mixed acids, nor the arguments employed to rule out the nitronium ion²⁶. Recently the work of Munro, Fowler and Short^{21, 22} has strongly favoured a different role for nitric acid as a precursor to the nitronium ion, NO_2^+ , which they believe to be the nitrating species. This work is presented in Chapters 2 and 3.

The Nitration Equilibrium of Cellulose in Mixed Acids

Berl and Klaye¹⁵ were the first workers to experimentally investigate the denitration of cellulose nitrates in mixed acids. A series of cellulose nitrates of high DOS were immersed in acid mixes that could not nitrate fresh cellulose to such a high DOS. However, although the cellulose nitrates denitrated on immersion, the final DOS of the denitrated materials was still higher than that expected from the nitrating capacity of the acid mixes employed. Berl and Klaye considered that equilibrium was not reached. This phenomena of only partial denitration has since been reported by other authors^{6, 33}. It is largely as a result of such experiments that some authors still prefer to discuss nitration and denitration in terms of accessibility rather than equilibrium.

Demougin and Bonnet³⁴ have shown that if a cellulose nitrate is denitrated for long enough in an acid mix, equilibrium is eventually established. However, at long immersion times considerable degradation of the cellulose can occur, especially in mixes of high water content³⁵.

The quickest denitration occurs in acid mixes that are able to cause the cellulose to swell.⁷ Thus, the higher the proportion of nitric acid in the acid mix, the more rapid the rate of denitration.

The Anomalous d₁₀₁ Spacing

The structure of the unit cells of cellulose and cellulose nitrate are considered in detail in part II of this chapter. However, it is pertinent to briefly review the processes that occur in the fibre during nitration here.

Change in molecular structure of cellulose nitrate as the hydroxyl groups are progressively replaced by nitrate groups has been well studied and it is now established that the conversion coincides with a massive change in the dimensions of the unit cell³⁶. Changes in the spiral angle and the nature of the helix have been recorded³⁷. Mathieu³⁸ was perhaps the first worker to observe the linear relationship that exists between the d(101) interchain spacing and the nitrogen content of the cellulose nitrate. Trommel³⁹ has extensively studied the d(101) spacing as a function of DOS and his results are summarized in Figure 1.6.

Although the d(101) spacing in cellulose is very sensitive to nitration Miles⁴⁰ and Trommel³⁹ have both reported that the d(101) spacing of cellulose trinitrate is not sensitive to denitration, see Figure 1.6. The d(101) spacing of a high DOS material that has undergone denitration does not revert back to the spacing that would be anticipated on the basis of nitration.

It would seem that, once formed, the conformation adopted in the unit cell of the cellulose trinitrate is particularly stable and resistant in some way, perhaps

(as it has been suggested)¹³ because of a change in hydrogen-bonding, to normal hydrolysis.

Trommel²¹ has suggested that in high DOS materials the fibre is so well crystallised that acid mixes can-not, or are slow to, penetrate and hence denitration is slow. This hypothesis is supported to some extent by the X-ray diffraction pattern of cellulose trinitrate which is extremely sharp and clear. Denitrated cellulose nitrates also display anomalous solubilities in a variety of solvents, e.g. denitrated materials in general are less soluble in a mixture of alcohol and ether (2:1) than their nitrated counterparts.

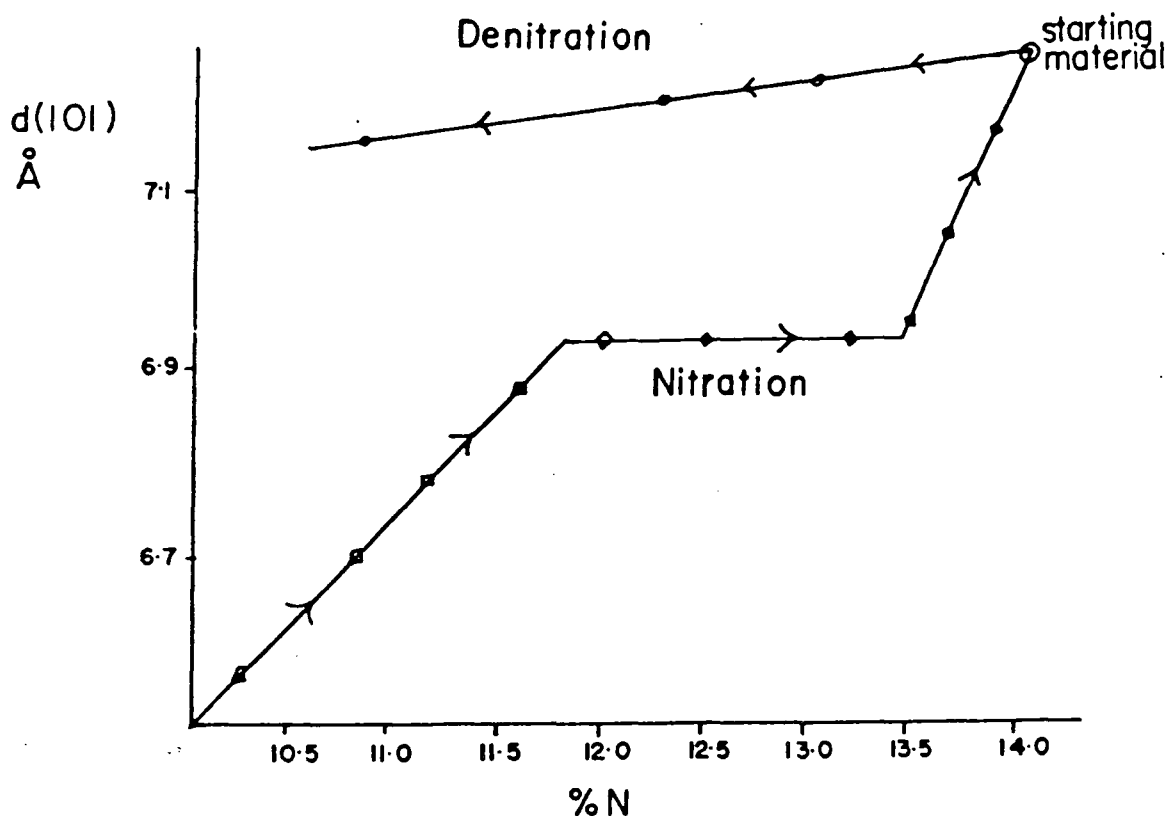

Figure 1.6 Graph of mean X-ray d (101) spacing against DOS for nitration and denitration²¹

1.1.4 Other Nitrating Mixes for Cellulose

Phosphoric Acid Mixes^{7, 33}

Of the many types of acid mix that can be employed to nitrate cellulose, the phosphoric-nitric acid mix is the next most useful in terms of industrial importance after the sulphuric acid-nitric acid mix.

These mixes have two distinct advantages over technical mixed acids:-

(i) the preparation of extremely high DOS materials are feasible in these mixes (i.e. DOS > 2.77)

(ii) stabilization of the nitrated product is very easy (ten minutes boiling is sufficient).

Further, there is appreciably less depolymerization of the product when nitrating with phosphoric-nitric acid mixes (although the product is more swollen).

However, a major problem with phosphoric-nitric acid mixes is their corrosive effect on the nitrating vessel, glass or steel.

Surprisingly little effort has been put into understanding the mechanism of nitration in phosphoric-nitric acid mixes (especially when compared to the attention that the sulphuric-nitric acid mixes have received).

Nitric Acid with Acetic Acid and Acetic Anhydride

Acetic acid and acetic anhydride are common partners of nitric acid for nitrating purposes⁴⁰. These mixes nitrate to very high DOS (2.9-3.0). Cellulose nitrates prepared from acetic acid-anhydride mixes are reported to

be less swollen than those prepared from other acid systems⁴¹.

Nitric Acid and solutions containing inactive Substances

Anhydrous nitric acid is miscible with certain organic liquids⁷. The first reported use of chlorinated hydrocarbons as an inactive component in the nitrating mix appeared well over 50 years ago⁴². Carbon tetrachloride was substituted for part of the technical acid mix replacing the large excess of sulphuric acid. An acid mix composed of:-

Nitric acid	18 %
Sulphuric acid	5 %
Nitrogen dioxide	2 %
Carbon tetrachloride	75 %

with an emulsifying agent (naphthalenesulphonic acid) gave a cellulose nitrate of 11.8 % nitrogen. Bouchonnet et al⁴³ have reported preparing a tri-nitrated cellulose in a mixture of dinitrogen pentoxide and carbon tetrachloride. Other workers have reported the nitration of cellulose in various organic media employing anhydrous or 95 % nitric acid^{44, 45}

Part II CELLULOSE STRUCTURE

1.2.1 Introduction.

The expected DOS from nitration in a particular mixed acid can be roughly estimated by reference to Figure 1.2. However, the usefulness of nitration diagrams is limited. This is because figures like 1.2 take into no account the effect that cellulose structure plays in the nitration reaction. The source and pre-treatment of the cellulose fibre has a profound effect on its reactivity with a variety of different reagents. It is generally accepted that cellulose I, the crystalline form of naturally occurring cellulose, is unique and does not depend on the source of the cellulose. However, as will be shown towards the end of this chapter, celluloses of different source exhibit very different levels of crystallinity.

1.2.2 The Cellulose Molecule ^{46, 47, 48}

In 1838 Anselme Payen⁴⁶ proposed that the cell wall of a large number of plants are constructed of the same substance to which he gave the name cellulose. Payen's suggestion has stood the test of time and it is now firmly accepted that the structural material of higher plants is in fact a poly-cellubiose made up of anhydroglucose residues joined together by a 1-4 beta linkage⁴⁶, see Figure 1.7.

The importance of cellulose to the quality of our everyday lives can not be underestimated and it is our

often led chemists to regard cellulose as a simple long chain polymer. Although, celluloses from different sources will all have the same chemical formula they can differ considerably in their fibre structure.

1.2.3 Cellulose Sources

Pure cellulose can never be found in nature. The cotton fibre is the purest natural source of cellulose; it rarely contains more than 5 % of other substances. In wood and plant stalks cellulose is associated with large quantities of other substances such as lignin and the so-called ' hemicelluloses ' (they are infact polysaccharides). The association between cellulose and lignin in the plant stalk has often been liken to that between steel and concrete in tall buildings⁵¹.

It is beyond the scope of this thesis to present a comprehensive review of all cellulose sources; some of the more important celluloses are considered with references for further detail.

(1) Wood Pulp

Wood pulp is now the major source of cellulose for the preparation of cellulose nitrates and other large scale dervatives of cellulose, as well as the manufacture of man made fibres e.g. rayon⁵. There are two major classes of pulp-yielding trees, the dicotyledenous (hardwood) and the gymnosperm (softwood) trees.

The wood fibre wall consists of, on average, 45 % cellulose, 21 % lignin and 34 % hemicellulose in hardwoods; 42 % cellulose, 29 % ligin and 28 % hemicelluloses in softwoods⁵².

The crystallinity of cellulose in wood fibres has been determined to be between 65-70 % by x-ray diffraction⁵³. It is the crystalline cellulose microfibrils that give cellulose its tensile strength. The structure of an idealized fibre is presented in figure 1.8. From this figure it can be seen how the wood fibre (tracheid) is built up from the cellulose fibrils. There exist two walls, the primary wall (P) and the secondary wall (S); the secondary wall can nearly always be seen to be made up from 3 distinct layers S₁, S₂ and S₃. In the secondary walls the fibrils are orientated at specific angles in the 3 different layers; in the primary wall the fibres are disorientated.

The middle lamella (M) is not an intergral part of the cellulose wall, it contains a very high proportion of lignin and acts to hold the fibres together. Hemicellulose is probably located on the fibril surface and in the interfibrillar spaces.

Cellulose wood pulp is prepared from the disintergration of wood fibres in a hot solution of either sodium hydroxide or calcium sulphate⁶. At this stage the lignin and hemicelluloses are removed, although a small quantity of pentosans may remain (< 5 %). Cellulose wood pulp is usually 95-99 % pure. It has been reported that crystallization occurs in the fibre during chemical pulping⁵⁵.

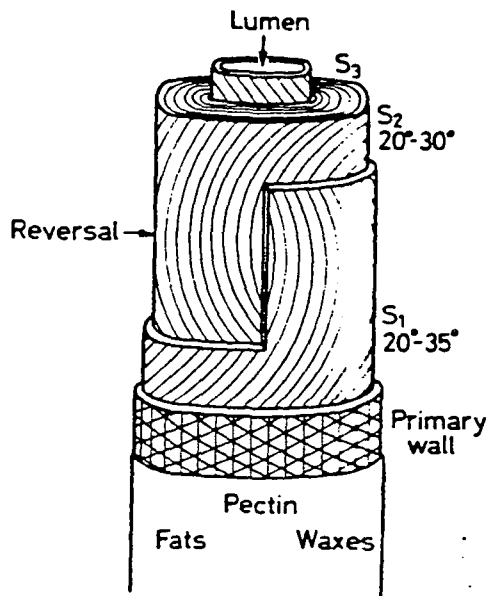

Figure 1.8 Structure of the cotton fiber.

(ii) Cotton²³

Cotton is the seed hair that is extracted from the plants of the genus *Gossypium*. The fibre length can vary from 1-10 cms and its breadth 10-25 μm .

(iii) Cotton Linters

The normal cotton hair is considered to valuable to use for nitration, although waste material which is considered unsuitable for weaving or spinning is often used to prepare cellulose nitrates. This material is usually referred to as cotton linter. It is often incorrectly asserted that linters are immature cotton because of the linters average length, 0.05-0.5 cm.

Examination of linters by optical microscopy reveals that thickening of the secondary walls (associated with maturity) is complete. The macroscopic fibre structure of wood pulp has been described above; at this level the structure of the wood and cotton fibre are very similar. A thorough pressure scour (boiling under pressure with dilute alkali) removes almost all the non-cellulosic components from the cotton. The final product is at least 99% pure and it is because of its purity and the high level of crystallinity that most workers have chosen to study the structure of the cotton fibre; as oppose to other naturally occurring cellulose fibres. In the following sections the structure of the cotton fibre is considered in further detail. However, it is generally accepted that the discussion presented applies equally to any other naturally occurring cellulose fibre.

1.2.3 The Fibrillar Structure

By optical microscopy it can be seen that the cotton fibre is built up from thousands of smaller fibrils organized in 3 distinct layers (see above). The fibrils are smooth and no evidence for branching has ever been found. The fibrils are of the order of at least 2000Å thick. The study of these fibrils by electron microscopy has revealed much smaller units, microfibrils of the order of 200-300 Å thick. Further disintegration has shown that these microfibrils can be split up into elementary or basic fibrils of about 30-60Å thick^{2a}. The size of the elementary fibril has also been investigated by chemical techniques.

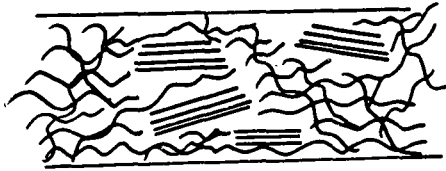

(a) Micelle Theory

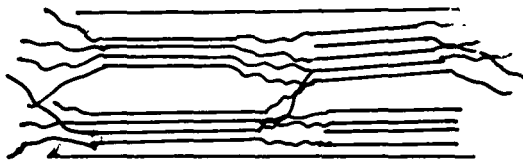

(b) Fringed Micelle Theory

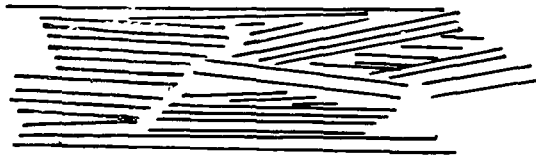

(c) Crystalline Microfibril Model

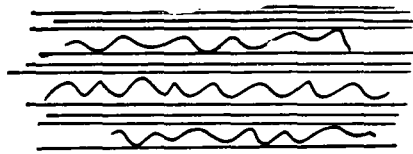

(d) Veined Model

Figure 1.9 Proposed models for cellulose

Haworth et al⁵⁵, from methylation studies of the accessible surfaces of the elementary fibril (i.e. surface hydroxyls), have shown the elementary fibril cross section to be 8 x 10 cellulose chains (or 40 x 50 Å). These dimensions are in reasonable agreement with the estimated by electron spectroscopy.

It is important to consider how the cellulose chains are arranged in the fibre. Long before the advent of x-ray diffraction techniques Nageli⁵⁶ proposed a micellar theory to explain the packing of cellulose chains in the fibre, see figure 1.9.a. This assumed the presence of brick like crystalline micelles within the cellulose fibre. From the first diffraction patterns obtained of the cotton fibre, ca. 1920s, it was deduced that the fibre was indeed crystalline in part and the crystal size was estimated to be 5-10 nm in diameter and 50-60 nm in length⁵⁷. The diffuse nature of the x-ray patterns were attributed to the presence of amorphous cellulose in the fibres. It was suggested that the amorphous material in a fibre acted as a cement holding the crystallites together⁵⁸. This interpretation of the diffraction data was at the time compatible with contemporary chemical thought. It was known that cellulose was a polymer and early estimates of the degree of polymerization (d.p) were in the region of 100-200 glucose units.

However, with developments in new physical techniques, in particular viscosity measurements, the early estimates of d.p. were revised, Staudinger and

Mohr⁵⁴ (1937) indicated a d.p. of about 3000 to be more appropriate and therefore early micellar theory became untenable. With the discovery of the high polymer nature of cellulose the fringed micelle concept was proposed, Figure 1.9.b. According to this theory, a cellulose chain will run through several crystalline and amorphous domains.

The discovery of the elementary fibril led workers to consider that the cotton fibre is near, or 100% crystalline. Briant and co-workers⁵⁵ have reported that the elementary fibril is 100 % crystalline and they propose that any scattering observed in the x-ray diffraction pattern, which was previously attributed to amorphous domains in the cotton fibre, arises from lattice distortions, along the surface, or periodically across the length, of the elementary fibril. This conclusion is supported by the earlier work of Muhlethaler⁵⁶ who using a staining technique to study the elementary fibril has reported that elementary fibrils appear to be completely crystalline along their entire length.

However, the 100% crystalline model is not a completely adequate description of the packing of the cellulose chains in the cotton fibre. The measured density of the cotton fibre is much lower than calculated from the unit cell and this result suggests that the cellulose chains are not packed as regularly as the 100% crystalline model implies.

The 'veined' model, Figure 1.9.d., explains the lower than expected density of the fibre while retaining a near 100% crystallinity in the fibre.

1.2.4 The Crystal Structure of Cellulose

The important evidence for the chemical structure of cellulose was obtained between 50-60 years ago. The six membered glucopyranose ring is now assumed, a priori, to be the fundamental unit of structure. There are 2 spatial forms that these rings can adopt, the chair and boat forms. With the advent of x-ray diffraction techniques, chemists have been able to address the problems of spatial arrangement, chain conformation and packing of cellulose chains in the elementary fibril. The first fibre diagram was reported by Polanyi⁶¹, who proposed that the unit cell of cellulose is orthorhombic and has a periodicity in the direction of the fibre axis every 10.3 Å. Polanyi's unit cell has not stood the test of time; the cell that is now widely accepted for cellulose type 1 was first proposed by Meyer, Mark and Misch⁶². They define the unit cell as monoclinic, with two anhydrocellobiose residues per cell, see Figure 1.10. The two chains run parallel to the fibre axis. The cellobiose residues are arranged on a two fold screw axis parallel to the fibre axis, i.e. a helix with two sugar residues per complete twist, and the repeat distance is 10.3 Å.

The boat conformation was dismissed as it would result in an impossible chain conformation. Meyer, Mark and

Misch proposed that adjacent cellobiose units were packed in an antiparallel arrangement.

More recently Gardner and Backwell⁴³ have claimed that there is closer agreement in the x-ray diffraction intensity data with a parallel packing arrangement. From the results of detailed crystal structure analysis, Sarko et al^{44, 45} have confirmed the parallel packing arrangement of adjacent chains.

The proposed hydrogen bonding in either packing arrangement is extensive. In the Meyer, Mark and Misch crystal lattice, Figure 1.11a, it is proposed that:-

(i) the hydroxyl groups on the carbon C-3 are intramolecularly hydrogen-bonded to the oxygen O5' in the neighbouring pyranose ring

(ii) in the 002 plane, adjacent celluloses are hydrogen-bonded between the hydroxyls located at the C-6 and the C-3" and perhaps also from the hydroxyl at the C-6 site and the oxygen atom O-4".

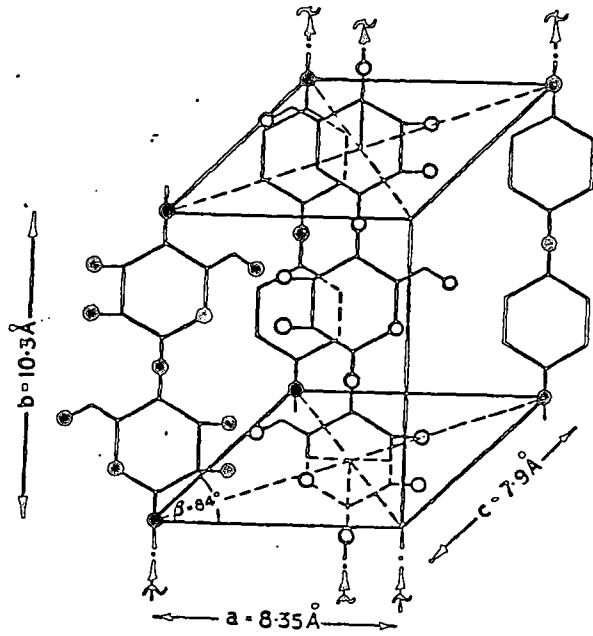

Figure 1.10 Unit cell according to Mark and Meyer

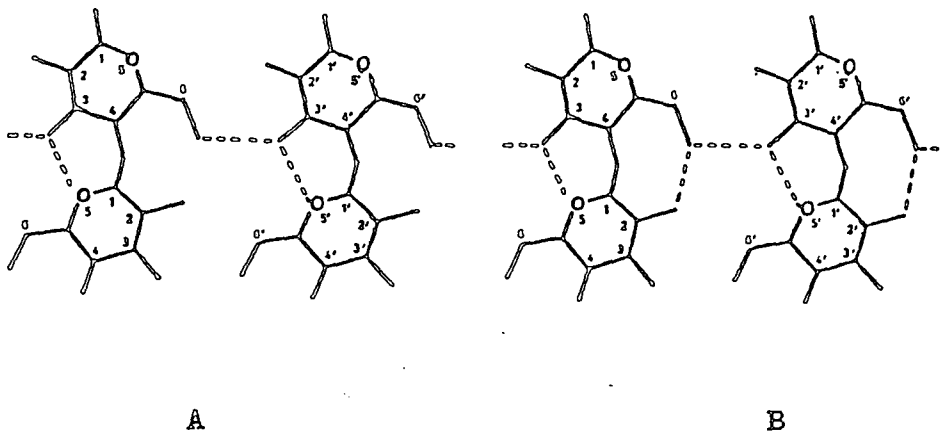

Figure 1.11 Intermolecular hydrogen bonding under the O02-lattice plane of cellulose I

In the Backwell model the described hydrogen bond is accepted and further hydrogen bonding is proposed in the 002 plane. The bonding proposed by Blackwell gives cellulose an apparent sheet like structure in which the 002 planes are held together by van der Waals forces, see Figure 1.11.b.

Although it is generally accepted that the unit cell of cellulose I, the crystalline form of naturally occurring cellulose is unique and does not depend on the source of the cellulose, Okano and Koyanagi⁶⁷ have very recently reported significant differences in the d-spacings between softwoods and hardwoods.

Cellulose II

Native cellulose fibres are frequently treated chemically to improve fibre properties. Cellulose II is produced when cellulose I is dissolved and precipitated (regeneration) or treated with an alkaline solution, e.g. 20 % sodium hydroxide, and then thoroughly washed (mercerization). It is generally accepted that cellulose II is a more stable allomorph of cellulose.

The unit cell after mercerization is still monoclinic and much of the structure described for cellulose I applies to cellulose II. It is generally accepted that adjacent cellulose chains are packed in an antiparallel arrangement,⁶⁸ although other structures have been suggested.⁶⁹

Mercerization is heterogeneous: one of the major objections to the proposed parallel arrangement of adjacent chains in cellulose I is the difficulty in explaining the change of chain direction that would occur with mercerization without solution of the fibre. Recently, however, Sarko⁶⁵ has proposed a mechanism for the conversion from a parallel to an antiparallel arrangement of the chains, without invoking solution of the fibre.

The intramolecular hydrogen bonding in cellulose II is considerably more complex than cellulose I.^{51,70} The difference in the reactivities of cellulose I and cellulose II to many chemical reagents has often been attributed to the different hydrogen bonding.

1.2.5 The Crystallinity (or Accessibility) of Celluloses
Infra-Red Deuteration Studies

From Infra-red studies of the hydroxyl-stretching band (3μ region) it has been observed that there is almost complete hydrogen bonding throughout the cotton fibre.⁷¹ When cellulose is treated with deuterium oxide it is observed from the 3μ region that there are two cellulose regions:-

(i) where hydroxyl groups hydrogen bond in a fashion that they are inaccessible to proton exchange with deuterium oxide,

(ii) where hydroxyl groups hydrogen bond in a fashion that deuterium exchange is observed to readily occur.

The percentage of hydroxyls in these 2 regions has been measured for a variety of cellulose fibres, table 1.3. From this table it can be seen that in the cotton fibre 58-60% of hydroxyls exist in regions where the protons do not exchange with the deuterium oxide and that 40-42 % of hydroxyls are hydrogen bonding in regions where exchange takes place. This result can be compared with the model of the elementary fibril proposed by Haworth, Jones, Roberts and Sagar⁵⁵ where it is suggested that 44% of the cellulose hydroxyls lie in the surface region. It does not seem unreasonable to suggest that in the cotton fibre the hydroxyls accessible to deuteration are located on the surface of the elementary fibril.

Table 1.3

Percentage of disordered material in various celluloses
assessed by a variety of techniques

Technique	Cotton	Wood pulp	Mercerized cotton	Regenerated cellulose
X-ray diffraction ^a	27	40	49	65
X-ray diffraction ^b	30	35	55-62	
Deuteration	36	55	59	72
Deuteration ^c	33	-	-	-
Moisture regain ^a	42	49	62	77
Non freezing water	16		23	48
Iodine sorption	13	27	32	52
Density	36	50	64	65

^a reported by Jefferies et al in ref 4 7

^b reported by Hermans P.H. and Weidinger A, J.Polymer Sc.
4, 135

^c reported by Mann J. in 'Methods in Carbohydrate Chem.
III' Ed. Whistler R.L. Publ. Academic Press, London 1963.

From Table 1.3 it can be seen that the percentage of hydroxyls accessible to deuteration for a series of different celluloses increases in the following order:-

cotton → wood pulp → mercerized cellulose → regenerated cellulose.

X-ray diffraction measurements of crystallinity indicate that the cotton fibre is the most crystalline of these celluloses and the regenerated cellulose the least.

Accessibility and Crystallinity (a word of warning).

Deuterium exchange studies monitor the availability or accessibility of cellulose hydroxyls to reaction, generally under conditions that avoid swelling of the cellulose fibre.

Crystallinity as measured by x-ray diffraction is, however, a measure of the order and disorder presumably existing in (or along the surface of) a crystalline material. An exact correlation between the percentage crystallinity and the percentage accessibility measured can not be expected, although it may be close. The percentage of order/disorder and the 'accessibility' (measured by several exchange techniques) for a variety of celluloses are presented in Table 1.3.

Hydroxyl Reactivity at the Elementary Fibril Surface

The relative accessibility of the hydroxyl groups at the C₂, C₃ and C₆ positions to reaction with N,N diethylaziridinium chloride (D.A.C.) have been measured for selected celluloses.^{71,72,73} The results are summarized in table 1.4. It is important to note that the conditions employed avoid swelling of the fibre (and therefore disruption of the hydrogen bonding). Hence reaction is limited to the surface of the elementary fibril.

Table 1.4 Relative availabilities of hydroxyls

Cellulose	[<OH-3>] / [<OH-2>]	[<OH-6>] / [<OH-2>]
EHC I*	0.28	0.55
Native cotton	0.27	0.82
Mercerized cotton	0.79	0.86
Disorder cellulose	1.00	1.00

* Exemplar hydrocellulose, highly ordered cellulose

From table 1.4 it can be seen that the availability of the C₃OH to reaction is about 25 % of that of the C₂OH in native cotton. The availability of the C₆OH to reaction is about 80 % of that of the C₂OH. A variety of celluloses of different crystallinity were studied and the results in table 1.4 show that as the level of crystallinity in the cellulose decreases the differences in the availability of the three sites to reaction diminishes. It is interesting to compare the relative accessibilities of the hydroxyls presented in table 1.4, to those

determined by solution state ^{13}C nmr for the nitration of cotton cellulose in mixed acids. From a study of the substitution distribution of nitrate esters in a range of different DOS materials it has been shown that the availability of the 3 sites to nitration is in the order $\text{C}_6 > \text{C}_2 > \text{C}_3$.⁷⁴ If the 'accessibility' of the hydroxyls to the nitrating mix limited the DOS achieved in a cellulose, then the order $\text{C}_2 > \text{C}_6 > \text{C}_3$ would perhaps have been expected. The order actually observed indicates that the extent of nitration at a particular hydroxyl site is equilibrium rather than accessibility controlled.

The relative accessibilities of the hydroxyls to reaction are dependent on the reaction conditions employed. The relative equilibrium constants for the reaction of hydroxyls at the C_2 and C_6 positions with methylvinyl sulphone dissolved in benzyltrimethylammonium hydroxide are $\text{C}_2 / \text{C}_6 = 2$ in 1.0 molar sodium hydroxide but 3 in 0.5m. sodium hydroxide.⁷⁵ Equal availability of the sites is approached as the molarity of the sodium hydroxide is increased. Rowland et al⁷⁶ have reported similar findings studying the relative reactivities of the hydroxyls in cotton cellulose with 2-chloroethyldiethylamine. In strong alkaline solutions the relative reactivities of the 3 sites are equal; in media of lower alkalinity ($< 4\text{m}$) the selective accessibilities of the 3 sites become evident; in media of even lower sodium hydroxide concentration the selective accessibilities become pronounced. Clearly it is the action of the sodium hydroxide on the cellulose which effects the relative accessibilities of the 3 sites.

Warwicker has shown that cellulose fibres swell in sodium hydroxide solutions.⁷⁷ Swelling must involve some disruption of the hydrogen bonding network in cellulose; from the discussion presented above it appears it is the disruption of the hydrogen bonding in cellulose that increases the relative availability of the C₆ and C₃ hydroxyls to reaction.

Hence, the availability of surface hydroxyls (in non-swelling reagents) for derivatization can possibly be explained in terms of the hydrogen bonding in the elementary fibril.^{57, 58} It is well established that there is a strong intramolecular C₃OH--O₆' hydrogen bond which will restrict the availability of the C₃-OH to reaction. There is also potential for a hydrogen bond between C₆-OH and C₂-OH. It has been suggested that the latter bond would restrict the availability of C₆-OH without restricting the availability of the C₂-OH to reaction.

Swelling of Cotton Cellulose in Acid and Alkali

Warwicker et al⁷⁷⁻⁸⁰ have investigated the swelling of cotton cellulose in acid and alkali. The degree of swelling was assessed by measurement of the variations in the width of the cotton fibre at its widest point. The nature of the swelling process, whether inter or intrafibrillar, was deduced from microscopic and x-ray evidence. Warwicker has shown that sulphuric acid (70% for 5 seconds) causes extreme interfibrillar swelling, but no intrafibrillar swelling. This was also shown to be the case at longer exposure times in all concentrations of

mixes of > 63% sulphuric acid solution of the cellulose occurs. Nitric acid however can cause swelling both inter and intrafibrillarly. At lower concentrations interfibrillar swelling dominates and at higher concentration intrafibrillar swelling dominates. At higher nitric acid concentration nitration also occurs.

1.2.6 The Structure of Cellulose Nitrate and other Derivatives.

Atkins et al⁸¹ have investigated the molecular conformation and packing in cellulose nitrate by X-ray diffraction and computer-modelling. The x-ray diffraction data obtained indicates that in highly nitrated celluloses (13.9% N) the anhydroglucose backbone is arranged as a 5-fold helix (i.e. 5 rings per repeat). A number of possible chain conformations exhibiting 5-fold helical symmetry were computer modelled; the most acceptable model was found to be a 5₂ helix. Packing considerations of the 5₂ helixes lead Atkins to conclude that adjacent chains are arranged in an anti-parallel fashion.

The recent the application of solid state ¹³C nmr to cellulose⁸²⁻⁸⁷ and cellulose derivatives^{88,89,90} has provided a wealth of new information on crystal structure,^{82,83,87} substitution distribution^{88,89} and morphology.⁸⁹ Discussion of the solid state nmr data is reserved until Chapter 3 where the solid state nmr spectra of cellophane and wood fibres are examined.

The morphology and sequence distributiuon in cellulose derivatives may be probed by a variety of other techniques, chemical and physical. Pethrick et al⁹¹⁻⁹⁵

have studied the dielectric properties of cellulose and its derivatives; significant differences in the relaxational characteristics are reported for changes in the nature of the side group and the pre-treatment of the sample prior to investigation. The use of dielectric relaxation to monitor the interaction between cellulose nitrate and nitroglycerin has been reported.²⁷

The use of positron annihilation to examine the distribution of cavities at a molecular level, in cellulose and derivatives has been reported.²⁸ Positron lifetime measurements provide a method for elucidating the nature of the free volume of a sample. Pethrick et al.²⁸ have employed positron annihilation to correlate the relaxational characteristics observed in cellulose acetates with the distribution of cavities in these materials.

REFERENCES

- 1 H. Bracconot, *Annl. Chim. Phys.*, 1819, 12, 185
- 2 R.J. Brewer and R. Bogan, *Encyclo. Polym. Sci. En.*, 1985, 3, 139.
- 3 U. Lotz *Nucl. Instr. Methods*, 1972, 147 (1), 149.
- 4 A. Dragu, *Nucl. Tracks*, 1979, 3(4), 197.
- 5 M.W. Geis et al, *J.Vac. Techn. B.* 1985, 3(1), 343.
- 6 F.D. Miles 'Cellulose Nitrate', Oliver and Boyd, London, 1955.
- 7 T. Urbanski, 'Chem. and Techn. Of Explosives', Vol II, Pergamon Press, 1984.
- 8 P. Vieille, *Compt. Rend.*, 1882, 95, 132.
- 9 P. Vieille, *Compt. Rend.*, 1884, 2, 212.
- 10 E. Knetcht according to Miles in ref. 6.
- 11 W. Baker and A.H. Bateman, *Ardeer 1930*, in ref. 6.
- 12 G.L. Wilson and F.D. Miles, *J. Chem. Soc. Trans. Far. Soc.* 1944, 40, 150.
- 13 J.W.C. Crawford, 1931 *Ardeer*, in ref. 6.
- 14 Chedin and Tribot, *Mem. des Services Chim de L'Etat*, 1947, 34, 277.
- 15 E. Berl and R. Kayle according to Miles in ref.6.
- 16 J.G. Hoggett, R.B. Moodie, J.R. Penton, K. Schofield 'Nitration and Aromatic Reactivity', Cambridge Univ. Press, 1971.
- 17 C.K. Ingold, D.J. Mille and H.G. Poole, *J. Chem Soc.* 1950, 2576.
- 18 W.H. Lee and D.J. Mullen, *J. Chem. Soc.*, 1956, 4463.
- 19 P.J. Stephenson, 1981, Ph.D. Thesis, Univ. of Durham.
- 20 Bruley according to T. Urbanski, ref. 7.
- 21 Lunge according to T. Urbanski, ref. 7.
- 22 E.B. Spalding in 'Cellulose and Cellulose Dervs.', Interscience, New York, 1954.
- 23 R. Jefferies, *Cell. Chem. Techn.* 1969, 3, 255.
- 24 I. Sakurada according to T. Urbanski in ref. 7.

- 25 B. Rassow and Wv Bonge according to T. Urbanski in ref. 7.
- 26 C.F. Schonbein, Philos. Mag. 1847, 7, 31.
- 27-30 A. Sapozhnikov in: Zh. Russ. Khim. Obstich 1903, 35, 126; Z. Physik. Chim 1904, 49, 697; Z Physik 1905, 51, 609; Z Physik 1906, 53, 225; Z ges Scheiss v Sprengstoffv. 1906, 1, 453; Z ges Scheiss v Sprengstoffv. 1909, 3, 201; Z ges Scheiss v Sprengstoffv. 1909, 4, 441 and 462.
- 31 A.H.K. Fowler, H.S. Munro and R.D. Short, Polym. Comm, 1986, 27, 251.
- 32 H.S. Munro and R.D. Short in 'Wood and Cellulosics', Eds. J.F. Kennedy, G.O. Phillips and P.A. Willams, Publ. Ellis Horwood, Chichester, 1987.
- 33 J. Trommel Commun N.V. Koninkl. Ned. Springstoff-fabrieken Amsterdam, No. 13.
- 34 P. Demougin, Mem. Poudres, 1930, 24, 147.
J. Bonnet, Mem. Poudres, 1930, 24, 157.
- 35 F.D. Miles and M. Milbourn, J. Phys. Chem., 1930, 34, 2598.
- 36 D. Jones in 'Cellulose and Cell. Derivs.', Eds. N.S. Bikales and L. Segal, Publ. Interscience, 1972.
- 37 E.D.T. Atkins, Polymer, 1978, 19, 1371.
- 38 M. Mathieu according to F.D. Miles, in ref. 6.
- 39 J.W. Green in 'Methods in Carbohydrate Chem.', Ed. R.L. Whistler, Publ. Academic Press, London 1963.
- 40 E. Berl and W. Smith according to J.W. Green in ref. 39.
- 41 C. Trogus according to J.W. Green in ref. 39.
- 42 Z.A. Rogovin and P. Paradnia, Cell. Chem. 1934, 32, 15.
- 43 A. Bouchonnet, Mem. des Poudres, 1938, 28, 295.
- 44 H. Yamaoka, T. Shiba, Makromol. Chem., 1966, 99, 117.
- 45 H. Yamaoka, T. Shiba, J. Polym. Sc. (B), 1966, 5, 622.
- 46 'Cellulose and its Deivatives' Eds. J.F. Kennedy, G.O. Phillips, D.J. Wedlock and P.A. Willams, Publ. Ellis Horwood, Chichester, 1985.
- 47 'Cellulose Chemistry and its Applications' Eds. T.P. Nevell and S.H. Zeronian, Pub. Ellis Horwood, Chichester, 1985.
- 48 'Wood and Cellulosics', J.F. Kennedy, G.O. Phillips and P.A. Willams, Publ. Ellis Horwood, Chichester, 1987.

- 49 A. Payen according to T.P. Nevell and S.H. Zeronian in ref. 47.
- 50 J. Warwicker in ref. 46.
- 51 H. Krasig in ref.46.
- 52 T.P. Nevell and Z.H. Zeronian in ref. 47.
- 53 H. Klug and C. Alexander in 'X-ray Diffraction Procedures', Pub. J. Wiley and Sons, New York., 1954.
- 54 T. Hattula in ref. 48.
- 55 S. Haworth, D.M. Jones, J.G. Roberts and B.F. Sagar, Carbohydrate Res., 1969, 10, 1
- 56 C. Negeli according to P.J. Stephenson in ref. 19.
- 57 R.G. Herzog, J. Phys. Chem., 1926, 30, 458.
- 58 H. Staudinger and R. Mohr according to R. Jefferies in ref. 23.
- 59 Briant et al, Adv. Carb. Chem., 1971, 26, 297.
- 60 K. Muhlethaler according to P.J. Stephenson in ref. 19.
- 61 M. Polanyi according to H. Krassig in ref. 47.
- 62 K.H. Meyer, H.F. Mark and L. Misch, Physik Chem. B. 1929, 2, 115; K.H. Meyer, L. Misch, Ber, 1937, 70B, 266. K.H. Meyer, L. Misch, Helv. Chim. Acta, 1937, 20, 232.
- 63 J. Blackwell and K.H. Gardner, Biopolymers, 1974, 13, 1975.
- 64 A. Sarko, Macromolecules, 1980, 13, 1183.
- 65 A. Sarko in ref. 48.
- 67 T. Okano and A. Koyanagi, Biopolymers, 1986, 25, 851.
- 68 J.F. Kolpak, M. Weik and J. Blackwell, Polymer, 1978, 19, 123.
- 69 R.E. Hunter and N. Dweltz, J. Applied Polym. Sci. 1979, 23, 249.
- 70 A. French in ref 47.
- 71 S.P. Rowlands, E.J. Roberts, J. Polym. Sc. Polymer. Chem. Ed., 1974, 12, 2099.
S.P. Rowlands, E.J. Roberts, J.L. Bose, J. Polym. Sc. Part A1, 1971, 9, 1431.
- 72 S.P. Rowlands, E.J. Roberts, J.L. Bose, C.P. Wade, J.Polm. Sci. Prt A1, 1971, 9, 1623.
- 73 V.O. Cirino, A.L. Bullock and S.P. Rowland, J. Polym. Sc. Prt A1, 1969, 7, 1225.

- 74 T. Wu, *Macromolecules*, 1980, 13, 74.
- 75 S.P. Rowlands, E.J. Roberts, *J. Tex. Res.* 1969, 39, 530.
- 76 S.P. Rowlands et al, *Text. Res. J.*, 1965, 35, 421.
- 77 J. O. Warwicker and A.C. Wright, *J. Applied Polym. Sci.* 1969, 11, 659.
- 78 J. O. Warwicker and A.C. Wright, *J. Applied Polymer Sci.* 1969, 13, 41
- 79 J. O. Warwicker, A.C. Wright and J.W. Clayton, *J. Applied Polym. Sci.* 1969, 13, 1037.
- 80 J.O. Warwicker in ref 46.
- 81 E.D.T. Atkins, *Polymer*, 1978, 19, 1371.
- 82 W.L. Earl and VanderHart, *J. Am. Chem. Soc.*, 1980, 102, 3251.
- 83 W.L. Earl and D.H. VanderHart, *Macromol.*, 1981, 14, 570.
- 84-85 P.J. Stephenson in ref. 46. and in ref.48
- 87 D.L. VanderHart and Atalla, *Macromolecules*, 1984, 17, 1465.
- 88 D.T. Clark, A.H.K. Fowler and P.J. Stephenson , *J. Macromol. Sci. Rev., Macromol. Chem. Phys.*, 1983, C23, 217.
- 89 J. Koeing, P. Patterson and J. Blackwell , *J. Polym. Sci., Polym. Phys. Ed.*, 1985, 23, 483.
- 90 R.A. Pethrick, S. Doyle, R.K. Harris, J.M. Lane, K.J. Packer, *Polymer* 1986, 27, 19.
- 91 D.J. Crofton, R.A. Pethrick, *Polymer*, 1981, 22, 1048.
- 92 D.J. Crofton, R.A. Pethrick and D. Moncrieff, *Polymer*, 1982, 23, 1605.
- 93 D.J. Crofton and R.A. Pethrick, *Polymer*, 1982, 23, 1609.
- 94 D.J. Crofton, R.A. Pethrick and S. Doyle in ref. 46.
- 95 D.J. Crofton and R.A. Pethrick, *Polymer*, 1982, 23, 1615.
- 96 B.D. Malhotra and R.A. Pethrick, *Polym. Commun.*, 1983, 19, 457.
- 97 F.S. Baker, M. Jones, T.J. Lewis, G. Privett, D.J. Crofton and R.A. Pethrick, *Polymer*, 1984, 25, 815.
- 98 S. Doyle, B.D. Malhota, N. Peacock and R.A. Pethrick, *British Polymer Journal*, 1984, 16, 15.

CHAPTER TWO - A REVIEW OF THE MORE RECENT LITERATURE
PERTAINING TO THE NITRATION OF CELLULOSE AND
PRELIMINARY INVESTIGATIONS TO ESTABLISH THE ACCURACY
OF TECHNIQUES EMPLOYED IN THIS THESIS

2.1.1 Introduction.

In Chapter 1 the long established features of the nitration of cellulose were discussed. However, over the past 8 years considerable advances have been made in the understanding of the nitration reaction by the application of new analytical techniques, in particular ^{13}C nmr and ESCA. In the course of this chapter the potential information available from the application of these techniques to cellulose nitrate chemistry is considered and the information already elucidated by the application of these techniques to cellulose nitrates is reviewed¹⁻¹².

However, as will become apparent, not all of the 'new' data produced by different workers employing these techniques is consistent; it is these inconsistencies, particularly in the published ESCA data, that are the focus of interest. The 'trend' in surface DOS, with acid mix composition, reported by Clark and Stephenson¹ is in complete contrast to that reported by Fowler² for the same series of acid mixes. Therefore, in the results and discussion an attempt to clarify this difference in reported data is made by investigating the procedures for the production of cellulose nitrate and its analysis by ESCA.

2.1.2 The Application of ^{13}C Nmr to Cellulose Nitrates

The resolution of many of the problems discussed in part I of the previous chapter requires an understanding of the bulk chemistry of cellulose nitrates. Solution state¹³ and more recently solid state¹⁴ ^{13}C nuclear magnetic resonance spectroscopy (nmr) have proved powerful tools for the identification and characterization of carbohydrate polymers.

In 1980 Wu¹⁵ published the first solution state ^{13}C nmr spectra of cellulose nitrates in d_6dmso . Although the spectra were poorly resolved Wu was able to assign the peaks in the anomeric C_1 region to mono, di and trisubstituted anhydroglucose residues. The effect of nitration at the C_2 , C_3 or C_6 positions, or any combination of these three, on the chemical shift of the C_1 carbon were assessed from the spectra of 'model' cellulose nitrates and other cellulose derivatives. Employing his assignments, Wu was in position to obtain information on the distribution of nitrate groups in the anhydroglucose residues for a series of different DOS cellulose nitrates; e.g. Wu reported that the extents of nitration of hydroxyls at carbons 2,3 and 6 for 1.22, 1.98 and 2.3 DOS cellulose nitrates are as shown in Table 2.1:-

Table 2.1 The Substitution Distribution of Nitrate groups in Nitrated Celluloses as estimated by ^{13}C NMR.

Extent of nitration			DOS	
at position			Nmr	Kjeldahl
2	3	6		
0.3	0.1	0.8	1.3	1.22
0.5	0.5	0.8	1.9	1.98
0.7	0.5	1.0	2.2	2.3

From this table it can be seen the rate of nitration is not the same at the C_2 , C_3 and C_6 positions; clearly the equilibrium DOS at different sites in the anhydroglucose residue are not the same for nitration in mixed acids.

However, Wu's analysis, based solely on the anomeric C_1 , is severely limited by the quality of spectra obtainable, a problem which can largely be overcome by employing the remainder of the ^{13}C nmr spectrum once appropriate assignments for the $\text{C}_2 - \text{C}_6$ carbons have been made.^{3,4} Solution state ^{13}C nmr has been widely employed throughout this thesis and therefore analysis of the ^{13}C nmr spectrum is reserved until Chapter 4. The remainder of this section is devoted to discussing some of the results obtained by the use of ^{13}C nmr in cellulose nitrate chemistry.

Clark et al³ have studied the substitution distribution of nitrate groups in the anhydroglucose residues for a series of cellulose nitrates prepared from mixed acids. The percentage of trisubstituted,

disubstituted, monosubstituted and unsubstituted anhydroglucose residues in the celluloses have been estimated from the nmr spectrum. A typical low DOS cellulose nitrate yields an n.m.r analysis of:³

DOS = 2.31

Partial DOS

C6	C3	C2	Trisub	2,6	3,6	6 mono
1.0	0.71	0.6	47%	24%	13%	17%

In Figure 2.1 the substitution distributions of the nitrated celluloses are displayed along with the substitution distributions of cellulose nitrates prepared by the denitration of a 2.83 D.O.S. material in various nitric acid-water mixes. From this figure it can be seen that the substitution distribution of the nitrated and denitrated materials are not the same at equivalent DOS. The difference in substitution distribution is manifest in the d(101) spacings for nitrated and denitrated materials. From this figure it can be seen that those materials having unsubstituted residues prepared by nitration in general have lower d(101) spacings than those prepared by denitration which do not have unsubstituted residues. At high DOS where nitrated and denitrated materials have similar interchain spacing the distribution of nitrate groups around the residues are similar.

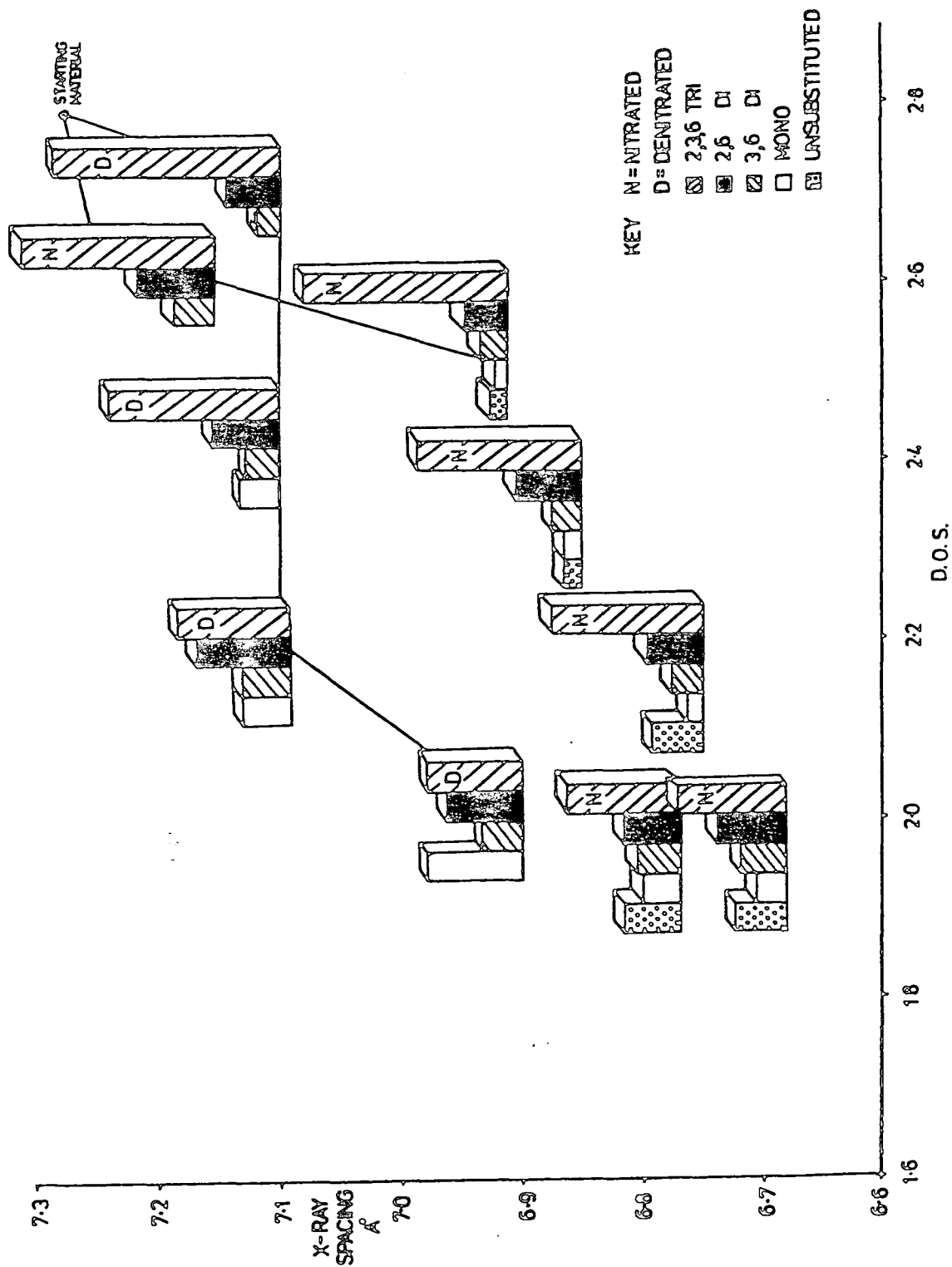

Figure 2.1 Block histogram of the nitrate ester distributions for given degrees of substitution versus the mean interchain d(101) spacings as measured by x-ray diffraction

From Figure 2.1 it is clear that in nitrated materials of high DOS (2.7) every anhydroglucose residue is at least mono-substituted. This result has an important bearing on the 'accessibility-equilibrium' debate (see Chapter 1). The 'accessibility' theory proposes that 2.7 is the maximum DOS obtainable in mixed acids because the nitrating acid mix can not penetrate into the highly crystalline regions of the cellulose fibre. However, the substitution of every residue demonstrates that the DOS achieved in mixed acids is not limited by the 'accessibility' of the crystalline regions of the fibre to the nitrating mix. Note, this result does not rule out the possibility that individual hydroxyls are inaccessible to the nitrating acid mix presumably due to particularly strong hydrogen bonding, i.e. microinaccessibility.

Wu¹⁵ has shown that substitution at the C₆ position in an anhydroglucose residue does not effect the shift of the C₁ position. However, substitution at the C₂' in the adjacent ring is manifest from the C₁ chemical shift. Hence, by knowing the substitution distribution of the nitrate groups and the assignments of the peaks in the anomeric region, it is possible to model the sequence distribution of the nitrated anhydroglucose residues along the cellulose chain.^{3,4} Comparing their ¹³C nmr data with what they would have expected to have observed if substitution were entirely random, Clark and Stephenson¹ have come to the conclusion that substitution in both nitrated and denitrated materials is not random, i.e. substitution at a particular ring increases the likelihood

of further substitution at that ring or on the two adjacent rings.

2.1.3 The Application of ESCA to Cellulose Nitrates

Clark and Stephenson¹⁷ were the first workers to realize the possible potential of utilizing ESCA (Electron Spectroscopy for Chemical Analysis) for studying the nitration-denitration reactions of cellulose at the fibre surface. ESCA has been successfully employed to investigate the surfaces of a wide range of polymeric systems¹⁸ e.g.

- (i) co-polymers^{17, 18}
- (ii) plasma polymerized polymers^{19, 20}
- (iii) surface modified polymers^{21, 22}

The theory behind the ESCA experiment is reviewed in appendix 1; in Table 2.2 the general features of ESCA are summarized.²³

Clark et al¹ made a preliminary investigation to determine the suitability of ESCA for characterizing cellulose nitrates. A series of model nitrogen, carbon, oxygen compounds were studied as thin films deposited in situ by a cold probe and reservoir shaft method on a gold substrate; from these studies a series of chemical shifts for carbon, nitrogen and oxygen in different chemical environments were produced. The results of this work are summarized in Table 2.3.

The distinct shifts in binding energy observed for the nitrate, nitrite and nitro functionalities in the N_{1s} core level have facilitated their easy identification. In the C_{1s} core level the large shift in binding energy

Table 2.2 The General Features of ESCA

Advantages for Surface Analysis

Typical sampling depth of 10-100 Å

All elements except H and He can be detected

High surface sensitivity

Simple sample preparation

Analysis of solids, liquids and gases possible

Well-established theory

Generally non destructive

Many information levels available

Disadvantages

Expensive

Artifact-prone

High vacuum required

Information Levels Available

Absolute core level binding energies- facilitate elemental, functional group and oxidation state analysis (inorganic and metallic compounds).

Shake up states



Auger parameters

Valence bands

Relative intensities of core levels facilitate quantitative compositional analysis of surface

Sample homogeneity (vertical and lateral)

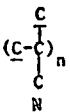
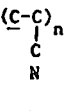
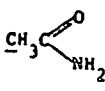
Table 2.3 Binding energies of selected nitrogen containing compounds (charge corrected)

Molecule	Experimentally determined B.E. (eV)		
	C _{1s}	N _{1s}	O _{1s}
	285.0	286.4	399.5
	285.0	286.3	399.3
CH ₃ NO ₂		286.8	406.8
CH ₃ ONO			534.3
CH ₃ CH ₂ CH ₂ CH ₂ ONO	285.0	286.7	405.0
CH ₃ ONO ₂			534.2
CH ₃ CH ₂ ONO ₂	285.0	287.0	408.1
CH ₃ CH ₂ CH ₂ ONO ₂	285.0	287.1	408.0
CH ₃ CH ₂ (ONO ₂)CH ₃	285.0	287.0	408.1
CH ₃ CH ₂ CH ₂ CH ₂ ONO ₂	285.0	286.5	408.0
			
	288.1	399.8	532.8
CH ₃ -O-C(=O)-NH ₂			
	289.8	400.4	534.1
			532.5

observed for carbon bound to the nitrate ester of 2.1eV was substantially greater than the 1.5eV normally anticipated for carbon singly bound to oxygen. Employing the chemical shifts determined in Table 2.3, Clark and Stephenson' were able to resolve the C_{1s}, N_{1s} and O_{1s} envelopes for a typical nitrocellulose, see Figure 2.2. The C_{1s} core level envelope was resolved into 3 component peaks. The central peak at 287.4eV was assigned to a nitrate or hydroxyl group at the C₂, C₃ or C₆ carbons; the peak at high binding energy to C₁ in the hemi-acetal functionality and the peak at 285eV to extraneous hydrocarbon which was shown to be limited to the cellulose surface.

The N_{1s} core level was resolved into two peaks, a very intense peak at 408eV and a less intense peak at 405eV, identified as nitrate and nitrite esters respectively. The use of conventional nitrite traps (e.g. urea or ascorbic acid) in the nitrating acids failed to eliminate the appearance of the nitrite ester and hence its presence was attributed to the decomposition of the nitrate ester during stabilization. Employing a suitable sensitivity factor Clark and Stephenson calculated the surface DOS of the cellulose nitrate to be 2.3. This value was in good agreement with that determined for the bulk by micro-Kjeldahl analysis.

The suitability of ESCA to the study of cellulose nitrates firmly established, Clark and Stephenson' undertook to investigate the reactions of cellulose in

mixed acids, by monitoring changes occurring at the fibre surface.

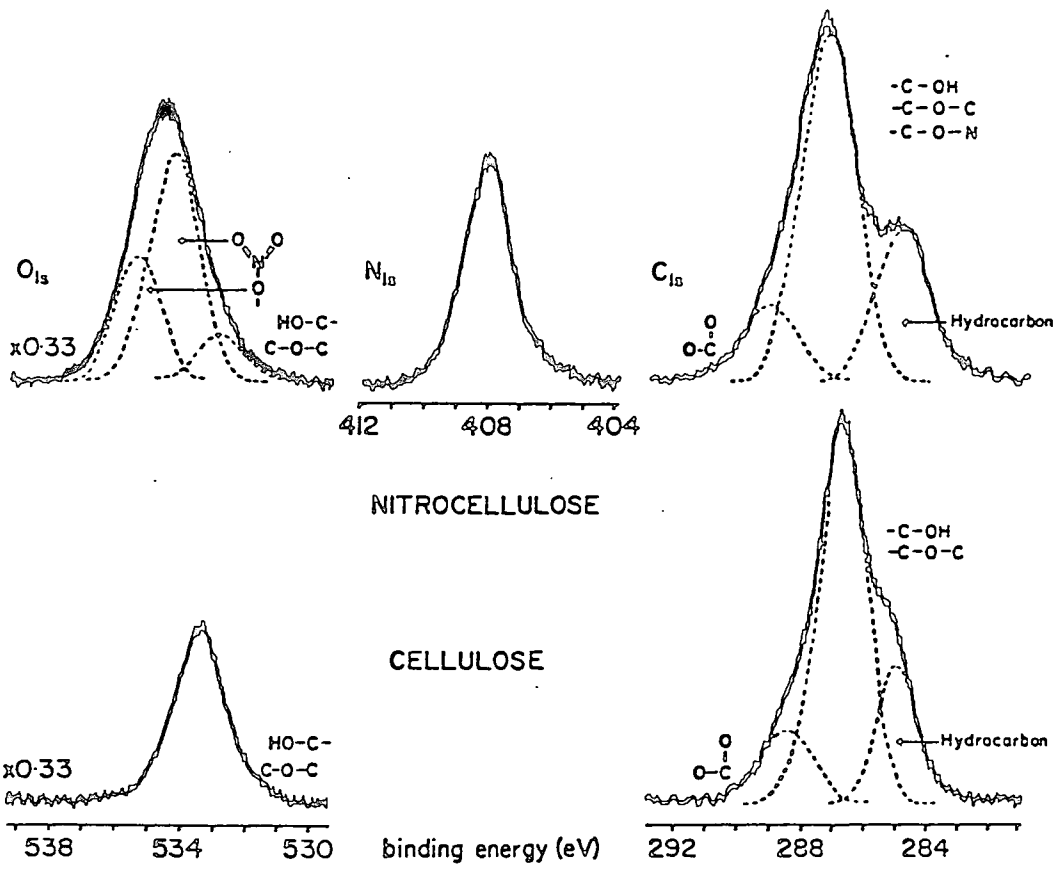

Figure 2.2 A typical ESCA spectrum of a nitrated cellulose

Many aspects of the nitration reaction are obscured by the heterogeneous nature of the reaction. The bulk nitration of cotton linters to a high DOS can take place in a matter of minutes. It has been observed that increasing the sulphuric acid content of the nitrating mix slows down the rate of esterification. The change in rate has been attributed to a decrease in the swelling ability of the acid mix. At the fibre surface the swelling capacity of a mixed acid will, obviously, not effect the rate of nitration observed.

Clark and Stephenson employed ESCA to follow the rate of nitration of cotton linters in a 75% H_2SO_4 , 22.2% HNO_3 , 2.8% H_2O technical mixed acid. The level of nitration at the surface was observed to remain constant from reaction times of 1 second to 1 hour, indicating that over the top 50 Å nitration is extremely rapid, far faster than ever previously envisaged. Utilizing the greater sampling depth of TiK α x-rays, nitration was shown to be complete in the top 100 Å of the fibre in a matter of seconds.

The penetration of various mixed acids into cellulose linters was followed by ESCA monitoring of the O_{1s}/O_{2s} core level area ratio. The use of this ratio as a means of obtaining a depth profile of the oxygen concentration in a polymer is described elsewhere.²⁴ The rate of penetration observed was fastest for mixes of low sulphuric acid content and slowest for mixes rich in sulphuric acid, the nitric acid concentration in the mixes was kept constant (22.5%).

2.1.4 Nitration : A ^{13}C nmr/ESCA investigation

Clark et al^{4,5} have followed the nitration of cellulose papers with time in a 60% H_2SO_4 , 22.5 % HNO_3 , H_2O acid mix at the fibre surface (by ESCA)² and in the cellulose bulk (by ^{13}C nmr)⁵.

Within experimental error the surface DOS was observed to remain constant at 2.2, from $t=1$ hour to the end of the experiment. After 168 hours nitration the cellulose was physically degraded and appeared as a powder. As reported earlier by Clark and Stephenson¹ the equilibrium DOS at the surface is established rapidly, however, the surface DOS at 1 hours nitration was observed to be particularly low, see Figure 2.3. The sample at 1 hours nitration was found to be very brittle, although samples taken either side of the hour were normal with respect to their physical characteristics.

From Figure 2.4 it can be seen how the substitution distribution of nitrate groups in the anhydroglucose residues changes with nitration time. It has previously been considered that nitration at a glucose residue might activate the residue (or adjacent residue) to further nitration. This hypothesis is supported to some extent by the data presented in the figure, where the overall contribution to the nmr spectra from unsubstituted glucose residues can be seen to be slow to reduce.

From the nmr data there is no visible change in DOS at 1 hours nitration. It was therefore considered the drop in DOS in Figure 2.3 to be limited to the surface only.²

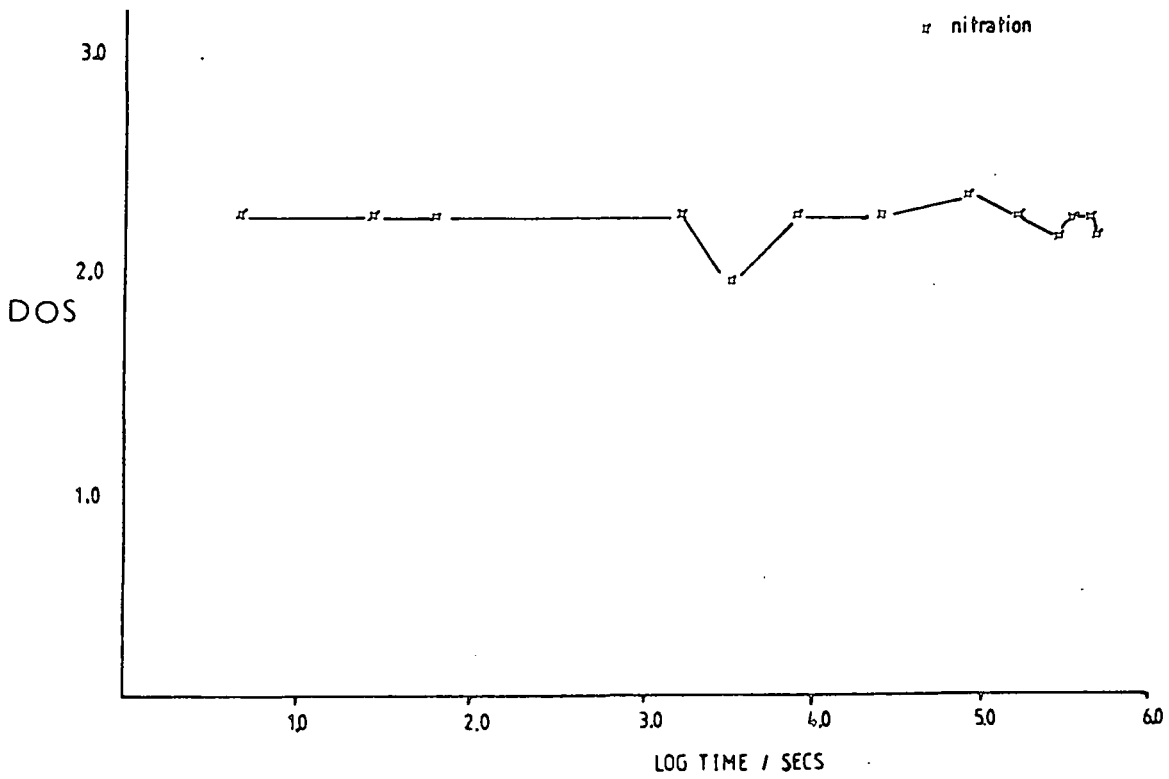

Figure 2.3 Surface DOS versus time for nitration

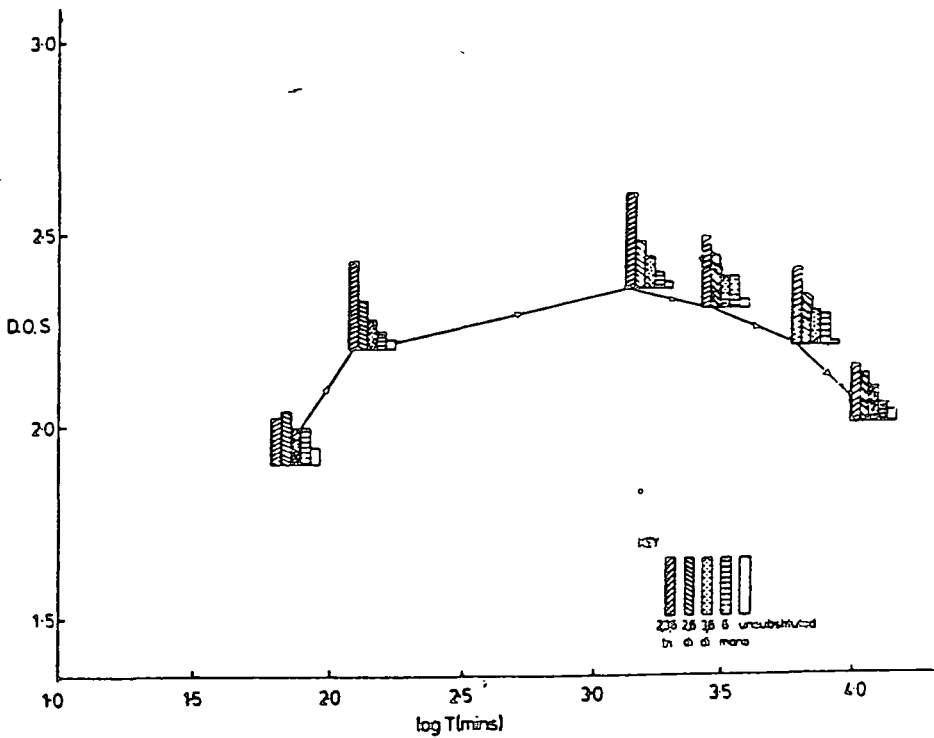

Figure 2.4 Block Histogram of nitrate ester distribution in a nitrating material versus time

2.1.5 Denitration: A ^{13}C nmr/ESCA study

In Chapter 1 the reversibility of the nitration reaction was discussed. Miles²⁵ has reported that the nitration reaction proceeds considerably faster in the cellulose fibre than the denitration reaction. Miles and Wilson²⁶ have suggested that the differences in rate can be attributed to the varying rates of diffusion of different acid mixes in and out of the crystalline cellulose regions. The denitration of cotton cellulose in mixed acids has been studied by ^{13}C nmr and it has been shown that the equilibrium partial DOS at the C_2 , C_3 and C_6 hydroxyls in denitrated anhydroglucose residues are not the same;^{4, 5} the order $\text{C}_3 > \text{C}_2 \gg \text{C}_6$ has been established.

Clark and Stephenson have monitored the rate of denitration of cotton cellulose nitrate in mixed acids at the fibre surface. The surface denitration of a 2.8 DOS cellulose nitrate immersed in a 70% H_2SO_4 , 22% HNO_3 , 8% H_2O mixed acid was monitored as a function of time.⁶ The change in surface DOS with time is displayed in Figure 2.5. From the figure it can be seen denitration at the surface is extremely rapid over the first few seconds, however, denitration continues to be observed, at a much reduced rate, for over an hour. Stephenson has proposed that 2 different rates of denitration are being monitored. The faster rate is considered to be denitration at the C_2 and C_3 sites; the slower rate denitration at the C_6 site.

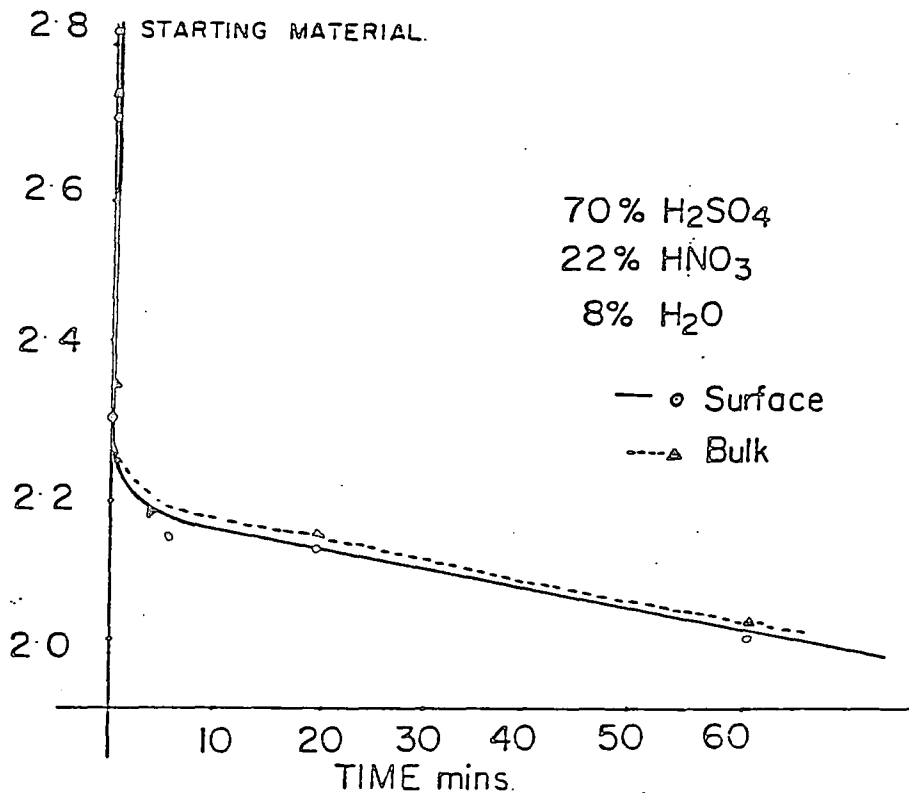

Figure 2.5 Denitration in a Mixed Acid

This study was followed up by Fowler^{2,5} who monitored the rate of denitration of a 2.83 DOS cellulose nitrate, in the form of papers, by ESCA and ¹³C nmr in a 60% H₂SO₄, 22.5% HNO₃, 17.5% H₂O mixed acid, see Figures 2.6 and 2.7

From Figure 2.6 it can be seen that denitration at the fibre surface is rapid; however the data is too confused to observe the two component rates reported by Clark and Stephenson.

From Figure 2.7 it is evident that denitration involves the conversion of the trisubstituted residues to 3,6-, 2,6-, and 6-monosubstituted residues. Only after extended periods of denitration do some unsubstituted residues appear. Comparison of Figures 2.6 and 2.7 reveals the difference in the rates of denitration observed between the surface of the fibre and for the fibre as a whole.

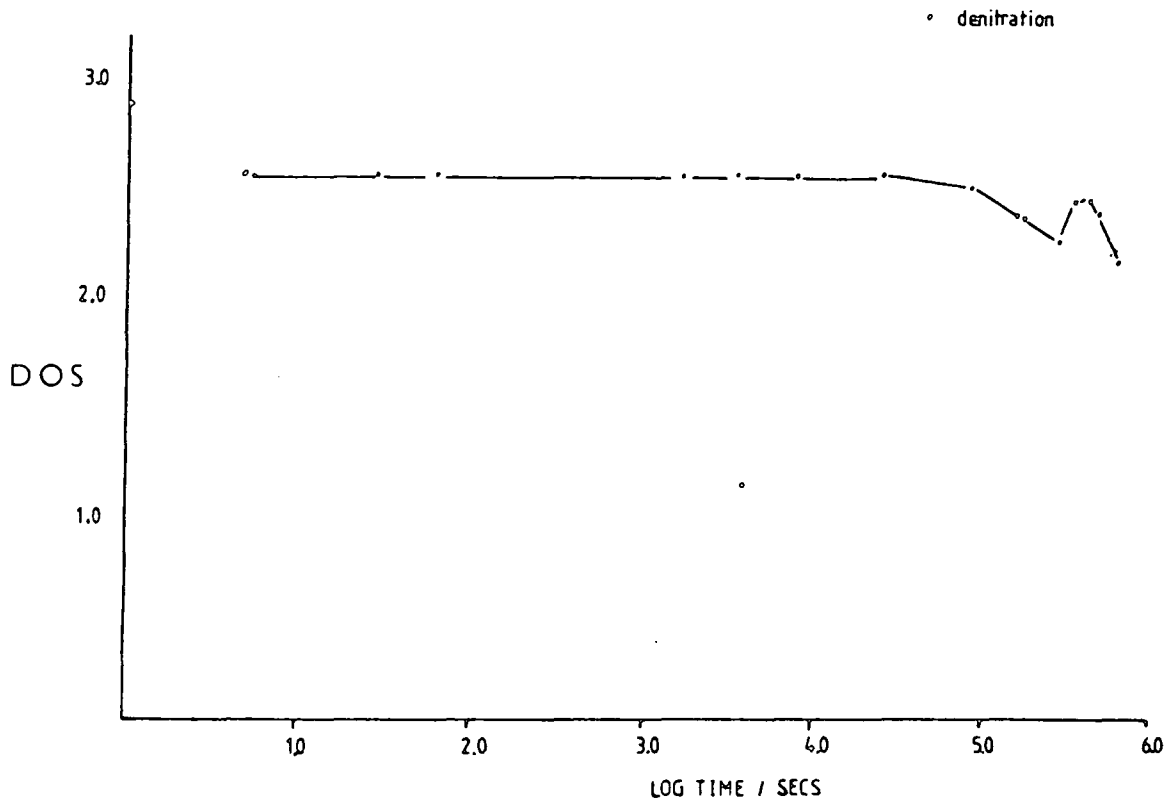

Figure 2.6 Surface DOS versus time for denitrating cellulose

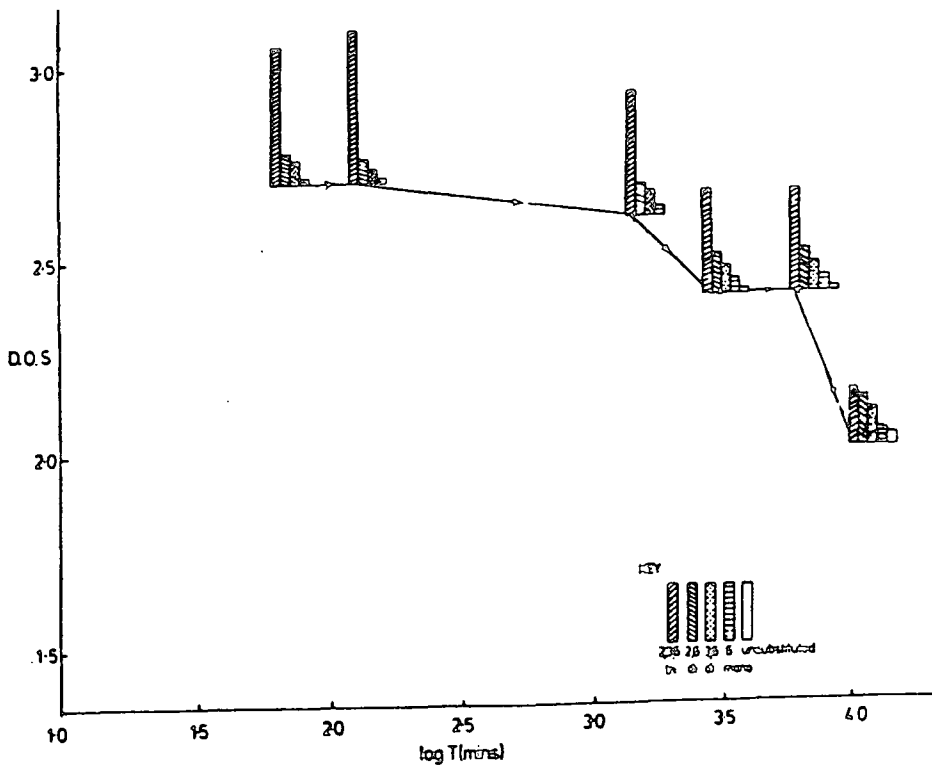

Figure 2.7 Block histogram of nitrate ester distribution in a denitrating material

Fowler repeated the experiment changing the cellulose source. The papers employed, above, were replaced by cellulose linters. Similar results were reported for the cellulose linters, but denitration of the fibre was observed to be more rapid and the appearance of unsubstituted anhydroglucose residues occurred much earlier in the experiment. The rapid appearance of unsubstituted anhydroglucose residues does not fit well with the discussion above, where it is proposed that denitration at the C₆ site is slow. Fowler attributed the change in the rate of denitration to the change in cellulose source.

Summarizing, it now seems certain that for cellulose in mixed acids:-

(i) the intrafibrillar swelling capacity of an acid mix controls the rate of denitration observed in the fibre bulk,

(ii) there exists two component rates to denitration as shown by ESCA. From nmr data it is suggested that the faster rate corresponds to denitration at the C₂ and C₃ positions and the slower rate denitration at the C₆ position, although not all the data available supports this view.

2.1.6. Surface DOS, Sulphate Esters and the Accessibility Argument

The maximum possible DOS (3) has never been achieved by nitrating cellulose in mixed acids. It is known that the composition of the acid mix employed controls the final DOS achieved in the cellulose. Two competing theories, 'equilibrium' and 'accessibility', have been put forward to explain this control of DOS, reviewed in Chapter 1.

Sulphuric acid has shown to be an effective swelling agent of cellulose, but it is thought that the action of the acid is limited to the interfibrillar regions and the fibril surface. Clark and Stephenson¹ have studied the surface and bulk DOS for a series of cellulose nitrates prepared in mixed acids. The aim of their study was twofold:-

(i) to examine the possible action of sulphuric acid on the surface DOS,

(ii) to resolve the 'accessibility-equilibrium' controversy.

Clark and Stephenson considered the existence of inaccessible cellulose regions in the top 50 Å of the fibre to be highly unlikely. Therefore they argued that if DOS in the fibre is controlled by the accessibility of the crystalline regions to the nitrating mix, then the DOS monitored at the surface will not be the same as that measured for the entire fibre (bulk).

The results of this study are presented in Figure 2.8.

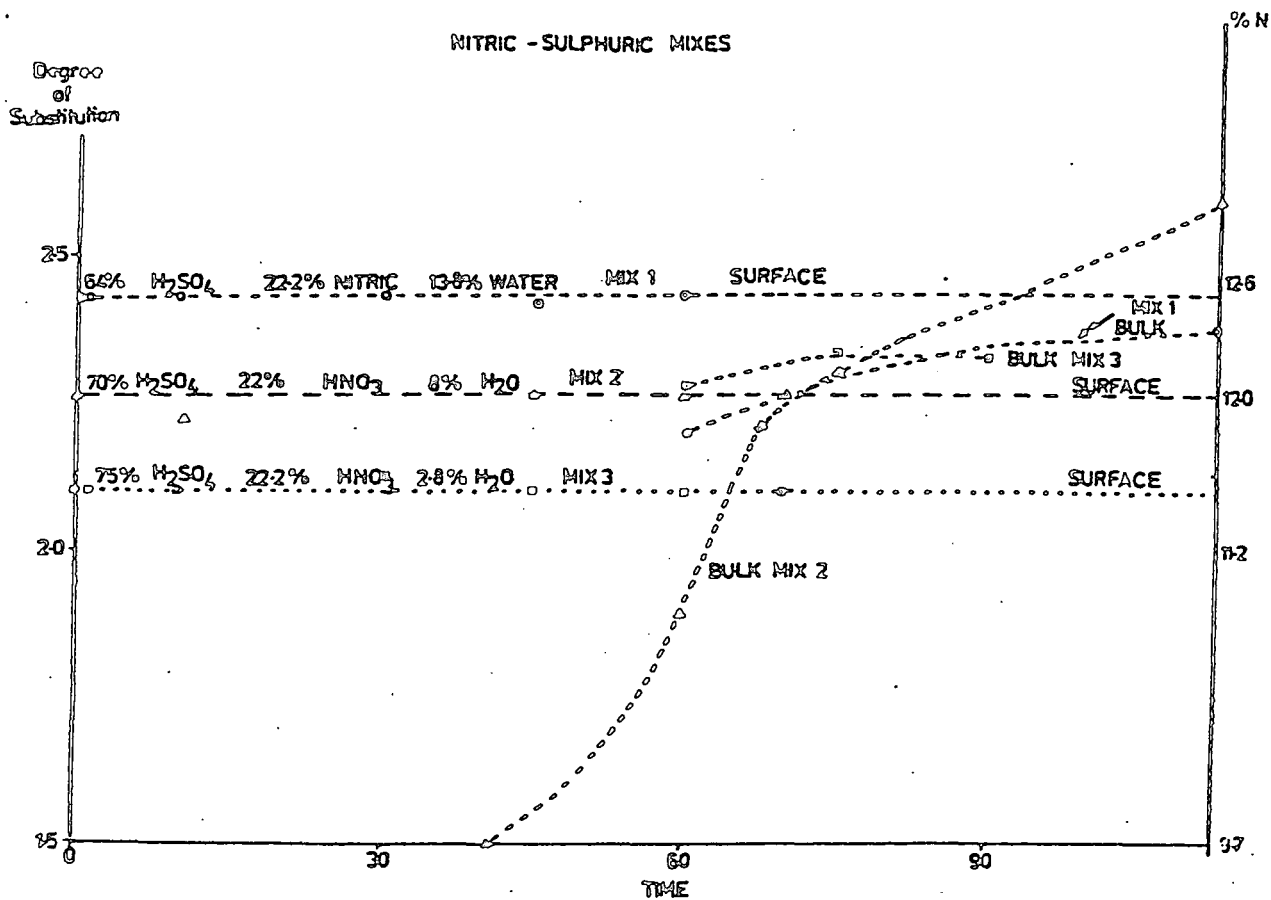

Figure 2.8 Surface and bulk DOS versus nitration time

From this figure it is evident that the overall or bulk DOS is greater than the DOS monitored at the fibre surface. This difference in DOS is particularly evident in the cellulose nitrates prepared in mixes of high sulphuric acid content (mixes 2 and 3). However, examination of the cellulose nitrates by $Ti_{K\alpha}$ x-rays revealed the DOS over the top 100 Å is more representative of the bulk. The DOS surface and bulk are in the closest agreement for linters nitrated in the 65% H₂SO₄ acid mix (mix 1).

Clark and Stephenson considered the low surface DOS observed for cellulose nitrates prepared in mixes 2 and 3 to be the result of competitive sulphonation at the fibre

surface. This hypothesis seemed to be supported by employing the dual Mg/Ti anode facility of the E.S. 300 to obtain a depth profile of sulphur concentration in the fibre surface. A signal from the S_{2p} core level was detected using $Mg_{K\alpha}$ x-rays, but not with $Ti_{K\alpha}$ x-rays. Munro²⁷ has since shown that the experimental sensitivity of the S_{2p} core level when studied by $Ti_{K\alpha}$ x-rays is insignificant and that it is in fact the S_{1s} core level that should be monitored. By monitoring this core level with $Ti_{K\alpha}$ x-rays it has been shown that there are sulphate esters present in the surface of cellulose nitrates prepared in technical mixed acids. However, it is expected that sulphur ought to be detected by $Ti_{K\alpha}$ x-rays since it has been shown sulphur is present in the top 50Å.

The theory of 'accessibility' was originally developed to explain why in mixed acids a DOS of 3 was never obtained. The nmr data presented in section 2.1.2 has ruled out the possibility of large regions of crystalline cellulose existing in a high DOS cellulose nitrate and has gone along way to establishing 'equilibrium' as dominant feature in the control of DOS. However, from figure 2.8 it can clearly be seen that the fibre structure does exert a strong influence in controlling the final DOS of a cellulose nitrate prepared from a mixed acid, since nitration is observed to be inhomogeneous, i.e. the surface and bulk DOS are not the same.

Clark and Stephenson⁴ have proposed that the nitration of cellulose in mixed acids can be described by:-

Nitration - denitration reactions

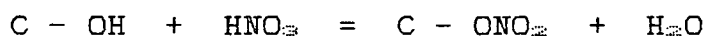
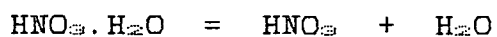

$$K = \frac{K_1}{K_2}$$

Sulphonation - surface

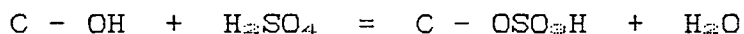

Work-up procedure

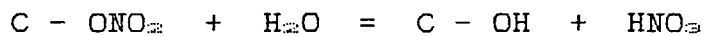

Although the above equations are generally accepted, describing the gross features of the nitration reaction in mixed acids, they provide no insight into the mechanism of nitration or denitration. The control of DOS in mixed acids and the identity of the nitrating species are considered in Chapter 3.

2.1.7 The Discrepancies in Surface DOS

The surface DOS reported by Fowler²² with acid mix composition are displayed in Table 2.2.

Table 2.2 Surface and Bulk DOS with Acid Mix Composition

	Surface DOS	Bulk DOS
75% H ₂ SO ₄		
22.5% HNO ₃	2.6	2.6
2.5% H ₂ O		
70% H ₂ SO ₄		
2.5% HNO ₃	2.3	2.3
7.5% H ₂ O		
60% H ₂ SO ₄		
25% HNO ₃	2.0	2.0
15% H ₂ O		

The values presented in this table do not agree well with those reported by Clark and Stephenson, Figure 2.8.

Clark and Stephenson worked with cellulose linters and Fowler worked mainly with cellulose papers. However, the discrepancy in surface DOS values cannot be simply explained by a change in cellulose source, since at the surface the structure of the cellulose is highly unlikely to influence DOS. Further, Clark and Stephenson observed no correlation between surface and bulk DOS for cellulose nitrates produced in mixes rich in sulphuric acid. Fowler observed close agreement in the surface and

bulk DOS for all acid mixes. From Fowlers' data it must be concluded that the action of sulphuric acid at the fibre surface does not effect the surface DOS.

If we are to explain the control of DOS in terms of acid mix composition it is important to understand how the discrepancies in the published data arose and to establish beyond doubt the behaviour of surface and bulk DOS with acid mix composition.

2.1.8 Quenching

Finally in this section a brief review of quenching and stablization procedures is presented, since it is important in view of the work contained in this chapter and Chapter 3 to understand how the different methods that can be employed might effect the final DOS of the cellulose nitrate. Industrially there are two important methods of nitration which differ most in the removal of the acid from the cellulose after nitration.

1 Mechanical Nitration

Nitration is carried out in large stainless steel containers with paddle stirrers on vertical shafts. The ratio of acid to cellulose employed is usually 45:1. Nitration times are typically 15 to 40 minutes. At the end of nitration the contents of the stainless steel vessel are dicharged into a large stainless steel centrifuge and the waste acid spun off. Care is taken to exclude atomspheric air to prevent any possible denitration. After spinning the nitrocotton still has about it's own wieght in acid adherent to it (mostly nitric acid). The cellulose nitrate is then drowned in a

jet of water. To prevent denitration by the ' diluted ' acid the drowning procedure is very rapid.

2 The 'Displacement Process'

Nitration is carried out in either earthenware or stainless steel vessels, the cellulose to acid ratio is lower than for mechanical nitration usually 1:30. After nitration the nitrating acid is displaced out of the bottom of the nitrating vessel by water coming in from above. It is suspected that during this process considerable denitration occurs at the fibre surface.

Cellulose nitrates undergo stabilization to remove residual acids (nitric and sulphuric), the oxidation products of nitration and sulphate esters, all of which are known to cause instability. Stabilization is usually a lengthy procedure involving 'boiling' or 'steaming' of the cellulose nitrate in water at atmospheric or under pressure (kiering). It is suspected that some denitration occurs during stabilization.

In Section 2.33 the effects of different quenching procedures and prolonged stabilization on the surface and bulk DOS are investigated.

2.2 Experimental

This section describes the basic procedures for the preparation and analysis of the nitrated and denitrated materials used throughout this work. In the following sections some of these procedures are discussed in more detail.

It is important to specify the source of raw cellulose and any pretreatment of the cellulose prior to nitration/denitration. Nitration is heterogeneous and in many heterogeneous reactions the effect of fibre structure on the extent of reaction achieved has shown to be very important, e.g. in the heterogeneous acetylation of cellulose.²³ Three sources of cellulose were employed in this work:-

(i) commercially produced, Holden Type II cotton linters. The original cotton of American origin was dewaxed and depectinised. A Shirley fluidity of 6.0 has been reported for the linters, which were vacuum dried at 60°C for two hours and stored over phosphorous pentoxide for several days before use. The water content of the linters was thus kept below < 2%,

(ii) cellulose woodpulp in the form of Whatman-1 cellulose papers,

(iii) cellophane sheets supplied by BCL cellophane. The cellophane was prepared by the viscose process. The film is without additives; impurities include: <10 ppm sodium; < 10ppm chloride and 50 ppm sulphur.

NITRATION • DENITRATION PROCEDURES

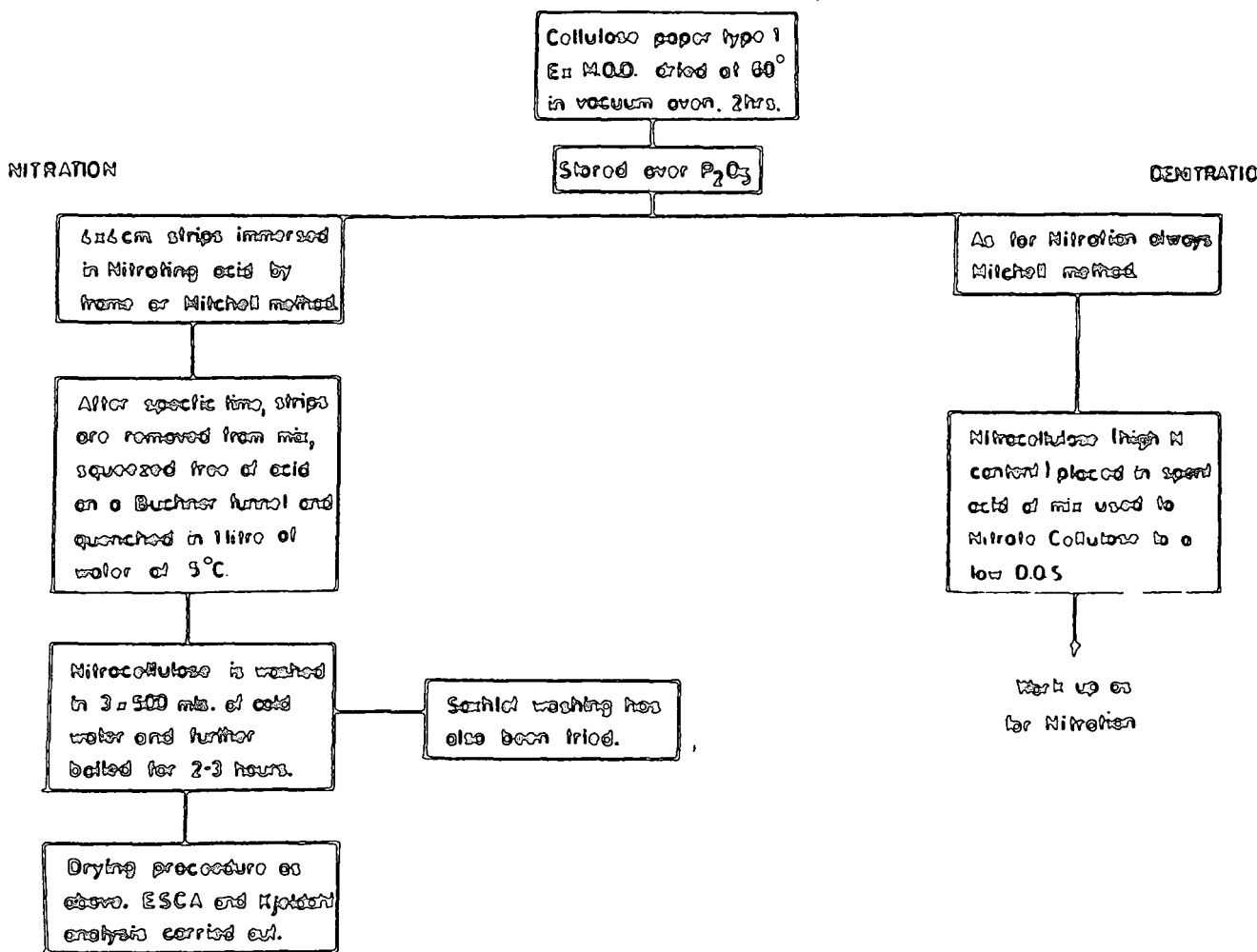

Figure 2.9 Schematic of the preparative methods of nitration and denitration.

The general procedure for nitration and denitration is indicated schematically in Figure 2.9. The preparation and DOS of the starting materials employed in denitration are described where relevant.

Bulk nitrogen determinations have been carried out by either modified micro-Kjeldahl analysis or by routine elemental analysis using a Carlo Erba Strumentazione Elemental Analyzer MoD 1106.

The ^{13}C nmr spectra were recorded on a Bruker AC 250 spectrometer, proton noise decoupled (62 MHz) with typical acquisition times of 9-12 hours; 10% by weight solutions of the polymer were made up in dimethylsulphoxide- d_6 ($d_6\text{dmsO}$): the materials were 'cooked' at about 70°C for several hours prior to running. The carbon shifts are reported with respect to the the internal tetramethylsilane (TMS) reference. Area ratios were determined from the analogue spectrometer outputs, peak fitting the curves on an Apple II micro-computer. The spectra were acquired at 75°C ; low temperature ($25\text{--}29^\circ\text{C}$) nmr have been reported but are characterised by broad linewidths and poor resolution²; high temperatures 80°C and above, as used by Wu¹⁵, gives discoloured solutions and additional peaks at long acquisition times.

The x-ray diffractometer employed was a Phillips P.W.1130 3kW x-ray generator incorporating a P.W.1050 diffractometer assembly (Cu tube operating at 40kV, 25mA). The recordings span from 4° in 2θ to 42° in 2θ and the mean $d(101)$ spacing is taken as the centre of the peak.

The ESCA spectra were recorded on a AEI ES200 Electron spectrometer and a customised Kratos ES300 Electron spectrometer, employing the Mg or Ti anode where specified. The operation and theory of the ESCA experiment is presented in Appendix 1.

2.3 Results and Discussion

2.3.1 Experimental Accuracy

The true significance of the reported discrepancies in surface DOS, Section 2.1.7, can not be assessed without first considering the limits of experimental accuracy, which can normally be worked to, in the production and analysis of cellulose nitrate. In particular, the reproducibility of the surface DOS monitored by ESCA has to be investigated.

Surface DOS can be calculated from Equation 1 once a suitable sensitivity factor is determined.

$$\text{DOS} = N_{1s}/C_{1s} \text{ core level areas} \times \text{s.f.} \times 6 \quad \text{Equation 1}$$

The sensitivity factor allows direct comparison of the elemental composition of a surface, relative to carbon.²⁹ The sensitivity factor can be calculated from theoretical considerations, see Appendix 1, or experimentally from model compounds. The experimentally determined sensitivity factors for a series of nitrogen containing model compounds are presented in Table 2.3. From this table it can be seen that there is good agreement in the determined sensitivity factors. A sensitivity factor for nitrogen to carbon of 0.74 for the samples analysed on the ES 300 has been employed throughout this thesis.

Table 2.4 presents the sensitivity factors for model nitrogen containing compounds, determined experimentally on the ES200. There are important changes in design feature between the two spectrometers, see appendix, and because of the difference in their design features it was considered appropriate to determine the sensitivity factor independently for both machines. A sensitivity factor of 0.73 is employed for samples analysed on the ES200.

Table 2.3 N_{1m}/C_{1m} Sensitivity Factors Determined from N containing Compounds on the ES300

<u>Compound</u>	<u>Sensitivity factor</u>
Nylon 6 cast from acetic acid	0.74
Nylon 66 commercially available film	0.74
Polymethylacrylonitrile- deposited in situ by cold probe method	0.76

Table 2.4 N_{1m}/C_{1m} Sensitivity Factors Determined from N containing Compounds on the ES200

<u>Compound</u>	<u>Sensitivity factor</u>
Nylon 6 cast from acetic acid	0.73
Nylon 66 commercially available film	0.73

Three cellulose nitrates were monitored on the two spectrometers and DOS calculated using the determined sensitivity factors, the results are displayed in Table 2.5. The cellulose nitrates were prepared from technical mixed acids.

Table 2.5 A Comparison of Surface DOS monitored on the ES200 and the ES 300 for three cellulose nitrates

Sample No.	Degree of Substitution	
	ES200	ES300
1	2.0	2.1
2	2.35	2.35
3	2.4	2.4

From Table 2.5 it can be seen that there is reasonable agreement in the surface DOS determined on the two spectrometers.

The variation in the DOS monitored for one batch of cellulose nitrate prepared in a technical acid mix is displayed in Table 2.6.

Table 2.6 The Reproducibility of Surface DOS as monitored by ESCA

Paper No.	Degree of Substitution
1	2.39
2	2.40
3	2.32
4	2.46
5	2.40

Table 2.6, 5 Cellulose papers nitrated for 2 hours at room temperature in a 65% H₂SO₄, 22.5% HNO₃, 12.5% H₂O mix. DOS determined on the ES300.

From Table 2.6 it can be seen that the variation in DOS determined by ESCA is accurate to 5%: the mean DOS is 2.39 and the standard deviation in DOS monitored is 0.03.

Wider variation in DOS from a single nitration has been observed in the course of this work. However, large variations in surface DOS are accompanied by substantial increases in the level of extraneous hydrocarbon monitored on the surface of the cellulose nitrate. The nitrogen sensitivity factor experimental determined (above) only applies to surfaces free from contamination;²⁹ a uniform layer of contamination over the surface will more seriously attenuate the signal from the N_{1s} core level than from the C_{1s} core level. This is a consequence of the different mean free paths through a polymer of the photoejected electrons from the C_{1s} and N_{1s} core levels; the effect of a uniform overlayer of various thickness on DOS can be mathematically modelled.³⁰ In fact most of the hydrocarbon contamination observed by ESCA does not sit on the cellulose surface but rather in the surface. This can be seen from Figure 2.10, where the DOS in (a) is unchanged after removing the contaminant, see (b). In (a) the hydrocarbon level is extremely high, over 40% of the C_{1s} envelope, after soxhlet extraction with petroleum ether and dichloromethane, both non-solvents of cellulose nitrate, much of the contamination is removed (b), i.e. the hydrocarbon peak is less than 20% of the C_{1s} envelope. Employing Overlayer Theory²⁹ the effect of uniform layers of different thickness on the DOS monitored can be calculated. Table 2.7 shows the effect of uniform overlayers of 5 Å and 10 Å on the DOS

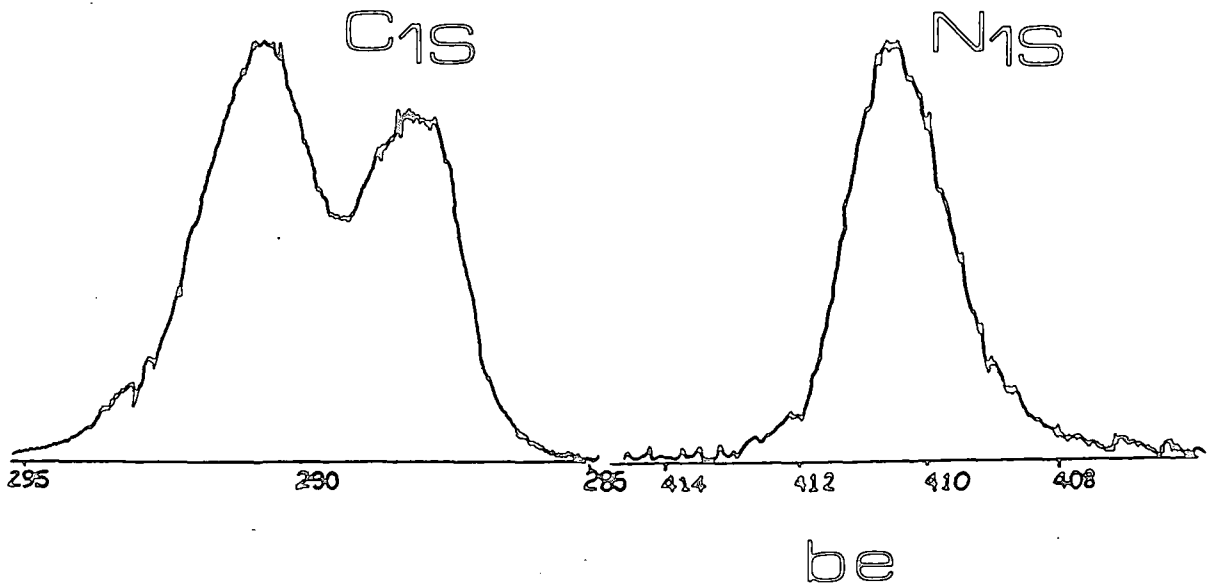

(a) Highly contaminated surface DOS = 2.5

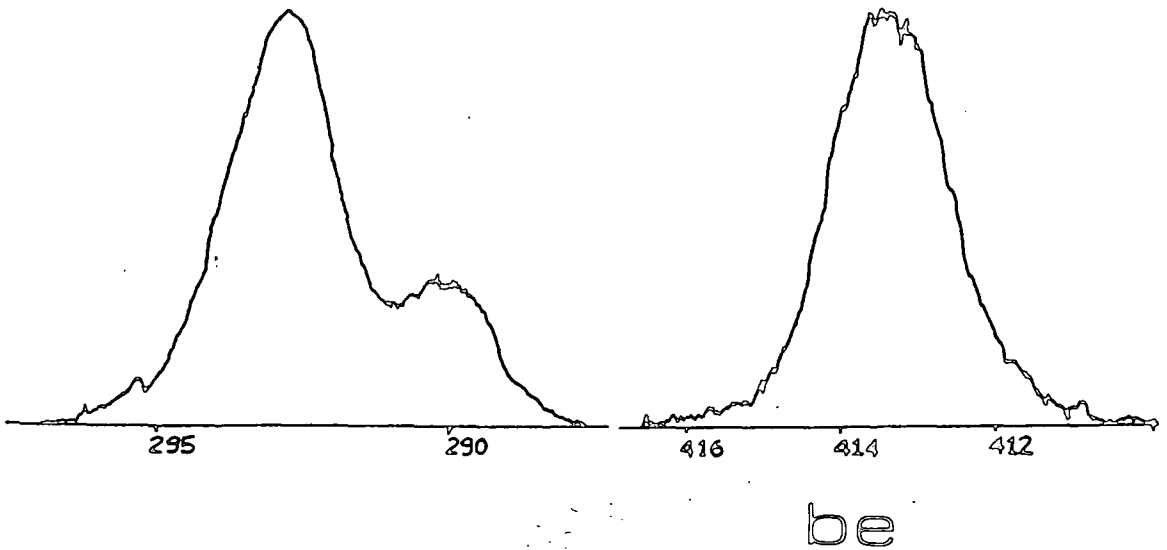

(b) C_{1s} and N_{1s} core levels after soxhlet extraction of (a) DOS = 2.45

Figure 2.10 The effect of surface contamination on DOS monitored

monitored by ESCA for 3 different DOS.

Table 2.7 The Effect of Contamination on DOS Monitored.

Overlay Thickness	Degree of Substitution			Hydrocarbon component of C_{1m} envelope
	3.0	2.5	2.0	
0A	3.0	2.5	2.0	0%
5A	2.5	2.1	1.7	35%
10A	2.3	1.9	1.5	60%

From the calculated values in Table 2.7 it is clear that a uniform overlayer which represents over 40% of the C_{1m} envelope will seriously attenuate the DOS monitored. In Figure 2.10 this is not the case, therefore it does not seem unreasonable to suggest that the contamination exists either as a patched overlayer or in the surface itself. This hypothesis is to some extent supported by examination of the effect of contamination on nitrocellophanes. In Figure 2.10 and, generally, throughout this thesis, the cellulose source employed is cellulose woodfibre in the form of papers. Cellophane is a smooth cellulose film, which crinkles slightly on nitration: any extraneous contamination must be limited to the film surface. Small amounts of contamination are found to seriously depress the DOS. In the course of this thesis any samples showing a greater than 25% hydrocarbon contamination (C_{1m} envelope) were discarded.

2.3.2 X-ray Stability of Cellulose Nitrate

Cellulose nitrates are well known to be unstable over long exposure times to u.v. radiation.³⁵ More recently the stability of cellulose nitrates to interrogation by soft x-rays has been investigated.⁷ Stephenson⁶ and Munro and Fowler^{2,7} have shown that although cellulose nitrates are stable to irradiation by Mg_{K α} x-rays over the timescale of the ESCA experiment, at longer exposure times decomposition is characterized by loss in the intensity of the nitrate peak and after 4 hours by the appearance of a peak at lower binding energy (401eV), presumably due to photoreduction of the nitrate ester. A wide range of different DOS cellulose nitrates have been monitored by Mg_{K α} x-rays. The Mg_{K α} x-ray source has been replaced by a Ti_{K α} x-ray source to study the stability of the materials to x-rays of higher energy.² Under the typical operating conditions of the Ti anode (234 watts) shorter exposure times were required before significant decomposition was observed. Fowler² has attributed photoreduction to the background radiation, the Bremsstrahlung. Monochromatization of the x-ray source is possible but so seriously reduces the intensity of the x-ray source that for most practical purposes the Bremsstrahlung is tolerated.

The aluminium window in the x-ray gun reduces irradiation of the sample by secondary electrons. The 'quality' of the window material also directly effects the total x-ray flux irradiating the sample (characteristic x-ray line + Bremsstrahlung).

Cellulose nitrates interrogated by $Mg_{K\alpha}$ x-rays during the course of this thesis were observed to be considerably less stable to $Mg_{K\alpha}$ x-rays than previously reported. This can be seen from Figure 2.11 (a) where a 2.3 (surface) DOS cellulose nitrate has been irradiated by $Mg_{K\alpha}$ x-rays and the N_{1s}/C_{1s} area ratios monitored are presented with exposure time. The rate of loss in the intensity of the signal from the nitrate ester is more dramatic than previously reported by either Fowler² or Stephenson⁵. Figure 2.11(b) shows the results obtained by Fowler for the irradiation of a similar DOS cellulose nitrate under the same conditions.

An induction period of only 2 hours was required before the appearance of the low binding energy component in the N_{1s} core level in (a), compared with the 4 hours previously reported by Fowler² and Stephenson.⁵

The changes in the N_{1s} core level are coupled with equally dramatic changes in the C_{1s} core level, see Figure 2.12. The level of extraneous hydrocarbon can be seen to rise sharply with exposure time, and this may in part account for some of the loss in signal from the N_{1s} core level; at higher binding energy the signal from the peak at 290.2eV (charge corrected 287.2eV) reduces with irradiation and there is growth in a 'new' peak at 292eV (289eV) assigned to the carboxylate functionality.² Similar changes in the C_{1s} core level have not previously been reported at such short exposure times.

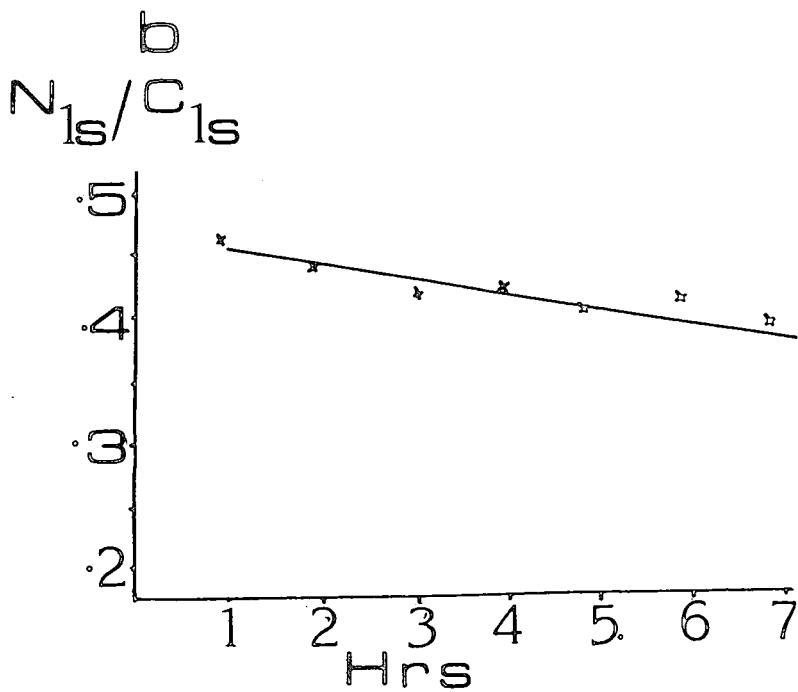
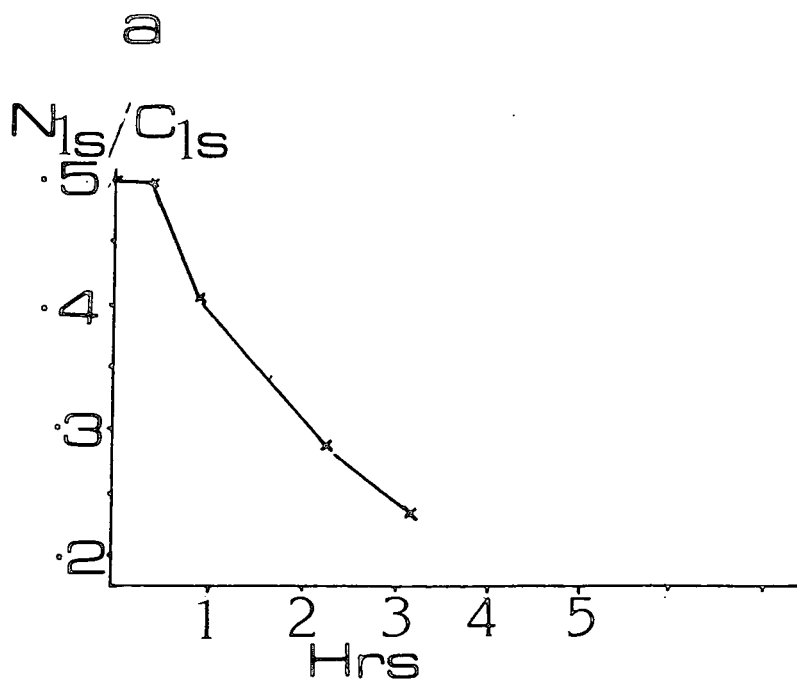

Figures 2.11 (a) and (b) N_{1s} and C_{1s} area ratios as a function of exposure time to $Mg_{K\alpha}$ x-rays

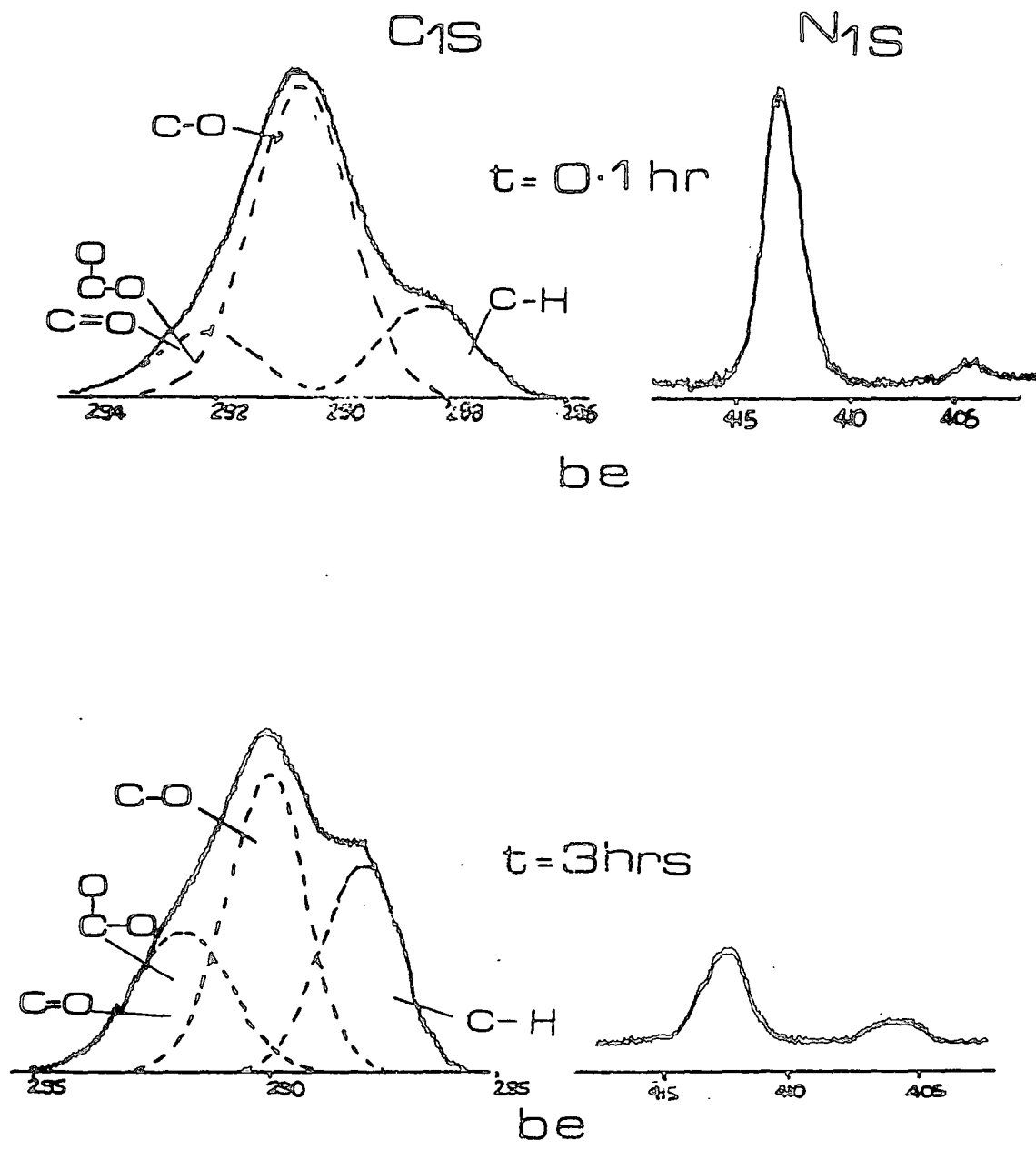

Figure 2.12 C_{1s} and N_{1s} core levels spectra as a function of exposure time

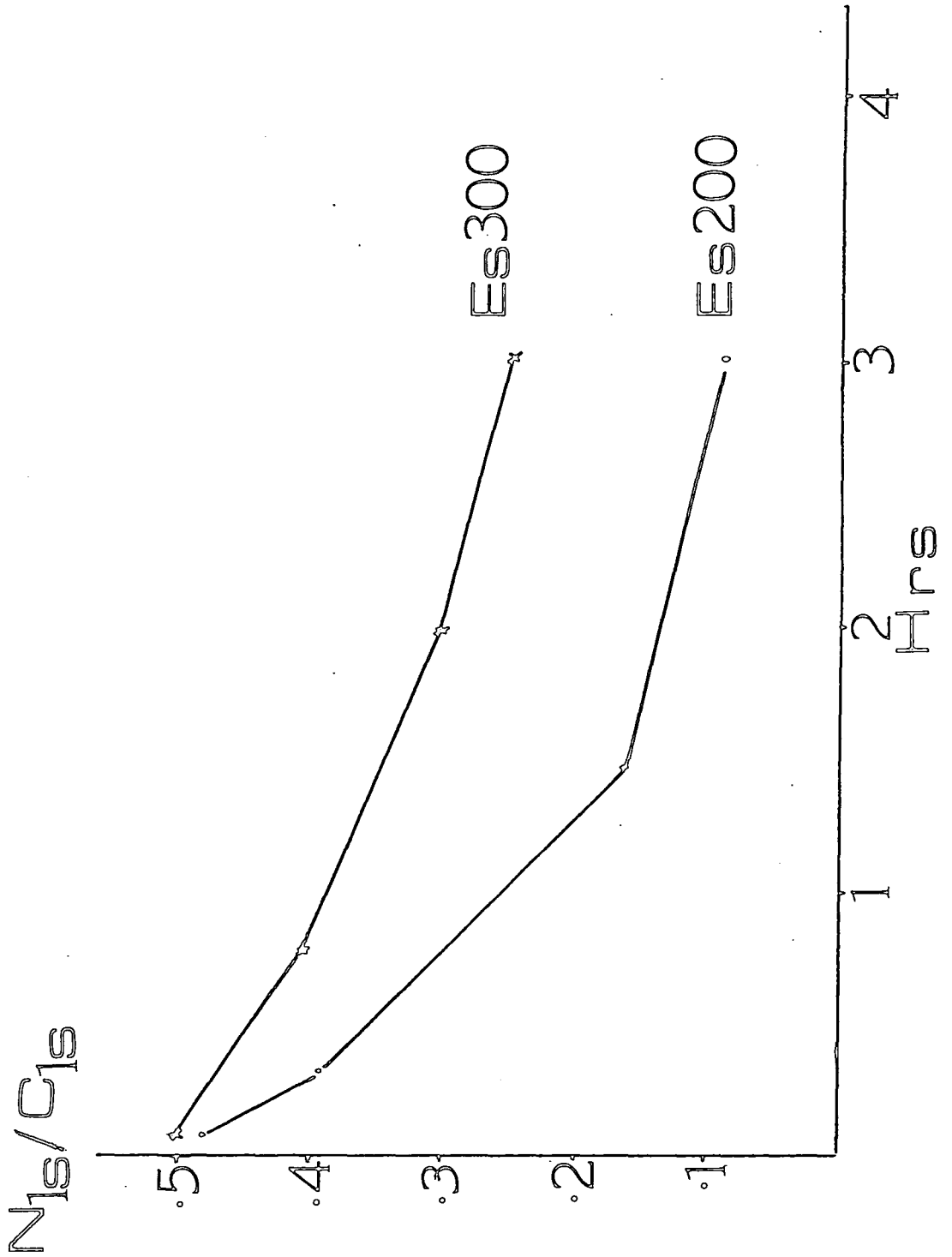

Figure 2.13 N_{1s}/C_{1s} area ratios as a function of exposure time on the ES300 and ES 200

In Figure 2.13 the N_{1s}/C_{1s} core level area ratios are compared for the exposure of a cellulose nitrate to $Mg_{K\alpha}$ x-rays with time, on two different Electron spectrometers. The differences in design features between the two spectrometers are discussed in the appendix. From Figure 2.13 it can be seen that different stabilities are displayed by the same material subjected to x-ray exposure 'presumably' under identical operating conditions. There is a much accelerated rate of photo-reduction observed for the sample analysed on the ES200; further, significant changes in the peak intensities in the C_{1s} core level are observed at much shorter exposure times. A slight rise in the temperature of the sample run on the ES200 was noted ($8^{\circ}C$). Munro and Fowler² have shown the effects of thermal degradation to be bulk orientated. Further, temperatures of $>100^{\circ}C$ are required before thermal degradation is evident; therefore in the above experiment it is assumed that the observed degradation results from irradiation with the $Mg_{K\alpha}$ x-rays.

The differences in the described rates of photo-reduction outlined above indicate that although the operating condition of the spectrometers are the same, the actual photon flux irradiating the sample is not. The distance of the x-ray gun from the sample is different in the two spectrometers and this is clearly an important factor when considering the total x-ray flux irradiating the sample. The x-ray dosage the sample surface receives is also modified by the window material in the x-ray gun: the quality of window material is dependent the uniformity

(i.e. how pinhole free it is) and the thickness of the film from which it is made. Replacement of the window, even with aluminium from the same sheet of foil, does not guarantee the same transmission characteristics. The materials in Figure 2.11 were run on the same spectrometer, but in the intervening time the window material had been changed. It is not unreasonable to assume that the variability of the window material in the Electron spectrometers employed, is the cause of the different stabilities observed.

2.3.3 A Study of the Techniques Employed for Bulk Analysis

Traditionally the method employed for the percentage nitrogen determination of cellulose nitrates is Kjeldahl analysis.^{36,37} During the course of this work Kjeldahl analysis has been employed, however the use this method has presented several problems:-

- (i) it is very time consuming,
- (ii) it is equipment consuming,
- (iii) it is difficult to carry out and therefore

frequently gives non-reproducible results, see below. Therefore the possibility of employing routine elemental analysis has been investigated. It was considered important that the C,H and N analysis of a cellulose nitrate using an elemental analyser gives:-

- (i) reproducible DOS values
- (ii) DOS values in close agreement with those obtained by Kjeldahl.

The reproducibility of the results from Elemental analysis were constantly tested throughout the three years

it took to compile this thesis. Every cellulose nitrate was analysed twice and the DOS calculated from the percentage carbon and nitrogen (by weight); the typical variation in DOS was found to be no more than 1% for cotton linters, but greater in other less pure celluloses. DOS values obtained from Elemental analysis were found to slightly greater than those obtained from Kjeldahl analysis, there are two reasons for this:-

(i) loss of nitrogen due either to incomplete digestion of the cellulose nitrate prior to steam distillation or, leaks at the ground glass joints during distillation,

(ii) the percentage nitrogen determined from Kjeldahl analysis is calculated from the moles of nitrogen, and the weight of the sample, see Appendix 2. However, cellulose nitrates contain 1-2%, by weight, of water.

2.3.4 A Study of the Quenching and Stabilization Procedures

The effect of quenching and stabilization procedures on the DOS have been investigated. It is generally believed that slow quenching procedures produce denitration at the fibre surface.²⁵ Cellulose nitrates are considered stable to boiling although some authors have reported that extended boiling can reduce DOS.

In Table 2.8 the effect of two different quenching techniques on the surface DOS are compared: the first where the acid is removed before quenching, the second where the cellulose nitrate is drowned in a thousand times excess of water, immediately after removal from the acid mix. When employing short nitration times, 1 second or so, it is

clearly impossible to remove the adhering acid from the cellulose nitrate prior to quenching, therefore it is important to establish that direct quenching does not effect surface DOS. From Table 2.8 it can be seen that the two methods produce cellulose nitrates of similar DOS.

Table 2.8 The Effect of Quenching Procedure on DOS

DOS	Quenching Procedure	
	Quench immediately 5 litres of water 5-10°C, boil	Buchner for a minute before quenching, quench, boil
	2.37	2.27

The effect of prolonged washing with tap water 6°C, no stabilization, on the surface DOS of 'green' cellulose nitrates prepared in a 75% H₂SO₄, 22.5% HNO₃, 2.5% H₂O acid mix is presented in Table 2.9.

Table 2.9 The Effect of Prolonged Washing on Surface DOS

<u>Wash Time (minutes)</u>	<u>DOS</u>	<u>S_{2P}/C_{1m} area ratio</u>
5 (in 1 litre H ₂ O	2.6	0.128
60 with stirring)	2.65	0.062
360 "	2.5	-
360 "	2.45	0.025
<u>900 "</u>	<u>2.4</u>	<u>0.025</u>
120 (under tap,	2.4	0.025
300 rapid flow)	2.35	0.025

From this table it can be seen that washing vigorously in fast flowing water causes a reduction in the surface DOS

monitored by ESCA. Washing in 1 litre of cold water effects the same reduction in DOS less rapidly. Since the N_{1s} core level in nitric acid appears at the same binding energy as the N_{1s} core level in the nitrate ester, it seems reasonable to consider that at least some, if not all, of this reduction in DOS is due to the washing out of residual nitric acid from the cellulose. Vigorous washing of the cellulose nitrate will reduce the surface DOS to 2.35, but no further. The amount of residual sulphur in the cellulose can be monitored from the S_{2p} core level. From Table 2.9 it is clear that washing reduces the level of sulphur monitored, but does not remove all the sulphur. The residual sulphur maybe present as either sulphuric acid or sulphate ester. This matter has received considerable attention. Smith²³ and others²⁴ have shown that in high DOS (bulk) materials that the sulphur is present as 'trapped' sulphuric acid and in materials of low DOS as sulphate ester.

From Figures 2.14 and 2.15 the effect of prolonged boiling, in distilled water, on the surface and bulk DOS of 2 cellulose nitrates can be seen. The cellulose nitrates were prepared in acid mixes of the composition:-

(i) 60% H_2SO_4 , 24.0% HNO_3 , 16.0% H_2O ,

(ii) 75% H_2SO_4 , 22.5% HNO_3 , 2.5% H_2O .

From these figures it is clear that prolonged boiling does not reduce DOS, surface or bulk. Only at very long stabilization times was a small decrease in DOS observed. Typical stabilization times employed in this thesis are in the order of 45 minutes (minimum) - 1.5 hours (average).

60% H₂SO₄, 24.0% HNO₃, 16.0% H₂O

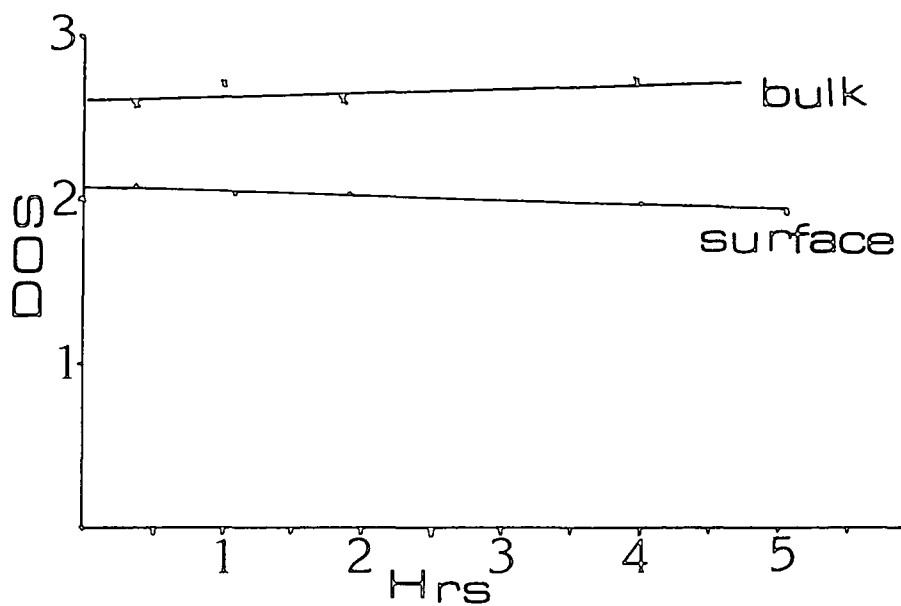

75% H₂SO₄, 22.5% HNO₃, 2.5% H₂O

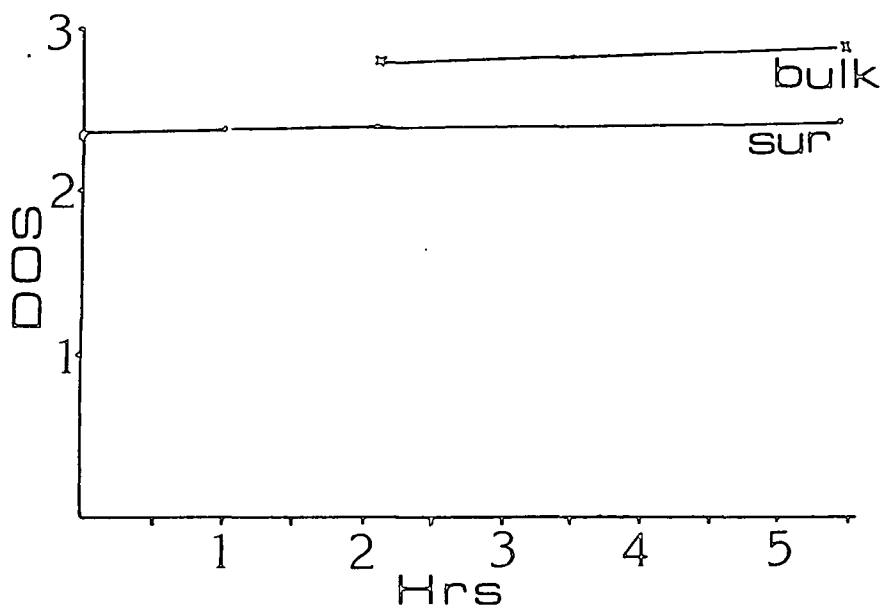

Figures 2.14 and 2.15 Effect of prolonged boiling on surface and bulk DOS

2.3.5. A Comparison of Surface and Bulk DOS

The discrepancies that exist in the published surface and bulk DOS values, for cellulose nitrates prepared from technical acid mixes, have been reviewed in Section 2.1.7. The results displayed in Table 2.10 illustrate the changes in surface and bulk DOS with different acid mix compositions for the nitration of Whatman papers. The surface and bulk DOS were monitored after 2 hours nitration at 20-22°C; the results displayed are the average of 4 or 5 measurements.

Table 2.10 Surface and Bulk DOS with Mix Composition.

Acid Mix	DOS		
	ES300	ES200	BULK
75% H_2SO_4 22.5% HNO_3 2.5% H_2O	2.3	2.25	2.65
70% H_2SO_4 22.5% HNO_3 7.5% H_2O	2.4	2.4	2.82
65% H_2SO_4 22.5% HNO_3 12.5% H_2O	2.35	-	2.78
60% H_2SO_4 22.5% HNO_3 17.5% H_2O	1.9	1.95	2.52
61.5% H_2SO_4 24% HNO_3 14.5% H_2O	2.0	-	2.64

It is important to note that the level of extraneous hydrocarbon observed in these samples was low. The highest level of hydrocarbon monitored in a sample was less than 23% of the C_{10} envelope; typically the level monitored was between 15-19% of the C_{10} envelope.

From Table 2.10 it can be seen that:-

(1) the surface and bulk DOS monitored are not the same for any of the nitrated celluloses,

(2) the DOS, surface and bulk, achieved is at a maximum in the 70% sulphuric acid mix.

The difference in surface DOS measured for nitration in the 65% and 70% sulphuric acid mixes is within the limits of experimental error. Again, the difference in bulk DOS measured for materials prepared in these 2 mixes cannot be considered significant.

There is good agreement between the surface DOS values presented in Table 2.10 and those reported by Stephenson for the same acid mixes, see Figure 2.8. The agreement in the actual bulk DOS values is not so good, but, the trend in bulk DOS with acid mix composition reported by Stephenson' is identical. The data presented in Table 2.10 does not support the trends in surface and bulk DOS, with acid mix composition, reported by Fowler.² However, from the results presented in Section 2.3.4 it is perhaps possible to appreciate how different surface DOS are obtained when different stabilization procedures are employed.

The variation in bulk DOS of the Whatman Papers was greater than expected, see Section 2.3.3. When the experiment was repeated replacing the papers by cotton linters and cellophane, different bulk DOS were obtained. In Chapter 3 this data is presented and the role of fibre structure in the control of DOS is considered.



ESCA of the Cellophane film

The C_{1s} and N_{1s} core levels of cellophane film were monitored by $Mg_{K\alpha}$ x-rays; the relevant spectra are presented in Figure 2.16. There is an appreciable improvement in the signal to noise in the spectra of the cellophane film (cf. fibres).

The purity of the cellophane film is important. In Figure 2.16 it can be seen that a moderately high level of hydrocarbon is monitored in the C_{1s} envelope of the cellophane film. By angular dependence studies the hydrocarbon can be shown to be limited to the cellophane surface, Table 2.11

Table 2.11 A Depth Profile of the Cellophane Film

Take off Angle	Depth from which 95% of signal originates	% hydrocarbon of C_{1s} envelope
20°	40 Å	15.4%
70°	15 Å	29.3%

Scraping of the cellophane surface with a clean scalpel blade dramatically reduces the level of surface contamination.

In Figure 2.16 a standard deconvolution of the C_{1s} envelope has been carried out. The area of the peaks at 286.9eV and 288.5 eV (charge corrected) are exactly in the ratio of 1:5, as would be anticipated from the empirical formula of cellulose.

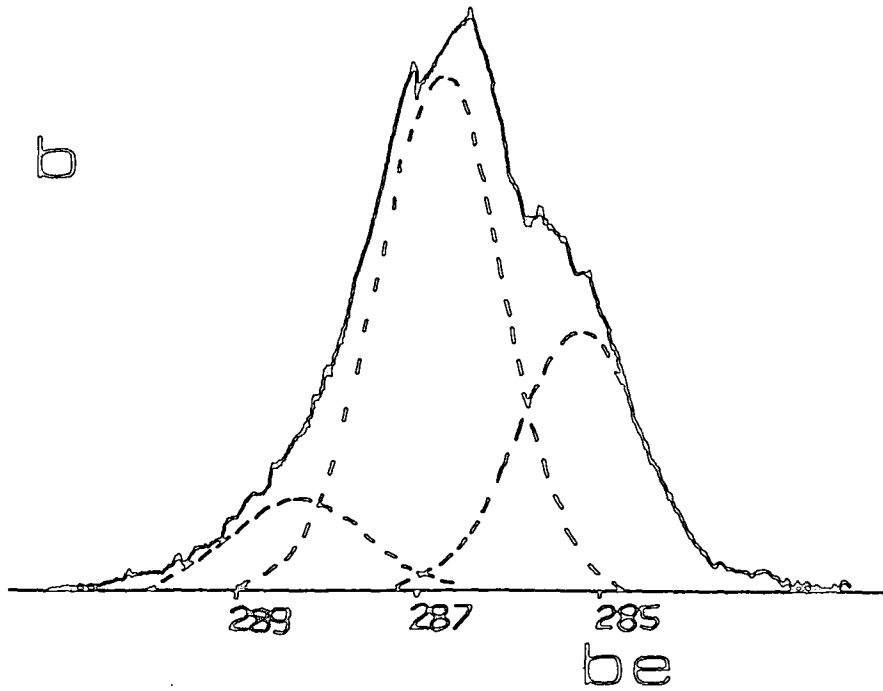
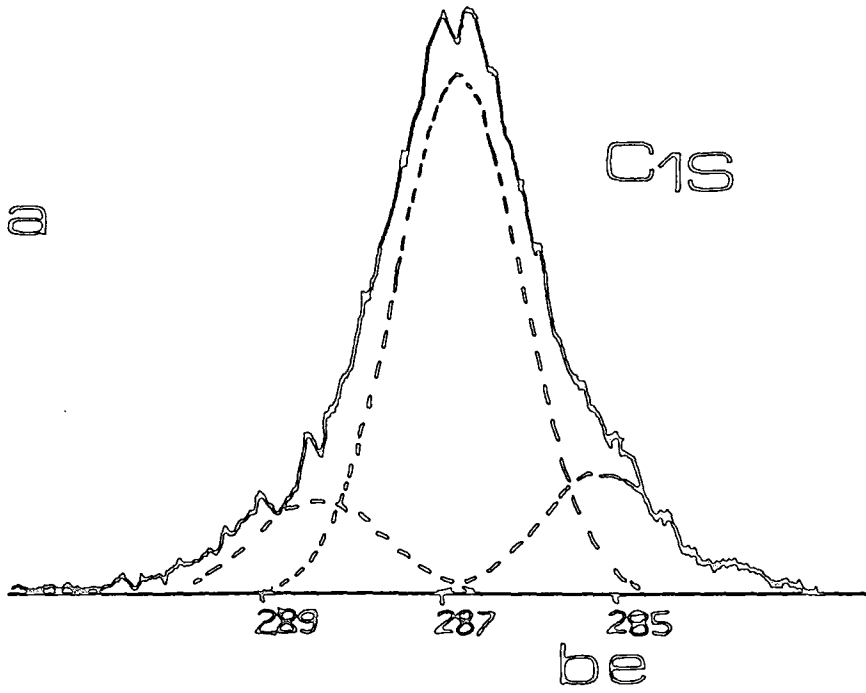

Figure 2.16 Typical ESCA spectrum of cellophane film (a) TOA = 20° (b) TOA = 70°

The Nitration of Cellophane

The C_{1s} and N_{1s} core levels of a cellophane sheet after nitration in a 60% H_2SO_4 , 22.5% HNO_3 , 17.5% H_2O mixed acid, are displayed in Figure 2.17. A considerable improvement in the signal to noise ratio in both core levels is obtained by the analysis of nitrocellophane, as opposed to nitrofibres. This improvement has made it possible to separate the C- ONO_2 and the C-OH peaks in the C_{1s} envelope. From the area under these two peaks the surface DOS of the material can be calculated as follows,

$$DOS = 3 \times (\text{area under C-}ONO_2 \text{ peak} / \text{area under C-OH peak})$$

The value obtained using this approach to calculate DOS, from the area ratios in Figure 2.17, gives a result which is in good agreement with the DOS calculated from the N_{1s} and C_{1s} core levels.

The relationship between surface and bulk DOS, with time, for nitration in a 65% H_2SO_4 , 22.5% HNO_3 , 12.5% H_2O mixed acid is displayed in Figure 2.18. From this figure it can be seen that the equilibrium DOS is established after 30 seconds in the surface region (top 30Å) and is comparable with that reported for the nitration of cellulose fibres in this composition acid mix. However, the rate at which the DOS is established in the surface region is appreciably slower than in the cellophane film.

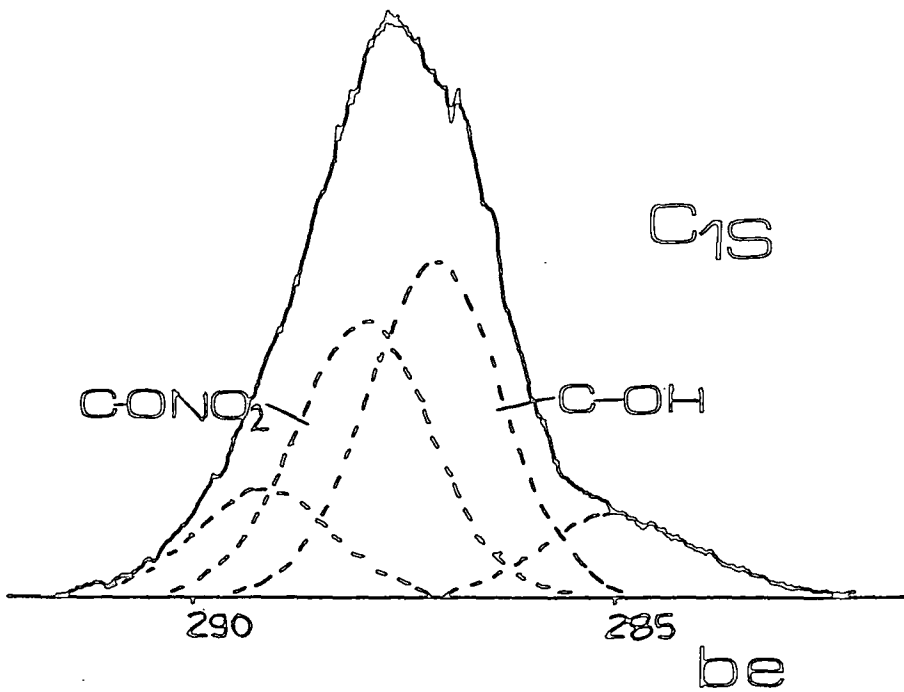
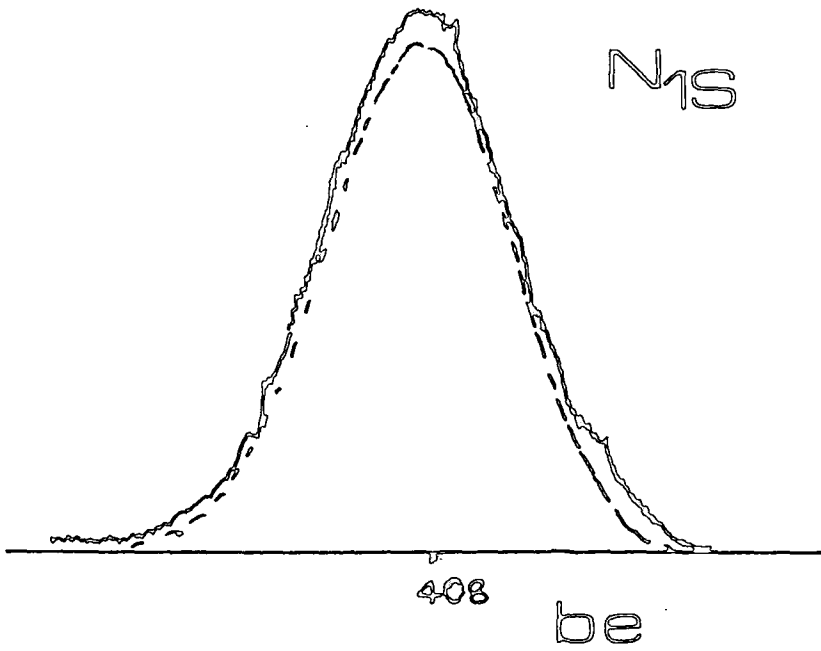
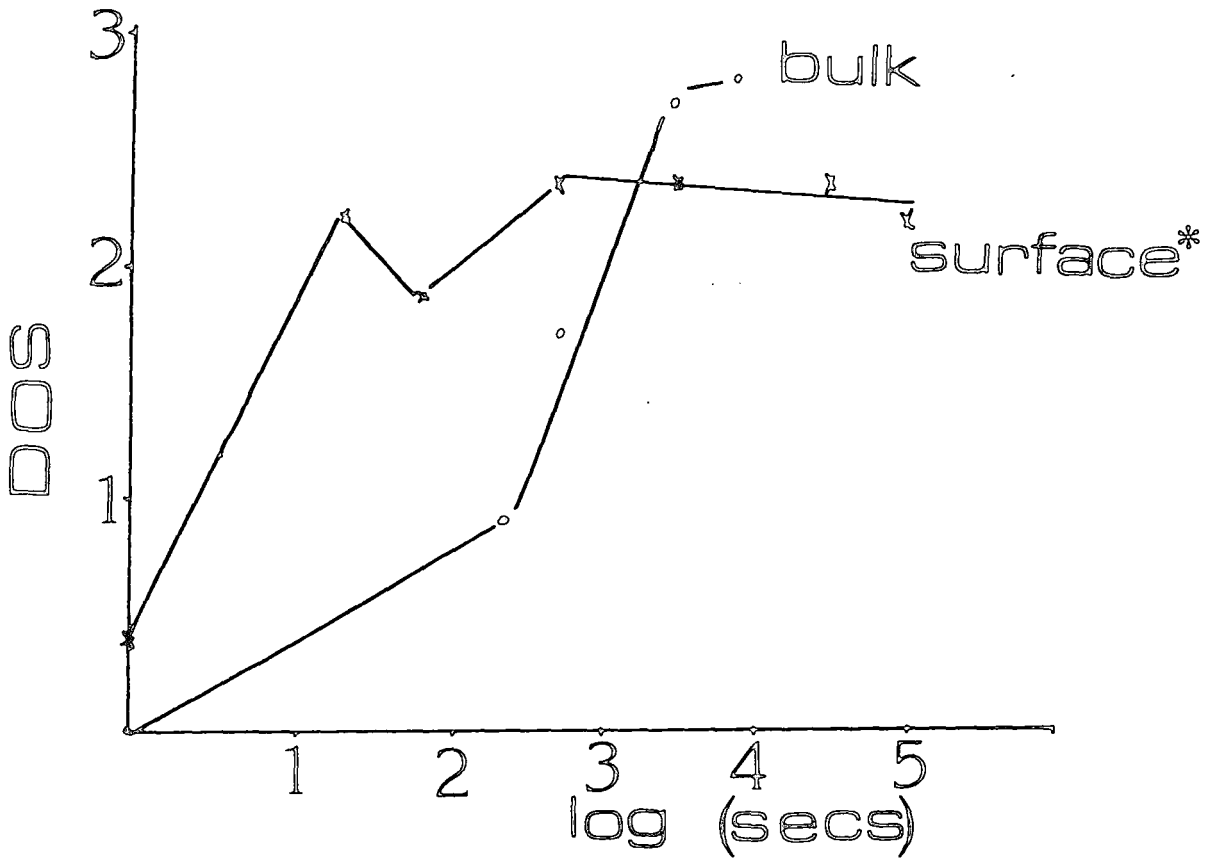

Figure 2.17 ESCA spectrum of a typical nitrocellulose

DOS from C_{1s} and N_{1s} core level areas = 1.41

DOS from C-OH / C-ONO₂ peak areas = 1.35



* TOA = 30° ES 300

Figure 2.18 Surface and bulk DOS as a function of time for the nitration of cellophane in a 65% H₂SO₄, 22.5% HNO₃, 12.5% H₂O mixed acid

By altering the angle between the sample and the analyser slits it is possible to obtain a depth profile an element's concentration in the surface region. This has been done for a 1 second nitrated material, Table 2.12.

Table 2.12 Depth Profile of DOS in Cellophane after 1 second

TOA	DOS
30°	0.33
70°	1.9

From Table 2.12 it is clear that the penetration of the nitrating acid mix into the cellophane film with time can be followed by ESCA. Further, the rate of penetration monitored in this study is considerably slower than that reported for mixed acids in cellulose fibres.

In Figure 2.18 there is an apparent dip in the surface DOS at 1 minute. At first sight this reduction in DOS appears contrary to the laws of mass action. However, ESCA is only monitoring changes in the elemental composition of the cellophane surface and not the overall level of nitration (DOS) of the material. The dip in DOS is a consequence of macro-changes in the cellophane surface at the onset of nitration.

The surface of a nitrating cellophane has been monitored by Scanning Electron Microscopy (SEM) and from Plates 1-5 it can be seen how the cellophane surface 'cracks' during nitration. The initial cellophane surface is smooth and even after 7 seconds nitration the film appears no different. However, by 30 seconds the surface is

criss-crossed by hair line cracks and the original plasticity of the film has been lost. It is almost certain that the cracking observed is responsible for the dip in DOS monitored by ESCA. In a variety of acid mixes the onset of cracking, at time t , can be correlated with a dip in DOS, see Chapter 4. The severity of the cracking observed and the change in surface DOS monitored can also be correlated. The cracking of the nitrated film presents a new un-nitrated surface. ESCA monitors both the nitrated surface and the new cellophane surface and hence the DOS monitored decreases. If the nitration time is extended the new cellophane surface nitrates. The completely nitrated material is still fairly brittle although it has regained some of the plasticity of the original cellophane film. Once the surface of the film has cracked it does not revert to a smooth film with complete nitration, see Plate 5. The cracking phenomena is further discussed in Chapter 4, where it is observed in cellulose fibres; an explanation for why the cracking occurs is also presented in Chapter 4.

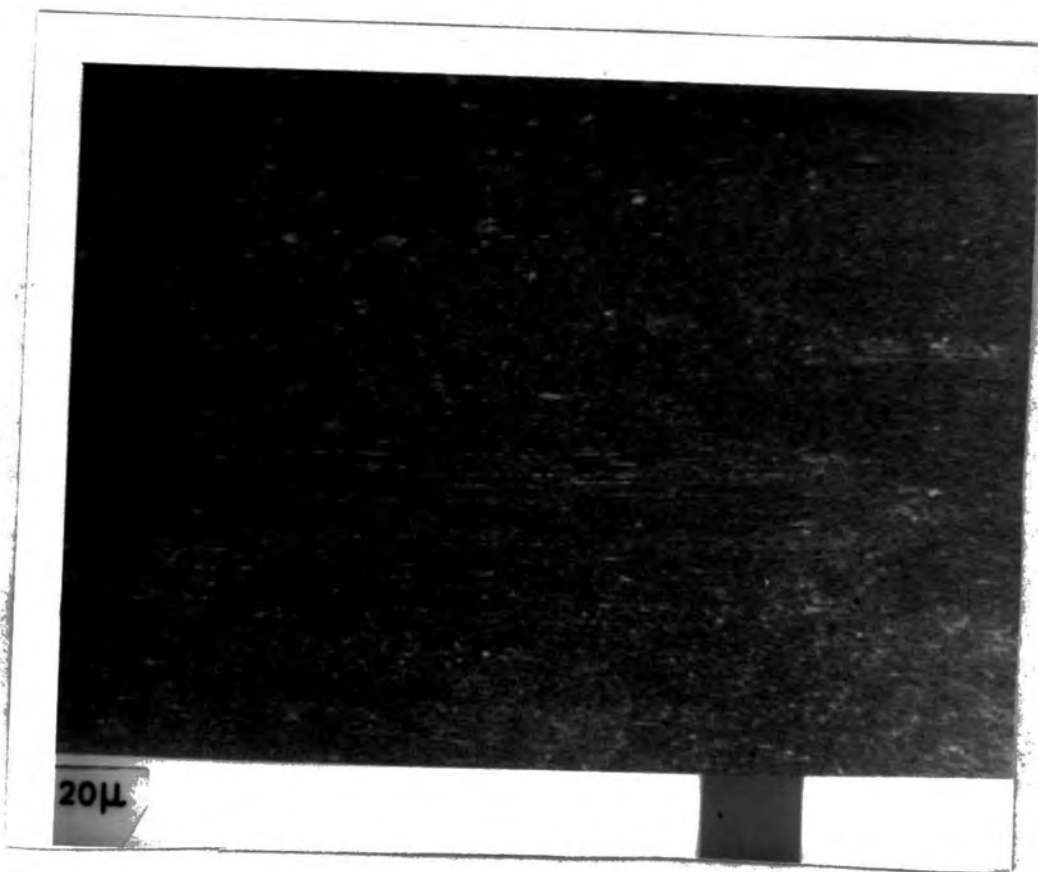

Cellophane

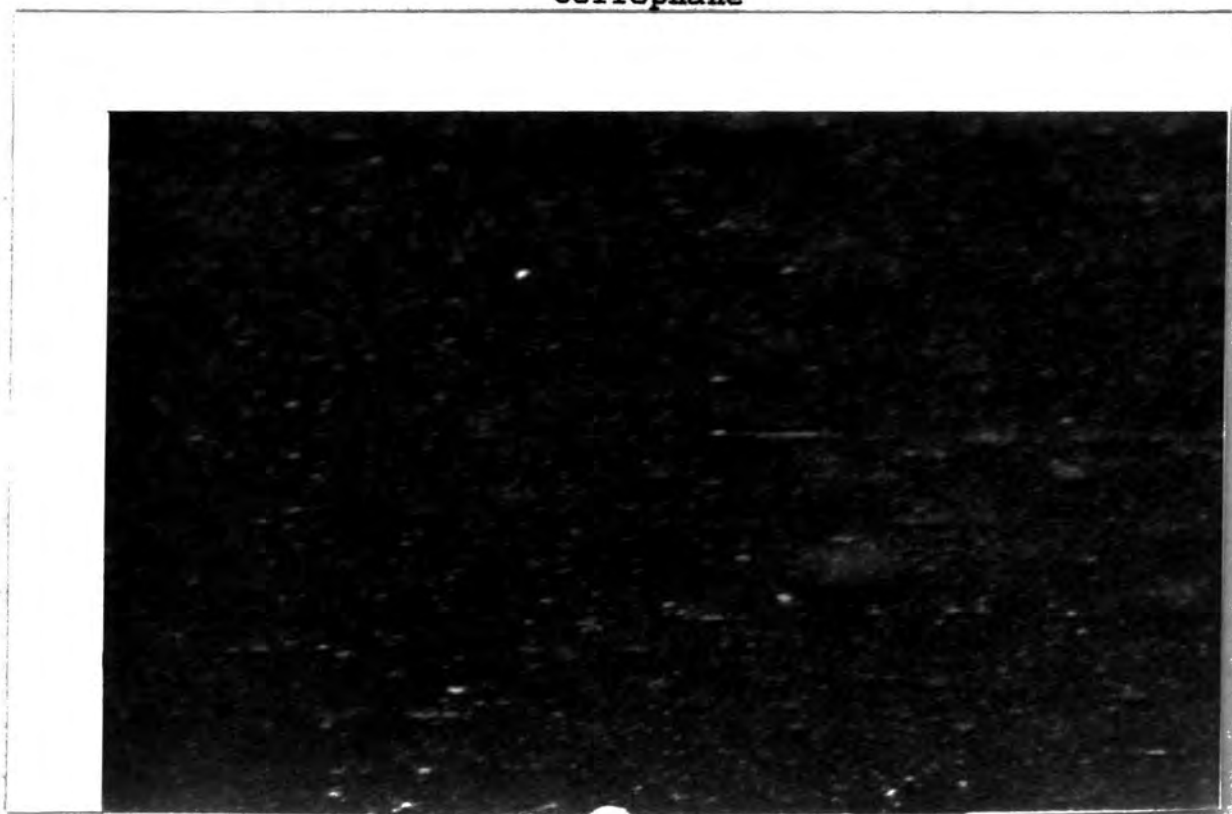

10μ

7 seconds nitration

Plates 1 and 2 Scanning electron micrographs of nitrated cellophanes

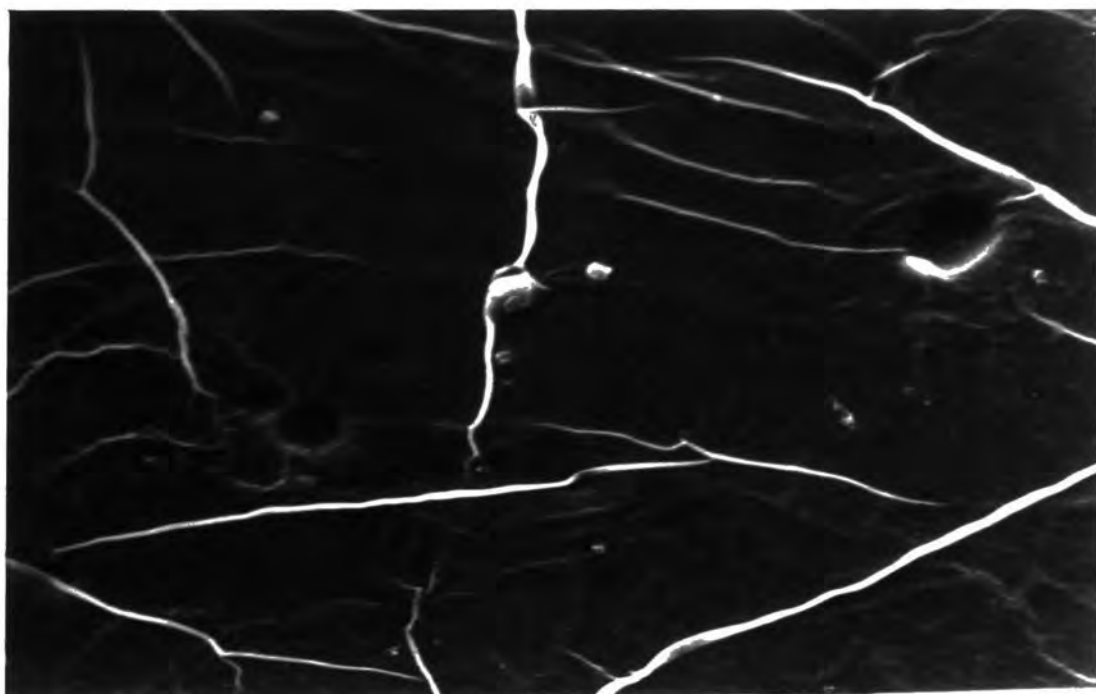

20 μ

30 seconds nitration

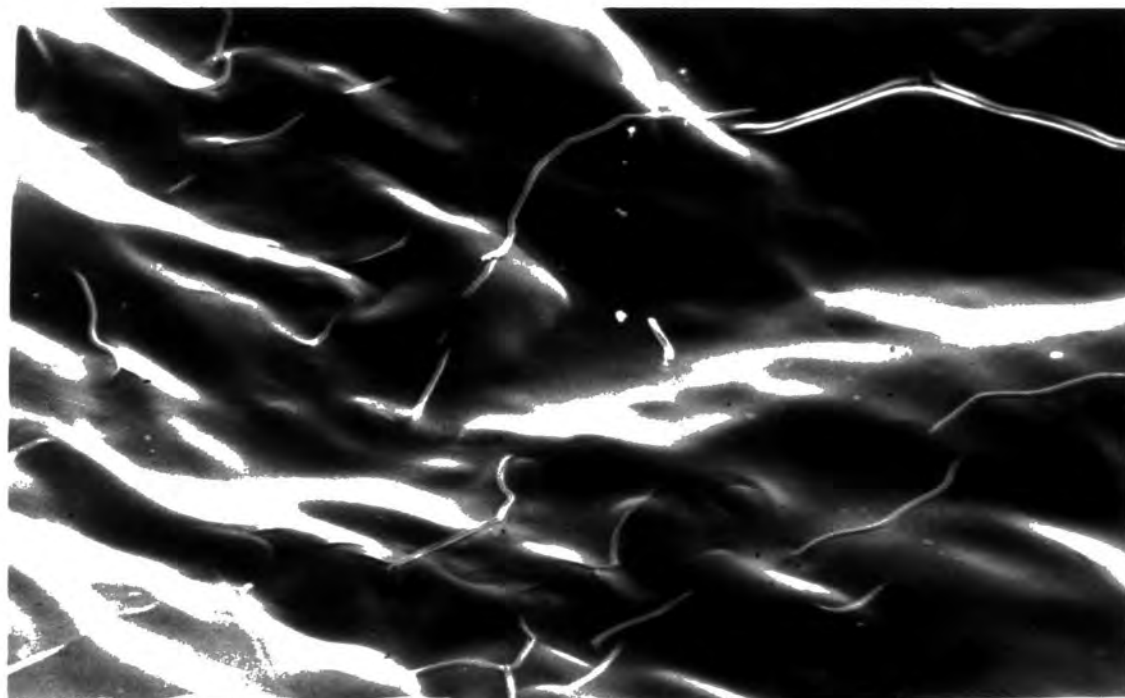

400 μ

10 minutes nitration

Plates 3 and 4 Nitrating cellophane

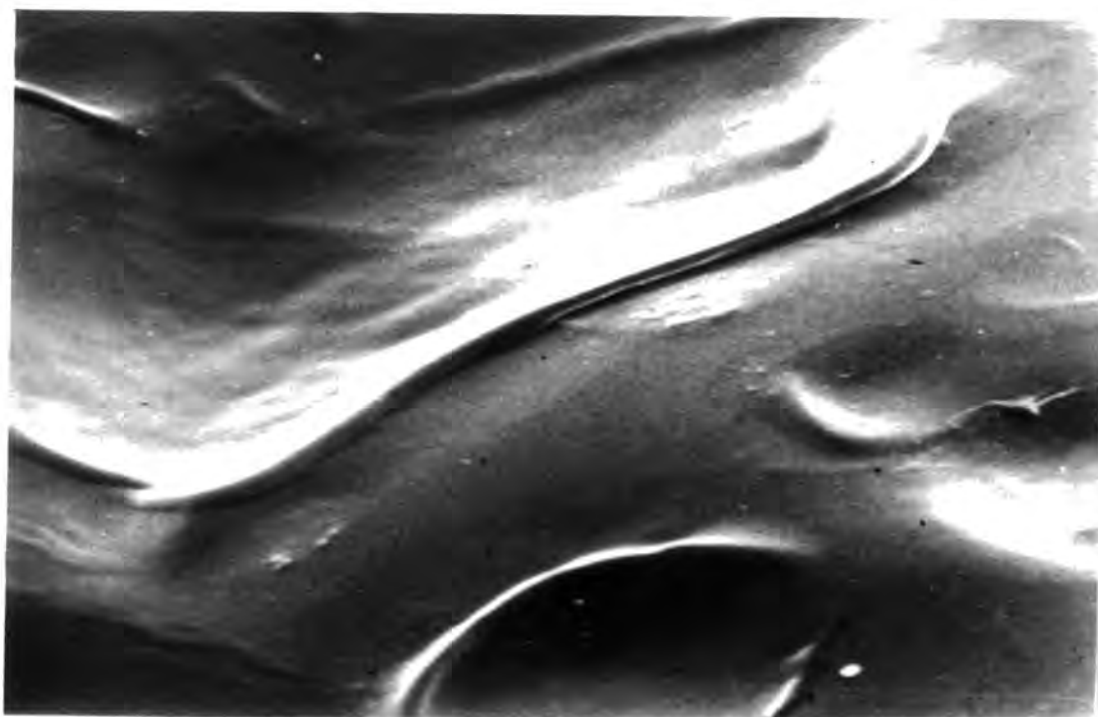

100 μ

Plate 5 SEM of a cellophane film after 40 minutes nitration

Figure 2.19 displays the variation of surface and bulk DOS, with time, for the nitration of cellophane in a 75% H_2SO_4 , 22.5% HNO_3 , 2.5% H_2O mixed acid. The above discussion relating to the nitration of cellophane in a 65% H_2SO_4 22.5% HNO_3 12.5% H_2O acid mix can equally be applied to the nitration of cellophane in this mix. From this figure it is evident that bulk nitration is very slow. This is probably a consequence of the reduced surface area of the cellophane films (cf. to papers).

Finally it is important to note the effect that hydrocarbon contamination can have on the surface DOS monitored for nitrated cellophane films. It has been shown earlier that high levels of contamination observed in

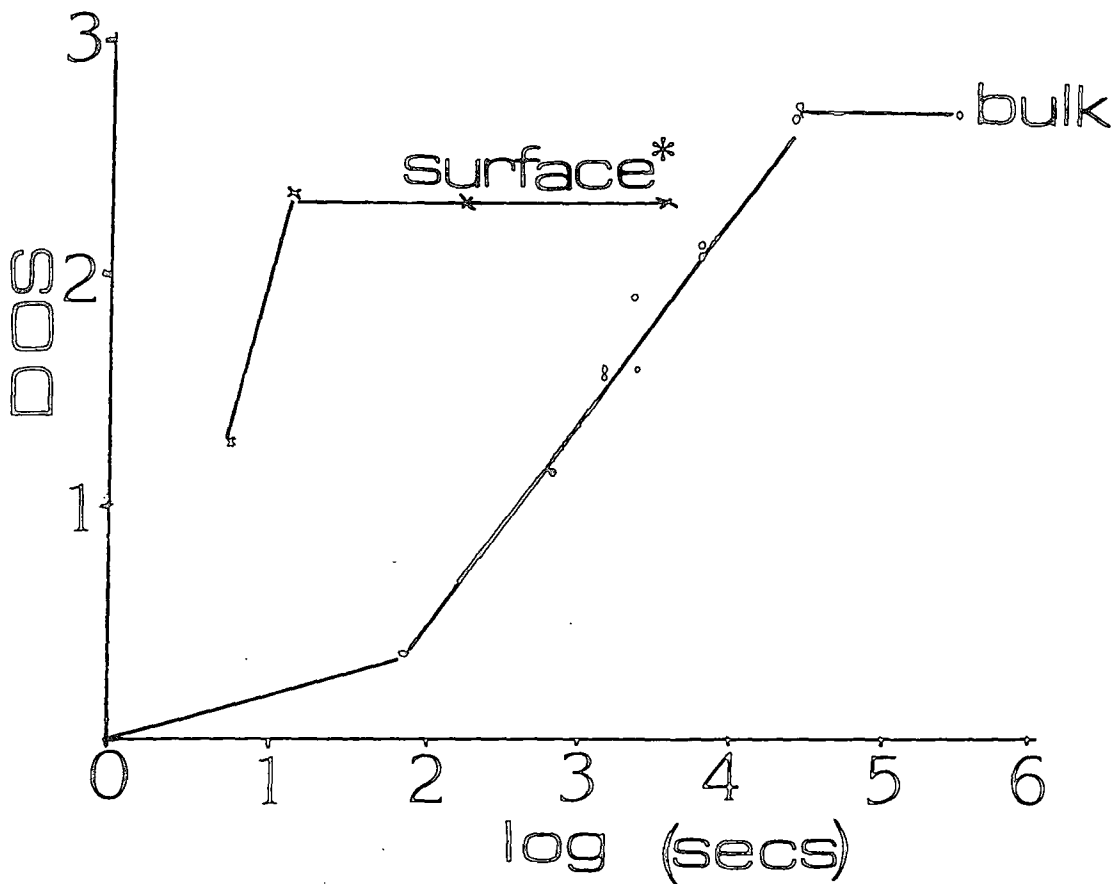

* TOA = 30 ES 200

Figure 2.19 Surface and bulk DQS for the nitration of cellophane in a 75% H₂SO₄, 22.5% HNO₃, 2.5% H₂O acid mix as a function of time

cellulose fibres do not seriously depress the DOS monitored. It is proposed that the contamination observed with cellulose fibres exists in the surface as well as on the surface and therefore up to 25% contamination of the C_{1s} core level is considered acceptable. However, with nitrated cellophane films, before or after cracking, this level of contamination is found to seriously depress the surface DOS monitored: the contamination is therefore considered to be 'on' the surface rather than 'in' the surface.

2.3.7 Summary

In this chapter the application of ESCA and ¹³C nmr to cellulose nitrate chemistry has been reviewed and it has been noted that serious discrepancies in the published ESCA data exist.

Aspects of experimental procedure were investigated to establish the accuracy and hence the significance of these differences reported in the ESCA data. The variation of surface and bulk DOS of nitrated Whatman papers with acid mix composition are reported. The trends in DOS observed with mix composition are the same as those reported previously by Stephenson.¹

The use of cellophane as an alternative source of cellulose to natural fibres, wood or cotton, has been investigated. There is considerable improvement in the signal to noise ratio in the ESCA spectra of cellophane sheets (compared to fibres). A cracking phenomenon is reported which occurs at the onset of nitration in the cellophane surface. This phenomenon has since been observed

in different celluloses and nitrating systems, see Chapters 4 and 5.

In Chapter 3 the differences in surface and bulk DOS reported are explained in terms of the acid mix composition and cellulose morphology.

REFERENCES

- 1 D.T. Clark, P.J. Stephenson, Polymer 1982, v23, 1034, .
- 2 A.H.K. Fowler, Ph.D. Thesis, University of Durham 1984, "Some aspects of the surface and bulk chemistry of cellulose nitrate as studied by ESCA and other spectroscopic techniques."
- 3 D.T. Clark, P.J. Stephenson and F. Healey Polymer, 1981, v22 1112.
- 4 D.T. Clark and P.J. Stephenson, 1981, v23 1295.
- 5 D.T. Clark, A.H.K. Fowler and J. Peeling Polymer Comm., 1983, v24, 117.
- 6 P.J. Stephenson, Ph.D. Thesis, University of Durham, 1981 "An investigation of cellulose nitrates and double based propellant by spectroscopic techniques".
- 7 A.H.K. Fowler and H.S. Munro, 1985, 13(1), 21.
- 8 A.H.K. Fowler, H.S. Munro and D.T. Clark, 255- 263, in "Cellulose and its derivatives" Eds. J.F. Kennedy, G.O. Phillips, D.J. Wedlock and P.A. Williams, Pub. Ellis Horwood Ltd, 1985.
- 9 D.T. Clark and A.H.K. Fowler, 1983, 24, 140.
- 10 A.H.K. Fowler, H.S. Munro and D.T. Clark, 345-371, in "Cellulose and its derivatives" Eds. J.F. Kennedy, G.O. Phillips, D.J. Wedlock and P.A. Williams, Pub. Ellis Horwood Ltd, 1985.
- 11 D.T. Clark and P.J. Stephenson, Polym. Degr. and Stab., 1982, 4(3), 185.
- 12 D.T. Clark, A.H.K. Fowler and P.J. Stephenson, J. Macromol. Sci.-Rev. Macromol. Chem. Phys., 1983, C23, 217.
- 13 A.S. Perkin and G.K. Hamer, Polymer Sci, Ch. Inst. of Canada 1979.
- 14 C.A. Fyfe, Solid State NMR for Chemists, CFC Press, Canada 1985.
- 15 T.K. Wu, Macromol, 1980, v13, 74.
- 16 J. Feast and H.S. Munro 'Polymer Surfaces and Interfaces', John Wiley, Chichester, 1987.
- 17 B. D. Ratner, S.C. Yoon and N.B. Meteo in ref. 16.
- 18 B. D. Ratner, T. Paynter, ACS Symp. Series, v162, Pub. ACS Washington DC 1987.
- 19 H.K. Yasuda, D.L. Cho and Y.S. Yeh in ref. 16.

- 20 H.K. Yasuda, K. Matsuzawa, Appl. Polym. Symp., 1984, No 38, 65.
- 21 D.T. Clark and A. Dilks, J Polym Sci Chem Ed, 1978, v16, 911.
- 22 D.T. Clark and A. Dilks J Polm Sci Chem Ed, 1979, v17, 957.
- 23 D.T. Clark in 'Polymer Surfaces', Eds. D.T. Clark and W.J. Feast, Wiley, Chichester, 1978.
- 24 A. Dilks, Ph.D. Thesis, University of Durham 1977 in 'The Application of ESCA to Structure, Bonding and Reactivity of some Polymer Systems'.
- 25 F.D. Miles in 'Cellulose Nitrate', Oliver and Boyd, London, 1955.
- 26 F.D. Miles and G.L. Wilson in ref 25.
- 27 H.S. Munro, unpublished data.
- 28 L.C. Wadsworth, D. Daponte in 'Cell Chem and its Applications', Eds. T.P. Nevells, S.H. Zeronian, Pub. Ellis Horwood, Chichester, 1985.
- 29 T.A. Carlson and G.E. McGuire, J. Elect. Spec., 1972, 1, 161.
- 30 C.S. Fadley, R.J. Baird and W. Siekhaus, J. Elect. Spec., 1974, 4, 93.
- 31 J.H. Schofield, Laurence Livermore Lab. Report, U.C.R.L.-51326, Jan. 1973.
- 32 J.J. Huang, J.W. Rabelais and F.O. Ellison, J. Elect Spec., 1975, 6, 85.
- 33 D.T. Clark and H.R. Thomas, J. Polym. Sci. Polym. Chem. Ed., 1977, 16, 2843.
- 34 D.R. Penn, J. Elect. Spec. and Rel. Phen. 1976, 9, 29.
- 35 B. Ranby, J.F. Rabek, 'Photodegradation, Photo-oxidation and Photostabilization of Polymers', Wiley Interscience, London, 1973.
- 36 P. Howard, Chem. and Ind., 1963, 1031.
- 37 P.L. Kirk, Anal. Chem., 1950, 22, 354.
- 38 A.C. Smith in according ref. 25.
- 39 S. Aravindanath, K.M. Paralikar, S.M. Betrabet and N.K. Chaudrai, Polymer, 1982, 23, 823.
- 40 J. Brasier, Material and Design, 1986, 7(2), 65.

CHAPTER THREE - A STUDY OF NITRATION IN MIXED
ACIDS

3.1.1 INTRODUCTION

Despite the proliferation of literature published pertaining to the nitration of cellulose with mixed acids, a clear picture of the reactions controlling DOS in mixed acids has yet to emerge. A major stumbling block to a more complete understanding of the nitration reaction is the uncertainty that surrounds the identity of the nitrating species. Unambiguous identification of this species would almost certainly shed new light on many of the features of nitration discussed in the previous chapters.

In Chapter 1 some of the older literature related to the nitration of cellulose in mixed acids was reviewed. From this review it is clear that up until the mid 1950's there was intense interest amongst chemists as to the identity of the species responsible for nitration. Popular opinion favoured 'free molecular' nitric acid as being the nitrating agent. The only other credible alternative proposed was the nitronium ion, NO_2^+ .^{3,4} However, Miles' in his comprehensive review of cellulose nitrate chemistry (1955) has ruled out the possible involvement of the nitronium ion, in the nitration of cellulose, in both mixed acids and nitric acid-water mixes. Summarizing, Miles has pointed out that :-

(i) the nitration of cotton occurs in nitric acid vapour where the existence of the nitronium ion is highly unlikely,

(ii) nitration takes place in mixed acids where the nitronium ion can not be spectroscopically detected.

The validity of both of these objections are closely examined in this thesis.

Recently the identity of the nitrating species in mixed acids has been re-investigated by Fowler.²² From a comparison of the surface DOS achieved, with the composition of the acid mix employed, Fowler has suggested that the nitronium ion is responsible for nitration. The acid mixes were examined by laser excited Raman spectroscopy. However, in Chapter 2 the surface DOS reported by Fowler were questioned.

In the late 1950's the kinetic studies of Ingold et al⁵⁻⁷ and others²³⁻²⁵ firmly established that the nitronium ion is the nitrating species in nearly all organic nitrations. However, the results of Ingold's work appear to have been largely overlooked by chemists when considering the identity of the nitrating agent of cellulose.²⁶

In Chapters 1 and 2 it has been argued that the nitration of cellulose in mixed acids is an equilibrium controlled reaction. The surface and bulk DOS reported in chapter 2 are not the same. It is thought that cellulose fibre structure plays an important role in determining the level of nitration achieved in the bulk material, although not as originally envisaged by Miles¹ and others,¹¹ see in Chapter 2. The bulk nitration of several different celluloses in a range of mixed acids are monitored and the DOS achieved in the different materials are correlated with the crystallinity of the celluloses.

In the course of this chapter Raman spectroscopy, solid state ^{13}C nmr and ESCA are employed to elucidate the identity of nitrating species and the mechanism controlling the DOS in mixed acids.

3.2.1 EXPERIMENTAL

The starting celluloses used in these studies and the experimental procedure employed for the preparation of cellulose nitrate with mixed acids have been described in Section 2.2.1.

The nitronium ion salt, $\text{NO}_2^+\text{BF}_4^-$, was dissolved in sulpholan (99% Aldrich Chemical Co.) and Whatman No. 1 papers were nitrated in a saturated salt solution for 5 minutes at 24°C. The nitration was effected under a dry nitrogen atmosphere (relative humidity 5-7%). Prior to analysis the papers were soxhlet extracted with hexane for two hours to remove any sulpholan adhering to the fibre surface.

The ^{13}C nmr (solid state) spectra of cellophane and Whatman No.1 papers were obtained on a Bruker CXP 200 operating at 200.13 MHz (proton) and 50.323 MHz (^{13}C) using a CP/MAS technique and a contact time of 1 ms. The rotor speed was approximately 3.2 kHz.

ESCA spectra were run on a Kratos ES300 electron spectrometer. All Raman Spectra presented in this thesis were obtained on a Varian Cary 82 spectrometer using an Argon gas laser (514.5nm, 200mW).

The experimental procedure employed for the sorption experiment is based on an experiment described elsewhere:¹² an outline of the modified procedure is presented with the relevant discussion.

RESULTS AND DISCUSSION

3.3.1 The Nitrating Species in Mixed Acids

In this section the identity of the nitrating species is investigated. It has been previously described how the C_{1s} and N_{1s} core levels can be used to determine the surface DOS of a cellulose nitrate monitored by ESCA. In Table 3.1 the surface DOS obtained for the nitration of Whatman papers in a range of mixed acids are presented. The nitric acid component in these mixes was kept constant at 22.5%, and the sulphuric acid to water ratio varied. The table shows that changes in acid mix composition affect the surface DOS obtained.

Table 3.1 Surface DOS with Acid Mix Composition.

	Acid Mix	DOS
Mix 4	75% H_2SO_4 , 22.5% HNO_3 , 2.5% H_2O	2.35
Mix 3	70% H_2SO_4 , 22.5% HNO_3 , 7.5% H_2O	2.40
Mix 2	65% H_2SO_4 , 22.5% HNO_3 , 12.5% H_2O	2.30
Mix 1	60% H_2SO_4 , 22.5% HNO_3 , 17.5% H_2O	1.90

Laser excited Raman spectroscopy was used to characterize these four mixes and three of these are displayed in Figures 3.1-3.3. The bands at 1400, 1320, 1050 and 966 cm^{-1} are assigned to the nitronium ion, nitric acid, the sulphate ion and sulphuric acid respectively.¹³⁻¹⁵ Comparison of the nitronium ion band intensity, 1400 cm^{-1} , with surface DOS reveals that, in general terms, DOS increases with increasing nitronium ion

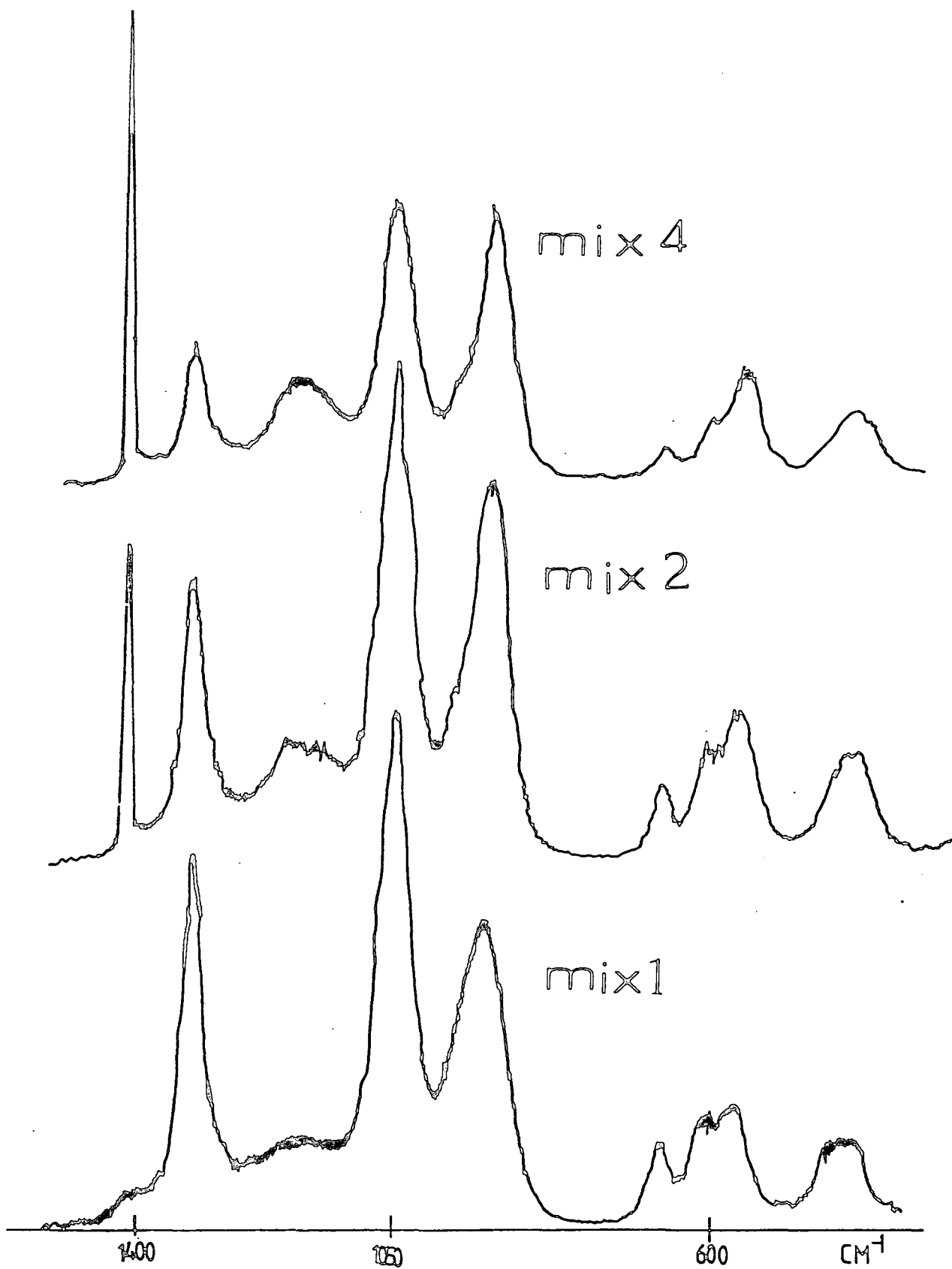

Figures 3.1 (top), 3.2 (middle) and 3.3 (bottom) Raman spectra of mixed acids

concentration. A similar experiment has been reported by Fowler.² The spectra presented in Figures 3.1 - 3.3 are very similar to those reported by Fowler for acid mixes of the same composition. However, the agreement in surface DOS is not as good (discussed in chapter 2). In a 75% H_2SO_4 , 22.5% HNO_3 , 2.5% H_2O mixed acid Fowler reports obtaining a surface DOS of 2.6, in Table 3.1 a DOS of about 2.3 is reported for this mix. Fowler's results led him to the conclusion that a linear relationship exists between the intensity of the nitronium ion band observed in the Raman spectra and surface DOS achieved. The data presented in Table 3.1 and Figures 3.1-3.3 does not support this conclusion. As discussed in Chapter 1, anhydrous mixed acids do not produce the highest bulk DOS cellulose nitrates and the results in Table 3.1 show that they do not produce the highest surface DOS either. However, if a relationship exists between the nitronium ion concentration and DOS it may well be obscured by other factors.

Potassium nitrate dissolved in sulphuric acid will react to give either the nitronium ion, nitric acid or the nitrate ion depending on the sulphuric acid concentration,²⁴ see Table 3.2. The nitrating ability of various nitrogen species in Table 3.2 were directly tested by immersed cellulose papers in appropriate potassium nitrate/sulphuric acid solutions.³⁵ The N_{1s} and C_{1s} core levels of the immersed celluloses were monitored by ESCA and the core level spectra are displayed in Figure 3.4. This experiment was first described by Fowler.²

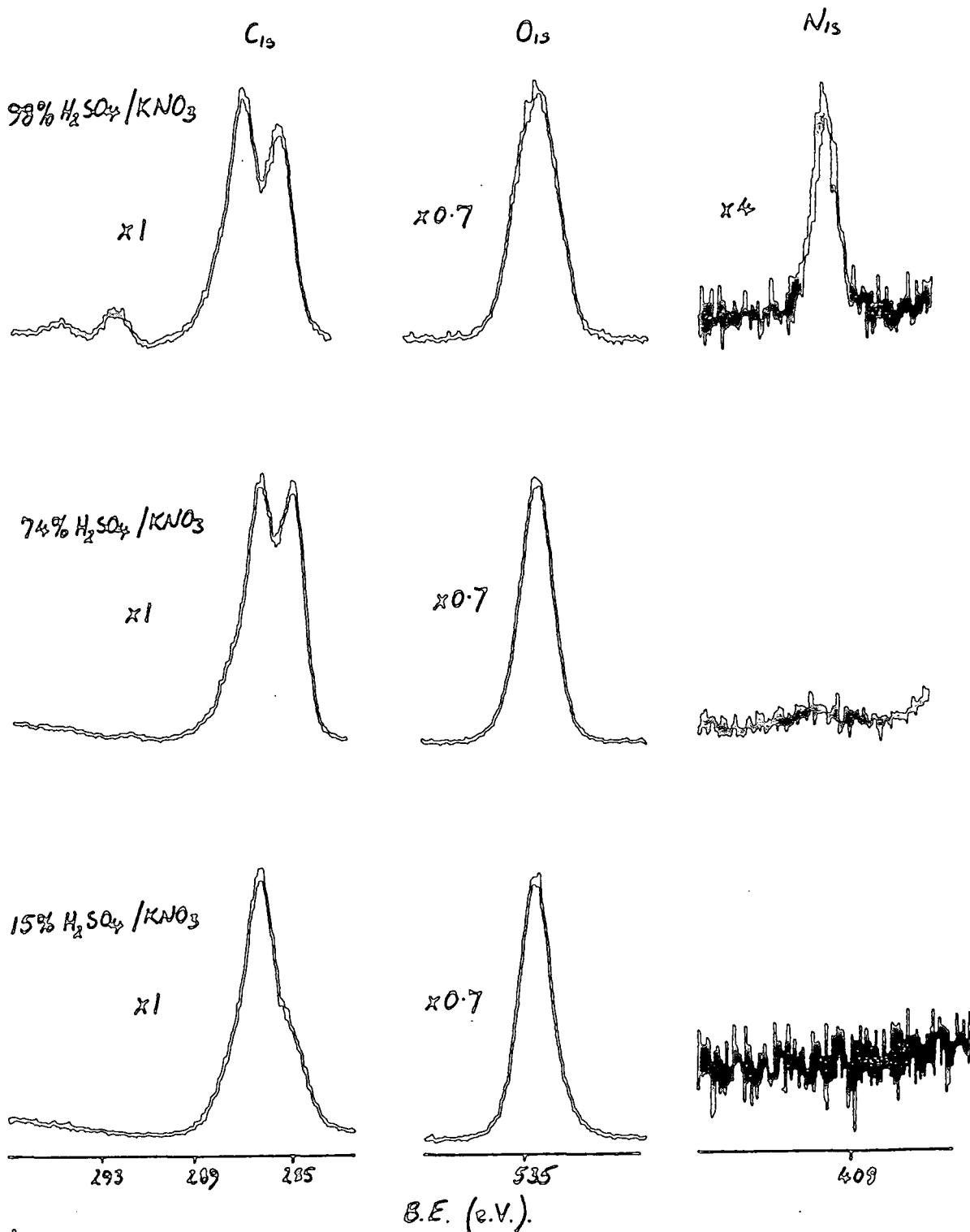

Figure 3.4 ~~Fig. 3.4~~ C_{1s} , O_{1s} and N_{1s} core level spectra for various concentrations of sulphuric acid with potassium nitrate

Table 3.2

% wt. H ₂ SO ₄	Species present
0-15%	NO ₃ ⁻
15-70%	NO ₃ ⁻ and HNO ₃
72-82%	HNO ₃
82-100%	NO ₂ ⁺

From the N_{1s} core levels it is evident that only in the 98% sulphuric acid solution has any nitration occurred, although the DOS achieved in this mix is very low (0.6). The Raman spectra of the potassium nitrate/sulphuric acid solutions are presented in Figure 3.5. Only in the 98% mix can the nitronium ion, at 1400 cm⁻¹, be spectroscopically detected.

The ability of the nitronium ion to nitrate cellulose was directly tested by the immersion of cellulose in a saturated nitronium ion salt solution. A piece of Whatman No.1 paper was immersed in a solution of nitronium tetrafluoroborate for five minutes. The surface of the treated cellulose was monitored by ESCA and the C_{1s} and N_{1s} core levels are presented in Figure 3.6. An intense signal is observed in the N_{1s} core level. The B_{1s} and F_{1s} core levels were also monitored but no signal was observed in either region after multiple scans and it is therefore considered that all the nitrogen observed is associated with the cellulose. After charge correcting the centre of the N_{1s} core level peak is at 408 eV,

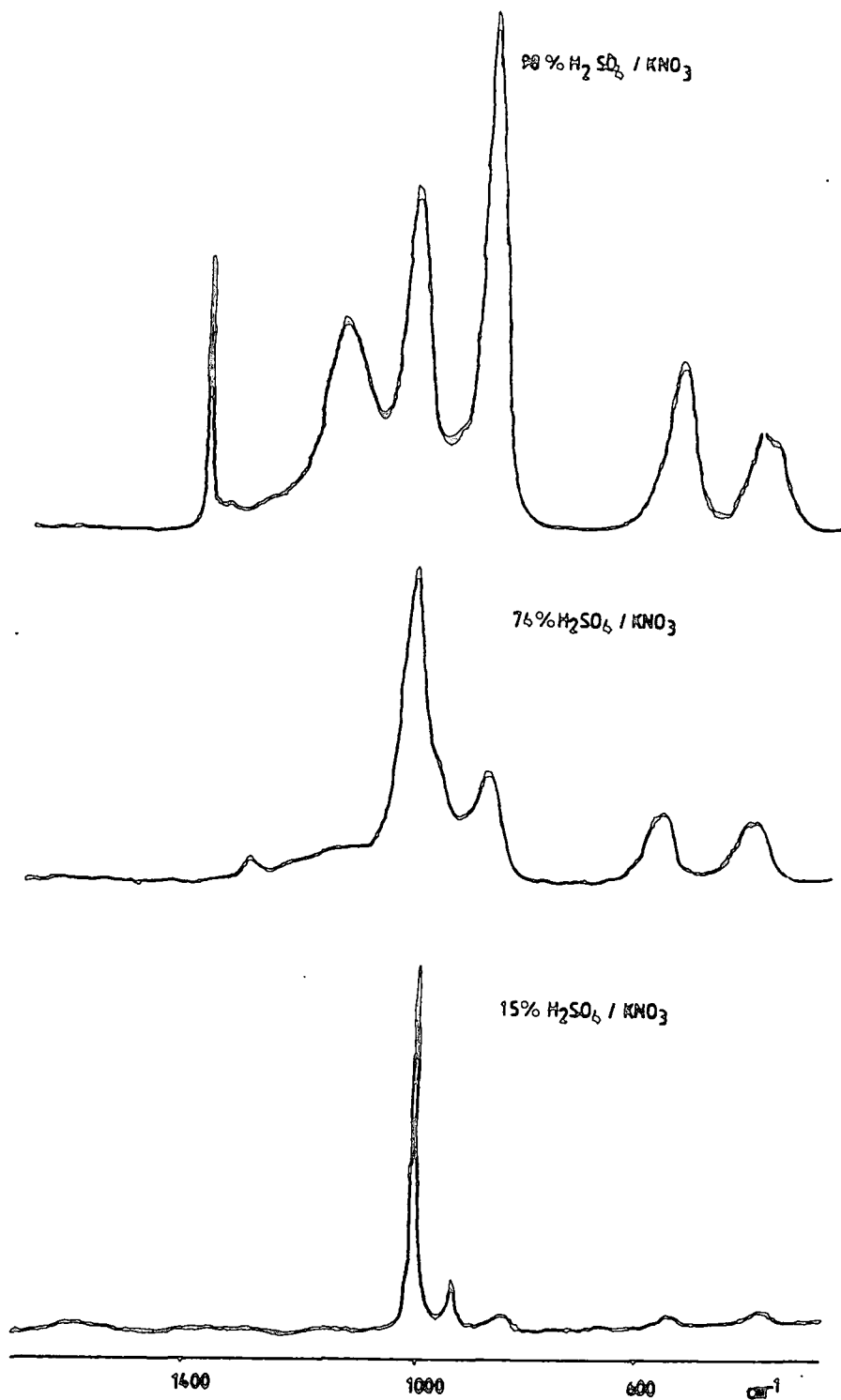

Figure 3.5 Raman spectra for the various concentrations of sulphuric acid with potassium nitrate

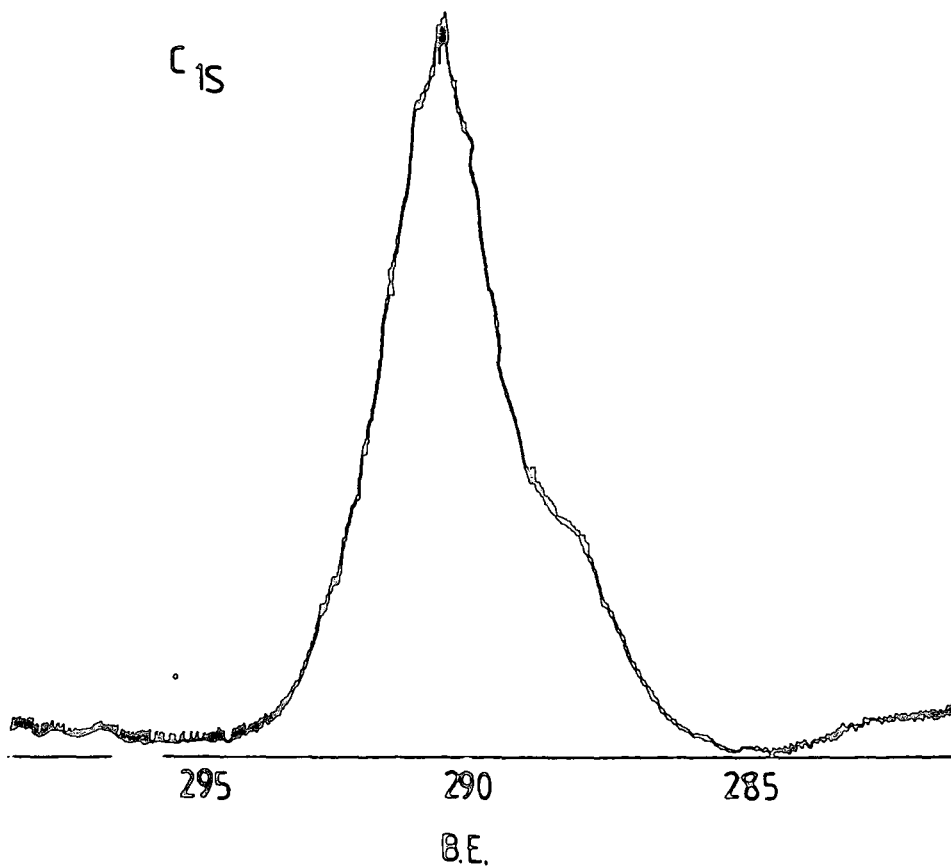
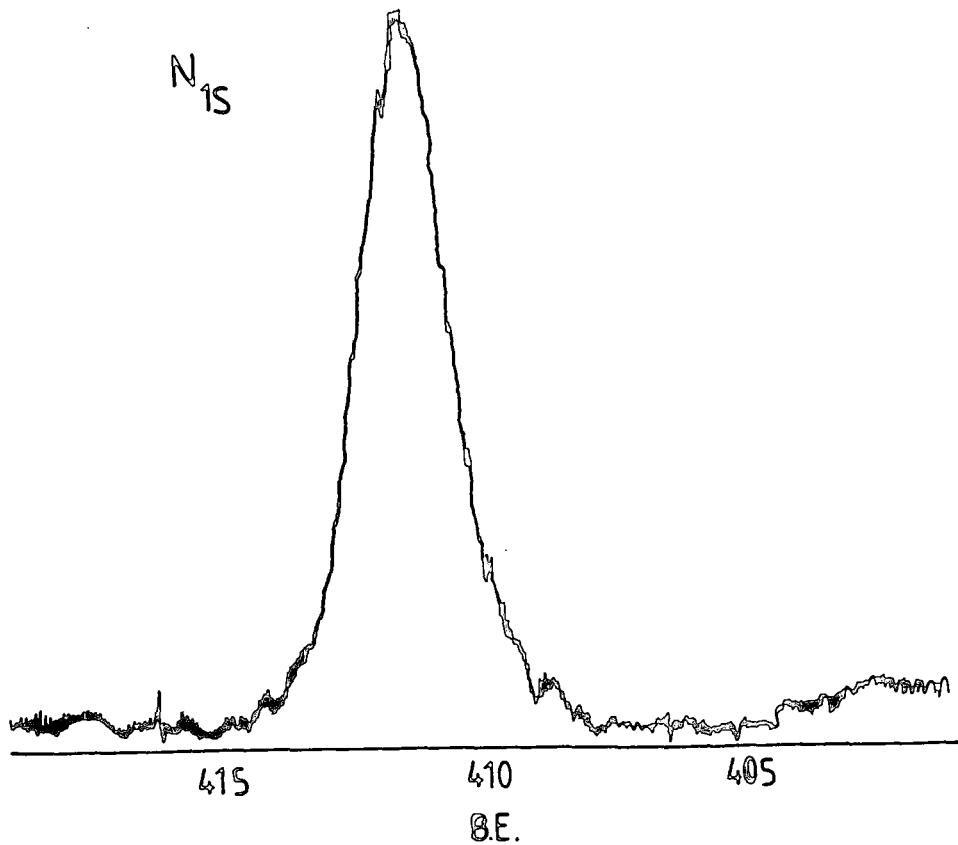

Figure 3.6 Core level spectra for cellulose nitrated in a nitronium ion salt solution (not corrected for sample charging)

indicative of the nitrate ester.

From this result it is clear that the nitronium ion can effectively nitrate cellulose. The surface DOS of the material in Figure 3.6 is 2.82 which is very close to the theoretical maximum of 3. The further use of the nitronium ion salts to nitrate cellulose are discussed in Chapter 5.

In Table 3.1 the surface DOS is at a maximum in the 70 % sulphuric acid mix (mix 3). However, from the Raman spectra it is known that the nitronium ion concentration is at a maximum in the nearly anhydrous mix 4. This mix can be made entirely anhydrous by replacing the sulphuric acid component with oleum. However, when nitrating in an equivalent oleum-nitric acid mix the surface DOS achieved is only 2.1. The Raman scan of this mix reveals almost complete ionization of the nitric acid. If the nitronium ion is responsible for nitration in mixed acids it is to be expected that the greater the nitronium ion concentration in an acid mix the higher the surface DOS obtained. From Table 3.1 it is clear that this is not the case and the possibility that some other process is preventing complete nitration in the fibre surface has been investigated. Two possibilities were considered:-

(1) competitive sulphonation is preventing complete nitration in the surface region,

(2) the denitrating action of sulphuric acid at high concentration is limiting nitration at the surface.

The effect of competitive sulphonation on DOS is considered first.

Clark and Stephenson' have explained the changes in the surface DOS achieved, with acid mix employed, in terms of the competitive nitration-denitration-sulphonation reactions. Trommel¹⁰ has gone further and proposed that one of the reasons why the maximum DOS in cellulose cannot be achieved by nitrating in mixed acids is because sulphonation blocks hydroxyl sites to nitration.

The level of sulphur in the surface of the materials prepared from mixes 1 and 4, Table 3.1, has been monitored. The materials were well washed (<6°C) but not boiled. It is thought that this procedure removes any adhering acid but does not hydrolyse sulphate esters.²³ The results are presented in Table 3.3.

Table 3.3

	<u>Degree of Substitution</u>	
	<u>ONO₂</u>	<u>OSO₃H</u>
Mix 1	1.9	0.04
Mix 4	2.35	0.08

Addition of the DOS, nitrate + sulphate, does not give a total DOS of 3 for 'nitration' in either mix. Clearly sulphate ester formation does not explain why a surface DOS of 3 is not achieved by nitration in mixed acids.

The level of sulphonation is greatest in mix 4; this result is in agreement with what Clark and Stephenson have reported.'

The possibility that denitration by the sulphuric acid component in mix 4 is responsible for the lower than expected DOS has been investigated.

Miles' has claimed that the denitration of cellulose nitrate in sulphuric acid is not possible. However, the limit on Miles's observation is that in very concentrated sulphuric acid solutions (<68%) the cellulose nitrate employed is irretrievably destroyed. Therefore, the observation of denitration in more concentrated acids using bulk techniques is not feasible. By utilizing the surface sensitivity of ESCA and the heterogeneous nature of the reaction, it is possible to observe (by appreciably reducing the reaction time) that denitration at the cellulose nitrate surface does indeed occur when the sulphuric acid content (relative to water) is greater than 80 %. This can be seen in Figures 3.7 and 3.8 where a cellulose nitrate, surface DOS of 2.4, has been immersed in an 80% sulphuric acid-20% water mix for 2 minutes at 26°C. From inspection of the N_{1s} core levels it can be seen that extreme denitration has taken place. Although cellulose nitrates are relatively stable to treatment with strong acids, cellulose is not. Strong mineral acids, for example sulphuric acid, phosphoric acid and hydrochloric acid, within definite solution ranges act as swelling or dissolving agents for cellulose.¹⁷ However, sulphuric acid and hydrochloric acid are definitely not true solvents as they are very reactive towards the cellulose chains and hydrolysis

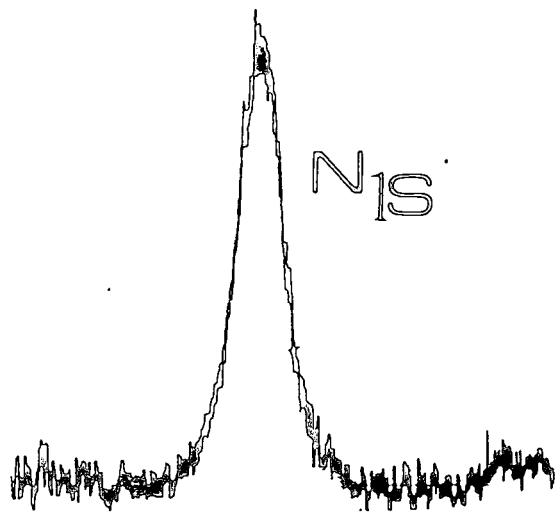
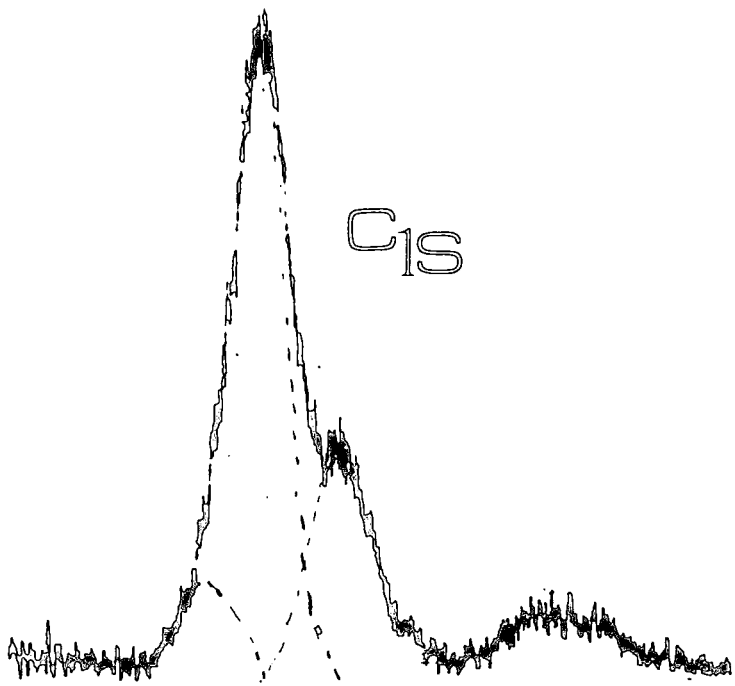

3.7

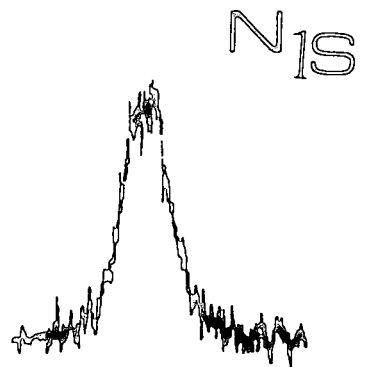
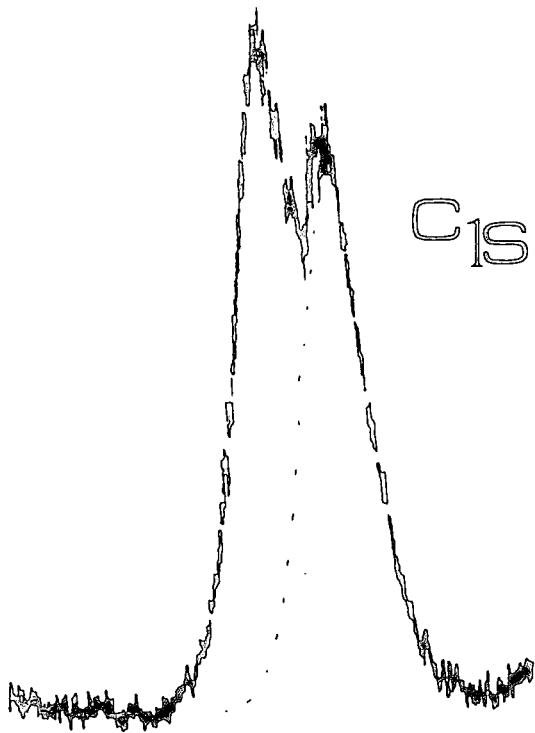

3.8

Figure 3.7 Core level spectra (Ng_{KLL}) of cellulose nitrate prior to acid treatment

Figure 3.8 Core level spectra after 2 minutes treatment with 80% sulphuric acid

occurs in these acids. The glycoside linkage is particularly susceptible to hydrolysis in concentrated acids.³⁴ A degraded cellulose may be regenerated from sulphuric acid solutions by the addition of water.

Earlier in this chapter it has been demonstrated that immersion of cellulose paper into a 98% sulphuric acid-potassium nitrate mix fails to produce a high DOS material despite a high nitronium ion concentration in this mix. The reason for this result is now clear in light of the information presented above. Although the mix is capable of nitration, denitration by the sulphuric acid component will keep the surface DOS very low. Long immersion times result in the destruction of the Whatman paper, this is most likely due to the action of the sulphuric acid on the un-nitrated cellulose.

For academic interest, the stability of a moderately high DOS cellulose nitrate to immersion in a strong sodium hydroxide solution has been investigated. It is reported in the literature that alkali saponification of the cellulose nitrate ester is not possible and treatment of cellulose nitrate with alkali results in solution of the ester.¹⁸ A 2.4 surface DOS cellulose nitrate was immersed in a 20% sodium hydroxide solution at 25°C for 2 minutes. Partial solution of the cellulose nitrate occurred, the material after immersion was very similar in physical appearance to a cellulose nitrate treated with an 80% sulphuric acid-water mix. However, no reduction in the signal from the N_{1s} core

level was observed in the sodium hydroxide solution treated cellulose nitrate.

3.3.2 Nitration in Mixed Acids where the Nitronium ion is not Spectroscopically Detectable

One of Miles's major objections against the nitronium ion's involvement in the nitration of cellulose is centred on the observation that nitration to moderate DOS can be achieved in acid mixes where the nitronium ion cannot be spectroscopically detected. Although the nitronium ion may not be spectroscopically observable, this does not necessarily rule out its presence in the mix. It is clearly important to ascertain if the nitronium ion is still responsible for nitration in such mixed acids. In Table 3.3 surface DOS is presented as a function of nitration time for three mixed acids. The mixes were characterized by Raman spectroscopy. In mix 1 the nitronium ion is spectroscopically observable, in mix 2 it is on the edge of detection and in mix 3 it cannot be detected. As can be seen from Table 3.4 when the nitronium ion is definitely present the nitration reaction at the surface is extremely rapid, complete in 1 second. At the other extreme, when it cannot be detected there is negligible nitration after 1 second, although the final DOS may still be moderately high (1.73).

Table 3.4 Surface DOS monitored with Nitration Time.

Mix Composition	DOS	
	1 second	40 minutes
Mix 1 57% H ₂ SO ₄ , 23% HNO ₃ , 18% H ₂ O	0.1	1.73
Mix 2 60% H ₂ SO ₄ , 23% HNO ₃ , 15% H ₂ O	0.995	1.95
Mix 3 75% H ₂ SO ₄ , 23% HNO ₃ , 2% H ₂ O	2.3	2.3

There is also an appreciable difference in the quality of nitrated materials resulting from preparation in these three mixes. Materials prepared in mixes 1 and 2 were highly degraded. The materials were shredded and brittle, making them difficult to mount on the probe tip prior to analysis by ESCA. In physical appearance they were very similar to the nitrocellulose denitrated in sulphuric acid. The material prepared in mix 3 has retained the fibrous properties of the starting cellulose.

If the water content of mix 1 is raised, even slightly, at the expense of the sulphuric acid component the mix can no longer nitrate cellulose. The product of a short immersion time is exceptionally shredded and impossible to handle. At longer immersion times the cellulose dissolves totally.

An important feature of the above experiment to bear in mind is that the concentration of nitric acid in the three mixes is essentially the same. The extent of ionisation of the nitric acid is observed to decrease with increasing water, or with decreasing sulphuric acid content.

The results in reported Table 3.4 and observations discussed above, can be rationalised in terms of the nitronium ion concentration (and hence rate of nitration) and the sulphuric acid content of the acid mix. Cellulose nitrate is relatively stable to immersion in strong acids, whereas cellulose is not. In mix 3 where the nitronium ion concentration is high, nitration proceeds rapidly and hence degradation of the cellulose is minimized. In mix 2, where the nitronium ion concentration is very low, nitration proceeds much more slowly and the acids (sulphuric mainly) therefore effect severe degradation of the cellulose prior to nitration. When a little water is added to mix 1 the nitronium ion concentration becomes negligible (or perhaps the ion is no longer present) and acid attack of the cellulose chains becomes the predominant reaction. In mix 1 although the nitronium ion cannot be spectroscopically detected it seems reasonable to assume that it is still present in very low concentration and is responsible for nitration. This assumption is supported by spectroscopic studies of nitronium ion solutions. In dilute solutions, <0.2 molar, the nitronium ion cannot be spectroscopically detected, but nitration of cellulose to high DOS takes place in these mixes. In Chapter 6 the presence of the nitronium ion in aqueous acids is considered in much greater detail.

Examination of the three-way nitration diagram, presented Chapter 1, reveals that areas of solution of the cellulose-cellulose nitrate product exist where the water

content of the acid mix is high. The nitronium ion cannot be detected, by Raman spectroscopy, in mixes from these regions. Ionization of nitric acid does occur in mixes of very high sulphuric acid content, no water and low nitric acid content. However, it is anticipated that glycosidic hydrolysis of the cellulose chains is the predominant reaction in such mixes.

From the work presented above it is possible to correlate the behaviour of the surface DOS with changes in the acid mix composition. The results in Table 3.1 will now be considered in terms of a model for the control of DOS at the cellulose surface.

The only species in mixed acids capable of rapidly nitrating cellulose is the nitronium ion, NO_2^+ and its formation is described by equation 1,¹⁴

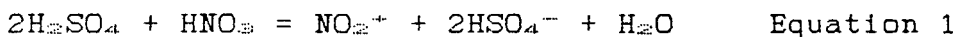

For an acid mix of fixed nitric acid concentration, when the water content is high and the sulphuric acid content low (i.e. mix 1 in Table 3.1), the surface DOS will be kept low by the competing denitration - nitration reactions. The nitrating species, the nitronium ion, is present only in low amount, i.e. the position of equation 1 lies to the left hand side; the denitrating species, presumably the hydrated nitric acid molecule,¹ is present in high concentration, equation 2.

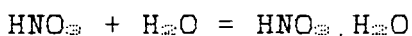

As the water concentration of the acid mix decreases and sulphuric acid concentration increases, the concentration of the nitronium ion and hydrated nitric acid molecule go

up and down respectively: equation 1 moves towards the right hand side and the surface DOS rises. However, as the mix becomes more anhydrous the role of the sulphuric acid, as a denitrating agent, becomes more important. A totally anhydrous mix produces a much lower surface DOS than mixes containing 5-10% water. Hence, it is a fine balance that ultimately controls surface DOS, the maximum DOS is achieved when the effect of the denitrating species are minimized.

The appearance of the nitrite ester has been discussed in Chapter 2. It has been suggested that the appearance of nitrite esters is the result of reactions occurring with stabilization and storage of the cellulose nitrate.¹⁸ This hypothesis is supported by the results obtained from the nitration of cellulose in nitronium ion salt. The N_{1s} core level in Figure 3.6 is symmetric, i.e. the nitrite ester is not detected. These cellulose nitrates are washed well in water and boiled for several minutes. This result implies that the nitrite ester arises during storage or prolonged stabilization. A possible mechanism for nitration in mixed acids is presented in Figure 3.9. The proposed mechanism is supported by the work of Klein and Mentser²⁴ who have shown, by ^{18}O labelling experiments, that esterification is achieved by cleavage of the O-H bond and not the C-O bond.

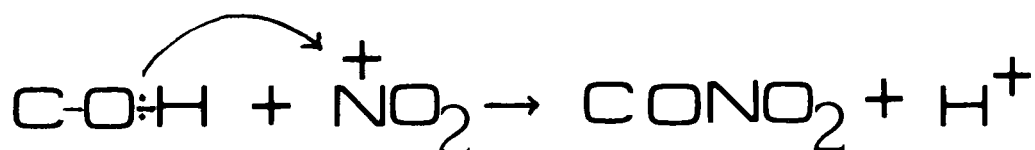

Figure 3.9 Possible mechanism of nitration

3.3.3 The Effect of Fibre Structure on Bulk DOS

To investigate the effect of morphology on the bulk DOS achieved, celluloses from different sources were nitrated in a series of mixed acids. The bulk DOS obtained in the cotton linters, Whatman papers and cellophane film, with the acid mix compositions employed, are displayed in Table 3.5. It is important to note that the three celluloses were nitrated in the same acid mix and therefore no inaccuracy is introduced by repeatedly preparing a particular acid mix. Table 3.5 shows that the DOS achieved, after 3 hours nitration in any of the mixes, is not the same in the three celluloses. Other interesting features were observed that are not displayed in the table. Firstly, the variation in DOS monitored in

the cotton linters was minimal, well within the limits of experimental accuracy, but the variation in DOS monitored for the papers and cellophane, especially, were well outside the limits of experimental error. Secondly, the nitration of cellophane although rapid in mixes 2-5 was very much slower in mix 1 and nitration throughout the entire material was not complete after 3 hours. Finally, the surface DOS monitored for the 3 celluloses nitrated in mix 1 were, within the limits of experimental error the same, as shown in Table 3.6. The surface and bulk DOS were not the same for any of the celluloses nitrated in mixes 1-5, compare the results in Tables 3.1 and 3.5.

Table 3.5 Bulk DOS with Acid Mix Composition*

	Degree of Substitution Cellulose		
	Linters	Papers	Cellophane
1 75% H_2SO_4 , 22.5% HNO_3 , 2.5% H_2O	2.75	2.64	2.11
2 70% H_2SO_4 , 22.5% HNO_3 , 7.5% H_2O	2.82	2.82	2.62
3 65% H_2SO_4 , 22.5% HNO_3 , 12.5% H_2O	2.82	2.77	2.70
4 60% H_2SO_4 , 22.5% HNO_3 , 17.5% H_2O	2.51	2.44	-
5 61% H_2SO_4 , 23.6% HNO_3 , 15.4% H_2O	2.61	2.52	2.37

* Nitrations were carried out at room temperature (22-25°C) for 3 hours. All samples were quenched immediately (no buchnering). Stabilization and drying procedures were as described in section 2.2.1. DOS values presented are the average of, at the least 2 measurements, typically 4 measurements by Elemental analysis.

Table 3.6 Surface DOS of Different Celluloses

Acid Mix Composition	Degree of Substitution		
	Linters	Papers	Cellophane
75% H_2SO_4 , 22.5% HNO_3 , 2.5% H_2O	2.1*	2.29	2.24
75% H_2SO_4 , 22.5% HNO_3 , 2.5% H_2O	2.25	2.30	2.25

* Linters were pressed after nitration to improve S/N (ESCA). The level of extraneous surface contamination was increased by pressing. This might account for the slightly lower surface DOS observed.

It is clear that the equilibrium DOS established at the cellulose surface and the DOS established throughout the cellulose are not the same. Further, the bulk DOS established in different celluloses, in a particular acid mix, are not the same. The immersion times in mix 1 were extended to 10 hours and 1 week. Two important observations were made:-

(i) the bulk DOS in papers and cellophane increased,

(ii) the DOS achieved in the papers was still greater than that achieved in the cellophane.

The studies of Warwicker,²⁷ pertaining to the swelling of cellulose fibres in sulphuric acid and nitric acid, are reviewed in Chapter 1. The conclusions drawn from that work are pertinent when attempting to explain the difference between surface and bulk DOS. The % crystallinity of the starting material is also important in determining the bulk DOS established in the cellulose.

The crystallinity or accessibility of the different cellulose materials, nitrated in Table 3.5, have been

measured by a variety of techniques, see Table 1.3 . It is generally accepted that the % crystallinity of cellulose linters is similar or greater than that of woodfibres (Whatman No.1) and that both are considerably more crystalline than cellophane. This is shown to be the case, below, by sorption measurements¹² and solid state ¹³C nmr¹³⁻²³, for the materials employed in Table 3.5.

The sorption of water, from dry, has been determined separately for the cellulose linters, papers and cellophane sheets. Sorption measurements maybe used to give a rough indication to the proportion of amorphous material in a cellulose.¹²

The celluloses were dried for > 12 hours at 80°C in a vacuum oven, with constant pumping, to ensure that the last traces of water were removed from the celluloses. The dried celluloses were weighed immediately, precautions being taken to ensure that the celluloses did not absorb water prior to weighing included:- letting the vacuum oven up to atmosphere under dry nitrogen and the dessication of the balance chamber with P₂O₅, prior to introduction of the samples. The samples after weighing were exposed to air (relative humidity 80-82%) and reweighed regularly. The results are presented in Table 3.7.

Table 3.7 Increases in %weight of Celluloses with Time

<u>Cellulose</u>	<u>Increase in % weight with time</u>		
	2 hours	4 hours	8 hours
Cellophane	11.5%	11.5%	11.5%
Papers	6.2%	6.2%	6.2%
Linters	6.2%	6.2%	6.2%

From the table it can be seen that the moisture regained in the papers and linters is about the same, 6% by weight, whereas the moisture regained in the cellophane is 11.5%. It is assumed that the amorphous regions in cellulose are mainly responsible for the absorption of water¹² and therefore using the results in Table 3.7, as a rough guide, it is clear that cellophane is considerably more amorphous than either the linters or papers. It was therefore anticipated that a difference in the sorption of linters and papers would be observed; linters are generally considered to be more crystalline than woodfibres. However, without the specially designed apparatus usually employed for this type of experiment¹² it might not be possible to distinguish between materials of very similar crystallinity.

The solid state ¹³C nmr spectra of native celluloses have been reported in several recent publications.¹⁹⁻²³ It has been shown that information on crystal structure¹⁹ and on morphology^{20, 21} can be obtained from the analysis of the solid state spectra, complementing data obtained from other techniques. Earl and VanderHart^{19, 20, 21} have obtained the solid state spectra from a wide range of celluloses. The chemical shifts of all the peaks, C₁-C₆, were observed to be the same in the different celluloses; although differences in the resonances at C₁, C₄ and C₆ were noted. Multiplicities in the C₁ and C₄ resonances in the highly crystalline *Acetobacter* and *Valonia* celluloses were observed with an applied field of B₀=4.7T. Earl and

VanderHart²⁰ have proposed that these multiplicities reflect the fact that there must be more than one type of packing arrangement in cellulose I. At lower applied field the multiplicities were not observed. From the lineshapes of the C₄ and C₆ resonances (B₀=1.4T), Earl and VanderHart^{20,21} have shown information maybe obtained on the sample morphology. In the spectra run of the more amorphous / paracrystalline celluloses, e.g. cotton, the C₄ and C₆ resonances are characterized by a sharp intense peak with a broad shoulder to the high field side. In the more crystalline celluloses examined, Acetobacter and Valonia, the broad component of these resonances had disappeared. Earl and VanderHart have attributed the broader component of these resonances to 'surface' anhydroglucose residues, or residues in disorder regions, and pointed out that in cotton it is estimated that 49% of hydroxyls lie in the elemental fibril surface, whereas for Valonia only 10-14% of hydroxyls lie in surface regions.

Figures 3.8 and 3.9 show the solid state ¹³C nmr spectra of Whatman No.1 papers and cellophane film. The structure of cellophane has received scant attention²⁵ and the solid state ¹³C nmr spectrum displayed in Figure 3.9 is to the author's knowledge the first recorded. In Figure 3.8 multiplicities are evident in the C₆ and C₄ resonances reflecting the crystalline/amorphous nature of cellulose fibres. The cellophane spectrum is similar to those reported for amorphous cellulose.^{21,26} All evidence of the distinct crystalline/amorphous resonances at C₄ and C₆ has been lost. The chemical shift (ppm) of

the 'joint' resonances are closer to those of the amorphous resonance than the crystalline resonance. The structure of cellophane film has recently been investigated by x-ray diffraction, e⁻ beam diffraction and dissolution kinetics.²⁵ Three distinct structure domains were identified: an amorphous region comprising of > 40% of the material; a region with cellulose I type packing (10%) and a region of cellulose type II packing (40-50%). The cellulose I crystallinities were too small to be identified by XRD. The cellulose II crystallinities were destroyed by e⁻ beam diffraction.

The important conclusion to be drawn from comparison of Figures 3.8 and 3.9 is that in terms of % crystallinity cellulose woodfibres are very much more crystalline than cellophane film.

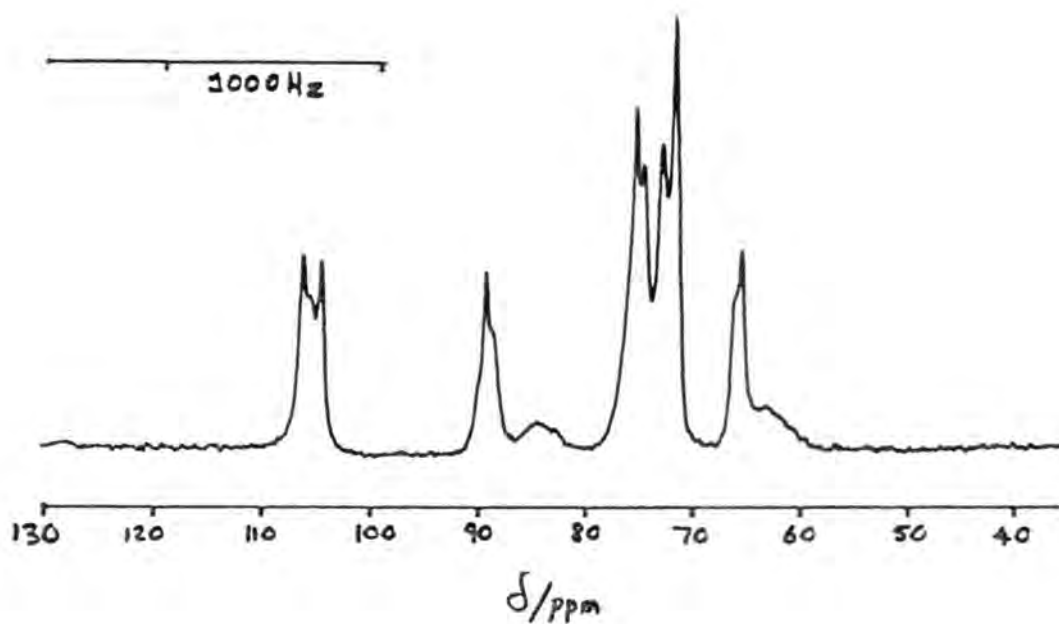

Figure 3.8 The CP/MAS of Cellulose Papers

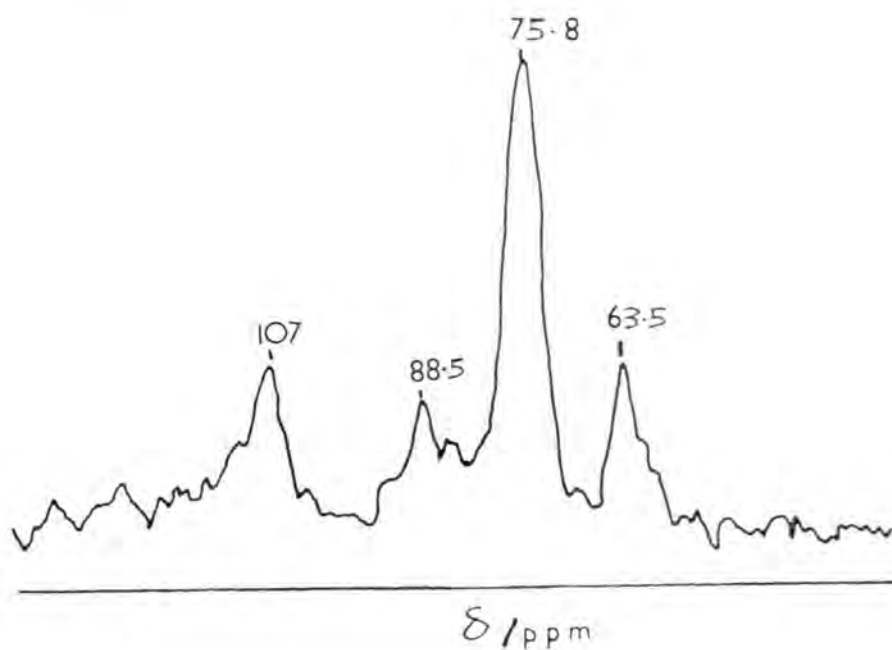

Figure 3.9 The CP/MAS of Cellophane

The bulk DOS obtained for cellophane and the bulk DOS obtained for linters or woodfibre after 3 hours nitration in the same acid mix are very different. It is clear that the morphology of cellophane is also very different to that of the cellulose fibres. In view of the data presented in this section, it does not seem unreasonable to suggest that the most important factor controlling the bulk DOS, obtained in a mixed acid, is the morphology of the cellulose.

Warwicker²⁷ has shown that sulphuric acid can not penetrate into the crystalline regions (i.e. intrafibrillar regions) of cellulose fibres. It has been proposed that this is a consequence of the size and shape of the sulphuric acid molecule.²⁸ The sulphuric acid molecule is non planar. The hydrogen bonding in crystalline cellulose gives it a sheet like structure.²⁹ Planar molecules may 'slip' between these sheets but non-planar molecules cannot. The nitric acid molecule and more importantly the nitronium ion are both planar. Hence, nitric acid can penetrate both interfibrillarly and intrafibrillarly in cellulose.

As a consequence of the above discussions it follows that the hydroxyls in a crystalline material are, therefore, 'inaccessible' to the denitrating species, but accessible to the nitrating species. Consequently nitration in the crystalline regions proceeds to high DOS, whilst, nitration in the disordered regions is limited by the concomitant denitration reactions. Destruction of the crystal structure, i.e. reduction in the % crystallinity,

of a material increases the accessibility of the bulk cellulose to the denitrating species and hence the DOS that can be achieved decreases. The results in Table 3.5 support this hypothesis. However, with nitration, large changes occur in the unit cell of cellulose and the overall crystallinity of the cellulose fibre is thought to decrease. Hence, it is probably more appropriate to consider the crystalline regions as being less accessible (cf. amorphous regions), rather than inaccessible, to sulphuric acid.

Several other observations, outlined below, support the general conclusions, drawn above.

(1) The results presented in this chapter show that the surface DOS is lower than the corresponding bulk DOS in cellulose nitrates prepared from mixed acids. At the cellulose fibre surface the accessibility of the hydroxyl groups to the various components of the acid mix will be equal and therefore at the surface it is expected that the 'true equilibrium' DOS of the nitrating mix will be established. As argued above, inside the fibre the accessibility of the hydroxyls to the various components of the acid mix is not equal. Hence, at the surface of the fibre the action of sulphuric acid limits the DOS achieved; however, in the bulk, particularly in the crystalline regions, the sulphuric acid content of the nitrating mix is lower, than at the surface, and therefore the DOS achieved is greater since it is not limited by the denitrating action of sulphuric acid.

(ii) From a solution state ^{13}C nmr study of nitration, Fowler et al²⁹ have observed that the bulk DOS achieved by nitration in a 60% H_2SO_4 , 22.5% HNO_3 , 17.5% H_2O acid mix does not remain constant with exposure time. The DOS in a nitrated material initially increases with exposure time, but the DOS reaches a plateau after 2-4 days immersion after which there was a steady decrease in the DOS and concomitant loss of fibrous structure in the cellulose nitrate. The cellulose nitrates retrieved from this nitrating mix after 1 weeks immersion were extensively degraded and were powdery in form.

This result indicates that as the fibre structure in a cellulose is destroyed, the bulk DOS that can be achieved by nitration, in a mixed acid, decreases.

(iii) Berl and Klave³¹ and Bonnet and Demougin³⁶ have demonstrated that nitration and denitration in mixed acids do not proceed at the same rate, but with sample disintegration at long immersion times nitrated and denitrated materials reach the same DOS. It is not surprising that the rates of nitration and denitration in fibrous materials are not the same since the accessibility of the fibre to the nitrating and denitrating species is not the same. At long exposure times, with destruction of the fibre structure it is, in view of the arguments presented above, to be expected that the nitrated and denitrated materials will reach the same DOS since the accessibility of the cellulose hydroxyls to the nitrating species and denitrating species will become equal.

(iv) There is variation in the reproducibility in the bulk DOS measured for cotton linters, Whatman papers and cellophane. The bulk DOS monitored, by elemental analysis, in linters is very reproducible, whilst the DOS measured in Whatman papers and cellophane film is not. The variation in bulk DOS in Whatman papers is about 0.1, the variation in the bulk DOS in cellophane is of the order 0.2-0.3. Further, the maximum DOS observed in the papers is equal to the average DOS of the linters. It is thought that the measured variation in bulk DOS reflects the variation in the crystallinity of the cellulose. The more regular the crystal structure throughout the cellulose the more reproducible the DOS achieved.

(v) As is shown later, in phosphoric-nitric acid mixes the surface and bulk DOS achieved are the same. Concentrated phosphoric acid can swell cellulose both inter and intrafibrillarly.²⁷

Different reactivities of the crystalline and amorphous regions in cellulose fibres have been observed by solid state ^{13}C nmr studies in other derivatizations³¹ and reactions of cellulose.²⁴ For example, solid state ^{13}C nmr has shown that acid hydrolysis, of cellulose chains, in cotton linters occurs predominately in the three dimensional regions of disorder.²⁴

The data in Table 3.5 has been used to argue that the crystal structure of cellulose facilitates the production of a higher DOS cellulose nitrate than could be achieved by nitrating amorphous cellulose. It is paradoxical to consider that if this hypothesis is correct

the role played by the crystalline regions is the opposite to that originally envisaged.' Rather than being inaccessible to the nitrating species, the crystalline regions are inaccessible to the denitrating species.

3.3.3 Nitration outside the Technical Zone

The data displayed in Table 3.8 refers to the nitration of Whatman Papers in a mixed acid of a composition from well outside the technical zone. The nitronium ion band, 1400 cm^{-1} , is prominent in the Raman spectra of this mix. Nitration at the fibre surface is observed by ESCA to be complete < 5 seconds. From Table 3.8 it is evident that surface and bulk DOS are different. Acid mixes of this composition are rarely employed because nitric acid is more expensive than sulphuric acid.

Table 3.8 Nitration with a 57.6% H_2SO_4 , 40.1% HNO_3 mix

	Degree of Substitution	
	Surface	Bulk
Papers	2.35	2.89

Clearly there are important similarities between nitration in mixes inside and outside the technical zone. Firstly, the nitronium ion is probably responsible for nitration in mixes from outside the technical zone, where nitration is observed to be extremely rapid at the fibre surface. Secondly, the surface and bulk DOS, as observed in technical mixes, are not the same.

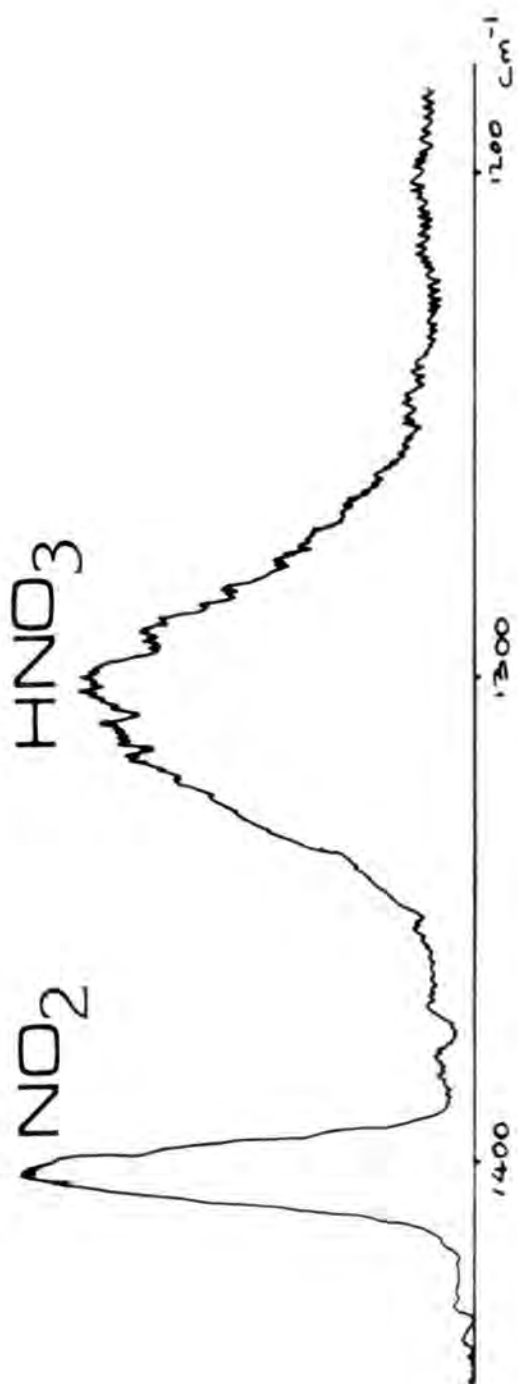

Figure 3.10 Raman Spectra of a Phosphoric-Nitric Acid Mix. prepared as described by Mitchell^{3e}

3.3.4 Nitration with Phosphoric-Nitric Acid Mixes

The typical Raman spectrum of a Phosphoric-Nitric acid mix is presented in Figure 3.10. This figure shows that the nitronium ion band at 1400cm^{-1} is prominent. Stephenson¹⁹ has reported that the surface and bulk DOS obtained in these mixes are in close agreement. In Table 3.8 the surface and bulk DOS for the nitration of Whatman papers in a phosphoric-nitric acid mix are presented.

Table 3.8 Nitration in a Phosphoric-Nitric Acid Mix²⁸

Mix	Degree of Substitution	
	Surface	Bulk
67cm ³ HNO ₃ , 142g P ₂ O ₅ ,	1.9	2.01
64cm ³ H ₂ O	1.95	2.12

The agreement in surface and bulk DOS is much closer than that observed for celluloses nitrated in sulphuric/nitric acid mixes. This result indicates that nitration is more homogeneous throughout the cellulose. Warwicker²⁷ has shown that concentrated phosphoric acid can cause both intra and interfibrillar swelling in cellulose and hence it seems reasonable to assume that the composition of the nitrating mix at the fibre surface in the crystalline bulk are very similar and this is why nitration is homogeneous throughout the fibre. This result adds further supporting evidence to the argument presented in section 2.3.3 where it is proposed that the different surface and bulk DOS achieved, by nitration in

technical mixed acids, are a consequence of sulphuric acids inability to penetrate the cellulose crystallinities.

3.3.5 Summary

In the first part of this chapter the nitronium ion has been shown to be the important nitrating agent of cellulose. In nearly all other organic nitrations it has been well established that the nitronium ion is responsible for nitration¹³ and it is suprising that 35 years after the work of Ingold et al¹³ that many authors still consider nitric acid as the important nitrating agent of cellulose.²

The mechanisms controlling the surface DOS achieved, by nitration in a technical acid mix, are explained in terms of the acid mix composition. Nitration proceeds via the nitronium ion and concentrated sulphuric acid is shown to be capable of denitrating cellulose nitrate. Hence, it is established that at the cellulose fibre surface DOS is equilibrium controlled.

In the second part of this chapter it is shown that fibre structure plays an important role in controlling the DOS achieved in cellulose by nitration with technical acid mixes. Cellulose crystallinities are considered to be more inaccessible to sulphuric acid than the amorphous and surface regions, hence the composition of the acid mix at the surface and in the bulk maybe different. From this it follows that the DOS established at surface and in the bulk will be different, and that the DOS established in celluloses of different crystallinities will not necessarily be the same.

The results presented in this chapter show that the accessibility and equilibrium arguments for the control of DOS are compatible once the actions of the various components in the mix are known.

REFERENCES

- 1 F.D. Miles 'Cellulose Nitrate', Interscience, London 1953.
- 2 A.H.K. Fowler, Ph.D. Thesis, 1984, University of Durham.
- 3 J. Barsha in 'Cell. and Cell. Derivs.', 2nd. edition, part II, Ed. H.M. Spurlin and M.W. Grafflin, Interscience, N.Y., 1954.
- 4 Chedin in ref. 1.
- 5 E.D. Hughes, C.K. Ingold and R.I. Reed, J Chem. Soc. 1950, 2400.
- 6 E.S. Halberstadt, E.D. Hughes and C.K. Ingold J. Chem. Soc. 1950, 2441.
- 7 C.K. Ingold 'Structure and Mechanism in Organic Chemistry', Bell, London, 1953.
- 8 C.A. Burton with (a) E.A. Halevi and D.R. Llewellyn, J. Chem. Soc., 1952, 4913; (b) E.A. Halevi, J. Chem. Soc., 1952, 4917; (c) G. Stedman, J. Chem. Soc., 1958, 2420.
- 9 T. Urbanski, 'Chemistry and Technology of Explosives', Vol II, Pergamon Press, London, 1984.
- 10 J. Trommel, J. Commun. N.V. Koninklijke Nederlandsche Springstoffenfabrieken, Amsterdam, No. 13.
- 11 J. Trommel, Comm. No. 15.
- 12 R. Jeffries in 'Methods in Carbohydrate Chemistry', vol III, Ed. R. Whistler, Academic Press, London, 1963.
- 13 J.G. Hogget, R.B. Moodie, J.R. Penton and K. Schofield 'Nitration and Aromatic Reactivity', Cambridge Univ. Press, 1971.
- 14 C.K. Ingold, D.J. Millen and H.G. Poole, J. Chem. Soc., 1950, 2577.
- 15 C.K. Ingold, D.J. Millen, J. Chem. Soc. 1950, 2612.
- 16 D.T. Clark, P.J. Stephenson, Polymer, 1982, 23, 1034.

CHAPTER FOUR - A RE-INVESTIGATION OF THE LOW
TEMPERATURE NITRATION OF CELLULOSE

4.1 INTRODUCTION

At room temperature nitration with technical acid mixes in the surface region is extremely rapid, the equilibrium DOS being established to a depth of $> 100 \text{ \AA}$ in about one second.¹ In practice it has proved impossible to study the approach to equilibrium DOS as a function of time, at room temperature, as the nitration and quenching procedures can not be carried out in much less than a second.¹

In an attempt to slow down the initial stages of reaction, at the cellulose surface of Whatman No. 1 papers, Clark et al^{2,3} have carried out nitrations in three technical acid mixes at reduced temperatures for 30 seconds. The nitrated samples were analyzed by ESCA (Mg_{K α} x-rays). For mixes of the composition:-

(1) 75% H₂SO₄, 22.5% HNO₃, 2.5% H₂O

(2) 70% H₂SO₄, 22.5% HNO₃, 7.5% H₂O

(3) 60% H₂SO₄, 22.5% HNO₃, 17.5% H₂O

3 temperature versus DOS curves were produced and these are displayed in Figure 4.1. From this figure it can be seen that reduction of the nitrating temperature, below 5°C, results in a depression in the DOS achieved in all 3 acid mixes investigated. It is interesting to note that the 3 curves in Figure 4.1 are parallel. Fowler⁴ put forward various explanations to describe the shape of these curves:-

(i) the rate of nitration decreases with the temperature of the acid mix; i.e. the curves are a reflection of the time dependence of nitration,

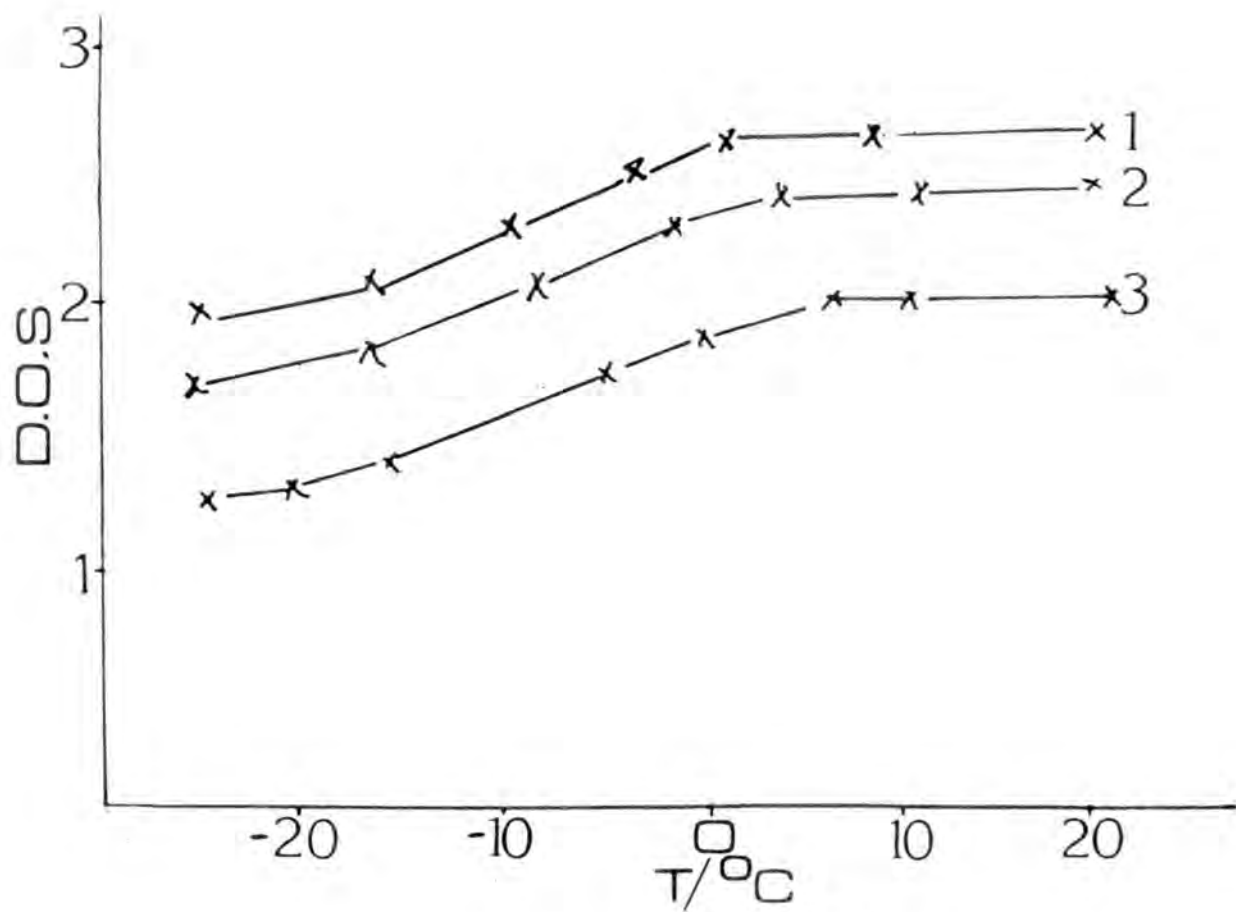

Figure 4.1 Graphs of DOS versus temperature.

(ii) the diffusion rate of the acid mix into the cellulose fibril decreases with temperature; i.e. the viscosity of the acids increase with a depression of the mixes' temperature,

(iii) the equilibrium constant for the formation of the nitrating agent is temperature dependent; or the equilibrium constant for the reaction of the nitrating agent with the hydroxyl groups is temperature dependent.

To ascertain in (i) the possible role of the kinetics in the nitration reaction, the experiments were repeated at -25°C extending the immersion times from 30 seconds to 1 hour. It was argued that if the curves in Figure 4.1 resulted from slowing down of the nitration reaction, then on extending the nitration time to 1 hour the surface DOS observed would rise to some greater value, approaching the value obtained at room temperature. However, it was observed that the surface DOS of the Whatman papers after 1 hours immersion were unchanged in the 3 mixes investigated; further it was noted that no bulk nitration could be detected by Kjeldahl analysis and that the d_{100} spacing of the celluloses were still representative of cellulose I.

With respect to (ii) above, Fowler argued that there was no reason to suspect that at the cellulose surface the nitration reaction would be influenced by diffusion or viscosity. To check this, TiK_{α} x-rays were employed to monitor the DOS in the top 150 Å of the celluloses after 30 seconds nitration. Since the extent of nitration observed was essentially the same as in

Figure 4.1, it was concluded that diffusion does not play an important role in the surface over the top 150 Å.

From the elimination of (i) and (ii) above, Fowler considered that the effect of lowering the temperature of a technical acid mix must be to perturb the thermodynamics, rather than the kinetics, of nitration. The DOS values in Figure 4.1 were taken to be representative of 'final equilibrium' DOS and the linear portions of the three curves were treated employing the Van't Hoff Isochore (equation 1) to determine the heat of formation of cellulose nitrate in each of the 3 mixes. It was assumed that the activities of the acids and water were unity, and temperature independent, and that the DOS could be treated as the activity or concentration of the product at the various temperatures. The heat of formation of cellulose nitrate was calculated to be endothermic in the 3 acid mixes investigated. In contrast, by microcalorimetry Calvets⁶ has determined the heat of formation to be - 20 kcal/mole, i.e. exothermic, for cellulose nitrates of 11.7-13.0 % N. Employing the Van't Hoff Isochore,

$$\frac{d \log_e K}{dt} = \frac{dH}{RT^2} \quad \text{Equation 1 .}$$

it can be seen that on reducing the temperature of a technical mix there will be an increase in $d \log_e K$ and hence an increase in the extent of nitration. K was described by

$$K = \frac{[\text{Cell-ONO}_2][\text{H}_2\text{O}]}{[\text{HNO}_3][\text{Cell-OH}]}$$

It was demonstrated in chapter 3 that the DOS achieved in a cellulose, by nitration with a technical

mixed acid, is controlled by the competing nitration-denitration equilibria. At room temperature an acid mix capable of supporting a 2.0 DOS cellulose nitrate will denitrate a higher DOS material.⁶ In the bulk of the cellulose denitration is slow, since the diffusion of the acid mix into the fibres is slow, but at the fibre surface ESCA has shown denitration to be extremely rapid.¹ From Figure 4.1 it is evident that below 5°C the DOS monitored in the surface region of a cellulose is considerably reduced from that at +25°C. If the lowering in DOS is a consequence of a perturbation of the nitration-denitration equilibria, then it would be expected that at < 5°C a technical acid mix will not support the cellulose nitrate manufactured in the that mix at > 5°C. Employing ESCA it is possible to monitor any denitration at the fibril surface resulting from a re-immersion of a cellulose nitrate in its own acid mix at low temperature. This possibility is investigated.

The existence of the equilibria,



is well established in technical mixed acids.⁷ The utilization of Raman Spectroscopy to monitor the various concentrations of the species in technical mixed acids has been described in Chapter 3. In the last chapter it was shown that the nitronium ion, NO_2^+ , is the important nitrating agent of cellulose in technical mixed acids. Hydrated nitric acid, $\text{HNO}_3 \cdot \text{H}_2\text{O}$ is thought to be the denitrating agent in mixed acids of low % sulphuric acid, high % water content.¹⁶ At higher % sulphuric acid content it has been proposed that this acid also

denitrates the cellulose (Chapter 3). Any perturbation in the nitration-denitration equilibria ought to be manifest as a change in the concentration of these species.

In the course of this chapter ESCA is used to investigate the action of technical mixed acids over the temperature range -25°C to $+22^{\circ}\text{C}$ on cellulose and cellulose nitrates; Raman Spectroscopy is utilized to examine the effect of temperature on the concentration of the various species in technical acid mixes.

4.2 EXPERIMENTAL.

The starting cellulose used in this study was Whatman No.1 paper as described previously.

Experimental procedures are outlined in Section 2.2.

Nitrations at low temperature were accomplished by either cooling the acid mix in a freezer or by means of a acetone/dry ice slush bath.

The use of ^{13}C nmr and X-ray diffraction is described in Section 2.2. The analysis of the ^{13}C nmr spectra is discussed in Section 4.3.5.

ESCA spectra were run on a Kratos ES300 electron spectrometer.

All Raman spectra were run on a Varian Cary 82 Raman spectrophotometer using an Argon gas laser (514.5nm, 200mW). The temperature of the acid mix monitored was regulated by means of a liquid nitrogen cooled cryostat.

RESULTS AND DISCUSSION.

4.3.1 A Preliminary Investigation of Quenching Procedure.

Before investigating the feasibility of denitrating cellulose nitrates with technical mixed acids maintained at low temperature, it was first considered necessary to establish the most effective method for removal of the acids from the cellulose at low temperature; i.e. the best method of quenching. In Chapter 2 it has already been shown that at room temperature the chosen method of quenching, (i) or (ii) below, does not seriously effect the surface DOS as monitored by ESCA.

(i) In 5 litres of water immediately following removal of the ' green ' cellulose nitrate from the acid mix;

(ii) in 5 litres of water after first sucking off any adhering acid on a buchner funnel.

The effect of the two quenching procedures, at lower temperatures, on the surface DOS have been investigated. Cellulose papers were nitrated in a technical mixed acid for 2 minutes at -20°C ; after quenching, by methods (i) or (ii), the surface DOS were monitored by ESCA, the results are presented in Table 4.1. The sample in (ii) was buchnered for 40 seconds approximately: the buchner funnel had previously been 'cooled' in a freezer maintained at approximately -20°C .

Table 4.1 The Effect of Quenching Procedure on Surface DOS.

Acid Mix	Degree of Substitution	
	<u>Quenching Procedure</u> (i)	(ii)
75% H ₂ SO ₄ 22.5% HNO ₃ 2.5%H ₂ O	1.4	2.35

It can be seen from Table 4.1 that the two methods of quenching produce a very different DOS in the surface region. Method (i) was chosen, as the best method of quenching, on the grounds that:-

(i) at room temperature, immediate quenching gives a reasonable DOS value in the surface region, see Chapter 2;

(ii) the increase in the surface DOS observed when the cellulose nitrate is buchnered can, perhaps, be attributed to an increase in the temperature of the adhering acids not immediately removed from the cellulose.

The latter justification has subsequently shown to be only partially correct and there is a much better justification for choosing (i), to quench immediately, that only came to light during the course of this work.

4.3.2 A Study of ' Low Temperature Denitration'

A cellulose nitrate of surface DOS 2.3 was prepared in a 75%H₂SO₄, 22.5%HNO₃, 2.5%H₂O technical acid mix at room temperature. Pieces of this cellulose nitrate were immersed in fresh acid mixes of the same composition for > 2 minutes at various temperatures in the range +20°C to

-20°C. The final surface DOS were monitored by ESCA and the results are displayed in Table 4.2.

Table 4.2 Surface DOS with Acid Mix Temperature.

Temperature of Acid Mix	Degree of Substitution
20°C	2.3
- 7°C	2.4
-15°C	2.3
-20°C	2.3

From the table it can be seen that the original surface DOS of the starting material (2.3) has remained unaffected by the immersions. Infact, the DOS after the low temperature immersions appears to have risen slightly, but the increase in DOS observed is not outside the realm of experimental error. The experiment was repeated several times employing similar composition acid mixes; no denitration was detected. Further, on extending the immersion times at low temperature no denitration was observed.

However, cellulose papers (Whatman Number 1) immersed in a 75% H₂SO₄, 22.5% HNO₃, 2.5% H₂O acid mix for 2 minutes at -15°C only nitrated to a surface DOS of about 1.4. Further, there is considerable variation in the level of nitration monitored (well outside the normal limits of experimental error, see Chapter 2).

The entire experiment was repeated using an acid mix of composition 65%H₂SO₄, 22.5%HNO₃, 12.5%H₂O over a similar temperature range. Again, the DOS of the

starting cellulose nitrate (2.3) remained unaffected by immersion in the fresh acid mixes at any temperature in the range -30°C to $+20^{\circ}\text{C}$. Two minutes nitration in this mix at -15°C failed to produce a surface DOS anywhere near that approaching the room temperature equilibrium value of 2.3.

In Section 4.1 it was suggested that denitration would be expected in the type of experiments described above. This expectation was based on the premise that the nitration-denitration equilibria are perturbed in favour of denitration at low temperature. However, the results presented show that this is evidently not the case.

It is important to note that the denitration reaction can still be observed in technical acid mixes maintained at low temperature. Pieces of a cellulose nitrate, surface DOS 2.6, were immersed in an acid mix that only supports a surface DOS of 2.2 at room temperature, for 30 seconds at various temperatures in the range -30°C to $+20^{\circ}\text{C}$, the results are displayed in Figure 4.2. From this figure it can be seen that denitration has occurred in the surface and it has been extremely rapid at all temperatures in this range. It is also apparent that at all temperatures, denitration occurs down to about the same DOS (2.2-2.3). The DOS being only slightly greater at the lower temperatures. The results of this experiment suggest that the final equilibrium DOS for this mix, over the entire temperature range investigated, is about 2.2; i.e. over this

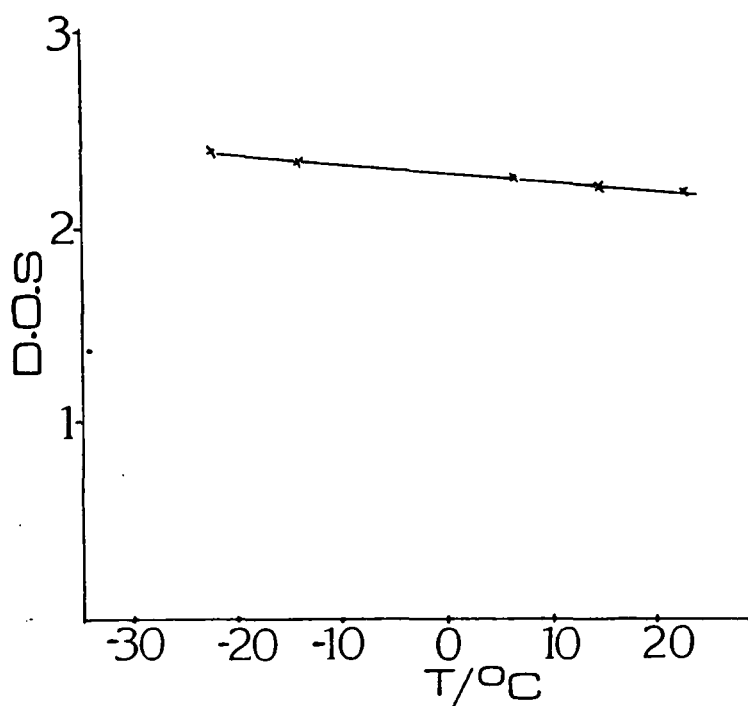

Figure 4.2 'Attempted' Denitration at Low Temperature.

temperature range, the balance position of the nitration - denitration equilibria are not influenced by temperature. This conclusion is in direct contrast to the conclusion drawn from the work of Fowler.⁴

4.3.3 A Raman Temperature Study of Mixed Acids.

The importance of the balance position of the equilibrium,



in determining the final surface DOS has been discussed in Chapter 3. By monitoring the relative concentration of the above species in technical mixed acids, changes in the surface DOS can be rationalized. By employing Raman Spectroscopy the relative concentrations of the above species maybe monitored in technical acid mixes from

-30°C to +20°C. Information from this type of experiment will enable a better understanding of the complex relationship exists between the temperature of the nitrating acid mix and the surface DOS to be developed.

To this purpose, 3 technical acid mixes were characterized over the temperature range -25°C to +20°C. 250 - 1500 cm^{-1} Raman scans were taken of the technical acid mixes:-

(i) 75% H_2SO_4 , 22.5% HNO_3 , 2.5% H_2O

(ii) 67% H_2SO_4 , 25 % HNO_3 , 8 % H_2O ,

(iii) 59% H_2SO_4 , 26.0% HNO_3 , 14.0% H_2O ,

The Raman scans of mix 1 ran at +20°C, +3°C and -19°C are displayed in Figures 4.3-4.5 respectively. From comparison of the peak heights at 1400 cm^{-1} and 1300 cm^{-1} it can be seen that the concentration of the nitronium ion relative to that of molecular nitric acid remains essentially unaffected by the temperature perturbation. The change in peak intensities at 1050 cm^{-1} and 925 cm^{-1} are not thought to significantly effect DOS in a 65% sulphuric acid mix.

The Raman Scans of mix 2 ran at -20°C and +20°C and the Raman Scans of mix 3 ran at +20°C and -12°C are displayed in Figures 4.6, 4.7, 4.8 and 4.9 respectively. Again, from visual examination of these figures it can be seen that temperature does not seriously influence the concentrations of the nitronium ion and molecular nitric acid in these 2 mixes.

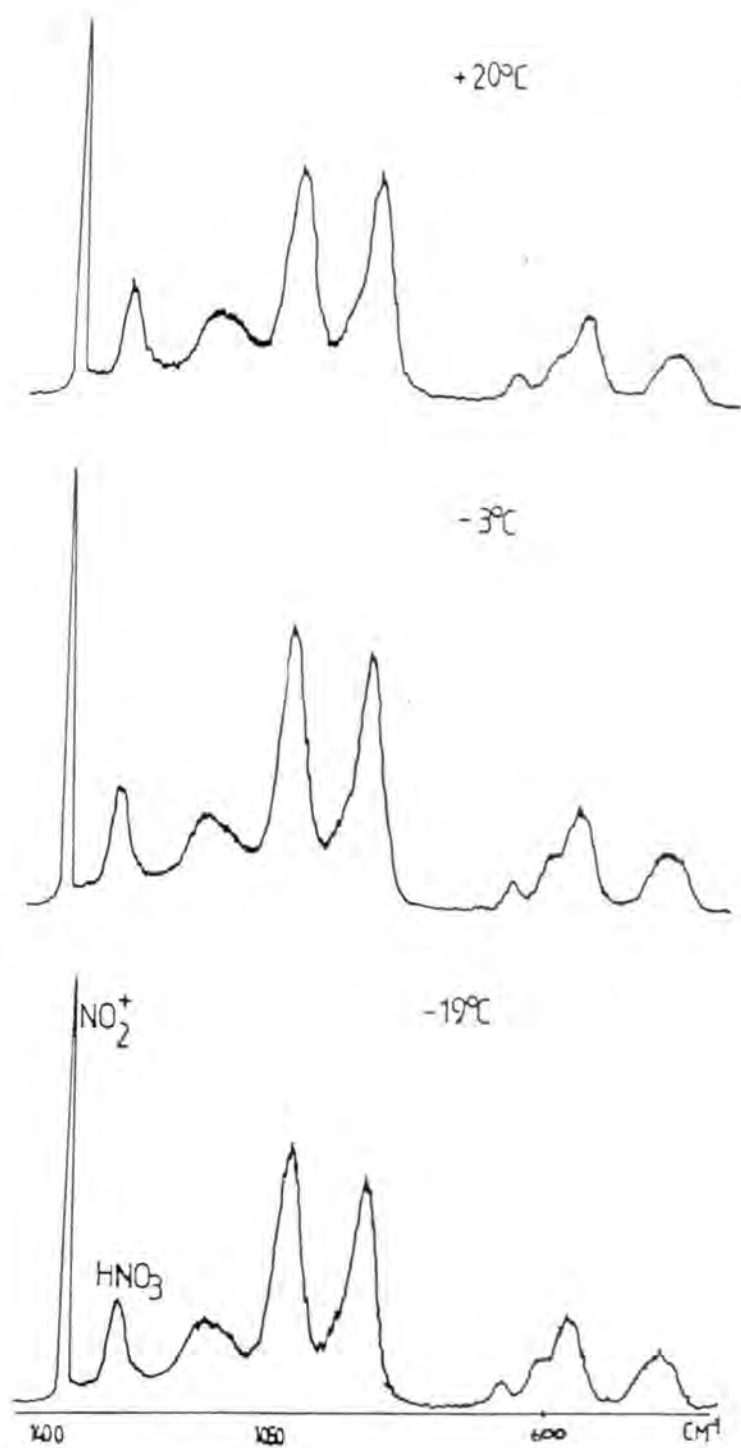

Figures 4.3-4.5 Raman Spectra with Temperature of a
75%H₂SO₄, 22.5%HNO₃, 2.5%H₂O Mixed Acid

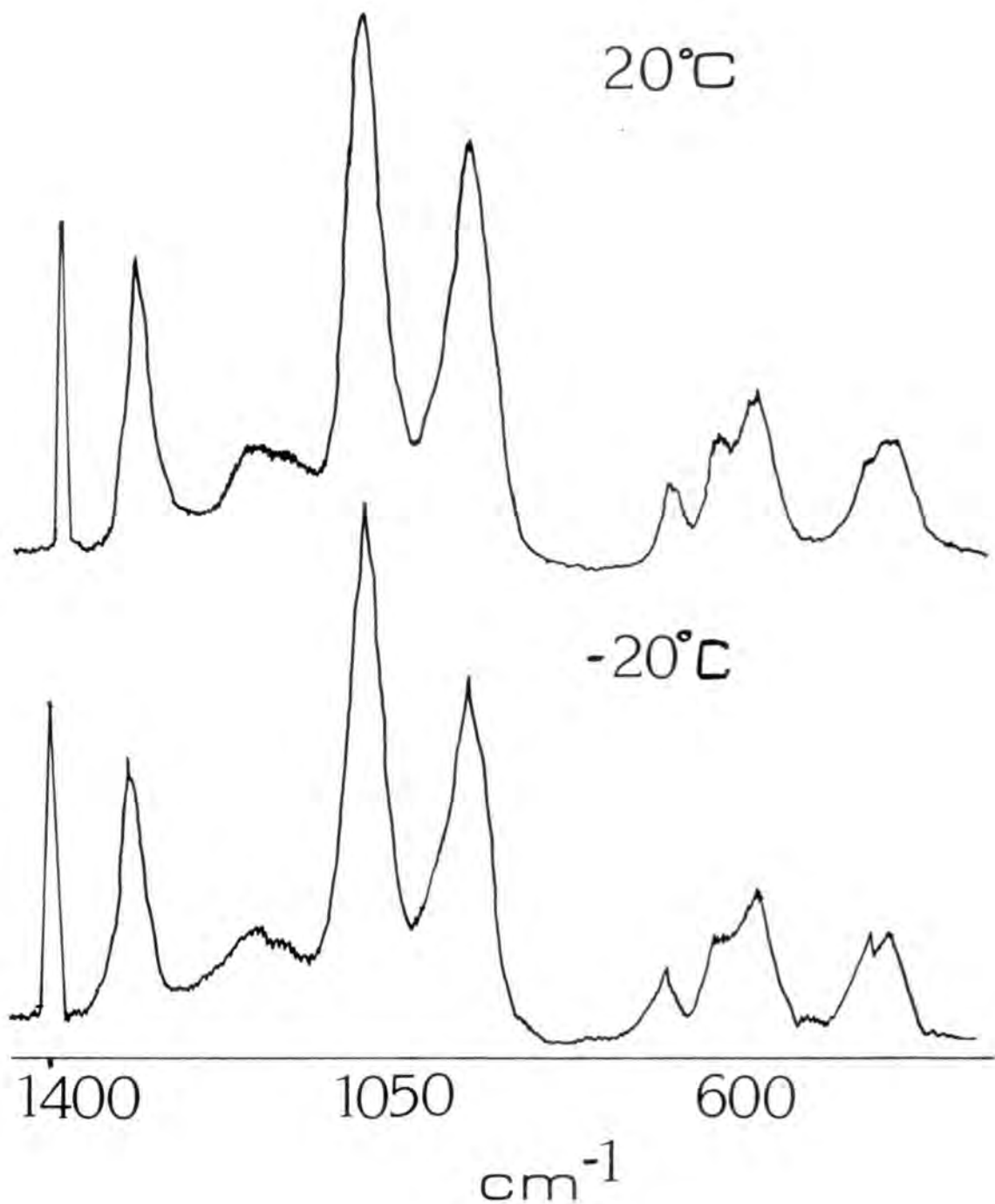

Figures 4.6 and 4.7 Raman Spectra with Temperature of a 67% H_2SO_4 , 25 % HNO_3 , 8 % H_2O Mixed Acid.

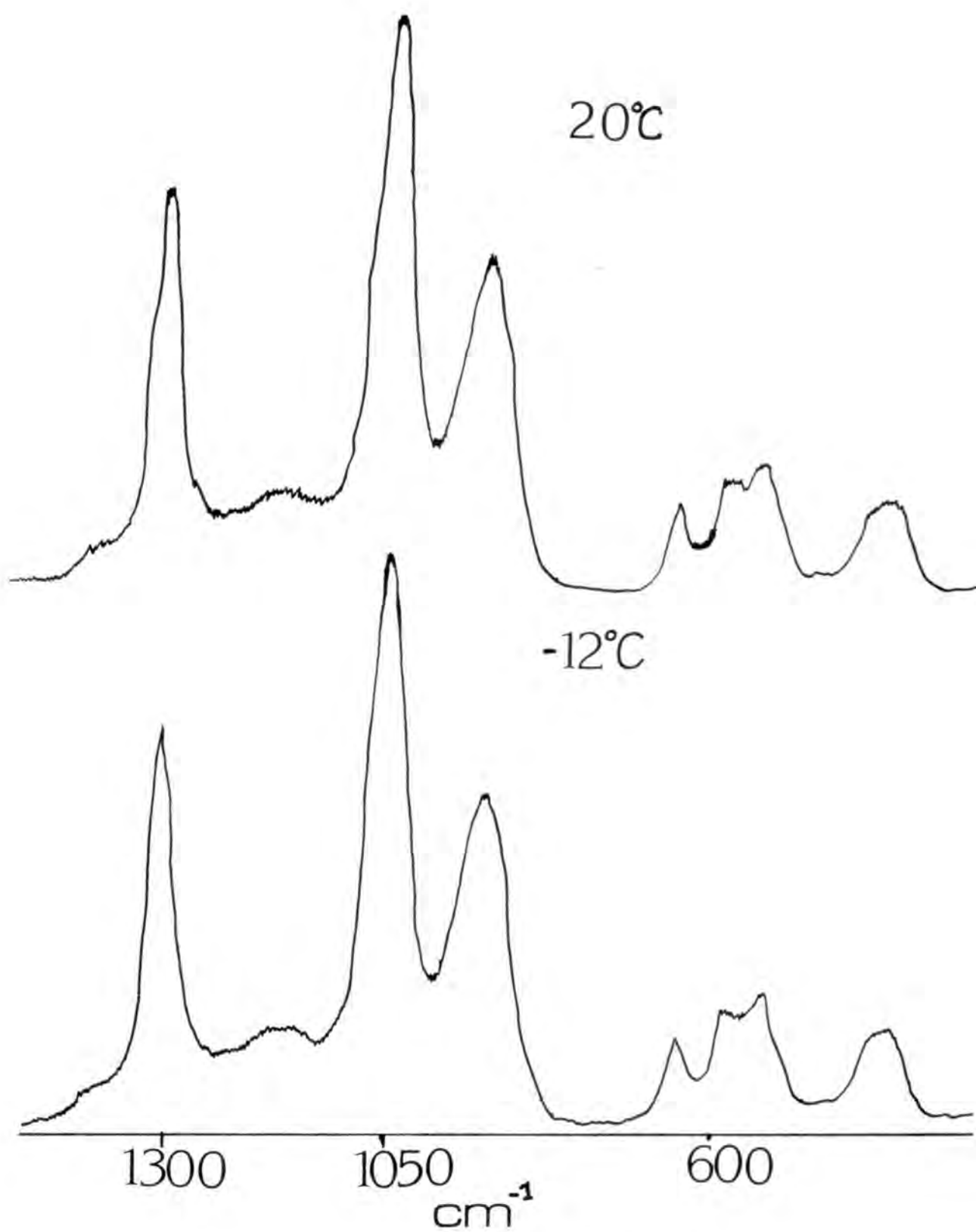

Figure 4.8 and 4.9 Raman Spectra of a 59% H_2SO_4 ,
26.0% HNO_3 , 14.0% H_2O Mixed Acid with Temperature.

In Table 4.3 the heights of the nitronium ion and molecular nitric acid peaks are ratioed from the Raman scans of mixes 1, 2 and 3, to facilitate comparison of the relative concentrations of these two species at the various temperatures investigated.

Table 4.3 Ratioed Intensities of the Nitronium Ion and Nitric Acid Peaks.

Acid Mix	NO ₂ ⁺ /HNO ₃	
	R.T	L.T.
1	4	5
2	1.2	1.4
3	-	-

RT = Room Temperature 20°C,
 LT = Low Temperature, see spectra.

At the lower temperature, for each of the 3 mixes, the concentration of the nitronium ion can be seen to have slightly increased, relative to that of the molecular nitric acid.

Fowler⁴ has proposed that the curves in Figure 4.1 represent 'final equilibrium' surface DOS, concluding that " the equilibrium constant for the formation of the nitrating species [now established as the nitronium ion] is temperature dependent; or that the equilibrium constant for the reaction of the nitrating agent with hydroxyl groups is temperature dependent." From the above Raman study it is evident that the equilibrium describing the formation of the nitrating agent, the nitronium ion, is not particularly temperature sensitive. If the formation of the nitrating species is the predominant factor controlling the DOS obtained in mixed acids, then from the data in Table 4.3 it can be seen

that an increase in DOS would be anticipated as the temperature of the nitrating acid mix is reduced.

It is still possible that the equilibrium constant for the reaction of the nitronium ion with the cellulose hydroxyls is temperature dependent; i.e the reaction is endothermic and therefore not favoured at low temperature. This explanation seems unlikely since calorimetric studies of nitration (in mixed acids, liquid nitric acid) have shown nitration to be exothermic⁵. However, although the reaction maybe exothermic, there may well exist an insurmountable potential energy barrier preventing reaction at low temperature.

It is known that the rate constants for nitration at the C₂, C₃ and C₆ hydroxyl sites differ.⁶ The rate of substitution being much faster at the C₆ site than at C₂ or the C₃. This has been discussed more fully in Chapter 2. It has been argued that the energy barrier to nitration differs at these 3 sites and that this difference is more attenuated at low temperature: i.e. at low temperature many more C₂ and C₃ hydroxyls in the cellulose becoming 'thermodynamically inaccessible' to nitration.² However, this hypothesis does not explain why a technical acid mix, maintained at low temperature, although capable of denitration continues to support a cellulose nitrate of a high DOS.

In view of the conflict between the presented data above and the data presented by Clark and Fowler,² it was decided to experimentally re-investigate low temperature nitration.

4.3.4 Low temperature nitration.

The curves in Figure 4.1 were considered by Clark and Fowler to be representative of 'final equilibrium' DOS on the grounds that extension of the nitration time to 1 hour, at -25°C , produced no change in the surface DOS. However, during the course of this work it was found that at very low temperatures technical acid mixes become extremely viscous and that on scratching with a glass rod develop crystals. To avoid these problems, of viscosity and freezing, it would perhaps have been wiser to have extended the immersion period at some higher temperature (e.g. -15°C).

To this effect cellulose papers were immersed in a $60\% \text{H}_2\text{SO}_4$, $25\% \text{HNO}_3$, $15\% \text{H}_2\text{O}$ technical mixed acid maintained at about -15°C for 3 hours. The papers were then analysed by ESCA and by micro-Kjeldahl analysis. Two important discoveries were made:-

- (i) the 'final' surface DOS was found to be 2.4,
- (ii) the bulk nitrogen content of the cellulose nitrate was $> 12\%$ by weight, after washing and appropriate stabilization.

A surface DOS of 2.4 would not have been expected, if the curves in Figure 4.1 represent final DOS; at room temperature the mix employed will only support a 2.3 surface DOS. When Clark and Fowler² extended the nitration time to 1 hour at -25°C , no bulk nitration was observed. However, at -25°C this is not surprising since technical acid mixes are very viscous and penetration of the cellulose bulk by the acids is difficult to envisage.

At -15°C technical mixed acids are still viscous and therefore the penetration of the bulk cellulose, by the nitrating mix, may well still be incomplete even after 3 hours immersion. The bulk nitration of cellulose is now further considered in some detail; some aspects of surface nitration are covered in Section 4.3.6.

4.3.5 The Bulk Nitration of Cellulose with Technical Mixed Acids maintained at Low Temperature.

The nitration of cellulose papers in a technical mixed acid of the composition $75\% \text{H}_2\text{SO}_4$, $22.5\% \text{HNO}_3$, $2.5\% \text{H}_2\text{O}$, has been investigated at room temperature and at -15°C . At -15°C the acid mix was very viscous and hence nitration in the bulk of the cellulose was found to proceed very slowly as penetration of the acid mix into the cellulose was very slow. Complete penetration of the cellulose by the acid mix (i.e. complete nitration) was determined by the solubility of the nitrated product in d_6 -dmsO. A cellulose nitrate is only 100% soluble in dmsO when its DOS > 1.9 . From ^{13}C nmr it has been established that in a cellulose nitrates of DOS > 2 most of the glucose residues are at least mono-nitrated; hence, at 100% solubility it is fairly certain that complete penetration of the acid mix throughout the cellulose fibrils has occurred. At -15°C immersion times of greater than 10 hours were found to be necessary before complete solubility of the cellulose nitrated occurred. In Table 4.4 the surface and bulk DOS from

room temperature and low temperature (-15°C) nitration are compared.

Table 4.4 DOS from Nitration at +22°C and -15°C

Temperature	DOS	
	Surface	Bulk
22°C	2.35	2.8
-15°C	2.45	2.8

It can be seen from this table that both the surface and bulk DOS of the two materials are comparable (although the surface and bulk DOS for each individual cellulose nitrate are not the same - a full explanation for this is contained in Chapter 3). It is worthwhile noting that the cellulose nitrate prepared at low temperature appears to have a slightly greater surface DOS than that of the cellulose nitrate prepared at room temperature, however from the work in Chapter 2 it can be seen that the increase in DOS observed (0.1) for the surface and bulk is still, possibly, within the limits of experimental error.

The use of x-ray diffraction to investigate the crystal structure of cellulose nitrate has been reviewed in Chapter 1. Briefly, there exists a correlation between the angle of scattering θ from the d_{101} plane and the %N of the cellulose nitrate; it has been observed that the d_{101} spacing increases with an increasing %N in the cellulose nitrate.^{10,11} It is worth adding that the spacing of the d_{012} and d_{002} planes in the cellulose nitrate do not share the same sensitivity to the %N (DOS) of the material. The x-ray diffraction scans from 4° in

20 to 30° in 2θ for the two materials are displayed in Figure 4.10. From this figure it can be seen that the d₁₀₀ spacings in the 2 cellulose nitrates are the same.

The use of ¹³C nmr to probe the substitution distribution of nitrate groups in the anhydroglucose residues is described in Chapter 2. Analysis of the nmr spectrum is now considered. Band assignments are made on the basis of those described by Clark and Stephenson.⁶ The spectrum shown in Figure 4.11 is of a cellulose nitrate prepared in a 61% H₂SO₄, 24.5% HNO₃, 14.5% H₂O acid mix at room temperature. The components at 103.5 and 102 ppm have been assigned to C₁ in 3,6 disubstituted and 6-monosubstituted residues respectively. The components at 99.7 and 98.4 are (unusually) well resolved and assigned to the anomeric carbon in the trisubstituted and 2,6 disubstituted residues respectively. The component at 84.5 ppm arises from C₃ in 3,6-disubstituted residues whilst the peak at 82.9 ppm corresponds to C₂ in 2,6-disubstituted glucose residues. The Nuclear Overhauser Effect (NOE)¹² for C₁-C₅ have been shown to be essentially the same⁶ and therefore it is possible to directly ratio the peak areas for the disubstituted products. When the total integral for the low field region of the anomeric carbon and the area ratios for the two high field peaks are taken into account it becomes possible to work out the partial degree of substitution at the C₂, C₃ and C₅ positions and the substitution distribution for the cellulose nitrate.

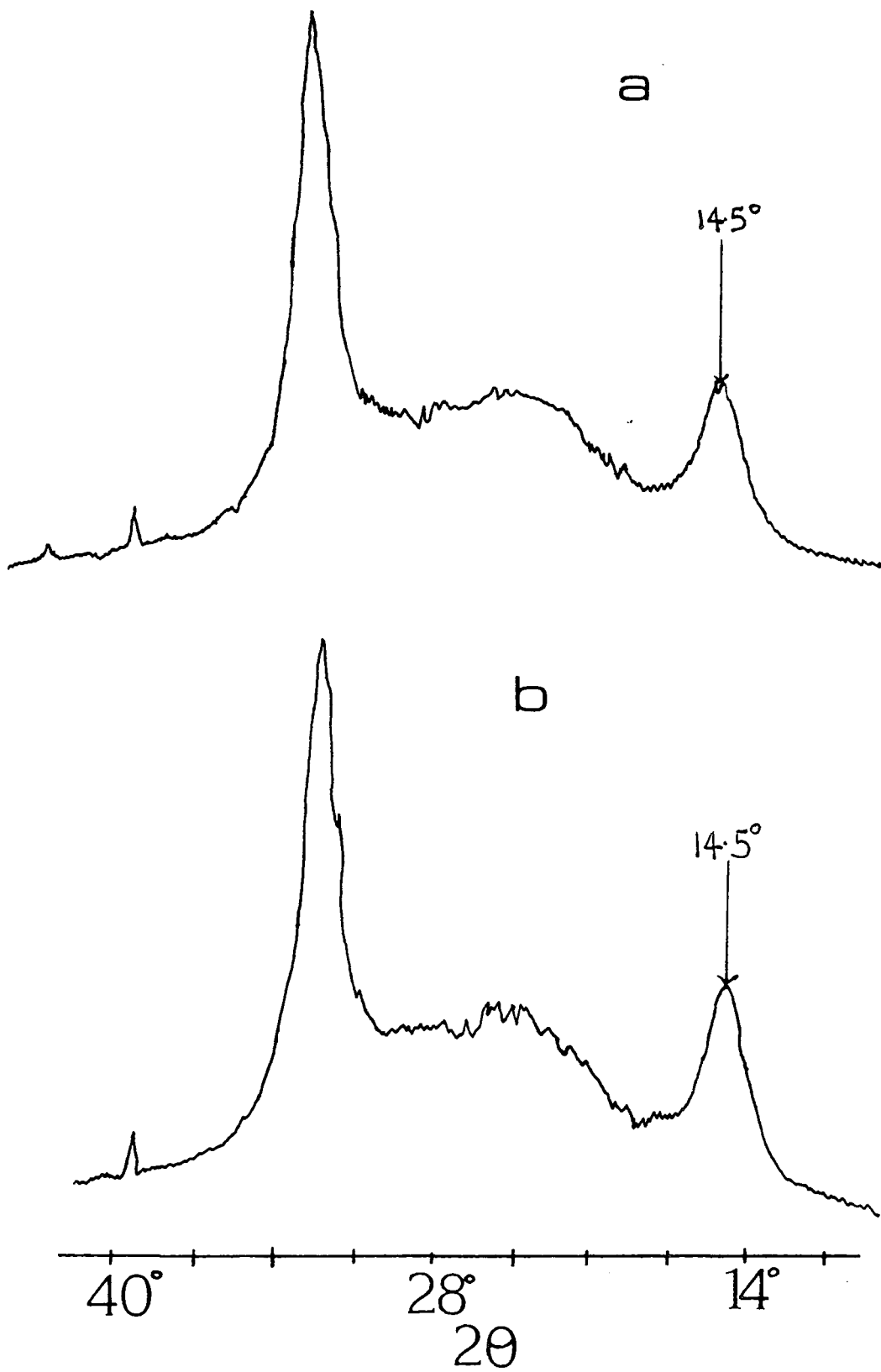

Figure 4.11 X-ray Diffractograms of Nitrated Celluloses
(a) Prepared $+20^\circ\text{C}$, (b) Prepared -15°C .

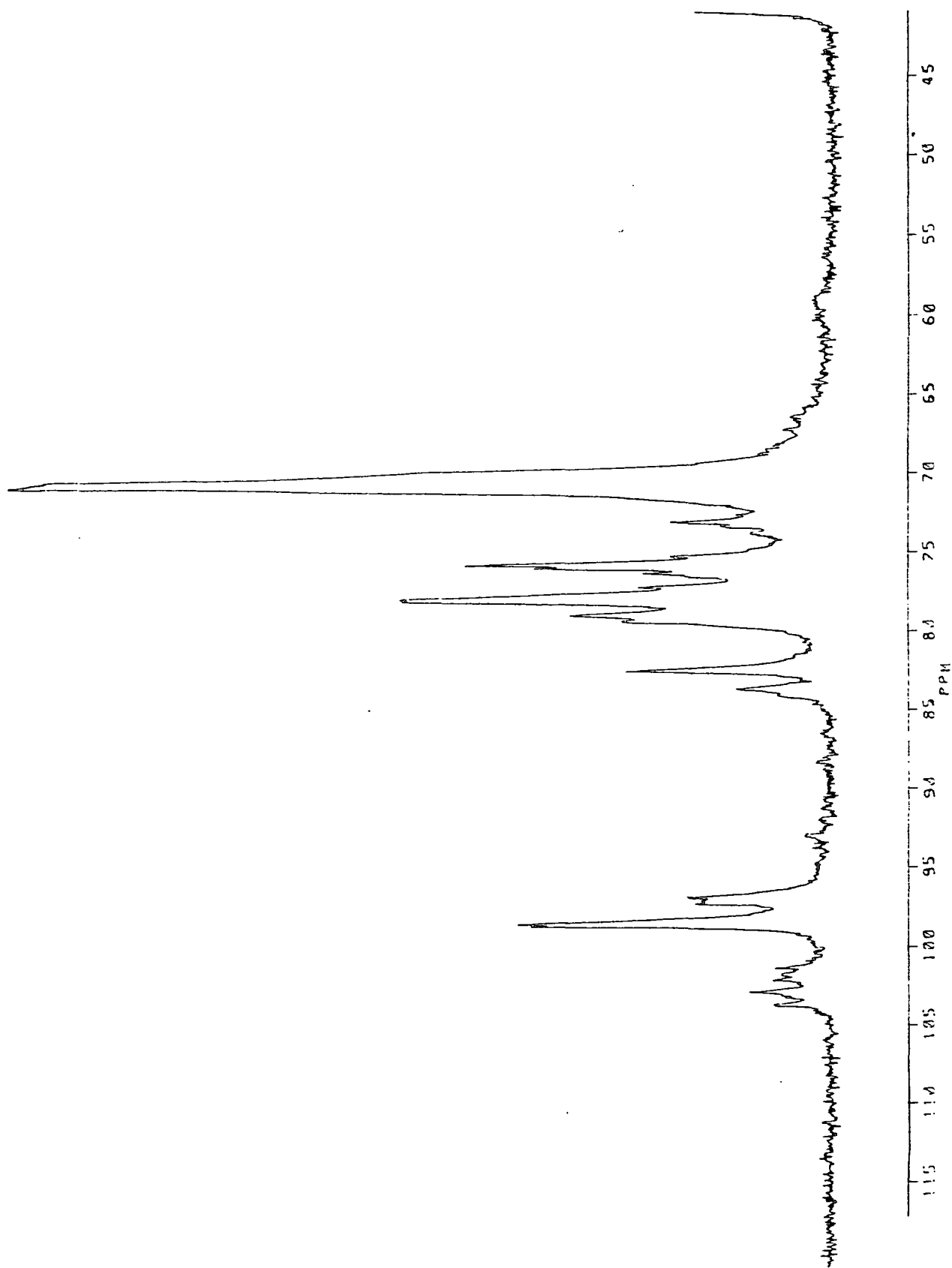
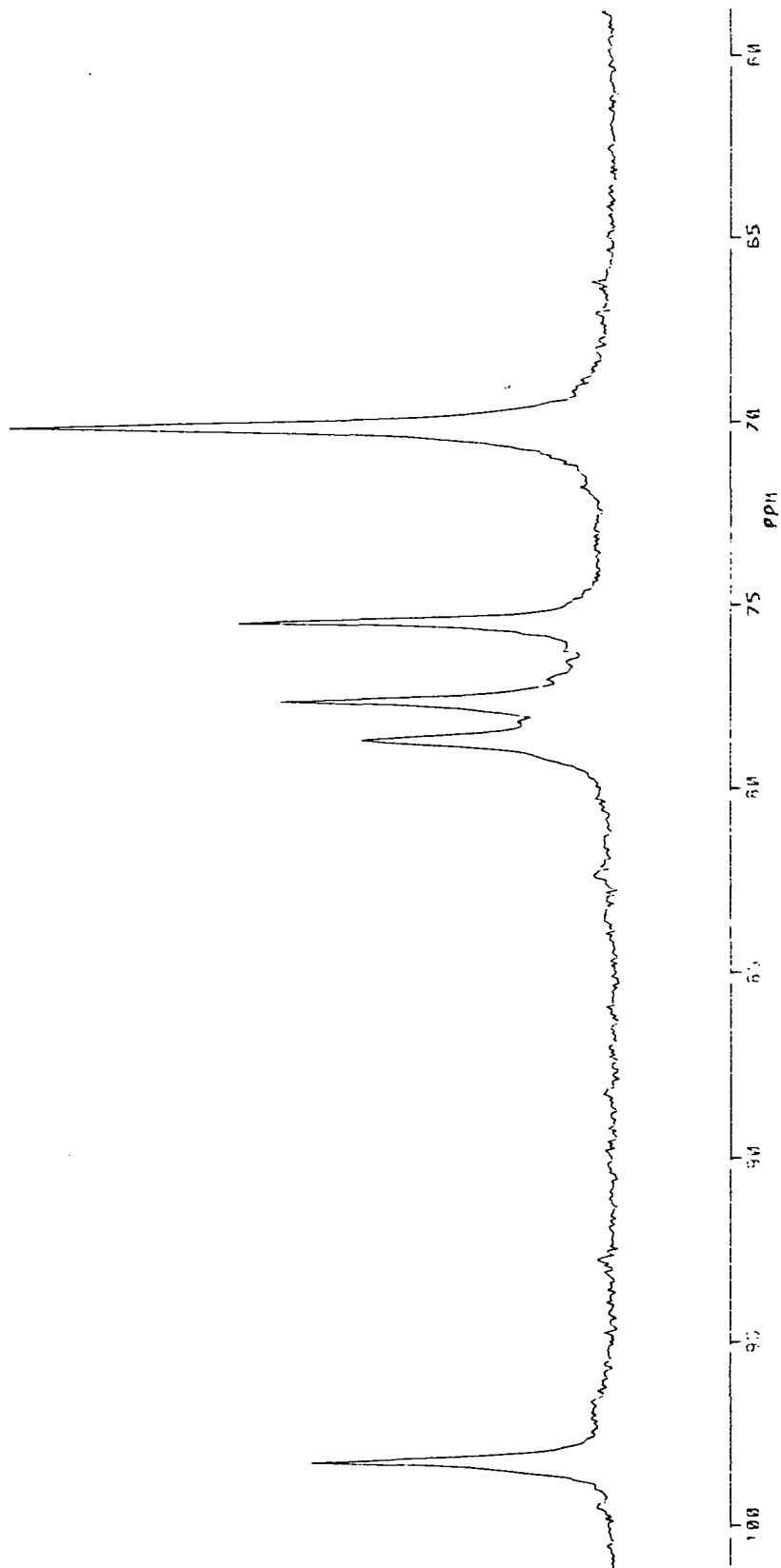

Figure 4.11 ^{13}C nmr Spectra of a 2,4 DOS Cellulose Nitrate.

The intense components at 79.5, 78 and 76.5ppm have been assigned to C₃, C₄ and C₂ in the trisubstituted residue: these assignments are confirmed by running the spectra of the trinitrate, see Chapter 6. The minor component at 73.9 ppm arises from the C₂ in the 3,6 disubstituted residue and its intensity is the same as the peak at 84.5ppm as required by this assignment. The intense peak at 70.9 ppm corresponds to C₆ nitrated material (shift insensitive to remaining substitution pattern) and to C₅ which is coincident in frequency. The peak at 60.5 ppm has been assigned to C₅ in unsubstituted glucose residues. The NOE for the methylene C₅ was estimated to be 1.5 by the analysis of the spectra for known DOS cellulose nitrates.

The solution state ¹³C nmr spectra of the two cellulose nitrates, Table 4.4, were run. The spectra are displayed in Figures 4.11 and 4.12. From visual examination of the figures it is clear that the ester functionalities are similarly distributed in the 2 cellulose nitrates.



Figures 4.12 ^{13}C nmr Spectra of Cellulose Nitrate prepared at +20°C.

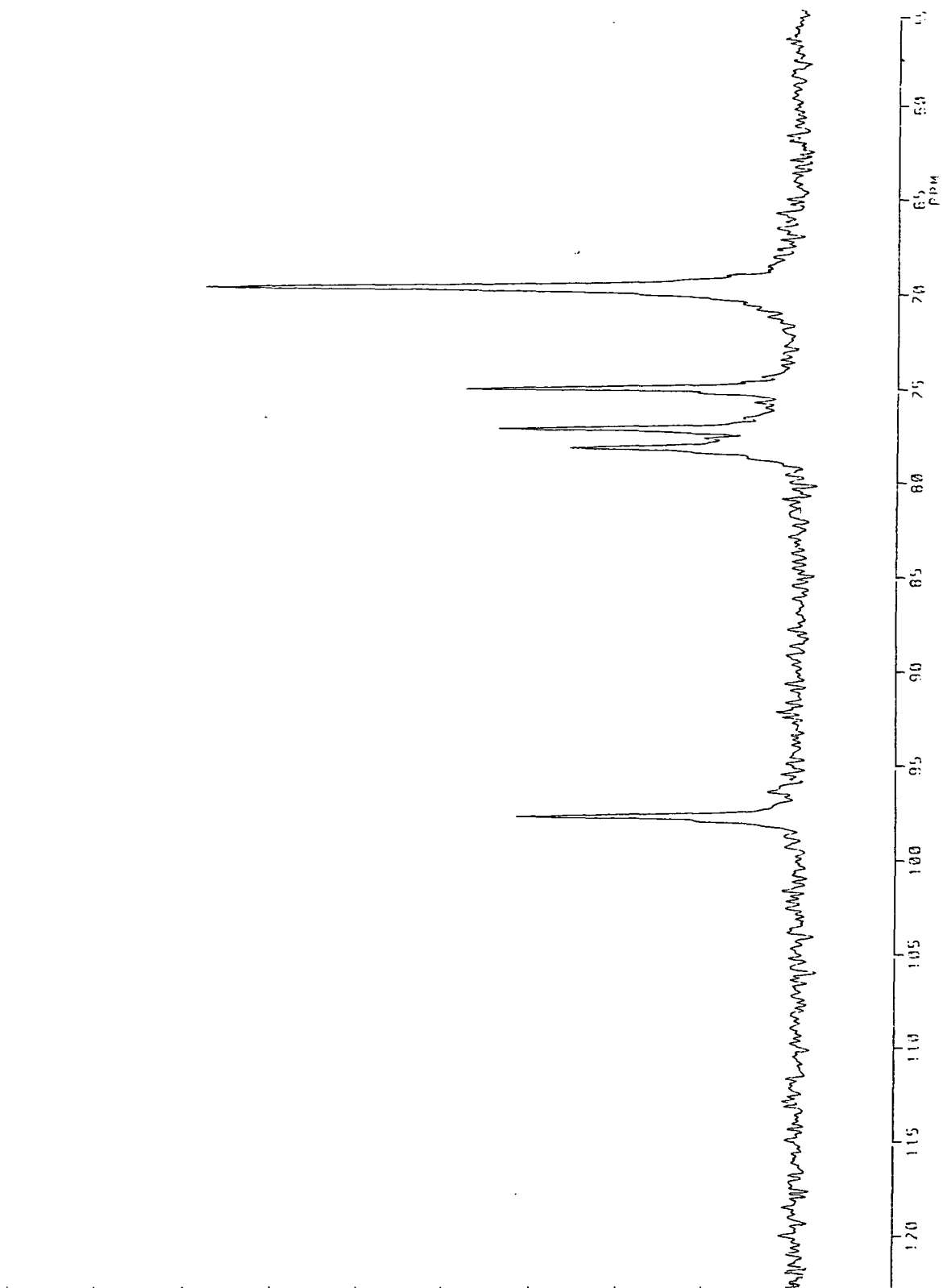
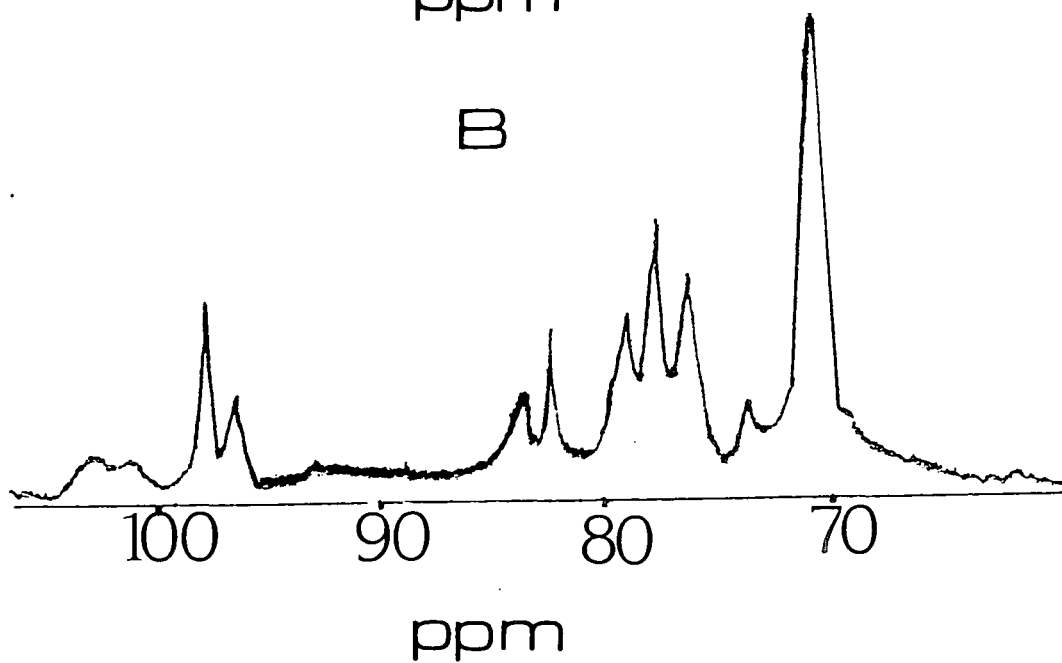
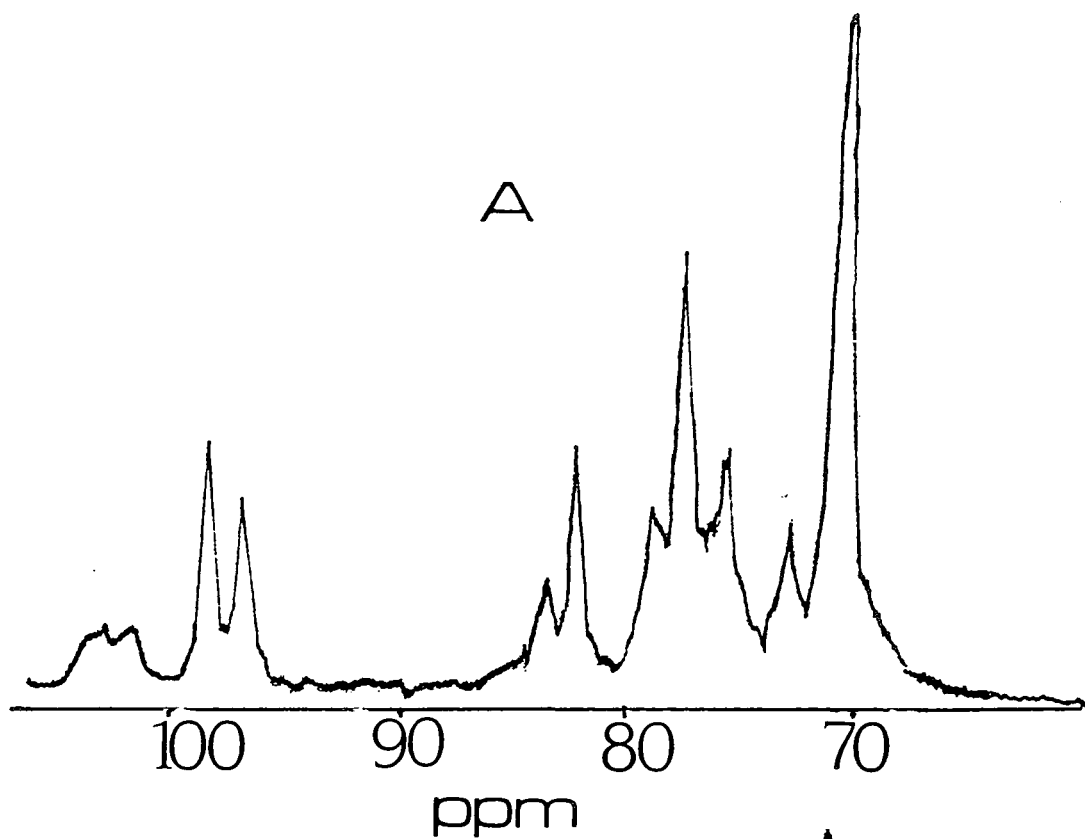

Figure 4.13 ^{13}C nmr Spectra of Cellulose Nitrate prepared at Low Temperature

Displayed in Figures 4.14 and 4.15 are the solution state ^{13}C nmr spectra of cellulose nitrates prepared in a 65% H_2SO_4 , 23.1% HNO_3 , 11.9% H_2O acid mix at room temperature and -15°C . As above, the substitution distribution in these two materials prepared at different temperatures are very similar.



Figures 4.14 and 4.15 (A) Cellulose Nitrate prepared at +20°C. (B) Cellulose Nitrate prepared at Low Temperature

4.3.6 Surface Nitration in Mixed Acids at Low Temperature

In technical mixed acids, at room temperature, the equilibrium DOS is established in the surface region to a depth of at least one hundred Angstroms in the first second of immersion. The rate of nitration in mixed acids maintained at low temperatures does not, from the DOS values in Figure 4.1, appear to be anywhere near as rapid. However, the curves in Figure 4.1 have been shown not to be representative of the equilibrium DOS. To gain a better understanding of the processes taking place at the cellulose surface that might have produced these curves, ESCA has been employed to follow the surface nitration of cellulose papers with time: nitrations in a 75% H₂SO₄, 22.5% HNO₃, 2.5% H₂O technical mixed acid were carried out at -15°C. The results are displayed in Table 4.5.

Table 4.5 Surface DOS with Time: Nitration at -15°C.

Time (seconds)	DOS
5	1.45
20	1.50
120	0.96
300	1.21
1620	2.29
6540	2.32
10200	2.36
2.5 days	2.28

From this table it can be seen that nitration in the surface region is extremely rapid, after 5 seconds the surface DOS reached is 1.45. However, the overall behaviour of DOS with time is unexpected and initially seems to be incompatible with the laws of mass action.

A drop in surface DOS at extended nitration times has already been reported by Fowler at room temperature.¹³

The time interval t=0 minutes to 4 minutes was investigated more closely with many more sampling points taken, Table 4.6.

Table 4.6 Surface DOS with Time: Nitration at -14°C

<u>Time</u> seconds	<u>DOS</u>
<5	2.00
10	1.80
12	1.45
20	1.40
120	1.15
240	0.95

From the above table it can be seen that at t<5 seconds a very high DOS is observed at the cellulose surface. However, at t=4 minutes the surface DOS is only half the value of t<5 seconds. The cellulose nitrates produced after immersion times of greater than 5 seconds were noticed to be extremely brittle and consequently very difficult to mount on a probe tip prior to analysis by ESCA. The brittleness can perhaps be

attributed to stresses imposed in the material by the limited nitration of the surface. X-ray diffraction studies^{14,15} have shown that the dimensions of the unit cell of cellulose nitrate are larger than those of the cellulose unit cell: it is not unreasonable to assume that the accommodation of these two different unit cells in one material will produce considerable stress, i.e. brittleness.

The DOS presented in Table 4.6 provides information on the level of nitration in, approximately, the top 50Å of the cellulose. It is very unlikely that the 'overall' level of nitration in the cellulose drops after 5 seconds immersion. However, it seems reasonable to assume that the cellulose fibre structure is undergoing considerable re-organization with nitration and ESCA is monitoring the effects of this 're-organization' in the fibre structure in the top 50 Å. Employing Scanning Electron Microscopy (SEM) the surface of the cellulose fibres have been examined at 2 different nitration times (Plates 1 and 2).

Visual examination of the micrographs taken reveals 'cracking' in the fibre surface as nitration proceeds. However, the original cellulose fibres were 'pitted' and therefore the cracking phenomena is not as obvious in these plates as it is in the micrographs of nitrated cellophane presented in Chapter 2. From the Plates it is evident that destruction of the fibre surface is concomitant with nitration.

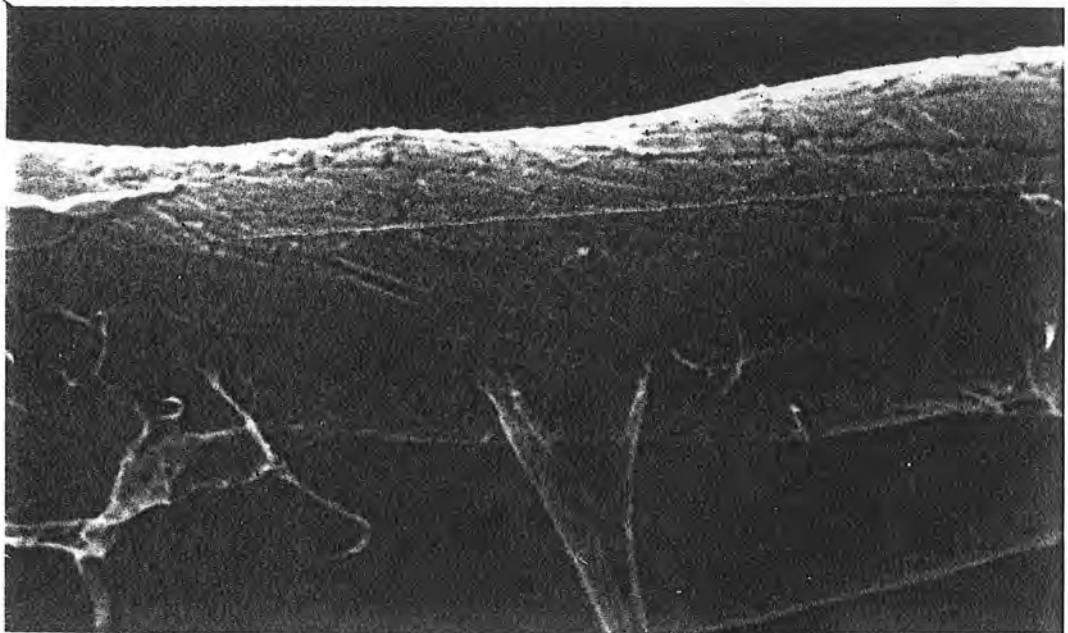

4 μ

Plate 1 SEM of Cellulose Fibre after 5 Seconds Nitration.

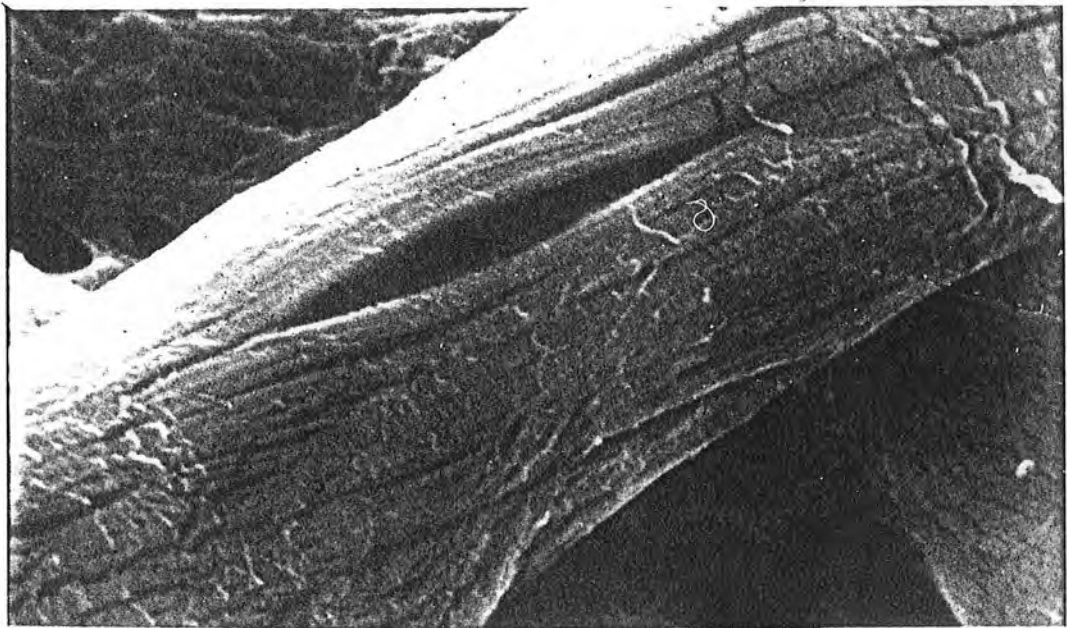

4 μ

Plate 2 SEM of Cellulose Fibre after 2 Minutes Nitration.

It is envisaged that the fibre cracking results from stresses imposed, by nitration, in the cellulose surface. Fibre splitting will present a new cellulose surface to the nitrating mix; when the nitration is quenched immediately and the nitrating mix washed away, the cellulose surface monitored by ESCA will consist of nitrated cellulose and the new unsubstituted cellulose surface. At $t < 5$ seconds no cracking is observed in the SEM micrographs of the cellulose fibres. At $t > 5$ seconds the onset of splitting occurs and the nitrated materials become brittle; the surface DOS monitored drops.

The severity of the cracking observed, is most probably heightened by quenching when nitration is limited to the very surface and by the temperature gradient which exists between the nitrating mix, -15°C , and the cellulose, $+22^{\circ}\text{C}$. It has proved impossible to cool the cellulose below 0°C and keep its moisture content low.

The cracking phenomena reported above is similar to that observed in cellophane at room temperature (Chapter 2). However, in cellophane the cracking is a lot more severe and not limited to the surface. Fully nitrated cellophanes are still extremely brittle. Above, the fully nitrated materials are not at all brittle.

In Section 4.3.1 different methods for quenching the nitration reaction, at low temperature, were discussed. It is clear from the discussion above, that buchnering of the sample prior to quenching will suck the

acid through the cellulose material and therefore give rise to nitration in the fibre cracks. Hence, the difference in surface DOS obtained by the two methods.

At room temperature, it is anticipated that fibre cracking can be observed in the initial stages of nitration. Because at room temperature, the acid mixes are considerably less viscous than at -15°C , the rate of diffusion of the acids into the cellulose subsurface will be very much faster. This clearly is an important factor in determining the extent of cracking that is observed. The surface nitration of cellulose papers in a 75% H_2SO_4 , 22.5% HNO_3 , 2.5% H_2O acid mix has been monitored as a function of time, the results are presented in Table 4.7. The nitration was quenched immediately.

Table 4.7 Surface DOS with Time: Nitration at $+22^{\circ}\text{C}$

Time of nitration (seconds)	DOS
1	2.05
15	1.90
60	2.30
420	2.25
2400	2.38

From the table it is evident that the predicted dip in DOS can be observed at $t=15$ seconds but it is neither as dramatic nor as persistent as reported in low temperature nitrations.

The cracking phenomena has been observed in different composition acid mixes and in other nitrating systems; it manifests as a dip in the DOS monitored by ESCA during the initial stages of nitration. For examples, see chapter 2 where cracking is observed in a 65% H_2SO_4 , 22.5% HNO_3 , 12.5% H_2O acid mix or Chapter 5, figures 5.4 and 5.5, where cracking is observed for nitration in nitronium ion salts.

4.3.7 Summary

In this chapter it has been shown that the nitration-denitration equilibria established between cellulose and mixed acids (Chapter 3) do not have the envisaged temperature dependence, as previously reported. At low temperature, nitration in the surface region occurs on a similar time scale to nitration at room temperature. Bulk cellulose nitration requires much longer immersion times because of the increased viscosity of the acids. The DOS vs temperature curves reported by Clark and Fowler do not represent final DOS and are shown to be produced as a result of cracking in the fibre surface (re-organization of the fibre structure with nitration).

REFERENCES

- 1 D.T. Clark and P.J. Stephenson, *Polymer*, 1982, 23, 1034.
- 2 D.T. Clark and A.H.K. Fowler, *Polymer Comm.*, 1983, 24, 140.
- 3 D.T. Clark, H.S. Munro and A.H.K. Fowler in 'Cellulose and its Derivs.', Ellis-Horwood, Chichester, 1985.
- 4 A.H.K. Fowler, Ph.D. Thesis, 1984, University of Durham.
- 5 Calverts according to Miles in 'Cellulose Nitrate', Interscience, London, 1955.
- 6 E. Berl and R. Klays, *Z. Scheiss Srengstoff*, 1907, 403.
- 7 C.K. Ingold in 'Structure and Mechanism in Organic Chemistry', Bell, London, 1953.
- 8 D.T. Clark, P.J. Stephenson, F. Healey, *Polymer*, 1982 23, 1112.
- 9 D.T. Clark, P.J. Stephenson, *Polymer*, 1982, 23, 1295.
- 10 J. Trommel, Comm. No. 13, N.V. Koninklijke Nederlandsche Springstoffenfabrieken, Amsterdam.
- 11 F.D. Miles, *J. Phys. Chem.*, 1930, 34, 2607.
- 12 J.H. Noggle and R.E. Schirmer, *The Nuclear Overhauser Effect, Chemical Applications*, Academic Press, New York, 1971.
- 13 A.H.K. Fowler, Ph.D. Thesis, 1984, University of Durham.
- 14 A. Sarko in 'Wood and Cellulosics', Ellis-Horwood, Chichester, 1987.
- 15 E.D.T. Atkins, *Polymer*, 1978, 19, 1371.
- 16 F.D. Miles, 'Cellulose Nitrate', Interscience, London, 1955.

CHAPTER FIVE - THE NITRATION OF CELLULOSE WITH
NITRONIUM TETRAFLUOROBORATE

5.1 INTRODUCTION

In the previous chapters the preparation of cellulose nitrate in mixed acids has been investigated and the problem of limiting DOS tackled. The DOS at the very surface of the cellulose fibre has been shown to be equilibrium controlled and this result has important consequences when considering the control of DOS in the cellulose fibre. The accessibility theory is no longer tenable when attempting to explain the limiting DOS in technical mixed acids (2.77). The preparation of a fully substituted cellulose nitrate in technical mixed acids is not possible because of the denitrating action of the sulphuric acid component of these mixes.

However, a wide variety of other nitrating mixes have been employed to nitrate cellulose to a very high DOS.^{1,2} The use of the nitronium ion salt, nitronium tetrafluoroborate, to nitrate Whatman No.1 papers, was briefly described in Chapter 3 where it was shown that a very high surface DOS can be achieved nitrating in a saturated solution. To the authors' knowledge this is the first time the nitration of cellulose with a nitronium ion salt has been reported. Many details of the experiment reported in Chapter 3 were omitted for the sake of simplicity.

The first reported preparation of a nitronium ion salt was by Hantzsch.³ The product $\text{H}_2\text{NO}_2^+(\text{ClO}_4^-)_2$ was obtained from mixtures of anhydrous nitric acid and perchloric acid, which could then be separated by

fractional crystallization from nitromethane into $\text{NO}_2^+\text{ClO}_4^-$ and $\text{H}_3\text{O}^+\text{ClO}_4^-$. The nitronium salt can be obtained pure and its structure has been determined by X-ray crystallography.⁴ Investigation of the Raman spectrum of this compound established unequivocally the existence of the nitronium ion in many of the media used in nitration.

Nitronium Tetrafluoroborate was first prepared by Olah et al⁵ by adding mixtures of anhydrous hydrofluoric acid and boron trifluoride to a solution of dinitrogen pentoxide in nitromethane.

Nitronium salts are colourless, crystalline and generally very hygroscopic. The fluoro-salts are relatively stable, perchlorate and sulphate salts are unstable and liable to spontaneous decomposition.

Cryoscopic investigations suggest that in sulpholan $\text{NO}_2^+\text{BF}_4^-$ exists predominantly as ion pairs.⁶

The selection of suitable solvents for quantitative work is not easy. Nitroalkanes are inert, but nitronium tetrafluoroborate is poorly soluble in them. Sulpholan is usually employed as a solvent and solutions of $> 0.5\text{mol l}^{-1}$ (20°C) can be prepared. Nitronium salts in sulpholan have been commonly employed in kinetic and mechanistic studies of organic nitrations.⁵⁻¹⁰

There are several advantages to be gained from studying the nitration of cellulose with nitronium salts. For example, the concentration of the nitronium ion in technical mixed acid has only been estimated qualitatively from Raman Scans by comparing the relative

peak intensities of the nitronium ion and the nitric acid bands*; the exact concentration of the nitronium ion in salt solutions is known, hence kinetic studies of nitration become feasible.

The instability of cellulose nitrates prepared from mixed acids, to $Mg_{K\alpha}$ x-rays and thermal radiation, has been credited to the residual acids trapped in the cellulose fibre and to sulphate esters (that are not removed by boiling). This hypothesis can be potentially tested by comparing the stability of materials prepared in mixed acids to those prepared from nitronium ion salts.

The nitronium ion has unambiguously been shown to be the effective nitrating agent of cellulose in mixed acids. In this chapter the action of nitronium salts on cellulose are investigated. For this work ESCA, X-ray diffraction and Raman spectroscopy were employed.

* The concentration of the nitronium ion in mixed acids has been determined by Infra-red and Raman spectroscopy¹¹.

5.2 EXPERIMENTAL

Whatman No.1 papers and cellophane sheets were used in this study. Preparation of the cellulose prior to nitration is outlined in section 2.2.

Nitronium tetrafluoroborate (99% Aldrich Chemical Co.) was dissolved in sulpholan.

Nitrations were carried out in a dry box under a dry nitrogen atmosphere. The relative humidity was typically 5-7%. Nitrations were quenched in 1 litre of cold water, introduced into the dry box in a sealed vessel.

Nitromethane (99.5% Aldrich Chemical Co. 'Gold Label') was employed as a solvent for the nitronium tetrafluoroborate crystals. The nitromethane was dried over a 5Å molecular sieve and silica gel.

Samples were boiled for 5 minutes to remove any oxidation products of nitration. Samples were dried and then soxhlet extracted to remove sulpholan from the cellulose surface.

ESCA spectra were run on a Kratos ES300 electron spectrometer.

X-ray diffraction, see Section 2.2, was employed to measure the d_{101} spacings in the nitrated materials.

The Raman scan of the 0.5 molar nitronium tetrafluoroborate solution was run on a Varian Cary 82 Raman Spectrophotometer using an Argon gas laser (514.5nm, 200mW).

5.3 RESULTS AND DISCUSSION

5.3.1 Surface Contamination

In this section the problem of extraneous surface contamination is considered. In Figure 5.1 the C_{1s} and N_{1s} core levels are presented for a piece of cellulose paper nitrated for 20 hours in a 0.5 molar solution of nitronium tetrafluoroborate in sulpholan at 20°C. It is clear from the C_{1s} core level that there is a very high level of extraneous hydrocarbon on the surface. The nitrated cellulose is yellow on removal from the nitronium ion salt and it retains this colour after a brief wash in water followed by pentane. Surface analysis, S_{2p} core level, has shown the contamination to be associated with sulpholan adhering to the cellulose nitrate surface. Despite the very high level of hydrocarbon monitored, the DOS observed is 2.4 - 2.5.

Any adhering sulpholan can be removed by soxhlet extraction with either petroleum-ether, a hexane/pentane mix or dichloromethane (all proven non solvents of cellulose nitrate). In Figure 5.2 the C_{1s} and N_{1s} core levels are presented after soxhlet extraction of the material in Figure 5.1. The surface DOS calculated from Figure 5.2 is 2.4; hence it is evident that the high level of hydrocarbon in Figure 5.1 has not seriously attenuated the N_{1s} signal. Considering the discussion presented in Chapter 2 on the effects of contamination on the DOS monitored by ESCA, it is clear that the hydrocarbon in Figure 5.1 does not exist as a uniform

overlayer. The hydrocarbon contamination observed must be 'sitting in' the cellulose nitrate surface.

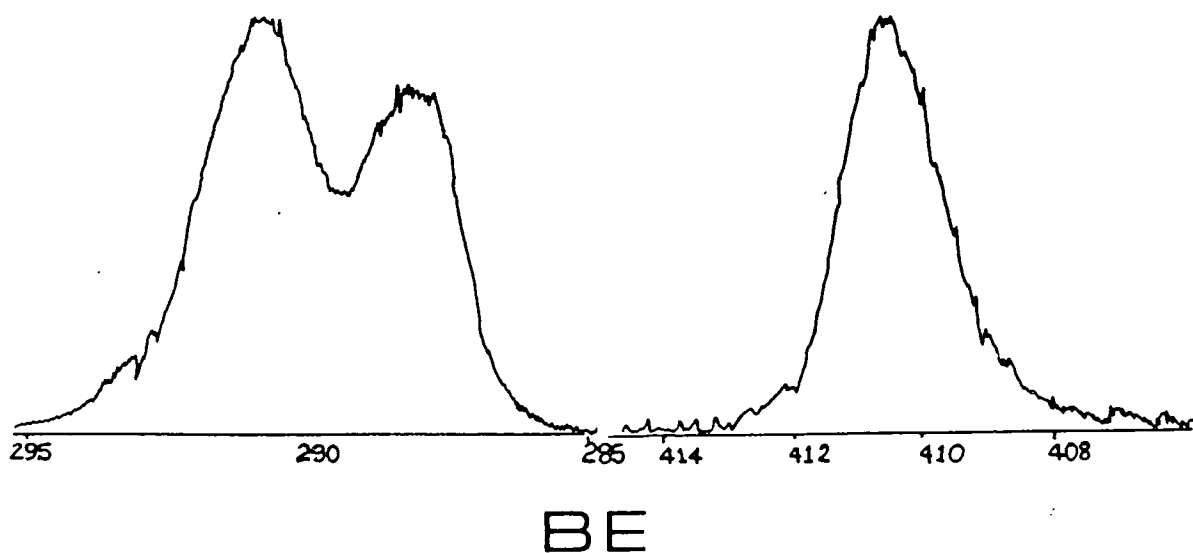

Figure 5.1 C_{1s} and N_{1s} Core Levels prior to Soxhlet Extraction.

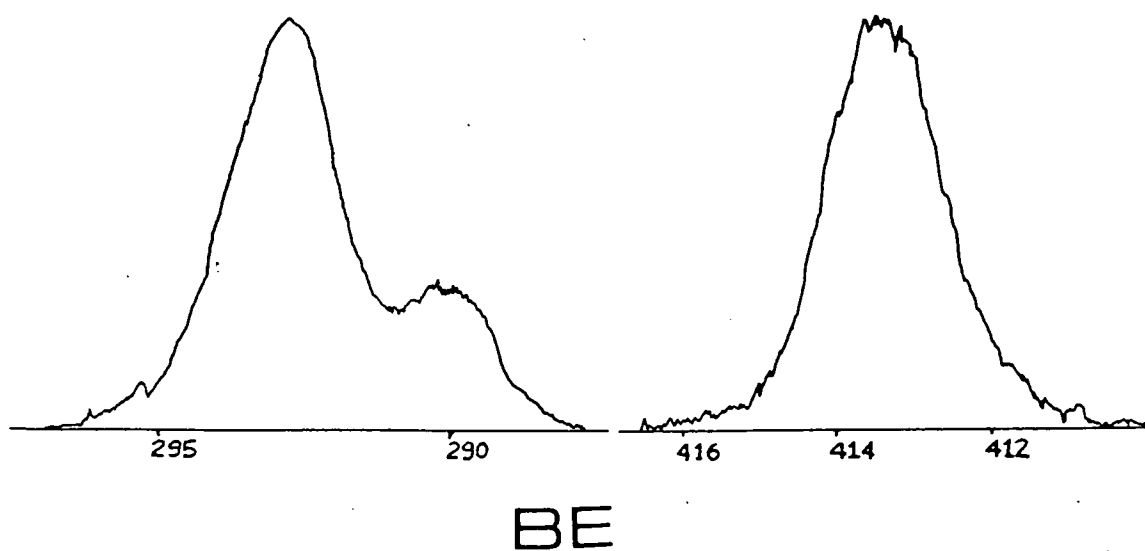

Figure 5.2 C_{1s} and N_{1s} Core Levels after Soxhlet Extraction.

5.3.2 A Study of Surface and Bulk Nitration.

The surface DOS obtained from this experiment is of interest. In Chapter 3 it has been shown that the nitronium ion salt is the important nitrating species in mixed acids and DOS increases with increasing nitronium ion concentration. This observation is limited at high sulphuric acid concentrations where the action of this acid prevents complete nitration, i.e. DOS = 3 being reached. In a nitronium ion salt it was expected that complete nitration would be achieved. This expectation is not realized; from Figure 5.2 it can be seen that a DOS of 3 has not been reached in the cellulose surface after 20 hours nitration. Further, Kjeldahl analysis of the material reveals a nitrogen content of 0%. The x-ray diffractogram scan, from 4° in 2θ to 30° in 2θ , is presented in Figure 5.3 for a cellulose nitrated in a 0.5 molar mix. From the d_{100} spacing it is clear that no nitration has taken place intrafibrillarly.

Evidently the nitration observed by ESCA is limited to the very surface of the cellulose fibres (top 30 Å or so). In fact virtually no penetration of the cellulose by the nitronium ion salt has occurred and this can be appreciated from the data presented in Table 5.1 which refers to the DOS monitored by $Mg_{K\alpha}$ and the $Ti_{K\alpha}$ x-rays, sampling depths typically 30 Å and 100 Å.

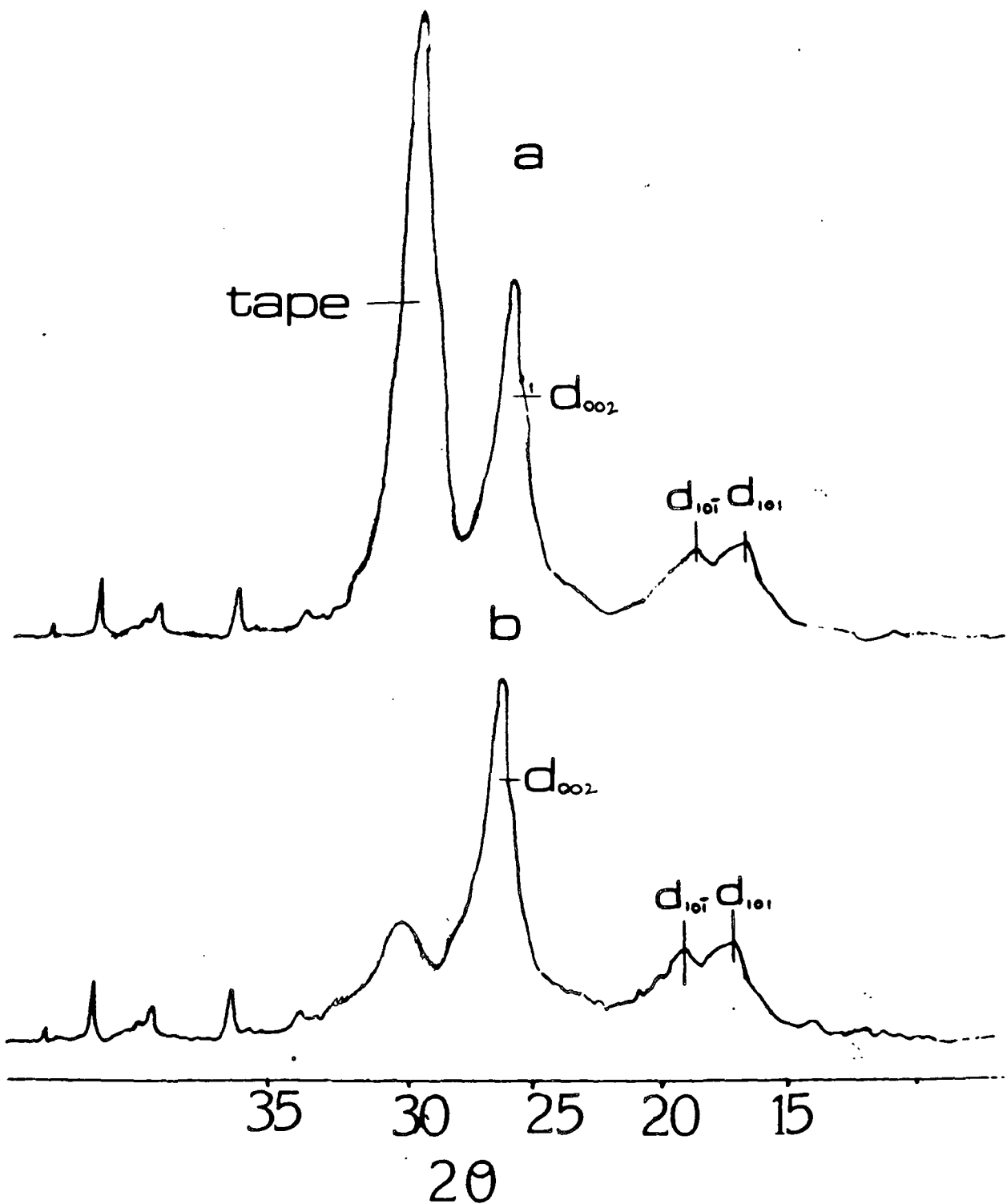

Figure 5.3 X-ray diffractograms of (a) cellulose (b) cellulose nitrated in a 0.5 molar nitronium ion salt.

Table 5.1 DOS monitored at different sampling depths.

Anode	Sampling Depth	DOS
Mg _{HClO₄}	30Å	2.37
Ti _{HClO₄}	100Å	1.07

It seems unlikely that nitration is homogeneous even in the top 30 Å and this hypothesis is supported by the data presented in Table 5.2. Table 5.2 refers to the nitration of a cellophane film in a 0.5 molar nitronium ion salt. Despite severe crinkling of the film on immersion in the nitrating mix it is clear that the DOS monitored is angular dependent.

Table 5.2 DOS monitored at different sampling depths.

TOA	DOS
70°	2.2
30°	1.8

The nitration of cellulose papers with nitronium ion salts appears to be limited by the penetrating ability (or lack) of the nitrating mix. The ability of a nitrating mix to swell cellulose is important if nitration is to take place inter- and intrafibrillarly. Swelling in cellulose can be achieved by treatment with various polar liquids, the extent of swelling can be determined from optical microscopy and x-ray diffraction.¹⁰ The effect of soaking cellulose in sulpholan has been investigated. Cellulose papers were soaked for 24 hours in dry sulpholan at 20°C. The 'wet'

papers were then examined. Visually and from optical microscopy no evidence of any fibre swelling was detected. The diffractogram of a soaked paper, Figure 5.4, shows that no intercrystalline swelling has occurred in the cellulose.

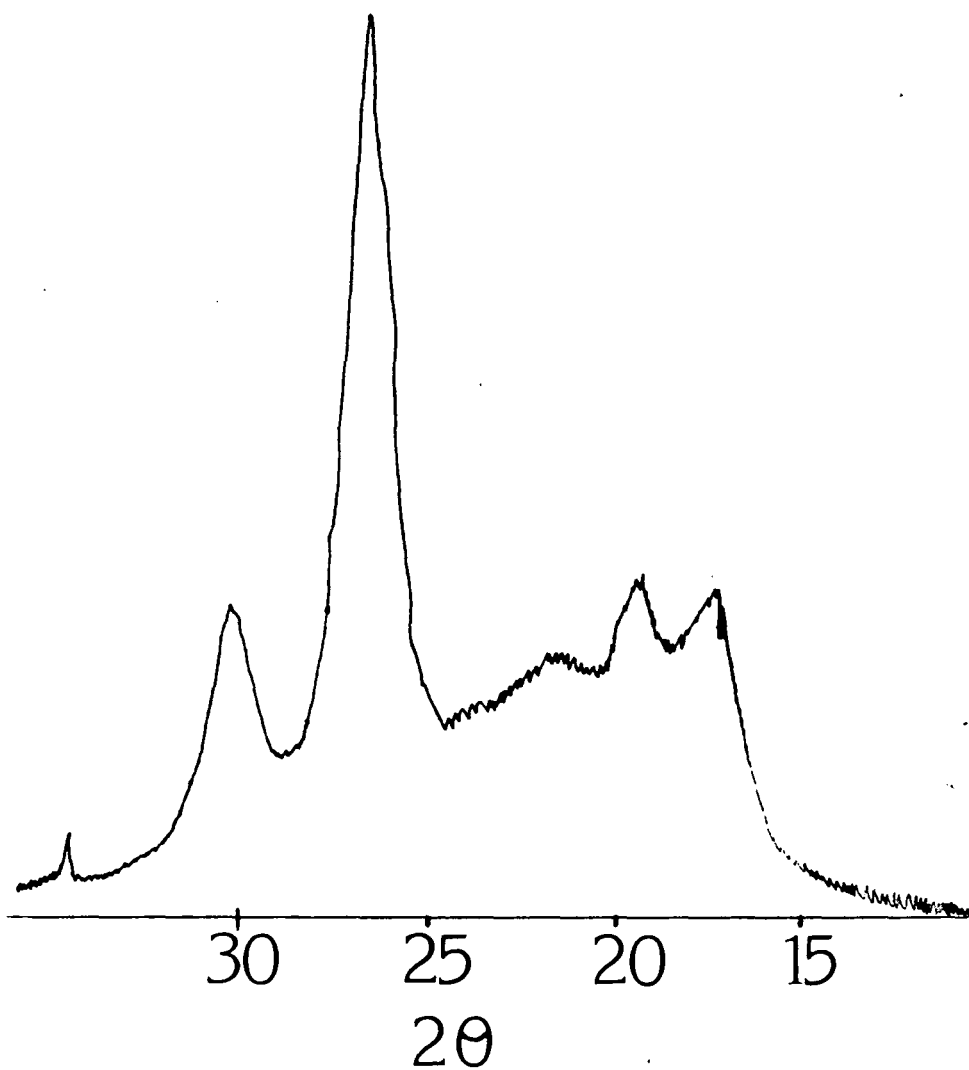

Figure 5.4 Diffractogram of Cellulose Soaked in Sulpholan cf. Figure 5.3 (a).

The effect of the nitronium ion concentration on the surface DOS achieved has been investigated. Final DOS is presented with nitronium ion concentration in Table 5.3.

Table 5.3 Surface DOS with Nitronium Ion Concentration.

Salt Concentration	Final DOS
0.21 molar	2.0
0.50 molar	2.4
Sat. Solution (20°C)	2.8

Table 5.3 shows that DOS increases with increasing nitronium ion concentration employed.

The source of cellulose employed probably has an important bearing on the surface DOS obtained; this has not been investigated.

It was envisaged that nitration of the fibre might well increase accessibility in the top 30Å to further nitration. A cellulose nitrate prepared from a phosphoric-nitric acid mix has been further nitrated in a 0.5 molar nitronium ion salt mix, the results are presented in Table 5.4.

Table 5.4 DOS with Successive Treatments.

	P_2O_5/HNO_3	Cellulose nitrate after 5 hours immersion in nitronium salt
Surface	2.55	2.9 - 3.0
Bulk	2.7	2.7

From the table it can be seen that immersion in the nitronium ion salt has no effect on the bulk DOS; extending the immersion time to 10 days still produces no change in the bulk DOS. However, immersion of the cellulose nitrate in the nitronium ion salt produces a surface DOS of 3.0.

Re-immersion of a cellulose nitrate directly back into the nitronium ion salt in which it was originally prepared, produces no change in surface DOS. However, if the cellulose nitrate is removed, washed and boiled in water, dried and then re-immersed the surface DOS increases appreciably, see Table 5.5.

Table 5.5 The Effect of Washing/Boiling on the DOS obtainable.

<u>Preparation</u>	<u>DOS</u>
a) 20 minute nitration.	2.4
b) 2 x 20 minutes nitration	2.4
c) 20 minute nitration, boil, further 20 minute nitration.	2.7

Soaking the material (a) in sulpholan and re-nitrating produced no increase in the surface DOS.

5.3.3 The Kinetics of Nitration.

It is not possible to carry out kinetic studies (analogous to those of Ingold et al¹¹) to elucidate the order and rate of cellulose nitration, in nitronium ion salt solutions, because of the heterogeneous nature of the reaction. However, it is possible with ESCA to follow nitration in the cellulose surface as a function of immersion time. In Figure 5.5 this has been carried out for the nitration of cellulose papers in a 0.21 molar solution of nitronium tetrafluoroborate in sulpholan at +22°C. From this figure it can be seen that nitration is initially rapid at the fibre surface. However, between 0-5 minutes there is a 'dip' in the DOS monitored. In Chapters 2 and 4 similar decreases in surface DOS have been reported: the dips are associated with cracking of the nitrating surface. The 'dip' observed in Figure 5.5 may well be the result of a similar fibre cracking phenomena. The final surface DOS obtained in this mix was 2.0.

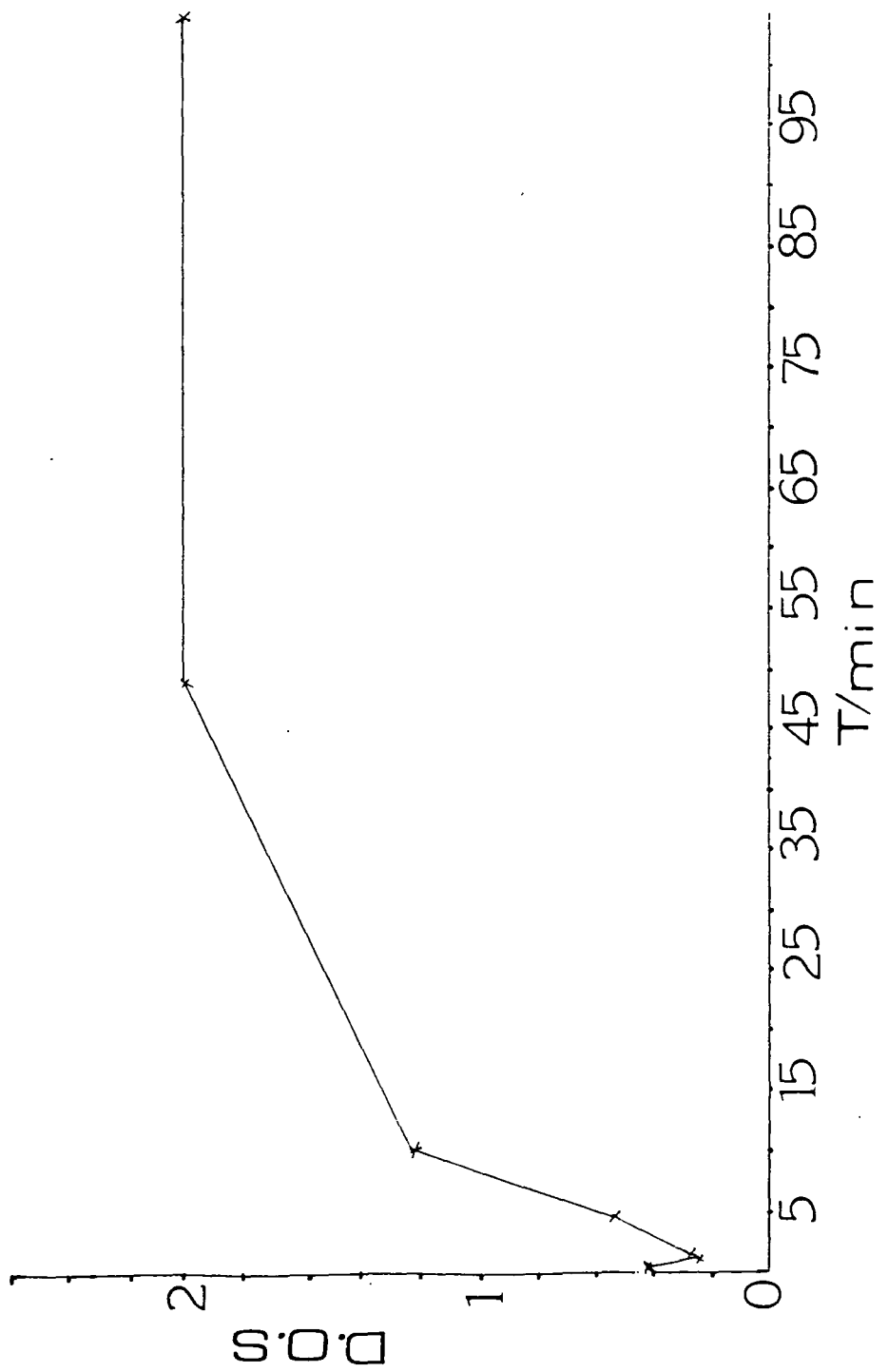

Figure 5.5 Surface D.O.S. with time for nitration in a 0.21 molar nitronium ion salt (20°C).

In Figure 5.6 surface DOS is presented as a function of time for nitration in a 0.5 molar nitronium ion salt solution. From this figure it can be seen that nitration proceeds more rapidly at the cellulose surface in this mix than in the 0.21 molar mix. In this mix no obvious 'dip' in DOS is observed. However, the increase in DOS observed with time is not smooth. From Figures 5.5 and 5.6 it can be seen that the rate of nitration in nitronium ion salt solutions is slow in comparison to the rate reported in technical mixed acids.

The 0.5 molar mix was examined by Raman Spectroscopy. The nitronium ion band, at 1400 cm^{-1} , was not spectroscopically detectable.

Again, from this work it is evident that the rate of surface nitration is controlled by the concentration of the nitronium ion in the nitrating mix.

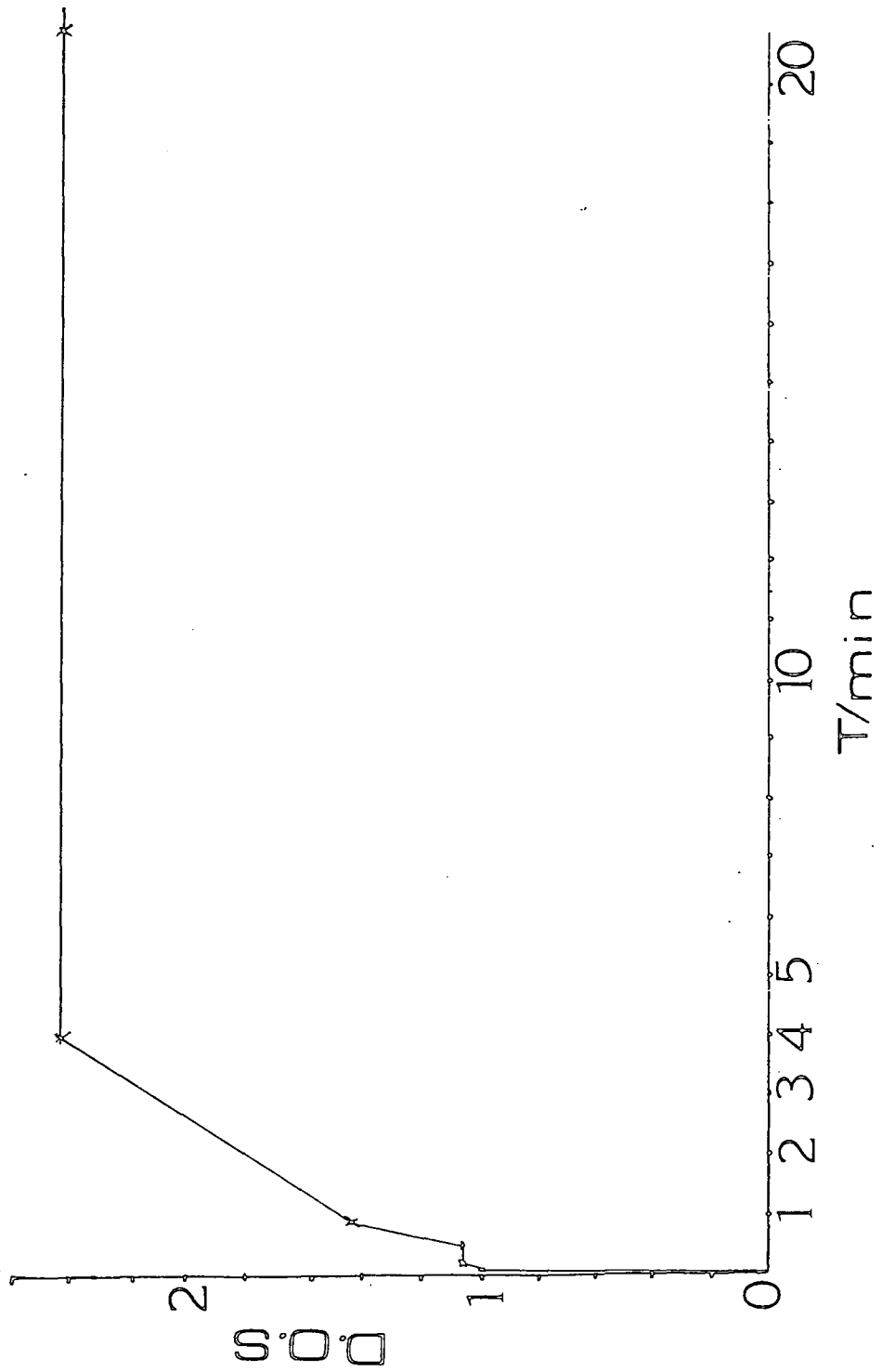

Figure 5.6 Surface DOS for nitration in a 0.5 molar nitronium ion salt as a function of time.

5.3.4 X-ray Stability

In Chapter 2 it was suggested that the reported instability of cellulose nitrates, prepared in mixed acids, to electromagnetic radiation could possibly be attributed to sulphuric acid or sulphate esters that are not removed, from the cellulose fibres, during stabilization.

The effect of thermal radiation has previously been shown to be bulk orientated which makes nitronium ion salt prepared cellulose nitrates unsuitable for thermal studies. However, the effect of higher frequency radiation, u.v and x - ray can be monitored at the fibre surface. The stability of a 2.4 surface DOS cellulose nitrate to $Mg_{K\alpha}$ x-rays has been monitored as a function of time. The loss in the intensity of signal from the nitrate peak and the exposure time necessary before the appearance of the low binding energy component, were found to be similar to those reported in Chapter 2 for cellulose nitrates prepared in mixed acids. In Chapter 6 the stability (thermal and x-ray) of cellulose nitrates prepared in 'sulphuric acid free' environments and those prepared with technical mixed acids are compared.

5.3.4 Nitronium Tetrafluoroborate in Nitromethane

The use of nitromethane as an alternative solvent to sulpholan is investigated in this section. Although the solubility of nitronium tetrafluoroborate in nitromethane is low, about 0.3% by weight,^{1,2} it was

thought that bulk nitration of the fibre might take place in this solvent. Ingold et al¹³ have shown nitromethane to be a more 'polar' solvent than sulpholan and polar solvents can cause swelling in the cellulose fibre.¹⁰

Cellulose paper was immersed in a saturated nitronium tetrafluoroborate/nitromethane mix for 24 hours. From the N_{1s} core level (408 eV- charge corrected) only a minimal level of nitration could be detected.

No nitrogen was detected in the bulk analysis of the treated paper. Clearly nitration is limited to the surface of the fibre and the low concentration of the ion limits the DOS achieved.

The ability of nitromethane to swell cellulose was investigated by x-ray diffraction. Dry cellulose papers were immersed in nitromethane for 24 hours, the papers were analysed 'wet'. From the d₁₀₁, d₀₁₂ and d₀₀₂ interchain spacings measured it was evident that nitromethane can not cause swelling in the crystalline regions of the fibre.

Summary

In this chapter it has been shown that although the nitronium ion salts can be employed to nitrate cellulose papers their use is limited. The common solvents of these salts can not swell the cellulose fibre and nitration is therefore restricted to the fibre surface. Nitration can only be detected by ESCA . This further illustrates the advantages to be gained by the application of ESCA to heterogeneous reactions, like the nitration of cellulose, where the surface and bulk reactions can be very different.

REFERENCES

- 1 F.D. Miles, 'Cellulose Nitrate', Interscience, Boyd, London 1953.
- 2 T. Urbanski, 'The Chemistry and Technology of Explosives', Volume II, Pergamon Press, London 1984.
- 3 A. Hantzsch according to J.G. Hogget, R.B. Moodie, J.R. Penton and K. Schofield in 'Nitration and Aromatic Reactivity', Cambridge University Press, 1971.
- 4 E.G. Cox, G.A. Jeffrey and M.R. Truiler, Nature, 1948, 162, 259.
- 5 G.A. Olah, J. Chem. Soc., 1956, 4257.
- 6 G.A. Olah, S.H. Flood, S.J. Kuhn and J.C. Evans, J. Am. Chem. Soc. 1962, 84, 3687.
- 7 G.A. Olah, S.H. Flood and S.J. Kuhn, J. Am. Chem. Soc., 1961, 83, 4571.
- 8 G.A. Olah, S.H. Flood and S.J. Kuhn, J. Am. Chem. Soc., 1961, 83, 4581.
- 9 G.A. Olah, J.C. Evans, S.H. Flood and S.J. Kuhn., J. Am. Chem. Soc., 1963, 84, 3684.
- 10 J.W. Green in 'Methods in Carbohydrate Chemistry', Vol III, Ed. R. Whistler, Academic Press, London 1953.
- 11 J.G. Hogget, R.B. Moodie, J.R. Penton and K. Schofield in 'Nitration and Aromatic Reactivity', Cambridge University Press, 1971.
- 12 According to J.G. Hogget, R.B. Moodie, J.R. Penton and K. Schofield in 'Nitration and Aromatic Reactivity', Cambridge University Press, 1971.
- 13 E.D. Hughes, C.K. Ingold and R.I. Reed, J. Chem. Soc., 1950, 2400.

CHAPTER SIX - A STUDY OF SURFACE AND BULK NITRATION
IN NITRIC ACID AND IN DICHLOROMETHANE / NITRIC ACID
MIXES

6.1 Introduction.

The use of nitric acid and nitric acid-water mixes to nitrate cellulose is reviewed in Chapter 1. Previous studies of nitration have been limited to determining the extent and rate of nitration in the cellulose bulk and therefore the nature of the nitrating species and the mechanism controlling DOS in nitric acid mixes have remained subject to considerable controversy.^{1,2}

Nitration in nitric acid (alone) or nitric acid-water mixes produces very brittle or shredded cellulose nitrates (depending on water concentration); further, materials of low DOS can not be prepared in these mixes.³ The addition of an 'inert' miscible organic liquid to nitric acid facilitates the production of cellulose nitrates over the complete range of substitution, i.e. $\text{DOS}=0 \rightarrow 3$, without any appreciable destruction of the original cellulose fibre structure. The use of nitric acid-organic liquids to produce very high DOS materials has been widely reported.^{2,4-6} Organic-nitric acid mixes are widely employed to nitrate aromatic compounds; the mechanism of nitration in these mixes has been extensively studied.³ However, in cellulose chemistry the nitration mechanism has received scant attention, most authors glibly citing molecular nitric acid as the nitrating agent.

Soild state ^{13}C nmr has been employed to investigate the substitution distribution of nitrate groups in cellulose nitrates prepared from organic-nitric

acid mixes.²⁴ The substitution distributions reported with bulk DOS are different to those previously reported for nitration in mixed acids. Solution state ¹³C nmr has been employed to further probe the substitution distribution in cellulose nitrates prepared from dichloromethane-nitric acid mixes.

In this chapter the nitration of cellulose in different composition nitric acid-water and organic-nitric acid mixes has been investigated at the surface and in the bulk of the fibre by ESCA, ¹³C nmr and X-ray diffraction. The rates of nitration observed at the fibre surface in these mixes are compared to those previously reported for cellulose in mixed acids and important conclusions are drawn about the nature of the nitrating species and the mechanism of nitration.

6.2 Experimental

Whatman cellulose papers were nitrated at 24°C in the various nitrating mixes as described in the following sections. Pre-treatment of the cellulose is outlined in Figure 2.9. Samples nitrated in nitric acid-water mixes were quenched immediately. Samples nitrated in dichloromethane/nitric acid mixes were either quenched immediately in 5 litres of water or washed with dichloromethane in a buchner funnel prior to quenching. The resulting surface and bulk DOS were found not to be affected by the chosen method of quenching.

Commercial fuming nitric acid was obtained from Aldrich Chemical Co. It was > 97% pure containing 2-3% N_2O_4 . Pure anhydrous nitric acid was prepared by vacuum distillation from a KNO_3/H_2SO_4 mix and used immediately.¹⁰ The dichloromethane (May and Baker Ltd.) was redistilled before use.

ESCA spectra were run on Kratos ES200 and ES300 electron spectrometers. Raman spectra were run on a Varian Carey 82 Raman spectrometer using an Argon gas laser (514.5nm, 200mW). Solution State ^{13}C nmr were run on Bruker AC 250 spectrometer. Solid State spectra were obtained on a Bruker CXP 200 using a contact time of 1ms.

6.3 RESULTS AND DISCUSSION.

6.3.1 Nitration with Nitric Acid-Water Mixes

Table 6.1 presents the surface DOS monitored, by ESCA, after 1 seconds nitration in pure anhydrous nitric acid and 90% nitric acid (10% water).

Table 6.1 DOS with Mix Composition.

% HNO ₃	DOS
100	1.7
90	0.2

Because nitration is a heterogeneous reaction, the order and rate of reaction can not be deduced from bulk studies. However, at the fibre surface the initial rate of nitration may be monitored by ESCA. The results in Table 6.1 show that the addition of water to the anhydrous acid reduces the extent of surface nitration achieved after 1 second by 8 fold. Extending the nitration time (>30 seconds) in the two mixes produced materials of a similar surface DOS (>2).

The presence of the nitronium ion in anhydrous nitric acid is well established.³ The formation of the nitronium ion (autoionization of nitric acid) occurs in two stages:-

Equation 1

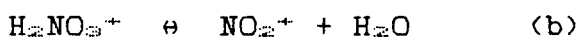
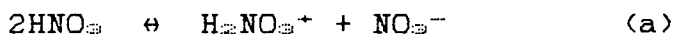

It is not unreasonable to assume that the nitronium ion is responsible for the rapid nitration observed in the pure nitric acid. Reduction in the concentration of

the nitronium ion is reflected by the dramatic change in DOS observed, after 1 second's nitration, in the aqueous (90%) nitric acid. The anti-catalytic effect, of added water, on the rate of reaction in anhydrous nitric acid has been previously reported; the addition of 5% water in the nitration of nitrobenzene reduces the rate by 6 fold.''

6.3.2 The Nitrating Species in Fuming Nitric Acid.

The surface nitration of cellulose papers in fuming nitric acid-water mixes has been investigated as a function of immersion time; the results are presented in Figure 6.1. From this figure it can be seen that the addition of water to fuming nitric acid dramatically reduces the DOS achieved after a 1 second nitration. Nitration of the surface, in the anhydrous nitric acid, is almost complete after 1 second's immersion; in the 80% nitric acid-20% water mix the DOS achieved after a 1 second nitration is negligible.

Employing the greater sampling depth of TiK α x-rays it was found that nitration with anhydrous nitric acid was vertically homogeneous to a depth of > 100Å in less than 5 seconds. This result establishes that it is the rate of nitration that is being monitored, by ESCA, and not the diffusion of the acid into the fibre surface.

The Raman spectrum of fuming nitric acid is presented in Figure 6.2; from this figure it can be seen that the nitronium ion is beyond spectroscopic detectability.

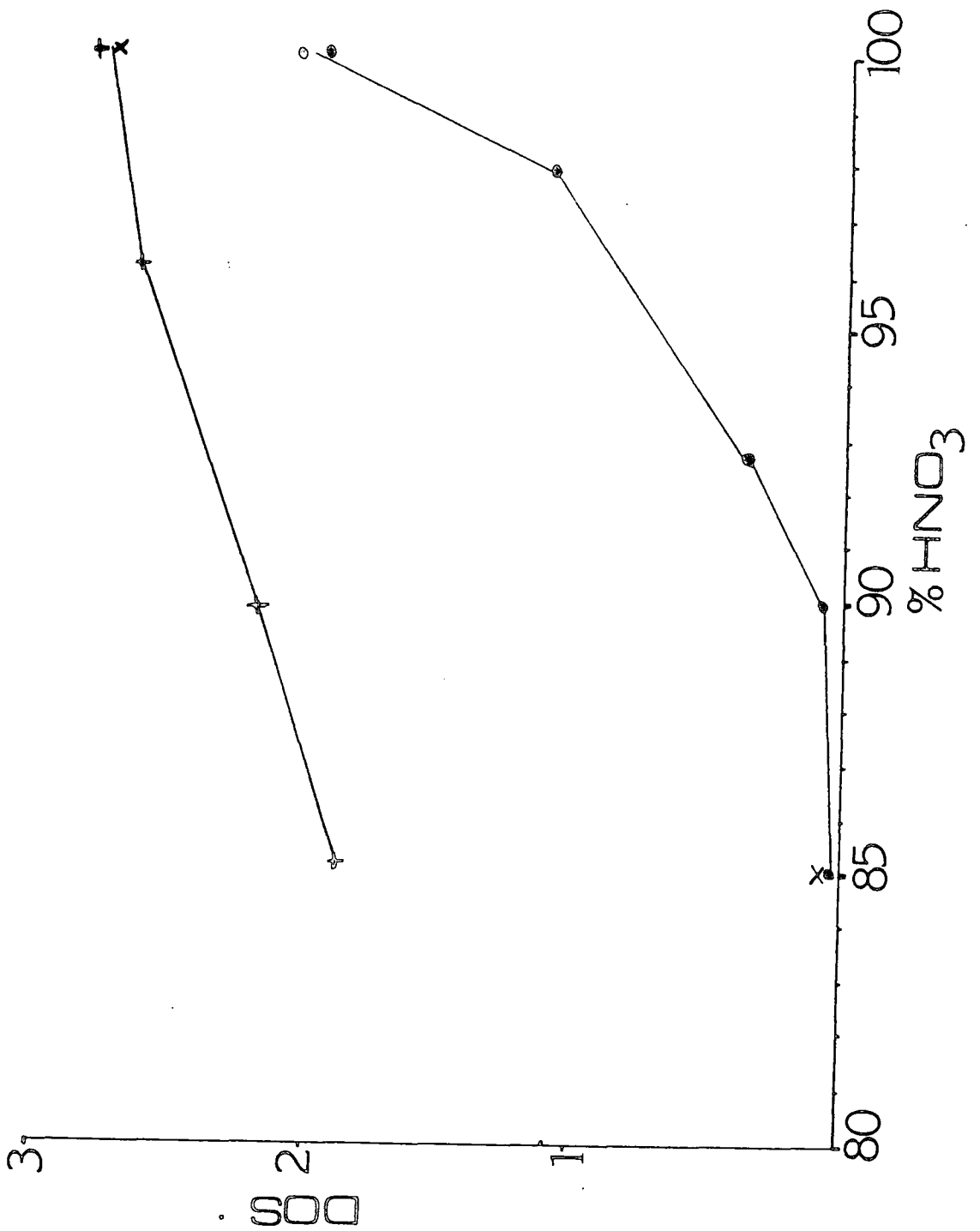

° = 1 second

X = 30 seconds

+ = 30 minutes

Figure 6.1 Surface DOS as a function of immersion time for cellulose papers in nitric acid-water mixes

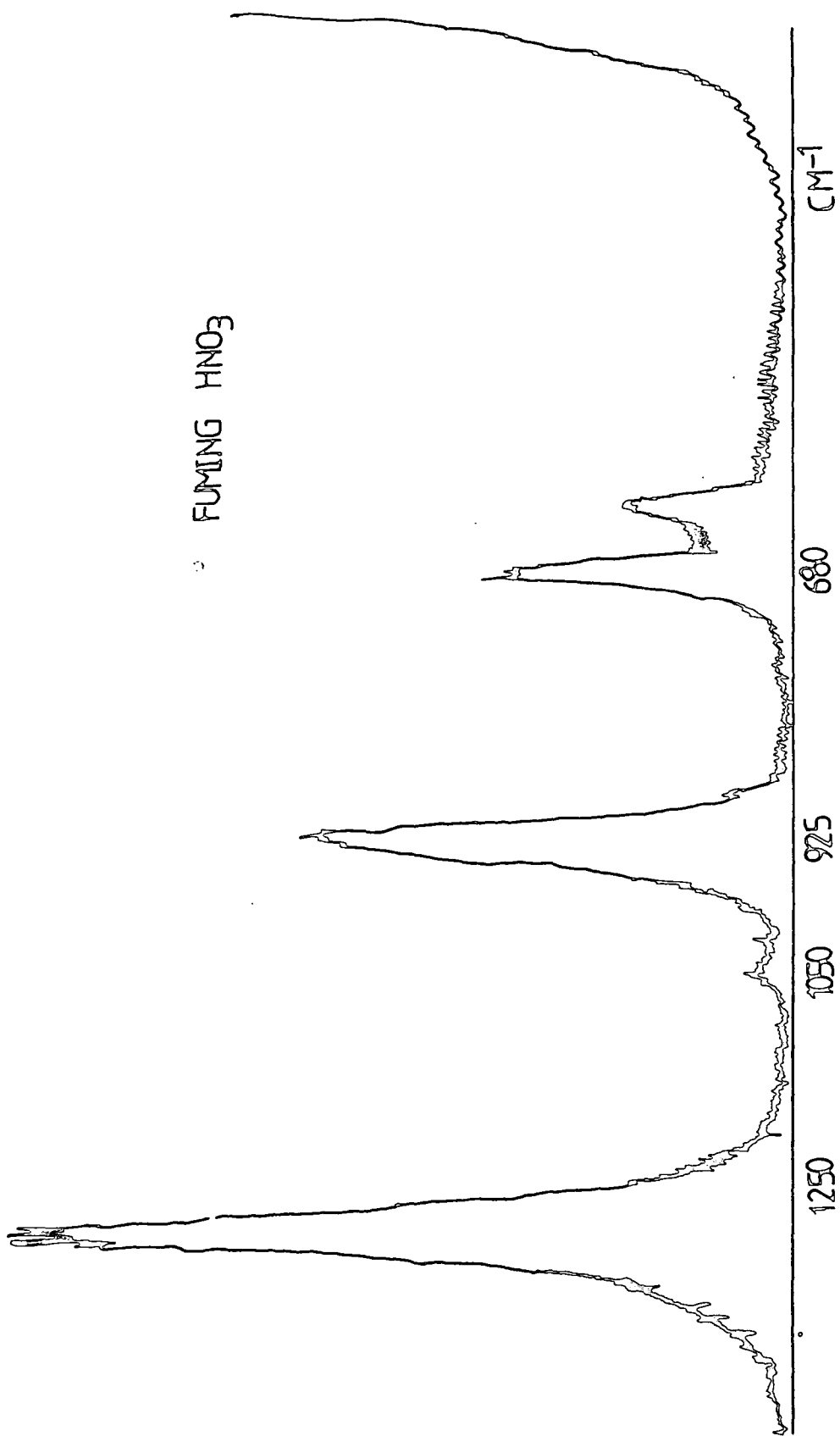

Figure 6.2 Raman Spectrum of fuming nitric acid.

However, in fuming nitric acid it is thought that the nitronium ion is responsible for nitration. This hypothesis can be tested by monitoring the effect that the addition of potassium nitrate has on the rate of nitration in the 100% acid. From Equation 1 it is expected that the addition of the nitrate ions to nitric acid will suppress the formation of the nitronium ion. In Table 6.2 the rates of surface nitration in fuming nitric acid and fuming nitric acid/potassium nitrate mixes, as monitored by ESCA, are compared. It is the initial rate of nitration that is of particular interest; as the nitration reaction proceeds water will be produced which will reduce the rate of reaction.

Table 6.2 DOS achieved with nitration time in fuming nitric acid and fuming nitric acid - potassium nitrate mixes.

<u>Immersion Time</u> <u>/seconds</u>	<u>DOS</u>	
	<u>HNO₃</u>	<u>HNO₃/KNO₃</u>
1	1.86	0.77
5	2.26	1.62
30	2.40	2.20

The data in Table 6.2 shows that the addition of potassium nitrate to nitric acid reduces the level of surface nitration observed (t= 1 and 5 seconds). The DOS of the top 100Å was also monitored by Ti_{Kα} x-rays; nitration was found to be vertically homogeneous at all immersion times and therefore it can be concluded that the addition of nitrate ions reduces the rate of

nitration (and not the diffusion of the acid) in the surface region.

The potential effect of the small N_2O_4 concentration in fuming nitric acid on the nitration reaction is considered to be negligible. This conclusion is based on several observations. Firstly, the surface and bulk DOS achieved by nitration in mixes where nitric acid is replaced by fuming nitric acid remains unaffected. Secondly, the rate of nitration observed in the surface region in fuming nitric acid is the same as that monitored in pure nitric acid. Finally, from the $N_{1.0}$ core level it is evident that only nitration has taken place in fuming nitric acid mixes. However, in DMF, N_2O_4 can nitrite cellulose, but in aqueous media the nitrite ester formed is readily decomposed by hydrolysis.¹²

6.3.3 The Nitrating Species in Aqueous Nitric Acid.

In mixes of > 5% water content nitration still takes place and moderately high equilibrium DOS are still achieved in the surface. It is pertinent to ask what is the nitrating species in these mixes since the nitronium ion is no longer spectroscopically observable (in nitric acid and fuming nitric acid) and electrochemical data suggests it is no longer present at such dilutions (nitric acid).¹¹ However, it has been shown by kinetic studies that in aqueous nitric acid, containing as much as 60 mol.% water, the nitronium ion is still an effective nitrating agent.¹¹ It is possible that molecular nitric acid is responsible for nitration of

cellulose in aqueous mixes; but, it is not inconceivable that the nitronium ion is still responsible for nitration. Miles' has pointed out that cellulose linters preferentially absorb nitric acid from nitric acid-water mixes and therefore in the vicinity of the cellulose hydroxyls the true concentration of nitric acid may be very much higher than expected from the composition of the nitrating liquid. On the basis of the work presented above it is not possible to establish the nature of the nitrating species in aqueous nitric acid. However, in all the other nitrating systems, so far investigated, it has been shown that the nitronium ion is responsible for nitration.

The final DOS achieved by nitrating cellulose with nitric acid is of interest. The surface and bulk DOS of cellulose nitrates prepared from mixed acids have already been shown to differ. In nitric acid the highest bulk DOS generally reported is 2.8;² a DOS of 3 has been reported by nitrating a 2.7 DOS cellulose nitrate in pure nitric acid.¹⁰ It has been suggested that gelatinization of the fibre prevents complete diffusion of the nitric acid throughout the fibre. From the results presented in Table 6.3 it can be seen that at the surface, where diffusion is not considered a problem, fuming nitric acid will only nitrate cellulose to a DOS of approximately 2.4; further, nitration with anhydrous nitric acid only produces a surface DOS of 2.4.

Cellulose papers were nitrated at room temperature for 1 hour in fuming nitric acid and a bulk DOS of 2.7 was measured. A cellulose nitrate (DOS=2.7, prepared in a mixed acid) was nitrated in fuming nitric acid; in Table 6.3 the bulk DOS monitored is presented with nitration time. No gelatinization of the fibres was observed.

Table 6.3 DOS achieved by nitration in fuming nitric acid

		<u>Hours Nitration</u>		
		0	26	71
Surface	DOS	2.4	-	2.45
Bulk	DOS	2.7	2.65	2.75

The data presented in Table 6.3 indicates that a DOS of 2.75 is the maximum bulk DOS obtainable in fuming nitric acid. A 2.83 bulk DOS material immersed in fuming nitric acid has been shown to denitrate to this value¹⁴ and therefore it appears that 2.75 is the equilibrium DOS for cellulose papers in fuming nitric acid.

Because a surface DOS of 3 is not achieved by nitration in fuming nitric acid it is reasonable to assume that DOS is equilibrium controlled. The nitronium ion is believed to be responsible for nitration and from the data, presently available, it is considered that nitric acid must be responsible for denitration. In mixed acids it has been shown that sulphuric acid can denitrate celluloses; esterifications are usually

reversible processes and it is therefore not surprising that a strong acid can cause de-esterification. In concentrated sulphuric acid cryoscopic and spectroscopic evidence indicates that alcohol nitrate esters undergo complex ionization, yielding nitronium ion.¹⁵

The above data suggests that in the bulk of the cellulose fibre the nitration-denitration equilibria are, for some reason, tipped slightly more in favour of nitration. The mechanism of denitration in nitric acid is unclear, however, it is certain that the heterogeneous nature of the nitration reaction influences the final DOS achieved in the cellulose fibre.

6.3.4 Nitration in Nitric Acid-Dichloromethane mixes: The Nitrating Species.

The surface nitration of cellulose papers in a 1:1.5 (mils) fuming nitric acid/dichloromethane mix has been monitored as a function of immersion time; the results are presented in Table 6.4. From the table it can be seen that nitration, in the surface region, is slow compared to nitration in technical acid mixes.

Table 6.4 Surface DOS with Nitration Time in a 1.5:1 mil Dichloromethane/Nitric Acid Mix.

Time	Surface DOS
1s	0.20
10s	0.60
30s	1.60
60s	2.14
>6000s	2.35

This mix was examined by Raman spectroscopy, the nitronium ion band at 1398 cm^{-1} could not be detected. The state of pure nitric acid in chlorinated solvents has been investigated; the mixes are characterized by poor electrical conductivity and the nitronium ion is not spectroscopically detectable.¹⁶ However, although the nitronium ion can not be detected by physical methods, kinetic studies have provided compelling evidence for the formation and effectiveness of this species in the nitration of aromatic compounds.²⁰

The addition of KNO_3 to dichloromethane / nitric acid mixes was found to reduce the surface DOS in the initial stages of nitration by α 25%. The effect of adding KNO_3 to these mixes is similar to that reported previously for the addition of KNO_3 to nitric acid. It, therefore, seems reasonable to assume that the nitronium ion is the important nitrating species of cellulose in dichloromethane/nitric acid mixes. The concentration of the nitronium ion in these mixes is low and this is reflected by slow rate of nitration monitored at the cellulose surface.

In mixed acids it is thought that the rate of nitration in the bulk is diffusion controlled. This hypothesis can be tested by comparing the speed at which the bulk nitration of cellulose papers proceeds in different acid mixes.

From surface studies it is known that nitration in an anhydrous mixed acid is extremely rapid, above it has been shown that at the surface nitration in dichloromethane/fuming nitric acid mixes is not. In Tables 6.5 and 6.6 the bulk DOS achieved in these two acid systems at various nitration times are presented.

The data presented in Table 6.5 clearly indicates that the rate of bulk nitration observed in mixed acids is diffusion controlled. However, in dichloromethane/fuming nitric acid mixes this is not the case. From Tables 6.4 and 6.6 it can be seen that the rates of nitration, surface and bulk, in dichloromethane /fuming nitric acid mixes, are comparable.

Table 6.5 Bulk DOS with Nitration Time: Mixed Acids*.

<u>T (minutes)</u>	<u>DOS</u>
2 minutes	0.54
11 minutes	1.10
21 minutes	1.50
41 minutes	1.90 ⁺
120 minutes	2.70

* 75% H_2SO_4 , 22.5% HNO_3 , 2.5% H_2O +24°C

+ Unusually wide variation in DOS noted.

Table 6.6 Bulk DOS with Nitration Time: Dichloromethane/
f. Nitric Acid*.

<u>T (minutes)</u>	<u>DOS</u>
10 minutes	2.53
35 minutes	2.66
60 minutes	2.74
180 minutes	2.73
2400 minutes	2.63

* 1.5:1 (mils) mix at +24°C

6.3.5 Surface and Bulk DOS with Mix Composition.

The surface and bulk DOS achieved by nitrating 1 gram of cellulose papers in various nitric acid/dichloromethane mixes have been investigated; the results of which are presented in Figure 6.3. The total volume of the nitrating mix was kept at 80 mils and the nitric acid:dichloromethane ratio varied.

However, before considering the figure in detail it is appropriate first to comment on the validity of the surface DOS values presented. The potential effect of hydrocarbon contamination at the cellulose surface on the DOS has been considered in Chapter 2. It has been assumed that contamination exists as a patched overlayer on the fibre surface or in the fibre surface and that low

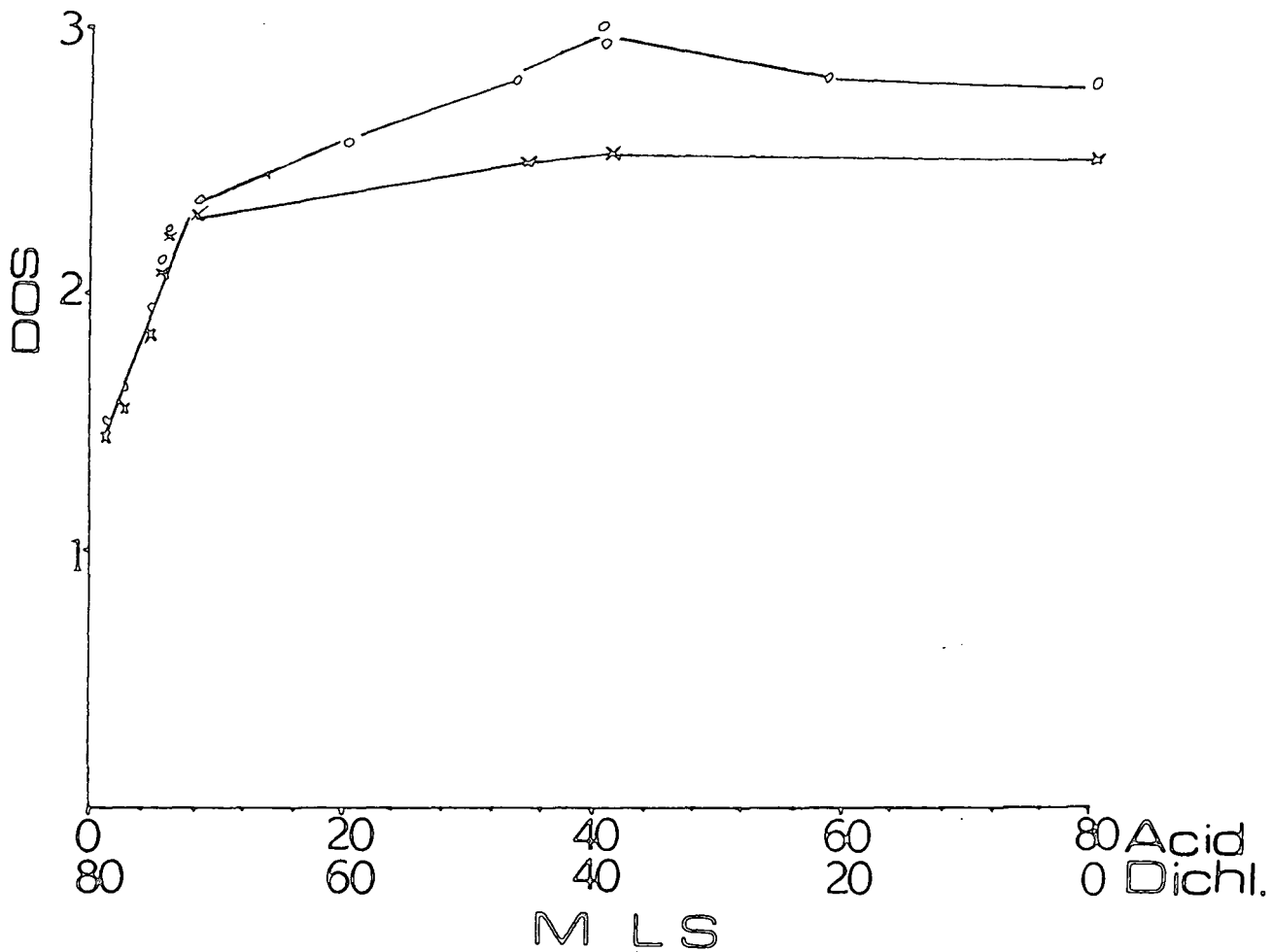

x= surface DOS

o= bulk DOS

Figure 6.3 Surface and bulk DOS with mix composition.

levels of contamination do not effect the DOS monitored. However, the cellulose nitrates of DOS > 2 prepared in dichloromethane/fuming nitric acid mixes, after stabilization, exhibited higher than usual levels of contamination (ca.25% of the C_{100} envelope); prior to stabilization the cellulose surfaces were not seriously contaminated. The surface DOS of the stabilized materials were significantly lower than nitrates which were washed in tap water only.

In Chapter 2 it was shown that unreacted nitric acid adheres to the surface of celluloses prior to stabilization; with stabilization the nitrogen level monitored at the surface drops with the removal of this acid. It is uncertain in cellulose nitrates prepared from dichloromethane/fuming nitric acid mixes whether the surface DOS drops with stabilization due to (a) removal of unreacted nitric acid or (b) because of the increasing hydrocarbon contamination.

From Figure 6.3 it can be seen that the surface and bulk DOS reached in the cellulose fibres increases with increasing nitric acid concentration until the 40:40 ml situation is reached. Surface and bulk DOS do not appear comparable at high DOS; this may be the result of surface contamination. However, two pieces of data argue against this interpretation:-

(1) the surface and bulk DOS in cellulose nitrates prepared from fuming nitric acid are different,

(ii) in materials of lower DOS, surface and bulk are comparable and the level of hydrocarbon contamination in these materials is ca.20% of the C_{1s} envelope.

Clearly the processes that have produced the curves in Figure 6.3 are complex. It might be initially supposed that at low nitric acid concentration nitration is limited by an insufficient mass of acid to fully nitrate 1 gram of cellulose. However, this explanation is easily dismissed by simple calculation of the number of moles of acid to the number of moles of cellulose ($\times 3$), which reveals there is a considerable excess of nitric acid in all the mixes employed.

From the ESCA data it is evident that nitration is reversible. If nitration were not, then no correlation between surface and bulk DOS would be observed. Nitration would proceed from the fibre surface inwards and the surface DOS monitored by ESCA would be very high, while in the bulk of the fibre the DOS would be very low. However, surface and bulk DOS are in close agreement and therefore it is clear that the final DOS established is equilibrium controlled. The nitrating species is the nitronium ion and it is thought that the predominant denitrating agent is the hydrated nitric acid molecule, water being produced in the nitration reaction. Since surface and bulk DOS are comparable it is clear that the 'accessibility' of the crystalline and amorphous regions to this species must be equal.

As the concentration of nitric acid increases then the effect of hydrated nitric acid on the DOS is

expected to diminish. For example, nitrating in a 40:40 mil mix and assuming complete reaction (i.e DOS=3) the ratio of unreacted nitric acid to hydrated nitric acid will be one hundred and sixty to one in the used acid mix. It is expected that this 'used' acid mix will be able to nitrate fresh cellulose to a very high DOS. This hypothesis is tested later.

In the 40:40 mil mix both surface and bulk DOS are at a maximum. Clearly the nitration reaction is at a maximum and the denitration reaction(s) are at a minimum. In light of the above discussions, it is not certain that surface and bulk DOS are in fact different.

Although a cellulose nitrate with a DOS of 3 can not be prepared in fuming nitric acid it can be seen, from Figure 6.3, that the addition of dichloromethane to fuming nitric acid facilitates near complete nitration. It is perhaps possible to explain this observation in terms of the 'polarity' of the nitrating mix and its ability to support charged species. The addition of dichloromethane to nitric acid will reduce the 'polarity' of the nitrating mix and therefore its ability to stabilize charged species. If denitration proceeds via protonation of the nitrate ester and then ionization, to give the nitronium ion, then as the 'polarity' of the nitrating mix decreases this mechanism will become less favourable. This argument is, to a certain extent, supported by data already presented, namely that by physical measurements (spectroscopic and electrochemical)

the presence of nitronium ion, or any charged species, can not be detected in these mixes.¹⁶

The use of a 40:40 mil dichloromethane-nitric acid mix (i.e. where fuming nitric acid is replaced by pure nitric acid) to nitrate cellulose has been investigated. A bulk DOS of 2.94 and a surface DOS of 2.2 were recorded, however, a high level of extraneous hydrocarbon contamination was observed in the C₁₀ envelope. It is not possible to determine whether this contamination has depressed the DOS monitored.

6.3.6 The Re-use of a Dichloromethane-Nitric Acid Mix.

A 40:40 mil mix has been re-used to nitrate fresh 1 gram samples of cellulose and the resulting surface and bulk DOS were monitored as a function of the number of nitrations. The relevant data is presented in Figure 6.4. Although the cellulose batches were well squeezed to remove any adhering acid, which was returned to the mix, the mix was only employed six times as some acid was lost on quenching of each nitration. From the curves in Figure 6.4 it is clear that the water produced, as a consequence of nitration, only has a slight effect on the DOS achieved. From the figure two other important observations can be made. Firstly, at high DOS the surface and bulk DOS are not in close agreement; secondly, with continued re-use the agreement in surface and bulk DOS improves. These results support the conclusions that are drawn from Figure 6.3.

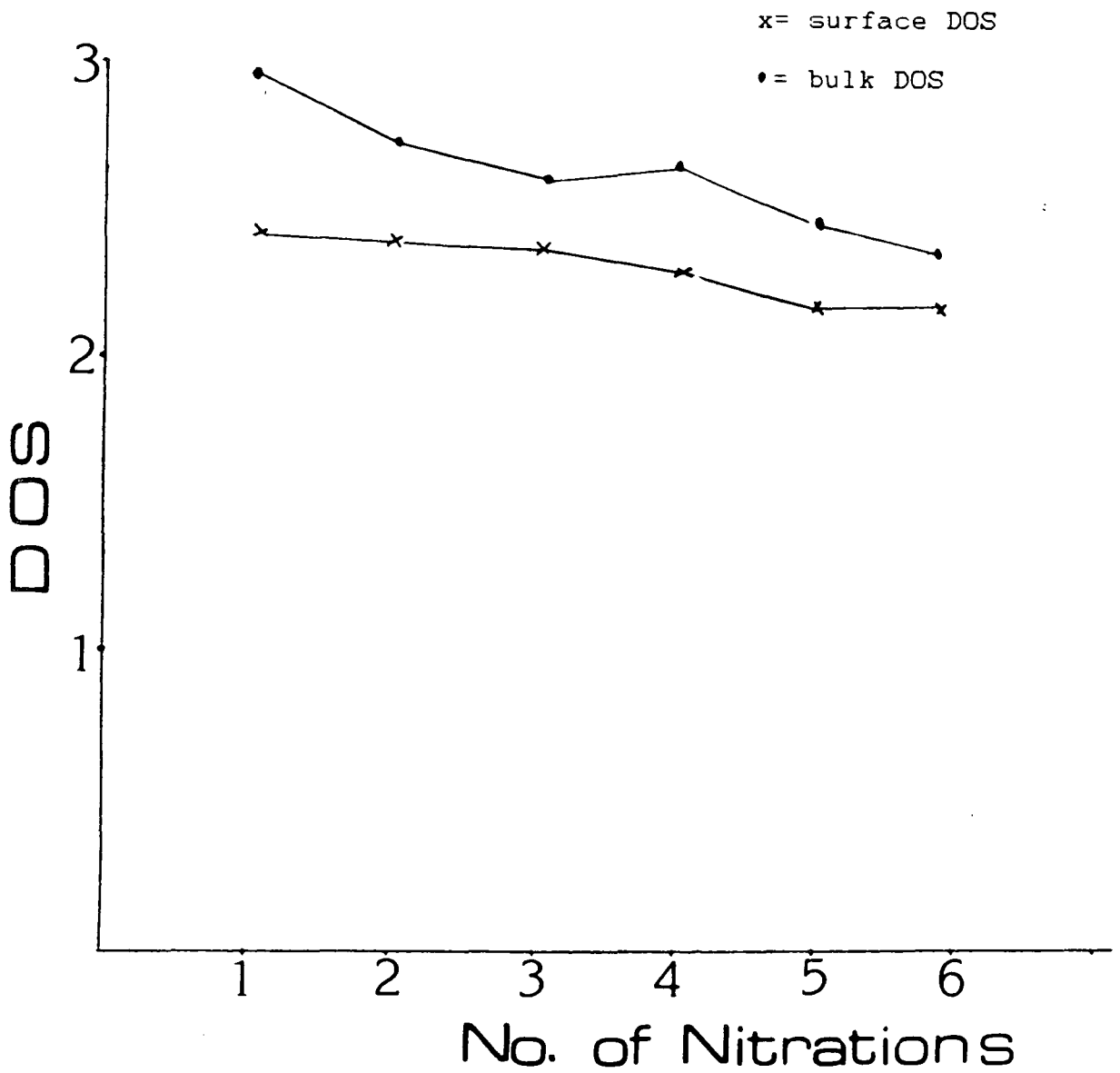

Figure 6.4 Surface and bulk DOS with successive nitrations in a 40:40 ml. mix.

6.3.7 A ^{13}C nmr and X-ray diffraction study of the bulk chemistry of dichloromethane-nitric acid prepared cellulose nitrates.

The solution state ^{13}C nmr spectra for a series of cellulose nitrates prepared from fuming nitric acid / dichloromethane mixes, at room temperature, have been run, see Figures 6.5-6.9. The DOS of the materials run were in the range of 1.85-2.95. Peak assignments can be made on the basis of those reported in Section 4.3.5.

Clark et al¹⁷ have previously reported the use of ^{13}C nmr, solution state, to determine the substitution distribution and sequence distribution of nitrate groups in cellulose nitrates prepared from mixed acids. Hence, the substitution distribution of materials prepared from dichloromethane/ fuming nitric acid mixes and sulphuric/nitric acid mixes can be compared.

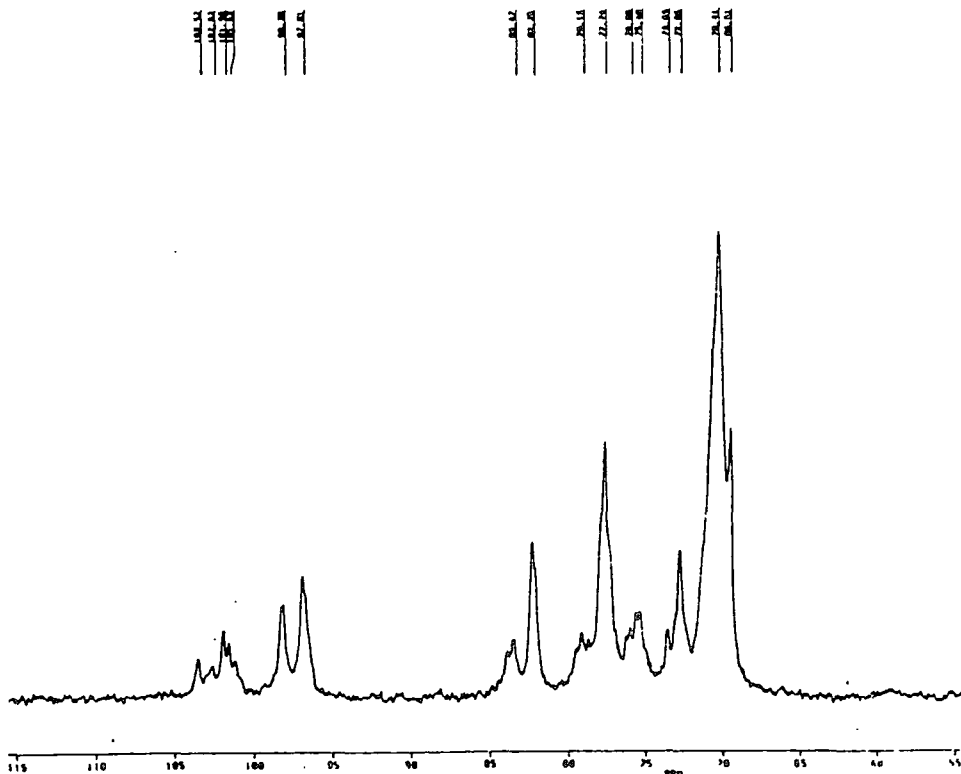

Figure 6.5 ^{13}C nmr spectrum of a 1.85 DOS material.



Figure 6.6 ^{13}C nmr spectrum of a 2.1 DOS material.

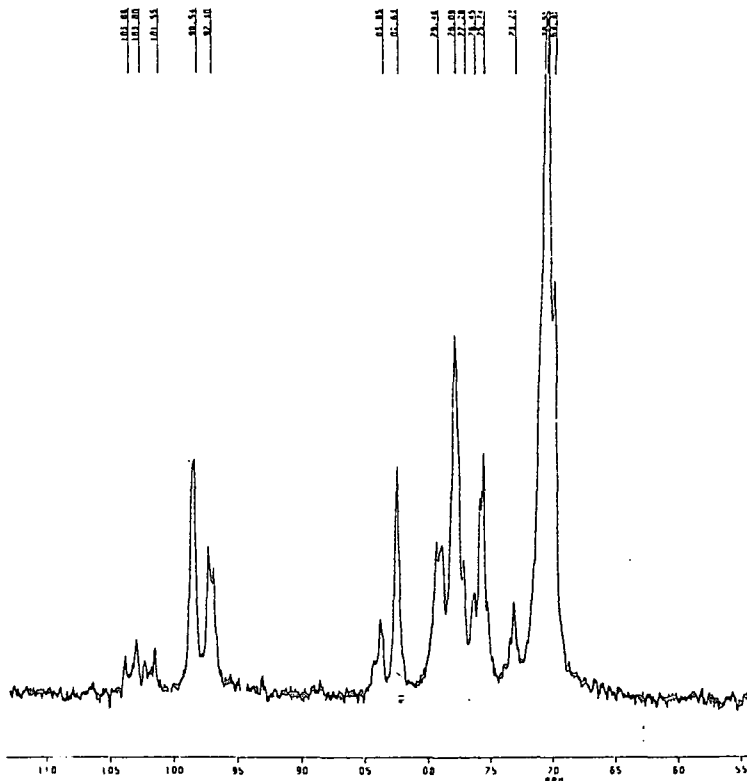

Figure 6.7 ^{13}C nmr spectrum of a 2.38 DOS material

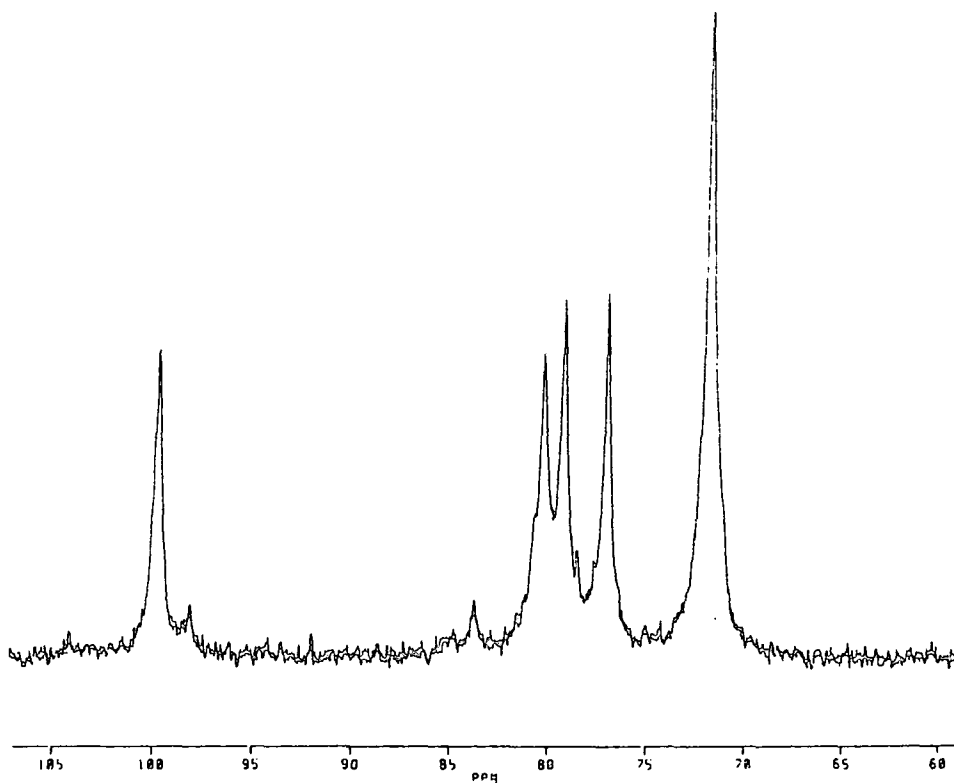

Figure 6.8 ^{13}C nmr spectrum of a 2.7 DOS material

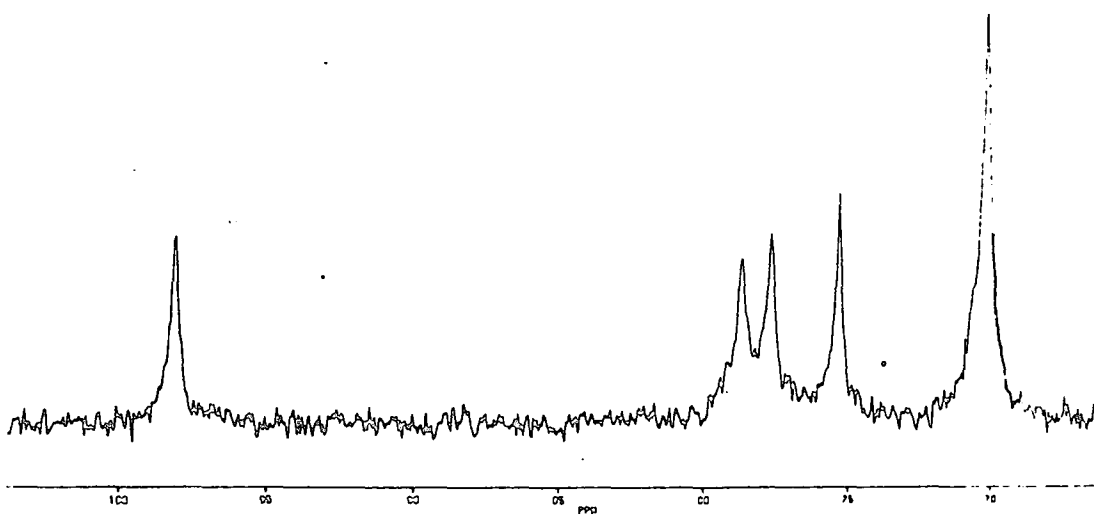

Figure 6.9 ^{13}C nmr spectrum of a DOS=2.95 material.

In Table 6.4 the substitution distribution of two such materials, DOS 2.15, are compared.

Table 6.4 Comparison of the substitution distribution in typical cellulose nitrates (DOS=2.1) prepared under different conditions.

	<u>Method of production.</u>	
	<u>Sulphuric/Nitric</u>	<u>Dichloromethane/Nitric</u>
Trisub.	48%	32%
2,6 Disub.	18%	39%
3,6 Disub.	10%	16%
6-mono	6%	13%
Unsub.	17%	0%
DOS by ^{13}C nmr	2.1	2.15

From Table 6.4 it can be seen that the substitution patterns in the two materials are very different. From visual comparison of the spectra presented in Figures 6.5-6.9 with those of cellulose nitrate prepared from mixed acids, e.g. see Figure 4.11, the most obvious difference in the spectra is evident at 60 ppm. In mixed acids the disappearance of unsubstituted rings are not reported until a bulk DOS of 2.6 is reached. In dichloromethane-fuming nitric acid mixes all unsubstituted residues have disappeared by a DOS of 2.1.

Koenig et al²⁸ have employed solid state ^{13}C nmr to follow the nitration of cellulose linters in nitric acid-dichloromethane mixes. From the disappearance of the C_6 resonances at 66 and 64 ppm they report that the all residues are substituted by a DOS of 1.4.

However, this result must be

treated with caution for although the quality of spectra obtainable for polymers from solid state nmr has much improved in recent years, the S/N ratio achieved is still poor.

The solution and solid ^{13}C nmr spectra of a 2.35 DOS cellulose nitrate, prepared in a mixed acid, were run, see Figures 6.10 and 6.11. From the solid state spectrum it appears that there are no longer any unsubstituted residues in the material. However, from the solution state spectrum it is evident that a small proportion of rings remain unsubstituted. In Figure 6.12 the ^{13}C nmr solid state spectrum is presented of a 2.4 DOS cellulose nitrate prepared from a dichloromethane-fuming nitric acid mix; again only from the solution state spectra, Figure 6.7, can it be determined, with confidence, whether any rings remain unsubstituted. Figure 6.13 shows the solid state ^{13}C nmr spectrum of a 1.5 DOS cellulose nitrate prepared from a dichloromethane/fuming nitric acid mix. It is uncertain from this spectrum whether any unsubstituted residues exist in this material. Unfortunately there are no suitable solvents for cellulose nitrates of this DOS. However, from the solution state ^{13}C nmr spectra of a 1.85 DOS material, Figure 6.5, it can be seen from the peak at 60ppm that a small proportion of residues are unsubstituted.

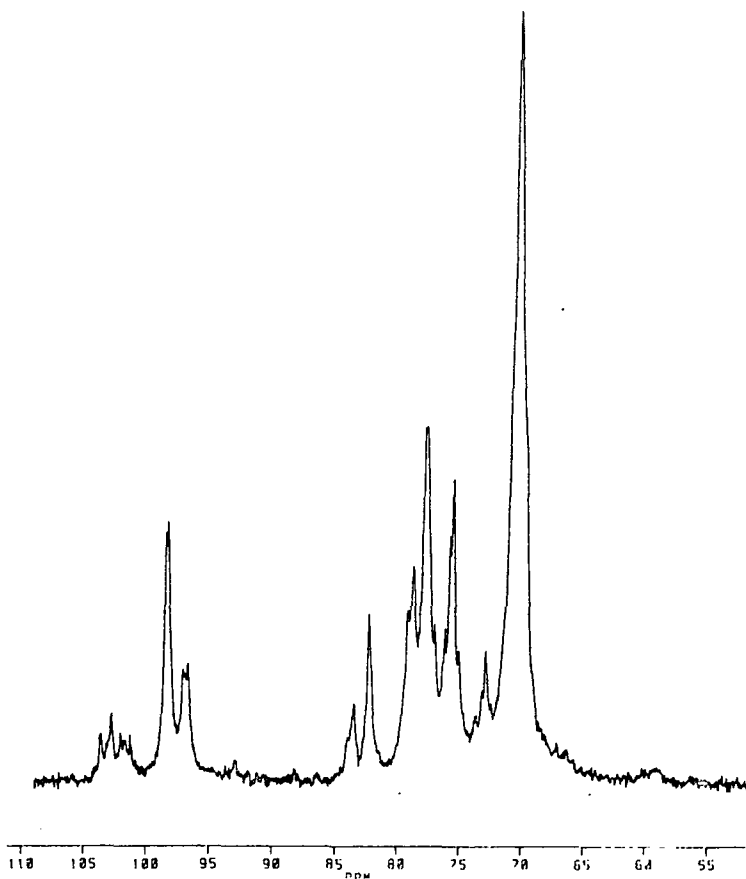

Figure 6.10 Solution state ^{13}C nmr spectrum of a 2.35 DOS cellulose nitrate

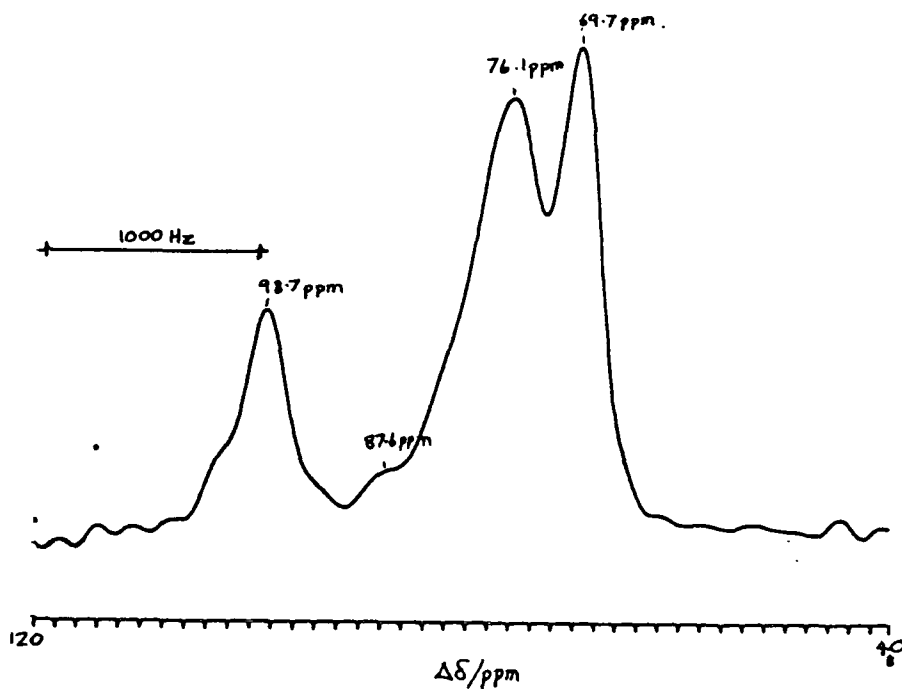

Figure 6.11 The CP/MAS solid state ^{13}C spectrum of a 2.35 DOS cellulose nitrate.

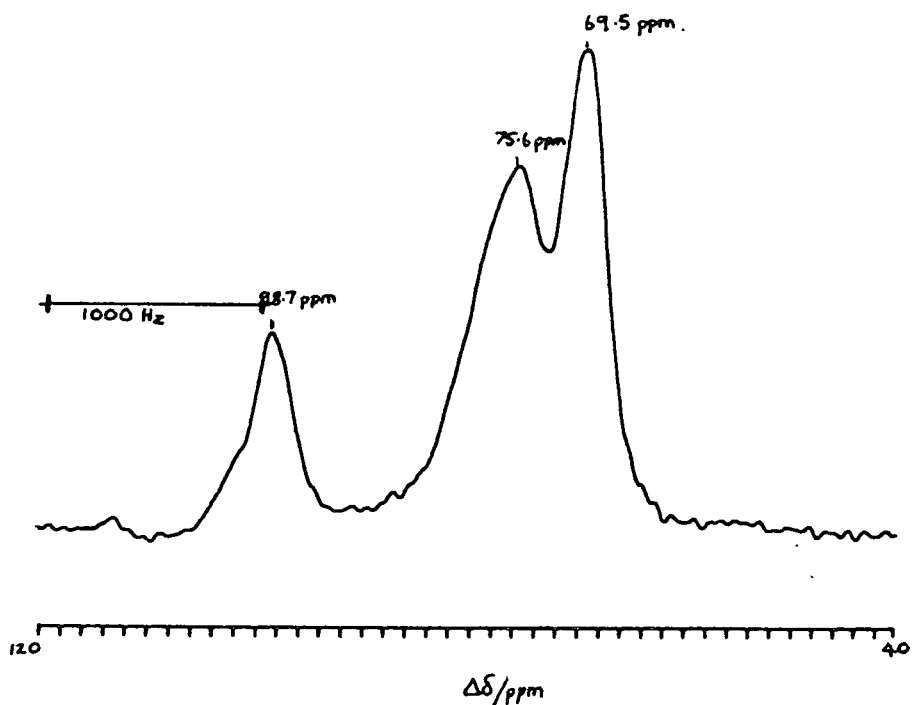

Figure 6.12 The CP/MAS spectrum of a 2.4 DOS cellulose nitrate.

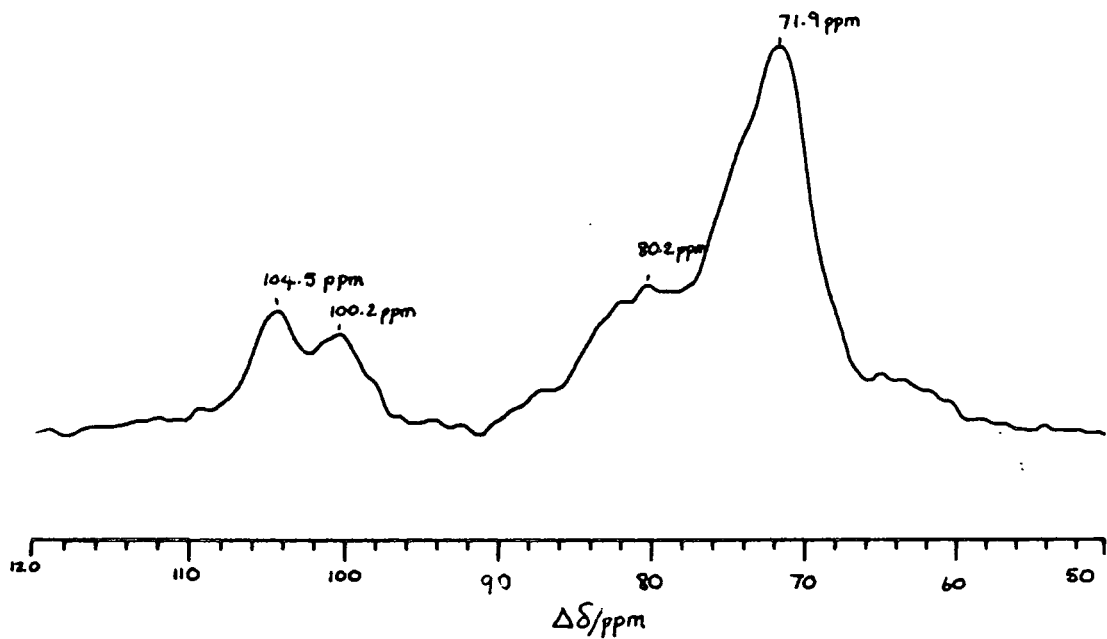

Figure 6.13 The CP/MAS spectrum of a 1.5 DOS cellulose nitrate.

From Table 6.4 it is evident that other major differences in substitution pattern exist. In the cellulose nitrate prepared from mixed acids there is a much greater proportion of trisubstituted residues, but a much lower proportion of disubstituted and mono substituted residues.

A similar analysis was carried out for 2 materials of DOS 1.9, the results are presented in Table 6.5.

Table 6.5 Comparison of the substitution distribution in typical cellulose nitrates (DOS=1.9) prepared under different conditions.

	<u>Method of production.</u>	
	<u>Sulphuric/Nitric</u>	<u>Dichloromethane/Nitric</u>
Trisub.	36.0%	23.0%
2,6 Disub.	22.5%	38.5%
3,6 Disub.	15.5%	19.0%
6-mono	9.5%	15.5%
Unsub.	16.5%	4.0%

From Table 6.5 it can be seen that the substitution distribution patterns of the two cellulose nitrates are very different. As observed in the 2.1 DOS materials there is a much higher proportion of trisubstituted and unsubstituted residues in the mixed acid prepared cellulose nitrate.

Materials of DOS > 2.4 were analysed. Irrespective of the method of production employed, at

equivalent DOS the substitution distribution patterns were found to be the same.

Summarizing, cellulose nitrates prepared from dichloromethane/fuming nitric acid mixes and from technical mixed acids display very different substitution patterns at lower DOS and this must reflect differences in the rate constants for reaction at the C₂, C₃ and C₆ sites. In the dichloromethane/fuming nitric acid prepared materials there are no unsubstituted residues in a 2.1 DOS material. From the absence of the C₆ resonances in the solid state spectra (66 and 64ppm) it appears possible that all residues are at least monosubstituted by a DOS of 1.5. However, the solution state ¹³C nmr spectra of a 1.85 DOS cellulose nitrate does not support this view. In cellulose nitrates prepared from technical mixed acids, unsubstituted residues are present at much higher DOS (2.6).

The mean interchain d(101) spacing in cellulose nitrates reflects the distribution of nitrate groups both around a single residue and along the chain (sequence distribution). The d(101) spacings in dichloromethane-fuming nitric acid prepared materials have been determined. In Figure 6.14 these spacings are compared to those reported for cellulose nitrates prepared from mixed acids. The dichloromethane prepared materials, in general, have lower mean interchain d(101) spacings. It is only in the higher DOS materials that the mean interchain spacings are comparable.

The difference in $d(101)$ spacings is perhaps to be expected. As discussed, from the nmr data it is evident that there are important differences in the substitution distribution patterns of these materials. At equivalent DOS ($\ll 2.4$) there is a greater proportion of trisubstituted residues in the sulphuric/nitric acid prepared materials. Further, the disappearance of unsubstituted residues in dichloromethane/fuming nitric acid prepared materials occurs at much lower DOS than in sulphuric/nitric acid prepared materials. It does not seem unreasonable to assume that these differences in substitution pattern are responsible for the differences $d(101)$ spacing observed between the sulphuric-nitric acid and dichloromethane/nitric acid prepared materials.

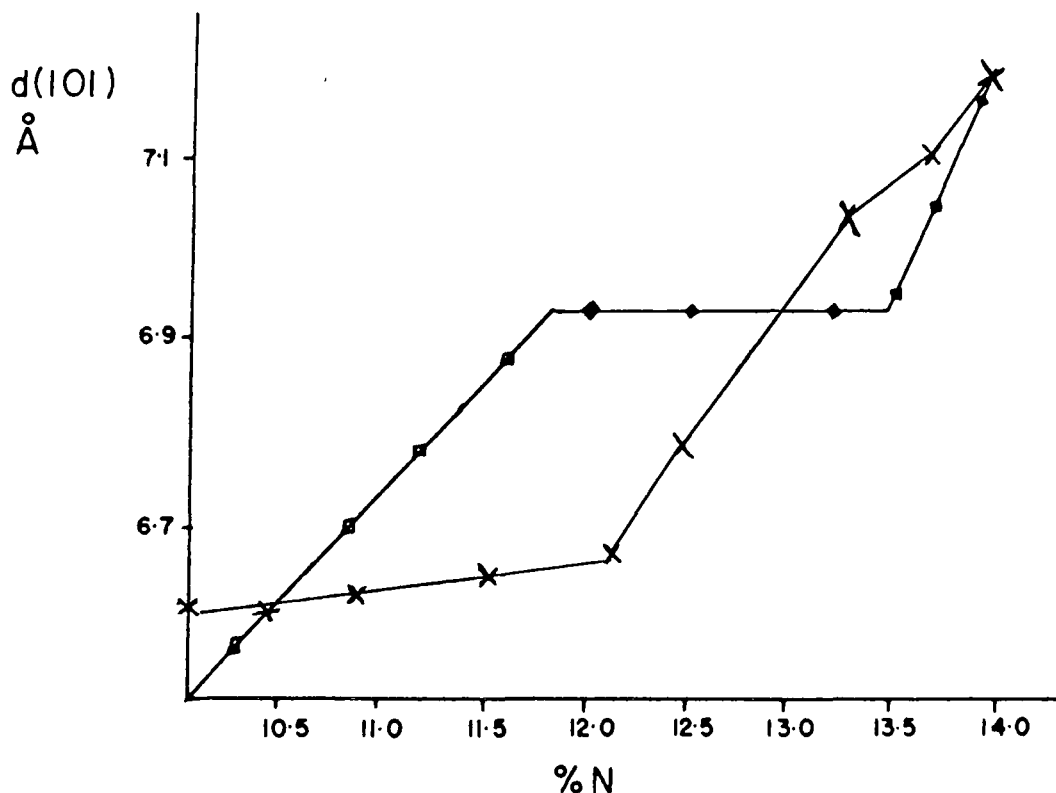

x=Dichloromethane/nitric acid prepared materials.

•=Sulphuric/nitric acid prepared materials.

Figure 6.14 Mean interchange $d(101)$ spacing with DOS

6.3.8 A Study of Thermal and X-ray Stability.

It is generally thought that cellulose nitrates prepared in mixes free from sulphuric acid are more thermally stable. Thermal instability is characterized by nitrogen loss on heating in air or vacuum. Weight loss in a sample on heating can be followed by thermogravimetric analysis.

The stability of two 2.7 DOS cellulose nitrates are compared, Figures 6.15 and 6.16. The material in Figure 6.15 was prepared in a mixed acid; the material in Figure 6.16 was prepared from a dichloromethane/nitric acid mix. Both materials were stabilized by boiling prior to analysis. From the figures it can be seen that the materials display markedly different thermal stability. The small weight loss observed in the materials on heating up to 135°C is due to the loss of water. The continued and dramatic weight loss in Figure 6.15 is due to the evolution of nitrogen from the sample.¹⁸

The reduced thermal stability of the material in Figure 6.15 is attributed to the presence of sulphate esters and sulphuric acid in the material which can not be removed by boiling. The presence of sulphur in the surface of this material is confirmed by ESCA.

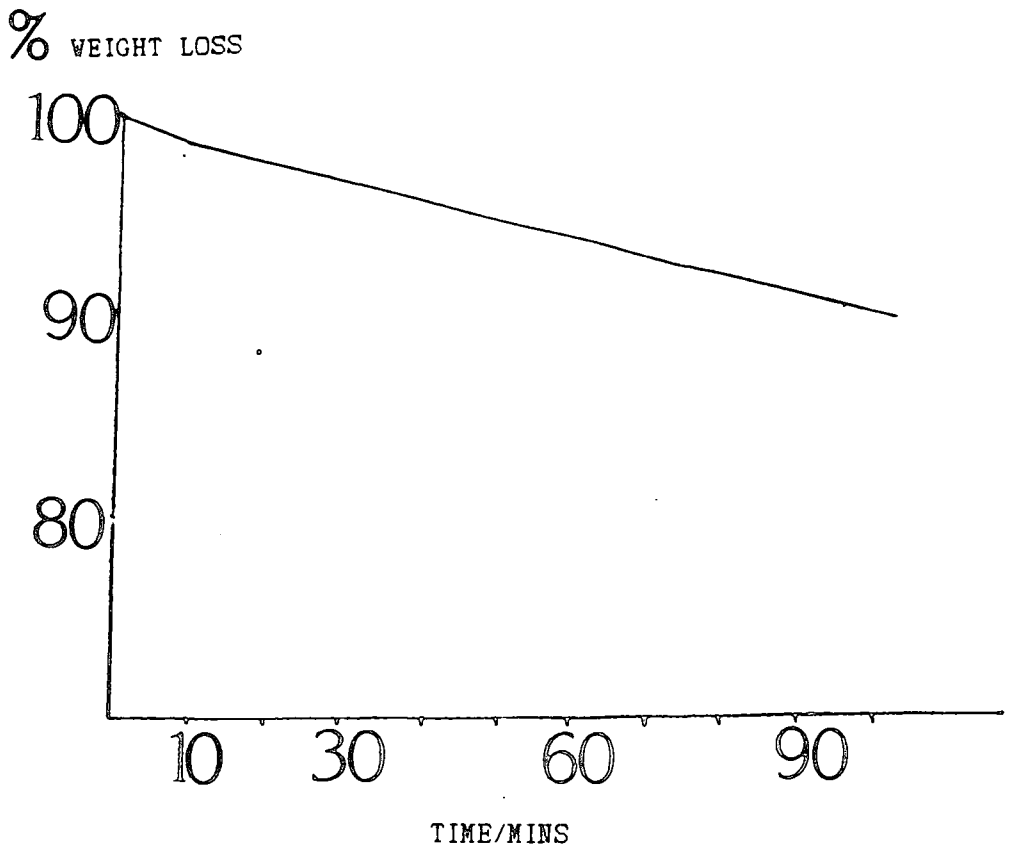

Figure 6.15 T.g.a. of 2.7 DOS mixed acid prepared cellulose nitrate.

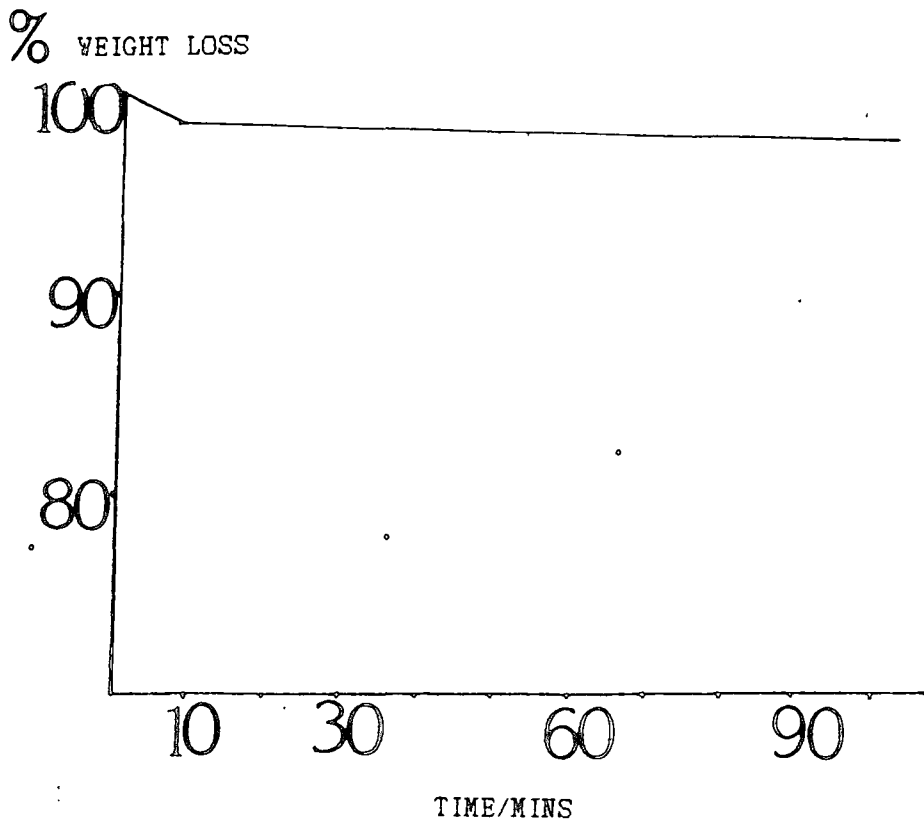

Figure 6.16 T.g.a. of 2.7 DOS dichloromethane/nitric acid prepared cellulose nitrate.

Fowler^{1,2} has shown that the effects of thermal degradation are limited to the bulk of the fibre. In contrast the effects of electromagnetic degradation can be monitored at the fibre surface. The degradation reactions of cellulose nitrates on exposure to Mg_{Kα} and Ti_{Kα} x-rays have been well reviewed in the literature.^{1,2} A Barton type reaction has been proposed to describe the formation of the degradation products.² The Barton Reaction is catalysed by H₂SO₄, H₃PO₄ and P₂O₅. Hence it has been suggested that sulphate and phosphate esters act in a catalytic or photosensitising role in the degradation of cellulose nitrates on exposure to Mg_{Kα} or Ti_{Kα} x-rays. This hypothesis can be tested by comparing the x-ray degradation of nitrates prepared from mixed acids and dichloromethane/fuming nitric acid mixes under the same x-ray source.

The x-ray degradation of the two cellulose nitrates were monitored on the ES 300 by exposing them to Mg_{Kα} x-rays (96 Watts). From the N_{1s} core levels the main reaction observed was photo-reduction of the nitrate ester. The changes observed in both the N_{1s} and C_{1s} core levels were the same as those reported in Chapter 2.

In Figure 6.17 the changes in the C_{1s} and N_{1s} core level with exposure time are displayed in the form of block histograms. From this figure it can be appreciated that the rate of degradation in the materials is comparable. This result indicates that sulphuric acid does not play a catalytic or photosensitising role in the x-ray degradation of cellulose nitrates.

PREPARATION.

DICHLORO/NITRIC ACID SULPHURIC/NITRIC ACID.

Exposure
Time
Minutes

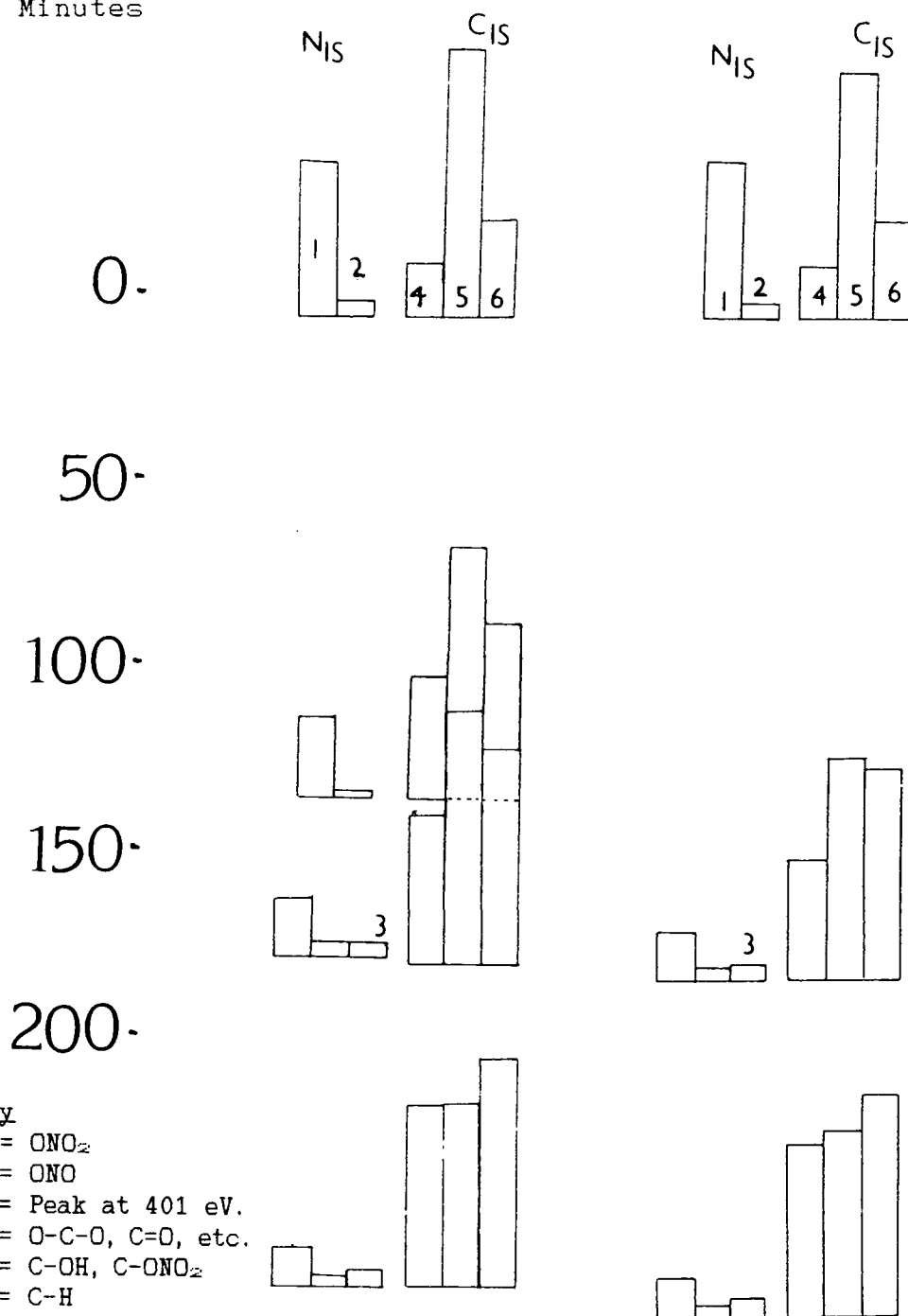

Figure 6.17 Changes in the components in the N_{1s} and C_{1s} core levels of two cellulose nitrates with exposure time to Mg_{Kα} x-rays.

Summarizing, it is clear that sulphuric acid/sulphate esters catalysis the thermal degradation of cellulose nitrates, but do not affect the stability of these materials to electromagnetic radiation.

6.3.9 Summary.

In this chapter the surface and bulk nitration of cellulose papers in nitric acid and dichloromethane / nitric acid mixes has been investigated and materials prepared in the latter mixes were examined by ^{13}C nmr and x-ray diffraction.

The data presented in this chapter strongly indicates that the nitronium ion is the important nitrating species in both nitric acid and nitric acid / dichloromethane mixes. In dichloromethane / nitric acid mixes it appears, from the surface and bulk DOS monitored, that nitration is homogeneous throughout the cellulose fibres at lower DOS (< 2.4) and that the DOS achieved by nitrating in these mixes is equilibrium controlled. At high DOS, surface and bulk DOS do not appear to be the same. In nitric acid, from the surface DOS monitored (2.45), it is evident that the DOS achieved by the nitration of cellulose fibres in the pure acid is equilibrium controlled and not limited by the accessibility of the hydroxyls to the nitrating mix, as previously reported.

The $d(101)$ spacings and substitution distributions of cellulose nitrates prepared from dichloromethane / nitric acid mixes, are at lower DOS very different to those reported in materials prepared from mixed acids.

6.3.10 An Overall Summary of the Nitration Reaction of Cellulose in Various Nitrating Media with special reference to the Role of Accessibility and Equilibria in Controlling DOS.

The work contained in this thesis has been directed towards developing a better understanding of the mechanism and control of nitration in cellulose materials. Molecular nitric acid has, even in recent reviews, been cited as the effective nitrating species for cellulose, while in nearly all other fields of organic nitrations the nitronium ion is accepted as the nitrating species. A plausible explanation for this divergence in thought is perhaps historical. Ingold's major work on nitration mechanism was published in the mid and late 1950's, whilst the major work on cellulose nitration was carried out in the 1930's. Miles' comprehensive review of cellulose nitrate chemistry was published in 1955 and does not refer to the work of Ingold. Although Miles acknowledges the presence of the nitronium ion in mixed acids, he cites the nitric acid molecule as the active species in all nitrations of cellulose. Since Miles' review there has been little interest, until very recently, in the nitration mechanism. The most recent reviews of cellulose nitration (Stephenson, 1981 and Urbanski, 1984) reference the work of Miles and draw similar conclusions on the nature of the nitrating mechanism, identifying nitric acid as the nitrating species.

Ingold and others established the nitronium ion as the important nitrating agent in aromatic nitrations on the basis of kinetic studies of nitration in mixes of

mixed acids. This is not surprising in view of the above discussion, i.e. the uneven nature of the nitration in materials prepared from mixed acids versus the uniform nature of the nitration in the materials prepared from nitric acid - dichloromethane mixes.

The control of DOS in cellulose nitration has previously been explained in terms of both equilibria and accessibility. It is hoped that the work presented in this thesis helps to resolve the existing conflict between the accessibility and equilibrium arguments.

REFERENCES

- 1 F.D. Miles, 'Cellulose Nitrate', Interscience, London 1953.
- 2 T. Urbanski, 'Chemistry and Technology of Explosives', Vol. 4, Pergamon Press, London, 1984.
- 3 F.D. Miles and M. Milbourn, J. Phys. Chem., 1930, 34, 2598.
- 4 Z.A. Rogovin and P. Paradnia according to D. Jones in 'Cellulose and its Dervs.', Eds. N.S. Bikales and L. Segal, Publ. Interscience, 1972.
- 5 A. Bouchonnet, Mem Poudres, 1938, 28, 295.
- 6 H. Yamaoka and T. Shiha, Makromol. Chim., 1966, 99, 117
- 7 H. Yamaoka and T. Shiha, J. Polym. Sci. B, 1966, 5, 629
- 8 J. Koeing, P. Patterson et al, J. Polym. Sc. Polym. Phys. Ed., 1985, 2348.
- 9 J.G. Hoggett, R.B. Moodie, J.R. Penton and K. Schofield, 'Nitration and aromatic reactivity', Cambridge Uni. Press., 1971.
- 10 Private Communication, Dr. A. Cooney, RARDE, Waltham Abbey.
- 11 According to J.G. Hoggett, R.B. Moodie, J.R. Penton and K. Schofield in 'Nitration and aromatic reactivity', Cambridge Uni. Press., 1971.
- 12 D.C. Johnson in 'Cellulose Chemistry and its Applications', Eds. T.P. Nevell and S.H. Zeronian, Publ. Ellis-Horwood, Chichester, 1984.
- 13 J. Trommel, Comm. N.V. Koninkl. Ned. Springstaffenfabrieken Amsterdam, No. 13.
- 14 P.J. Stephenson, Ph.D. Thesis, 1981, Uni. of Durham.
- 15 R.G. Coombes in 'Comprehensive Organic Chemistry' Eds. D. Barton and W.D. Ollis, Pergamon Press, Oxford, 1979.
- 16 I.M. Kolthoff and A. Willman, J. Am. Chem. Soc., 1934, 56, 1007.
- 17 D.T. Clark, P.J. Stephenson (a) Polymer, 1982, 23, 1295; (b) with F. Healey, Polymer, 1981, 22, 1112.
- 18 J. Isler and D. Flegier in 'Cellulose and its Dervs.' Eds. J.F. Kennedy, G.O. Phillips, D.J. Wedlock and P.A. Willams, Publ. Ellis Horwood, Chichester, 1985.
- 19 A.H.K. Fowler, H.S. Munro and D.T. Clark in 'Cellulose and its Dervs.' Eds. J.F. Kennedy, G.O. Phillips, D.J.

Wedlock and P.A. Willams, Publ. Ellis Horwood,
Chichester, 1985.

20 A.H.K. Fowler Ph.D. Thesis, 1984, University of
Durham.

CHAPTER SEVEN - A PRELIMINARY INVESTIGATION OF THE
PLASMA ETCHING OF CELLULOSE NITRATE

7.1 Introduction

The potential use of cellulose nitrate as a self-developing resist material in integrated circuit manufacture has recently been reported.¹⁻³ These resists are a class of material which volatilize during exposure, eliminating the need for subsequent development stages. Use of self-developing resists in the microfabrication process is beneficial due to a decrease in fabrication process steps; additionally the depositing, doping and etching process can be combined in situ.³

Cellulose nitrate functions as a self-developing resist when exposed to an argon ion beam (Ar^+) or an argon fluoride laser.¹ However, when exposed to a hydrogen ion beam (H^+) or an argon ion beam at greater than 200°C cellulose nitrate decomposes to form a non-volatile residue.¹ The nature of this residue has been examined by ESCA. From the N_{1s} and O_{1s} and core levels it appears that the residue contains less nitrogen and oxygen than cellulose nitrate.³ From the C_{1s} envelope it is apparent that this residue comprises of a 'graphite like' material.

Plasmas have been used to remove resist materials from the surface of integrated circuits, avoiding the environmental problems and expense usually encountered with chemical and electrochemical methods.⁴ The etch rate of cellulose nitrate in a 3% O_2 -200W plasma has been reported to be a factor of 2.5 slower than that of Si,

indicating that cellulose nitrate may also be suitable as a masking material for silicon.'

From the work presented earlier in this thesis it is clear that important differences exist in materials of the same DOS which have been prepared from different nitrating media. In previous publications on the etching of cellulose nitrate, the method of manufacture of the material has not been reported. The objective of the work presented in this chapter was to study the effect of various plasma treatments on cellulose nitrate as a function of DOS and preparation method. The surfaces of etched materials were examined by ESCA and the etch rate is calculated from the weight loss measured in the materials with exposure time.

7.2 Experimental

Cellulose nitrates were prepared either in mixed acids or nitric acid - dichloromethane mixes at 20°C; cf. chapters 3 and 6.

Plasma etching was carried out in a ES2000 Polaron Plasma Asher/ Etcher; power, pressure and flow rates are reported where necessary.

Materials were weighed on a Cahn Electrobalance. Core level spectra were recorded on an Kratos ES300 electron spectrometer.

Results and Discussion

7.3.1 The Etch Rate of H₂SO₄/HNO₃ prepared Cellulose Nitrates in Oxygen Plasmas.

In Figure 7.1 the % weight loss with time is presented for the etching of a 2.7 DOS cellulose nitrate in a 5 W oxygen plasma. The oxygen flow rate was set at 0.75cm³/minute. The samples employed were in the form of papers. The papers were etched once only, weighed and then discarded. The surface area of the samples was approximately 1 cm²; it was assumed that the area/mass ratio of the papers was constant in the samples etched. The papers were laid flat in the centre of the plasma reactor. From the figure it can be seen that there is a constant % weight loss from the sample with time; this has been calculated to be 0.35% per minute.

In Figure 7.2 the experiment has been repeated at higher power (100 W). There is a constant weight loss with etch time over the first 30 minutes of approximately 2.5%/ minute. However, at longer etch times the % weight loss per minute is much lower; over the next 30 minutes the % weight loss is < 1%/minute. Clearly, with time the material becomes increasingly more difficult to etch. A possible explanation for this observation is presented later.

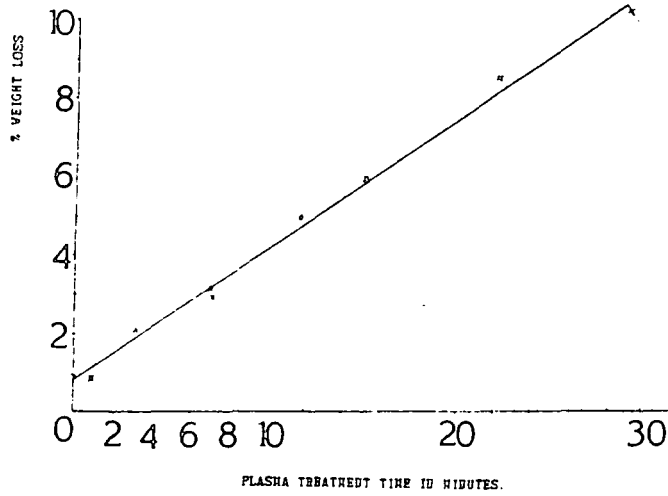

Figure 7.1 Etch rate of a 2.7 DOS cellulose nitrate in a 5 W oxygen plasma.

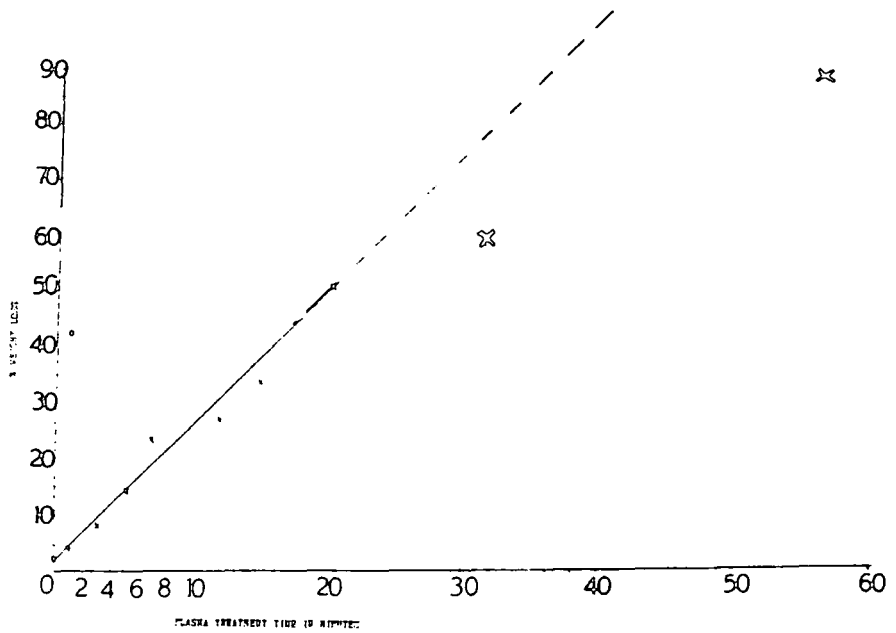

Figure 7.2 Etch rate of a 2.7 DOS cellulose nitrate in a 100 W oxygen plasma.

7.3.2 The Etch Rate of HNO₃/CH₂Cl₂ prepared Cellulose Nitrates in Oxygen Plasmas.

In Figure 7.3 the % weight loss from a 2.7 DOS cellulose nitrate in a 100 W O₂ plasma is presented as a function of etch time. In Chapter 6 it has been shown that the substitution distribution and sequence distribution in these materials are different to those of cellulose nitrates prepared from technical mixed acids, but it is not thought that these differences will affect the etch rate. However, sulphate esters and residual sulphuric acid in a cellulose nitrate catalyse thermal degradation and it was expected that a similar effect in plasmas might be observed. From comparison of Figures 7.2 and 7.3 it can be seen that this is not the case during the early stages of etching. The % weight loss/minute in Figure 7.3 is 2.2.

At longer etch times several materials showed unusually high % weight losses. This weight loss was accompanied by a grey ash residue. It is thought that these materials have combusted rather than etched.

From Figure 7.2 it is apparent that some process at long exposure times is suppressing the etch rate in cellulose nitrates prepared from mixed acids. This process does not take place in cellulose nitrates prepared from dichloromethane/nitric acid mixes. The nature of this process has been identified from surface studies of the etched materials, see Section 7.3.3.

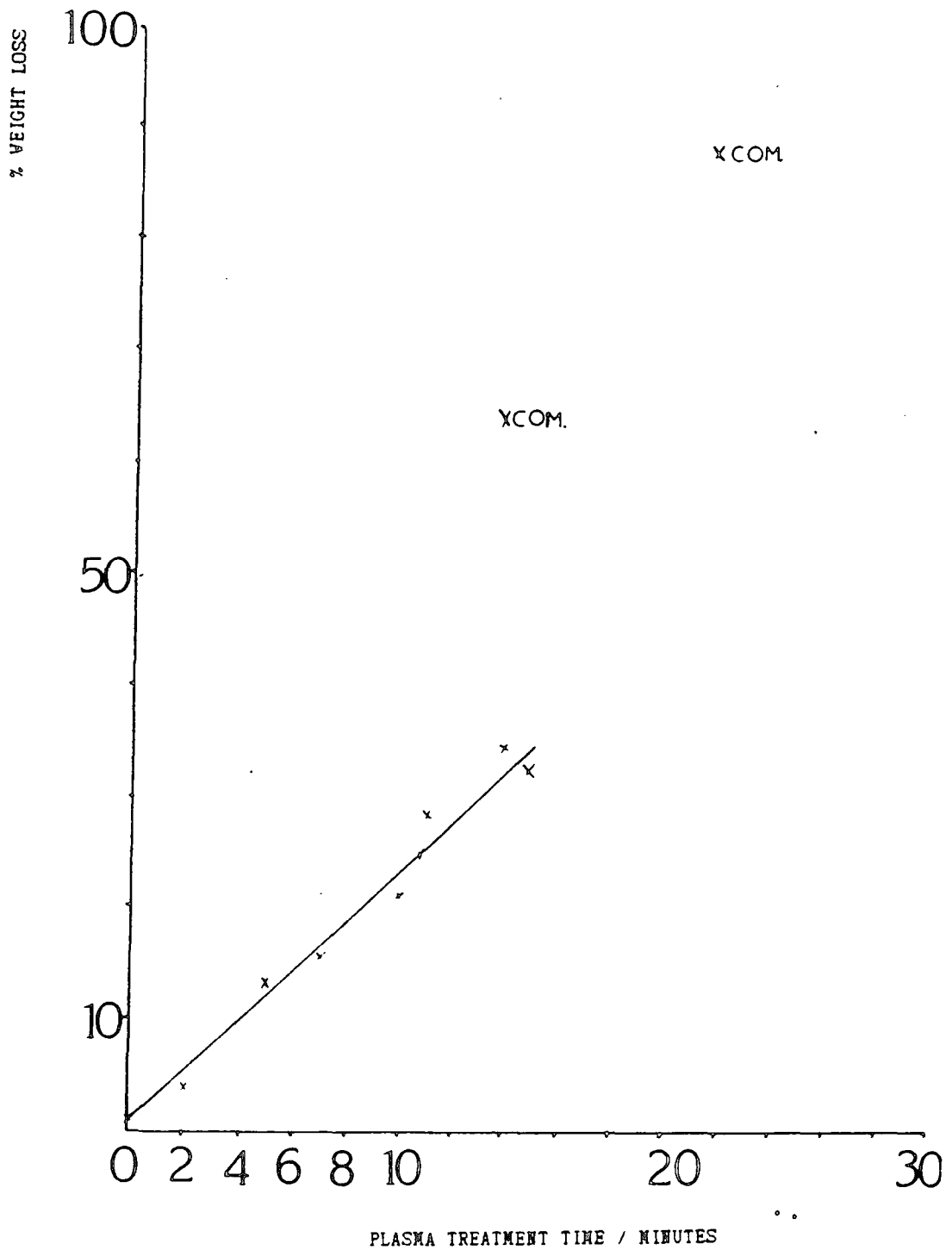

COM = Combusted material.

Figure 7.3 Etch rate of a 2.7 DOS cellulose nitrate (dichloro/nitric acid prepared) in a 100W oxygen plasma.

7.3.3 A Surface Study of Etched Materials.

The potential of ESCA to monitor changes occurring at the surface of material is well established. From Figures 7.2 and 7.3 it can be seen that, at long exposure times, different etch rates are observed for materials of the same DOS. The materials were prepared differently and from the C_{1s} , N_{1s} and S_{2p} core levels of the pristine materials it can be seen that the surface of the materials are in fact different, see Figure 7.4. Changes in the C_{1s} , N_{1s} and S_{2p} core levels have been followed, as a function of etch time, in a sulphuric acid prepared cellulose nitrate. Figure 7.5 shows that in the N_{1s} core level there is a steady conversion of the nitrate ester (408eV) to a new nitrogen functionality which appears at lower binding energy (401 eV). The conversion is not 1 to 1 and the identity of the new functionality is not known. Complete conversion of the nitrate ester is not achieved, presumably because of concomitant ablation.

From the C_{1s} core level it can be seen that there is conversion of the C-ONO₂ functionality to more oxidized functionalities, presumably carbonyl, carboxylate and carboxylic acid functionalities in the plasma.

DICHLORO/NITRIC ACID PREPARED

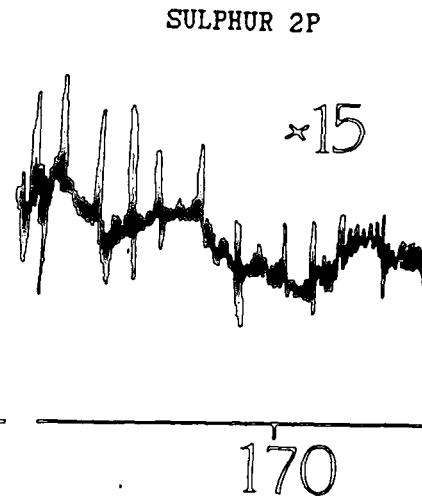
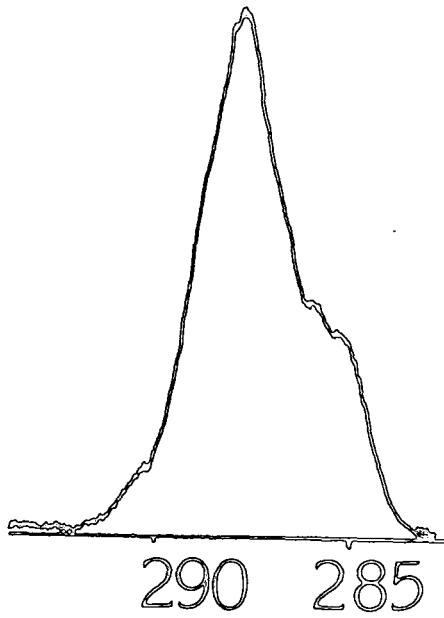
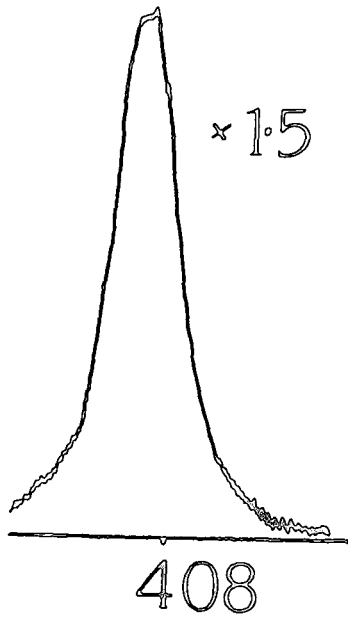

BINDING ENERGY (eV)

SULPHURIC ACID PREPARED

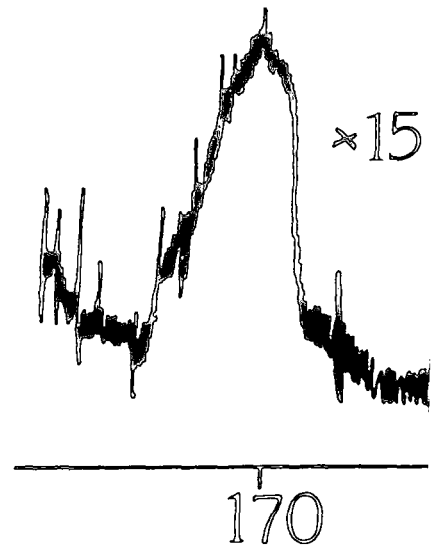
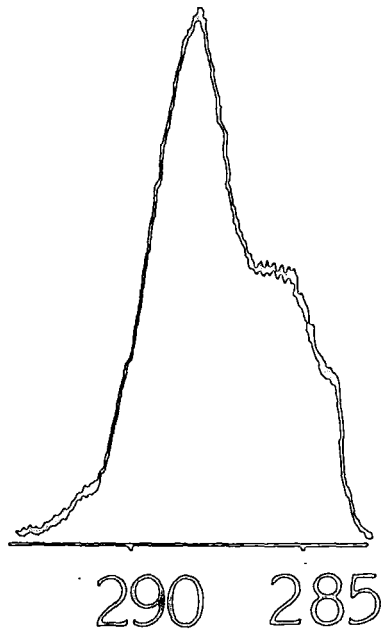
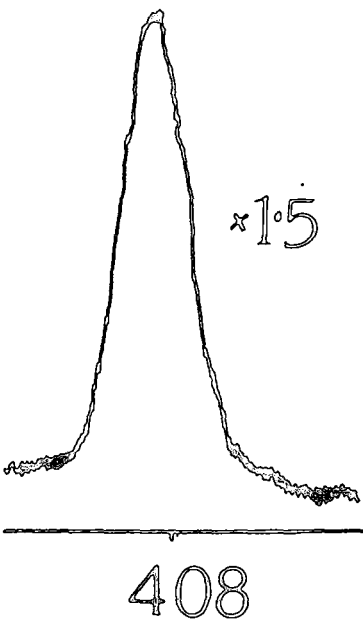

BINDING ENERGY (eV)

Figure 7.4 Core level spectra of a dichloromethane/nitric acid prepared cellulose nitrate and a mixed acid prepared cellulose nitrate.

T/ MINUTES

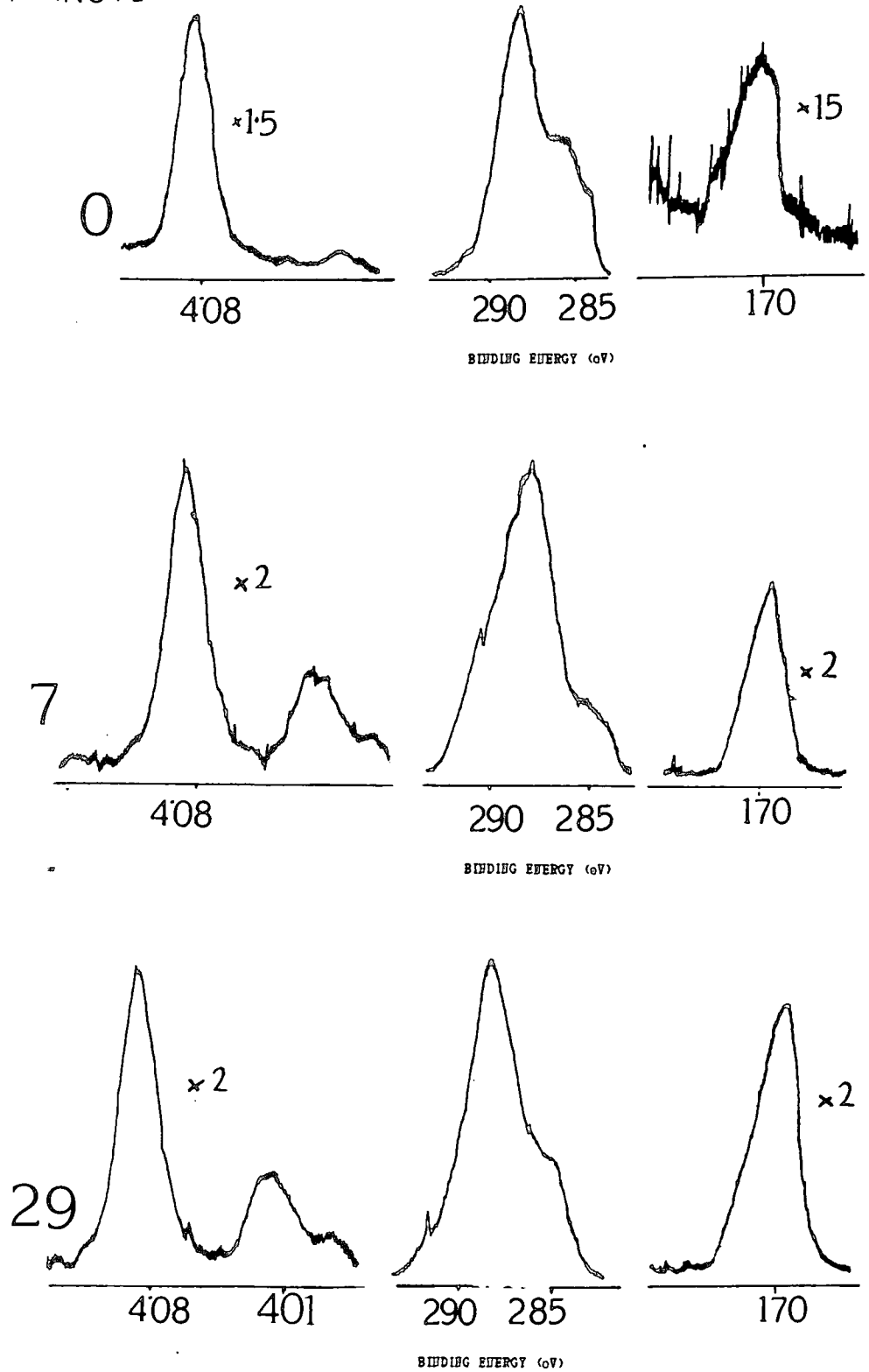

Figure 7.5 Changes in the core level spectra of a mixed acid prepared cellulose nitrate with etch time in a 5 W oxygen plasma.

The changes in the N_{1s} and C_{1s} core levels described are very similar to those observed previously reported in the x-ray and u.v. degradation of cellulose nitrates. From the changes observed in the N_{1s} core level it is evident that photoreduction of the nitrate ester is taking place in the oxygen plasma.

The changes in the observed etch rate, Figure 7.2, can perhaps be rationalized from the changes in the core level spectra, Figure 7.5. From the S_{2p} core level it is evident that there is an increase in the level of residual sulphur on the cellulose surface with etch time. It is envisaged that the sulphur residue does not etch easily and is therefore protecting the cellulose nitrate surface underneath from the plasma and hence the etch rate decreases with increasing sulphur concentration. The high binding energy (170 eV-charge corrected) of the S_{2p} core level peak indicates that the residual sulphur is present in a highly oxidized form.

The results of this preliminary study show that the method of manufacture of the cellulose nitrate chosen might have important consequences on its' suitability as a resist material. In a 100 W/ O_2 plasma, a cellulose nitrates prepared from technical mixed acids become very difficult to etch because of sulphur contamination of the surface, whilst materials prepared from dichloromethane/nitric acid mixes appear to etch at a constant rate.

7.3.4 A Study of the Reactions of Cellulose Nitrate in Argon Plasmas.

A 2.7 DOS cellulose nitrate was treated with a 100 W argon plasma. In Table 7.1 % weight loss is presented with etch time. From the results presented it is clear that no significant etching has taken place.

Changes in the N_{1s} and C_{1s} core levels with exposure are presented as a function of etch time in Figure 7.6. Plasma treatment of the cellulose nitrate has resulted in considerable surface modification. The changes observed in the core levels are very similar to those previously reported for x-ray, u.v. and O_2 plasma irradiation. At very long exposure times there is a near complete conversion of the nitrate groups at the surface to the new nitrogen functionality. From the N_{1s} core level areas it is clear that this conversion is not 1:1, i.e. nitrogen is lost from the sample. This result will perhaps account for the small % weight loss observed in Table 7.1.

Table 7.1 %Weight Loss with Etching Time

<u>Etch Time/minutes</u>	<u>%Weight Loss</u>
1	2
5	0
10	1.5

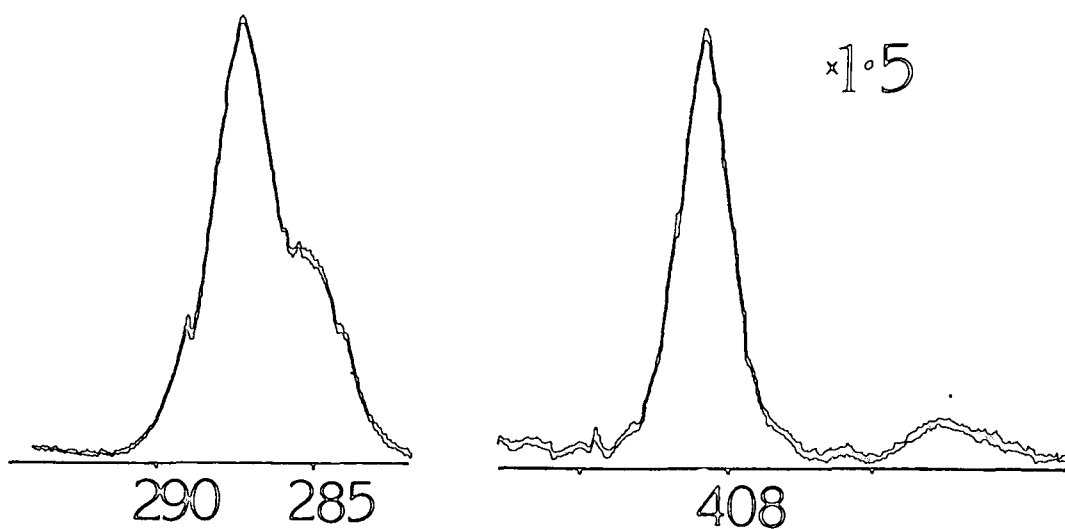

BINDING ENERGY (eV)

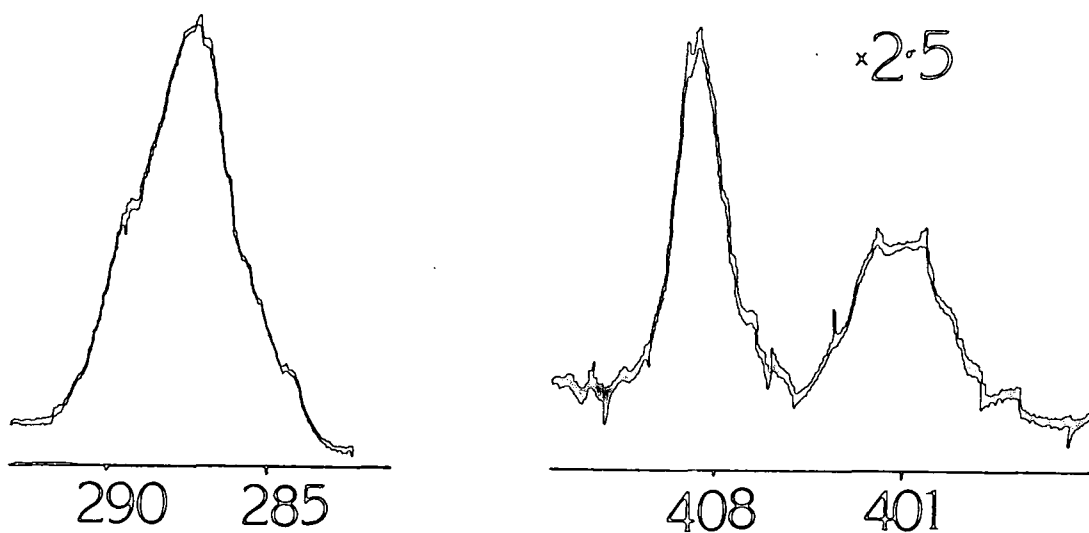

BINDING ENERGY (eV)

Figure 7.6 Core level spectra of a 2.7 DOS cellulose nitrate before and after treatment with an argon plasma.

7.3.5 A Study of the Reactions of Cellulose Nitrate in Hydrogen Plasmas.

A 2.2 DOS cellulose nitrate has been etched in a 5 W H₂ plasma. There was very little change in sample weight with treatment and it was concluded that no significant etch of the sample had occurred. The N_{1s} and C_{1s} core levels were monitored. After 1 hours exposure no nitrate ester could be detected by MgKα x-rays. From the core level area of the new nitrogen peak it is clear that (again) conversion is not a 1:1 process.

7.3.6 A Study of Etch Rate with DOS.

In Figure 7.7 the etch rate of two cellulose nitrates of DOS 1.85 and 2.66 are compared for treatment with a 100 W oxygen plasma. Both samples were prepared in dichloromethane/nitric acid mixes.

Initially the % weight loss from both samples with time is linear; however, at longer exposure times (> 30 minutes) the etch rate in both samples was observed to increase dramatically with no visible signs of combustion in the etched materials. This is not shown in Figure 7.7. There are two possible explanations for the dramatic increase in etch rate with exposure time:-

(i) an increase in the surface area of the material as it etches,

(ii) internal heating in the sample, or some form of autocatalysis.

From the data presently available it is not possible to elucidate the mechanism responsible for the dramatic increases in etch rate.

From Figures 7.3 and 7.7 it can be appreciated that DOS does have an appreciable effect on the initial etch rate, see Table 7.3.

Table 7.3 Etch Rate with DOS

<u>DOS of Cellulose Nitrate</u>	<u>% weight loss/minute</u>
2.73	2.3
2.65	2.0
1.80	1.5

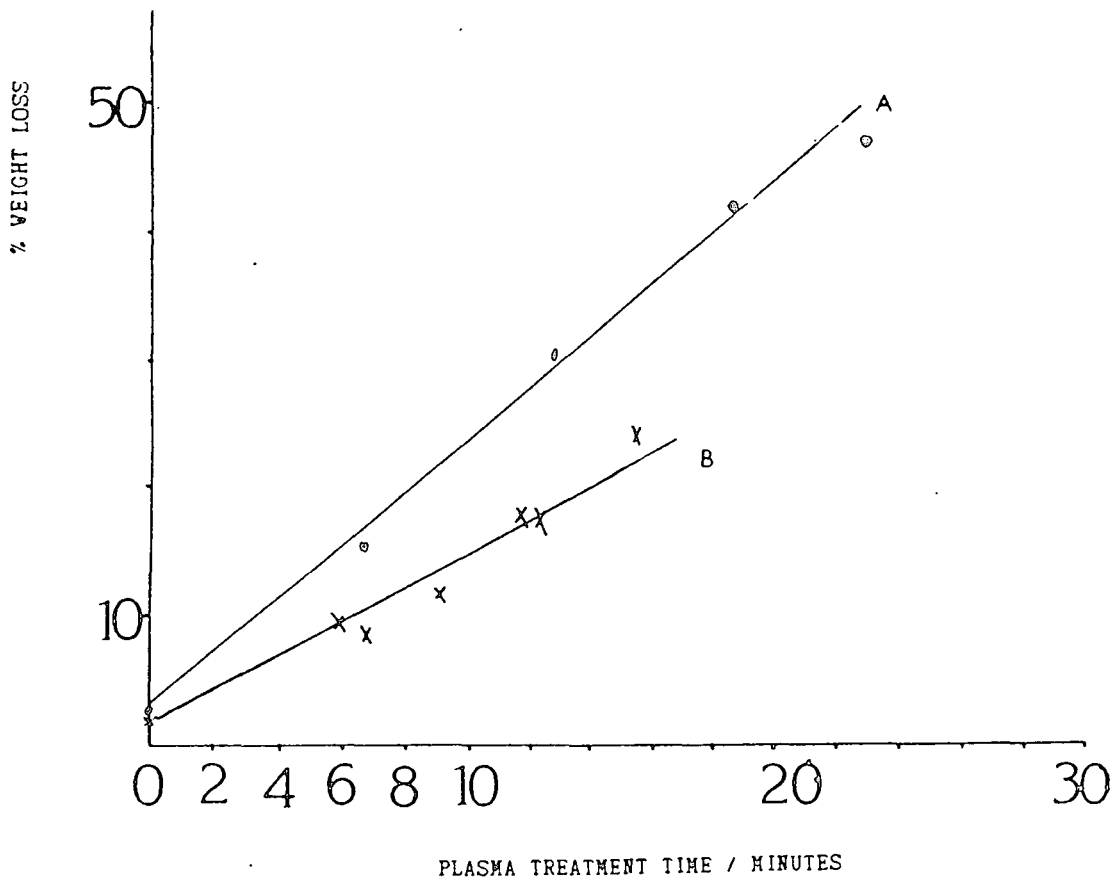

A = Cellulose Nitrate DOS = 2.66

B = Cellulose Nitrate DOS = 1.85

Figure 7.7 % Weight Loss with time for 2 different DOS cellulose nitrates (dichloromethane/nitric acid prepared).

7. 3.7 Summary

From the results presented above, it appears that the preparation and DOS of a cellulose nitrate influence the etch rate and extent of etch achieved in oxygen plasmas.

From ESCA studies of etched materials it is apparent that in oxygen, argon and hydrogen plasmas there is conversion of the nitrate functionality to a new nitrogen functionality which appears at lower binding energy. In argon and hydrogen plasmas this conversion is complete at the cellulose nitrate surface, but no significant etch of the fibre occurs.

References

- 1 M.W. Geis, T.N. Randall, T.F. Deutsch, P.D. DeGraff, K.E. Krohn and C.A. Stern, Applied Phys. Letters, 1983, 43(1), 74.
- 2 K. Harakawa, Y. Yasuoka, K. Gamo and S. Namba, J. Vac. Sci. Techn. B, 1986, Vol 4, No. 1, 355.
- 3 M.W. Geis, J.N. Randall, R.W. Mountain, J.D. Woodhouse, E.I. Bromley, D.K. Astolfi and N.P. Economou, J. Vac. Techn. B, 1985, Vol 3, No. 1, 343.
- 4 R.G. Poulsen, J. Vac. Sci. Techn., 1977, 14 (1), 266.

APPENDICES

APPENDIX ONE

A.1 The ESCA Spectrometer

An ESCA spectrometer comprises of essentially four components which are displayed in Figure A.1.1.

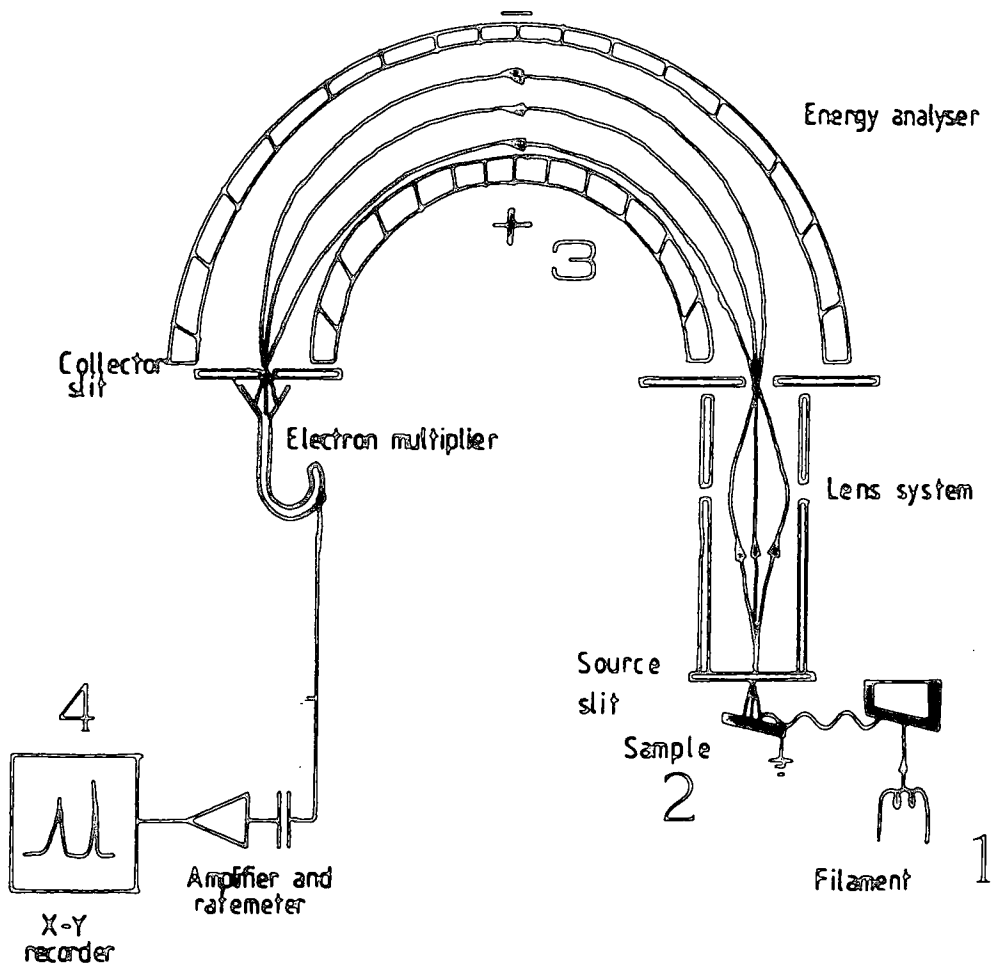

Principle of Operation

Figure A.1.1 Schematic of ESCA Instrumentation

- (1) X-ray source
- (2) Sample Chamber
- (3) Electron Energy Analyser
- (4) Electron Detection and Data Handling

A.1.1 X-ray source

Both the Kratos ES200 and ES300 electron spectrometers have an X-ray gun of the Henke or hidden filament type. The ES200 spectrometer is equipped with a single Mg_{K α} ($h\nu = 1253.6$ eV) source driven by a Marconi Elliott GX5 high voltage supply with an integrally variable voltage in the region of 0-60KV and 0.80mA emission current. Under normal working conditions the X-ray flux is of the order of 0.1 rads s^{-1} . The ES300 spectrometer is equipped with a dual-anode x-ray gun, with magnesium and titanium targets and a monochromatised Al_{K α} source.

The K $\alpha_{1,2}$ emission line from the Mg anode is employed for the ESCA experiment. In addition to the K $\alpha_{1,2}$ line a series of satellites are also present. The position and relative intensity of these satellites to the major peak are given below in Table A.1.

TABLE A.1 X-ray Satellite Energies and Intensities

	K α .	$\alpha_{1,2}$	α_3	α_4	α_5	α_6	β
Mg	Displacement (eV)	0	8.4	10.2	17.5	20.0	48.5
	Relative intensity	100	8.0	4.1	0.55	0.45	0.5

A.1.2 Sample Analysis Chamber

In Figures A.1.2 and A.1.3 the sample analysis chambers are shown schematically for the ES200 and ES300 electron spectrometers. The sample chambers are, in each case, equipped with a variety of access and view ports. In each case, fast entry insertion locks permit rapid sample introduction.

- A. Analyser. B. To Pumping. C. Catcher Tray.
 D. Penning Gauge. F. AG5 Ion Gun and Wien Filter.
 H. Viewport. I. Sample Insertion Lock. J. Insertion
 Lock for Reservoir Shaft. K. Unused. L. Viewport.
 M. To Monochromated $Al_{K\alpha_{1,2}}$ Source. P. Insertion Probe.
 S. Sample in Analysis
 position in front
 of X-ray source.

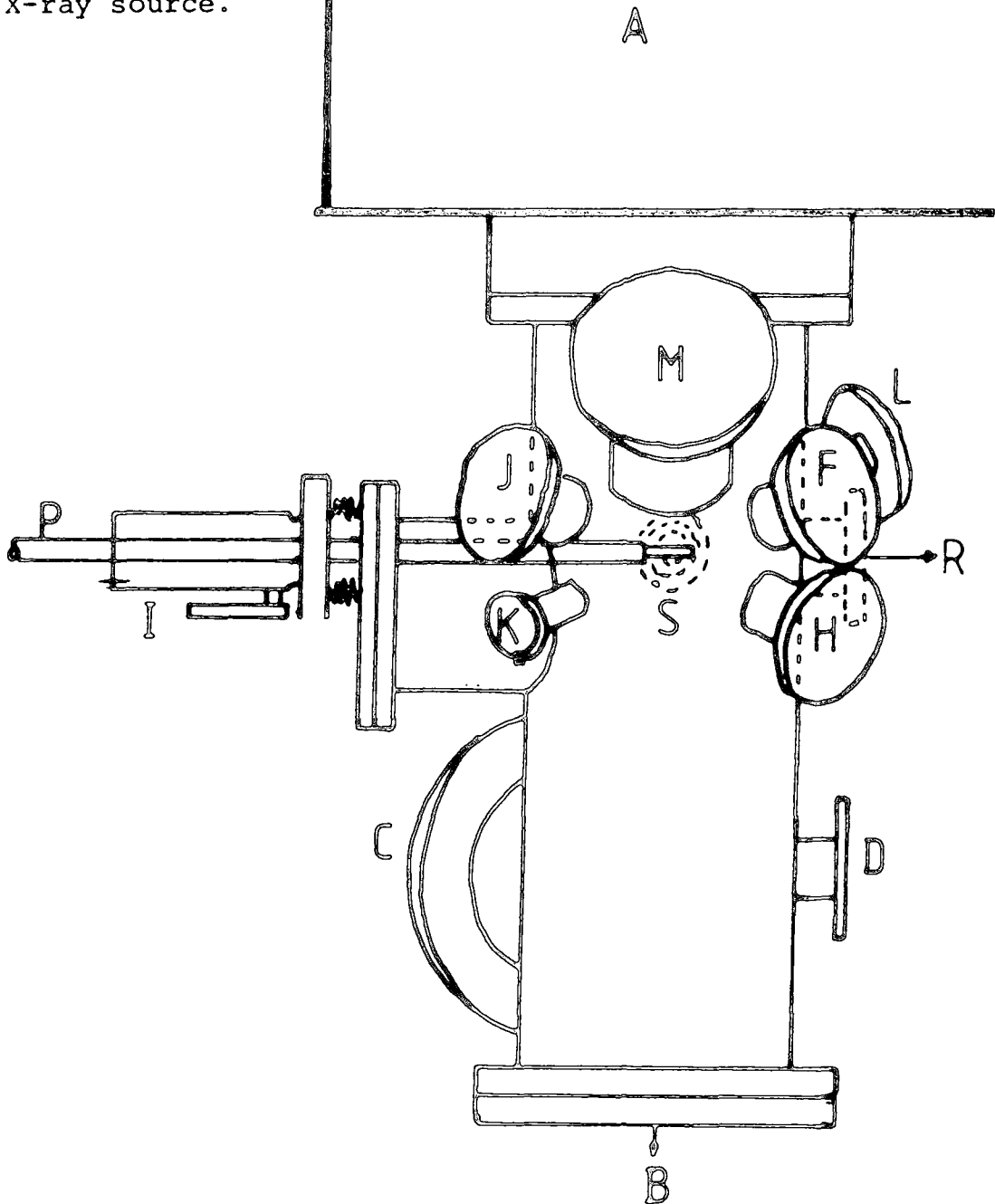

Figure A.1.3 Schematic of ES300 Sample Analysis Chamber

- A. Analyser. B. $Mg_{K\alpha}$ X-ray Source.
 C. $Al_{K\alpha}$ X-ray Source. M. Monochromator.
 S. Sample Analysis Position. V. Viewport.

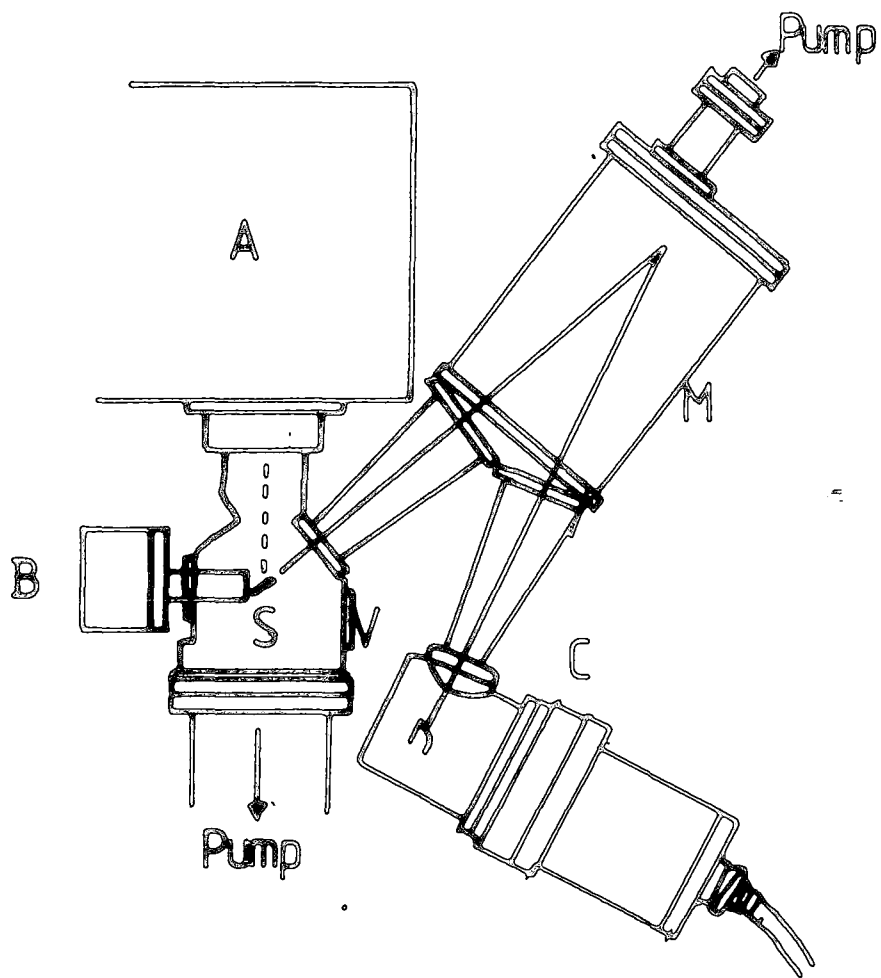

Figure A.1.2 Schematic of ES200 Sample Analysis Chamber

The ES200 sample chamber and analyser are pumped independently by liquid nitrogen cooled diffusion pumps, as is the x-ray source, giving a typical base pressure of 2×10^{-8} torr.

The ES300 spectrometer sample and analyser regions are pumped electrically by turbomolecular pumps. The x-ray gun and monochromator are pumped by small ion pumps. The typical base pressure of this system is 2×10^{-9} torr.

On the ES300 there is also a preparation chamber pumped by an Edwards EO4 diffusion pump with a long life cold trap backed by an Edwards EDM6 rotary pump.

A.1.3 Electron Energy Analyser

Both the ES200 and the ES300 spectrometers employ hemispherical double focussing analysers, mu-metal shielded, based upon the principle described by Purcell.¹ The resolution of the analysers is better than 1 in 10^4 . The analyser resolution is related to R, the mean radius of the hemispheres, and the combined width of the source and collector slits, W, by $\frac{\Delta E}{E} = \frac{W}{R}$.

A focussing and retarding lens arrangement is used to reduce the velocity of the electrons prior to entry, thus reducing the resolution requirements of the analyser. The analyser can be operated in two modes: (A) The retarding potential² applied to the lens is scanned and the pass energy as dictated by the potential applied across the hemispheres, is kept constant; or

(B) Scanning the retarding potential and the potential between the analyser hemispheres in unison, keeping a constant ratio between the two potentials.

The first method is referred to as the Fixed Analyser Transmission (FAT) mode and has greater sensitivity at lower kinetic energy ($S \propto 1/E$), resolution being fixed throughout the scan range. The second, the Fixed Retardation Ratio (FRR) mode has greater sensitivity at higher kinetic energies ($S \propto E$), resolution is not constant over the scan range.

A.1.4. Electron Detection and Data Acquisition

Electrons emerging from the exit slits of the analyser pass into the inlet aperture of a channeltron electron multiplier. These output pulses are amplified and fed to a data handling system. The ESCA spectrum can be generated in one of two ways:

- (1) by continuous scan - the pass energy of the analyser is linearly ramped with time from the starting KE; a ratemeter monitors the signals from the multiplier. Hence, a plot of the counts per second versus KE of the electrons may be plotted on a X-Y recorder.
- (2) by step scan - the pass energy is increased in preset increments. At each step, the counts are (a) measured for a fixed time, or (b) a fixed number of counts are timed. The data from such scans is stored in a multi-channel analyser or transferred directly to a mini or micro-computer.

The spectrometers used in this study were both operated in analogue and digital mode. The ES200 spectrometer was linked up to a BBC microcomputer, the ES300 to a DS300 data station.

The DS300 data system is based on an LSI-11 minicomputer running under RT11. Data acquired is stored on floppy disc. In addition to controlling the data acquisition it provides for the simultaneous analysis of data.

The data analysis package also facilitates the addition, subtraction, comparison, differentiation and integration of spectra, the subtraction of satellites from the spectra and a peak fitting / synthesis package.

The programme employed for data acquisition and analysis on the ES200 was written by Dr. C. Davies.

B The Fundamental Electronic Process involved in ESCA .

B.1.1. Photoionization

When a molecule is irradiated with a monoenergetic beam of photons, photoejection of electrons with kinetic energies less than the photon energies result.³ The total kinetic energy (KE) of the ejected electron is given by the equation:

$$KE = h\nu - BE - E_r.$$

where h = Planck's constant,

ν = frequency of incident radiation,

B.E. = binding energy of photoemitted electron,

E_r = recoil energy of atom or molecule.

Siegbahn⁴ and co-workers have shown that recoil energy is negligible in routine ESCA studies employing Mg_K or Al_K x-rays.

The lifetime of the corehole states formed by the photoionization event are typically 10^{-14} - 10^{-15} seconds.⁵

B.1.2. Processes Accompanying the Photoionization Event

The initial photoionization event may be accompanied by a variety of processes. Slow processes such as X-ray fluorescence and Auger electron emission have a negligible effect on the kinetic energy of the photoejected electron.⁶ Electronic relaxation processes, shake up, shake off and interaction of conduction electrons with the corehole occur on a similar time scale and therefore affect the kinetic energy of the photoemitted electron.⁷⁻⁹ These primary and secondary decay processes are illustrated in Figure

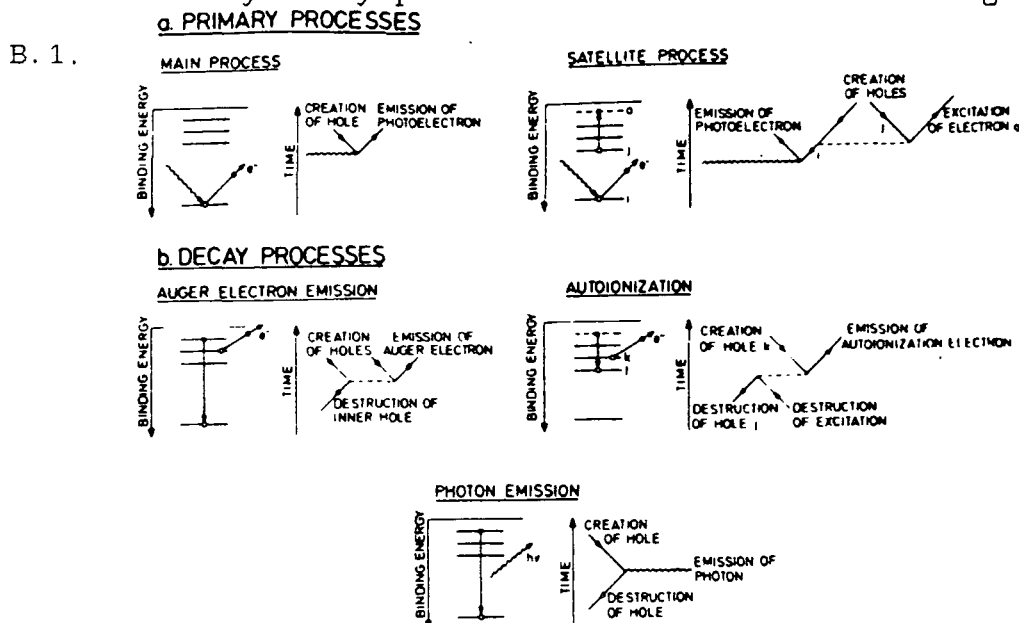

Figure B.1 The Photoionization Event and Accompanying Processes

B.2 Features of ESCA Spectra

B.2.1 Chemical Shifts

The binding energy of core level electrons in an atom are essentially characteristic of that particular element.¹³ The core level electrons are localised and tightly bound and, as such, do not take part in the bonding. They are, however, sensitive to local environment of an atom and small changes in the chemical environment of an atom give rise to measureable changes in the binding energy of the photoemitted electron.

A study of shifts in the core levels as a function of substituent for systems pertinent to this thesis was presented in Chapter 2, Table 2.3.

A variety of approaches exist for the calculation of chemical shifts.¹⁴

B.2.2 Fine Structure

There are three types of splitting that can occur in ESCA:¹⁵ multiplet splitting,^{16,17} spin orbit splitting^{18,20} and electrostatic splitting. Only spin-orbit interactions are particularly relevant to this thesis.

Spin-orbit splitting occurs when the quantum number (l) is greater than 1 (i.e., p, d and f). Figure B.2 shows an example of spin orbit splitting in the S_{2p} core level.

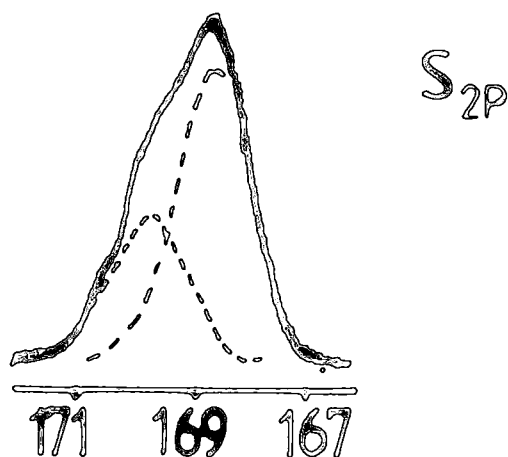

Figure B.2 Spin-Orbit Splitting in the S_{2p} core level

B.2.3 Sample Charging and Energy Referencing

"Sample charging" arises from the ability of an insulating sample to replace electrons lost by photoemission. An equilibrium situation is established when the photoemission current is balanced by the sample attracting electrons from its backing or by the capture of stray electrons from the vacuum system. As a result of photo irradiation the sample surface rises to a net positive potential.

In the case of polymer samples the easiest method of circumventing the problems of energy referencing caused by sample charging is by the use of a suitable reference. The most commonly used calibration point in polymeric

systems is the C_{1s} peak due to the CH_2 environments, either inherent in the sample or as a contaminant layer, at 285.0 eV.

A detailed study of the charging phenomena has been reported by Clark et al.^{21, 22}

B.2.4 Signal Intensities

For an infinitely thick, homogeneous sample, the inelastic photoionization peak intensity for the photoelectrons originating from a core level is given by:

$$dI_i = F\alpha_i N_i k_i e^{-x/\lambda_i} .dx.$$

where

- I_i = intensity arising from core level i .
- F_i = exciting incident photon flux.
- α_i = photoionisation cross-section of the core level i .
- k_i = spectrometer factor.
- N_i = number of atoms per unit volume on which the core level is localised.
- λ_i = inelastic mean free path of the emitted electron from core level i .

Integrating gives,

$$I_i = \int_0^{\infty} F \alpha_i N_i k_i e^{-x/\lambda_i} dx.$$

and
$$I_i = F \alpha_i N_i k_i \lambda_i$$

Examining these parameters further:

F, the X-ray flux depends primarily on the operating power and efficiency of the X-ray gun, α_i the cross section for photoionization for a given core level, i , describes the probability that a core level will be ionized when irradiated at a given energy. α_i is also dependent upon the angle of detection with respect to the angle of the incoming photons and hence is weighted to include only those electrons emitted within the solid angle of the analyser lens system. α_i is given by

$$\alpha_i = \frac{\alpha_i^{\text{TOT}}}{4\pi} \left[1 - \frac{1}{4} \beta_i (3\cos^2\phi - 1) \right]$$

where ϕ is the angle between the incident X-rays and the analyser slit. See Figure B.3

α_i^{TOT} is the total cross section of the core level i , and β_i the asymmetry parameter for that core level.²⁵ The cross section, α_i , can be calculated or determined experimentally.

K_i , the spectrometer factor is an instrumentally dependent parameter reflecting the efficiency of the detection system and the transmission of the analyser to electrons of various kinetic energies, and the solid angle of acceptance of the analyser.

λ_i , the inelastic electron mean free path, is defined as the distance in the solid that electrons of a

ANGULAR STUDIES

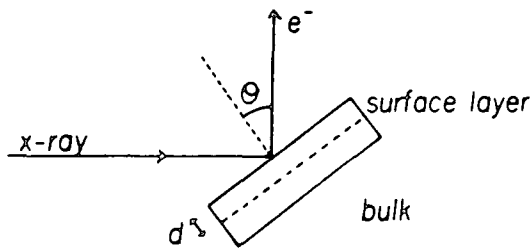

HOMOGENEOUS SAMPLE

$$I = f(\theta) F \alpha N K \lambda$$

where F is the x-ray flux

α is the cross section for photoionization

N is the number of atoms, on which the core level is localized, per unit volume

K is a spectrometer dependant factor

λ is the mean free path of the electrons

INHOMOGENEOUS SAMPLE

-for the surface layer

$$I = f(\theta) F \alpha N K \lambda (1 - e^{-d/\lambda \cos \theta})$$

-for the bulk

$$I = f(\theta) F \alpha N K \lambda e^{-d/\lambda \cos \theta}$$

Figure B.3 Schematic of sample geometry relative to the X-ray source and analyser

given energy can travel before 1/e of them have suffered energy loss through inelastic collision. λ_i is a function of electron energy.

Another useful quantity is the sampling depth, the depth from which 95% of the signal from a given core level arises. This is useful when discussing the surface sensitivity of ESCA.

N_i is the number of atoms, i , per unit volume. The relative intensities of core levels is related to the overall stoichiometry of the atoms in the surface. Hence, for two core levels, i and j

$$\frac{I_i}{I_j} = \frac{F\alpha_i N_i k_i \lambda_i}{F\alpha_j N_j k_j \lambda_j}$$

If i and j correspond to different chemical environments of the same core level, then

$$\frac{I_i}{I_j} = \frac{N_i}{N_j} \quad (F\alpha_i N_i k_i \lambda_i = F\alpha_j N_j k_j \lambda_j)$$

If, however, $i \neq j$ then

$$\frac{N_i}{N_j} = \frac{I_i}{I_j} \left[\frac{k_j \alpha_j \lambda_j}{k_i \alpha_i \lambda_i} \right]$$

The bracketed quantity is the sensitivity factor, this factor can be determined experimentally (see Chapter Two) or calculated.

B.2.5 Analytical Depth Profiling

From the above discussion it can easily be appreciated that by changing θ , the angle of the escaping electrons with respect to the direction normal to the sample surface, see Figure B.3, that the sampling depth in the solid can be altered. This is because of the short mean free paths of the photoejected electrons. However, this method of depth profiling will only work for flat surfaces.

To enable depth profiling of fibrous or powder samples a further technique can be employed. This is to use $Ti_{K\alpha}$ X-rays (4150 eV). If this X-ray source is used the kinetic energy of the photoejected electrons, from a particular core level, will be greater than the corresponding kinetic energy of electrons emitted under $Mg_{K\alpha}$ X-rays irradiation and the $Ti_{K\alpha}$ photoejected electrons will hence have a much greater mean free path through the solid.

Commonly there is contamination of a surface. If the contamination of the surface is uniform of a depth d and of differing composition to the subsurface then the signal arising from the contaminant overlayer can be expressed by:

$$I_i^{over} = F\alpha_i N_i k_i \lambda_i (1 - e^{-d/\lambda_i})$$

and the signal from the subsurface by:

$$I_j^{\text{sub}} = F\alpha_j N_j k_j \lambda_j (e^{-d/\lambda_j})$$

These equations are angularly dependent, i.e.

$$i.e. \quad I_i^{\text{over}} = F\alpha_i N_i k_i \lambda_i (1 - e^{-d/\lambda_i \cos\theta})$$

$$\text{and} \quad I_j^{\text{sub}} = F\alpha_j N_j k_j \lambda_j (e^{-d/\lambda_j \cos\theta})$$

Thus, it can be seen that as $\theta \rightarrow \pi/2$, the signal from the overlayer will dominate.

B.2.6. Linewidths and Lineshape Analysis

ESCA spectra have large inherent linewidths comparable in magnitude to the magnitude of the chemical shifts. The dominating contribution to the broad linewidths comes from the inherent linewidths of the polychromatic X-ray source normally used.

The measured linewidth for a core level maybe expressed as a convolution of several effects.

$$(\Delta E_m)^2 = (\Delta E_x)^2 + (\Delta E_s)^2 + (\Delta E_{cl})^2$$

where ΔE_m = observed full width at half maximum (FWHM) of the photoelectron peak.

ΔE_x = the FWHM of the exciting X-ray source *ca.* 0.7eV for $Mg_{k\alpha_{1,2}}$.

ΔE_s = spectrometer contribution to the FWHM (*i.e.* analyser aberrations, slit widths *etc.*).

ΔE_{cl} = natural line width of the core level. This also includes solid state broadening effects not directly associated with the life-time of the core-hole state for solid samples, including variations in chemical shift due to differences in lattice environments.

APPENDIX TWO

A.1 Kjeldahl Analysis for Nitrogen

The Kjeldahl nitrogen determinations reported in this thesis were performed according to a procedure developed at P.E.R.M.E., Waltham Abbey. As in all distillation methods the sample is first digested in acid or alkaline conditions to yield inorganic nitrates. This is then, if necessary, made alkaline and Devardas Alloy is added to reduce the nitrate to nitrite and finally ammonia. The ammonia is distilled into boric acid solution for titration with standard 0.1N hydrochloric acid. The digestion stage is the most critical, especially in the analysis of cellulose nitrates since some samples (>12.7% N) may not be fully digested by standard alkaline methods. Hence two procedures, designated A and B are adopted, depending on the estimated nitrogen content of the cellulose nitrate. These two methods are described below.

A.2 Method A. Alkaline Digestion for Samples <12.7% N

50-120mg of NC were weighed into a glass ampoule and then deposited into the base of a semi-micro flask. The ampoule was broken and 2.0mls of H₂O, 0.1mls of 30% H₂O₂ and 8.0mls of 20% NaOH were then added. The flask was then heated by ~100°C and maintained at this temperature for ~20 mins. to dissolve the sample. 20mls of H₂O were then added and the solution was heated again to ~100°C to destroy the remaining H₂O₂. After the mixture had cooled to ~30°C, 1.00±0.01 gms of Devardas Alloy (weighed into a glass ampoule) were deposited into the flask. The stream inlet tube was attached to the neck of the flask (as shown in the diagram), and the condenser

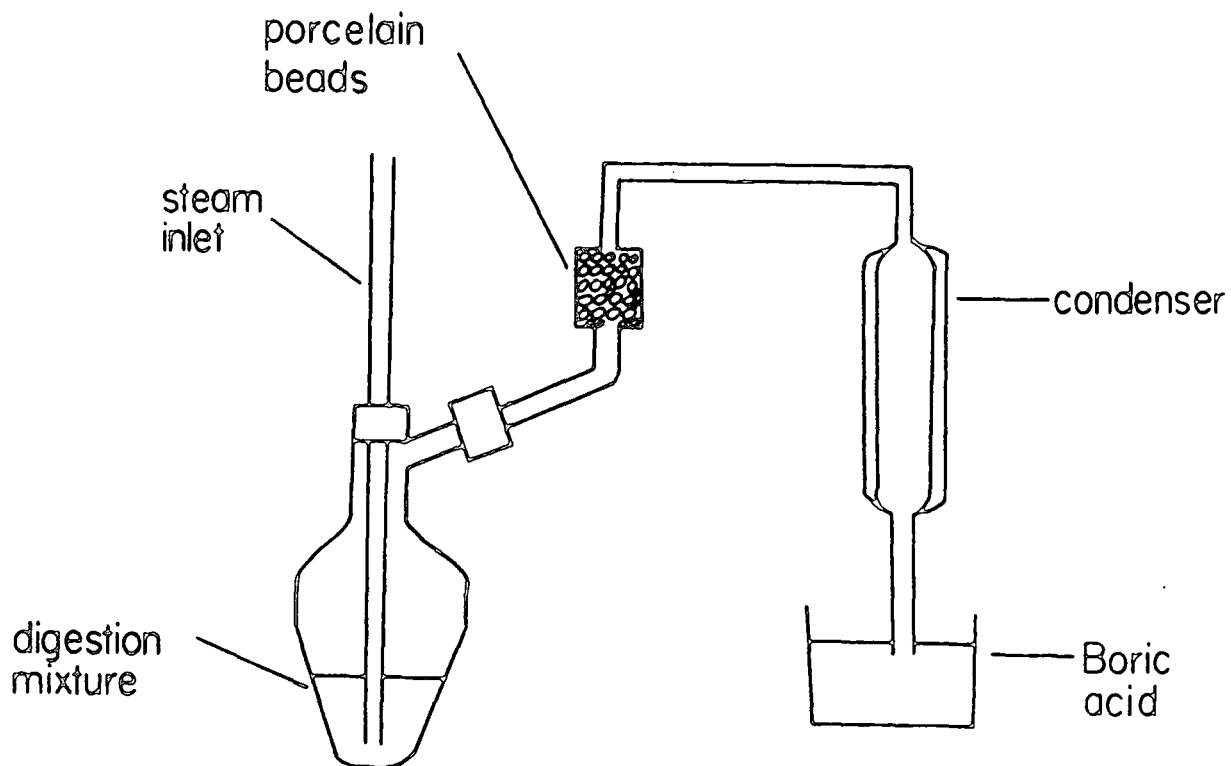

Fig. A.2.1 Schematic of apparatus for Kjeldahl analysis

outlet tube was allowed to dip ~10mm below the surface of the boric acid in the receiver flask (25mls of 4% Boric acid). The heating of the flask was controlled to prevent excessive foaming. The ammonia liberated was steam distilled over with ~50mls of H₂O and then titrated (using Bromocresol green as indicator) with 0.1N HCl. The volume of solution in the flask should remain constant during the distillation.

A.3 Method B. Samples 12.7% N Acid Digestion

50-120mg of NC weighed into the reaction flask and cooled in an ice-water bath. 2mls. of concentrated H_2SO_4 were added dropwise to the flask and left to dissolve the sample for 30-60 mins. The solution was then carefully diluted by adding 10gms. of crushed ice and 15-17 mls of 30% NaOH. Continued as in A.

Since Devardas Alloy has its own nitrogen content it is necessary to carry out a blank determination using all reagents except the NC for each distillation. The method is generally calibrated using Potassium Nitrate. The nitrogen content is quoted to two decimal places although the choice of the wrong digestion method can give inaccurate results.

CELLULOSE NITRATE
DEGREE OF SUBSTITUTION
VS. PERCENTAGE NITROGEN

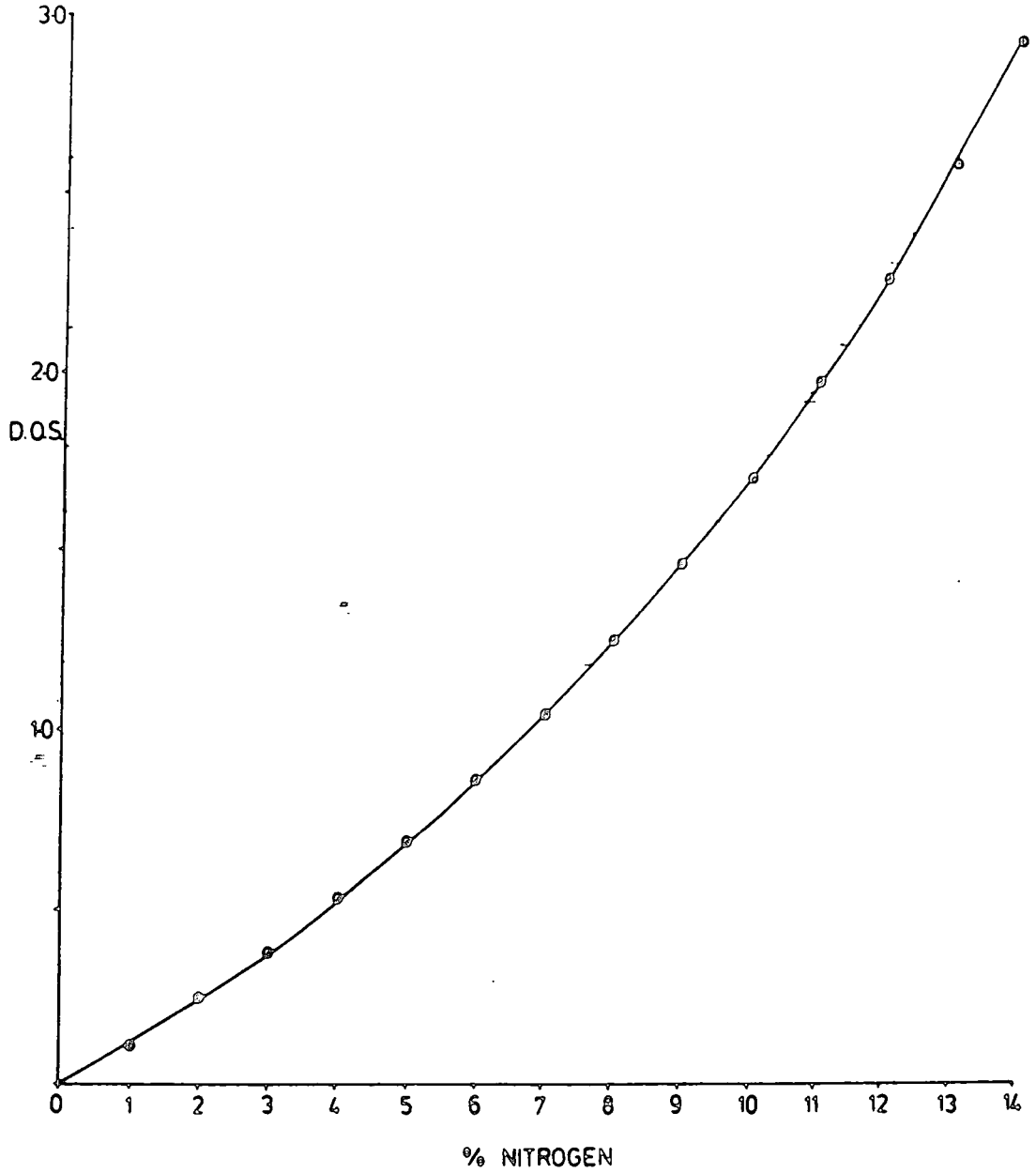

Fig. A.2.2 Graph of DOS versus % Nitrogen.

REFERENCES

- 1 E.M. Purcell, Phys. Rev., 1938, 54, 818.
- 2 J.C. Helmer and N.H. Weichert, Appl. Phys. Lett., 1968, 13, 268.
- 3 K. Siegbahn, C. Nordling, A. Fahlman et al, 'ESCA, Atomic, Molecular and Solid State Structure Studied by Means of Electron Spectroscopy', Almquist and Wiksells, Uppsala, 1967.
- 4 K. Siegbahn, C. Nordling, G. Johansson et al 'ESCA Applied to Free Molecules', North-Holland Publ. Co., Amsterdam.
- 5 D.T. Clark, 'Structure and Bonding in Polymers as Revealed by ESCA' in 'Electronic Structures of Polymers and Molecular Crystals', Eds. J. Ladik and J.M. Andre., Plenum Press, N.Y. (1975).
- 6 A. Dilks, Ph.D. Thesis, Univ. of Durham, 1977.
- 7 A. Rosen and I. Lindgren, Phys. Rev., 1968, 176, 114.
- 8 P.S. Bagus, Phys. Rev., 1965, 139A, 619.
- 9 D.A. Shirley in 'Advances in Chemical Physics', 23, 85, Ed. I. Prigogine and S.A. Rice, Wiley, N.Y., 1973.
- 10 U. Gelius and K. Siegbahn, Farad. Disc. Chem. Soc., 1972, 54, 257.
- 11 L.C. Snyder, J. Chem. Phys., 1971, 55, 95.
- 12 D.B. Adams and D.T. Clark, Theoret. Chim. Acta, 1973, 31, 171.
- 13 D.T. Clark, 'Chemical Aspects of ESCA' in 'Electron Emission Spectroscopy' Ed. W. Dekeyser, D. Reider, D. Reider Publ. Co., Dordrecht, Holland, 373, 1973.
- 14 C.S. Fardley in 'Electron Spectroscopy', Ed. D.A Shirley, North Holland Publ. Co., 1972.
- 15 A.H.K. Fowler, Ph.D. Thesis, Univ. of Durham, 1984.
- 16 K. Siegbahn, C. Nordling and Fahlman, cf. ref. 3.
- 17 D.W. Davies and D.A. Shirley, J. Chem. Phys., 1972, 56, 669.
- 19 P.W. Atkins, 'Molecular Quantum Mechanics', Oxford Univ. Press., London, 1970.
- 20 F.A. Cotton and G. Wilkinson, 'Advanced Inorganic Chemistry', J. Wiley and Sons, New York, 1972.

- 21 D.T. Clark, A. Dilks, D. Shuttleworth and H.R. Thomas, J. Polym. Sci., Polym. Chem. Ed., 1979, 17, 677.
- 22 D.T. Clark, Physica Scripta (Sweden), 1977, 16, 307.
- 23 T.A. Carlson and G.E. McGuire, J. Elect. Spec., 1974, 4, 93.
- 24 C.S. Fadley, R.J. Baird and W. Siekhaus, J. Elect. Spec., 1974, 4, 93.
- 25 J.J. Huang, J.W. Rabelais and F.O. Ellison, J. Elect. Spec. 1975, 6, 85.

