



Durham E-Theses

Nucleoside and nucleotide analogues containing fluorine

Parkinson, Nigel Christopher

How to cite:

Parkinson, Nigel Christopher (1993) *Nucleoside and nucleotide analogues containing fluorine*, Durham theses, Durham University. Available at Durham E-Theses Online: <http://etheses.dur.ac.uk/5639/>

Use policy

The full-text may be used and/or reproduced, and given to third parties in any format or medium, without prior permission or charge, for personal research or study, educational, or not-for-profit purposes provided that:

- a full bibliographic reference is made to the original source
- a [link](#) is made to the metadata record in Durham E-Theses
- the full-text is not changed in any way

The full-text must not be sold in any format or medium without the formal permission of the copyright holders.

Please consult the [full Durham E-Theses policy](#) for further details.

The copyright of this thesis rests with the author.
No quotation from it should be published without
his prior written consent and information derived
from it should be acknowledged.

UNIVERSITY OF DURHAM

A THESIS
entitled

**NUCLEOSIDE AND NUCLEOTIDE ANALOGUES CONTAINING
FLUORINE**

submitted by

NIGEL CHRISTOPHER PARKINSON B.Sc.
(Hatfield College)

A candidate for the degree of Doctor of Philosophy
1993



22 FEB 1994

**To my parents
and Lynn**

Acknowledgements

I would like to thank my joint supervisors Professor Dick Chambers and Doctor David O'Hagan for support and advice during the course of my research.

Thanks also to my industrial supervisor Doctor Ann Parkin for chemicals, biological tests and an enjoyable three months at SmithKline Beecham. Many thanks to S.E.R.C. and SmithKline Beecham for funding my Ph.D. and other people of note at Beechams especially Martin, Jo, Tansy and not forgetting Mark and Jamie.

The work in this thesis would not have been possible without the following technical members of the department: Dr. M Jones, Mr. V.J. McNeilly and Miss. L. M. Turner (Mass Spectrometry); Dr. R. S. Matthews, Dr. A. Kenwright and Mrs. J. M. Say (NMR); Mr. L. W. Lauchlan (Chromatography); Mrs. M. Cocks and Mrs. J. Dostal (Elemental Analysis); Mr. D. Hunter (High Pressure Techniques); Mr R. Hart and Mr. G Haswell (Glassblowing); Mr J Lincoln (Storekeeper); Maureen and the tea ladies (Cleaning and Tea), special mention for Mr Tom Holmes (Special Chemistry).

To Mr. S. Whitehead (Schering Agro. Chem.) thanks for the Mass Spectra.

Last but not least thanks to all my mates at Durham past and present especially members of CG115, Drobssquad and Dr. Proctor for challenging chemical problems!

Memorandum

The work described in this thesis was carried out in the University of Durham between October 1989 and September 1992. This thesis is the work of the author, except where acknowledged by reference, and has not been submitted for any other degree.

The work has been presented, in part, by the author at:

I. C. I. Poster Session, Durham University, December 1990.

Nomenclature

Due to the length of nucleoside and nucleotide names and structures a number of abbreviations have been used namely:

A for adenine

C for cytosine

U for uracil

T for thymine

G for guanine

I for inosine

5FU for 5-fluorouracil

all other abbreviations used in this thesis can be found in the Journal of the Chemical Society's instructions for authors (1992).

ABSTRACT

NUCLEOSIDE AND NUCLEOTIDE ANALOGUES CONTAINING FLUORINE

by Nigel Christopher Parkinson

The work contained in this thesis is divided into four sections detailing the formation of (diethoxyphosphinyl)difluoromethylene substituted cycloalkanes and alkenes and their chemistry, as well as the syntheses of purine and pyrimidine substituted polyfluoroethers:

(i) The methodology for the introduction of the (diethoxyphosphinyl)difluoromethylene group was studied and extended, with specific reference to cyclic systems. The group was successfully introduced into cyclic alkenes with (diethoxyphosphinyl)difluoromethylene zinc bromide and saturated systems with (diethoxyphosphinyl)difluoromethyl lithium. The organolithium reagent was also shown to be capable of ring opening epoxides to yield alcohols;

(ii) The (diethoxyphosphinyl)difluoromethylene substituted cyclohexene derivative was further functionalised in a four step process to a new class of adenine and guanine based nucleotide analogues. Model studies were carried out on the (diethoxyphosphinyl)-difluoromethylene substituted cyclohexene derivative with a variety of reagents to introduce functionality at the double bond;

(iii) The radical addition of (diethoxyphosphinyl)bromodifluoromethane and (diethoxyphosphinyl)difluoroiodomethane to cycloalkenes using ultraviolet photolysis and gamma-ray initiation were successfully carried out, thus opening up a new route into (diethoxyphosphinyl)difluoromethylene substituted cycloalkanes;

(iv) The synthesis of purine and pyrimidine nucleoside analogues is described *via* the coupling of 2-amino-6-chloropurine, 6-chloropurine, silylated 5-fluorouracil and silylated uracil to various α -haloethers. The α -haloethers having previously been synthesised by radical chlorination of both cyclic and acyclic polyfluoroethers.

CONTENTS**Chapter I****Fluorinated Nucleoside and Nucleotide Analogues**

I.A General Introduction	1
I.B Fluorine in Biological Systems	1
I.B.1 Fluorine as a Hydrogen Substitute.....	2
I.B.2 Fluorine as an Oxygen Mimic	3
I.B.3 Fluorine in Transport Mechanisms	4
I.C Fluorine Containing Nucleosides.....	4
I.C.1 Introduction.....	4
I.C.2 Base Modified Derivatives.....	5
I.C.2.a Pyrimidines.....	5
I.C.2.a.(i) Modification at C5 in the Ring	5
I.C.2.a.(ii) Modification at O4 Position.....	8
I.C.2.a.(iii) Modification at N3 in the Ring.....	9
I.C.2.b Purines.....	9
I.C.2.b.(i) Modification at C2 in the ring	9
I.C.2.b.(ii) Modification at C6 in the ring	11
I.C.2.b.(iii) Modification at C8 in the ring.....	12
I.C.3 Sugar Modified Derivatives.....	12
I.C.3.a C2' Fluoronucleosides.....	12
I.C.3.b C3' Fluoronucleosides.....	18
I.C.3.c C4' Fluoronucleosides.....	20
I.C.3.d C5' Fluoronucleosides.....	22
I.C.3.e C6' Fluoronucleosides.....	24
I.C.4 Acyclic Fluoronucleosides.....	26
I.D. Fluorine Containing Nucleotides	27
I.D.1 Introduction.....	27
I.D.2 Fluorophosphates.....	28
I.D.3 Fluoroalkylphosphonates	30
I.D.3.a α -, α,α -Fluoromethylphosphonates.....	30
I.D.3.b α,β -, β,γ -Fluorophosphonates.....	32
I.D.4 Fluoroalkylphosphates	35
I.E. Fluorine Containing Oligonucleotides.....	36
I.E.1 Introduction.....	36
I.E.2 Poly(2'-Fluoronucleotides).....	36
I.E.3 Fluoroalkylphosphonate Dimers	37

Chapter II**The (Diethoxyphosphinyl)difluoromethylene Group**

II.A Introduction	38
II.A.1 Organometallic Reagents.....	38
II.A.1.a (Diethoxyphosphinyl)difluoromethylene Reagents.....	38
II.A.1.b Reaction of Perfluoroalkyl Grignard Reagents with Diethyl Chlorophosphate.....	40
II.A.2 Electrophilic Fluorinating Agents	40
II.A.2.a Perchloryl Fluoride.....	40
II.A.2.b <i>N</i> -Fluorobenzenesulphonamide (99)	40
II.B The Chemistry of (Diethoxyphosphinyl)difluoromethylene Zinc Bromide (95).....	41
II.B.1 Reaction of Benzyl Bromide With (95).....	41
II.B.2 Reactions of Allylic Bromides With (95).....	42
II.B.2.a Preparation of 3-Bromocycloalkenes.....	42
II.B.2.b The Reaction of Bromocycloalkenes With (95).....	43

II.B.2.c Reaction Mechanism of Allylic and Propagyl Halides With (95)	44
II.B.2.d Stereochemistry for the Reaction of Allylic Halides With (95)	45
II.B.3 Attempted Palladium (0) Catalysed Reactions of (95) with Allylic Acetates and Phenyl Allyl Ethers	49
II.B.3.a The Attempted Palladium (0) Catalysed Reaction of (95) with <i>Cis</i> -Acetoxy-5-carbomethoxy-1-cyclohexene (112)	50
II.B.3.b The Attempted Palladium (0) Catalysed Reaction of (95) with 3-Phenoxy-cyclopentene (114)	51
II.B.3.c The Attempted Palladium (0) Catalysed Reaction of (95) with 6-Oxabicyclo[3.2.1]octen-5-one (113)	52
II.B.3.d Conclusion	52
II.B.4 General Conclusion	52
II.C The Chemistry of (Diethoxyphosphinyl)difluoromethylene Lithium (96)	53
II.C.1 Generation of the Lithium Salt (96)	53
II.C.2 The Reaction of (96) with Halides	54
II.C.2.a Saturated Halides	54
II.C.2.b Benzylic and Allylic Halides	55
II.C.3 Displacement of Other Leaving Groups by (96)	56
II.C.4 Reaction of (96) with Oxirane	57
II.C.5 General Conclusion	58
II.D Reactions of 3-[(Diethoxyphosphinyl)difluoromethyl]cyclohexene (107)	58
II.D.1 The Preparation of 1-[(diethoxyphosphinyl)difluoromethyl]-2,3-epoxycyclohexene (127)	58
II.D.1.a The Stereochemistry of 1-[(diethoxyphosphinyl)difluoromethyl]-2,3-epoxycyclohexene (127)	59
II.D.1.b The Attempted Epoxide Cleavage of (127) with DAST	60
II.D.2 The Attempted Preparation of 1-[(diethoxyphosphinyl)difluoromethyl]-2,3- <i>cis</i> -dihydroxycyclohexane (128)	61
II.D.2.a <i>Via</i> a Catalytic Osmium Tetroxide/ <i>N</i> -Methyl-Morpholine- <i>N</i> -Oxide System	61
II.D.2.b <i>Via</i> the Woodward Method	62
II.D.3 Conclusion	62

Chapter III

The Synthesis of 3-(*N*9-Adenyl)-6-[(dihydroxyphosphinyl)difluoromethyl]cyclohexene and 3-(*N*9-Guanyl)-6-[(dihydroxyphosphinyl)difluoromethyl]cyclohexene

III.A Introduction	63
III.B Effect of Ring Size in Carbocycles	63
III.C Effect of Unsaturation	64
III.D Synthesis of 3-(<i>N</i> 9-Adenyl)-6-[(dihydroxyphosphinyl)difluoromethyl]cyclohexene (139) and 3-(<i>N</i> 9-Guanyl)-6-[(dihydroxyphosphinyl)difluoromethyl]cyclohexene (140)	65
III.D.1 Method A	
<i>Via</i> Allylic Oxidation of 3-[(Diethoxyphosphinyl)difluoromethyl]cyclohexene (107)	67
III.D.2 Method B	
<i>Via</i> Allylic Bromination of 3-[(Diethoxyphosphinyl)difluoromethyl]cyclohexene (107)	68
III.D.2.a Reaction of 3-Bromo-6-[(diethoxyphosphinyl)difluoromethyl]cyclohexene (142) with 6-Chloropurine (144)	71
III.D.2.b Geometry of the Isomers of 3-[<i>N</i> 9-(6-Chloropurinyl)]-6-[(diethoxyphosphinyl)difluoromethyl]cyclohexene (145)	71

III.D.2.c Synthesis of 3-(<i>N</i> 9-Adenyl)-6-[(diethoxyphosphinyl)-difluoromethyl]cyclohexene (147)	76
III.D.2.d Deprotection of 3-(<i>N</i> 9-Adenyl)-6-[(diethoxyphosphinyl)difluoromethyl]cyclohexene (145).....	77
III.D.2.e Reaction of 3-Bromo-6-[(diethoxyphosphinyl)difluoromethyl]cyclohexene (142) with 2-Amino-6-chloropurine (148)	78
III.D.2.f Synthesis of 3-(<i>N</i> 9-Guanyl)-6-[(diethoxyphosphinyl)-difluoromethyl]cyclohexene (150)	79
III.D.2.g Deprotection of 3-(<i>N</i> 9-Guanyl)-6-[(diethoxyphosphinyl)difluoromethyl]cyclohexene (151).....	80
III.E Biological Test Data on 3-(<i>N</i> 9-Adenyl)-6-[(dihydroxyphosphinyl)-difluoromethyl]cyclohexene (139) and 3-(<i>N</i> 9-Guanyl)-6-[(dihydroxyphosphinyl)difluoromethyl]cyclohexene (140).....	80

Chapter IV

Free Radical Reactions of (Diethoxyphosphinyl)difluoromethylene Halides

IV.A Introduction	81
IV.B Free Radical Addition Processes	81
IV.B.1 Utilising Gamma-ray Irradiation	82
IV.B.1.a The Reaction of Cyclohexene and (Diethoxyphosphinyl)-bromodifluoromethane (94).....	82
IV.B.1.b The Synthesis of (Dihydroxyphosphinyl)bromodifluoromethane (154) and Reaction with Cyclohexene	83
IV.B.1.c The Stereochemistry of the Addition of (Diethoxyphosphinyl)bromodifluoromethane (94) to Cyclohexene	84
IV.B.2 Utilising Ultraviolet Irradiation.....	85
IV.B.2.a The Reaction of Cyclohexene and (Diethoxyphosphinyl)-bromodifluoromethane (94).....	86
IV.B.2.b The Reaction of Cycloalkenes and (Diethoxyphosphinyl)difluoroiodomethane (118).....	87
IV.B.2.c The Reaction of Furanyl Systems with (Diethoxyphosphinyl)difluoroiodomethane (118).....	89
IV.C S.E.T. Processes.....	90
IV.C.1 Palladium (0) Catalysed Coupling	90
IV.C.2 Copper Catalysed Coupling of (Diethoxyphosphinyl)difluorohalides to Cycloalkenes.....	90
IV.C.3 Samarium Diodide Catalysed Coupling of (Diethoxyphosphinyl)-difluorohalides to Cycloalkenes	91
IV.C.3.a Attempted Reaction of (Diethoxyphosphinyl)bromodifluoromethane (94) with Cyclohexene	91
IV.C.3.b Attempted Reaction of (Diethoxyphosphinyl)difluoroiodomethane (118) with Cyclohexene	92
IV.C.3.c Conclusion	93

Chapter V

The Synthesis of Purine and Pyrimidine Polyfluoronucleosides

V.A Introduction	94
V.B 5'-Deoxynucleoside Derivatives of 5-Fluorouracil.....	95
V.C Free Radical Formation of Polyfluoroalkyl Ethers	96
V.C.1 Factors Affecting Regiochemistry and Stereochemistry of Free Radical Addition.....	97

V.C.2 Acyclic Fluorinated Ethers	98
V.C.2.a Competition Studies of Hexafluoropropene, Pentafluoropropene, and Trifluoropropene with Dimethyl Ether.....	100
V.C.3 Cyclic Fluorinated Ethers	102
V.C.3.a The Synthesis of Cyclic Fluorinated Ethers	102
V.C.3.b Stereochemistry of Cyclic Fluorinated Ethers.....	105
V.D Halogenation of Fluorinated Ethers	106
V.D.1 Introduction.....	106
V.D.2 Regioselectivity of Halogenation.....	107
V.D.3 Spectrometric Assignment of Polyfluorinated α -Haloethers	109
V.E The Coupling of Nucleoside Bases to Polyfluorinated α -Haloethers.....	110
V.E.1 Introduction.....	110
V.E.2 Methods of Coupling Pyrimidine Bases.....	110
V.E.2.a Silylation of Uracil and 5-Fluorouracil.....	111
V.E.2.b Coupling of Silylated Uracil (190) and 5-Fluorouracil (191) to Polyfluorinated α -Haloethers.....	111
V.E.2.c Stereochemistry of the Pyrimidine Substituted Polyfluorinated α -Haloethers	112
V.F The Synthesis of 2-(5-Fluorouracyl)-5-(1,1,1,3,3-pentafluoro- propyl)oxolane (195) by Direct Fluorination.....	117
V.G Methods of Coupling Purine Bases.....	119
V.G.1 Stereochemistry of the Purine Substituted Polyfluorinated α - Haloethers.....	120
V.G.2 Deprotection of Purine Substituted Polyfluorinated α -Haloethers.....	120
V.G.2.a Deprotection of 2-Amino-6-chloropurinylmethoxy- 1,1,2,3,3,3-hexafluorobutane (205) and 2-(2-Amino-6- chloropurinyl)-5-(1,1,2,3,3,3-hexafluoropropyl)oxolane (207)	121
V.G.2.b Deprotection of 2-(6-Chloropurinyl)-5- polyfluoroalkyloxolanes.....	121
V.H Biological Test Data on Purine and Pyrimidine Substituted Polyfluorinated α -Haloethers.....	122
V.I Conclusion	122

EXPERIMENTAL SECTION..... 123

INSTRUMENTATION 124

Chapter VI

Experimental to Chapter II

VI.A The Chemistry of (Diethoxyphosphinyl)difluoromethylene Zinc Bromide (94).....	125
VI.A.1 Preparation of (Diethoxyphosphinyl)bromodifluoromethane (94)	125
VI.A.2 Preparation of (Diethoxyphosphinyl)bromodifluoromethylene Zinc Bromide (95).....	125
VI.A.3 Reactions of Benzyl Bromide	126
VI.A.3.a Reaction of Benzyl Bromide and Burton's Reagent (95).....	126
VI.A.3.b Reaction of Benzyl Bromide and Copper (I) Bromide.....	126
VI.A.3.c Reaction of Benzyl Bromide and Zinc	126
VI.A.4 Reactions of Allylic Bromides and Burton's Reagent (95).....	127
VI.A.4.a Preparation of 3-Bromocyclopentene (103)	127
VI.A.4.b Preparation of 3-Bromocyclohexene (104).....	127
VI.A.4.c Preparation of 3-Bromocycloheptene (105)	127
VI.A.4.d Reaction of 3-Bromocyclopentene (103) and Burton's Reagent (95) at -15°C	128

VI.A.4.e Reaction of 3-Bromocyclopentene (103) and Burton's Reagent (95) at 20°C.....	128
VI.A.4.f Reaction of 3-Bromocyclopentene (103) and Burton's Reagent (95) at -69°C.....	128
VI.A.4.g Reaction of 3-Bromocyclohexene (104) and Burton's Reagent (95) at -69°C.....	128
VI.A.4.h Reaction of 3-Bromocyclohexene (104) and Burton's Reagent (95) at 86°C.....	129
VI.A.4.i Reaction of 3-Bromocycloheptene (105) and Burton's Reagent (95) at -69°C.....	129
VI.A.4.j Reaction of 3-Bromocycloheptene (105) and Burton's Reagent (95) at 86°C.....	129
VI.A.5 Attempted Palladium (0) Catalysed Reactions of Burton's Reagent with Allylic Acetates and Phenyl Allyl Ethers	130
VI.A.5.a Preparation of Cyclohex-3-ene carboxylic acid.....	130
VI.A.5.b The Synthesis of 1-Iodo-6-oxa-bicyclo[3.2.1]octan-5-one	130
VI.A.5.c The Synthesis of 6-Oxa-bicyclo[3.2.1]octen-5-one (113) Method A.....	130
VI.A.5.d The Synthesis of 6-Oxa-bicyclo[3.2.1]octen-5-one (113) Method B.....	131
VI.A.5.e The Synthesis of <i>cis</i> -3-Hydroxy-5-carbomethoxy-1-cyclohexene.....	131
VI.A.5.f The Synthesis of <i>cis</i> -3-Acetoxy-5-carbomethoxy-1-cyclohexene (112).....	131
VI.A.5.g The Attempted Reaction of <i>cis</i> -3-Acetoxy-5-carbomethoxy-1-cyclohexene (112) with Burton's Reagent (95).....	132
VI.A.5.h The Synthesis of Cyclopentadiene	132
VI.A.5.i The Synthesis of 3-Chlorocyclopentene.....	132
VI.A.5.j The Synthesis of 3-Phenoxycyclopentene (114).....	132
VI.A.5.k The Attempted Reaction of 3-Phenoxycyclopentene (114) and Burton's Reagent (95)	133
VI.A.5.l The Attempted Reaction of 6-oxabicyclo[3.2.1]octen-5-one (113) and Burton's Reagent (95)	133
VI.B The Chemistry of (Diethoxyphosphinyl)difluoromethylene Lithium.....	133
VI.B.1 Synthesis of (Diethoxyphosphinyl)difluoromethane (102)	133
VI.B.2 Preparation of (Diethoxyphosphinyl)difluoromethylene Lithium (96).....	134
VI.B.3 Reaction of (Diethoxyphosphinyl)difluoromethylene Lithium (96) and Deuterium Oxide	134
VI.B.4 Reaction of (Diethoxyphosphinyl)difluoromethylene Lithium (96) with Alkyl Halides	134
VI.B.4.a Reaction of (Diethoxyphosphinyl)difluoromethylene Lithium (96) and Methyl Iodide.....	134
VI.B.4.b Reaction of (Diethoxyphosphinyl)difluoromethylene Lithium (96) and Ethyl Iodide.....	135
VI.B.4.c The Reaction of (Diethoxyphosphinyl)difluoromethylene Lithium (96) and 4-Nitrophenylethane Bromide.....	135
VI.B.4.d The Reaction of (Diethoxyphosphinyl)difluoromethylene Lithium (96) and 2-Bromopropane.....	135
VI.B.4.e The Reaction of (Diethoxyphosphinyl)difluoromethylene Lithium (96) and Cyclobutyl Bromide	135
VI.B.5 Reaction of Benzylic and Allylic Halides with (Diethoxyphosphinyl)difluoromethylene Lithium (96).....	135
VI.B.5.a The Reaction of (Diethoxyphosphinyl)difluoromethylene Lithium (96) and 1-Bromoethylbenzene	136
VI.B.5.b The Reaction of (Diethoxyphosphinyl)difluoromethylene Lithium (96) and Allyl Bromide	136
VI.B.5.c The Reaction of (Diethoxyphosphinyl)difluoromethylene Lithium (96) and 3-Bromocyclopentene (103).....	136

VI.B.5.d The Reaction of (Diethoxyphosphinyl)difluoromethylene Lithium (96) and 3-Bromocyclohexene (104).....	136
VI.B.5.e The Reaction of (Diethoxyphosphinyl)difluoromethylene Lithium (96) and Bromine.....	137
VI.B.6 The Reaction of (Diethoxyphosphinyl)difluoromethylene Lithium (96) with Diacetone-D-glucose (123), a Sugar Model.....	137
VI.B.6.a Preparation of 1,2:5,6-Di- <i>O</i> -isopropylidene-3- <i>O</i> -toluene- <i>p</i> -sulphonyl- α -D- <i>glucofuranose</i> (124).....	137
VI.B.6.b Preparation of 1,2:5,6-Di- <i>O</i> -isopropylidene-3- <i>O</i> -triflic- α -D- <i>glucofuranose</i> (125).....	137
VI.B.6.c Attempted Reaction of (Diethoxyphosphinyl)difluoromethylene Lithium (96) and 1,2:5,6-Di- <i>O</i> -isopropylidene-3- <i>O</i> -toluene- <i>p</i> -sulphonyl- α -D- <i>glucofuranose</i> (124).....	138
VI.B.6.d Attempted Reaction of (Diethoxyphosphinyl)difluoromethylene Lithium (96) and 1,2:5,6-Di- <i>O</i> -isopropylidene-3- <i>O</i> -triflic- α -D- <i>glucofuranose</i> (125).....	138
VI.B.7 Reaction of (Diethoxyphosphinyl)difluoromethylene Lithium (96) on Epoxides.....	138
VI.B.7.a The Reaction of (Diethoxyphosphinyl)difluoromethylene Lithium (96) and Oxirane.....	138
VI.C. Reactions of 3-[(Diethoxyphosphinyl)difluoromethyl]cyclohexene (107).....	138
VI.C.1 The Synthesis of 1-[(Diethoxyphosphinyl)difluoromethyl]-2,3-epoxycyclohexene (127).....	138
VI.C.1.a The Reaction of Magnesium monoperoxyphthalate and 3-[(Diethoxyphosphinyl)difluoromethyl]cyclohexene (107).....	139
VI.C.1.b The Reaction of Calcium Oxychloride and 3-[(Diethoxyphosphinyl)difluoromethyl]cyclohexene (107).....	139
VI.C.1.c The Reaction of 3-Chloroperbenzoic acid and 3-[(Diethoxyphosphinyl)difluoromethyl]cyclohexene (107).....	139
VI.C.2 The Reaction of DAST and 1-[(Diethoxyphosphinyl)-difluoromethyl]-2,3-epoxycyclohexene (127).....	139
VI.C.3 The Reaction of Osmium Tetroxide and 3-[(Diethoxyphosphinyl)-difluoromethyl]cyclohexene (107).....	140
VI.C.3 The Reaction of Silver Acetate/Water and 3-[(Diethoxyphosphinyl)difluoromethyl]cyclohexene (107).....	140

Chapter VII

Experimental to Chapter III

VII.A The Reaction of 3-[(Diethoxyphosphinyl)difluoromethyl]cyclohexene (107) and Selenium Dioxide.....	141
VII.B The Reaction of 3-[(Diethoxyphosphinyl)difluoromethyl]cyclohexene (107) and <i>N</i> -Bromosuccinimide.....	141
VII.C The Reaction of 3-Bromo-6-[(diethoxyphosphinyl)difluoromethyl]-cyclohexene (142) and 6-Chloropurine (144).....	142
VII.D The Attempted Synthesis of 3-(<i>N</i> 9-Adenyl)-6-[(diethoxyphosphinyl)-difluoromethyl]cyclohexene (147).....	142
VII.D.1 The Reaction of 3-[<i>N</i> 9-(6-Chloropurinyl)]-6-[(diethoxyphosphinyl)difluoromethyl]cyclohexene (145) and Sodium Azide.....	142
VII.D.2 The Reaction of 3-[<i>N</i> 9-(6-Azidopurinyl)]-6-[(diethoxyphosphinyl)difluoromethyl]cyclohexene and Triphenylphosphine.....	142
VII.D.3 The Reaction of 3-[<i>N</i> 9-(6-Chloropurinyl)]-6-[(diethoxyphosphinyl)difluoromethyl]cyclohexene (145) and Sodium Amide.....	143
VII.D.4 The Reaction of 3-[<i>N</i> 9-(6-Chloropurinyl)]-6-[(diethoxyphosphinyl)difluoromethyl]cyclohexene (145) and Liquid Ammonia.....	143
VII.D.5 The Reaction of 3-[<i>N</i> 9-(6-Chloropurinyl)]-6-[(diethoxyphosphinyl)difluoromethyl]cyclohexene (145) and Alcoholic Ammonia Solution.....	143

VII.D.6 The Reaction of 3-[<i>N</i> 9-(6-Chloropurinyl)]-6-[(diethoxyphosphinyl)difluoromethyl]cyclohexene (145) and Silver (I) Fluoride.....	143
VII.D.7 The Reaction of 3-[<i>N</i> 9-(6-Chloropurinyl)]-6-[(diethoxyphosphinyl)difluoromethyl]cyclohexene (145) and Silver (II) Fluoride.....	144
VII.D.8 The Reaction of 3-[<i>N</i> 9-(6-Chloropurinyl)]-6-[(diethoxyphosphinyl)difluoromethyl]cyclohexene (145) and Aqueous Ammonia/Dioxan Solution.....	144
VII.E The Reaction of 3-(<i>N</i> 9-Adenyl)-6-[(diethoxyoxyphosphinyl)difluoromethyl]cyclohexene (147) and Trimethylsilyl Bromide	144
VII.F The Reaction of 3-Bromo-6-[(diethoxyphosphinyl)difluoromethyl]-cyclohexene (142) and 2-Amino-6-chloropurine (148)	145
VII.G The Reaction of 3-[(Diethoxyphosphinyl)difluoromethyl]-6-(<i>N</i> 9-guanyl)cyclohexene (149) and Aqueous Hydrochloric Acid.....	145
VII.H The Reaction of 3-[(Ethoxyhydroxyphosphinyl)difluoromethyl]-6-(<i>N</i> 9-guanyl)cyclohexene (151) and Trimethylsilyl Bromide.....	145

Chapter VIII

Experimental to Chapter IV

VII.A General Method to Charge a Carius Tube	146
VII.B Utilising Gamma-ray Irradiation.....	146
VIII.B.1 The Reaction of (Diethoxyphosphinyl)bromodifluoromethane (94) and Cyclohexene.....	146
VIII.B.2 The Synthesis of [Bis(trimethylsiloxy)phosphinyl]bromodifluoromethane (155).....	146
VIII.B.3 The Synthesis of (Dihydroxyphosphinyl)bromodifluoromethane (154)	147
VIII.B.4 The Reaction of (Dihydroxyphosphinyl)bromodifluoromethane (154) and Cyclohexene	147
VIII.C Utilising U.V. Irradiation	147
VIII.C.1 The Reaction of (Diethoxyphosphinyl)bromodifluoromethane (94) and Cyclohexene.....	147
VIII.C.2 The Reaction of (Diethoxyphosphinyl)bromodifluoromethane (94), Cyclohexene and Benzophenone.....	148
VIII.C.3 The Synthesis of (Diethoxyphosphinyl)difluoroiodomethane (118)	148
VIII.C.4 The Reaction of (Diethoxyphosphinyl)difluoroiodomethane (118) and Cyclohexene	148
VIII.C.5 The Reaction of (Diethoxyphosphinyl)difluoroiodomethane (118) and Cyclopentene	149
VIII.C.6 The Reaction of (Diethoxyphosphinyl)difluoroiodomethane (118) and Cycloheptene	149
VIII.C.7 The Reaction of (Diethoxyphosphinyl)difluoroiodomethane (118) and 2,3-Dihydrofuran	149
VIII.C.8 The Reaction of (Diethoxyphosphinyl)difluoroiodomethane (118) and 3,4-Dihydrofuran	150
VIII.C.9 The Reaction of (Diethoxyphosphinyl)difluoroiodomethane (118) and Furan	150
VIII.D SET Reactions	150
VIII.D.1 The Attempted Reaction of (Diethoxyphosphinyl)bromodifluoromethane (94) and Cyclohexene utilising Copper Catalysis	150
VIII.D.2 The Attempted Reaction of (Diethoxyphosphinyl)bromodifluoromethane (94) and Cyclohexene utilising Samarium Diiodide.....	150
VIII.D.3 The Attempted Reaction of (Diethoxyphosphinyl)difluoroiodomethane (118) and Cyclohexene utilising Samarium Diiodide.....	151

Chapter IX**Experimental to Chapter V**

IX.A General Procedure for the Synthesis of Fluorinated Ethers.....	152
IX.B Synthesis of Acyclic Fluoroethers	152
IX.B.1 Synthesis of Methoxy-2,2,3,4,4,4-hexafluorobutane (173)	152
IX.B.2 Synthesis of 1-Methoxy-2,2,4,4,4-pentafluorobutane (174).....	152
IX.B.3 Attempted Synthesis of 1-Methoxy-4,4,4-trifluorobutane (175).....	152
IX.B.4 Competition Reactions	153
IX.B.4.a Competition of 3,3,3-Trifluoropropene and Hexafluoropropene for Methoxymethane	153
IX.B.4.b Competition of 1,1,3,3,3-Pentafluoropropene and Hexafluoropropene for Methoxymethane	153
IX.B.4.c Competition of 3,3,3-Trifluoropropene and 1,1,3,3,3- Pentafluoropropene for Methoxymethane.....	153
IX.C Synthesis of Cyclic Fluoroethers.....	153
IX.C.1 Synthesis of 2-(1,1,2,3,3,3-Hexafluoropropyl)oxolane (176)	154
IX.C.2 Synthesis of 2-(1,1,3,3,3-Pentafluoropropyl)oxolane (177).....	154
IX.C.3 Synthesis of 2-(2-Chloro-1,1,2-trifluoroethyl)oxolane (178).....	154
IX.D Halogenation of Fluorinated Ethers.....	155
IX.D.1 Synthesis of 1-Chloromethoxy-2,2,3,4,4,4-hexafluorobutane (185)	155
IX.D.2 Synthesis of 2-Chloro-5-(1,1,2,3,3,3-hexafluoropropyl)oxolane (186)	155
IX.D.3 Synthesis of 2-Chloro-5-(1,1,3,3,3-pentafluoropropyl)oxolane (187)	155
IX.D.4 Synthesis of 2-Chloro-5-(2-chloro-1,1,2-trifluoroethyl)oxolane (188)	155
IX.D.5 The Reaction of 2-Chloro-5-(1,1,2,3,3,3-hexafluoropropyl)- oxolane (176) and Sodium Hydroxide.....	156
IX.E.The Coupling of Nucleoside Bases to Polyfluorinated α -Haloethers.....	156
IX.E.1 Silylation of Pyrimidine Bases	156
IX.E.1.a Silylation of Uracil (190)	156
IX.E.1.b Silylation of 5-Fluorouracil (191)	156
IX.E.2 General Procedure for Coupling of Pyrimidine Bases	156
IX.E.2.a Reaction of 2-Chloro-5-(2-chloro-1,1,2-trifluoroethyl)- oxolane (188) and 1,3-Disilyloxypyrimidine (190)	157
IX.E.2.b Reaction of 2-Chloro-5-(2-chloro-1,1,2-trifluoroethyl)- oxolane (188) and 5-Fluoro-1,3-disilyloxypyrimidine (191)	157
IX.E.2.c Reaction of 2-Chloro-5-(1,1,3,3,3-pentafluoropropyl)- oxolane (187) and 1,3-Disilyloxypyrimidine (190)	157
IX.E.2.d Reaction of 2-Chloro-5-(1,1,3,3,3-pentafluoropropyl)- oxolane (187) and 5-Fluoro-1,3-disilyloxypyrimidine (191)	157
IX.E.2.e Reaction of 2-Chloro-5-(1,1,2,3,3,3-hexafluoropropyl)- oxolane (186) and 1,3-Disilyloxypyrimidine (190)	157
IX.E.2.f Reaction of 2-Chloro-5-(1,1,2,3,3,3-hexafluoropropyl)- oxolane (186) and 5-Fluoro-1,3-disilyloxypyrimidine (191)	158
IX.E.2.g Reaction of 1-Chloromethoxy-2,2,3,4,4,4-hexafluoro- butane (185) and 1,3-Disilyloxypyrimidine (190).....	158
IX.E.2.h Reaction of 1-Chloromethoxy-2,2,3,4,4,4-hexafluoro- butane (185) and 5-Fluoro-1,3-disilyloxypyrimidine (191).....	158
IX.E.3 Reaction of 2-Chloro-5-(1,1,2,3,3,3-hexafluoropropyl)oxolane (186) and 1,3-Disilyloxypyrimidine (190) with Tin (IV) Chloride.....	158
IX.E.4 General Procedure for Coupling Purine Bases.....	159
IX.E.4.a Reaction of 1-Chloromethoxy-2,2,3,4,4,4-hexafluoro- butane (185) and 2-Amino-6-chloropurine (144).....	159
IX.E.4.b Reaction of 2-Chloro-5-(1,1,2,3,3,3-hexafluoropropyl)- oxolane (186) and 6-Chloropurine (144)	159

IX.E.4.c Reaction of 2-Chloro-5-(1,1,2,3,3,3-hexafluoropropyl)-oxolane (186) and 2-Amino-6-chloropurine (148)	159
IX.E.4.d Reaction of 2-Chloro-5-(1,1,3,3,3-pentafluoropropyl)-oxolane (187) and 6-Chloropurine (144)	160
IX.E.4.e Reaction of 2-Chloro-5-(2-chloro-1,1,2-trifluoroethyl)-oxolane (188) and 6-Chloropurine (144)	160
IX.E.5 Deprotection of 2-Amino-6-chloropurinyl Derivatives	160
IX.E.5.a To 2-(1,1,2,3,3,3-Hexafluoropropyl)-5-(guanyl)oxolane (210)	160
IX.E.5.b To 1-Guanylmethoxy-2,2,3,4,4,4-hexafluorobutane (211)	161
IX.E.6 General Method for the Deprotection of 2-(6-Chloropurinyl)-5-polyfluoroalkylethers	161
IX.E.6.a To 2-Adenyl-5-(1,1,2,3,3,3-hexafluoropropyl)oxolane (212)	161
IX.E.6.b To 2-Adenyl-5-(1,1,3,3,3-pentafluoropropyl)oxolane (213)	161
IX.E.6.c To 2-Adenyl-5-(2-chloro-1,1,2-trifluoroethyl)oxolane (214)	161
IX.F The Direct Fluorination of 1-(Uracyl)-4-(1,1,1,3,3-pentafluoropropyl)-oxolane (194)	162
IX.F.1 The Dehydration of 1-(5-Fluoro-5,6-dihydro-6-hydroxyuracyl)-4-(1,1,1,3,3-pentafluoropropyl)oxolane (202)	162

APPENDICES

<u>Appendix One</u> <u>NMR Spectra</u>	163
<u>Appendix Two</u> <u>Infra Red Spectra</u>	250
<u>Appendix Three</u> <u>Mass Spectra</u>	262
<u>Appendix Four</u> <u>Colloquia and Conferences Attended</u>	309
<u>REFERENCES</u>	317

CHAPTER ONE

FLUORINATED NUCLEOSIDES AND NUCLEOTIDE ANALOGUES

I.A General Introduction

As the thirteenth most abundant element in the Earth's crust,¹ surprisingly, fluorine is found in very few natural products, *e.g.* potassium monofluoroacetate present in the South African Gifblaar plant (*Dichapetalam cymosum*) and more than thirty other tropical plants in South America, Africa and Australia,² ω -fluorooleic acid³ and ω -fluoropalmitic acid⁴ found in the shrub ratsbane (*Dichapetalam toxicarium*), and nucleocidin,⁵ an antibiotic isolated from *Streptomyces calvus*. Most organofluorine compounds are therefore 'unnatural', *i.e.* man made moieties, and the introduction of fluorine into organic molecules has spawned a large number of compounds with a wide and varied application.⁶⁻⁹

Fluorinated compounds can be generally divided into highly fluorinated derivatives, *i.e.* where all or most of the carbon to hydrogen bonds are replaced by fluorine, or lightly fluorinated compounds. These two broad groups generally find quite different application.

Highly fluorinated saturated compounds are used as coolants,¹⁰ fire extinguishers,¹¹ anaesthetics,¹² polymers^{13,14} and blood substitutes,^{15,16} the prerequisite in their applications being the chemical inertness of the compounds. Inertness of such compounds can be attributed mostly to the strength of the carbon to fluorine bond; which at 485kJmol⁻¹ is the strongest single covalent bond to carbon.¹⁷

Lightly fluorinated compounds have become extremely important to the pharmaceutical industry, where a certain similarity must exist between the biologically active substrate and the modified derivative. To this end lightly fluorinated materials have found uses as antitumour,¹⁸ antifungal¹⁹ and antiviral agents²⁰ as well as biological tools for probing²¹ and NMR imaging.²²⁻²⁴

It is these lightly fluorinated compounds which will be discussed in this thesis with specific reference to nucleoside and nucleotide analogues.

I.B Fluorine in Biological Systems

The chemical alteration of biologically active compounds, for use as potential antimetabolites, is very well established.^{25,26} Modification, by the introduction of halogen atoms is of particular interest, in that, enhancement of biological activity is often observed, *e.g.* the highly potent pesticide decamethrin (**1**),²⁷ based on the natural occurring pyrethroid pesticides isolated from chrysanthemums, or the important class of



compounds, the fluorosteroids, *e.g.* 6- α -fluoroprogesteron (2),²⁸ which is ten times more reactive than the natural hormone progesterone.

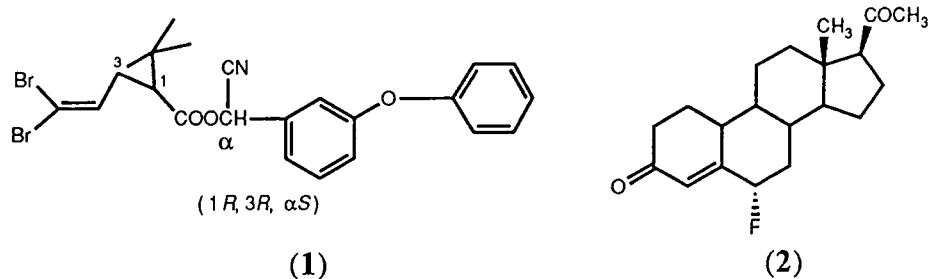

As new reagents, and improved techniques, for the selective introduction of fluorine and polyfluoroalkyl/alkenyl groups become available,^{29,30} fluorine containing pharmaceuticals and agrochemicals have achieved an increased prominence in modern bioorganic chemistry, due to their unique physiological effects and properties, these are outlined below.

I.B.1 Fluorine as a Hydrogen Substitute

The most sterically similar monovalent element to hydrogen is the fluorine atom (the Van Der Waals' radius of fluorine: 1.35Å; of hydrogen: 1.1Å).³¹ Thus, in most instances, the substitution of hydrogen by fluorine in an organic substrate causes little or no perturbation of the geometry; and generally a fluorinated analogue will bind at an enzymic site with comparable affinity. Once bound the substrate can:

i) be turned over by the biological system, to give an unnatural product containing fluorine, *i.e.* mimic the natural substrate; *e.g.* the hydrolysis of the prochiral ester diethyl-2-fluoro-2-methylmalonate by Lipase-MY from the yeast *Candida cylindracea* in 91% enantiomeric excess.³²

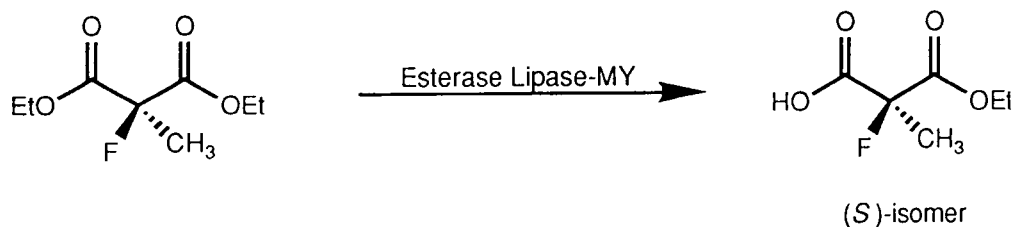

or

ii) inhibit the enzyme, stopping key biological processes *e.g.* the use of monofluoroacetate by the Gifblaar plant as a defensive mechanism, where monofluoroacetate blocks the Krebs cycle and inhibits citrate transport;³³ or compound (3) which inhibits acetyl-cholinesterase, a neurotransmitter.³⁴ These are termed 'lethal syntheses' because the modified substrate binds irreversibly to the enzyme active site precipitating the death of the cell and ultimately the organism.

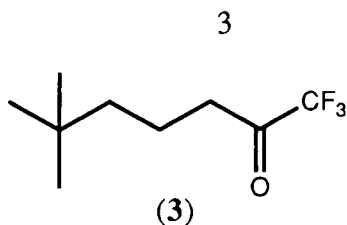

The mode of action of the enzyme on the substrate depends on whether the mimicking fluorine atoms are directly involved in electrostatic interactions or chemical processes at the active site. Given that either or both the afore mentioned facts are the case, inhibition may occur due to the dramatic differences in the strength and electronic properties associated with the carbon-fluorine and carbon-hydrogen bonds.

	Fluorine	Hydrogen
Average bond strength to carbon ¹⁷ (kJmol ⁻¹)	485	413
Electronegativity on Pauling scale ³¹ (carbon: 2.55)	3.98	2.20

I.B.2 Fluorine as an Oxygen Mimic

The high electronegativity of fluorine means it can be used to mimic oxygen in many biological systems^{35,36} due to :

- i) The polar effect of a fluorine atom being similar to that of a hydroxyl group;
- ii) three lone pairs available on a fluorine atom mean it can act as a Lewis base in hydrogen bonding, though not a donor *cf.* the hydroxyl group;

iii) the difluoromethylene group can be considered to be isosteric with the oxygen moiety. The bond angle C-CF₂-P in 1,1-difluoro-2-aminoethylphosphonic acid (4) is very similar to that of the corresponding phosphate C-O-P angle , at 116.5° for the former and 118.7° in the latter, compared to 112.1° for C-CH₂-P in 2-aminoethylphosphonate.³⁷ Other evidence for the isosteric nature of the difluoromethylene unit is that the (dihydroxyphosphinyl)difluoromethylene group is capable of being metabolised in enzymic systems *e.g.* NADH linked glycerol-3-phosphate dehydrogenase;³⁶

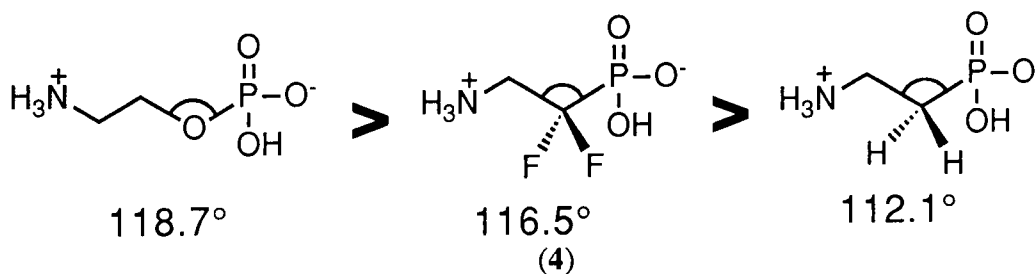

iv) the effect on charge distribution of the two groups is similar, which can be judged by the second acid dissociation constants of the substituted phosphate anions (figure 1.1).³⁸

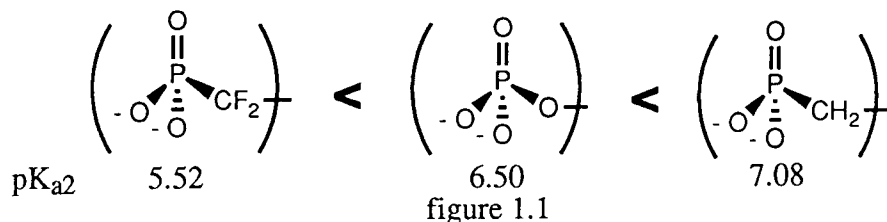

I.B.3 Fluorine in Transport Mechanisms

The introduction of fluorine or a small perfluoroalkyl/alkenyl group, R_F , into an organic molecule is highly desirable in connection with biological studies. This is due to the high lipophilic nature of the R_F group,³⁹ which can favour increased *in vivo* transport, and absorption rate of a drug across a lipid membrane. This is used to greatest effect in the agrochemical industry, with the almost routine introduction of a trifluoromethyl group.

I.C Fluorine Containing Nucleosides

I.C.1 Introduction

Fluoronucleosides constitute a group of synthetic compounds useful as potential antiviral agents⁴⁰ *i.e.* they can directly inhibit virally encoded enzymes without a major effect on cellular metabolism; to this end fluorine has been selectively substituted into a number of sites in naturally occurring nucleosides (figure 1.2) with the hope of preventing viral nucleic acid replication *in vivo*.

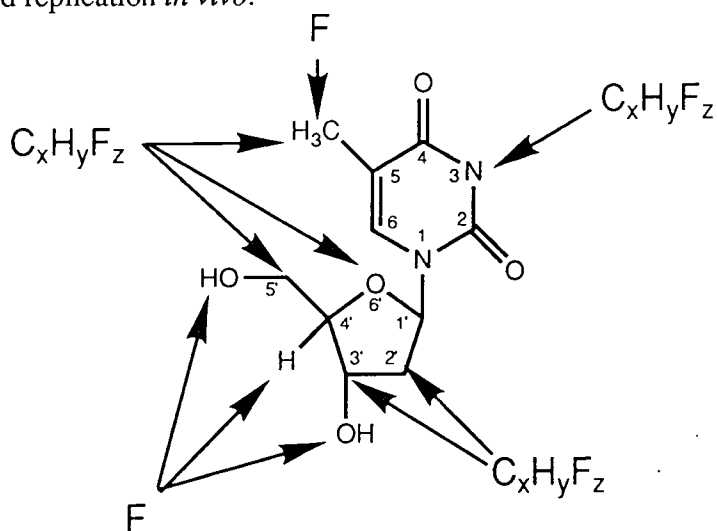
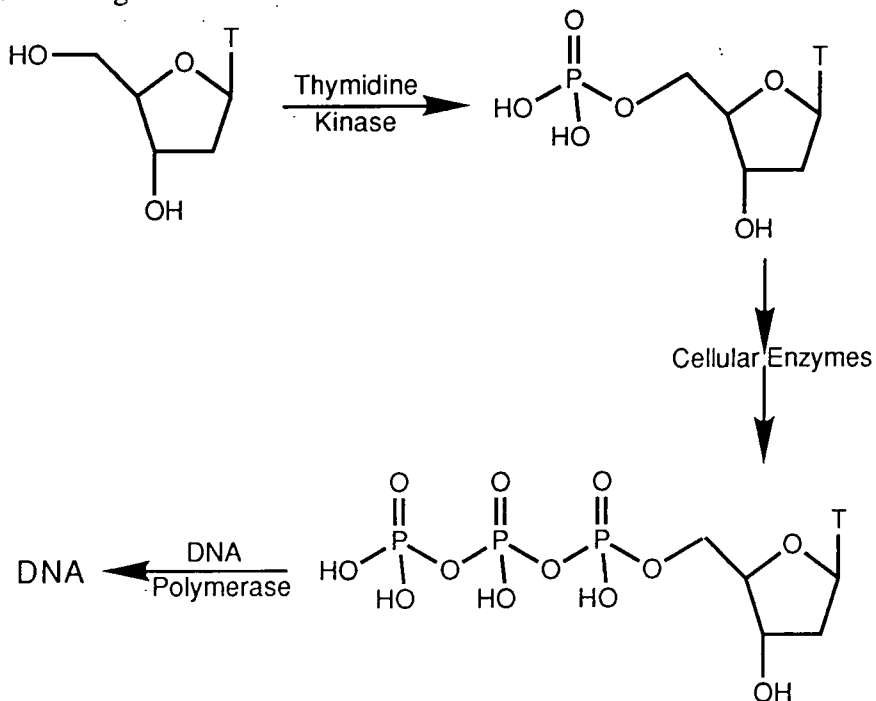

figure 1.2

To gain an insight into the physiological mode of action of the nucleoside analogues it is important to understand the cellular cycle for DNA or RNA synthesis from the nucleoside pool; scheme 1.1 illustrates the biosynthesis of deoxythymidine triphosphate by repeated phosphorylation, which can then be incorporated into DNA by the enzyme DNA polymerase. It is at the last step that most antiviral agents discussed in this section are targeted.⁴¹



scheme 1.1

I.C.2 Base Modified Derivatives

The advent of the potent antitumour drug 5-fluorouracil⁴² in the 1950s for the treatment of bowel cancer, leukaemia and Hodgkin's disease demonstrated the potential of introducing fluorine into a nucleic acid base. From this starting point selective fluorination of bases attached to nucleosides began.

I.C.2.a Pyrimidines

I.C.2.a.(i) Modification at C5 in the Ring

In 1959 iododeoxyuridine (5)⁴³ and later 5-trifluoromethyldeoxyuridine (6),⁴⁴ originally synthesised as potential antitumour agents, were found, in the form of their triphosphates, to inhibit viral DNA polymerase. They were non-specific in their action, with a problem therefore of high toxicity, however, despite this they were used clinically against herpes infections.⁴⁵

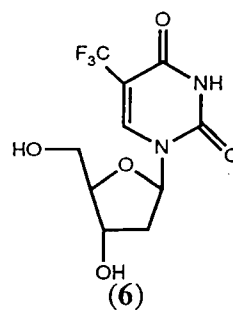
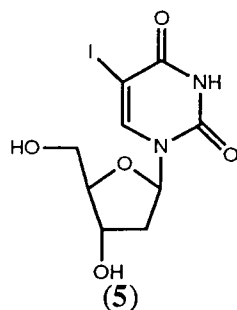

The fluoronucleoside (6) was synthesised from the acetyl protected derivative of (5), however, the difluoro- and monofluoro-methyl analogues were prepared *via* halogen exchange on the thymidine methyl group⁴⁶ (scheme 1.2); these analogues of (6) showed falling activity, the monofluoromethyl derivative possessing negligible antiviral activity.

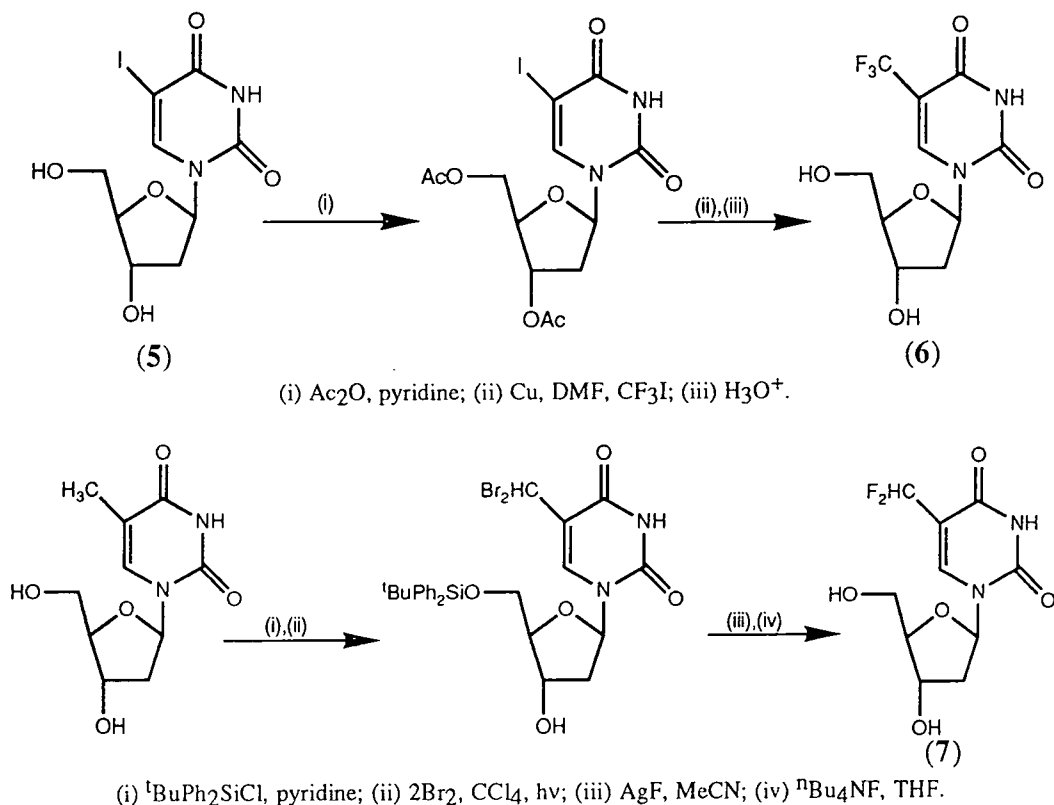

scheme 1.2

A significant discovery followed when it was observed that replacement of the thymidine methyl group with a larger carbon chain led to greater efficacy against herpes simplex virus 1 (HSV1).⁴¹ The increase in activity came from a greater substrate specificity of the analogues towards virally encoded thymidine kinase (TK),⁴² in so doing the mono- and diphosphate concentration of the antiviral agent increased over that of the natural nucleotides in infected cells.

1970 saw the synthesis of the (*E*)-5-bromovinyl analogue BVDU (8)⁴⁷ the most active of the C5 substituted thymidines. Fluorinated side chains have also been investigated, however, their efficacy was shown to be much lower (table 1.1).

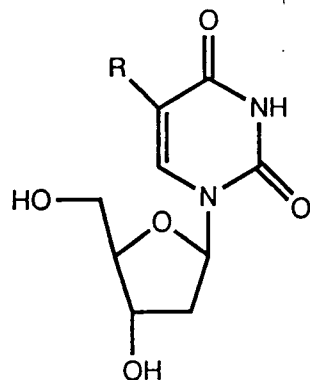

Compound	R	HSV-1 activity	HSV-2 activity
6	CF ₃	√√√	√√
7	CHF ₂	√√√	√√√
8	(E)-CH=CHBr	√√√√√	√√
9	CH ₂ F	Inactive	Inactive
10a	(E)-CH=CHF	√√√	√√√
10b	(Z)-CH=CHF	Inactive	Inactive
11	(E)-CH=CHCF ₃	√√√√	√√
12	CF=CFCF ₃	Inactive	Inactive
13		Inactive	Inactive
14		Inactive	Inactive
15	CF ₂ CF ₃	√	√

√ = indicates relative measure of potency
table 1.1

Compounds (12)-(14) were synthesised by Coe *et al.*⁴⁸ by the reaction of (5) with butyllithium, followed by subsequent electrophilic attack of a polyfluoroolefin, (scheme 1.3);

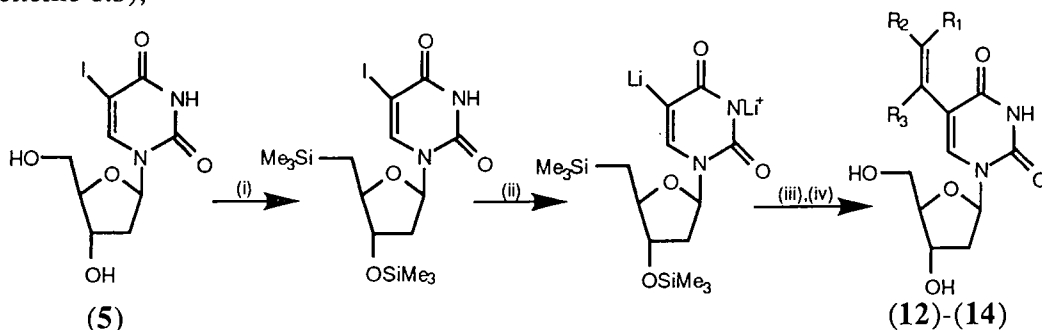

(i) (Me₃SiN)₂H, (NH₄)₂SO₄, Δ; (ii) ⁿBuLi; (iii) Fluoroalkene; (iv) H₃O⁺.

R₁ = F, CF₃; R₂ = R₃ = F, H, -(CF₂)₃-, -(CF₂)₄-

scheme 1.3

while the methodology for the attachment of fluoroalkyl substituents at C5, *e.g.* compound (15), was achieved by the use of fluoroalkyl mercury reagents⁴⁹ (scheme 1.4).

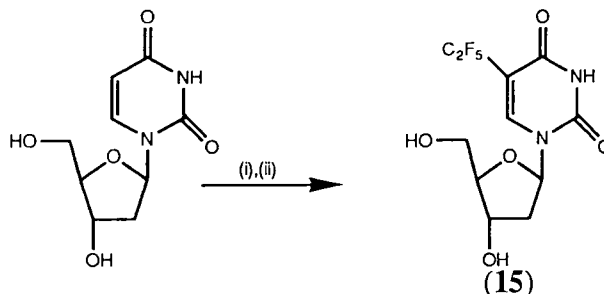

(i) 2,2'-azobisisobutyronitrile; (ii) (C₂F₅)₂Hg

scheme 1.4

It can be seen from table 1.1 that activity is dependant on a number of factors,⁵⁰ although, these are not clearly understood. However, the number of vinylic hydrogens is important; activity drops in the polyfluoroalkenyl series with increased halogen substitution. Similarly, geometric isomers of the same group also show wide variation in inhibiting DNA polymerase; (*Z*)-isomers showing little or no action.⁵¹ The crystal structure⁵² of (*E*)-BVDU (**8**) indicates a structure (figure 1.3) with the bromovinylic hydrogen bonding to the 4-oxygen, which may allow the nucleoside to fit ideally within the catalytic site of the viral TK. This hydrogen bond would be absent in the (*Z*)-isomers and higher halogenated moieties.

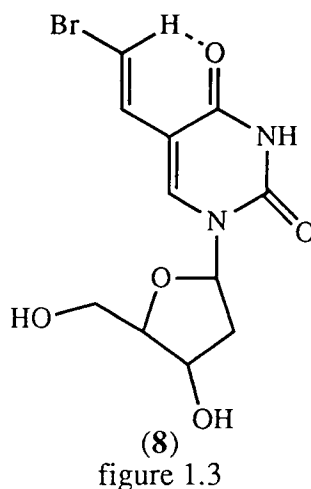

I.C.2.a.(ii) Modification at O4 Position

German workers⁵³ have successfully modified the C4 keto group of thymidine and uracil derivatives by its conversion into a difluoromethylene ether. The thermolysis of bis(trifluoromethyl) mercury yields difluorocarbene which with suitable protection and activation of the nucleosides yields a range of difluoromethylene ethers (scheme 1.5). The mode of action of these compounds *in vivo* is as yet uncertain, though some of the analogues show significant inhibition of DNA polymerase.

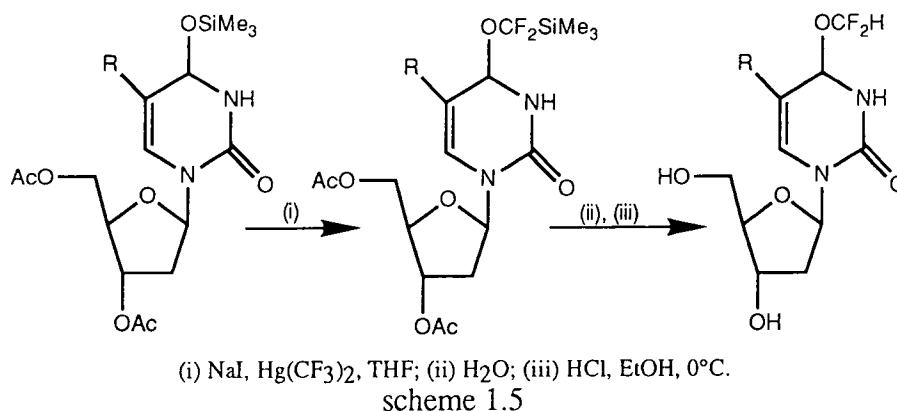

I.C.2.a.(iii) Modification at N3 in the Ring

The deliberate substitution of the N3 nitrogen in cytidine led M^cNamara and Cook⁵⁴ to a potent anticancer agent (scheme 1.6).

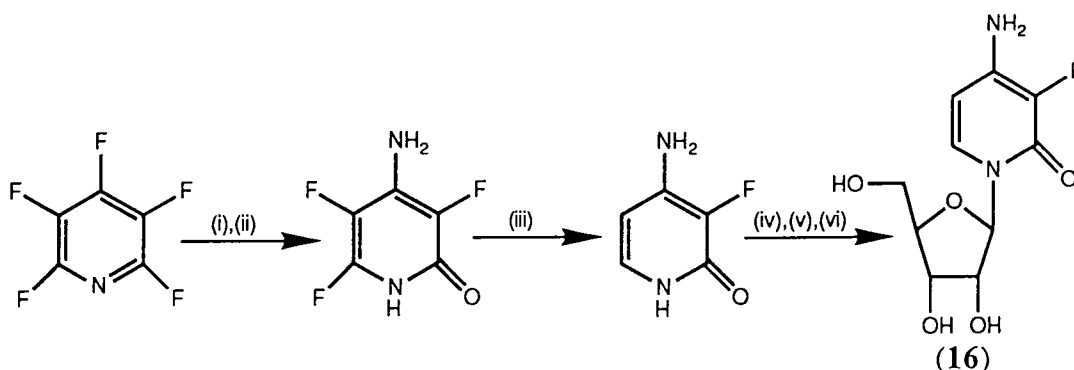

(i) NH_3 ; (ii) NaOH ; (iii) N_2H_4 , EtOH , Δ ; (iv) $(\text{Me}_3\text{SiN})_2\text{H}$; $(\text{NH}_4)_2\text{SO}_4$; (v) SnCl_4 , 1-chloro-tri-O-benzyl-furanose; (vi) NaOCH_3 , MeOH .

scheme 1.6

The 3-fluoropyridone nucleoside (**16**) was synthesised by nucleophilic aromatic substitution on pentafluoropyridine in an overall yield of 12% and, although, the cytostatic properties and efficacy of the nucleoside were found to be excellent, again a definitive reason for activity is unclear, and may be due to the CF bond acting as an isostere and isopolar group for nitrogen.

I.C.2.b Purines

I.C.2.b.(i) Modification at C2 in the ring

Modification at the C2 position of purine derivatives with fluorine containing moieties came to the fore when Montgomery and co-workers⁵⁵ found that 2-fluoroadenosine (**17**) and its sugar modified congeners were cytostatic, with resistance towards deamination by the catabolic enzyme adenosine deaminase and thus potential anticancer agents. This enzyme is responsible for conversion of the nucleic acid residue adenine to inosine *in vivo*; consequently depleting the bioavailability of any adenine based antiviral agent. To this end a number of routes to introduce fluorine containing moieties at C2 have arisen.

Robins and Uznanski⁵⁶ developed a high yielding route into 2-fluoroadenosine derivatives by non-aqueous diazotisation (scheme 1.7), overcoming hydrolysis of the glycosidic linkage found in previous routes^{55,57} utilising diazotisation in strongly acidic media.

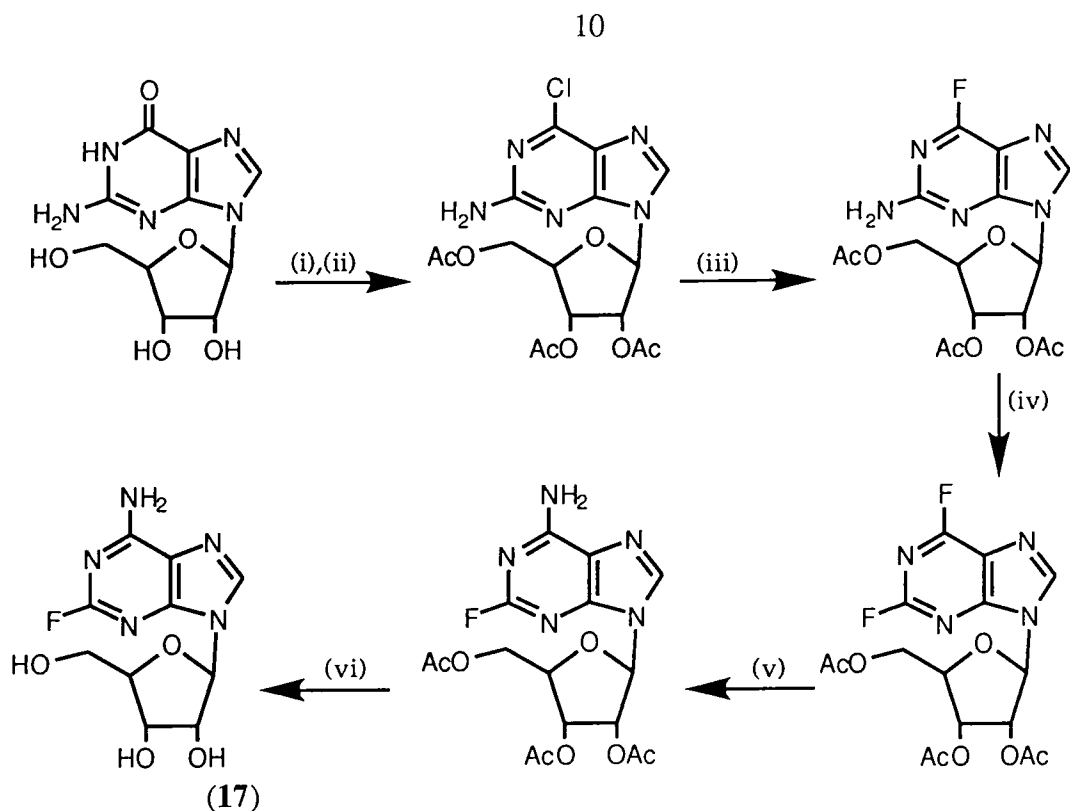

(i) Ac_2O , pyridine, DMF; (ii) POCl_3 , PhNMe_2 , Et_4NCl , MeCN; (iii) KF , Me_3N , DMF; (iv) $^t\text{BuNO}_2$, HF, pyridine; (v) NH_3 , $(\text{CH}_2\text{OCH}_3)_2$; (vi) EtOH, NH_3 .

scheme 1.7

Transglycolization⁵⁸ has also been used to convert more easily accessible pyrimidine nucleosides into the C2 fluoropurine equivalents, Matthes *et al.*⁵⁹ coupling 1-(5'-O-acetyl-2',3'-dideoxy-3'-fluoro- β -D-ribofuranosyl) thymine with 2-fluoroadenine to give compound (18). This compound together with other 3'-fluorosugars cited showed negligible cytotoxicity and high efficacy in inhibiting the enzyme reverse transcriptase (RT).

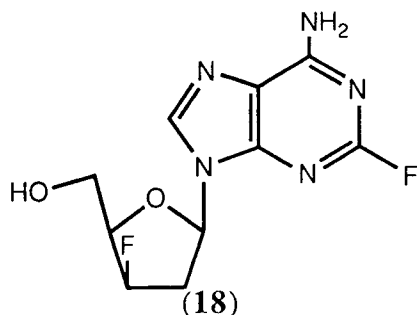

Organometallic reagents have also been used to introduce the trifluoromethyl group into 2',3'-dideoxyadenosine (19) at the C2 position to give compound (20), Nair and Buenger⁶⁰ synthesising a series of 2-substituted analogues from 2-iodoadenosine (21).

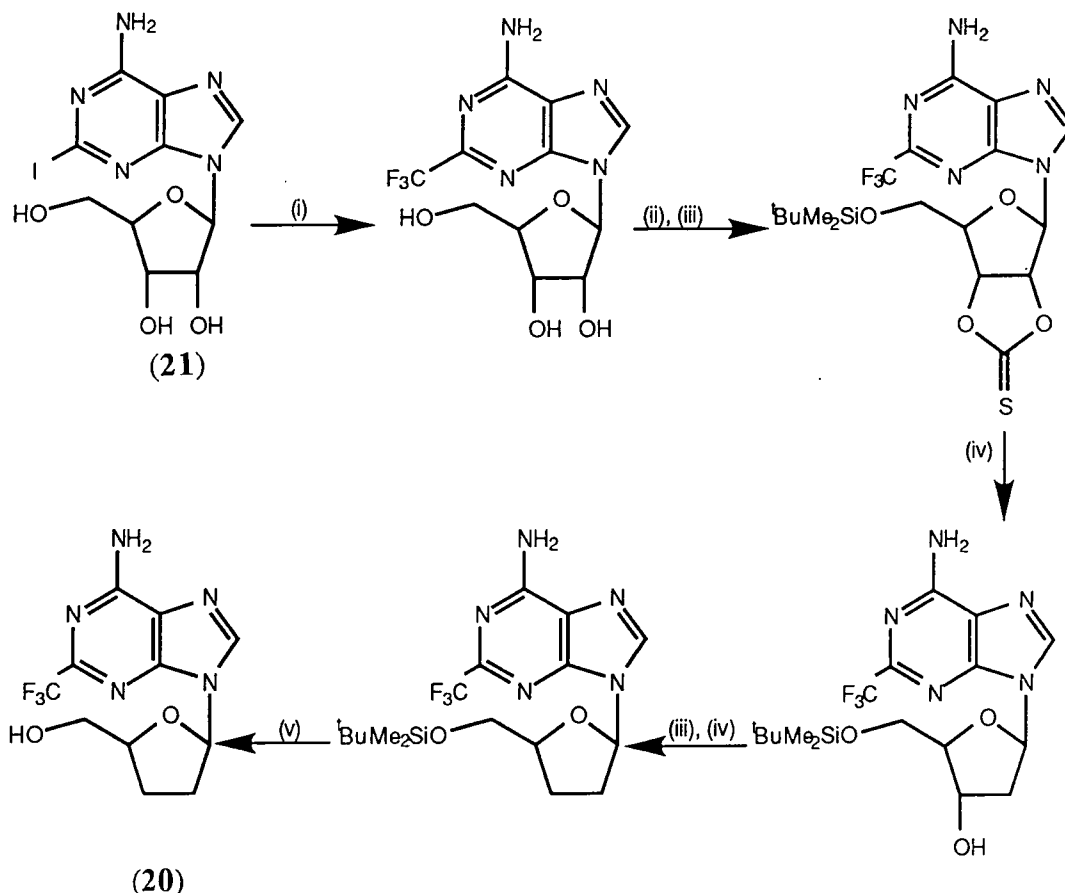

(i) CF_3ZnBr , CuBr , DMF, HMPA; (ii) ${}^t\text{BuMe}_2\text{SiCl}$, 4-(dimethylamino)pyridine, Et_3N , DMF, CH_2Cl_2 ; (iii) 1,1'-thiocarbonyldiimidazole, DMF; (iv) ${}^n\text{Bu}_3\text{SnH}$, AIBN, PhMe, Δ ; (v) Et_4NF , MeCN.
scheme 1.8

These derivatives were totally resistant to hydrolytic deamination by mammalian adenosine deaminase, and were inherently more stable with respect to glycosidic bond cleavage than their parent compounds.

I.C.2.b.(ii) Modification at C6 in the ring

Substitution of fluorine into the C6 position of purine analogues is easily accomplished by aromatic nucleophilic substitution. 6-Chloropurine derivatives of nucleosides, *e.g.* (22), undergo facile halogen exchange with silver fluoride in toluene or xylene to give the corresponding 6-fluoroderivative.⁶¹

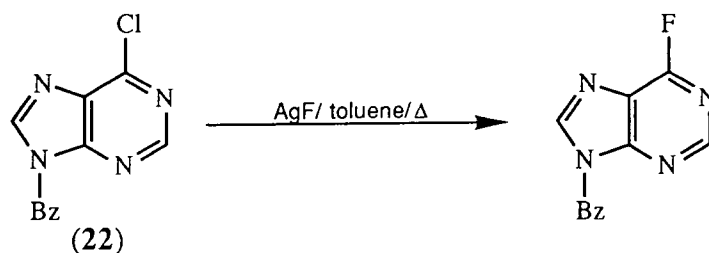

Alternatively 6-trimethylammoniopurines, although having a tendency to undergo alkyl migration,⁶² are amenable to nucleophilic substitution a process which has only begun to be explored. The ease of production of 6-fluoropurines by the reaction of the

quaternized product with KHF_2 or KF in ethanol⁶³ or DMF ^{64,65} is evidence for the great potential of this method; seen previously in scheme 1.7.

Biological activity of such analogues is of little importance, due to the highly reactive and hence, unstable nature of the subsequent 6-fluoronucleosides *e.g.* rapid hydrolysis. Therefore, there use is one of key intermediate,⁶³ were the fluoro group can be nucleophilically displaced to give more stable and hopefully more active analogues.

I.C.2.b.(iii) Modification at C8 in the ring

Little work has been carried on the substitution of the fluoro group in the C8 position of purine derivatives due, unfortunately, to variable results. However, Robins *et al.*⁶⁶ successfully obtained halogen displacement of a chloro-group utilising caesium fluoride and 18-crown-6 as a phase transfer agent to give (23).

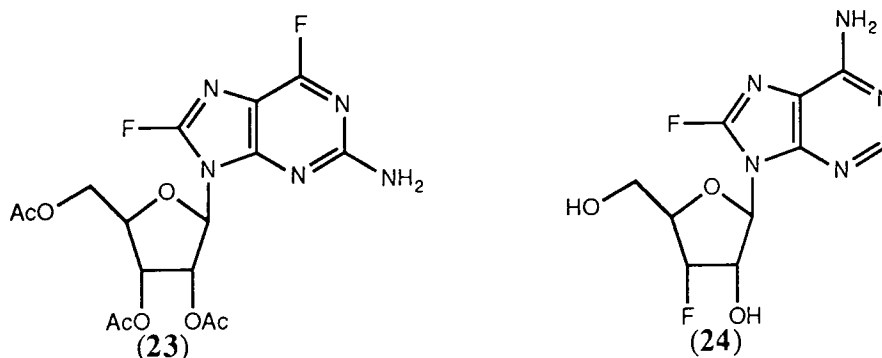

A Japanese group⁶⁷ have synthesised a range of 8-fluoroadenosine derivatives as antitumour agents *e.g.* (24). Although the effective mode of action for these C8 substituted compounds is unclear.

I.C.3 Sugar Modified Derivatives

The field of fluorinated sugar nucleosides is vast, with numerous methods described in the literature for introducing the fluorine moiety. Reviews and treatise on these subjects are readily available,^{68,69} so only a few examples will be covered in this section to give a flavour of the area.

Base modification of nucleosides has led to a number of antiviral compounds now used clinically, however, these have tended to be pyrimidine derived analogues rather than purines. With the purine series, greater success was to be achieved when the modification has been made on the sugar ring.

I.C.3.a C2' Fluoronucleosides

The lead compound for this group of antiviral agents was a naturally occurring pyrimidine nucleoside analogue 1- β -D-arabinofuranosylthymine ARA-T (25), which

was isolated from the sponge *Cryptoethya crypta*.⁷⁰ In ARA-T the C2' position is no longer deoxy, but has a hydroxyl group with the epimeric configuration to that of a ribonucleoside. This compounds displays excellent activity against HSV1 and HSV2 as well as low cytotoxicity. The nucleoside is only activated by virally encoded TK, and shows no efficacy against TK mutants. Compound (25) represents one of the few naturally occurring antiviral agents, but was rapidly superseded by more potent synthetic analogues.



Replacement of the thymidine base by adenine gave ARA-A (26),⁷¹ the first potent adenine derived antiviral agent. It was found to have broad spectrum antiviral properties, inhibiting not only HSV DNA polymerase, as the triphosphate, but also other viral and cellular processes; including activity against some RNA viruses; the higher cytotoxicity of ARA-A over (25) may be due to this diversity of action.

ARA-A was itself superseded in 1979 by the introduction of fluorine in the C2' position; fluorine presumably acting as a hydroxyl mimic. The 2'-fluoroarabinose sugar derivatives are some of the most potent and selective inhibitors of HSV-1 and HSV-2, with 1-(2'-fluoro-5-iodo- β -D-arabinofuranosyl)cytosine FIAC (27)⁷² and 1-(2'-fluoro-5-methyl- β -D-arabino-furanosyl)uracil FMAU (28)⁷³ emerging as the most potent of the series. These compounds have been prepared in 11 and 12 steps respectively (scheme 1.9).

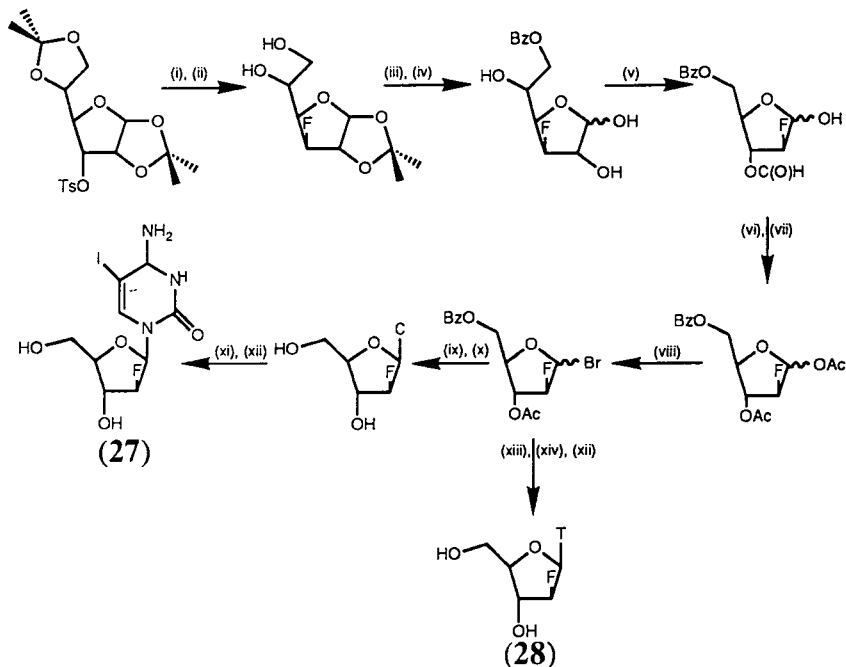

(i) KF, acetamide, 210°C; (ii) TsOH, MeOH; (iii) PhCOCl, pyridine; (iv) amberlite IR-120 (H⁺); (v) KIO₄, H₂O; (vi) NaOMe, MeOH; (vii) Ac₂O, pyridine; (viii) CH₂Cl₂, HBr; (ix) disilyl-4N-acetyl-cytosine; (x) NH₃, MeOH; (xi) AcOH, HIO₃, I₂, CCl₄, H₂O, 40°C; (xii) Amberlite IR-120 (H⁺); (xiii) disilyl-4N-acetyl-5-methyl-cytosine (xiv) 80% AcOH, Δ .

scheme 1.9

Fox and co-workers reported that the 2'-hydrogen, 2'-hydroxy or even the 2'-deoxy-2'-fluororibosugar conferred poorer antiherpes activity than the 2'-fluoroarabinosugar derivatives, highlighting the importance of the C2' position in determining antiviral and cytotoxic activity.⁷³

FIAC (27) highlights an important principle which recurs in antiviral chemotherapy, in that it combines the potency of a C5 substituted base with that of an arabinose sugar derivative, and therefore gains activity lost due to the hydrolysis of the modified C5 congeners such as BVDU (8). Scheme 1.10 illustrates the stabilisation conferred to acid hydrolysis *in vivo* by the electron withdrawing 2'-fluoro substituent.⁷⁴

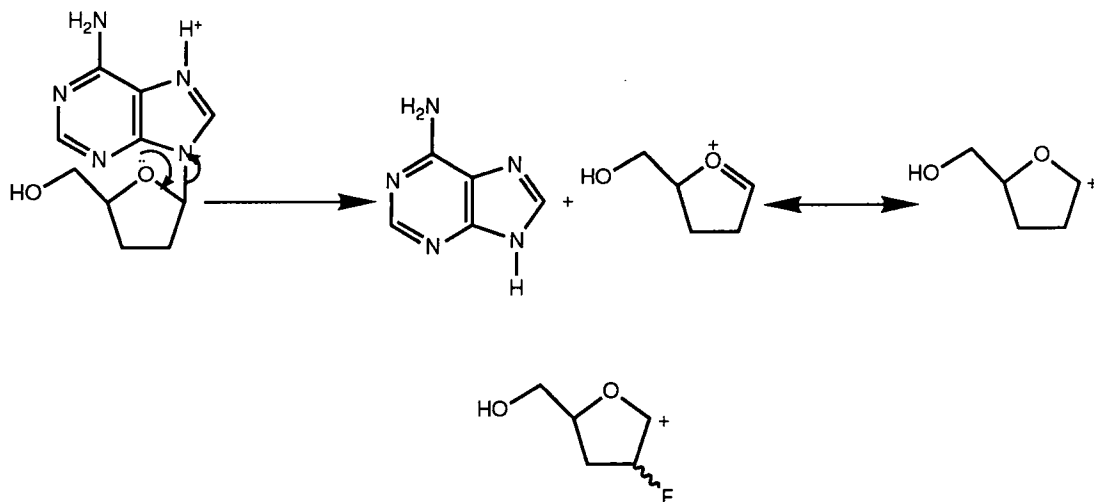

scheme 1.10

FMAU (28) demonstrated a lower cytotoxicity than (26) and (27), however, more recently it has been demonstrated that 1-(2'-fluoro-5-ethyl- β -D-arabinofuranosyl)uracil (29) is a less toxic congener with similar efficacy.⁷⁵

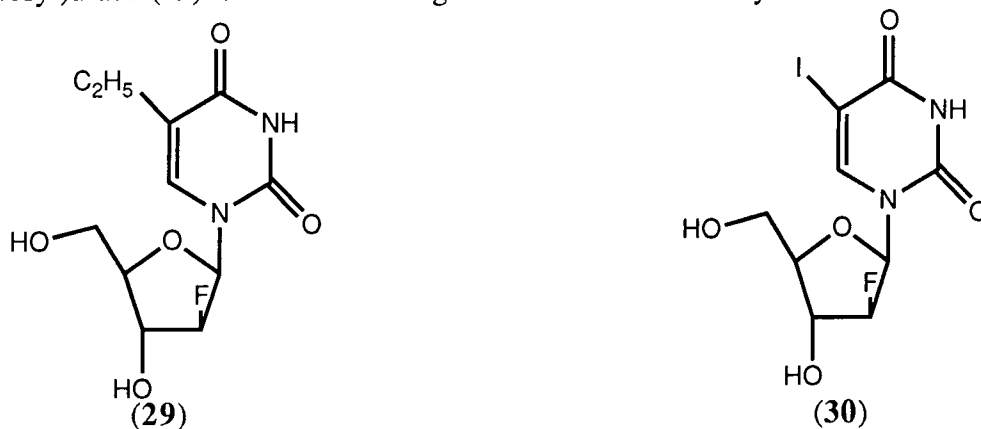

One strategy for enhancing the pharmacokinetics of the FIAC and FMAU was exploited by Biggadike *et al.*,⁷⁶ who synthesised the C6' carbocyclic analogues (31) and (32), which is the active metabolite of FIAC 1-(2'-fluoro-5-iodo- β -D-arabinofuranosyl)uracil (30) (scheme 1.11).

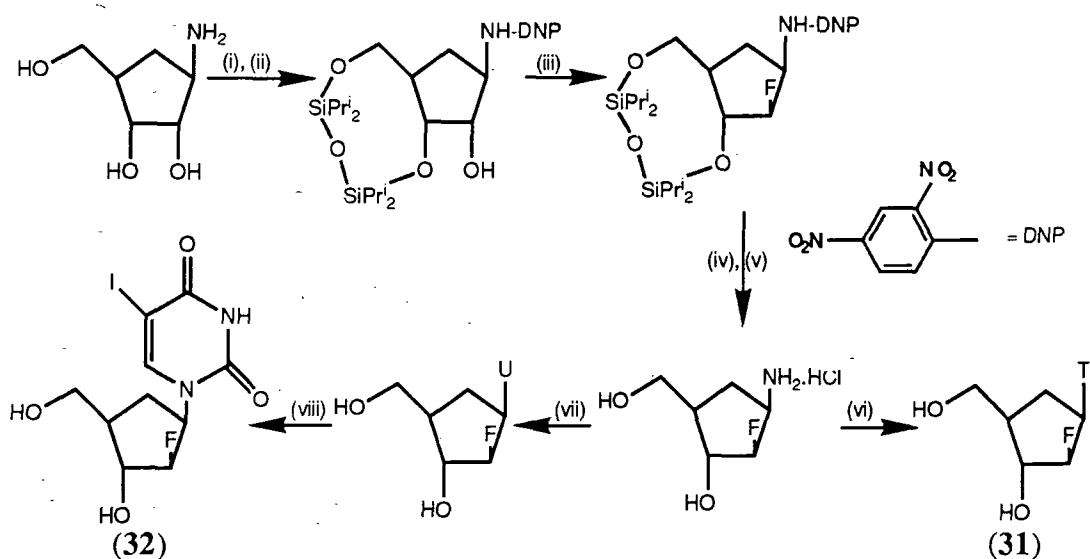

(i) DNP-F, DMF, Na_2CO_3 ; (ii) $O(iPr_2SiCl)_2$, DMF, imidazole; (iii) DAST, CH_2Cl_2 , $-30^\circ C$; (iv) nBu_4NF , THF; (v) Amberlite IR400 (OH⁻), H_2O , MeOH; (vi) EtOCH:C(Me)CONCO, DBU, DMF, $-20^\circ C$, then 2M HCl; (vii) EtOCH:CHCONCO, DBU, DMF, $-20^\circ C$, then 2M HCl; (viii) I_2 , HNO_3 , $CHCl_3$.

scheme 1.11

The carbocyclic derivative of FMAU (31) showed a large reduction in antiviral activity *i.e.* a drop of two orders of magnitude, while (32) displayed negligible activity. However, the synthesis of the carbocyclic derivative of 2'-fluoroaraguanosine, itself inactive, opened the way to a new highly potent anti-herpatic agent (33), scheme 1.12,⁷⁷ demonstrating for the first time carbocyclic derivatives were active in their own right and not merely stable forms of the furanose derivative.

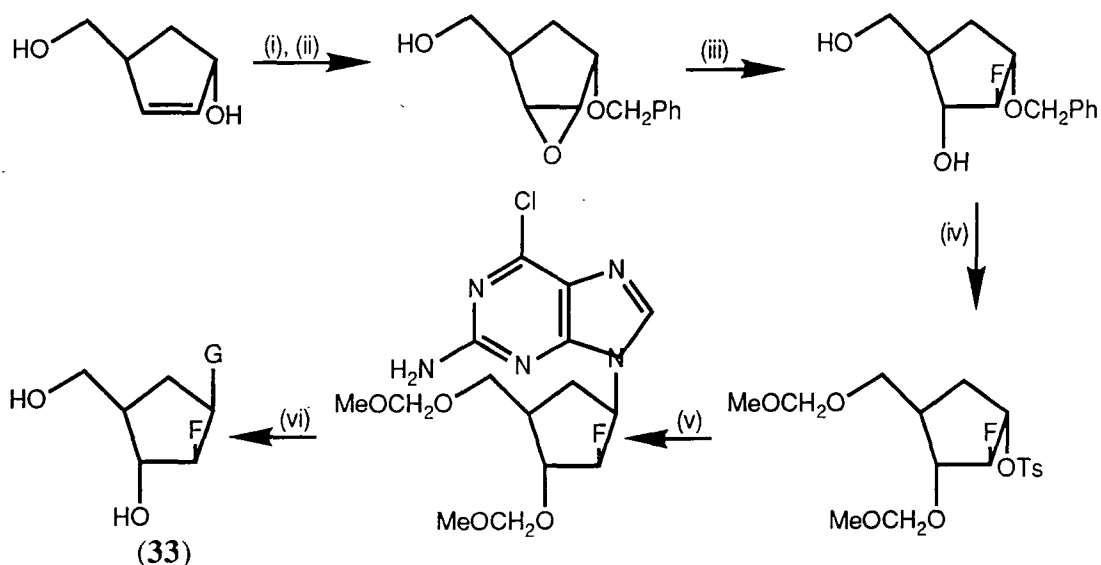

(i) tBuO_2H , PhMe, $VO(acac)_2$; (ii) NaH, THF, N_2 , then $PhCH_2Br$, nBu_4NI ; (iii) KHF_2 , $(CH_2OH)_2$, $150-160^\circ C$; (iv) $MeOCH_2Cl$, iPr_2NEt , CH_2Cl_2 , then Pd-C, H_2 , EtOAc, H_3O^+ , then TsCl, Et_3N , 4-(dimethylamino)pyridine; (v) K_2CO_3 , DMSO, 2-amino-6-chloropurine, $80^\circ C$; (vi) 1M HCl, Δ .

scheme 1.12

In 1989 McCarthy⁷⁸ synthesised a range of novel mono- and di-halomethylidene nucleosides *via* dihalomethylidene ylides and aryl sulphonylhalomethylidene derivatives, which allowed conversion to the 2'-halomethylidene nucleosides (34) (scheme 1.13).

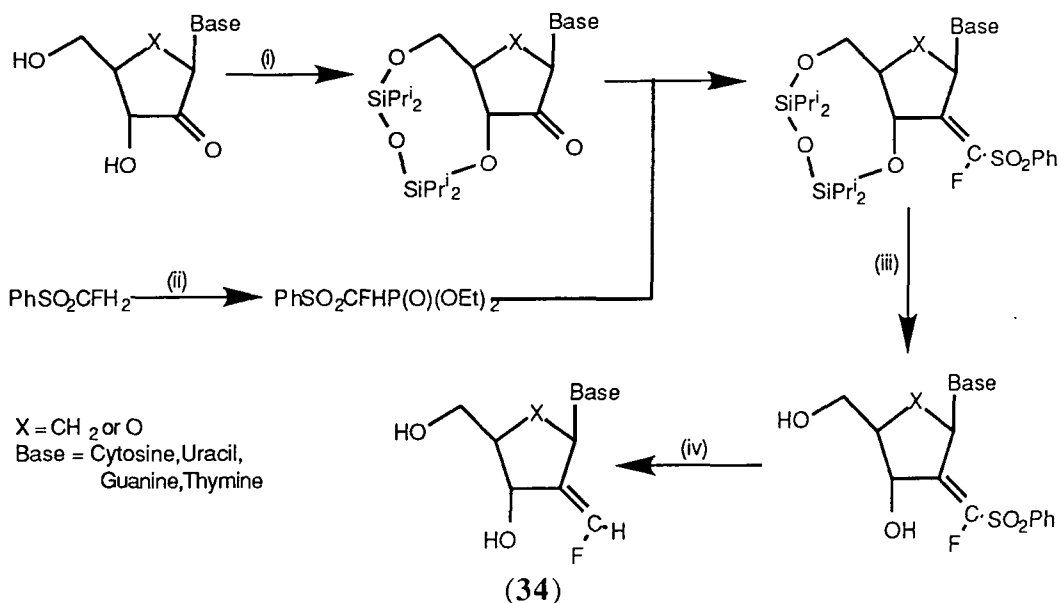

(i) $O(iPr)_2P(O)Cl$, DMF, imidazole; (ii) $(EtO)_2P(O)Cl$, LDA, THF, $-78^\circ C$; (iii) tBu_4NF , THF; (iv) Al/Hg , Δ .
scheme 1.13

M^cCarthy *et al.* claimed that these compounds exhibit broad spectrum activity not only against HSV1 and HSV2 but also retroviruses *i.e.* a single stranded RNA virus in which the RNA is its own messenger and activates an RNA-directed DNA polymerase, a reversal of the normal DNA-RNA protein sequence.

Greater success against retroviruses, especially Human Immunodeficiency Virus (HIV), came when it was found that dideoxysugars, a group of nucleoside analogues lacking the 3'-hydroxyl group of the 2'-deoxyribosugar, showed high activity against reverse transcriptase (RT). They acted in the form of their triphosphates as DNA chain terminators; indeed the differences within the group of compounds (19), and (35)-(38) seem to be tied into their relative ability to be phosphorylated *in vivo* to the triphosphate.

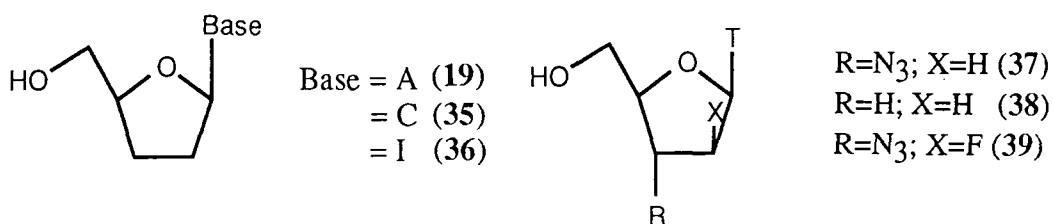

The RT inhibitory activity of AZT (37) was shown in the early 1970s, and it therefore came to the fore for the control of the HIV virus.⁷⁹ Since HIV does not specify its own TK to convert nucleosides to the monophosphates cellular enzymes must perform this task. Compound (37) shows specificity as the triphosphate by inhibiting HIV RT one hundred fold better than cellular DNA polymerase.⁸⁰ The success of (37) spawned a large number of congeners, Blackburn *et al.* synthesising 1-(3'-azido-2',3'-dideoxy-2'-fluoro- β -D-arabinofuranosyl)thymine (39),⁸¹ Fox and coworkers⁸² making 1-(3'-azido-2',3'-dideoxy-2'-fluoro- β -D-ribofuranosyl)thymine (40), both inactive against HIV1 (scheme 1.14).

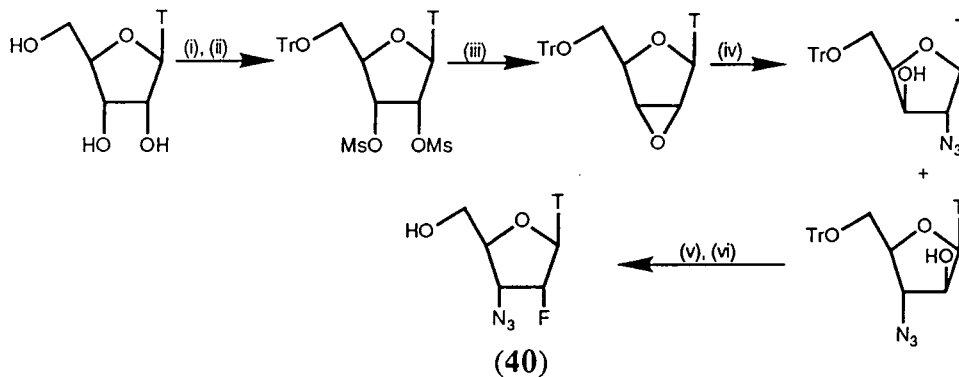

(i) Ph_3CCl , pyridine, 50°C ; (ii) $\text{CH}_3\text{SO}_2\text{Cl}$; (iii) EtOH, 1N NaOH, then 80% AcOH; (iv) LiN_3 , EtOH, Δ ; (v) DAST, PhH, -5°C ; (vi) 80% AcOH, Δ .

scheme 1.14

The dideoxy nucleoside analogue (19) and its biological composite (36), figure 1.4, are potent inhibitors of HIV but suffer from extreme acid instability.

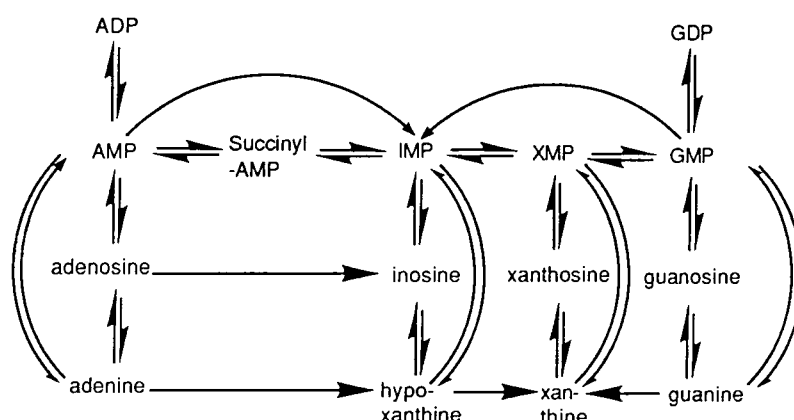

Cellular interconversion of adenine derivatives to guanine derivatives *via* inosine.
figure 1.4

It was seen previously that the introduction of an electron withdrawing group obviates this process, thus 2'-fluoro arabinose derivatives of (19) and (36) were synthesised (scheme 1.16).⁷⁴

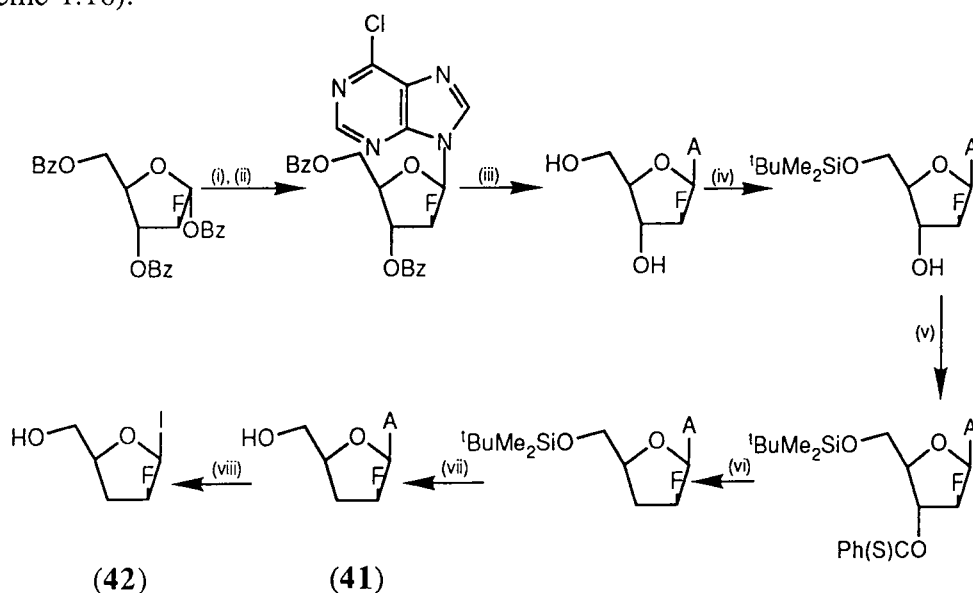

(i) HBr, HOAc, CH_2Cl_2 ; (ii) N9-trimethylsilyl-6-chloropurine; (iii) NH_3 , MeOH, 100°C ; (iv) $^t\text{BuMe}_2\text{SiCl}$, imidazole; (v) PhCSCl , 4-(dimethylamino)pyridine; (vi) $^n\text{Bu}_3\text{SnH}$, AIBN, PhMe, Δ ; (vii) $^n\text{Bu}_4\text{NF}$, THF; (viii) H_3O^+ , NaNO_2 .

scheme 1.16

Both (41), (42) and the α -fluorosubstituted derivative of (41) all showed increased acid stability, but for biological activity the fluorine atom had to be in the β - position, the analogues (41) and (42) showing potent efficacy against the HIV virus equal to that of the clinically used non-fluorinated analogues (19),(35),(36) and AZT (37).

I.C.3.b C3' Fluoronucleosides

The importance of the 3' position in nucleosides has already been seen in the dideoxy class of compounds which lack a 3'-hydroxy group paramount for the biosynthesis of DNA or RNA, which are built up from phosphate linked nucleosides bound at the 5' and 3' position. Etzold and co-workers, therefore, synthesised the fluorinated congener of (38), viz. 2',3'-dideoxy-3'-fluorothymidine (43), utilising hydrogen fluoride in the presence of a Lewis acid.⁸³ Later Fox and *et al.*⁸² came up with a more efficient synthesis of (43) (scheme 1.18) as well as the AZT analogue 2'-azido-2',3'-dideoxy-3'-fluorothymidine (44).

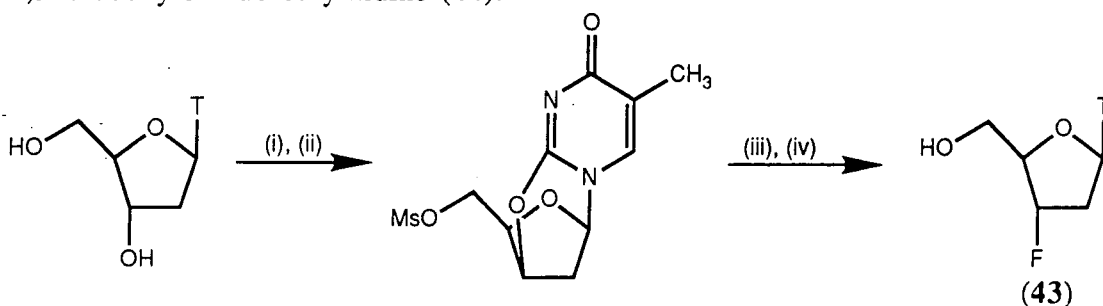

(i) MeSO_2Cl , pyridine; (ii) H_2O , $\text{pH} < 5$; (iii) HF , AlF_3 ; (iv) OH^- , EtOH .

scheme 1.18

Compound (43) showed good activity against HIV-1 and increased stability of the glycosidic link, *cf.* C2' substitution, over the thymidine derivative, while (44) showed no significant antiviral properties. Two groups reported the stereospecific synthesis of the carbocyclic analogue of (43),^{84,85} one utilising a chemicoenzymic approach⁸⁴ starting with the enzymic transformation of (\pm)-*endo*-5-norbornen-2-ol to give (1*R*,3*R*,4*R*)-4-hydroxy-cyclopentane-1,3-dimethanol and the corresponding (*S*)-enantiomer (scheme 1.19), but as yet no biological data is available

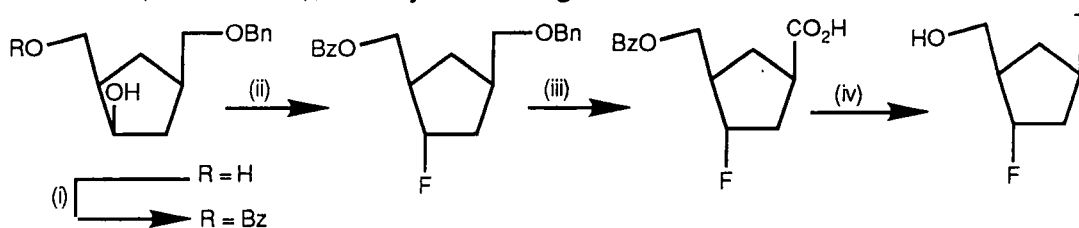

(i) PhCH_2Cl , CH_2Cl_2 , pyridine; (ii) DAST , CH_2Cl_2 , -70°C ; (iii) pyridinium chlorochromate; (iv) $\text{Ph}_2\text{P}(\text{O})\text{N}_3$.

scheme 1.19

Other 3'-deoxy-3'-fluoronucleobases, *e.g.* (45)⁸⁶ and (46),⁸⁷ have been synthesised which show inhibition of RT, the uracil derivative (46) prepared by a similar route to scheme 1.19; however, only 31% of the desired isomer was produced and 47%

of the 2'-fluoroisomer (47) via rearrangement of 2,3'-anhydro-1-(β -D-xylofuranosyl)-uracil to the 2,2'-anhydro intermediate.⁸⁷

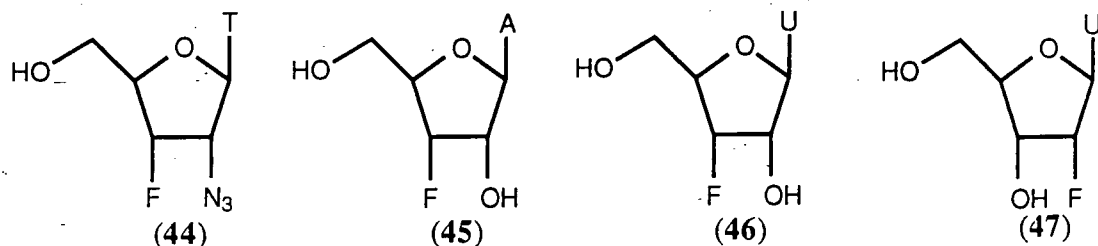

Seela and Rosemeyer⁸⁸ rationalised that given the potency of (45), and its poor stability to adenosine deaminase, that the 3'-fluorotubercidin derivative (48) would be a better RT inhibitor (scheme 1.20), and indeed the 7-deazaadenine group showed no sign of degradation by cellular enzymes.

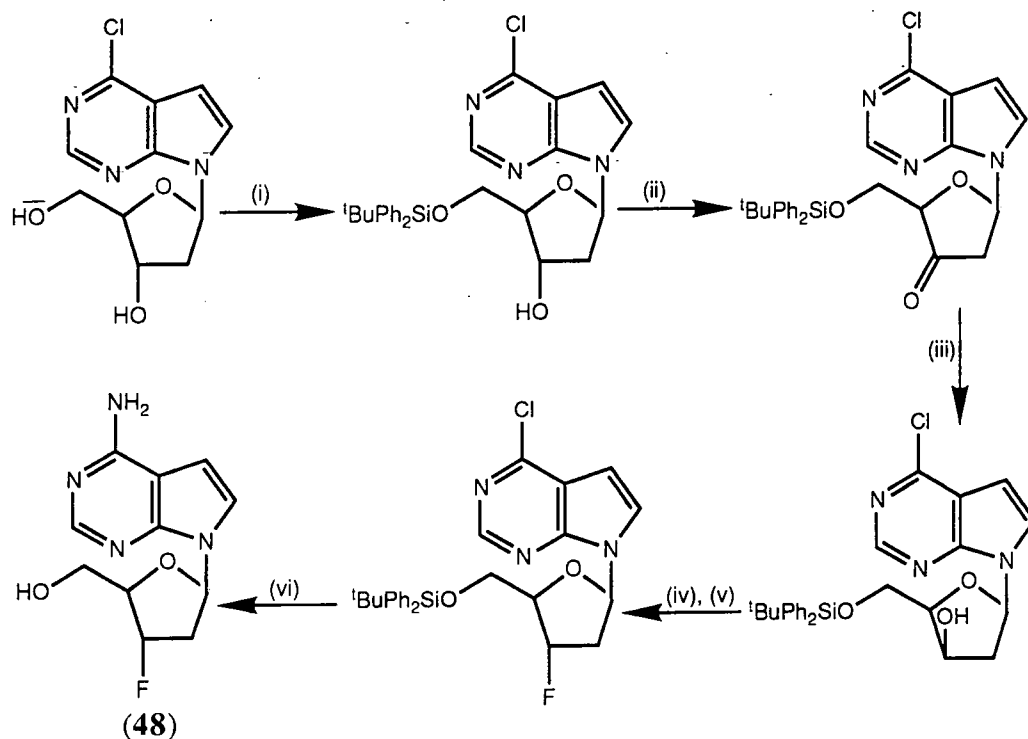

(i) $t\text{BuPh}_2\text{SiCl}$, DMF, imidazole; (ii) CrO_3 , pyridine, Ac_2O , CH_2Cl_2 ; (iii) NaBH_4 , EtOH, 0°C ; (iv) DAST, PhMe; (v) $n\text{Bu}_4\text{NF}$, THF; (vi) NH_3 , MeOH, Δ .

scheme 1.20

More recently Coe *et al.*⁸⁹ modified the 3' position by using mono- and difluoromethylene as a hydroxyl mimic, thus introducing the extra dimension of hydrogen donation. Scheme 1.21 demonstrates the reaction pathway starting from the 3'-C-(4,5-dihydro-5-methyl-1,3,5-dithiazin-2-yl) analogue (49), utilising diethylaminosulphur trifluoride (DAST), none of the C3' fluorosubstituted methyl derivatives shared any activity.

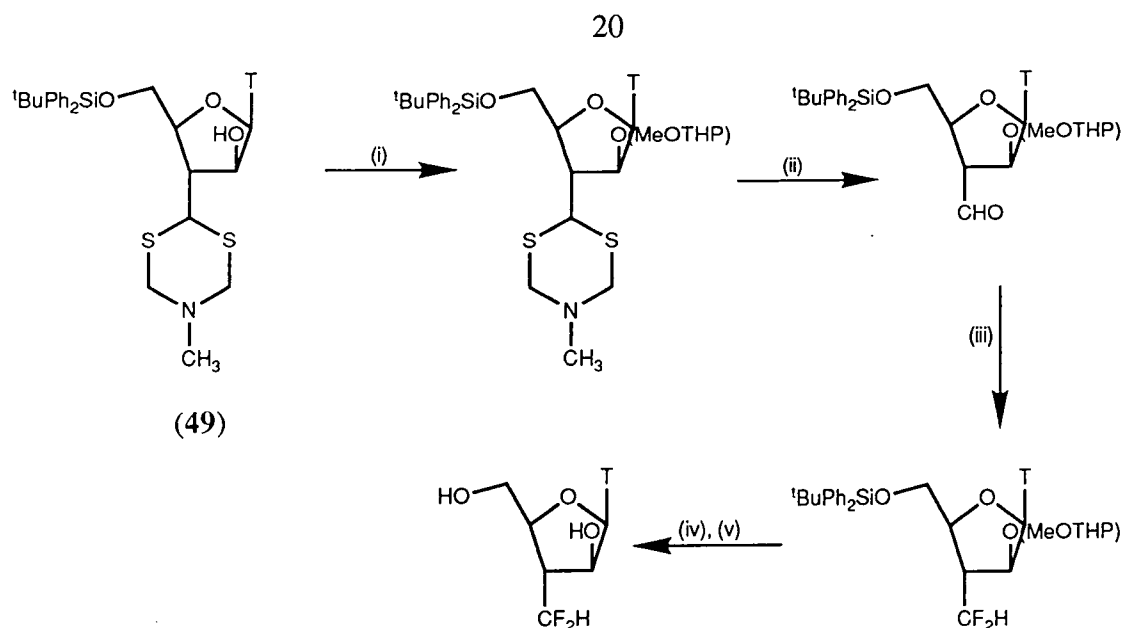

(i) 4-methoxy-5,6-dihydro-2H-pyran (MeOTHP), TsOH, dioxane; (ii) HgO, HgCl₂, H₂O, THF; (iii) DAST, CH₂Cl₂; (iv) ^tBu₄NF, THF; (v) 0.01M HCl, 1,4-dioxane, then 0.01M NaOH.

scheme 1.21

This lack of activity was prescribed to the fluoronucleosides adopting the C3'-endo sugar conformation. Recent studies suggest a C3'-exo conformation is necessary for anti-HIV activity⁹⁰ (figure 1.5).

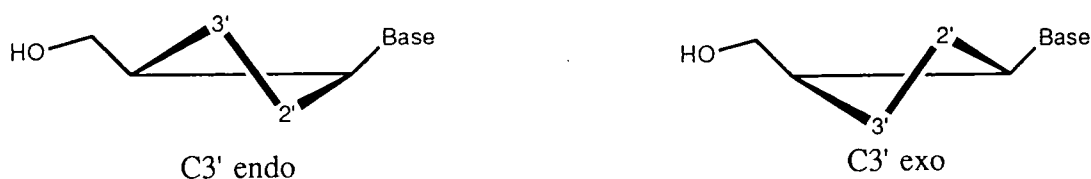
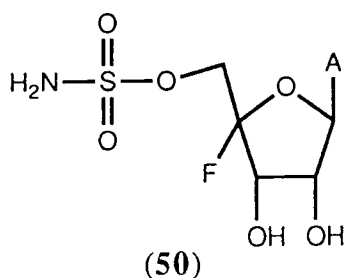

figure 1.5

I.C.3.c C4' Fluoronucleosides

Nucleocidin (**50**)⁵ is one of the few naturally occurring compounds to contain fluorine and despite its inherent antibiotic properties, very little work was done on the synthesis of other C4' fluoronucleosides.



Verheyden and co-workers in 1973 successfully synthesised nucleocidin *via* an addition reaction to a 4',5'-unsaturated nucleoside.⁹¹ Extending this methodology, they went on to synthesis the uracil derivative (**51**)⁹² and the monophosphate (**52**) (scheme 1.22).

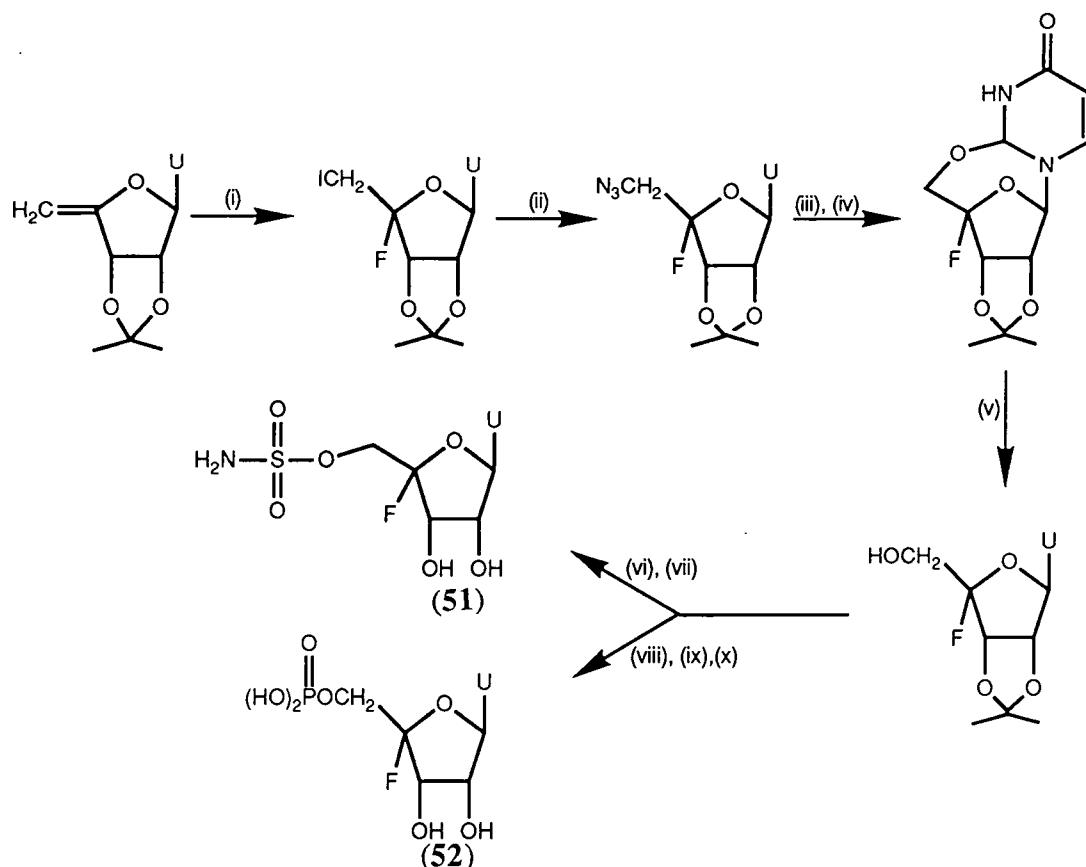

scheme 1.22

Biologically it was found that *in vitro* the C4' substituted derivatives (51) and (52) exhibited decreased stability to hydrolysis in both acid and alkali conditions, this led Danenburg to synthesis the fluoronucleoside 5'-deoxy-4',5-difluorouridine (53) as a new prodrug for 5-fluorouracil (scheme 1.23).⁹³

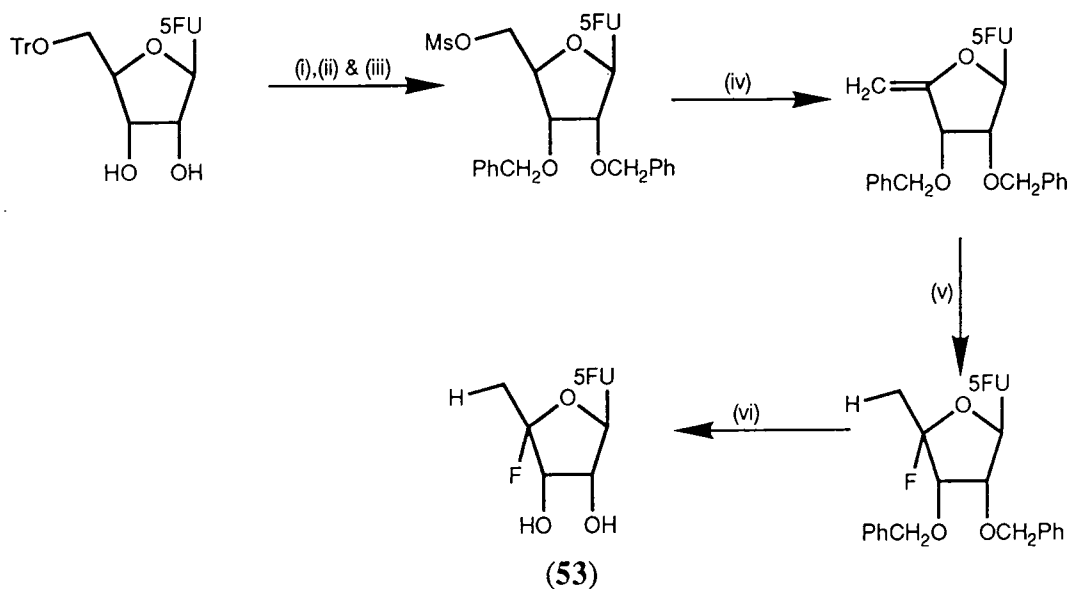

scheme 1.23

A number of carbocyclic 4'-fluoro derivatives have also been prepared, *e.g.* of the potent carbocyclic antiherpes drug 2'-fluoro-araguanosine (**32**), using DAST to introduce fluorine at C4' effectively in the last step of the reaction (scheme 1.24).⁹⁴

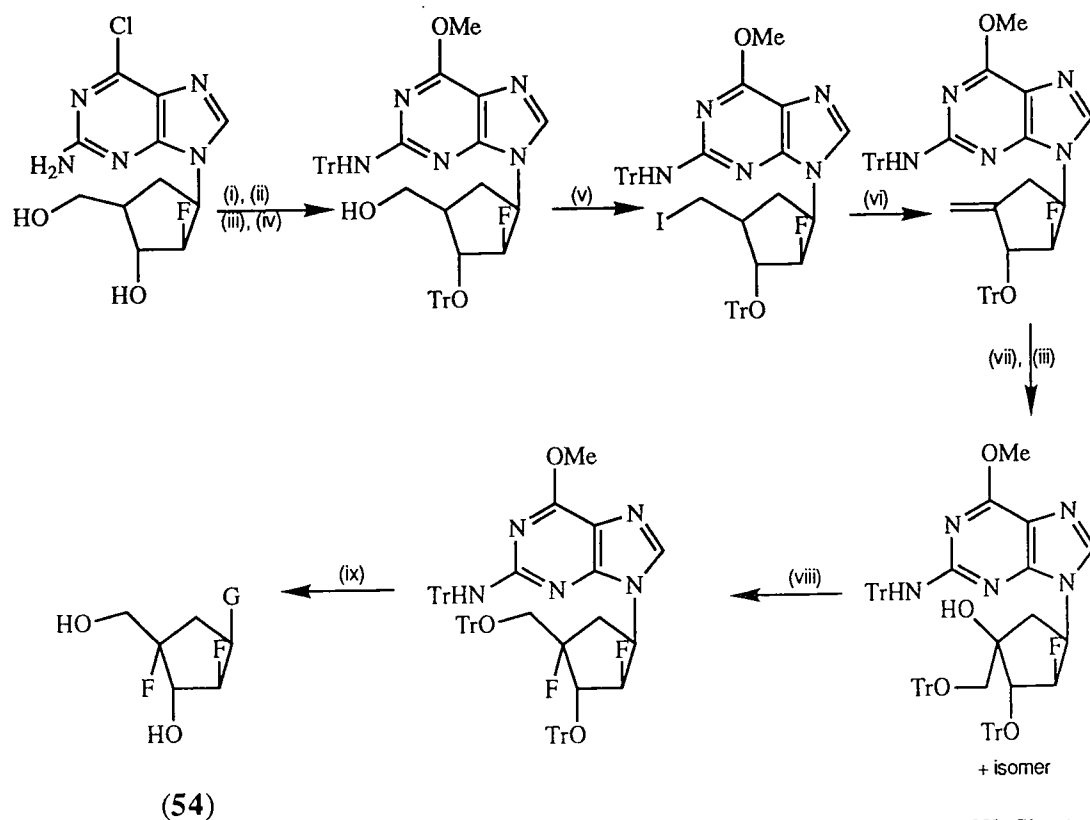

(i) NaOMe, MeOH, 50°C; (ii) ^tBuMe₂SiCl, imidazole, DMF; (iii) Ph₃CCl, molecular sieve, CH₂Cl₂, Δ; (iv) ⁿBu₄NF, THF; (v) (PhO)₃PMeI, THF, -65 to 0°C; (vi) DBN, pyridine, 60°C; (vii) OsO₄, pyridine; (viii) DAST, CH₂Cl₂, 0°C; (ix) AcOH, 80°C, then 2M HCl, 80°C.

scheme 1.24

The 4'- α -fluoro derivative (**54**) displayed potent activity against HSV1 and 2, animal tests showing a thirty fold increase in efficacy over acyclovir (**55**) against HSV2 in mice.

I.C.3.d C5' Fluoronucleosides

Fluorination or polyfluoroalkylation at the C5' position of nucleosides is relatively simple, *e.g.* displacement of sulphonates using tetrabutylammonium fluoride will introduce 5'-fluorogroups. The removal of the hydroxyl group does though introduce the problem that phosphorylation can no longer take place in the 5' position to yield nucleotides; a consequence exploited in designing prodrugs for 5-fluorouracil.⁹³ This, however, has not disqualified substituted C5' nucleosides as potential antiviral agents, as the activity of such analogues is expressed through different cellular pathways.

The enzyme *S*-adenosyl-*L*-homocysteine (SAH) hydrolyase is responsible for the hydrolytic cleavage of SAH (**56**) to adenosine and *L*-homocysteine *in vivo*⁹⁵ (scheme 1.25). This important process indirectly, *via* a feedback mechanism, regulates biological methylation and is required by many viruses for 5' capping of mRNA.

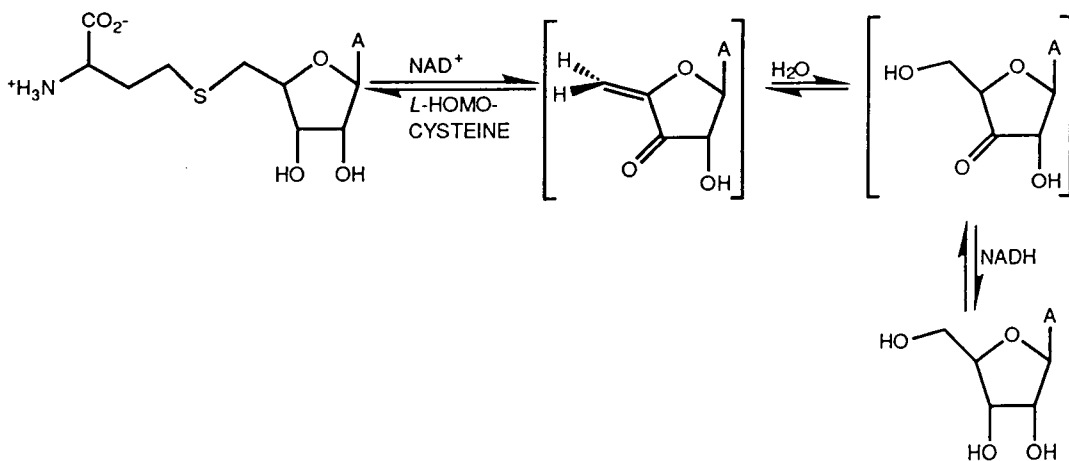

scheme 1.25

Robins and Wnuk⁹⁶ synthesised a series of 5'-*S*-aryl(alkyl)thio-5'-fluoronucleosides *e.g.* (57) (scheme 1.26) to act as SAH inhibitors, as did McCarthy *et al.*⁹⁷ who synthesised some novel fluoroalkenyl derivatives (58a) and (58b). All of these compounds exhibited both inhibition of the enzyme SAH and antiretroviral activity *in vitro*, (58a) exhibiting the greatest potency.⁹⁸

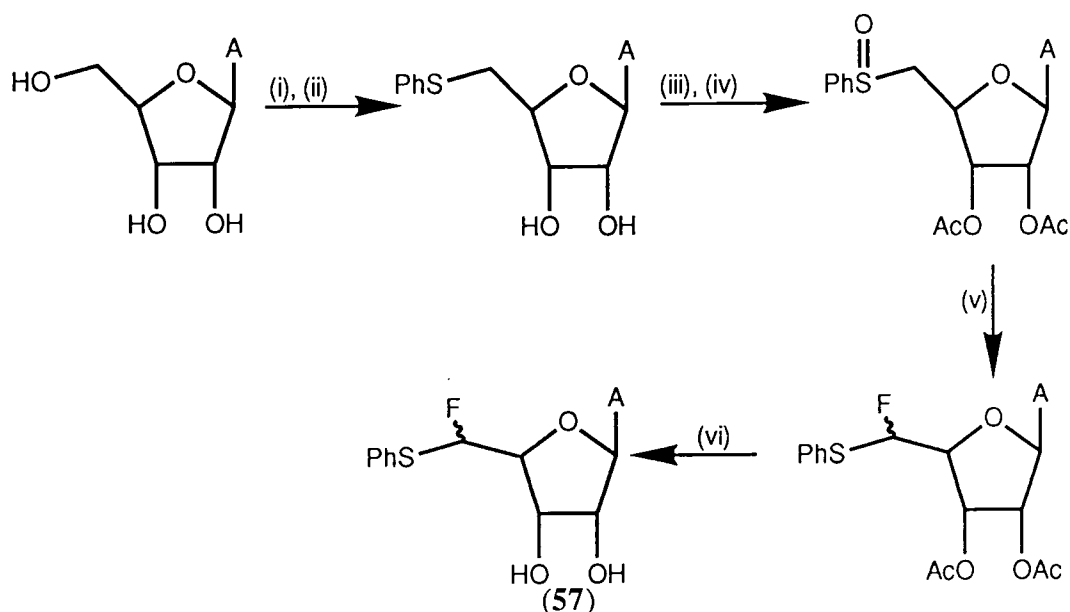

(i) SOCl₂, pyridine, MeCN, then NH₃, MeOH, H₂O; (ii) PhSH, NaH, DMF; (iii) Ac₂O, pyridine; (iv) 3-chloroperoxybenzoic acid, CH₂Cl₂, -40°C; (v) DAST, SbCl₃, CH₂Cl₂; (vi) NH₃, MeOH.

scheme 1.26

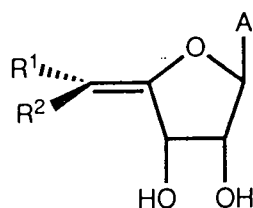

R¹=F, R²=H (58a), R¹=H, R²=F (58b)

Another similar class of compounds to those of Robins and Wnuk were prepared as inhibitors of 5'-deoxy-5'-(methylthio)adenosine (MTA) phosphorylase, used in the biosynthesis of polyamines⁹⁹ *e.g.* spermine. The acetal of adenosine was treated with thionyl chloride to yield the 5'-chloronucleoside (59), which was nucleophilically

displaced by 2-thioethanol, subsequently treated with DAST and deprotected to give 5'-deoxy-5'-[(2-monofluoroethyl)]thioadenosine (**60**)¹⁰⁰ (scheme 1.27).

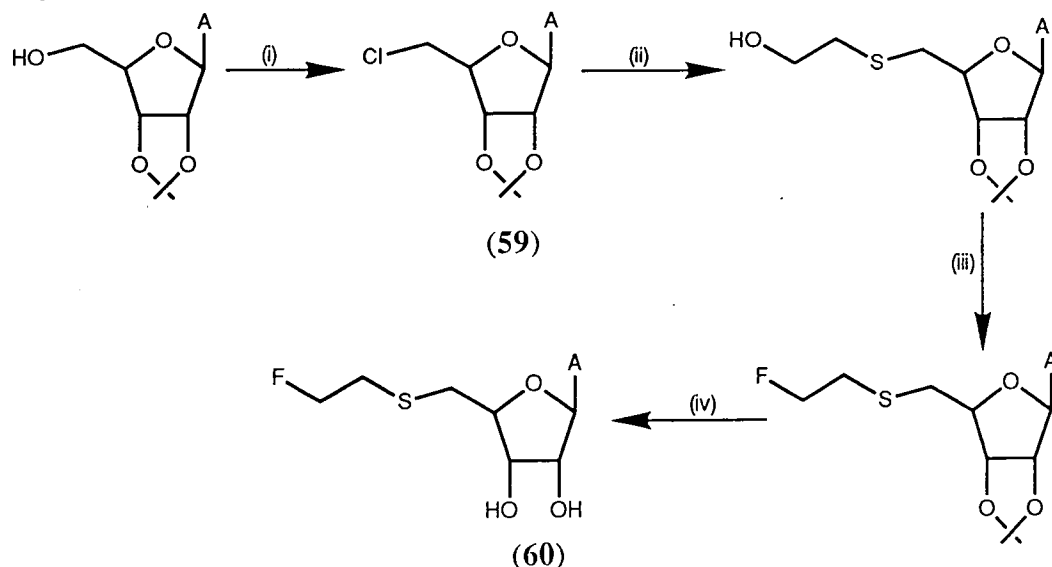

(i) SOCl_2 , HMPA; (ii) NaOH, $\text{HOCH}_2\text{CH}_2\text{SH}$; (iii) DAST, CH_2Cl_2 ; (iv) HCOOH.

scheme 1.27

The fluoroderivative (**60**) proved to be both the most hydrolytically stable of a range of MTA derivatives synthesised, with no degradation after five days in physiological conditions, and a good inhibitory effect on cell growth *in vitro*.

I.C.3.e C6' Fluoronucleosides

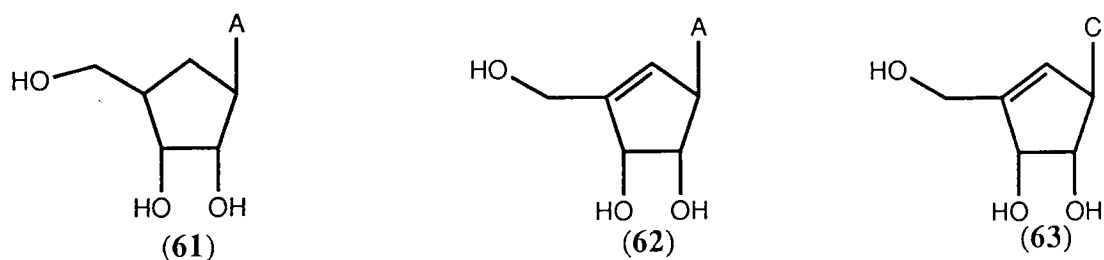

Replacement of the furanose ring oxygen by carbon is of particular interest since the resulting carbocyclic nucleosides possess greater metabolic stability to phosphorylase enzymes,¹⁰¹ which cleave the glycosidic linkage of nucleosides, *e.g.* the deactivation of BVDU (**8**). Carbocyclic nucleosides are not new, aristeromycin¹⁰² (**61**) and its cyclopentenyl derivative neoplanocin A (**62**),¹⁰³⁻¹⁰⁵ are both natural products. From the latter class of compounds the cytosine derivative cyclopentenyl cytosine (**63**) was synthesised,^{106,107} which exhibits both antitumour properties and antiviral properties *in vivo*,⁷⁴ particularly against HSV1 in TK mutants to which acyclovir (**55**) shows no efficacy.¹⁰⁸ However, its toxicity perhaps outweighs this benefit.

Fluorine was introduced in the C6' position to act as an effective mimic for oxygen, especially if the furanose oxygen was required for some polar interaction at the active site. Both the monofluoromethylene¹⁰⁹ and difluoromethylene¹¹⁰ group have therefore been used as a replacement for O6'.

Most work in this field has been carried out by a team including Biggadike and Roberts, who devised a short efficient route to both α -6'- and β -6'-fluoro derivatives *via* the key chiral epoxide (**64**)^{76,111} (scheme 1.28).

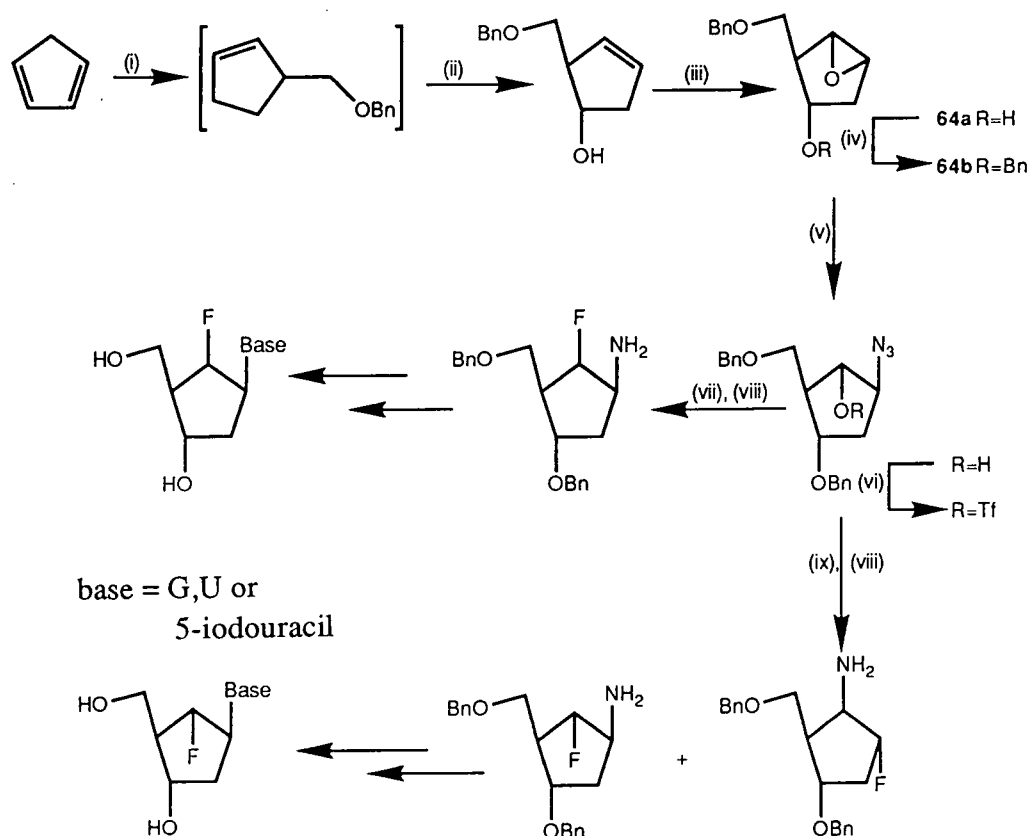

scheme 1.28

They found for both the carbocycles of the pyrimidine series *e.g.* the carbocycle of 5-iododeoxyuridine,⁷⁶ and the purine series *e.g.* carbocyclic 2'-fluoroaraguanosine (**33**),¹¹¹ that the antiviral activity was retained in the α -6'-fluoro derivative (**65**) but abolished in the β -6'-fluoroisomer. This indicates that the configuration at C6' is of significant importance to biological activity, the stereochemistry of the fluorogroup causing a conformational or steric difference adversely affecting antiviral activity.

An alternative approach to 6'- α -fluoro derivatives was therefore developed, relying upon an enzymically controlled Baeyer Villiger reaction.¹¹² Scheme 1.29 demonstrates how the 6'- α -fluoroAZT derivative (**66**) was synthesised by this method; biological activity of this analogue was significantly lower than AZT (**37**), because of conformational differences.¹¹³

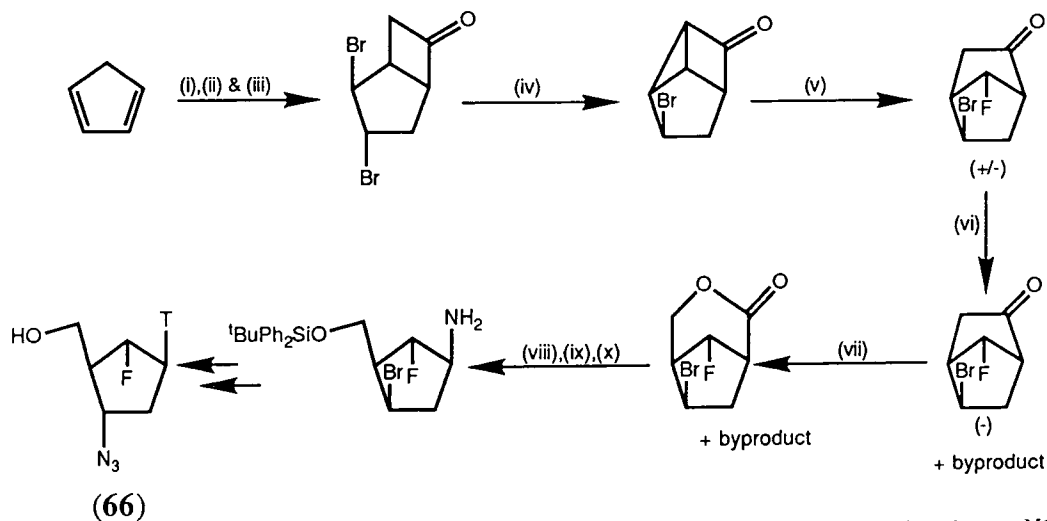

(i) Cl_2CHCOCl , Et_3N ; (ii) Zn , AcOH ; (iii) Br_2 ; (iv) $(\text{Me}_3\text{SiN})_2\text{Na}$; (v) $\text{Et}_3\text{N}\cdot 3\text{HF}$; (vi) *Acinetobacter* NCIB 9871; (vii) 3-chloroperoxybenzoic acid; (viii) NH_3 ; (ix) ${}^t\text{BuPh}_2\text{SiCl}$; (x) $\text{PhI}(\text{OCOCF}_3)_2$.
 scheme 1.29

The 6- α -fluoro carbocyclic variant of 3'-fluorodideoxythymine (**43**) was also synthesised by Roberts *et al.*¹¹³ from cyclopentadiene, however, 6- α -fluoro-3'-fluorodideoxythymine was inactive against HSV1.

I.C.4 Acyclic Fluoronucleosides

Wellcome set out to find an inhibitor of adenosine deaminase to co-administer with such drugs as ARA-A (**26**), thus increasing their efficacy. As part of this work, they looked at derivatives of adenosine in which the sugar was replaced by an acyclic moiety representing a partial sugar structure. Of the compounds synthesised, 9-(2-hydroxyethoxymethyl)adenine was found to be a substrate for the enzyme. The fact this was recognised by an enzyme suggested that other enzymes may recognise this acyclic side chain. This proved to be the case and in 1978 the revolutionary antiherpes agent acyclovir (**55**),¹¹⁴ where adenine was replaced by guanine, and the more potent drug DHPG (**67**) were synthesised.¹¹⁵

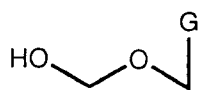

(55)

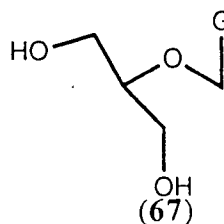

(67)

Acyclovir (**55**) exhibits antiviral activity by acting as a selective irreversible inhibitor of HSV-1 and HSV-2 DNA polymerase.¹¹⁶ To get to the active triphosphate (**55**) must first be monophosphorylated by virally encoded TK. Compound (**55**) is in fact a very poor substrate for cellular TK,¹⁰⁸ but it is further phosphorylated by cellular enzymes to give the active substrate.

Fluorinated acyclic derivatives are neither as potent nor common, loss of activity being associated with fluorine insertion at any site in (67).⁴¹ Abushanab and coworkers¹¹⁷ reported recently a synthesis of a (68) and (69) nucleosides incorporating similar structural features to (28) (scheme 1.30).

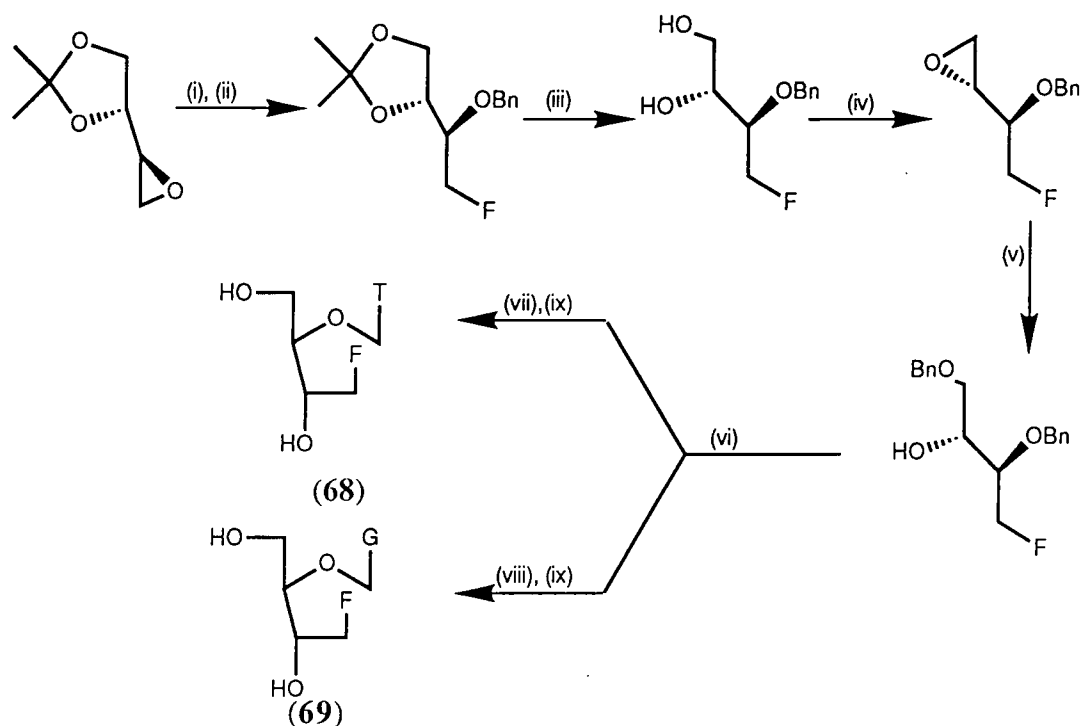

scheme 1.30

The compounds were found to be inactive against HIV1 *in vitro* even when introduced in the monophosphate form. Viani *et al.*¹¹⁸ outlined a synthesis of a class of optically pure nucleosides of the general structure (70), where the base is adenine or thymine. However, no biological test data is yet available.

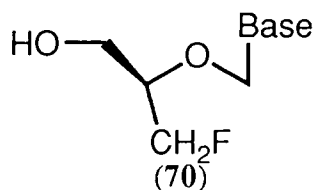

I.D. Fluorine Containing Nucleotides

I.D.1 Introduction

Nucleotides¹¹⁹ are synthesised *in vivo* by phosphorylation of nucleosides, it therefore would seem feasible to alter the physiological properties of nucleotides by modifying not only the nucleic acid residue but also the phosphate groups themselves, figure 1.6.

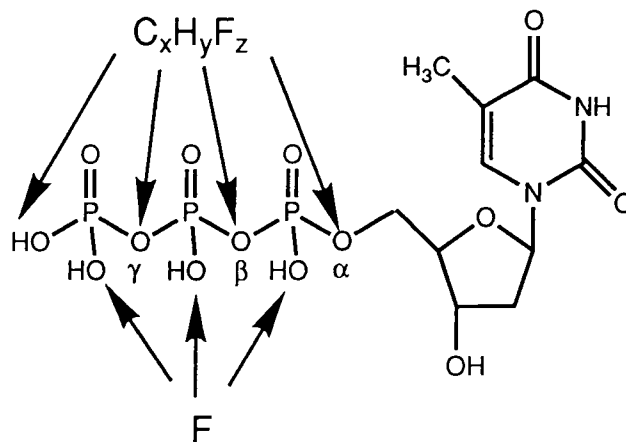
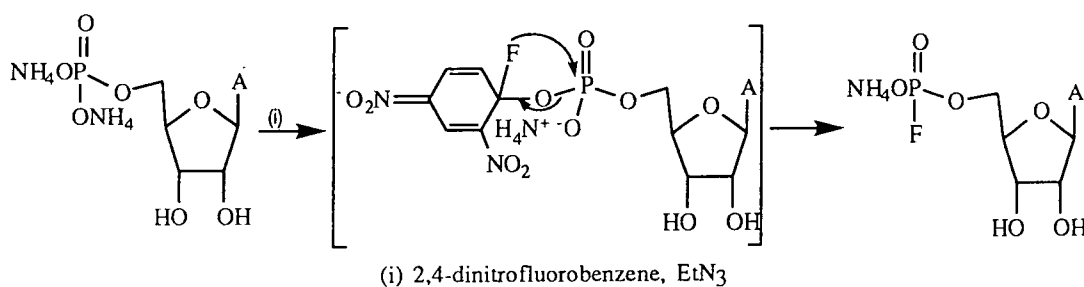

figure 1.6

I.D.2 Fluorophosphates

Generally known for their high toxicity, fluorophosphate analogues have been primarily synthesised for enzymic studies. Their synthesis was accomplished by Wittmann¹²⁰ in 1963, who devised a synthesis of nucleoside monofluorophosphates by aromatic nucleophilic substitution (scheme 1.31). This method is generally applicable.



scheme 1.31

However Sund and Chattopadhyaya¹²¹ found that *O*-aryl-*O,S*-dialkylphosphorothioates of various nucleosides could easily be converted upon treatment with tetrabutylammonium fluoride to the monofluorophosphate, reaction products being dependant on the fluoride ion concentration (table 1.2).

Indeed adenosine 5'-fluorophosphate (**75a**) is incapable of activating glycogen phosphorylase b, yet inhibits the activation of this enzyme by (**74a**), shown to be indicative of the phosphate dianion being the only acceptable substrate.¹²³

I.D.3 Fluoroalkylphosphonates

I.D.3.a α -, α,α -Fluoromethylphosphonates

Reagents are readily available for the incorporation of α - and α,α -fluoromethylphosphonates into nucleosides.^{30,124} This is highly desirable given that the phosphate linkage is hydrolytically labile, unlike the alkylfluorophosphonate derivative, allowing drugs to be administered orally in a potentially activated form, *i.e.* obviating the need for thymidine kinase phosphorylation. The α,α -fluoromethylphosphonate group representing the closest non-chiral analogue to the phosphate group in both physiological pK_a (figure 1.1) and steric bulk.

Acyclic nucleoside derivatives such as DHPG (**67**) show powerful viral inhibition and negligible cytotoxicity, the acyclic sugar moiety inhibiting the enzyme adenosine deaminase, therefore, Casara and coworkers¹²⁵ set out to synthesis the α,α -difluorophosphonate derivative of (**67**). Scheme 1.32 shows the methodology adopted to yield the α,α -difluoromethylphosphonate (**76**) which was then cyclised to (**77**). Compound (**76**) and its congeners were found to have lower activity to the inhibition of HSV-1 and -2 *in vitro* than the parent nucleoside.

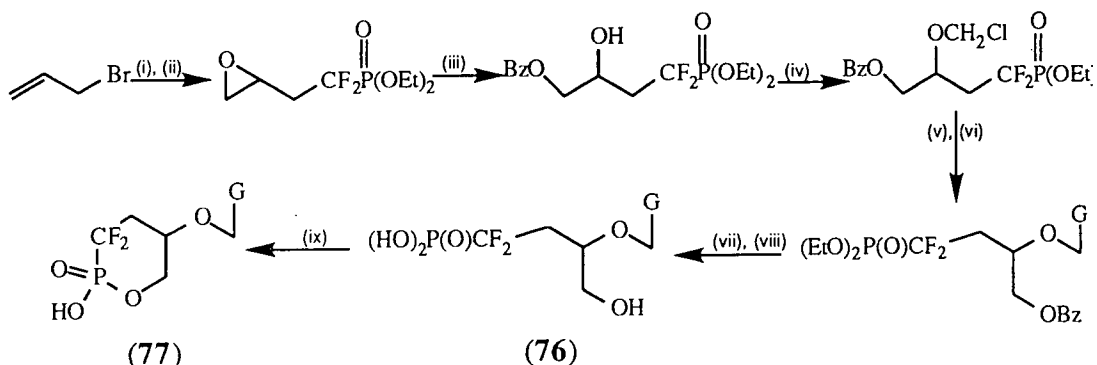

(i) $(\text{EtO})_2\text{P}(\text{O})\text{CF}_2\text{Li}$, -78°C ; (ii) 3-chloroperbenzoic acid, CH_2Cl_2 ; (iii) NaH , THF, PhCH_2OH , Δ ; (iv) $(\text{CO}_2\text{H})_n$, HCl , CH_2Cl_2 ; (v) EtN_3 , 2-amino-6-chloropurine, DMF; (vi) 50% HCOOH ; (vii) $\text{Pd}(\text{OH})_2/\text{C}$, cyclohexene, EtOH ; (viii) trimethylsilylbromide, then H_2O ; (ix) pyridine, dicyclohexylcarbodiimide.

scheme 1.32

A modelling study of α,α -difluoromethylphosphonate as a phosphate mimic in the (phosphonomethoxy)alkylpurine and pyrimidine class of compounds, given [(phosphonomethoxy)ethyl]guanine (**78**) and adenine (**79**) were potent and broad spectrum antiviral phosphonate nucleotide analogues, was undertaken in 1990 by Kim *et al.*,³⁸ who showed that (**80**) (scheme 1.33) was a poor mimic, exhibiting no activity against HIV1 and 2, as well as possessing a significantly lower pK_{a2} (table 1.3).

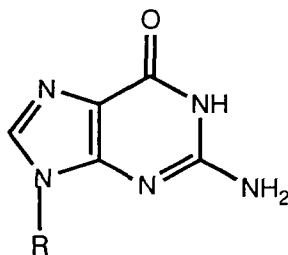

Compound	R	pK _{a2}
78		6.52
80		5.52
81		7.08
82		6.59

table 1.3

This was probably due to the inability of cellular or virally induced kinases to catalyse the conversion of (80) to the diphosphate form.

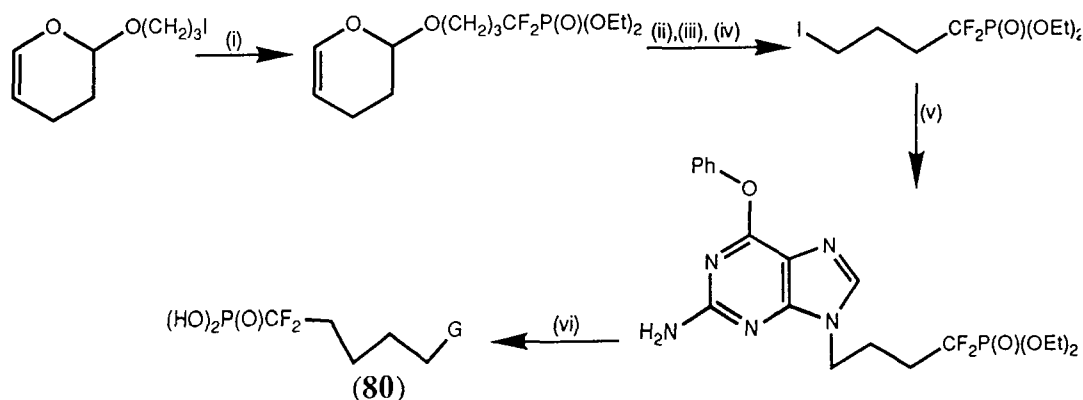

(i) $(\text{EtO})_2\text{P}(\text{O})\text{CF}_2\text{Li}$, THF, HMPA, -78°C ; (ii) 3N HCl; (iii) $\text{CH}_3\text{SO}_2\text{Cl}$, EtN_3 ; (iv) NaI; (v) 2-amino-6-(benzyloxy)purine, NaH; (vi) trimethylsilylbromide, DMF.

scheme 1.33

It has already been demonstrated how dideoxyadenosine (19) is a potent inhibitor of HIV RT (section I.C.3.a). Thus, it occurred to Halazy and Wolff-Kugel to synthesis the carbocyclic phosphonate derivative of this compound,¹²⁶ hoping to simultaneously improve *in vivo* stability of the glycosidic link and bypass the degradation of (19) and (36) by introducing the agent as the non-labile α,α -difluoromethylphosphonate.

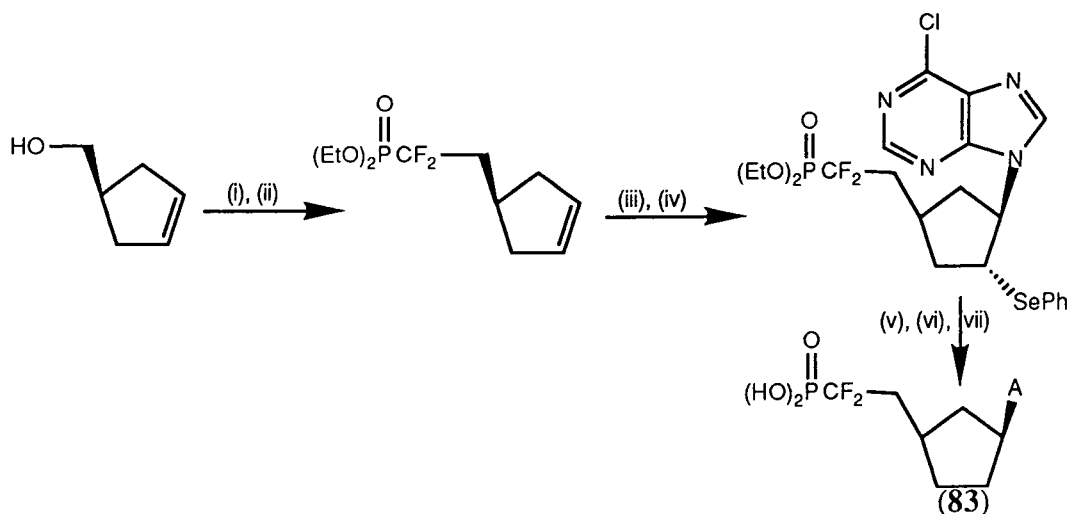

(i) $(\text{TfO})_2\text{O}$, pyridine; (ii) $(\text{EtO})_2\text{P}(\text{O})\text{CF}_2\text{Li}$, -78°C ; (iii) PhSeCl , CH_2Cl_2 ; (iv) 6-chloropurine, CH_3NO_2 , AgBF_4 , CaCO_3 ; (v) $^n\text{Bu}_3\text{SnH}$, AIBN, PhMe , 70°C ; (vi) trimethylsilylbromide, MeCN ; (vii) NH_3 , MeOH .

scheme 1.34

Their strategy involved ring opening of a seleniranium salt by the nucleic acid moiety and yielded (**83**) in under 9%.

I.D.3.b α,β -, β,γ -Fluorophosphonates

Phosphonate derivatives of nucleotides in which the oxygen of a P-O-P link is replaced by a methylene group, have great potential as analogues of many biological phosphates, to probe enzymic pathways. However, it has been found the electron distribution of the phosphonates deviate from the naturally occurring phosphate. Blackburn set out to find a more effective mimic of the phosphate group for probing both enzymic cleavage and binding sites in phosphate systems.¹²⁷

In a simple experiment, similar to Vogel and coworkers,¹²² Blackburn *et al.* synthesised a series of substituted phosphates of the structure (**84a-d**), and studied these with respect to pK_a and divalent metal binding.³⁵

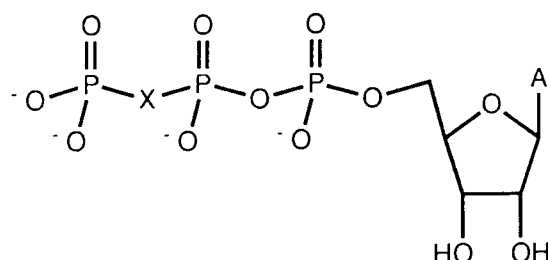

$\text{X}=\text{CH}_2$ (**84a**), $\text{X}=\text{CHF}$ (**84b**), $\text{X}=\text{CF}_2$ (**84c**), $\text{X}=\text{C}\equiv\text{C}$ (**84d**)

It was found that (**84c**) was the most effective isopolar and isosteric mimic to ATP (**74c**) in binding experiments.

On this premise, work was carried out on the enzymic hydrolysis of dinucleotide tetraphosphates, which exist in cells, but with a yet uncertain rôle.²¹ In higher organisms tetraphosphate nucleotides are degraded by asymmetric $\text{P}_\alpha\text{OP}_\beta$ fission to give the nucleotide monophosphate and nucleotide triphosphate, however, eukaryotes possess an

enzyme which produces two equivalents of nucleotide diphosphate by symmetric $P_{\beta}OP_{\beta}$ fission. The phosphonates (**85a-c**) and (**86a-c**) were synthesised (table 1.4) and introduced as substrates into the two systems.¹²⁸

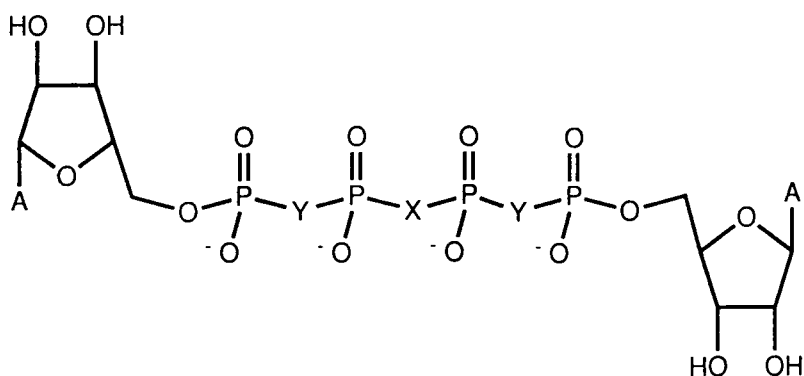

	Substituent	Precursor	Condensing agent
85a	X=CH ₂ , Y=O	84a	Morph-p-Ado
85b	X=CHF, Y=O	84b	Morph-p-Ado
85c	X=CF ₂ , Y=O	84c	Morph-p-Ado
86a	X=O, Y=CH ₂	pCH ₂ pAdo	DCC
86b	X=O, Y=CHF	pCFHpAdo	DCC
86c	X=O, Y=CF ₂	pCF ₂ pAdo	DCC

Morph-p-Ado = adenosine 5'-phosphomorpholidate, DCC = dicyclohexylcarbodiimide
table 1.4

For the asymmetric enzyme, it was found previously using labelled water, that attack occurs at P_{α} ,¹²⁹ therefore substitution of oxygen in the $P_{\beta}OP_{\beta}$ bridge for a methylene substituted moiety should give products still sensitive to hydrolysis (**85a-c**). This was observed, the rate of hydrolysis of the substrate being dependant on the number of hydrogens replaced by more electron withdrawing fluorine, due to the resulting ability of the phosphate leaving group increasing $CF_2 > CFH > CH_2$; the natural product was still the most effective substrate.

In the replacement of the $P_{\alpha}OP_{\beta}$ bridges by methylene groups (**86a-c**) the product should be resistant to hydrolysis by the asymmetric enzyme, this was found to a limited extent, both (**86a**) and (**86b**) giving some breakdown products showing a possible P_{β} attack if in line polar interactions are not unfavourable, this is the case in (**86c**).

In the symmetric cleavage, which can occur only at P_{β} or $P_{\beta'}$ with cleavage of the $P_{\beta}OP_{\beta'}$ the analogues (**85a**) and (**85b**) were found to be inert, while (**85c**) gave a very small amount of product.

This information allowed Blackburn to model the binding site of bis(5'-nucleosidyl)tetraphosphate pyrophosphohydrolyase, the asymmetric fission enzyme (figure 1.7).¹³⁰

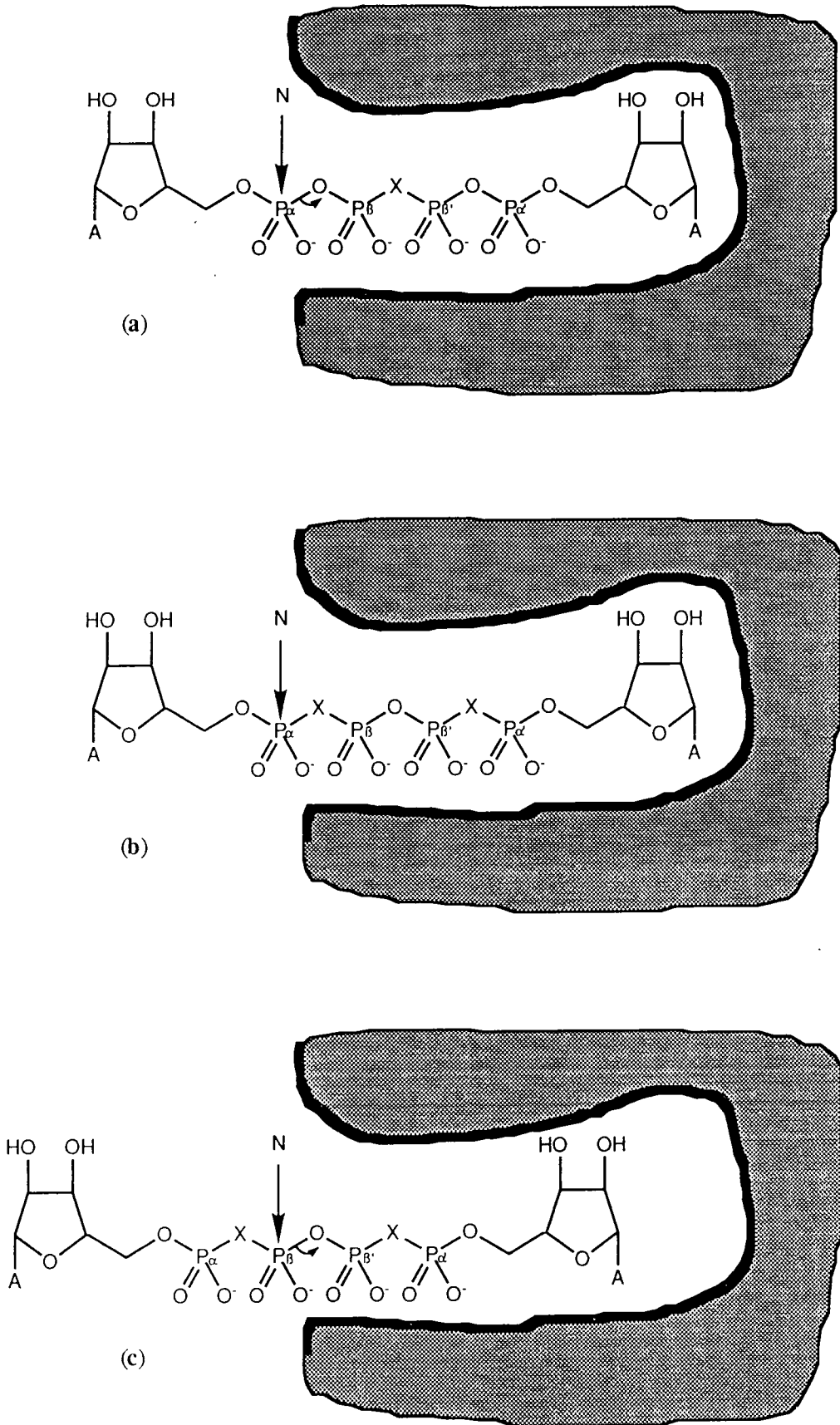
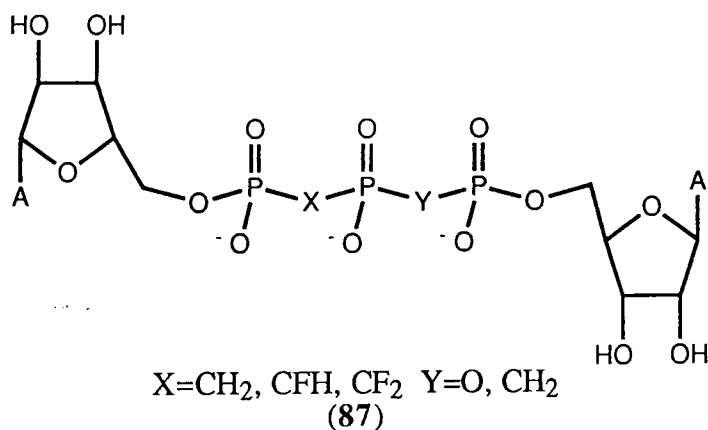

figure 1.7

Blackburn has carried out similar work on the bisadenosyl triphosphates (87),¹³¹ tri- and tetra-(thiophosphonates).¹³²⁻¹³⁴



De Clercq and co-workers synthesised by a similar method to Blackburn the P β OP γ difluoromethylene analogue of AZT (37) as a potential antiviral agent, given that AZT (37) is phosphorylated entirely by cellular enzymes and is active as an inhibitor of RT only as the triphosphate. However, the difluoromethylenephosphonate analogue showed a thirty fold reduction in activity.¹³⁵

I.D.4 Fluoroalkylphosphates

The introduction of a fluoroalkyl group as a hydroxyl mimic has foundation in the similar polarity and hydrogen bonding characteristics of such a group compared to the hydroxyl group. The synthesis of these moieties has been accomplished by a number of procedures, using a modified Yoshikawa process difluoromethylphosphonate esters can be prepared (scheme 1.35) in 2 steps, the mixture of products (88), (89) and (90) being easily separated by chromatography¹³⁶

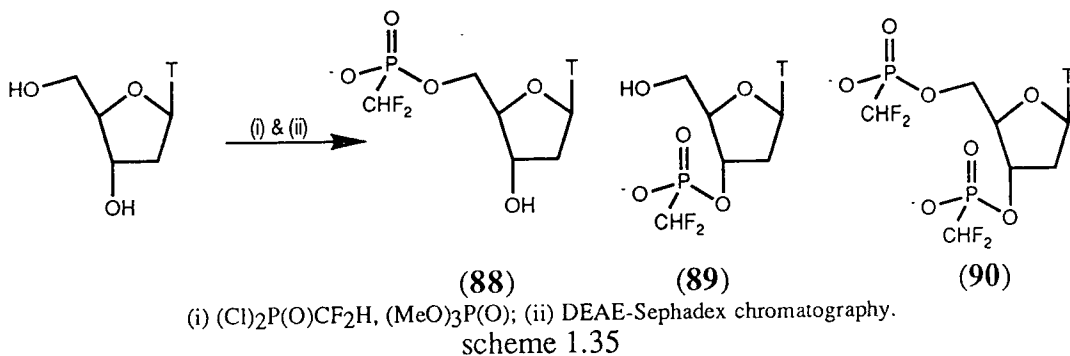

Alternatively Casara *et al.*^{125,137,138} synthesised a range of similar compounds by a facile condensation reaction (scheme 1.36) of the appropriate protected base, the fluorophosphonic acid and dicyclohexylcarbodiimide. Of the analogues prepared the trifluoromethylphosphonate of (37) showed the greatest activity against RT *in vitro*. Work is currently underway to ascertain the mode of action of these non trisphosphorylated active inhibitors.

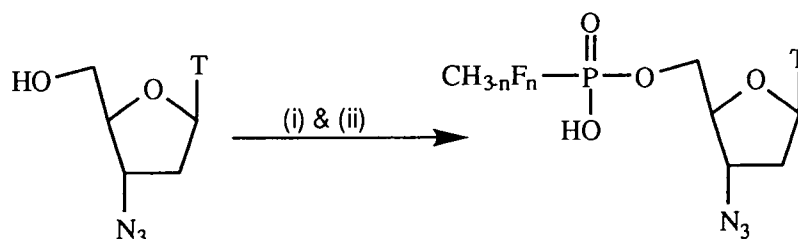

scheme 1.36

I.E. Fluorine Containing Oligonucleotides

I.E.1 Introduction

It has been postulated that oligonucleotides (15-20 nucleotides) complementary to well defined portions of the HIV genome may form a triple helical structure with the proviral DNA, thus preventing transcription of proviral DNA into mRNA, transcription arrest. Alternatively the antisense oligonucleotide may also bind to viral mRNA forming a RNA/DNA hybrid and preventing translation of the viral mRNA, translational arrest. To accomplish this the oligonucleotides must be able to permeate cell membranes and resist premature degradation, this has been achieved by the replacement of the labile phosphate linkage with methyl phosphates and phosphothioates.

I.E.2 Poly(2'-Fluoronucleotides)

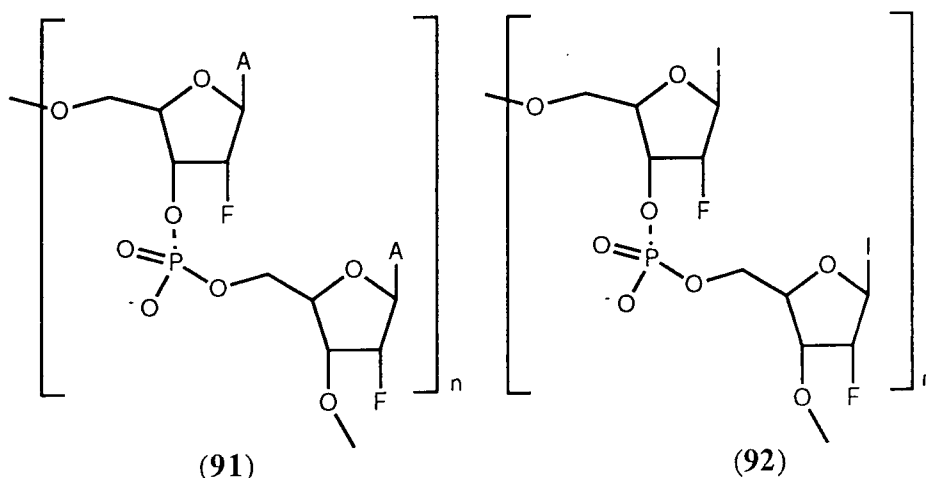

Poly(2'-deoxy-2'-fluoroadenylic acid) (91) has been tested *in vitro* as mRNA in protein synthesising systems. It was found that the modified compound exhibited activity as a messenger and lead to incorporation of radiolabelled lysine into polypeptides, at rate greater than natural poly(riboadenylic acid). Oligonucleotide (91) also exhibited greater resistance to breakdown, *i.e.* was longer-lived.¹³⁹

Poly(2'-deoxy-2'-fluoroinosinic acid) (92), synthesised by polymerisation of 2'-deoxy-2'-fluoroinosine 5'-diphosphate catalysed by a polynucleotide phosphorylase,¹³⁹ is an effective template for RT unlike poly(inosinic acid). It is apparent that

conformational differences induced by the inclusion of the electronegative fluorine atom at C2', affect the polymer structure and hence binding properties which in turn affect biological activity.

I.E.3 Fluoroalkylphosphonate Dimers

Bergstrom and Shum¹⁴⁰ carried out NMR studies utilising ^{19}F NMR, to determine the structure of difluoroalkylphosphonate dimers, obtaining detailed information on the configuration of *P*-deoxy-*P*-(difluoromethyl)thymidylyl(3'-5')thymidine (scheme 1.38).

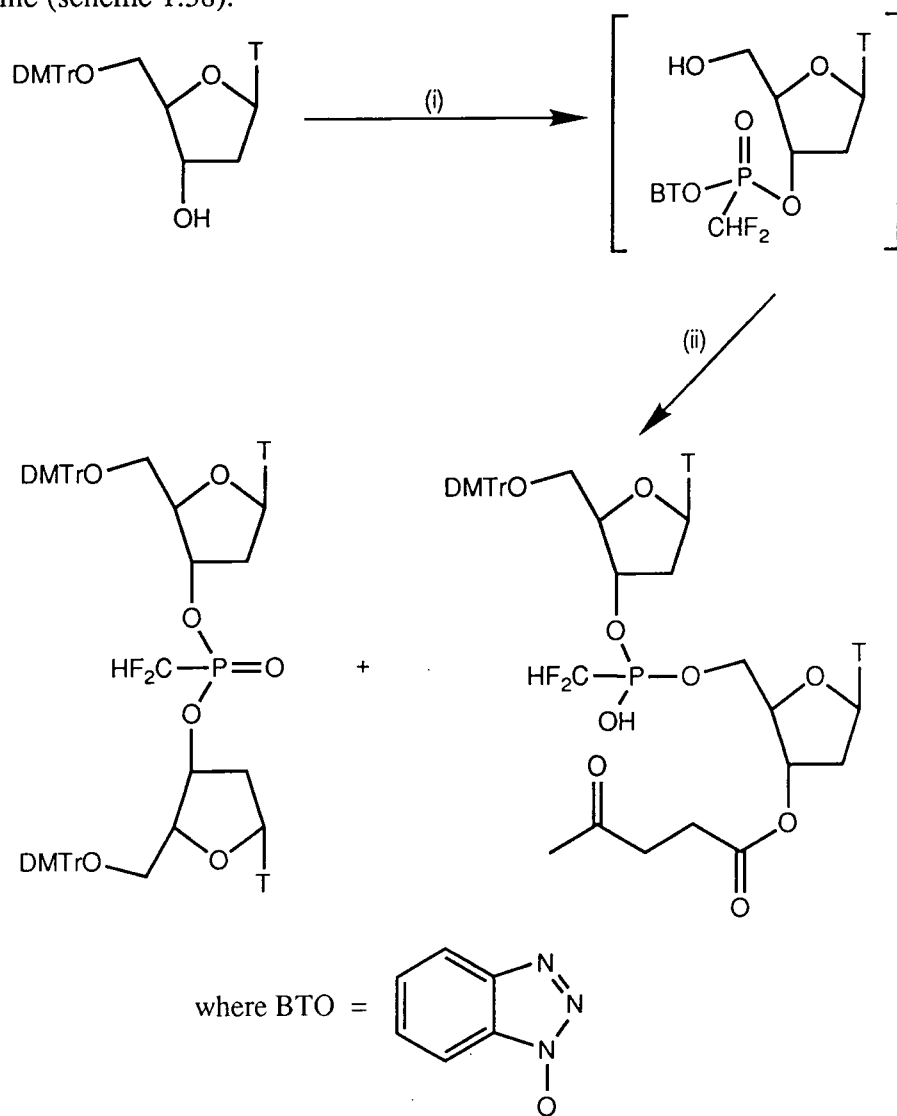

(i) $(\text{BTO})_2\text{P}(\text{O})\text{CF}_2\text{H}$, pyridine; (ii) 5'-O-(4,4'-di-methoxytrityl)-3'-O-levulinylthymidine, pyridine.
scheme 1.38

CHAPTER II

THE (DIETHOXYPHOSPHINYLDIFLUOROMETHYLENE) GROUP

II.A Introduction

The ability of the difluoromethylene unit to mimic an oxygen (section I.B.2), especially in phosphate chemistry,^{35,36} has spawned a wide range of (dihydroxyphosphinyl)difluoromethylene containing compounds. Indeed, the pharmaceutical industry has used the group as a non-labile phosphate group in the area of antiviral chemotherapy.^{135,141} Consequently, routes into (dihydroxyphosphinyl)-difluoromethylene substituted compounds are of significant importance and at present accomplished *via* three processes:

- (i) nucleophilic alkylation reactions utilising organometallic reagents *e.g.* the (dialkoxyphosphinyl)difluoromethylene organometallic reagents or *via* perfluorinated Grignard reagents;
- (ii) by electrophilic fluorination;
- (iii) a single electron transfer process, *e.g.* palladium (0) mediated coupling.

In this section the development and utility of the first two routes will be discussed, with particular attention to the (dialkoxyphosphinyl)difluoromethylene organometallic reagents.

II.A.1 Organometallic Reagents

II.A.1.a (Diethoxyphosphinyl)difluoromethylene Reagents

This subject area has recently been reviewed,³⁰ so only a brief synopsis of these reagents is given.

In 1981 Burton *et al.*¹⁴² developed the cadmium reagent (**93**) the first (diethoxyphosphinyl)difluoromethylene organometallic reagent from (diethoxyphosphinyl)bromodifluoromethane (**94**).¹⁴³ This was later followed by the zinc reagent (**95**)¹⁴⁴ which had the advantage of greater hydrolytic stability. Both (**93**) and (**95**) were capable of nucleophilic displacement reactions (table 2.1) but only at activated carbon sites such as allylic, benzylic, and carbonyl centres.

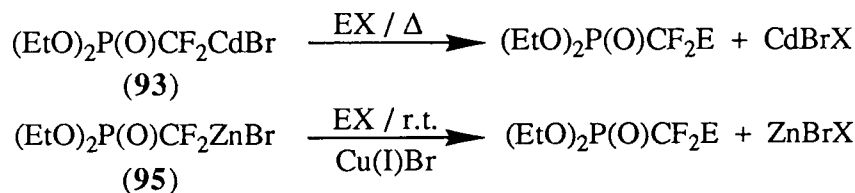

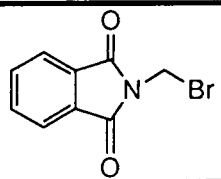
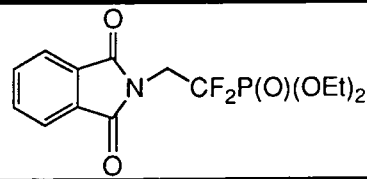
Reagent	EX	Product	Yield
(93)	I ₂	(EtO) ₂ P(O)CF ₂ I	57% ¹⁴²
(93)	SO ₂	(EtO) ₂ P(O)CF ₂ SO ₃ H	90% ^{145,146}
(93)	H ₂ O	(EtO) ₂ P(O)CF ₂ H	100% ¹⁴²
(95)	CH ₂ =CHCH ₂ Br	(EtO) ₂ P(O)CF ₂ CH ₂ CH=CH ₂	47% ¹⁴⁷
(95)			54% ³⁷
(95)	ClC(O)NEt ₂	(EtO) ₂ P(O)CF ₂ C(O)NEt ₂	38% ³⁰

Reactions of (diethoxyphosphinyl)difluoromethylene metal bromides
table 2.1

However, the problem of introducing the (diethoxyphosphinyl)difluoromethylene moiety at unsaturated sites was overcome with the advent of the organolithium reagent (96).¹⁴⁸ The lithium reagent is the most reactive, *i.e.* nucleophilic, of the (diethoxyphosphinyl)difluoromethylene metal reagents. The anion generated is reactive enough to allow substitution in high yields at primary carbon centres (table 2.2). However, the yields obtained for activated carbonyl and allylic sites are not high, and the corresponding zinc reagent (95) is both preferable and more stable in such systems.

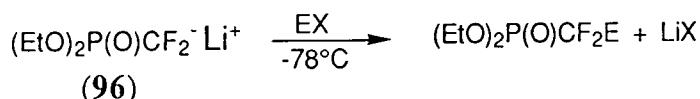

EX	Product	Yield ¹⁴⁸
(CH ₃) ₃ SiCl	(EtO) ₂ P(O)CF ₂ Si(CH ₃) ₃	87%
C ₂ H ₅ Br	(EtO) ₂ P(O)CF ₂ C ₂ H ₅	82%
n-(C ₄ H ₉) ₃ SnCl	(EtO) ₂ P(O)CF ₂ Sn(C ₄ H ₉) ₃	77%
(EtO) ₂ P(O)Cl	(EtO) ₂ P(O)CF ₂ P(O)(EtO) ₂	74%
C ₆ H ₁₃ Br	(EtO) ₂ P(O)CF ₂ C ₆ H ₁₃	66%
C ₆ H ₅ COCl	(EtO) ₂ P(O)CF ₂ COC ₆ H ₅	25%
CH ₂ =CHCH ₂ Br	(EtO) ₂ P(O)CF ₂ CH ₂ CH=CH ₂	23%

Reactions of (diethoxyphosphinyl)difluoromethyl lithium
table 2.2

II.A.1.b Reaction of Perfluoroalkyl Grignard Reagents with Diethyl Chlorophosphate

Cen and Shen¹⁴⁹ found that perfluoroalkyl Grignard reagents generated *in situ* by the reaction of perfluoroalkyl iodides and phenylmagnesium bromide could react with diethyl chlorophosphate, at low temperature leading to the formation of the -CF₂-P bond and affording (diethoxyphosphinyl)perfluoroalkane derivatives (table 2.3).

$$R_F I \xrightarrow{\text{PhMgBr}} R_F \text{MgBr} \xrightarrow{\text{ClP(O)(OEt)}_2} R_F \text{P(O)(OEt)}_2$$

R _F	Yield
n-C ₆ F ₁₃	56%
Cl(CF ₂) ₈	45%
Cl(CF ₂) ₆	58%
Cl(CF ₂) ₄	36%
FO ₂ S(CF ₂) ₂ O(CF ₂) ₄	31%

Reaction of perfluoroalkyl Grignard reagents
table 2.3

II.A.2 Electrophilic Fluorinating Agents

II.A.2.a Perchloryl Fluoride

Perchloryl fluoride²⁹ was one of the first electrophilic fluorinating agents developed, however, fluorination with perchloryl fluoride only proceeds in the presence of anionic substrates; the primary production of a carbanion with a sufficiently strong base is thus a necessary precondition, consequently problems are associated with this method of fluorination *i.e.* it tends to be non-selective.²⁹ McKenna and Shen^{150,151} used perchloryl fluoride to prepare bis(diethoxyphosphinyl)fluoromethane (**97**) and bis(diethoxyphosphinyl)difluoro-methane (**98**), the latter an important antitumour agent,¹⁵² in 33% and 52% respectively (scheme 2.1).

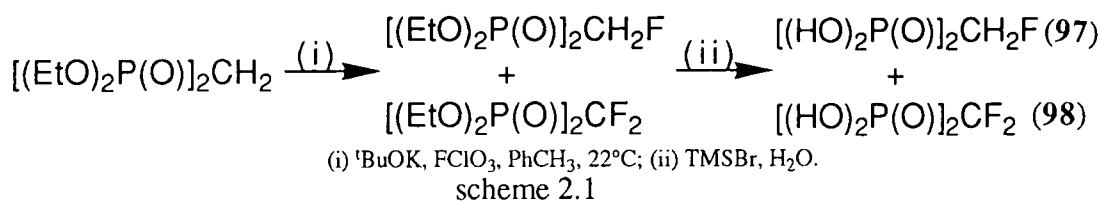

Similarly, Blackburn used perchloryl fluoride in an alternative synthesis of (diethoxyphosphinyl)fluoromethane.¹⁵³

II.A.2.b N-Fluorobenzenesulphonamide (99)

Differding and coworkers¹⁵⁴ extended this methodology by using *N*-fluorobenzenesulphonamide (**99**); one of the next generation electrophilic fluorinating agents, the *N*-fluoro derivatives, which are both cleaner and more selective in their mode

of action than perchloryl fluoride. Differding *et al.* went on to synthesise a range of mono- and di-fluorinated diethoxyphosphinyl derivatives (table 2.4) utilising this reagent.

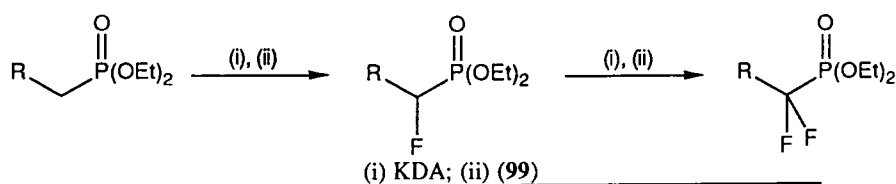

Product	Yield
(EtO) ₂ P(O)CFH ₂	11%
(EtO) ₂ P(O)CFHCH ₃	45%
(EtO) ₂ P(O)CF ₂ CH ₃	66%
(EtO) ₂ P(O)CFHCH ₂ CH ₂ CH ₂ CH ₃	48%
(EtO) ₂ P(O)CF ₂ CH ₂ CH ₂ CH ₂ CH ₃	70%

Reactions with *N*-fluorobenzenesulphonamide
table 2.4

II.B The Chemistry of (Diethoxyphosphinyl)difluoromethylene Zinc Bromide (95)

II.B.1 Reaction of Benzyl Bromide With (95)

The reaction of activated allylic sites with (95) is well documented,¹⁴⁷ unlike the reaction with benzylic sites and although Chambers *et al.*¹⁵⁵ synthesised benzylic (diethoxyphosphinyl)difluoromethylene analogues *via* the organocadmium reagent (93), the literature gives no analogous reaction for the organozinc reagent (95). The reaction between benzyl bromide and (95) was therefore undertaken.

When a freshly prepared solution of (95) in monoglyme was added dropwise to a solution of benzyl bromide in the presence of a catalytic quantity of copper (I) bromide, the product of the reaction was not 2-(diethoxyphosphinyl)-2,2-difluoroethylbenzene, but rather the coupled product bibenzyl (100), verified by ¹H NMR and melting point comparison with commercially available material, and the carbene addition products (*E*)- and (*Z*)-1,2-bis(diethoxyphosphinyl)-1,2-difluoroethene (101a-b), together with (diethoxyphosphinyl)difluoromethane (102).

Attempts to repeat the coupling process of benzyl bromide without (95) but in the presence of copper (I) bromide, a method effective for coupling benzyl bromides,¹⁵⁶ or with only (95), resulted in no formation of bibenzyl, both (95) and the copper (I) salt being necessary.

It was shown that (*E*)- and (*Z*)-1,2-bis(diethoxyphosphinyl)-1,2-difluoroethene (101a-b) could be synthesised by heating (95) in the presence of copper (I) bromide in high yield if no electrophile is available.¹⁵⁷ The conclusion one must draw, therefore, is that the organozinc reagent is not a strong enough nucleophile to react with benzyl

bromide, or the rate of nucleophilic attack is slower than that of the carbene dissociation process. The bibenzyl could be generated by a bromophilic or radical abstraction process involving the (diethoxyphosphinyl)fluoromethylene carbene intermediate (scheme 2.2).

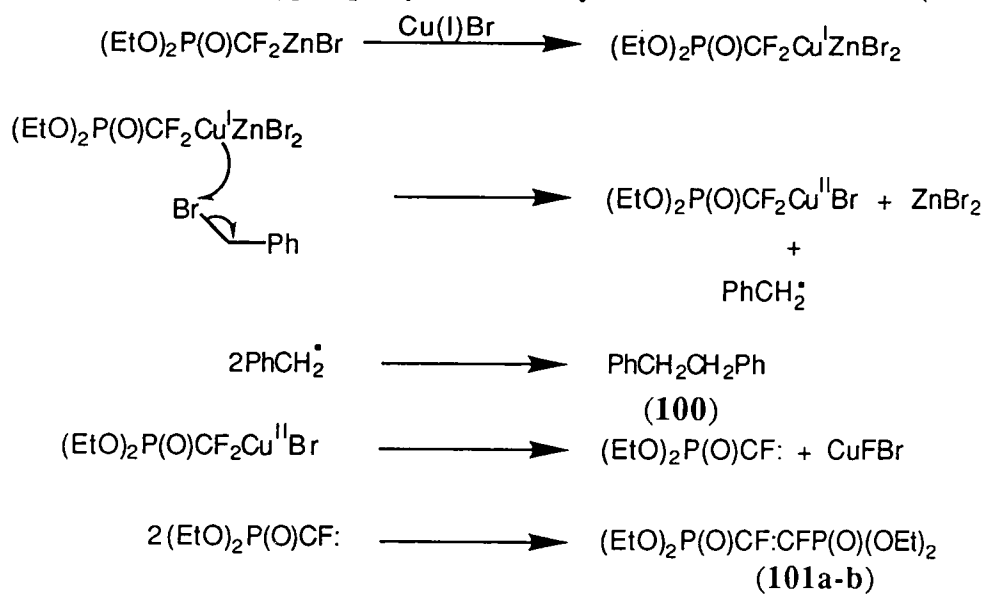

scheme 2.2

II.B.2 Reactions of Allylic Bromides With (95)

II.B.2.a Preparation of 3-Bromocycloalkenes

It has previously been demonstrated by Burton *et al.*¹⁴⁶ that the organozinc reagent (95) reacts with allylic bromides *e.g.* allyl bromide to yield the corresponding allylic (diethoxyphosphinyl)difluoromethylene derivative. It was decided therefore to extend this methodology, to synthesise a range of cyclic alkenyl (diethoxyphosphinyl)difluoromethylene compounds. To facilitate this process it was first necessary to prepare the cycloalkenyl bromides.

The bromination of allylic protons by the use of *N*-bromosuccinimide is a standard laboratory reaction and following the work of Hatch and Bachmann¹⁵⁷ 3-bromo derivatives of cyclopentene (103), cyclohexene (104) and cycloheptene (105) were prepared (table 2.5).

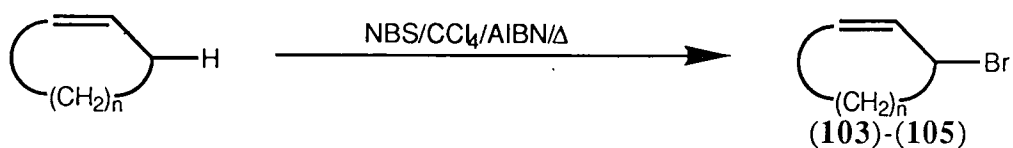

Compound	n	Yield
(103)	2	35%
(104)	3	52%
(105)	4	41%

Yields of cyclic 3-bromoalkenes
table 2.5

The reaction was not as simple as indicated in the literature due to the instability of the 3-bromocycloalkenes, which decompose at room temperature. Indeed this fact was reflected in the yields; isolation of the compounds required a distillation *in vacuo* at elevated temperature resulting in significant decomposition. The 3-bromocycloalkenes were all colourless oils which were subsequently stored below -10°C .

II.B.2.b The Reaction of Bromocycloalkenes With (95)

From the 3-bromocycloalkenes we accomplished the syntheses of the (diethoxyphosphinyl)difluoromethylene derivatives by the dropwise addition of the organozinc reagent (95) in monoglyme to the 3-bromoalkenes (103)-(105) in the presence of a copper (I) bromide catalyst. Various conditions were attempted to optimise yields, a clear pattern emerging between the stability of the 3-bromoalkene and the yield of the desired products (table 2.6).

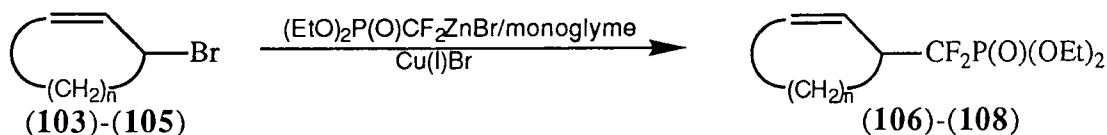



Compound	n	Temperature ($^{\circ}\text{C}$)	Yield
(106)	2	20	0%
(106)	2	-10 to 20	5%
(106)	2	-78 to 20	9%
(107)	3	-78 to 20	51%
(107)	3	-78 to 86	65%
(108)	4	-78 to 20	30%
(108)	4	-78 to 86	51%

Effect of temperature on the yield of 3-[(diethoxyphosphinyl)difluoromethyl]cycloalkenes
table 2.6

The reaction of 3-bromocyclopentene with (95), to give 3-[(diethoxyphosphinyl)difluoromethyl]cyclopentene (106), was hampered by the extreme instability of the bromoalkene, to such an extent that no product could be detected when the reaction was carried out at room temperature. This could have been due to the extremely exothermic nature of the reaction, gas evolution and a rapid darkening in colour accompanied the reaction at room temperature. Thus, the temperature rise could have caused auto-decomposition of 3-bromocyclopentene (103), *via* elimination of hydrogen bromide. Indeed, ease of elimination would be expected to follow the trend; (103) > (105) > (104) (assuming an equatorial disposition for bromine). The rigid almost planar conformation in the strained five-membered ring leaving bromine well set up for coplanar *anti*-elimination of hydrogen bromide, and the cycloheptenyl ring with a greater degree of flexibility in the ring would be expected to be less stable than the six membered ring.

The degree of instability in (103) could be contrasted with the results found in the reactions of the bromides (104) and (105). The effect of temperature became less important in these systems, indeed 3-bromocycloheptene give an increased yield upon heating to reflux temperature. Once again this phenomenon could be explained in terms of the stability of the bromides, both 3-bromocyclohexene and 3-bromocycloheptene were quite stable at room temperature for a number of days, the conformational geometries of the molecules moving away from the ideal fixed *anti*-regiochemistry for elimination held in the cyclopentenyl ring.

The 3-[(diethoxyphosphinyl)difluoromethyl]cycloalkenes (106)-(108) could be readily identified by the presence of the heavily coupled ring proton geminal to the (diethoxyphosphinyl)difluoromethylene moiety, which, occurred in all cases at $\approx 2.97\text{ppm}^{147}$ and a characteristic ^{19}F NMR shift from the precursor bromide (94) (table 2.7). However, the stereochemical assignment of the products proved to be a more difficult task (section II.B.2.d).

Compound	Shift (ppm)	Coupling Constant (Hz)
(EtO) ₂ P(O)CF ₂ Br (94)	-60.63	$^2J_{\text{FP}} = 93.1$
 (106)	-115.345	$^2J_{\text{FF}} = 301.3$ $^2J_{\text{FP}} = 113.2$ $^3J_{\text{HF}} = 17.4$
 (107)	-114.419	$^2J_{\text{FF}} = 300.0$ $^2J_{\text{FP}} = 108.6$ $^3J_{\text{HF}} = 18.6$
 (108)	-109.280	$^2J_{\text{HF}} = 298.4$ $^2J_{\text{FP}} = 111.8$ $^3J_{\text{HF}} = 21.4$

^{19}F NMR shifts and coupling for 3-[(diethoxyphosphinyl)difluoromethyl]cycloalkenes
Table 2.7

II.B.2.c Reaction Mechanism of Allylic and Propargylic Halides With (95)

$\text{S}_{\text{N}}2'$ mechanism



S_N2 mechanism

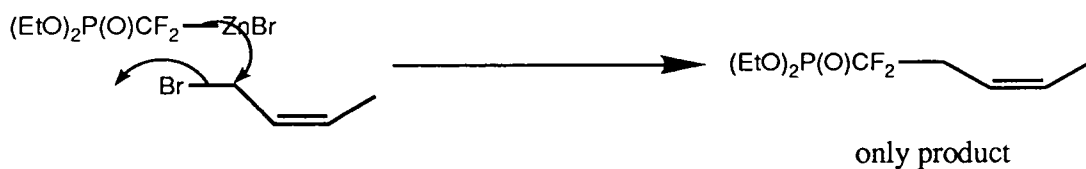

scheme 2.3

The mechanism for the reaction appears to be predominantly *via* a S_N2'/S_N2 type process (scheme 2.3) dependant upon which allylic site is least sterically hindered,^{147,155} though evidence that a competing single electron transfer (SET) process is also operating can not be ruled out. Indeed, evidence for the SET process comes from the presence of carbene addition side products, such as the vinylic species 1,2-bis(diethoxyphosphinyl)-1,2-difluoroethene (**101**), derived from (diethoxyphosphinyl)fluoromethylenecarbene¹⁵⁷ (**109**) dimerisation or a (diethoxyphosphinyl)difluoromethylene copper carbenoid.

The rôle of the copper (I) halides as a means of activation for the nucleophilic attack of (**95**) on 3-bromoalkenes has precedent, a copper (III) allyl complex intermediate (**110**) proposed for a number of copper mediated reactions. However, Sprague later dismissed this intermediate in the reaction of (**95**) with allylic bromides,¹⁵⁹ rather activation came from the formation of a very reactive (diethoxyphosphinyl)difluoromethylene copper species (**111**), which could be isolated in DMF.¹⁶⁰



II.B.2.d Stereochemistry for the Reaction of Allylic Halides With (**95**)

The stereochemical course of the reaction of (**95**) with 3-bromocycloalkenes was determined by ^1H NMR studies, utilising both conventional one dimensional spectra, decoupling experiments as well as two dimensional homonuclear correlation spectroscopy (COSY).

The narrow band decoupling of the cyclopentene derivative (**106**) allowed unambiguous assignments of which protons were coupled to each other, and their relative positions around the cyclopentene ring (figure 2.1).

However, the unambiguous assignment of the position of the (diethoxyphosphinyl)difluoromethylene group could not be made due to the lack of axial/equatorial positions in such systems.

The conformation adopted in cyclohexene systems has been shown experimentally¹⁶¹ and by calculation to be a twist chair, with the methylene groups adjacent the double bond termed as pseudoaxial or pseudoequatorial. For the

cyclohexenyl derivative (**107**) a combination of decoupling and two dimensional ^1H COSY allowed the assignment of the relative positions of the protons around the ring (figure 2.2).

The COSY spectrum shows that:

- (i) H_1 is coupled strongly to H_3 and H_5 or H_6 ;
- (ii) H_2 is coupled strongly to H_4 ;
- (iii) H_3 is coupled strongly to H_1 and H_5 or H_6 .

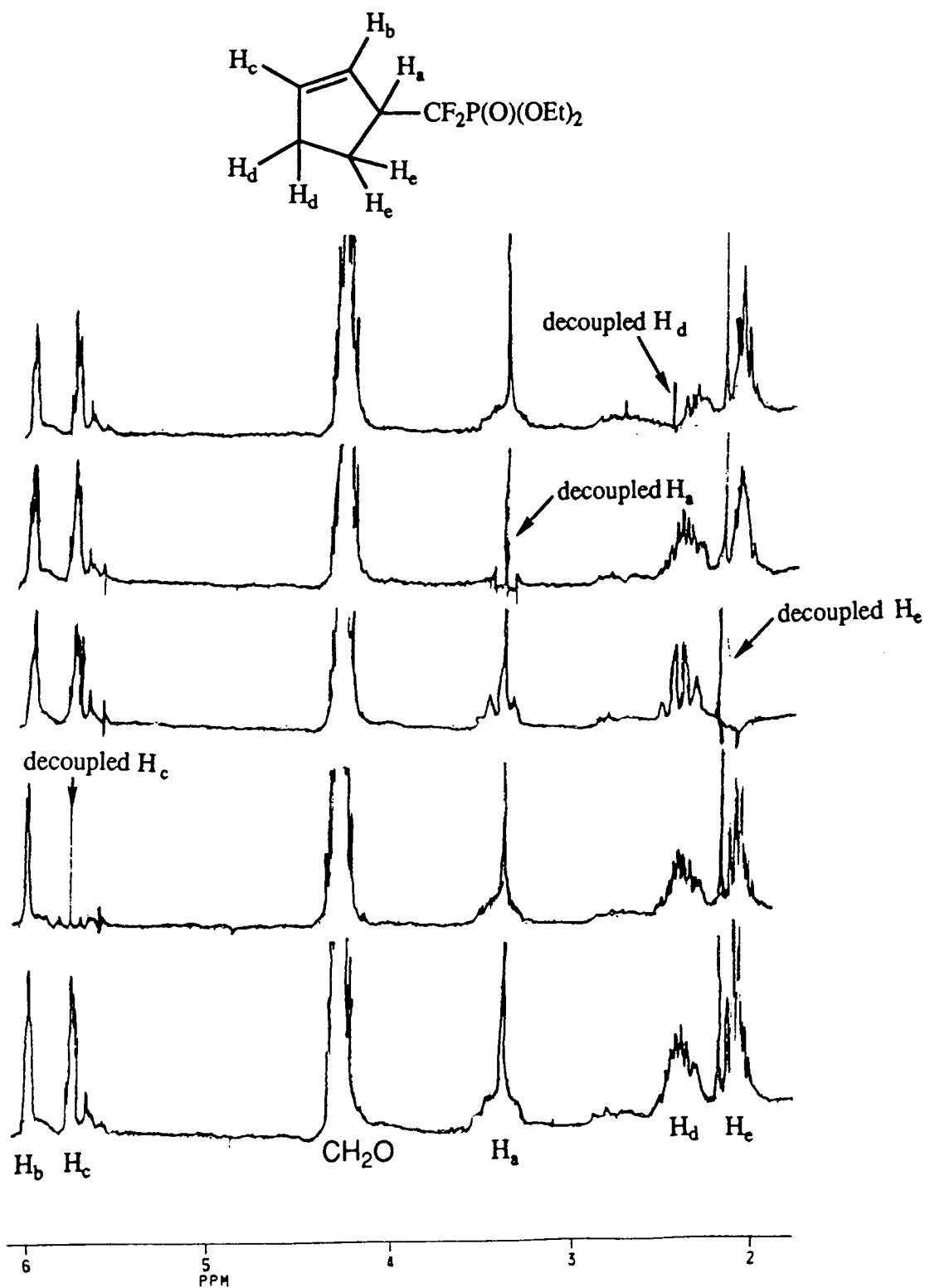

figure 2.1

NCP PCF2H1 data are in 1110 H1
RUN ON Sep 3 92
SOLVENT CDCl3
OBSERVE H1

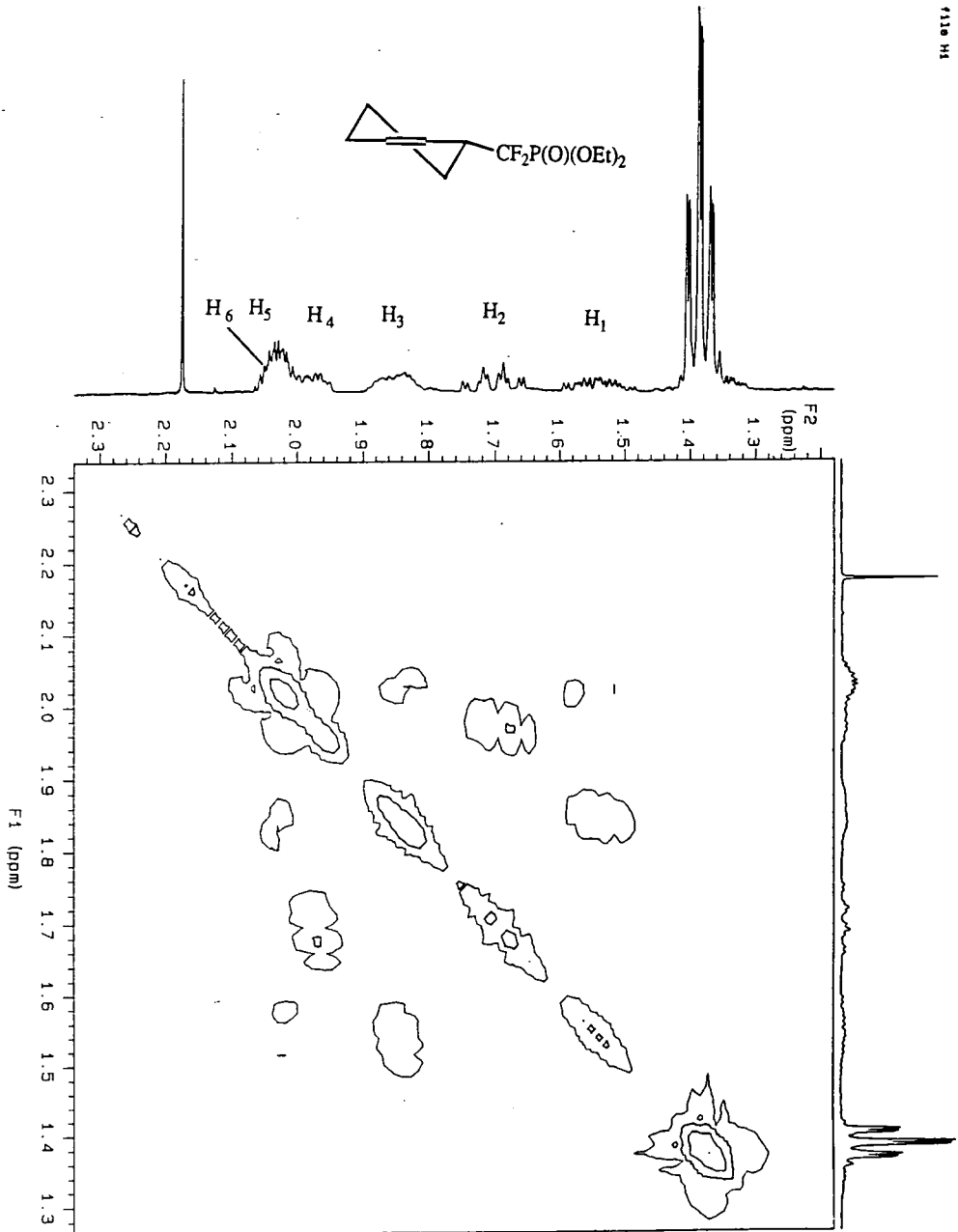

figure 2.2

Subsequent narrow band decoupling of the proton geminal to the (diethoxyphosphinyl)difluoromethylene group (H_7) showed that H_7 coupled to H_9 and H_2 (figure 2.3).

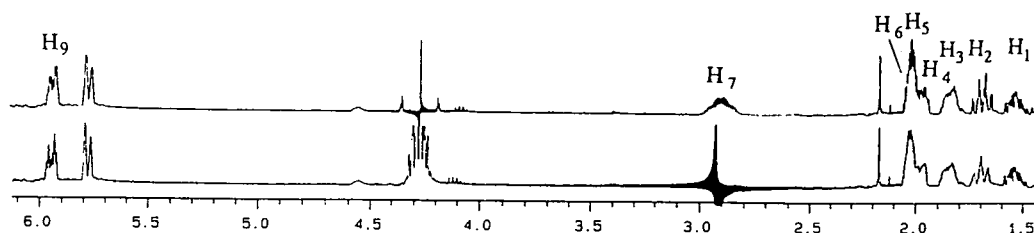

figure 2.3

Assignment of the relative positions of the protons around the cyclohexenyl ring could now be made. Axial protons generally resonate at higher field than equatorial protons, therefore, it can be assumed H_1 and H_2 are axial and must adopt the positions H_f , H_d or H_b in figure 2.4. However, H_1 and H_2 do not show a characteristically large axial-axial coupling constant and H_2 is coupled to H_7 , therefore, H_2 must be H_b and H_1 is H_f . Since H_2 couples strongly only to H_4 it can be deduced that H_4 is the geminal proton H_c . Given that H_3 resonates at a higher field than either H_5 or H_6 then it can be assigned to H_d . However, this leaves H_5 and H_6 which can not be unambiguously assigned due to significant overlap, they must be either H_e or H_g .

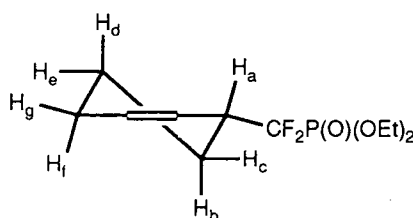

figure 2.4

The elucidation of the stereochemical position of the (diethoxyphosphinyl)-difluoromethylene group could then be determined from the coupling constants of the 1H NMR spectrum of (**107**) (figure 2.5).

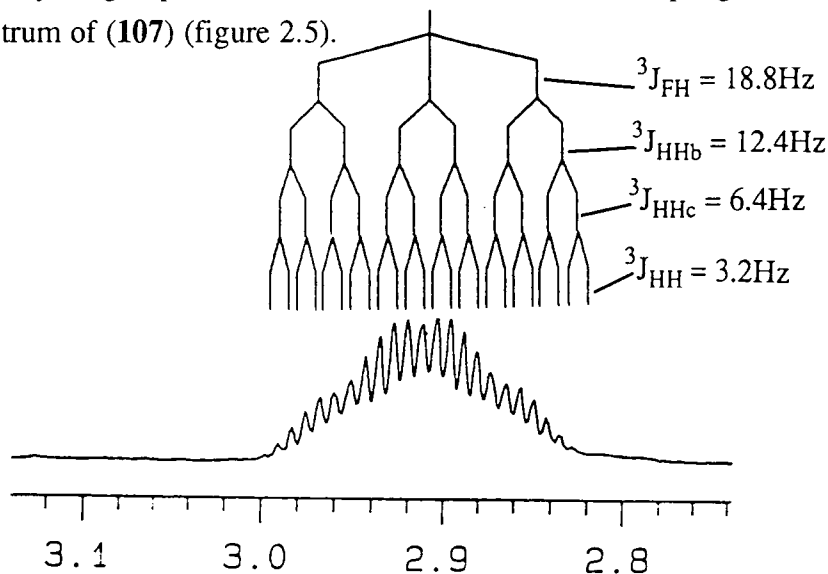

figure 2.5

The $^3J_{\text{HaHb}}$ coupling constant would be expected to be of the order of 6-14Hz for an axial-axial interaction, *cf.* 12.4Hz, the axial-equatorial relationship between H_a and H_c should give a coupling in the order of 0-5Hz, $^3J_{\text{HaHc}} = 6.4\text{Hz}$ and the vicinal coupling to the alkenyl proton at $^3J_{\text{HaH}} = 3.2\text{Hz}$ compares favourably with literature values of between 4-10Hz.¹⁶² Thus the relative position of the (diethoxyphosphinyl)difluoromethylene group is pseudoequatorial, this conformer minimising unfavourable 1,3-diaxial interactions between the axial hydrogen and the bulky (diethoxyphosphinyl)-difluoromethylene group.

No attempt was made to define the stereochemistry of the (diethoxyphosphinyl)difluoromethylene group for (108).

II.B.3 Attempted Palladium (0) Catalysed Reactions of (95) with Allylic Acetates and Phenyl Allyl Ethers

Trost and coworkers¹⁶³ have shown that allylic alcohols, allyl phenyl ethers, and allyl carboxylates can be efficiently, and with a high degree of chemoselectivity, converted by a palladium (0) catalysed allylic substitution reaction to give compounds derived from soft nucleophiles, *e.g.* malonate, or bis(benzenesulphonyl)methane (scheme 2.4).

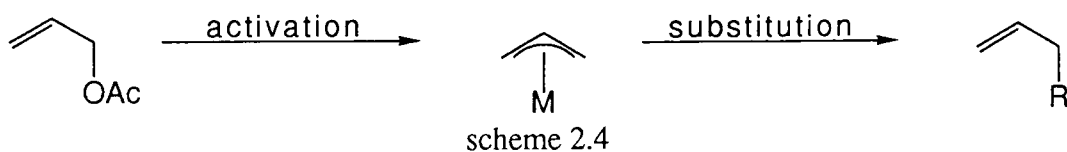

This methodology, based on carboxylates and phenyl allyl ethers, has advantages over conventional alkylation reactions, in that:

- (i) The carboxylates are more readily available in stereodefined form, necessary for asymmetric synthesis;
- (ii) The carboxylates and ethers are more stable in comparison to the equivalent allylic halides.

Given these advantages, and the fact elimination reactions frequently compete with substitution reactions, particularly when cyclic allylic halides are used (section II.B.1), the palladium (0) catalysed route should provide a greater degree of chemoselective control, especially for the problematic cyclopentenyl systems.

II.B.3.a The Attempted Palladium (0) Catalysed Reaction of (95) with *Cis*-Acetoxy-5-carbomethoxy-1-cyclohexene (112)

Before any attempt to react (95) with allylic acetates in the presence of a palladium (0) catalyst, *cis*-acetoxy-5-carbomethoxy-1-cyclohexene (112) had to be synthesised. This was achieved *via* a five step synthesis (scheme 2.5).¹⁶³⁻¹⁶⁵

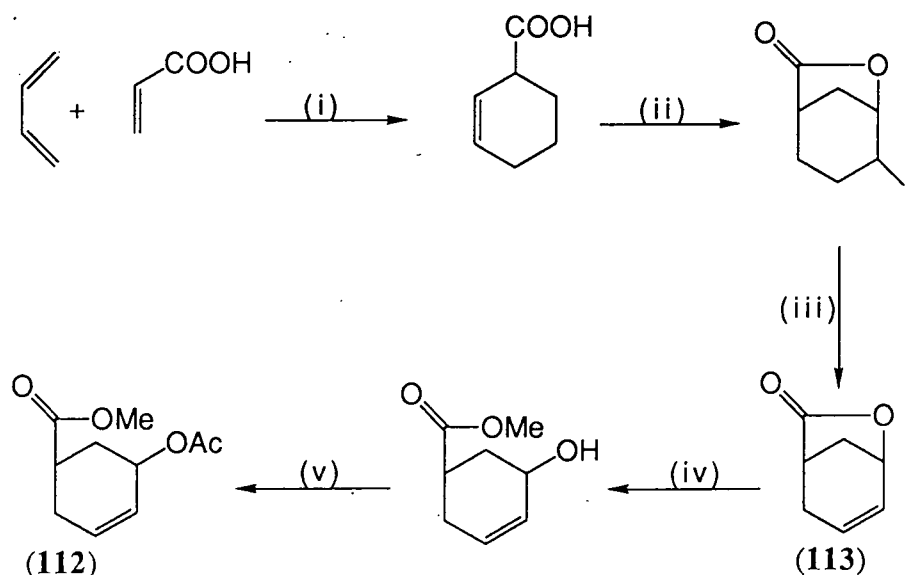

(i) 160°C, 0.5hr; (ii) KI, NaHCO₃, I₂, H₂O; (iii) AgOAc, DMSO, 130°C; (iv) MeONa, MeOH;
(v) AcOCl, pyridine, CH₂Cl₂.
scheme 2.5

Dehydroiodination was achieved most successfully by the use of silver acetate,¹⁶⁵ in yields up to 84%, the silver being easily removed as the insoluble chloride and the reduced metal by filtration. Initially 1,5-diazabicyclo[5.4.0]undecane-5 (DBU) a very hindered base, was used to dehydroiodinate the iodolactone but the presence of iodine reduced yields, the maximum yield obtained being only 25%. The low yield was due to the reaction of the DBU with iodine to form the iodide salt, which was insoluble in benzene, effectively removing the DBU from the reaction.

The ring opening of 6-oxabicyclo[3.2.1]octen-5-one (113) with a catalytic amount of sodium methoxide in methanol yielded 3-hydroxy-5-carbomethoxy-1-cyclohexene in a predominantly *cis*-conformation in a yield of 65% (figure 2.6).

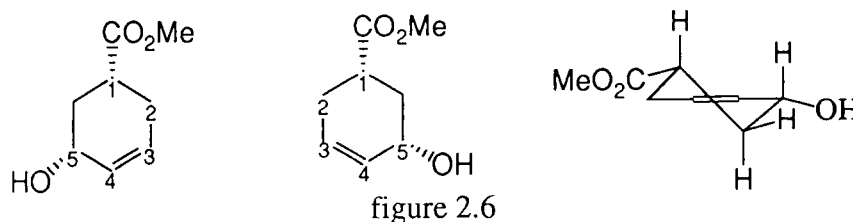

figure 2.6

Analysis of the product by g.c. showed contamination with 4.5% of the *trans*-isomer, arising from ester epimerisation during methanolysis. The final step to (112) was accomplished in a 53% yield by acetylation of the alcohol by acetyl chloride in the presence of pyridine, to remove the hydrogen chloride generated.

The purified allyl acetate (**112**) was taken and stirred in anhydrous oxolane, THF, with a catalytic amount of the palladium (0) complex, tetrakis(triphenylphosphine) palladium, for one hour to generate the symmetrical π -allyl complex, the symmetry of the species removing problems arising from differentiation of both stereo- and regio-isomers.

Into this solution an excess of (**95**) in monoglyme was then added, and the mixture heated to reflux for one day. The reaction was monitored by both high field ^{19}F NMR and thin layer chromatography, TLC, each showing no reaction had taken place. Prolonged heating for a further two days, again, showed no sign of reaction.

II.B.3.b The Attempted Palladium (0) Catalysed Reaction of (95) with 3-Phenoxy-cyclopentene (114)

3-Phenoxy-cyclopentene (**114**) is capable of undergoing nucleophilic alkylation reactions in the presence of a palladium(0) catalyst.¹⁶⁶ It was thought that this system could be used as a route to a five-membered (diethoxyphosphinyl)difluoromethylene derivative.

The thermally stable compound (**114**), *cf.* 3-bromocyclopentene, was synthesised, by a route shown in scheme 2.6.

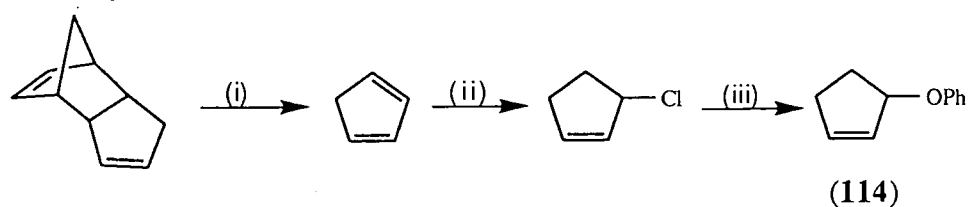

(i) 160°C; (ii) HCl(g), -69°C; (iii) PhOH, NaOH, DMF, H₂O
scheme 2.6

The cracking of dicyclopentadiene provided cyclopentadiene which was used immediately in the next stage of the reaction, due to its tendency to polymerise at room temperature. The diene was collected in a solid carbon dioxide-acetone cooled receiver flask, in which the next step of the synthesis could be carried out.

The conversion of the diene to 3-chlorocyclopentene¹⁶⁷ was accomplished by the bubbling of a rapid stream of dry hydrogen chloride into the cooled flask with vigorous stirring, the temperature never being allowed to rise above 0°C. Polyaddition did not occur and the 3-chlorocyclopentene was used without further purification.

The phenyl allyl ether was then generated by an $\text{S}_{\text{N}}2$ or $\text{S}_{\text{N}}2'$ displacement of the chloro group by the phenoxide ion aided by the use of the polar solvent media, *N,N*-dimethylformamide-water. The yield obtained was low at 11%, but acceptable given the literature yield of 10%.¹⁶⁸

The purified phenyl allyl ether (**114**) was stirred with the palladium (0) catalyst in THF for one hour, under nitrogen, a colour change being observed from pale green to dark red. An excess of (**95**), in monoglyme, was then added and the mixture refluxed for one day.

^{19}F NMR and TLC showed no generation of the expected product 3-[(diethoxyphosphinyl)difluoromethyl]cyclopentene (**106**).

II.B.3.c The Attempted Palladium (0) Catalysed Reaction of (95) with 6-Oxabicyclo[3.2.1]octen-5-one (113)

It has been reported by Trost *et al.*¹⁶³ that the lactone (**113**) proves to be an excellent substrate for palladium (0) catalysed alkylation reactions, and provides a synthetically simpler target than *cis*-3-acetoxy-5-carbomethoxycyclohexene (**112**).

Thus, lactone (**113**) was stirred in THF with a catalytic amount of tetrakis(triphenylphosphine) palladium for one hour, under nitrogen. An excess of the organozinc reagent (**95**) was then added, and the reaction mixture heated to reflux.

^{19}F NMR and TLC showed no conversion to product.

II.B.3.d Conclusion

It can be concluded that from the three systems tried *i.e.* *cis*-3-acetoxy-5-carbomethoxycyclohexene, 3-phenoxy-cyclopentene, and 6-oxabicyclo[3.2.1]octen-5-one are all inert towards alkylation by the (diethoxyphosphinyl)difluoromethylene group under the normal conditions *viz.* oxolane heated to reflux. This is not without precedent, in some systems boiling dimethylsulphoxide having to be used as the solvent *e.g.* (**115**) gives a mixture of (**116**) and (**117**) in 50% yield.¹⁶⁹

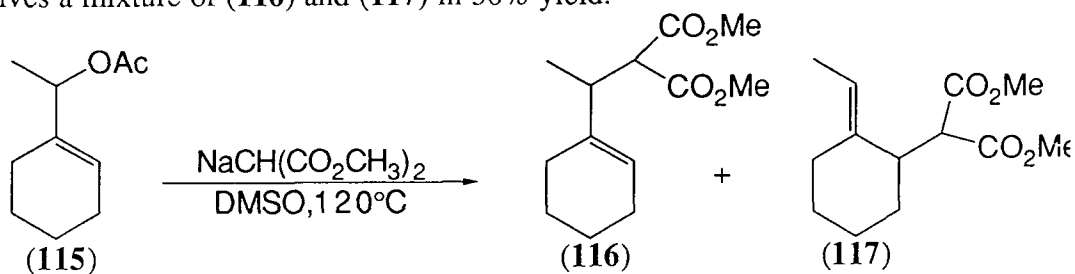

Burton *et al.*¹⁷⁰ also encountered difficulty in introducing a (diethoxyphosphinyl)difluoromethylene group into internal alkenes using palladium (0) catalysis with (diethoxyphosphinyl)difluoroiodomethane (**118**).

II.B.4 General Conclusion

The (diethoxyphosphinyl)difluoromethylene zinc bromide reagent gives high yields with allylic systems, and is the reagent of choice for substitution of allylic bromides, the yields only being dependant on the stability of the allyl halides.

The mechanism of the substitution reaction is unclear, evidence pointing at a $\text{S}_{\text{N}}2$ or $\text{S}_{\text{N}}2'$ type mechanism, but side products are indicative of a carbene or carbenoid intermediate. It is however known that it does not progress *via* an addition/substitution

mechanism. The actual mechanism probably lies in between the two extremes mentioned.

II.C The Chemistry of (Diethoxyphosphinyl)difluoromethylene Lithium (96)

As indicated previously Obayashi *et al.*^{148,171} carried out significant research into the uses of the organolithium reagent (96). A study was undertaken to first, evaluate the reagent, and then extend its synthetic utility.

II.C.1 Generation of the Lithium Salt (96)

The (diethoxyphosphinyl)difluoromethylene anion is generated at temperatures below -78°C (scheme 2.7) due to its extreme instability *via* dissociation.³⁰

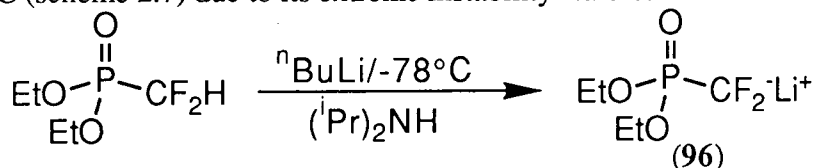

scheme 2.7

Thus, the anion (96) was generated, under a standard set of conditions, and quenched with deuterium oxide to generate (diethoxyphosphinyl)difluorodeuteromethane (119) to determine the maximum conversion to the anion (96). The ratio of (119) to (diethoxyphosphinyl)difluoromethane (102) could then be found by measurement of peak areas in the ^{19}F NMR spectrum (figure 2.7). The integration of the peak areas showed that the ratio of (119) to (102) was 2:1 indicative of a 66% conversion to the anion (96).

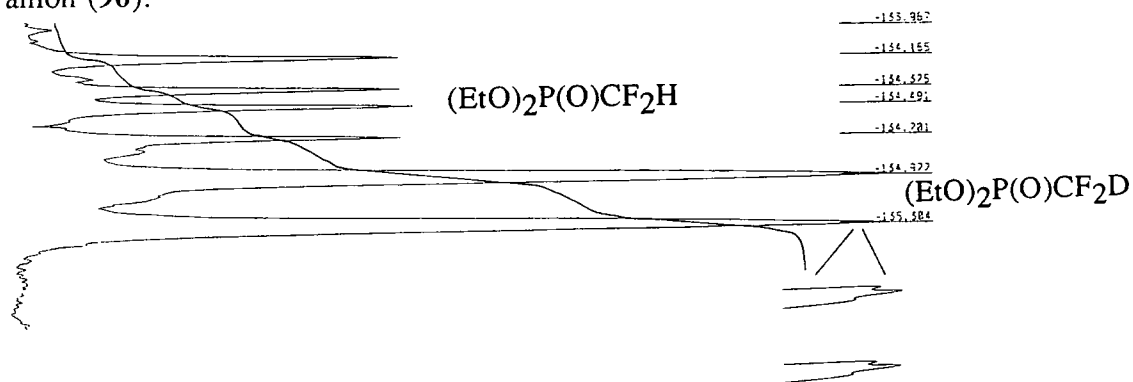

figure 2.7

The fluorine atoms in (diethoxyphosphinyl)difluoromethane (102) were split by phosphorus ($^2J_{\text{FP}}=96.03\text{Hz}$) and the hydrogen atom ($^2J_{\text{FH}}=46.60\text{Hz}$), nuclei with a nuclear spin (I) of $1/2$ hence a doublet of doublets centred at 134.433ppm was observed, while (diethoxyphosphinyl)difluorodeuteromethane with a deuterium atom, which has a nuclear spin of 1 , gave a doublet from phosphorus ($^2J_{\text{FP}}=80.00\text{Hz}$), of triplets from deuterium ($^2J_{\text{FD}}=6.59\text{Hz}$) centred at 135.141ppm . However, the deuterium coupling is

only ≈ 0.152 that of hydrogen coupling and further expansion was needed to resolve the triplets.



II.C.2 The Reaction of (96) with Halides

Almost all previous work utilising the lithium reagent involves halide displacement on a suitable substrate.^{38,137} Experiments were therefore carried out with primary, secondary and benzylic halides.

II.C.2.a Saturated Halides

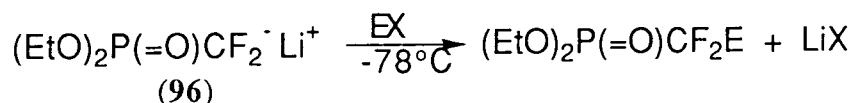
Burton had shown that the organozinc reagent (95) could not effect the displacement of halide from saturated alkyl halides with the exception of the most reactive to S_N2 substitution, methyl iodide,³⁰ this contrasts with our findings for the lithium reagent.



EX	Product	Yield
CH ₃ I	(EtO) ₂ P(O)CF ₂ CH ₃	80%
C ₂ H ₅ I	(EtO) ₂ P(O)CF ₂ C ₂ H ₅	47%
<i>p</i> -NO ₂ C ₆ H ₄ CH ₂ CH ₂ Br	<i>p</i> -NO ₂ C ₆ H ₄ CH ₂ CH ₂ Br	0%
(CH ₃) ₂ CHBr	(CH ₃) ₂ CHBr	0%
		2% [†]

Reaction of (diethoxyphosphinyl)difluoromethylene lithium (96) with saturated alkyl halides table 2.7

The reactivity of (diethoxyphosphinyl)difluoromethylene lithium (96) at saturated carbon centres was:

substitution of primary halides > secondary halides.

This is consistent with a typical S_N2 process where branching at either the α or β carbon decreases the rate of the S_N2 mechanism, due almost certainly to steric factors.¹⁷²

The anomalous result for the primary halide *p*-nitrobromoethylbenzene was perhaps due to the lability of the hydrogen atom at the benzylic site, which the lithium salt (96) may have abstracted in preference to the bromine atom, *i.e.* the elimination process competing against the nucleophilic substitution of bromine.

[†] Yield determined by ¹⁹F NMR

II.C.2.b Benzylic and Allylic Halides

The methodology used for the following reactions is identical to that described in the previous section (section II.C.1).

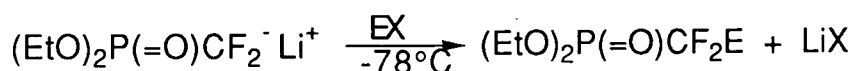

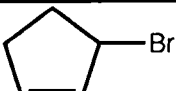
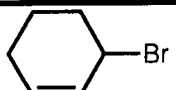
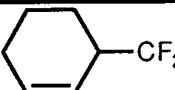
EX	Product	Yield
$\text{C}_6\text{H}_5\text{CHBrCH}_3$	$(\text{EtO})_2\text{P}(=\text{O})\text{CF}_2\text{CH}(\text{CH}_3)\text{C}_6\text{H}_5$ (120)	30%
$\text{CH}_2=\text{CHCH}_2\text{Br}$	$(\text{EtO})_2\text{P}(=\text{O})\text{CF}_2\text{CH}_2\text{CH}=\text{CH}_2$ (121)	66%
	$(\text{EtO})_2\text{P}(=\text{O})\text{CF}_2\text{P}(=\text{O})(\text{OEt})_2$ (122)	18%
	 $\text{CF}_2\text{P}(=\text{O})(\text{OEt})_2$ (107)	51%

Reaction of (96) with benzylic and allylic halides
table 2.8

Products were isolated in moderate yields by displacement of the bromo group at the benzylic site of α -bromoethylbenzene to give (120), and at the allylic site of allyl bromide and 3-bromocyclohexene (104) giving (121) and (107) respectively.

However, the reaction of the organolithium reagent with 3-bromocyclopentene (103), did not yield the expected substituted cycloalkene (106) but bis(diethoxyphosphinyl)difluoromethane (122); a mechanism to rationalise this unexpected product is shown in scheme 2.8.

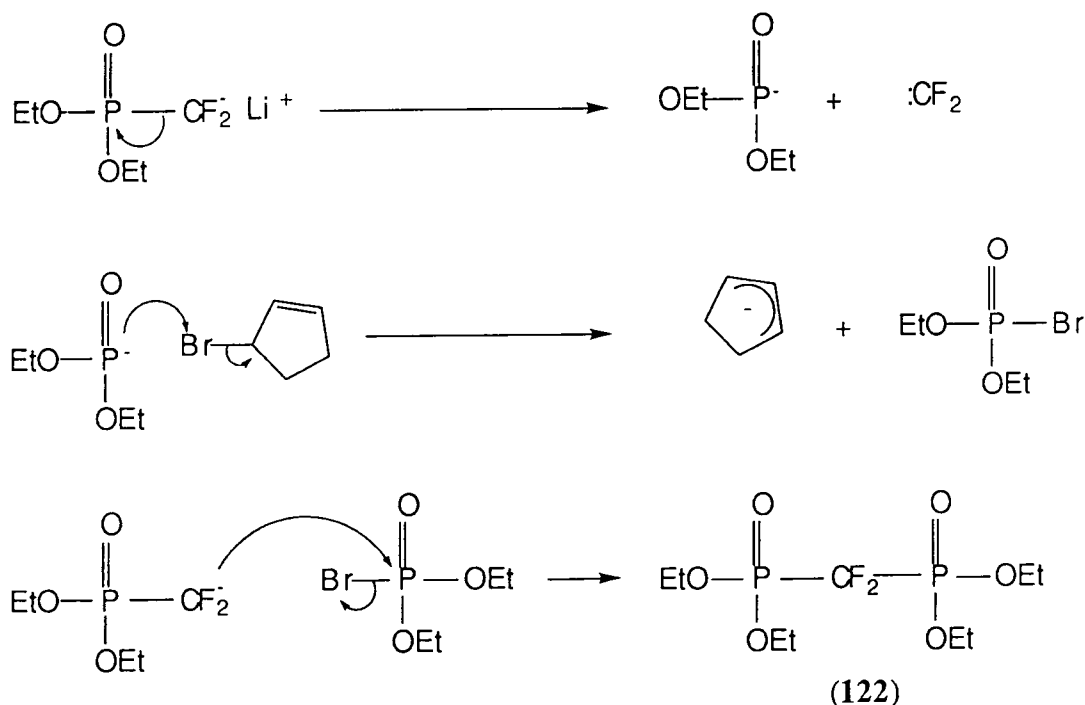

scheme 2.8

Evidence to support this mechanism comes from two sources:

- (i) quenching of the anion of (diethoxyphosphinyl)difluoromethane by bromine, which gave not only (diethoxyphosphinyl)bromodifluoromethane (**94**), but also bis(diethoxyphosphinyl)difluoromethane (**122**), the major product;
- (ii) Burton has shown that (diethoxyphosphinyl)bromodifluoromethane reacts with sodium di(*tert*-butyl)phosphite to give a mixture of symmetrical and unsymmetrical difluoromethylbisphosphonates,¹⁷³ a consequence of difluorocarbene scrambling *via* the unstable intermediate (diethoxyphosphinyl)difluoromethylene sodium.

Hence a bromophilic reaction must have occurred to give (**122**), it should be noted, however, our attempts to trap the carbene with cyclohexene proved unsuccessful.

II.C.3 Displacement of Other Leaving Groups by (96)

Diacetone-D-glucose (**123**) is an ideal model system for a sugar and allows some interesting chemistry to be done, in the form of the direct introduction of the (diethoxyphosphinyl)difluoromethylene unit.

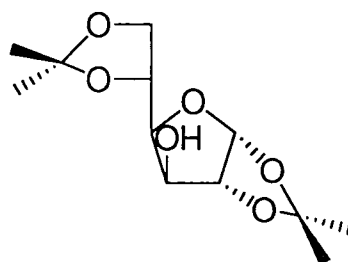

(**123**)

Initially the hydroxyl group was converted into the tosylate, or triflate, since the hydroxyl group is incompatible with the organolithium reagent (scheme 2.9).

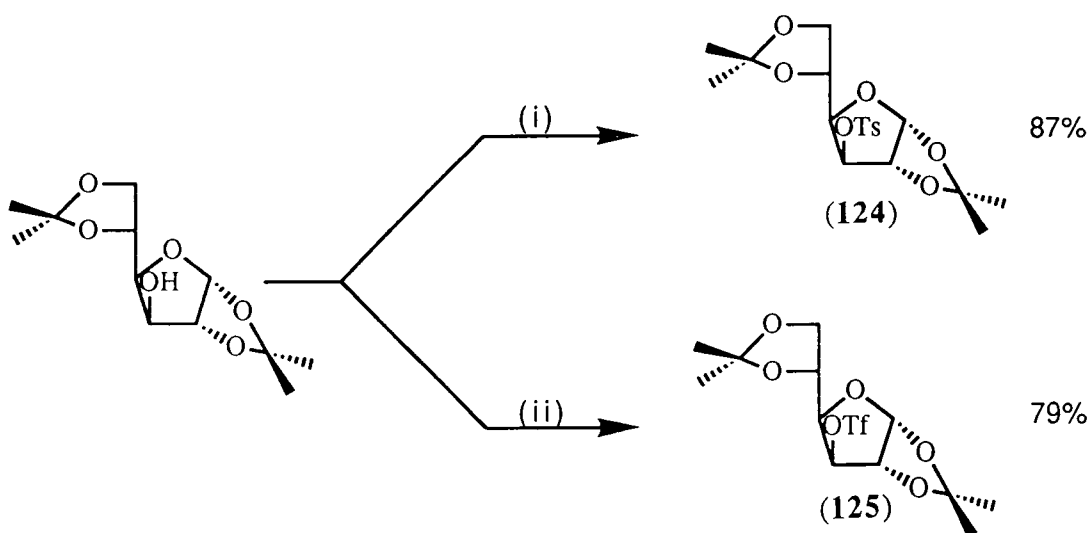

(i) pyridine, tosyl chloride TsCl, 0°C; (ii) pyridine, triflic anhydride (TfO)₂O, 0°C.
scheme 2.9

The tosylate (**124**)¹⁷⁴ and triflate (**125**)¹⁷⁵ of diacetone-D-glucose, obtained in high yield, were subsequently reacted under standard conditions with the lithium reagent (**96**). However, in both cases no reaction was apparent by ¹⁹F NMR.

Tosylate and triflate are often considered as very good leaving groups in organic chemistry, yet no reaction was observed. This must be due to steric crowding at the site for substitution, the (diethoxyphosphinyl)difluoromethylene anion being hindered by the steric bulk of the adjacent ketal group. The hard tosylate and triflate groups have been successfully displaced at primary carbon centres by Wolff-Kugel *et al.*¹⁴¹ in the synthesis of (**83**).

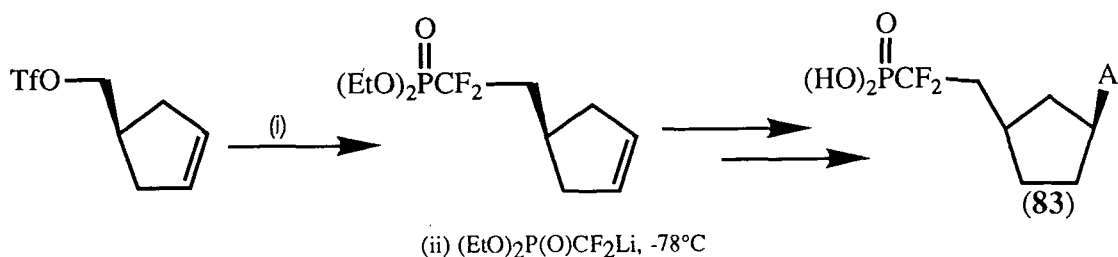

Thus it appears the lithium salt (**96**) is a poor nucleophile at secondary alkyl centres due most probably to steric hindrance.

II.C.4 Reaction of (**96**) with Oxirane

The reaction of organolithium reagents on epoxide rings has been well studied,¹⁷⁶ the reagents open an epoxide ring as shown in scheme 2.10.

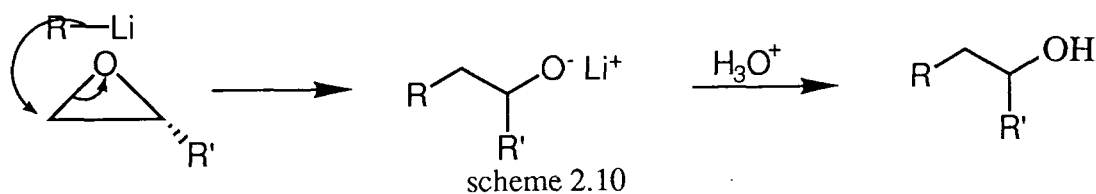

(Diethoxyphosphinyl)difluoromethylene lithium (**96**) was reacted with oxirane, the simplest of the epoxides, in an attempt to synthesise 1-(diethoxyphosphinyl)-1,1-difluoropropan-3-ol (**126**).

The ¹⁹F NMR spectrum showed that a new (diethoxyphosphinyl)difluoromethylene substituted product had been formed (figure 2.8), the product easily differentiated from (diethoxyphosphinyl)difluoromethane (**102**) by a change in the chemical shift of the two fluorine atoms down field; (diethoxyphosphinyl)difluoromethylene groups appendant on carbon chains occur in the region between -110 and -125ppm, differing greatly from (diethoxyphosphinyl)difluoromethane (**102**) in which the fluorine atoms resonate at -136ppm. Attempts to isolate the product by silica gel chromatography ended in failure with only starting material being recovered, however based on the NMR evidence this product is tentatively assigned as 1-(diethoxyphosphinyl)-1,1-difluoropropan-3-ol (**126**).

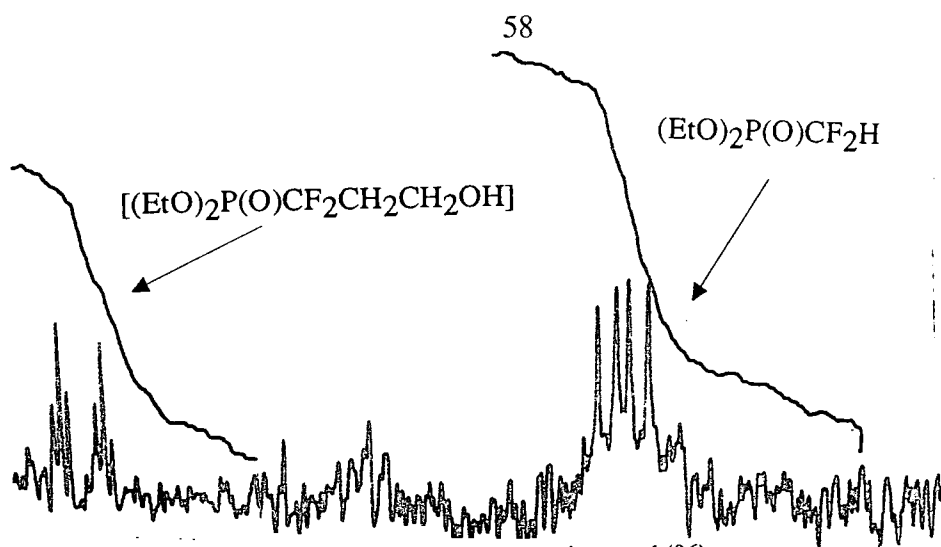

^{19}F NMR of the reaction between oxirane and (96)
figure 2.8

II.C.5 General Conclusion

The organolithium reagent is suitable for replacement at primary halide sites and for the ring opening of epoxides. However, the reagent does fall down at more crowded sites such as secondary halides and tosylates unless activation is present, *i.e.* substitution at benzylic or allylic carbon centres.

The effect of solvent on the generation of the anion has not yet been studied though Kim *et al.*³⁸ report the use of hexamethylphosphoramide increases the yield of a substitution reaction involving (diethoxyphosphinyl)difluoromethylene lithium from 0% to 23%.

II.D Reactions of 3-[(Diethoxyphosphinyl)difluoromethyl]cyclohexene (107)

The synthesis of nucleotide derivatives as potential antiviral agents is of obvious benefit. However, to accomplish this for carbocyclic systems based on the 3-[(diethoxyphosphinyl)difluoromethyl]cyclohexene skeleton it becomes necessary to functionalise the molecule by conversion of the double bond to such groups as the dihydroxy species, the epoxide, fluoride or even azide.

II.D.1 The Preparation of 1-[(Diethoxyphosphinyl)difluoromethyl]-2,3-epoxycyclohexene (127)

The simplest approach to epoxidise a double bond is *via* the action of a peracid,¹⁷⁷ however, initial studies carried out on (107) with magnesium monoperoxyphthalate in acetonitrile proved discouraging. Thus, an alternative procedure to epoxide (127) was affected *via* the chlorohydrin (scheme 2.11). The cycloalkene (107) was stirred for two days with an excess of calcium oxychloride in acetonitrile, producing the epoxide (127) in moderate yield, 52%.

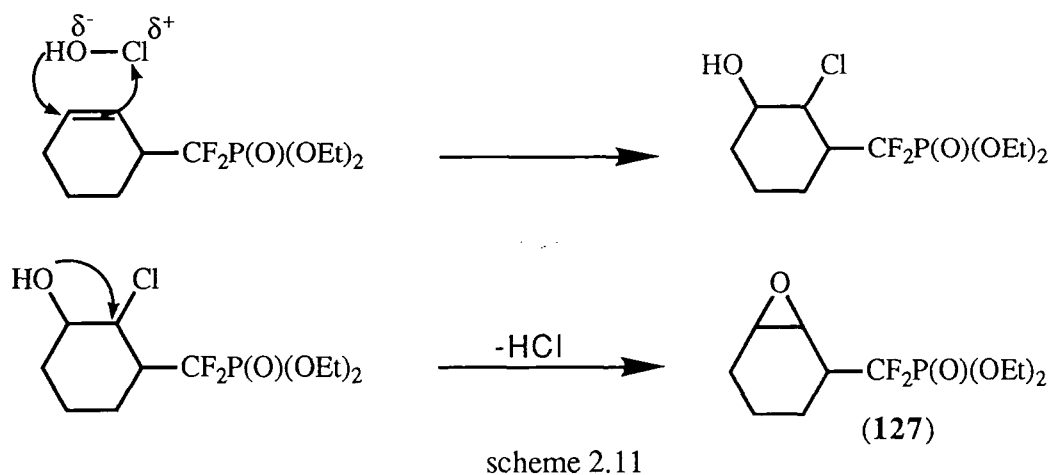

However, with the peracid 3-chloroperoxybenzoic acid the epoxide could be isolated in yields of upto 90%, after silica gel flash column chromatography.

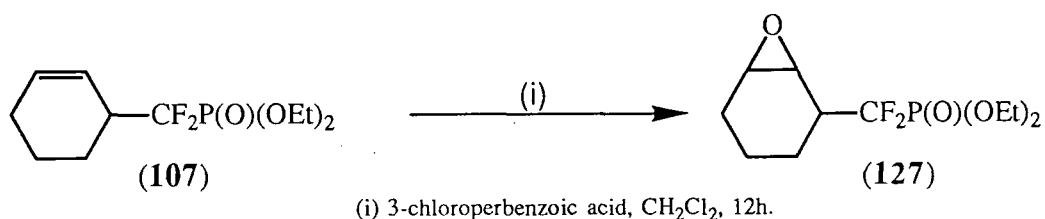

II.D.1.a The Stereochemistry of 1-[(Diethoxyphosphinyl)difluoromethyl]-2,3-epoxycyclohexene (127)

Epoxidation of a cyclohexenyl ring with an allylic substituent can give rise to two possible products (figure 2.9):

- (i) The *anti*-product (**127a**), which would be expected if the substituent is bulky, the peracid attacking from the least hindered face;
- (ii) The *syn*-product (**127b**), obtained where hydrogen bonding exists between the incoming peracid and the substituent, seen in allylic alcohols.¹⁷⁸

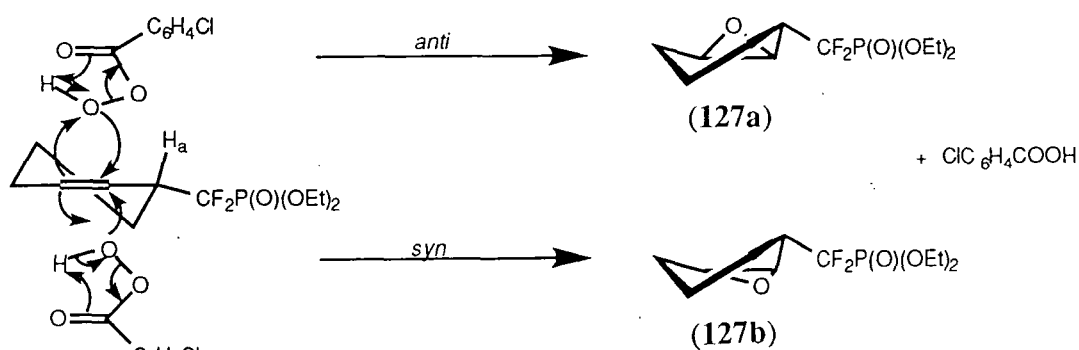
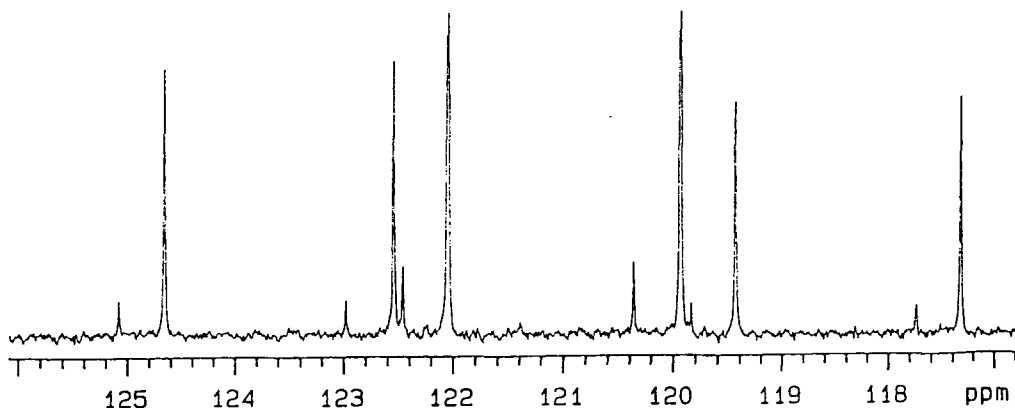

figure 2.9

The ^1H and ^{13}C NMR spectra for the epoxide (**127**) indicate predominately one product (figure 2.10) the ratio of the epoxides being 5:1. However, the structure could not be unequivocally assigned by elucidation of coupling constants, because, unlike

the cyclohexenyl systems assigned previously (section II.B.2.d) the energy barrier between the conformers of the epoxide is relatively low, molecular modelling (COSMIC) indicating at least three low energy conformations which could be adopted. Thus, the NMR is likely to be an equilibrium distribution of conformers.



a section of the ^{13}C NMR spectrum of (127) showing presence of the other isomer
figure 2.10

However, given the steric bulk of the (diethoxyphosphinyl)difluoromethylene group and the possibility of lone pair repulsion between the difluoromethylene group and the incoming peracid the stereochemistry of the groups can be tentatively assigned as the *anti*-product (127b).

II.D.1.b The Attempted Epoxide Cleavage of (127) with DAST

Diethylaminosulphur trifluoride (DAST) reacts with epoxides to form vicinal difluorides and bis(2-fluoroalkyl)ethers, the relative ratios of each being dependant upon the reaction temperature.¹⁷⁹ Since fluorine in the C2' and C3' position of nucleosides is advantageous for increased efficacy⁸² the epoxide (127) was reacted with DAST to isolate if possible 1-[(diethoxyphosphinyl)difluoromethyl]-2,3-*cis*-difluorocyclohexane (128)(scheme 2.12).

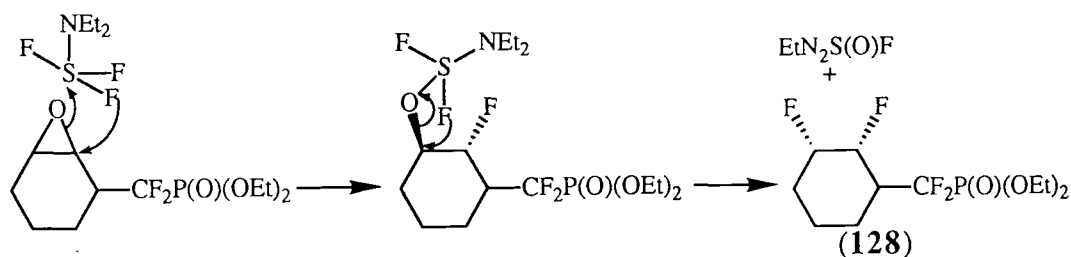

scheme 2.12

The epoxide (127) was added dropwise to neat DAST at 55°C, the reaction mixture rapidly darkened and was monitored by ^{19}F NMR. The broad DAST peak at -46.5ppm was seen to slowly disappear and a peak at -54.0ppm appear, due to the diethylaminosulphinyl fluoride. On quenching the reaction and extraction a ^{19}F NMR

spectrum indicated a large number of fluorine environments, none of which corresponded to the expected *cis*-difluoride. However, it was apparent that fluorination had occurred at the phosphorus centre, a doublet centred at -66.24ppm and a coupling of $\approx 950\text{Hz}$, characteristic of a $^1J_{\text{FP}}$ coupling,¹²¹ the materials were therefore destroyed in concentrated sodium hydroxide solution.

II.D.2 The Attempted Preparation of 1-[(Diethoxyphosphinyl)difluoromethyl]-2,3-Cis-dihydroxycyclohexane (128)

A number of routes exist to add two hydroxy groups to an alkene in a *syn* addition.¹⁷⁷ Potassium permanganate in alkaline solution has been used,¹⁸⁰ but rarely gives yields in excess of 50% due to the facile oxidation of the diols to diketones and then subsequent cleavage. Therefore, two alternative methods to *syn*-dihydroxylation were tried.

II.D.2.a Via a Catalytic Osmium Tetroxide/*N*-Methyl-Morpholine-*N*-Oxide System

Osmium tetroxide can be used to dihydroxylate alkenes both stoichiometrically¹⁸¹ and catalytically.^{182,183} However, due to the extreme toxicity of the reagent and high cost a catalytic method is preferred. O'Hagan¹⁸⁴ indicated that the allylic (diethoxyphosphinyl)difluoromethylene compound (**121**) could be hydroxylated with *N*-methyl-morpholine-*N*-oxide as the co-oxidant in a modest yield of 48% (scheme 2.13), thus similar conditions were tried for (**107**).

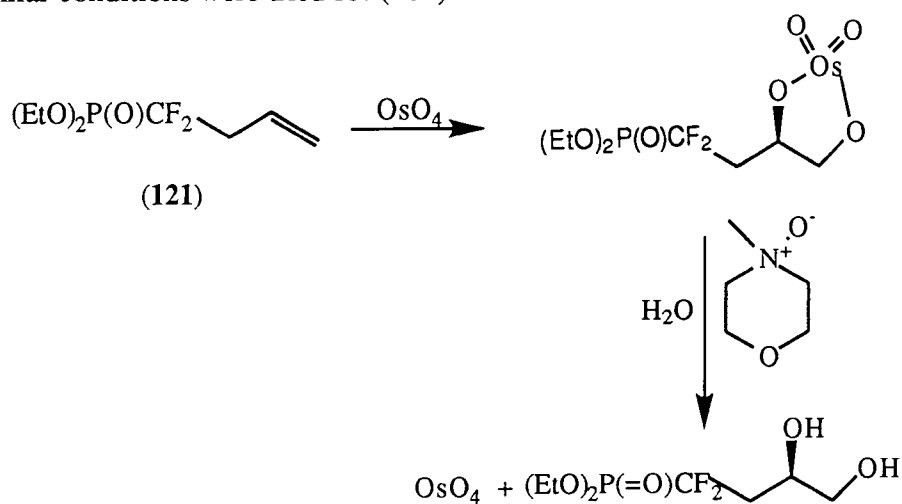

scheme 2.13

Unfortunately after 7 days no addition across the double bond could be observed by ^1H NMR. It can be surmised given the reactivity of (**121**) under these conditions that the difluorinated substituent is not responsible for the inactivity but rather the internal double bond of (**107**), literature reporting poor yields and sluggish reaction times for substituted alkenes.¹⁷⁷

II.D.2.b Via the Woodward Method

Woodward¹⁸⁵ found that when an alkene was treated with iodine and silver acetate in a 1:1 molar ratio in aqueous acetic acid that *syn*-hydroxylation results. Scheme 2.14 indicates possible intermediates, proceeding initially with the formation of the β -haloester; the addition is *anti* and a nucleophilic replacement of iodine occurs. The monoacetate is now *syn* and hydrolyses to give a diol with overall *syn* addition.

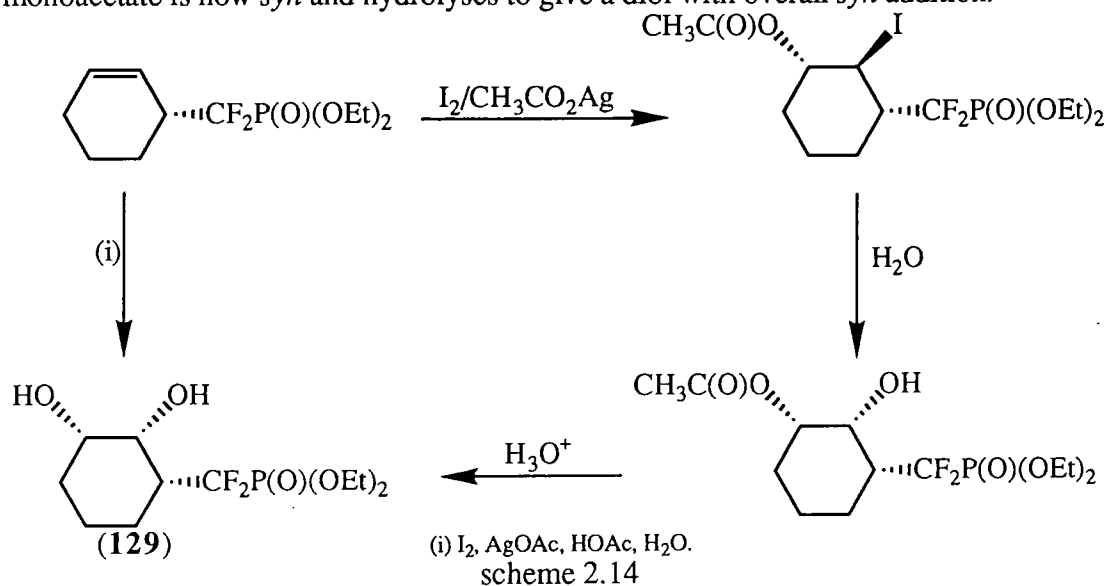

Again the *syn*-dihydroxy compound (**129**) could not be prepared, with the attempted reaction under Woodward's conditions resulted in only the starting material being isolated.

II.D.3 Conclusion

The alkenyl group in 3-[(diethoxyphosphinyl)difluoromethyl]cyclohexenyl systems is not easily converted to the highly desirable fluoro or hydroxy groups, probably due to three factors:

- (i) the (diethoxyphosphinyl)difluoromethylene group is an electron withdrawing group and thus disfavours the electrophilic substitution characteristic of alkenes;
- (ii) it contains a phosphorus centre which can be susceptible to nucleophilic attack;
- (iii) and the (diethoxyphosphinyl)difluoromethylene group is bulky hindering the attack of the double bond.

CHAPTER III

THE SYNTHESIS OF 3-(N⁹-ADENYL)-6-[(DIHYDROXYPHOSPHINYL)DIFLUOROMETHYL]CYCLOHEXENE (139) AND 3-(N⁹-GUANYL)-6-[(DIHYDROXYPHOSPHINYL)DIFLUOROMETHYL]CYCLOHEXENE (140)

III.A Introduction

Carbocyclic nucleoside derivatives have become increasingly important, with the discovery that the removal of oxygen from the sugar component of a nucleoside increases *in vivo* stability of the analogue to cleavage by phosphorylases.¹⁰¹ The routes employed to synthesise this class of compounds has recently been reviewed by Borthwick and Biggadike,¹⁰⁹ so only two features of the class will be discussed, the effect of ring size and introduction of unsaturation, on metabolic activity.

III.B Effect of Ring Size in Carbocycles

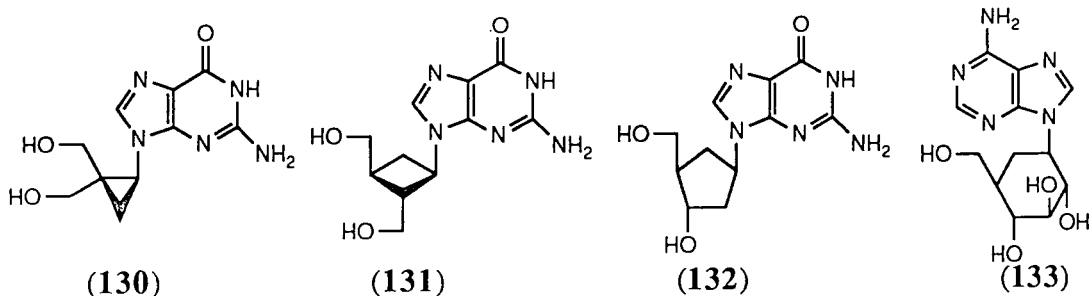

A number of carbocyclic nucleoside analogues have been synthesised with varying ring sizes, ranging from the three carbon cyclopropane ring to six carbon cyclohexane ring, *e.g.* (130),¹⁸⁶ (131),¹⁸⁷ (132)¹⁸⁸ and (133).¹⁸⁹ It should be noted, however, that not all showed antiviral properties,¹⁸⁶ the class showing the greatest potential, excluding the cyclopentane derivatives (section I.C.3.e), being those based on oxetanocin.

Japanese workers¹⁹⁰ in 1986 isolated a naturally occurring oxetane nucleoside, oxetanocin (134), from a strain of bacterium *Bacillus megeterium*. Oxetanocin is the only known example of a four membered ring nucleoside in nature, and showed not only antibiotic properties but activity against HIV.

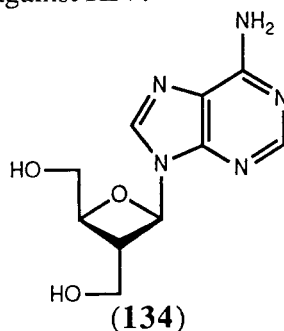

Further modification of (134) gave, in 1986, the carbocyclic analogue (131) utilising not adenine as the base but guanine. Indeed, compound (131) exhibits the greatest activity of all the oxetanocin analogues synthesised at present,¹⁹¹ and is extremely potent against HSV1 and HSV2 infections, *i.e.* one order of magnitude more effective than the current reference acyclovir (55).¹⁹⁰

III.C Effect of Unsaturation

Unsaturated nucleosides are of obvious benefit as intermediates and have been reviewed to this purpose by Zemlicka *et al.*¹⁹² However, much interest is now being expressed in the area, stemming from the isolation of the fermentation product neplanocin A (62),¹⁰⁴ a naturally occurring carbocyclic nucleoside, which possesses unsaturation between the C4' and C6' position, and exhibits a limited antitumour activity. Ohno¹⁰⁷ found the close analogue (63) was even more potent in its ability to selectively inhibit tumour cell growth and displayed antiviral properties,¹⁹³ thus giving rise to a range of nucleoside derivatives containing unsaturation.

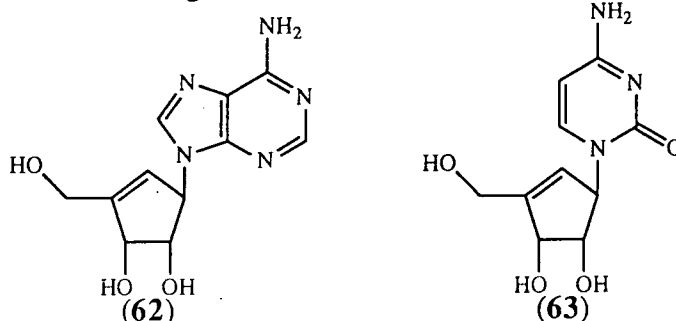

In 1990 Biggadike and Borthwick described a synthesis of the 4',6'-unsaturated derivative of 2'-*ara*-fluoro carbocyclic guanosine (32).⁹⁴ In order to increase antiviral activity of the unsaturated carbocyclic derivatives and simultaneously reduce the cytotoxicity, the new cyclopentenyl nucleoside (135) included the important 2'-*ara*-fluoro substituent, known to confer antiviral activity (section I.C.3.a). The nucleoside analogue (135) was found to be equipotent to acyclovir *in vitro*.

Unsaturations are not only confined to the C4'/C6' position, with the synthesis of the non-carbocyclic 2',3'-dehydro analogues (136) and (137),¹⁹⁴ both of which exhibited potent activity in the inhibition of RT,¹⁹⁵ necessary for the integration of the HIV virus' genetic information into the host cell genome in the form of DNA, comparable to that of AZT (37) and have been used in the clinic.

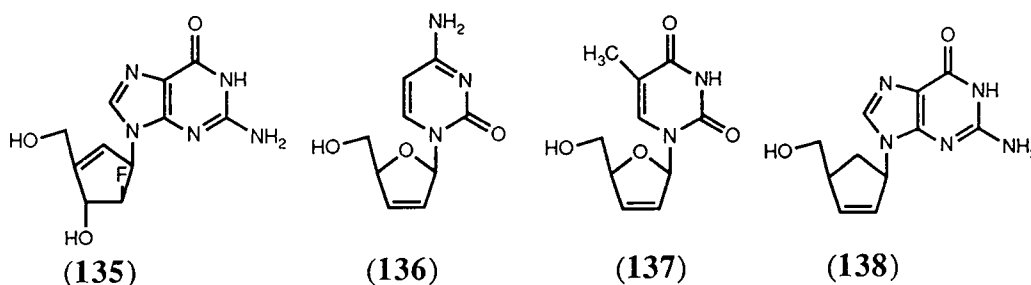

Carbocyclic 2',3'-unsaturated variants have also been prepared, however, the most hopeful 2',3'-dideoxy-2',3'-didehydroguanosine (**138**) is only as effective an inhibitor of HIV RT as AZT (**37**), though of reduced toxicity.¹⁹⁶

The mode of action of the unsaturated congeners is not fully understood, but in the case of the 2',3'-unsaturated nucleosides the absence of the C2' and C3' hydroxy functionality does, as previously discussed (section I.C.3.a), chain terminate DNA or RNA synthesis by negating the possibility of 3' to 5' phosphate linkages. However, it is necessary to invoke further explanation for 4',6'-unsaturated nucleosides because although the saturated analogue of (**62**)¹⁹⁷ expresses antitumour activity *in vivo* via the same pathway as the unsaturated analogue, it is two orders of magnitude less potent, indicating (**62**) is a more effective substrate for cytidine triphosphate synthetase; the enzyme responsible for *de novo* pyrimidine biosynthesis, catalysing the synthesis of cytidine triphosphate from uridine triphosphate.¹⁹³

III.D Synthesis of 3-(N9-Adenyl)-6-[(dihydroxyphosphinyl)difluoromethyl]cyclohexene (139) and 3-(N9-Guanyl)-6-[(dihydroxyphosphinyl)-difluoromethyl]cyclohexene (140)

Given the interest in carbocyclic nucleosides, we therefore embarked upon the synthesis of the unsaturated cyclohexenyl derivatives (**139**) and (**140**). The methodologies for coupling nucleoside bases to sugar analogues are well defined, three basic strategies commonly being deployed; the Mitsunobu reaction,¹⁹⁸ ring opening of an epoxide¹⁹⁹ and halogen displacement.²⁰⁰ In devising a synthetic route to the carbocyclic nucleotides 3-(N9-adenyl)-6-[(dihydroxyphosphinyl)difluoromethyl]cyclohexene (**139**) and 3-(N9-guanyl)-6-[(dihydroxyphosphinyl)difluoromethyl]cyclohexene (**140**) two of these approaches were attempted (scheme 3.1); method A proceeding *via* a Mitsunobu reaction with the allylic alcohol (**141**),²⁰¹ while method B proceeds *via* halogen displacement at the activated allylic position.²⁰²

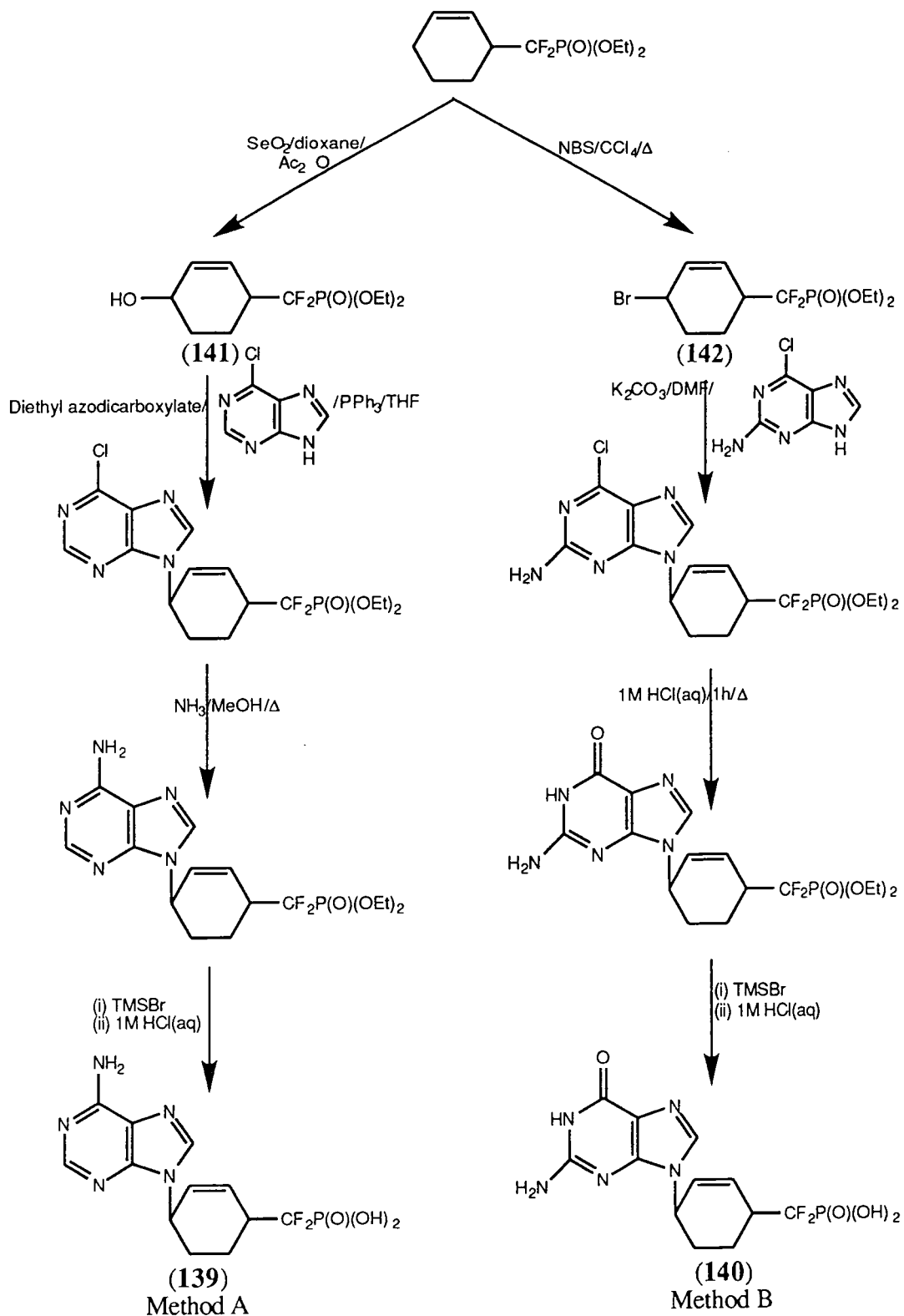

scheme 3.1

III.D.1 Method A: Via Allylic Oxidation of 3-[(Diethoxyphosphinyl)-difluoromethyl]cyclohexene (107)

Treatment of double bond compounds with selenium dioxide introduces a hydroxy functionality into the allylic position.²⁰³ The mechanism for this reaction is not radical but involves two pericyclic steps, an ene-type reaction and a [2,3] sigmatropic shift (scheme 3.2).²⁰⁴

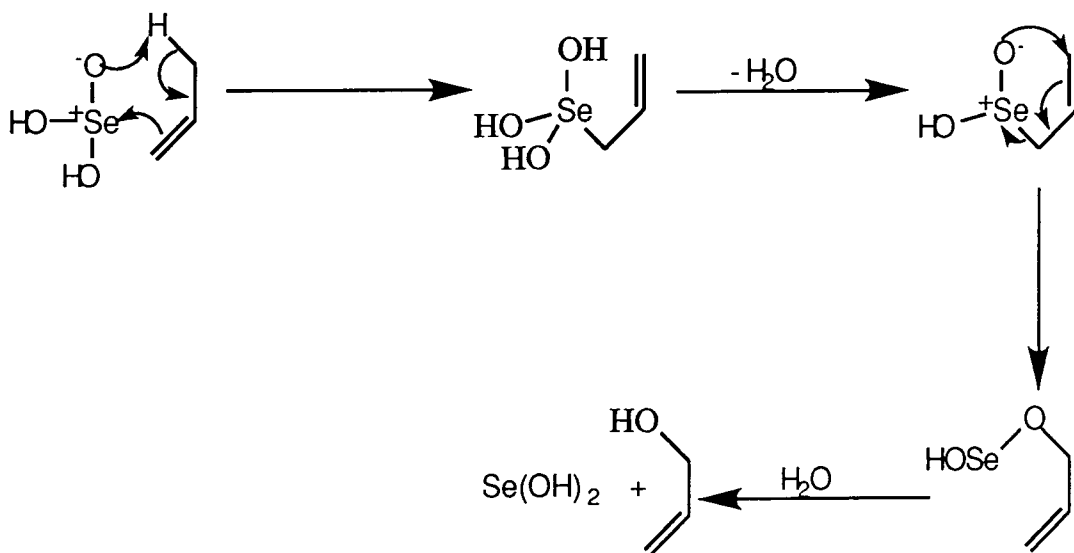

scheme 3.2

It was found that the literature method for allylic oxidation, by use of selenium dioxide in dioxane-acetic acid, yielded only a small quantity, 16%, of the desired alcohol (**141**), after hydrolysis, even after prolonged heating. Indeed, the yields of alcohols from sterically hindered or highly substituted alkenes are generally low, and in a sterically analogous substituted cyclohexenyl system 3-methylcyclohexene Trachtenberg and Carver²⁰⁵ cited a yield of less than 15% for the isomeric mixture of (*Z*)- and (*E*)-6-methylcyclohexen-3-ol. It can be postulated that the yield is further reduced by virtue of the fact that the initial step of the reaction involves nucleophilic attack by the double bond, *via* an 'ene'-type step, thus the decreased electron density due to the presence of the electron withdrawing (diethoxyphosphinyl)difluoromethylene moiety would be expected to retard attack of the hydrated selenium dioxide reducing the rate and correspondingly the yield of the allylic alcohol.

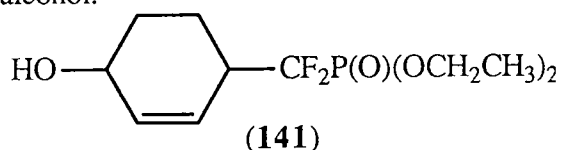

NMR studies clearly showed that no 3,3-disubstituted cyclohexenyl product was produced in the reaction, the remainder of the material recovered being starting material. Given the poor yield of effectively the first step of the reaction it was decided to follow method B.

III.D.2 Method B: Via Allylic Bromination of 3-[(Diethoxyphosphinyl)-difluoromethyl]cyclohexene (107)

The halogenation of alkenes in the allylic position by *N*-halosuccinimides is well documented,²⁰⁶ first being reported by Wohl in 1919.²⁰⁷ The reaction is a special case of alkyl halogenation proceeding *via* a free radical process to give excellent yields of the allylic substituted haloalkene (scheme 3.3).²⁰⁸

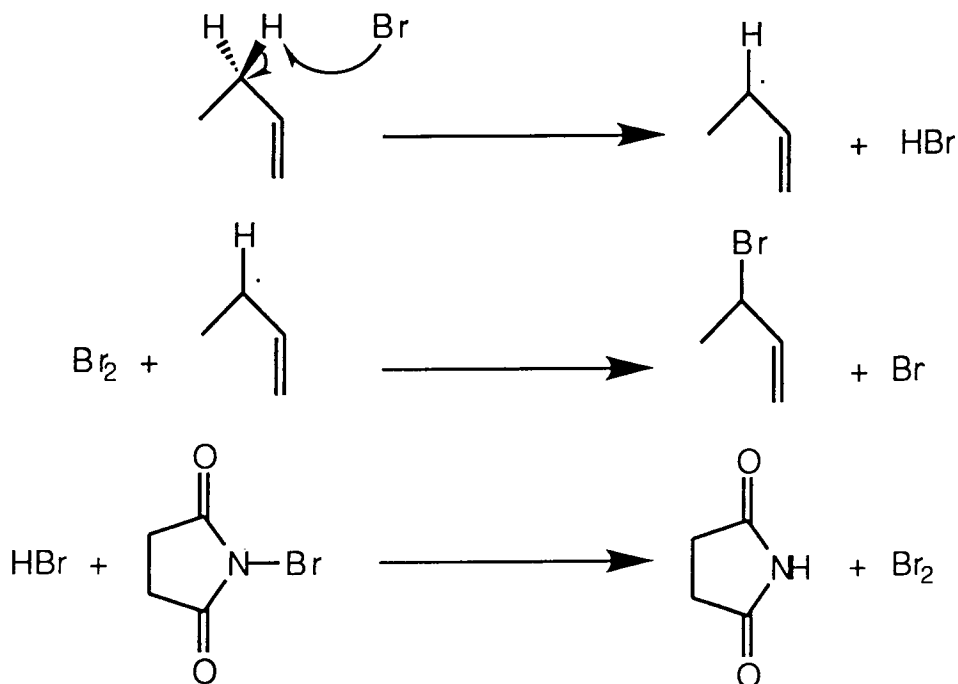

As can be seen from the scheme 3.3, bromine in low concentration is the actual halogenating agent. The double bond is not halogenated by bromine, either radically or ionically (figure 3.2) because, after initial bromination, only one atom of an attacking bromine moiety becomes attached to the substrate, to give an unstable intermediate.

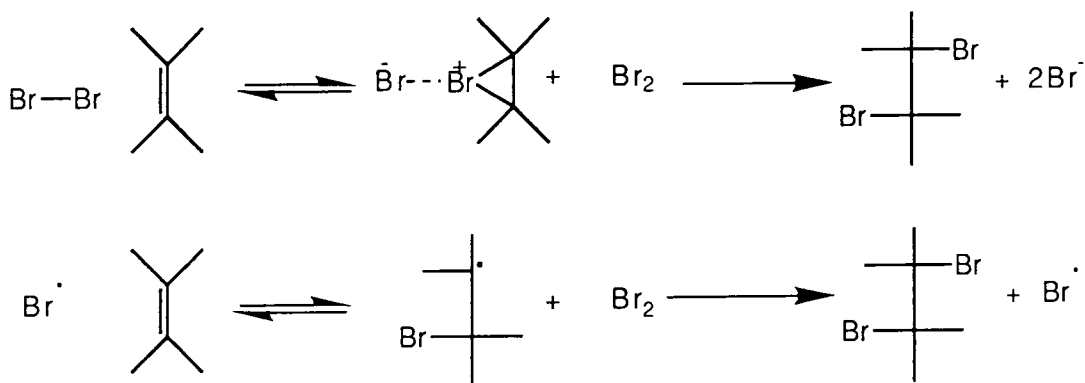
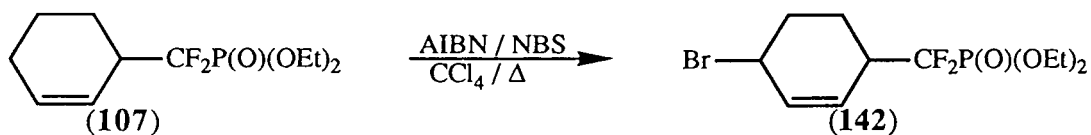

figure 3.2

This must subsequently react with a second bromine containing molecule, however, there is a low probability that the desired species will be in the vicinity, thus the intermediate disproportionates back to starting materials. This hypothesis was verified by M^cGarth and Tedder,²⁰⁹ whom carried allylic bromination using bromine in very low concentration, removing any hydrogen bromide generated.



scheme 3.4

The reaction of the substituted alkene (**107**) with *N*-bromosuccinimide was therefore undertaken utilising the standard conditions of α -azo-*isobutyronitrile*, initiator, in carbon tetrachloride (scheme 3.4). The crude product so obtained was purified by flash column chromatography (eluent hexane-acetone; 3:2) to give in 78% yield (**142**) as a clear colourless oil. The stereochemical outcome of the reaction was determined by NMR experiments. It has been shown previously that the (diethoxyphosphinyl)difluoromethylene group adopted a pseudoequatorial conformation (section II.B.2.d), thus, since the allylic bromination reaction occurs at a remote centre *via* a free radical addition process, no alteration of the stereochemical assignment of the (diethoxyphosphinyl)difluoromethylene group would be expected. Indeed, the indication in the ^1H NMR that (**142**) was a mixture of two isomers must be due to bromine disposed in a pseudoequatorial conformation (**142a**) and in (**142b**) in a pseudoaxial conformation. This was not unexpected given the limited stereochemical control in free radical reactions, *i.e.* allylic bromination, the ratio of the two isomers being approximately 1:1.

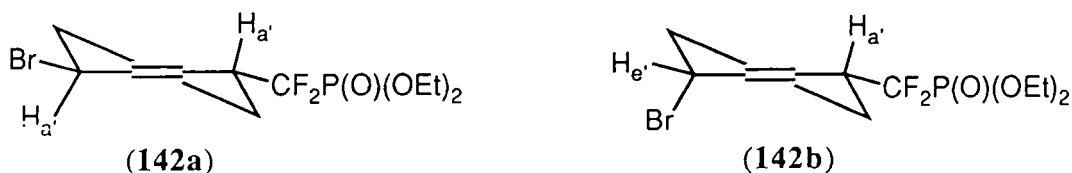

No attempt was made to separate the isomers, at this stage, due to the relative instability of cyclic 3-bromoalkenes previously synthesised, *i.e.* (**103**), (**104**) and (**105**). NMR also demonstrated that no 3,3- or 3,4-disubstituted derivatives were present.

The absence of the 3,3-disubstituted product can be rationalised by two factors: steric, the bulky (diethoxyphosphinyl)difluoromethylene group hinders attack of bromine; and electronic, Pearson and Martin²¹⁰ showed the effect of electron donating and withdrawing substituents on hydrogen abstraction by bromine radicals on *para*-substituted toluenes. The overriding factor dictating rates was the polar transition state in the generation of the radical centre (figure 3.3).

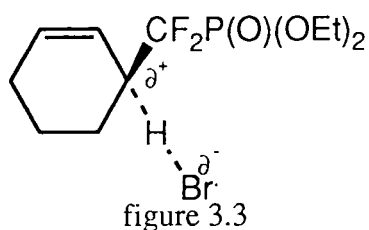

Thus the developing positive charge on the site adjacent the electron withdrawing group is destabilized, raising the energy of the system, *i.e.* the electrophilic bromine radical shuns the site due to its low electron density.

A 3,4-disubstituted product could arise due the possibility of an allylic shift in the intermediate unsymmetrical allylic radical generated (figure 3.4).²¹¹ However, a COSY spectrum of (142) indicated no coupling between the CHBr proton and the CHCF₂ proton (figure 3.5).

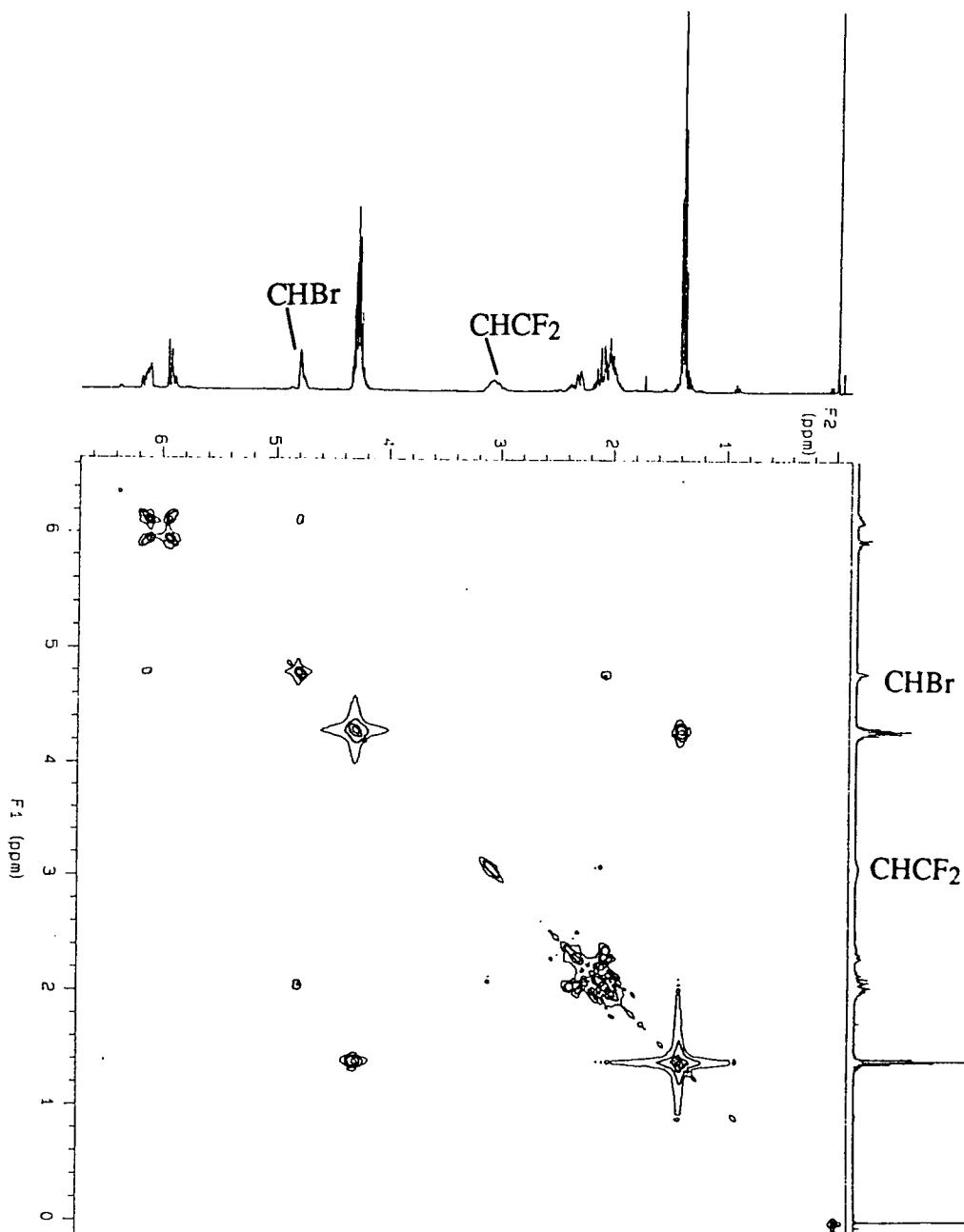
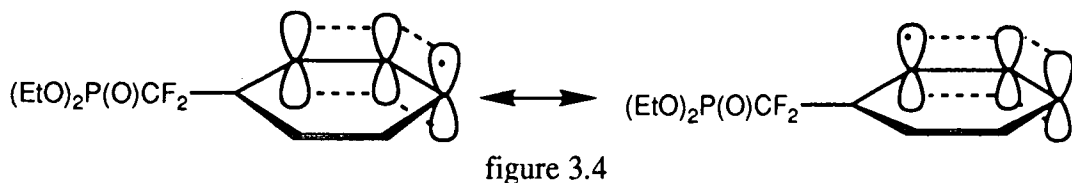

III.D.2.a Reaction of 3-Bromo-6-[(diethoxyphosphinyl)difluoromethyl]cyclohexene (142) with 6-Chloropurine (144)

It was determined at an early stage that the easiest method to couple the nucleoside base would be under the conditions developed by Schaeffer and co-workers for 2-bromocyclohexene.²¹² *N,N*-Dimethylformamide, a strongly polar aprotic solvent, was used to facilitate the S_N2 displacement reaction, effectively lowering ΔG^\ddagger by destabilising (raising) the ground-state energy level of the nucleophile, *i.e.* the nucleoside base. Potassium carbonate was present to act as a base, scavenging hydrogen bromide liberated during the reaction, which could attack the double bond to give the undesired bromide (**143**) (*N.B.* the competing electrophilic addition process would also be promoted by the polar solvent).

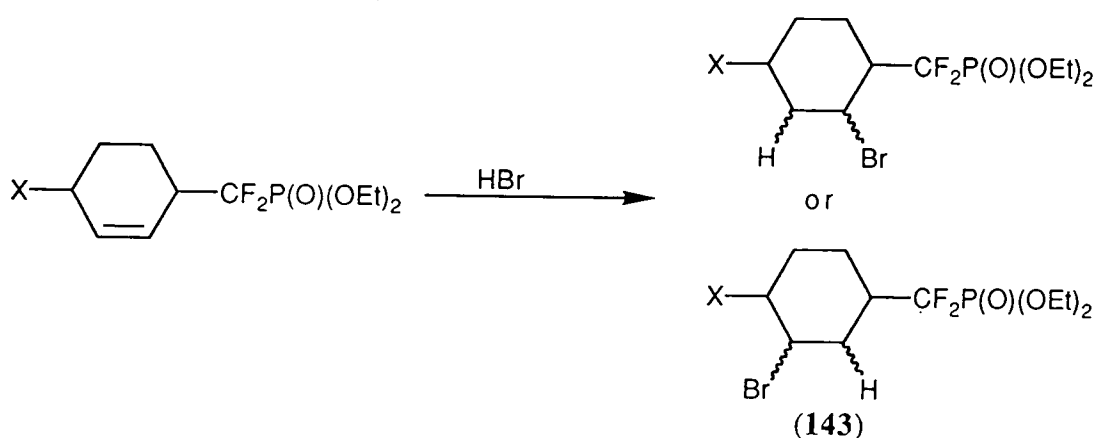

On completion of the reaction of the allylic bromide (**142**) with the 6-chloropurine (**144**) the desired coupled product 3-[*N*9-(6-chloropuriny)]-6-[(diethoxyphosphinyl)difluoromethyl]cyclohexene (**145**) was isolated in 46% yield (based on recovered starting material), after flash chromatography (eluent ethyl acetate). Two isomers were then separated by further chromatography (eluent ethyl acetate-hexane; 3:2). The stereochemical course of the reaction was deduced as illustrated below.

III.D.2.b Geometry of the Isomers of 3-[*N*9-(6-Chloropuriny)]-6-[(diethoxyphosphinyl)difluoromethyl]cyclohexene (145)

The course of substitution to give (**145**) is not as simple as first envisaged (scheme 3.5).

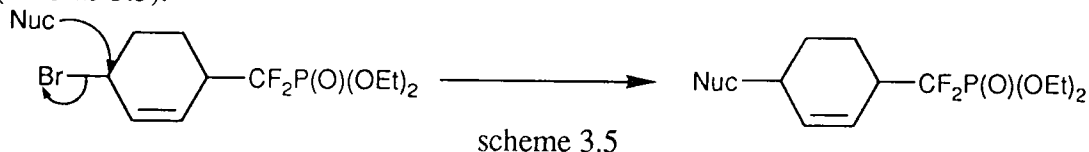

The variables in the reaction which need to be considered are:

- (i) the substitution mechanism S_N1 or S_N2/S_N2' ;
- (ii) the possibility of allylic shifts;

(iii) the purine (**144**) can react as a nucleophile at two sites, N7 or N9.

all these factors can be addressed by interpretation of spectral data.

It follows from the π -electron excessive character of the imidazole ring²¹³ that either of the nitrogen atoms is potentially available for electrophilic substitution. The electron density map of (**144**) (COSMIC, Liverpool charge method) indicates that N9 is the most nucleophilic centre (figure 3.5), and these results are borne out experimentally.²⁰⁰

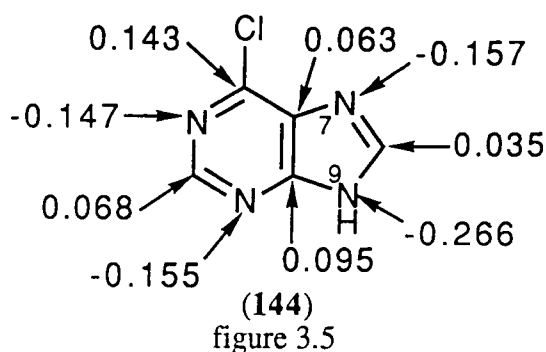

Thus, the reaction should proceed to give predominantly the desired N9 substituted product. The N7 product can be easily differentiated from the desired N9 substituted compound by observing the ultraviolet absorption spectra, N9 substituted products show characteristic absorption at 266nm while N7 substituted analogues absorb at 270nm,²⁰⁰ the ultraviolet absorption at 265nm confirming N9 substitution in compound (**145**).

Nucleophilic attack at an allylic site can proceed either *via* a S_N1 or as previously discussed an S_N2/S_N2' process. The NMR spectrum of (**145**) was indicative of a 3,6-disubstitution pattern, rather than the possible 3,4-disubstitution pattern in the ring of (**146**), a product which would be common for both a S_N1 or S_N2' process. In a S_N1 process allylic shifts are extremely facile,²¹⁴ because of the subsequent generation of a delocalised allylic cation, hence, a mixture of 3,6- and 3,4- disubstituted products would be expected, the 3,4-product is not observed. The S_N2' mechanism will be slightly disfavoured by the steric inhibition of the (diethoxyphosphinyl)difluoromethylene group to the approach of the bulky nucleophile (**144**) (scheme 3.6). Thus it can be concluded that an S_N2 process is the most likely mechanism in operation.

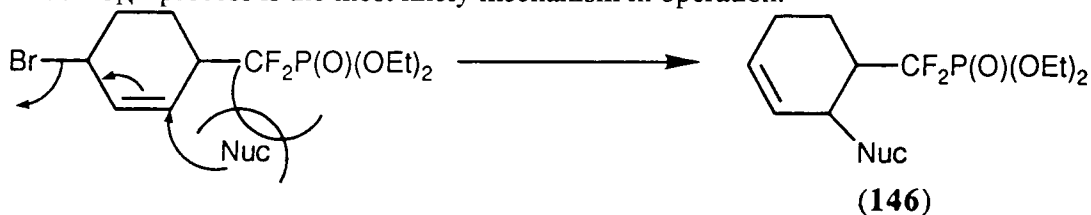

scheme 3.6

Two distinct sets of ^1H , ^{13}C and ^{19}F NMR resonances were observed for the allylic bromide (**142**), this can be reconciled by considering that with two chiral centres, four stereoisomeric compounds would be formed, of these two are merely enantiomers of the others *i.e.* RR/SS (**142a**) and SR/RS (**142b**), thus only two possible diastereoisomers can be distinguished by NMR. Therefore, we would expect the attack of the base (**144**) to give the corresponding isomers RS/SR (**145a**) and SS/RR (**145b**) respectively under a $\text{S}_{\text{N}}2$ mechanism (scheme 3.7).

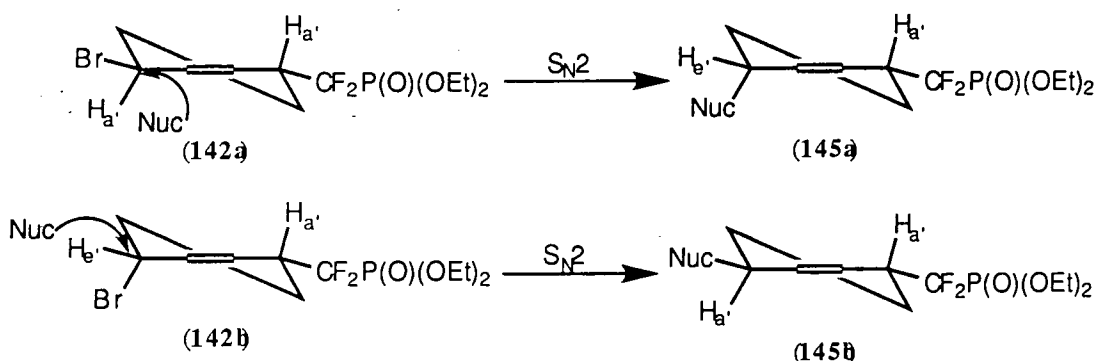

scheme 3.7

Indeed this was the case for compound (**145**); two isomers were observed in the relative ratios 1:1, determined by comparison of the integration heights of the ^1H NMR resonances in the alkenyl region, representing the two sets of diastereoisomers.

The preferred conformation of the cyclohexene ring is a twist chair,¹⁶¹ verified by modelling of the 6-chloropurine derivative (**145**) on the Sybyl package (version 5.4). Therefore, it was thought the absolute configuration of each diastereoisomeric pair could be elucidated *i.e.* which of the isolated isomers of (**145**) was the RR/SS diastereomeric pair and which was RS/SR diastereomeric pair.

Two dimensional NMR studies were used, therefore, to assign unambiguously the structure of the two isolated isomers of (**145**), notably heteronuclear correlation (HETCOR). The HETCOR technique is a plot of coupling between ^{13}C and ^1H nuclei, in the case shown in figure 3.5 the coupling was optimised over three bonds. The Karplus equation states that if a 0° or 180° relationship (or close to these ideal maxima) exists for the dihedral angle between a proton and a carbon atom three bonds removed, then a large coupling between the atoms will be observed. However, if the relationship between them tends to 90° then little or no coupling will be observed.²¹⁵

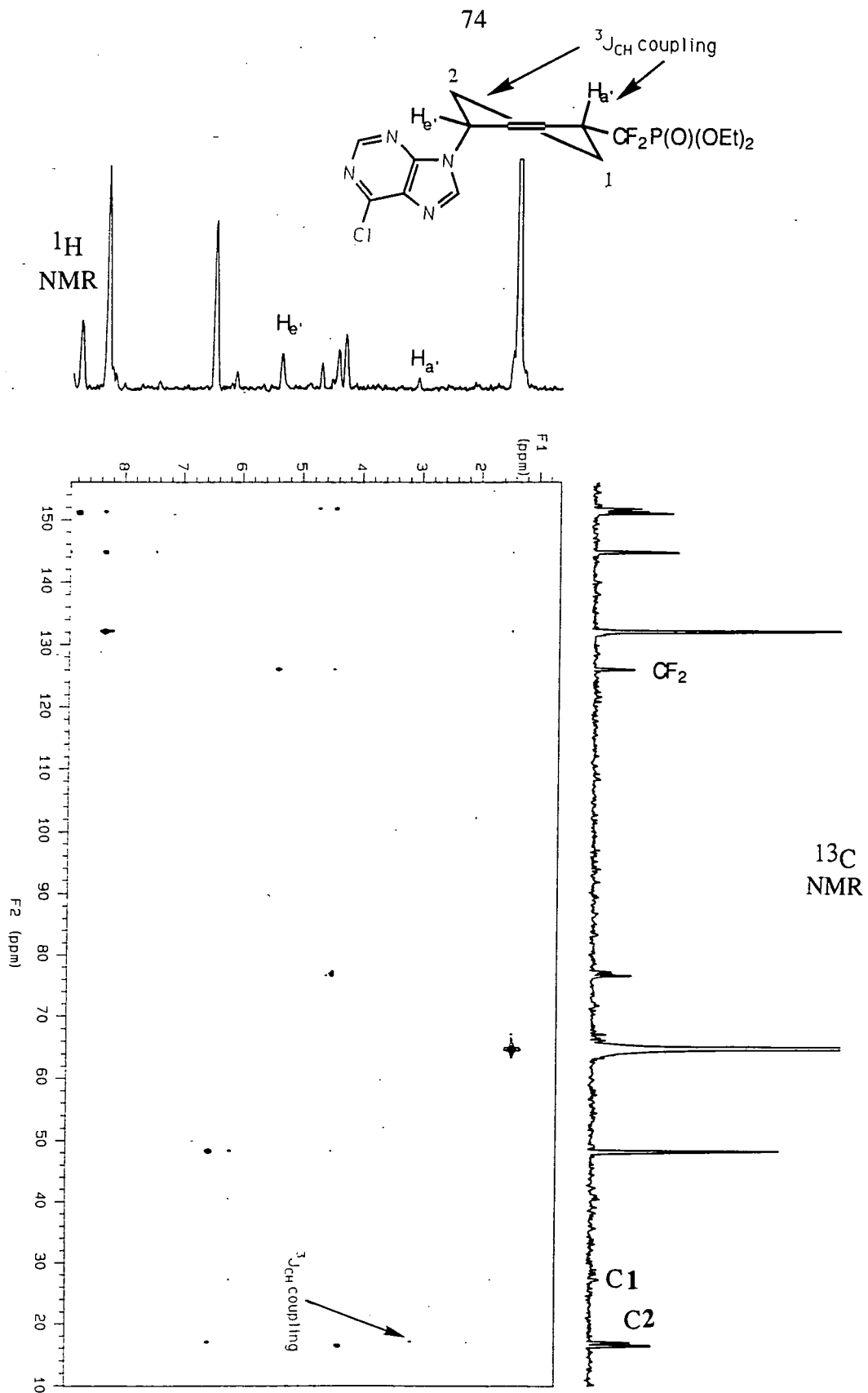
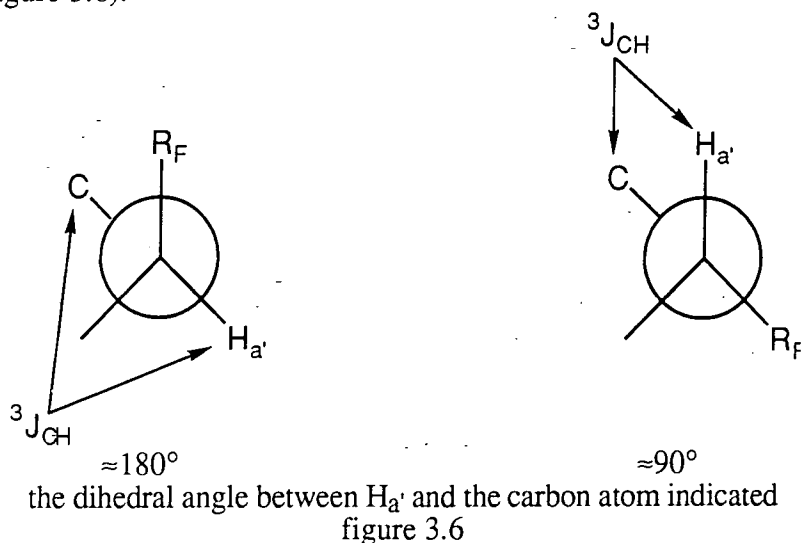

figure 3.5

For the system under study the key feature is the coupling between the isolated proton geminal to the (diethoxyphosphinyl)difluoromethylene moiety in the cyclohexene ring ($H_{a'}$) and the carbon atom marked. If the proton $H_{a'}$ is pseudoaxial then no coupling will be observed *i.e.* the dihedral angle between $H_{a'}$ and the carbon marked tends to 90° , while if the proton is predisposed in a pseudoequatorial position coupling will be observed (figure 3.6).



As can be seen from figure 3.5 coupling is evident between $H_{a'}$ (seen at 3.04ppm) and the vicinal carbon (seen at 17.1ppm), hence the proton geminal to the (diethoxyphosphinyl)difluoromethylene moiety in isomer A is equatorial. The HETCOR spectrum for isomer B showed no coupling so it can be assumed that the geminal proton in isomer B is pseudoaxial.

The position of the purine functionality can be assigned from the one dimensional 1H NMR (figure 3.7); the alkenyl protons in isomer A show one half of the AB splitting pattern to be heavily coupled. This will be due to $^3J_{HH}$ coupling between the pseudoequatorial proton $H_{a'}$ and the vicinal alkenyl proton. If the proton geminal to the purinyl functionality is also equatorial then it would follow that a similar $^3J_{HH}$ coupling would be seen on the other half of the AB splitting pattern. This is clearly not observed; thus, in isomer A since the (diethoxyphosphinyl)difluoromethylene group is pseudoaxial then the purinyl base must be pseudoequatorial, *i.e.* a *cis*-structure (**145a**)(*SR/RS*). For isomer B only structure (**145b**) is feasible, with no fine coupling on either half of the AB splitting pattern, indicative of two pseudoequatorial groups (*SS/RR*).

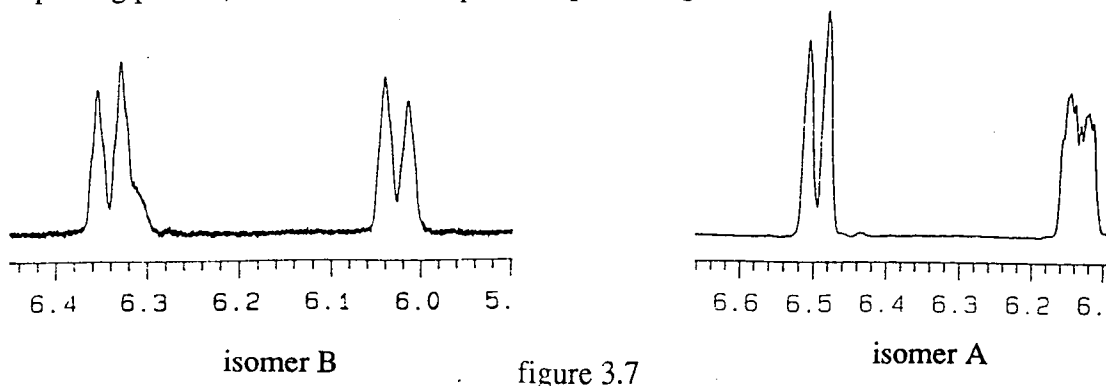

The 2D NMR spectrum also indicates that the 6-chloropurinyl group is energetically favoured in a pseudoequatorial position, *cf. tert*-butyl, thus to maintain a *cis*-configuration flipping of the cyclohexenyl ring in the case of (**145a**) must have occurred *i.e.* going from the a'e' to an e'a' conformation.

III.D.2.c Synthesis of (\pm)-3-(N9-Adenyl)-6-[(diethoxyphosphinyl)-difluoromethyl]cyclohexene (**147**)

In the synthesis of compound (**147**) problems were encountered in the conversion of the 6-chloropurine derivative (**145**) into compound (**147**), various methodologies proving unsatisfactory.

Literature methods for the nucleophilic aromatic substitution of the 6-chloro group in purine derivatives are numerous. The most common procedure, amination using saturated methanolic ammonia at high temperature,^{141,216} did not yield in sufficient quantity the desired product. TLC indicated total consumption of the starting material, confirmed by the appearance of two new spots of greater polarity than the starting material (**145**). However, attempts to then isolate these two products by flash chromatography yielded only the faster moving component, confirmed as the desired product (**147**), in only 1.1% yield (eluent chloroform-methanol; 9:1), while the slower moving, major, component remained on the column even after ramping of solvent mixture to 100% methanol.

To obviate the poor yield of compound (**147**) a variety of means were tried (table 3.1), including the effect of temperature to increase the ratio of the desired faster moving component (**147**) over that of the baseline material, this method proved unsatisfactory due to, in some instances, incomplete consumption of the starting material. French workers²¹⁷ described a high yielding route to amines *via* azide reduction, again the method failed to give any of the adenine derivative (**147**). Given the increased proclivity of fluorine to undergo nucleophilic aromatic substitution²¹⁸ the conversion of the 6-chloro group to the 6-fluoro moiety was attempted, to obviate the sluggish substitution of the chloro group, using both silver (I) fluoride⁶¹ and silver (II) fluoride.²¹⁹ Silver (I) fluoride had no effect on compound (**145**), only starting material being isolated, while the use of silver (II) fluoride resulted in fragmentation and decomposition of (**145**).

† The stereochemical assignment of the (diethoxyphosphinyl)difluoromethyl group is stated last in all cases.

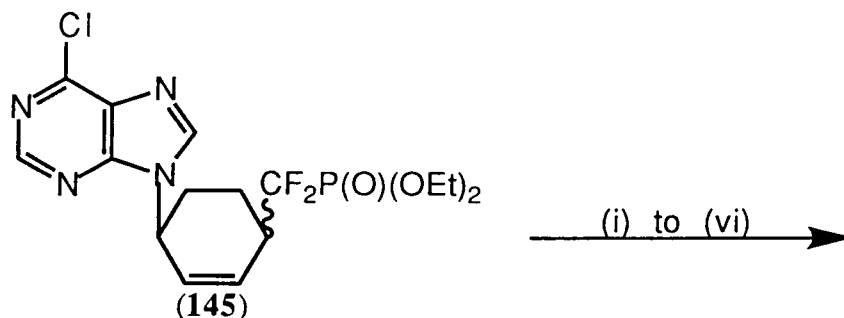

Number	Conditions	Results
(i) ²¹⁷	(a) NaN ₃ /DMF (b) PPh ₃ /THF (c) H ₃ O ⁺	Decomposition of (145)
(ii) ²²⁰	NaNH ₂ /DMF	No reaction
(iii) ²²¹	NH ₃ (l)/2h	No reaction
(iv) ¹⁴¹	NH ₃ /MeOH/100°C	1% of (147) and decomposition of (145)
(v) ⁶¹	AgF/PhCH ₃ /Δ	No reaction
(vi) ²¹⁹	AgF ₂ /CHCl ₃	decomposition of (145)

Attempted nucleophilic displacement reactions at the 6-position of 6-chloropurine
table 3.1

The product was finally isolated in good yield by the use of aqueous dioxane-ammonia solution giving (147) in 66% yield, after purification by flash silica gel chromatography (eluent 5:1 chloroform-methanol). The choice of solvent system was based on earlier work carried out in our laboratory in relation to nucleophilic substitution, where dioxane was found to be an excellent solvent.

III.D.2.d Deprotection of (±)-3-(N9-Adenyl)-6-[(diethoxyphosphinyl)-difluoromethyl]cyclohexene (145)

The final deprotection of the diethoxyphosphinyl residue to yield the free acid was accomplished by the standard literature method,²²² *via* hydrolysis of the trimethylsilyl ester. The ester was synthesised by stirring compound (147) in twenty equivalents of trimethylsilyl bromide (no solvent is necessary), failure to use a vast excess of the silyl reagent resulted in a mixture of mono- and di-silyl esters, easily seen by TLC on cellulose plates (eluent methanol). The reaction was followed by the consumption of the starting material, which upon silylation became soluble in the reaction mixture. The solution was then hydrolysed by dilute mineral acid, the intermediate silyl ester never being isolated.

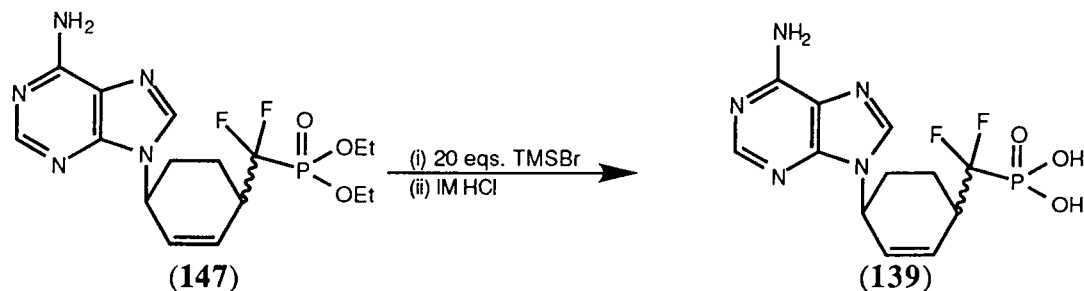

Purification of the crude nucleotide was then accomplished by evaporation to dryness of the reaction mixture, thus removing any volatile silyl components, and repeated washing with methanol, to remove traces of water and hydrogen bromide. The nucleotide (139) was then purified by reverse phase chromatography (eluent water) to yield (139) in 73%, a total overall yield of 17% from 3-[(diethoxyphosphinyldifluoromethyl)cyclohexene (107).

III.D.2.e Reaction of 3-Bromo-6-[(diethoxyphosphinyldifluoromethyl)cyclohexene (142) with 2-Amino-6-chloropurine (148)

The coupling of 2-amino-6-chloropurine (148) to the allylic bromide (142) was performed under the same conditions as those outlined for the 6-chloropurine derivative (144)(scheme 3.8).

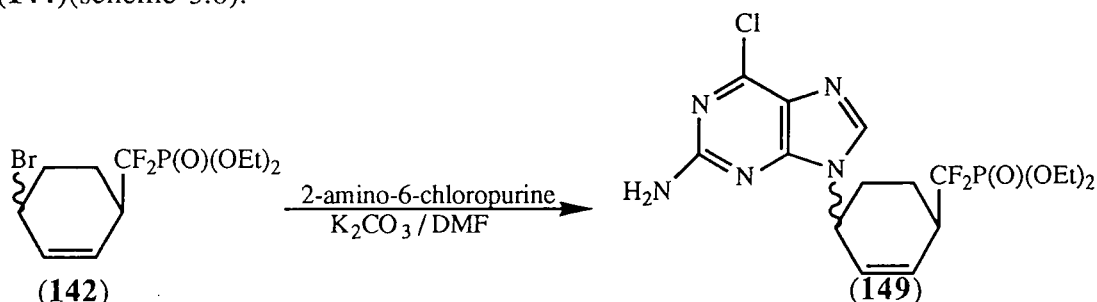

scheme 3.8

However, the yield of the desired product 3-[N9-(2-amino-6-chloropurinyl)]-6-[(diethoxyphosphinyldifluoromethyl)cyclohexene (149), isolated in 31% (based on recovered starting material), was far lower than that for the corresponding 6-chloropurine compound. This can easily be explained by the effect on electron density of the purine ring on addition of the amino group, this raises the conjugate pK_a value of (148), thus 2-amino-6-chloropurine is both a weaker base and poorer nucleophile than 6-chloropurine (144).

The product (149) was obtained as a mixture of isomers, as in the case of the coupling of 6-chloropurine with the bromide (142), the relative ratio of the e'e' and e'a' isomers being 2:3, however, unlike compound (145) these could not be separated by flash column chromatography, even by the variation of the solvent system.

The substitution at N9 was again confirmed by UV spectroscopy, showing no N7 substitution, only characteristic absorptions at 247 and 306nm being apparent for N9 substitution.¹¹⁵ However (148) has a higher proclivity to form N7 substituted

derivatives than (144), figure 3.8 showing that N7 is actually the most nucleophilic nitrogen site. However, as mentioned earlier, steric hindrance by the 6-chloro group disfavors attack at the N7 position.

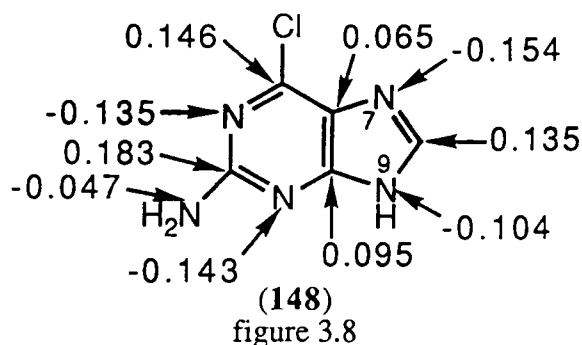

III.D.2.f Synthesis of (±)-3-(N9-Guanyl)-6-[(diethoxyphosphinyl)-difluoromethyl]cyclohexene (150)

The conversion of the 2-amino-6-chloropurinyl residue to the guanyl residue is a facile process accomplished by acid hydrolysis, thus the reaction of (149) with 1M hydrochloric acid was followed by TLC, and terminated after consumption of the starting material. Upon purification by reverse phase chromatography (eluent water) the white solid obtained was not the expected product (150) but rather the monoalkylated ester (151); confirmed by mass spectrometry M^+ 353 (not the expected mass ion peak at M^+ 386), and a broad deuterium oxide exchangeable peak at 4.441ppm on the 1H NMR spectrum.

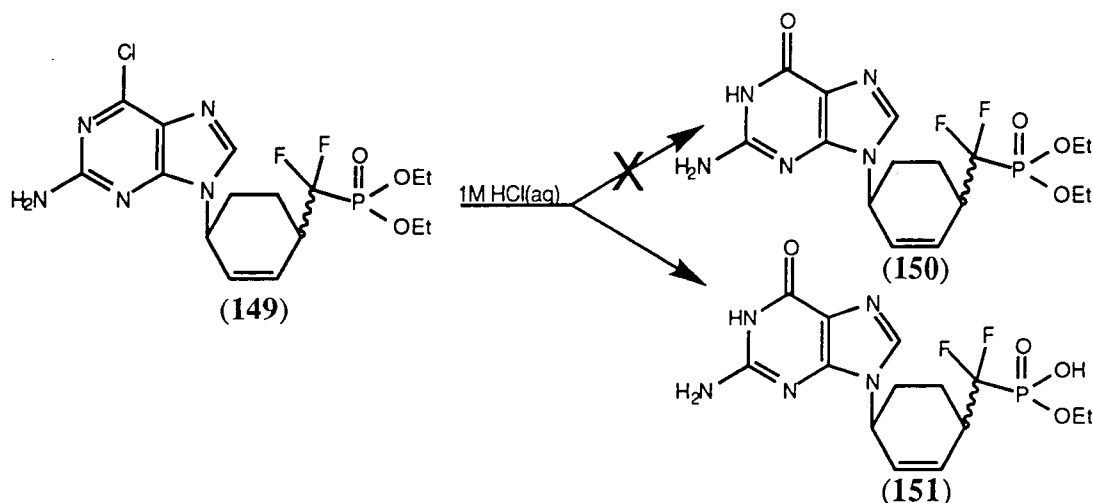

The hydrolysis of one of the ethoxy groups was not unexpected in the acidic conditions utilised, scheme 3.9 showing a possible mechanism for the hydrolysis, 3-(N9-Guanyl)-6-[(ethoxyhydroxyphosphinyl)difluoromethyl]cyclohexene being obtained in a 83% yield.

The alkoxy group is not a good leaving group, so the ester must be converted to the conjugate acid before it can be hydrolysed. This is a facile process for the diester but subsequent hydrolysis of the monoalkoxy ester to the free acid does not occur due to the

difficulty in the protonation step, the equilibrium constant for such a step being very low in the conditions used. Prolonged heating at reflux or a greater acid concentration may have yielded the diacid, however, guanine compounds are acid sensitive undergoing glycoside cleavage.²²³

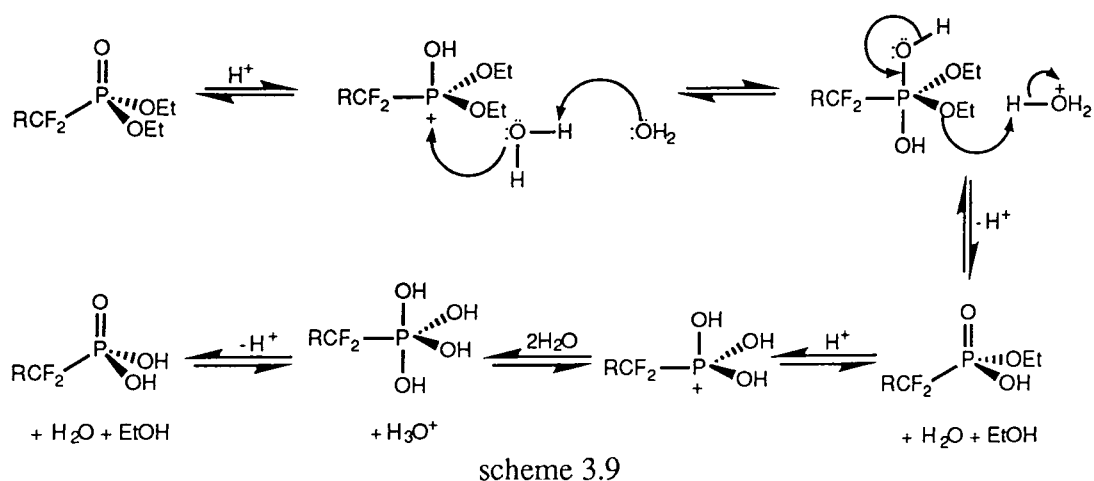

III.D.2.g Deprotection of (\pm)-3-(N9-Guanyl)-6-[(diethoxyphosphinyl)-difluoromethyl]cyclohexene (151)

The removal of the final ethoxy group was accomplished in an analogous manner to that used for the synthesis of (139) except (151) was the starting material to give the fully deprotected nucleotide (140) in a 88% yield, a total overall yield of 18% from 3-[(diethoxyphosphinyl)difluoromethyl]cyclohexene (107).



III.E Biological Test Data on 3-(N9-Adenyl)-6-[(dihydroxyphosphinyl)-difluoromethyl]cyclohexene (139) and 3-(N9-Guanyl)-6-[(dihydroxyphosphinyl)difluoromethyl]cyclohexene (140)

The compounds (139) and (140) are currently under test at SmithKline Beecham Laboratories (Great Burgh) for any *in vitro* antiviral activity.

CHAPTER IV

FREE RADICAL REACTIONS OF (DIETHOXYPHOSPHINYL)- DIFLUOROMETHYLENE HALIDES

IV.A Introduction

The introduction of fluorinated substituents *via* anionic polyfluoroalkylating agents such as Grignard reagents, analogous to those commonly used as alkylating reagents, are generally unsuccessful due to their instability and tendency to decompose. However, this problem has gradually been overcome and can be accomplished utilising metals such as zinc, as discussed in chapters II and III.^{142,159,171} Another alternative for the inclusion of a fluorinated moiety is to add it *via* a radical pathway, *i.e.* by a free radical addition or single electron transfer (SET) pathway, since the generation of polyfluoroalkyl radicals is relatively easy.

Novel routes into the synthesis of (diethoxyphosphinyl)difluoromethylene substituted compounds were explored utilising literature procedures exploiting these two methods.

IV.B Free Radical Addition Processes

The use of a free radical process has many advantages over a route involving nucleophilic displacement with organometallic reagents in that, effectively, hydrogen atoms can be substituted directly by the fluoroalkyl or fluorine containing species.

The free radical addition of perfluoroalkyl halides to alkenes has been a particularly well researched area, because of the wide applications in the synthesis of telomers.²²⁴⁻²²⁶ The initiation processes for the perfluoroalkylation reaction achieved by the utilisation of UV photo-irradiation,²²⁷ thermolysis,^{228,229} organic peroxides²³⁰ and gamma-ray irradiation.

Thus, the free radical addition of (diethoxyphosphinyl)bromodifluoromethane (**94**) and the corresponding iodo derivative (diethoxyphosphinyl)difluoroiodomethane (**118**) to various cyclic alkenes, utilising gamma-ray and UV photo-irradiation, was attempted.

IV.B.1 Utilising Gamma-ray Irradiation

IV.B.1.a The Reaction of Cyclohexene and (Diethoxyphosphinyl)-bromodifluoromethane (94)

The carbon-bromine bond has a bond strength of only $287.4 \pm 6.3 \text{ kJ mol}^{-1}$ ($\text{C}_2\text{F}_5\text{-Br}$)²³¹ and can be easily cleaved by high energy ^{60}Co gamma-ray irradiation to give in the case of (94) a (diethoxyphosphinyl)difluoromethyl radical (152) which could then, in principle, react with an alkene (scheme 4.1).

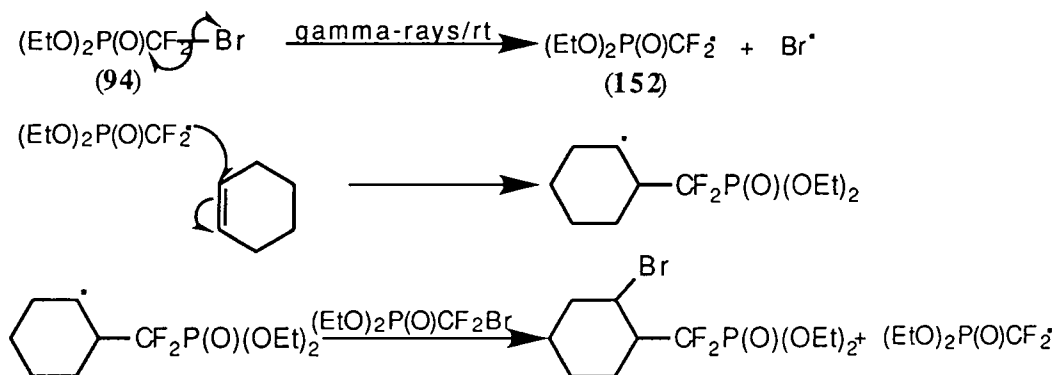

scheme 4.1

Indeed, it has been previously shown that (dialkyl)phosphites react in high yield to give dialkylphosphonate derivatives²³² (scheme 4.2). Therefore, factors such as steric hindrance or homolysis of any other constituent bond in (diethoxyphosphinyl)-bromodifluoromethane (94) or the iodo-derivative (118) should not influence the radical reaction.

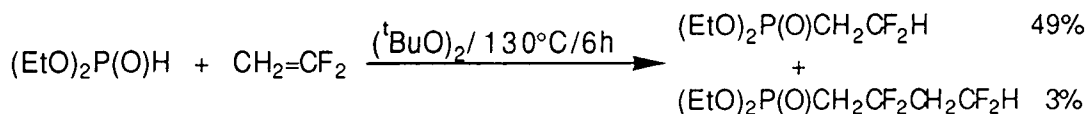

scheme 4.2

When the irradiation of (94) in the presence of cyclohexene was attempted it was found that a free radical addition reaction (scheme 4.3) had been induced by gamma-ray initiation, although only a 25% conversion was realised.

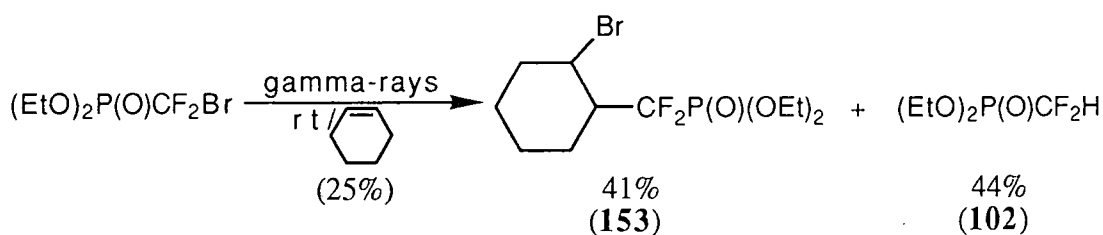

scheme 4.3

The ^{19}F NMR spectrum of the crude reaction mixture showed not only 1-bromo-2-[(diethoxyphosphinyl)difluoromethyl]cyclohexane (153) but also (diethoxyphosphinyl)difluoromethane (102). The fact (102) was the major product of the reaction *via*

hydrogen abstraction raised the question of which route had the hydrogen atom been abstracted.

The (diethoxyphosphinyl)difluoromethyl radical (**152**) could have abstracted a hydrogen from only two sources to form (**102**):

- (i) from cyclohexene;
- (ii) from the starting material (**94**).

The latter would seem more probable due to heteroatom stabilisation of the radical developed upon abstraction of a hydrogen atom from one of the ethoxy groups (scheme 4.4), in an analogous manner to radical stabilisation in ethers.²³³ It was decided to prepare the free acid of (**94**) to deter the formation of the hydrogen abstracted product.

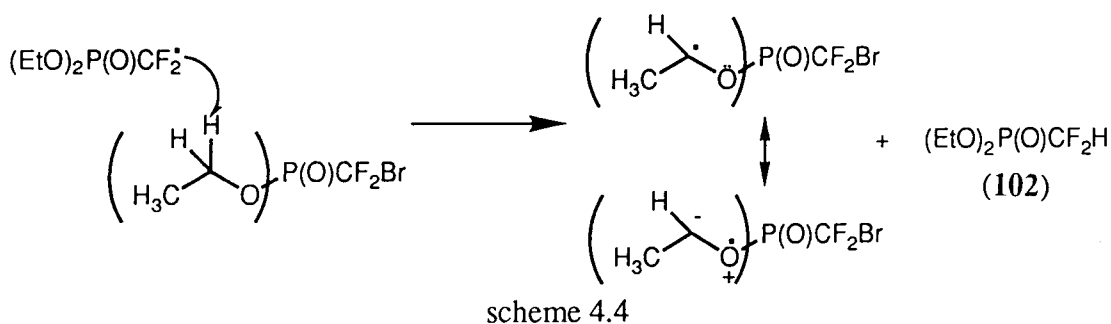

IV.B.1.b The Synthesis of (Dihydroxyphosphinyl)bromodifluoromethane (**154**) and Reaction with Cyclohexene

The starting material (dihydroxyphosphinyl)bromodifluoromethane (**154**) was synthesised from (**94**) in a two step process (scheme 4.5).

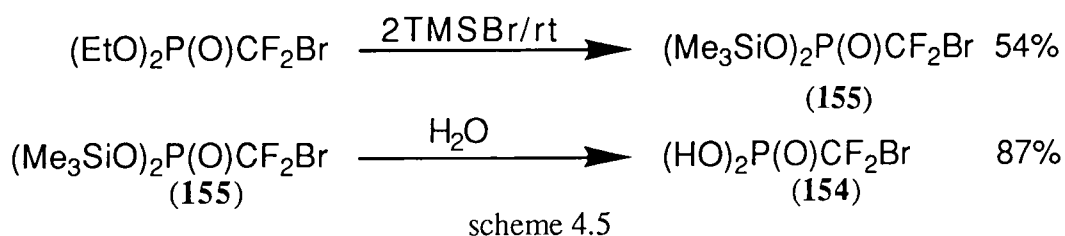

Compound (**94**) was treated with two equivalents of trimethylsilyl bromide (TMSBr)²²² under a nitrogen atmosphere, to afford the silyl ester [bis(trimethylsiloxy)-phosphinyl]bromodifluoromethane (**155**). This was isolated before subsequent hydrolysis, to ensure no contamination of the product by the less volatile monosilylated derivative. The ¹H NMR spectrum showed only 1 peak at 0.002ppm due to the 6 equivalent methyl protons. Hydrolysis yielded the free acid (**154**), a viscous hygroscopic liquid.

The acid was immiscible in cyclohexene, and 1,1,1-trifluoroethanol was used as a solvent. After irradiation and subsequent work-up the ^{19}F NMR spectrum indicated the presence of [(dihydroxyphosphinyl)difluoromethyl]cyclohexane (**156**) and, again, the hydrogen atom abstracted product (dihydroxyphosphinyl)difluoromethane (**157**) (scheme 4.6). Although the ratio of the two products had now swung in favour of the radical addition product (**156**).

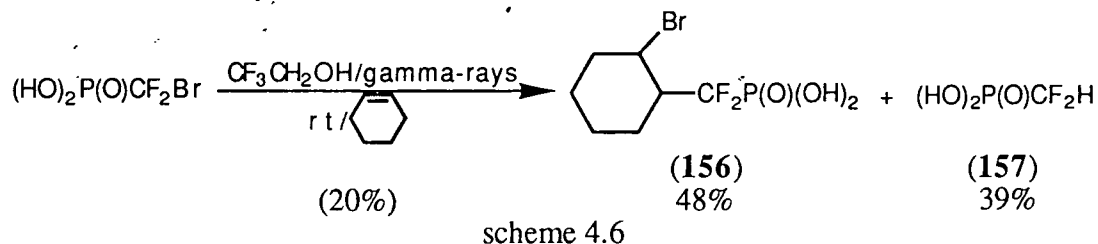

It can be concluded, therefore, that the conversion of the ethoxy groups present in (**94**) to hydroxyl groups did reverse the relative ratio of the radical addition product to cyclohexene over that of the radical abstracted product. However, a significant amount of the hydrogen abstracted product, *i.e.* (**102**) or (**157**), was still present. The majority of the abstracted hydrogen atoms must have come from cyclohexene or possibly 1,1,1-trifluoroethanol. However, experiments conducted by Walling²³⁴ and independently by Chambers²³⁵ demonstrated a decrease in the relative rate of hydrogen abstraction for *tert*-butoxy radicals with an increased number of electron withdrawing substituents, therefore, it seems unlikely hydrogen atoms had been abstracted from 1,1,1-trifluoroethanol. Indeed the results of Walling showed cyclohexene readily loses a hydrogen atom to generate an allylic stabilised radical.²³⁴ Furthermore, 1,1,1-trifluoroethanol is widely used in our laboratory for radical reactions as a solvent, implying a low reactivity to radical processes. Hence scheme 4.7 reflects the most probable mechanism for hydrogen abstraction.

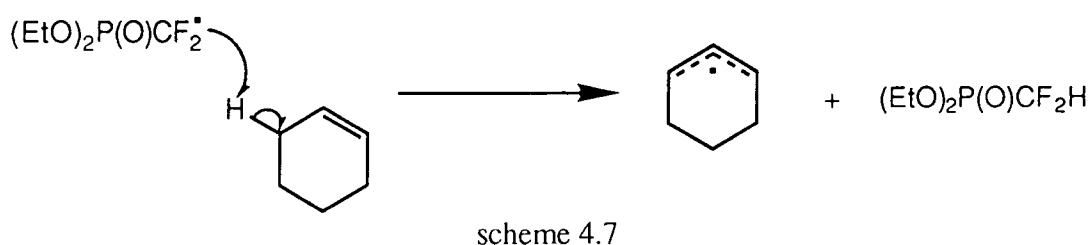

IV.B.1.c The Stereochemistry of the Addition of (Diethoxyphosphinyl)-bromodifluoromethane (**94**) to Cyclohexene

The radical addition to cyclohexene must proceed *via* the intermediate radical (**158**). The e.s.r. spectra of a variety of cyclohexyl radicals are consistent with rapidly interconverting chair conformers with a planar radical centre.²³⁶ Therefore, the possibility exists for the radical centre to abstract a halogen atom which may go on either face of the cyclohexene ring, the trigonal radical centre destroying any possibility of

stereochemical control.²³⁷ However, results have shown that the abstraction of the halide atom to regenerate the (diethoxyphosphinyl)difluoromethyl radical (**152**) tends to favour an equatorial approach to yield the *trans*-isomer (**153a**) over the *cis*-isomer (**153b**) (ratio 3:2 respectively). This outcome is probably due to the reduction in steric crowding on the formation of the *trans*-isomer as opposed to the *cis*-isomer, given diequatorial substitution represents the more thermodynamically stable product (scheme 4.8).

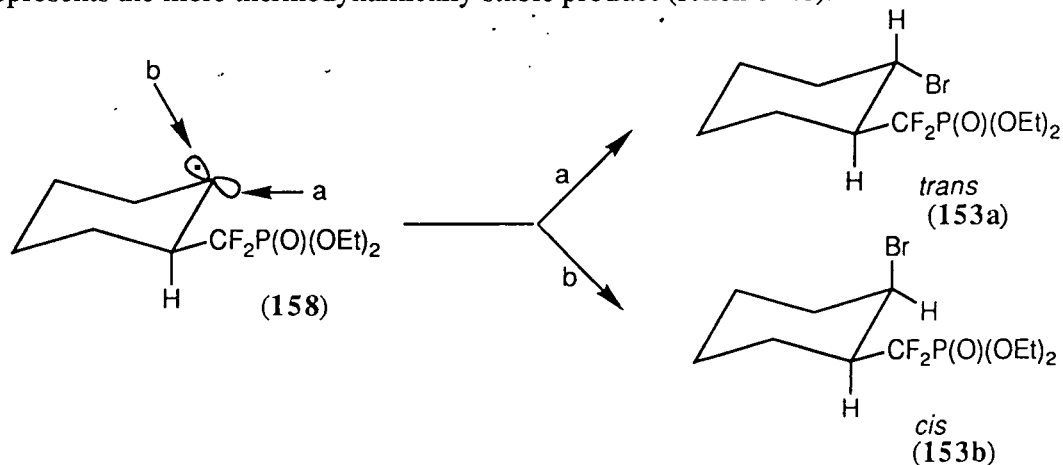

scheme 4.8

This selectivity is revealed in the ^{19}F NMR spectra of the compounds (**153a**) and (**153b**), thus table 4.1 shows the different couplings for the two isomers which compare well with the literature values for the iodo derivative synthesised by Burton *et al.*²³⁸

Isomer	$^2J_{\text{FF}}$ (Hz)	$^2J_{\text{FP}}$ (Hz)	$^3J_{\text{FH}}$ (Hz)
<i>cis</i>	302.2	110.7	26.4
	302.0	110.7	21.6
<i>trans</i>	300.0	110.0	19.8
	304.1	110.1	21.6

Coupling Constants for *cis*- and *trans*- 1-Bromo-2-[(diethoxyphosphinyl)difluoromethyl]cyclohexane
table 4.1

IV.B.2 Utilising Ultraviolet Irradiation

The fission of chemical bonds using UV radiation is a direct method of producing free radicals. The radicals are generally produced as highly excited entities with excess kinetic energy, in a greater quantity than *via* gamma-ray irradiation due to the limited interaction of gamma-rays with matter. Since carbon-halogen (bromine or iodine) bond strengths are relatively weak *i.e.* less than 300kJmol^{-1} these tend to cleave first. However, the actual production of radicals from photoexcited molecules is a multi-step process. Absorption of energy results in the initial excitation of σ , n , or π electrons to the excited σ^* or π^* state in which electrons are paired. This excited state normally contains an excess of vibrational energy which is rapidly dissipated and thereafter one of the following takes place:²³⁹

- (i) radiation is emitted (fluorescence) and the molecule returns to the ground state;
- (ii) energy is lost by collision with the solvent;
- (iii) the excited singlet state may undergo intersystem crossing to an excited triplet state, provided there exists a triplet state of the appropriate energy and then phosphoresce;
- (iv) homolysis can occur, giving a radical pair in which the electron spins are anti-parallel. The triplet state may undergo homolysis, in which case radicals with unpaired spins would be produced.

To aid absorption of UV radiation a photo-sensitizer was used in all cases. These compounds contain a chromophore, *e.g.* the carbonyl functionality which absorbs UV radiation strongly and undergo a facile n to π^* transition. The energy of the excited photo-sensitizer (D) can then be transferred to an acceptor molecule (A) promoting this to the excited state (figure 4.1).

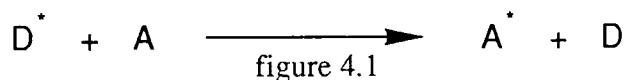

In most cases acetone was used as both the solvent and photo-sensitizer,²⁴⁰ however, comparative studies were made with benzophenone, a very efficient photo-sensitizer.²⁴¹

IV.B.2.a The Reaction of Cyclohexene and (Diethoxyphosphinyl)-bromodifluoromethane (94)

Given the higher energy of free radicals generated by UV photolysis it seemed reasonable to react cyclohexene with (94), to afford a higher yield of the desired product (153). The reaction was set up in an analogous manner for gamma-ray irradiation. However, the tube was irradiated for 72 hours, with a medium pressure 1kW mercury vapour lamp. It was noted that during the experiment heating of the contents was unavoidable and at extremes reached upto 50°C, so temperature effects may also have enhanced reaction rates.

A ¹⁹F NMR spectrum of the crude mixture showed an increase in the conversion of the bromide (94) to the desired product (153) as well as the ubiquitous hydrogen abstraction product (102)(scheme 4.9), compared to the analogous gamma-ray initiated reaction.

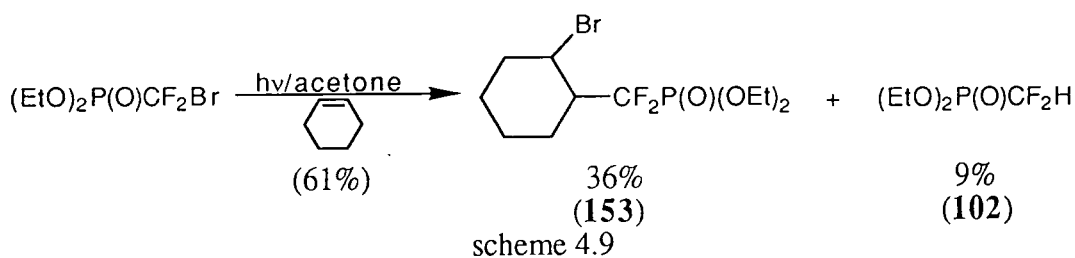

Unlike gamma-ray initiated reaction the ratio of 1-bromo-2-[(diethoxyphosphinyl)difluoromethyl]cyclohexane (**153**) to that of (**102**) was 4:1, indicative of the more energetic (diethoxyphosphinyl)difluoromethyl radicals (**152**) undergoing radical addition to cyclohexene at a faster rate than the hydrogen abstraction process. Note the increase in the proportion of (**153**) could also be due to some excitation of the alkenyl π -electrons. The isomeric ratio for (**153**), *i.e.* *trans* to *cis*, was 3:2 respectively, the *trans*-isomer again dominant.

A repeat of the above experiment with benzophenone as the photo-sensitiser, and no solvent, resulted in both a lower conversion to products (27%) and ratio of the addition product (**153**) to (**102**) (2:1 respectively)(data accrued from comparison of ^{19}F NMR spectra).

The utilisation of UV photolysis appears, therefore, to give a higher conversion for a similar time period than if the same reactants were exposed to gamma-ray irradiation. This is due to the combination of:

- (i) a greater radical flux as a result of exposure to UV irradiation;
- (ii) the excess of kinetic energy these 'hot' radicals possess;
- (iii) the unavoidable temperature rise associated with UV irradiation (a rise in temperature of 10°C approximately increases the rate of a reaction two-fold; Arrhenius equation³¹).

IV.B.2.b The Reaction of Cycloalkenes and (Diethoxyphosphinyl)-difluoroiodomethane (118)

Given the weaker carbon-iodine bond, *i.e.* $214.2 \pm 4.2\text{kJmol}^{-1}$ ($\text{C}_2\text{F}_5\text{-I}$),²⁴² compared to the carbon-bromine bond it seemed appropriate to repeat the reaction of cyclohexene with the iodide (**118**). It was first necessary, however, to synthesise this compound. Burton has described a facile procedure for the synthesis of (**118**) from (**94**), the literature procedure¹⁴² (scheme 4.10) was followed to afford the clear pale yellow liquid (**118**).

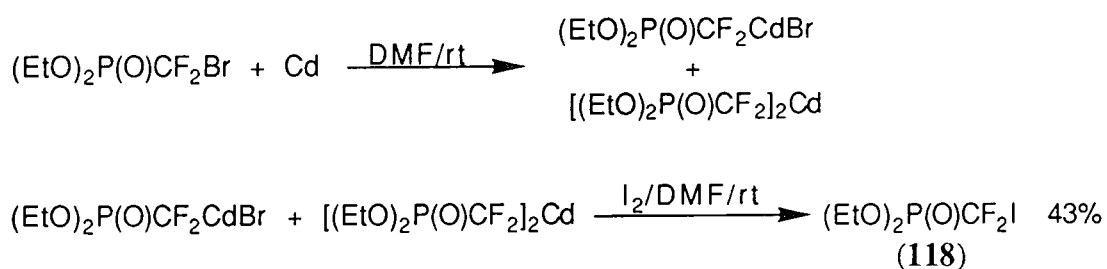

scheme 4.10

The iodide (**118**) was then reacted with cyclohexene under identical conditions to that used for the bromide (**94**)(scheme 4.11).

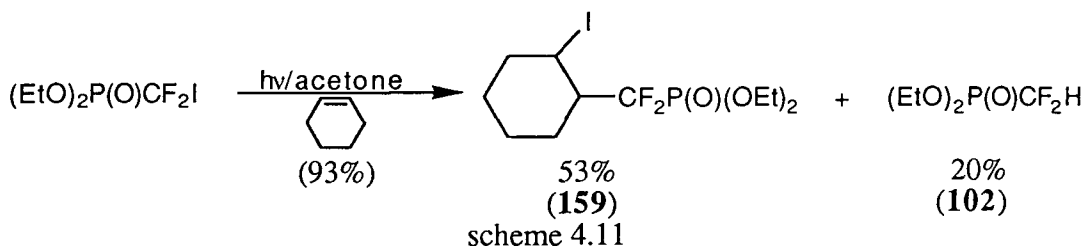

The radical reaction of the iodide (**118**) gave 1-[(diethoxyphosphinyl)-difluoromethyl]-2-iodocyclohexane (**159**) and the hydrogen abstracted material (**102**). The conversion of the iodide (**118**) had risen from the 61% obtained with the bromide (**94**) under identical conditions. This is probably due to the weaker carbon-halogen bond strength. However, the ratio of (**159**) to (**102**) was not as favourable, probably due to the more energetic and hence less selective nature of the (diethoxyphosphinyl)difluoromethylene radicals generated from the iodide (**118**). The ratio of the *cis*- to *trans*- products was approximately 3:2 in favour of the *trans*-product comparable to the previous experiments with the bromide (**94**).

Given the success of the iodide (**118**) with cyclohexene other cycloalkenes were tried (table 4.2).

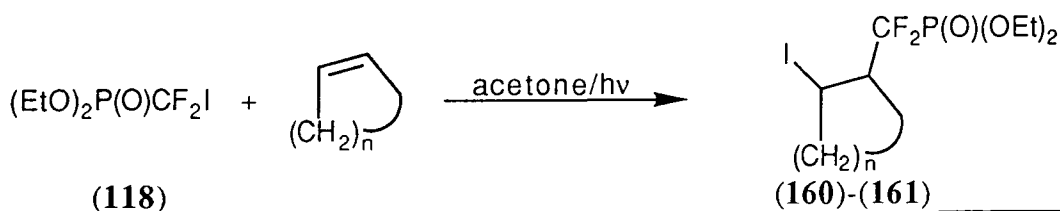

n	Product	Conversion (%)	Yield (%)
2	(160)	70	34
4	(161)	86	67

table 4.2

The assignment of the relative dispositions of the iodo and (diethoxyphosphinyl)difluoromethylene groups in the cyclopentene ring could not be ascertained from the ^1H NMR spectrum of (**160**) due to the almost planar nature of the ring leading to coupling constants for both the *cis*- and the *trans*-isomers of between 0-7Hz, more typically in the region of 4-5Hz.¹⁶² The ^{19}F NMR spectrum on the other hand showed only one set of resonances due to the difluoromethylene group, unlike the cyclohexane derivative (**159**). Figure 4.2 shows the fluorine coupling constants for the cyclopentene derivative.

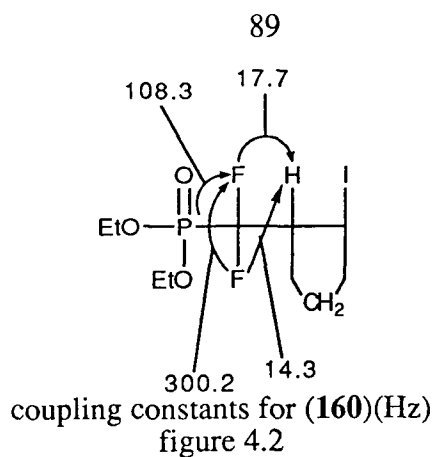

For the cycloheptane substituted compound **(161)** once again only one isomer was evident for which the coupling constants could be assigned from the ^{19}F NMR spectrum (figure 4.3).

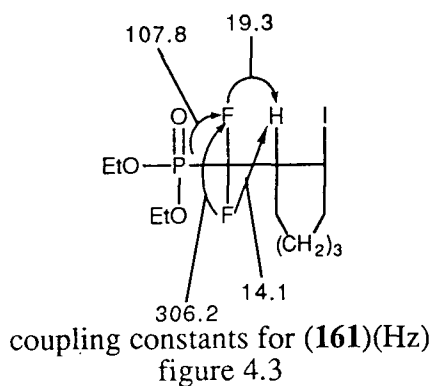

IV.B.2.c The Reaction of Furanyl Systems with (Diethoxyphosphinyl)-difluoroiodomethane (118)

The possibility of inserting a (diethoxyphosphinyl)difluoromethyl moiety directly into a heterocycle is of interest. Therefore, a study was undertaken to investigate the reaction of various furan derivatives with **(118)**.

The experimental procedure followed for the furan derivatives was the same as that described for the cycloalkanes and the furans used are indicated in the table 4.3.

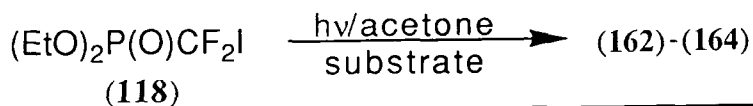

Entry	Reactant	Conversion (%) [†]	ratio of product to (102)
(162)		0	-
(163)		4	1:1
(164)		2	1:1

Reaction of (diethoxyphosphinyl)difluoroiodomethane and furan derivatives.
table 4.3

[†] Conversion based on ^{19}F NMR data

The table shows that although a reaction occurred between 2,5-dihydrofuran, or furan itself, with the iodide (118) no reaction was observed with 2,3-dihydrofuran. The resulting crude reaction mixtures after exposure to UV initiation were very discoloured and the conversion of the iodide (118) to the coupled product was less than 5% in the two furanyl systems which did react. No products could be isolated by distillation from the mixtures, thus, all data had to be interpreted from ^{19}F NMR spectra.

The furan derivatives should have been more reactive towards radical addition of (118) given the possibility of stabilisation of the intermediate radical centre generated by the lone pairs available on the oxygen atom. However, this is clearly not the case, given that 2,3-dihydrofuran did not afford any addition product with (118). Low conversion and discolouration could be due the liberation of iodine or more likely the polymerisation of the furan derivatives, which undergo a number of photochemical rearrangements, as well as, dissociation and polymerisation. This results in a wide product distribution.²⁴³

IV.C S.E.T. Processes

IV.C.1 Palladium (0) Catalysed Coupling

It has been known for some time that iododifluoroacetates undergo an addition-reduction process to provide α,α -difluoroesters in the presence of a copper catalyst,²⁴⁴ Burton and Yang thus proposed that (diethoxyphosphinyl)difluoroiodomethane (118) would undergo an analogous addition-reduction process to yield α,α -(diethoxyphosphinyl)difluoromethylene derivatives.¹⁷⁰ Indeed, this was the case for various terminal alkenes, which could include such functionalities as epoxy, carbonyl and hydroxy. These substrates reacted with the iodide (118) in yields upto 91% in the presence of a palladium (0) catalyst *e.g.* tetrakis(triphenylphosphine)palladium (scheme 4.12).

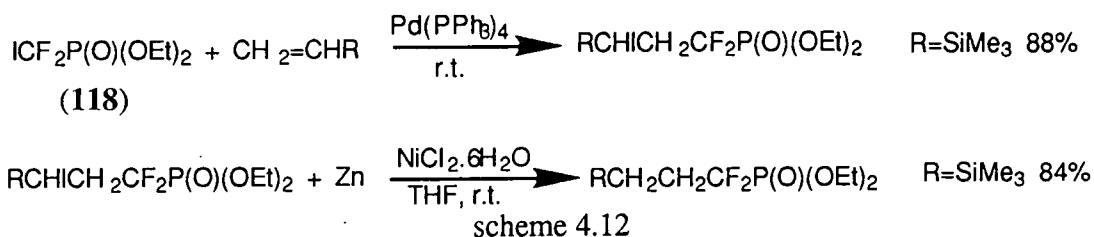

However, the catalyst system used could not introduce (118) into cyclic alkenes.

IV.C.2 Copper Catalysed Coupling of (Diethoxyphosphinyl)-difluoroalides to Cycloalkenes

Burton *et al.*²³⁸ recently established that copper metal could effect the addition to cyclic alkenes of (118), thus Burton facilitated the addition of (118) to cyclohexene in

69% yield both with and without solvent, the hydrogen abstracted product (**102**) formed as a by-product (scheme 4.13).

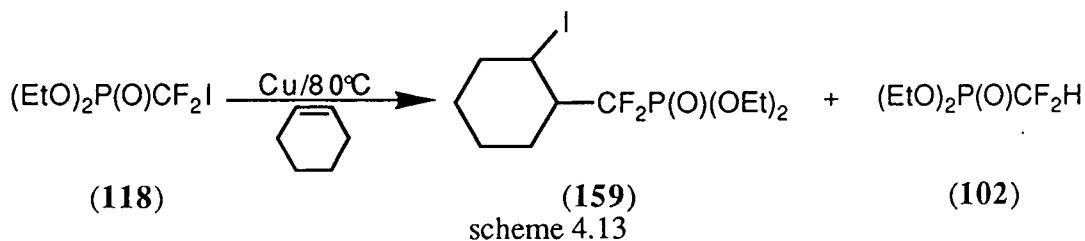

We had previously attempted the addition of (**94**) to cyclohexene (scheme 4.14) but found the reaction to be unsuccessful.

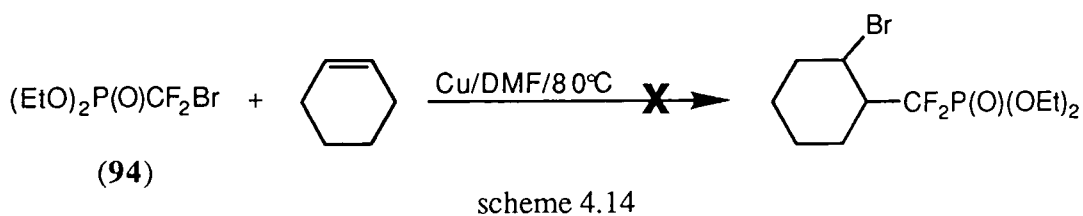

The lack of reactivity for the bromide (**94**) can only be ascribed to the stronger carbon-bromine bond, the carbon-iodine bond having an energy of only $214.2 \pm 4.2 \text{ kJ mol}^{-1}$, since the steric differences between (**94**) and (**118**) are minimal.

IV.C.3 Samarium Diiodide Catalysed Coupling of (Diethoxyphosphinyl)-difluorohalides to Cycloalkenes

IV.C.3.a Attempted Reaction of (Diethoxyphosphinyl)bromodifluoromethane (**94**) with Cyclohexene

Samarium diiodide was found to be an effective initiator in the addition of fluoroalkyl iodides to both alkenes²⁴⁵ and alkynes²⁴⁶ (scheme 4.15).

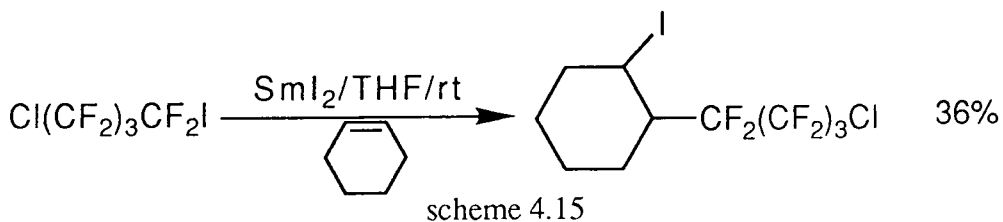

A study was undertaken to explore the above method as a route to add (diethoxyphosphinyl)bromodifluoromethane (**94**) across the double bond of cyclohexene *via* a SET mechanism (scheme 4.16).

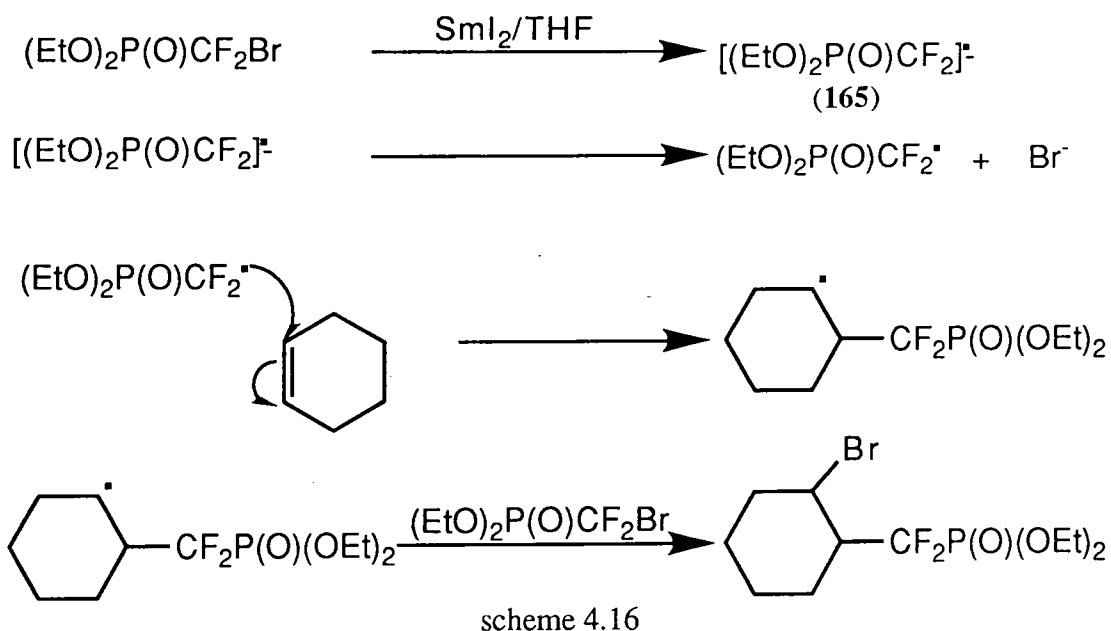

The addition of a catalytic amount of samarium diiodide in oxolane to a solution of bromide (94) and cyclohexene resulted in a striking colour change, due to the oxidation of samarium diiodide. However, the ^{19}F NMR spectrum indicated no reaction (scheme 4.17). The next step, therefore, was to attempt the reaction with the iodide (118).

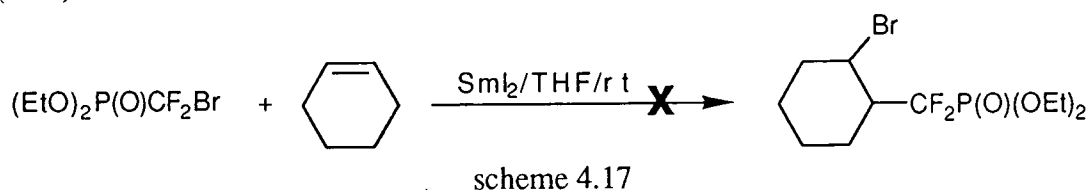

IV.C.3.b Attempted Reaction of (Diethoxyphosphinyl)difluoroiodomethane (118) with Cyclohexene

To a solution of the iodide (118), synthesised as previously described, and cyclohexene in THF was injected a catalytic quantity of samarium diiodide solution (THF). Again a colour change was observed from blue to colourless, characteristic of the oxidation of the samarium diiodide to the triiodide. It was evident from the ^{19}F NMR spectrum, however, that no reaction had taken place between (118) and cyclohexene (scheme 4.18).

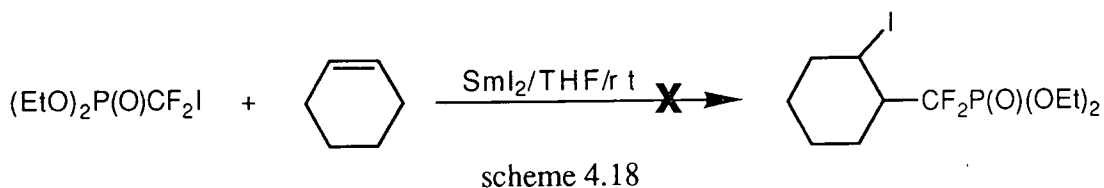

IV.C.3.c Conclusion

Although samarium diiodide has proved an excellent means for the coupling of polyfluoroalkyl iodides to alkenes it proved ineffective at coupling (diethoxyphosphinyl)difluorohalides to cyclohexene. This could be due to the electrode potential of the transformation illustrated²⁴⁷ in figure 4.4 being insufficient to generate the radical anion (**165**).

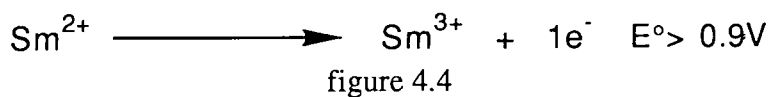

Steric reasons for the inhibition of the reaction can not be ruled out, however, it should be noted that both the reactions involving irradiation as a means of generating the radical (**152**) and the SET copper catalysed addition of the iodide (**118**) to cyclohexene requiring the input of high energies either by elevated temperature or irradiation to yield products unlike the samarium diiodide route.

CHAPTER V

THE SYNTHESIS OF PURINE AND PYRIMIDINE POLYFLUORO-NUCLEOSIDES

V.A Introduction

5-Fluorouracil (**166**) was synthesised and developed as an antimetabolite by Danenberg *et al.*⁴² (scheme 5.1), in 1957, on the premise that tumour cells showed increased utilisation of uracil, needed for the production *in vivo* of thymine. They expected (**166**) to be incorporated into RNA but not DNA, and also to inhibit DNA biosynthesis, because the firmly bonded fluorine atom at C5 prevents attachment of the one carbon unit to the C5 position that becomes the methyl group of thymine.

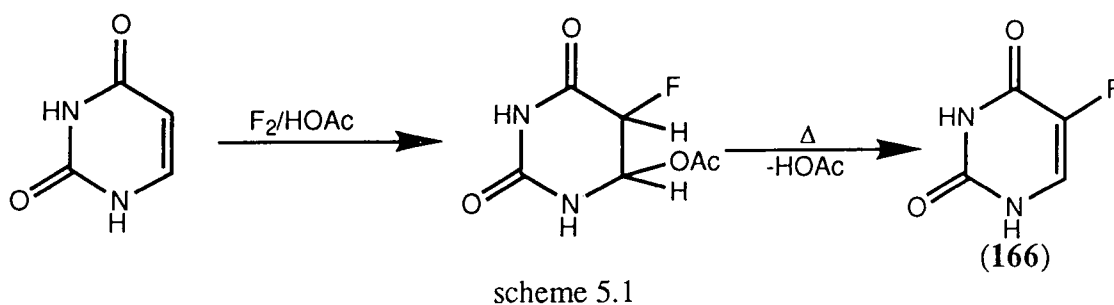

The action of 5-fluorouracil *in vivo* is *via* two pathways:

- (i) conversion to the 5-fluoro-deoxyuridine monophosphate (**167**) a potent 'suicide inhibitor' of the enzyme thymidylate synthetase;
- (ii) conversion to 5-fluorouridine monophosphate (**168**), which is further incorporated into RNA, this leads ultimately to transcription errors in later cellular processes.¹⁸

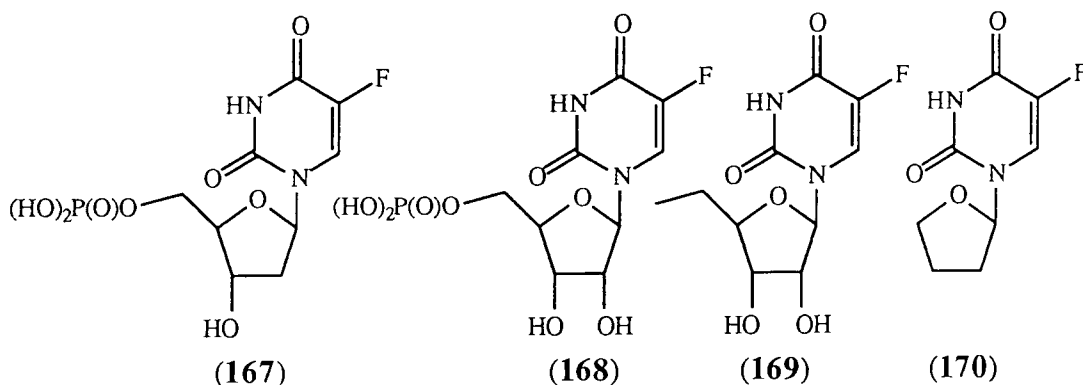

5-Fluorouracil and its anabolic metabolites (**167**) and (**168**) have, thus, been used clinically for cancer treatment but have the disadvantage of both high toxicity and requirement for high dosage. This fact has led to the synthesis of a variety of prodrugs for (**166**) obviating these toxicological problems, of which 5'-deoxy-5-fluorouridine (**169**)²⁴⁸ and 5-fluoro-1-(tetrahydro-2-furyl)uracil (**170**) show the most promise.

V.B 5'-Deoxynucleoside Derivatives of 5-Fluorouracil

Russian workers effected the synthesis of (170) in 1969,²⁴⁹ and more recently Earl *et al.*²⁵⁰ devised a new route to (170) and the pyranyl derivative (171) *via* fluorination of the corresponding uracil derivatives with trifluoromethyl hypofluorite (scheme 5.2). The 5'-deoxynucleosides (169) and (170) demonstrated superior activity over (166), apparently because of greater specific toxicity for the tumour compared to potentially susceptible host cells and the inability of the nucleoside analogues to be phosphorylated to nucleotides.²⁵¹

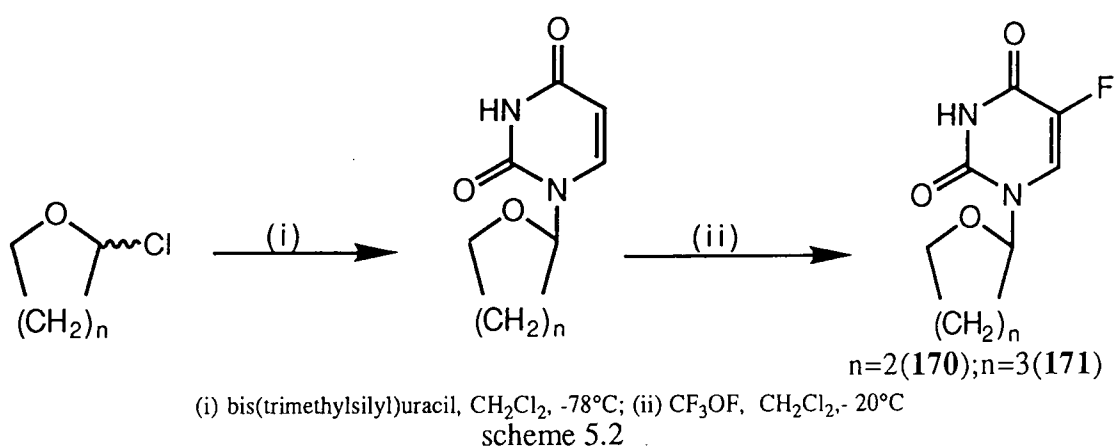

The mode of action of these derivatives is that of hydrolytic cleavage *in vivo* of the glycosidic linkage by thymidine phosphorylase,²⁵¹ thus yielding 5-fluorouracil which can be metabolised by the methods described earlier (section V.A).

Further alterations are possible, Danenberg *et al.*⁹³ introducing a fluoro group in the C4' position of the sugar moiety to give the 5-fluorouracil prodrug (53) (section I.C.3.c). Modification at the C4' position in the sugar ring decreases hydrolytic stability in acidic conditions due to the presence of the electron withdrawing fluoro group, thus Danenberg rationalised, that if the action of uridine phosphorylase involves an acid catalysed step to release 5-fluorouracil from such prodrugs as (53) or (170), then 5-fluorouracil would be cleaved at an accelerated rate from (53). Indeed, this proved to be the case.

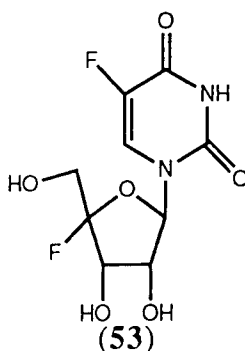

It therefore appeared to be an ideal opportunity to develop C5' substituted analogues of (170) containing a lipophilic polyfluoroalkyl substituent known to increase transport of drugs across lipid membranes.³⁹

V.C Free Radical Formation of Polyfluoroalkyl Ethers

The first step in the synthesis of new 5-fluorouracil prodrugs involved the attachment of a polyfluoroalkyl group to the sugar skeleton *via* a free radical process. This field of work, essentially the radical addition of ethers to polyfluoroalkenes has been extensively covered by Chambers *et al.*,^{235,252-254} and utilises the carbon-hydrogen bond in ethers as a functional group.

In the free radical reaction of fluoroalkenes with an ether (scheme 5.3) the initiation step, *i.e.* the homolytic cleavage of a carbon-hydrogen bond to form two radicals, was induced by ⁶⁰Co gamma-ray irradiation without exception (reactions occur at room temperature, produce little or no side products, and the products are readily isolated); sources of initiation used previously in the free radical reaction of ethers and fluoroalkenes have included peroxides^{252,254} and UV photolysis.^{254,255}

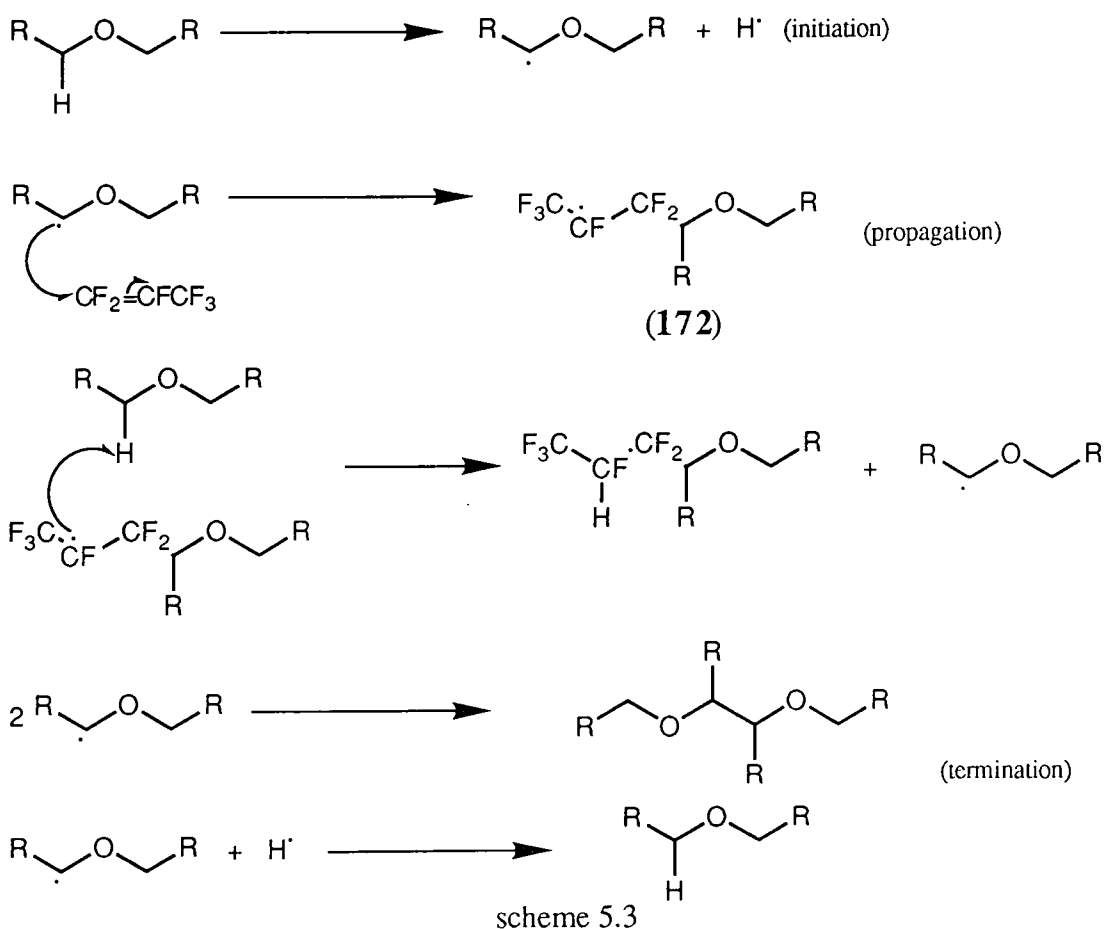

In the propagation steps of the reaction it can be seen that two processes occur:

- (i) attack of a nucleophilic radical on the electron deficient fluoroalkene double bond to give (172);
- (ii) proton abstraction by (172) at the carbon-hydrogen bond alpha to oxygen.

These two steps can be rationalised.

V.C.1 Factors Affecting Regiochemistry and Stereochemistry of Free Radical Addition

The dominant force for the regiochemical direction of the free radical addition of fluoroalkenes to ethers can be attributed to two factors, the stabilisation of the radical centres generated and stereoelectronic effects.

In the generation of the radical (172) attack occurs at the difluoromethylene site of the alkene; NMR experiments indicate no evidence of attack at the internal vinylic fluorine site. This fact can be explained by a combination of:

- (i) steric hindrance of the attacking nucleophilic radical, minimised by attack at the least hindered site of the alkene *i.e.* the difluoromethylene group. Reinforced by the electronic effect, the difluoromethylene site constituting the most electron deficient vinylic site;
- (ii) stabilisation of the new radical centre, remote and near stabilisation of the radical centre is maximised by generation of the radical at the internal vinylic fluorine centre, demonstrated theoretically²⁵⁶ and experimentally.²⁵⁷

The fluoroalkyl ether radical (172), could in theory react with another molecule of fluoroalkene but hexafluoropropene does not homopolymerise, rather the radical attacks the ether at the site alpha to oxygen generating a heteroatom stabilised radical centre.²³³ Indeed, molecular orbital calculations by Hudson *et al.*²³³ have shown a high degree of stabilisation of the singly occupied molecular orbital by the oxygen lone pair represented diagrammatically in figure 5.1.

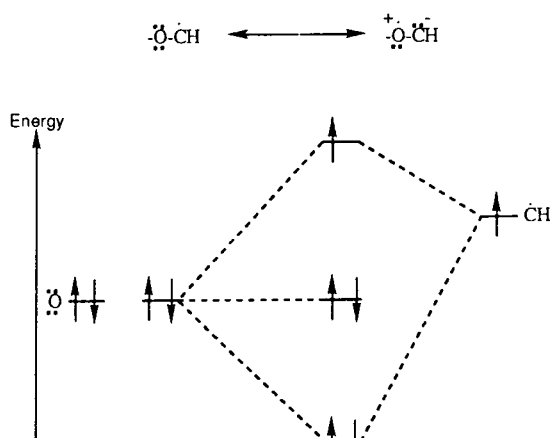

figure 5.1

When the generation of a radical centre takes place at a chiral or prochiral carbon, loss of stereochemical control is almost always observed, because free radicals do not retain their configuration except under certain circumstances *e.g.* cyclopropyl substrates which show both retention²⁵⁸ and inversion²⁵⁹ and *via* neighbouring group participation.²⁶⁰

Thus in the formation of the mono-adducts between fluoroalkenes and ethers the fluoromethyl position and, if the ether is cyclic, at the newly generated chiral centre adjacent oxygen, would be predicted to be a mixture of stereoisomers (approximately 50:50). However, some stereoselectivity is observed *e.g.* in the reaction of hexafluoropropene with oxolane, discussed later in this chapter (section V.C.3.b).

V.C.2 Acyclic Fluorinated Ethers

Dimethyl ether has previously been reacted with hexafluoropropene to give exclusively the monoadduct, by ^{60}Co gamma-ray irradiation.²⁶¹ This work was repeated, together with some other fluoroolefins, to build up a series of short chain acyclic polyfluoroethers to ultimately yield nucleosides with a similarity to acyclovir (**55**), bearing a fluoroalkyl rather than a hydroxy substituent.

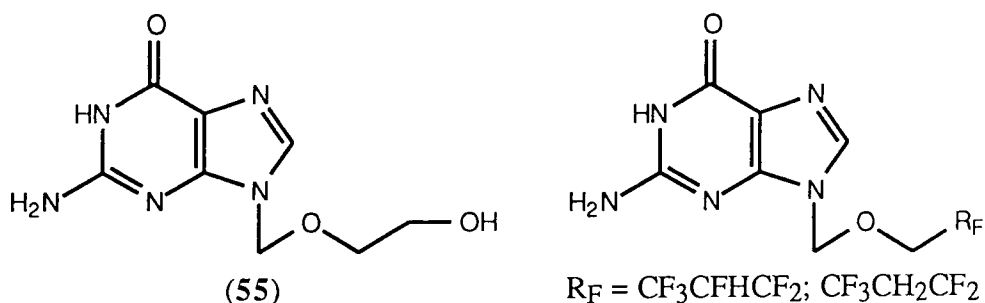

The yield of the hexafluoropropene adduct (**173**), 79%, was comparable to that obtained previously,²³⁵ and identification by NMR spectrometry confirmed the structural assignment of a monoadduct with a difluoromethylene group beta to oxygen, the alpha hydrogens showing coupling characteristic of an adjacent difluoromethylene group (figure 5.2).

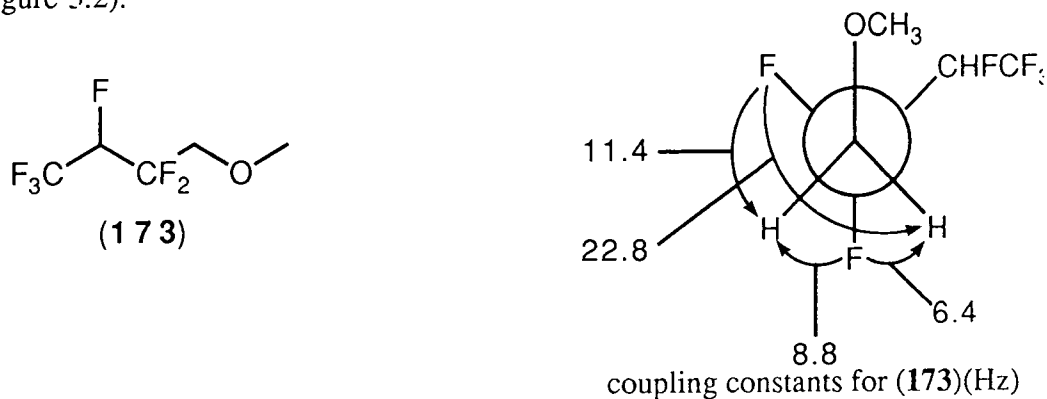

figure 5.2

1,1,3,3,3-Pentafluoropropene, however, gave methoxy-1,1,3,3,3-pentafluorobutane (**174**)(figure 5.3) in a 58% yield, a significant drop in reactivity, almost half of the 1,1,3,3,3-pentafluoropropene being recovered. The large difference in reactivity was not expected given the only difference between the two fluoroalkenes is the presence of a vinylic hydrogen in 1,1,3,3,3-pentafluoropropene.

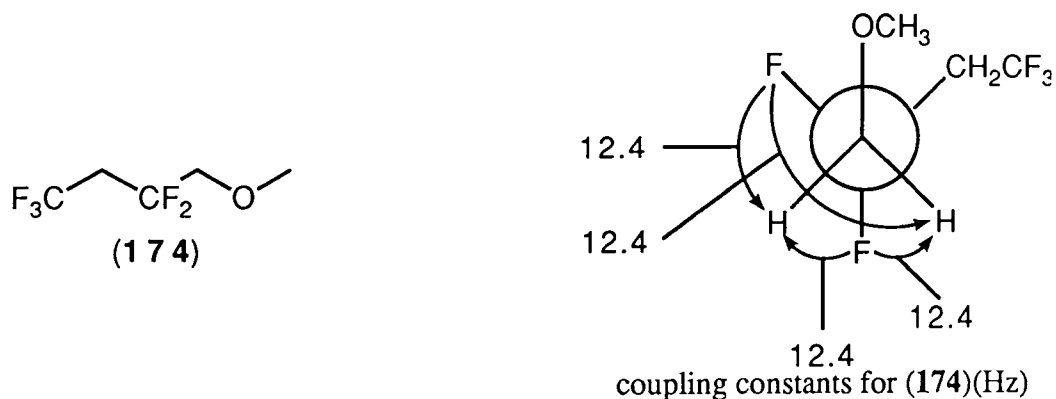
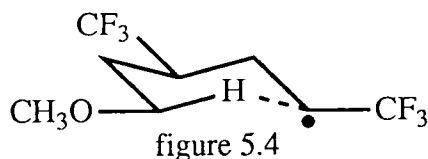

figure 5.3

The ^1H NMR spectrum for (174) contrasted dramatically with that for the adduct (173), in (174) both the methylene protons and the two difluoromethylene fluorine atoms were equivalent. Thus, a triplet was observed ($^3J_{\text{FH}} = 12.4\text{Hz}$) for the coupling of the difluoromethylene group to the methylene group. However, Methoxy-2,2,3,4,4,4-hexafluorobutane (173) gave a complex splitting pattern (ABddd) due to the inequivalence of the methylene protons and the difluoromethylene fluorine atoms. This can be rationalised by the presence of the extra fluorine atom at the 2-position which would prefer to be eclipsed relative to the two difluoromethylene fluorine atoms (lone pair repulsion) which gives rise to a preferred low energy conformation.

When 3,3,3-trifluoropropene was reacted with dimethyl ether, an even more anomalous result was observed. No fluoroalkene was recovered and the only product was a very viscous liquid (175). This liquid proved to be of a high molecular weight $M_R > 500$ (by FAB mass spectrometry) indicative of telomerisation. This has been previously reported for 3,3,3-trifluoropropene in the radical addition to oxolane, by Bergstrom,²⁶² the telomerisation initiated by peroxides present in the ether. Indeed, stringent conditions had to be adopted by Bergstrom to obtain the mono-adduct in isolation. However, gamma-ray initiation even with a vast deficiency of the alkene still yielded polymeric products, presumably due to a similar runaway telomerisation process (scheme 5.4); the [1,5]-hydrogen shift proceeding *via* a chair transition state (figure 5.4).



The table clearly shows an order of reactivity thus:

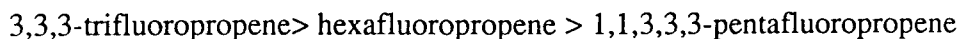

Explanations as to why the reactivity is so are put forward:

i) Steric - 3,3,3-Trifluoropropene is sterically less hindered at the carbon site under attack than either hexafluoropropene or 1,1,3,3,3-pentafluoropropene;

ii) Electronic - It is well known that a radical centre is stabilised by fluorine atoms,²⁵⁷ thus greater stabilisation of the radical centre on the C2 carbon occurs in hexafluoropropene, where there is one fluorine atom compared to 1,1,3,3,3-pentafluoropropene and 3,3,3-trifluoropropene which have only hydrogen at C2. The trifluoromethyl group is common to all three fluoroalkenes, therefore, the effect of this group can be neglected;

iii) Deactivation due to fluorine - Mono-adducts show low reactivity towards fluorinated alkenes, because of the electron withdrawing effect of the polyfluoroalkyl group reducing the ability of the oxygen lone pairs to stabilise the radical centre.²⁶³ However, energetically hydrogen abstraction to generate a primary radical centre is greater than to generate a secondary radical centre. Thus, in the adduct between 3,3,3-trifluoropropene and dimethyl ether (figure 5.5) where one trifluoromethyl group is present and three secondary sites are generated, the methylene group adjacent to oxygen is far enough away from the deactivating trifluoromethyl group that it seems conceivable (175) is as reactive or more reactive than dimethyl ether, which has only primary hydrogens, hence telomerisation. For the other mono-adducts (173) and (174) the proximity of the difluoromethylene group must deactivate the oxygen to a much greater extent, hence no telomerisation or di-adduct formation.

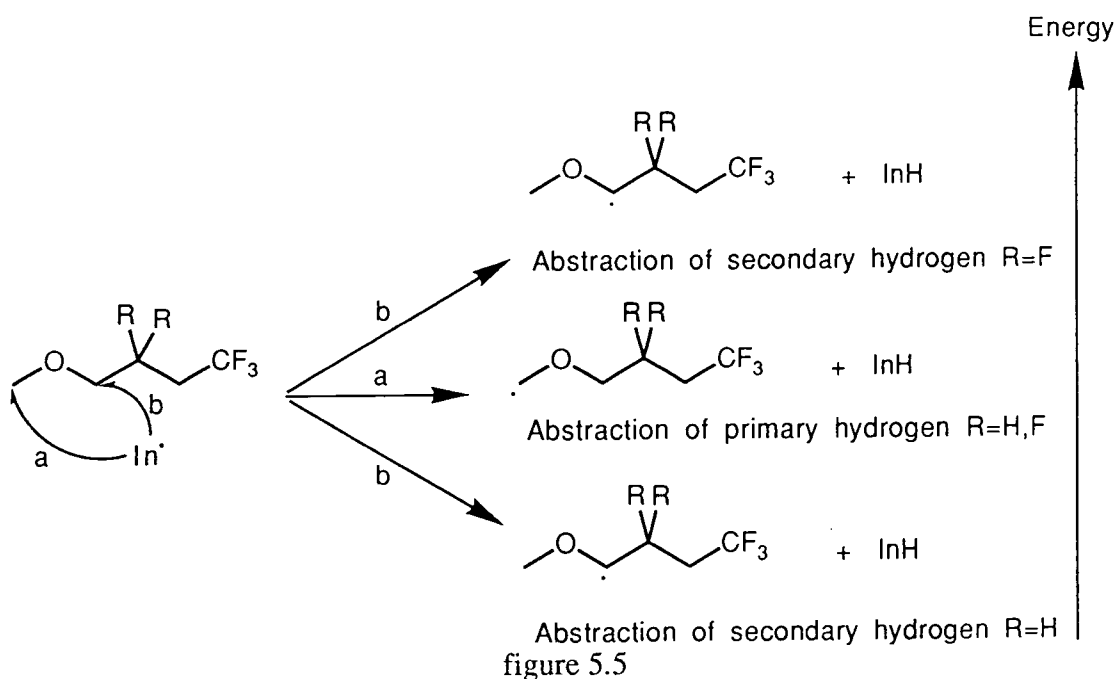

An overall combining of all the points would suggest that (i) and (iii) are the dictating factors, and give the overall reactivity series shown earlier.

V.C.3 Cyclic Fluorinated Ethers

Oxolane, a cyclic ether system, was also studied, due to its similarity to the skeleton of the five membered carbohydrate ring in many nucleosides. The ether was once again reacted with various fluoroalkenes with a view to further functionalisation.

V.C.3.a The Synthesis of Cyclic Fluorinated Ethers

A deficiency of hexafluoropropene is known to react with oxolane under gamma-ray initiation to produce predominantly the mono-adduct,²⁶⁴ this reaction was extended to include the adducts formed using 1,1,3,3,3-pentafluoropropene and chlorotrifluoroethene^{265,266} to give (176), (177) and (178) respectively in yields of 81%, 75% and 41%, some polysubstitution also occurring.

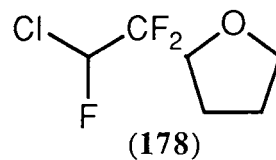
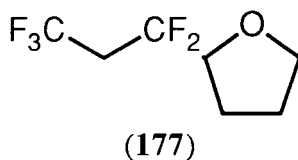
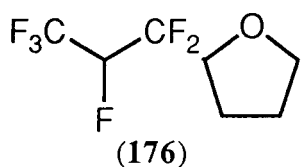

In contrast to dimethyl ether, di-adducts between oxolane and polyfluorinated alkenes are well documented and can be formed under gamma-ray initiation, however, an excess of the fluoroalkene is required to favour polysubstitution. In such a process a capto-dative effect could be envisaged from the inductively electron withdrawing fluoroalkyl group and the donating oxygen atom favouring a radical centre of the type (179).²⁶⁷

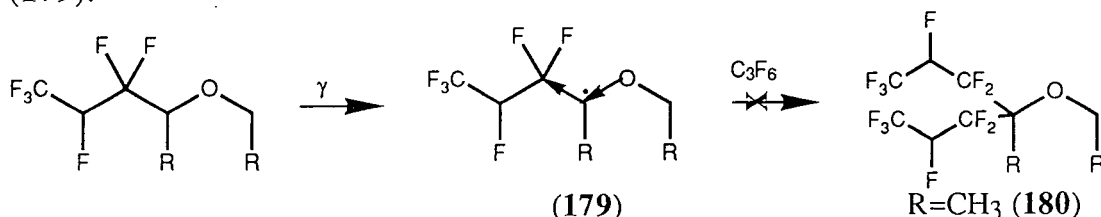

Chambers *et al.*²³⁵ demonstrated that the capto-dative effect did not operate, and rather than enhancing reactivity, the polyfluoroalkyl group deactivates the sites next to oxygen. If disubstitution does occur the di-adduct is formed *via* an intramolecular [1,5]-hydrogen extraction mechanism (scheme 5.5) to give a 2,5-disubstitution pattern in oxolane (181) and in diethyl ether *bis*-(2,2,3,4,4,4-hexafluoro-1-methylbutyl)ether (182) not ethyl-4-(1,1,1,2,3,3,5,5,6,7,7,7-dodecafluoro-4-methylheptyl) ether (180).

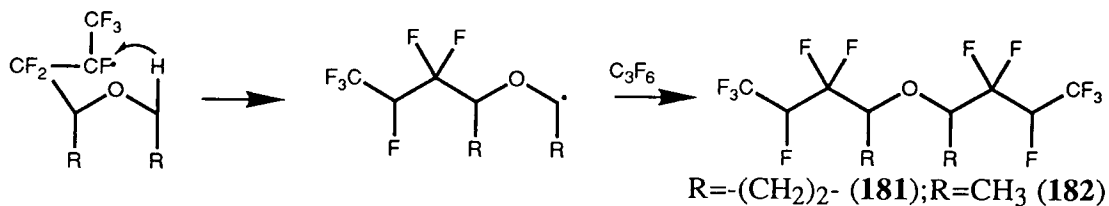

scheme 5.5

Examination of the ^{19}F NMR spectrum of the mono-adduct (**177**) from the reaction of 1,1,3,3,3-pentafluoropropene with oxolane showed not only resonances for (**177**), but also for a di-adduct (**183**). The di-adduct was not isolated because the ratio of (**177**) to (**183**) was approximately 60:1, and was only observable by gas chromatography and ^{19}F NMR spectra (figure 5.6).

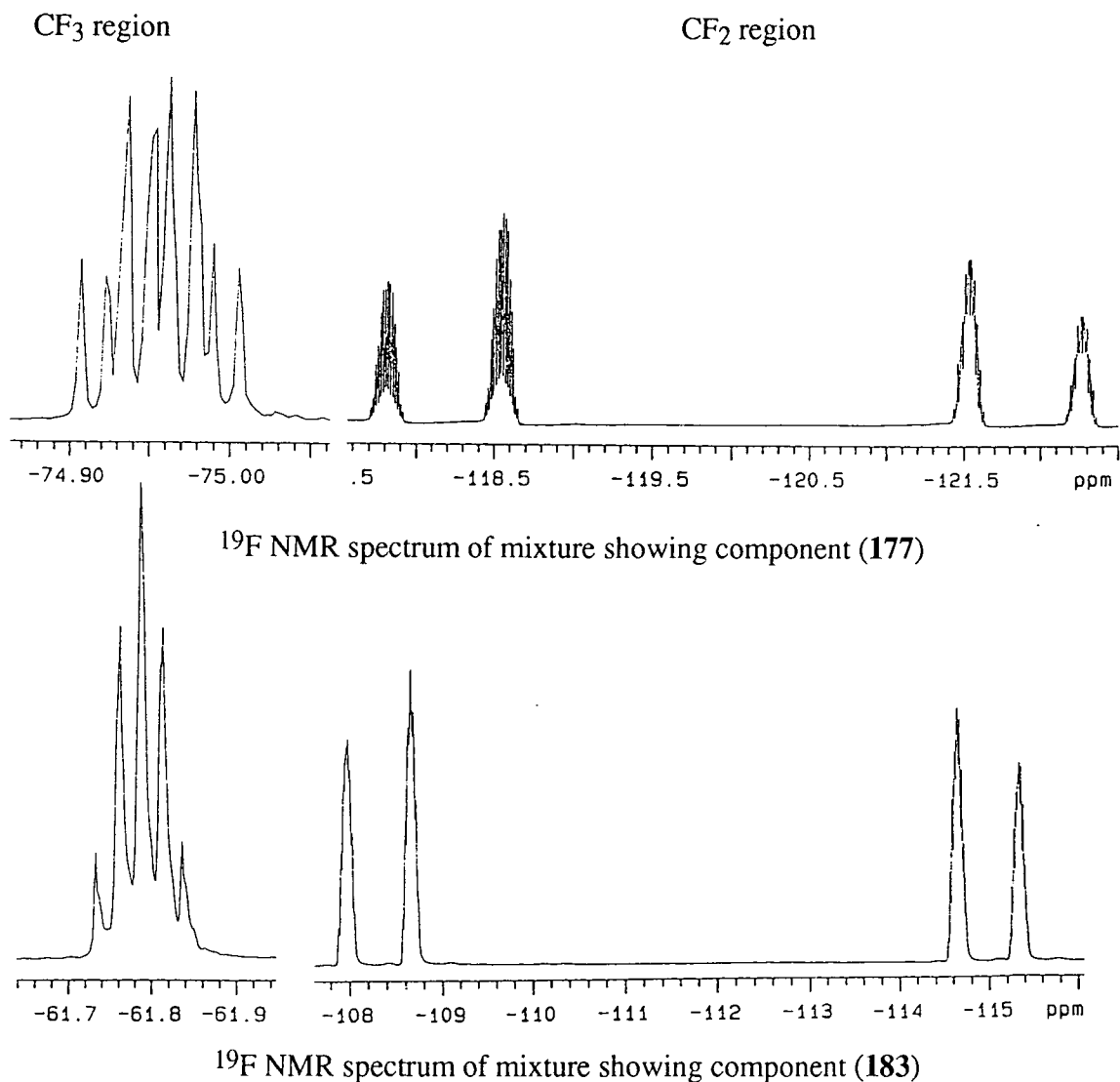

figure 5.6

However, by comparison of the ^{19}F NMR resonances and splitting patterns (table 5.2) for the di-adduct of hexafluoropropene (HFP) and oxolane (**181**) with that of (**183**) it was clear that a further molecule of 1,1,3,3,3-pentafluoropropene (PFP) had not added to the 5-position of oxolane.

	CF ₃		CF ₂	
	HFP [†]	PFP	HFP [†]	PFP
mono-adduct	-74.19	-74.96	-120.10	-118.13
			-124.26	-121.88
di-adduct	-74.27	-61.784	-119.74	-108.25
			-124.64	-115.00

Comparison of pentafluoropropyl and hexafluoropropyl mono- and di-adducts
table 5.2

Further substitution of 2-monosubstituted oxolanes, *e.g.* (176), to the 2,5-disubstituted adducts, *e.g.* (181), gives rise to only a minor perturbation in the trifluoromethyl and difluoromethylene fluorine resonances, due to the element of symmetry possessed by the molecule. The di-adduct of 1,1,3,3,3-pentafluoropropene and oxolane (183) shows a large deviation from the mono-adduct trifluoromethyl and difluoromethylene fluorine resonances. Indeed, the trifluoromethylene region of the ¹⁹F NMR spectrum showed two non-equivalent trifluoromethyl units, and one trifluoromethyl group possessed a splitting pattern indicative of coupling to just one adjacent proton rather than two. This leads to the assignment of a structure where the other pentafluoropropyl unit is at the 2-position of the fluoroalkene (scheme 5.6) *i.e.* 2-[1,1,3,3,5,5,5-heptafluoro-2-(trifluoromethyl)pentyl]oxolane (183).

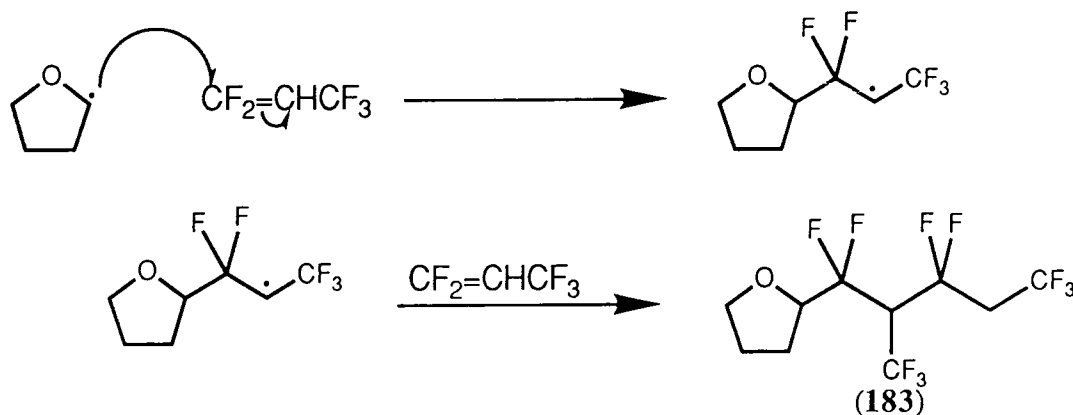

scheme 5.6

The orientation of the free radical addition in (176)-(178) is due to the combination of steric, electronic and stabilisation effects described earlier, thus the difluoromethylene group is attached to the carbon alpha to oxygen. 1,1,3,3,3-Pentafluoropropene lacks a fluorine atom at the 2 position which results in a reduction in stabilisation for the radical centre generated, as compared to the other fluoroolefins, therefore, some homopolymerisation can occur *cf.* 1,1,1-trifluoropropene.²⁶² The low yield of (183) can be explained by steric and electronic constraints, the presence of the

[†] The 3,3,3,2,1,1-hexafluoropropyl adducts are diastereomeric, hence data is quoted for the major diastereoisomer only.

first polyfluoroalkyl group reducing the nucleophilicity of the newly generated radical centre.

V.C.3.b Stereochemistry of Cyclic Fluorinated Ethers

For compounds 2-(1,1,2,3,3,3-hexafluoropropane)oxolane (**176**) and 2-(2-chloro-1,1,2-trifluoroethyl)oxolane (**178**) two chiral centres exist in the molecule, thus more than one diastereoisomer is observed in the ^1H , ^{19}F and ^{13}C NMR spectra, indeed, Cortieu *et al.*²⁶⁸ have recently assigned the ^1H and ^{19}F spectra of adduct (**176**) using the internuclear double resonance NMR experiment (INDOR) and decoupling techniques, indicating the diastereomeric configuration at the two chiral centres. Thus, it was thought that the structure and assignment of the diastereoisomers of (**178**) could be expedited experimentally given the only difference between (**176**) and (**178**) is the replacement of the trifluoromethyl group by the chloro group, simplifying spectral analysis.

It would be expected given the presence of two chiral centres, that four stereoisomeric products would be formed (figure 5.7), of these two are merely enantiomers of the others *i.e.* (**178a**) with (**178d**) and (**178b**) with (**178c**), thus only two possible diastereoisomers can be distinguished by NMR. Table 5.3 indicates the assignment of shifts and coupling constants for the two diastereoisomers based on data from Cortieu²⁶⁸ and Joel²⁵⁴ for the structurally similar molecule (**176**).

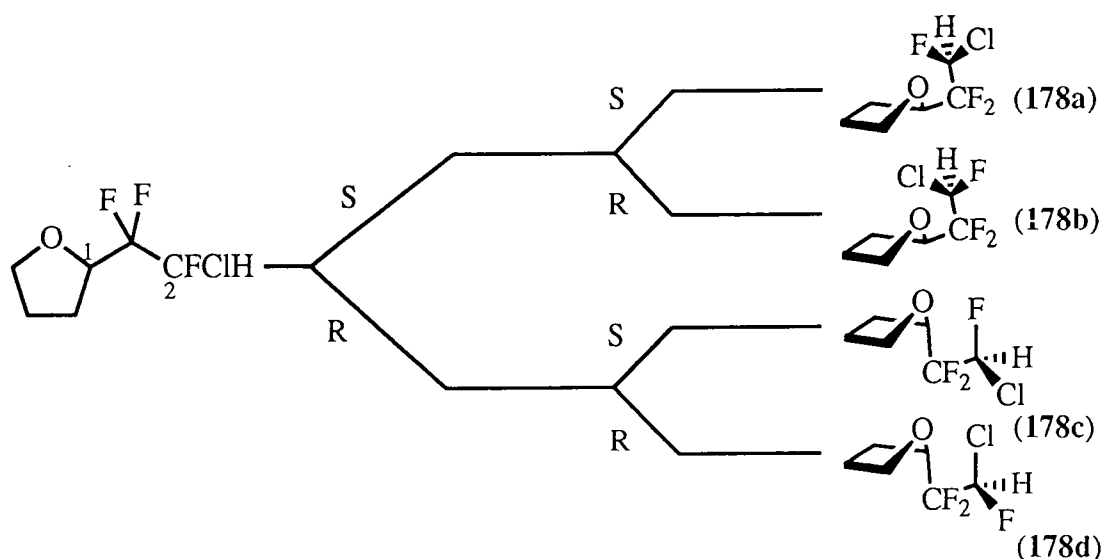
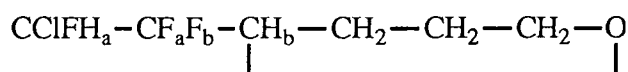

figure 5.7



		H _a	F _a	F _b	H _b	δ
F	SS/RR	48.9	14.1	14.1	-	-160.697
	SR/RS	47.4	9.8	15.1	3.0	-152.787
H _a	SS/RR	-	12.8	12.8	3.6	6.335
	SR/RS	-	14.4	14.4	1.6	6.383
F _a	SS/RR	-	-	255.5	19.6	-128.202
	SR/RS	-	-	264.2	22.2	-127.458
F _b	SS/RR	-	-	-	12.4	-126.072
	SR/RS	-	-	-	3.4	-126.399
H _b	SS/RR	-	-	-	-	4.368
	SR/RS	-	-	-	-	4.331

¹⁹F, ¹H NMR assignments for the diastereoisomers of (178)
table 5.3

The ratio of the diastereoisomers in (178) is 55:45 (*RS/SR:RR/SS*), *cf.* 53:47 (*RS/SR:RR/SS*) in (176).²⁵⁴ The ratio is not 50:50 by virtue of a neighbouring group interaction induced by the first chiral centre generated in the furanyl ring, hydrogen atom abstraction by the polyfluoroalkyl group occurring with a slight preference on the planar face most remote from the ring.

The adduct (177) exists as two indistinguishable enantiomers, therefore no stereochemical assignment could be determined based on the NMR data, due to the use of a non-chiral solvent.

V.D Halogenation of Fluorinated Ethers

V.D.1 Introduction

To carry out further reactions on the fluorinated ethers it becomes necessary to functionalise them by direct halogenation using bromine or chlorine to give an α -haloether.²⁶⁹ These reactive intermediates can be readily reacted with various nucleophiles *e.g.* the use of 2-methoxyethoxymethyl chloride as an alcohol protection group.²⁷⁰

The mechanism for halogenation is *via* a free radical process (scheme 5.7); which results in an α -haloether due to the oxygen heteroatom, which stabilises an adjacent radical site *via* the mesomeric effect.^{236,269} However, the regioselectivity of substitution must be controlled.

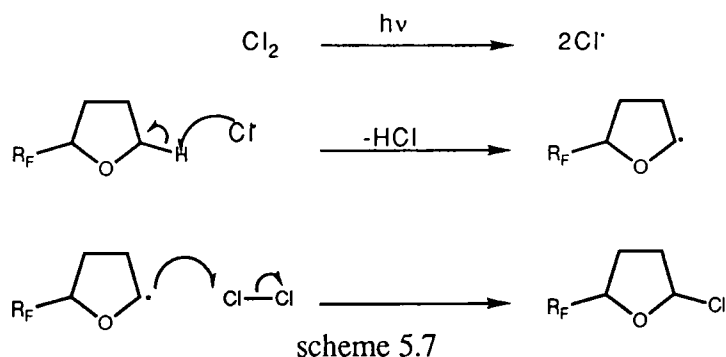

V.D.2 Regioselectivity of Halogenation

The favourable stabilisation of a radical centre by oxygen dictates that the halogen atom initially abstracts a proton adjacent to oxygen, however, two such positions exist.

The Hammond Postulate states that for a single reaction step the geometry of the transition state for that step resembles the side to which it is closer to in free energy. Thus two extreme transition states could be envisaged for proton abstraction by a halogen (figure 5.8):

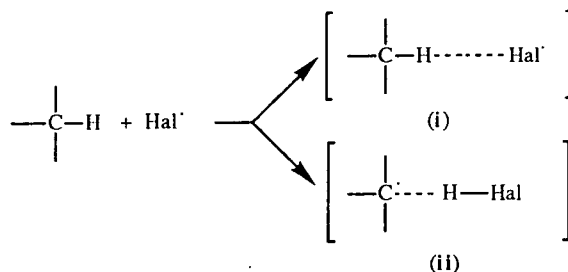

figure 5.8

transition state (i) - The early transition step would be favoured by an initial state of relatively high energy and a final state of low energy *i.e.* a relatively energetic or unstable halogen radical in the initial state, and a relatively strong H-halide bond in the final state;

transition state (ii) - The late transition state would be favoured by a final state of relatively higher energy than the initial state *i.e.* a lower energy halogen radical in the initial state, and a relatively weak H-halide bond in the final state.

However, these are not the only two effects, the repulsion between the initial radical $\text{Hal}\cdot$ and reactant and the newly generated carbon radical and H-Hal must also be considered.

Thus for chlorination, following the Hammond Postulate, the reactive nature of a chlorine radical means the initial state is of high energy and the hydrogen chlorine bond is quite strong (432kJmol^{-1}) which lowers the energy of the final state, pointing to an early transition state (i). In transition state (i) the repulsion between the chlorine atom (no dipole) and the reactant will be negligible in the initial state, however, for the final state hydrogen chloride has a high dipole so any electron withdrawing or donating groups on the carbon radical will have a marked effect, thus, leaving chlorination dominated by polar effects.

Contrast bromination, a relatively less reactive radical and weaker bond dissociation energy for hydrogen bromide (366kJmol^{-1}) indicate a late transition state (ii). The dipole moment of hydrogen bromide is relatively small so polar effects are negligible, therefore, the stability of the developing radical would be the most important factor in influencing the regioselectivity, with hydrogen atom abstraction at what would become the most stabilised carbon centre.

This was borne out experimentally, Chambers *et al.*²⁶⁹ found that when methoxy-2,2,3,4,4,4-hexafluorobutane (**173**) was treated with bromine in carbon disulphide the predominant product was methoxy-1-bromo-2,2,3,4,4,4-hexafluorobutane (**184**), together with a small quantity of dehydrodimers (scheme 5.8), *i.e.* bromination gave the product favoured by a late transition state, the radical formed at the more stable secondary site rather than the primary carbon site.

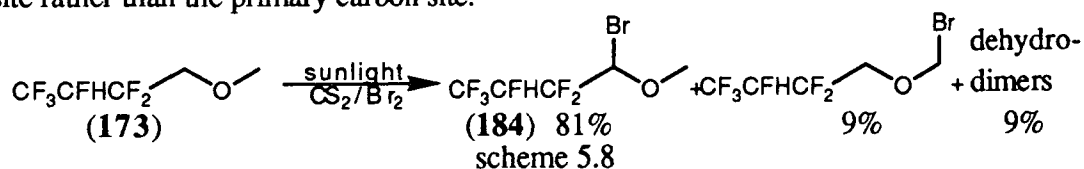

Chlorination was more solvent dependant; polyhalogenation predominated if no solvent was present, and the major products were as a result of halogenation on the methyl group on the opposite side of the ether oxygen.

However, the yield of the mono-adduct 1-chloromethoxy-2,2,3,4,4,4-hexafluorobutane (**185**) was optimised by the use of carbon disulphide as a solvent, perhaps due to solvent interaction with the chlorine radical inducing selectivity and thus less polychlorinated by-products.²⁷¹ Thus, chlorination gave predominantly 1-chloromethyl-2,2,3,4,4,4-hexafluorobutane (**185**) due to attack at the least electrophilic site, *i.e.* the terminal methyl group, a polar effect and a consequence of an early transition state.

Chlorination of the polyfluoroalkylethers gave the correct regiochemistry to make analogues of (**55**), thus a series of chlorinations were carried out (table 5.4).

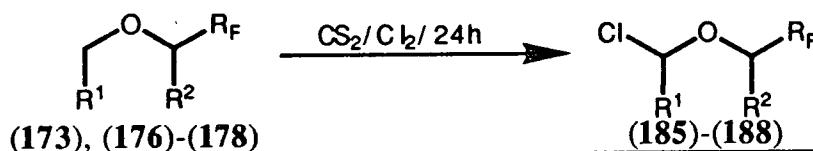

Reactant	R _F	Product	Yield(%)
(173)	CF ₃ CFHCF ₂	R ¹ =H; R ² =H (185)	47
(176)	CF ₃ CFHCF ₂	R ¹ =R ² = -(CH ₂) ₂ - (186)	84 [†]
(177)	CF ₃ CH ₂ CF ₂	R ¹ =R ² = -(CH ₂) ₂ - (187)	52 [†]
(178)	CFClHCF ₂	R ¹ =R ² = -(CH ₂) ₂ - (188)	63 [†]

Chlorination of polyfluoroethers (173)-(178)

table 5.4

[†] Yields are based on ¹H NMR spectra

The α -haloether (**185**) was the only polyhalogenated ether which could be purified, since the α -haloethers (**186**)-(**188**) were, without exception, thermally and hydrolytically unstable entities. The oxolanes (**186**)-(**188**) readily lost hydrogen chloride, *via anti*-elimination, in the presence of base *e.g.* powdered sodium hydroxide. Both stereoisomers could undergo elimination (scheme 5.9), an equatorial chloro group undergoing inversion of the oxygen centre allowing the chloro group to 'flip' into the axial position, the dihedral angle with the adjacent hydrogen atom tending to 180° ideal for *anti*-elimination, to yield the dihydrofuran derivatives. The dihydrofuran derivative was isolated in the case of (**186**) as a clear colourless oil (**189**).

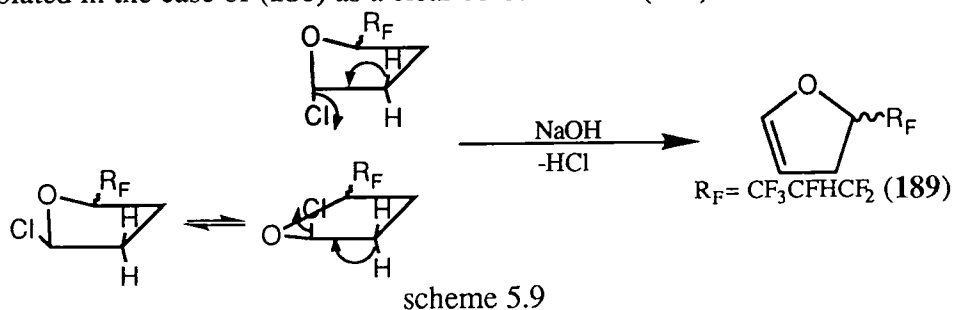

The acyclic α -haloether (**185**) lacked an alpha methylene group, which excluded the possibility of elimination and could be isolated by preparative gas chromatography in a 47% yield.

The yields were unaffected by the nature of the polyfluoroalkyl group, due to the remote position of the polyfluoroalkyl group from the site of chlorine attack. However, the bulky groups may have had an effect in the stereospecificity of the chlorine atom abstraction. This factor could only be ascertained from NMR studies.

V.D.3 Spectrometric Assignment of Polyfluorinated α -Haloethers

The assignment of the ^1H NMR shifts for the products of halogenation, (**186**) to (**188**), was greatly complicated by the introduction of a further chiral centre into the molecules. Indeed (**186**) and (**188**) have eight possible stereoisomers, essentially giving four sets of ^1H ring resonances, each heavily coupled to each other, while for (**187**) with only four stereoisomers two sets of peaks are obtained, thus all have multiple AB systems overlapping in a narrow range. Therefore, only a limited assignment of the chemical shifts could be obtained relating to the stereo- and regio-selectivity of chlorination.

Some evidence exists for a certain amount of stereochemical control in the free radical addition process.²⁶⁰ This has been observed by Joel²⁵⁴ who invoked a steric argument for the approach of an electrophilic radical *trans*- to that of a bulky polyfluoroalkyl group. This process would be expected, therefore, to yield an inversion of the chirality of the new chiral centre with respect to the old one. This is in fact observed in the ^1H NMR spectrum of the α -haloethers (figure 5.9) with resonances for the geminal proton to the chloro group coming at both 6.35ppm (*trans*-) and 6.23ppm

(*cis*-) in (186). A non-selective radical process should in theory give a mixture of the *cis*- and *trans*-isomers (approximately 1:1). However, figure 5.9 shows the ratio between the isomers was greatly in favour of the *trans*-isomer (71:29). Indeed, some form of neighbouring group participation must be taking place, the bulky polyfluoroalkyl group favouring approach of the chlorine molecule from the opposite face.

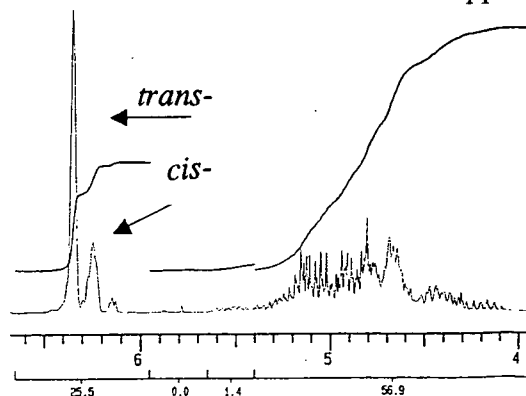

figure 5.9

The ¹H NMR spectra also indicated that the 5 position was not fully chlorinated, however, it could not be determined whether this was due to the formation of 2-chloro-2-polyfluoroalkyloxolanes or merely starting material.

V.E The Coupling of Nucleoside Bases to Polyfluorinated α -Haloethers

V.E.1 Introduction

Previously (Chapter III) the coupling of purine bases by nucleophilic attack at an activated halogenated allylic site was described. However, the displacement of a halogen substituent adjacent to oxygen has been extensively studied, particularly for the introduction of pyrimidine bases.

V.E.2 Methods of Coupling Pyrimidine Bases

Initially, methods to couple pyrimidine bases to chloro- or acetoxy- furanose systems employed heavy metal derivatives,²⁷² *e.g.* silver and mercury salts, however, this was undesirable in biological systems, due to contamination of the nucleosides by these toxic metals and their derivatives. The problem was negated with the advent of the Hilbert-Johnson method.

The original Hilbert-Johnson method²⁷³ required the use of 2,4-dialkoxypyrimidines, and proceeded *via* the formation of a quaternary ammonium salt, followed by subsequent deprotection to liberate the nucleoside. With the advent of the 2,4-substituted silyl derivatives of heterocyclic bases the nucleosides could be obtained directly.²⁷⁴ Further, addition of a Lewis acid catalyst *e.g.* tin (IV) chloride²⁷⁵ or more recently trimethylsilyl triflate,²⁷⁶ had been shown to significantly increase the yield of the

nucleoside product. Thus, the latter methodology was adopted to couple the pyrimidine bases uracil and 5-fluorouracil to the polyfluorinated α -haloethers (**185**)-(188).

V.E.2.a Silylation of Uracil and 5-Fluorouracil

Silylation of both uracil and 5-fluorouracil are a prerequisite of the modified Hilbert-Johnson method. This facile process was carried out in accordance to the literature method,²⁷⁴ *i.e.* excess hexamethyldisilazane (HMDS) in the presence of ammonium sulphate catalyst (scheme 5.8).

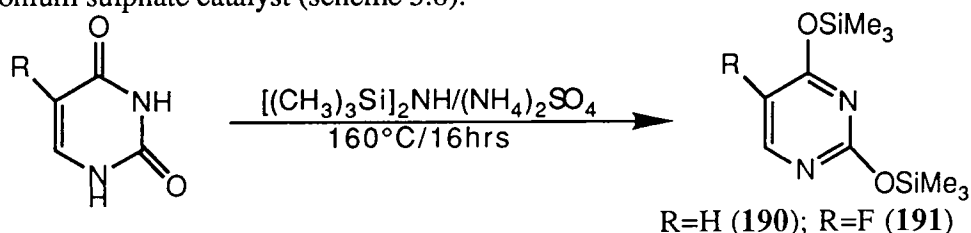

scheme 5.8

The silylated bases 1,3-disilyloxyuracil (**190**) and 5-fluoro-1,3-disilyloxyuracil (**191**), were isolated as oily residues after distillation, *in vacuo*, to remove excess HMDS, and used without further purification or analysis due to their hydrolytic instability.

V.E.2.b Coupling of Silylated Uracil (**190**) and 5-Fluorouracil (**191**) to Polyfluorinated α -Haloethers

Following literature procedures the silylated bases (**190**) and (**191**) were coupled to the α -haloethers (**185**)-(188), utilising a Lewis acid catalyst, either trimethylsilyl triflate^{276,277} or tin (IV) chloride.^{278,279} The products isolated, in all cases, were anomeric mixtures (by ¹H NMR) of the desired pyrimidine substituted polyfluoroethers (scheme 5.9).

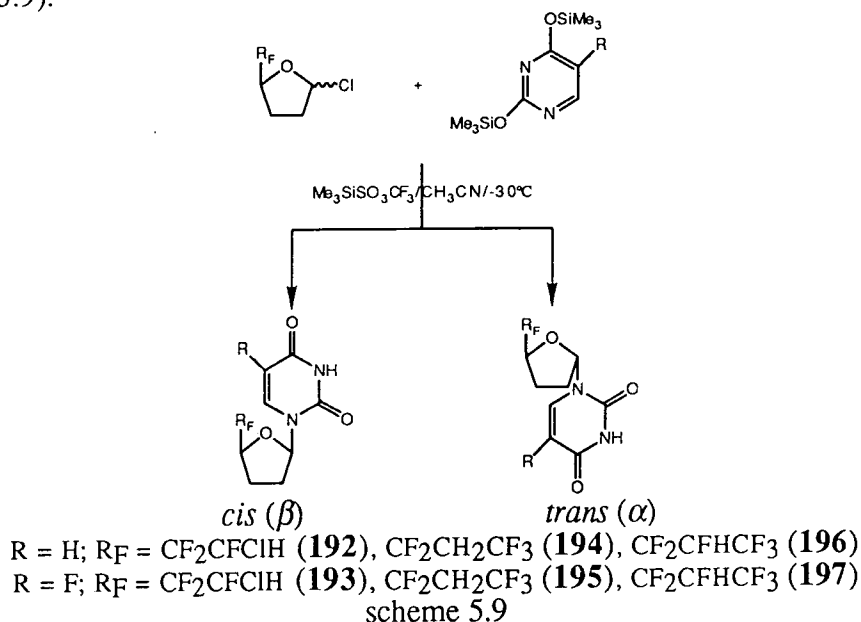

The results are summarised in table 5.6, which illustrate:

- (i) the choice of Lewis acid catalysis does not have a significant effect on either the yield or the anomeric ratio of the products. In the synthesis of (196) the anomeric ratio was 1:1 *via* tin (IV) chloride catalysis, *cf.* 5:7 for trimethylsilyl triflate catalysis;
- (ii) the yields of the 5-fluorouracil derivatives were in general much lower than that of the uracil analogues, due to the reduction of electron density at the N1 position.

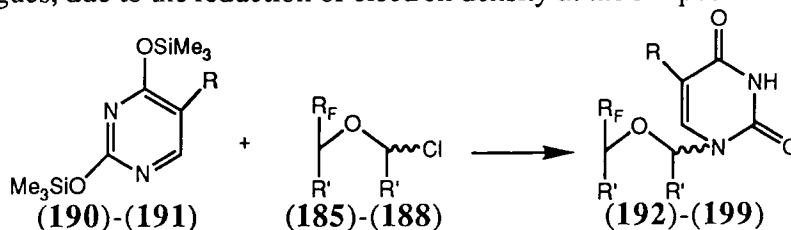

Base	α -Haloether	Product	Yield (%)	Anomeric Ratio
R=H (190)	R _F =CF ₂ CClFH (188) R'=R'=- (CH ₂) ₂ -	(192)	47	2:3
R=F (191)	R _F =CF ₂ CClFH (188) R'=R'=- (CH ₂) ₂ -	(193)	45	1:1
R=H (190)	R _F =CF ₂ CH ₂ CF ₂ (187) R'=R'=- (CH ₂) ₂ -	(194)	52	5:7
R=F (191)	R _F =CF ₂ CH ₂ CF ₂ (187) R'=R'=- (CH ₂) ₂ -	(195)	49	2:3
R=H (190)	R _F =CF ₂ CFHCF ₂ (186) R'=R'=- (CH ₂) ₂ -	(196)	72	5:7
R=H (190)	R _F =CF ₂ CFHCF ₂ (186) R'=R'=- (CH ₂) ₂ -	(196)	68	1:1 ^a
R=F (191)	R _F =CF ₂ CFHCF ₂ (186) R'=R'=- (CH ₂) ₂ -	(197)	63	2:3
R=H (190)	R _F =CF ₂ CFHCF ₂ (185) R'=R'=H	(198)	33	-
R=F (191)	R _F =CF ₂ CFHCF ₂ (185) R'=R'=H	(199)	25	-

yield and the ratio of the anomeric products (192)-(199)

table 5.6

V.E.2.c Stereochemistry of the Pyrimidine Substituted Polyfluorinated α -Haloethers

The assignment of the stereochemical outcome of the coupling reactions was determined by interpretation of ¹H NMR spectra, particularly the region from 5.5ppm to 7.0ppm where the H1' resonance can be found. The H1' chemical shift giving an

^a Tin (IV) chloride was used as the Lewis acid catalyst

indication of whether the substituted pyrimidine ring is *cis*- or *trans*- to the polyfluoroalkyl group.

The acyclic pyrimidine substituted derivatives (198) and (199) have no chiral centre, thus ^1H NMR showed only one product, which could be assigned as uradylmethoxy-2,2,3,4,4,4-hexafluorobutane and 5-fluorouradylmethoxy-2,2,3,4,4,4-hexafluorobutane respectively.

However, in the cyclic oxolane systems a number of stereoisomers are possible by the very nature of the substitution mechanism (scheme 5.10). Indeed, the mechanism indicates that although the α -haloethers (186), (187) and (188) were a mixture of *cis*- and *trans*- isomers, ultimately, no isomeric separation was required, as racemisation of the chloromethyl position occurred *via* generation of an intermediate carbocation.

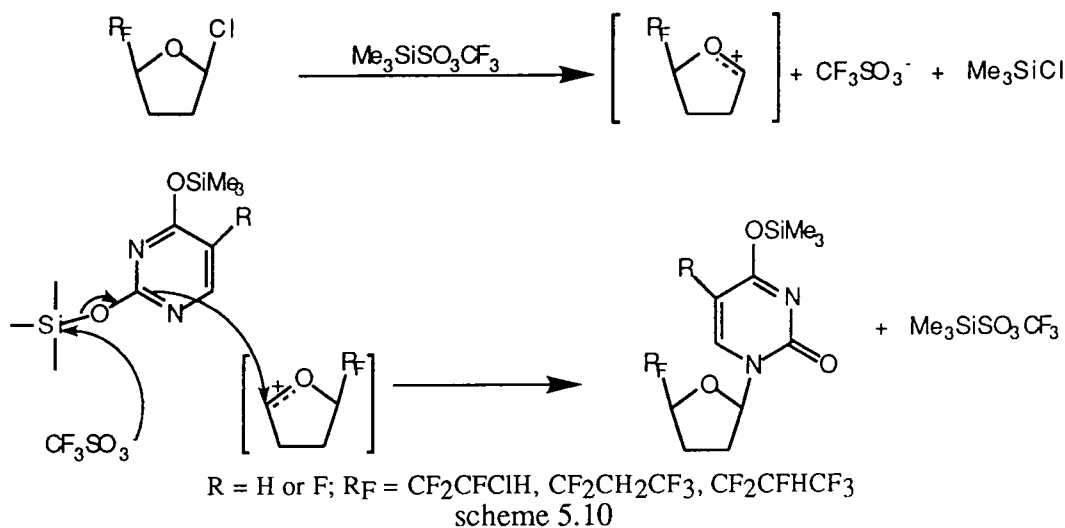

The highly unstable intermediate carbocation could be subsequently attacked from either face of the molecule, hence *cis*- and *trans*- isomers are possible, *i.e.* β - and α -anomers respectively. Thus, with the addition of the chiral centre in the polyfluoroalkyl group of (192),(193),(196) and (197) four diastereoisomers exist, all of which are observed by NMR (figure 5.10).

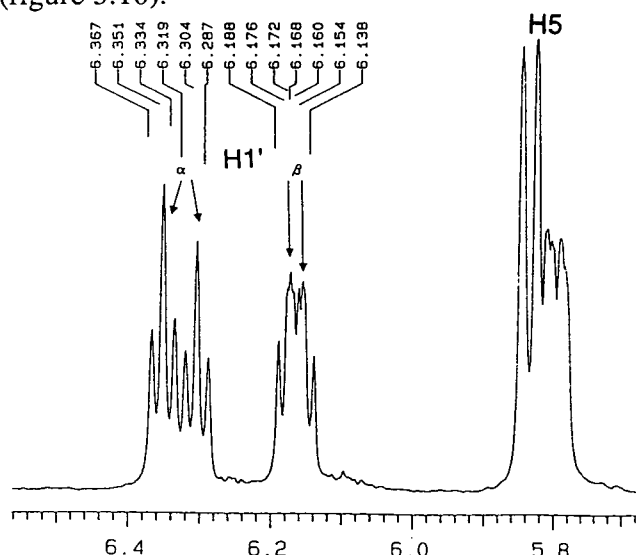

the four diastereoisomeric resonances for the H1' atom in 2-(3,3,3,2,1,1-hexafluoropropyl)-5-uradyloxolane(196).

figure 5.10

The resonances for the *cis*- and *trans*-isomers and, subsequently, the anomeric ratios quoted in table 5.6 were assigned empirically based on the NMR data of closely related compounds,²⁸⁰⁻²⁸² thus Pedersen²⁸³ obtained the structurally similar nucleoside 2',3'-dideoxy-6-*N,N*-dimethyladenosine as the α -isomer (**200b**) with a resonance for the C2' hydrogens at 2.53ppm, and a C1' hydrogen resonance at 6.32ppm compared to the β -isomer (**200a**) which had chemical shifts of 2.75ppm for C2' and 6.03ppm for the hydrogen at C1' in *d*-chloroform, this can be compared directly to the ¹H NMR spectrum of 2-(3,3,3,1,1-pentafluoropropyl)-5-uridyloxolane (**194**) where resonances occur at 2.13ppm, 2.58ppm and 6.14ppm, assigned as the β -isomer and at 2.01ppm, 2.42ppm and 6.30ppm, the α -isomer. Finally, the anomeric ratios were calculated by comparison of the integration of the ¹H resonances of the hydrogen at C1' (figure 5.10).

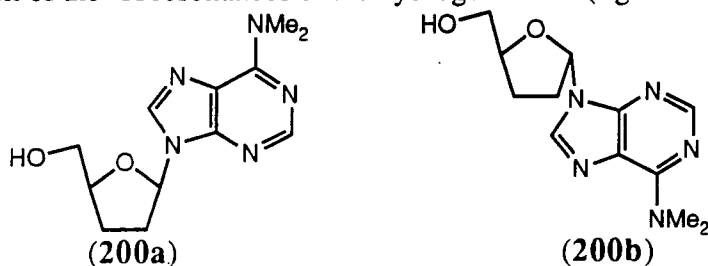

Although distinguishable by NMR techniques the diastereoisomers could not be separated by thin layer or medium pressure chromatography on silica, thus pure samples of the anomers could not be obtained. However, separation was observed by analytical high pressure liquid chromatography, running on a normal phase silica column (figure 5.11).

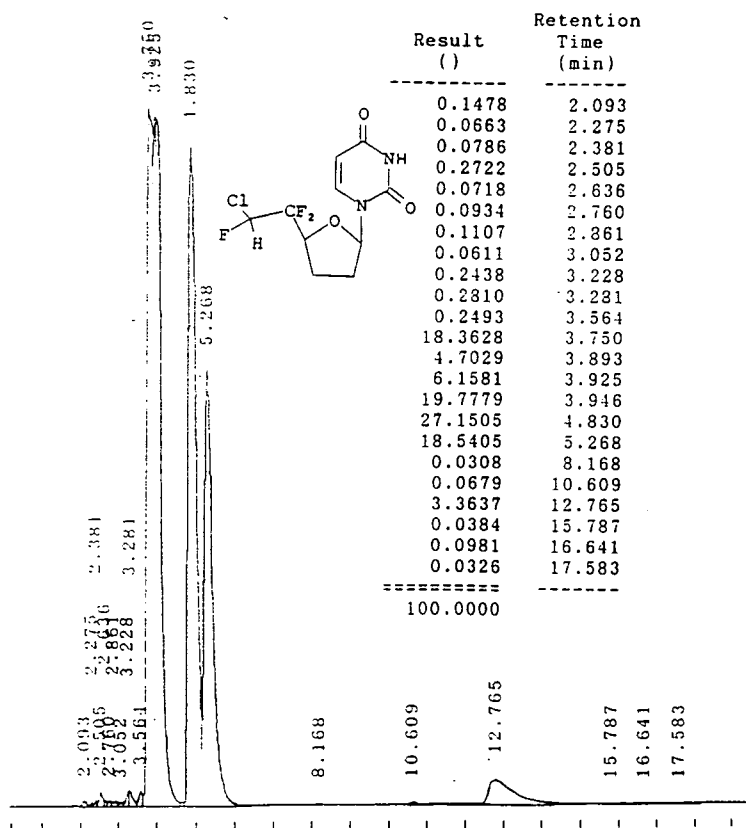

figure 5.11

Full assignment of the remaining ring hydrogens was made by use of COSY spectra, thus from figure 5.12, the ^1H COSY spectrum of 2-(1-chloro-1,2,2-trifluoroethyl)-5-uridyloxolane (**192**) it can be seen:

(i) $\text{H1}'(\alpha\text{-isomer})$ at 6.30ppm is coupled to two hydrogen atoms at shifts of 2.04ppm and 2.45ppm, these must be $\text{H2}'(\alpha\text{-isomer})$, one of which is *cis*- to $\text{H1}'(\alpha\text{-isomer})$;

(ii) the hydrogen atom at 2.04ppm *i.e.* $\text{H2}'(\alpha\text{-isomer})$ is coupled to a large multiplet at 2.35ppm which must be the resonance of the two $\text{H3}'(\alpha\text{-isomer})$;

(iii) they in turn are strongly coupled to a resonance at 4.52ppm, which by a process of elimination must be $\text{H4}'(\alpha\text{-isomer})$;

(iv) a similar treatment for the remaining resonances gives the $\text{H1}'(\beta\text{-isomer})$ at 6.15ppm, coupled to $\text{H2}'(\beta\text{-isomer})$ 2.14ppm, which is in turn coupled to the other $\text{H2}'(\beta\text{-isomer})$ 2.60ppm and two hydrogen atoms resonating at 2.39ppm $\text{H3}'(\beta\text{-isomer})$ and finally at 4.80ppm $\text{H4}'(\beta\text{-isomer})$

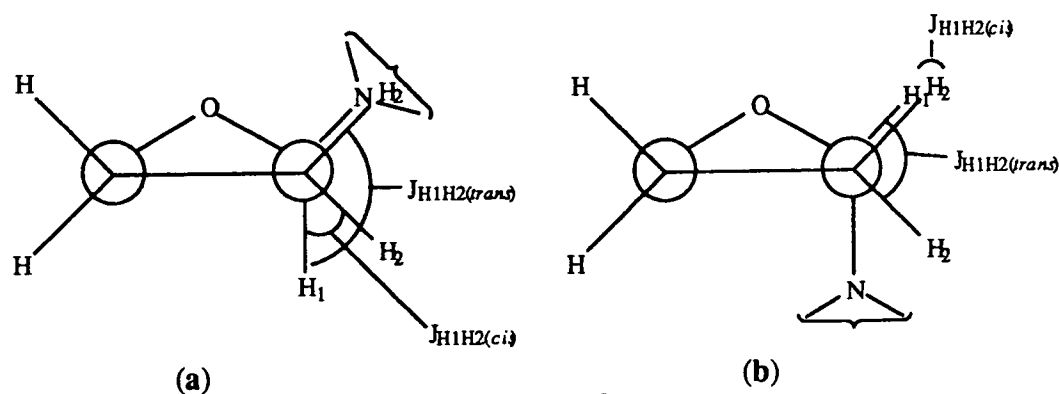
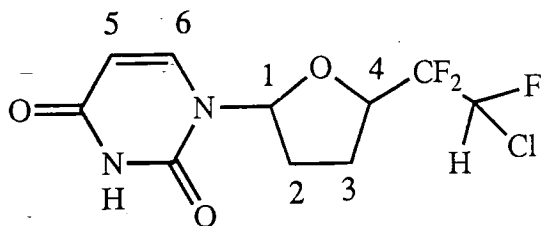

figure 5.13

The fact the ^1H COSY spectrum shows the coupling of $\text{H1}'$ in one instance to both $\text{H2}'$ atoms, while for the other case only one coupling to the lower field $\text{H2}'$ atom can easily be explained in terms of the Karplus equation. Thus, in figure 5.13 for structure (a) the Karplus equation would lead us to expect an approximately equal coupling to both the $\text{H2}'$ atoms from $\text{H1}'$, while in (b) there will be a large coupling between $\text{H1}'$ and $\text{H2}'(\textit{cis})$ and no coupling to $\text{H2}'(\textit{trans})$. However, this information does not give any indication whether the resonances correspond to an α - or β -anomer, because only the relative disposition of one side of the molecule has been deduced. The COSY spectrum reveals no detailed coupling between $\text{H3}'$ and $\text{H4}'$, which would have enabled a similar analysis of the stereochemistry of the polyfluoroalkyl group.

The 2D COSY spectra also showed that no N3 substitution had taken place in the nucleosides (**192**)-(199). N3 substitution manifesting itself in a $^3\text{J}_{\text{NHCH}}$ coupling of approximately 7Hz,²⁷⁹ however, no coupling between the N1 hydrogen atom and the vicinal C6 hydrogen atom could be observed (figure 5.12).

The anomeric ratio for the pyrimidine nucleosides varied in all the systems, however, the substitution did not favour the sterically less demanding, 'unnatural' *trans*-isomers.

2D ^1H COSY NMR spectrum

(192)

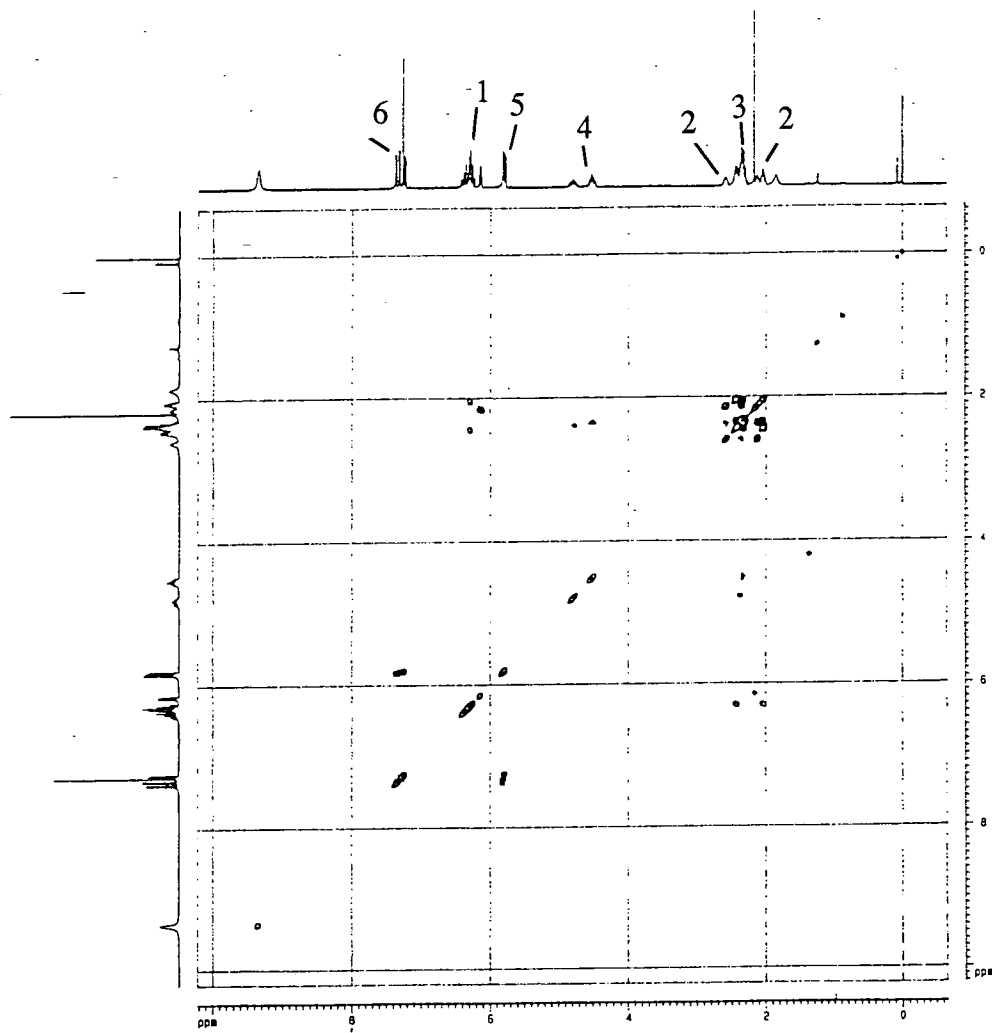
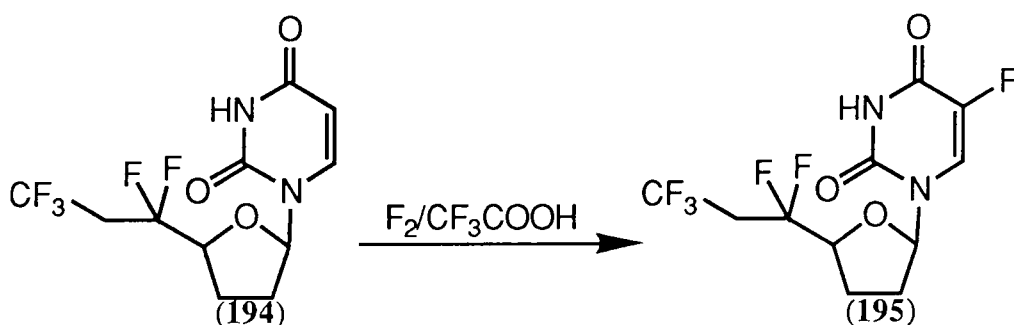

figure 5.12

V.F The Synthesis of 2-(5-Fluorouracyl)-5-(1,1,1,3,3-pentafluoropropyl)oxolane (195) by Direct Fluorination

The synthesis of 5-fluorouracil and its derivatives *via* direct fluorination is well documented, and therefore it was decided to attempt the fluorination of the uracil derivative (**194**) to yield 2-(5-fluorouracyl)-5-(1,1,1,3,3-pentafluoropropyl)oxolane (**195**) (scheme 5.11).



scheme 5.11

The initial experimental procedure used to fluorinate (**194**), was to bubble a 10% mixture of fluorine in nitrogen into a stirred solution of 2-uracyl-5-(1,1,1,3,3-pentafluoropropyl)oxolane (**194**) in trifluoroacetic acid. Trifluoroacetic acid was used rather than water or acetic acid to effect the transformation to (**195**) because of three factors:

- (i) work by Rozen^{284,285} and Misaki²⁸⁶ had shown that polar solvents increased the conversion of a substrate to the fluorinated derivatives significantly, due to an increased electrophilicity of the fluorine, simultaneously scavenging any non-selective fluorine radicals, which lead to the degradation of the substrate;
- (ii) the use of trifluoroacetic acid obviates problems which could arise from side reactions, since fluorine can react with the solvent rather than the substrate; trifluoroacetic acid has a high degree of resistance to fluorination *cf.* acetic acid;
- (iii) the nucleoside (**194**) was readily soluble in trifluoroacetic acid, and showed no hydrolysis of the glycosidic linkage, by NMR, after two days in the medium.

After aqueous work up of the crude reaction mixture the ¹⁹F NMR showed no 1-(5-fluorouracyl)-4-(1,1,1,3,3-pentafluoropropyl)oxolane (**195**), however, Visser *et al.*²⁸⁷ showed in an elegant mechanistic study, utilising ¹⁸F₂, that the mechanism for the fluorination of uracil proceeded as shown in scheme 5.12.

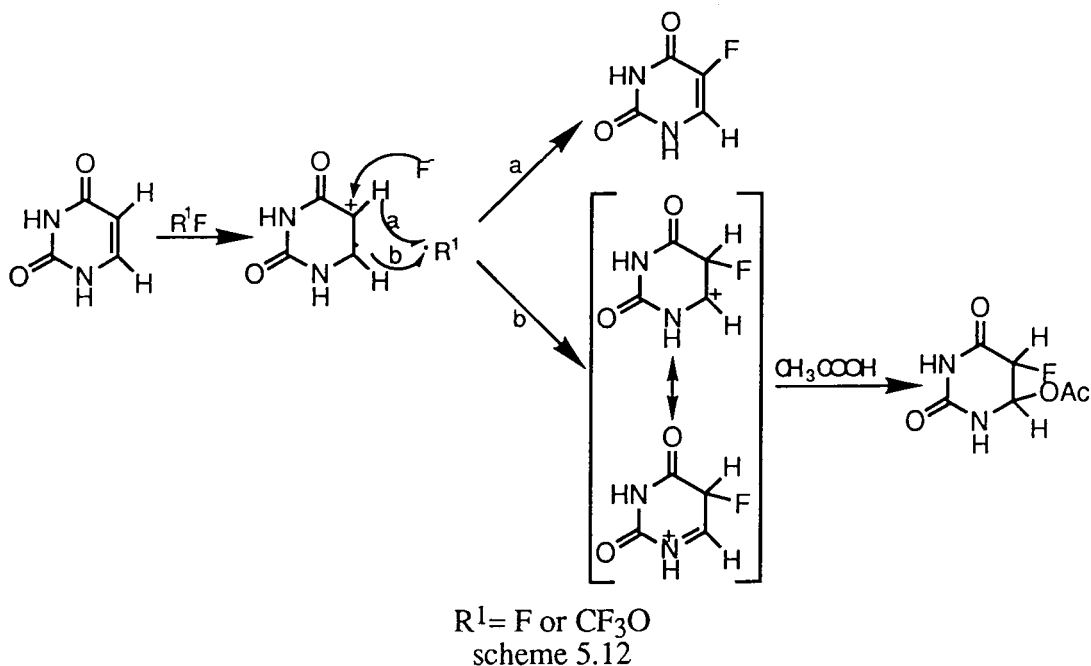

To give predominantly the acetoxy compound (**201**), unless heat is applied, *via* path b.

Thus after purification of the crude mixture by column chromatography (eluent ethyl acetate) two products were isolated and found to be 2-(5-fluoro-6-hydroxyuradyl)-5-(1,1,1,3,3-pentafluoropropyl)oxolane (**202**) and unexpectedly uracil (**203**). Compound (**202**), a white solid, was present as the major product obtained in a yield of 80%, while (**203**) was isolated in 8% yield. The formation of (**202**) could be rationalised by the mechanism outlined above, the intermediate 2-(5-fluoro-6-trifluoroacetoxyuradyl)-5-(1,1,1,3,3-pentafluoropropyl)oxolane (**204**) initially produced, undergoing subsequent hydrolysis upon work-up to give 2-(5-fluoro-6-hydroxyuradyl)-5-(1,1,1,3,3-pentafluoropropyl)oxolane (**202**), since trifluoroacetate is an excellent leaving group (scheme 5.13).

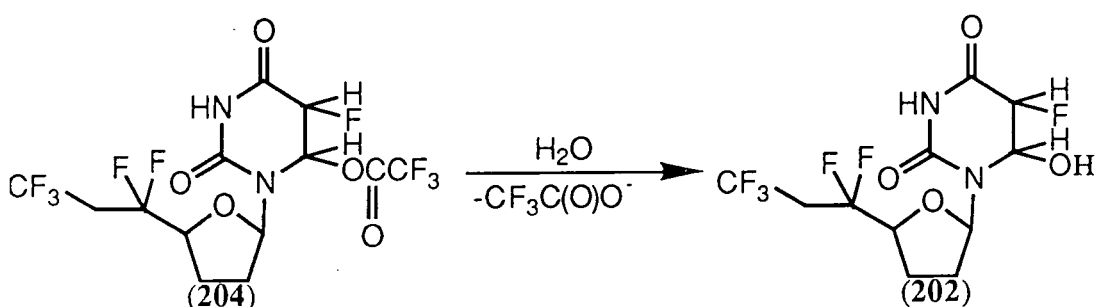

scheme 5.13

The formation of (**203**) is much harder to envisage and may have resulted from acid cleavage of the glycosidic linkage,²²³ liberating the free polyfluoroalkyloxolane, which probably was not seen in the crude reaction mix due to its volatility (scheme 5.14).

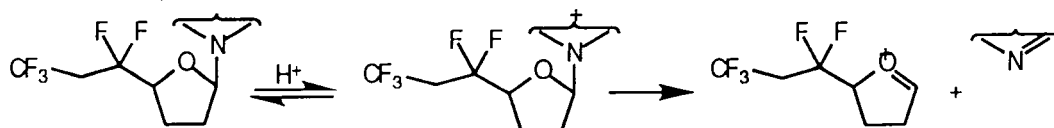

scheme 5.14

Dehydration of (202) by heating under vacuum yielded 2-(5-fluorouradyl)-5-(1,1,1,3,3-pentafluoropropyl)oxolane (195) in near quantitative yield, 94% (scheme 5.15).

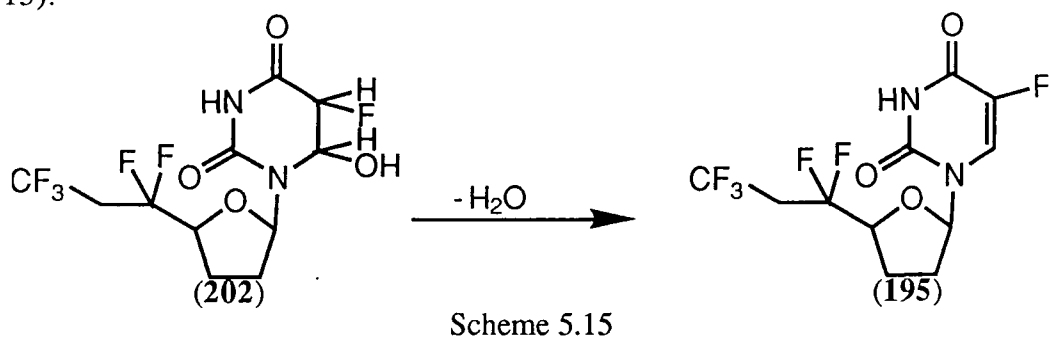

V.G Methods of Coupling Purine Bases

The conditions used to couple the purine class of bases *via* the precursors 6-chloropurine (144) and 2-amino-6-chloropurine (148) were as outlined in chapter III, and the results are summarised in table 5.7.

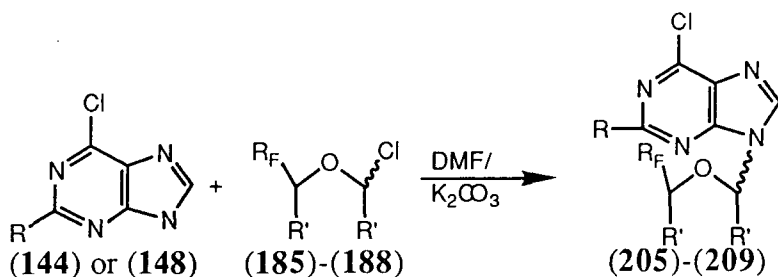

Base	α -haloether	product	Yield (%)	Anomeric ratio
R=NH ₂ (148)	R _F =CF ₂ CFHCF ₂ (185) R'=R'=H	(205)	7	-
R=H (144)	R _F =CF ₂ CFHCF ₂ (186) R'=R'=- (CH ₂) ₂ -	(206)	23	3:1
R=NH ₂ (148)	R _F =CF ₂ CFHCF ₂ (186) R'=R'=- (CH ₂) ₂ -	(207)	11	- [†]
R=H (144)	R _F =CF ₂ CH ₂ CF ₂ (187) R'=R'=- (CH ₂) ₂ -	(208)	17	8:1
R=H (144)	R _F =CF ₂ CClFH (188) R'=R'=- (CH ₂) ₂ -	(209)	31	- [†]

Yields of purinyl substituted polyfluoroethers
table 5.7

The yields for the purine class of heterocycles was much lower than that obtained for the pyrimidine bases. This fact could be rationalised by the greater steric bulk of the purine derivatives and the difference in the methodology used to couple the bases. Higher yields could, perhaps, have been realised by utilisation of the lithium salts of the

[†] Ratio could not be determined by ¹H NMR.

purine bases, the production of the purinyl anion, a stronger nucleophile increasing both rate and yield of the desired products.¹¹⁷

As for the pyrimidine base substituted products (206)-(209) a mixture of stereoisomers are possible, thus it became important to assign the stereochemical outcome of the reaction both in terms of *cis*- and *trans*- isomerism in the oxolane ring and N7 versus N9 substitution in the purine ring.

V.G.1 Stereochemistry of the Purine Substituted Polyfluorinated α -Haloethers

The assignment of the stereochemical outcome of the coupling reactions was determined by interpretation of NMR and UV spectra. For the acyclic purine substituted derivative 2-amino-6-chloropurinylmethoxy-1,1,2,3,3,3-hexafluorobutane (205) the ¹H NMR spectrum showed only one stereoisomer, *cf.* uracylmethoxy-2,2,3,4,4,4-hexafluorobutane (198) and 5-fluorouracyl-methoxy-2,2,3,4,4,4-hexafluorobutane (199).

All the oxolane derivatives showed *cis*- and *trans*- isomerism, but displayed a greater degree of stereospecificity than the equivalent pyrimidine coupled products. The fact that one isomer was favoured, to such a large extent, can only be explained by the greater steric bulk of the purinyl bases.

The purine bases can, in principle, couple through either the N7 or N9 nitrogen atoms in the imidazole ring, this is particularly true for guanine derivatives. The UV spectra of the purinyl derivatives were, therefore, measured to determine whether N7 or N9 substitution had occurred. N9 substituted 6-chloropurinyl derivatives and 2-amino-6-chloropurinyl derivatives display strong absorption in the 266nm²⁰⁰ and 310nm¹¹⁵ regions respectively, thus the results summarised in table 5.8 show that exclusive N9 substitution has taken place; the reasons for such substitution has been discussed previously (section III.D.2.b and section III.D.2.e).

(205)	(206)	(207)	(208)	(209)
248, 304nm	262nm	248,304nm	262nm	262nm

UV absorption of purinyl nucleoside precursors
table 5.8

V.G.2 Deprotection of Purine Substituted Polyfluorinated α -Haloethers

V.G.2.a Deprotection of 2-Amino-6-chloropurinyldimethoxy-1,1,2,3,3,3-hexafluorobutane (205) and 2-(2-Amino-6-chloropurinyldimethoxy-1,1,2,3,3,3-hexafluoropropyl)oxolane (207)

The methodology for the deprotection of the 2-amino-6-chloropurinyldimethoxy functionality to the guanyl functionality is a facile process and involved hydrolysis with dilute mineral acid (table 5.9)(see section III.D.2.f).

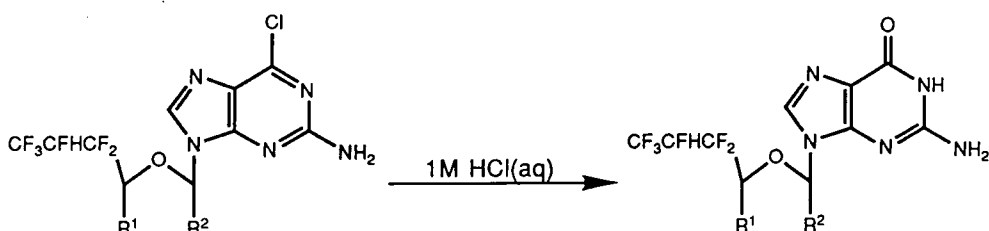

2-amino-6-chloropurine derivative	R ₁ /R ₂	Product	Yield (%)
(205)	R ¹ =R ² =H	(210)	73
(207)	R ¹ =R ² = -(CH ₂) ₂ -	(211)	85

yields of purine nucleosides
table 5.9

Thus the reaction proceeded to yield the guanyl derivatives in high yield as white solids.

V.G.2.b Deprotection of 2-(6-Chloropurinyldimethoxy)-5-polyfluoroalkyloxolane

The deprotection of the 6-chloropurinyldimethoxy functionality in the polyfluoroether derivatives (205),(206),(208) and (209) was accomplished utilising standard literature conditions (table 5.10)¹⁴¹. No problems were encountered with this method, *cf.* the (diethoxyphosphinyl)difluoromethylene derivative (145)(section III.D.2.c).

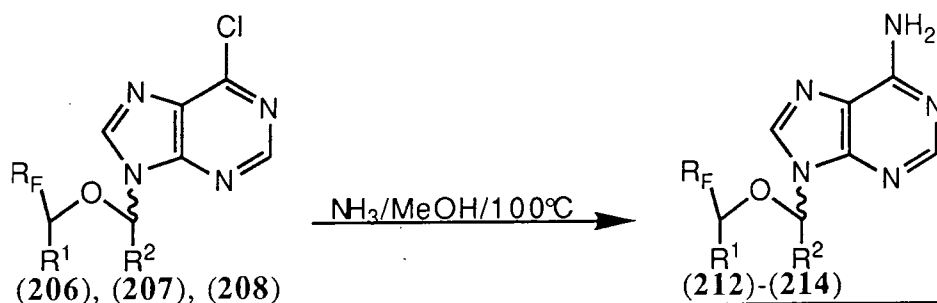

6-Chloropurine derivative	R _F	R ₁ /R ₂	Product	Yield (%)
(206)	CF ₂ CFHCF ₃	R ¹ =R ² = -(CH ₂) ₂ -	(212)	85
(208)	CF ₂ CH ₂ CF ₃	R ¹ =R ² = -(CH ₂) ₂ -	(213)	80
(209)	CF ₂ CFCIH	R ¹ =R ² = -(CH ₂) ₂ -	(214)	91

yields of purine nucleosides
table 5.10

Thus, excellent yields were obtained for all the derivatives and the products were subsequently purified by normal phase silica gel chromatography (eluent ethyl acetate).

V.H Biological Test Data on Purine and Pyrimidine Substituted Polyfluorinated α -Haloethers

The compounds (192)-(199) and (212) are currently under test at SmithKline Beecham Laboratories (Great Burgh) for any *in vitro* antiviral activity.

V.I Conclusion

Polyfluorinated α -haloethers were successfully reacted with soft nitrogen nucleophiles *i.e.* substituted purines and pyrimidines. The yields, in all cases, were greater for the pyrimidine class of compounds, probably due to the pyrimidines being less sterically demanding, as well as the different coupling mechanism used. It was interesting to note that an attempt to couple a primary amine (ethylamine) resulted in no reaction with the polyfluorinated α -haloether (184). Given the higher basicity of ethylamine over the purines and pyrimidines used and the lack of any significant steric hindrance this result is somewhat anomalous.

It was observed that 1-chloromethoxy-2,2,3,4,4,4-hexafluorobutane (185) gave the lowest yield of all the polyfluorinated α -haloethers utilised, the other derivatives gave approximately the same yield irrespective of the polyfluoroalkyl group, this reactivity may be due to the greater stabilisation of the carbocation in the cyclic oxolane systems due to the positive inductive effect of the adjacent ring methylene units.

EXPERIMENTAL SECTION

INSTRUMENTATION

Gas liquid Chromatography (g.c.) analysis was carried out on a Hewlett Packard 5890A gas chromatograph fitted with a 25m cross-linked methyl silicone capillary column. Preparative g.c. was performed on a Varian Aerograph Model 920 (catharometer detector) gas chromatograph.

Fractional distillation of products was carried out using a Fischer Spahlrohr MMS 255 small concentric tube apparatus. Boiling points were recorded during distillation. Melting points were carried out at atmospheric pressure and are uncorrected.

Carbon, hydrogen and nitrogen elemental analyses were obtained using a Perkin-Elmer 240 Elemental Analyser or a Carlo Erba 1106 Elemental Analyser.

Ultraviolet spectra were recorded on a Perkin-Elmer Lambda 2 or a Pye-Unicam PU 8720 UV/Vis spectrometer.

Infra Red spectra were recorded on either a Perkin-Elmer 457 or 577 Grating Spectrophotometer using conventional techniques.

Proton NMR spectra were recorded on a Hitachi Perkin-Elmer R-24B (60MHz), a Brüker AC250 (250MHz), and a Varian VXR400S (400MHz) NMR spectrometer.

Fluorine NMR spectra were recorded on a Varian EM3601 (56.45MHz), a Brüker AC250 (235MHz) and a Varian VXR400S (376MHz) NMR spectrometer.

Carbon NMR spectra were recorded on a Brüker AC250 (65MHz) and a Varian VXR400S (100.6MHz) NMR spectrometer.

Phosphorus NMR spectra were recorded on a Brüker AC250 (101MHz) NMR spectrometer.

Mass Spectra of solid samples were recorded on VG 7070E spectrometer. G.c. mass spectra were recorded on the VG 7070E spectrometer linked to a Hewlett Packard 5790A gas chromatograph fitted with a 25m cross-linked methyl silicone capillary column.

REAGENTS

In general chemicals were used as received from suppliers (Aldrich, Lancaster, Fluka, Fluorochem and Sigma) and solvents were dried by literature procedures.

CHAPTER VI**EXPERIMENTAL TO CHAPTER II****VI.A The Chemistry of (Diethoxyphosphinyl)difluoromethylene Zinc Bromide (94)****VI.A.1 Preparation of (Diethoxyphosphinyl)bromodifluoromethane (94)**

A flask was charged with triethylphosphite (73.75g, 442mmol) in anhydrous ethoxyethane (300ml), cooled to 0°C and dibromodifluoromethane (100g, 478mmol) added dropwise. The reactants were left to warm up to room temperature then refluxed at 40°C for 24h. The solvent was removed under reduced pressure and the product purified by vacuum distillation to leave a colourless liquid (diethoxyphosphinyl)bromodifluoromethane (**94**)(107.65g, 90%); b.p 105°C/16.1 mmHg; (Found: C, 23.0; H, 3.95. Calc. for C₅H₁₀BrF₂O₃P: C, 22.5; H, 3.8%); IR spectrum recorded; δ_{H} (250MHz, CDCl₃, TMS) 1.45 (6H, t, $^3J_{\text{HH}}=7.2\text{Hz}$, CH₃), 4.33 (4H, dq, $^3J_{\text{HH}}=7.2\text{Hz}$, CH₂O); δ_{F} (237MHz, CDCl₃, CFCl₃) -60.63 (2F, d, $^2J_{\text{PF}}=93.1\text{Hz}$, PCF₂Br); m/z (CI+) 286 (MH⁺+NH₃, 98%), 284 (MH⁺+NH₃, 100%); as compared to literature data (δ_{F} -61.9ppm).¹⁴³

VI.A.2 Preparation of (Diethoxyphosphinyl)bromodifluoromethylene Zinc Bromide (95)

(Diethoxyphosphinyl)bromodifluoromethane (**94**)(3.05g, 11.4mmol) was added dropwise to a stirred suspension of dry acid washed zinc dust (0.74g, 11.3mmol) in anhydrous monoglyme (6ml) at room temperature. After 12h the solution was filtered through a Schlenk-filter (No3) to remove any unreacted zinc. The colourless clear solution was then used without further purification. (Diethoxyphosphinyl)difluoromethylene zinc bromide (**95**)(conversion 100% by ¹⁹F NMR); δ_{F} (237MHz, monoglyme, CFCl₃) -125.9 (2F, d, $^2J_{\text{PF}}=92.9\text{Hz}$, PCF₂Zn); as compared to the literature value (δ_{F} -126.1ppm).¹⁴⁷

The preparation was repeated many times, as the material was required. The reaction could be scaled up to 250mmol without any problems. In all the following reactions (diethoxyphosphinyl)bromodifluoromethylene zinc bromide will be referred to as Burton's reagent.

VI.A.3 Reactions of Benzyl Bromide

VI.A.3.a Reaction of Benzyl Bromide and Burton's Reagent (95)

A flask was charged with a solution of Burton's reagent (**95**)(21.2mmol) in monoglyme, benzyl bromide (3.62g, 21.3mmol) and copper (I) bromide (0.05g, 0.3mmol), under a nitrogen atmosphere. The solution was heated at 40°C for 12h then filtered to remove any copper (I) bromide and washed with 2M hydrochloric acid (2x20ml) followed by saturated sodium hydrogen carbonate until neutral. At this point a white precipitate was collected insoluble in both the ether and the water layer. The organic washings were then dried, magnesium sulphate, filtered and solvent removed under reduced pressure to yield a mixture of products. ¹⁹F NMR spectra allowed identification of the products as (*Z*)-1,2-difluoroethenebisphosphonate (53%, by NMR); δ_F (237MHz, CDCl₃, CFCl₃) -128.42 (2F, ddd, ²J_{PF}=81.9, ³J_{PF}=18.1, ³J_{FF}=15.0Hz, PCF=PCF); as compared to literature (-128.3ppm),¹⁵⁷ and (diethoxyphosphinyl)-difluoromethane (20%, by NMR); δ_F (237MHz, CDCl₃, CFCl₃) -136.11 (2F, dd, ²J_{PF}=91.6, ²J_{FH}=49.2Hz, PCF₂H) compared to -136.01ppm for an authentic sample (section VI.B.1).

The white solid was sublimed, and analyses showed it to be bibenzyl (**100**)(42%, 0.79g); m.p. 49-50°C;²⁸⁸ IR spectra recorded; δ_H (250MHz, CDCl₃, TMS) 2.33 (4H, s, CH₂ CH₂), 6.53 (10H, s, Ph CH₂); m/z (EI+) 182 (M⁺, 100%), 91 (M⁺-PhCH₂).

VI.A.2.b Reaction of Benzyl Bromide and Copper (I) Bromide

A flask was charged with benzyl bromide (2.00g, 12mmol) and copper (I) bromide (0.06g, 0.4mmol) and stirred at 40°C for 12h. The crude reaction mixture was then tested by TLC (silica) against authentic bibenzyl (eluent 40-60 petroleum ether), no bibenzyl was observed.

VI.A.2.c Reaction of Benzyl Bromide and Zinc

A flask was charged with benzyl bromide (2.00g, 12mmol) and acid washed zinc powder (0.78g, 12mmol) and stirred at 40°C for 12h. The crude reaction mixture was then tested by TLC (silica) against authentic bibenzyl (eluent 40-60 petroleum ether), no bibenzyl was observed.

VI.A.4 Reactions of Allylic Bromides and Burton's Reagent (95)

VI.A.4.a Preparation of 3-Bromocyclopentene (103)¹⁵⁸

A flask was charged with cyclopentene (6.82g, 10mmol), *N*-bromosuccinimide (17.80g, 10mmol) and a spatula tip of azobisisobutyronitrile (AIBN) in dry carbon tetrachloride (100ml) was heated until succinimide was observed floating on the top of the solution, after which the heat source was removed the exothermic reaction left until no *N*-bromosuccinimide was observed. The reaction mixture was filtered through a celite plug and the solvent removed under reduced pressure. The crude product was purified by vacuum distillation to give a colourless liquid 3-bromocyclopentene (**103**)(5.26g, 35.8%); b.p. 40-55°C/45mmHg; δ_{H} (250MHz, CDCl₃, TMS) 2.495-2.360 (3H, m, ring CH₂), (4H, dq, CH₂O); m/z (EI+) 66 (M⁺-HBr, 100%).

VI.A.4.b Preparation of 3-Bromocyclohexene (104)¹⁵⁸

A mixture of cyclohexene (8.20g, 10mmol), *N*-bromosuccinimide (17.80g, 10mmol) and a spatula tip of AIBN initiator in dry carbon tetrachloride (100ml) was heated until succinimide was observed floating on the top of the solution, after which the heat source was removed the exothermic reaction left until no *N*-bromosuccinimide was observed. The reaction mixture was filtered through a celite plug and the solvent removed under reduced pressure. The crude product was purified by vacuum distillation to give a colourless liquid 3-bromocyclohexene (**104**)(8.1g, 50.34%); b.p. 81-85°C/34mmHg; δ_{H} (400MHz, CDCl₃, TMS) 1.690 (1H, m, equatorial-ring H), 1.895-2.096 (2H, m, equatorial ring CH₂), 2.140-2.300 (3H, m, axial ring CH₂) 4.849 (1H, m, CHBr), 5.797-5.934 (2H, m, CH=); m/z (EI+) 162 (MH⁺, 8%), 160 (MH⁺, 8%), 80 (M⁺-HBr, 100%).

VI.A.4.c Preparation of 3-Bromocycloheptene (105)¹⁵⁸

A mixture of cycloheptene, 92%, (24.72g, 23.7mmol), *N*-bromosuccinimide (37.91g, 21.3mol) and a spatula tip of AIBN initiator in dry carbon tetrachloride (100ml) was heated until succinimide was observed floating on the top of the solution, after which the heat source was removed the exothermic reaction left until no *N*-bromosuccinimide was observed. The reaction mixture was filtered through a celite plug and the solvent removed under reduced pressure. The crude product was purified by vacuum distillation to give a colourless liquid 3-bromocycloheptene (**105**)(14.97g, 40.1%); b.p. 56°C/4mmHg; δ_{H} (270MHz, CDCl₃, TMS) 1.477-2.362 (8H, m, ring CH₂), 4.908 (1H, td, CHBr), 5.690-5.954 (2H, m, CH=); m/z (EI+) 176 (M⁺, 1.6%), 174 (M⁺, 1.8%), 95 (M⁺-HBr, 100%).

VI.A.4.d Reaction of 3-Bromocyclopentene (103) and Burton's Reagent (95) at -15°C

A flask was charged with copper (I) bromide (0.05g, 0.3mmol) and 3-bromocyclopentene (**103**)(1.01g, 6.8mmol) in anhydrous monoglyme (10ml), cooled to -15°C (ice/salt) and Burton's reagent (**95**) added dropwise (6.8mmol). The solution was stirred for 12h and then warmed to room temperature, filtered through a celite pad and washed with 10% HCl(aq) (2x20ml), then saturated sodium hydrogen carbonate until neutral. The product was then extracted with ethoxyethane (3x50ml) and dried (magnesium sulphate), filtered and isolated after removal of solvent by reduced pressure. The crude product was then run down a silica gel column (ethoxyethane/30-40°C petroleum ether 1:1) to yield 3-[(diethoxyphosphinyl)difluoromethyl]cyclopentene (**106**)(0.09g, 5%); [Found: C, 47.0; H, 6.7.(MH⁺ 255) C₁₀H₁₇F₂O₃P requires C, 47.25; H, 6.7%]; b.p. 145°C/4mmHg; NMR spectrum 1; IR spectrum 1; mass spectrum 1.

VI.A.4.e Reaction of 3-Bromocyclopentene (103) and Burton's Reagent (95) at 20°C

The reaction was repeated as above at room temperature with Burton's reagent (**95**)(7.4mmol), copper (I) bromide (0.05g, 0.3mmol) and 3-bromocyclopentene (1.09g, 7.4mmol), to give a blue black polymeric material which contained no fluorine.

VI.A.4.f Reaction of 3-Bromocyclopentene (103) and Burton's Reagent (95) at -69°C

The reaction was repeated as above except the reaction flask cooled and maintained at -69°C for 10h (acetone/dry ice) with Burton's reagent (**95**)(50.1mmol), copper (I) bromide (0.05g, 0.3mmol) and 3-bromocyclopentene (2.32g, 15.8mmol), to give 3-[(diethoxyphosphinyl)difluoromethyl]cyclopentene (**106**)(0.35g, 8.9%). Data as section VI.A.4.d.

VI.A.4.g Reaction of 3-Bromocyclohexene (104) and Burton's Reagent (95) at -69°C

To a cooled (acetone/dry ice) mixture of copper (I) bromide (0.05g, 0.3mmol) and 3-bromocyclohexene (**104**)(1.61g, 10.0mmol) in anhydrous monoglyme (10ml), was added dropwise Burton's reagent (**94**)(9.3mmol). The solution was stirred for 12h and then warmed to room temperature, filtered through a celite plug, washed with 10% HCl(aq) (2x20ml), and saturated sodium hydrogen carbonate until neutral. The product

was then extracted with ethoxyethane (3x50ml), dried (magnesium sulphate), filtered and the solvent removed under reduced pressure. The crude product was then Kugelrohr distilled to give a colourless oil 3-[(diethoxyphosphinyl)difluoromethyl]cyclohexene (107)(1.83g, 71%); [Found: C, 49.25; H, 6.8.(M⁺ 268) C₁₁H₁₉F₂O₃P requires C, 49.2; H, 7.1%]; b.p. 125°C/0.3mmHg; NMR spectrum 2; IR spectrum 2; mass spectrum 2.

VI.A.4.h Reaction of 3-Bromocyclohexene (104) and Burton's Reagent (95) at 86°C

The reaction was repeated as above subsequently heating the solution to reflux for a further 4h, with copper (I) bromide (0.05g, 0.3mmol) and 3-bromocyclohexene (104)(16.226g, 101mmol) in anhydrous monoglyme (30ml), to which Burton's reagent (94)(101mmol) was added, to give 3-[(diethoxyphosphinyl)difluoromethyl]cyclohexene (107)(16.838g, 65%). Data as above.

VI.A.4.i Reaction of 3-Bromocycloheptene (105) and Burton's Reagent (95) at -69°C

To a cooled (cardice/acetone) mixture of copper (I) bromide (0.05g, 0.3mmol) and 3-bromocycloheptene (105)(14.969g, 85mmol) in anhydrous monoglyme (20ml), was added Burton's reagent (95)(85mmol). The solution was stirred for 12h and then warmed to room temperature, filtered through a celite plug, washed with 10% hydrochloric acid (2x20ml), and saturated sodium hydrogen carbonate until neutral. The product was then extracted with ethoxyethane (3x50ml), dried with magnesium sulphate, filtered and the solvent under reduced pressure. The crude product was then Kugelrohr distilled to give a colourless oil 3-[(diethoxyphosphinyl)difluoromethyl]cycloheptene (108)(11.215g, 51.3%); [Found: C, 49.9; H, 7.2.(MH⁺ 283) C₁₂H₂₁F₂O₃P requires C, 51.0; H, 7.5%]; b.p. 125°C/0.06mmHg; NMR spectrum 3; IR spectrum 3; mass spectrum 3.

VI.A.4.j Reaction of 3-Bromocycloheptene (105) and Burton's Reagent (95) at 86°C

The reaction was repeated as above subsequently heating the solution to reflux for a further 4h, with copper (I) bromide (0.05g, 0.3mmol) and 3-bromocycloheptene (105)(1.61g, 10.0mmol) in anhydrous monoglyme (10ml), to which Burton's reagent (94)(9.3mmol) was added, to give 3-[(diethoxyphosphinyl)difluoromethyl]cycloheptene (108) (1.83g, 65%). Data as above.

VI.A.5 Attempted Palladium (0) Catalysed Reactions of Burton's Reagent with Allylic Acetates and Phenyl Allyl Ethers

VI.A.5.a Preparation of Cyclohex-3-ene carboxylic acid¹⁶⁴

A steel autoclave (450ml capacity) was charged with acrylic acid (14.25g, 200mmol) and butadiene (13.71g, 250mmol). The autoclave was heated, in a rocking furnace, at 160°C for 30mins. Excess butadiene was recovered (2.82g, 50mmol) and the product purified by vacuum distillation, to give a clear colourless liquid cyclohex-3-ene carboxylic acid (22.8g, 100%); (found: C 66.7; H 8.2. Calc. for C₇H₁₀O₂: C 67.0; H 8.0%); b.p. 150°C/23mmHg; δ_{H} (60MHz, CDCl₃, TMS) 2.13 (7H, m, ring CH₂), 5.63 (2H, m, CH=), 11.23 (1H, s, CO₂H).

VI.A.5.b The Synthesis of 1-Iodo-6-oxa-bicyclo[3.2.1]octan-5-one¹⁶³

A mixture of cyclohex-3-ene carboxylic acid (22.1g, 180mmol), sodium hydrogen carbonate (14.75g, 180mmol), and water (250ml) were mechanically stirred. After cessation of effervescence, potassium iodide (52.92g, 320mmol) and iodine (44.7g, 200mmol) were added and the contents left stirring for 5h. The reaction mixture was filtered, and the filtrate extracted with ethoxyethane (3x100ml), and dried with magnesium sulphate. The solvent was removed under reduced pressure and the resulting solid combined with the filtrand. The iodolactone was then recrystallised from chloroform. The reaction yielded pale yellow crystals of 1-iodo-6-oxa-bicyclo[3.2.1]octan-5-one (37.76g, 83%); δ_{H} (250MHz, CDCl₃, TMS) 1.827-2.452ppm (5H, m, ring CH₂), 2.680 (1H, m, CHC=O), 2.797 (1H, d, ³J_{HH}=12.3Hz, CHOCH_eH_aCHC=O), 4.512 (1H, t, ³J_{HH}=4.8Hz, CHI), 4.832 (1H, t, ³J_{HH}=5.0Hz, CHO); m/z (CI+) 270 (MH⁺+17, 100%).

VI.A.5.c The Synthesis of 6-Oxa-bicyclo[3.2.1]octen-5-one (113) A¹⁶⁵

A suspension of 1-Iodo-6-oxa-bicyclo[3.2.1]octan-5-one (16.99g, 70mmol) and silver acetate (14.78g, 90mmol) in anhydrous DMSO (120ml) was heated at 130°C for 3h under nitrogen, with mechanical stirring. The reaction mixture was then diluted with chloroform (500ml) and filtered through a celite pad to remove silver. The filtrate was washed with water, brine, dried with magnesium sulphate and filtered. After removal of the solvent under reduced pressure, the residual oil was distilled *in vacuo* to give a clear colourless oil 6-oxa-bicyclo[3.2.1]octen-5-one (**113**)(6.18g, 74%);

b.p. 110°C/20mmHg; δ_{H} (250MHz, CDCl₃, TMS) 2.105 (1H, d, ³J_{HH}=10.4Hz, CHOCH_eH_aCHC=O), 2.453-2.540 (3H, m, ring CH₂), 2.918 (1H, m, CHC=O),

4.772 (1H, t, $^3J_{\text{HH}}=4.9\text{Hz}$, CHO), 5.825-6.270 (2H, m, CH=); m/z (CI+) 142 (MH⁺+17, 100%), 125 (MH⁺, 5%).

VI.A.5.d The Synthesis of 6-Oxa-bicyclo[3.2.1]octen-5-one (113) B¹⁶⁵

A mixture of 1-Iodo-6-oxa-bicyclo[3.2.1]octan-5-one (2.52g, 10mmol), and 1,5-diaza[5.4.0]undecene (1.57g, 10mmol) in anhydrous benzene (300ml) was maintained at reflux for 6h, under nitrogen. The solution was then washed with water, dried with magnesium sulphate and filtered. The oil obtained by evaporation of solvent under reduced pressure was distilled *in vacuo* to afford 6-Oxa-bicyclo[3.2.1]octen-5-one (**113**)(0.31g, 25%), data as above.

VI.A.5.e The Synthesis of Cis-3-Hydroxy-5-carbomethoxy-1-cyclohexene¹⁶³

6-Oxa-bicyclo[3.2.1]octen-5-one (**113**)(4.62g, 370mmol) and sodium methoxide (0.28g, 5mmol) were stirred in anhydrous methanol (75ml) for 10 hr. The solvent was removed *in vacuo* and the residue partitioned between ether (100ml) and 2% HCl(aq).(50ml). The aqueous phase was extracted with ether (2x100ml), and the organic phases combined, dried with magnesium sulphate and filtered. The solvent was removed under reduced pressure to give a clear yellow oil *cis*-3-hydroxy-5-carbomethoxy-1-cyclohexene (3.80g, 65%); δ_{H} (250MHz, CDCl₃, TMS) 2.058-2.753 (4H, m, ring CH₂), 3.921 (3H, s, CH₃OC), 4.892 (1H, m, CHO), 5.882 (2H, m, CH=); m/z (EI+) 156 (M⁺, 41%), 97 (M⁺-OAc, 100%).

VI.A.5.f The Synthesis of Cis-3-Acetoxy-5-carbomethoxy-1-cyclohexene (112)¹⁶³

To a cooled (ice/salt) mixture of *cis*-3-hydroxy-5-carbomethoxy-1-cyclohexene (3.80g, 240mol) in dichloromethane (50ml), and pyridine (3.6ml), was added over 10min acetyl chloride (2.3ml, 0.033mol). The resulting white slurry was stirred for 15min, neutralised with sodium hydrogen carbonate solution, and diluted with ethoxyethane (150ml). The organic phase was washed successively with saturated sodium hydrogen carbonate (3x50ml), 10% hydrochloric acid (2x50ml), sodium hydrogen carbonate solution (50ml), saturated sodium chloride (20ml), dried with magnesium sulphate and filtered. The solvent was removed under reduced pressure and the pale yellow liquid remaining purified by Kugelrohr distillation, to afford a clear colourless liquid *cis*-3-acetoxy-5-carbomethoxy-1-cyclohexene (**112**)(2.48g, 53%); b.p. 100-115°C/0.25mmHg; δ_{H} (250MHz, CDCl₃, TMS) 1.794 (1H, td, $^3J_{\text{HH}}=10.0\text{Hz}$, ring CH₂), 2.072 (3H, s, CH₃OC), 2.352 (3H, m, ring CH₂), 2.770 (1H, m, CHC=O),

3.721 (3H, s, CH_3CO), 5.427 (1H, m, CHCOAc), 5.651-5.927 (2H, m, CH=); m/z (EI+) 139 ($\text{M}^+ - \text{OAc}$, 38%).

Analysis of the product by g.c. revealed slight contamination by the *trans*-isomer, present in 3.6%.

VI.A.5.g The Attempted Reaction of *Cis*-3-Acetoxy-5-carbomethoxy-1-cyclohexene (112) with Burton's Reagent (95)

A mixture of *cis*-acetoxy-5-carbomethoxy-1-cyclohexene (**112**)(1.5640g, 7.899mmol), tetrakis(triphenylphosphine)palladium(0) (0.0600g, 0.042mmol), and oxolane (20ml) was stirred at room temperature for 1h, under a nitrogen atmosphere. Burton's reagent (**95**)(32mmol) was added and the mixture heated to reflux for 24h. ^{19}F NMR and silica gel TLC (ethyl acetate-hexane 3:1) showed no reaction, even after heating for a further 48h.

VI.A.5.h The Synthesis of Cyclopentadiene

In apparatus set up for a distillation into a cooled receiver flask (acetone/dry ice) dicyclopentadiene (200ml, 1480mmol) was heated to 160°C. The product distilled over at 57°C as a colourless clear liquid, cyclopentadiene (68.2g, 35%). The cyclopentadiene was used in the next step, without further purification.

VI.A.5.i The Synthesis of 3-Chlorocyclopentene¹⁶⁷

A rapid stream dry hydrogen chloride was added to a weighed flask of cyclopentadiene (68.2g, 1030mmol) equipped with a thermometer, gas inlet, and calcium chloride drying tube at -69°C. The reaction mixture was kept below 0°C and stirred, the flask being weighed from time to time, until the addition of hydrogen chloride was 10% short of the theoretical maximum. The 3-chlorocyclopentene was then used without further purification in the next step; δ_{H} (60MHz, CDCl_3 , TMS) 1.93-2.89 (4H, m, ring CH_2), 4.93 (1H, m, CHCl), 5.90 (2H, m, CH=).

VI.A.5.j The Synthesis of 3-Phenoxycyclopentene (114)¹⁶⁸

A mixture of phenol (55.84g, 590mmol), and sodium hydroxide (23.64g, 590mmol) in water (60ml) was stirred at 0°C for 30min after which DMF (450ml) was added to the solution and the mixture again left to cool to 0°C. 3-chlorocyclopentene (59.2g, 580mol) was then added dropwise to the solution of sodium phenoxide, and the reaction left 18h. The crude mixture was neutralised with sodium hydrogen carbonate solution followed by an ethoxyethane extraction (3x250ml). The

organic phases were combined, dried over magnesium sulphate and filtered. The solvent was then removed and the residual oil distilled *in vacuo*, to yield a pale yellow oil 3-phenoxy-cyclopentene (**114**)(9.6g, 11%); b.p. 85-86°C/0.2mmHg; δ_{H} (250MHz, CDCl_3 , TMS) 1.73-2.59 (4H, m, ring CH_2), 5.34 (1H, m, CHO), 6.11 (2H, m, $\text{CH}=\text{C}$), 7.13 (2H, d, aromatic *o*-H), 7.22 (1H, m, aromatic *p*-H), 7.44 (2H, dd, aromatic *m*-H); m/z (EI+) 160 (M^+ , 50%), 66 (M^+ -OPh, 100%).

VI.A.5.k The Attempted Reaction of 3-Phenoxy-cyclopentene (114) and Burton's Reagent (95)

A mixture of 3-phenoxy-cyclopentene (**114**)(0.2068g, 1.293mmol), tetrakis(triphenylphosphine)palladium(0) (0.0603g, 0.042mmol), and oxolane (20ml) was stirred at room temperature for 1h, under a nitrogen atmosphere. Burton's reagent (**95**)(6mmol) was added and the mixture heated to reflux for 24 hr. ^{19}F NMR and silica gel TLC (eluent ethyl acetate-hexane 1:3) showed no reaction.

VI.A.5.l The Attempted Reaction of 6-oxabicyclo[3.2.1]octen-5-one (113) and Burton's Reagent (95)

A mixture of 6-oxabicyclo[3.2.1]octen-5-one (**113**)(0.4562g, 3.650mmol), tetrakis(triphenylphosphine)palladium(0) (0.0598g, 0.042mmol), and oxolane (20ml) was stirred at room temperature for 1h, under a nitrogen atmosphere. To this solution was added Burton's reagent (**95**)(12mmol) and the mixture heated to reflux for 24h. ^{19}F NMR and silica gel TLC (eluent ethyl acetate-hexane 1:3) showed no reaction.

VI.B The Chemistry of (Diethoxyphosphinyl)difluoromethylene Lithium

VI.B.1 Synthesis of (Diethoxyphosphinyl)difluoromethane (102)²⁸⁹

To a cooled (ice/water) solution of diethyl phosphite (138.1g, 10mmol) in oxolane (400ml), under nitrogen atmosphere, sodium metal (22.9g, 10mmol). After all the sodium had reacted to give a cloudy grey solution dichlorodifluoromethane was passed at a moderate rate into the solution of sodium diethylphosphite at 30-35°C. The mixture was left stirring overnight and the precipitated sodium chloride removed by filtration (celite). The solvent was removed under reduced pressure and the residue distilled under vacuum to yield (diethoxyphosphinyl)difluoromethane (86.6g, 46%)(**102**), b.p. 86°C/12mmHg (lit b.p.85.6°C/12mmHg²⁸⁸); δ_{H} (250MHz, CDCl_3 , TMS) 1.307 (6H, t, $^3\text{J}_{\text{HH}}=7.1\text{Hz}$, CH_3), 4.216 (4H, dq, $^3\text{J}_{\text{HH}}=7.1\text{Hz}$, CH_2O), 5.852 (1H, dt, $^2\text{J}_{\text{FH}}=49.2$, $^3\text{J}_{\text{PH}}=27.0\text{Hz}$, PCF_2H); δ_{F} (235MHz, CDCl_3 , CFCl_3) -136.01 (2F, dd, $^2\text{J}_{\text{PF}}=91.6$, $^2\text{J}_{\text{FH}}=49.2\text{Hz}$, PCF_2H); m/z (EI+) 189 (MH^+ , 98%).

VI.B.2 Preparation of (Diethoxyphosphinyl)difluoromethylene Lithium (96)¹⁴⁸

To a cooled (ice/salt) solution of diisopropylamine (0.54g, 5.3 mmol) in anhydrous oxolane (20ml), under nitrogen, was added dropwise 3.65ml of 1.6M ⁿButyllithium in hexanes (5.8 mmol) the temperature never exceeding -15°C. The solution was stirred for 15min, cooled to -84°C (liquid nitrogen/ethyl acetate) and (diethoxyphosphinyl)difluoromethane (**102**)(1.02g, 5.3mmol) injected slowly into the flask, maintaining the temperature below -78°C.

The solution of (**96**) was stirred for 30min then used in a variety of experiments by subsequent injection of the substrates detailed below.

VI.B.3 Reaction of (Diethoxyphosphinyl)difluoromethylene Lithium (96) and Deuterium Oxide

To a solution of (**96**)(5.3mmol) was added deuterium oxide (0.5ml)(0.50g, 27.8mmol) the temperature never exceeding -78°C. The solution was left below -78°C for 2h then allowed to warm to room temperature. Excess ⁿbutyllithium was destroyed by injecting water, and the product extracted into ethoxyethane (150ml), washed with saturated ammonium chloride (2x50ml), dried over magnesium sulphate, filtered and isolated after removal of solvent by reduced pressure.

By NMR the products were (diethoxyphosphinyl)difluorodeuteromethane (**119**)(66%, by ¹⁹F NMR); NMR spectrum 4, and (diethoxyphosphinyl)difluoromethane (**102**)(34%, by ¹⁹F NMR); data as section VI.B.1.

VI.B.4 Reaction of (Diethoxyphosphinyl)difluoromethylene Lithium (96) with Alkyl Halides

VI.B.4.a Reaction of (Diethoxyphosphinyl)difluoromethylene Lithium (96) and Methyl Iodide

To a solution of (**96**)(5.3mmol) was added methyl iodide (0.76g, 5.4mmol) the temperature never exceeding -78°C. The solution was left below -78°C for 2h then allowed to warm to room temperature. Excess ⁿbutyllithium destroyed by injecting water, and the product extracted into ethoxyethane (150ml), washed with saturated ammonium chloride (2x50ml), dried over magnesium sulphate, filtered and isolated after removal of solvent by reduced pressure. The crude product was then purified using silica gel chromatography (eluent ethyl acetate) to afford a clear colourless liquid 1-(diethoxyphosphinyl)-1,1-difluoroethane (0.71g, 67%); δ_{H} (250MHz, CDCl₃, TMS)

1.307 (6H, t, $^3J_{\text{HH}}=7.1\text{Hz}$, CH_3), 4.216 (4H, dq, $^3J_{\text{HH}}=7.1\text{Hz}$, CH_2O), 5.852 (3H, tt, $^3J_{\text{FH}} = 18.3\text{Hz}$, PCF_2CH_3); δ_{F} (235MHz, CDCl_3 , CFCl_3) -115.01 (2F, dq, $^2J_{\text{PF}} = 91.6$, $^3J_{\text{FH}} = 18.3\text{Hz}$, PCF_2CH_3); m/z (EI+) 203 (MH^+ , 5%), 137 ($\text{M}^+-\text{CF}_2\text{Me}$, 39%).

VI.B.4.b Reaction of (Diethoxyphosphinyl)difluoromethylene Lithium (96) and Ethyl Iodide¹⁴⁸

The procedure was followed as above except ethyl iodide (0.45ml)(0.86g, 5.5 mmol) was injected. The reaction yielded 1-(diethoxyphosphinyl)-1,1-difluoropropane (0.47g, 47%), (found: C, 38.5; H, 6.8 Calc. for $\text{C}_7\text{H}_{15}\text{O}_3\text{PF}_2$: C, 38.9; H, 7.0%), δ_{F} (235MHz; CDCl_3) -114.12 ppm (2F, dt, PCF_2CH_2), δ_{H} (250MHz; CDCl_3) 1.045ppm (3H, t, $^3J_{\text{HH}}=7.9\text{Hz}$, $\text{CH}_3\text{CH}_2\text{CF}_2$), 1.305ppm (6H, t, $^3J_{\text{HH}}=6.9\text{Hz}$, $\text{CH}_3\text{CH}_2\text{O}$), 2.019ppm (2H, tq, $^3J_{\text{FH}}=19.6$, $^3J_{\text{HH}}=7.9\text{Hz}$, $\text{CH}_3\text{CH}_2\text{CF}_2$), 4.19ppm (4H, dq, $^3J_{\text{HH}}=7.9\text{Hz}$, $\text{CH}_3\text{CH}_2\text{O}$); m/z (EI+) 217 (MH^+ , 1%), 137 ($\text{M}^+-\text{CF}_2\text{Et}$, 21%).

VI.B.4.c The Reaction of (Diethoxyphosphinyl)difluoromethylene Lithium (96) and 4-Nitrophenylethane Bromide

The procedure was followed as above except a solution of 4-nitrophenylethane bromide (1.69g, 7.4mmol) in oxolane (5ml) was injected. ^{19}F and ^1H NMR showed none of the expected product, the spectra indicative of starting material.

VI.B.4.d The Reaction of (Diethoxyphosphinyl)difluoromethylene Lithium (96) and 2-Bromopropane

The procedure was followed as above except a solution of 2-bromopropane (1.11g, 9.0mmol) in oxolane (4ml) was injected. ^{19}F and ^1H NMR showed none of the expected product, the spectra indicative of starting material.

VI.B.4.e The Reaction of (Diethoxyphosphinyl)difluoromethylene Lithium (96) and Cyclobutyl Bromide

The procedure was followed as above except a solution of cyclobutyl bromide (0.50g, 3.7mmol) in oxolane (5ml) was injected. ^{19}F NMR (235MHz; CDCl_3 ; CFCl_3) showed a new product at -117.039ppm (2% by integration, dd, $^2J_{\text{FP}}=126.2$, $^3J_{\text{FH}}=19.3\text{Hz}$, CHCF_2P) which could not be isolated.

VI.B.5 Reaction of Benzylic and Allylic Halides with (Diethoxyphosphinyl)difluoromethylene Lithium (96)

VI.B.5.a The Reaction of (Diethoxyphosphinyl)difluoromethylene Lithium (96) and 1-Bromoethylbenzene

The procedure was followed as above except 1-bromoethylbenzene (1.36g, 7.33mmol) was injected. 1-(Diethoxyphosphinyl)-1,1-difluoroethylbenzene (120) (0.64g, 30%); [Found: C, 53.1; H, 6.7. (M⁺ 292) C₁₃H₁₉F₂O₃P requires C, 53.4; H, 6.55%]; b.p. 125°C/0.3mmHg; NMR spectrum 5; IR spectrum 4; mass spectrum 4.

VI.B.5.b The Reaction of (Diethoxyphosphinyl)difluoromethylene Lithium (96) and Allyl Bromide

The procedure was followed as above except allyl bromide (0.52ml)(0.86g, 6.0mmol) was injected. The reaction yielded 1-(diethoxyphosphinyl)-1,1-difluorobut-3-ene (**121**)(0.83g, 66%) (Found: C, 42.4; H, 6.4. Calc. for C₈H₁₄F₂O₃P: C, 42.3; H, 6.2%), δ_F (376MHz; CDCl₃) -111.88 (2F, dt, $^2J_{FP}$ =108.3, $^3J_{FH}$ =19.5Hz, CF₂CH₂), δ_H (400MHz; CDCl₃) 1.341 (6H, t, $^3J_{HH}$ =7.2Hz, CH₃CH₂), 2.796 (2H, m, CF₂CH₂), 4.242 (4H, dq, $^3J_{HH}$ =7.2Hz, CH₂O), 5.15ppm (1H, br s, vinylic H), 5.35ppm (1H, br s, vinylic H), 5.58-6.15ppm (1H, m, vinylic H); m/z (EI⁺) 229 (MH⁺, 100%); as compared to literature (δ_F -111.7ppm).¹⁵⁵

VI.B.5.c The Reaction of (Diethoxyphosphinyl)difluoromethylene Lithium (96) and 3-Bromocyclopentene (103)

The procedure was followed as above, except 3-bromocyclopentene (**103**)(1.09g, 4.5mmol) was injected slowly. Flash silica chromatography (ethyl acetate) yielded bis(diethoxyphosphinyl)difluoromethane (**121**)(0.19g, 18%) (Found: C, 33.4; H, 6.3. Calc. for C₉H₁₄F₂O₆P₂: C, 33.3; H, 6.2%), δ_F (235MHz; CDCl₃; CFCl₃) -122.07ppm (2F, t, $^2J_{FP}$ =86.4Hz, PCF₂P) and δ_H (400MHz; CDCl₃) 1.175ppm (12H, m, $^3J_{HH}$ =OCH₂CH₃), 4.118ppm (8H, m, OCH₂CH₃); m/z (CI⁺) 342 (MH⁺+17, 7%); as compared to literature (δ_F -122.4ppm).¹⁷²

VI.B.5.d The Reaction of (Diethoxyphosphinyl)difluoromethylene Lithium (96) and 3-Bromocyclohexene (104)

The procedure was followed as above, except 3-bromocyclohexene (**104**)(1.34g, 8.3mmol) was injected slowly. Flash silica chromatography (ethyl acetate) yielded 3-[(diethoxyphosphinyl)difluoromethyl]cyclohexene (107)(1.14g, 51%), data as recorded previously.

VI.B.5.e The Reaction of (Diethoxyphosphinyl)difluoromethylene Lithium (96) and Bromine

The procedure was followed as above, except bromine (3.71g, 20.6mmol) was injected slowly. Excess ⁿbutyllithium destroyed by injecting water, and the product extracted into ethoxyethane (150ml), washed with saturated ammonium chloride (2x50ml), dried over magnesium sulphate, filtered and isolated after removal of solvent by reduced pressure. The oil contained by ¹⁹F NMR (diethoxyphosphinyl)bromo-difluoromethane (**94**)(11.9%, by integration); δ_F (235MHz, CDCl₃, CFC1₃) -60.63 (2F, d, ³J_{PF}=93.1Hz, PCF₂Br); (diethoxyphosphinyl)difluoromethane (**102**)(60.5%, by integration); δ_F (235MHz, CDCl₃, CFC1₃) -136.01 (2F, dd, ²J_{PF}=91.6, ²J_{FH}=49.2Hz, PCF₂H); and bis[(diethoxyphosphinyl)]difluoromethane (**122**)(27.6%, by integration); δ_F (235MHz, CDCl₃, CFC1₃) -122.94 (2F, t, ³J_{PF}=86.4Hz, PCF₂P); as compared to literature (δ_F -122.4ppm).¹⁷²

VI.B.6 The Reaction of (Diethoxyphosphinyl)difluoromethylene Lithium (96) with Diacetone-D-glucose (123), a Sugar Model

VI.B.6.a Preparation of 1,2:5,6-Di-O-isopropylidene-3-O-toluene-p-sulphonyl- α -D-glucofuranose (124)¹⁷⁴

Diacetone-D-glucose (**123**)(5.96g, 22.8mmol) was dissolved in pyridine (40ml) and cooled to 0°C. Tosyl chloride (14.0g, 73.4mmol) in pyridine (20ml) was added dropwise. The solution was then stirred at room temperature for 2 days. Next water (4ml) was added and the solution left to stand for 20min. It was then poured into ice/water (300ml) and the crude tosylate filtered off. This was recrystallised from aqueous ethanol to yield 1,2:5,6-di-O-isopropylidene-3-O-toluene-p-sulphonyl- α -D-glucofuranose (**124**)(6.68g, 81%); white crystals; (Found: C, 55.1; H, 6.1. Calc. for C₁₉H₂₆O₇S: C, 55.1; H, 6.3%), δ_H (250MHz; CDCl₃, TMS) 1.15, 1.19, 1.31, and 1.48 (3H, s, (CH₃)₂C), 2.46 (3H, s, Ar-CH₃), 3.91, 4.01, 4.78, and 4.83 (multiplets, other C-H), 5.92 (1H, d, C-H), 7.59 (4H, AB system, Ar-H); m/z (CI+) 415 (MH⁺, 100%).

VI.B.6.b Preparation of 1,2:5,6-Di-O-isopropylidene-3-O-triflic- α -D-glucofuranose (125)¹⁷⁵

Diacetone-D-glucose (**123**)(1.83g, 7mmol) and pyridine (2.5g, 32mmol) were dissolved in CH₂Cl₂ (50ml) and the solution was cooled down under dry nitrogen to 0°C by an ice/salt bath. Triflic anhydride (5.1g, 18mmol) was added dropwise and the solution was stirred at 5°C for 30min. A white solid was deposited and the solution went

a pale yellow. The solution was then washed sequentially with ice-cold 2M hydrochloric acid and water. The organic layer was dried over magnesium sulphate, filtered and evaporated to leave a solid, 1,2:5,6-di-*O*-isopropylidene-3-*O*-triflic- α -D-*glucofuranose* (**125**)(2.17g, 79%), δ_F (56MHz; pyridine) -76ppm (3F, s, CF₃-Ar). The solid was used immediately.

VI.B.6.c Attempted Reaction of (Diethoxyphosphinyl)difluoro-methylene Lithium (96) and 1,2:5,6-Di-*O*-isopropylidene-3-*O*-toluene-*p*-sulphonyl- α -D-allofuranose (124)

The experimental procedure was followed as VI.B.4.a and tosylated diacetone-D-glucose (**124**)(3.00g, 7.2mmol) dissolved in oxolane (4ml) was injected. ¹⁹F NMR showed no product.

VI.B.6.d Attempted Reaction of (Diethoxyphosphinyl)difluoro-methylene Lithium (96) and 1,2:5,6-Di-*O*-isopropylidene-3-*O*-triflic- α -D-allofuranose (125)

The experimental procedure was followed as above except triflated diacetone-D-glucose (**125**)(2.00g, 5.45mmol) dissolved in oxolane (4ml) was injected. ¹⁹F NMR showed no product.

VI.B.7 Reaction of (Diethoxyphosphinyl)difluoromethylene Lithium (96) on Epoxides

VI.B.7.a The Reaction of (Diethoxyphosphinyl)difluoromethylene Lithium (96) and Oxirane

The experimental procedure was followed as above except oxirane (1.69g, 5.75mmol) was bubbled into the reaction mixture. The crude ¹⁹F NMR showed a new product at -114.1ppm (dt, ²J_{FP}=93, ³J_{FH}=18.5Hz, CHCF₂P) which could not be isolated by flash silica chromatography, eluent dichloromethane-ethyl acetate (7:3), but assumed to be 1-(diethoxyphosphinyl)-1,1-difluoropropan-3-ol (126)(42% by ¹⁹F NMR, 56MHz).

VI.C. Reactions of 3-[(Diethoxyphosphinyl)difluoromethyl]cyclohexene (107)

VI.C.1 The Synthesis of 1-[(Diethoxyphosphinyl)difluoromethyl]-2,3-epoxycyclohexene (127)

VI.C.1.a The Reaction of Magnesium monoperoxyphthalate and 3-[(Diethoxyphosphinyl)difluoromethyl]cyclohexene (107)

A flask was charged with 3-[(Diethoxyphosphinyl)difluoromethyl]cyclohexene (**107**)(2.08g, 7.8mmol) and magnesium monoperoxyphthalate (90%)(4.26g, 7.8mmol) and acetonitrile (20ml). The flask was stirred for 24h and examined by NMR. ^1H NMR showed no reaction.

VI.C.1.b The Reaction of Calcium Oxychloride and 3-[(Diethoxyphosphinyl)difluoromethyl]cyclohexene (107)

A flask was charged with 3-[(Diethoxyphosphinyl)difluoromethyl]cyclohexene (**107**)(1.01g, 3.8mmol) and calcium oxychloride (1.16g, 8.11mmol) and acetonitrile (20ml). The flask was stirred for 48h, and the contents then partitioned between chloroform (100ml) and water (40ml). The lower organic layer was retained, dried over magnesium sulphate, filtered and solvent removed under reduced pressure to yield 1-[(diethoxyphosphinyl)difluoromethyl]-2,3-epoxycyclohexene (**127**)(0.56g, 52.3%); [Found: C, 46.5; H, 6.8.(MH⁺ 285) C₁₁H₁₉F₂O₄P requires C, 46.5; H, 6.7%]; b.p. 78°C/0.5mmHg; NMR spectrum 6; IR spectrum 5; mass spectrum 5.

VI.C.1.c The Reaction of *m*-Chloroperbenzoic acid and 3-[(Diethoxyphosphinyl)difluoromethyl]cyclohexene (107)

A flask was charged with 3-[(Diethoxyphosphinyl)difluoromethyl]cyclohexene (**107**)(1.12g, 4.0mmol) and *m*-chloroperbenzoic acid (50-60%)(1.44g, 16.7mmol) and dichloromethane (20ml). The flask was stirred for 48h, and the contents then partitioned between chloroform (100ml), 1M potassium hydroxide (40ml) and water (40ml). The lower organic layer was retained, dried over magnesium sulphate, filtered and solvent removed under reduced pressure to yield 1-[(diethoxyphosphinyl)difluoromethyl]-2,3-epoxycyclohexene (**127**)(0.56g, 52.3%); (Found: C, 46.5; H, 6.8. C₁₁H₁₉F₂O₄P requires C, 46.5; H, 6.7%); b.p. 78°C/0.5mmHg; data as above.

VI.C.2 The Reaction of DAST and 1-[(Diethoxyphosphinyl)-difluoromethyl]-2,3-epoxycyclohexene (127)

A flask was charged with DAST (1ml)(1.26g, 7.82mmol) and heated with stirring to 55°C. 1-[(diethoxyphosphinyl)difluoromethyl]-2,3-epoxycyclohexene (**127**)(2.02g, 7.11mmol) was added dropwise and the reaction left stirring for 1h. ^{19}F NMR showed none of the desired product.

VI.C.3 The Reaction of Osmium Tetroxide and 3-[(Diethoxyphosphinyl)difluoromethyl]cyclohexene (107)

A flask was charged with 3-[(Diethoxyphosphinyl)difluoromethyl]cyclohexene (**107**)(2.52g, 9.1mmol), *N*-methylmorpholine-*N*-oxide (2.03g, 18.2mmol), osmium tetroxide (2.5% w/v) (0.33ml)(8.3mg, 0.03mmol) and acetone-water (20ml)(1:1). The flask was stirred for 48h, and examined by NMR. ^{19}F NMR showed no reaction.

VI.C.3 The Reaction of Silver Acetate/Water and 3-[(Diethoxyphosphinyl)difluoromethyl]cyclohexene (107)

A flask was charged with 3-[(Diethoxyphosphinyl)difluoromethyl]cyclohexene (**107**)(2.68g, 10mmol), silver nitrate (3.72g, 22mmol), iodine (2.52g, 9.9mmol) and glacial acetic acid (65ml). The flask was stirred for 4.5h, and then wet acetic acid, containing water 0.2ml (11mmol) was added and the mixture refluxed for 1h. After cooling the solids were filtered off and washed with glacial acetic acid (20ml). The washings were combined with the filtrate and evaporated under reduced pressure, diluted with water (20ml) and extracted with diethyl ether (50ml). The organic layer was washed with ammonia solution (5ml) and then the solvent removed under reduced pressure. The residue was refluxed with concentrated hydrochloric acid (10ml) for 1h, evaporated to dryness and finally extracted into chloroform and again evaporated to dryness. ^{19}F NMR showed no reaction.

CHAPTER VII**EXPERIMENTAL TO CHAPTER III****VII.A The Reaction of 3-[(Diethoxyphosphinyl)difluoromethyl]cyclohexene (107) and Selenium Dioxide**

A flask was charged with 3-[(diethoxyphosphinyl)difluoromethyl]cyclohexene (**107**)(2.398g, 8.59mmol), selenium dioxide (1.084g, 9.77mmol) and dioxane-acetic acid (11:1)(120ml). The mixture was heated under reflux for 17h, filtered through a celite plug and solvent removed *in vacuo*. The residue was partitioned between chloroform (100ml) and brine (30ml), and the organic phase then dried with magnesium sulphate. After removal of solvent the oil was refluxed for 2h with 2M H₂SO₄ (10ml) in acetonitrile (50ml), the solvent mixture remove *in vacuo* and the crude reaction mixture run down a silica column with acetone-hexane (1:1) as the eluent to yield three fractions 3-[(diethoxyphosphinyl)difluoromethyl]cyclohexene (**107**)(0.310g), a mixture of (**107**) and 6-[(diethoxyphosphinyl)difluoromethyl]cyclohexen-3-ol (**141**)(0.326g) and pure 6-[(diethoxyphosphinyl)difluoromethyl]cyclohexen-3-ol (**141**)(0.297g, 15.9%); a clear colourless oil; b.p. 187°C/2mmHg, [Found C, 46.4; H, 6.7. (M⁺-18, 276) C₁₁H₁₉F₂O₄P requires C, 46.5; H, 6.7%]; NMR spectrum 7, IR spectrum 6, mass spectrum 6.

VII.B The Reaction of 3-[(Diethoxyphosphinyl)difluoromethyl]cyclohexene (107) and N-Bromosuccinimide

A flask was charged with 3-[(diethoxyphosphinyl)difluoromethyl]cyclohexene (**107**)(9.497g, 35.4mmol), N-bromosuccinimide (6.305g, 35.4mmol), a catalytic amount of AIBN and carbon tetrachloride (50ml). The mixture was heated under reflux until succinimide was seen floating on the surface of the solvent, filtered through a celite plug and solvent removed *in vacuo*. The residue was partitioned between chloroform (100ml) and brine (30ml), the organic phase then dried (magnesium sulphate). Removal of solvent, and silica gel chromatography with acetone-hexane (2:3) as the eluent yielded 3-bromo-6-[(diethoxyphosphinyl)difluoromethyl]cyclohexene (**142**)(9.520g, 77.5%); a clear colourless oil; b.p. 145°C/0.5mmHg; [Found C, 38.0; H, 5.2; Br, 23.0. (M⁺, 347) C₁₁H₁₈BrF₂O₃P requires C, 38.1; H, 5.2; Br, 23.0%]; NMR spectrum 8; IR spectrum 7; mass spectrum 7.

VII.C The Reaction of 3-bromo-6-[(diethoxyphosphinyl)difluoromethyl]cyclohexene (142) and 6-Chloropurine (144)

A flask was charged with 3-bromo-6-[(diethoxyphosphinyl)difluoromethyl]cyclohexene (**142**)(5.41035g, 15.59mmol), 6-chloropurine (**144**)(2.41248g, 15.60mmol) and potassium carbonate (2.17143g, 15.60mmol) in dimethylformamide (DMF)(150ml) and stirred at room temperature for 12h. Solvent was removed under reduced pressure and the residue was partitioned between chloroform (100ml) and brine (30ml), the organic phase dried (magnesium sulphate). Removal of the solvent, and silica gel chromatography eluent ethyl acetate yielded a white solid 3-[N9-(6-chloropuriny)]-6-[(diethoxyphosphinyl)difluoromethyl]cyclohexene as two separable isomers, eluent hexane-ethyl acetate (2:3), (**145a**) and (**145b**)(2.443g, 46.1%); m.p.159°C, [Found C, 45.9; H, 4.9; Cl, 8.4; N, 13.1. (MH⁺, 421) C₁₆H₂₀ClF₂N₄O₃P requires C, 45.7; H, 4.8; Cl, 8.4; N, 13.3%]; λ_{max} (CH₃CN) 265nm (log₁₀ε 5.8); NMR spectrum 9; IR spectrum 8; mass spectrum 8.

VII.D The Attempted Synthesis of 3-[N9-(Adenyl)]-6-[(diethoxyphosphinyl)difluoromethyl]cyclohexene (147)

VII.D.1 The Reaction of 3-[N9-(6-Chloropuriny)]-6-[(diethoxyphosphinyl)difluoromethyl]cyclohexene (145) and Sodium Azide

A flask was charged with sodium azide (114.68mg, 1.76mmol) and 3-[N9-(6-chloropuriny)]-6-[(diethoxyphosphinyl)difluoromethyl]cyclohexene (**145**)(471.02mg, 1.12mmol) in DMF (30ml) and heated at 70°C for 18h. The solution was extracted with chloroform (100ml), washed with water (2x50ml), and the organic phase dried (magnesium sulphate). The solvent was removed under reduced pressure and the crude oil purified by silica gel chromatography with acetone-hexane-methanol (4:2:1) as the eluent to yield a white solid assumed to be the azide (0.396g, 82.8%). This was used immediately in the next stage.

VII.D.2 The Reaction of 3-[N9-(6-Azidopuriny)]-6-[(diethoxyphosphinyl)difluoromethyl]cyclohexene and Triphenylphosphine

A mixture of 3-[N9-(6-azidopuriny)]-6-[(diethoxyphosphinyl)difluoromethyl]cyclohexene (222mg, 0.519mmol), and triphenylphosphine (238.72mg, 0.911mmol) in dimethyl sulphoxide (30ml) were stirred for 5h. The solvent was removed under reduced pressure, the solid residue added to a mixture of water (10ml) and 2M hydrochloric acid (5ml) and stirred for 15h. A white precipitate, triphenylphosphine, was filtered off and the solvent removed under reduced pressure from the filtrate. The crude solid was

purified by silica gel chromatography with dichloromethane-methanol (5:1) as the eluent to yield an unidentified white solid 183.11mg, which was not the desired product.

VII.D.3 The Reaction of 3-[N9-(6-Chloropuriny)]-6-[(diethoxyphosphinyl)difluoromethyl]cyclohexene (145) and Sodium Amide

A flask was charged with sodium amide (4.2mg, 0.108mmol) and 3-[N9-(6-chloropuriny)]-6-[(diethoxyphosphinyl)difluoromethyl]cyclohexene (**145**)(44.7mg, 0.106mmol) in anhydrous DMF (20ml), under nitrogen, and stirred for 18h. A TLC (silica)(eluent ethyl acetate) indicated no reaction.

VII.D.4 The Reaction of 3-[N9-(6-Chloropuriny)]-6-[(diethoxyphosphinyl)difluoromethyl]cyclohexene (145) and Liquid Ammonia

A quartz tube was charged with 3-[N9-(6-chloropuriny)]-6-[(diethoxyphosphinyl)difluoromethyl]cyclohexene (**145**)(17.2mg, 0.041mmol) and liquid ammonia condensed into the tube, using vacuum line techniques. The tube was sealed and rocked for 18h. The tube was frozen, the top removed and then left to warm to room temperature. A silica TLC (eluent ethyl acetate) of the remaining white solid indicated no reaction.

VII.D.5 The Reaction of 3-[N9-(6-Chloropuriny)]-6-[(diethoxyphosphinyl)difluoromethyl]cyclohexene (145) and Alcoholic Ammonia Solution

A solution of 3-[N9-(6-chloropuriny)]-6-[(diethoxyphosphinyl)difluoromethyl]cyclohexene (**145**)(216.49mg, 0.515mmol) in fresh saturated methanolic ammonia solution (30ml) was heated in an autoclave tube for 6h at 100°C. Solvent was removed under reduced pressure and the crude residue purified by silica gel chromatography with chloroform-methanol (5:1) as eluent to yield a white solid 3-(N9-adenyl)-6-[(diethoxyphosphinyl)difluoromethyl]cyclohexene (**147**)(2.31mg, 1.1%); NMR spectrum 10; IR spectrum 9; mass spectrum 9.

VII.D.6 The Reaction of 3-[N9-(6-Chloropuriny)]-6-[(diethoxyphosphinyl)difluoromethyl]cyclohexene (145) and Silver (I) Fluoride

A flask was charged with silver (I) fluoride (18.5mg, 0.146mmol) and 3-[N9-(6-chloropuriny)]-6-[(diethoxyphosphinyl)difluoromethyl]cyclohexene (**145**)(39.4mg, 0.094mmol) in toluene (20ml) and heated at reflux for 1.5h. A TLC (silica)(eluent ethyl acetate) indicated no reaction.

VII.D.7 The Reaction of 3-[N9-(6-Chloropuriny)]-6-[(diethoxyphosphinyl)difluoromethyl]cyclohexene (145) and Silver (II) Fluoride

A flask was charged with silver (II) fluoride (12.9mg, 0.089mmol) and 3-[N9-(6-chloropuriny)]-6-[(diethoxyphosphinyl)difluoromethyl]cyclohexene (**145**)(37.2mg, 0.089mmol) in chloroform (30ml) and heated at reflux for 8h. A TLC (silica)(eluent ethyl acetate) indicated a complex mixture.

VII.D.8 The Reaction of 3-[N9-(6-Chloropuriny)]-6-[(diethoxyphosphinyl)difluoromethyl]cyclohexene (145) and Aqueous Ammonia /Dioxan Solution

A solution of 3-[N9-(6-chloropuriny)]-6-[(diethoxyphosphinyl)difluoromethyl]-cyclohexene (**145**)(5.410g, 15.6mmol) in dioxan-0.88 ammonia solution (1:1)(10ml) was heated in a sealed tube for 12h at 100°C. The contents of the tube were frozen and the top removed, after thawing they were transferred to a flask; solvent was removed under reduced pressure and the residue chromatographed on silica gel with chloroform-methanol (5:1) as eluent to yield a white solid 3-(N9-adenyl)-6-[(diethoxyphosphinyl)difluoromethyl]cyclohexene (**147**)(2.443g, 66.1%); m.p.234-236°C, [Found C, 47.9; H, 5.4; N, 17.6. (M⁺, 401) C₁₆H₂₂F₂N₅O₃P requires C, 47.9; H, 5.5; N, 17.45%]; λ_{max} (CH₃OH) 262nm (log₁₀ε 4.7); NMR spectrum 10; IR spectrum 9; mass spectrum 9.

VII.E The Reaction of 3-(N9-Adenyl)-6-[(diethoxyoxyphosphinyl)-difluoromethyl]cyclohexene (147) and Trimethylsilyl Bromide

A suspension of 3-(N9-adenyl)-6-[(diethoxyphosphinyl)difluoromethyl]-cyclohexene (**147**)(1.341g, 3.34mmol) in trimethylsilyl bromide (5.120g, 33.44mmol), under nitrogen, was stirred for 16h. The solvent was removed under reduced pressure and the crude solid material was added to 2M hydrochloric acid (10ml) and stirred for a further 3h. Again the solvent was removed under reduced pressure and the residue chromatographed on C18 reverse phase silica gel, eluent water, to yield 3-(N9-adenyl)-6-[(dihydroxyphosphinyl)difluoromethyl]cyclohexene (**139**)(0.843g, 73.2%); a white solid; m.p.254°C, [Found C, 41.7; H, 4.1; N, 20.6. (M⁺, 345) C₁₂H₁₄F₂N₅O₃P requires C, 41.7; H, 4.1; N, 20.3%]; λ_{max} (CH₃OH) 262nm (log₁₀ε 5.3); NMR spectrum 11; IR spectrum 10; mass spectrum 10.

VII.F The Reaction of 3-bromo-6-[(diethoxyphosphinyl)difluoromethyl]cyclohexene (142) and 2-amino-6-chloropurine (148)

A mixture of 3-bromo-6-[(diethoxyphosphinyl)difluoromethyl]cyclohexene (**142**) (1.514g, 4.4mmol), 2-amino-6-chloropurine (**148**) (0.753g, 4.4mmol) and potassium carbonate (0.616g, 4.5mmol) in DMF (100ml) was stirred at room temperature for 12h. Solvent was removed under reduced pressure and the residue was partitioned between chloroform (100ml) and brine (30ml) and the organic phase dried (magnesium sulphate). Removal of the solvent, and silica gel chromatography with ethyl acetate as eluent yielded 3-[N9-(2-amino-6-chloropurinyl)]-6-[(diethoxyphosphinyl)difluoromethyl]cyclohexene (**149**) as two inseparable isomers (0.428g, 30.6%); m.p. 169°C, [Found C, 43.5; H, 4.8; N, 15.7; Cl, 8.0. (MH⁺, 436) C₁₆H₂₁ClF₂N₅O₃P.0.25H₂O requires C, 43.6; H, 4.8; Cl, 8.1; N, 15.9%]; λ_{max} (CH₃CN) 247, 306nm (log₁₀ε 6.1, 5.5); NMR spectrum 12; IR spectrum 11; mass spectrum 11.

VII.G The Reaction of 3-[(diethoxyphosphinyl)difluoromethyl]-6-(N9-guanyl)cyclohexene (149) and Aqueous Hydrochloric Acid

A suspension of 3-[(diethoxyphosphinyl)difluoromethyl]-6-(N9-guanyl)cyclohexene (**149**) (0.83g, 1.9mmol) in 2M hydrochloric acid (10ml) and water (100ml) was heated at reflux for 3h. The solution was evaporated to dryness to leave an off-white/yellow solid. The crude material was purified by C18 silica gel chromatography, eluent water, to yield 3-[(ethoxyhydroxyphosphinyl)difluoromethyl]-6-(N9-guanyl)cyclohexene (**151**) (0.61g, 83.0%); a white solid; m.p. 210-211°C, [Found C, 42.9; H, 4.9; N, 17.9. (M⁺, 389) C₁₄H₁₈F₂N₅O₄P requires C, 43.2; H, 4.7; N, 18.0%]; λ_{max} (CH₃OH) 256nm (log₁₀ε 4.1); NMR spectrum 13; IR spectrum 12; mass spectrum 12.

VII.H The Reaction of 3-[(ethoxyhydroxyphosphinyl)difluoromethyl]-6-(N9-guanyl)cyclohexene (151) and Trimethylsilyl Bromide

A suspension of 3-[(ethoxyhydroxyphosphinyl)difluoromethyl]-6-(N9-guanyl)cyclohexene (**151**) (0.46g, 1.2mmol) in trimethylsilyl bromide (8.47g, 55.3mmol) was stirred for 16h. Solvent was removed under reduced pressure and the crude solid added to 2M hydrochloric acid (10ml) and stirred for a further 3h. The solvent was removed under reduced pressure and the residue chromatographed on C18 reverse phase silica gel, eluent water, to yield 3-[(dihydroxyphosphinyl)difluoromethyl]-6-guanyl cyclohexene (**140**) (0.38g, 87.7%); a white solid; m.p. 245°C, [Found C, 39.9; H, 3.9; N, 19.1. (M⁺, 361) C₁₂H₁₄F₂N₅O₄P requires C, 39.9; H, 3.9; N, 19.4%]; λ_{max} (CH₃OH) 255nm (log₁₀ε 4.3); NMR spectrum 14; IR spectrum 13; mass spectrum 13.

CHAPTER VIII**EXPERIMENTAL TO CHAPTER IV****VIII.A General Method to Charge a Carius Tube**

A Carius tube (60ml) was first charged with the liquid reagents and consequently degassed by the freeze-thaw method, three cycles, utilising vacuum line techniques and sealed *in vacuo*.

VII.B Utilising Gamma-ray Irradiation**VIII.B.1 The Reaction of (Diethoxyphosphinyl)bromodifluoromethane (94) and Cyclohexene**

A Carius tube was charged with (diethoxyphosphinyl)bromodifluoromethane (**94**)(2.37g, 8.8mmol) and an excess of freshly distilled cyclohexene (7.80g, 95.1mmol). The tube was irradiated at a fixed distance from a ^{60}Co gamma-ray source, for a total of 9.3MRads, and the opened and the contents heated at 70°C for 4h under full vacuum to remove any cyclohexene. The crude reaction mixture was then distilled in a Kugelrohr apparatus to yield 1-bromo-2-[(diethoxyphosphinyl)difluoromethyl]-cyclohexane (**153**)(0.34g, 41.2%); a clear colourless oil; b.p. 134°C/0.1mmHg; [Found C, 38.0; H, 5.9. (M^+ 348/350) $\text{C}_{11}\text{H}_{20}\text{O}_3\text{BrF}_2\text{P}$ requires C, 37.8; H, 5.8%]; NMR spectrum 16; IR spectrum 15; mass spectrum 15, and (diethoxyphosphinyl)difluoromethane (**102**)(0.21g, 44.4%); b.p. 88°C/12mmHg (lit b.p.85.6°C/12mmHg²⁸⁸); m/z (EI+) 187 (M^+-1 , 100%).

VIII.B.2 The Synthesis of [Bis(trimethylsiloxy)phosphinyl]bromodifluoromethane (155)

A mixture of (diethoxyphosphinyl)bromodifluoromethane (**94**)(3.38g, 12.7mmol) and trimethylsilyl bromide (5.00g, 32.7mmol) was stirred for 18h and then refluxed for 30min, under nitrogen. The crude mixture was then distilled under vacuum to yield [bis(trimethylsiloxy)phosphinyl]bromodifluoromethane (**155**)(2.39g, 53.5%) as a clear colourless oil; b.p.61-63°C/0.4mmHg; NMR spectrum 15; IR spectrum 14.

VIII.B.3 The Synthesis of (Dihydroxyphosphinyl)bromodifluoromethane (154)

A flask was charged with [bis(trimethylsiloxy)phosphinyl]bromodifluoromethane (**155**)(2.39g, 6.8mmol) and water (40ml), then the mixture was stirred for 48h. The volatiles were removed under vacuum to afford a viscous liquid, which was left in a vacuum dessicator, over phosphorus pentoxide, until of constant mass, yielding (dihydroxyphosphinyl)bromodifluoromethane (154)(1.15g, 78.8%); viscous liquid; (MH⁺+NH₃ 229), NMR spectrum 16; IR spectrum 15; mass spectrum 14.

VIII.B.4 The Reaction of (Dihydroxyphosphinyl)bromodifluoromethane (154) and Cyclohexene

A Carius tube was charged with (dihydroxyphosphinyl)bromodifluoromethane (**154**)(1.15g, 5.3mmol), an excess of freshly distilled cyclohexene (4.35g, 53.0mmol), 2,2,2-trifluoroethanol (4ml). The tube was irradiated at a fixed distance from a ⁶⁰Co gamma-ray source, for a total of 9.3MRads, and then removed, opened and the contents heated at 70°C for 4h under full vacuum to remove any cyclohexene and 2,2,2-trifluoroethanol. The crude reaction mixture was purified by C18 reverse phase chromatography, eluent water, to yield (dihydroxyphosphinyl)difluoromethane (**157**)(0.21g, 44.4%); δ_F (235MHz, CDCl₃, CFCl₃) -116.75 (2F, dd, ²J_{PF}=112.5, ²J_{FH}=13.4Hz, PCF₂H) and 1-bromo-2-[(dihydroxyphosphinyl)difluoromethyl]-cyclohexane (156)(0.34g, 41.2%); b.p. 145°C/0.05mmHg; [Found C, 28.1; H, 5.0 (M⁺+NH₃ 309/311) C₁₁H₂₀O₃BrF₂P requires C, 28.7; H, 4.1%]; NMR spectrum 17; IR spectrum 16; mass spectrum 15.

VIII.C Utilising U.V. Irradiation

VIII.C.1 The Reaction of (Diethoxyphosphinyl)bromodifluoromethane (94) and Cyclohexene

A Carius tube was charged with (diethoxyphosphinyl)bromodifluoromethane (**94**)(7.98g, 29.9mmol) and an excess of freshly distilled cyclohexene (8.11g, 98.9mmol). The tube was then irradiated at a fixed distance from a medium pressure mercury arc lamp for a total of 72h, opened and the contents heated at 70°C for 4h under full vacuum to remove any cyclohexene. The crude reaction mixture was then distilled under vacuum to yield 1-bromo-2-[(diethoxyphosphinyl)difluoromethyl]cyclohexane (153)(2.28g, 35.8%); data as above, and (diethoxyphosphinyl)difluoromethane (**102**)(0.31g, 9.0%); data as section VI.B.1.

VIII.C.2 The Reaction of (Diethoxyphosphinyl)bromodifluoromethane (94), Cyclohexene and Benzophenone

A Carius tube was charged with (diethoxyphosphinyl)bromodifluoromethane (**94**)(7.60g, 28.5mmol), an excess of freshly distilled cyclohexene (9.32g, 113.7mmol) and benzophenone (0.35g, 1.9mmol). It was then irradiated at a fixed distance from a medium pressure mercury arc lamp for a total of 72h, opened and the contents heated at 70°C for 4h under full vacuum to remove any cyclohexene. ^{19}F NMR revealed (diethoxyphosphinyl)bromodifluoromethane (**94**)(72.7% yield by integration), 1-bromo-2-[(diethoxyphosphinyl)difluoromethyl]cyclohexane (**153**)(18.2% yield by integration) and (diethoxyphosphinyl)difluoromethane (**102**)(9.1% yield by integration). All chemical shifts were in agreement to authentic samples.

VIII.C.3 The Synthesis of (Diethoxyphosphinyl)difluoroiodomethane (118)

Under a nitrogen atmosphere a mixture of (diethoxyphosphinyl)-bromodifluoromethane (**94**)(23.67g, 88.7mmol), cadmium dust (9.97g, 88.7mmol) in DMF (100ml) was for 18h. To this solution was then injected iodine (22.54g, 88.7mmol) in DMF (40ml). The solution was left stirring for a further 24h. The crude mixture was distilled under vacuum to remove DMF and then extracted with ethoxyethane (2x50ml), saturated sodium metabisulphite (2x100ml) and dried with magnesium sulphate. Vacuum distillation yielded (diethoxyphosphinyl)difluoroiodomethane (**118**)(12.09g, 43.4%) as a clear pale yellow oil; b.p.61-63°C/0.4mmHg; (Found C, 19.1; H, 3.1. Calc for $\text{C}_{11}\text{H}_{20}\text{F}_2\text{IPO}_3$: C, 19.1; H, 3.2%); IR spectrum recorded; δ_{H} (250MHz, CDCl_3 , TMS) 1.45 (6H, t, $^3\text{J}_{\text{HH}}=7.2\text{Hz}$, CH_3), 4.33 (4H, dq, $^3\text{J}_{\text{HH}}=7.2\text{Hz}$, CH_2O); δ_{F} (235MHz, CDCl_3 , CFCl_3) -60.63 (2F, d, $^2\text{J}_{\text{PF}}=93.1\text{Hz}$, PCF_2I); m/z (CI+) 314 (MH^++NH_3 , 98%), 284 (MH^++NH_3 , 100%); as compared to literature data δ_{F} -58.6ppm.¹⁴²

VIII.C.4 The Reaction of (Diethoxyphosphinyl)difluoroiodomethane (118) and Cyclohexene

A Carius tube was charged with (diethoxyphosphinyl)difluoroiodomethane (**118**)(7.98g, 25.4mmol) and an excess of freshly distilled cyclohexene (8.11g, 98.9mmol). It was then irradiated at a fixed distance from a medium pressure mercury arc lamp for a total of 72h, opened and the contents heated at 70°C for 4h under full vacuum to remove any cyclohexene. The crude reaction mixture was then Kugelrohr distilled under vacuum to yield 1-[(diethoxyphosphinyl)difluoromethyl]-2-iodocyclohexane (**159**)(4.98g, 53.2%); b.p. 125°C/0.05mmHg; [Found C, 33.5; H,

5.1. (M^+ 396) Calc for $C_{11}H_{20}F_2IPO_3$: C, 33.35; H, 5.1%]; NMR spectrum 18; IR spectrum 17; mass spectrum 16 and (diethoxyphosphinyl)difluoromethane (**102**)(0.87g, 19.6%); data as section VI.B.1.

VIII.C.5 The Reaction of (Diethoxyphosphinyl)difluoroiodomethane (118) and Cyclopentene

A Carius tube was charged with (diethoxyphosphinyl)difluoroiodomethane (**118**) (7.97g, 25.4mmol) and an excess of freshly distilled cyclopentene (7.90g, 116.1mmol). It was irradiated at a fixed distance from a medium pressure mercury arc lamp for a total of 72h, opened and the contents heated at 70°C for 4h under full vacuum to remove any cyclopentene. The crude reaction mixture was then Kugelrohr distilled under vacuum to yield 1-[(diethoxyphosphinyl)difluoromethyl]-2-iodocyclopentene (160)(2.30g, 33.9%); b.p. 120°C/0.05mmHg; [Found C, 31.4; H, 4.8. $C_{10}H_{18}F_2IPO_3$ requires C, 31.4; H, 4.75%]; NMR spectrum 19; IR spectrum 18; mass spectrum 17. and (diethoxyphosphinyl)difluoromethane (**102**)(1.52g, 30.4%); b.p. 76°C/8mmHg (lit b.p.85.6°C/12mmHg²⁸⁸).

VIII.C.6 The Reaction of (Diethoxyphosphinyl)difluoroiodomethane (118) and Cycloheptene

A 60ml Carius tube was charged with (diethoxyphosphinyl)difluoroiodomethane (**118**)(8.41g, 26.8mmol) and an excess of freshly distilled cycloheptene (8.40g, 87.5mmol). It was then irradiated at a fixed distance from a medium pressure mercury arc lamp for a total of 72h, opened and the contents heated at 70°C for 4h under full vacuum to remove any cycloheptene. Then the crude reaction mixture was Kugelrohr distilled under vacuum to yield 1-[(diethoxyphosphinyl)difluoromethyl]-2-iodocycloheptane (161)(6.33g, 67.0%); b.p. 125°C/0.05mmHg; [Found C, 35.1; H, 5.6. (MH^+ 411) $C_{12}H_{22}F_2IPO_3$ requires C, 35.1; H, 5.4%]; NMR spectrum 20; IR spectrum 19; mass spectrum 18; and (diethoxyphosphinyl)difluoromethane (**102**)(0.46g, 10.5%); b.p. 75-77°C/8mmHg (lit b.p.85.6°C/12mmHg²⁸⁸).

VIII.C.7 The Reaction of (Diethoxyphosphinyl)difluoroiodomethane (118) and 2,3-Dihydrofuran

A Carius tube was charged with (diethoxyphosphinyl)difluoroiodomethane (**118**)(3.27g, 10.4mmol) and an excess of 2,3-dihydrofuran (4.68g, 66.9mmol). It was irradiated at a fixed distance from a medium pressure mercury arc lamp for a total of 72h, then opened and the contents heated at 70°C for 4h under full vacuum to remove any 2,3-dihydrofuran. ^{19}F NMR showed no evidence of reaction.

VIII.C.8 The Reaction of (Diethoxyphosphinyl)difluoroiodomethane (118) and 3,4-Dihydrofuran

A Carius tube was charged with (diethoxyphosphinyl)difluoroiodomethane (**118**) (7.67g, 24.4mmol) and an excess of 2,5-dihydrofuran (13.41g, 98.9mmol). It was irradiated at a fixed distance from a medium pressure mercury arc lamp for a total of 72h, and then opened and the contents heated at 70°C for 4h under full vacuum to remove any 3,4-dihydrofuran. ¹⁹F NMR showed a 4% conversion to the products 3-[(diethoxyphosphinyl)difluoromethyl]-4-iodooxolane (**163**)(50% yield by integration) NMR spectrum 21; and (diethoxyphosphinyl)difluoromethane (**102**)(50% yield by integration) data section VI.B.1.

VIII.C.9 The Reaction of (Diethoxyphosphinyl)difluoroiodomethane (118) and Furan

A Carius tube was charged with (diethoxyphosphinyl)difluoroiodomethane (**118**)(7.63g, 24.3mmol) and an excess of furan (8.11g, 119.3mmol). It was irradiated at a fixed distance from a medium pressure mercury arc lamp for a total of 72h, and then opened and the contents heated at 70°C for 4h under full vacuum to remove any furan. ¹⁹F NMR showed a 2% conversion to the products 3-[(diethoxyphosphinyl)difluoromethyl]-2,3-dihydro-2-iodooxolane or 2-[(diethoxyphosphinyl)difluoromethyl]-2,3-dihydro-3-iodooxolane (**164**)(50% yield by integration) NMR spectrum 22; and (diethoxyphosphinyl)difluoromethane (**102**)(50% yield by integration) data section VI.B.1.

VIII.D SET Reactions

VIII.D.1 The Attempted Reaction of (Diethoxyphosphinyl)bromodifluoromethane (94) and Cyclohexene utilising Copper Catalysis

A flask charged with (diethoxyphosphinyl)bromodifluoromethane (**94**)(2.46g, 9.2mmol), cyclohexene (4.93g, 60.1mmol) and DMF (10ml) was stirred at 70°C for 18h. ¹⁹F NMR of the crude mixture showed no evidence of reaction.

VIII.D.2 The Attempted Reaction of (Diethoxyphosphinyl)bromodifluoromethane (94) and Cyclohexene utilising Samarium Diiodide

Under a nitrogen atmosphere samarium diiodide-oxolane solution (2.5ml, 0.10M) was injected into a flask charged with (diethoxyphosphinyl)bromodifluoromethane

(94)(1.46g, 5.5mmol), cyclohexene (0.49g, 6.0mmol) and oxolane (6ml). The mixture was left stirring for 1h and then a further 24h, ^{19}F NMR showed no evidence of reaction.

VIII.D.3 The Attempted Reaction of (Diethoxyphosphinyl)difluoroiodomethane (118) and Cyclohexene utilising Samarium Diiodide

Under a blanket of nitrogen, samarium diiodide-oxolane solution (0.5ml, 0.10M) was injected into a flask charged with (diethoxyphosphinyl)difluoroiodomethane (118)(0.28g, 0.9mmol), cyclohexene (0.10g, 1.2mmol) and oxolane (6ml). The mixture was left stirring for 1h and then a further 48h, ^{19}F NMR showed no evidence of reaction.

CHAPTER IX

EXPERIMENTAL TO CHAPTER V

IX.A General Procedure for the Synthesis of Fluorinated Ethers

Free radical addition was initiated by gamma-ray irradiation (*ca.* 9.3MRads), achieved, by exposure at room temperature to a ^{60}Co source, housed in a purpose-built chamber. All addition reactions were carried out in glass Carius tubes of *ca.* 100ml. The liquid reagents were added to the tube and degassed. Gaseous reagents were vacuum transferred into the tube. Degassing was accomplished by three freeze thaw cycles. Normal vacuum line techniques were used for these procedures. The tube was sealed with the reactants frozen (liquid air) and under vacuum.

IX.B Synthesis of Acyclic Fluoroethers

IX.B.1 Synthesis of Methoxy-2,2,3,4,4,4-hexafluorobutane (173)²⁶¹

A mixture of methoxymethane (13.1g, 0.285mol) and hexafluoropropene (HFP) (15.91g, 0.11mol) was irradiated at a fixed distance from a ^{60}Co gamma source. After 4 days (9MRads of radiation) the tube was removed and the excess ether was allowed to evaporate to leave a colourless liquid. Distillation gave 1-methoxy-2,2,3,4,4,4-hexafluorobutane (**173**)(16.0g, 75%); b.p. 87°C, (Found C, 30.5; H, 3.1. Calc. for $\text{C}_5\text{H}_6\text{F}_6\text{O}$: C, 30.6; H, 3.1%); NMR spectrum 25; .m/z (EI+) 196 (MH^++NH_3 , 98%), 284 (MH^++NH_3 , 100%).

IX.B.2 Synthesis of 1-Methoxy-2,2,4,4,4-pentafluorobutane (174)

A mixture of methoxymethane (2.17g, 47.1mmol) and pentafluoropropene (5.30g, 40.0mmol) was irradiated at a fixed distance from a ^{60}Co gamma source. After 4 days (9MRads of radiation) the tube was removed and the excess ether was allowed to evaporate to leave a colourless liquid. Distillation gave 1-methoxy-2,2,4,4,4-pentafluorobutane (174)(0.59g, 8.3%); b.p. 75°C/51mmHg, [Found C, 33.7; H, 4.4 (M^+-1 177) $\text{C}_5\text{H}_7\text{F}_5\text{O}$ requires C, 33.7; H, 4.0%]; NMR spectrum 26; IR spectrum 22; mass spectrum 21.

IX.B.3 Attempted Synthesis of 1-Methoxy-4,4,4-trifluorobutane (175)

A mixture of methoxymethane (3.50g, 76mmol) and trifluoropropene (3.15g, 32.8mmol) was irradiated at a fixed distance from a ^{60}Co gamma source. After 4 days

(9MRads of radiation) the tube was removed and the excess ether was allowed to evaporate to leave a viscous colourless liquid which was not 1-methoxy-4,4,4-trifluorobutane but a high polymer (**175**) [Found C, 38.5; H, 3.5; F, 54.4%. ($M^+ > 261$) Empirical formula $C_{14.3}H_{15.6}F_{12.8}O$]; NMR spectrum 27; IR spectrum 23; mass spectrum 22.

IX.B.4 Competition Reactions

IX.B.4.a Competition of 3,3,3-Trifluoropropene and Hexafluoropropene for Methoxymethane

A mixture of 3,3,3-trifluoropropene (3.41g, 35.5mmol), hexafluoropropene (5.35g, 35.7mmol) and methoxymethane (0.39g, 8.3mmol) was irradiated at a fixed distance from a ^{60}Co gamma source. After 4 days (9MRads of radiation) the tube was removed and the excess ether was allowed to evaporate to leave the viscous colourless liquid the polymeric 3,3,3-trifluoropropene adduct (**175**) as the only product verified by ^{19}F NMR.

IX.B.4.b Competition of 1,1,3,3,3-Pentafluoropropene and Hexafluoropropene for Methoxymethane

A mixture of 1,1,3,3,3-pentafluoropropene (4.36g, 33.0mmol), hexafluoropropene (4.95g, 33.0mmol) and methoxymethane (0.31g, 6.6mmol) was irradiated at a fixed distance from a ^{60}Co gamma source. After 4 days (9MRads of radiation) the tube was removed and the excess ether was allowed to evaporate to leave 1-methoxy-2,2,3,4,4,4-hexafluorobutane (**173**), verified by ^{19}F NMR. and gas chromatography.

IX.B.4.c Competition of 3,3,3-Trifluoropropene and 1,1,3,3,3-Pentafluoropropene for Methoxymethane

A mixture of 3,3,3-trifluoropropene (2.96g, 30.8mmol), 1,1,3,3,3-pentafluoropropene (4.08g, 30.9mmol) and methoxymethane (0.30g, 6.4mmol) was irradiated at a fixed distance from a ^{60}Co gamma source. After 4 days (9MRads of radiation) the tube was removed and the excess ether was allowed to evaporate to leave the viscous colourless liquid the polymeric 3,3,3-trifluoropropene adduct (**175**) as the only product verified by ^{19}F NMR.

IX.C Synthesis of Cyclic Fluoroethers

IX.C.1 Synthesis of 2-(1,1,2,3,3,3-Hexafluoropropyl)oxolane (176)²⁵³

A mixture of oxolane (9.04g, 0.126mol) and hexafluoropropene (13.52g, 0.09mol) was irradiated at a fixed distance from a ⁶⁰Co gamma source. After 4 days (9MRads of radiation) the tube was removed and the excess ether was allowed to evaporate to leave a colourless liquid. Distillation gave 2-(1,1,2,3,3,3-Hexafluoropropyl)oxolane (**176**)(12.0g, 80.7%); b.p. 45-48°C/20mmHg; (Found: C, 37.5; H, 3.8. Calc. for C₇H₈F₆O: C, 37.85; H, 3.6%); δ_{H} (400MHz, CDCl₃, TMS) 1.9 (1H, dt, ²J_{HH}=20.0, ³J_{HH}=5.6Hz, ring CH), 2.0 (1H, dt, ²J_{HH}=20.0, ³J_{HH}=5.6Hz, ring CH), 2.069 (1H, dd, ²J_{HH}=23.6, ³J_{HH}=5.6Hz, ring CH), 2.174 (1H, ddd, ²J_{HH}=13.6, ³J_{HH}=13.2, ³J_{HH}=5.6Hz, ring CH), 3.882 (1H, d, ²J_{HH}=6.9Hz, ring CH₂O), 3.912 (1H, d, ²J_{HH}=6.9Hz, ring CH₂O), 4.305 (1H, dtt, ³J_{HH}=13.2, ³J_{HF}=12.8, ³J_{HF}=4.4Hz, ring CHCF₂), 5.082 (1H, ddq, ²J_{HF}=42.8, ³J_{HF}=20.8, ³J_{HF}=6.4Hz, ring CHCF₂); δ_{F} (376MHz, CDCl₃, CFCl₃) -74.19 (3F, dddd, ³J_{FH}=22.2, ³J_{FF}=10.5, ⁴J_{FF}=6.4, ⁴J_{FF}=0.8Hz, CF₃), -120.10 (1F, ddqd, ²J_{FF}=269.8, ³J_{FF}=9.0, ⁴J_{FF}=9.0, ³J_{FF}=4.5Hz, CF₂), -124.26 (1F, ddqdd, ²J_{FF}=269.8, ³J_{FF}=12.5, ⁴J_{FF}=12.5, ³J_{FH}=12.5, ³J_{FH}=12.5Hz, CF₂), 213.29 (1F, ddqdd, ²J_{FH}=42.8, ³J_{FF}=14.3, ³J_{FF}=10.5, ³J_{FF}=10.5, ⁴J_{FH}=3.8Hz, CFH); m/z (EI+) 221 (M⁺-1, 0.7%), 71 (M⁺-C₃F₆H, 100%).

IX.C.2 Synthesis of 2-(1,1,3,3,3-Pentafluoropropyl)oxolane (177)

A mixture of oxolane (23.06g, 0.320mol) and pentafluoropropene (16.12g, 0.122mol) was irradiated at a fixed distance from a ⁶⁰Co gamma source. After 4 days (9MRads of radiation) the tube was removed and the excess ether was allowed to evaporate to leave a colourless liquid. Distillation gave 2-(1,1,3,3,3-pentafluoropropyl)-oxolane (**177**)(18.61g, 75%); b.p. 52°C/21mmHg; [Found: C, 37.9; H, 3.6 (M⁺-1 203) C₇H₉F₅O requires C, 37.85; H, 3.6%]; NMR spectrum 28; IR spectrum 24; mass spectrum 23.

IX.C.3 Synthesis of 2-(2-Chloro-1,1,2-trifluoroethyl)oxolane (178)²⁶⁶

A mixture of oxolane (22.87g, 0.318mol) and chlorotrifluoroethene (17.69g, 0.152mol) was irradiated at a fixed distance from a ⁶⁰Co gamma source. After 4 days (9MRads of radiation) the tube was removed and the excess ether was allowed to evaporate to leave a colourless liquid. Distillation gave 2-(2-chloro-1,1,2-trifluoropropyl)oxolane (**178**)(11.74g, 41%); b.p. 81°C/49mmHg; [Found: C, 38.50; H, 3.78. Calc. for C₆H₈ClF₃O: C, 37.85; H, 3.63%]; NMR spectrum 29; m/z (CI+) 191 (MH⁺, 1.7%), 189 (MH⁺, 0.45%), 71 (M⁺-C₂ClF₃H).

IX.D Halogenation of Fluorinated Ethers

IX.D.1 Synthesis of 1-Chloromethoxy-2,2,3,4,4,4-hexafluorobutane (185)²⁶⁹

A mixture of compound (**173**)(4.67g, 23.9mmol), chlorine (1.65g, 23.2mmol) and carbon disulphide (20ml) was left in sunlight for 12h. The gaseous by-products were allowed to evaporate to leave a colourless liquid. Preparative gas chromatography gave 1-chloromethoxy-2,2,3,4,4,4-hexafluorobutane (**185**)(2.60g, 47.2%); b.p. 35°C/16mmHg; NMR spectrum 30; m/z (EI+) 195 (M⁺-Cl, 40%), 49 (100%).

IX.D.2 Synthesis of 2-Chloro-5-(1,1,2,3,3,3-hexafluoropropyl)oxolane (186)

A mixture of compound (**176**)(5.32g, 24.0mmol), chlorine (1.65g, 23.2mmol) and carbon disulphide (20ml) was left in sunlight for 12h. The gaseous by-products were allowed to evaporate to leave a colourless liquid. Distillation gave 2-chloro-5-(1,1,2,3,3,3-hexafluoropropyl)oxolane (**186**)(5.15g, 83.6%); b.p. 52-54°C/8mmHg; NMR spectrum 31; IR spectrum 25; mass spectrum 24; m/z (EI+) 223 (MH⁺-Cl, 1.6%), 71 (100%).

IX.D.3 Synthesis of 2-Chloro-5-(1,1,3,3,3-pentafluoropropyl)oxolane (187)

A mixture of compound (**177**) (3.19g, 15.6mmol), chlorine (1.65g, 23.2mmol) and carbon disulphide (20ml) was left in sunlight for 12h. The gaseous by-products were allowed to evaporate to leave a colourless liquid. Distillation gave 2-chloro-5-(1,1,3,3,3-pentafluoropropyl)oxolane (**187**)(1.94g, 52.1%); b.p. 68-70°C/12mmHg; NMR spectrum 32; IR spectrum 26; mass spectrum 25; m/z (EI+) 203 (M⁺-Cl, 100%).

IX.D.4 Synthesis of 2-Chloro-5-(2-chloro-1,1,2-trifluoroethyl)oxolane (188)

A mixture of compound (**178**) (4.67g, 23.9mmol), chlorine (1.65g, 23.2mmol) and carbon disulphide (20ml) was left in sunlight for 12h. The gaseous by-products were allowed to evaporate to leave a colourless liquid. Distillation gave 2-chloro-5-(2-chloro-1,1,2-trifluoroethyl)oxolane (**188**)(3.32g, 62.3%); b.p. 76°C/13mmHg; NMR spectrum 33; IR spectrum 27; mass spectrum 26; m/z (EI+) 257 (M⁺-1, 100%).

IX.D.5 The Reaction of 2-Chloro-5-(1,1,2,3,3,3-Hexafluoropropyl)-oxolane (176) and Sodium Hydroxide

A thick walled pyrex tube was charged with 2-chloro-5-(1,1,2,3,3,3-hexafluoropropyl)oxolane (**176**)(910mg, 3.55mmol) and freshly powdered sodium hydroxide (142mg, 3.55mmol), then the tube sealed under vacuum. The tube was then heated to 80°C for 12h. The contents were frozen in liquid air and the tube opened, molecular distillation gave 2-(1,1,2,3,3,3-hexafluoropropyl)-2,3-dihydrofuran (**189**)(0.41g, 52.8%); b.p. 45-47°C/5mmHg; NMR spectrum 33; IR spectrum 27; mass spectrum 26; m/z (EI+) 221 (MH⁺, 100%).

IX.E. The Coupling of Nucleoside Bases to Polyfluorinated α -Haloethers

IX.E.1 Silylation of Pyrimidine Bases²⁷⁴

IX.E.1.a Silylation of Uracil (190)

A mixture of uracil (10.00g, 89.2mmol), hexamethyldisilylzane (50ml) and a catalytic amount of ammonium sulphate (40mg, 0.3mmol) were heated at 160°C for 18h. The excess hexamethyldisilylzane was then distilled off, *in vacuo*, to leave a colourless liquid 1,3-disilyloxypyrimidine (**190**). This was used without further purification.

IX.E.1.b Silylation of 5-Fluorouracil (191)

A mixture of 5-fluorouracil (10.0g, 76.9mmol), hexamethyldisilylzane (50ml) and a catalytic amount of ammonium sulphate (40mg, 0.3mmol) were heated at 160°C for 18h. The excess hexamethyldisilylzane was then distilled off, *in vacuo*, to leave a colourless liquid 5-fluoro-1,3-disilyloxypyrimidine (**191**). This was used without purification for further experiments.

IX.E.2 General Procedure for Coupling of Pyrimidine Bases²⁷⁷

A mixture containing a chlorinated polyfluoroether and a silylated base in dry acetonitrile (20ml) was cooled to -15°C. Trimethylsilyl triflate (1ml) was added dropwise and the reaction monitored by silica TLC with ethyl acetate as the eluent. On completion, the reaction was diluted with dichloromethane (100ml) and quenched with saturated sodium hydrogen carbonate (50ml) and dried over magnesium sulphate. Evaporation of solvent gave a white solid purified by flash silica gel chromatography with ethyl acetate as eluent. All yields are quoted as pure isolated products.

IX.E.2.a Reaction of 2-Chloro-5-(2-chloro-1,1,2-trifluoroethyl)oxolane (188) and 1,3-Disilyloxy pyrimidine (190)

Chlorinated polyfluoroether (**188**)(1.67g, 7.49mmol) and base (**190**)(3.63g, 14.99mmol) gave 2-uradyl-5-(2-chloro-1,1,2-trifluoroethyl)oxolane (192)(1.06g, 47.4%) as a white solid; m.p. 197-199°C; [Found: C, 40.2; H, 3.35; N, 9.4 (MH⁺, 299) C₁₀H₁₀ClF₃N₂O₃ requires C, 40.2; H, 3.4; N, 9.4%]; λ_{max} (CH₃CN) 258nm (log₁₀ε 5.7); NMR spectrum 35; IR spectrum 29; mass spectrum 28.

IX.E.2.b Reaction of 2-Chloro-5-(2-chloro-1,1,2-trifluoroethyl)oxolane (188) and 5-Fluoro-1,3-disilyloxy pyrimidine (191)

Chlorinated polyfluoroether (**188**)(1.14g, 5.11mmol) and base (**191**)(2.60g, 9.99mmol) gave 2-(5-fluorouradyl)-5-(2-chloro-1,1,2-trifluoroethyl)oxolane (193) (0.73g, 45.1%) as a white solid; m.p. 203°C; [Found: C, 39.7; H, 3.0; N, 8.9 (MH⁺, 317) C₁₀H₉ClF₄N₂O₃ requires C, 39.8; H, 3.0; N, 8.85%]; λ_{max} (CH₃CN) 263nm (log₁₀ε 4.8); NMR spectrum 36; IR spectrum 30; mass spectrum 29.

IX.E.2.c Reaction of 2-Chloro-5-(1,1,3,3,3-pentafluoropropyl)oxolane (187) and 1,3-Disilyloxy pyrimidine (190)

Chlorinated polyfluoroether (**187**)(2.27g, 9.51mmol) and base (**190**)(4.66g, 19.24mmol) gave 2-uradyl-5-(1,1,3,3,3-pentafluoropropyl)oxolane (194)(1.56g, 52.2%) as a white solid; m.p. 212°C; [Found: C, 41.95; H, 3.7; N, 8.9 (MH⁺, 315) C₁₁H₁₁F₅N₂O₃ requires C, 42.05; H, 3.5; N, 8.9%]; λ_{max} (CH₃CN) 256nm (log₁₀ε 4.7); NMR spectrum 37; IR spectrum 31; mass spectrum 30.

IX.E.2.d Reaction of 2-Chloro-5-(1,1,3,3,3-pentafluoropropyl)oxolane (187) and 5-Fluoro-1,3-disilyloxy pyrimidine (191)

Chlorinated polyfluoroether (**187**)(1.64g, 6.87mmol) and base (**191**)(3.32g, 12.76mmol) gave 2-(5-fluorouradyl)-5-(1,1,3,3,3-pentafluoropropyl)oxolane (195) (1.12g, 49.1%) as a white solid; m.p. 223-224°C; [Found: C, 39.8; H, 3.05; N, 8.4 (MH⁺, 333) C₁₁H₁₀F₆N₂O₃ requires C, 39.8; H, 3.0; N, 8.4%]; λ_{max} (CH₃CN) 263nm (log₁₀ε 5.5); NMR spectrum 38; IR spectrum 32; mass spectrum 31.

IX.E.2.e Reaction of 2-Chloro-5-(1,1,2,3,3,3-hexafluoropropyl)oxolane (186) and 1,3-Disilyloxy pyrimidine (190)

Chlorinated polyfluoroether (**186**)(0.93g, 3.62mmol) and base (**190**)(1.34g, 5.53mmol) gave 2-uradyl-5-(1,1,2,3,3,3-hexafluoropropyl)oxolane (**196**)(0.87g, 72.3%) as a white solid; m.p. 233-235°C; [Found: C, 39.5; H, 3.2; N, 8.4 (MH⁺, 333) C₁₁H₁₀F₆N₂O₃ requires C, 39.8; H, 3.0; N, 8.4%]; λ_{max} (CH₃CN) 255nm (log₁₀ε 4.3); NMR spectrum 39; IR spectrum 33; mass spectrum 32.

IX.E.2.f Reaction of 2-Chloro-5-(1,1,2,3,3,3-hexafluoropropyl)oxolane (186) and 5-Fluoro-1,3-disilyloxypyrimidine (191)

Chlorinated polyfluoroether (**186**)(0.95g, 3.70mmol) and base (**191**)(1.92g, 7.38mmol) gave 2-(5-fluorouradyl)-5-(1,1,2,3,3,3-hexafluoropropyl)oxolane (**197**)(0.82g, 63.3%) as a white solid; m.p. 242°C; [Found: C, 37.7; H, 2.58; N, 7.2 (MH⁺, 351) C₁₁H₉F₇N₂O₃ requires C, 37.7; H, 2.6; N, 7.1%]; λ_{max} (CH₃CN) 262nm (log₁₀ε 5.2); NMR spectrum 40; IR spectrum 34; mass spectrum 33.

IX.E.2.g Reaction of 1-Chloromethoxy-2,2,3,4,4,4-hexafluorobutane (185) and 1,3-Disilyloxypyrimidine (190)

Chlorinated polyfluoroether (**185**)(1.63g, 7.07mmol) and base (**190**)(3.39g, 14.00mmol) gave 1-uradylmethoxy-2,2,3,4,4,4-hexafluorobutane (**198**)(0.72g, 33.3%) as a white solid; m.p. 187°C; [Found: C, 35.3; H, 2.6; N, 9.15 (MH⁺, 307) C₉H₈F₆N₂O₃ requires C, 35.3; H, 2.6; N 9.3%]; λ_{max} (CH₃OH) 257nm (log₁₀ε 5.1); NMR spectrum 41; IR spectrum 35; mass spectrum 34.

IX.E.2.h Reaction of 1-Chloromethoxy-2,2,3,4,4,4-hexafluorobutane (185) and 5-Fluoro-1,3-disilyloxypyrimidine (191)

Chlorinated polyfluoroether (**185**)(1.16g, 5.03mmol) and base (**191**)(2.63g, 10.11mmol) gave 1-(5-fluorouradyl)methoxy-2,2,3,4,4,4-hexafluorobutane (**199**)(0.41g, 25.1%) as a white solid; m.p. 192°C; [Found: C, 33.4; H, 2.2; N, 8.6 (MH⁺, 325) C₉H₇F₇N₂O₃ requires C, 33.35; H, 2.2; N, 8.6%]; λ_{max} (CH₃OH) 265nm (log₁₀ε 4.9); NMR spectrum 42; IR spectrum 36; mass spectrum 35.

IX.E.3 Reaction of 2-Chloro-5-(1,1,2,3,3,3-hexafluoropropyl)oxolane (186) and 1,3-Disilyloxypyrimidine (190) with Tin (IV) Chloride

To a stirred solution of chlorinated polyfluoroether (**186**)(0.95g, 3.70mmol) and base (**190**)(1.34g, 5.53mmol) in dry dichloromethane (20ml), tin (IV) chloride (7.45mmol) was added. The reaction was stirred for 6 h at -15°C, and then poured on to saturated aqueous sodium hydrogen carbonate. The aqueous layer was extracted with

dichloromethane (3x150ml) and the extracts dried, magnesium sulphate. Evaporation of the solvent and flash column chromatography (eluent ethyl acetate) gave 2-uradyl-5-(1,1,2,3,3,3-hexafluoropropyl)oxolane (**196**)(0.83g, 67.8%) as a white solid; data as IX.E.2.e.

IX.E.4 General Procedure for Coupling Purine Bases

A mixture containing a chlorinated polyfluoroether, a protected purine base and potassium carbonate in dry DMF (100ml) was stirred for 18h. The solvent was then removed *in vacuo*. and the oil was diluted with dichloromethane (100ml) and washed with saturated sodium chloride (50ml) and dried over magnesium sulphate. Evaporation of solvent gave a white solid purified by flash silica gel chromatography with ethyl acetate as eluent. All yields are quoted as pure isolated products.

IX.E.4.a Reaction of 1-Chloromethoxy-2,2,3,4,4,4-hexafluorobutane (185) and 2-Amino-6-chloropurine (144)

Chlorinated polyfluoroether (**185**)(1.37g, 5.94mmol), base (**148**)(1.01g, 5.95mmol) and potassium carbonate (0.92g, 5.90mmol) gave 1-(2-amino-6-chloropurinyl)methoxy-2,2,3,4,4,4-hexafluorobutane (205)(147.0mg, 6.8%) as a white solid; m.p.176°C; [Found: C, 33.3; H, 2.2; N, 19.3 (MH⁺, 364) C₁₀H₈ClF₆N₅O requires C, 33.0; H, 2.2; N, 19.25%]; λ_{max} (CH₃OH) 250, 310nm (log₁₀ε 5.8, 4.1); NMR spectrum 43; IR spectrum 37; mass spectrum 36.

IX.E.4.b Reaction of 2-Chloro-5-(1,1,2,3,3,3-hexafluoropropyl)oxolane (186) and 6-Chloropurine (144)

Chlorinated polyfluoroether (**186**)(2.82g, 10.95mmol), base (**144**)(1.96g, 12.68mmol) and potassium carbonate (1.98g, 12.69mmol) gave 2-(6-chloropurinyl)-5-(1,1,2,3,3,3-hexafluoropropyl)oxolane (206)(0.94g, 22.9%) as a white solid; m.p.244°C; [Found: C, 38.5; H, 2.4; N, 9.7 (M⁺, 374) C₁₂H₉ClF₆N₄O requires C, 38.5; H, 2.4; N, 9.5%]; λ_{max} (CH₃OH) 262nm (log₁₀ε 4.1); NMR spectrum 44; IR spectrum 38; mass spectrum 37.

IX.E.4.c Reaction of 2-Chloro-5-(1,1,2,3,3,3-hexafluoropropyl)oxolane (186) and 2-Amino-6-chloropurine (148)

Chlorinated polyfluoroether (**186**)(0.81g, 3.16mmol), base (**148**)(1.01g, 5.95mmol) and potassium carbonate (0.97g, 6.22mmol) gave 2-(2-amino-6-chloropurinyl)-5-(1,1,2,3,3,3-hexafluoropropyl)oxolane (207)(0.14g, 11.4%) as a

white solid; m.p. 258°C; [Found: C, 37.0; H, 2.8; N, 9.2 (MH⁺, 390) C₁₂H₁₀ClF₆N₅O requires C, 37.0; H, 2.6; N, 9.0%]; λ_{max} (CH₃OH) 250, 307nm (log₁₀ε 5.8, 4.1); NMR spectrum 45; IR spectrum 39; mass spectrum 38.

IX.E.4.d Reaction of 2-Chloro-5-(1,1,3,3,3-pentafluoropropyl)oxolane (187) and 6-Chloropurine (144)

Chlorinated polyfluoroether (**187**)(3.19g, 13.37mmol), base (**144**)(2.03g, 13.13mmol) and potassium carbonate (2.11g, 13.53mmol) gave 2-(6-chloropurinyl)-5-(1,1,3,3,3-pentafluoropropyl)oxolane (208)(0.81g, 17.0%) as a white solid; m.p.254°C; [Found: C, 40.4; H, 2.8; N, 9.9 (MH⁺, 357) C₁₂H₁₀ClF₅N₄O requires C, 40.4; H, 2.8; N,9.9%]; λ_{max} (CH₃OH) 262nm (log₁₀ε 4.1); NMR spectrum 46; IR spectrum 40; mass spectrum 39.

IX.E.4.e Reaction of 2-Chloro-5-(2-chloro-1,1,2-trifluoroethyl)oxolane (188) and 6-Chloropurine (144)

Chlorinated polyfluoroether (**188**)(1.94g, 8.70mmol), base (**144**)(1.92g, 12.42mmol) and potassium carbonate (1.94g, 12.4mmol) gave 2-(6-chloropurinyl)-5-(2-chloro-1,1,2,-trifluoroethyl)oxolane (209)(0.92g, 31.0%) as a white solid; m.p. 237°C; [Found: C, 38.5; H, 2.8; N, 20.9 (M⁺, 341) C₁₁H₉Cl₂F₃N₄O requires C, 38.7; H, 2.7; N, 20.8%]; λ_{max} (CH₃CN) 262nm (log₁₀ε 4.7); NMR spectrum 47; IR spectrum 41; mass spectrum 40.

IX.E.5 Deprotection of 2-Amino-6-chloropurinyl Derivatives

IX.E.5.a To 2-(1,1,2,3,3,3-Hexafluoropropyl)-5-(guanyl)oxolane (210)

A suspension of 2-(2-amino-6-chloropurinyl)-5-(1,1,2,3,3,3-hexafluoropropyl)oxolane (**207**)(0.11g, 0.28mmol) in 2M hydrochloric acid (10ml) and water (100ml) was heated at reflux for 3h. The solution was evaporated to dryness to leave an off-white/yellow solid. The crude material was purified by silica gel chromatography, eluent chloroform-methanol (5:1), to yield 2-(1,1,2,3,3,3-hexafluoropropyl)-5-(guanyl)oxolane (210)(66.9mg, 64.4%); a white solid; m.p.210-211°C, [Found C, 38.9; H, 3.0; N, 18.8 (MH⁺, 372) C₁₂H₁₁F₆N₅O₂ requires C, 38.8; H, 3.0; N, 18.9%]; λ_{max} (CH₃OH) 256nm (log₁₀ε 4.1); NMR spectrum 48; IR spectrum 42; mass spectrum 41.

IX.E.5.b To 1-Guanylmethoxy-2,2,3,4,4,4-hexafluorobutane (211)

1-(6-chloropurinyloxy)methoxy-2,2,3,4,4,4-hexafluorobutane (205)(45.6mg, 0.13mmol) gave 1-guanylmethoxy-2,2,3,4,4,4-hexafluorobutane (211)(36.6mg, 82.0%); a white solid; m.p.210-211°C, [Found C, 35.35; H, 2.8; N, 20.3 (MH⁺, 344) C₁₀H₁₀F₆N₆O requires C, 35.0; H, 2.6; N, 20.4%]; λ_{max} (CH₃OH) 255nm (log₁₀ε 4.4); NMR spectrum 49; IR spectrum 43; mass spectrum 42.

IX.E.6 General Method for the Deprotection of 2-(6-Chloropurinyloxy)-5-polyfluoroalkylethers

A solution of the 6-chloropurinyloxy polyfluoroalkylether in fresh saturated methanolic ammonia solution (30ml) was heated in an autoclave tube for 6h at 100°C. Solvent was removed under reduced pressure and the crude residue purified by silica gel chromatography with chloroform-methanol (5:1) as eluent to yield a white solid. All yields are quoted as pure isolated products.

IX.E.6.a To 2-Adenyl-5-(1,1,2,3,3,3-hexafluoropropyl)oxolane (212)

2-(6-chloropurinyloxy)-5-(2,2,3,4,4,4-hexafluoropropyl)oxolane (206)(90.1mg, 0.24mmol) gave 2-adenyl-5-(2,2,3,4,4,4-hexafluoropropyl)oxolane (212)(72.5mg, 85%); a white solid; m.p.210-211°C, [Found C, 40.9; H, 3.1; N, 20.0 (MH⁺, 356) C₁₂H₁₁F₆N₅O requires C, 40.6; H, 3.1; N, 19.7%]; λ_{max} (CH₃OH) 263nm (log₁₀ε 4.6); NMR spectrum 50; IR spectrum 44; mass spectrum 43.

IX.E.6.b To 2-Adenyl-5-(1,1,3,3,3-pentafluoropropyl)oxolane (213)

2-(6-chloropurinyloxy)-5-(1,1,3,3,3-pentafluoropropyl)oxolane (208)(60.2mg, 0.17mmol) gave 2-adenyl-5-(1,1,3,3,3-pentafluoropropyl)oxolane (213)(45.8mg, 79.9%); a white solid; m.p.210-211°C, [Found C, 42.4; H, 3.4; N, 20.8 (MH⁺, 338) C₁₂H₁₂F₅N₅O requires C, 42.7; H, 3.6; N, 20.8%]; λ_{max} (CH₃OH) 262nm (log₁₀ε 4.8); NMR spectrum 51; IR spectrum 44; mass spectrum 43.

IX.E.6.c To 2-Adenyl-5-(2-chloro-1,1,2-trifluoroethyl)oxolane (214)

2-(6-chloropurinyloxy)-5-(2-chloro-1,1,2-trifluoroethyl)oxolane (209)(89.5mg, 0.26mmol) gave 2-adenyl-5-(2-chloro-1,1,2-trifluoroethyl)oxolane (214)(75.8mg, 90.6%); a white solid; m.p.210-211°C, [Found C, 41.5; H, 3.5; N, 22.0 (MH⁺, 322) C₁₁H₁₁ClF₃N₅O requires C, 41.1; H, 3.45; N, 21.8%]; λ_{max} (CH₃OH) 262nm (log₁₀ε 4.8); NMR spectrum 52; IR spectrum 45; mass spectrum 44.

IX.F The Direct Fluorination of 1-(uradyl)-4-(1,1,1,3,3-pentafluoropropyl)oxolane (194)

Into a solution of 1-(uradyl)-4-(1,1,1,3,3-pentafluoropropyl)oxolane (**194**)(320mg, 0.91mmol) in trifluoroacetic acid (20ml) was bubbled fluorine-nitrogen (1:19)(482mg, 12.6mmol), then nitrogen gas to purge the solution. The mixture was then extracted with chloroform (50ml), 2M sodium hydroxide (5x50ml) and water (100ml). The solvent was removed *in vacuo*. to leave a white solid. Silica gel chromatography with ethyl acetate as the eluent gave 1-(5-fluoro-5,6-dihydro-6-hydroxy-uradyl)-4-(1,1,1,3,3-pentafluoropropyl)oxolane (202)(254mg, 79.7%); a white solid; m.p.240°C, [Found C, 37.9; H, 3.5; N, 7.6 (MH⁺, 351) C₁₁H₁₂F₆N₂O₄ requires C, 37.7; H, 3.5; N, 7.1%]; λ_{max} (CH₃OH) 226nm (log₁₀ε 3.6); NMR spectrum 53; IR spectrum 46; mass spectrum 45

IX.F.1 The Dehydration of 1-(5-fluoro-5,6-dihydro-6-hydroxy-uradyl)-4-(1,1,1,3,3-pentafluoropropyl)oxolane (202)

1-(5-fluoro-5,6-dihydro-6-hydroxy-uradyl)-4-(1,1,1,3,3-pentafluoropropyl)oxolane (**202**)(200mg, 0.57mmol) was heated under dynamic vacuum at 60°C/0.07mmHg for 30 mins. The solid was then run down a silica gel column with ethyl acetate as eluent and gave 2-(5-fluorouradyl)-5-(1,1,3,3,3-pentafluoropropyl)oxolane (195)(178mg, 49.0%) as a white solid; m.p.223-224°C; [Found: C, 39.4; H, 3.2; N, 8.3. C₁₁H₁₀F₆N₂O₃ requires C, 39.8; H, 3.0; N, 8.4%]; data as section IX.E.2.d.

Appendix One

1D NMR Data

- No. 1 3-(Diethoxyphosphinyl)difluoromethylcyclopentene (106)
- No. 2 3-(Diethoxyphosphinyl)difluoromethylcyclohexene (107)
- No. 3 3-(Diethoxyphosphinyl)difluoromethylcycloheptene (108)
- No. 4 (Diethoxyphosphinyl)difluorodeuteromethane (119)
- No. 5 1-Méthyl-(diethoxyphosphinyl)-2,2-difluoroethylbenzene (120)
- No. 6 1-(Diethoxyphosphinyl)difluoromethyl-2,3-epoxycyclohexene (127)
- No. 7 3-(Diethoxyphosphinyl)difluoromethylcyclohexen-6-ol (141)
- No. 8 3-Bromo-6-(diethoxyphosphinyl)difluoromethylcyclohexene (142)
- No. 9 3-[N9-(6-chloropuriny)]-6-(diethoxyphosphinyl)difluoromethyl-
cyclohexene (145)
- No. 10 3-(N9-Adenyl)-6-(diethoxyphosphinyl)difluoromethyl-
cyclohexene (147)
- No. 11 3-(N9-Adenyl)-6-(dihydroxyphosphinyl)difluoromethyl-
cyclohexene (139)
- No. 12 3-[N9-(2-amino-6-chloropuriny)]-6-(diethoxyphosphinyl)difluoro-
methylcyclohexene (149)
- No. 13 3-(Ethoxyhydroxyphosphinyl)difluoromethyl-6-(N9-guanyl)-
cyclohexene (151)
- No. 14 3-(N9-Guanyl)-6-(dihydroxyoxyphosphinyl)difluoromethyl-
cyclohexene (140)
- No. 15 1-Bromo-2-(diethoxyphosphinyl)difluoromethylcyclohexane (153)
- No. 16 [Bis(trimethylsiloxy)phosphinyl]bromodifluoromethane (155)
- No. 17 (Dihydroxyphosphinyl)bromodifluoromethane (154)
- No. 18 1-Bromo-2-(dihydroxyphosphinyl)difluoromethylcyclohexane (156)
- No. 19 1-(Diethoxyphosphinyl)difluoromethyl-2-iodocyclohexane (159)
- No. 20 1-(Diethoxyphosphinyl)difluoromethyl-2-iodocyclopentane (160)
- No. 21 1-(Diethoxyphosphinyl)difluoromethyl-2-iodocycloheptane (161)
- No. 22 3-[(Diethoxyphosphinyl)difluoromethyl]-4-iodooxolane (163)
- No. 23 3-[(Diethoxyphosphinyl)difluoromethyl]-4,5-dihydro-2-iodooxolane or
2-[(diethoxyphosphinyl)difluoromethyl]-4,5-dihydro-3-iodooxolane (164)
- No. 24 Methoxy-2,2,3,4,4,4-hexafluorobutane (173)
- No. 25 Methoxy-2,2,4,4,4-pentafluorobutane (174)
- No. 26 Oligmers based on methoxy-4,4,4-trifluorobutane (175)
- No. 27 2-(1,1,3,3,3-Pentafluoropropyl)oxolane (177)
- No. 28 2-(2-Chloro-1,1,2-trifluoroethyl)oxolane (178)
- No. 29 Chloromethoxy-2,2,3,4,4,4-hexafluorobutane (185)

- No. 30 2-Chloro-5-(1,1,2,3,3,3-hexafluoropropyl)oxolane (186)
No. 31 2-Chloro-5-(1,1,3,3,3-pentafluoropropyl)oxolane (187)
No. 32 2-Chloro-5-(2-chloro-1,1,2-trifluoroethyl)oxolane (188)
No. 33 2-(1,1,2,3,3,3-hexafluoropropyl)-4,5-dihydrofuran (189)
No. 34 2-(2-Chloro-1,1,2-trifluoroethyl)-5-uradyloxolane (192)
No. 35 2-(2-Chloro-1,1,2-trifluoroethyl)-5-(5-fluorouradyl)oxolane (193)
No. 36 2-(1,1,3,3,3-Pentafluoropropyl)-5-uradyloxolane (194)
No. 37 2-(1,1,3,3,3-Pentafluoropropyl)-5-(5-fluorouradyl)oxolane (195)
No. 38 2-(1,1,2,3,3,3-Hexafluoropropyl)-5-uradyloxolane (196)
No. 39 2-(1,1,2,3,3,3-Hexafluoropropyl)-5-(5-fluorouradyl)oxolane (197)
No. 40 Uradylmethoxy-2,2,3,4,4,4-hexafluorobutane (198)
No. 41 5-Fluorouradylmethoxy-2,2,3,4,4,4-hexafluorobutane (199)
No. 42 2-Amino-6-chloropurinylmethoxy-2,2,3,4,4,4-hexafluorobutane (205)
No. 43 2-(6-Chloropurinyl)-5-(1,1,2,3,3,3-hexafluoropropyl)oxolane (206)
No. 44 2-(2-Amino-6-chloropurinyl)-5-(1,1,2,3,3,3-hexafluoropropyl)-oxolane (207)
No. 45 2-(6-Chloropurinyl)-5-(1,1,3,3,3-pentafluoropropyl)oxolane (208)
No. 46 2-(2-Chloro-1,1,2-trifluoroethyl)-5-(6-chloropurinyl)oxolane (209)
No. 47 Guanylmethoxy-1,1,2,3,3,3-hexafluorobutane (210)
No. 48 2-(1,1,2,3,3,3-Hexafluoropropyl)-5-guanyloxolane (211)
No. 49 2-Adenyl-5-(1,1,2,3,3,3-hexafluoropropyl)oxolane (212)
No. 50 2-Adenyl-5-(1,1,3,3,3-pentafluoropropyl)oxolane (213)
No. 51 2-Adenyl-5-(2-chloro-1,1,2-trifluoroethyl)oxolane (214)
No. 52 2-(1,1,3,3,3-Pentafluoropropyl)-5-(5-fluoro-5,6-dihydro-6-hydroxyuradyl)oxolane (202)

All spectra were run in *d*-chloroform unless otherwise stated.

Chemical shifts are quoted in ppm relative to an internal tetramethylsilane reference (^1H and ^{13}C spectra) or an external trichlorofluoromethane reference (^{19}F spectra) with downfield shifts positive.

For an AB system, chemical shifts are quoted as the 'centre of gravity,' calculated from:

$$\delta_1 - \delta_3 = \delta_2 - \delta_4 = \sqrt{(\Delta\nu^2 + J^2)}$$

Where δ_n is the chemical shift of the n th peak, D_n is the difference in chemical shifts between the two resonances of the nuclei and J is the coupling constant.

The following abbreviations are used:

s = singlet

d = doublet

t = triplet

q = quartet

m = multiplet

All ^{13}C nmr and ^{31}P nmr spectra are recorded broad band proton decoupled.

The following spectra were run in d_6 -dimethylsulphoxide 10, 11, 13, 14 and 47 to 51, while d_6 -acetone was used to run spectra 34 to 41.

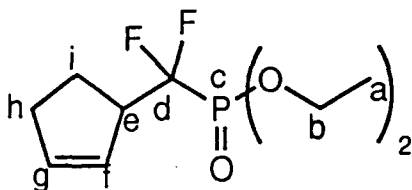
No.1 3-(Diethoxyphosphinyl)difluoromethylcyclopentene (106)

Chemical Shift/p.p.m.	Multiplicity	Coupling Constant/Hz	Relative Intensity	Assignment
<i>¹H</i>				
1.415	t	³ J _{HH} =7.1	6	a
2.084	t	² J _{HH} =9.5	2	i
	d	³ J _{HH} =3.2		
	t	³ J _{HH} =2.1		
2.408	AB	² J _{HH} =12.6	2	h
	d	³ J _{HH} =3.2		
	t	³ J _{HH} =1.3		
3.435	m		1	e
4.299	d	³ J _{HP} =7.3	4	b
	q (5 lines)	³ J _{HH} =7.3		
5.764	m		1	f
6.064	m		1	g
<i>³¹P</i>				
6.824	t	² J _{PF} =113.5	1	c
<i>¹⁹F</i>				
-115.104	AB	² J _{FF} =301.3	1	d
	d	² J _{FP} =113.2		
	d	³ J _{FH} =17.4		
-115.586	AB	² J _{FF} =301.3	1	d
	d	² J _{FP} =113.2		
	d	³ J _{FH} =17.4		

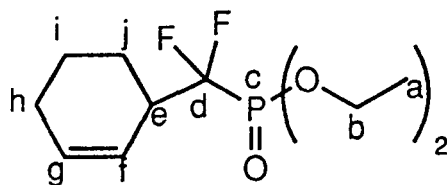
No.2 3-(Diethoxyphosphinyl)difluoromethylcyclohexene (107)

	Chemical Shift/p.p.m.	Multiplicity	Coupling Constant/Hz	Relative Intensity	Assignment
¹ H	1.384	t	³ J _{HH} =6.8	6	a
	1.544	d	³ J _{HH} =7.2	1	h _{axial}
		d	³ J _{HH} =2.8		
	1.702	d	³ J _{HH} =12.8	1	j _{axial}
		d	³ J _{HH} =12.4		
		d	² J _{HH} =12.4		
		d	³ J _{HH} =2.8		
	1.850	m		1	i _{axial}
	1.971	m		1	j _{equatorial}
	2.017 to	m		2	h, i _{equatorial}
	2.039				
	2.913	t	³ J _{HF} =18.8	1	e
		d	³ J _{HH} =12.4		
		d	³ J _{HH} =6.4		
		d	³ J _{HH} =3.2		
4.273	d	³ J _{HP} =6.8	4	b	
	q(5 lines)	³ J _{HH} =6.8			
5.779	AB	³ J _{HH} =9.8	1	g	
5.946	AB	³ J _{HH} =9.8	1	f	
⁻¹³ C	16.293	d	³ J _{CP} =14.8		a
	20.978	t	³ J _{CF} =4.5		j
		d	³ J _{CP} =2.2		
	21.925	s			i
	24.680	s			h
	40.834	t	² J _{CF} =19.1		e
		d	² J _{CP} =15.3		
	64.373	d	² J _{CP} =15.3		b
		d	⁴ J _{CF} =6.8		
	121.442	t	¹ J _{CF} =264.0		d
		d	¹ J _{CP} =211.7		
121.470	t	³ J _{CF} =5.7		f	
	d	³ J _{CP} =4.2			
131.575	s			g	
³¹ P	6.733	t	² J _{PF} =109.3	1	c
	¹⁹ F	-113.274	AB	² J _{FF} =300.0	1
		d	² J _{FP} =110.5		
		d	³ J _{FH} =16.1		
-115.547		AB	² J _{FF} =300.0	1	d
	d	² J _{FP} =109.2			
	d	³ J _{FH} =18.6			

No.3 3-(Diethoxyphosphinyl)difluoromethylcycloheptene (108)

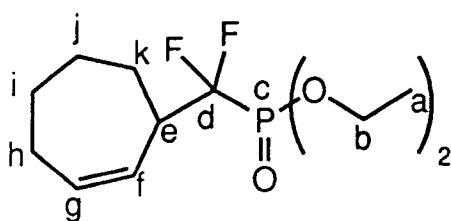

Chemical Shift/p.p.m.	Multiplicity	Coupling Constant/Hz	Relative Intensity	Assignment
¹H				
1.399	t	³ J _{HH} =7.1	6	a
1.251 to 1.900	m		4	h,i,j,k _{axial}
2.000 to 2.260	m		4	h,i,j,k _{equatorial}
3.051	t	³ J _{HF} =20.3	1	e
	d	³ J _{HH} =13.5		
	d	³ J _{HP} =13.5		
4.258	d	³ J _{HP} =7.2	4	b
	q (5 lines)	³ J _{HH} =7.2		
5.900 to 6.010	m		2	f,g
¹³C				
16.293	d	³ J _{CP} =5.2		a
25.782	t	³ J _{CF} =4.1		k
	d	³ J _{CP} =2.2		
26.042	s			j
28.074	s			i
30.351	s			h
45.303	t	² J _{CF} =18.6		e
	d	² J _{CP} =14.5		
64.303	d	² J _{CP} =12.5		b
	d	⁴ J _{CF} =6.2		
121.518	t	¹ J _{CF} =263.1		d
	d	¹ J _{CP} =210.3		
127.791	t	³ J _{CF} =6.2		f
	d	³ J _{CP} =3.2		
133.658	s			g
³¹P				
6.934	t	² J _{PF} =110.5	1	c
¹⁹F				
-109.040	AB	² J _{FF} =298.4	1	d
	d	² J _{FP} =111.0		
	d	³ J _{FH} =17.7		
-109.380	AB	² J _{FF} =298.4	1	d
	d	² J _{FP} =111.8		
	d	³ J _{FH} =21.4		

No.4 (Diethoxyphosphinyl)difluorodeuteromethane (119)

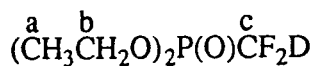

Chemical Shift/p.p.m.	Multiplicity	Coupling Constant/Hz	Relative Intensity	Assignment	
^1H					
	1.399	t	$^3\text{J}_{\text{HH}}=7.1$	6	a
	4.367	d	$^3\text{J}_{\text{HP}}=7.2$	4	b
	q (5 lines)	$^3\text{J}_{\text{HH}}=7.2$			
^{19}F					
	-135.141	d	$^2\text{J}_{\text{FP}}=80.00$	2	c
	d	$^3\text{J}_{\text{FD}}=6.59$			

No.5 1-Methyl-(diethoxyphosphinyl)difluoroethylbenzene (120)

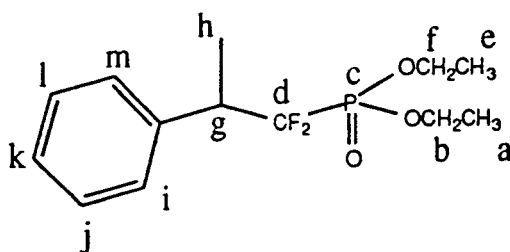

Chemical Shift/p.p.m.	Multiplicity	Coupling Constant/Hz	Relative Intensity	Assignment	
^1H					
	1.095	t	$^3\text{J}_{\text{HH}}=7.3$	3	a or e
	1.234	t	$^3\text{J}_{\text{HH}}=7.3$	3	e or a
	1.479	d	$^3\text{J}_{\text{HH}}=7.2$	3	h
	3.468	m		1	g
	4.367	d	$^3\text{J}_{\text{HP}}=7.3$	2	b or f
	4.367	q (5 lines)	$^3\text{J}_{\text{HH}}=7.3$		
	4.367	d	$^3\text{J}_{\text{HP}}=7.3$	2	f or b
7.163 to 7.389	q (5 lines)	$^3\text{J}_{\text{HH}}=7.3$			
7.163 to 7.389	m		5	i, j, k, l, m	
^{31}P					
6.859	t	$^2\text{J}_{\text{PF}}=106.5$	1	c	
^{19}F					
	-113.663	AB	$^2\text{J}_{\text{FF}}=299.4$	1	d
		d	$^2\text{J}_{\text{FP}}=109.9$		
		d	$^3\text{J}_{\text{FH}}=16.0$		
-115.463	AB	$^2\text{J}_{\text{FF}}=299.4$	1	d	
	d	$^2\text{J}_{\text{FP}}=106.1$			
	d	$^3\text{J}_{\text{FH}}=19.5$			

No.6 1-(Diethoxyphosphinyl)difluoromethyl-2,3-epoxycyclohexene (127)

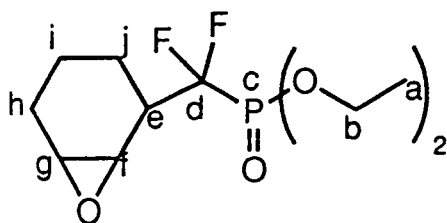

Chemical Shift/p.p.m.	Multiplicity	Coupling Constant/Hz	Relative Intensity	Assignment
¹H				
1.325	t	³ J _{HH} =7.2	6	a
1.199 to 1.288	m		1	h or i _{axial}
1.401 to 1.500	m		4	h or i _{axial}
1.651	m		1	i _{equatorial}
1.737	m		1	J _{axial}
2.053	m		1	J _{equatorial}
2.501	t	³ J _{HF} =19.2	1	e
	d	³ J _{HP} =17.2		
	d	³ J _{HH} =6.0		
	d	³ J _{HH} =6.0		
3.135	d	³ J _{HH} =4.0	1	f
	t	³ J _{HF} =1.6		
3.357	d	³ J _{HH} =4.0	1	g
	m			
4.228	d	³ J _{HP} =7.2	4	b
	q (5 lines)	³ J _{HH} =7.2		
¹³C				
16.413	d	³ J _{CP} =5.7		a
16.518	s			i
20.471	t	³ J _{CF} =4.9		j
	d	³ J _{CP} =1.9		
24.233	s			h
40.709	t	² J _{CF} =19.1		e
	d	² J _{CP} =14.5		
50.241	t	³ J _{CF} =8.3		f
	d	³ J _{CP} =5.3		
64.636	d	² J _{CP} =13.3		b
	d	⁴ J _{CF} =6.8		
120.983	t	¹ J _{CF} =263.5		d
	d	¹ J _{CP} =211.7		
³¹P				
6.910	t	² J _{PF} =109.8	1	c
¹⁹F				
-113.389	AB	² J _{FF} =306.0	1	d
	d	² J _{FP} =108.3		
	d	³ J _{FH} =18.1		
-117.193	AB	² J _{FF} =306.0	1	d
	d	² J _{FP} =110.4		
	d	³ J _{FH} =14.1		

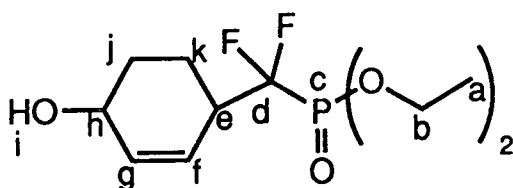
No.7 3-(Diethoxyphosphinyldifluoromethyl)cyclohexen-6-ol (141)

Chemical Shift/p.p.m.	Multiplicity	Coupling Constant/Hz	Relative Intensity	Assignment
¹ H				
1.331	t	³ J _{HH} =7.2	6	a
1.500 to 2.320	m		4	j,k
3.012	m		1	e
4.232	d	³ J _{HP} =7.2	4	b
	q (5 lines)	³ J _{HH} =7.2		
4.422	br m		2	h,i
5.744	AB	³ J _{HH} =11.3	2	g
5.828	AB	³ J _{HH} =9.5	2	f
	m			

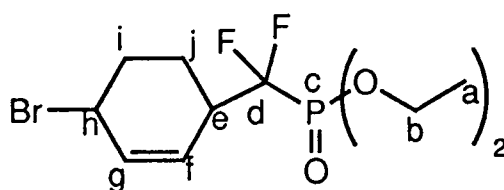
No.8 3-Bromo-6-(diethoxyphosphinyl)difluoromethylcyclohexene major isomer (142)

Chemical Shift/p.p.m.	Multiplicity	Coupling Constant/Hz	Relative Intensity	Assignment
¹H				
1.398	t	³ J _{HH} =7.0	6	a
1.928 to 2.041	m		2	i _{axial} , j _{axial}
2.071 to 3.020	m		2	i _{equatorial} , j _{equatorial}
3.020	m		1	e
4.295	d	³ J _{HP} =7.3	4	b
	q (5 lines)	³ J _{HH} =7.3		
4.496	br m		1	h
5.942	AB	³ J _{HH} =10.4	1	g
6.122	AB	³ J _{HH} =10.4	1	f
	t	³ J _{HF} =3.7		
¹³C				
16.434	d	³ J _{CP} =5.2		a
19.879	m			j
31.090	s			i
41.240	t	² J _{CF} =20.7		e
	d	² J _{CP} =15.5		
46.160	s			h
64.650	d	³ J _{CP} =11.4		b
	d	³ J _{CF} =7.3		
118.312	t	¹ J _{CF} =271.2		d
	d	¹ J _{CP} =203.4		
125.012	t	³ J _{CF} =7.2		f
	d	³ J _{CP} =4.2		
131.819	s			g
³¹P				
6.518	t	² J _{PF} =109.2	1	c
¹⁹F				
-114.625	AB	² J _{FF} =302.5	1	d
	d	² J _{FP} =109.2		
	d	³ J _{FH} =12.9		
-116.087	AB	² J _{FF} =302.5	1	d
	d	² J _{FP} =104.5		
	d	³ J _{FH} =18.6		

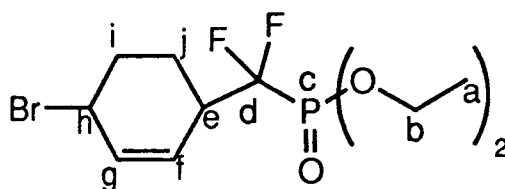
No.8 3-Bromo-6-(diethoxyphosphinyldifluoromethyl)cyclohexene minor isomer (142)

Chemical Shift/p.p.m.	Multiplicity	Coupling Constant/Hz	Relative Intensity	Assignment
¹H				
1.398	t	³ J _{HH} =7.0	6	a
1.928 to 2.041	m		2	i _{axial} , j _{axial}
2.071 to 3.020	m		2	i _{equatorial} , j _{equatorial}
3.020	m		1	e
4.295	d	³ J _{HP} =7.3	4	b
4.765	q (5 lines)	³ J _{HH} =7.3		
4.765	br m		1	h
5.942	AB	³ J _{HH} =10.4	1	g
6.122	d	³ J _{HH} =3.4		
6.122	AB	³ J _{HH} =10.4	1	f
	t	³ J _{HH} =3.1		
³¹P				
6.538	t	² J _{PP} =89.2	1	c
¹⁹F				
-113.963	AB	² J _{FF} =302.8	1	d
	d	² J _{FP} =87.3		
	d	³ J _{FH} =19.1		
-114.795	AB	² J _{FF} =302.8	1	d
	d	² J _{FP} =87.3		
	d	³ J _{FH} =16.9		

No.9 3-[N9-(6-chloropuriny)]-6-(diethoxyphosphiny)difluoromethyl-
cyclohexene (145b)

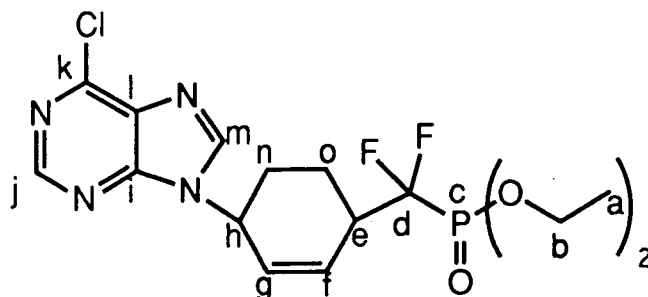

	Chemical Shift/p.p.m.	Multiplicity	Coupling Constant/Hz	Relative Intensity	Assignment
1H	1.429	t	$^3J_{HH}=6.8$	6	a
	1.923	d	$^3J_{HP}=2.4$	1	Oaxial
		d	$^3J_{HF}=0.4$		
		d	$^2J_{HH}=13.6$		
		d	$^3J_{HH}=13.6$		
	2.044	d	$^3J_{HH}=9.6$	1	Paxial
		d	$^3J_{HH}=2.8$		
		d	$^2J_{HH}=12.8$		
		d	$^3J_{HH}=12.8$		
	2.227	m	$^3J_{HH}=10.8$	1	Oequatorial
		m	$^3J_{HH}=2.4$		
	2.497	m		1	Pequatorial
	3.197	m		1	e
	4.295	d	$^3J_{HP}=6.8$	4	b
		q (5 lines)	$^3J_{HH}=6.8$		
5.430	br m		1	h	
6.043	AB	$^3J_{HH}=10.4$	1	f	
6.349	AB	$^3J_{HH}=10.4$	1	g	
8.170	s		1	m	
8.767	s		1	j	
^{13}C	16.408	d	$^3J_{CP}=5.2$		a
	20.526	m			o
	29.342	s			n
	40.527	t	$^2J_{CF}=20.7$		e
		d	$^2J_{CP}=15.6$		
	51.177	s			h
	64.768	d	$^3J_{CP}=13.5$		b
		d	$^3J_{CF}=6.2$		
	120.751	t	$^1J_{CF}=284.4$		d
		d	$^1J_{CP}=227.1$		
	128.463	m			f
	128.722	s			g
	143.299	s			i
	143.819	s			k
	151.168	s			m
151.413	s			j	
151.902	s			l	

^{31}P	5.876	t	$^2\text{J}_{\text{PF}}=107.9$	1	c
^{19}F	-114.280	AB	$^2\text{J}_{\text{FF}}=301.8$	1	d
		d	$^2\text{J}_{\text{FP}}=107.6$		
		d	$^3\text{J}_{\text{FH}}=15.8$		
	-115.507	AB	$^2\text{J}_{\text{FF}}=301.8$	1	d
		d	$^2\text{J}_{\text{FP}}=105.7$		
		d	$^3\text{J}_{\text{FH}}=17.3$		

No.9 3-[N9-(6-chloropurinyl)]-6-(diethoxyphosphinyl)difluoromethyl-
cyclohexene (145a)

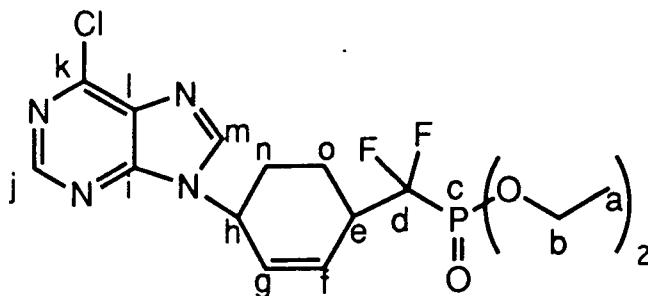

	Chemical Shift/p.p.m.	Multiplicity	Coupling Constant/Hz	Relative Intensity	Assignment
1H	1.403	t	$^3J_{HH}=7.2$	6	a
		d	$^3J_{HP}=1.6$		
		d	$^3J_{HF}=0.4$		
	1.770	d	$^2J_{HH}=14.0$	1	Oaxial
		d	$^3J_{HH}=14.0$		
		d	$^3J_{HH}=12.0$		
		d	$^3J_{HH}=3.6$		
	2.013	m		1	η axial
	2.120	m		1	Oequatorial
	2.175	m		1	η equatorial
	3.082	m		1	e
	4.317	d	$^3J_{HP}=7.2$	4	b
		q (5 lines)	$^3J_{HH}=7.2$		
	5.430	br·m		1	h
6.135	AB	$^3J_{HH}=10.4$	1	f	
	d	$^3J_{HH}=2.8$			
6.349	AB	$^3J_{HH}=10.0$	1	g	
8.319	s		1	m	
8.767	s		1	j	
^{13}C	16.439	d	$^3J_{CP}=5.3$		a
	17.041	m			o
	27.373	s			n
	40.931	t	$^2J_{CF}=20.2$		e
		d	$^2J_{CP}=15.7$		
	48.393	s			h
	64.885	d	$^3J_{CP}=14.5$		b
		d	$^3J_{CF}=6.8$		
	120.678	t	$^1J_{CF}=264.4$		d
		d	$^1J_{CP}=211.3$		
	126.121	s			g
	130.657	t	$^3J_{CF}=8.8$		f
		d			
	132.155	s			k
	144.770	s			i
151.070	s			m	
151.760	s			j	
151.764	s			l	

^{19}F	6.045	t	$^2J_{\text{PF}}=106.1$	1	c
	-111.419	AB	$^2J_{\text{FF}}=297.6$	1	d
		d	$^2J_{\text{FP}}=112.5$		
	-113.152	AB	$^2J_{\text{FF}}=297.6$	1	d
		d	$^2J_{\text{FP}}=111.6$		

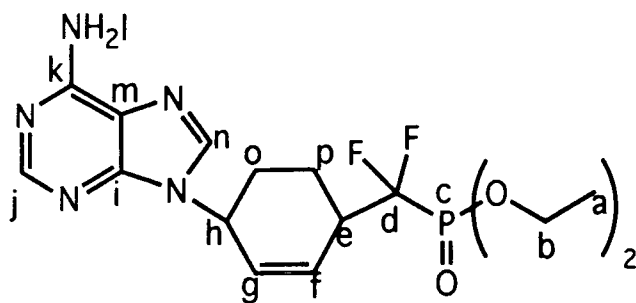
No.10 3-(N9-Adenyl)-6-(diethoxyphosphinyl)difluoromethylcyclohexene (147)

Chemical Shift/p.p.m.	Multiplicity	Coupling Constant/Hz	Relative Intensity	Assignment
<i>¹H</i>				
1.317	t	³ J _{HH} =7.0	6	a
1.883	m		2	o, P axial
2.080	m		1	o or P equatorial
2.348	m		1	o or P equatorial
3.097	m		1	e
4.228	d	³ J _{HP} =7.3	4	b
	q (5 lines)	³ J _{HH} =7.3		
5.179	m		1	h
5.944	AB	³ J _{HH} =10.5	1	f
6.181	AB	³ J _{HH} =10.5	1	g
6.308	br s (D ₂ O ex)		2	l
7.753	s		0.5	j or n
7.688	s		0.5	j or n
8.184	s		1	j or n
<i>³¹P</i>				
6.319	t	² J _{PF} =109.3	1	c
<i>¹⁹F</i>				
-115.114	AB	² J _{FF} =309.7	1	d
	d	² J _{FP} =107.3		
-116.639	AB	² J _{FF} =309.7	1	d
	d	² J _{FP} =107.3		

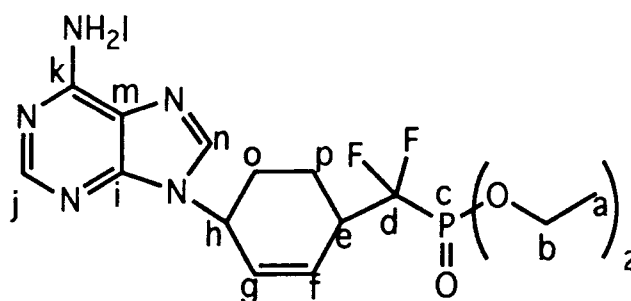
No.10 3-(N9-Adenyl)-6-(diethoxyphosphinyl)difluoromethylcyclohexene (147)

Chemical Shift/p.p.m.	Multiplicity	Coupling Constant/Hz	Relative Intensity	Assignment
<i>¹H</i>				
1.328	t	$^3J_{HH}=6.8$	6	a
1.699	m		1	o or Paxial
1.883	m		1	o or Paxial
2.080	m		2	o, Pequatorial
3.097	m		1	e
4.240	d	$^3J_{HP}=6.5$	4	b
	q (5 lines)	$^3J_{HH}=6.5$		
5.179	m		1	h
6.023	AB	$^3J_{HH}=9.6$	1	f
6.283	AB	$^3J_{HH}=9.6$	1	g
6.308	br s(D ₂ O ex)		2	l
7.821	s		0.5	j or n
7.894	s		0.5	j or n
8.314	s		1	j or n
<i>³¹P</i>				
6.319	t	$^2J_{PF}=112.3$	1	c
<i>¹⁹F</i>				
-112.658	AB	$^2J_{FF}=302.2$	1	d
	d	$^2J_{FP}=112.5$		
-116.639	AB	$^2J_{FF}=302.2$	1	d
	d	$^2J_{FP}=112.5$		

No.11 3-(N⁹-Adenyl)-6-(dihydroxyoxyphosphinyl)difluoromethylcyclohexene
(139)

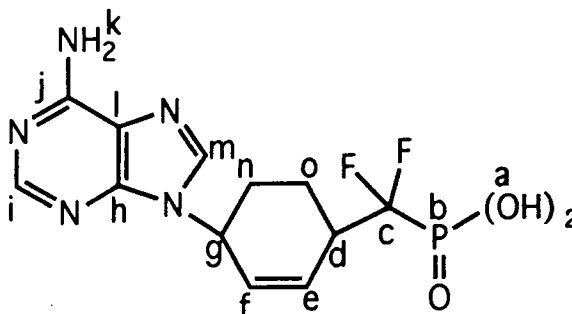

Chemical Shift/p.p.m.	Multiplicity	Coupling Constant/Hz	Relative Intensity	Assignment
<i>¹H</i>				
1.739	m		1	n Or Oaxial
1.910	d	$^2J_{HH}=11.6$	1	n Or Oaxial
	d	$^3J_{HH}=11.6$		
	d	$^3J_{HH}=1.9$		
2.050	m		1	n Or Oequatorial
2.170	m		1	n Or Oequatorial
2.975	m		1	d
3.671	br s(D ₂ O ex)		2	a
5.099	m		1	g
5.778	AB	$^3J_{HH}=10.4$	1	e
6.249	AB	$^3J_{HH}=10.0$	1	f
6.870	br s(D ₂ O ex)		2	k
7.959	s		0.5	l or n
8.001	s		0.5	l or n
8.026	s		1	l or n
<i>³¹P</i>				
1.446	t	$^2J_{PF}=90.2$	1	b
<i>¹⁹F</i>				
-114.679	AB	$^2J_{FF}=281.4$	1	c
	d	$^2J_{FP}=87.3$		
	d	$^3J_{FH}=17.7$		
-115.878	AB	$^2J_{FF}=281.4$	1	c
	d	$^2J_{FP}=87.7$		
	d	$^3J_{FH}=16.2$		

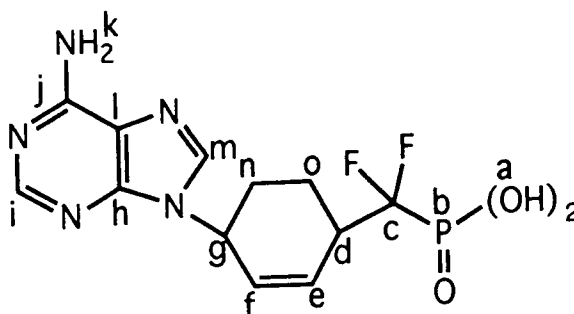
No.11 3-(N 9-Adenyl)-6-(dihydroxyoxyphosphinyl)difluoromethylcyclohexene (139)

Chemical Shift/p.p.m.	Multiplicity	Coupling Constant/Hz	Relative Intensity	Assignment
<i>¹H</i>				
1.739	m		1	n or O _{axial}
1.910	d	² J _{HH} =11.6	1	n or O _{axial}
	d	³ J _{HH} =11.6		
	d	³ J _{HH} =1.9		
2.050	m		1	n or O _{equatorial}
2.170	m		1	n or O _{equatorial}
2.975	m		1	d
3.671	br s(D ₂ O ex)		2	a
5.044	m		1	g
5.953	AB	³ J _{HH} =10.4	1	e
	m			
6.408	AB	³ J _{HH} =10.4	1	f
6.870	br s(D ₂ O ex)		2	k
7.878	s		1	i or m
8.043	s		0.5	i or m
8.094	s		0.5	i or m
<i>³¹P</i>				
1.446	t	² J _{PF} =90.2	1	b
<i>¹⁹F</i>				
-110.710	AB	² J _{FF} =276.9	1	c
	d	² J _{FP} =92.6		
-112.967	AB	² J _{FF} =277.7	1	c
	d	² J _{FP} =92.6		

No.12 3-[N9-(2-amino-6-chloropuriny)]-6-(diethoxyphosphiny)difluoromethyl-
cyclohexene (149)

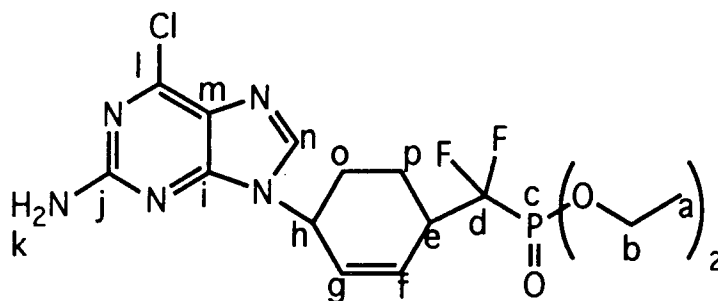

	Chemical Shift/p.p.m.	Multiplicity	Coupling Constant/Hz	Relative Intensity	Assignment
^1H	1.392	t	$^3J_{\text{HH}}=7.2$	6	a
	1.819	m		1	Oaxial
	2.018	m		1	Paxial
	2.157	m		1	O Or Pequatorial
	2.425	m		1	O Or Pequatorial
	3.241	m		1	e
	4.312	d	$^3J_{\text{HP}}=7.2$	4	b
		q (5 lines)	$^3J_{\text{HH}}=7.2$		
	5.169	m		1	h
	5.332	br s(D ₂ O ex)		2	k
	5.987	AB	$^3J_{\text{HH}}=10.1$	1	f
	6.281	AB	$^3J_{\text{HH}}=10.1$	1	g
	7.792	s		1	n
	^{13}C	16.362	d	$^3J_{\text{CP}}=5.2$	
20.495		m			p
29.067		s			o
40.612		t	$^2J_{\text{CF}}=20.7$		e
		d	$^2J_{\text{CP}}=15.5$		
50.230		s			h
64.764		d	$^3J_{\text{CP}}=13.5$		b
		d	$^3J_{\text{CF}}=6.2$		
122.000		t	$^1J_{\text{CF}}=288.2$		d
		d	$^1J_{\text{CP}}=237.3$		
126.614		m			f
129.318		s			g
140.259		s			n
140.776		s			m
151.260		s			i
153.369		s			j
158.976		s			l
^{31}P	3.524	t	$^2J_{\text{PF}}=94.3$	1	c
^{19}F	-114.693	AB	$^2J_{\text{FF}}=245.2$	1	d
		d	$^2J_{\text{FP}}=93.4$		
		d	$^3J_{\text{FH}}=16.2$		
	-115.083	AB	$^2J_{\text{FF}}=314.7$	1	d
	d	$^2J_{\text{FP}}=91.8$			

d $^3J_{FH}=16.0$

No.12 3-[N9-(2-amino-6-chloropurinyl)]-6-(diethoxyphosphinyl)difluoromethyl-
cyclohexene (149)

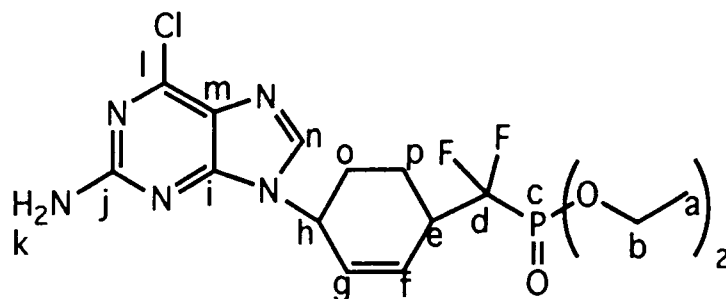

	Chemical Shift/p.p.m.	Multiplicity	Coupling Constant/Hz	Relative Intensity	Assignment
1H	1.402	t	$^3J_{HH}=7.2$	6	a
	1.819	m		1	Oaxial
	2.018	m		1	Paxial
	2.157	m		1	O Or Pequatorial
	2.425	m		1	O Or Pequatorial
	3.307	m		1	e
	4.312	d	$^3J_{HP}=7.2$	4	b
		q (5 lines)	$^3J_{HH}=7.2$		
	5.100	m		1	h
	5.332	br s(D ₂ O ex)		2	k
	6.075	AB	$^3J_{HH}=12.15$	1	f
		m			
	6.430	AB	$^3J_{HH}=10.1$	1	g
	7.920	s		1	n
	^{13}C	15.219	m		
17.027		m			p
27.142		s			o
40.550		t	$^2J_{CF}=20.7$		e
		d	$^2J_{CP}=15.5$		
47.647		s			h
64.764		d	$^3J_{CP}=13.5$		b
		d	$^3J_{CF}=6.2$		
122.000		t	$^1J_{CF}=288.2$		d
		d	$^1J_{CP}=237.3$		
127.605		m			f
129.807		s			g
140.776		s			m
141.695		s			n
151.260		s			i
153.201		s			j
158.976		s			l
^{31}P	3.310	t	$^2J_{PF}=92.4$	1	c
^{19}F	-115.669	AB	$^2J_{FF}=291.1$	1	d
		d	$^2J_{FP}=92.7$		
		d	$^3J_{FH}=16.5$		
-117.060	AB	$^2J_{FF}=291.1$	1	d	

d ${}^2J_{FP}=93.0$
d ${}^3J_{FH}=17.7$

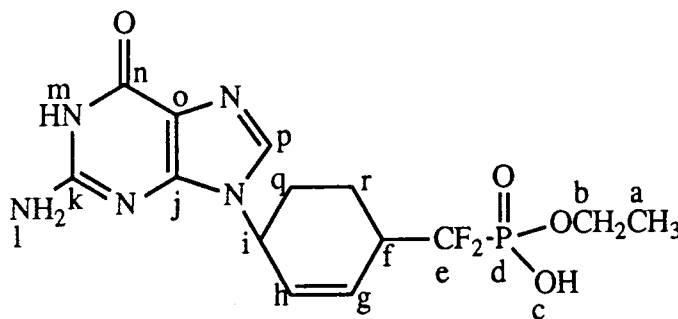
No.13 3-(Ethoxyhydroxyphosphinyl)difluoromethyl-6-(N 9-guanyl)cyclohexene (151)

Chemical Shift/p.p.m.	Multiplicity	Coupling Constant/Hz	Relative Intensity	Assignment
<i>¹H</i>				
1.562	t	$^3J_{HH}=7.2$	3	a
2.126	m		1	q _{axial}
2.344	m		1	r _{axial}
2.370	m		1	q Or r _{equatorial}
2.584	m		1	q Or r _{equatorial}
3.419	m		1	f
4.312	d	$^3J_{HP}=7.2$	2	b
	q (5 lines)	$^3J_{HH}=7.2$		
4.820	br s(D ₂ O ex)		1	c
5.360	m		1	i
6.285	AB	$^3J_{HH}=10.0$	1	g
6.689	AB	$^3J_{HH}=10.2$	1	h
7.635	br s(D ₂ O ex)		2	l
9.105	s		1	p
9.868	br s(D ₂ O ex)		1	m
<i>³¹P</i>				
4.562	t	$^2J_{FP}=92.4$		d
<i>¹⁹F</i>				
-110.684	AB	$^2J_{FF}=305.9$	1	e
	d	$^2J_{FP}=93.7$		
-114.773	AB	$^2J_{FF}=305.9$	1	e
	d	$^2J_{FP}=90.0$		

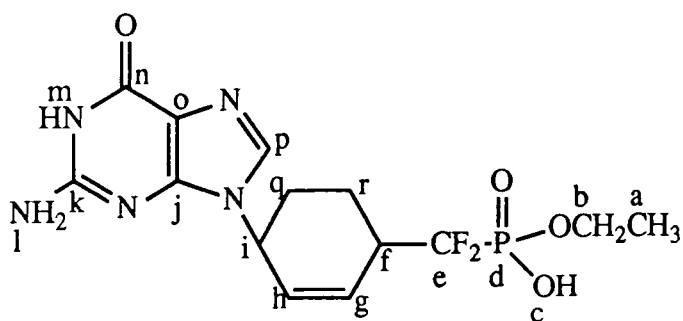
No.13 3-(Ethoxyhydroxyphosphinyl)difluoromethyl-6-(N 9-guanyl)cyclohexene(151)

Chemical Shift/p.p.m.	Multiplicity	Coupling Constant/Hz	Relative Intensity	Assignment
<i>¹H</i>				
1.535	t	³ J _{HH} =6.8	3	a
2.126	m		1	q _{axial}
2.344	m		1	r _{axial}
2.370	m		1	q or r _{equatorial}
2.584	m		1	q or r _{equatorial}
3.419	m		1	f
4.312	d	³ J _{HP} =7.2	2	b
	q (5 lines)	³ J _{HH} =7.2		
4.820	br s(D ₂ O ex)		1	c
5.430	m		1	i
6.382	m		1	g
6.689	AB	³ J _{HH} =10.2	1	h
7.635	br s(D ₂ O ex)		2	l
9.048	s		1	p
9.752	br s(D ₂ O ex)		1	m
<i>³¹P</i>				
4.526	t	² J _{FP} =92.4		d
<i>¹⁹F</i>				
-111.282	AB	² J _{FF} =235.3	1	e
	d	² J _{FP} =93.7		
-111.818	AB	² J _{FF} =229.9	1	e
	d	² J _{FP} =93.7		

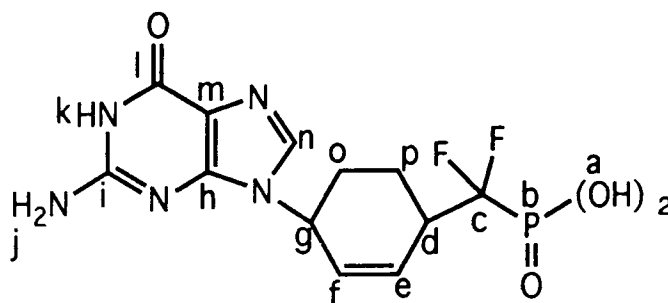
No.14 3-(N 9-Guanyl)-6-(dihydroxyoxyphosphinyl)difluoromethylcyclohexene (140)

Chemical Shift/p.p.m.	Multiplicity	Coupling Constant/Hz	Relative Intensity	Assignment
<i>¹H</i>				
1.755	m		1	o or p axial
1.915	m		1	p or o axial
2.029	m		1	Pequatorial
2.225	m		1	Oequatorial
3.055	m		1	d
4.441	br s		2	a (D ₂ O ex)
5.042	m		1	g
5.866	AB	³ J _{HH} =10.0	1	e
6.189	AB	³ J _{HH} =10.8	1	f
7.219	br s		2	m (D ₂ O ex)
8.783	s		1	n
11.623	br s		1	k (D ₂ O ex)
<i>³¹P</i>				
1.447	t	² J _{FP} =90.2		b
<i>¹⁹F</i>				
-113.441	AB	² J _{FF} =288.5	1	c
	d	² J _{FP} =93.3		
	d	³ J _{FH} =16.6		
-114.835	AB	² J _{FF} =287.8	1	c
	d	² J _{FP} =92.9		
	d	³ J _{FH} =17.3		

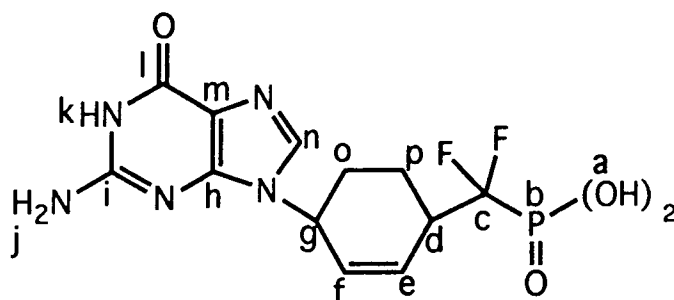
No.14 3-(N 9-Guanyl)-6-(dihydroxyoxyphosphinyl)difluoromethylcyclohexene (140)

Chemical Shift/p.p.m.	Multiplicity	Coupling Constant/Hz	Relative Intensity	Assignment
<i>¹H</i>				
1.755	m		1	o or P axial
1.915	m		1	p or O axial
2.029	m		1	Pequatorial
2.225	m		1	Oequatorial
2.900	m		1	d
4.441	br s		2	a (D ₂ O ex)
4.988	m		1	g
5.940	AB	³ J _{HH} =10.8	1	e
	m			
6.331	AB	³ J _{HH} =10.4	1	f
7.281	br s		2	m (D ₂ O ex)
8.793	s		1	n
11.733	br s		1	k (D ₂ O ex)
<i>³¹P</i>				
1.437	t	² J _{FP} =90.2		b
<i>¹⁹F</i>				
-109.674	AB	² J _{FF} =287.1	1	c
	d	² J _{FP} =91.4		
	d	³ J _{FH} =16.6		
-110.725	AB	² J _{FF} =287.8	1	c
	d	² J _{FP} =90.3		
	d	³ J _{FH} =14.3		

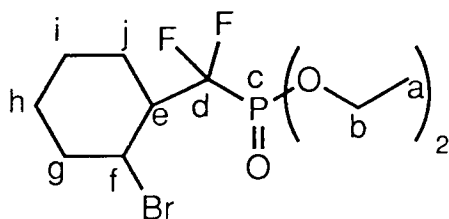
No.15 1-Bromo-2-(diethoxyphosphinyl)difluoromethylcyclohexane (153)

Chemical Shift/p.p.m.	Multiplicity	Coupling Constant/Hz	Relative Intensity	Assignment
<i>¹H</i>				
1.416	m		6	a
1.519 to 2.269	m		8	g,h,i,j
3.221	m		1	e
4.364	m		4	b
4.639	m		1	f
<i>³¹P</i>				
6.334	t	$^2J_{PF}=110.0$		c
<i>¹⁹F</i>				
-104.453	AB	$^2J_{FF}=302.2$	1	d
	d	$^2J_{FP}=110.7$		
	d	$^3J_{FH}=26.4$		
-106.657	AB	$^2J_{FF}=302.0$	1	d
	d	$^2J_{FP}=110.7$		
	d	$^3J_{FH}=21.6$		
-113.777	AB	$^2J_{FF}=300.0$	1	d
	d	$^2J_{FP}=110.0$		
	d	$^3J_{FH}=19.8$		
-115.149	AB	$^2J_{FF}=304.1$	1	d
	d	$^2J_{FP}=110.1$		
	d	$^3J_{FH}=21.6$		

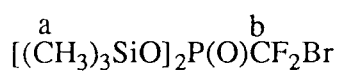
No. 16 [Bis(trimethylsilyloxy)phosphinyl]bromodifluoromethane (155)

	Chemical Shift/p.p.m.	Multiplicity	Coupling Constant/Hz	Relative Intensity	Assignment
^1H	0.17	s		9	a
^{19}F	-57.45	d	$^2J_{\text{FP}}=87.0$	2	b

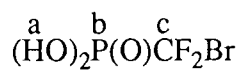
No. 17 (Dihydroxyphosphinyl)bromodifluoromethane (154)

	Chemical Shift/p.p.m.	Multiplicity	Coupling Constant/Hz	Relative Intensity	Assignment
^1H	4.74	br s (D ₂ O ex)		2	a
^{19}F	-62.261	d	$^2J_{\text{FP}}=95.1$	2	c

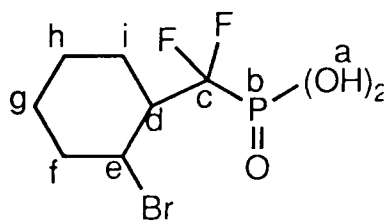
No. 18 1-Bromo-2-(difluorophosphinyl)difluoromethylcyclohexane (156)

Chemical Shift/p.p.m.	Multiplicity	Coupling Constant/Hz	Relative Intensity	Assignment
1H				
1.251 to 2.183	m		8	f,g,h,i
3.392	m		1	d
4.746	m		1	e
^{31}P				
1.003	t	$^2J_{PF}=111.8$		b
^{19}F				
-116.746	d	$^2J_{FP}=112.5$		c
	d	$^3J_{FH}=13.4$		

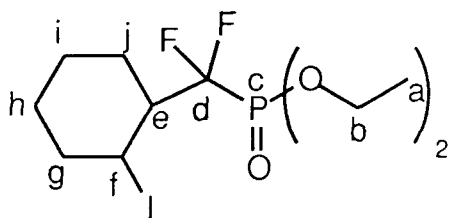
No.19 1-[(diethoxyphosphinyl)difluoromethyl]-2-iodocyclohexane (159)

Chemical Shift/p.p.m.	Multiplicity	Coupling Constant/Hz	Relative Intensity	Assignment
<i>¹H</i>				
1.404	m		6	a
1.806 to 2.322	m		8	g,h,i,j
3.101	m		1	e
4.323	m		4	b
5.085	m		1	f
<i>³¹P</i>				
6.564	t	$^2J_{PF}=108.7$		c
<i>¹⁹F</i>				
-104.261	AB	$^2J_{FF}=303.8$	1	d
	d	$^2J_{FP}=109.9$		
	d	$^3J_{FH}=11.3$		
-106.335	AB	$^2J_{FF}=301.0$	1	d
	d	$^2J_{FP}=106.1$		
	d	$^3J_{FH}=19.1$		
-113.527	AB	$^2J_{FF}=304.5$	1	d
	d	$^2J_{FP}=109.8$		
	d	$^3J_{FH}=19.6$		
-115.475	AB	$^2J_{FF}=305.3$	1	d
	d	$^2J_{FP}=102.9$		

No. 20 1-(Diethoxyphosphinyl)difluoromethyl-2-iodocyclopentane (160)

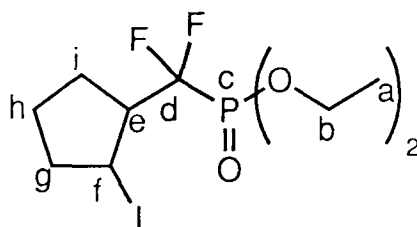

Chemical Shift/p.p.m.	Multiplicity	Coupling Constant/Hz	Relative Intensity	Assignment
1H				
1.347	t	$^3J_{HH}=7.0$	6	a
1.520 to 2.238	m		6	g,h,i
3.010	m		1	e
4.119	d	$^3J_{HP}=7.0$	4	b
	q(5 lines)	$^3J_{HH}=7.0$		
4.574	m		1	f
^{31}P				
6.338	t	$^2J_{PF}=108.5$		c
^{19}F				
-118.066	AB	$^2J_{FF}=301.2$	1	d
	d	$^2J_{FP}=109.7$		
	d	$^3J_{FH}=15.3$		
-121.804	AB	$^2J_{FF}=301.2$	1	d
	d	$^2J_{FP}=108.3$		
	d	$^3J_{FH}=20.7$		

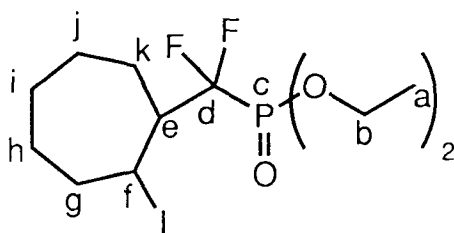
No. 21 1-(Diethoxyphosphinyl)difluoromethyl-2-iodocycloheptane (161)

	Chemical Shift/p.p.m.	Multiplicity	Coupling Constant/Hz	Relative Intensity	Assignment
1H	1.473	t	$^3J_{HH}=7.0$	6	a
	1.527 to 2.351	m		10	g,h,i,j and k
	3.203	m		1	e
	4.416	m		4	b
	6.133	m		1	f
^{31}P	6.910	t	$^2J_{PF}=109.8$		c
^{19}F	-110.376	AB	$^2J_{FF}=301.0$	1	d
		d	$^2J_{FP}=104.7$		
		d	$^3J_{FH}=14.4$		
	-115.480	AB	$^2J_{FF}=301.3$	1	d
		d	$^2J_{FP}=105.9$		
		d	$^3J_{FH}=19.3$		

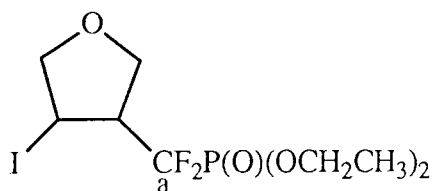
No. 22 3-[(Diethoxyphosphinyl)difluoromethyl]-4-iodooxolane (163)

Chemical Shift/p.p.m.	Multiplicity	Coupling Constant/Hz	Relative Intensity	Assignment
^{19}F -111.19	d d	$^2J_{\text{FP}}=85.0$ $^3J_{\text{FH}}=17.9$	2	a

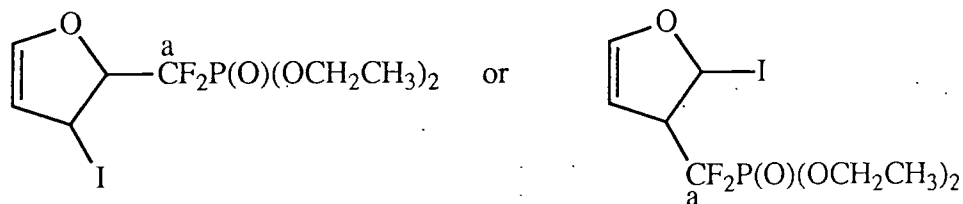
No. 23 3-[(Diethoxyphosphinyl)difluoromethyl]-4,5-dihydro-2-iodooxolane or 2-[(diethoxyphosphinyl)difluoromethyl]-4,5-dihydro-3-iodooxolane (164)

Chemical Shift/p.p.m.	Multiplicity	Coupling Constant/Hz	Relative Intensity	Assignment
^{19}F -108.77	d	$^2J_{\text{FP}}=104.0$	2	a

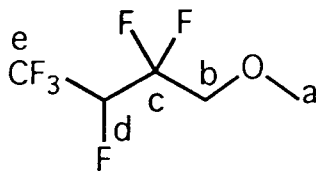
No. 24 Methoxy-2,2,3,4,4,4-hexafluorobutane (173)

Chemical Shift/p.p.m.	Multiplicity	Coupling Constant/Hz	Relative Intensity	Assignment
<i>¹H</i>				
3.467	s		3	a
3.675	AB	$^2J_{HH}=11.4$	1	b
	d	$^3J_{HF}=11.4$		
	d	$^3J_{HF}=8.8$		
	d	$^4J_{HF}=2.4$		
3.813	AB	$^2J_{HH}=11.4$	1	b
	d	$^3J_{HF}=22.8$		
	d	$^3J_{HF}=6.4$		
	d	$^4J_{HF}=3.6$		
5.027	d	$^2J_{HF}=42.2$	1	d
	d	$^3J_{HF}=21.2$		
	q	$^3J_{HF}=6.0$		
	d	$^3J_{HF}=4.8$		
<i>¹³C</i>				
59.830	s			a
70.055	d	$^2J_{CF}=33.6$		b
	d	$^2J_{CF}=13.0$		
83.353	d	$^1J_{CF}=194.1$		d
	q	$^2J_{CF}=34.7$		
	d	$^2J_{CF}=34.7$		
	d	$^2J_{CF}=25.1$		
117.000	t	$^1J_{CF}=250.1$		c
	d	$^2J_{CF}=24.4$		
120.895	q	$^1J_{CF}=276.2$		e
	d	$^2J_{CF}=25.7$		
<i>¹⁹F</i>				
-74.545	s		3	e
-117.708	AB	$^2J_{FF}=276.1$	1	c
	m			
-121.538	AB	$^2J_{FF}=276.5$	1	c
	m			
-214.758	d	$^2J_{FH}=42.1$	1	d
	m			

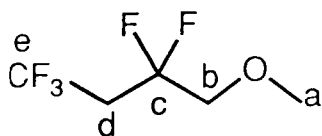
No. 25 Methoxy-1,1,3,3,3-pentafluorobutane (174)

	Chemical Shift/p.p.m.	Multiplicity	Coupling Constant/Hz	Relative Intensity	Assignment
1H	2.822	q	$^3J_{HF}=14.4$	2	d
		t	$^3J_{HF}=10.4$		
	3.443	s		3	a
	3.621	t	$^3J_{HF}=12.4$	2	b
^{13}C	37.890	t	$^2J_{CF}=30.2$		d
		q	$^2J_{CF}=26.3$		
	59.867	s			a
	72.787	t	$^2J_{CF}=31.3$		b
		d	$^4J_{CF}=1.2$		
	119.134	t	$^1J_{CF}=244.5$		c
		q	$^3J_{CF}=3.0$		
^{19}F	124.076	q	$^1J_{CF}=276.2$		e
		t	$^3J_{CF}=5.7$		
	-62.799	s			e
	-104.101	s			c

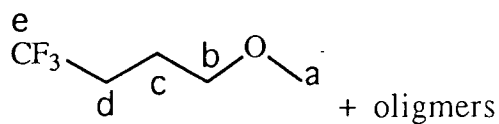
No. 26 Methoxy-4,4,4-trifluorobutane (175)

	Chemical Shift/p.p.m.	Multiplicity	Coupling Constant/Hz	Relative Intensity	Assignment	
1H	1.544 to 3.000	br m			b,c,d	
	2.055	q	$^3J_{HF}=2.7$		d	
	3.681	s			a	
^{13}C	21.751 to 22.019	m			c	
	28.902 to 31.694	m			b or d	
	38.779 to 39.659	m			b or d	
	54.960	s			a	
	128.137 and 129.077	q	$^1J_{CF}=280.0$		e	
		q	$^1J_{CF}=280.0$		e	
^{19}F	-64.04 and -67.60	m			e	
		m			e	

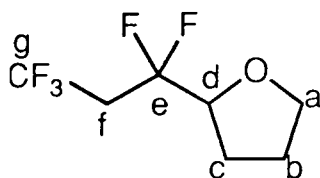
No. 27 2-(1,1,3,3,3-Pentafluoropropyl)oxolane (177)

Chemical Shift/p.p.m.	Multiplicity	Coupling Constant/Hz	Relative Intensity	Assignment
<i>¹H</i>				
2.074			2	c
2.858	t	³ J _{HF} =20.7	2	f
	q	³ J _{HF} =9.4		
	d	⁴ J _{HH} =1.1		
3.837	d	² J _{HH} =22.0	1	a
	t	³ J _{HH} =7.2		
3.891	d	² J _{HH} =22.0	1	a
	t	³ J _{HH} =7.2		
4.082	d	³ J _{HF} =24.8	1	d
		³ J _{HH} =8.4		
		³ J _{HF} =6.4		
		³ J _{HH} =2.8		
<i>¹³C</i>				
24.755	d	⁴ J _{CF} =2.1		c
25.656	s			b
37.780	q	³ J _{CF} =30.1		f
	d	³ J _{CF} =23.6		
69.520	s			a
78.462	d	² J _{CF} =33.2		d
	d	² J _{CF} =0.7		
119.791	d	¹ J _{CF} =253.5		e
	d	¹ J _{CF} =246.3		
	q	³ J _{CF} =2.9		
126.811	q	¹ J _{CF} =276.8		g
	d	³ J _{CF} =7.4		
<i>¹⁹F</i>				
-74.960	t	³ J _{FH} =13.9	3	g
	d	⁴ J _{FF} =13.9		
	d	⁴ J _{FF} =5.6		
-118.130	AB	² J _{FF} =276.2	1	e
	t	³ J _{FH} =17.8		
	q	⁴ J _{FF} =10.9		
	d	³ J _{FH} =4.9		
-121.880	AB	² J _{FF} =276.2	1	e
	t	³ J _{FH} =18.4		
	q	⁴ J _{FF} =6.8		

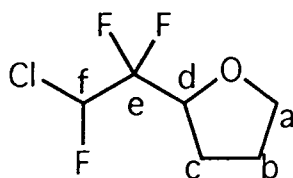
No. 28 2-(2-Chloro-1,1,2-trifluoroethyl)oxolane (RS/SR)(177)

Chemical Shift/p.p.m.	Multiplicity	Coupling Constant/Hz	Relative Intensity	Assignment
<i>¹H</i>				
1.978	m		2	b
2.119	m		2	c
3.837	d	$^2J_{HH}=22.0$	1	a
	t	$^3J_{HH}=7.2$		
3.902	d	$^2J_{HH}=14.8$	1	a
	t	$^3J_{HH}=7.2$		
4.321	d	$^3J_{HH}=11.6$	1	d
	m			
6.383	d	$^2J_{HF}=47.2$	1	f
	d	$^3J_{HH}=14.4$		
	d	$^3J_{HF}=1.6$		
<i>¹³C</i>				
24.892	d	$^4J_{CF}=3.4$		c
25.648	s			b
69.790	s			a
75.288	d	$^2J_{CF}=32.7$		d
	d	$^2J_{CF}=24.8$		
96.850	d	$^1J_{CF}=244.9$		f
	d	$^2J_{CF}=41.2$		
	d	$^2J_{CF}=27.9$		
116.334	d	$^1J_{CF}=254.1$		e
	d	$^1J_{CF}=251.7$		
	d	$^2J_{CF}=27.1$		
<i>¹⁹F</i>				
-126.399	AB	$^2J_{FF}=264.2$	1	e
	d	$^3J_{FF}=3.4$		
	m			
-127.458	AB	$^2J_{FF}=264.2$	1	e
	d	$^3J_{FF}=22.2$		
	d	$^3J_{FH}=9.4$		
-152.787	d	$^2J_{FH}=47.4$	1	f
	d	$^3J_{FF}=15.1$		
	d	$^3J_{FF}=9.8$		
	d	$^4J_{FH}=3.0$		

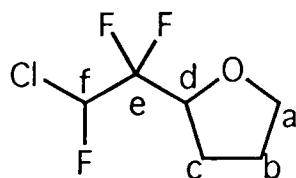
No. 28 2-(2-Chloro-1,1,2-trifluoroethyl)oxolane (RR/SS)(177)

Chemical Shift/p.p.m.	Multiplicity	Coupling Constant/Hz	Relative Intensity	Assignment
<i>¹H</i>				
1.942	m		2	b
2.119	m		2	c
3.857	d	² J _{HH} =14.0	1	a
	t	³ J _{HH} =6.8		
3.892	d	² J _{HH} =14.0	1	a
	t	³ J _{HH} =6.8		
4.377	d	³ J _{HH} =16.8	1	d
	m			
6.335	d	² J _{HF} =48.8	1	f
	d	³ J _{HF} =12.8		
	d	³ J _{HF} =3.6		
<i>¹³C</i>				
24.955	d	⁴ J _{CF} =3.1		c
25.610	s			b
69.790	s			a
76.088	d	² J _{CF} =31.3		d
	d	² J _{CF} =24.0		
96.210	d	¹ J _{CF} =252.9		f
	d	² J _{CF} =35.1		
	d	² J _{CF} =27.5		
117.736	t	¹ J _{CF} =254.1		e
	d	² J _{CF} =19.0		
<i>¹⁹F</i>				
-126.072	AB	² J _{FF} =255.5	1	e
	d	³ J _{FH} =12.4		
	d	³ J _{FF} =12.4		
-128.202	AB	² J _{FF} =255.5	1	e
	d	³ J _{FH} =19.6		
	d	³ J _{FF} =19.6		
-160.697	d	² J _{FH} =48.9	1	f
	t	³ J _{FF} =14.1		

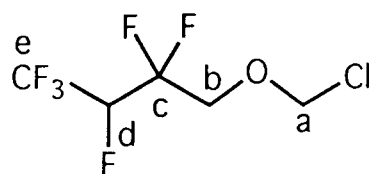
No. 29 Chloromethoxy-2,2,3,4,4,4-hexafluorobutane (185)

	Chemical Shift/p.p.m.	Multiplicity	Coupling Constant/Hz	Relative Intensity	Assignment
1H	3.675	AB	$^2J_{HH}=11.0$	1	b
		d	$^3J_{HF}=10.3$		
		d	$^3J_{HF}=2.5$		
	4.082	AB	$^2J_{HH}=11.0$	1	b
		d	$^3J_{HF}=7.0$		
		d	$^3J_{HF}=3.3$		
	4.984	d	$^2J_{HF}=43.25$	1	d
		d	$^3J_{HF}=21.0$		
		q	$^3J_{HF}=5.8$		
	d	$^3J_{HF}=0.8$			
^{19}F	5.551	m		2	a
	-74.527	s			e
	-116.948	AB	$^2J_{FF}=279.4$		c
		m			
	-121.636	AB	$^2J_{FF}=280.3$		c
		m			
	d	$^2J_{FH}=40.7$		d	
	m				

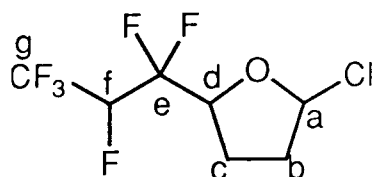
No. 30 2-Chloro-5-(1,1,2,3,3,3-hexafluoropropyl)oxolane (major isomer)(185)

Chemical Shift/p.p.m.	Multiplicity	Coupling Constant/Hz	Relative Intensity	Assignment
<i>¹H</i>				
2.143	m		2	b or c
2.402	d	$^2J_{HH}=15.1$	2	b or c
	d	$^3J_{HH}=15.1$		
4.653	t	$^3J_{HF}=9.5$	1	d
	m			
4.945	d	$^2J_{HF}=42.7$	1	f
	d	$^3J_{HF}=21.8$		
	q	$^3J_{HF}=5.5$		
6.351	m		1	a
<i>¹⁹F</i>				
-75.117	m		3	g
-125.098	AB	$^2J_{FF}=272.5$	1	e
	m			
-131.704	AB	$^2J_{FF}=272.3$	1	e
	m			
-213.219	d	$^2J_{FH}=42.1$	1	f
	m			

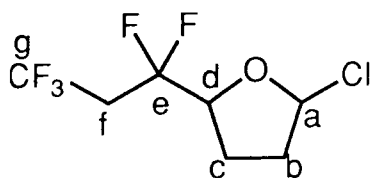
No. 31 2-Chloro-5-(1,1,3,3,3-pentafluoropropyl)oxolane (major isomer)(187)

Chemical Shift/p.p.m.	Multiplicity	Coupling Constant/Hz	Relative Intensity	Assignment
<i>¹H</i>				
2.221	m		2	b or c
2.363	d	$^2J_{HH}=9.6$	2	b or c
	d	$^3J_{HH}=9.6$		
	d	$^3J_{HH}=3.5$		
2.797	m		2	f
4.495	d	$^3J_{HF}=22.1$	1	d
	d	$^3J_{HH}=5.9$		
	d	$^3J_{HF}=4.2$		
	d	$^3J_{HH}=4.2$		
6.323	m		1	a
<i>¹⁹F</i>				
-62.805	m		3	g
-109.650	AB	$^2J_{FF}=270.2$	1	e
	d	$^3J_{FH}=14.8$		
	t	$^3J_{FH}=14.8$		
-117.337	AB	$^2J_{FF}=272.3$	1	e
	d	$^3J_{FH}=22.8$		
	t	$^3J_{FH}=22.8$		

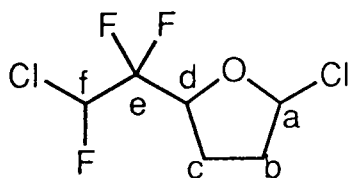
No. 32 2-Chloro-5-(2-chloro-1,1,2-trifluoroethyl)oxolane (major isomer)(188)

Chemical Shift/p.p.m.	Multiplicity	Coupling Constant/Hz	Relative Intensity	Assignment
<i>¹H</i>				
2.240 to 3.276	m		4	b, c
4.775	d	³ J _{HF} =20.8	1	d
6.269	m		1	f
	d	² J _{HF} =50.0		
	d	³ J _{HF} =15.0		
6.343	d	³ J _{HF} =1.0	1	
	m		1	a
<i>¹⁹F</i>				
-126.396	AB	² J _{FF} =261.5	1	e
-129.391	m		1	e
	AB	² J _{FF} =261.5		
-153.195	m		1	f
	d	² J _{FH} =48.0		
	m			

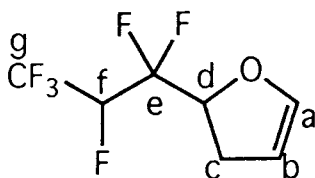
No. 33 2-(1,1,2,3,3,3-Hexafluoropropyl)-4,5-dihydrofuran (189)

Chemical Shift/p.p.m.	Multiplicity	Coupling Constant/Hz	Relative Intensity	Assignment
1H				
1.998 to 2.339	m		3	b,c
4.378	m		1	d
6.269	d	$^2J_{HF}=43.0$	1	f
	m			
5.456	m		1	a

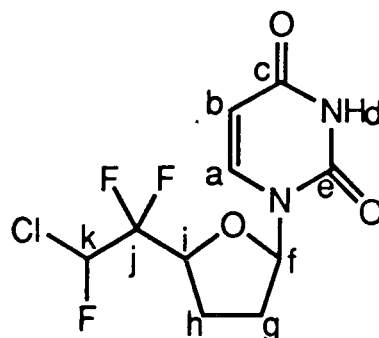
No.34 2-(2-Chloro-1,1,2-trifluoroethyl)-5-uridyloxolane (α) (192)

	Chemical Shift/p.p.m.	Multiplicity	Coupling Constant/Hz	Relative Intensity	Assignment
1H	2.128	m		1	g
	2.329	AB	$^2J_{HH}=8.0$	1	h
	2.370	AB	$^2J_{HH}=8.0$	1	h
	2.601	d	$^2J_{HH}=6.4$	1	g
		d	$^3J_{HH}=6.4$		
		d	$^3J_{HH}=6.4$		
		d	$^3J_{HH}=6.4$		
	4.810	m		1	i
	5.787	d	$^3J_{HH}=8.0$	1	b
	6.111 or	t	$^3J_{HH}=6.4$	1	f
	6.151				
	6.289	m		1	k
	7.237 or	d	$^3J_{HH}=8.0$	1	a
7.248					
9.240	br s		1	d	
^{13}C	23.502	m			h
	30.507	s			g
	75.978	d	$^2J_{CF}=69.8$		i
		d	$^2J_{CF}=8.75$		
	86.031	s			f
	94.720	m			k
	102.814	s			b
	116.764	m			j
	139.332	s			a
	150.286	s			e
	162.806	s			c
^{19}F	-127.050	AB	$^2J_{FF}=272.0$	1	j
		d	$^3J_{FF}=13.9$		
		d	$^3J_{FH}=4.1$		
	-128.123	AB	$^2J_{FF}=267.5$	1	j
		d	$^3J_{FH}=19.9$		
		d	$^3J_{FF}=10.2$		
	-154.421	d	$^2J_{FH}=47.4$	1	k
		d	$^3J_{FF}=13.2$		
		d	$^3J_{FF}=10.2$		
		d	$^3J_{FH}=2.6$		

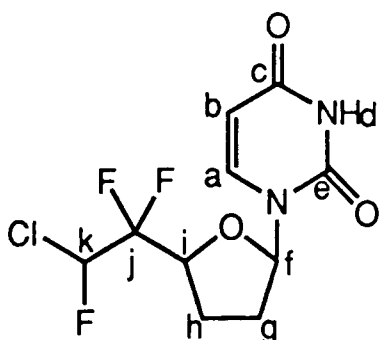
No.34 2-(2-Chloro-1,1,2-trifluoroethyl)-5-uridyloxolane (β) (192)

Chemical Shift/p.p.m.	Multiplicity	Coupling Constant/Hz	Relative Intensity	Assignment
<i>¹H</i>				
2.040	m		1	g
2.322	AB	$^2J_{HH}=8.4$	1	h
2.361	AB	$^2J_{HH}=8.4$	1	h
2.449	d	$^2J_{HH}=6.4$	1	g
	d	$^3J_{HH}=6.4$		
	d	$^3J_{HH}=6.4$		
	d	$^3J_{HH}=6.4$		
4.532	m		1	i
5.819	d	$^3J_{HH}=8.4$	1	b
6.289 or	t	$^3J_{HH}=6.4$	1	f
6.309				
6.289	m		1	k
7.321 or	d	$^3J_{HH}=8.0$	1	a
7.372				
9.240	br s		1	d
<i>¹⁹F</i>				
-127.008	AB	$^2J_{FF}=254.0$	1	j
	d	$^3J_{FF}=11.7$		
	d	$^3J_{FH}=11.7$		
-128.562	AB	$^2J_{FF}=260.4$	1	j
	d	$^3J_{FH}=13.2$		
	d	$^3J_{FF}=12.2$		
-154.692	d	$^2J_{FH}=47.0$	1	k
	t	$^3J_{FF}=12.4$		
	d	$^3J_{FH}=3.0$		

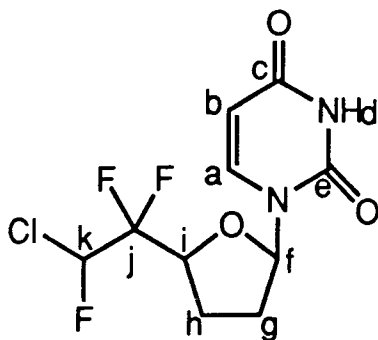
No.34 2-(2-Chloro-1,1,2-trifluoroethyl)-5-uridyloxolane (α) (192)

Chemical Shift/p.p.m.	Multiplicity	Coupling Constant/Hz	Relative Intensity	Assignment
1H				
2.128	m		1	g
2.329	AB	$^2J_{HH}=8.0$	1	h
2.370	AB	$^2J_{HH}=8.0$	1	h
2.601	d	$^2J_{HH}=6.4$	1	g
	d	$^3J_{HH}=6.4$		
	d	$^3J_{HH}=6.4$		
	d	$^3J_{HH}=6.4$		
4.810	m		1	i
5.787	d	$^3J_{HH}=8.0$	1	b
6.111 or	t	$^3J_{HH}=6.4$	1	f
6.151				
6.289	m		1	k
7.237 or	d	$^3J_{HH}=8.0$	1	a
7.248				
9.240	br s		1	d
^{13}C				
23.642	m			h
30.484	s			g
75.636	d	$^2J_{CF}=59.4$		i
	d	$^2J_{CF}=15.4$		
85.982	s			f
97.493	m			k
103.364	s			b
116.764	m			j
139.264	s			a
149.990	s			e
163.030	s			c
^{19}F				
-129.045	m		2	j
-161.231	d	$^2J_{FH}=48.5$	1	k
	t	$^3J_{FF}=13.2$		

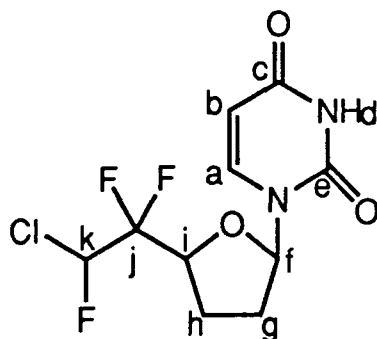
No.34 2-(2-Chloro-1,1,2-trifluoroethyl)-5-uridyloxolane (β) (192)

Chemical Shift/p.p.m.	Multiplicity	Coupling Constant/Hz	Relative Intensity	Assignment
<i>¹H</i>				
2.040	m		1	g
2.322	AB	$^2J_{HH}=8.4$	1	h
2.361	AB	$^2J_{HH}=8.4$	1	h
2.449	d	$^2J_{HH}=6.4$	1	g
	d	$^3J_{HH}=6.4$		
	d	$^3J_{HH}=6.4$		
	d	$^3J_{HH}=6.4$		
4.532	m		1	i
5.819	d	$^3J_{HH}=8.4$	1	b
6.289 or	t	$^3J_{HH}=6.4$	1	f
6.309				
6.289	m		1	k
7.321 or	d	$^3J_{HH}=8.0$	1	a
7.372				
9.240	br s		1	d
<i>¹⁹F</i>				
-129.045	m		2	j
-162.263	d	$^2J_{FH}=48.9$	1	k
	t	$^3J_{FF}=13.9$		

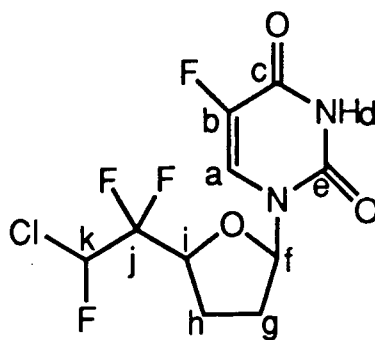
No.35 2-(2-Chloro-1,1,2-trifluoroethyl)-5-(5-fluorouracyl)oxolane (α) (193)

	Chemical Shift/p.p.m.	Multiplicity	Coupling Constant/Hz	Relative Intensity	Assignment
^1H	2.117	m		1	g
	2.350	m		2	h
	2.613	m		1	g
	4.839	d	$^3J_{\text{HF}}=16.0$	1	i
		d	$^3J_{\text{HF}}=8.0$		
		d	$^3J_{\text{HH}}=8.0$		
		d	$^3J_{\text{HH}}=5.6$		
	6.164	d	$^3J_{\text{HH}}=5.2$	1	f
		m			
	6.338	d	$^2J_{\text{HF}}=47.2$	1	k
		m			
	7.323	d	$^3J_{\text{HF}}=6.0$	1	b
	7.377 or 7.379	d	$^3J_{\text{HF}}=6.0$	1	a
9.594	br s		1	d	
^{13}C	23.067	m			h
	31.462	s			g
	76.000	m			i
	86.375	s			f
	96.275	d	$^1J_{\text{CF}}=246.5$		k
		t	$^2J_{\text{CF}}=32.9$		
	116.430	m			j
	123.452	d	$^2J_{\text{CF}}=34.0$		a
	140.712	d	$^1J_{\text{CF}}=239.6$		b
	149.041	s			e
156.604	s			c	
^{19}F	-120.055	AB	$^2J_{\text{FF}}=268.3$	1	j
		m			
	-121.243	AB	$^2J_{\text{FF}}=268.6$	1	j
		d	$^3J_{\text{FH}}=20.3$		
		d	$^3J_{\text{FF}}=9.8$		
	-147.874	d	$^2J_{\text{FH}}=47.4$	1	k
		d	$^3J_{\text{FF}}=12.8$		
		d	$^3J_{\text{FF}}=9.8$		
-157.971	m	$^3J_{\text{FH}}=2.3$	1	b	

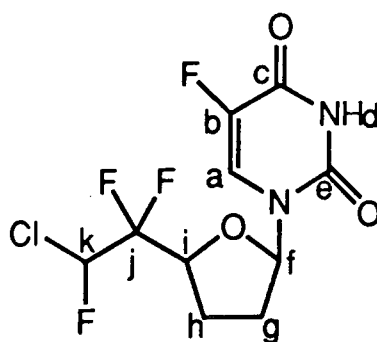
No.35 2-(2-Chloro-1,1,2-trifluoroethyl)-5-(5-fluorouracyl)oxolane (β) (193)

Chemical Shift/p.p.m.	Multiplicity	Coupling Constant/Hz	Relative Intensity	Assignment
1H				
2.042	m		1	g
2.350	m		2	h
2.449	m		1	g
4.546	m		1	i
6.147	d	$^3J_{HH}=4.8$	1	f
	m			
6.338	d	$^2J_{HF}=47.2$	1	k
	m			
7.323	d	$^3J_{HF}=6.0$	1	b
7.435 or	d	$^3J_{HF}=6.0$	1	a
7.437				
9.594	br s		1	d
^{19}F				
-119.959	AB	$^2J_{FF}=260.4$	1	j
	d	$^3J_{FF}=11.7$		
	d	$^3J_{FH}=11.7$		
	d	$^3J_{FH}=5.6$		
	d	$^3J_{FH}=5.6$		
-121.467	AB	$^2J_{FF}=260.4$	1	j
	m			
-148.152	d	$^2J_{FH}=47.4$	1	k
	t	$^3J_{FF}=12.0$		
	d	$^3J_{FH}=3.0$		
-158.072	m		1	b

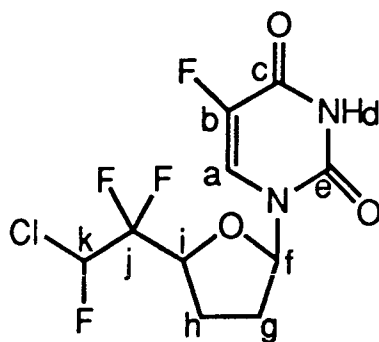
No.35 2-(2-Chloro-1,1,2-trifluoroethyl)-5-(5-fluorouracyl)oxolane (α)(193)

	Chemical Shift/p.p.m.	Multiplicity	Coupling Constant/Hz	Relative Intensity	Assignment
1H	2.117	m		1	g
	2.350	m		2	h
	2.613	m		1	g
	4.791	d	$^3J_{HF}=8.2$	1	i
		d	$^3J_{HF}=5.1$		
		d	$^3J_{HH}=5.1$		
		d	$^3J_{HH}=3.2$		
	6.164	d	$^3J_{HH}=5.2$	1	f
		m			
	6.319	d	$^2J_{HF}=48.4$	1	k
		m			
	7.312	d	$^3J_{HF}=5.6$	1	b
	7.377 or 7.379	d	$^3J_{HF}=6.0$	1	a
9.594	br s		1	d	
^{13}C	23.421	m			h
	30.495	s			g
	76.000	m			i
	88.363	s			f
	96.275	d	$^1J_{CF}=246.5$		k
		t	$^2J_{CF}=32.9$		
	116.430	m			j
	123.487	d	$^2J_{CF}=34.0$		a
	140.860	d	$^1J_{CF}=238.9$		b
149.692	s			e	
156.869	s			c	
^{19}F	-122.212	m		2	j
	-154.141	d	$^2J_{FH}=48.5$	1	k
		t	$^3J_{FF}=12.4$		
	-159.055	m		1	b

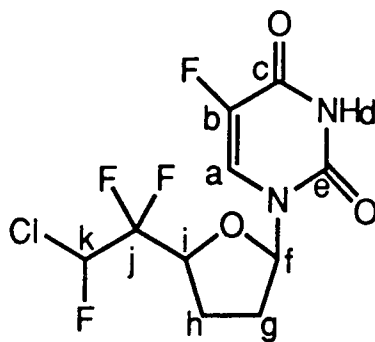
No.35 2-(2-Chloro-1,1,2-trifluoroethyl)-5-(5-fluorouracyl)oxolane (β)(193)

Chemical Shift/p.p.m.	Multiplicity	Coupling Constant/Hz	Relative Intensity	Assignment
<i>¹H</i>				
2.042	m		1	g
2.350	m		2	h
2.449	m		1	g
4.500	m	$^3J_{HF}=16.0$	1	i
6.147	d	$^3J_{HH}=4.8$	1	f
6.319	m			
	d	$^2J_{HF}=48.4$	1	k
7.312	m			
	d	$^3J_{HF}=5.6$	1	b
7.435 or	d	$^3J_{HF}=6.0$	1	a
7.437				
9.594	br s		1	d
<i>¹⁹F</i>				
-122.356	m		2	j
-155.580	d	$^2J_{FH}=48.9$	1	k
	t	$^3J_{FF}=12.0$		
-159.066	m		1	b

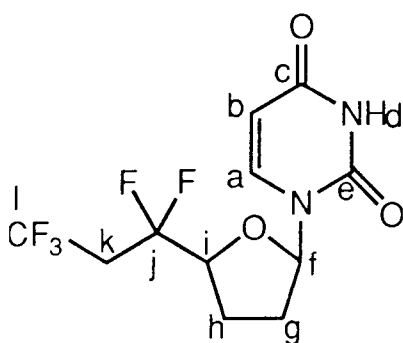
No.36 2-(1,1,3,3,3-Pentafluoropropyl)-5-uridyloxolane (α)(194)

Chemical Shift/p.p.m.	Multiplicity	Coupling Constant/Hz	Relative Intensity	Assignment
<i>¹H</i>				
2.013	m		1	<i>cis</i> g
2.295	m		2	h
2.423	d	$^2J_{HH}=6.4$	1	<i>trans</i> g
	d	$^3J_{HH}=6.4$		
	t	$^3J_{HH}=6.4$		
2.914	t	$^3J_{HF}=17.6$	2	k
	q	$^3J_{HF}=10.0$		
4.248	t	$^3J_{HF}=22.8$	1	i
	d	$^3J_{HH}=6.4$		
5.818	d	$^3J_{HH}=8.4$	1	b
6.299	t	$^3J_{HH}=6.4$	1	f
7.358	d	$^3J_{HH}=8.0$	1	a
9.426	br s		1	d
<i>¹³C</i>				
23.366	d	$^3J_{CF}=4.2$		h
30.950	s			g
38.413	t	$^2J_{CF}=29.0$		k
	q	$^2J_{CF}=9.3$		
78.861	d	$^2J_{CF}=36.6$		i
	d	$^2J_{CF}=25.5$		
88.499	s			f
102.745	s			b
118.668	t	$^1J_{CF}=255.2$		j
	q	$^3J_{CF}=2.6$		
123.572	q	$^1J_{CF}=277.0$		l
	d	$^3J_{CF}=5.7$		
138.789	s			a
150.126	s			e
163.264	s			c
<i>¹⁹F</i>				
-61.408	s		3	l
-109.863	AB	$^2J_{FF}=259.6$	1	j
	m			
-114.920	AB	$^2J_{FF}=259.4$	1	j
	m			

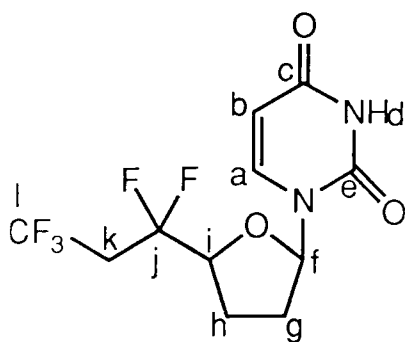
No.36 2-(1,1,3,3,3-Pentafluoropropyl)-5-uridyloxolane (β)(194)

Chemical Shift/p.p.m.	Multiplicity	Coupling Constant/Hz	Relative Intensity	Assignment
<i>¹H</i>				
2.130	m		1	<i>cis</i> g
2.295	m		2	h
2.580	d	$^2J_{HH}=7.2$	1	<i>trans</i> g
	d	$^3J_{HH}=7.2$		
	t	$^3J_{HH}=7.2$		
2.914	t	$^3J_{HF}=16.0$	2	k
	q	$^3J_{HF}=8.8$		
4.548	d	$^3J_{HF}=16.8$	1	i
	d	$^3J_{HH}=10.4$		
	d	$^3J_{HF}=10.4$		
5.748	d	$^3J_{HH}=8.0$	1	b
6.141	d	$^3J_{HH}=6.4$	1	f
	d	$^3J_{HH}=4.8$		
7.256	d	$^3J_{HH}=8.0$	1	a
9.426	br s		1	d
<i>¹³C</i>				
23.497	d	$^3J_{CF}=3.8$		h
30.662	s			g
38.413	t	$^2J_{CF}=29.0$		k
	q	$^2J_{CF}=9.3$		
78.516	d	$^2J_{CF}=36.3$		i
	d	$^2J_{CF}=24.8$		
85.973	s			f
103.397	s			b
118.668	t	$^1J_{CF}=255.2$		j
	q	$^3J_{CF}=2.6$		
123.458	q	$^1J_{CF}=288.5$		l
	d	$^3J_{CF}=9.2$		
139.392	s			a
150.452	s			e
163.018	s			c
<i>¹⁹F</i>				
-61.408	s		3	l
-109.312	AB	$^2J_{FF}=259.4$	1	j
	m			
-114.304	AB	$^2J_{FF}=259.4$	1	j
	m			

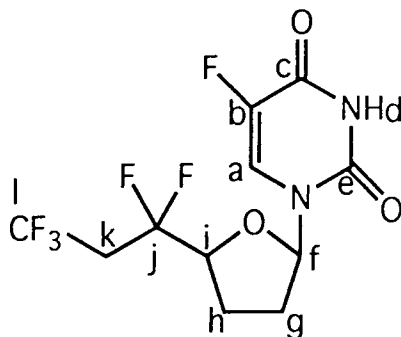
No. 37 2-(1,1,3,3,3-Pentafluoropropyl)-5-(5-fluorouracyl)oxolane (195)

Chemical Shift/p.p.m.	Multiplicity	Coupling Constant/Hz	Relative Intensity	Assignment
<i>¹H</i>				
2.072	m		1	g
2.142	AB	$^2J_{HH}=7.6$	1	h
	m			
2.169	AB	$^2J_{HH}=7.6$	1	h
	m			
2.339	d	$^2J_{HH}=7.0$	1	g
	d	$^3J_{HH}=7.0$		
	d	$^3J_{HH}=7.0$		
3.338	t	$^3J_{HF}=14.4$	2	k
	q	$^3J_{HF}=11.0$		
4.273	d	$^3J_{HH}=15.6$	1	i
	d	$^3J_{HH}=7.8$		
	t	$^3J_{HF}=7.8$		
6.108	t	$^3J_{HH}=6.4$	1	f
	m			
7.740	d	$^3J_{HH}=8.0$	1	a
9.603	br s		1	d
<i>¹³C</i>				
23.533	d	$^3J_{CF}=4.2$		h
31.428	s			g
76.681	d	$^2J_{CF}=35.9$		i
	d	$^2J_{CF}=22.9$		
84.400	m			k
87.145	s			f
118.224	t	$^1J_{CF}=241.4$		j
	d	$^2J_{CF}=22.9$		
122.191	q	$^1J_{CF}=281.2$		l
	d	$^2J_{CF}=25.5$		
125.381	d	$^2J_{CF}=34.4$		a
141.505	d	$^1J_{CF}=233.4$		b
149.978	s			e
157.400	s			c
<i>¹⁹F</i>				
-61.628	s		3	l
-110.282	AB	$^2J_{FF}=257.7$	1	j
	m			
-115.150	AB	$^2J_{FH}=42.1$	1	j
	m			
-167.934	s		1	b

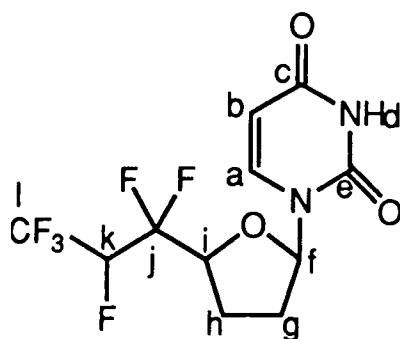
No. 38 2-(1,1,2,3,3,3-Hexafluoropropyl)-5-uridyloxolane (α) (196)

	Chemical Shift/p.p.m.	Multiplicity	Coupling Constant/Hz	Relative Intensity	Assignment
1H	2.157	m		1	g
	2.364	AB	$^2J_{HH}=8.4$	1	h
	2.376	m			
	2.376	AB	$^2J_{HH}=8.4$	1	h
	2.602	m			
	2.602	d	$^2J_{HH}=6.8$	1	g
		d	$^3J_{HH}=6.8$		
		d	$^3J_{HH}=6.8$		
		d	$^3J_{HH}=6.8$		
	4.721	m		1	i
	5.054	d	$^2J_{HF}=43.2$	1	k
		d	$^3J_{HF}=21.2$		
		q	$^3J_{HF}=6.4$		
	5.793	d	$^3J_{HH}=8.0$	1	b
	6.178 or 6.158	t	$^3J_{HH}=6.4$	1	f
7.237	d	$^3J_{HH}=8.4$	1	a	
9.603	br s		1	d	
^{13}C	21.978	d	$^3J_{CF}=3.4$		h
	29.323	s			g
	74.479	d	$^2J_{CF}=35.9$		i
		d	$^2J_{CF}=23.3$		
	83.155	m			k
	84.786	s			f
	102.643	s			b
	115.501	t	$^1J_{CF}=251.3$		j
		d	$^2J_{CF}=19.8$		
	119.554	q	$^1J_{CF}=286.5$		l
		d	$^2J_{CF}=24.8$		
	138.303	s			a
149.447	s			e	
161.956	s			c	
^{19}F	-75.818	d	$^3J_{FH}=10.9$	3	l
		d	$^3J_{FF}=10.9$		
		t	$^4J_{FF}=10.9$		
	-128.052	AB	$^2J_{FF}=273.5$	1	j
		d	$^3J_{FF}=21.4$		
		d	$^3J_{FH}=21.4$		
	t	$^4J_{FF}=10.9$			

-131.739	AB	${}^2J_{FF}=272.4$	1	j
	d	${}^3J_{FF}=10.8$		
	d	${}^3J_{FH}=10.8$		
	d	${}^4J_{FF}=10.8$		
-214.166	d	${}^2J_{FH}=43.3$	1	k
	t	${}^3J_{FF}=12.8$		
	d	${}^3J_{FF}=2.8$		

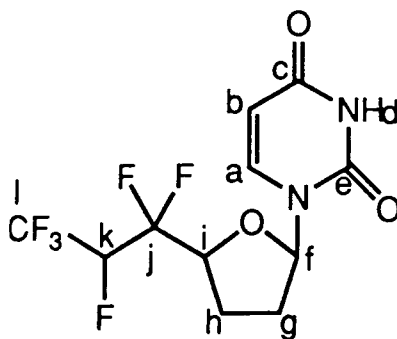
No. 38 2-(1,1,2,3,3,3-Hexafluoropropyl)-5-uridyloxolane (β) (196)

	Chemical Shift/p.p.m.	Multiplicity	Coupling Constant/Hz	Relative Intensity	Assignment
^1H	2.059	d	$^2J_{\text{HH}}=6.4$	1	g
		d	$^3J_{\text{HH}}=6.4$		
		d	$^3J_{\text{HH}}=6.4$		
		d	$^3J_{\text{HH}}=6.4$		
	2.330	AB	$^2J_{\text{HH}}=8.4$	1	h
	2.376	m			
		AB	$^2J_{\text{HH}}=8.4$	1	h
		m			
	2.448	d	$^2J_{\text{HH}}=6.8$	1	g
		d	$^3J_{\text{HH}}=6.8$		
		d	$^3J_{\text{HH}}=6.8$		
		d	$^3J_{\text{HH}}=6.8$		
	4.415	m		1	i
5.054	d	$^2J_{\text{HF}}=43.2$	1	k	
	d	$^3J_{\text{HF}}=21.2$			
	q	$^3J_{\text{HF}}=6.4$			
5.800	d	$^3J_{\text{HH}}=8.0$ or 7.2	1	b	
5.834					
6.309 or	t	$^3J_{\text{HH}}=6.4$	1	f	
6.361					
7.299 or	d	$^3J_{\text{HH}}=8.4$	1	a	
7.373					
9.618	br s		1	d	
^{19}F	-75.818	d	$^3J_{\text{FH}}=10.9$	3	l
		d	$^3J_{\text{FF}}=10.9$		
		t	$^4J_{\text{FF}}=10.9$		
	-126.199	AB	$^2J_{\text{FF}}=272.0$	1	j
		d	$^3J_{\text{FF}}=21.4$		
		d	$^3J_{\text{FH}}=21.4$		
		t	$^4J_{\text{FF}}=10.5$		
	-130.871	AB	$^2J_{\text{FF}}=272.4$	1	j
		d	$^3J_{\text{FF}}=9.0$		
		d	$^3J_{\text{FH}}=9.0$		
		d	$^4J_{\text{FF}}=9.0$		
	-214.503	d	$^2J_{\text{FH}}=43.3$	1	k
		t	$^3J_{\text{FF}}=12.8$		

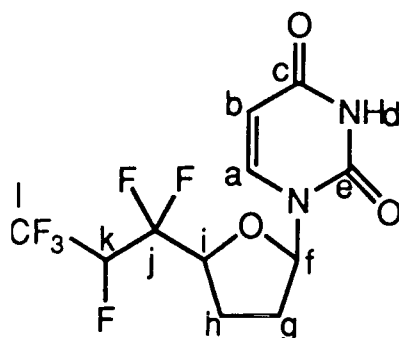
No. 38 2-(1,1,2,3,3,3-Hexafluoropropyl)-5-uridyloxolane (α)(196)

	Chemical Shift/p.p.m.	Multiplicity	Coupling Constant/Hz	Relative Intensity	Assignment
^1H	2.157	m		1	g
	2.364	AB	$^2J_{\text{HH}}=8.4$	1	h
		m			
	2.376	AB	$^2J_{\text{HH}}=8.4$	1	h
		m			
	2.602	d	$^2J_{\text{HH}}=6.8$	1	g
		d	$^3J_{\text{HH}}=6.8$		
		d	$^3J_{\text{HH}}=6.8$		
		d	$^3J_{\text{HH}}=6.8$		
	4.721	m		1	i
	5.054	d	$^2J_{\text{HF}}=43.2$	1	k
		d	$^3J_{\text{HF}}=21.2$		
		q	$^3J_{\text{HF}}=6.4$		
	5.793	d	$^3J_{\text{HH}}=8.0$	1	b
6.178 or 6.158	t	$^3J_{\text{HH}}=6.4$	1	f	
7.237	d	$^3J_{\text{HH}}=8.4$	1	a	
9.603	br s		1	d	
^{13}C	21.714	d	$^3J_{\text{CF}}=3.8$		h
	29.380	s			g
	77.378	d	$^2J_{\text{CF}}=31.3$		i
		d	$^2J_{\text{CF}}=24.4$		
	83.158	m			k
	85.135	s			f
	101.903	s			b
	115.501	t	$^1J_{\text{CF}}=251.3$		j
		d	$^2J_{\text{CF}}=19.8$		
	119.554	q	$^1J_{\text{CF}}=286.5$		l
		d	$^2J_{\text{CF}}=24.8$		
	138.413	s			a
149.143	s			e	
162.267	s			c	
^{19}F	-76.330	d	$^3J_{\text{FH}}=8.7$	3	l
		d	$^3J_{\text{FF}}=8.7$		
		t	$^4J_{\text{FF}}=8.7$		
	-122.103	AB	$^2J_{\text{FF}}=273.1$	1	j
	-125.790	m AB m	$^2J_{\text{FF}}=272.4$	1	j

-218.680

d

 ${}^2J_{FH}=44.4$

1

k

q

 ${}^3J_{FF}=10.9$

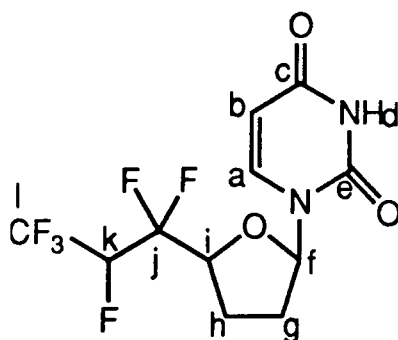
No. 38 2-(1,1,2,3,3,3-Hexafluoropropyl)-5-uridyloxolane (β) (196)

Chemical Shift/p.p.m.	Multiplicity	Coupling Constant/Hz	Relative Intensity	Assignment
1H				
2.059	d	$2J_{HH}=6.4$	1	g
	d	$3J_{HH}=6.4$		
	d	$3J_{HH}=6.4$		
	d	$3J_{HH}=6.4$		
2.330	AB	$2J_{HH}=8.4$	1	h
	m			
2.376	AB	$2J_{HH}=8.4$	1	h
	m			
2.448	d	$2J_{HH}=6.8$	1	g
	d	$3J_{HH}=6.8$		
	d	$3J_{HH}=6.8$		
	d	$3J_{HH}=6.8$		
4.415	m		1	i
5.054	d	$2J_{HF}=43.2$	1	k
	d	$3J_{HF}=21.2$		
	q	$3J_{HF}=6.4$		
5.800	d	$3J_{HH}=8.0$ or 7.2	1	b
5.834				
6.309 or	t	$3J_{HH}=6.4$	1	f
6.361				
7.299 or	d	$3J_{HH}=8.4$	1	a
7.373				
9.618	br s		1	d
^{19}F				
-75.818	d	$3J_{FH}=10.9$	3	l
	d	$3J_{FF}=10.9$		
	t	$4J_{FF}=10.9$		
-122.545	AB	$2J_{FF}=271.6$	1	j
	m			
-125.505	AB	$2J_{FF}=270.1$	1	j
	m			
-219.635	d	$2J_{FH}=44.0$	1	k
	q	$3J_{FF}=10.5$		

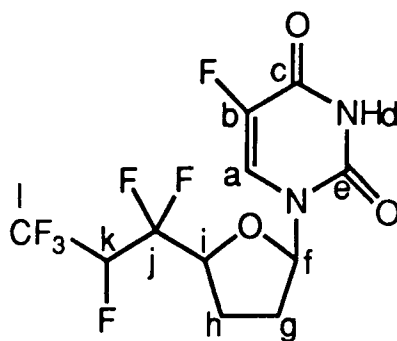
No. 39 2-(1,1,2,3,3,3-Hexafluoropropyl)-5-(5-fluorouracyl)oxolane (α) (197)

Chemical Shift/p.p.m.	Multiplicity	Coupling Constant/Hz	Relative Intensity	Assignment
1H				
2.286	m		1	g
2.428	d	$^3J_{HH}=11.4$	2	h
	t	$^3J_{HH}=11.4$		
2.529	m		1	g
4.971	m		1	i
5.800	d	$^2J_{HF}=40.2$	1	k
	m			
6.314	t	$^3J_{HH}=5.1$	1	f
7.914	d	$^3J_{HF}=8.0$	1	a
10.006	br s		1	d
^{13}C				
23.533	d	$^3J_{CF}=4.2$		h
31.428	s			g
76.681	d	$^2J_{CF}=35.9$		i
	d	$^2J_{CF}=22.9$		
84.400	m			k
87.145	s			f
118.224	t	$^1J_{CF}=241.4$		j
	d	$^2J_{CF}=22.9$		
122.191	q	$^1J_{CF}=281.2$		l
	d	$^2J_{CF}=25.5$		
125.381	d	$^2J_{CF}=34.4$		a
141.505	d	$^1J_{CF}=233.4$		b
149.978	s			e
157.400	s			c
^{19}F				
-74.595	d	$^3J_{FH}=22.2$	3	l
	d	$^3J_{FF}=10.5$		
	t	$^4J_{FF}=5.3$		
-126.471	AB	$^2J_{FF}=265.6$	1	j
	m			
-129.412	AB	$^2J_{FF}=265.6$	1	j
	m			
-168.202	m		1	b
-214.457	d	$^2J_{FH}=42.1$	1	k
	d	$^3J_{FF}=10.5$		
	q	$^3J_{FF}=10.5$		
	d	$^4J_{FH}=3.0$		

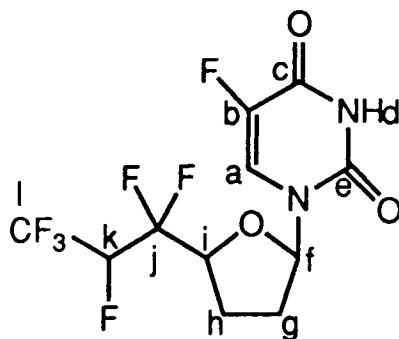
No. 39 2-(1,1,2,3,3,3-Hexafluoropropyl)-5-(5-fluorouracyl)oxolane (β) (197)

Chemical Shift/p.p.m.	Multiplicity	Coupling Constant/Hz	Relative Intensity	Assignment
1H				
2.350	m		1	g
2.428	d	$^3J_{HH}=11.4$	2	h
	t	$^3J_{HH}=11.4$		
2.543	m		1	g
4.564	m		1	i
5.800	d	$^2J_{HF}=40.2$	1	k
	m			
6.279	t	$^3J_{HH}=5.1$	1	f
7.664	d	$^3J_{HF}=6.9$	1	a
10.006	br s		1	d
^{19}F				
-74.595	d	$^3J_{FH}=22.2$	3	l
	d	$^3J_{FF}=10.5$		
	t	$^4J_{FF}=5.3$		
-125.176	AB	$^2J_{FF}=265.6$	1	j
	m			
-128.824	AB	$^2J_{FF}=265.6$	1	j
	m			
-167.330	m		1	b
-214.457	d	$^2J_{FH}=42.1$	1	k
	d	$^3J_{FF}=10.5$		
	q	$^3J_{FF}=10.5$		
	d	$^4J_{FH}=3.0$		

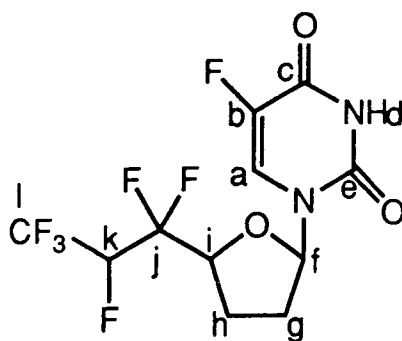
No. 39 2-(1,1,2,3,3,3-Hexafluoropropyl)-5-(5-fluorouracyl)oxolane (α) (197)

Chemical Shift/p.p.m.	Multiplicity	Coupling Constant/Hz	Relative Intensity	Assignment
<i>¹H</i>				
2.286	m		1	g
2.428	d	$^3J_{HH}=11.4$	2	h
	t	$^3J_{HH}=11.4$		
2.529	m		1	g
5.042	m		1	i
5.864	d	$^2J_{HF}=40.0$	1	k
	m			
6.264	t	$^3J_{HH}=5.7$	1	f
7.791	d	$^3J_{HF}=8.0$	1	a
10.006	br s		1	d
<i>¹³C</i>				
23.609	d	$^3J_{CF}=4.2$		h
31.598	s			g
77.765	d	$^2J_{CF}=35.5$		i
	d	$^2J_{CF}=23.3$		
84.400	m			k
87.399	s			f
118.224	t	$^1J_{CF}=241.4$		j
	d	$^2J_{CF}=22.9$		
122.191	q	$^1J_{CF}=281.2$		l
	d	$^2J_{CF}=25.5$		
124.605	d	$^2J_{CF}=34.0$		a
141.558	d	$^1J_{CF}=232.6$		b
149.796	s			e
157.662	s			c
<i>¹⁹F</i>				
-75.011	m		3	l
-122.611	AB	$^2J_{FF}=274.5$	1	j
	m			
-124.470	AB	$^2J_{FF}=274.5$	1	j
	m			
-168.202	m		1	b
-217.604	d	$^2J_{FH}=43.6$	1	k
	d	$^3J_{FF}=19.8$		
	q	$^3J_{FF}=11.5$		

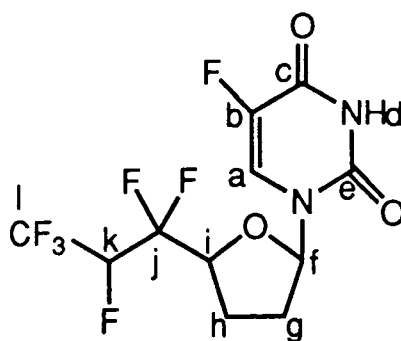
No. 39 2-(1,1,2,3,3,3-Hexafluoropropyl)-5-(5-fluorouracyl)oxolane (β) (197)

Chemical Shift/p.p.m.	Multiplicity	Coupling Constant/Hz	Relative Intensity	Assignment
1H				
2.350	m		1	g
2.428	d	$^3J_{HH}=11.4$	2	h
	t	$^3J_{HH}=11.4$		
2.543	m		1	g
4.629	m		1	i
5.864	d	$^2J_{HF}=40.0$	1	k
	m			
6.279	t	$^3J_{HH}=5.1$	1	f
7.686	d	$^3J_{HF}=8.0$	1	a
10.006	br s		1	d
^{19}F				
-75.011	m		3	l
-122.611	AB	$^2J_{FF}=274.5$	1	j
	m			
-124.470	AB	$^2J_{FF}=274.5$	1	j
	m			
-167.476	m		1	b
-217.835	d	$^2J_{FH}=43.6$		
	d	$^3J_{FF}=19.8$		
	q	$^3J_{FF}=11.5$		

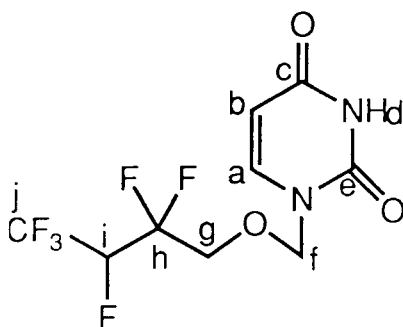
No. 40 Uradylmethoxy-2,2,3,4,4,4-hexafluorobutane (198)

	Chemical Shift/p.p.m.	Multiplicity	Coupling Constant/Hz	Relative Intensity	Assignment
^1H	3.991	AB	$^2\text{J}_{\text{HH}}=11.2$ $^3\text{J}_{\text{HF}}=8.8$ $^3\text{J}_{\text{HF}}=2.4$	1	g
	4.054	d	$^3\text{J}_{\text{HF}}=21.0$	1	g
	4.978	AB	$^2\text{J}_{\text{HH}}=11.6$ $^3\text{J}_{\text{HF}}=8.0$ $^4\text{J}_{\text{HF}}=3.6$	1	i
		d	$^2\text{J}_{\text{HF}}=43.2$ $^3\text{J}_{\text{HF}}=10.8$ $^3\text{J}_{\text{HF}}=4.8$		
		t			
	5.243	s			f
	5.827	d	$^3\text{J}_{\text{HH}}=8.0$	1	b
	7.275	d	$^3\text{J}_{\text{HH}}=7.6$	1	a
	9.051	br s		1	d
	^{13}C	67.620	d	$^2\text{J}_{\text{CF}}=34.4$	
d			$^2\text{J}_{\text{CF}}=26.8$		
73.798		s			f
83.666		d	$^1\text{J}_{\text{CF}}=195.3$		i
		t	$^2\text{J}_{\text{CF}}=35.1$		
		d	$^2\text{J}_{\text{CF}}=26.4$		
104.017		s			b
116.416		t	$^1\text{J}_{\text{CF}}=250.9$		h
		d	$^2\text{J}_{\text{CF}}=25.2$		
120.628		q	$^1\text{J}_{\text{CF}}=281.5$		j
		d	$^2\text{J}_{\text{CF}}=24.7$		
142.947		s			a
151.132	s			e	
163.159	s			c	
^{19}F	-69.746	d	$^3\text{J}_{\text{FH}}=10.5$	3	j
		d	$^3\text{J}_{\text{FF}}=10.5$		
		d	$^4\text{J}_{\text{FF}}=9.4$		
		d	$^4\text{J}_{\text{FF}}=5.6$		
	-112.119	AB	$^2\text{J}_{\text{FF}}=278.8$	1	h
		m			
-116.579	AB	$^2\text{J}_{\text{FF}}=287.1$	1	h	
	m				

-209.177

d ${}^2J_{FH}=42.9$
q ${}^3J_{FF}=6.4$
t ${}^3J_{FF}=2.6$

l

i

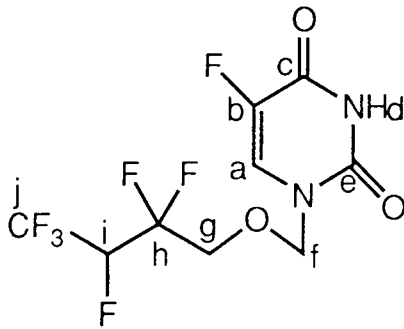
No. 41 5-Fluorouracylmethoxy-2,2,3,4,4,4-hexafluorobutane (199)

Chemical Shift/p.p.m.	Multiplicity	Coupling Constant/Hz	Relative Intensity	Assignment	
1H	3.815	AB	$^2J_{HH}=11.0$	1	g
		d	$^3J_{HF}=10.3$		
		d	$^3J_{HF}=2.5$		
	4.182	AB	$^2J_{HH}=11.0$	1	g
		d	$^3J_{HF}=7.0$		
		d	$^3J_{HF}=3.3$		
	4.984	d	$^2J_{HF}=43.25$	1	i
		d	$^3J_{HF}=21.0$		
		q	$^3J_{HF}=5.8$		
		d	$^3J_{HF}=0.8$		
5.551	s		2	f	
7.668	d	$^3J_{HF}=8.4$	1	a	
9.986	br s		1	d	
^{19}F	-74.527	s		3	e
	-116.948	AB	$^2J_{FF}=276.4$	1	c
		m			
	-121.636	AB	$^2J_{FF}=276.3$	1	c
		m			
	-167.344	m		1	b
-214.033	d	$^2J_{FH}=40.7$	1	d	
	m				

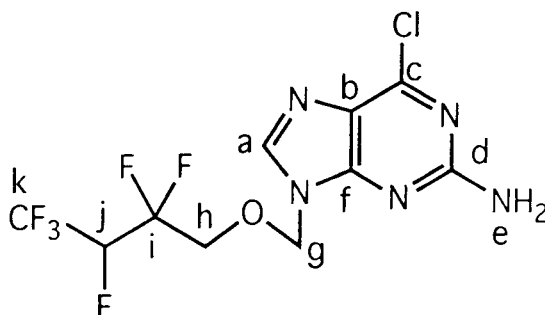
No. 42 2-Amino-6-chloropurinylmethoxy-2,2,3,4,4,4-hexafluorobutane (205)

Chemical Shift/p.p.m.	Multiplicity	Coupling Constant/Hz	Relative Intensity	Assignment	
¹ H	4.222 and 4.247	d	³ J _{HF} =23.2	2	h
		d	² J _{HH} =10.5		
		d	³ J _{HF} =10.5		
		d	⁴ J _{HF} =9.2		
		d	⁴ J _{HH} =3.2		
	5.642	d	² J _{HF} =42.0	1	j
		d	³ J _{HF} =16.8		
		d	³ J _{HF} =6.4		
		d	³ J _{HF} =4.8		
	5.727	br s		2	e
5.183	s		2	g	
8.183	s		1	a	
¹⁹ F	-74.495	s		3	k
	-117.749	AB	² J _{FF} =274.2	1	i
		m			
	-121.544	AB	² J _{FF} =273.7	1	i
		m			
-215.126	d	² J _{HF} =31.1	1	j	
	m				

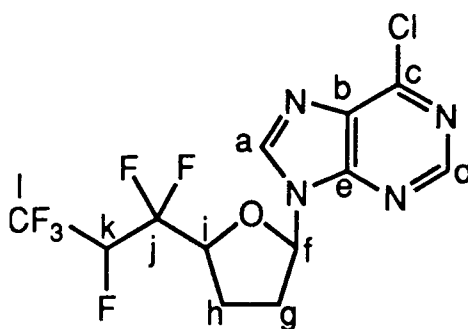
No. 43 2-(6-Chloropurinyl)-5-(1,1,2,3,3,3-hexafluoropropyl)oxolane (206)

	Chemical Shift/p.p.m.	Multiplicity	Coupling Constant/Hz	Relative Intensity	Assignment
^1H	2.499	m		1	g
	2.819	m		2	h
	2.845	m		1	g
	5.073	d	$^3J_{\text{HF}}=20.4$	1	i
		m			
	5.697	d	$^2J_{\text{HF}}=42.0$	1	k
		m			
	6.708	m		1	f
	8.693	s		1	a
	8.767	s		1	d
^{19}F	-74.248	s		3	l
	-125.500	AB	$^2J_{\text{FF}}=267.1$	1	j
		m			
	-129.351	AB	$^2J_{\text{FF}}=271.1$	1	j
		m			
	-214.032	d	$^2J_{\text{FH}}=31.1$	1	k
	m				

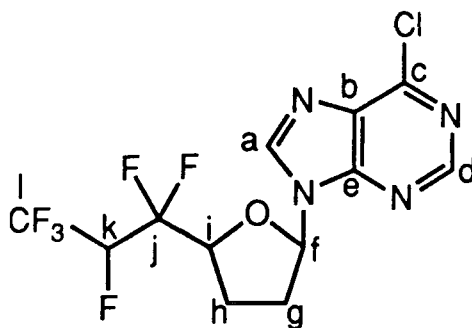
No. 43 2-(6-Chloropuriny)-5-(1,1,2,3,3,3-hexafluoropropyl)oxolane (206)

Chemical Shift/p.p.m.	Multiplicity	Coupling Constant/Hz	Relative Intensity	Assignment
<i>¹H</i>				
2.499	m		1	g
2.819	m		2	h
2.845	m		1	g
5.073	d	$^3J_{HF}=20.4$	1	i
	m			
5.697	d	$^2J_{HF}=42.0$	1	k
	m			
6.831	m		1	f
8.585	s		1	a
8.753	s		1	d
<i>¹⁹F</i>				
-74.692	s		3	l
-121.206	AB	$^2J_{FF}=267.3$	1	j
	m			
-124.421	AB	$^2J_{FF}=240.0$	1	j
	m			
-217.239	d	$^2J_{FH}=32.7$	1	k
	m			

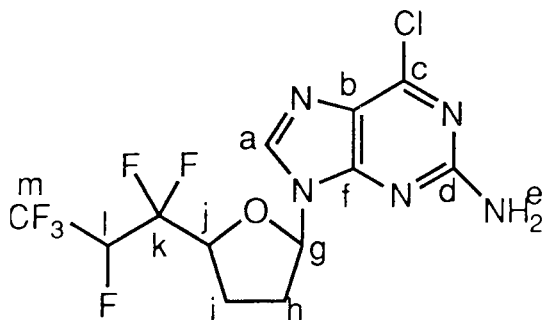
No. 44 2-(2-Amino-6-chloropuriny)-5-(1,1,2,3,3,3-hexafluoropropyl)oxolane (207)

Chemical Shift/p.p.m.	Multiplicity	Coupling Constant/Hz	Relative Intensity	Assignment
<i>¹H</i>				
2.143	m		1	h
2.402	m		2	i
2.679	m		1	h
4.653	t	$^3J_{HF}=9.5$	1	j
	m			
4.945	d	$^2J_{HF}=42.7$	1	l
	m			
5.332	br s (D ₂ O ex)		2	e
6.351	m		1	g
7.792	s		1	a
<i>¹⁹F</i>				
-75.117	m		3	m
-125.098	AB	$^2J_{FF}=272.5$	1	k
	m			
-131.704	AB	$^2J_{FF}=272.3$	1	k
	m			
-213.219	d	$^2J_{FH}=42.1$	1	l
	m			

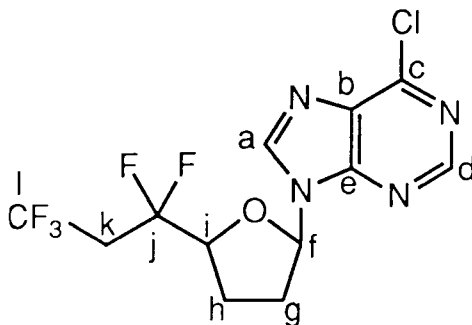
No. 45 2-(6-Chloropurinyl)-5-(1,1,3,3,3-pentafluoropropyl)oxolane (208)

Chemical Shift/p.p.m.	Multiplicity	Coupling Constant/Hz	Relative Intensity	Assignment
<i>¹H</i>				
2.406	m		1	g
2.744	m		2	h
2.823	m		1	g
3.198	d	³ J _{HF} =22.8	1	k
	d	³ J _{HF} =10.8		
	d	³ J _{HF} =1.2		
3.266	d	³ J _{HF} =10.4	1	k
	d	³ J _{HF} =10.4		
	d	³ J _{HF} =10.4		
4.869	t	³ J _{HF} =7.2	1	i
	d	³ J _{HH} =7.2		
	d	³ J _{HH} =6.6		
6.669	d	³ J _{HH} =6.0	1	f
	d	³ J _{HH} =3.6		
8.675	s		1	a
8.755	s		1	d
<i>¹⁹F</i>				
-61.279	s		3	l
-109.479	AB	² J _{FF} =254.9	1	j
	m			
-115.104	AB	² J _{FF} =255.1	1	j
	m			

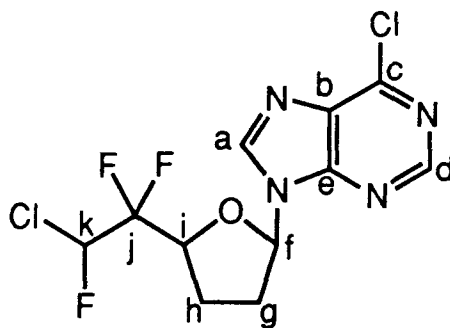
No. 46 2-(2-Chloro-1,1,2-trifluoroethyl)-5-(6-chloropurinyloxy)oxolane (α) (209)

Chemical Shift/p.p.m.	Multiplicity	Coupling Constant/Hz	Relative Intensity	Assignment
<i>¹H</i>				
2.464	m		2	g
2.664	m		2	h
4.601	d	$^3J_{HF}=15.5$	1	i
	t	$^3J_{HH}=8.7$		
6.184	d	$^2J_{HF}=44.6$	1	k
	m			
6.372	t	$^3J_{HH}=4.9$	1	f
8.124	s		1	d
8.196 or 8.230	s		1	a
<i>¹⁹F</i>				
-126.094	m		2	j
-153.135	d	$^2J_{FH}=47.8$	1	k
	m			

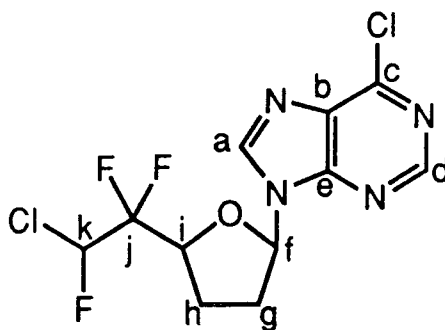
No. 46 2-(2-Chloro-1,1,2-trifluoroethyl)-5-(6-chloropurinyloxy)oxolane (α) (209)

Chemical Shift/p.p.m.	Multiplicity	Coupling Constant/Hz	Relative Intensity	Assignment
<i>¹H</i>				
2.464	m		2	g
2.664	m		2	h
4.601	d	$^3J_{\text{HF}}=15.5$	1	i
	t	$^3J_{\text{HH}}=8.7$		
6.184	d	$^2J_{\text{HF}}=44.6$	1	k
	m			
6.372	t	$^3J_{\text{HH}}=4.9$	1	f
8.124	s		1	d
8.196 or 8.230	s		1	a
<i>¹⁹F</i>				
-127.507	m		2	j
-159.428	d	$^2J_{\text{FH}}=48.2$	1	k
	t	$^3J_{\text{FF}}=13.2$		

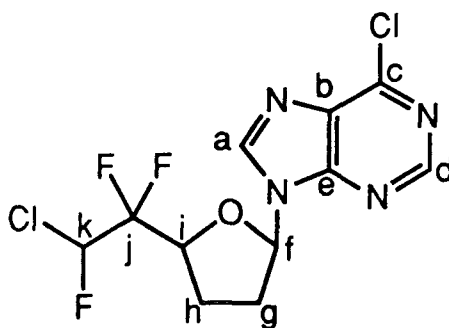
No. 46 2-(2-Chloro-1,1,2-trifluoroethyl)-5-(6-chloropurinyl)oxolane (β) (209)

Chemical Shift/p.p.m.	Multiplicity	Coupling Constant/Hz	Relative Intensity	Assignment
<i>¹H</i>				
2.599	m		2	g
2.664	m		2	h
4.883	m		1	i
6.184	d	$^2J_{HF}=44.6$	1	k
	m			
6.437	t	$^3J_{HH}=5.3$	1	f
8.124	s		1	d
8.196 or 8.230	s		1	a
<i>¹⁹F</i>				
-125.819	m		2	j
-160.813	d	$^2J_{FH}=49.2$	1	k
	t	$^3J_{FF}=13.6$		

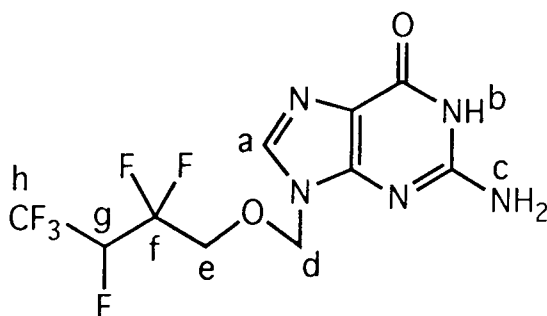
No.47 Guanylmethoxy-1,1,2,3,3,3-hexafluorobutane (210)

Chemical Shift/p.p.m.	Multiplicity	Coupling Constant/Hz	Relative Intensity	Assignment	
1H	4.222 and 4.247	d d d d d	2	e	
	5.199	s	2	d	
	5.633	d d m	1	g	
	6.522	br s (D ₂ O ex)	2	c	
	7.656	s	1	a	
	10.450	br s (D ₂ O ex)	1	b	
	^{19}F	-74.948	d d d d	3	k
		-118.246	AB d q d	1	i
		-121.920	AB d q d	1	i
		-215.566	d m	1	j

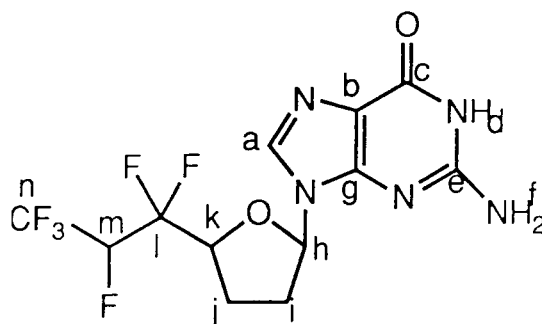
No.48 2-(1,1,2,3,3,3-Hexafluoropropyl)-5-guanyloxolane (211)

Chemical Shift/p.p.m.	Multiplicity	Coupling Constant/Hz	Relative Intensity	Assignment
<i>¹H</i>				
2.144	m		1	i
2.437	m		2	j
2.653	m		1	i
4.653	m		1	k
5.005	d	$^2J_{HF}=42.3$	1	m
	m			
6.522	br s (D ₂ O ex)		2	f
6.651	m		1	g
7.692	s		1	a
10.670	br s (D ₂ O ex)		1	d
<i>¹⁹F</i>				
-74.896	s		3	n
-125.644	AB	$^2J_{FF}=276.5$	1	l
	m			
-131.449	AB	$^2J_{FF}=281.7$	1	l
	m			
-213.303	d	$^2J_{FH}=37.7$	1	m
	m			

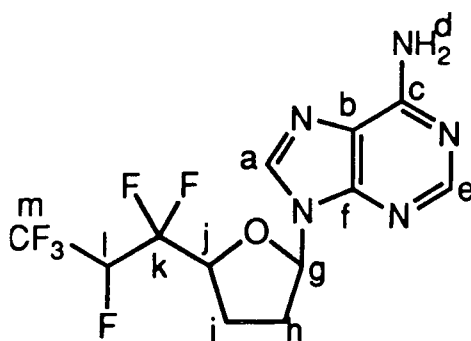
No.49 2-Adenyl-5-(1,1,2,3,3,3-hexafluoropropyl)oxolane (212)

Chemical Shift/p.p.m.	Multiplicity	Coupling Constant/Hz	Relative Intensity	Assignment
<i>¹H</i>				
2.278	m		1	h
2.618	m		2	i
2.685	m		1	h
4.880	m		1	j
6.167	d	$^2J_{HF}=42.0$	1	l
6.445	t	$^3J_{HH}=3.2$	1	g
7.411	br s(D ₂ O ex)		2	d
8.180	s		1	a or e
8.353	s		1	e or a
<i>¹⁹F</i>				
-74.702	d	$^3J_{FF}=10.9$	3	m
	d	$^3J_{FH}=10.9$		
	d	$^3J_{FF}=10.9$		
	d	$^4J_{FF}=6.0$		
-125.978	AB	$^2J_{FF}=269.8$	1	k
	d	$^3J_{FH}=11.3$		
	d	$^3J_{FF}=11.3$		
	q	$^4J_{FF}=11.3$		
-129.704	AB	$^2J_{FF}=269.8$	1	k
	d	$^3J_{FF}=12.0$		
	d	$^3J_{FH}=12.0$		
	d	$^3J_{FH}=12.0$		
	t	$^4J_{FF}=4.1$		
-214.475	d	$^1J_{FH}=41.4$	1	l
	q	$^3J_{FF}=10.2$		
	t	$^3J_{FF}=3.8$		

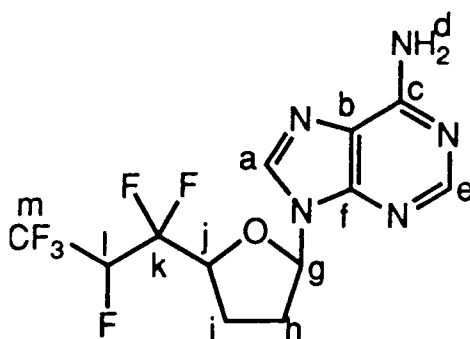
No.49 2-Adenyl-5-(1,1,2,3,3,3-hexafluoropropyl)oxolane (212)

Chemical Shift/p.p.m.	Multiplicity	Coupling Constant/Hz	Relative Intensity	Assignment
<i>¹H</i>				
2.359	m		1	h
2.618	m		2	i
2.685	m		1	h
4.583	m		1	j
6.030	d	$^2J_{HF}=41.6$	1	l
6.460	m		1	
6.460	t	$^3J_{HH}=3.2$	1	g
7.383	br s(D ₂ O ex)		2	d
8.180	s		1	a or e
8.345	s		1	e or a
<i>¹⁹F</i>				
-75.122	d	$^3J_{FF}=11.3$	3	m
	d	$^3J_{FH}=11.3$		
	d	$^3J_{FF}=11.3$		
	d	$^4J_{FF}=5.3$		
-121.689	AB	$^2J_{FF}=270.5$	1	k
	d	$^3J_{FH}=9.0$		
	d	$^3J_{FF}=9.0$		
	q	$^4J_{FF}=9.0$		
-129.704	AB	$^2J_{FF}=270.5$	1	k
	d	$^3J_{FF}=8.3$		
	d	$^3J_{FH}=8.3$		
	d	$^3J_{FH}=8.3$		
	d	$^4J_{FF}=8.3$		
	t	$^4J_{FF}=3.8$		
-217.702	d	$^1J_{FH}=42.5$	1	l
	t	$^3J_{FF}=10.9$		
	d	$^3J_{FF}=8.3$		

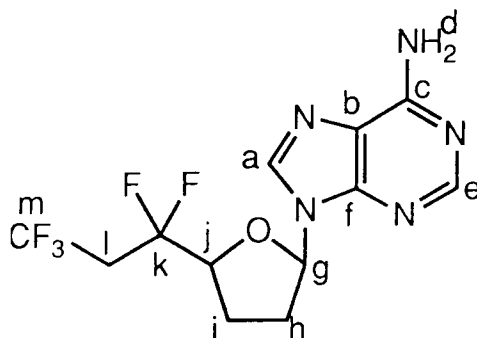
No.50 2-Adenyl-5-(1,1,3,3,3-pentafluoropropyl)oxolane (213)

Chemical Shift/p.p.m.	Multiplicity	Coupling Constant/Hz	Relative Intensity	Assignment
<i>¹H</i>				
2.200	t	$^3J_{HH}=7.2$	1	h
2.549	m		2	i
2.120	m		1	h
3.290	m		2	l
4.675	d	$^3J_{HH}=12.4$	1	j
	d	$^3J_{HH}=6.4$		
	t	$^3J_{HF}=6.4$		
6.417	d	$^3J_{HH}=7.2$	1	g
	d	$^3J_{HH}=4.4$		
6.870	br s(D ₂ O ex)		2	k
7.959	s		0.5	l or n
8.001	s		0.5	l or n
8.026	s		1	l or n
<i>¹⁹F</i>				
-65.920	t	$^4J_{FF}=9.4$	3	m
	t	$^3J_{FH}=9.4$		
-114.143	AB	$^2J_{FF}=263.0$	1	k
	t	$^3J_{FH}=18.4$		
	q	$^3J_{FF}=9.4$		
	d	$^3J_{FH}=3.8$		
-119.702	AB	$^2J_{FF}=263.4$	1	k
	t	$^3J_{FH}=19.6$		
	q	$^3J_{FF}=9.4$		

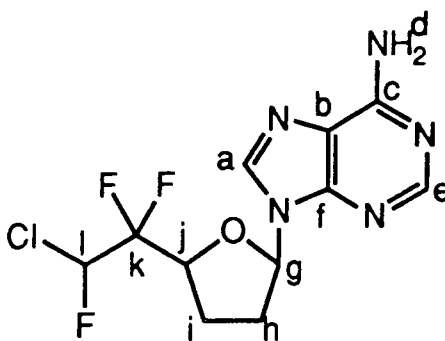
No. 51 2-Adenyl-5-(2-chloro-1,1,2-trifluoroethyl)oxolane (α) (214)

Chemical Shift/p.p.m.	Multiplicity	Coupling Constant/Hz	Relative Intensity	Assignment
<i>¹H</i>				
2.364	m		1	h
2.620	m		2	i
2.668	m		1	h
4.606	m		1	j
6.351	m		1	g
7.000	d	$^2J_{HF}=46.1$	1	l
	m			
7.376	br s (D ₂ O ex)		2	d
8.167	s		1	a or e
8.262	s		1	e or a
<i>¹⁹F</i>				
-125.996	m		2	k
-153.133	d	$^2J_{FH}=46.8$	1	l
	m			

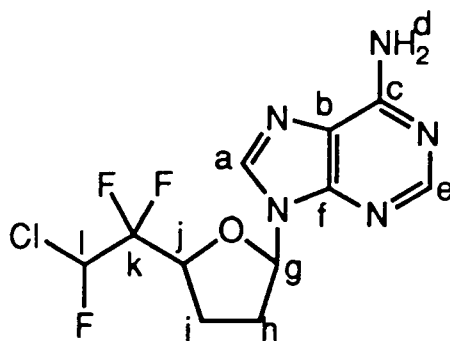
No. 51 2-Adenyl-5-(2-chloro-1,1,2-trifluoroethyl)oxolane (α) (214)

Chemical Shift/p.p.m.	Multiplicity	Coupling Constant/Hz	Relative Intensity	Assignment
<i>¹H</i>				
2.364	m		1	h
2.620	m		2	i
2.668	m		1	h
4.944	m		1	j
6.351	m		1	g
7.091	d	$^2J_{HF}=47.3$	1	l
	m			
7.376	br s (D ₂ O ex)		2	d
8.167	s		1	a or e
8.341 or	s		1	e or a
8.334				
<i>¹⁹F</i>				
-127.511	m		2	k
-159.443	d	$^2J_{FH}=47.2$	1	l
	t	$^3J_{FF}=13.0$		

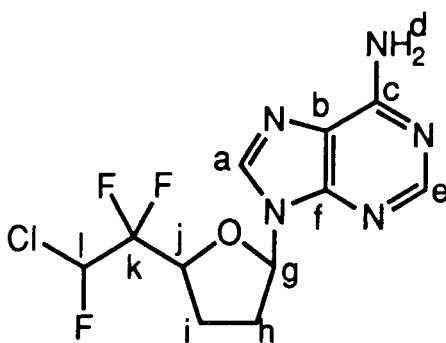
No. 51 2-Adenyl-5-(2-chloro-1,1,2-trifluoroethyl)oxolane (β) (214)

Chemical Shift/p.p.m.	Multiplicity	Coupling Constant/Hz	Relative Intensity	Assignment
<i>¹H</i>				
2.260	m		1	h
2.620	m		2	i
2.668	m		1	h
4.944	m		1	j
6.433	m		1	g
7.091	d	$^2J_{HF}=47.3$	1	l
	m			
7.376	br s (D ₂ O ex)		2	d
8.167	s		1	a or e
8.341 or	s		1	e or a
8.334				
<i>¹⁹F</i>				
-125.812	m		2	j
-160.793	d	$^2J_{FH}=47.2$	1	k
	t	$^3J_{FF}=13.6$		

No. 52 2-(1,1,3,3,3-Pentafluoropropyl)-5-(5-fluoro-5,6-dihydro-6-hydroxyuracyl)oxolane (trans)(202)

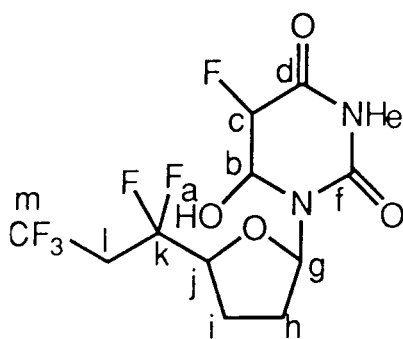

Chemical Shift/p.p.m.	Multiplicity	Coupling Constant/Hz	Relative Intensity	Assignment
<i>¹H</i>				
1.518	m		3	h,i
2.636	t	$^3J_{HH}=7.0$	1	h
3.128	m		2	l
4.248	t	$^3J_{HF}=22.8$	1	j
	d	$^3J_{HH}=2.3$		
5.071	d	$^2J_{HF}=49.0$	1	c
	d	$^3J_{HH}=3.3$		
5.231	d	$^3J_{HF}=5.1$	1	b
	d	$^3J_{HH}=3.3$		
5.692	t	$^3J_{HH}=8.0$	1	g
9.426	br s (D ₂ O ex)		1	e
<i>¹⁹F</i>				
-61.836	s		3	m
-113.662	AB	$^2J_{FF}=274.6$	1	k
	m			
-131.101	AB	$^2J_{FF}=274.9$	1	k
	m			
-148.950	s) 1	c (cis or trans)
-150.839	s)

No. 52 2-(1,1,3,3,3-Pentafluoropropyl)-5-(5-fluoro-5,6-dihydro-6-hydroxyuradyl)oxolane (cis)(202)

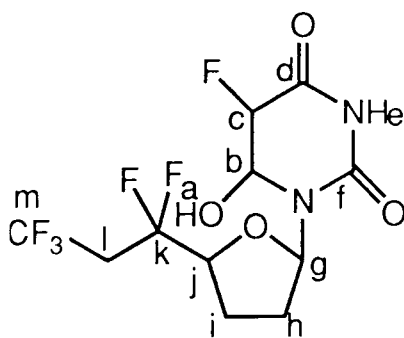

Chemical Shift/p.p.m.	Multiplicity	Coupling Constant/Hz	Relative Intensity	Assignment
<i>¹H</i>				
1.518	m		3	h,i
2.868	t	$^3J_{HH}=7.0$	1	h
3.128	m		2	l
4.248	t	$^3J_{HF}=22.8$	1	j
	d	$^3J_{HH}=2.3$		
5.375	d	$^2J_{HF}=49.0$	1	c
	d	$^3J_{HH}=3.3$		
5.231	d	$^3J_{HF}=3.3$	1	b
	d	$^3J_{HH}=3.3$		
5.692	t	$^3J_{HH}=8.0$	1	g
9.426	br s (D ₂ O ex)		1	e
<i>¹⁹F</i>				
-61.836	s		3	m
-113.662	AB	$^2J_{FF}=274.6$	1	k
	m			
-131.101	AB	$^2J_{FF}=274.9$	1	k
	m			
-148.950	s) 1	c (cis or trans)
-150.839	s)

Appendix Two

Infra Red Spectra

- No. 1 3-(Diethoxyphosphinyl)difluoromethylcyclopentene (106)
- No. 2 3-(Diethoxyphosphinyl)difluoromethylcyclohexene (107)
- No. 3 3-(Diethoxyphosphinyl)difluoromethylcycloheptene (108)
- No. 4 1-Methyl-(diethoxyphosphinyl)-2,2-difluoroethylbenzene (120)
- No. 5 1-(Diethoxyphosphinyl)difluoromethyl-2,3-epoxycyclohexene (127)
- No. 6 3-(Diethoxyphosphinyl)difluoromethylcyclohexen-6-ol (141)
- No. 7 3-Bromo-6-(diethoxyphosphinyl)difluoromethylcyclohexene (142)
- No. 8 3-[N9-(6-chloropuriny)]-6-(diethoxyphosphinyl)difluoromethylcyclohexene (145)
- No. 9 3-(N9-Adenyl)-6-(diethoxyphosphinyl)difluoromethylcyclohexene (147)
- No. 10 3-(N9-Adenyl)-6-(dihydroxyphosphinyl)difluoromethylcyclohexene (139)
- No. 11 3-[N9-(2-amino-6-chloropuriny)]-6-(diethoxyphosphinyl)difluoromethylcyclohexene (149)
- No. 12 3-(Ethoxyhydroxyphosphinyl)difluoromethyl-6-(N9-guanyl)cyclohexene (151)
- No. 13 3-(N9-Guanyl)-6-(dihydroxyoxyphosphinyl)difluoromethylcyclohexene (140)
- No. 14 1-Bromo-2-(diethoxyphosphinyl)difluoromethylcyclohexane (153)
- No. 15 [Bis(trimethylsiloxy)phosphinyl]bromodifluoromethane (155)
- No. 16 (Dihydroxyphosphinyl)bromodifluoromethane (154)
- No. 17 1-Bromo-2-(dihydroxyphosphinyl)difluoromethylcyclohexane (156)
- No. 18 1-(Diethoxyphosphinyl)difluoromethyl-2-iodocyclohexane (159)
- No. 19 1-(Diethoxyphosphinyl)difluoromethyl-2-iodocyclopentane (160)
- No. 20 1-(Diethoxyphosphinyl)difluoromethyl-2-iodocycloheptane (161)
- No. 21 Methoxy-2,2,4,4,4-pentafluorobutane (174)
- No. 22 Oligmers based on methoxy-4,4,4-trifluorobutane (175)
- No. 23 2-(1,1,3,3,3-Pentafluoropropyl)oxolane (177)
- No. 24 2-Chloro-5-(1,1,2,3,3,3-hexafluoropropyl)oxolane (186)
- No. 25 2-Chloro-5-(1,1,3,3,3-pentafluoropropyl)oxolane (187)
- No. 26 2-Chloro-5-(2-chloro-1,1,2-trifluoroethyl)oxolane (188)
- No. 27 2-(1,1,2,3,3,3-hexafluoropropyl)-4,5-dihydrofuran (189)
- No. 28 2-(2-Chloro-1,1,2-trifluoroethyl)-5-uradyloxolane (192)
- No. 29 2-(2-Chloro-1,1,2-trifluoroethyl)-5-(5-fluorouradyl)oxolane (193)
- No. 30 2-(1,1,3,3,3-Pentafluoropropyl)-5-uradyloxolane (194)

- No. 31 2-(1,1,3,3,3-Pentafluoropropyl)-5-(5-fluorouradyl)oxolane (195)
- No. 32 2-(1,1,2,3,3,3-Hexafluoropropyl)-5-uradyloxolane (196)
- No. 33 2-(1,1,2,3,3,3-Hexafluoropropyl)-5-(5-fluorouradyl)oxolane (197)
- No. 34 Uradylmethoxy-2,2,3,4,4,4-hexafluorobutane (198)
- No. 35 5-Fluorouradylmethoxy-2,2,3,4,4,4-hexafluorobutane (199)
- No. 36 2-Amino-6-chloropurinylmethoxy-2,2,3,4,4,4-hexafluorobutane (205)
- No. 37 2-(6-Chloropurinyl)-5-(1,1,2,3,3,3-hexafluoropropyl)oxolane (206)
- No. 38 2-(2-Amino-6-chloropurinyl)-5-(1,1,2,3,3,3-hexafluoropropyl)-oxolane (207)
- No. 39 2-(6-Chloropurinyl)-5-(1,1,3,3,3-pentafluoropropyl)oxolane (208)
- No. 40 2-(2-Chloro-1,1,2-trifluoroethyl)-5-(6-chloropurinyl)oxolane (209)
- No. 41 Guanylmethoxy-1,1,2,3,3,3-hexafluorobutane (210)
- No. 42 2-(1,1,2,3,3,3-Hexafluoropropyl)-5-guanyloxolane (211)
- No. 43 2-Adenyl-5-(1,1,2,3,3,3-hexafluoropropyl)oxolane (212)
- No. 44 2-Adenyl-5-(1,1,3,3,3-pentafluoropropyl)oxolane (213)
- No. 45 2-Adenyl-5-(2-chloro-1,1,2-trifluoroethyl)oxolane (214)
- No. 46 2-(1,1,3,3,3-Pentafluoropropyl)-5-(5-fluoro-5,6-dihydro-6-hydroxyuradyl)oxolane (202)

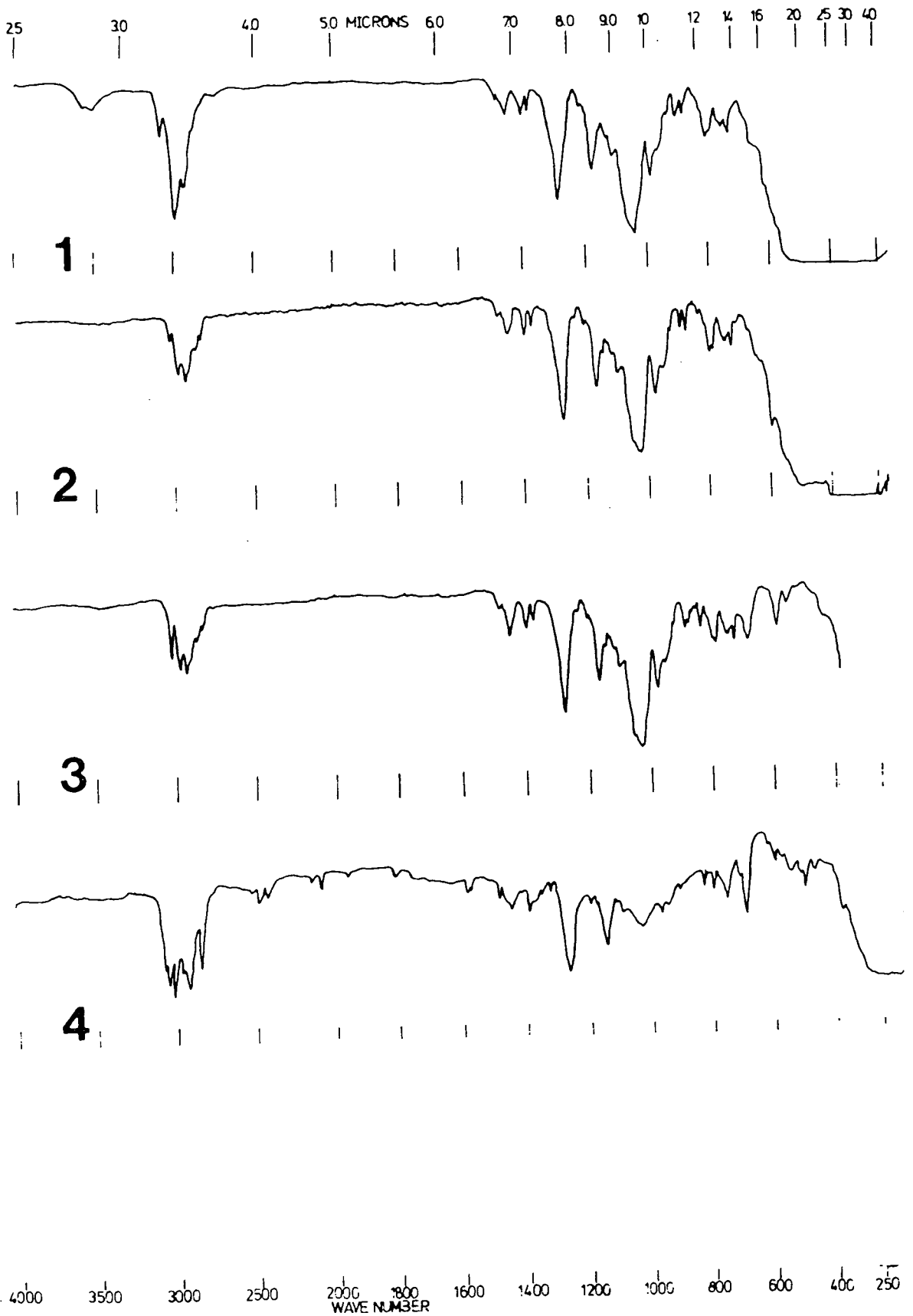

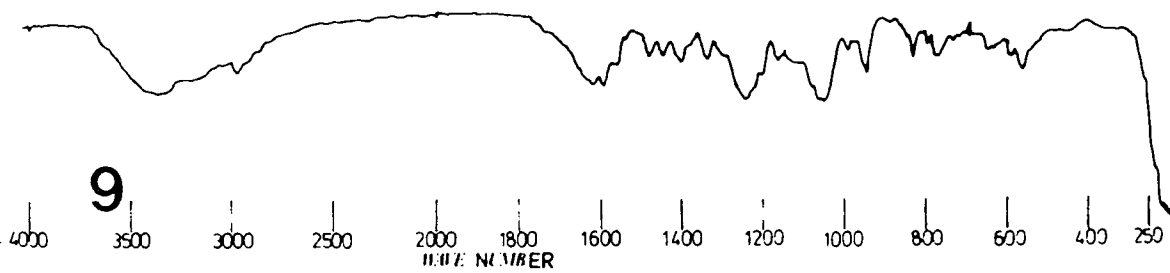
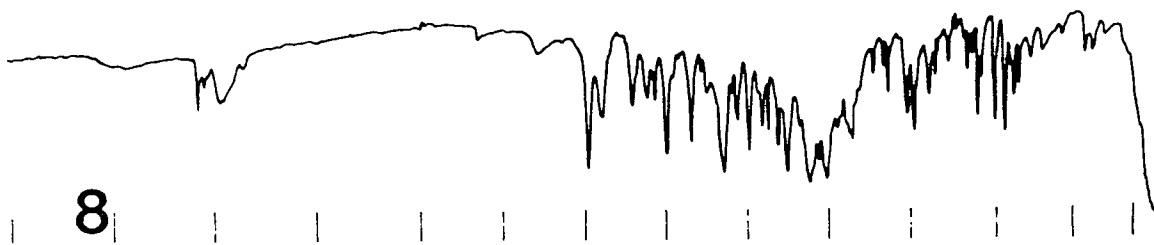
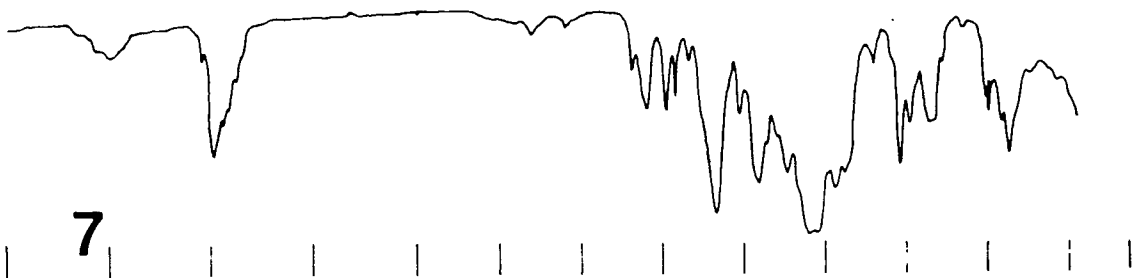
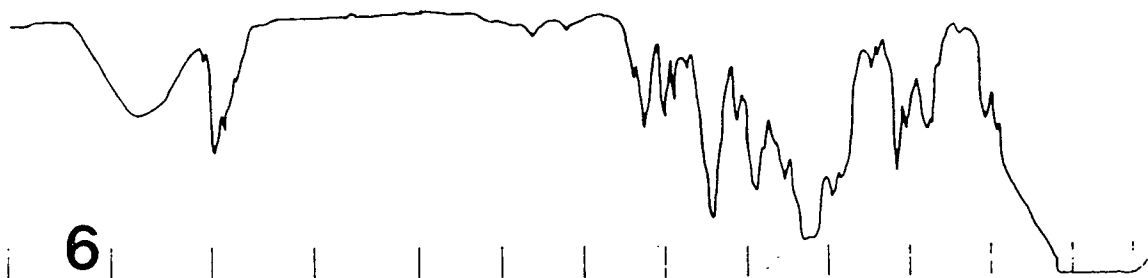
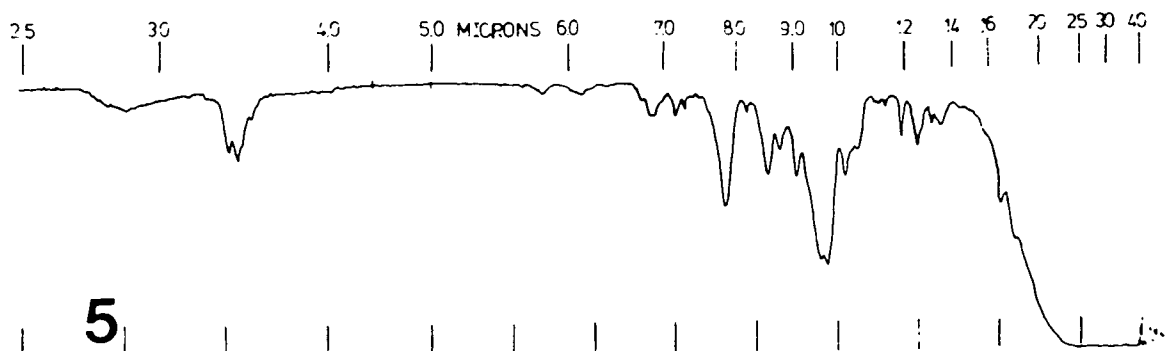

25 30 4.0 5.0 MICRONS 6.0 7.0 8.0 9.0 10 12 14 16 20 25 30 40

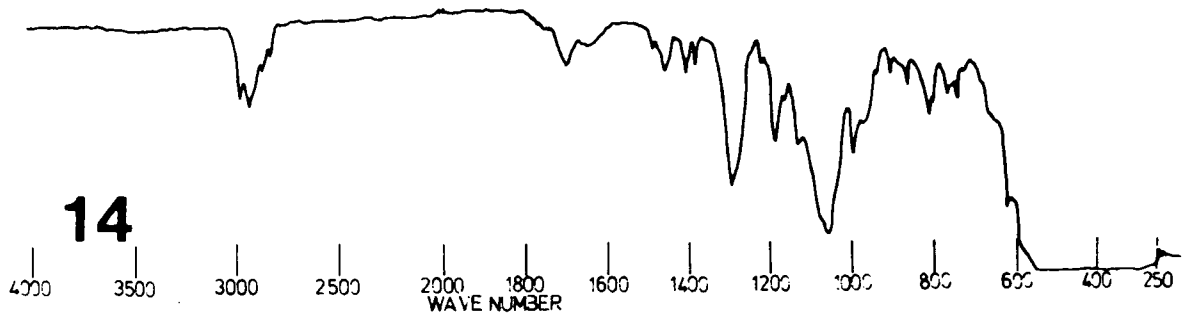
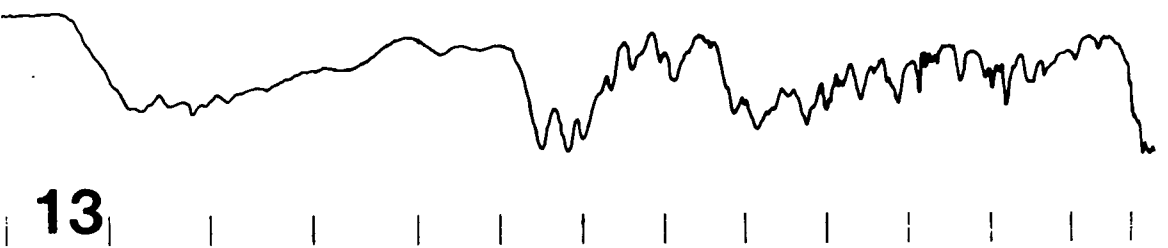
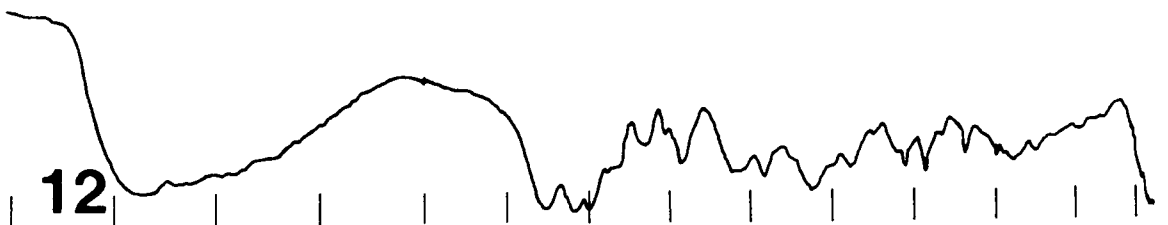
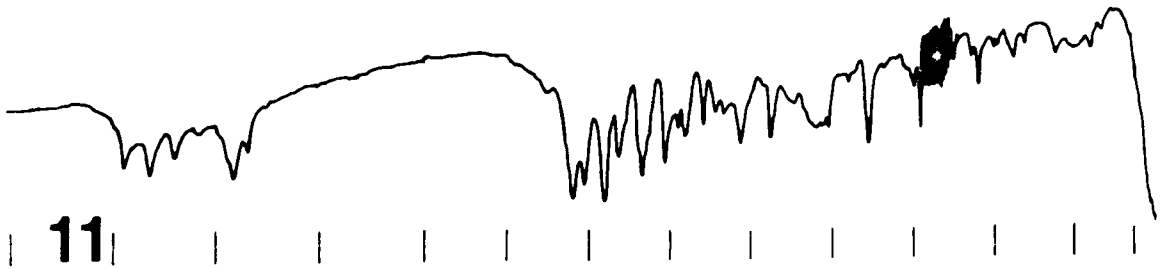
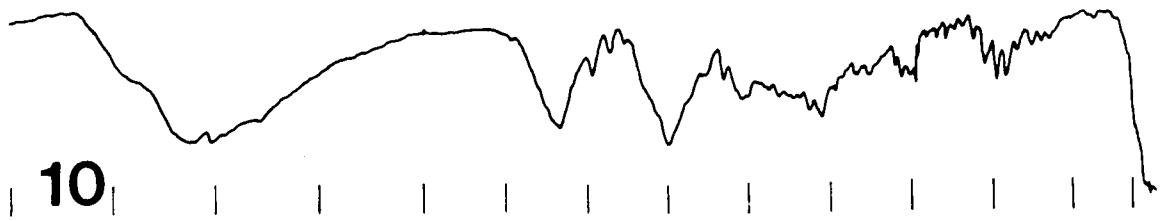

25 30 40 50 *WAVELENGTHS* 60 70 80 90 10 12 14 16 20 25 30 40

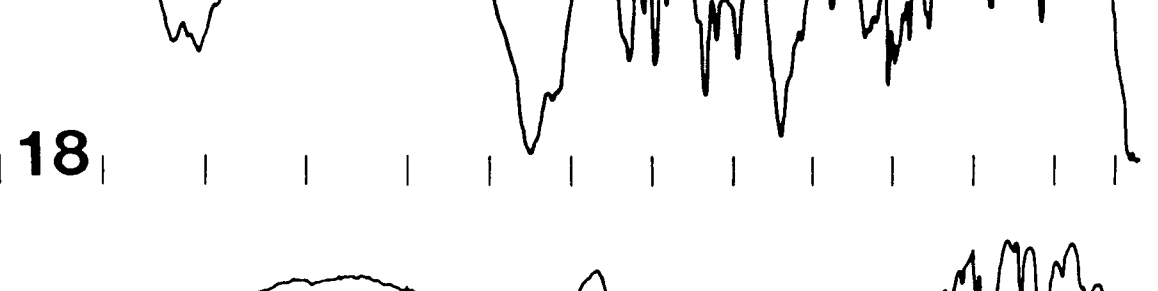
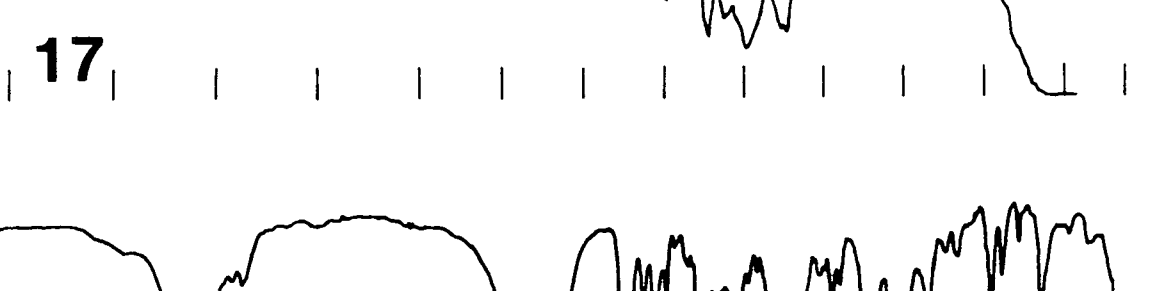
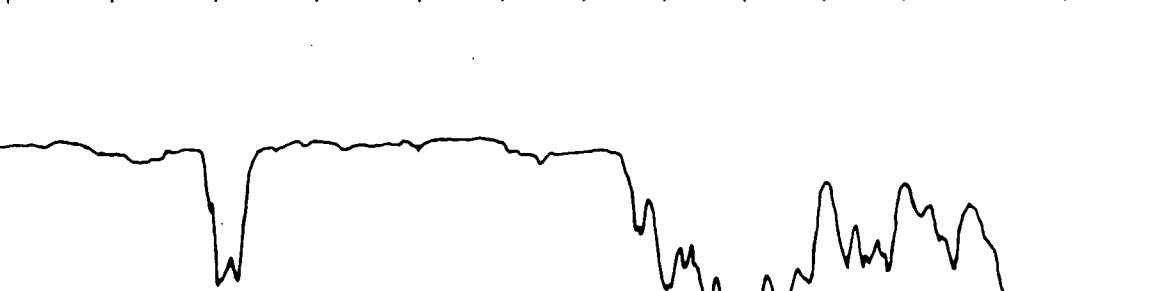
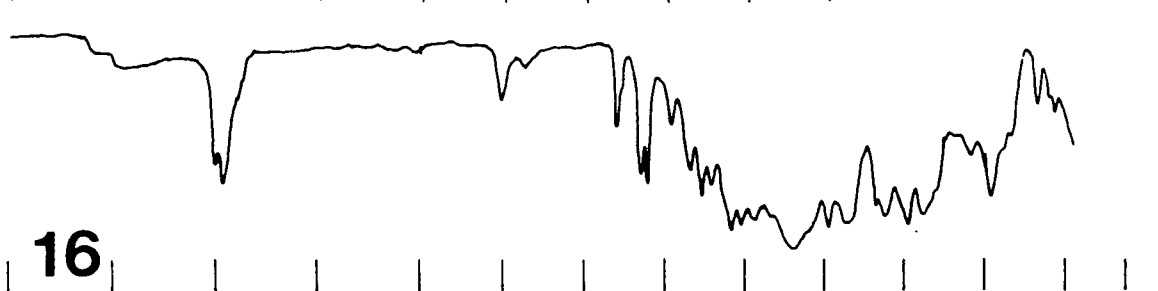

4000 3500 3000 2500 2000 1800 1600 1400 1200 1000 800 600 400 250
WAVE NUMBER

2.5 30 40 50 *WAVELENGTHS* 60 70 80 90 10 12 14 16 20 25 30 40

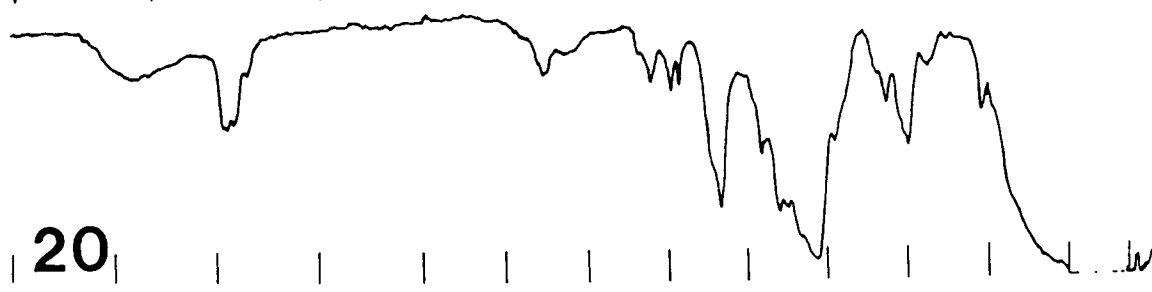

20

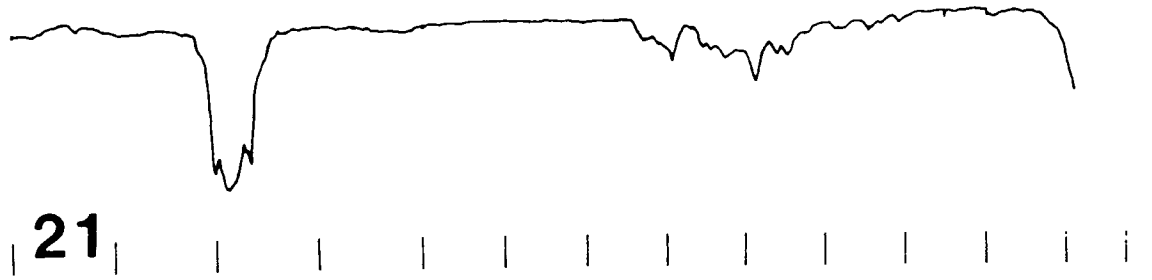

21



22

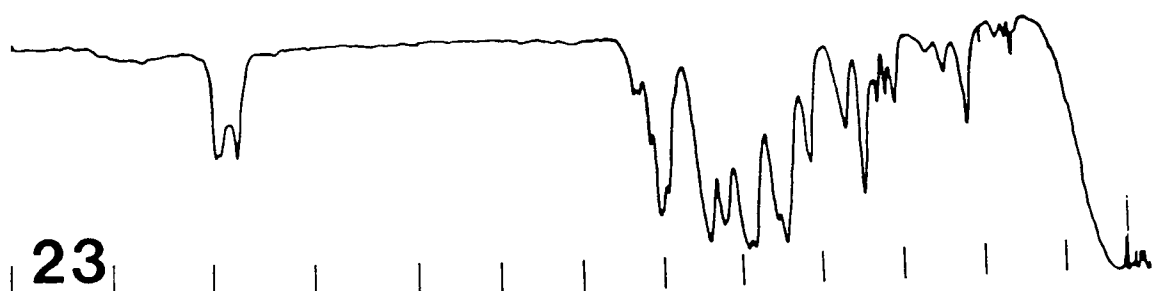

23

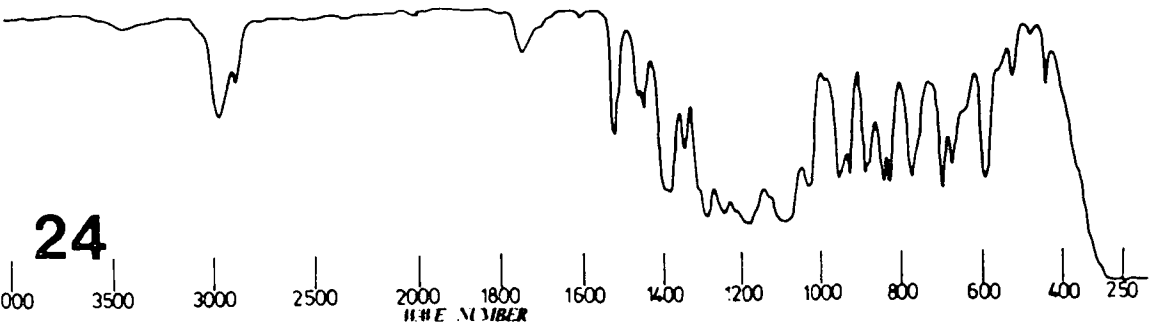

24

4000 3500 3000 2500 2000 1800 1600 1400 1200 1000 800 600 400 250
WAVE NUMBER

25 30 40 50 MICRONS 60 70 80 90 10 12 14 16 20 25 30 40

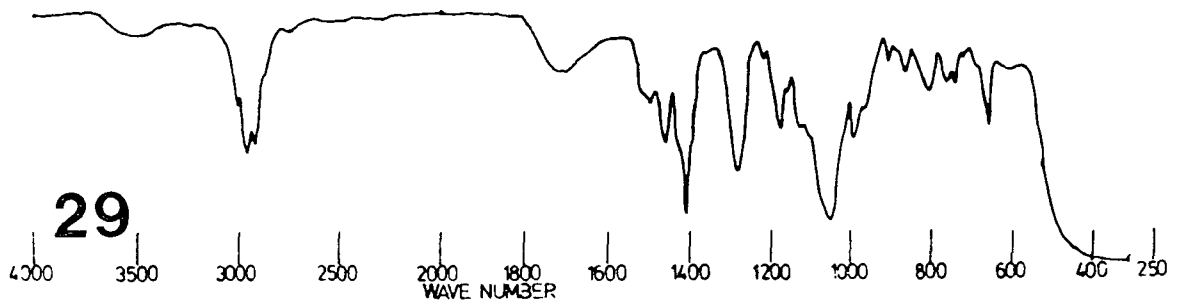
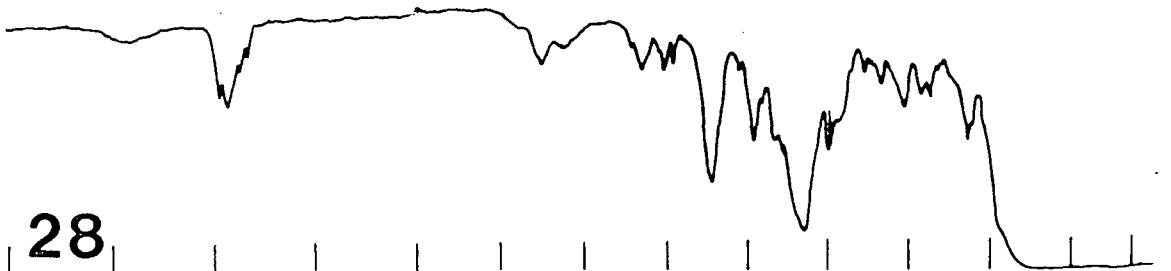
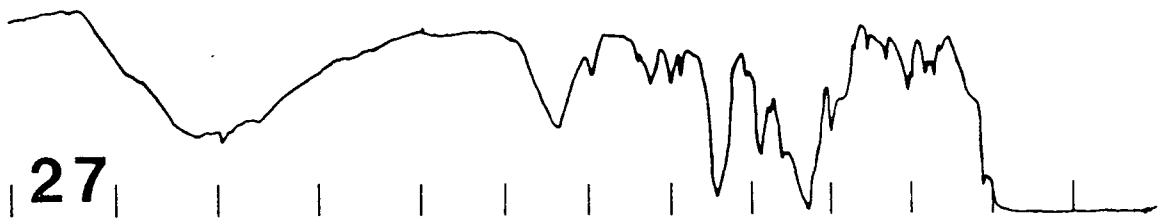
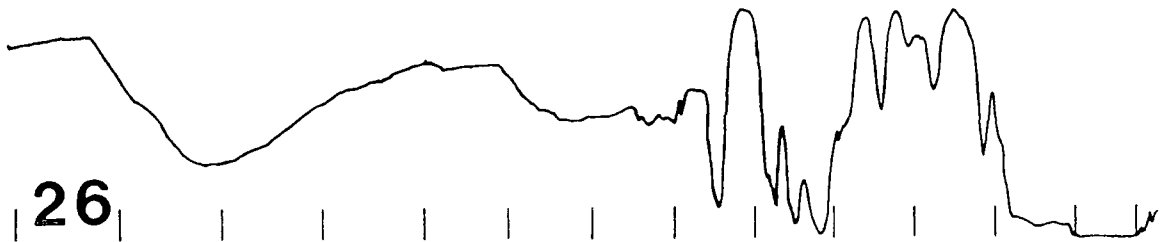
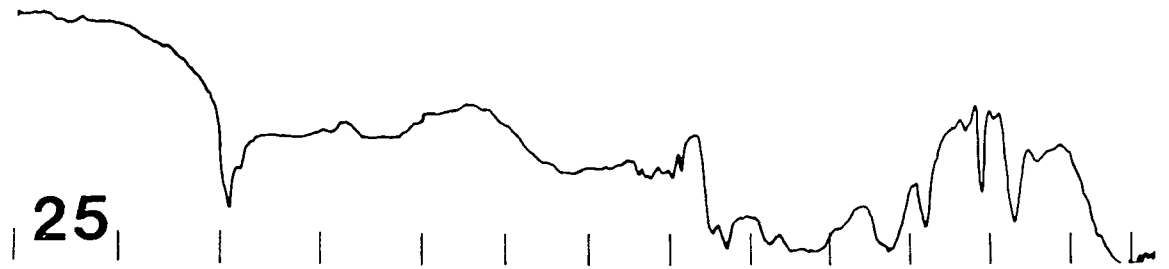

25 30 40 50 MICRONS 60 70 80 90 10 12 14 16 20 25 30 40



30



31

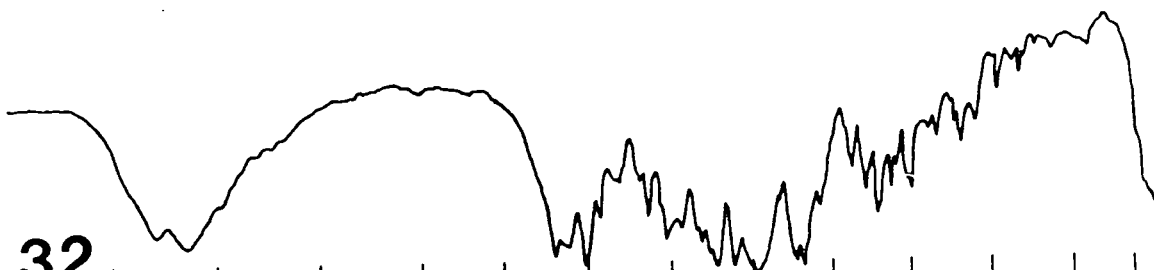

32

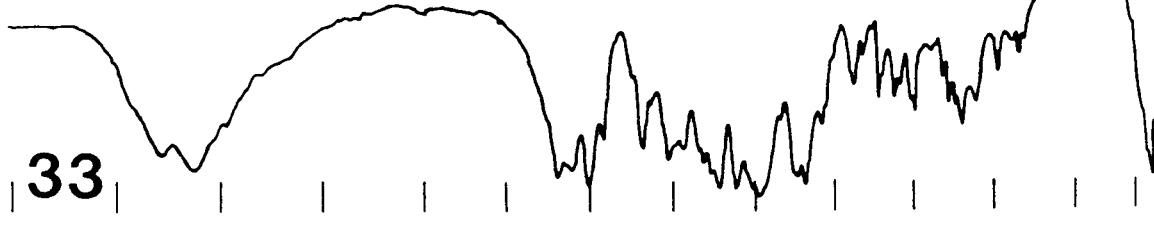

33

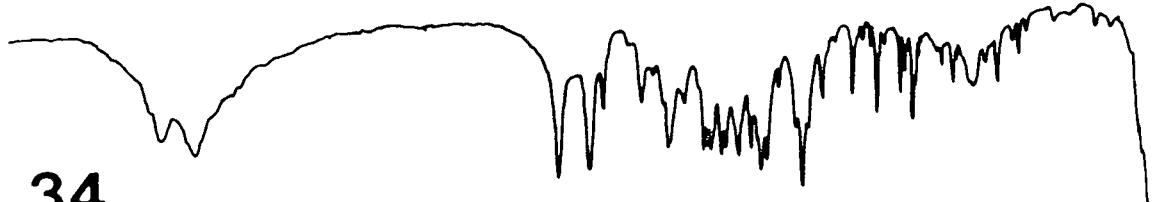

34

4000 3500 3000 2500 2000 1800 1600 1400 1200 1000 800 600 400 250
WAVE NUMBER

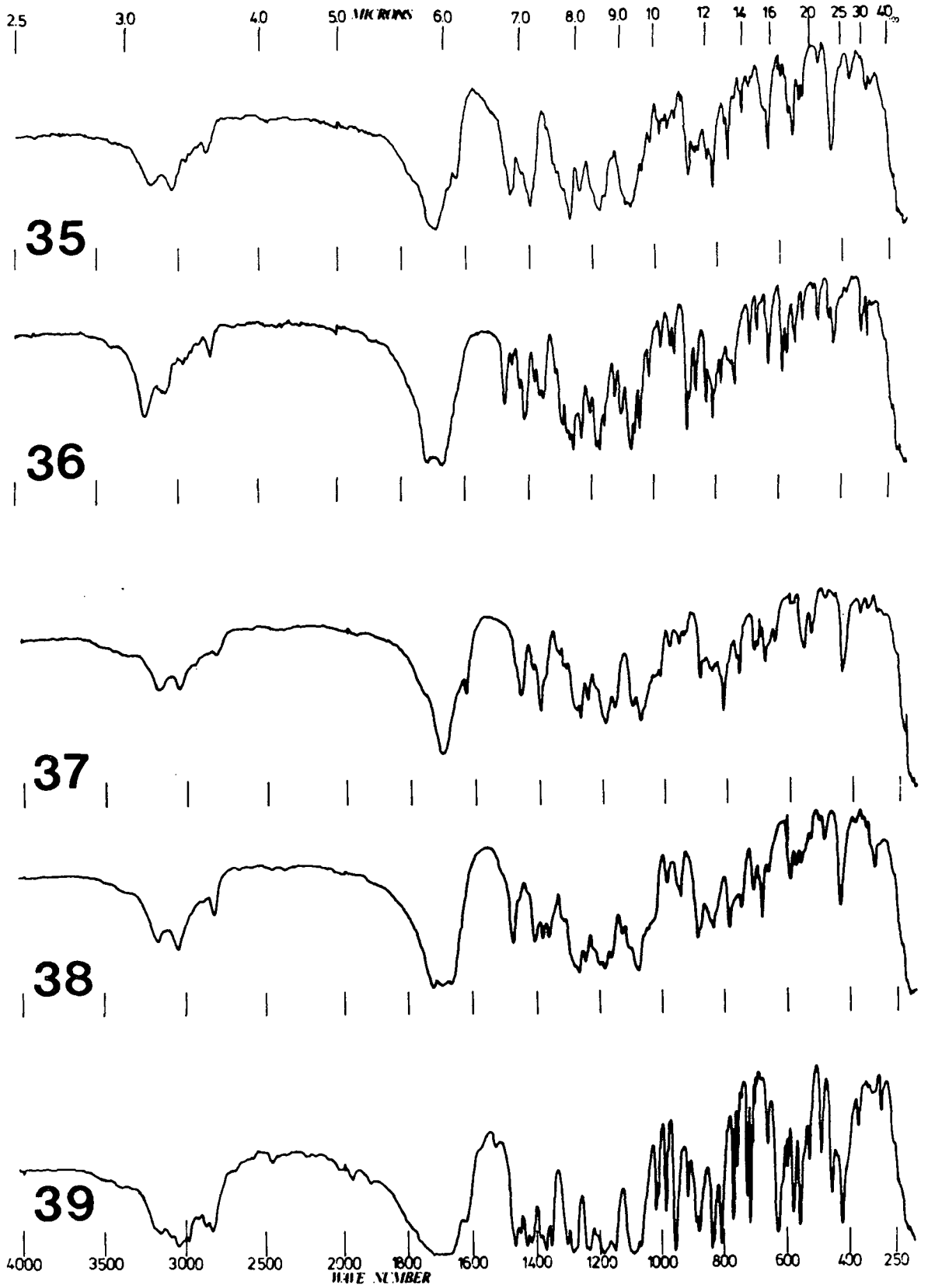

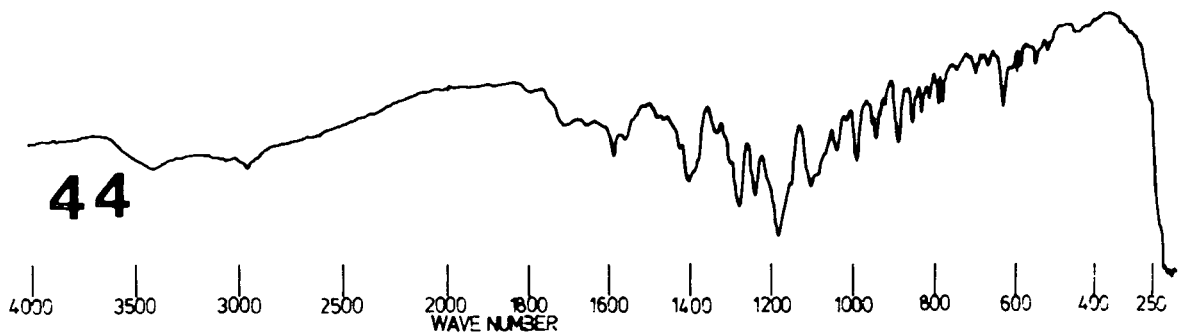
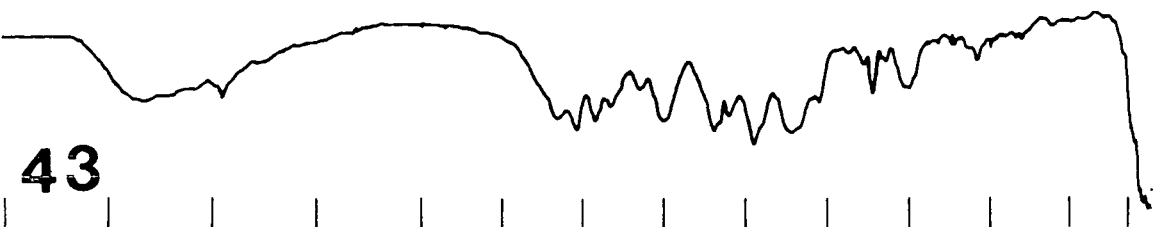
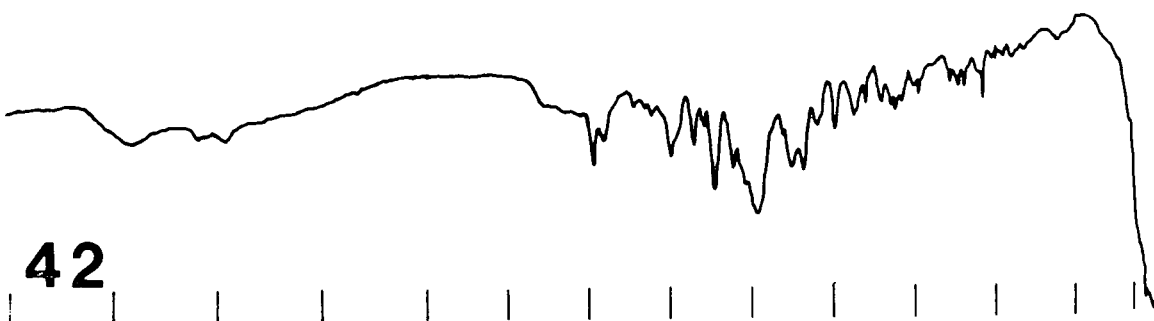
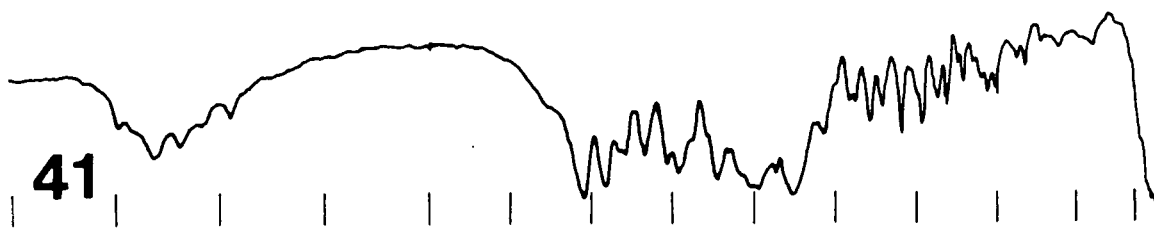
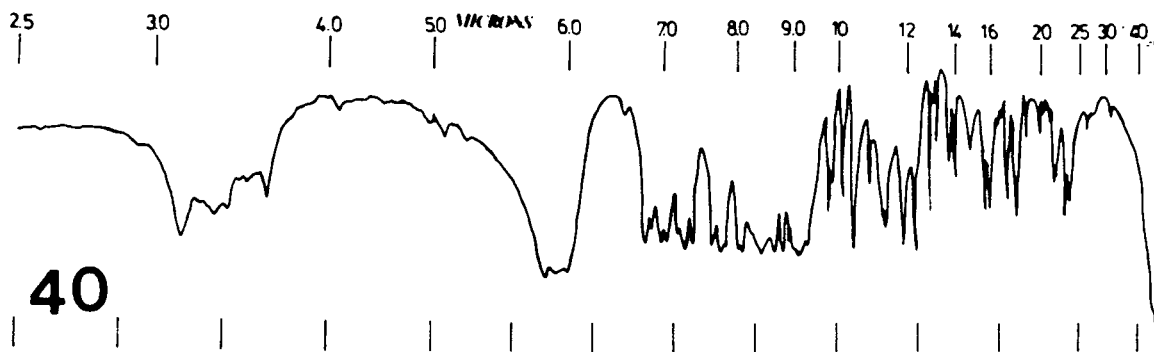

25 30 40 50 MICRONS 60 70 80 90 10 12 14 16 20 25 30 40

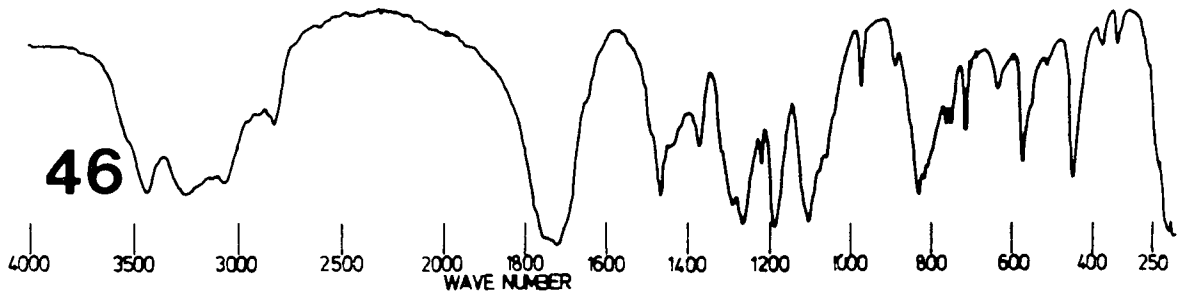
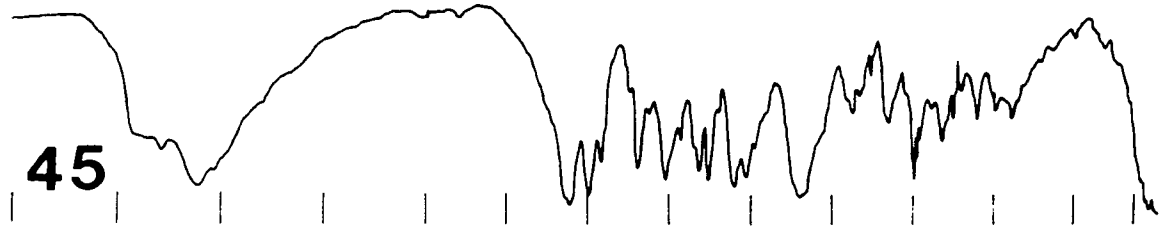

Appendix Three

Mass Spectra

- No. 1 3-(Diethoxyphosphinyl)difluoromethylcyclopentene (106)
- No. 2 3-(Diethoxyphosphinyl)difluoromethylcyclohexene (107)
- No. 3 3-(Diethoxyphosphinyl)difluoromethylcycloheptene (108)
- No. 4 1-Methyl-(diethoxyphosphinyl)-2,2-difluoroethylbenzene (120)
- No. 5 1-(Diethoxyphosphinyl)difluoromethyl-2,3-epoxycyclohexene (127)
- No. 6 3-(Diethoxyphosphinyl)difluoromethylcyclohexen-6-ol (141)
- No. 7 3-Bromo-6-(diethoxyphosphinyl)difluoromethylcyclohexene (142)
- No. 8 3-[N9-(6-chloropurinyl)]-6-(diethoxyphosphinyl)difluoromethylcyclohexene (145)
- No. 9 3-(N9-Adenyl)-6-(diethoxyphosphinyl)difluoromethylcyclohexene (147)
- No. 10 3-(N9-Adenyl)-6-(dihydroxyphosphinyl)difluoromethylcyclohexene (139)
- No. 11 3-[N9-(2-amino-6-chloropurinyl)]-6-(diethoxyphosphinyl)difluoromethylcyclohexene (149)
- No. 12 3-(Ethoxyhydroxyphosphinyl)difluoromethyl-6-(N9-guanyl)cyclohexene (151)
- No. 13 3-(N9-Guanyl)-6-(dihydroxyoxyphosphinyl)difluoromethylcyclohexene (140)
- No. 14 1-Bromo-2-(diethoxyphosphinyl)difluoromethylcyclohexane (153)
- No. 15 (Dihydroxyphosphinyl)bromodifluoromethane (154)
- No. 16 1-Bromo-2-(dihydroxyphosphinyl)difluoromethylcyclohexane (156)
- No. 17 1-(Diethoxyphosphinyl)difluoromethyl-2-iodocyclohexane (159)
- No. 18 1-(Diethoxyphosphinyl)difluoromethyl-2-iodocyclopentane (160)
- No. 19 1-(Diethoxyphosphinyl)difluoromethyl-2-iodocycloheptane (161)
- No. 20 Methoxy-2,2,4,4,4-pentafluorobutane (174)
- No. 21 Oligmers based on methoxy-4,4,4-trifluorobutane (175)
- No. 22 2-(1,1,3,3,3-Pentafluoropropyl)oxolane (177)
- No. 23 2-Chloro-5-(1,1,2,3,3,3-hexafluoropropyl)oxolane (186)
- No. 24 2-Chloro-5-(1,1,3,3,3-pentafluoropropyl)oxolane (187)
- No. 25 2-Chloro-5-(2-chloro-1,1,2-trifluoroethyl)oxolane (188)
- No. 26 2-(1,1,2,3,3,3-hexafluoropropyl)-4,5-dihydrofuran (189)
- No. 27 2-(2-Chloro-1,1,2-trifluoroethyl)-5-uradyloxolane (192)
- No. 28 2-(2-Chloro-1,1,2-trifluoroethyl)-5-(5-fluorouradyl)oxolane (193)
- No. 29 2-(1,1,3,3,3-Pentafluoropropyl)-5-uradyloxolane (194)
- No. 30 2-(1,1,3,3,3-Pentafluoropropyl)-5-(5-fluorouradyl)oxolane (195)

- No. 31 2-(1,1,2,3,3,3-Hexafluoropropyl)-5-uradyloxolane (196)
- No. 32 2-(1,1,2,3,3,3-Hexafluoropropyl)-5-(5-fluorouradyl)oxolane (197)
- No. 33 Uradylmethoxy-2,2,3,4,4,4-hexafluorobutane (198)
- No. 34 5-Fluorouradylmethoxy-2,2,3,4,4,4-hexafluorobutane (199)
- No. 35 2-Amino-6-chloropurinylmethoxy-2,2,3,4,4,4-hexafluorobutane (205)
- No. 36 2-(6-Chloropurinyl)-5-(1,1,2,3,3,3-hexafluoropropyl)oxolane (206)
- No. 37 2-(2-Amino-6-chloropurinyl)-5-(1,1,2,3,3,3-hexafluoropropyl)-oxolane (207)
- No. 38 2-(6-Chloropurinyl)-5-(1,1,3,3,3-pentafluoropropyl)oxolane (208)
- No. 39 2-(2-Chloro-1,1,2-trifluoroethyl)-5-(6-chloropurinyl)oxolane (209)
- No. 40 Guanylmethoxy-1,1,2,3,3,3-hexafluorobutane (210)
- No. 41 2-(1,1,2,3,3,3-Hexafluoropropyl)-5-guanlyloxolane (211)
- No. 42 2-Adenyl-5-(1,1,2,3,3,3-hexafluoropropyl)oxolane (212)
- No. 43 2-Adenyl-5-(1,1,3,3,3-pentafluoropropyl)oxolane (213)
- No. 44 2-Adenyl-5-(2-chloro-1,1,2-trifluoroethyl)oxolane (214)
- No. 45 2-(1,1,3,3,3-Pentafluoropropyl)-5-(5-fluoro-5,6-dihydro-6-hydroxyuradyl)oxolane (202)

Spectrum No.1 (EI+)

NCP454L034* x1 Bgd=1 15-MAY-92 11:56:08:03:16 78E EI+
 BpM=0 I=4.0v Hm=431 TIC=48121000 Acnt: Sys:ACE HMR: 1024000
 WIGEL PARKINSON PT= 0° Cal:PFKBHAYS MASS: 255

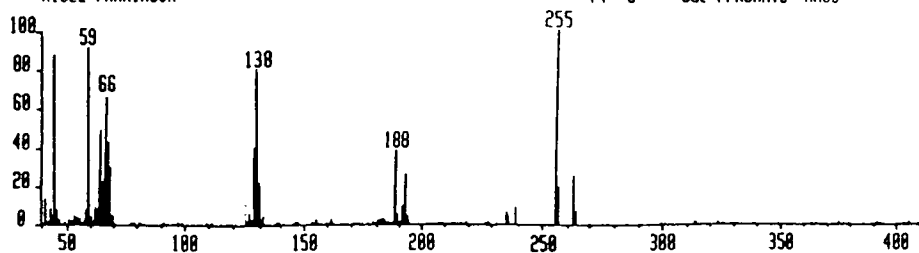

Mass % Base

42.02	17.89
44.03	6.55
45.02	87.78
46.04	6.45
53.03	3.54
54.05	3.44
55.04	3.36
58.03	8.67
59.03	91.04
60.02	3.50
62.03	8.99
63.03	8.84
64.02	48.40
65.03	22.35
66.02	68.61
67.02	46.64
68.03	33.43
69.02	5.03
135.00	5.11
136.99	45.76
138.00	82.57
139.02	22.76
162.02	2.11
182.02	2.02
183.03	2.04
184.03	2.04
188.03	43.00
189.02	2.43
191.03	8.76
192.02	24.19
193.02	3.00
245.03	6.54
246.02	5.99
249.00	10.01
255.01	100.00
256.02	26.21
262.02	23.98
263.03	7.55

Mass Spectrum No. 2 (CI+)

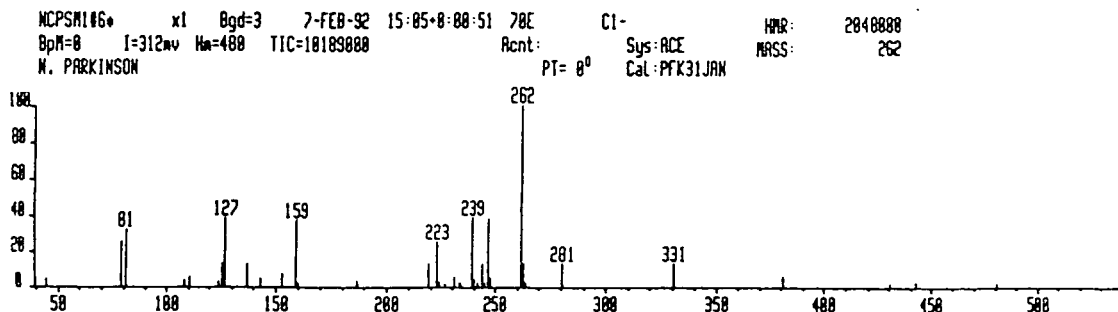
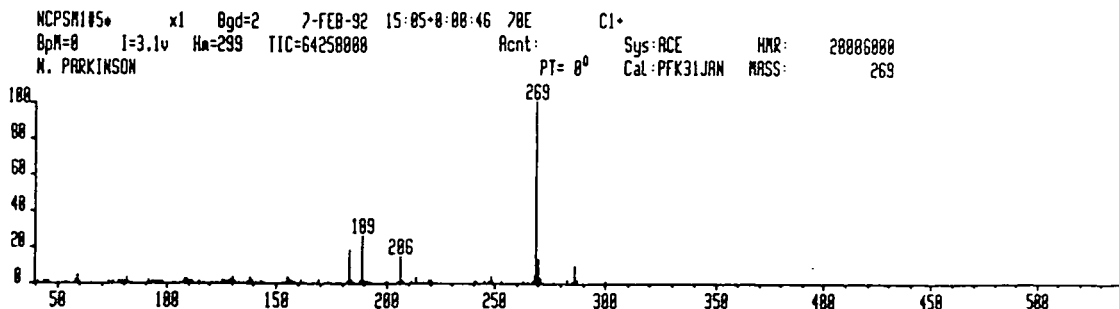
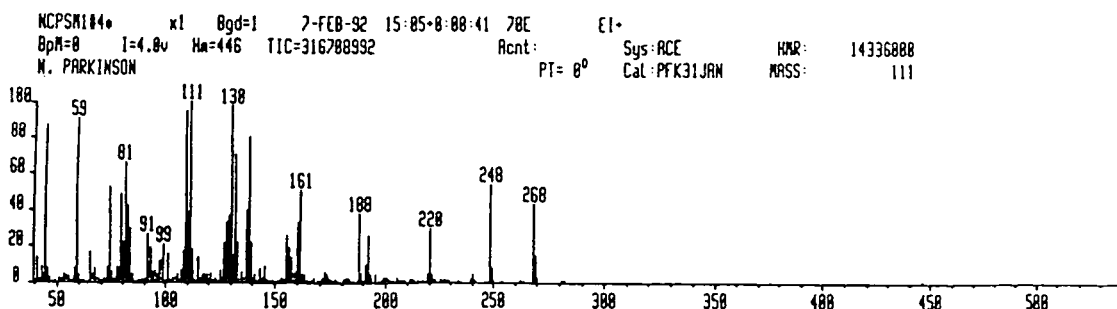

Mass	% Base
58.03	1.12
59.02	3.91
81.02	2.56
91.00	1.19
108.00	1.79
108.98	1.63
109.99	0.44
110.98	1.28
125.96	1.29
137.96	2.56
138.98	1.28
154.96	2.56
155.99	1.33
161.02	1.50
168.97	1.28
182.96	18.15
183.97	1.28
187.93	1.28
188.92	25.59
189.93	1.45
205.94	14.16
206.94	1.28
210.97	0.51
212.95	2.56
218.93	1.28
219.93	1.28
247.94	3.16
267.92	3.84 F
268.92	100.00 F
269.94	12.80 F
270.95	2.50
282.92	1.21
284.95	0.36
285.96	8.96
286.96	1.28
299.93	0.78

Spectrum No.3 (CI+)

MASS SPECTRUM Data File: G911073C
Sample: N. PARKINSON NCP167 AMMONIA
RT 0'03" CI (Pos.) GC 26.5c BP: m/z 283.0000
Scan# (11)

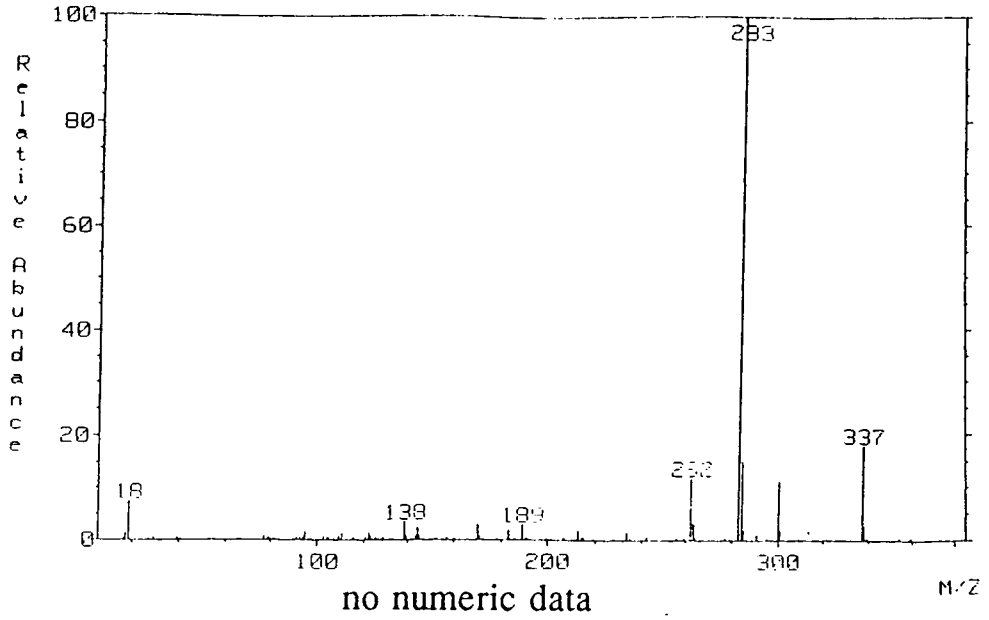

Mass Spectrum No. 4 (EI+)

MCP48MS11287 x1 Bgd=1267 3-MAY-98 18:00:0:18:05 70E EI+
 BpM=0 I=10v Ha=294 TIC=338651088 Rcnt: FINEORG Sys: PARKINSON HR 65534000
 FR3 0.1 MSEC GC= 209⁰ Cal: PFK16JAN MASS 105
 *x1.0

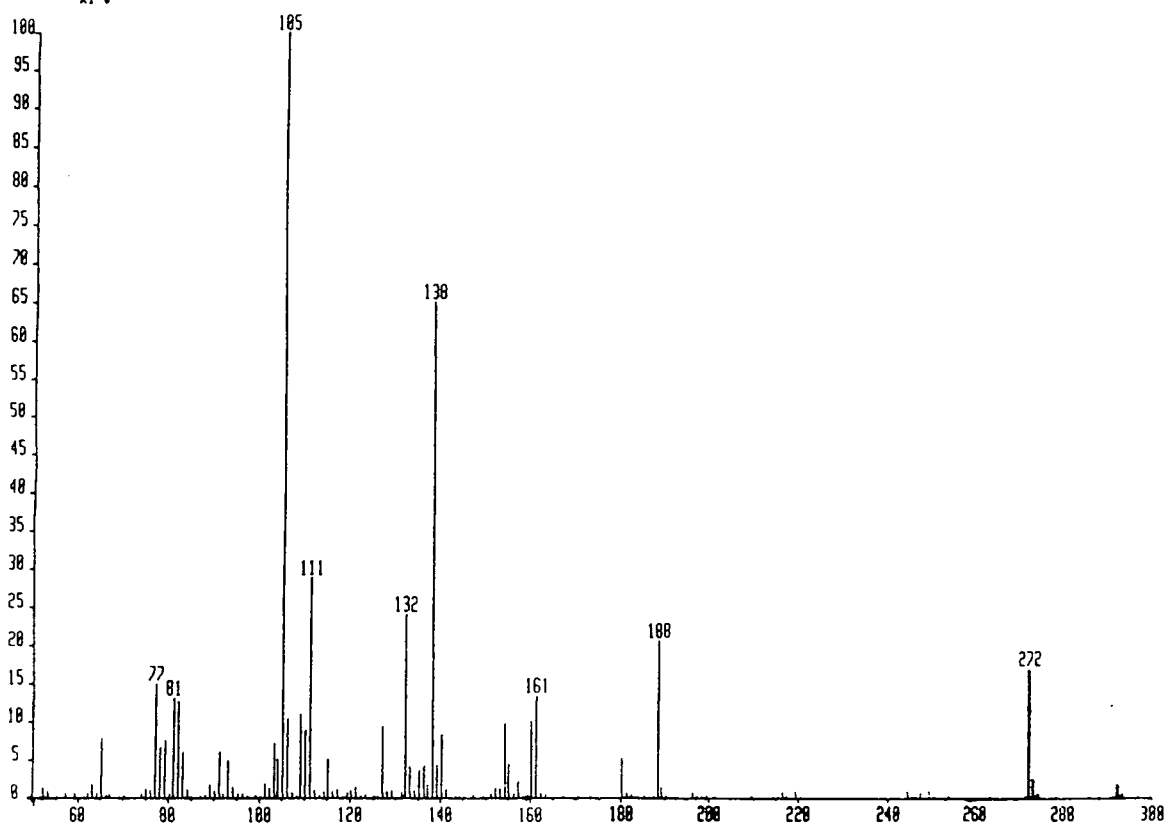

Mass	% Base
65.13	6.37 F
77.22	12.42
78.23	5.14
79.24	5.98
81.17	10.54
82.18	10.56
91.25	5.12
103.29	5.80
105.31	100.00 F
106.31	8.94
109.26	9.03
110.25	7.35 F
111.25	23.10 F
127.28	7.64
132.24	19.45
138.32	54.03 F
140.32	6.43
154.35	8.13
160.31	8.47
161.32	10.96
188.36	17.03
271.48	0.07
272.46	13.71
273.47	2.00
274.47	0.22
277.46	0.09
291.47	0.12
292.46	1.49
293.47	0.33
294.49	0.04

Spectrum No.5 (EI+)

NCP454L#34* x1 Bgd=1 15-MAY-92 11:56:08:16 70E EI+
 BpM=0 I=4.8v Hm=431 TIC=48121000 Acnt: Sys: ACE HMR: 31234000
 NIGEL PARKINSON PT= 0° Cal: PFKOMAYS MASS: 285

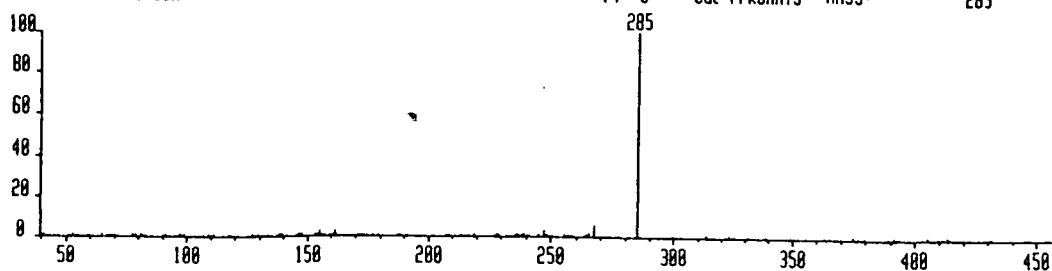

NCP454L#35* x1 Bgd=14 15-MAY-92 11:56:08:22 70E CI+
 BpM=0 I=2.5v Hm=382 TIC=22659000 Acnt: Sys: ACE HMR: 16361000
 NIGEL PARKINSON PT= 0° Cal: PFKOMAYS MASS: 285

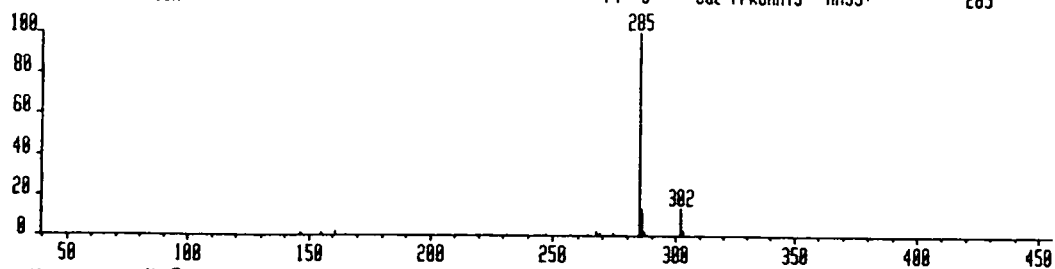

Mass	% Base
41.25	0.82
53.17	0.77
65.06	0.77
77.04	0.82
79.06	0.82
81.00	0.82
91.05	0.74
97.09	0.82
99.06	0.77
109.05	0.82
111.06	0.82
127.07	0.82
129.08	0.83
138.08	0.39
139.07	0.33
146.08	0.82
147.10	0.82
153.11	0.36
155.11	1.81
161.15	1.64
219.08	0.33
228.09	0.61
229.04	0.36
236.08	0.33
239.07	0.77
245.09	0.77
247.04	2.64
248.09	0.54
255.09	0.35
257.08	0.82
264.09	0.85
265.08	1.17
267.21	4.92
285.04	100.00

Spectrum No.6 (EI+)

NCP45417* x1 Bgd=1 15-MAY-92 11:38:00:58 70E EI+
 BpM=0 I=3.0v Hw=779 TIC=27276000 Acnt: Sys ACE HMR: 19778000
 NIGEL PARKINSON PT= 0° Cal PFK0MAYS MASS 139

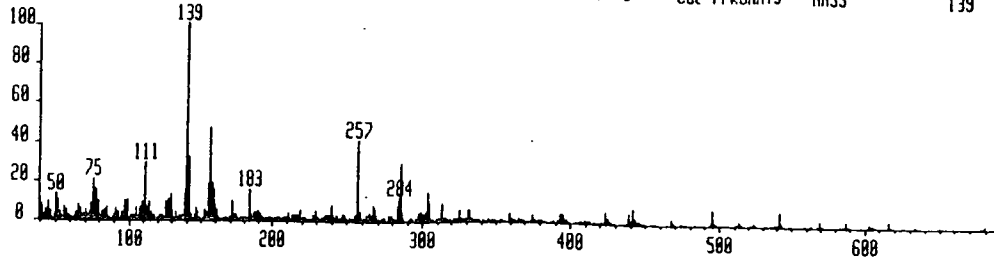

NCP45418* x1 Bgd=2 15-MAY-92 11:38:01:03 70E C1-
 BpM=0 I=10v Hw=614 TIC=110443000 Acnt: Sys ACE HMR: 6656000
 NIGEL PARKINSON PT= 0° Cal PFK0MAYS MASS: 303

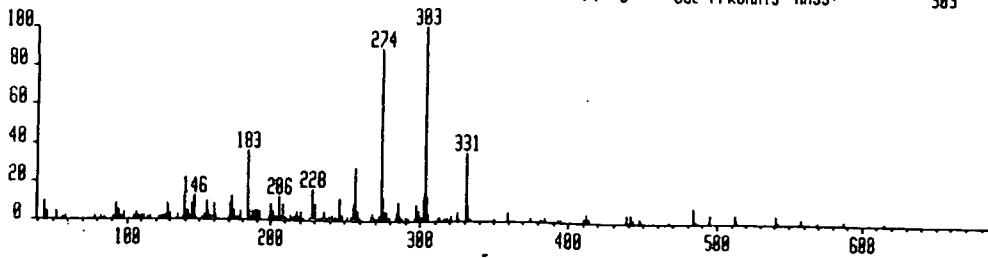

Mass	% Base	Mass	% Base	Mass	% Base	Mass	% Base
40.24	1.29	93.03	4.00	151.03	1.35	227.03	2.59
41.24	7.91	94.04	1.31	152.07	5.18	228.04	1.29
42.23	2.59	95.05	3.81	153.06	3.88	229.02	4.32
43.21	5.33	96.05	2.59	154.05	1.29	230.04	1.29
44.19	2.71	97.06	9.40	155.03	18.14	231.04	1.29
45.19	9.06	98.07	7.77	155.99	46.60	233.05	1.29
46.20	1.29	99.01	10.35	156.99	18.73	235.03	1.98
47.13	2.59	100.04	1.29	157.98	15.70	236.04	2.59
47.21	4.69	101.00	2.59	159.00	7.77	237.03	2.59
49.15	2.59	102.03	1.18	160.00	5.18	238.03	2.88
50.15	12.94	103.03	2.59	161.07	5.19	239.03	7.99
51.15	9.43	104.03	1.49	162.07	1.29	240.03	2.59
52.15	1.57	105.03	6.56	167.05	1.29	241.03	1.29
53.14	3.89	106.03	1.97	169.05	1.29	243.02	2.59
54.15	1.65	107.04	6.47	170.06	1.31	244.05	1.29
55.13	6.47	108.04	2.59	171.08	9.30	245.04	1.29
57.13	5.18	109.02	9.06	172.06	2.59	247.05	2.98
58.13	1.29	110.01	5.19	173.02	2.61	248.05	2.59
59.12	2.84	111.00	28.55	174.06	2.59	249.01	1.29
60.08	1.29	112.00	6.48	175.03	1.53	251.03	1.47
61.07	1.46	112.99	9.06	177.04	1.29	255.02	2.59
62.08	1.29	114.01	2.59	179.02	1.33	256.04	2.59
63.08	3.91	115.03	3.88	181.04	1.29	257.04	40.86
64.07	1.30	116.04	1.29	182.03	1.29	258.04	4.19
65.06	7.77	117.05	2.59	183.06	15.53	259.04	1.29
66.07	1.58	118.05	1.29	184.05	2.59	261.05	1.29
67.08	5.60	119.05	1.31	185.04	1.29	263.04	1.29
68.06	2.59	121.03	2.77	186.03	1.29	264.05	2.53
69.06	2.75	122.04	1.29	187.02	3.80	265.05	3.99
70.05	5.18	123.04	2.59	188.02	4.08	266.02	2.59
71.04	2.59	124.05	1.50	189.04	4.20	267.05	1.29
72.03	1.29	125.06	9.06	190.01	1.57	268.06	7.77
73.02	3.88	126.05	2.59	191.01	3.47	269.04	6.61
74.02	8.23	127.02	10.35	192.03	1.29	273.05	2.46
75.02	20.71	128.03	5.18	193.03	1.29	274.05	1.29
76.02	7.77	129.04	12.94	199.05	1.58	275.05	1.29
77.02	15.66	130.05	4.22	201.04	1.29	277.05	2.34
78.03	3.91	131.05	1.50	203.04	1.29	279.04	2.59
79.04	9.80	131.98	3.88	205.04	1.29	281.03	1.29
80.04	2.59	133.02	1.30	207.02	1.49	283.03	7.77
81.01	4.22	135.09	2.81	208.02	1.29	284.04	11.65
81.98	3.88	136.08	1.17	209.01	1.48	285.05	29.71
82.99	5.18	137.04	2.59	210.01	1.29	286.05	3.88
84.00	1.43	138.04	12.94	211.02	3.88	287.04	1.29
85.02	6.47	138.99	100.00	213.04	2.59	291.03	0.49
86.02	1.29	140.00	8.12	215.03	2.59	292.07	1.29
87.00	1.29	140.99	32.36	216.04	1.22	293.03	1.29
89.02	1.29	142.01	3.11	217.06	2.35	295.03	1.29
90.02	2.59	143.05	2.59	218.04	1.47	296.04	0.42
91.03	5.53	145.04	2.59	219.04	5.18	297.05	3.88
92.04	2.59	146.04	5.87	220.05	1.52	298.05	0.54
		147.05	3.93	221.05	1.29		

Spectrum No.7(CI+)

MASS SPECTRUM Data File: G911330G
Sample: N.PARKINSON NCP180 AMMONIA
RT 0'17" CI (Pos.) GC 0.0c BP: m/z 364.0000
Scan# (4)

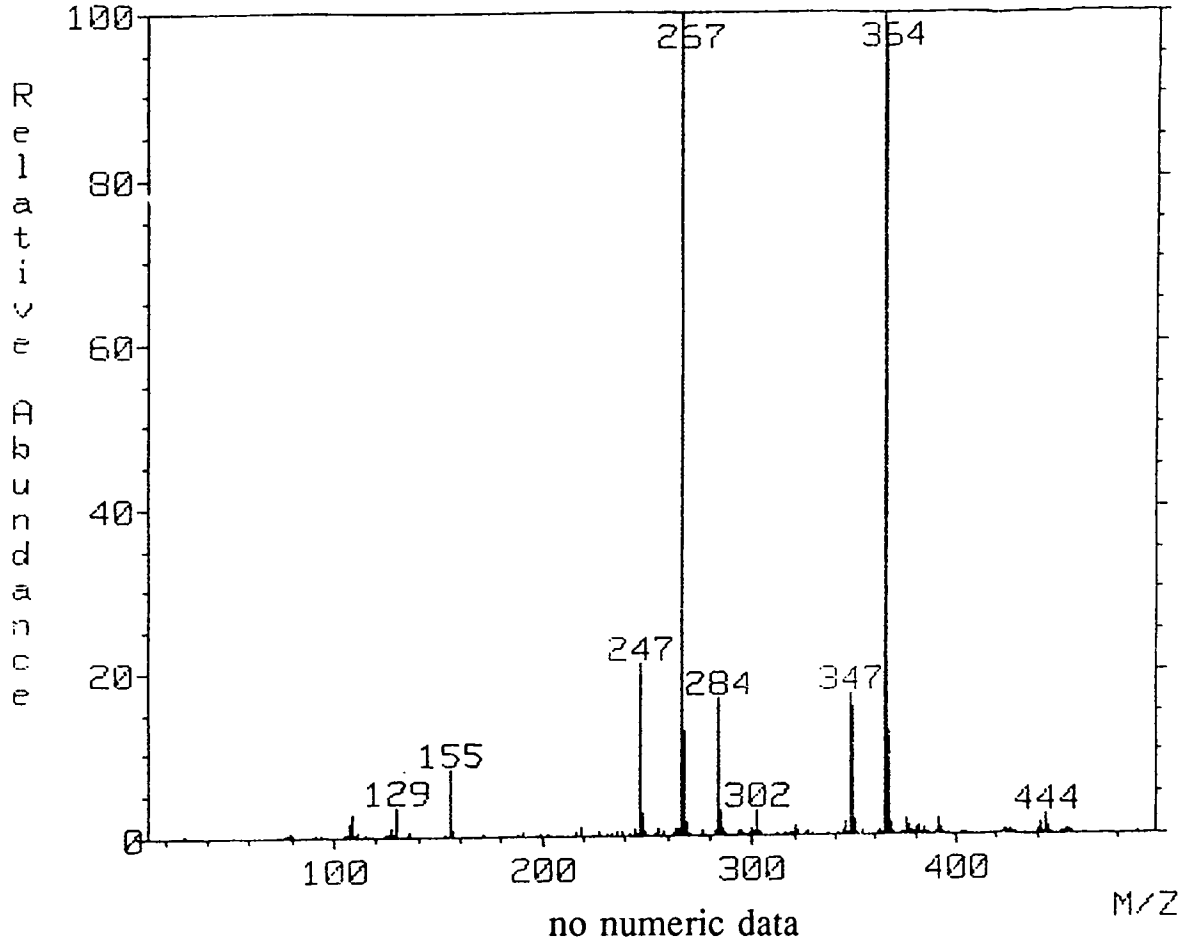

Spectrum No.8 (CI+)

NCP190H#22* x1 Bgd=1 26-SEP-91 16:25-0:02:18 70E E1+
 BpM=0 I=2.9v Hm=686 TIC=141301000 Acnt: Sys:ACE HR 6343000
 N. PARKINSON PI= 0° Cal: PFK26SEP MASS 421

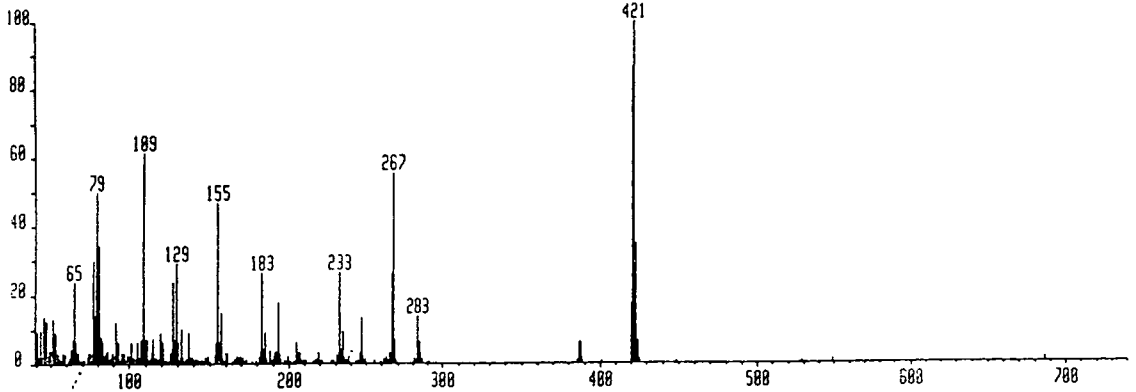

NCP190H#26* x1 Bgd=20 26-SEP-91 16:25-0:02:39 70E C1+
 BpM=0 I=10v Hm=582 TIC=422552000 Acnt: Sys:ACE HR 57703000
 N. PARKINSON PI= 0° Cal: PFK26SEP MASS 183

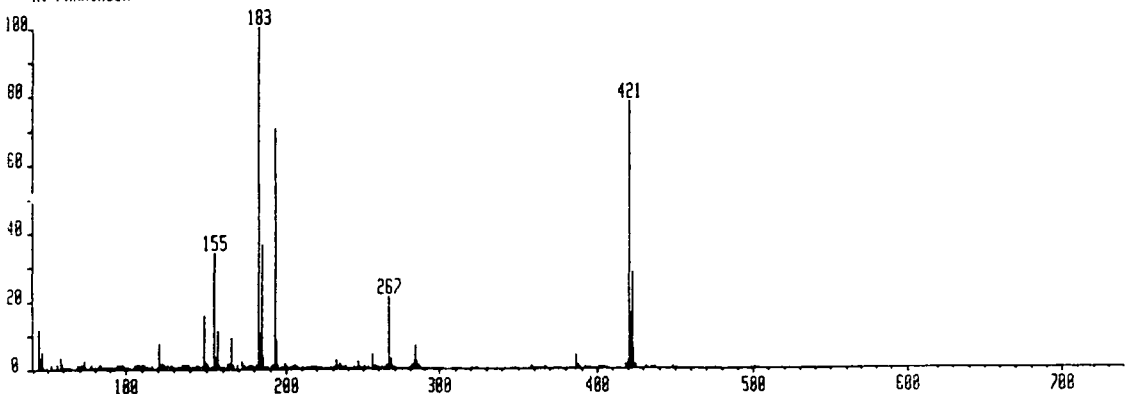

Mass	% Base
43.98	9.85
44.98	2.73
46.01	4.55
58.03	2.58
59.03	1.19
120.98	6.25
122.00	1.16
123.00	1.17
148.99	13.60
149.98	1.56
154.91	29.80 F
155.94	2.73 F
156.91	9.56 F
163.00	1.27
164.00	1.22
164.98	7.97
182.95	88.17 F
183.93	9.02 F
184.92	32.06 F
185.92	3.13 F
191.93	1.00 F
192.98	61.97 F
193.99	7.20 F
198.98	1.13
232.92	2.08
233.94	0.40
234.93	1.18
246.94	1.95
255.94	3.52
266.90	18.34 F
267.92	2.34 F
282.88	1.70
283.93	6.00
284.91	1.82
386.79	3.20
419.70	1.74
420.77	68.98
421.77	14.07
422.77	24.66
423.76	4.69
424.93	0.94
434.82	0.39

N=...

Spectrum No.9 (FAB+)

NCP32015* x1 Bgd=1 7-NOV-91 14:16:00:59 70E FB+
 BpM=0 I=9.1v Hm=895 TIC=718318976 Acnt: Sys:FAB HMR: 59892800
 N. PARKINSON PT= 0° CaL:PFK14OCT MASS: 164

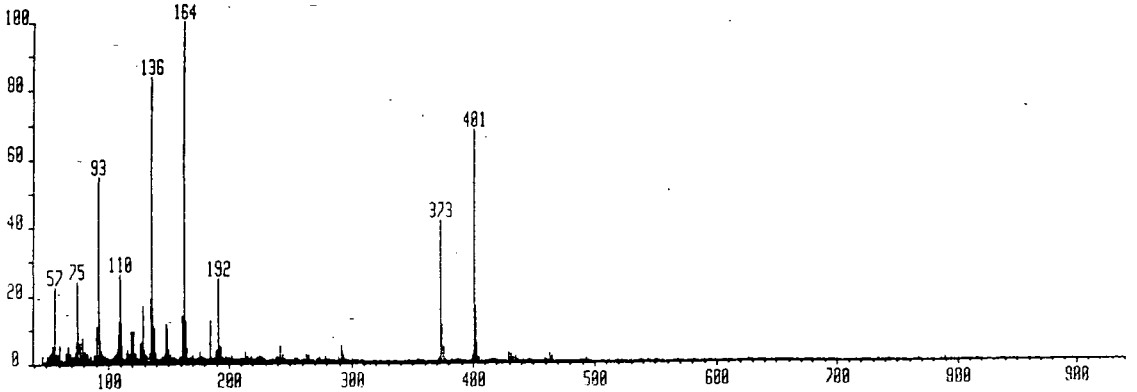

NCP32018* x1 Bgd=6 7-NOV-91 14:16:01:20 70E FB-
 BpM=0 I=1.6v Hm=884 TIC=122610000 Acnt: Sys:FAB HMR: 18398000
 N. PARKINSON PT= 0° CaL:PFK14OCT MASS: 399

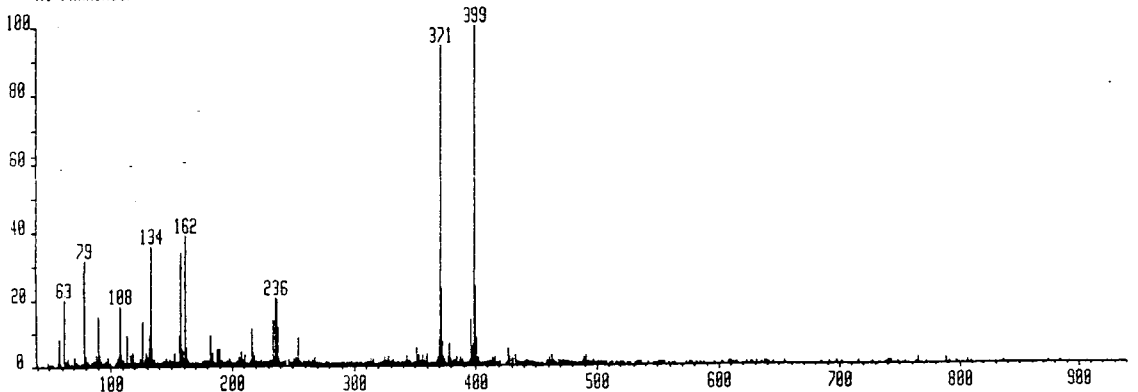

Mass	% Base	Mass	% Base	Mass	% Base
46.82	1.99	108.78	11.90	192.69	4.66
50.77	2.12	109.81	25.88	193.70	4.28
52.79	2.76	110.79	5.13	194.66	1.71
53.79	2.99	114.76	2.68	201.68	2.16
54.79	5.23	115.81	3.77	213.65	3.16
55.80	4.70	116.78	2.58	214.67	1.38
56.80	22.14	117.77	1.79	215.65	2.20
57.82	2.56	118.75	9.17	225.58	2.00
58.81	2.65	119.75	7.13	238.59	1.88
59.80	1.86	120.76	9.20	239.62	1.87
60.79	5.16	121.76	2.84	240.62	1.12
64.78	3.09	122.77	2.81	241.64	4.70
65.81	2.13	126.74	5.71	242.64	1.42
66.82	4.71	127.76	1.38	243.65	2.50
67.82	2.01	128.74	16.93	244.62	0.86
68.83	2.61	129.80	3.65	263.58	2.57
69.84	1.77	130.76	1.73	264.58	1.98
70.84	1.98	131.71	2.28	265.58	2.03
72.83	3.12	132.70	1.81	290.57	0.57
73.81	4.30	133.76	2.76	291.58	4.75
73.88	6.02	134.74	18.75	292.59	3.00
74.83	24.07	135.74	83.42	293.58	2.02
75.83	1.29	136.74	10.72	372.45	1.87 F
76.82	5.94	137.78	9.96	373.46	41.53 F
77.83	2.39	138.76	2.61	374.46	11.01 F
78.84	7.07	146.72	2.57	375.47	4.44 F
79.83	2.18	147.72	11.16	399.45	1.71 F
80.83	3.42	148.70	10.05	400.43	3.06 F
81.81	2.10	149.72	3.61	401.46	67.95 F
82.82	2.70	150.72	1.90	402.46	16.41 F
88.81	2.39	151.72	2.40	403.48	5.56 F
89.81	1.95	159.69	1.79	404.47	1.28 F
90.82	10.46	160.71	1.58	405.47	1.27 F
91.81	2.27	161.71	13.75		
92.82	54.35	162.71	9.64		
93.81	6.61	163.72	100.00		
94.81	3.30	164.72	12.30		
95.81	2.56	165.72	3.97		
96.81	1.96	175.69	3.12		
103.79	1.72	176.69	1.73		
104.79	2.23	177.70	1.87		
105.79	2.70	189.68	3.42		
106.78	4.00	190.65	3.86		
107.79	8.16	191.71	24.71		

Spectrum No.10 (FAB+)

273

MCPROF12* x1 Bgd=1 28-JUL-92 16:02:00 00:44 78E FB+ 2133880 !
 BpM=0 I=325mv Ha=1813 TIC=30041000 Acnt: Sys:FABHI HMR: 45
 NIGEL P. PT= 0° Cal:PFKBJULS MASS *x10⁻⁶ x10⁻⁶

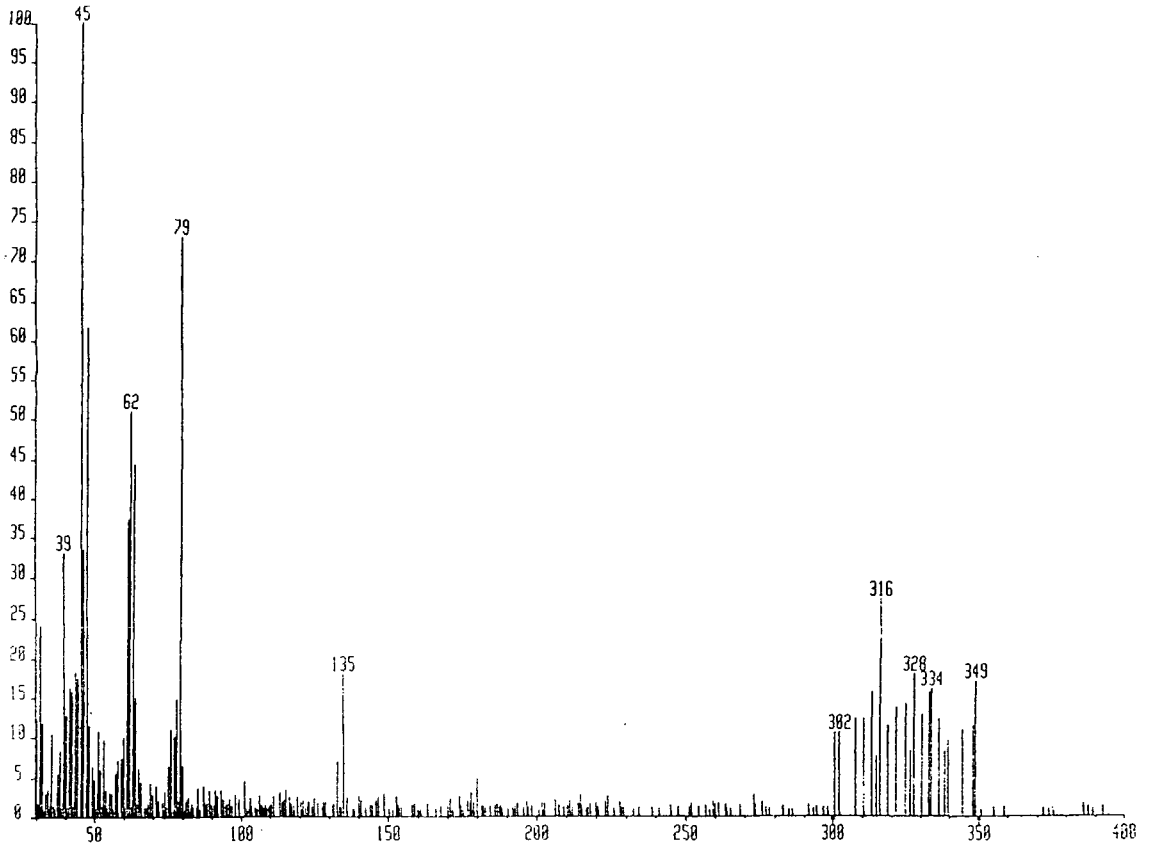

Mass	% Base	Mass	% Base	Mass	% Base	Mass	% Base
40.08	12.71	63.03	44.16	93.02	3.19	201.97	1.55
40.14	4.97	64.03	14.96	93.89	0.94	202.96	1.55
40.26	1.08	64.28	1.45	93.97	2.02	206.47	2.02
40.99	1.08	65.03	6.05	94.81	1.36	211.08	1.92
41.10	1.97	66.05	4.17	95.20	1.50	214.07	1.59
41.15	16.17	67.24	1.08	96.00	2.02	214.97	2.58
42.13	15.75	67.84	1.08	96.51	1.36	219.97	1.73
42.52	1.17	68.45	1.45	97.88	1.17	223.04	2.16
43.13	18.19	68.99	4.03	97.99	2.67	224.01	2.53
43.30	1.17	69.06	3.05	98.97	2.02	228.11	1.69
44.13	17.39	70.03	2.58	100.98	4.36	251.99	1.55
45.08	100.00	71.00	3.84	103.02	2.25	261.28	1.59
45.14	5.91	71.32	1.17	106.04	2.44	273.07	2.58
45.69	1.22	71.95	1.83	111.03	2.48	276.05	1.73
46.08	33.43	72.93	1.73	112.99	2.95	313.24	1.55
46.16	7.69	74.01	3.05	114.01	1.64	314.83	0.75
47.09	61.65	74.22	1.17	114.09	1.83	316.06	2.72
47.36	1.08	75.00	6.33	115.01	3.14	318.96	1.13
47.99	1.27	75.57	1.17	116.03	2.39	321.84	1.36
48.07	11.39	76.01	10.97	116.16	1.17	324.79	1.27
49.08	6.33	77.01	10.03	116.75	1.41	324.99	1.41
51.11	10.64	78.00	14.77	116.97	1.45	326.41	0.80
51.81	1.45	78.42	1.08	118.85	1.78	327.73	1.78
52.11	5.91	78.77	1.88	119.03	2.34	330.70	1.27
52.74	1.22	79.00	72.86	120.05	1.69	333.03	1.55
53.11	9.70	79.99	6.24	120.97	1.92	333.70	1.59
53.70	1.17	80.98	2.06	122.99	1.73	336.74	1.22
54.11	3.28	82.01	2.34	124.36	1.17	338.42	0.80
54.19	1.08	82.97	1.45	124.93	2.16	339.80	0.94
55.09	2.95	83.50	1.03	131.96	1.50	344.55	1.08
55.17	1.64	83.54	0.80	132.88	6.89	348.06	1.13
55.99	1.92	84.62	1.03	133.00	3.14	349.10	1.69
56.01	2.30	85.00	3.52	135.02	18.00	350.85	0.80
56.06	1.73	86.00	1.03	136.01	2.20	355.48	0.98
56.12	2.77	87.00	3.84	139.97	2.53	358.99	1.17
57.07	5.44	87.18	0.98	141.02	1.88	372.18	0.94
57.48	1.08	87.35	1.59	147.00	2.39	373.94	0.94
58.00	1.03	87.97	1.22	149.01	2.77	375.46	0.94
58.05	7.03	88.14	1.64	153.03	2.44	385.88	1.41
58.11	3.19	88.98	3.19	163.14	1.59	387.75	1.13
59.05	7.31	89.93	1.36	173.92	2.44	389.33	0.89
59.11	2.48	90.00	1.41	177.01	1.97	392.86	1.17
60.05	9.94	90.56	1.31	177.85	1.64		
61.05	37.27	91.02	3.28	178.02	2.91		
62.05	51.01	91.38	1.03	178.93	1.59		
62.57	1.17	91.84	1.08	180.05	4.64		
		92.00	2.53	193.78	1.59		

Spectrum No.11(FAB+) 274

NCP422#20* x1 Bgd=6 5-MAY-92 14:17:0:02:46 70E FB-
 BpM=0 I=70mv Hm=800 TIC=8416000 Acnt: Sys:FAB HMR: 512000
 NIGEL PARKINSON PT= 0° Cal:PFKSMAY MASS: 183

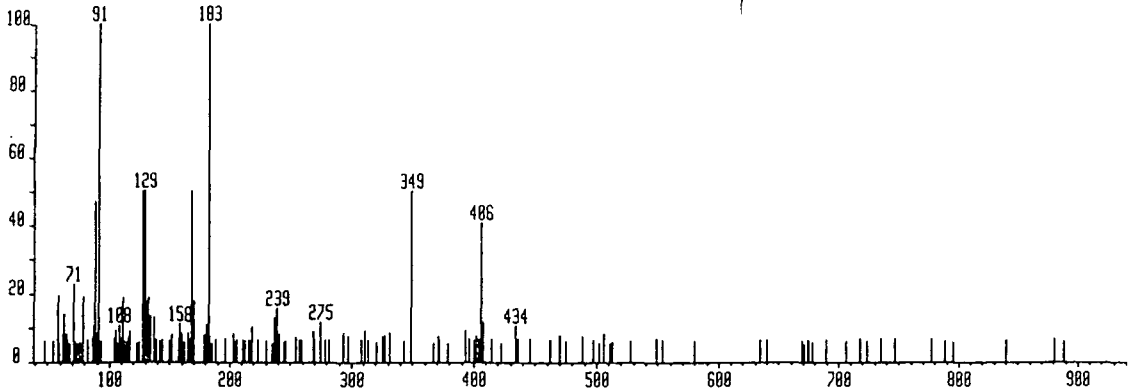

NCP422#21* x1 Bgd=15 5-MAY-92 14:17:0:02:54 70E FB+
 BpM=0 I=460mv Hm=891 TIC=74239000 Acnt: Sys:FAB HMR: 3872000
 NIGEL PARKINSON PT= 0° Cal:PFKSMAY MASS: 93

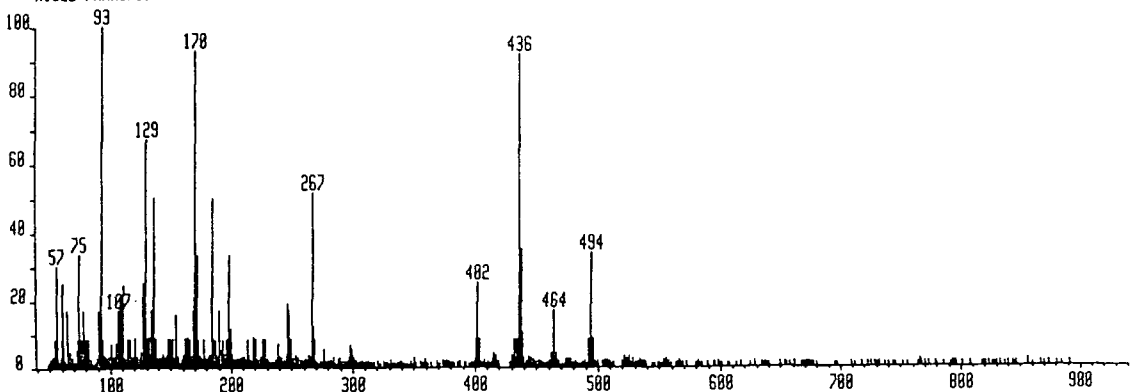

Mass	% Base	Mass	% Base	Mass	% Base	Mass	% Base
50.90	2.44	107.00	16.67	155.01	15.53	246.98	18.68
52.92	3.06	108.01	3.55	156.01	2.21	247.96	16.67
53.92	2.28	109.00	19.99	156.98	3.06	249.00	3.71
54.92	8.33	110.01	8.33	159.01	2.25	250.00	8.33
55.92	8.33	111.01	24.45	159.97	3.58	266.97	51.24
56.93	30.24	112.02	2.70	160.98	3.74	267.98	11.98
57.95	1.69	112.99	2.54	162.01	8.72	268.98	8.33
58.95	2.83	115.00	8.11	163.01	8.33	277.01	5.05
59.94	8.33	115.96	2.08	164.02	9.02	297.00	3.03
60.94	25.00	117.00	8.33	165.00	8.33	297.94	6.61
61.95	2.12	118.01	1.79	166.00	8.33	298.96	5.24
62.94	1.33	119.00	3.06	167.00	3.16	299.93	3.55
64.92	16.67	120.00	2.12	168.00	3.32	350.93	2.67
65.97	1.86	120.99	8.40	168.95	16.67	358.98	2.28
66.99	4.36	122.01	2.28	169.95	92.87	400.94	8.33
67.98	2.77	123.01	2.93	170.95	16.67	401.94	25.00
68.97	2.86	124.01	2.38	171.95	33.33	402.95	8.33
73.00	5.11	125.00	4.62	172.97	8.11	403.94	8.33
73.99	8.33	126.00	2.08	174.02	3.39	414.94	2.28
75.00	33.46	126.99	25.00	174.98	3.32	415.93	4.13
76.01	2.28	128.01	8.07	176.01	2.83	416.96	2.51
76.10	0.81	129.00	66.67	178.01	8.33	417.97	3.32
77.00	8.33	130.00	8.40	178.99	3.03	430.99	2.51
78.01	2.31	130.98	8.37	181.97	3.06	431.98	8.33
79.02	16.67	131.94	8.95	182.98	3.65	432.97	2.64
80.01	4.46	133.00	3.45	183.94	2.80	433.95	8.33
80.99	8.11	133.99	16.67	185.01	50.00	434.90	8.33
81.97	8.33	135.00	16.67	186.00	8.33	435.88	91.67
82.98	8.33	136.00	50.00	187.98	7.85	436.88	33.33
85.00	2.34	137.00	8.63	188.97	3.42	437.88	35.09
89.99	2.64	138.01	8.33	190.95	16.67	438.98	10.16
91.02	16.67	138.98	2.80	191.98	5.31	439.94	2.70
92.01	1.89	140.99	2.90	192.96	7.85	441.94	1.66
93.01	100.00	142.02	1.69	194.00	3.81	461.98	3.94
94.01	8.33	142.98	2.64	195.98	8.33	462.98	2.38
95.01	3.48	144.00	3.61	196.97	8.33	463.97	16.67
96.02	3.19	144.99	2.73	197.97	33.33	464.98	3.87
97.01	2.73	145.99	2.90	198.97	8.40	465.98	4.20
98.02	1.73	146.98	3.32	199.97	11.39	466.96	2.15
99.00	3.06	147.99	8.33	200.98	3.61	491.98	8.33
100.29	0.91	149.01	8.33	205.99	2.64	492.93	6.58
100.96	6.87	150.01	8.33	207.99	2.73	493.97	34.02
102.00	1.30	151.01	3.71	210.00	2.99	494.96	8.40
103.01	2.96	152.01	8.33	210.98	2.99	495.95	8.33
104.00	1.82	152.98	2.77	214.01	8.33	496.97	1.66
104.99	7.32	153.99	2.47	215.00	3.29		
				218.97	9.05		
				238.98	6.84		

Spectrum No.12 (FAB+)

NCPGUIT110 x1 Bgd=6 7-JUL-92 16:20:0:01:44 70E FB-
 BpM=0 I=148uv Hw=1212 TIC=10856000 Acnt: Sys:FABHI HMR: 971000
 NIGEL PT= 0° Cal:PFK6JULS MASS: 91

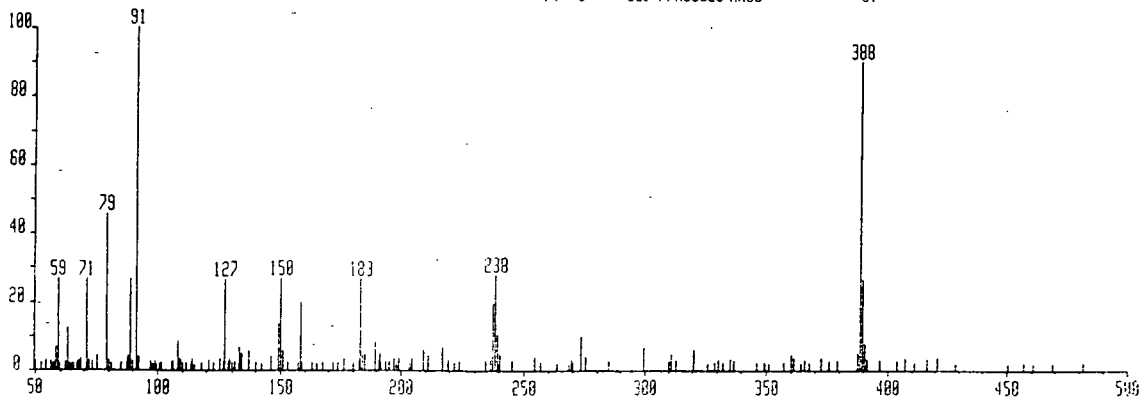

NCPGUIT111 x1 Bgd=1 7-JUL-92 16:20:0:01:52 70E FB+
 BpM=0 I=1.5v Hw=1191 TIC=106815000 Acnt: Sys:FABHI HMR: 9720000
 NIGEL PT= 0° Cal:PFK6JULS MASS: 152

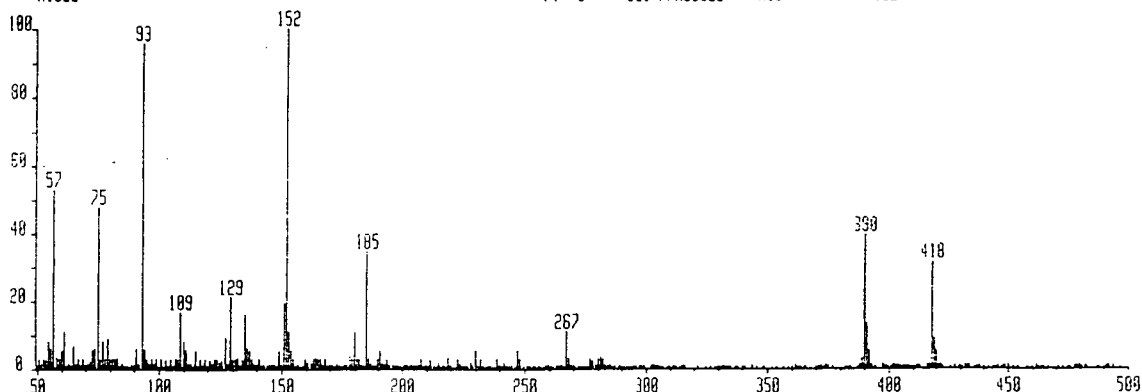

Mass	% Base	Mass	% Base	Mass	% Base	Mass	% Base
50.01	0.86	106.96	3.25	156.95	1.13	276.92	2.63
51.01	2.65	107.96	2.63	159.90	2.63	277.88	2.07
52.01	1.36	108.96	16.42	160.91	1.75	278.89	1.17
53.02	2.79	109.23	0.37	161.94	1.42	279.88	2.63
54.02	2.56	109.96	7.89	162.94	2.63	280.88	3.38
55.01	7.96	110.97	5.41	163.93	3.21	281.89	2.63
56.01	5.81	111.97	1.26	164.94	2.68	361.74	1.15
57.02	52.63	112.96	1.45	165.94	2.69	373.82	1.00
58.02	3.33	113.95	0.56	166.94	0.96	388.79	2.63
59.02	2.63	114.94	5.26	167.93	2.63	389.76	39.51
60.01	5.15	115.92	0.78	170.90	1.10	390.77	12.85
61.01	10.53	116.96	2.63	171.91	0.77	391.12	0.35
62.01	0.66	117.41	0.32	172.88	1.37	391.77	5.26
63.01	1.46	117.98	1.03	176.92	1.21	392.79	1.01
66.02	1.36	118.97	2.63	177.94	3.28	397.75	1.00
67.02	2.63	120.96	2.34	178.92	2.63	416.82	1.27
68.02	0.87	121.97	1.32	179.93	10.54	417.78	31.58 F
69.02	2.63	122.96	2.63	180.93	2.70	418.79	8.57 F
70.02	1.11	123.97	2.63	181.93	2.63	419.80	5.26
71.02	1.43	124.96	1.57	184.95	34.48	420.82	1.06
72.00	2.10	125.97	2.49	185.95	2.63	421.83	0.89
73.00	5.47	126.95	8.74	186.93	1.27		
74.00	5.77	127.96	1.26	189.90	2.63		
75.01	47.53	128.95	21.05	190.88	5.29		
76.01	2.66	129.96	2.86	191.89	1.28		
77.00	7.89	130.93	2.73	192.89	1.21		
78.01	2.63	131.89	3.20	193.89	2.49		
79.02	8.52	133.94	2.63	194.90	1.12		
80.01	2.63	134.51	0.41	200.90	1.08		
80.98	2.63	134.92	15.79	201.92	1.03		
81.74	0.39	135.95	5.81	206.92	1.03		
81.96	2.68	136.94	5.26	207.91	2.63		
82.98	3.00	137.95	2.63	211.98	2.33		
84.99	1.33	138.94	1.37	214.89	1.84		
89.97	1.13	139.96	0.90	218.88	3.16		
90.99	5.73	140.95	2.63	219.91	1.12		
91.98	1.46	141.96	0.64	222.87	2.63		
92.98	95.38	142.94	1.01	223.90	1.32		
93.98	5.46	145.94	1.05	229.91	5.26		
94.97	2.63	146.94	1.14	246.89	5.26		
95.98	1.31	148.93	5.26	247.90	2.63		
96.97	2.63	149.96	1.11	258.79	1.01		
97.98	1.31	150.92	19.15	259.88	1.11		
98.95	2.63	151.93	100.00	266.87	10.55		
100.91	2.63	152.92	10.53	267.89	2.63		
104.96	2.63	153.94	5.26				
		154.95	2.63				

Spectrum No.13(FAB+)

NCPGUF#6* x1 Bgd=5 28-JUL-92 15:37:01:21 70E FB*
 BpM=0 I=8.5v Hm=1016 TIC=345520992 AcntL: Sys:FABHI HAR: 55720000
 NIGEL P. PT= 0⁰ Cal:PFK0JULS MASS: 78
 x20*0*

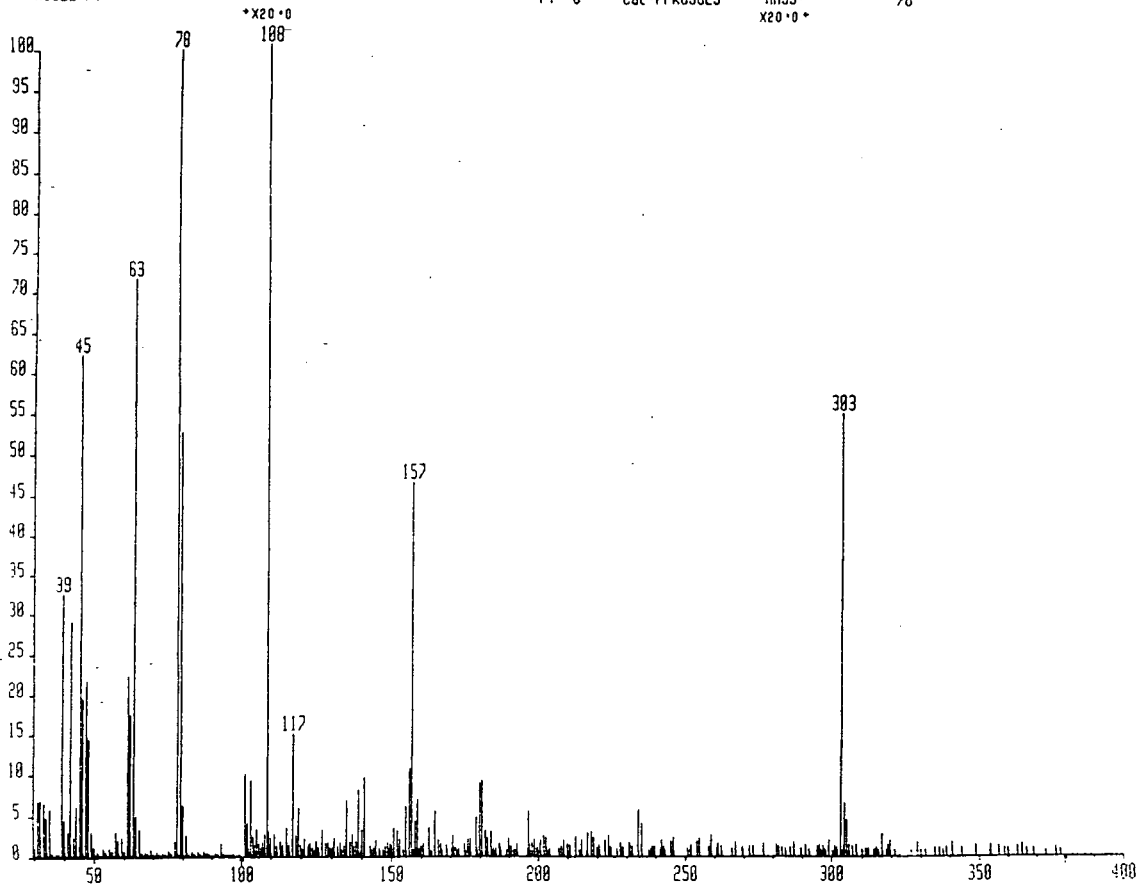

Mass	% Base	Mass	% Base
40.08	4.44	93.01	1.47
41.07	2.92 F	100.96	0.49
41.14	2.32 F	102.93	0.46
42.14	29.11	108.45	34.74
43.13	2.32	116.95	0.75
44.07	5.98 F	134.95	0.34
44.14	0.56 F	139.00	0.40
45.08	62.16 F	140.97	0.48
45.13	1.84 F	155.99	0.53
46.08	19.47	156.99	2.33
47.09	21.57	159.00	0.34
48.06	14.37	180.05	0.44
49.07	2.88	180.93	0.46
50.06	1.03	303.05	2.75
51.08	0.45	304.09	0.32
53.11	0.92		
54.10	0.37		
55.10	0.92		
56.03	0.61		
56.11	0.39		
57.03	2.91 F		
57.10	0.92 F		
58.04	1.84		
59.04	2.22		
60.04	0.60		
61.05	22.21		
62.04	17.32		
63.02	71.65		
64.02	4.88		
65.00	3.14 F		
65.06	0.70 F		
67.05	0.41		
68.05	0.34		
69.00	0.68		
71.00	0.46		
73.01	0.31		
75.00	0.65		
77.00	1.75		
77.98	100.00		
78.99	52.66		
79.98	6.13		
80.99	2.47		
82.98	0.46		
84.96	0.40		
86.95	0.45		

Spectrum No.14 (EI+)

NCP159#968* x1 Bgd=951 22-MAR-91 15:47+0:18:45 70E [I+
 BpM=0 I=7.6v Ha=272 TIC=696750000 Acnt: Sys: MULLI
 N. PARKINSON PT= 0° Cal: PFK22

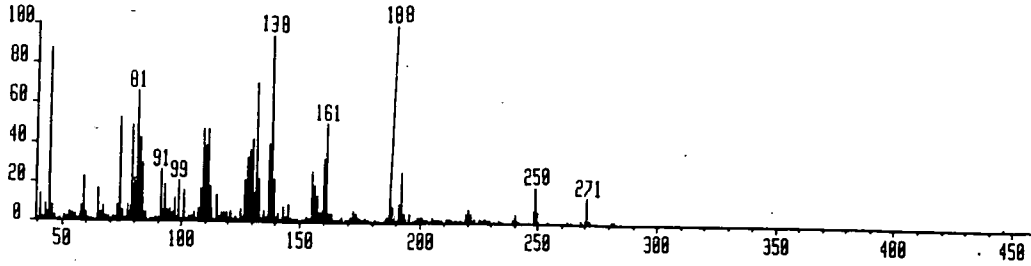

Mass	% Base	Mass	% Base
40.88	57.52	108.87	36.98
41.89	6.00	109.88	14.56
42.86	6.30	110.88	40.99
42.90	3.53	111.90	3.03
43.87	1.39	112.93	14.23
44.88	11.91	113.94	1.83
45.88	1.06	114.90	1.04
46.82	6.18	129.92	1.92
46.88	3.27	130.91	6.66
47.83	1.18	131.83	89.35
49.87	1.36	132.85	13.18
50.87	10.67	136.88	9.31
51.89	2.61	137.89	96.26
52.90	12.83	138.90	11.79
53.91	11.45	139.90	1.87
54.92	23.52	142.93	1.17
55.93	4.50	156.87	4.68
56.89	2.45	157.92	2.88
58.90	10.07	158.87	0.68
63.89	5.13	159.83	44.02
64.87	34.41	160.83	57.11
65.92	2.32	161.84	1.96
66.86	1.89	174.86	1.31
66.95	16.34	187.84	100.00
67.95	6.57	188.84	5.81
68.95	2.70	192.84	1.37
70.93	4.71	193.85	1.90
71.94	5.41	214.84	1.77
72.94	10.37	221.85	1.54
74.91	1.95	242.85	4.45
75.90	1.03	249.86	12.76
76.92	32.57	250.87	1.59
77.93	2.27	269.84	1.92
78.95	6.90	270.85	9.47
79.95	1.34	271.86	1.19
80.87	41.62		
80.97	12.52		
81.89	29.20		
82.89	18.27		
82.99	7.67		
83.89	4.94		
84.93	7.14		
85.94	2.24		
88.91	1.42		
89.92	10.14		
90.91	14.45		
91.92	2.66		
92.91	27.28		
93.93	2.33		
94.92	2.29		
95.91	1.23		
96.92	2.58		
97.93	0.43		
98.93	1.39		
100.86	16.98		
102.90	3.85		
103.92	2.05		

Spectrum No.15 (CI+)

NCP34884* x1 Bgd=2 31-JAN-92 10:25:00:42 70E C1+
 BpM=0 I=5.1v Hw=536 TIC=147885008 Acnt: Sys:ACE HMR: 28743000
 N. PARKINSON PT= 0° Cal: PFK31JAN MASS: 227

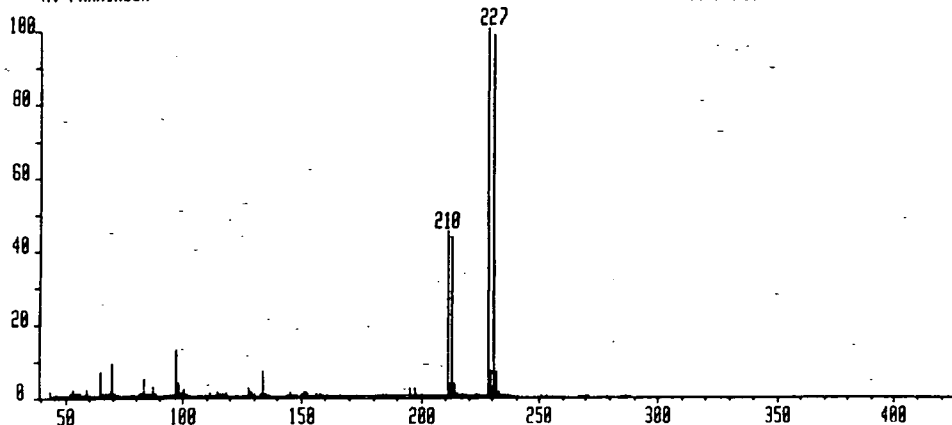

Mass	% Base
51.96	1.53
57.97	1.53
63.99	6.14
68.97	8.59
85.99	2.40
96.00	12.27
96.99	3.32
131.97	6.44
148.99	7.67
193.88	1.60
195.88	1.57
209.83	45.46
210.84	3.07
211.83	44.50
212.85	3.07
226.86	100.00
227.87	6.44
228.87	98.17
229.88	6.14

Spectrum No.16(CI+)

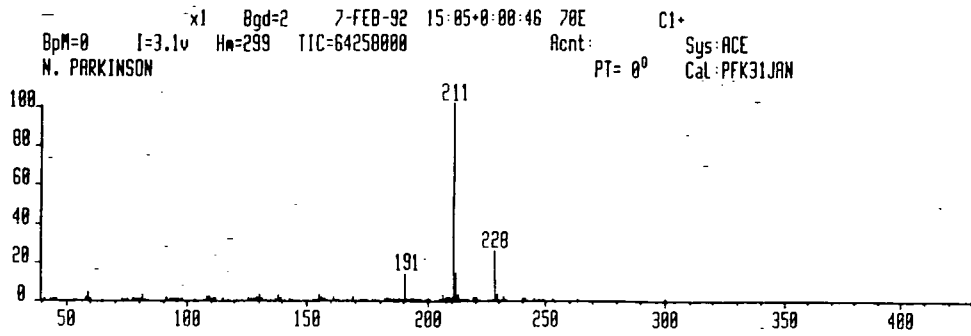

Mass	% Base
57.96	1.53
58.96	4.03
80.97	3.09
90.96	2.03
129.97	4.67
137.99	4.18
155.01	4.87
190.00	18.70
211.01	100.00
212.00	13.65
228.00	26.32
229.01	3.38

Spectrum No.17 (EI+)

VCP76#1335* Bgd=131E 8-SEP-90 10:39+0:18:45 70E EI+ 4.1
 BpM=0 I=4.8v Hw=269 TIC=134188000 Acnt: Sys: PARKINSC
 N. PARKINSON GC= 216 Cal: PFK17SEP

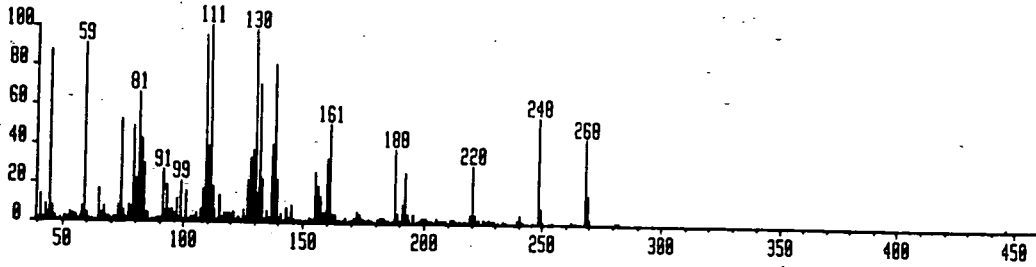

Mass	% Base	Mass	% Base
51.04	7.31	131.16	16.54
52.06	3.99	132.07	95.48
53.07	14.73	133.08	13.60
54.08	6.97	135.12	4.77
55.08	3.04	136.19	0.60
57.05	2.86	137.14	3.49
59.07	4.88	138.13	63.51
63.07	1.39	139.16	10.25
64.06	2.35	140.17	0.64
65.02	33.88	141.15	0.84
65.08	8.21	143.16	6.27
66.09	4.40	145.09	0.57
67.02	0.70	155.17	0.49
67.10	6.21	156.19	10.79
71.08	1.79	157.16	8.16
75.06	1.75	158.19	2.20
76.07	0.37	160.11	30.27
77.08	23.38	161.12	36.80
78.09	4.64	162.14	0.81
79.10	58.10	163.16	1.37
80.11	15.02	171.14	0.93
81.02	34.00	172.15	3.50
81.12	81.63	173.16	1.38
82.03	57.65	174.15	0.50
82.12	5.33	188.16	27.82
83.04	33.92	189.18	1.14
84.05	4.03	191.16	7.97
85.08	3.77	192.16	19.59
88.07	0.56	193.17	2.59
89.09	0.98	194.16	0.71
90.09	5.14	195.17	1.94
91.09	17.39	199.18	0.76
92.11	2.41	200.19	0.38
93.07	14.48	201.19	0.73
94.08	3.27	205.18	1.45
95.09	4.67	211.18	0.36
96.09	2.43	219.20	2.45
97.10	10.36	220.21	19.27
98.12	0.54	221.22	1.40
99.12	1.62	223.22	0.58
101.05	16.68	225.21	0.42
102.09	1.34	240.23	2.11
103.10	4.40	247.26	0.60
105.11	1.70	248.25	34.37
107.12	4.37	249.26	3.90
108.12	11.49	268.27	26.55
109.10	28.86	269.28	5.88
110.09	28.42		
111.09	91.65		
112.13	11.57		
113.11	2.42		
114.10	1.69		
115.11	21.85		
116.11	1.44		
118.16	1.56		
121.13	2.68		
127.13	8.40		
128.15	24.23		
129.13	33.36		
130.15	100.00		

Spectrum No.18 (EI+)

no picture

Mass	% Base
41.02	0.35
44.03	0.75
45.02	0.51
46.04	0.66
58.03	1.12
59.02	3.91
60.02	0.33
67.02	2.56
73.03	0.49
74.02	0.32
75.04	0.55
76.99	0.46
78.00	0.71
79.01	0.52
80.02	0.62
91.00	1.19
93.01	0.39
94.01	0.43
95.99	0.39
97.96	0.49
106.99	0.31
108.00	1.79
110.98	1.28
112.00	0.64
114.97	0.40
120.98	0.32
125.96	1.29
126.96	0.47
127.98	0.65
128.98	0.98
129.98	2.56
131.00	0.62
136.99	0.37
137.96	2.56
138.98	1.28
142.97	0.35
154.96	2.56
155.99	1.33
156.97	0.54
161.02	1.50
168.97	1.28
171.96	0.32
181.96	0.44
182.96	18.14
183.97	1.28
187.93	1.28
188.92	25.59
189.93	1.45
198.95	2.56
199.93	1.28
233.94	3.16
234.95	0.69
238.95	0.77
248.95	0.46
250.94	0.30
252.93	0.79
254.92	3.84
255.94	100.00
256.95	12.80
257.94	2.50
258.92	1.21

Spectrum No.19 (CI+)

NCP348#3* x1 Bgd=2 7-FEB-92 15:05:00:46 70E C1+
 BpM=0 I=3.1v Ha=376 TIC=64258000 Acnt: Sys:ACE HMR: 31234000
 N. PARKINSON PT= 0° Cal: PFK31JAN MASS: 283

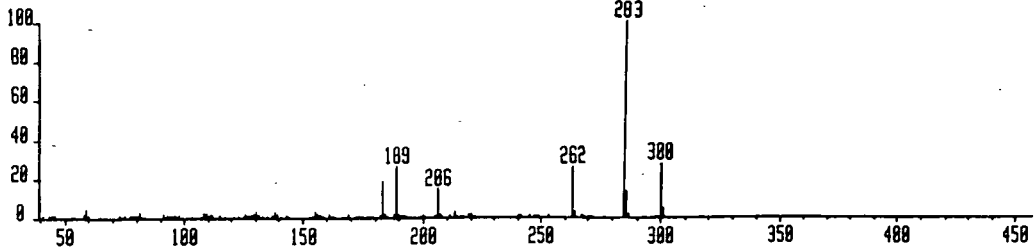

Mass	% Base
58.03	1.12
59.02	3.91
94.99	2.56
95.99	1.19
108.00	1.79
108.98	1.63
125.96	1.29
124.98	1.28
129.98	2.56
137.96	2.56
138.98	1.28
142.97	2.56
154.96	2.56
155.99	1.33
182.96	18.15
183.94	1.28
187.93	1.28
188.92	25.59
189.93	1.45
205.94	14.16
206.94	1.28
261.92	31.00
262.94	3.16
281.92	3.84
282.92	100.00
283.94	12.80
284.95	2.50
299.96	35.67
300.93	6.34

Spectrum No.20(CI+)

NCP32914* x1 Bgd=1 5-FEB-92 14:19:0:00:41 70E EI+
 BpM=0 I=0.5v Hm=326 TIC=117072000 Acnt: Sys:ACE HMR: 5536000
 N. PARKINSON PT= 0° Cal:PFK31JAN MASS: 45

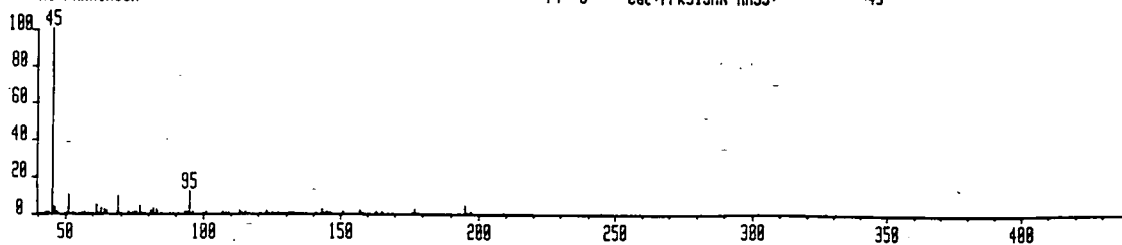

NCP32915* x1 Bgd=2 5-FEB-92 14:19:0:00:46 70E CI+
 BpM=0 I=2.4v Hm=194 TIC=55904000 Acnt: Sys:ACE HMR: 15076000
 N. PARKINSON PT= 0° Cal:PFK31JAN MASS: 45

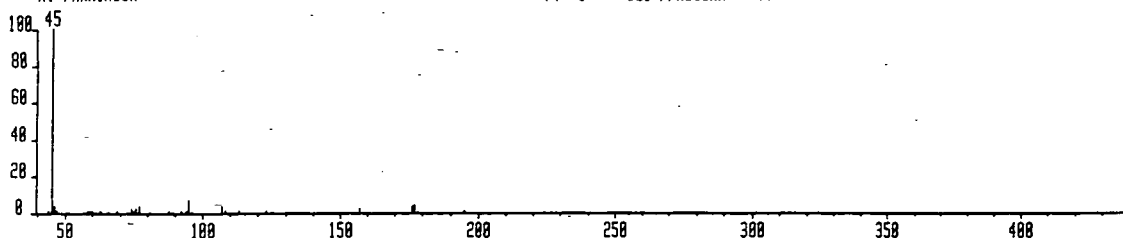

NCP32916* x1 Bgd=3 5-FEB-92 14:19:0:00:52 70E CI-
 BpM=0 I=553mv Hm=411 TIC=12711000 Acnt: Sys:ACE HMR: 3625000
 N. PARKINSON PT= 0° Cal:PFK31JAN MASS: 127

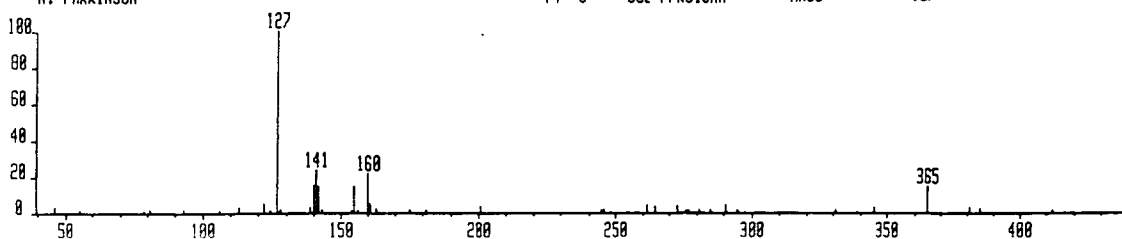

Mass	% Base
44.04	0.58
45.02	100.00
46.03	2.94
47.04	0.59
58.04	0.49
59.03	0.45
60.03	0.83
63.01	0.94
68.98	0.84
74.03	1.86
74.99	0.39
76.01	1.61
77.00	3.22
88.05	0.33
92.01	0.77
94.00	0.81
94.99	6.61
107.00	3.22
108.04	0.36
112.97	0.83
122.97	0.38
156.98	1.61
175.98	3.22
176.98	3.96
194.96	0.57

Spectrum No.21(CI+)

NCP29C#3* x1 Bgd=1 6-MAR-98 16:28:00:31 78E EI+
 BpM=0 I=3.3v Hm=684 TIC=256855000 Acnt: Sys:ACE HMR: 21782000
 N.PARKINSON PT= 8⁰ Cal:PFK2MAR MASS: 45

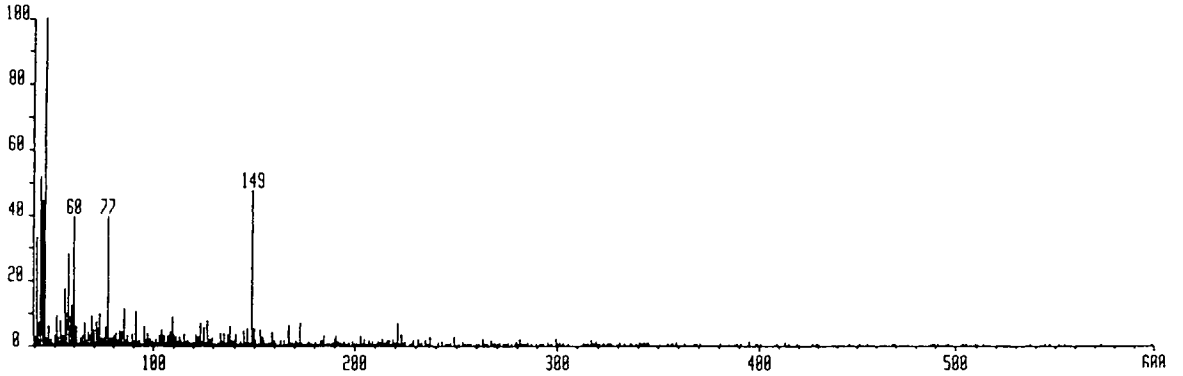

NCP29C#8* x1 Bgd=6 6-MAR-98 16:28:00:52 78E CI+
 BpM=0 I=18v Hm=549 TIC=485250016 Acnt: Sys:ACE HMR: 65534000
 N.PARKINSON PT= 8⁰ Cal:PFK2MAR MASS: 78

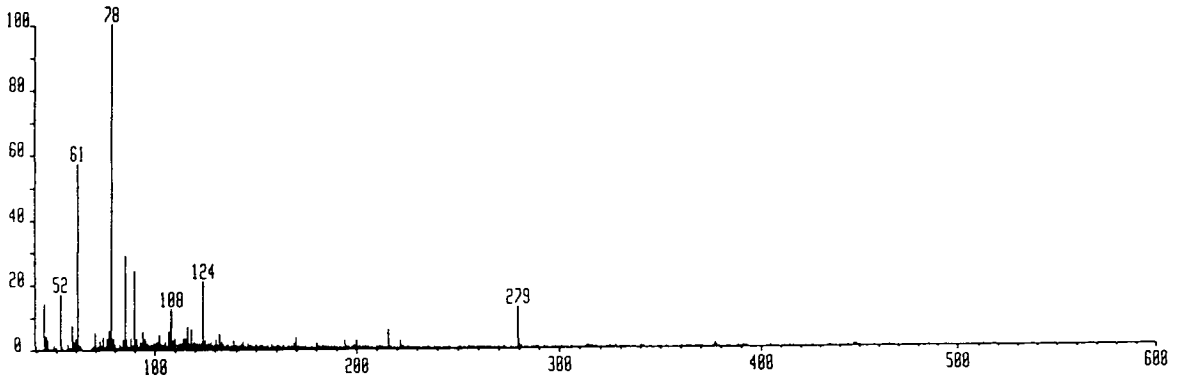

Mass	% Base	Mass	% Base
44.02	14.08	111.02	1.33
45.02	3.89	112.03	1.82
46.04	2.83	113.02	1.88
49.05	1.04	114.02	3.20
52.06	16.78	115.02	3.31
56.02	1.37	116.02	6.93
58.03	7.30	117.04	1.77
59.03	2.09	118.02	5.96
60.01	3.06	119.03	1.65
60.05	1.91	120.02	2.15
61.00	56.96	121.01	1.81
62.01	1.24	122.02	1.81
70.02	5.11	123.02	2.01
72.03	2.49	124.01	20.66
73.03	1.01	125.02	2.62
74.02	3.69	126.02	1.30
76.00	3.32	127.02	1.69
77.02	5.77	128.03	2.25
78.03	100.00	129.02	1.04
79.02	3.27	130.04	2.75
80.01	1.51	131.04	1.57
82.02	1.55	132.03	4.75
84.02	2.78	133.03	2.24
85.02	28.69	134.03	1.57
86.03	2.73	135.02	1.21
88.02	3.08	136.02	1.37
89.03	1.01	138.03	1.13
90.01	23.83	139.03	2.39
91.03	3.38	140.02	1.04
93.01	2.11	143.00	1.29
94.01	5.27	144.04	2.06
95.01	3.26	146.02	1.82
96.02	1.70	147.04	1.04
97.02	1.23	150.01	1.38
98.03	1.45	158.04	1.30
99.03	1.67	166.02	1.15
100.04	1.88	169.03	1.63
101.02	2.04	170.09	3.70
102.04	4.32	180.04	1.53
103.03	1.84	181.01	1.65
104.02	1.47	183.00	1.23
105.04	1.99	194.02	2.60
106.01	1.18	200.04	2.43
107.03	5.28	215.99	5.70
108.02	12.10	222.00	2.39
109.02	2.37	279.03	12.65
110.02	3.07		

Spectrum No.22 (CI+)

NCP331#5* x1 Bgd=1 31-JAN-92 11:37:0:00:47 70E EI+
 BpM=0 I=10v Hw=205 TIC=294542016 Acnt: Sys:ACE HMR: 65534000
 N. PARKINSON PT= 0° Cal: PFK31JAN MASS: 71

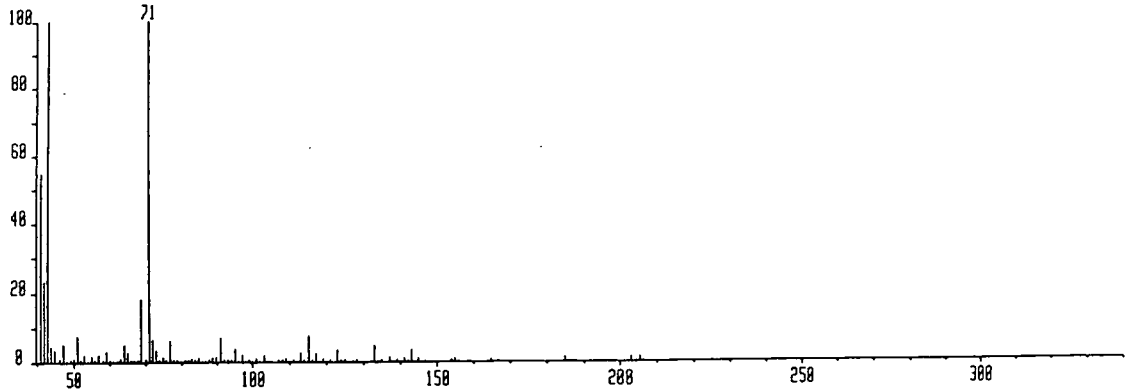

NCP331#6* x1 Bgd=2 31-JAN-92 11:37:0:00:52 70E CI+
 BpM=0 I=10v Hw=205 TIC=138409000 Acnt: Sys:ACE HMR: 40960000
 N. PARKINSON PT= 0° Cal: PFK31JAN MASS: 71



Mass	% Base
41.01	3.52
42.02	0.39
43.03	1.56
44.02	0.52
56.02	0.60
58.04	6.76
59.02	0.71
68.98	0.42
70.02	0.39
71.01	62.50
72.02	2.98
73.01	0.39
74.01	0.40
76.98	0.90
88.03	0.78
89.98	0.39
90.99	0.45
94.00	0.39
94.97	0.49
97.00	0.39
98.98	0.39
102.98	0.39
112.95	0.39
114.99	0.78
116.99	0.45
124.98	0.46
144.97	0.42
152.99	0.41
163.97	0.49
164.97	0.78
183.96	3.10
184.97	1.70
221.98	0.49

Spectrum No.23 (EI+)

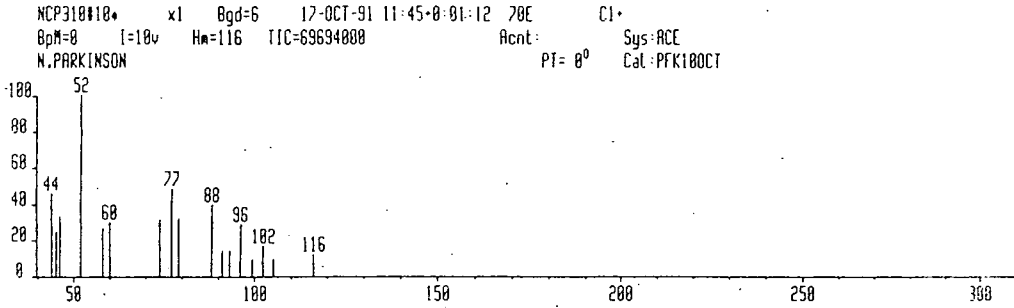
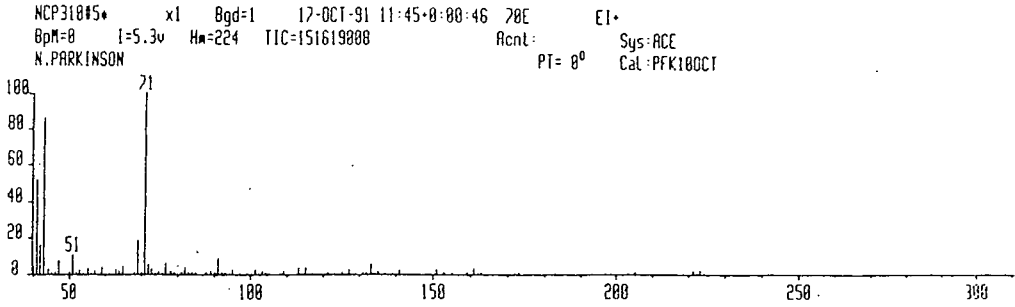

Mass	% Base
40.03	4.03
41.04	51.48
42.01	3.14
42.05	15.61
43.06	85.82
44.05	2.72
47.04	7.24
50.02	0.76
51.02	10.49
52.04	0.34
53.05	1.72
55.07	2.28
57.03	1.59
59.05	3.48
63.03	1.61
64.04	1.49
65.05	3.61
68.04	0.36
69.02	18.05
70.05	0.61
71.07	100.00
72.08	4.87
73.07	2.43
75.03	1.47
77.05	5.90
82.03	2.99
89.05	1.05
90.06	0.86
91.07	8.16
95.05	1.91
101.05	1.62
103.08	1.50
104.08	0.33
109.07	1.32
113.04	2.90
115.08	3.01
127.07	1.76
131.05	0.51
132.06	0.33
133.07	5.15
135.09	1.54
141.05	1.82
151.06	2.05
161.07	2.62
221.13	1.47
223.15	1.67

Spectrum No.24 (EI+)

NCPFFP#702* x1 Bgd=692 10-APR-92 15:51:08:00:43 70E EI+
 BpM=0 I=3.0v Ha=221 TIC=130300000 Acnt: Sys: PARKINSON HMR: 19456000
 FA3 0.1MSEC GC= 116° Cal: PFK10APR MASS: 133

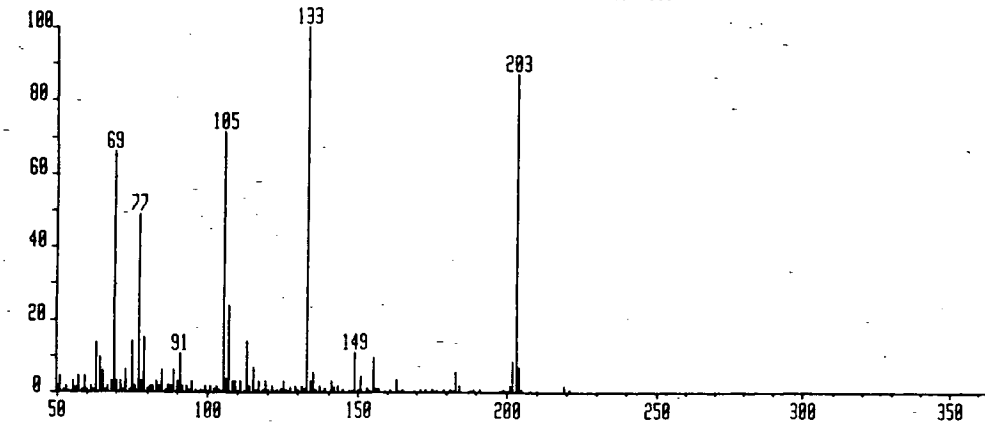

Mass	% Base	Mass	% Base
49.00	4.14	151.02	3.95
50.03	1.32	155.08	9.35
51.03	4.28	163.08	3.08
53.05	1.51	183.09	5.26
55.04	2.63	184.10	1.32
56.04	1.02	201.06	1.32
57.04	3.95	202.08	8.05
59.05	3.95	203.09	86.89
61.02	1.38	204.10	6.58
63.01	13.39	205.12	0.31
64.03	9.21	219.09	1.32
65.02	5.46		
67.01	1.32		
68.04	2.63		
69.02	65.79		
70.05	2.63		
71.05	2.68		
73.02	5.90		
75.02	13.62		
76.02	1.32		
77.03	48.78		
78.03	2.63		
79.03	14.72		
81.03	1.32		
82.02	1.32		
83.05	2.63		
84.07	1.32		
85.00	5.77		
86.99	1.64		
88.04	1.32		
89.04	5.69		
90.05	2.63		
91.05	10.11		
92.06	1.32		
93.03	1.32		
95.04	2.63		
99.03	1.32		
101.05	1.32		
103.06	1.32		
105.04	71.18		
106.04	3.26		
107.03	23.68		
108.04	2.63		
109.05	2.63		
111.02	2.73		
113.03	13.71		
114.05	1.32		
115.07	6.58		
117.05	2.88		
119.05	2.63		
121.06	1.32		
125.03	2.63		
127.03	1.02		
129.03	1.32		
131.03	1.32		
133.04	100.00		
134.05	2.84		
135.07	5.26		
137.04	1.33		
141.05	2.63		
142.05	1.00		
143.05	1.32		
149.01	10.53		

Spectrum No.25 (EI+)

NCPTFE#1067* x1 Bgd=897 10-APR-92 12:39:08:13:14 70E EI+
 BpM=0 I=175mv Hm=224 TIC=12329000 Acnt: Sys: PARKINSON HMR: 1152000
 FR3 0.1MSEC GC= 161° Cal: PFK10RPR MASS: 221

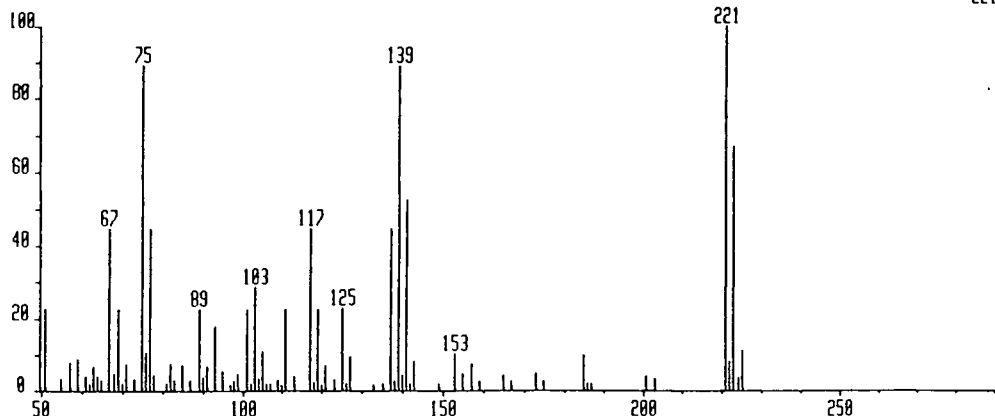

Mass	% Base	Mass	% Base
47.98	2.00	137.98	2.43
48.99	22.22	138.96	88.98
50.00	2.08	139.96	4.17
51.01	22.22	140.95	52.34
55.01	3.13	141.95	1.56
57.01	7.64	142.95	7.90
59.03	8.51	149.00	1.56
60.98	3.65	152.95	10.07
61.99	1.74	154.96	4.43
62.98	6.60	156.98	7.03
64.01	3.73	158.98	2.43
64.97	2.34	164.98	4.08
65.02	2.69	166.97	2.26
66.97	44.44	172.96	4.34
68.02	4.51	174.96	2.26
68.98	22.22	184.98	9.64
70.01	1.56	185.98	1.65
71.02	7.29	186.99	1.56
72.98	2.95	200.94	3.73
74.99	88.89	202.94	3.13
75.99	10.24	220.95	100.00
76.99	44.44	221.95	7.81
77.99	4.08	222.95	66.75
81.00	1.82	223.95	3.30
81.99	7.29	224.95	10.94
82.94	2.60		
83.01	2.60		
84.95	6.77		
86.97	2.78		
89.01	22.22		
90.02	3.47		
90.99	6.60		
92.98	17.45		
94.99	5.03		
96.95	1.48		
97.97	2.26		
99.01	4.43		
101.01	22.22		
102.02	1.74		
102.99	28.39		
103.99	2.95		
104.99	10.68		
105.99	1.74		
106.99	1.74		
108.95	2.78		
109.96	1.39		
110.96	22.22		
112.96	3.73		
116.97	44.44		
117.96	2.17		
119.00	22.22		
119.96	1.22		
121.01	6.86		
122.99	2.69		
124.98	22.48		
125.99	1.56		
126.98	9.29		
132.93	1.39		
134.97	1.56		
136.98	44.44		

Spectrum No.26(EI+)

NCP308*1269* x1 Bgd=1255 17-FEB-92 12:39:0.13:14 70E EI+
SpM=0 I=6.1v Hn=308 TIC=66033000 Acnt: Sys: PARKINSON
FR3 0.1MSEC GC= 161° Cal: PFK31JAM

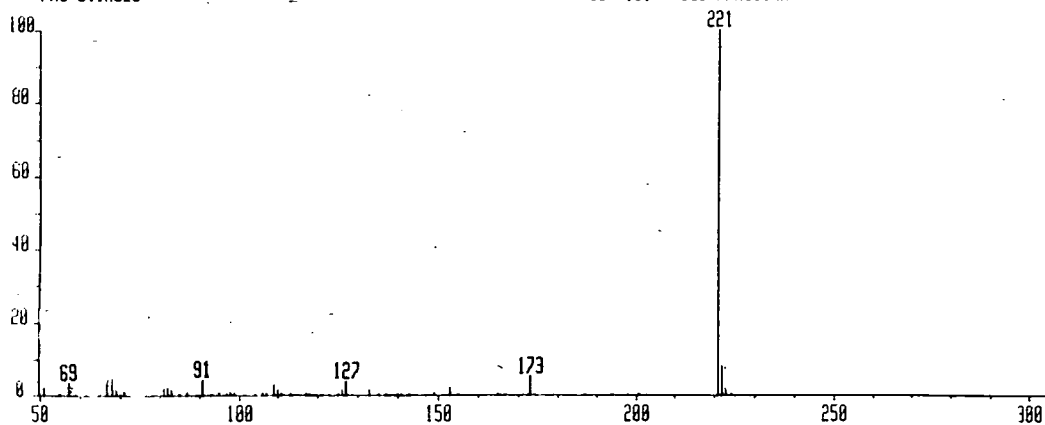

Mass	% Base
51.01	1.67
57.03	1.28
59.04	3.84
65.03	1.73
69.02	4.73
77.03	1.95
87.05	2.02
91.04	3.58
109.03	1.33
127.03	6.48
133.04	1.71
153.05	2.32
173.05	3.41
221.04	100.00
222.05	7.72

Spectrum No.27 (FAB+)

NCP431#11* x1 Bgd=1 5-MAY-92 14:36:0:01:42 78E FB+
 BpM=0 I=3.9v Hm=878 TIC=182668888 Acnt: Sys:FAB HMR: 25740888
 NIGEL PARKINSON PT= 0° Cal:PFKSMAY MASS: 113

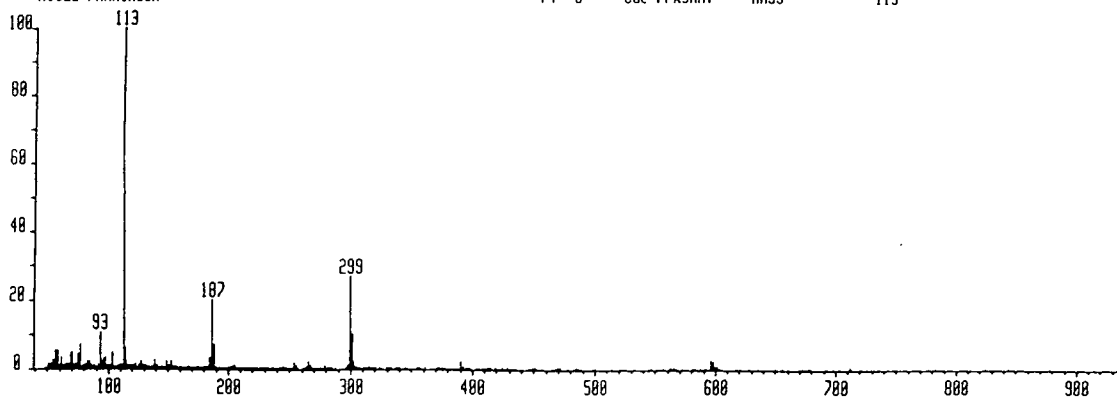

NCP431#28* x1 Bgd=6 5-MAY-92 14:36:0:02:47 78E FB-
 BpM=0 I=131uv Hm=859 TIC=6223888 Acnt: Sys:FAB HMR: 864888
 NIGEL PARKINSON PT= 0° Cal:PFKSMAY MASS: 297

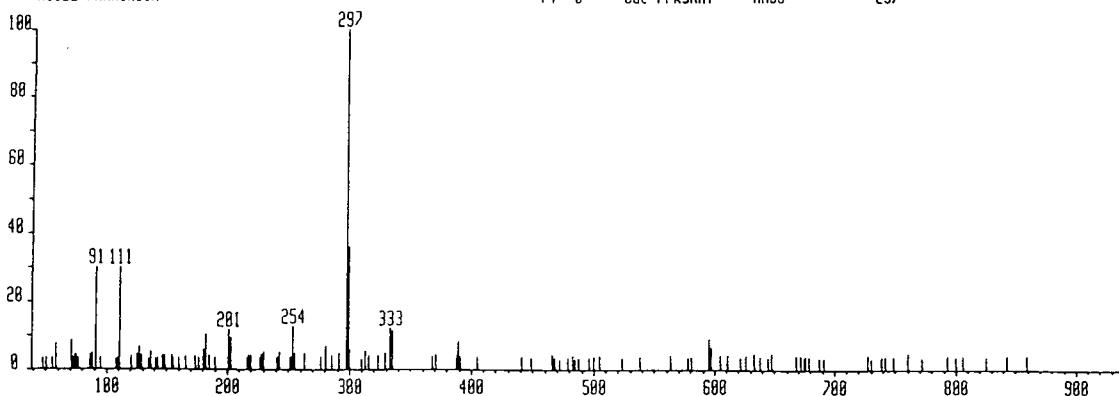

Mass	% Base	Mass	% Base
50.88	1.20	253.89	1.88
52.91	1.34	264.94	1.99
53.91	1.18	265.94	0.37
54.91	2.37	266.96	1.04
55.92	1.22	297.88	1.02
56.93	5.26	298.87	26.81
58.93	5.16	299.88	5.97
60.94	2.98	300.87	9.95
62.92	1.08	301.88	1.99
64.94	1.27	302.90	0.63
66.95	1.23	596.73	2.31
67.97	1.17	597.73	0.99
68.97	4.34	598.72	1.99
69.97	4.28		
70.99	1.17		
71.99	1.01		
72.99	1.22		
74.98	4.11		
76.98	6.96		
83.00	1.99		
84.00	1.03		
85.00	1.99		
91.00	1.09		
92.99	10.16		
94.00	0.72		
94.98	1.99		
95.98	2.59		
97.00	3.19		
102.99	4.55		
111.98	1.13		
112.98	100.00		
113.98	5.97		
114.98	1.99		
116.97	1.06		
118.96	1.11		
126.98	1.99		
138.98	2.32		
148.96	1.99		
152.98	1.99		
184.98	2.98		
185.96	0.54		
186.92	19.89		
187.92	1.99		
188.91	6.96		

Spectrum No.28 (FAB+)

rds0220001 Scan 6 RT=0:34 100%=129490 mv 7 Jul 93 15:12
LRP +FAB NCP 77 718708 POS-FAB-MS GLY

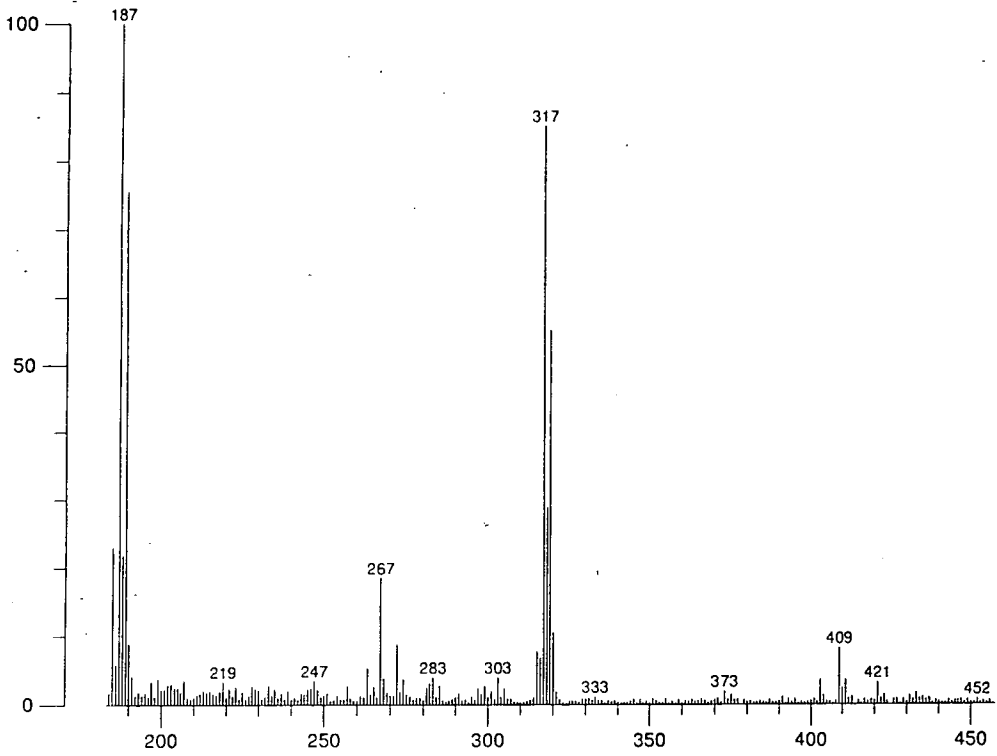

no numeric data

Spectrum No.29 (FAB+)

NCP435110* x1 Bgd=6 5-MAY-92 14:51:0:01 35 28E FB-
 BpM=0 I=195µv Hw=868 TIC=9392000 Acnt: Sys:FAB HMR: 1200000
 NIGEL PARKINSON PT= 0° Cal:PFK5MAY MASS: 313

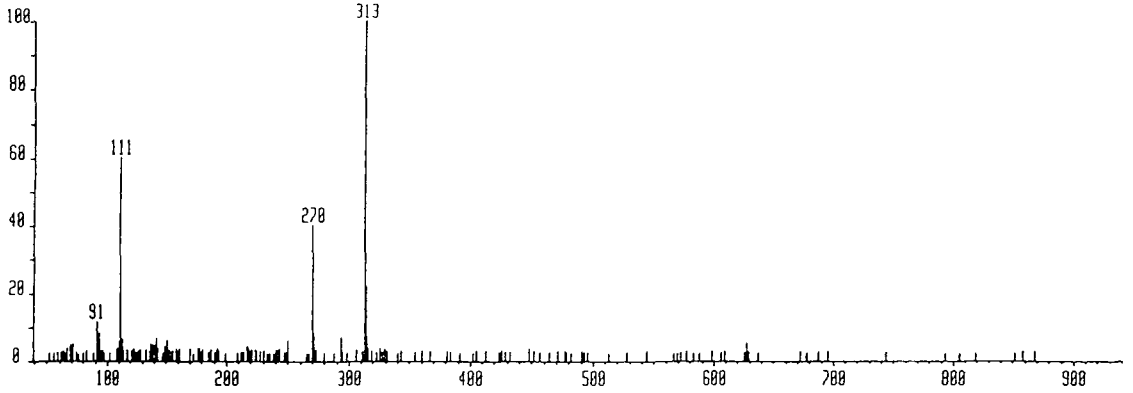

NCP435110* x1 Bgd=1 5-MAY-92 14:51:0:01:42 28E FB-
 BpM=0 I=10v Hw=866 TIC=252554000 Acnt: Sys:FAB HMR: 65407000
 NIGEL PARKINSON PT= 0° Cal:PFK5MAY MASS: 113

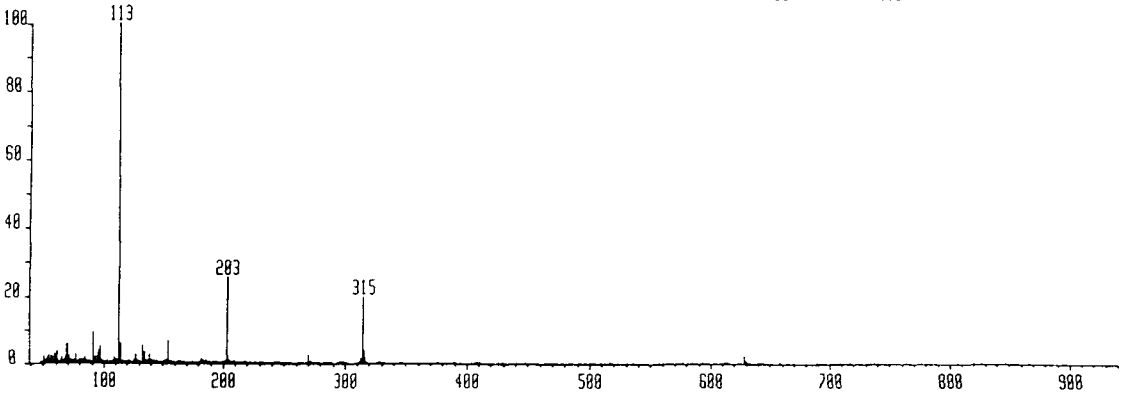

Mass	% Base	Mass	% Base
50.89	1.94	154.98	6.65
51.90	0.78	182.97	1.24
52.91	1.17	202.95	25.45
53.92	1.86	203.96	2.04
54.92	2.45	269.92	2.44
55.93	1.16	312.89	1.56
56.93	1.95	313.90	1.17
57.95	1.56	314.90	19.53
58.94	2.74	315.90	3.78
60.95	3.32	316.93	1.56
64.96	1.56	317.93	0.38
66.98	1.17		
67.98	1.95		
68.97	5.60		
69.98	5.55		
70.99	1.92		
72.00	1.17		
74.99	1.17		
76.99	2.35		
80.01	1.17		
82.02	1.17		
83.01	1.17		
84.01	1.17		
85.01	1.56		
91.00	8.99		
92.01	0.78		
93.02	1.56		
94.01	0.78		
94.99	2.70		
95.99	3.91		
97.00	4.85		
98.01	1.17		
109.00	1.62		
111.99	1.17		
112.99	100.00		
113.99	5.86		
114.99	5.86		
126.00	1.17		
126.99	2.35		
132.96	5.08		
133.99	0.41		
134.99	3.13		
138.99	2.35		

Spectrum No.30 (FAB+)

rds0210001 Scan 6 RT=0:33 100%=142260 mv 7 Jul 93 15:06
LRP +FAB NCP 78 718707 POS-FAB-MS.GLY

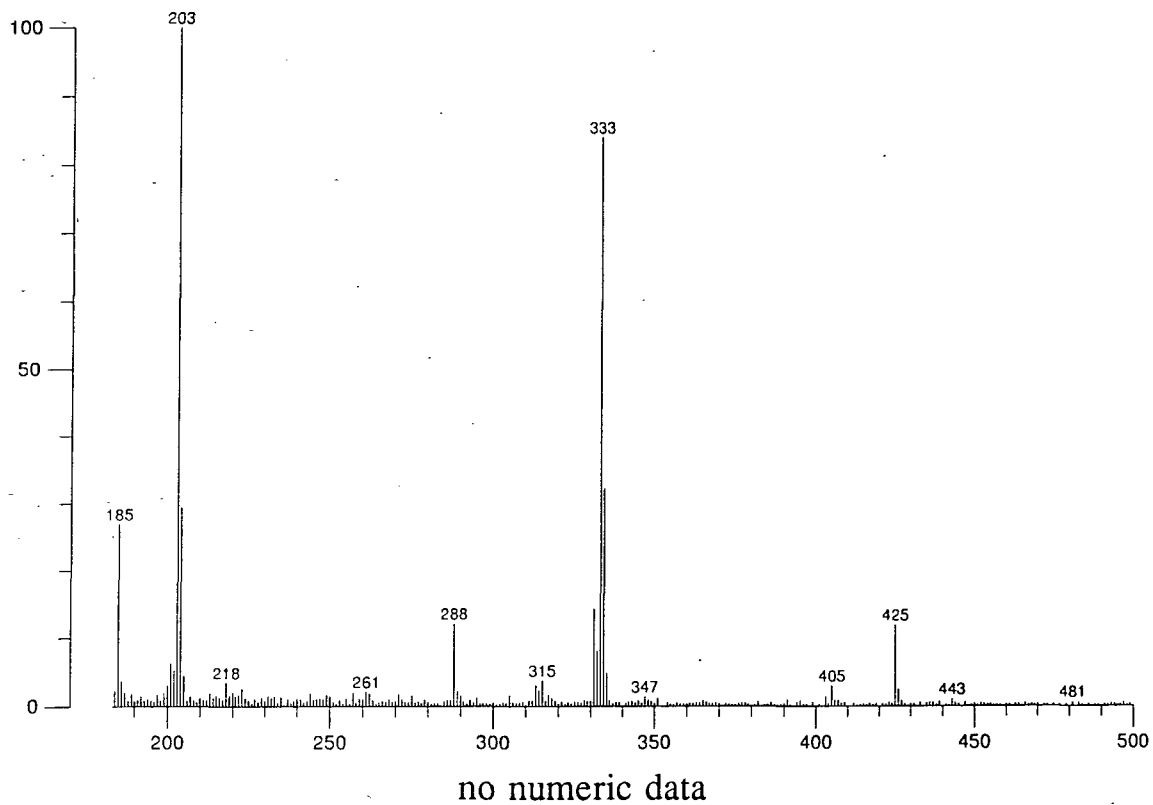

Spectrum No.31(FAB+)

NCP424118* x1 Bgd=6 5-MAY-92 11:45:01:35 70E FB-
 BpM=0 I=239mV Hw=888 TIC=6903000 Acnt: Sys:FAB HMR: 1570000
 NIGEL PARKINSON PT= 0° Cal:PFKSMAY MASS: 331

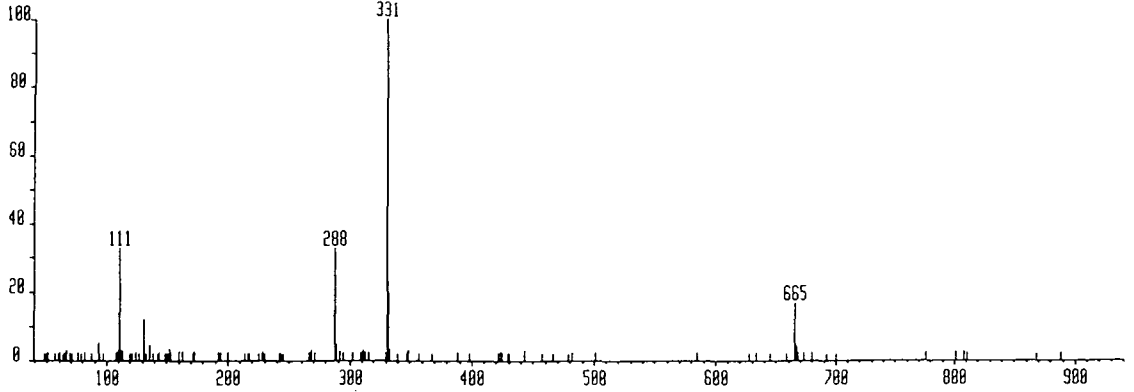

NCP424111* x1 Bgd=1 5-MAY-92 11:45:01:43 70E FB-
 BpM=0 I=10v Hw=891 TIC=251822000 Acnt: Sys:FAB HMR: 65534000
 NIGEL PARKINSON PT= 0° Cal:PFKSMAY MASS: 113

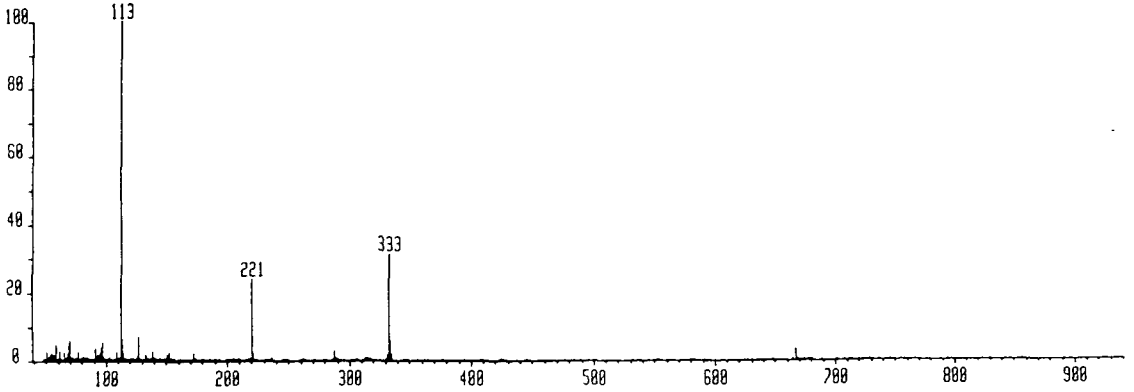

Mass	% Base	Mass	% Base
49.21	3.58	268.48	3.08
51.96	3.08	287.98	35.39
54.13	3.58	289.00	5.18
65.94	4.93	308.89	3.58
74.42	3.82	311.05	6.41
77.89	3.21	311.64	4.56
82.99	3.95	313.05	3.82
83.04	3.95	320.24	3.58
91.01	5.55	331.02	100.00
92.97	8.63	332.06	31.57
93.36	3.33	353.75	3.58
95.07	3.21		
95.97	4.44		
107.00	4.07		
108.01	5.92		
108.97	4.93		
110.98	53.13		
111.98	6.04		
112.95	4.07		
115.02	4.56		
122.03	2.96		
124.80	3.08		
130.55	4.07		
130.97	14.55		
136.03	5.18		
152.30	3.33		
152.36	3.70		
159.37	3.70		
159.98	4.93		
160.80	3.58		
172.99	3.33		
181.04	3.45		
184.31	3.21		
199.02	3.33		
199.90	4.07		
201.88	3.45		
212.99	5.30		
215.96	3.58		
221.00	4.07		
226.00	3.45		
228.04	4.44		
229.00	4.44		
254.33	3.21		
261.25	3.33		

Spectrum No.32 (FAB+)

NCP42315 x1 Bgd=1 5-MAY-92 12:43-0:00:59 78E FB+
 BpM=0 I=664uv Hw=879 TIC=31687000 Acnt: Sys:FAB HMR: 4352000
 NIGEL PARKINSON PT= 0° Cal:PFKSMAY MASS: 131

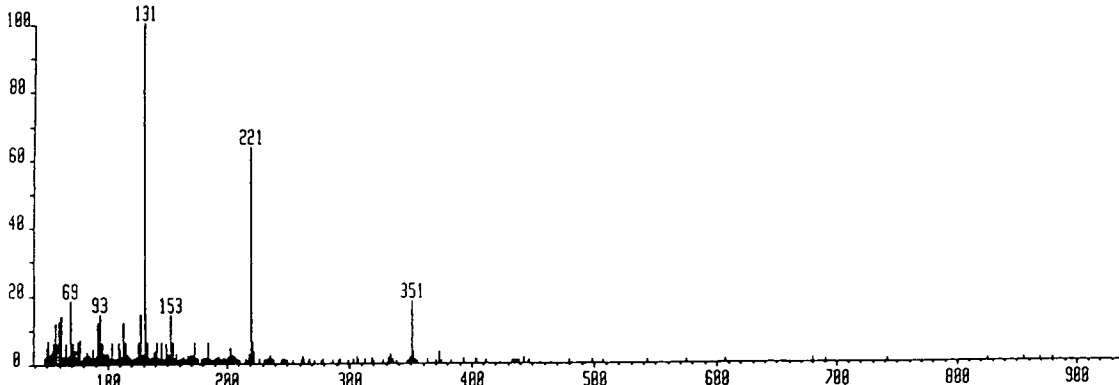

NCP42316 x1 Bgd=6 5-MAY-92 12:43-0:01:06 78E FB-
 BpM=0 I=46uv Hw=888 TIC=2839000 Acnt: Sys:FAB HMR: 306800
 NIGEL PARKINSON PT= 0° Cal:PFKSMAY MASS: 349

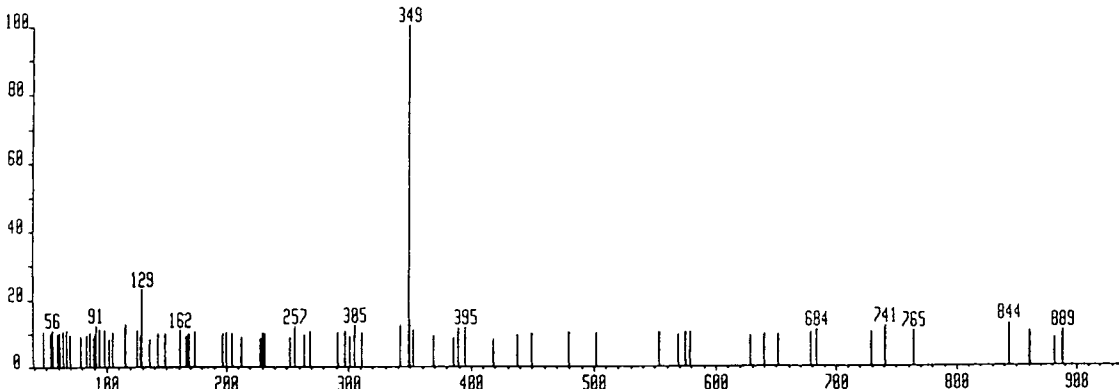

Mass	% Base	Mass	% Base	Mass	% Base	Mass	% Base
47.89	1.82	98.01	2.27	149.00	5.35	353.08	0.87
49.87	4.43	99.02	2.78	150.96	2.46	354.96	0.76
50.88	6.43	99.98	2.25	152.01	1.95	362.99	1.01
52.91	2.87	101.00	1.17	153.01	13.65	369.72	0.80
53.91	3.26	102.01	1.49	154.03	2.44	372.99	3.08
54.91	5.88	103.01	5.88	155.00	5.88		
55.92	5.70	104.02	1.15	156.01	1.26		
56.93	11.76	105.01	1.52	157.01	2.46		
57.94	5.88	106.01	1.03	167.02	1.98		
58.94	12.20	107.01	1.29	168.05	1.52		
59.94	4.62	108.02	1.06	169.00	2.09		
60.94	13.58	109.00	5.88	170.01	0.67		
61.94	1.29	110.03	3.88	171.02	2.00		
62.94	1.93	111.02	1.72	173.00	5.88		
64.96	5.88	111.99	1.86	173.98	1.10		
66.99	1.98	113.00	11.76	175.01	1.47		
67.98	2.37	113.98	5.88	175.99	1.15		
68.96	18.15	115.00	5.88	180.97	1.54		
69.97	5.88	116.00	1.42	182.00	0.76		
70.99	5.88	117.02	2.37	183.03	1.33		
71.99	2.21	118.98	1.72	184.01	1.06		
72.99	3.63	121.00	1.19	185.03	5.88		
73.99	1.79	121.98	1.38	201.01	1.77		
75.00	6.30	123.02	1.79	203.01	4.23		
76.00	1.13	124.01	1.33	205.02	1.93		
76.99	6.87	125.00	5.88	207.05	1.70		
80.02	2.00	126.01	1.75	218.99	2.32		
81.02	1.56	126.98	13.90	220.01	1.42		
82.00	2.11	128.01	1.56	220.98	63.30		
83.01	3.13	129.00	2.25	222.00	5.88		
84.02	2.18	130.00	2.37	223.00	3.24		
85.02	2.23	130.99	100.00	235.00	1.49		
86.03	1.56	132.00	5.88	236.01	1.88		
87.01	1.54	132.99	5.88	262.00	1.70		
88.00	4.04	134.03	1.72	305.96	1.61		
89.00	1.70	137.01	1.65	307.01	1.10		
89.20	0.62	138.01	1.52	312.99	1.17		
90.01	2.21	139.02	3.13	319.04	1.22		
91.01	11.76	141.00	5.88	330.98	1.54		
93.02	13.95	142.01	1.36	332.99	2.55		
94.03	1.63	142.99	1.36	348.99	1.54		
95.01	5.72	144.01	1.15	349.97	1.59		
96.01	1.75	145.00	5.88	350.96	17.65		
97.01	2.67	146.03	1.19	351.99	2.92		

Spectrum No.33 (FAB+)

NCP420#17• x1 Bgd=9 5-MAY-92 11:22:0:02:25 78E FB-
 BpM=0 I=207uv Hm=891 TIC=11413000 Acnt: Sys:FAB HMR: 1002000
 NIGEL PARKINSON PT= 0° Cal:PFK5MAY MASS: 305

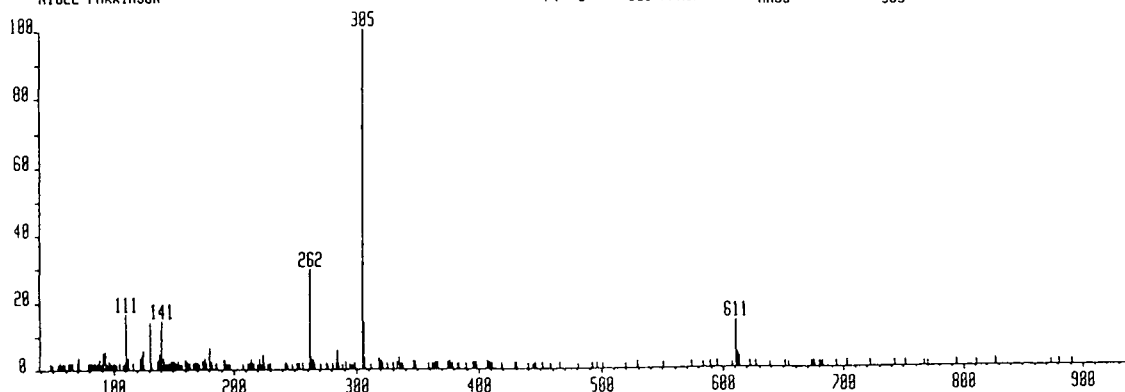

NCP420#11• x1 Bgd=5 5-MAY-92 11:22:0:01:42 78E FB+
 BpM=0 I=7.2v Hm=864 TIC=234536000 Acnt: Sys:FAB HMR: 46912000
 NIGEL PARKINSON PT= 0° Cal:PFK5MAY MASS: 307

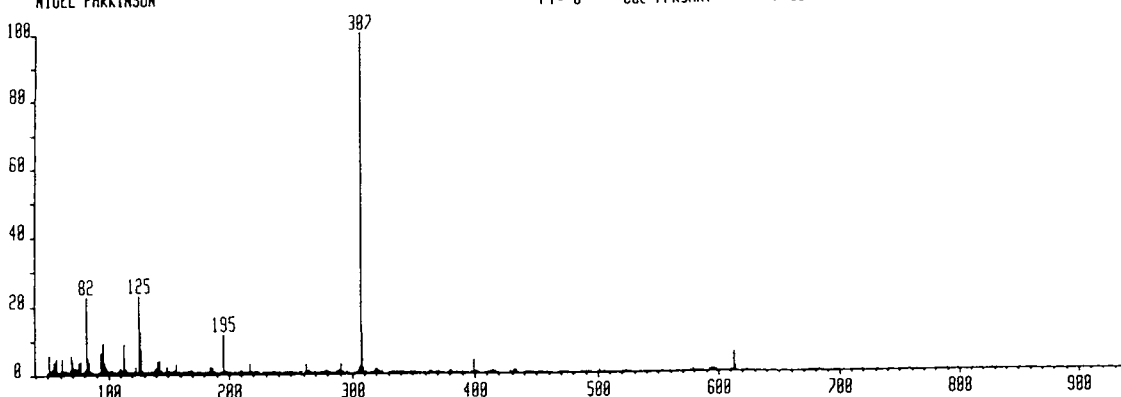

Mass	% Base	Mass	% Base
50.87	5.50	140.94	3.82
51.89	1.09	141.95	1.09
52.89	1.19	142.93	3.82
53.91	1.64	148.94	2.18
54.91	3.46	156.96	2.73
55.92	2.18	184.97	2.20
56.93	4.37	186.95	1.64
57.93	1.09	194.89	11.46
60.93	4.48	195.91	1.09
67.97	1.44	216.94	2.65
68.95	5.64	261.85	2.73
69.97	3.30	290.86	2.73
70.98	1.09	304.84	1.29
71.98	1.73	305.82	2.18
72.98	1.64	306.82	100.00
74.00	1.09	307.83	11.46
74.99	3.27	308.85	1.74
76.97	3.83	309.87	0.41
80.99	1.33	310.88	0.55
81.98	22.29		
82.98	4.37		
84.00	3.28		
84.99	1.10		
93.00	6.19		
94.96	8.74		
95.96	3.38		
96.98	2.35		
97.98	1.64		
98.99	1.14		
108.97	1.28		
109.98	1.64		
110.99	1.09		
111.97	1.10		
112.97	8.73		
113.98	1.14		
114.97	1.24		
122.94	2.18		
124.95	22.50		
125.96	11.98		
126.97	6.69		
127.98	1.09		

Spectrum No.34 (FAB+)

NCP429#110 x1 Bgd=6 5-MAY-92 11:34:08:01:35 70E FB-
 BpM=0 I=245mV Hm=876 TIC=7888000 Acnt: Sys:FAB HMR: 1687000
 NIGEL PARKINSON PT= 0° Cal:PFKSMAY MASS: 323

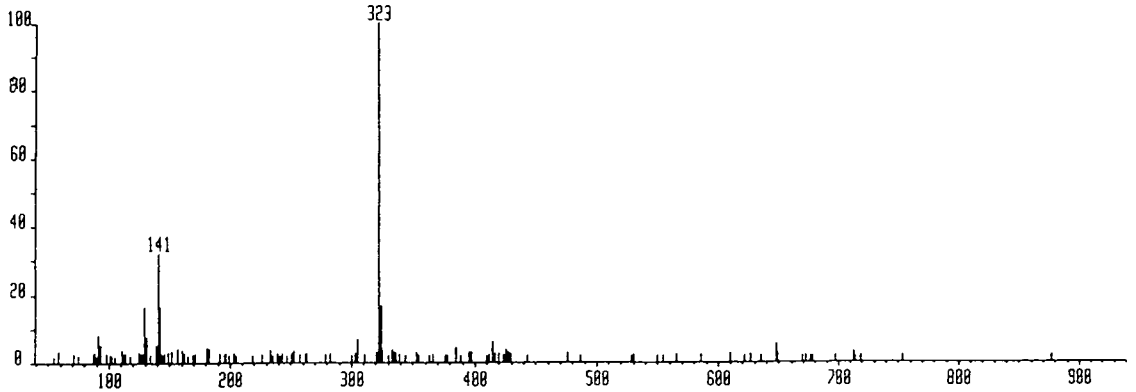

NCP429#110 x1 Bgd=4 5-MAY-92 11:34:08:01:43 70E FB-
 BpM=0 I=2.3v Hm=893 TIC=139862000 Acnt: Sys:FAB HMR: 14894000
 NIGEL PARKINSON PT= 0° Cal:PFKSMAY MASS: 93

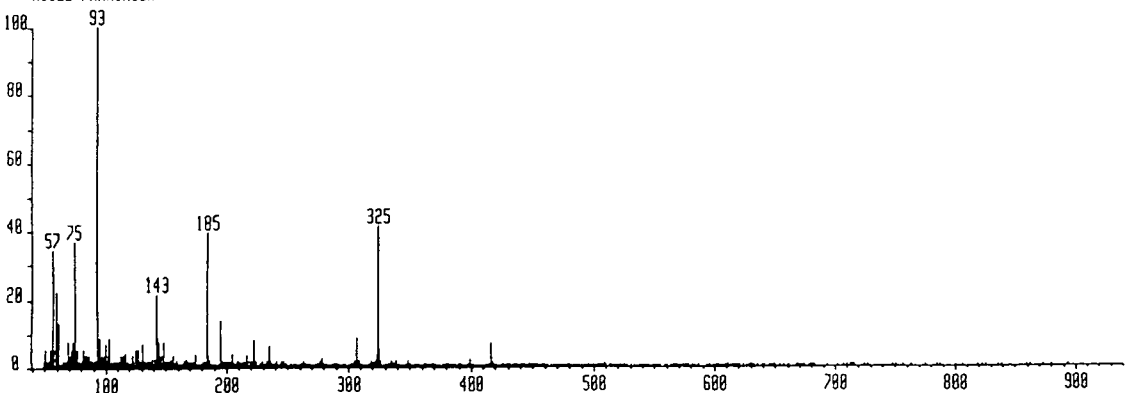

Mass	% Base	Mass	% Base	Mass	% Base	Mass	% Base
49.87	1.69	97.98	2.10	142.93	21.06	262.93	1.72
50.87	5.19	98.98	3.44	143.95	8.65	263.89	0.41
52.90	1.72	99.96	6.88	144.95	7.08	264.92	0.89
53.91	1.29	100.98	2.12	145.96	1.72	265.92	0.46
54.91	5.21	101.99	3.44	146.99	3.44	266.91	0.65
55.92	5.16	103.00	8.59	148.95	7.65	267.90	0.52
56.92	34.38	103.99	1.11	149.96	1.87	268.91	0.60
57.93	5.16	104.99	1.73	150.97	1.72	269.91	0.40
58.94	21.77	107.00	1.72	151.97	1.72	270.92	0.55
59.93	3.46	107.99	1.57	152.96	1.83	271.93	0.34
60.93	12.86	108.99	1.72	153.97	1.72	272.91	0.83
64.95	1.72	109.99	1.72	154.95	2.27	273.92	0.38
65.96	0.70	110.99	1.86	155.97	1.57	274.94	0.97
66.98	1.72	111.98	1.72	156.96	3.44	275.92	0.32
67.97	1.88	112.98	3.50	157.98	1.30	276.93	1.82
68.95	7.41	113.96	2.26	158.94	1.91	278.95	2.33
69.98	2.36	114.96	3.44	164.96	1.93	304.86	1.64
70.99	3.44	115.96	1.72	165.97	1.42	305.83	0.67
71.98	5.16	116.98	3.97	166.95	2.33	306.85	8.59
72.98	7.50	117.98	1.40	167.96	1.69	307.87	1.72
73.98	7.10	118.98	1.72	168.93	1.75	308.86	1.85
74.99	36.65	119.99	1.02	172.94	1.72	318.87	1.72
76.00	1.85	120.99	1.32	173.96	1.11	319.77	0.42
76.98	5.16	121.98	1.06	174.95	3.62	320.89	1.26
79.00	1.72	122.95	3.44	194.90	13.75	321.87	0.58
79.99	1.05	123.98	1.72	195.93	1.72	322.84	1.72
81.00	2.07	124.96	5.23	196.94	1.72	323.84	3.44
81.99	5.16	125.97	3.44	198.96	1.72	324.82	41.25
82.98	3.44	126.96	5.16	199.96	0.99	325.82	5.16
84.00	3.44	127.97	1.73	200.95	1.72	326.86	1.72
84.99	3.44	128.97	1.72	201.97	0.60	327.92	0.36
86.01	1.76	129.96	1.74	202.94	1.72		
87.00	3.44	130.95	6.88	203.98	0.66		
87.98	1.72	131.98	1.72	204.93	3.75		
88.99	1.93	132.98	1.72	228.93	1.69		
89.98	1.76	133.98	1.11	232.91	1.84		
90.99	1.97	134.98	1.72	233.89	0.48		
92.00	0.50	135.98	1.77	234.92	6.02		
93.00	100.00	136.98	1.72	235.91	1.72		
94.00	3.93	137.97	1.72	240.96	1.72		
94.97	8.59	138.96	2.39	244.91	1.72		
95.98	2.10	140.96	2.35	245.91	0.62		
96.99	3.44	141.96	1.72	246.92	1.72		

Spectrum No.35 (FAB+)

NCP34410* x1 8gd=6 5-MAY-92 10:54:0:01:21 70E FB-
 BpM=0 I=46uv Ha=893 TIC=8871888 Acnt: Sys:FAB HR: 38588
 NIGEL PARKINSON PT= 0° Cal:PFKSMAY MASS: 326

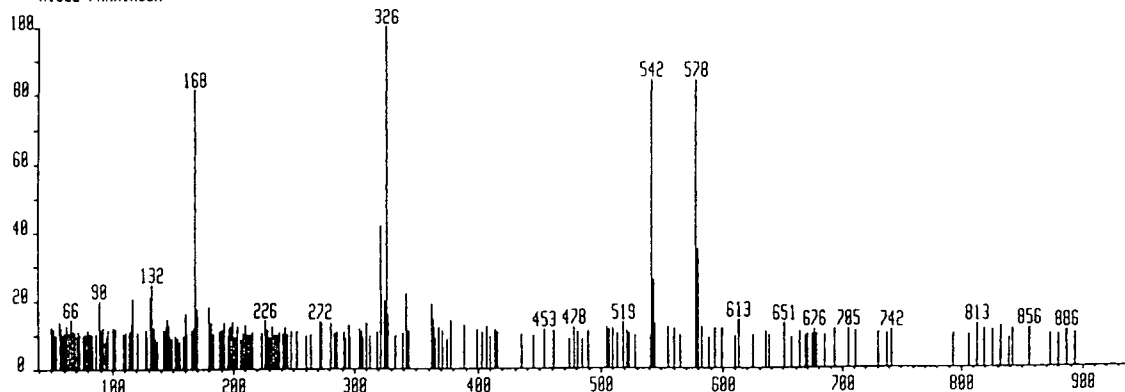

NCP34411* x1 8gd=1 5-MAY-92 10:54:0:01:42 70E FB-
 BpM=0 I=4.1v Ha=892 TIC=368166816 Acnt: Sys:FAB
 NIGEL PARKINSON PT= 0° Cal:PFKSMAY

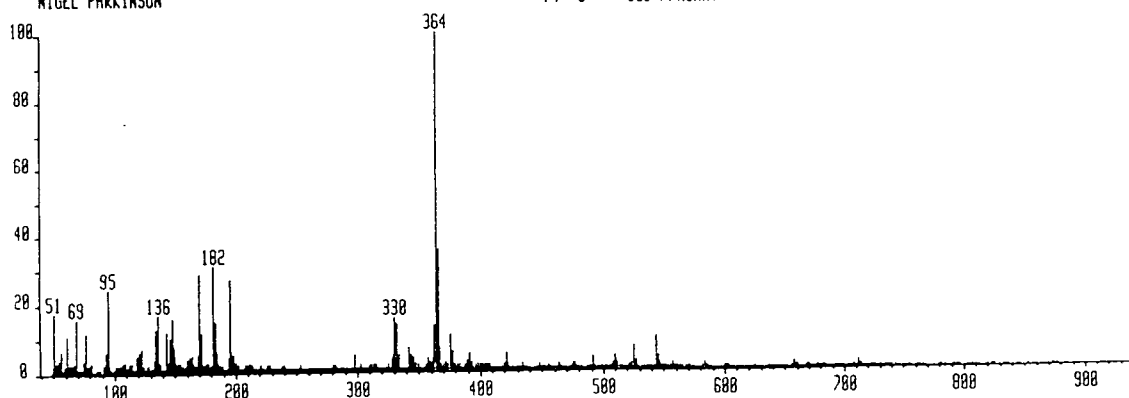

Mass	% Base	Mass	% Base	Mass	% Base
50.88	17.28	159.98	3.83	359.84	2.87
52.91	2.92	160.97	2.87	360.82	1.92
53.92	2.87	161.98	4.33	361.82	3.83
54.92	3.83	162.99	2.87	362.79	13.41
56.94	6.21	163.98	4.79	363.80	100.00
60.94	10.54	164.96	2.87	364.80	24.91
62.94	2.27	165.98	2.08	365.80	35.64
64.95	2.24	168.93	4.79	366.81	7.01
66.97	2.87	169.93	28.84	367.84	1.92
67.98	2.00	170.93	4.79	375.71	10.54
68.95	15.33	171.93	11.42	376.82	3.83
74.99	3.33	172.95	2.27	377.81	5.75
76.98	11.49	173.97	2.04	378.81	1.92
79.00	2.02	175.97	2.87	379.84	1.92
81.00	2.71	177.98	2.88	380.80	0.96
81.99	2.87	181.92	30.65		
91.99	2.26	182.93	9.59		
93.01	5.75	183.92	14.31		
94.00	3.83	184.94	5.75		
94.98	23.95	185.95	2.78		
108.00	2.87	193.93	4.03		
109.00	2.97	194.92	26.82		
112.96	2.87	195.92	5.75		
114.97	2.87	196.94	2.05		
118.98	4.74	197.91	4.79		
119.99	2.87	199.93	2.87		
121.00	5.75	209.92	2.87		
122.00	1.99	297.87	4.79		
122.96	6.74	327.87	3.47		
126.96	2.18	328.87	4.79		
132.98	3.83	329.88	15.34		
133.98	12.36	330.89	3.90		
134.99	4.37	331.82	13.56		
136.00	16.28	332.85	1.95		
136.99	2.41	333.80	4.89		
138.00	2.64	341.85	6.83		
142.94	11.74	342.86	3.70		
143.95	1.83	343.82	4.79		
144.96	2.93	344.81	2.87		
145.98	9.83	345.82	4.25		
146.98	3.83	346.83	1.92		
147.99	15.33	347.82	2.23		
148.98	7.66	357.85	3.83		
150.00	4.92	358.84	1.92		
150.98	2.87				

Spectrum No.36 (FAB+)

NCP309#14* x1 Bgd=1 7-NOV-91 14:34:02:03 70E FB+
 BpM=0 I=10v Hm=896 TIC=862456000 Acnt: Sys:FAB HMR: 65534000
 N. PARKINSON PT= 0° Cal: PFK14OCT MASS: 155

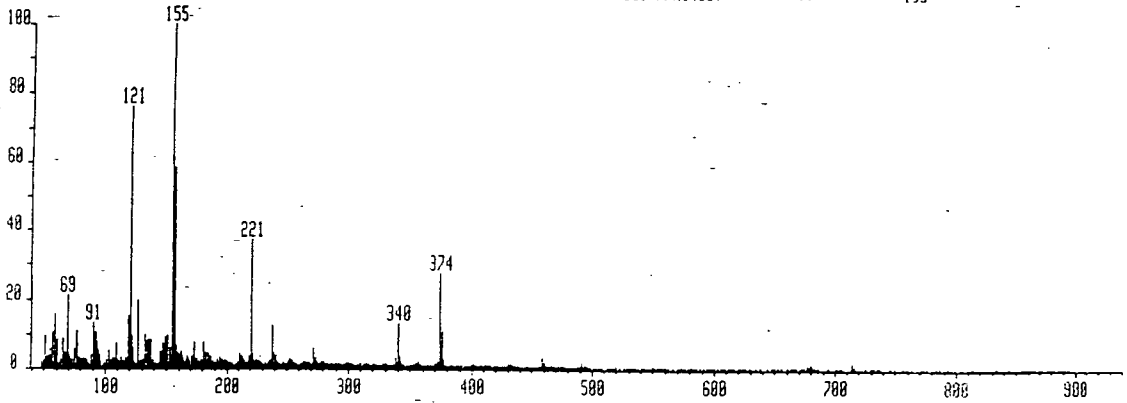

NCP309#16* x1 Bgd=18 7-NOV-91 14:34:02:18 70E FB-
 BpM=0 I=1.6v Hm=877 TIC=97384000 Acnt: Sys:FAB HMR: 10335000
 N. PARKINSON PT= 0° Cal: PFK14OCT MASS: 153

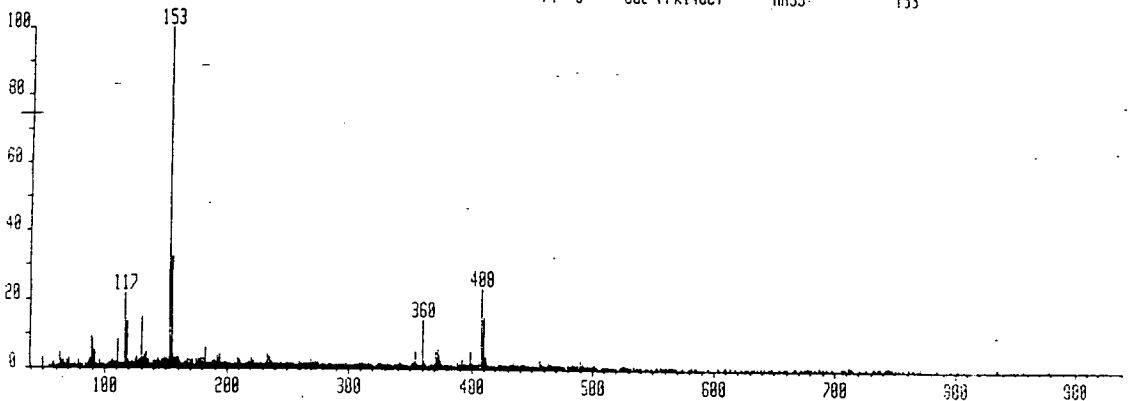

Mass	% Base	Mass	% Base	Mass	% Base	Mass	% Base
47.76	1.87	102.74	8.23	155.61	17.38	213.55	2.69
49.74	1.56	103.74	1.15	156.60	58.11	214.54	1.96
50.76	3.35	104.74	1.41	157.61	6.65	218.49	3.52
51.76	3.14	105.74	1.34	158.63	4.56	219.51	1.35
52.77	3.39	106.74	1.73	159.64	3.99	220.50	36.94
53.77	2.40	107.74	3.79	160.62	3.87	221.51	4.12
54.77	5.61	108.73	7.05	161.64	2.87	222.53	1.92
55.78	3.34	109.74	2.34	162.63	4.69	224.53	2.47
56.78	10.34	110.74	1.17	163.64	3.29	225.54	1.98
58.78	15.32	112.71	3.02	164.63	2.08	226.52	2.03
59.77	2.38	114.71	2.17	166.60	2.12	236.50	2.35
60.76	2.31	116.70	3.21	167.59	3.37	237.52	1.96
63.77	2.28	117.71	2.54	168.59	2.85	238.52	12.18
64.76	3.61	118.71	15.00	169.61	2.21	239.51	4.39
65.78	2.06	119.71	12.56	170.59	3.42	240.51	3.73
66.79	4.35	120.71	76.02	171.60	2.57	250.51	1.75
67.79	4.19	121.72	9.40	172.59	7.51	251.49	2.34
68.79	20.75	122.72	5.73	173.61	2.02	252.49	2.75
69.80	3.90	126.67	19.51	174.62	2.73	253.51	1.85
70.80	3.13	127.67	1.66	175.62	1.66	254.47	2.56
71.80	1.99	128.68	2.00	178.59	2.42	264.48	2.15
72.79	2.34	129.68	1.93	179.58	1.56	272.42	5.82
74.79	5.48	130.67	2.28	180.58	7.45	273.42	2.01
76.78	10.62	131.69	2.40	181.59	1.89	274.41	3.13
77.79	2.39	132.68	9.74	182.58	4.30	275.42	1.61
78.80	2.97	133.69	7.73	183.57	1.65	278.48	2.22
79.80	2.17	134.68	3.10	184.60	4.29	279.47	1.56
80.79	2.85	135.69	6.33	185.61	2.23	280.45	1.81
81.79	2.00	136.68	6.08	186.57	3.52	288.40	1.56
82.79	2.86	137.67	1.83	187.58	1.64	290.37	1.76
83.80	2.37	138.67	2.33	188.58	2.07	300.37	2.94
84.79	0.46	144.65	4.77	192.57	2.73	303.34	1.58
88.77	3.73	145.66	3.51	194.57	2.94	330.33	12.86
89.77	1.93	146.67	7.03	195.54	1.99	341.37	3.39
90.76	12.10	147.67	4.79	196.56	2.44	342.36	1.98
91.76	3.36	148.65	9.04	197.56	2.44	356.31	2.13
92.78	10.32	149.65	3.91	198.57	1.84	372.26	2.74
93.77	7.47	150.64	9.58	199.63	2.49	373.28	1.72
94.76	5.09	151.65	1.68	200.57	2.17	374.25	27.44
95.77	3.68	152.64	5.99	200.57	1.99	375.26	6.85
96.77	1.68	153.63	3.55	210.54	4.05	376.25	10.55
		154.61	100.00	211.55	2.61	377.26	2.58
				212.56	3.34	378.28	1.13

Spectrum No.37 (FAB+)

NCP343#10 x1 Bgd=6 5-MAY-92 10:20:0:01:35 70E FB-
 BpM=97 I=78uv Hw=966 TIC=8859000 Acnt: Sys:FAB HMR: 512000
 NIGEL PARKINSON PI= 0° Cal:PFK5MAY MASS: 97

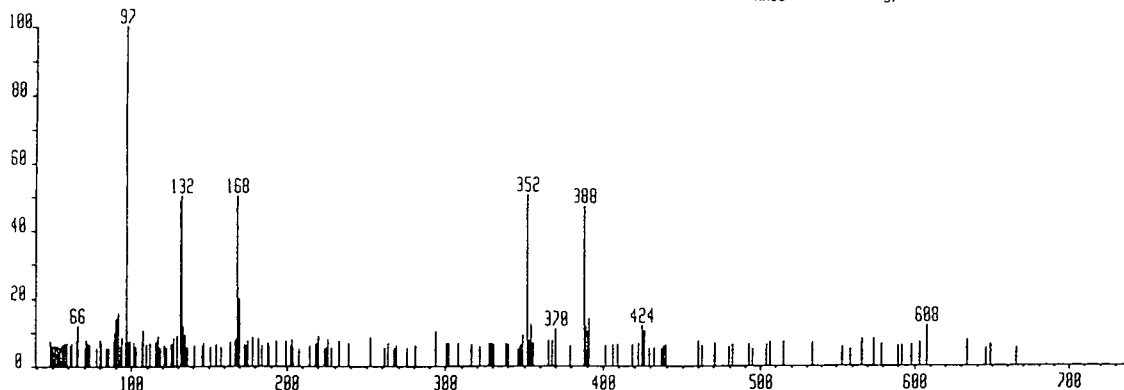

NCP343#15 x1 Bgd=5 5-MAY-92 10:20:0:02:11 70E FB-
 BpM=170 I=6.8uv Hw=1027 TIC=330004000 Acnt: Sys:FAB HMR: 39866000
 NIGEL PARKINSON PI= 0° Cal:PFK5MAY MASS: 170

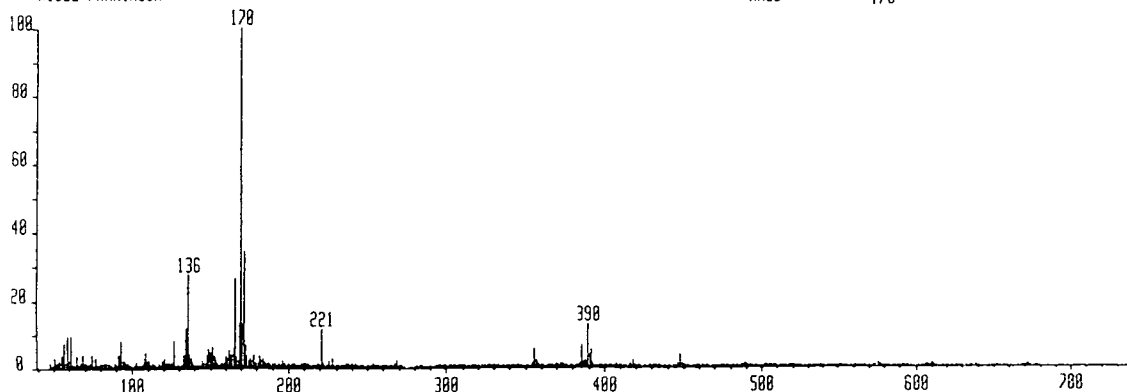

Mass	% Base	Mass	% Base	Mass	% Base	Mass	% Base
47.86	1.31	112.99	1.31	169.98	100.00	385.98	6.56
50.86	2.62	117.01	1.31	170.98	13.11	386.98	1.72
51.88	1.31	119.00	2.07	171.98	34.17	387.97	2.13
52.89	1.31	120.02	1.76	172.99	6.56	388.92	1.52
53.90	1.97	121.02	2.75	174.02	3.28	389.92	12.84
54.91	3.28	122.03	1.36	175.03	1.97	390.94	3.93
55.93	1.97	123.03	1.43	176.03	2.62	391.93	5.24
56.93	7.30	124.03	1.45	177.02	1.97	392.94	1.31
57.94	1.28	125.04	1.31	178.03	3.93	393.96	0.66
58.94	9.17	126.04	1.42	179.03	1.50		
59.95	2.06	126.99	7.86	180.03	1.37		
60.95	9.17	133.00	3.93	180.99	1.31		
64.96	3.39	134.01	11.80	181.99	3.28		
65.97	0.66	135.02	10.48	182.99	2.09		
66.98	1.31	136.03	27.35	184.00	2.62		
67.98	1.33	137.03	3.93	185.02	1.56		
68.97	3.93	138.04	2.64	186.01	1.41		
69.99	1.31	139.03	1.31	187.02	1.31		
71.00	1.31	145.00	1.97	188.01	1.31		
73.00	1.31	146.01	1.31	196.01	1.97		
75.01	3.93	147.02	1.46	197.02	0.67		
76.99	2.63	148.03	3.28	198.01	1.40		
80.02	1.19	149.02	5.43	200.00	1.31		
81.02	1.32	150.04	4.60	210.03	1.31		
82.02	1.31	151.01	3.93	211.00	1.31		
83.02	1.31	152.03	6.00	212.02	1.31		
84.03	1.31	153.00	3.28	218.98	1.31		
85.03	1.31	154.03	2.07	220.99	11.17		
89.01	1.31	155.00	1.47	222.00	1.41		
91.01	3.93	157.00	1.31	226.03	1.97		
92.01	1.31	158.01	1.31	228.05	2.62		
93.03	7.90	159.02	1.51	269.04	1.97		
94.02	2.20	160.02	3.44	354.00	1.31		
95.01	1.97	161.02	2.62	354.99	1.31		
96.03	1.54	162.04	5.24	356.00	5.35		
97.03	1.31	163.03	2.75	357.01	1.90		
103.01	1.59	164.03	3.93	358.03	1.31		
107.01	1.38	165.03	5.93	370.02	1.31		
108.02	2.63	166.03	26.22	371.99	1.31		
109.02	4.61	167.03	3.02	374.01	1.31		
110.02	1.97	168.04	1.97	384.99	1.31		
111.04	2.21	168.98	13.11				

Spectrum No.38 (FAB+)

NCPFP#9* x1 8gd=6 5-MAY-92 11:56:08:01:28 78E FB-
 BpM=0 I=78uv Hm=877 TIC=4844000 Acnt: Sys:FAB HMR: 512000
 NIGEL PARKINSON PT= 0° Cal:PFKSMAY MASS: 153

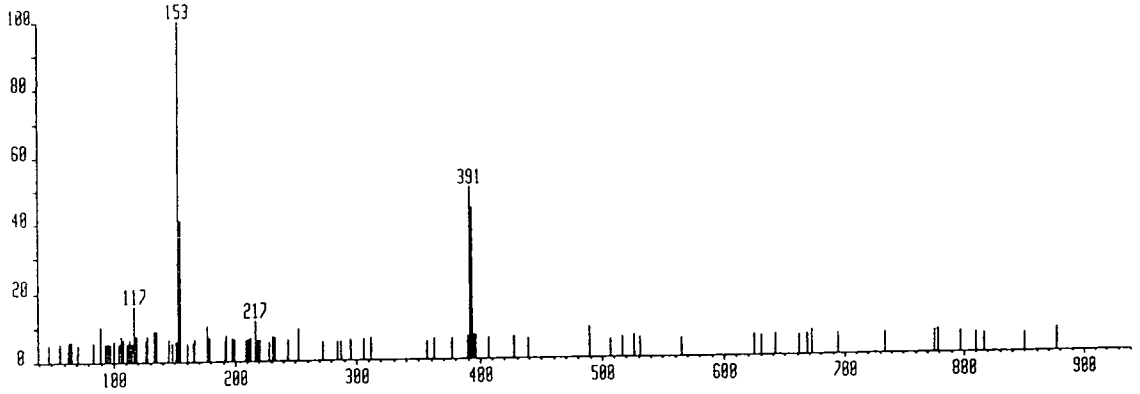

NCPFP#11* x1 8gd=1 5-MAY-92 11:56:08:01:42 78E FB+
 BpM=0 I=5.8v Hm=895 TIC=239283000 Acnt: Sys:FAB HMR: 37896000
 NIGEL PT= 0° Cal:PFKSMAY MASS: 155

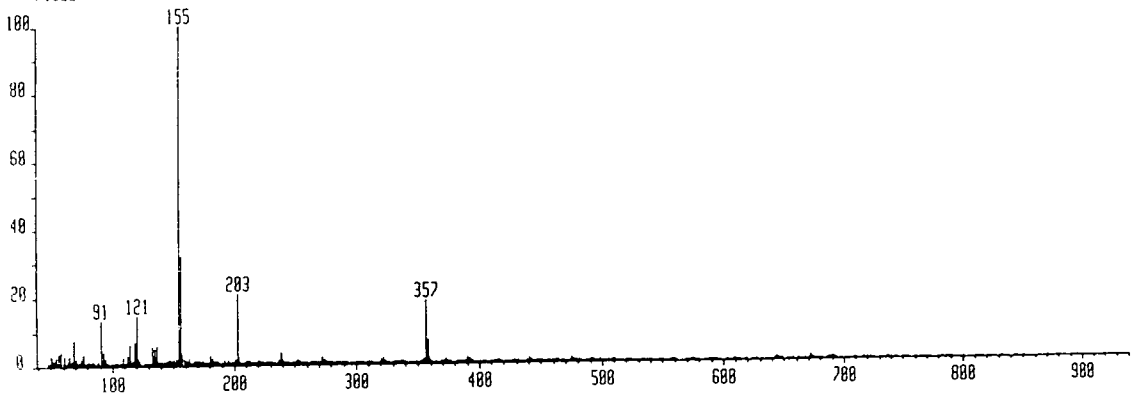

Mass	% Base	Mass	% Base	Mass	% Base
50.88	2.70	140.94	1.35	252.91	1.35
51.89	1.35	142.93	1.35	272.84	2.07
52.90	1.35	143.94	0.68	273.85	0.74
53.91	1.35	144.94	1.36	274.85	1.35
54.91	2.26	145.95	1.35	320.83	1.35
56.92	3.38	146.96	2.05	354.78	1.41
58.92	4.05	147.96	1.35	355.76	0.68
60.93	2.82	148.94	1.51	356.78	18.24
63.93	1.47	149.95	1.35	357.78	4.73
64.94	2.70	150.96	2.20	358.77	6.93
66.96	1.35	152.94	2.01	359.78	1.64
67.96	1.35	153.91	1.49	360.80	0.68
68.95	7.52	154.91	100.00		
69.97	1.35	155.91	10.13		
70.97	2.03	156.90	31.87		
74.98	2.05	157.91	3.38		
76.96	3.51	158.94	1.98		
84.99	1.35	159.95	1.35		
90.98	12.92	160.94	1.35		
91.98	1.54	162.94	2.03		
92.99	4.05	166.91	1.35		
93.98	2.03	167.91	1.45		
94.96	2.06	168.91	1.39		
108.96	2.24	169.91	1.35		
112.95	3.01	170.92	1.35		
114.96	6.06	172.93	1.36		
116.95	1.35	174.93	1.35		
117.96	1.35	174.93	1.35		
118.95	6.76	180.90	2.80		
119.96	4.92	184.92	1.39		
120.97	14.35	192.91	1.35		
121.97	2.03	194.91	1.35		
122.97	1.35	200.90	1.58		
132.93	5.40	201.91	1.35		
133.96	2.03	202.91	20.46		
134.95	4.73	203.91	2.03		
135.96	2.11	210.92	1.35		
136.95	5.67	212.94	1.35		
138.94	1.35	212.94	1.35		
		220.89	1.35		
		238.89	3.38		
		239.90	1.35		

Spectrum No.39(FAB+)

rds0200001 Scan 8 RT=0:44 100%=134539 mv 7 Jul 93 15:00
LRP +FAB NCP 79 718706 POS-FAB-MS GLY

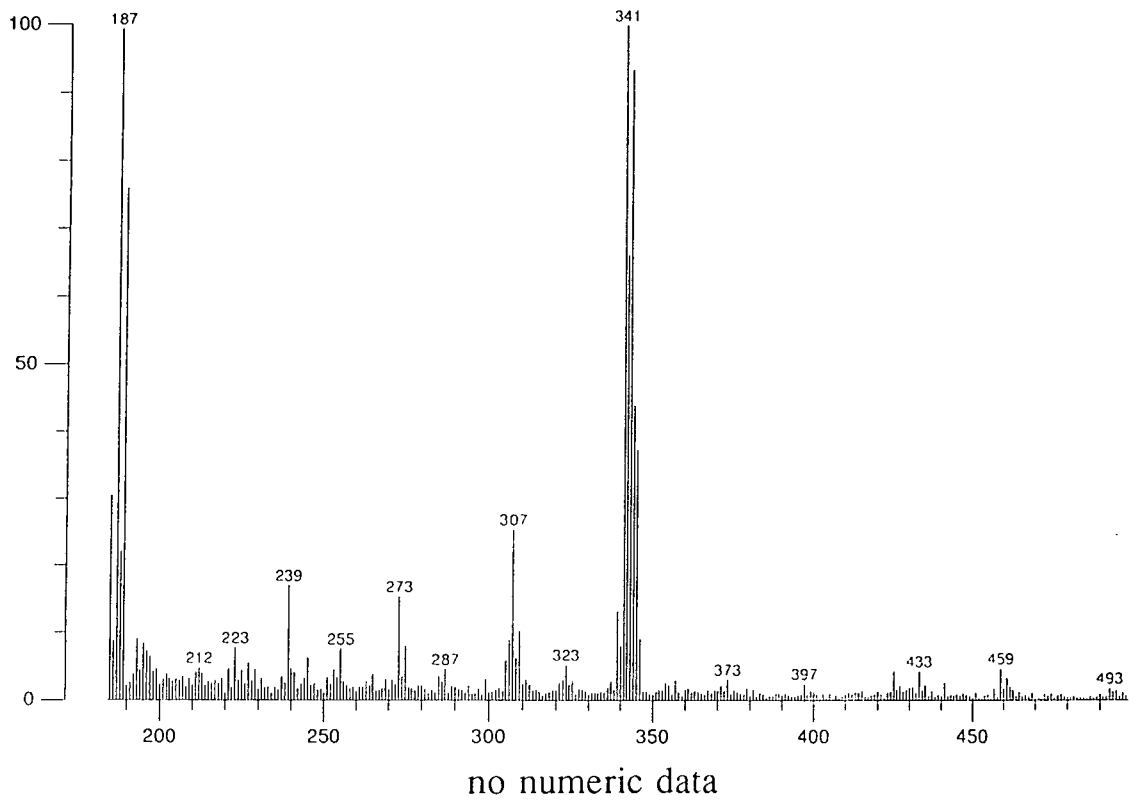

Spectrum No.40 (FAB-)

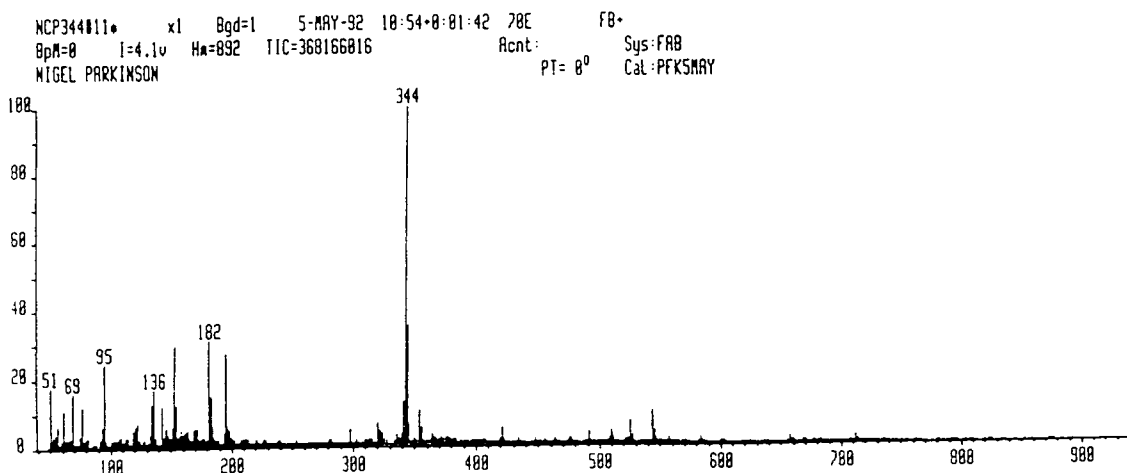
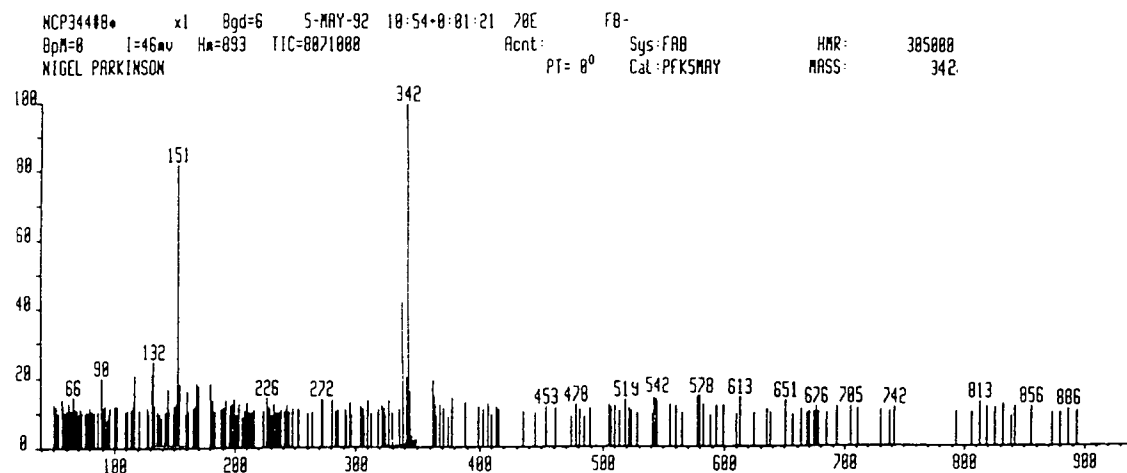

Mass	% Base
65.97	17.56
89.99	20.12
112.98	21.00
130.97	20.97
131.97	24.89
144.99	15.50
150.98	81.98
152.00	18.78
159.99	16.34
168.99	19.79
169.99	18.94
179.98	19.71
339.00	39.98
341.01	19.11
342.01	100.00

Spectrum No.41 (FAB+)

NCP34 x1 0gd=5 S-MAY-92 10:20-0-02:11 78E EG-
 SpM=170 I=6.0v Ha=1027 TIC=330004000 Acnt: Sys: FAB HR: 2573000
 NIGEL PARKINSON PT= 0⁰ Cal: PFKSMAY MASS: 150

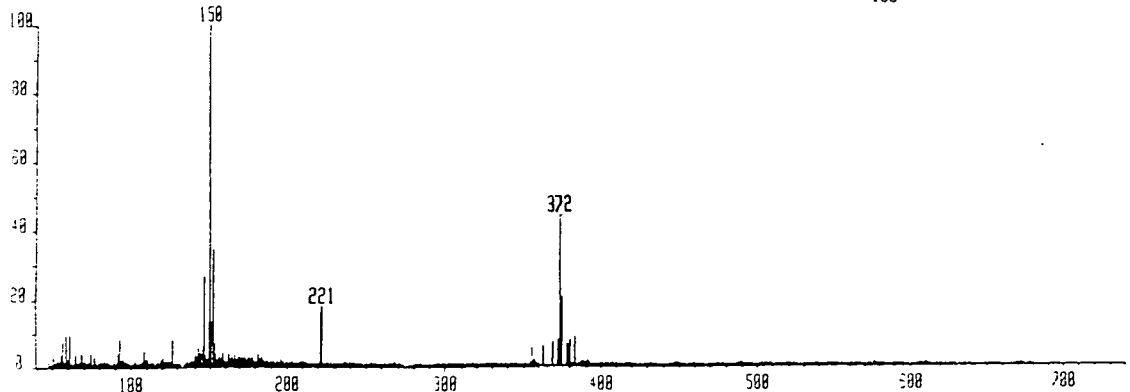

Mass	% Base	Mass	% Base
47.86	1.31	154.03	3.28
50.86	2.62	155.00	1.97
51.88	1.31	157.00	2.62
52.89	1.31	158.01	1.97
53.90	1.97	159.02	3.93
54.91	3.28	160.02	1.50
55.93	1.97	161.02	1.37
56.93	7.30	162.04	1.31
57.94	1.28	163.03	3.28
58.94	9.17	164.03	2.09
59.95	2.06	165.03	2.62
60.95	9.17	166.03	1.56
64.96	3.39	167.03	1.41
65.97	0.66	168.04	1.31
66.98	1.31	168.98	3.93
67.98	1.33	169.98	2.64
68.97	3.93	170.98	1.31
69.99	1.31	171.98	1.97
71.00	1.31	172.99	1.31
73.00	1.31	174.02	1.46
75.01	3.93	175.03	3.28
76.99	2.63	176.03	2.62
80.02	1.19	177.02	1.97
81.02	1.32	178.03	3.93
82.02	1.31	179.03	1.50
83.02	1.31	180.03	1.37
84.03	1.31	180.99	1.31
85.03	1.31	181.99	3.28
89.01	1.31	182.99	2.09
91.01	3.93	184.00	2.62
92.01	1.31	185.02	1.56
93.03	7.90	186.01	1.41
94.02	2.20	187.02	1.31
95.01	1.97	188.01	1.31
96.03	1.54	196.01	1.97
97.03	1.31	197.02	0.67
103.01	1.59	198.01	1.40
107.01	1.38	200.00	1.31
108.02	2.63	210.03	1.31
109.02	4.61	211.00	1.31
110.02	1.97	212.02	1.31
111.04	2.21	218.98	1.31
119.00	2.07	220.99	11.17
120.02	1.76	222.00	1.41
121.02	2.75	226.03	1.97
122.03	7.86	228.05	2.62
123.03	3.93	269.04	1.97
124.03	3.28	354.00	1.31
125.04	2.07	354.99	1.31
126.04	1.47	356.00	5.35
126.99	1.31	357.01	1.90
133.00	1.31	358.03	11.80
134.01	1.51	370.02	10.48
135.02	3.44	371.99	54.91
136.03	2.62	373.01	27.35
137.03	5.24	379.03	9.17
138.04	2.75	380.02	10.48
139.03	3.93	384.99	13.11
145.00	5.93		
146.01	26.22		
147.02	3.02		
148.03	1.97		
149.02	13.11		
150.04	100.00		
151.01	13.11		
152.03	34.17		
153.00	6.56		

Spectrum No.42(FAB+)

rds0220003 Scan 7 RT=0.39 100%=167789 mv 7 Jul 93 15:28
LRP +FAB NCP 83 718710 POS-FAB-MS GLY

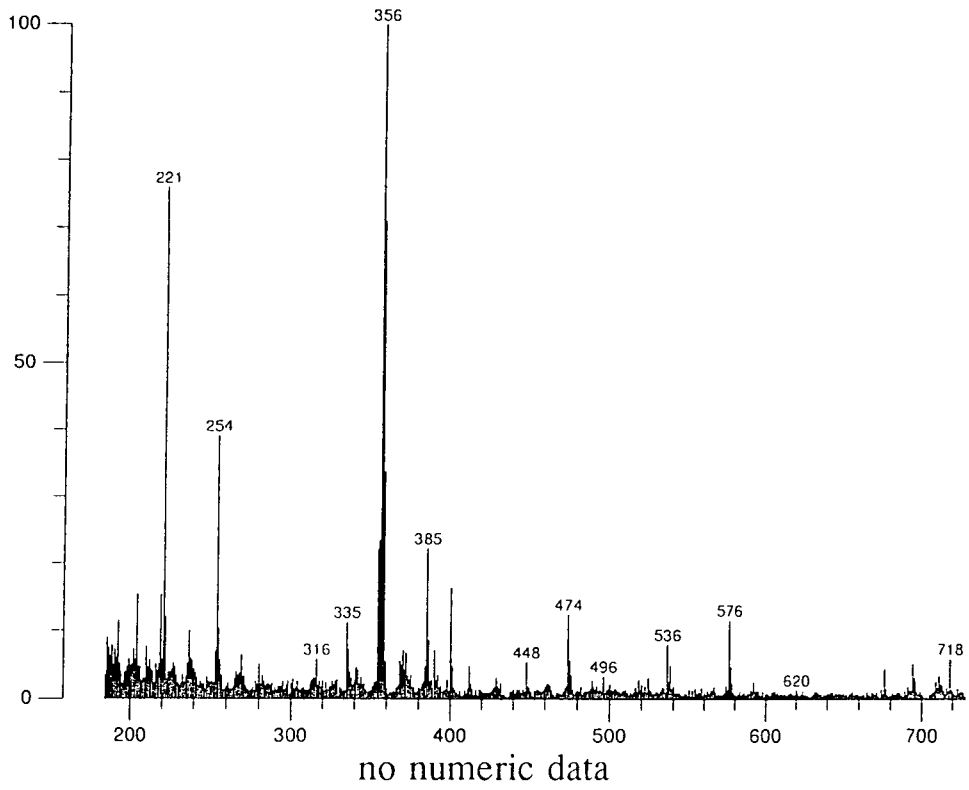

Spectrum No.43(FAB+)

NCP411A#12* x1 Bgd=5 5-MAY-92 10:36:00:01:49 78E FB+
 BpM=0 I=10v Hn=891 TIC=415006016 Acnt: Sys:FAB HMR: 4352000
 NIGEL PARKINSON PT= 0° Cal:PFKSMAY MASS: 243
 *x1.0

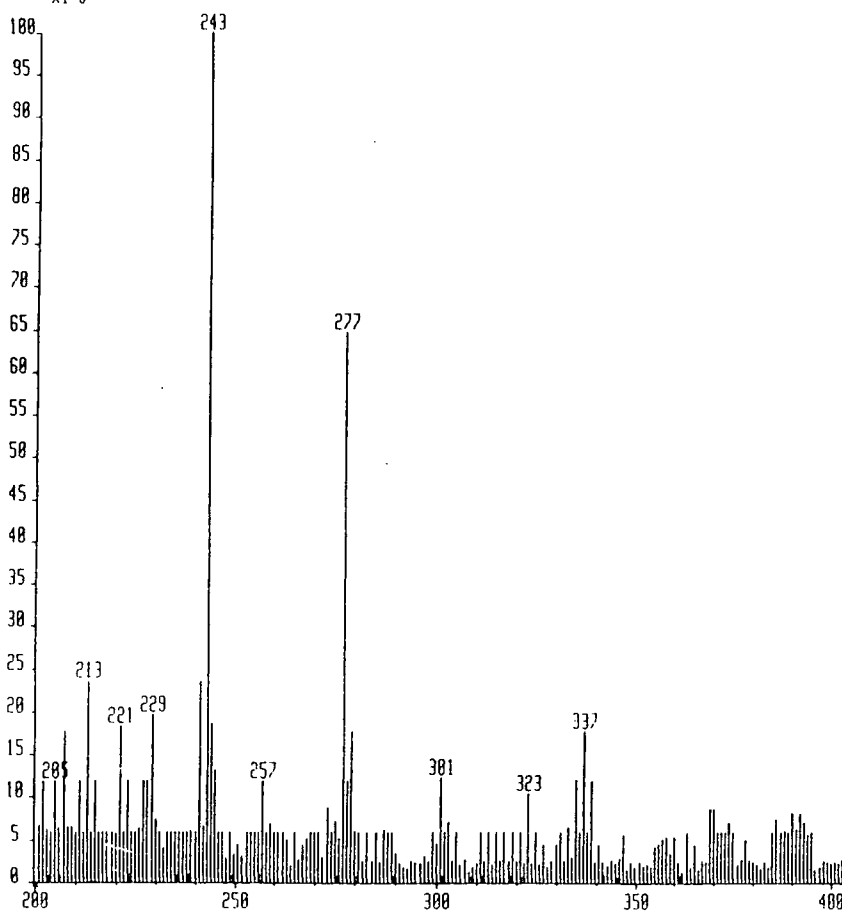

Mass	% Base	Mass	% Base
54.90	1.98	134.99	1.56
55.90	3.13	135.99	3.13
56.92	29.30	136.98	8.16
57.93	2.34	137.99	1.94
58.93	1.21	148.98	4.17
59.92	1.66	149.98	2.34
60.49	0.39	150.98	51.56
60.92	6.64	151.99	7.78
68.96	1.60	152.99	2.74
69.98	0.78	164.99	3.13
70.98	1.17	165.99	2.03
71.98	1.17	166.99	1.56
72.97	2.79	169.94	1.66
73.98	5.08	180.97	1.17
74.99	39.47	185.01	64.01
75.99	1.56	186.01	4.69
83.01	1.12	186.96	1.57
89.99	1.56	206.99	1.17
90.99	1.17	212.99	1.56
93.00	100.00	220.94	1.22
94.00	5.40	228.98	1.30
95.00	1.87	240.99	1.56
103.00	1.30	242.99	6.64
104.20	46.26	243.99	1.23
108.99	1.17	277.01	4.30
110.00	3.91	279.01	1.17
111.00	1.25	336.90	1.17
114.98	1.37		
116.99	1.71		
118.99	1.17		
119.98	1.15		
120.99	1.56		
122.99	1.56		
130.98	1.24		

Spectrum No.44 (FAB+)

NCP420130* x1 Bgd=6 5-MAY-92 12:27:0:03:59 70E F0-
 BpM=0 I=156mv Hw=800 TIC=8832000 Acnt: Sys:FAB HMR: 1024000
 NIGEL PARKINSON PT= 0° Cal:PFKSMAY MASS: 183

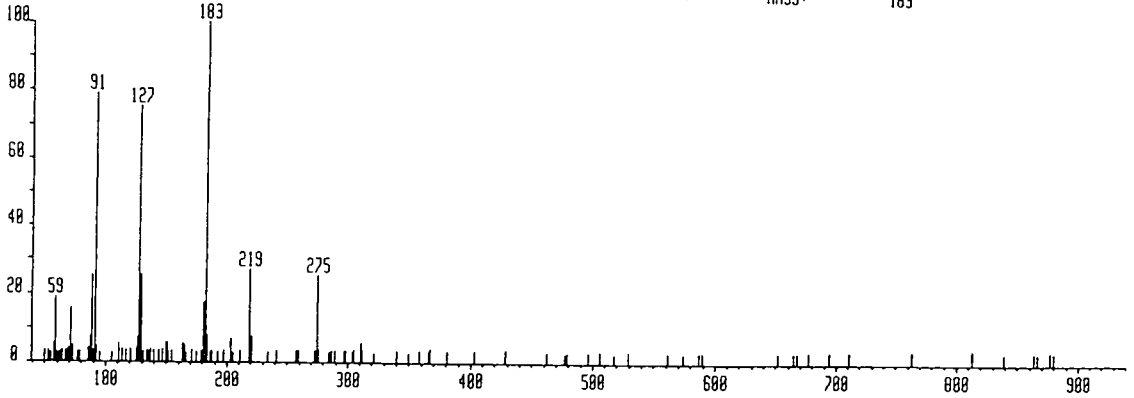

NCP420131* x1 Bgd=25 5-MAY-92 12:27:0:04:06 70E F0-
 BpM=0 I=1.0v Hw=895 TIC=37173000 Acnt: Sys:FAB HMR: 6556000
 NIGEL PARKINSON PT= 0° Cal:PFKSMAY MASS: 93

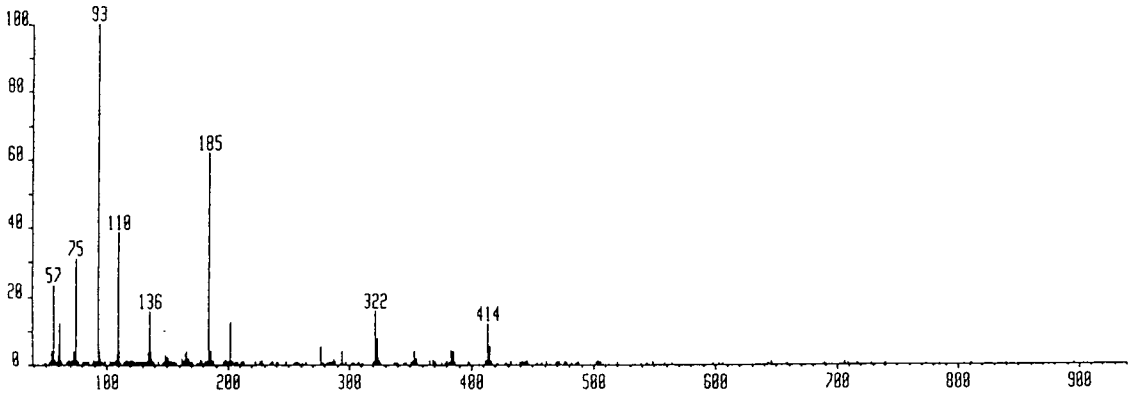

Mass	% Base	Mass	% Base
54.90	3.85	182.98	1.14
55.90	3.85	184.96	61.54
56.92	23.08	185.97	3.94
57.93	1.23	186.91	3.85
58.93	0.83	197.96	1.23
59.92	2.72	201.98	12.35
60.93	12.00	203.01	1.14
61.93	1.08	227.96	1.13
68.94	1.41	276.94	5.02
72.97	3.85	287.89	1.49
73.98	3.85	293.96	3.85
74.98	30.77	321.84	15.43
75.99	1.13	322.85	4.39
89.98	1.25	323.84	7.69
90.99	0.96	324.84	1.58
92.99	100.00	325.91	0.81
94.00	4.01	353.85	3.86
94.99	1.55	354.85	0.95
102.97	1.16	355.86	1.64
108.98	2.64	365.81	0.96
110.00	38.48	368.94	1.52
111.00	3.85	383.83	4.18
116.98	1.38	384.85	1.38
117.99	0.57	385.88	3.85
118.97	1.08	411.83	1.14
120.98	1.52	412.82	0.60
122.00	0.53	413.82	11.54
122.97	1.17	414.85	3.85
134.97	3.50	415.83	5.17
135.97	15.38	416.82	0.83
136.98	3.85		
137.65	0.54		
137.99	1.23		
148.97	2.90		
149.97	1.29		
150.96	1.91		
161.97	1.58		
164.96	2.91		
165.98	3.85		
166.96	1.07		
167.98	1.59		
177.96	1.23		

Spectrum No.45(FAB+)

NCPL10#11* x1 8gd=3 30-SEP-92 14:51:08:02:07 70E FB+
 BpM=0 I=965uv Hw=3593 TIC=107002000 Acnt: Sys:FABHI
 NIGEL PARKINSON PT= 0° Cal: PFK23SEPS
 *x1.0

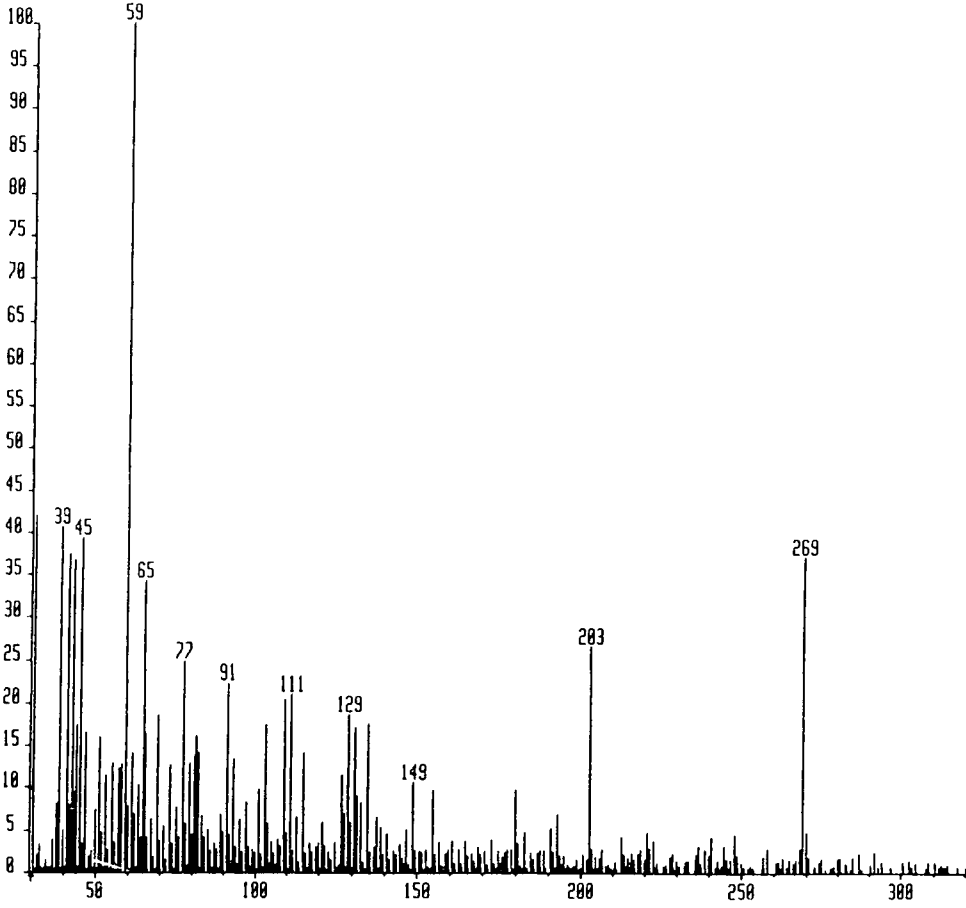

Mass	% Base	Mass	% Base	Mass	% Base	Mass	% Base
40.99	37.35	74.94	7.57	116.88	3.29	212.76	4.14
41.97	7.89	75.93	4.08	117.92	2.37	220.79	4.63
42.97	36.57	76.94	24.67	118.87	2.86	222.87	3.59
43.01	9.39	77.95	5.69	119.87	3.41	236.71	3.07
43.98	17.31	78.95	12.80	120.90	5.82	240.75	4.13
44.98	39.21	79.95	4.38	121.86	3.05	244.75	3.07
45.99	3.30	80.88	13.69	124.87	3.49	247.79	4.44
46.96	16.50	80.97	16.11	126.88	11.43	257.75	2.75
47.92	1.90	81.90	14.04	127.90	6.86	267.73	2.72
48.95	2.42	82.90	6.64	128.89	18.54	268.75	37.09
49.96	7.24	83.92	4.08	129.89	5.88	269.77	4.62
50.97	15.92	84.93	4.95	130.89	17.05	286.73	2.17
51.98	4.68	85.93	2.53	131.83	8.85	291.58	2.35
52.98	11.44	86.92	3.43	132.86	8.20	323.64	1.55
53.99	2.58	87.95	2.62	134.89	17.54	324.73	1.45
54.98	12.90	88.93	6.70	135.89	2.40	336.68	1.55
55.99	3.46	89.91	4.65	136.87	2.92	349.66	1.82
56.99	12.25	90.93	22.25	137.88	6.43	350.77	0.73
57.98	12.75	91.92	4.39	138.87	5.22	356.68	1.90
58.98	100.00	92.91	13.29	139.81	2.01		
59.96	7.73	93.91	2.96	140.87	4.55		
60.96	14.02	94.91	6.16	144.86	3.21		
61.06	1.33	95.91	2.28	146.87	4.90		
61.95	6.81	96.91	9.12	148.84	10.46		
62.96	10.16	100.88	9.70	154.85	9.61		
63.95	4.05	102.93	17.40	156.84	3.48		
64.91	34.22	103.92	5.74	160.84	3.67		
64.97	16.34	104.92	3.54	164.87	3.59		
65.97	4.06	106.91	3.78	172.80	3.81		
66.96	6.32	107.92	3.03	179.89	9.70		
68.94	18.59	108.91	20.33	180.81	3.38		
69.94	3.67	109.91	4.54	190.78	5.07		
70.95	5.42	110.90	20.94	192.78	6.78		
71.93	1.42	111.92	2.45	202.79	26.39		
72.96	12.52	112.90	6.45	203.81	2.69		
73.93	3.29	114.89	14.04				

Appendix Four

The Board of Studies in Chemistry requires that each postgraduate research thesis contains an appendix listing:-

- (i) all research colloquia, seminars and lectures arranged by the Department of Chemistry during the period of the author's residence as a postgraduate student;
- (ii) lectures organised by Durham University Chemical Society;
- (iii) all research conferences attended and papers presented by the author during the period when research for the thesis was carried out;
- (iv) details of the postgraduate induction course.

Colloquia, Lectures and Seminars Given by Invited Speakers October 1989 - September 1992

(Those attended are marked *)

- | | |
|----------|--|
| 10.10.89 | Prof. J.I.G Cadogan (B.P.)
<i>From Pure Science to Profit</i> |
| 17.10.89 | Dr. F. Palmer (Nottingham University) |
| * | <i>Thunder and Lightning</i> |
| 25.10.89 | Prof. C. Floriani (Lausanne University, Switzerland)
<i>Molecular Aggregates - A Bridge Between Homogeneous and Heterogenous Systems</i> |
| 01.11.89 | Dr. J.P.S. Badyal (Durham University)
<i>Breakthroughs in Heterogeneous Catalysis</i> |
| 09.11.89 | Prof. N.N. Greenwood (Leeds University)
<i>Novel Cluster Geometries in Metalloborane Chemistry</i> |
| 10.11.89 | Prof. J.E. Bercaw (California Institute of Technology)
<i>Synthetic and Mechanistic Approaches to Ziegler-Natta Polymerisation of Olefins</i> |
| 13.11.89 | Dr. J. Becher (Odense University) |
| * | <i>Synthesis of New Macrocyclic Systems using Heterocyclic Building Blocks</i> |
| 16.11.89 | Dr. D. Parker (Durham University) |
| * | <i>Macrocycles, Drugs and Rock 'n' Roll</i> |

- 29.11.89 Prof. D.J. Cole-Hamilton (St. Andrews University)
New Polymers from Homogeneous Catalysis
- 30.11.89 Dr. M.N. Hughes (King's College, London)
* *A Bug's Eye View of the Periodic Table*
- 04.12.89 Dr. D. Graham (B.P. Research Centre)
How Proteins Absorb on Interfaces
- 06.12.89 Dr. R.L. Powel (ICI)
* *The Development of CFC Replacements*
- 07.12.89 Dr. A. Butler (St. Andrews University)
* *The Discovery of Penicillin: Facts and Fancies*
- 13.12.89 Dr. J. Klinowski (Cambridge University)
Solid State NMR Studies of Zeolite Cages
- 15.12.89 Prof. R. Huisgen (Universität München)
* *Recent Mechanistic Studies of [2+2] Additions*
- 24.01.90 Dr. R.N. Perutz (York University)
Plotting the Course of C-H Activations with Organometallics
- 31.01.90 Dr. U. Dyer (Glaxo)
* *Synthesis and Conformation of C-Glycosides*
- 01.02.90 Prof. J.H. Holloway (Leicester University)
* *Noble Gas Chemistry*
- 07.02.90 Dr. D.P. Thompson (Newcastle University)
The Rôle of Nitrogen in Extending Silicate Crystal Chemistry
- 08.02.90 Rev. R. Lancaster (Kimbolton Fireworks)
* *Fireworks - Principles and Practice*
- 12.02.90 Prof. L. Lunazzi (University of Bologna)
Application of Dynamic NMR to the Study of Conformational Isomerism
- 14.02.90 Prof. D. Sutton (Simon Fraser University, Vancouver B.C.)
Synthesis and Applications of Dinitrogen and Diazo Compounds of Rhenium and Iridium
- 15.02.90 Prof. L. Crombie (Nottingham University)
The Chemistry of Cannabis and Khat
- 21.02.90 Dr. C. Bleasdale (Newcastle University)
* *The Mode of Action of some Anti-tumour Agents*
- 22.02.90 Prof. D.T. Clark (ICI Wilton)
Spatially Resolved Chemistry usin Nature's Paradigm in the Advanced Materials area
- 28.02.90 Dr. R.K. Thomas (Oxford University)
Neutron Reflectometry from Surfaces
- 01.03.90 Dr. J.F. Stoddart (Sheffield University)
* *Molecular Lego*

- 08.03.90 Dr. A.K. Cheetham (Oxford University)
Chemistry of Zeolite Cages
- 21.03.90 Dr. I. Powis (Nottingham University)
Spinning Off in a Huff: Photodissociation of Methyl Iodide
- 23.03.90 Prof. J.M. Bowman (Emory University)
Fitting Experiment with theory Ar-OH
- 29.05.90 Prof. N. Bartlett (University of California)
* *Silver Trifluoride*
- 09.07.90 Prof L.S. German (USSR Academy of Sciences - Moscow)
* *New Syntheses in Fluoroaliphatic Chemistry: Recent Advances in the Chemistry of Fluorinated Oxiranes*
- 09.07.90 Prof V.E. Platonov (USSR Academy of Sciences - Novosibirsk)
* *Polyfluoroindanes: Synthesis and Transformation*
- 09.07.90 Prof I.N. Rozhkov (USSR Academy of Sciences - Moscow)
* *Reactivity of Perfluoroalkyl Bromides*
- 11.10.90 Dr. W.A. MacDonald (ICI Wilton)
* *Materials for the Space Age*
- 24.10.90 Dr. M. Bochmann (U.E.A.)
Synthesis, Reactions and Catalytic Activity of Cationic Titanium Alkyls
- 26.10.90 Prof. R. Soulen (South Western University, Texas)
* *Chemistry of some Fluorinated Cyclobutenes*
- 31.10.90 Dr. R. Jackson (Newcastle University)
* *New Synthetic Methods: α -Aminoacids and Small Rings*
- 01.11.90 Dr. N. Logan (Nottingham University)
Rocket Propellants
- 06.11.90 Dr. P. Kocovsky (Uppsala University)
* *Stereo-controlled Reactions Mediated by Transition and Non-Transition Metals*
- 07.11.90 Dr. D. Gerrard (B.P.)
Raman Spectroscopy for Industrial Analysis
- 07.11.90 Dr. W. Dolbier (Gainesville, Florida)
* *Rearrangements of bis CF₃ Vinyl Aromatics: a route to 1,3,5-Hexatrienes*
- 08.11.90 Dr. S. K. Scott (Leeds University)
Clocks, Oscillations and Chaos
- 14.11.90 Prof. T. Bell (SUNY, Stony Brook, U.S.A.)
* *Functional Molecular Architecture and Molecular Recognition*
- 21.11.90 Prof. J. Pritchard (Queen Mary and Westfield College, London)
Copper Surfaces and Catalysis
- 28.11.90 Dr. B.J. Whitaker (Leeds University)

*Two-dimensional Velocity Imaging of State-Selected Reaction**Products*

- 29.11.90 Prof D. Crout (Warwick University)
* *Enzymes in Organic Chemistry*
- 05.12.90 Dr. P.G. Pringle (Bristol University)
Metal Complexes with Functionalised Phosphines
- 13.12.90 Prof. A.H. Cowley (University of Texas)
New Organometallic Routes to Electronic Materials
- 15.01.91 Dr. B.J. Alder (Lawrence Livermore Labs., California)
Hydrogen in all its Glory
- 17.01.91 Dr. P. Sarre (Nottingham University)
Comet Chemistry
- 23.01.91 Prof. J.S. Higgins (imperial College, London)
Rheology and Molecular Structure of Ionomer Solutions
- 24.01.91 Dr. P.J. Sadler (Birbeck College, London)
Design of Inorganic Drugs: Precious Metals, Hypertension and HIV
- 30.01.91 Prof. E. Sinn (Hull University)
Coupling of Little Electrons in Big Molecules. Implications for the active Site of Macromolecules
- 31.01.91 Dr. D. Lacey (Hull University)
Liquid Crystals
- 06.02.91 Dr. R. Bushby (Leeds University)
Biradicals and Organic Magnets
- 14.02.91 Dr. M.C. Petty (Durham University)
Molecular Electronics
- 20.02.91 Prof. B.L. Shaw (Leeds University)
Synthesis with Coordinated, Unsaturated Phosphine Ligands
- 28.02.91 Dr. J. Brown (Oxford University)
* *Can Chemistry Provide Catalysts Superior to Enzymes?*
- 06.03.91 Dr. C.M. Dobson (Oxford University)
NMR Studies of Dynamics in Molecular Crystals
- 07.03.91 Dr. J. Markam (ICI Pharmaceuticals)
DNA Fingerprinting
- 16.04.91 Dr. J. Murphy (Nottingham University)
* *The Rôle of Radicals in the Construction and Destruction of Heterocycles*
- 24.04.91 Prof. R.R. Schrock (MIT)
Metal-Ligand Multiple Bonds and Metathesis Initiators
- 25.04.91 Prof. T. Hudlicky (Virginia Polytechnic Institute)
Biocatalysis and Symmetry Based Approaches to the Efficient Synthesis

of Complex Natural Products

- 20.06.91 Prof. M.S. Brookhart (University of North Carolina)
*Olefin Polymerisations, Oligomerisations and Dimerisations Using
Electrophilic Late Transition Metal Catalysts*
- 29.07.91 Dr. M.A. Brimble (Massey University, New Zealand)
Synthetic Studies Towards the Antibiotic Griseusin-A
- 17.10.91 Dr. J.A. Salthouse (Manchester University)
* *Son et Lumiere*
- 31.10.91 Dr. R. Keeley (Metropolitan Police)
Modern Forensic Science
- 06.11.91 Dr. B.F.G. Johnson (Edinburgh University)
Cluster-Surface Analogies
- 07.11.91 Dr. A.R. Butler (St. Andrews University)
* *Traditional Chinese Herbal Drugs*
- 13.11.91 Prof. D. Gani (St. Andrews University)
* *The Chemistry of PLP Dependant Enzymes*
- 20.11.91 Dr. R. More O'Ferrall (University College, Dublin)
* *Some Acid-Catalysed Rearrangements in Organic Chemistry*
- 28.11.91 Prof. I.M. Ward (Leeds University)
The Science & Technology of Orientated Polymers
- 04.12.91 Prof. R. Grigg (Leeds University)
* *Palladium Catalysed Cyclisation and Ion Capture Processes*
- 05.12.91 Prof. A.L. Smith (ex Unilever)
Soap Detergents and Black Puddings
- 11.12.91 Dr. W.D. Cooper (Shell Research)
Colloid Science, Theory, and Practice
- 09.01.92 Mr. C.E. Snyder (U.S. Air Force, Ohio)
* *Perfluoropolyethers*
- 16.01.92 Dr. N.J. Long (Exeter University)
* *Metallocenophanes-Chemical Sugar-tongs*
- 22.01.92 Dr. K.D.M. Harris (St Andrews University)
Understanding the Properties of Solid Inclusion Compounds
- 29.01.92 Dr. A. Holmes (Cambridge University)
* *Cycloaddition Reactions in the Service of the Synthesis of Piperidine
and Indolizidine Natural Products*
- 30.01.92 Dr. M. Anderson (Shell Research, Sittingbourne)
* *Recent Advances in the Safe and Selective Chemical Control of Insect
Pests*

- 12.02.92 Dr. D.E. Fenton (Sheffield University)
polynuclear Complexes of Molecular Clefts as Models for Copper Biosites
- 13.02.92 Dr. J. Saunders (Glaxo Research)
* *Molecular Modelling in Drug Discovery*
- 19.02.92 Prof. E.J. Thomas (Manchester University)
* *Application of Organo-Stannanes to Organic Synthesis*
- 20.02.92 Prof. E. Vogel (University of Cologne)
Porphyrins: Molecules of Interdisciplinary Interest
- 25.02.92 Prof. J.F. Nixon (University of Sussex)
Phosphaalkynes, New Building Blocks in Inorganic and Organometallic Chemistry
- 26.02.92 Prof. M.L. Hitchman (Strathclyde University)
Chemical Vapour Deposition
- 05.03.92 Dr. N.C. Billingham (University of Sussex)
Degradable Plastics-Myth or Magic?
- 10.03.92 Dr. H.C. Fielding (ICI, Chemicals & Polymers)
* *Fluoropolymer Membranes*
- 11.03.92 Dr. S.E. Thomas (Imperial College, London)
Recent Advances in Organoiron Chemistry
- 12.03.92 Dr. R.A. Hann (ICI Imagedata)
Electronic Photography- An Image of the Future
- 18.03.92 Dr. H. Maskill (Newcastle University)
Mechanistic Studies of Organic Group Transfer Reactions
- 07.04.92 Prof. D.M. Knight (Durham University)
Interpreting Experiments: The Beginning of Electrochemistry
- 30.04.92 Dr. A. Marhold (Bayer Co., Leverkusen)
* *Fluorine Chemistry in the Bayer Company*
- 13.05.92 Dr. J-C. Gehert (Ciba Geigy, Basel)
Some Aspects of Industrial Agrochemical Research

Research Conferences Attended

- 15.12.89 Royal Society of Chemistry Perkin Division, One Day Meeting,
Durham University.
- 07.03.90 SCI Graduate Symposium, York University.
- 02.04.90 North East Graduate Symposium, Newcastle University.
- 19.12.90 'Modern Aspects of Stereochemistry', One Day Meeting, Sheffield
University
- Sept 91 13th International Symposium on Fluorine Chemistry, Ruhr Universität,
Bochum, Germany.
- 05.09.92 Royal Society of Chemistry Perkin Division, Durham University.

First Year Induction Course

This course consists of a series of one hour lectures on the services available in the department, as well as an examined six week taught course on modern nmr techniques.

Safety Matters - Dr. M.R. Compton

Electrical Appliances - Mr. B.T. Barker

Chromatography and Microanalysis - Mr. T.F. Holmes

Atomic Absorptiometry and Inorganic Analysis - Mr. R. Coult

Library Facilities - Ms M. Bird

Mass Spectroscopy - Dr. M Jones

Nuclear Magnetic Resonance Spectroscopy - Dr. R.S. Matthews

Glass-blowing Techniques - Mr. R. Hart and Mr. G. Haswell

Modern Nuclear Magnetic Resonance Techniques - Prof R.K. Harris

REFERENCES

1. G. C. Finger, *Advan. Fluorine Chem.*, 1961, 2, 35.
2. D. B. Harper, J. T. G. Hamilton and D. O'Hagan, *Tet. Lett.*, 1990, 31, 7661.
3. R. A. Peters, R. J. Hall, P. F. V. Ward and N. Sheppard, *Biochim. J.*, 1960, 77, 17.
4. P. F. V. Ward, *Nature*, 1964, 201, 611.
5. G. O. Morton, J. E. Lancaster, G. E. V. Lear, W. Fulmar and W. E. Meyer, *J. Am. Chem. Soc.*, 1969, 91, 1535.
6. S. Smith, *Preparation, Properties and their Industrial Applications of Organofluorine Compounds*, Ellis Horwood, Chichester, 1979.
7. R. F. Anderson and J. O. Punderson, *Organofluorine Compounds and Their Industrial Applications*, Ellis Horwood, Chichester, 1982.
8. D. E. Bergstrom and D. J. Swartling, *Fluorine Containing Molecules. Structure, Synthesis and Applications*, VCH, 1988.
9. G. Pantini and A. Antonini, *Drug Cosmet. Ind.*, 1988, 143, 34.
10. T. Atwood, *Int. J. Refrig.*, 1988, 11, 234.
11. H. Schatz, *Forschingsber - Forschungsstelle Brandschutztech. Univ. Karlsruhe*, 1978, 32, 79.
12. P. D. Temmerman, *Excerpta Med. Int. Congr. Ser.*, 1974, 347, 177.
13. P. Brown, *Metal Finish*, 1969, 67, 44.
14. P. E. Cassidy, T. M. Aminabhavi and J. M. Farley, *JMS Rev. Macromol. Chem. Phys.*, 1989, 29, 365.
15. R. P. Geyer, presented at the Prog. Artificial Organs, 1985.
16. M. Guyoy and C. Doutremepuich, *J. Pharmacie Belg.*, 1990, 45, 196.
17. T. L. Cottrell, *The Strengths of Chemical Bonds*, Butterworths Scientific Publications, London, 1958.
18. C. Heidelberger, P. V. Danenberg and R. G. Moran, *Adv. Enzymol. Relat. Areas Mol. Biol.*, 1983, 54, 57.
19. A. Polak, *Zentralbl. Bakteriol., Parasitenkd., Infektionskr. Hyg., Abt. 1 suppl.*, 1980, 8, 269.
20. D. E. Bergstrom and D. J. Swartling, *Mol. Struct. Energ.*, 1988, 8, 259.
21. G. M. Blackburn and M.-J. Guo, *Nuc. & Nuc.*, 1991, 10, 549.
22. Y. Abe, H. Fukuda, K. Ishiwata, S. Yoshioka, K. Yamada, S. Endo, T. Kubota, T. Sato, T. Matsuzawa, T. Takahashi and T. Ido, *Eur. J. Nucl. Med.*, 1983, 8, 258.
23. K. Saito, G. A. Digeuis, A. A. Hawi and J. Chaney, *J. Fluorine Chem.*, 1987, 35, 663.
24. G. A. Digenis, A. A. Hawi, H. Yip and W. J. Layton, *Life Sciences*, 1986, 38, 2307.
25. H. M. Walborsky and M. E. Baum, *J. Am. Chem. Soc.*, 1958, 80, 187.

26. D. Shugar, *Antimetabolites in Biochemistry, Biology, and Medicine*, Pergamon Press, Oxford, 1979.
27. D. Arlt, M. Jautelat and R. Lantzch, *Angew. Chem., Int. Ed. Eng.*, 1981, **20**, 703.
28. B. C. Saunders, *Advances in Fluorine Chemistry*, Butterworth, London, 1961.
29. M. R. C. Gerstenberger and A. Haas, *Angew. Chem., Int. Ed. Eng.*, 1981, **20**, 647.
30. D. J. Burton and Z.-Y. Yang, *Tetrahedron*, 1992, **48**, 189.
31. P. W. Atkins, *Physical Chemistry*, Oxford University Press, Oxford, 1987.
32. T. Kitazume, T. Sato and N. Ishikawa, *Chem. Lett.*, 1984, 1811.
33. G. W. Gribble, *J. Chem. Ed.*, 1973, **50**, 460.
34. M. H. Gelb, J. P. Svaren and R. H. Abeles, *Biochemistry*, 1985, **24**, 1813.
35. G. M. Blackburn, D. E. Kent and F. Kolkmann, *J. Chem. Soc., Perkin Trans. I*, 1984, 1119.
36. R. D. Chambers, R. Jaouhari and D. O'Hagan, *J. Chem. Soc., Chem. Commun.*, 1988, 1169.
37. R. D. Chambers, D. O'Hagan, R. B. Lamont and S. C. Jain, *J. Chem. Soc., Chem. Commun.*, 1990, **15**, 1053.
38. C. U. Kim, B. Y. Luh, P. F. Misco, J. J. Bronson, M. J. M. Hitchcock, I. Ghazzouli and J. C. Martin, *J. Med. Chem.*, 1990, **33**, 1207.
39. J. Mann, *Chem. Soc. Rev.*, 1987, **16**, 381.
40. J. B. Hobbs, in *Comprehensive Medicinal Chemistry*, ed. P. G. Sammes, Pergamon Press, Oxford, 1990, vol. 2, p. 299.
41. A. Parkin, personal communication.
42. C. Heidelberger, N. K. Chaudhuri, P. Danneberg, D. Mooren, L. Griesbach, R. Duschinsky, R. J. Schnitzer, E. Plevin and J. Scheiner, *Nature*, 1957, **179**, 663.
43. W. H. Prusoff, *Biochem. Biophys. Acta*, 1959, **32**, 295.
44. C. Heidelberger, D. G. Parsons and D. C. Remy, *J. Am. Chem. Soc.*, 1962, **84**, 3597.
45. E. DeClercq, *Symp. Soc. Gen. Microbiol.*, 1985, **38**, 155.
46. J. Matulic-Adamic, K. A. Watanabe and R. W. Price, *Chemica Scripta*, 1986, **26**, 127.
47. E. DeClercq, J. Descamps, P. DeSommer, P. J. Barr, A. S. Jones and R. T. Walker, *Proc. Natl. Acad. Sci. USA*, 1979, **76**, 2947.
48. P. L. Coe, M. R. Harden, A. S. Jones, S. A. Noble and R. T. Walker, *J. Med. Chem.*, 1982, **25**, 1329.
49. B. Schwarz, D. Cech and J. Reefsclaeger, *J. Prakt. Chemie*, 1984, **326**, 985.
50. J. Goodchild, R. A. Porter, R. H. Raper, I. S. Sim, R. M. Upton, H. J. Wadsworth and J. Viney, *J. Med. Chem.*, 1983, **26**, 1252.
51. A. S. Jones, S. G. Rahim, R. T. Walker and E. DeClerq, *J. Med. Chem.*, 1981,

- 24, 759.
52. L. Parkanyi, A. Kalman, M. Czugler, T. Kovacs and R. T. Walker, *Nucleic Acids Res.*, 1987, **15**, 4111.
53. C.-D. Pein and D. Cech, *Tet. Lett.*, 1985, **28**, 4915.
54. D. J. McNamara and P. D. Cook, *J. Med. Chem.*, 1987, **30**, 340.
55. J. A. Montgomery and K. Hewson, *J. Med. Chem.*, 1969, **12**, 498.
56. M. J. Robins and B. Uznanski, *Can. J. Chem.*, 1981, **59**, 2608.
57. J. A. Montgomery and K. Hewson, *J. Am. Chem. Soc.*, 1960, **82**, 463.
58. R. T. Walker, in *Comprehensive Organic Chemistry*, ed. E. Haslam, Pergamon Press, Oxford, 1979, vol. 5, p. 53.
59. US 4,963,662.
60. V. Nair and G. S. Buenger, *J. Am. Chem. Soc.*, 1989, **111**, 8502.
61. A. G. Beaman and R. K. Robins, *J. Org. Chem.*, 1963, **28**, 2310.
62. J. H. Lister and J. Kiburis, *J. Chem. Soc. C*, 1971, 1587.
63. J. Kiburis and J. H. Lister, *J. Chem. Soc. C*, 1971, 3942.
64. M. J. Robins and G. L. Basom, *Can. J. Chem.*, 1973, **51**, 3161.
65. M. J. Robins and B. Uznanski, *Can. J. Chem.*, 1981, **59**, 2601.
66. P. C. Ratsep, R. K. Robins and M. M. Vaghefi, *Nuc. & Nuc.*, 1990, **9**, 197.
67. JP 62,240,622.
68. P. Herdewijn, A. V. Aerschot and L. Kerremans, *Nuc. & Nuc.*, 1989, **8**, 65.
69. H. Hayakawa, F. Takai, H. Tanaka, T. Miyasaka and K. Yamaguchi, *Chem. Pharm. Bull.*, 1990, **38**, 1136.
70. W. Bergmann and R. J. Feeney, *J. Am. Chem. Soc.*, 1950, **72**, 2809.
71. W. W. Lee, A. Benitez, L. Goodman and B. R. Baker, *J. Am. Chem. Soc.*, 1960, **82**, 2648.
72. K. A. Watanabe, U. Reichman, K. Hirota, C. Lopez and J. J. Fox, *J. Med. Chem.*, 1979, **22**, 21.
73. K. A. Watanabe, T.-L. Su, R. S. Klein, C. K. Chu, A. Matsuda, M. W. Chun, C. Lopez and J. J. Fox, *J. Med. Chem.*, 1983, **26**, 152.
74. V. E. Marquez, *ACS Symposium Series*, 1989, **401**, 140.
75. J. J. Fox, K. A. Watanabe, T. C. Chou, R. F. Schinazi, K. F. Soike, I. Fourel, G. Hantz and C. Trepo, *ACS Symposium Series*, 1988, **374**, 176.
76. K. Biggadike, A. D. Borthwick, A. M. Exall, B. E. Kirk, S. M. Roberts, P. Youds, A. M. Z. Slawina and D. J. Williams, *J. Chem. Soc., Chem. Commun.*, 1987, 251.
77. A. D. Borthwick, S. Butt, K. Biggadike, A. M. Exall, S. M. Roberts, P. M. Youds, B. E. Kirk, B. R. Booth, J. M. Cameron, S. W. Cox, C. L. P. Marr and M. D. Shill, *J. Chem. Soc., Chem. Commun.*, 1988, 656.
78. EP 0 372 268 A1.
79. H. Mitsuya, K. Weinhold, P. A. Furman, M. H. S. Clair, S. Nusinoff-Lehrman,

- R. C. Gallo, D. P. Bolognesi, D. W. Barry and S. Broder, *Proc. Natl. Acad. Sci USA*, 1985, **82**, 7096.
80. P. A. Furman, J. A. Fyfe, M. H. S. Clair, K. Weinhold, J. L. Rideout, G. A. Freeman, S. Nusinoff-Lehrman, D. P. Bolognesi, S. Broder, H. Mitsuya and D. W. Barry, *Proc. Natl. Acad. Sci USA*, 1986, **83**, 8333.
81. G. M. Blackburn, F. Eckstein, D. E. Kent and D. Perree, *Nuc. & Nuc.*, 1985, **4**, 165.
82. J.-T. Huang, L.-C. Chen, L. Wang, M.-H. Kim, J. A. Warshaw, D. Armstrong, Q.-Y. Zhu, T.-C. Chou, K. A. Watanabe, J. Matulic-Adamic, T.-L. Su, J. F. Fox, B. Polsky, P. A. Baron, J. W. M. Gold, W. D. Hardy and E. Zuckerman, *J. Med. Chem.*, 1991, **34**, 1640.
83. G. Etzold, R. Hintsche, G. Kowollik and P. Langen, *Tetrahedron*, 1971, **27**, 2463.
84. H. Baumgartner, M. Bodenteich and H. Griengl, *Tet. Lett.*, 1988, **29**, 5745.
85. J. Béres, G. Sági, E. Baitz-Gács, I. Tömösközi, L. Gruber and L. Ötvös, *Tetrahedron*, 1989, **45**, 6271.
86. DD 158,903.
87. G. Kowollik, K. Gaertner and P. Langen, *J. Carbohydr. Nucl. Nucl.*, 1975, **2**, 191.
88. H. Rosemeyer and F. Seela, *Helv. Chim. Acta*, 1989, **72**, 1084.
89. M. J. Bamford, P. L. Coe and R. T. walker, *J. Med. Chem.*, 1990, **33**, 2488.
90. P. VanRoey, J. M. Salerno, C. K. Chu and R. F. Schinazi, *Proc. Natl. Acad. Sci. USA*, 1989, **86**, 3929.
91. Deutsches Patentamt 2 228 750.
92. G. R. Owen, J. P. H. Verheyden and J. G. Moffatt, *J. Org. Chem.*, 1976, **41**, 3010.
93. S. Ajmera, A. R. Bapat, E. Stephanian and P. V. Danenberg, *J. Med. Chem.*, 1988, **31**, 1094.
94. K. Biggadike and A. D. Borthwick, *J. Chem. Soc., Chem. Commun.*, 1990, 1380.
95. R. B. Gilbertsen and J. C. Sircar, in *Comprehensive Medicinal Chemistry*, ed. P. G. Sammes, Pergamon Press plc, Oxford, 1990, vol. 2, p. 453.
96. M. J. Robins and S. F. Wnuk, *Tet. Lett.*, 1988, **29**, 5729.
97. J. R. McCarthy, E. T. Jarvi, D. P. Matthews, M. L. Edwards, N. J. Prakash, T. L. Bowlin, S. Mehdi, P. S. Sunkara and P. Bey, *J. Am. Chem. Soc.*, 1989, **111**, 1127.
98. G. Modena, *Acc. Chem. Res.*, 1971, **4**, 73.
99. F. Schlenk, *Adv. Enzymol. Related Areas Mol. Biol.*, 1983, **54**, 195.
100. J. R. Sufrin, A. J. Spiess, D. L. Kramer, P. R. Libby, J. T. Miller, R. J. Bernacki, Y. Lee, R. T. Borchardt and C. W. Porter, *J. Med. Chem.*, 1991, **34**, 2600.
101. V. E. Marquez and M.-I. Lim, *Med. Res. Rev.*, 1986, **6**, 1.

102. T. Kusaka, H. Yamamoto, M. Shibata, M. Muroi, T. Kishi and K. Mizuno, *J. Antibiot.*, 1968, **21**, 255.
103. S. Yaginuma, M. Tsujino, N. Muto, M. Otani, M. Hayashi, F. Ishimura, T. Fujii, S. Watanabe, T. Matsuda, T. Watanabe and J. Abe, *J. Curr. Chemother. Infect. Dis., Int. Congr.*, 1980, **2**, 1558.
104. S. Yaginuma, N. Muto, M. Tsujino, Y. Sudate, M. Hayashi and M. Otani, *J. Antibiotics*, 1981, **34**, 359.
105. M. Tsujino, S. Yuginuma, T. Fujii, K. Hayano, T. Matsuda, T. Watanabe and J. Abe, *J. Curr. Chemother. Infect. Dis., Int. Congr.*, 1980, **2**, 1559.
106. M.-I. Lim, J. D. Moyer, R. L. Cysky and V. E. Marquez, *J. Med. Chem.*, 1984, **27**, 1536.
107. M. Arita, K. Adachi and M. Ohno, *Nucleic Acid Res., Symp. Ser.*, 1983, **12**, 25.
108. J. A. Fyfe, P. M. Keller, P. A. Furman, R. L. Miller and G. B. Elion, *J. Biol. Chem.*, 1978, **253**, 8721.
109. A. D. Borthwick and K. Biggadike, *Tetrahedron*, 1992, **48**, 571.
110. US 4,605,659.
111. A. D. Borthwick, B. E. Kirk, K. Biggadike, A. M. Exall, S. Butt, S. M. Roberts, D. J. Knight, J. A. V. Coates and D. M. Ryan, *J. Med. Chem.*, 1991, **34**, 907.
112. M. S. Levitt, R. F. Newton, S. M. Roberts and A. J. Willetts, *J. Chem. Soc., Chem. Commun.*, 1990, 619.
113. R. M. Highcock, H. Hilpert, P. L. Myers, S. M. Roberts and R. Storer, *J. Chem. Soc., Perkin Trans. I*, 1991, 1127.
114. H. J. Schaeffer, L. Beauchamp, P. deMiranda, G. B. Elion, D. J. Bauer and P. Collins, *Nature*, 1978, **272**, 583.
115. K. K. Ogilvie, U. O. Cheriyan, B. K. Radatus, K. O. Smith, K. S. Galloway and W. L. Kennell, *Can. J. Chem.*, 1982, **60**, 3005.
116. D. Derse, Y.-C. Cheng, P. A. Furman, M. H. S. Clair and G. B. Elion, *J. Biol. Chem.*, 1981, **256**, 11447.
117. P. Vemishetti, R. Saibaba, R. P. Panzica and E. Abushanab, *J. Med. Chem.*, 1990, **33**, 681.
118. P. Bravo, G. Resnati and F. Viani, *Tetrahedron*, 1993, **49**, 713.
119. D. W. Hutchinson, in *Comprehensive Organic Chemistry*, ed. E. Haslam, Pergamon Press, Oxford, 1979, vol. 5, p. 105.
120. R. Wittmann, *Chem. Ber.*, 1963, **96**, 771.
121. C. Sund and J. Chattopadhyaya, *Tetrahedron*, 1989, **45**, 7523.
122. H. J. Vogel and W. A. Bridger, *Biochemistry*, 1982, **21**, 394.
123. S. G. Withers and N. B. Madsen, *Biochem. Biophys. Res. Commun.*, 1980, **97**, 513.
124. G. M. Blackburn and M. J. Parratt, *J. Chem. Soc., Chem. Commun.*, 1983, 886.
125. EP 0 339 161 A1.

126. EP 0 338 168 A1.
127. G. M. Blackburn, T. D. Perrée and A. Rashid, *Chemica Scripta*, 1986, 26, 21.
128. A. Guranowski, E. Starzynska, G. E. Taylor and G. M. Blackburn, *Biochem. J.*, 1989, 262, 241.
129. G. M. Blackburn, A. Guranowski, M.-J. Guo, A. G. McLennan and G. E. Taylor, *Phosphorus, Sulfur, and Silicon*, 1990, 51/52, 31.
130. A. G. McLennan, G. E. Taylor, M. Prescott and G. M. Blackburn, *Biochemistry*, 1989, 28, 3868.
131. G. M. Blackburn and S. P. Langston, *Tet. Lett.*, 1991, 32, 6425.
132. G. M. Blackburn, G. E. Taylor, G. R. J. Thatcher, M. Prescott and A. G. McLennan, *Nucleic Acids Research*, 1987, 15, 6991.
133. G. M. Blackburn, M.-J. Guo, S. P. Langston and G. E. Taylor, *Tet. Lett.*, 1990, 31, 5637.
134. G. M. Blackburn and M.-J. Guo, *Tet. Lett.*, 1990, 31, 4371.
135. D. Hebel, K. L. Kirk, J. Kinjo, T. Kovacs, K. Lesiak, J. Balzarini, E. D. Clercq and P. F. Torrence, *Bioorganic & Medicinal Chemistry Letters*, 1991, 1, 357.
136. D. Bergstrom, E. Romo and P. Shum, *Nuc. & Nuc.*, 1987, 6, 53.
137. EP 0 335 770 A2.
138. P. J. Casara, K. C. Jund, A. Clauss, J.-F. Navé and R. D. Snyder, *Bioorganic & Medicinal Chemistry Letters*, 1992, 2, 145.
139. T. Fukui, N. Kakiuchi and M. Ikehara, *Biochem. Biophys. Acta*, 1982, 697, 174.
140. D. E. Bergstrom and P. W. Shum, *J. Org. Chem.*, 1988, 53, 3953.
141. D. Wolff-Kugel and S. Halazy, *Tet. Lett.*, 1991, 32, 6341.
142. D. J. Burton, R. Takei and S. Shin-Ya, *J. Fluorine Chem.*, 1981, 18, 197.
143. D. J. Burton and R. M. Flynn, *J. Fluorine Chem.*, 1977, 10, 329.
144. D. J. Burton, T. Ishihara and M. Maruta, *Chem. Lett.*, 1982, 755.
145. D. J. Burton, A. S. Modak, R. Guteratne, D. Su, W. Cen, R. L. Kirchmeier and J. M. Shreeve, *J. Am. Chem. Soc.*, 1989, 111, 1773.
146. WO 90/07513.
147. D. J. Burton and L. G. Sprague, *J. Org. Chem.*, 1988, 54, 613.
148. M. Obayashi, E. Ito, K. Matsui and K. Kondo, *Tet. Lett.*, 1982, 23, 2323.
149. W. Cen and Y. Shen, *J. Fluorine Chem.*, 1991, 52, 369.
150. C. E. McKenna and P.-D. Shen, *J. Org. Chem.*, 1981, 46, 4573.
151. US 4,478,763.
152. D. J. Rowe and L. A. Etre, *Bone*, 1988, 9, 1988.
153. G. M. Blackburn, D. Brown, S. J. Martin and M. J. Parratt, *J. Chem. Soc., Perkin Trans. I*, 1987, 181.
154. E. Differding, R. O. Duthaler, A. Krieger, G. M. Rüegg and C. Schmit, *Synthetic Letters*, 1991, 395.

155. R. D. Chambers, R. Jaouhari and D. O'Hagan, *J. Fluorine Chem.*, 1989, **44**, 275.
156. H. Nozaki, T. Shirafuji and Y. Yamamoto, *Tetrahedron*, 1969, **25**, 3461.
157. L. G. Sprague, D. J. Burton, R. D. Guneratne and W. E. Bennett, *J. Fluorine Chem.*, 1990, **49**, 75.
158. L. F. Hatch and G. Bachmann, *Chem. Ber.*, 1964, **97**, 132.
159. L. G. Sprague, Ph.D. Thesis, University of University of Ohio, 1986.
160. M. Maruta, 1992, Unpublished results.
161. D. H. R. Barton, R. C. Cookson, W. Klyne and C. W. Shoppee, *Chemistry and Industry*, 1954, 21.
162. R. M. Silverstein, G. Clayton and T. C. Morrill, *Spectrometric Identification of Organic Compounds*, John Wiley and Sons, New York, 1981.
163. B. M. Trost and T. R. Verhoeven, *J. Am. Chem. Soc.*, 1980, **102**, 4730.
164. C. F. Wilcox and S. S. Chibber, *J. Org. Chem.*, 1962, **27**, 2209.
165. M. Kato, M. Kogeyama, R. Tanaka, M. Kumahara and A. Yoshikoshi, *J. Org. Chem.*, 1975, **40**, 1932.
166. G. Consiglio, O. Piccolo, L. Roncetti and F. Morandini, *Tetrahedron*, 1986, **42**, 2043.
167. R. B. Moffat, *Organic Syntheses*, 1952, **32**, 41.
168. G. Frater and H. Schmid, *Helv. Chim. Acta.*, 1967, **50**, 255.
169. B. M. Trost, T. J. Dietsche and T. J. Fullerton, *J. Org. Chem.*, 1974, **39**, 737.
170. Z.-Y. Yang and D. J. Burton, *Tet. Lett.*, 1991, **32**, 1019.
171. M. Obayashi and K. Kondo, *Tet. Lett.*, 1982, **23**, 2327.
172. Caldwell, Magnera and Kebarle, *J. Am. Chem. Soc.*, 1984, **106**, 959.
173. D. J. Burton, T. Ishihara and R. M. Flynn, *J. Fluorine Chem.*, 1981, **20**, 121.
174. J. S. Brimacombe, P. A. Gent and M. Stacey, *J. Chem. Soc. (C)*, 1968, 567.
175. W. A. Szarek, G. W. Hay and B. Doboszewski, *J. Chem. Soc. (C)*, 1985, 663.
176. B. J. Wakefield, in *Organolithium Methods*, Pergamon Press, Oxford, 1988, p. 113.
177. M. Hudlicky, *Oxidations in Organic Chemistry*, American Chemical Society, Washington, 1990.
178. H. B. Henbest and R. A. L. Wilson, *J. Chem. Soc.*, 1957, 1958.
179. M. Hudlicky, *J. Fluorine Chem.*, 1987, **36**, 373.
180. Fatiadi, *Synthesis*, 1987, **85**, 86.
181. M. Schröder, *Chem. Rev.*, 1980, **80**, 187.
182. V. VanRheenen, R. C. Kelly and D. Y. Cha, *Tet. Lett.*, 1976, 1973.
183. B. K. Sharpless and T. R. Verhoeven, *Aldrichimica Acta.*, 1979, **12**, 63.
184. D. O'Hagan, personal communication.
185. R. B. Woodward and F. V. Brutcher, *J. Am. Chem. Soc.*, 1958, **80**, 209.
186. G. R. Green, M. R. Harnden and M. J. Parratt, *Bioorganic & Medicinal*

- Chemistry Letters*, 1991, **1**, 347.
187. W. A. Slusarchyk, M. G. Young, G. S. Bisacchi, D. R. Hockstein and R. Zahler, *Tet. Lett.*, 1989, **30**, 6453.
188. Y. F. Shealy, C. A. O'Dell, W. M. Shannon and G. Arnett, *J. Med. Chem.*, 1984, **27**, 1416.
189. I. Kitagawa, B. C. Cha, T. Nakae, Y. Okaichi, Y. Takinami and M. Yoshikawa, *Chem. Pharm. Bull.*, 1989, **37**, 542.
190. H. Hoshino, N. Shimizu, N. Shimada, T. Takita and T. Takeuchi, *J. Antibiotics*, 1987, **40**, 1077.
191. Y. Wang, G. W. J. Fleet, F. X. Wilson, R. Storer, P. L. Myers, C. J. Wallis, O. Doherty, D. J. Watkin, K. Vogt and J. M. Peach, *Tet. Lett.*, 1991, **32**, 1675.
192. J. Zemlicka, J. V. Freisler, R. Gasser and J. P. Horwitz, *J. Org. Chem.*, 1973, **38**, 990.
193. V. E. Marquez, M. Lim, S. P. Treanor, J. Plowman, M. A. Priest, A. Markovac, M. S. Khan, B. Kaskar and J. S. Driscoll, *J. Med. Chem.*, 1988, **31**, 1687.
194. J. P. Horwitz, J. Chua, M. A. DaRooge, M. Noel and I. L. Klundt, *J. Org. Chem.*, 1966, **31**, 205.
195. Y.-C. Cheng, G. E. Dutschman, K. F. Bastow, M. G. Sarngadharan and R. Y. C. Ting, *J. Biol. Chem.*, 1987, **262**, 2187.
196. R. Vince and M. Hua, *J. Med. Chem.*, 1990, **33**, 17.
197. Y. F. Shealy, C. A. O'Dell, G. Arnett, W. M. Shannon, M. C. Thorpe, J. M. Riordan and W. C. Colburn, *J. Med. Chem.*, 1986, **29**, 1720.
198. O. Mitsunobu, *Synthesis Rev.*, 1981, **1**.
199. K. Biggadike, A. D. Borthwick, A. M. Exall, B. E. Kirk, S. M. Roberts and P. J. Youds, *J. Chem. Soc., Chem. Commun.*, 1987, 1083.
200. J. A. Montgomery and C. Temple, *J. Am. Chem. Soc.*, 1961, **83**, 630.
201. H. J. Bestmann and D. Roth, *Angew. Chem., Int. Ed. Engl.*, 1990, **29**, 99.
202. S. Halazy and V. Gross-Berges, *J. Chem. Soc., Chem. Commun.*, 1992, 743.
203. N. Rabjohn, *Org. React.*, 1976, **24**, 261.
204. D. Arigoni, A. Vasella, K. B. Sharpless and H. P. Jensen, *J. Am. Chem. Soc.*, 1973, **95**, 7917.
205. E. N. Tractenberg and J. R. Carver, *J. Org. Chem.*, 1970, **35**, 1646.
206. C. Djerassi, *Chem. Rev.*, 1948, **43**, 271.
207. A. Wohl, *Ber.*, 1919, **52**, 51.
208. H. J. Duaben and L. L. McCoy, *J. Am. Chem. Soc.*, 1959, **81**, 4863.
209. B. P. McGrath and J. M. Tedder, *Proc. Chem. Soc.*, 1961, 80.
210. R. E. Pearson and J. C. Martin, *J. Am. Chem. Soc.*, 1963, **85**, 3142.
211. C. Walling, in *Molecular Rearrangements*, ed. P. DeMayo, Interscience, New York, 1963, vol. 1, p. 431.
212. H. J. Schaeffer and R. D. Weimar, *J. Am. Chem. Soc.*, 1959, **81**, 197.

213. J. H. Lister, *Purines*, Wiley-Interscience, New York, 1971.
214. R. H. DeWolfe and W. G. Young, *allylic reactions*, Interscience, New York, 1964.
215. R. Wasylishen and T. Schaeffer, *Can. J. Chem.*, 1973, **59**, 961.
216. K. K. Ogilvie and M. F. Gillen, *Tet. Lett.*, 1980, **21**, 327.
217. M. Vaultier, N. Knouzi and R. Carrié, *Tet. Lett.*, 1983, **24**, 763.
218. J. March, *Advanced Organic Chemistry*, Wiley-Interscience, New York, 1985.
219. E. Kober, H. Schroeder, R. F. W. Rätz, H. Ulrich and C. Grundmann, *J. Org. Chem.*, 1962, **27**, 2577.
220. N. Kos, H. C. Van Der Plas and A. V. Veldhuizen, *Recl. Trav. Chim. Pays-Bas*, 1980, **99**, 267.
221. H. J. Schaeffer and R. Vince, *J. Med. Chem.*, 1965, **8**, 710.
222. M. Jung and M. Lyster, *J. Org. Chem.*, 1977, **42**, 3761.
223. R. T. Walker, *Ann. Reports Chem. Soc.*, 1972, **69B**, 531.
224. US 3,091,648.
225. US 3,145,222.
226. US 3,240,825.
227. W. O. Godtfresden and S. Vangedal, *Acta. Chem. Scand.*, 1961, **15**, 1786.
228. R. N. Haszeldine, *J. Chem. Soc.*, 1949, 2856.
229. R. N. Haszeldine, *J. Chem. Soc.*, 1951, 588.
230. P. Tarrant and E. G. Gillman, *J. Am. Chem. Soc.*, 1954, **76**, 5423.
231. J. W. Coomber and E. Whittle, *Trans. Faraday Soc.*, 1967, **63**, 2656.
232. R. N. Haszeldine, D. L. Hobson and D. R. Taylor, *J. Fluorine Chem.*, 1975, **8**, 115.
233. R. F. Hudson, *Angew. Chem., Int. Ed. Engl.*, 1973, **12**, 36.
234. C. Walling and M. J. Mintz, *J. Am. Chem. Soc.*, 1967, **89**, 1515.
235. R. D. Chambers, B. Grievson and N. M. Kelly, *J. Chem. Soc., Perkin Trans. I*, 1985, 2209.
236. D. C. Nonhebel and J. C. Walton, *Free-Radical Chemistry*, Cambridge University Press, Cambridge, Mass., 1974.
237. P. S. Skell and K. J. Shea, *Free Radicals*, John Wiley and Son, New York, 1973.
238. Z.-Y. Yang and D. J. Burton, *J. Org. Chem.*, 1992, **57**, 4676.
239. J. March, *Advanced Organic Chemistry*, Wiley-Interscience, New York, 1985.
240. O. Paleta, presented at the Xth European Symposium on Fluorine Chemistry, Padua, 1992.
241. W. M. Moore, G. S. Hammond and R. P. Foss, *J. Am. Chem. Soc.*, 1961, **83**, 2789.
242. E. N. Okafo and E. Whittle, *Int. J. Chem. Kinet.*, 1975, **7**, 287.
243. O. Buchardt, *Photochemistry of Heterocyclic Compounds*, Wiley-Interscience,

New York, 1976.

244. T. Taguchi, O. Kitagawa, T. Morikawa, T. Nishiwaki, H. Uehara, H. Endo and Y. Kobayahi, *Tet. Lett.*, 1986, **27**, 6103.
245. X. Lu, S. Ma and J. Zhu, *Tet. Lett.*, 1988, **29**, 5129.
246. S. Ma and X. Lu, *Tetrahedron*, 1990, **46**, 357.
247. W. M. Latimer, *Oxidation Potentials*, Prentice Hall, New York, 1952.
248. R. B. Meyer and C. H. Levenson, *Biochem. Pharmacol.*, 1980, **29**, 665.
249. S. A. Hiller, R. A. Zhuk and M. Y. Lldak, *Dokl. Akad. Nauk. (USSR)*, 1967, **176**, 332.
250. R. A. Earl and L. B. Townsend, *J. Hetrocyclic Chem.*, 1972, **9**, 1141.
251. M. Miwa, A. Cook and H. Ishitsuka, *Chem. Pharm. Bull.*, 1986, **34**, 4225.
252. R. D. Chambers, N. Kelly and W. K. R. Musgrave, *J. Fluorine Chem.*, 1980, **16**, 351.
253. R. D. Chambers and B. Grievson, *J. Chem. Soc., Perkin Trans. I*, 1985, 2215.
254. A. K. Joel, Ph D Thesis, University of Durham University, 1992.
255. V. Dedek and J. Fika, *Collect. Czech. Chem. Commun.*, 1990, **55**, 2339.
256. D. J. Pasto, R. krasnsnsky and C. Zercher, *J. Org. Chem.*, 1987, **52**, 3062.
257. X.-K. Jiang, X.-Y. Li and K.-Y. Wang, *J. Org. Chem.*, 1989, **54**, 5648.
258. L. J. Altman and B. W. Nelson, *J. Am. Chem. Soc.*, 1969, **91**, 5163.
259. J. Jacobus and D. Pensak, *J. Chem. Soc., Chem. Commun.*, 1969, 400.
260. P. S. Skell, D. L. Tuleen and P. D. Radio, *J. Am. Chem. Soc.*, 1963, **85**, 2849.
261. US 3,816,286.
262. D. E. Bergstrom, M. W. Ng and J. J. Wong, *J. Chem. Soc., Perkin Trans. I*, 1983, 741.
263. H. Muramatsu, H. Kimoto and K. Inukai, *Bull. Chem. Soc. Jpn*, 1969, **42**, 1155.
264. H. Muramatsu, J. Inukai and T. Ueda, *Bull. Chem. Soc. Jpn.*, 1967, **40**, 903.
265. H. Muramatsu, K. Inukai and T. Ueda, *J. Org. Chem.*, 1964, **29**, 2220.
266. V. Dedek and J. Fikar, *Collect. Czech. Chem. Commun.*, 1969, **34**, 3769.
267. H. G. Viehe, R. Merényi, L. Stella and Z. Janousek, *Angew. Chem., Int. Ed. Engl.*, 1979, **18**, 917.
268. J. Cortieu, J. Jullien and N. T. Lai, *Tetrahedron*, 1976, **32**, 669.
269. R. D. Chambers and B. Grievson, *J. Fluorine Chem.*, 1985, **30**, 227.
270. E. J. Corey and R. H. Wollenberg, *Tet. Lett.*, 1976, **809**, 4701.
271. G. A. Russell, *J. Am. Chem. Soc.*, 1958, **80**, 4987.
272. J. Davoll and B. A. Lowy, *J. Am. Chem. Soc.*, 1951, **73**, 1650.
273. G. E. Hilbert and T. B. Johnson, *J. Am. Chem. Soc.*, 1930, **52**, 2001.
274. E. Z. Wittenburg, *Chem.*, 1964, **4**, 303.
275. U. Neidballa and H. Vorbrüggen, *J. Org. Chem.*, 1974, **39**, 3654.
276. H. Vorbrüggen, H. Krolikiewicz and B. Bennua, *Chem. Ber.*, 1981, **114**, 1234.
277. M. S. Motawia, E. Ahmed, E. B. Pedersen, C. M. Nielsen and P. Ebbesen, *Acta*

Chemica Scandinavica, 1992, **46**, 77.

278. S. Bailey and M. R. Harnden, *Nuc. & Nuc.*, 1987, **6**, 555.

279. O. Varela, G. DeFina and R. M. DeLederkremer, *J. Chem. Research (S)*, 1990, 262.

280. C. K. Chu, V. S. Bhadti, B. Doboszewski, Z. P. Gu, Y. Kosugi, K. C. Pullaiah and P. V. Roey, *J. Org. Chem.*, 1989, **54**, 2217.

281. A. E. Abdel-Megied, P. Hansen, E. B. Pedersen and C. M. Neilsen, *Acta Chem. Scand.*, 1991, **45**, 1060.

282. J. Lau, E. B. Pedersen and C. M. Neilsen, *Acta Chem. Scand.*, 1991, **45**, 616.

283. M. S. Motawia, A. M. El-Torgoman and E. B. Pedersen, *Leibigs Ann. Chem.*, 1991, 879.

284. S. Rozen and C. Gal, *J. Fluorine Chem.*, 1982, **26**, 689.

285. S. Rozen and C. Gal, *J. Org. Chem.*, 1987, **52**, 2769.

286. S. Misaki, *J. Fluorine Chem.*, 1981, **17**, 159.

287. G. W. M. Visser, S. Boele, B. W. V. Halteren, G. H. J. N. Knops, J. D. M. Herscheid, G. A. Brinkman and A. Hoekstra, *J. Org. Chem.*, 1986, **51**, 1466.

288. Aldrich, *Aldrich Catalogue Handbook of Fine Chemicals*

289. Z. Soborovskii and N. F. Baina, *J. Gen. Chem. USSR*, 1959, **29**, 1115.