



Durham E-Theses

Excavated sixteenth century glass from five English towns: a preliminary investigation of status and the role of the glass in the social context of dining.

Willmott, Hugh Benedict

How to cite:

Willmott, Hugh Benedict (1995) *Excavated sixteenth century glass from five English towns: a preliminary investigation of status and the role of the glass in the social context of dining.*, Durham theses, Durham University. Available at Durham E-Theses Online: <http://etheses.dur.ac.uk/5317/>

Use policy

The full-text may be used and/or reproduced, and given to third parties in any format or medium, without prior permission or charge, for personal research or study, educational, or not-for-profit purposes provided that:

- a full bibliographic reference is made to the original source
- a [link](#) is made to the metadata record in Durham E-Theses
- the full-text is not changed in any way

The full-text must not be sold in any format or medium without the formal permission of the copyright holders.

Please consult the [full Durham E-Theses policy](#) for further details.

Excavated Sixteenth Century Glass from Five English Towns.

**A preliminary investigation of status and the role
of the glass in the social context of dining.**

Hugh Benedict Willmott

Thesis submitted for the degree of Master of Arts

The copyright of this thesis rests with the author.
No quotation from it should be published without
his prior written consent and information derived
from it should be acknowledged.

**University of Durham
Department of Archaeology
1995**



15 AUG 1996

STATEMENT OF COPYRIGHT

The copyright of this thesis rests with the author. No quotation from it should be published without his prior written consent and information derived from it should be acknowledged

ABSTRACT

Excavated Sixteenth Century Glass from Five English Towns, a preliminary investigation of status and the role of the glass in the social context of dining.

Hugh Benedict Willmott

Thesis submitted for the degree of Master of Arts

University of Durham

Department of Archaeology

1995

This thesis addresses two broad aims. Firstly it attempts to construct a typology of glass vessel types used in England in the sixteenth century. There is no comprehensive guide to the glass from this period commonly found in archaeological contexts and this thesis goes some of the way to redressing this imbalance. Secondly this research undertakes a preliminary investigation of the social context of the glass. It attempts to ascertain what cultural value it would have had within the sixteenth century and this is achieved by examination of its context in archaeological excavations.

For the purpose of this thesis glass from five urban centres in the south east of England are examined, these being Southampton, Winchester, Oxford, Northampton and Colchester. Several groups of glass from each town are taken from sites with good contexts and are examined not only in isolation but also in consideration of the site as a whole.

This approach allows the construction of a typology of vessel types based upon the glass found at these five centres. This covers almost all of the most commonly found vessel forms and includes a variety of imported vessels as well. The establishment of this initial typology provides a framework onto which further research can be based. It is the first stage in the greater understanding of the chronology and development of vessel forms in the sixteenth century.

Finally this thesis examines the wider cultural context of the glass. The types of vessels made in glass are explored and a predominance of vessels associated with liquids noted. Variations between the form of the vessel and type of glass used to make it are observed. The deposition of groups of drinking vessels, apparently in good condition, are considered whilst conclusions concerning the general increase in the occurrence of glass from around 1550 onwards are discussed. Finally comparisons concerning social theory and dining are contrasted with the material found from the study sites.

*"I could write about our style of feasting...from such compilations
posterity would derive unique assistance"*
Michel de Montaigne, 1588.

Table of Contents

Acknowledgements	vi
Figures	vii
Chapter 1: Introduction	1
Chapter 2: Southampton	12
a) Wacher Site 'E'	14
b) The High Street	22
c) Woollen Hall	26
d) St. Michael's House	31
Chapter 3: Winchester	34
a) Victoria Road	34
b) St. John's Street	37
c) Wolvesey Palace	41
d) Brook Street	45
Chapter 4: Oxford	51
a) 31-34 Church Street	51
b) 124 High Street	58
Chapter 5: Northampton	63
a) St. Peter's Street	63
b) Marefair	80
c) Mayorhold	84
d) Canons Ashby	86

Chapter 6: Colchester	94
a) Middleborough	94
b) Lion Walk Court	98
c) Culver Street	109
d) Cups Hotel	115
e) Long Wyre	118
Chapter 7: A Typology of Vessel Types	123
a) Beakers	123
b) Goblets	131
c) Flasks and Bottles	139
d) Urinals	145
e) Lamps	148
Chapter 8: The Social Context of the Glass	150
a) Glass Vessel Types	152
b) Variations Between Vessel Type and Metal	153
c) Group Deposits of Drinking Vessels	155
d) General Increase in the Use of Glass from 1550 Onwards	157
e) Social Theory and Dining	158
Chapter 9: Conclusion	164
Glossary	169
Bibliography	172

Acknowledgements

I would firstly like to acknowledge and thank all of those who allowed me to examine their collections of glass and gave me additional support and information, Duncan Brown from Southampton Archaeology, Helen Rees from the Winchester Museums Service, Jonathan Wallis and David Pearson from the Oxford Museum Store and Mark Curteis from the Central Museum, Northampton. John Cotter provided additional documentary information concerning the excavations at Colchester and Andrew Elkerton supplied me with the information on the glass from the Mary Rose.

Secondly my thanks must go to the Department of Archaeology at Durham and the Rosemary Cramp fund which financially supported my research. Additional thanks are due to Sally Cottam, Yvonne Beadnell and Trevor Woods from the department for their technical assistance. The support of the other post graduates and my family were gratefully received.

My final thanks must however go to Rachel Tyson who answered my seemingly endless questions about medieval vessel glass; and my supervisors Jenny Price and Matthew Johnson who demonstrated the constant faith and support which helped me steer this thesis to its conclusion.

Figures

1) Location of study sites.	3
2) Southampton site location plan.	13
3) Wachter site 'E' plan.	15
4) Wachter site 'E' pit 8 glass.	16
5) Verzelini Glasses.	18
6) Wachter site 'E' pit 39 glass.	21
7) High Street plan.	23
8) High Street glass.	25
9) Woollen Hall plan.	27
10) Woollen Hall glass.	29
11) St. Michael's House glass.	32
12) Winchester site location plan.	35
13) Victoria Road and St. John's Street glass.	38
14) Wolvesey Palace plan.	42
15) Wolvesey Palace glass.	44
16) Brook Street plan.	46
17) Brook Street glass.	48
18) Oxford site location plan.	52
19) Church Street plan.	53
20) Church Street glass.	55
21) High Street glass.	59
22) Northampton site location plan.	64
23) Speed's map of Northampton.	65
24) St. Peter's Street plan.	67
25) House 7 plan and glass.	70
26) House 9 plan and glass.	72

27) House 10 plan and glass.	76
28) Trench 'E' plan and glass.	79
29) Marefair Plan.	81
30) Marefair & Mayorhold glass.	83
31) Mayorhold plan.	85
32) Canons Ashby general plan.	87
33) Canons Ashby excavation plan.	88
34) Canons Ashby glass.	90
35) Colchester site location plan.	95
36) Middleborough plan and glass.	96
37) Lion Walk plan.	99
38) Lion Walk area 'B' and 'K' pit F15 glass.	101
39) Lion Walk case bottle.	103
40) Lion Walk glass.	106
41) Culver Street plan.	110
42) Culver Street glass.	112
43) Cups Hotel Plan.	116
44) Cups Hotel and Long Wyre glass.	117
45) Long Wyre plan.	119
46) Colchester Wafelbeker.	122
47) Beakers.	124
48) Optic Moulds.	127
49) Low Country Beakers.	129
50) Goblets.	133
51) Mould Blown Stems.	137
52) Flasks.	140
53) Mary Rose Flask.	142

54) Urinal and Lamp.	146
55) Sir Henry Unton Feasting.	159

All the illustrations are the product of the author, unless stated here. Figures 3, 7 and 9 come from Platt (1975) whilst figures 14 and 16 come from Biddle (1990). Figure 19 was taken from Hassall (1984) and figures 23-29 from Williams (1979). Figures 32-33 come from Taylor (1974). Figures 36-37 are from Crummy (1984) whilst figures 41, 43 and 45 come from Crummy (1992). Figure 48 comes from a; Henkes (1994), b; Braumgartner (1988), c; Hoover (1950). The unpublished mould blown stems, figure 51, were drawn by Sue Howarth and the illustration of the Mary Rose flask was supplied by Andrew Elkerton from the Mary Rose Trust.

Chapter One- Introduction

The aims of this thesis are twofold. First it is intended as an initial step towards the establishment of a typology and chronology for sixteenth century vessel glass in England and also as a preliminary investigation of its use within society. There is currently no established and recognised typology for vessel glass from this period. Previous work has concentrated on either the material derived from furnace sites, (Crossley & Aberg 1972) or on more generalised narratives which are primarily based on art history collections (Thorpe 1961; Charleston 1984). The very nature of both these types of investigation results in an incomplete examination of the corpus of sixteenth century glass. It is the intention of this thesis to redress this imbalance and to examine vessel glass from the context of excavation, to provide a more rounded idea of what glass was being used in England in the sixteenth century. Questions of style, decoration and origin are examined by comparison with traditional collections, although it is through the deposition of the glass on archaeological sites that a typology and the first dating system for these vessels is established. This approach is indeed timely as Charleston in this last book on English glass remarked that 'documentary evidence seems to outstrip the archaeological' in the sixteenth century (Charleston 1984: xxxviii).

The second aim of this thesis is to undertake a preliminary investigation of the social value that these vessels held and to attempt to see how they were used in sixteenth century society. Because the glass selected came from identified contexts and structures it is possible to link the glass with its social context and its use. Social theory concerning dining and the use of artifacts (Barthes 1979; Douglas 1982) is contrasted with the evidence of glass vessels from the five study sites. To this end it is primarily the vessels that were directly associated with consumption and dining which are considered in this way, these being the drinking vessels. It has been observed that the sixteenth century was a period where a greater range and specialisation of artifacts were in use at the table (Gaimster 1994: 295), and the implications of this in terms of

the glass are examined. Container vessels, such as flasks and bottles, do not seem to show the wide diversity of form of the consumption vessels and with a few exceptions would not seem to have been so important in terms of social value. This study of the significance of vessels within society is constrained by the limited nature of the study sites, but provides an initial exploration into this area of artifact studies.

To enable the aims of this thesis to be accomplished vessel glass from this period is examined not from just one site but a number of them, so that a larger and more comprehensive picture can be achieved. Five English towns, Southampton, Winchester, Oxford, Northampton and Colchester were chosen and the glass from excavations carried out in them examined. Glass vessels from urban contexts were chosen for several reasons. Urban areas, by the nature of post war redevelopment, have tended to produce large numbers of artifacts of all types, so are ideal for such a survey (Gaimster 1994: 285). These five towns were chosen because, even though they are all located in the South and Midlands, they are of differing natures and importance in the sixteenth century and it was hoped that they would provide a greater variety of types of glass. London, an obvious starting point for such an investigation, was excluded mainly because the quantity of glass recovered from here alone would have been beyond the scope of this thesis and would not have provided a fair balance with material excavated from other towns. The glass from these five urban areas is examined in terms of identification of style, origin and date, and then in the broader context of the type of deposit and site it has come from. For this purpose glass was chosen where ever possible from sites that not only produced good assemblages, but also from sites that could provide as much contextual information.

For the purpose of this thesis the vessel glass was generally investigated at first hand at the respective town museums. Material from Southampton Archaeology Museum Store, Winchester Museums Service, Oxfordshire County Museum Store and Northampton Central Museum was examined. Not all the material from Southampton was accessible for viewing, and this was supplemented with some previously published glass (Platt & Coleman-Smith 1975: 205-226). Similarly the

Figure 1 - Location of the study sites.

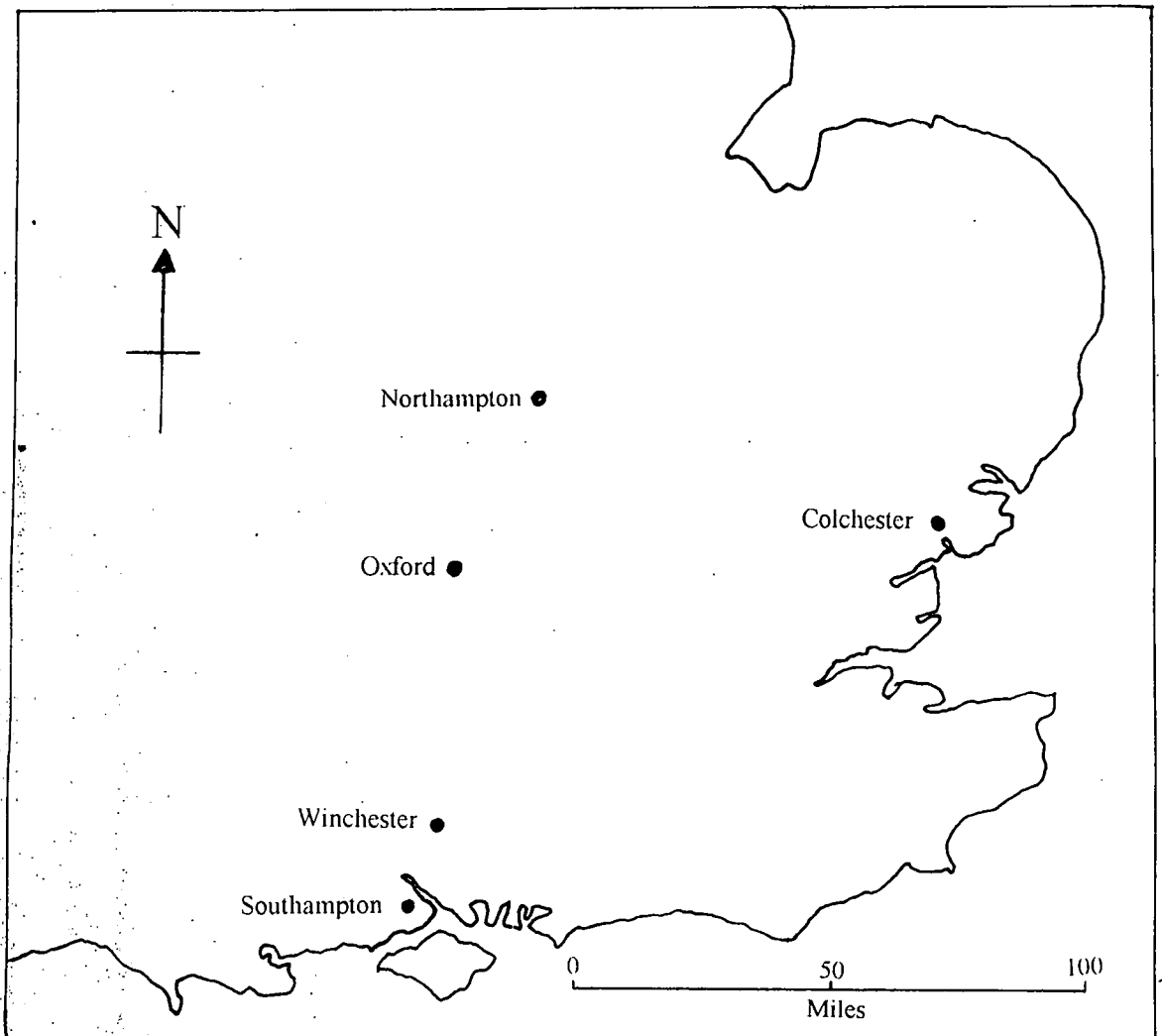

glass from Martin Biddle's excavations in Winchester was unavailable, due to reorganisation of the stores, and material published from his excavations in Winchester has also been used (Biddle 1990). All the post medieval glass derived from the excavations of the Colchester Archaeological Trust between 1971-85 is currently stored at the Department of Archaeology at Durham.

Vessel glass from the sixteenth century retained the same properties as earlier as well as later glass. Glass can be classed as a super cooled liquid, retaining the same molecular structure when cold as whilst it is a liquid (Tait 1991: 8). The inherent fluidity of glass has resulted in its exploitation and forming primarily through the technique of blowing. In the sixteenth century all glass was blown, with some of the vessels being blown into optic and two piece moulds. Glass from any period consists of three basic ingredients: sand, alkali and lime. The sand is the basic component of the structure, whilst the alkali is used as a flux to lower the melting temperature, with the lime acting as a hardening and stabilising agent (Hurst-Vose 1980: 24). In the sixteenth century two basic types of alkali were used as a flux, soda and potash. Soda glass derives its alkali either from traditional sources of the classical world, natron from the Egyptian desert or from dried and crushed plants of the genus *salicornia*, which includes many common seaweeds (Tait 1991: 8). Soda glass is typified by the appearance of a hard resistant metal, which usually was made clear, with a decolourant, in the sixteenth century. This metal often has a slight grey or even pink tint, probably the result of natural contamination of the ingredients of the glass. Soda glass often has colourants and opacifiers added to produce glass which is usually applied as decoration on a clear vessel. It is a general observation that very little vessels found in England were made of completely coloured glass (Charleston 1984: 19). Soda based glasses are often very resistant to weathering when buried in archaeological contexts.

Potash or forest glass uses a less pure form of alkali. This form of glass appears in Northern Europe in the early Middle Ages and is assumed to have developed when traditional sources of soda were no longer freely available. The

potash was derived from burnt twigs and branches, primarily from the beech tree and bracken (Charleston 1984: 18). Consequently its production was limited to small furnaces in forested areas where there was not only close access to the fuel but also the alkali (Godfrey 1975: 157-158). This form of flux was not as pure as soda and contained many impurities which had the effect of causing the finished product always to have a green tint. This green translucent appearance is often the definitive feature of potash glass. It is not so stable as its soda counterpart and is very prone to decaying and opacification in the soil. It would appear that forest glass used to make vessels did not have any colourants added. The presence of crucibles and coloured waste does appear on glass making sites, (Hurst-Vose 1994: 43), although the lack of coloured potash vessels in the archaeological record suggests that these remains relate to window glass production.

It is apparent that the classification of glass by the alkali type is a subjective process. It is not always possible to differentiate heavily weathered soda glass from forest glass in relatively good condition. However it is an important distinction to make due to the fact there is an apparent historical social differentiation between the two types (Godfrey 1975: 187-189). Generally the difference between the two types are sufficiently clear, until the development of coal fired furnaces in the early seventeenth century which produced an all round higher quality of forest glass (op. cit. chapter 3).

Glass from this period has been investigated primarily through the excavation of forest glass houses. The pioneer of these inquiries was the Reverend Thomas Cooper in the early part of this century (Kenyon 1967: 5-11). Cooper was a resident of Chiddingfold in Surrey and his investigations as a local historian recognised the presence of glass making families in the area, through the parish records. He and his family started to look for evidence for the activities of these glass makers and between 1911 and his death in 1918 four sites were investigated and produced evidence of glass working up to the sixteenth century (op. cit. 6). His unpublished book 'History of Chiddingfold' devoted a whole appendix to the glass makers and their activity in

the parish (Kenyon 1967: 6-7). Cooper's work was expanded upon later by the school teacher S.E. Winbolt, who extended the survey to parishes south of Chiddingfold and dug sections through a variety of furnace sites. His work culminated with the publication of 'Wealden Glass' which outlined his recording of furnaces and some of the glass found from them (Winbolt 1933). This material dated from around the fourteenth to the early seventeenth century and Winbolt was the first person to realise the extent of English glass manufacture in the Weald.

The increased interest in medieval and early modern archaeology, particularly in terms of production, stimulated further investigations into the glass working sites. Kenyon's comprehensive study of glass making in the Wealden area of southern England was a direct result from this renewed interest (Kenyon 1967). Kenyon carried on the earlier work of Winbolt and provided a comprehensive examination of glass working sites known through documentary and archaeological sources. He additionally undertook the first detailed analysis of furnace plans and made further extensive surveys of the documented families and individuals concerned with glass making (op. cit. chapter 8). In the 1960s and 1970s other glass house sites were investigated, although the most important of these for the purpose of this research were the excavations of the glass houses in Yorkshire of Hutton and Rosedale by David Crossley (Crossley & Aberg 1972).

These excavations revealed two glass production sites dating from the end of the sixteenth century, but they were more significant than other such investigated sites, in that they produced a large quantity of glass vessel fragments. These probably represented the vessels that were made on the site but which for some reason were broken and kept to be re-melted, (although it is possible that they represent collected cullet). Consequently the report written on this glass by Robert Charleston was the first, and still remains, the most important indication of the nature of English forest glass from this period (Charleston 1972). The vessels recovered from Hutton and Rosedale were the first large group of sixteenth century forest glass to be examined

from an archaeological context, and this report accordingly is frequently referred to in subsequent works, including this thesis.

All studies in sixteenth century glass are inevitably founded to some degree on the art historical traditions of scholarship which evolved at the turn of the century, with Albert Hartshorne and Francis Buckley writing the first accounts of glass from this period (Hartshorne 1897; Buckley 1925). Hartshorne in his extensive survey examined European glass generally but is surprisingly quiet about material from England. In a similar fashion Buckley concentrates on contemporary references, although these, like the bulk of his work, centre around the eighteenth century. The absence from these volumes of material from the sixteenth century can largely be explained by the nature of the material that they concentrate upon. Their scholarship is based on artistic pieces of glass that have survived without ever having been deposited within an archaeological context. Consequently they both wrote extensive dialogues on museum or private collections, in which there is little glass from the sixteenth century.

W.A.Thorpe was the first person who examined glass from the sixteenth century which occurred not only in museums but also from fragments found in the ground. However his first book (Thorpe 1929) still made little mention of glass from this period, with only six vessels being illustrated before 1600 (Charleston 1984: xxvii). This was soon balanced in 1935, when he published the first study that devoted one and a half chapters to sixteenth century material in England and this book went through to its third edition in 1961 (Thorpe 1961: 86-113). Thorpe realised the potential of archaeological material when he states that fragments of glass 'often have more to say of the process and design than entire vessels' (op. cit. 261). Thorpe in this book was also the first person to explore, as fully as possible at the time, the extensive historical sources that related to the later sixteenth century.

It was upon Thorpe's documentary work that Eleanor Godfrey built when she produced her Ph.D. thesis, later published, on 'The Development of English Glassmaking, 1560-1640' (Godfrey 1975). Charleston calls this 'probably the most

important book on English glass to appear since the Second World War', and this is certainly the case on the historical side of sixteenth century glass (Charleston 1984: xxviii). In this work Godfrey deals with the documented revival of English glass making, costs of production, establishment of monopolies and the prices of glass. This work is very important in aiding the understanding of the material culture that is found through archaeology. Although it is not within the scope of this thesis to reiterate her work, there is a brief summary of the important points of documented history of the glass industry in England, from the second half of the sixteenth century, later on in this chapter.

The most important scholar from recent times in the field of sixteenth century glass was Robert Charleston, a former keeper of the Department of Ceramics at the Victoria and Albert Museum. He worked closely with archaeological material and wrote numerous articles and site reports until his death in 1994. Writing from an art historical background he managed to establish a basic framework of glass from this period, although he never developed a precise chronology (Charleston 1984: 42-109). He dealt with the glass as an artifact in itself, but failed to examine it within its archaeological context. His book 'English Glass, and the glass used in England' is the best summation of post Roman glass in England, although it is by no means complete in its coverage of the sixteenth century (Charleston 1984). However Charleston was the first person to attempt to relate excavated material with the historical sources; a point he reinforces when he said that 'It is necessary to piece the record together from the relatively ambiguous archaeological evidence' (Charleston 1984: xxviii).

Documentary sources for glass making in England in the first half of the sixteenth century are very scarce, as is the evidence for extensive home production (op. cit. 42). It is only with the arrival of immigrant glass workers that more comprehensive documents become apparent. The first recorded immigrant glass maker was Jean Carré, a native of Arras who came from Antwerp to London in 1567 (Godfrey 1975: 16). He at once claimed licences from the Queen to build three furnaces, two in the Weald at Alford and one in London (op. cit. 17). By 1568 it

would seem that Carré had formed a fellowship of glass makers and he was even granted a patent to produce window glass on the condition that there was plentiful supply, cheap prices and that they would teach the English the art of making glass. It would seem that this window glass would have most likely been produced in the Wealden forest kilns. It is interesting to see the provision that English glass makers had to be trained, as this does suggest a lack of native glass production in this period. The willingness to grant immigrants such a potentially valuable patent shows how keen the government of Queen Elizabeth was for a home production, presumably to prevent the valuable loss of bullion through import, which was a pressing problem in this period (Godfrey 1975: 20-21).

The London glass furnace was not intended for crown glass production as it is recorded that Carré concentrated most of his effort on his newly established glass house in the abandoned monastery of Crutched Friars where he produced quality soda vessel glass (Charleston 1984: 53). This however was not made with the advantage of a patent or monopoly and would have had to compete on the open market with imported Venetian and north European glass. This was also a restricted luxury product that would have had a limited market, so in 1571 Carré planned for a new forest glass furnace to make drinking glasses. However before this project was finished he died in 1572 (Godfrey 1975: 25). It is most likely that this furnace was continued by Carré's son in law Peter Campe. However during this period the window glass monopoly had been failing due to imports, with as much window glass coming into the port at London in 1572 as had before Carré came to England in 1567 (op. cit. 26). Had Carré lived to see the establishment of his new forest glass furnace it is more than likely that he would have concentrated his efforts on vessel rather than crown glass production.

At Carré's death a Venetian called Jacob Verzelini was the master of the Crutched Friars glass house in London (Charleston 1984: 53). By this stage in 1572 he had probably bought an interest in the furnace, for two years later he was granted by the Crown sole right to manufacture drinking glasses in the Venetian style for twenty one years (Charleston 1984: 54). He was also required to sell the glasses at a cheaper

price than those imported. Unlike the previous patent granted to Carré for window glass Verzelini was also protected by a ban on competing wares from the continent. The ramifications for the archaeological record are potentially important, as this monopoly ensured that theoretically all *soda* glass in England from the period between 1572 and 1592 could only been produced by Verzelini, although this is highly unlikely . It was the case that nobles on visiting a foreign country could apply for licence to bring back certain amounts of glass for their own personal use (Godfrey 1975: 31), however this would in reality constitute a very small quantity of the total glass found through excavation. Despite a disastrous fire at the Crutched Friars furnace which totally destroyed it in 1575, Verzelini was able to rebuild his glass house and apparently fulfil the supply demands (Ibid.) Indeed records show that by 1582 there was a full time resident glass engraver in his employ, a feature that typifies some Verzelini glasses (Charleston 1984: 55). However the large majority of the glass from his furnace was not engraved and may well have followed on from the styles and types produced there under Carré. Production was so successful that Verzelini at this time bought large areas of wooded land in Kent to supply his London furnace (Godfrey 1975: 31). However this does not mean that Verzelini was the only glass maker in operation in this period that produced quality glass. He held the monopoly in Venetian style *soda* and this was rigorously enforced, but other glass houses were producing vessel glass. Indeed a former employee of the Crutched Friars furnace seemingly with Verzelini's blessing established a furnace at Godalming which produced similar vessels but in forest glass (op. cit. 32).

Although the importance of Carré and Verzelini in the history of glass production in this country can not be under estimated, the role of the forest glass tradition was a significant factor in glass production in the sixteenth century. By the 1570s forest glass production was certainly increasing. There were no duties, monopolies or royalties enforced on forest glass and in the 1570s there were apparently imports from abroad suggesting a ready market (Godfrey 1975: 33-35). This combined with the political turbulence on the continent encouraged further the

migration of forest glass workers. Records show new glass houses in this period at Rye, Northiam, Hastings and Buckholt. These would seem to have stayed in the south initially but there was a gradual move into the midlands in the 1580s especially into Staffordshire (Godfrey 1975: 33-35). This historical premise is based on several assumptions, that there was no residual native glass working, that immigrants reintroduced glass making and that it spread as a gradual process diffusion northwards. These are all assumptions that should be examined archaeologically. Although it is probably true that production of quality soda glass was introduced by immigrants it would seem that the local forest glass did continue from the medieval period, albeit on a reduced scale. Archaeologically the presence of the furnaces at Hutton and Rosedale in Yorkshire (Crossley & Aberg 1972) do not bear out the ideas of diffusion of the immigrant glass workers. Indeed many of the forest glass styles do not seem to differ between the early and late halves of the sixteenth century. The documentary evidence used by Charleston and Godfrey does provide an important background to the study of glass in the second half of the sixteenth century. However it is only through the systematic examination of material from archaeological sites that a more comprehensive picture can be established and compared to the documentary evidence.

Chapter 2- Southampton

The site of medieval Southampton lies on the western edge of a peninsula formed by the junction of the rivers the Test and the Ichen. The present day site of Southampton was only occupied in the tenth century and the castle dates from the Norman conquest. A brief summary of the development of medieval Southampton is given in Platt, (1973) which discusses the progress of the town. The importance of this town both strategically and economically was quickly realised and an impressive circuit of town fortifications were in place by the thirteenth century. Indeed until the second world war they remained the most intact circuit of town walls any where in the country, after York. The lay out of the town is typical of the medieval period, with stone houses quickly replacing timber ones in the twelfth century. By the sixteenth century Southampton was a thriving mercantile centre, having particularly benefited from a century of close trading ties with Venice. When Leland visited in the 1530's he remarked that there were many '*fair marchauntes houses*' (Toulin Smith 1906: i:278). During the sixteenth century there was a loosening of ties with the Venetians, although the port still appears to have remained affluent (Ruddock 1951: 206-232).

Southampton has seen a large amount of archaeological excavation in the post war period, the majority of this resulting from the extensive bombing in the 1940s, which laid large areas waste (Platt & Coleman-Smith 1975). A number of archaeologists took advantage of these areas awaiting redevelopment and carried out small excavations where possible (Ibid.). These were generally of a high standard and produced a valuable picture of medieval and early modern Southampton. However, due to the circumstances of their excavation, many of these investigations were limited and were constrained in the information that they could provide. In this chapter not all the sixteenth century glass recovered from Southampton is considered, as a large quantity has been recovered. However four groups from sites, with good contexts, have been chosen from periods throughout the sixteenth century.

Figure 2- Southampton Site Locations

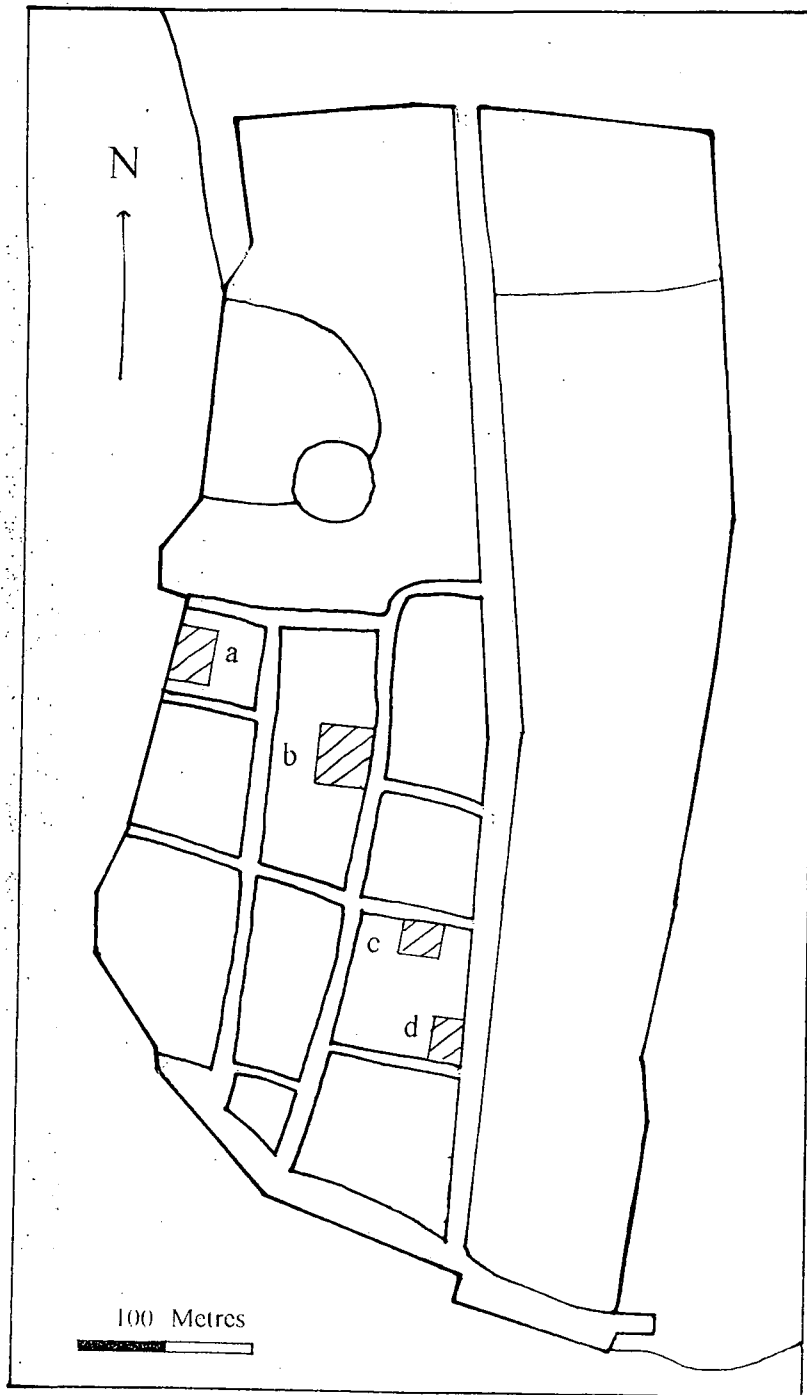

- a: Wollen Hall
- b: St. Michael's House
- c: Site 'E'
- d: High Street

a) Wacher Site 'E'

A series of excavations were undertaken between 1956-58 on bomb damaged properties in Southampton by J.S. Wacher in conjunction with the Ministry of Public Buildings and Works (Platt & Coleman-Smith 1975: 126). Site 'E' was one of these excavations which was located between Brew House Lane and St. John's Lane, figure 3. Trenches 3 and 12 produced evidence for vessel glass. The excavation demonstrated the presence of multiphase buildings, but was too restricted to tell much of their form and chronology. However two pits produced large groups of glass amongst other general household refuse. Pit 8 had a clearly stratified filling, full of tile, wood offcuts and other commonplace waste (op. cit. 173). Amongst this other material were also the fragments from at least ten vessels, these were exclusively beakers and goblets.

PIT 8- Beakers

SF 1562 1 fragment of rim and body of beaker. Rim is upright, body slightly convex. No decoration. Forest glass, green clear. Little weathering
Rim diameter 6 cm. Illustrated fig. 4.

SF 1566 3 fragments (joining) of rim and body of beaker. Rim is slightly everted, body convex. No decoration. Forest glass, green clear. Little weathering.
Rim diameter 7.2 cm. Illustrated fig. 4.

SF 1568 1 fragment of rim of beaker. Rim slightly intumed. No decoration.
Forest glass, green clear. Little weathering.
Rim diameter 6.8 cm. Illustrated fig. 4.

These three beakers are all of ordinary forest glass, probably made in England in the last quarter of the sixteenth century (Thorpe 1961: 91-92). They are common finds on sites of all varieties and generally are associated with the consumption of beer (op. cit. 148-149; Charleston 1984: 87). By themselves these beakers are not of great interest but in conjunction with the other glass material from this context they are shown in a broader perspective.

PIT 8- GOBLETS

SF 1561 1 large fragment of lower bowl of goblet. Side convex. Decorated with mould blown vertical fluting. Applied figure of eight ears low on bowl, possibly one of several on each side (others now lost). Soda glass, clear with a slight green tint. Little weathering.
Illustrated fig. 4.

Figure 3- Wacher Site 'E' Plan

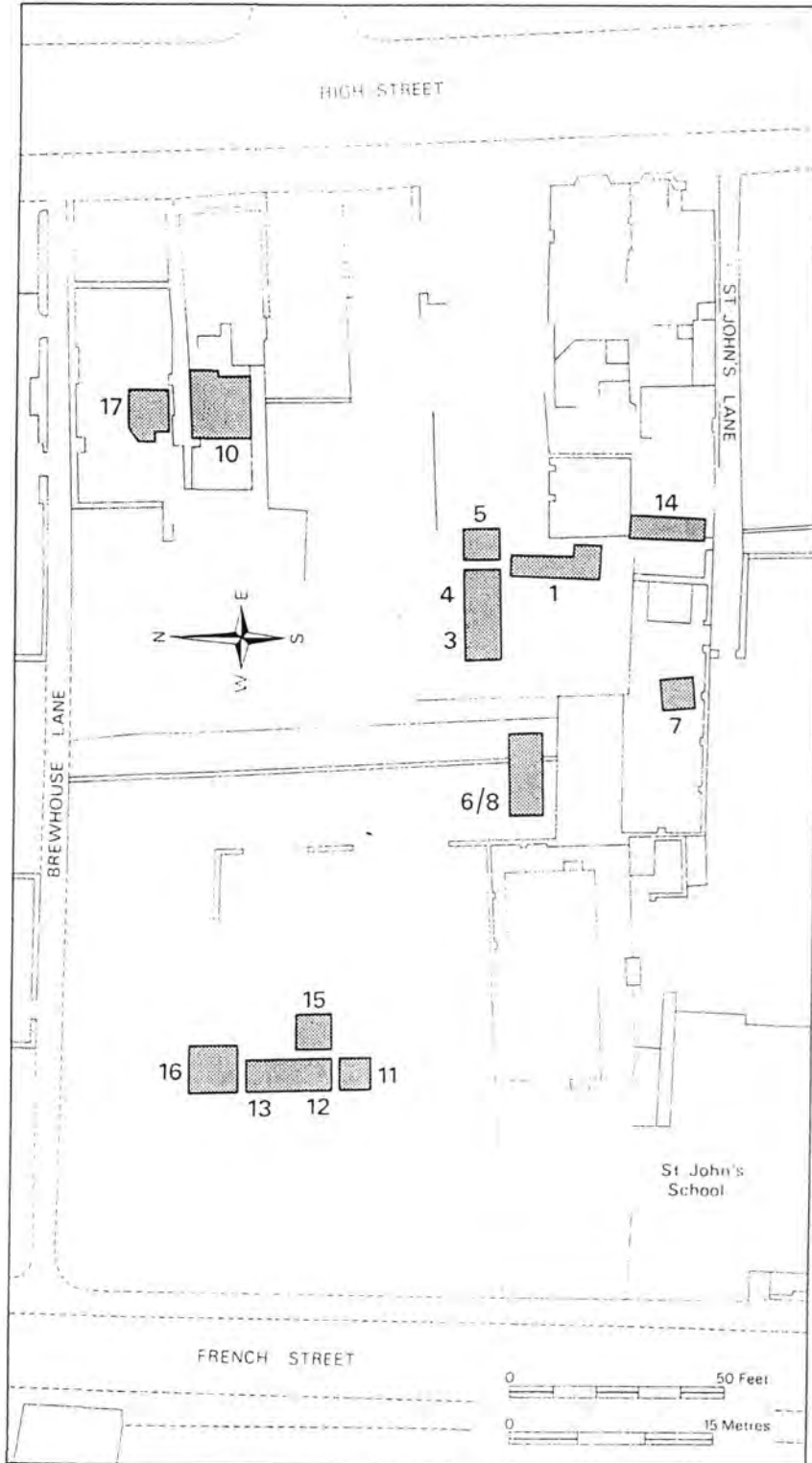
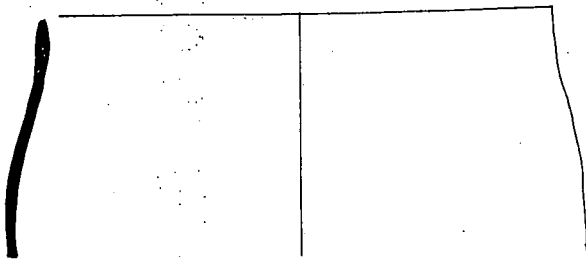
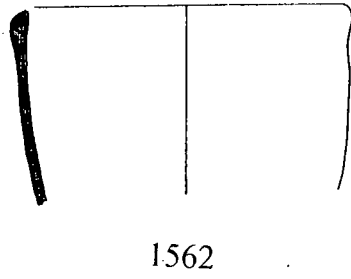
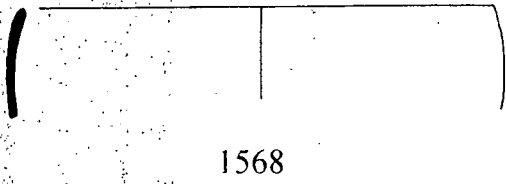
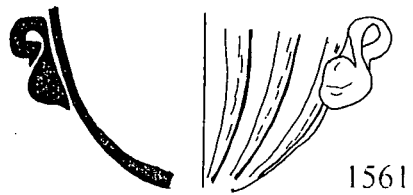
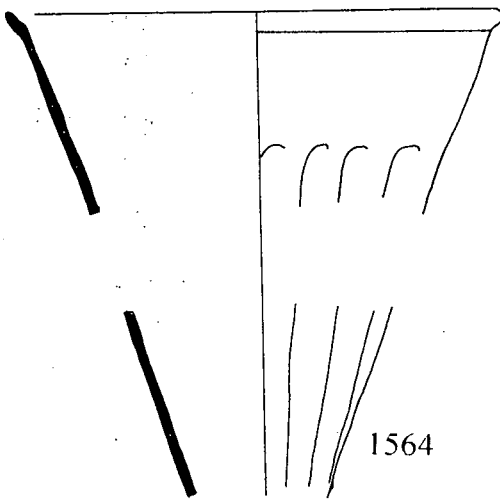
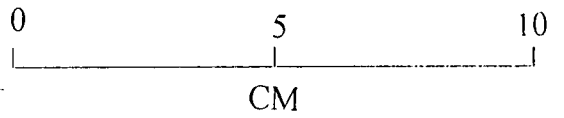

Figure 4- Wachter site 'E' Pit 39 Glass



1566



SF 1564 Several fragments of rim and lower bowl of goblet. Rim everted and bowl straight sided 'trumpet' shape. Decorated with mould blown vertical fluting, starting 2.4 cm below the rim. Soda glass, clear. Little weathering. Rim diameter 8.4 cm. Illustrated fig. 4.

The two goblets are typical late sixteenth century forms and although they probably imports from Northern Europe could well have been made in England (Charleston 1984: 55). This suggestion is supported by the presence of at least two goblets that are of exclusive English manufacture and decoration from this context.

SF 1565 1 large fragment of stem and lower bowl of goblet. Stem is hollow mould blown 'ladder stem' (with eight ladders). Bowl is convex and joined to stem with a flattened knob. No decoration on bowl. Soda glass, clear. Little weathering. Illustrated fig.5.

SF 1557 3 fragments (joining) of rim and bowl of goblet. Rim is upright and bowl is curved and tapering. Decorated with diamond point engraving, possibly from the workshop of Jacob Verzelini. Two main panels of decoration. Top panel, just below the rim, depicts a unicorn running from right to left. Below this is a narrow band of scrolled decoration. Below this in the second main panel is stylised vine leaf decoration and part of the initial 'G'. Soda glass, clear. Virtually no weathering. Rim diameter 11.2 cm. Illustrated fig. 5.

SF 1558 3 fragments (joining) of rim and bowl of goblet. Rim is slightly inturned, bowl is convex and tapering. Decorated with diamond point engraving, possibly from the workshop of Jacob Verzelini. Two surviving panels of decoration. Top panel starts just below the rim, depicts a stylised tree on the left and the back legs of a running hoofed creature (a horse or unicorn) on the right. Below is a band of scrolled decoration and in the lower panel the remains of two out of a triangle of three initials, possibly D & P. Soda glass, clear. Very little weathering. Rim diameter 10.8 cm. Illustrated fig. 5.

SF 1559 1 fragment of bowl of goblet. Bowl is convex. Decorated with diamond point engraving. Engraved portion of hatched circle encompassing initial or number 'I' and the start of foliage decoration. Soda glass, clear. Very little weathering. Illustrated fig. 5.

SF 1560 1 fragment of bowl of goblet. Bowl is convex. Decorated with diamond point engraving. Lower band of scrolled decoration depicted with the date letters 85 above. Soda glass, clear. Very little weathering. Illustrated fig. 5.

SF 1560a 1 fragment of bowl from goblet. Bowl is convex. Decorated with diamond point engraved decoration. 1 band of three horizontal lines with an irregular rounded object above and angular one, possibly the top of the letter 't' below. Soda glass, clear. Very Little weathering. Illustrated fig. 5.

These six sets of fragments probably represent two very important goblets. The larger fragments of bowls are from two different vessels, based on the rim shape and the varying widths of banded decoration. It is most likely that the three small engraved fragments are also parts of one or both of these vessels. The ladder stem is of the

Figure 5- Verzelini Glass

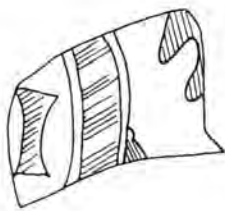
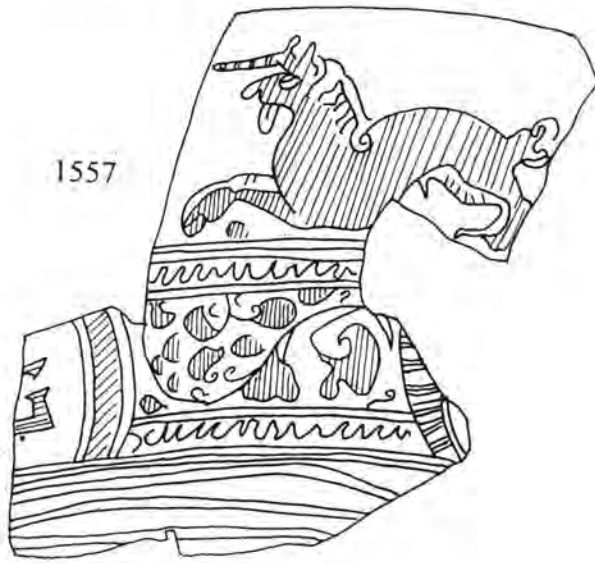

1559

1560a

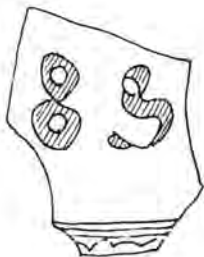

1560

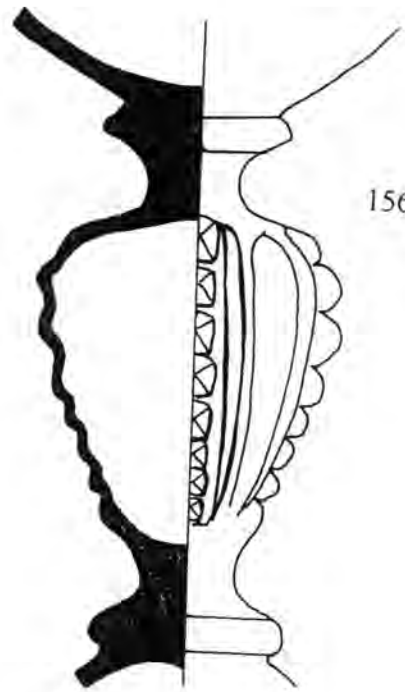

1565

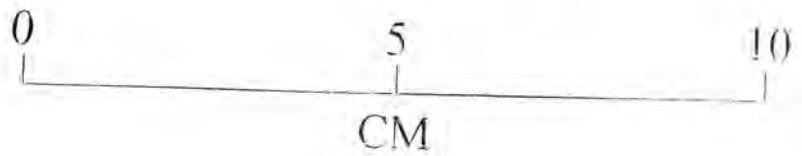

same metal as the two bowls, and a similar ladder stem appears on the engraved Winifred Geare glass, so it seems likely that what is represented are two fragmentary glasses directly attributable to Jacob Verzelini (Thorpe 1961: plate XVIa). The number of these vessels surviving is uncertain, in 1961 Thorpe identifies only five, although by 1984 Charleston recognises thirteen (Thorpe 1961: 105-108; Charleston 1984: 55-60). The actual number is certainly far higher today. These glasses must have been considered the best quality products to have come from Verzelini's workshop, the work required to produce such vessels being extensive. Indeed it is not surprising that these vessels were so respected that some have remained intact and cared for until the present day (Thorpe 1961: plate XVIa). The subject of the engraving, the hunt with horses, hounds and unicorns is a scene that appears on at least two other Verzelini glasses, the 'R.B.' glass and the Dier glass (Ibid.). Indeed it is this repetition of decorative themes that conclusively identifies these vessels as being the work of Verzelini. The presence of initials is a feature common to these glasses and the engraving on SF 1560 of the numbers '8 5' almost certainly suggest a date of manufacture of 1585, entirely consistent with when the other dated vessels of this type were produced.

When the pit group is considered as a whole it appears to contain a range of ordinary forest glass, medium quality soda goblets and the highest quality work of Verzelini. This contrast is probably explained by the incompleteness of all the vessels, that they were deposited when already very fragmented, and thus represent general disposal of material. The household that made this rubbish pit not only used ordinary forest wares but also could afford the best available in English glass as well. The date of the deposit is probably some time between 1585 and 1625 as there is no material later than this date included in this deposit.

The second deposit recovered from the area of trench 'E' was the fill of a rectangular stone lined pit. Amongst the debris were an assortment of oyster shells and animal bone as well as four glass vessels, suggesting that this again was probably

a cess pit subsequently filled with general domestic rubbish. This deposit however did produce vessel glass of a higher quality than the usual forest glass.

PIT 39

SF 1541 7 fragments (6 joining) of rim, shoulder and handle of jug. Rim wide and everted, tapering to a narrow short neck, widening. Decorated with two bands of applied blue trails, one on the edge of the rim, the other 8 cm below. Curving handle with thumb rest.

Soda glass, clear with grey tint. Cloudy weathering.

Rim diameter 12 cm. illustrated fig. 6.

SF 1542 2 fragments of rim and lower bowl of goblet. Rim upright, body convex. Decorated with one remaining mould blown vertical rib.

Soda glass, clear with slight grey tint. Little weathering.

Rim diameter 7.6 cm. Illustrated fig. 6.

SF 1543 Several joining fragments of rim and bowl of goblet. Rim slightly everted, bowl straight sided and trumpet shaped. Decorated with very feint mould blown wrythen decoration.

Soda glass, clear.

Rim diameter 7.2 cm. illustrated fig. 6.

SF 1546 1 fragment of rim and upper bowl of goblet. Rim slightly everted, bowl convex.

Soda glass, clear. Little weathering.

Rim diameter 6 cm. Illustrated fig. 6.

This pit produced four vessels, one jug and three goblets, all of soda glass. The jug is of a form and decoration that is suggestive of a Venetian origin (Charleston 1975: 208-210). Thin blue trailing was popular on Venetian glass in the fifteenth century and into the sixteenth century, and the form of this vessel suggests a date within the first quarter of the latter century (Charleston 1984: 19-22). It is likely that these goblets are of a similar period and origin, and these goblet forms are known from Venetian examples (Tait 1979: 72 fig.100) This group of glass therefore comes from an earlier period than the other pit, and seems to reflect the preference for Venetian glass in the early part of the sixteenth century, as opposed to English and Northern European wares in the latter part of that period. (The increased importation of Northern European wares is noted but not fully explored by Charleston 1984: 63-64). Given the history of the Venetian presence in Southampton in the early sixteenth century it is entirely possible that this earlier group was used by a Venetian merchant, although there is no other evidence for this.

Figure 6- Wachter Site 'E' pit 39 Glass.

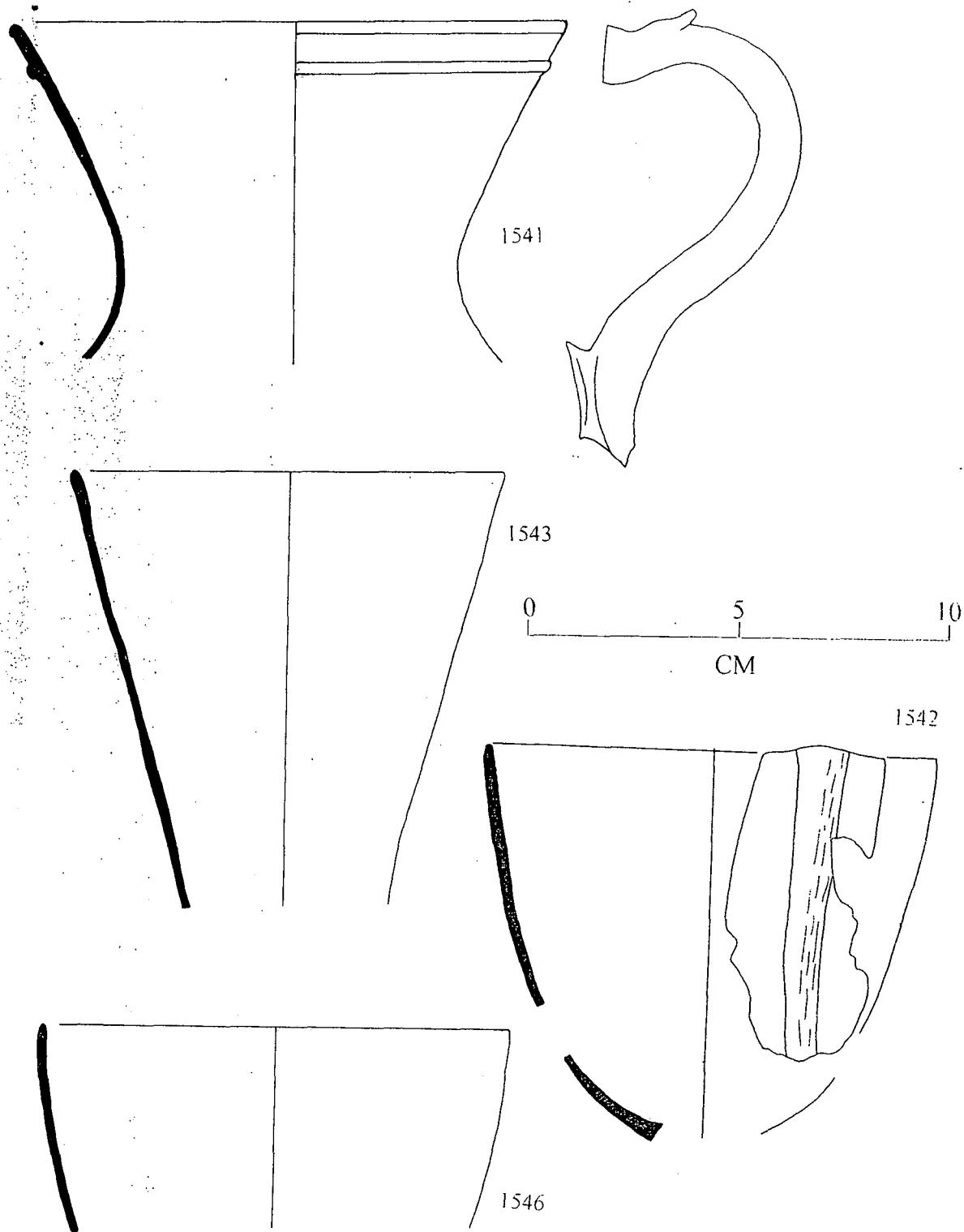

b) The High Street

Excavations on the High Street of Southampton were undertaken in the summers of 1967-69, in an area believed to have been occupied by some of the wealthiest merchants in the medieval and later periods. The excavations lay just to the north of the known house of Walter de Fleming, the most important merchant of his day in the fifteenth century, and was still occupied in the sixteenth century by the leading burgesses (Platt & Coleman-Smith 1975: 165). The excavations revealed the earlier building plans which, although modified in the sixteenth century, remained largely untouched. Glass was found in one pit, 209, this being a stone lined and vaulted structure. This pit related to Building 1 on the excavation, a substantial town house. The remains of eight vessels were recovered from this pit.

SF 1550 Fragments of rim, shoulder and top half of body of beaker. Rim upright, shoulder sharply incurved shoulder and convex body. Decorated with two applied pulled up prunts. Forest glass, green clear. Some weathering.
Rim diameter 6.4 cm. Illustrated fig. 8.

SF. 1553 1 fragment of rim and body of beaker. Rim upright, body slightly tapering and straight. Decorated with bands of opaque white, blue and red enamel in a stylised scroll or wriggle decoration. Soda glass, clear.
Rim diameter 7.6 cm. Illustrated fig. 8.

These two beakers are very different in both style and date. The first is a *Krautstrunk*, a popular form on the continent in the fifteenth and early sixteenth centuries, and sometimes occurs on English sites (Tait 1991: 153-155). Given the context for this vessel it is probably one of the later ones dating from the first half of the sixteenth century. The enamelled beaker on the other hand is probably Venetian and from the latter half of the sixteenth century, although Charleston suggests that this form of beaker might have been produced in England around 1600, after they ceased being produced in Venice (Charleston 1975: 212). However beakers are not the only vessel type to be found in this deposit.

SF 1552 1 fragment of body of goblet. Body is straight sided and of the trumpet variety, tapering to a thin point at the stem. Decorated with applied opaque white enamel blobbed decoration in vertical lines radiating from the lower body on mould blown vertical ribs. Soda glass, clear. Some weathering.
Illustrated fig. 8.

Figure 7-High Street Plan.

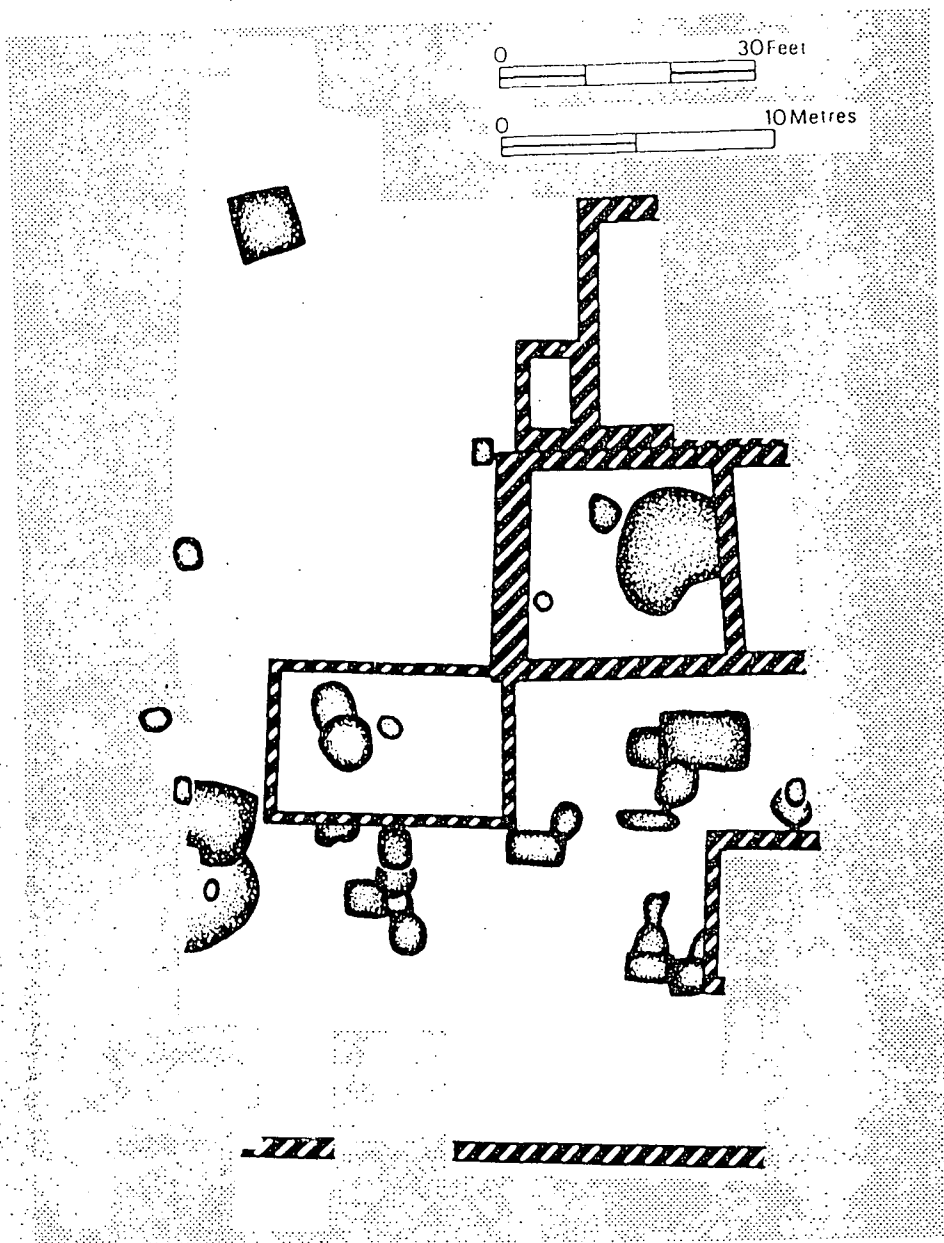

SF 1554 Fragments of rim, bowl and stem knob of a goblet. Rim is slightly everted, bowl concave trumpet shape. Decorated with mould blown decoration consisting of four rows of roundels and vertical fluting below. The knob is mould blown with a diamond pattern and traces of gilding. Below the knob is the start of a flaring base.

Soda glass. Clear, slight green tint. Little weathering.

Rim diameter 7.6 cm. Illustrated fig. 8.

SF 1556 1 fragment of base of goblet. Base is pushed in base with high kick that joins the outer surface, forming a small folded base ring. Decorated with mould blown spiral ribbing.

Soda glass, slight green tint.

Base diameter 9 cm. Illustrated fig. 8.

These three goblets appear all to be Venetian in style and are all from around the middle of the sixteenth century (Ibid.). The two bowls, SF 1552 and SF 1554, are highly decorated in the Venetian style, one with enamelling and the other with the gilding on the knob. It is possible that the base SF 1556 represents the lower portion of the enamelled goblet, but this is uncertain. These are high quality imported vessels, although this context does produce three vessels of a lesser quality, whose provenance is probably English.

SF 1547 Rim and neck of flask. Rim is vertical, with a slightly tapering neck. Decorated with faint mould blown vertical ribs starting 2 cm below the rim.

Forest glass, green/brown tint. Some weathering.

Rim diameter 3.2 cm. Illustrated fig. 8.

SF 1551 1 fragment of base of flask. Base is pushed in with a low kick. Not decorated.

Forest glass, green clear. Quite weathered.

Base diameter 6 cm. Illustrated fig. 8.

SF 1555 1 fragment of rim of urinal. Rim is horizontally everted with slight upturn on edge. Neck is vertical.

Forest glass, light green, clear. Quite heavily weathered.

Rim diameter 7.2 cm. Illustrated fig. 8.

These two flasks and the urinal are typical products of the sixteenth century in general, but can be dated by association with the other glass material to the middle of the sixteenth century. This dating is aided by the other associated material from this pit, Dutch brown glaze wares, Spanish micaceous wares and a goat of Henry VIII. This complements the glass all of which would not be out of place in this period. The *Krautstrunk* is possibly earlier but not deposited until this period (Henkes 1995: 65-67), but the beakers and goblets would fit happily into this chronology. This does indicate that Charleston's suggestion that the enamelled beaker is English and from

Figure 8- High Street Glass.

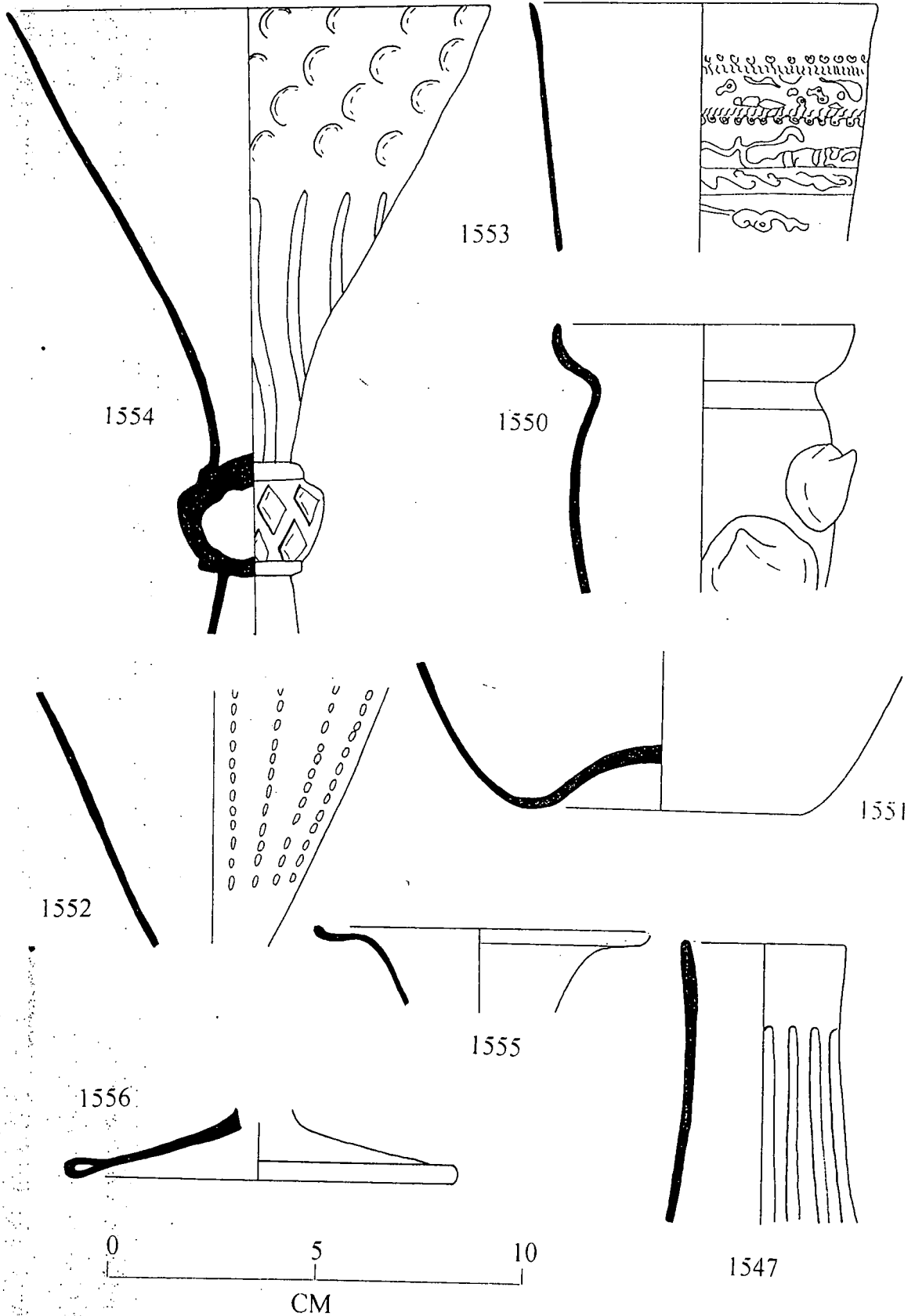

around 1600 is unfounded, and that it is indeed a Venetian product contemporary with the other vessels (Charleston 1975: 212).

Therefore the excavations carried out on the High Street have demonstrated the relationship between a known high status building and the deposits from it. The resultant material from the stone lined pit is from the middle of the sixteenth century and reflects the presence of imported quality wares from Venice and also the more ordinary wares from England or Northern Europe. Indeed the deposit dates from a period where the influence and quantity of Venetian trade is beginning to decline in Southampton and there is a shift to newer markets (Ruddock 1951, 206-232). Finding Venetian glass at this date might suggest that the owner of the house might have been him/herself a Venetian or possibly a merchant who traded with Northern Italy. Whoever the glass belonged to was obviously of a status that could afford fine imported glass at their table, as well as using more ordinary beakers and flasks.

c) Woollen Hall

Woollen Hall, although now destroyed, was once one of the most significant houses in Southampton (Platt & Coleman-Smith 1975: 111-112). It was originally early thirteenth century in construction and stood next to the western walls of the town, just south of the castle. The building plan was initially recorded shortly after bomb damage in 1944, (figure 9), and there have been subsequent excavations in 1962-66, although these have not been published (Ibid.). A large quantity of glass was recovered from the undercroft cellar of the building, but the nature of the site and its damage often means that contexts are confused and insecure. Woollen Hall, unlike the other sites investigated, produced a comparatively large quantity of forest glass, especially flasks, there being eleven in all.

SF 12 1 fragment of rim and neck of a flask. Rim is everted, neck vertical. No decoration.
Forest glass, quite heavily weathered.
Rim diameter 4 cm. Illustrated fig. 10.

Figure 9- Woollen Hall Plan

Ground Floor

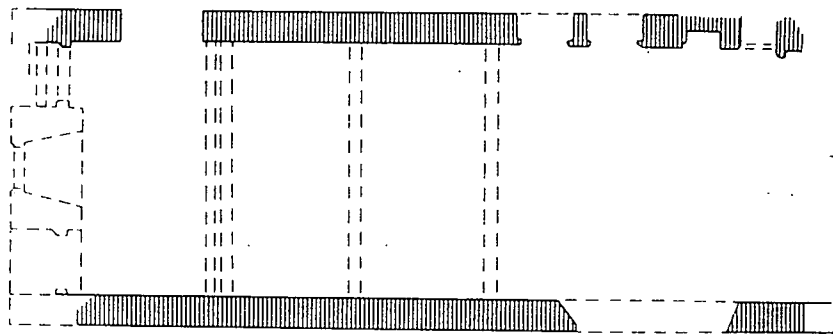

Undercroft

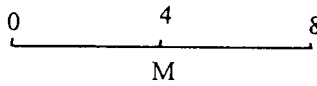
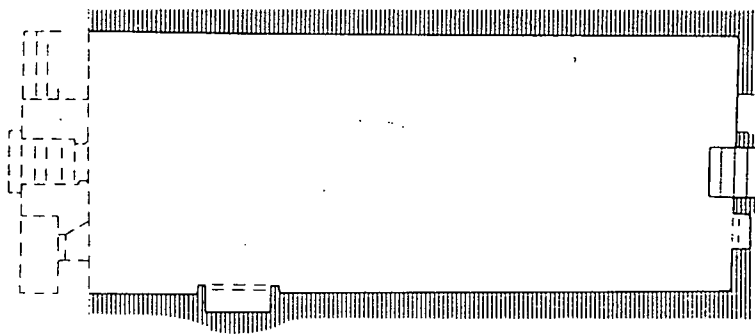

SF 7 1 large fragment of rim, neck and shoulder of oval bottle. Rim everted, neck vertical and shoulder convex. Decorated with mould blown wrythen decoration, from top right to bottom left, on neck and shoulder.

Forest glass, quite weathered.

Rim diameter 3.5 cm. Illustrated fig. 10.

SF 27 1 large fragment of base of flask. Base pushed in, with tall broad kick and pontil mark.

Forest glass, weathered.

Base diameter 7.3 cm. Illustrated fig. 10.

SF 30 2 fragments (joining) of a base ring of flask. Base ring is wide and folded from a pedestal base.

Forest glass, green clear. Weathered.

Base diameter 13 cm. Not illustrated.

SF 28 1 near complete base of flask. Base is pushed in with a medium kick. No decoration.

Forest glass, green. Weathered.

Base diameter 9 cm. Not illustrated.

SF 41 4 fragments (joining) of shoulder of flask. Shoulder is convex sided. Decorated with mould blown wrythen, running from top right to bottom left.

Forest glass, green. Weathered.

Diameter uncertain. Not illustrated.

SF 48 7 fragments of neck of flask. Neck is vertical. Decorated in mould blown wrythen, running from top right to bottom left. Forest glass, green. Weathered.

Not illustrated.

SF 31 1 large fragment of base. Base is pushed in flask with medium kick. No decoration.

Forest glass, green. Weathered.

Base diameter 11 cm. Not illustrated.

SF 37 1 fragment of rim and neck of flask. Rim slightly everted, vertical neck. No decoration.

Forest glass, green. Weathered.

Rim diameter 3.5 cm. Not illustrated.

SF 36 1 fragment of rim and neck of flask. Rim is slightly everted, neck is vertical. No decoration.

Forest glass, green. Weathered.

Rim diameter 4.5 cm. Not illustrated.

SF 38 1 fragment of rim, neck and shoulder of flask. Rim is slightly everted, neck vertical and shoulder convex. Not decorated.

Forest glass, green. Very weathered.

Rim diameter 6 cm. Not illustrated.

These eleven flasks all date from 1525-75, although a date in the earlier end of this range is possible due to the general unevenness and poorer quality of the metal (Charleston 1984: 30). All the flasks are of a similar form with the exception of SF 7 which is an oval bottle, (a very similar bottle has been uncovered from the wreck of the Mary Rose, but as yet remains unpublished; Elkerton A, Pers. Comm.), and SF 30 which is a pedestal flask. Three of the flasks are wrythen decorated, SF 7, SF 41 & SF 48, and this is a common feature on flasks of this type. They were almost certainly of

Figure 10- Woollen Hall Glass

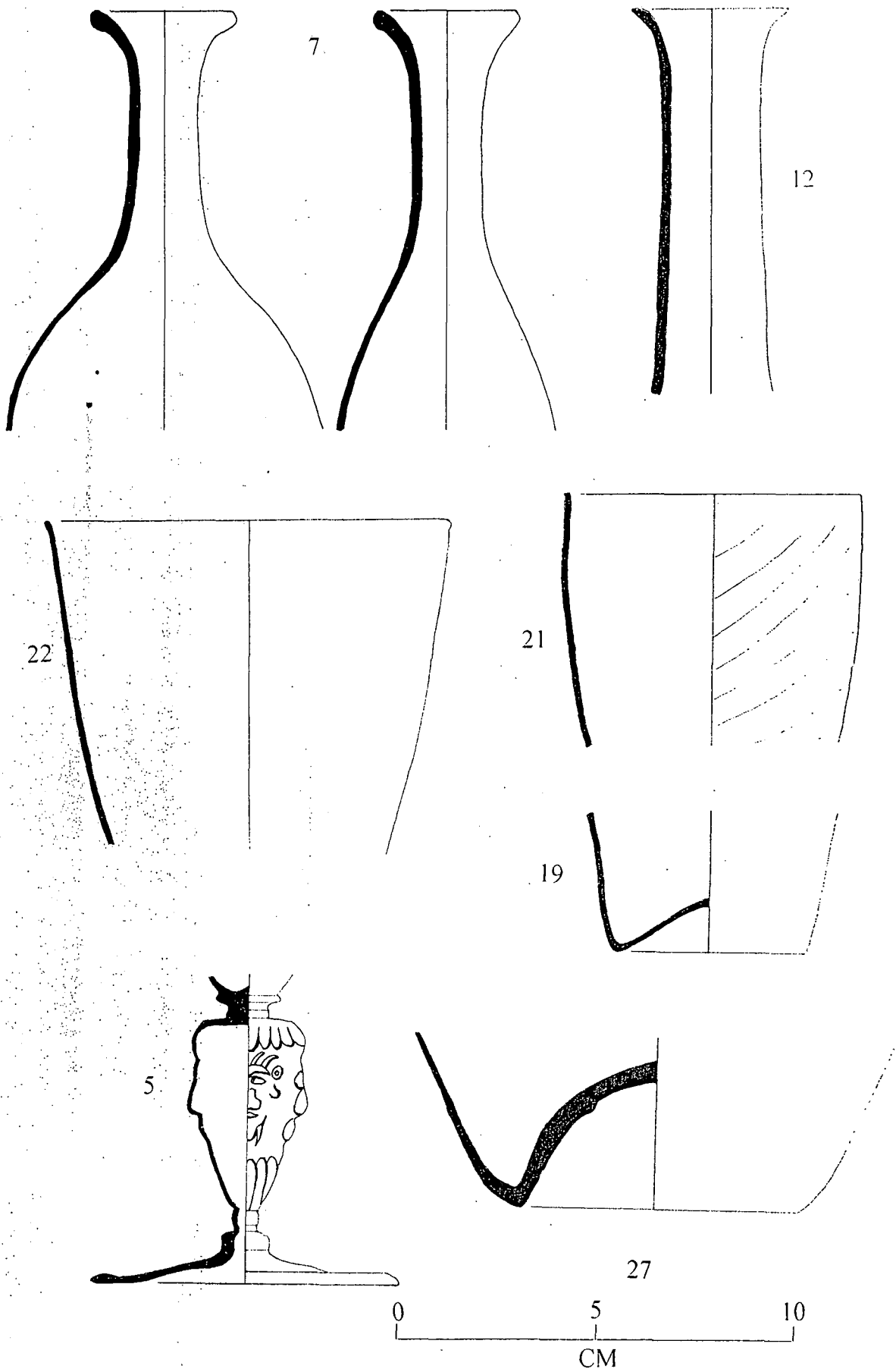

English manufacture, fragments of flasks are, after beakers, the most common find on English glass making sites (Charleston 1972: 144-145). Some of the larger flasks, SF 30 which is 13 cm base diameter and SF 31 which is 11 cm, suggest that this deposit might represent part of a group of glass associated with longer term storage. The location of the deposit in a cellar fill might confirm this as it might have been the original location for the storage of these flasks. If this is the case then this represents part of the storage contents of a wealthy mid-sixteenth century cellar. However Woollen Hall also produced evidence for other vessels, including three beakers.

SF 19 1 large fragment of base and lower body of beaker. Base is pushed in with a medium kick, body straight flaring. Not decorated.
Soda glass, clear. A little weathering.
Base diameter 5 cm. Illustrated fig. 10.

SF 21 1 large fragment of rim and upper body of beaker. Rim is slightly everted, the body convex and tapering. Decorated with mould blown wrythen decoration running from top right to bottom left. Forest glass, green. Quite weathered.
Rim diameter 7.2 cm. Illustrated fig. 10.

SF 33 1 fragment of a base of beaker. Base is pushed pedestal with high kick and folded base ring. Not decorated.
Forest glass, green. Weathered.
Base diameter 5 cm. Not illustrated.

Of the three beakers were found at Woollen Hall, two were of forest glass and one of soda glass. The soda beaker is possibly a very early sixteenth century Venetian '*moiolo*' (Charleston 1984: plate 10b) or more likely a later plain imported '*Gladde Beker*' from the Netherlands (van Dongen 1994: 10-11). As well as this soda beaker are fragments of two ordinary English pedestal beakers from the second half of the sixteenth century. All three vessels represent drinking vessels and were probably used almost exclusively for beer. Woollen Hall also produced evidence for one or two goblets as well.

SF 22 6 fragments (5 join) 5 rim and 1 bowl of goblet. Rim very slightly everted, bowl is curved and tapering. No decoration.
Soda glass, clear with slight grey tint. Little weathering.
Rim diameter 10 cm. Illustrated fig. 10.

SF 15 1 large fragment of stem and base of goblet. Base is broad and flaring with folded under base ring. Stem is a two piece mould blown lion mask stem, attached to lower bowl by a short extension and a flattened upper ring knob.

Soda glass, clear with a grey tint. Little weathering.

Base diameter 8 cm. Illustrated fig. 10.

Both these vessels are parts of soda goblets and are quite possibly the same vessel. They are possibly Venetian, but could equally be English or from the Netherlands as these forms are recognised from a variety of contexts with differing origins (Tait 1991: 156-166). These fragments date from the latter half of the sixteenth century and represent the quality of vessel that would be expected, although appears to be generally lacking, from a site of this status. It is possible that the deposits from the Woollen Hall undercroft only reflect the vessels that were stored there and that other vessels, along with other domestic waste were deposited elsewhere. The lion mask stem goblet is conspicuous in its quality amongst the rest of the deposit which is largely of ordinary forest glass.

d) St. Michael's House

St. Michael's House is situated along the waterfront due south of the castle, a prime location in the mercantile area. This section of the town was in the fifteenth and early sixteenth centuries part of the Venetian 'colony' which centred on the area of Galley's Key, figure 2 (Ruddock 1951: 70). The area was dug in 1972 with glass only coming from a single context, a stone lined pit B313. This pit was cut into the general fill of the cellar of the house and produced four almost complete vessels.

SF 601 6 large fragments, 1 neck and handle, 1 base and 3 body (all joining). Near complete profile of a small jug. Neck is vertical and upright, flaring towards the rim (lost). Body is convex 'onion shape'. Base is pushed in with a low kick. Handle is oval in cross section, curving around and in with a 'fish tail' end and a thin applied trail on the outer face of the handle. No decoration.

Soda glass with a grey tint. No weathering.

Base diameter 5 cm. Surviving height 12.5 cm. Illustrated fig. 11.

SF 604 7 fragments (all join) of rim, bowl and top of a stem of goblet. Rim inverted, bowl is straight sided trumpet shape, leading to a narrow central stem section. No decoration.

Soda glass with a grey tint. No weathering.

Rim diameter 9.8 cm. illustrated fig. 11.

Figure 11- St. Michael's House Glass.

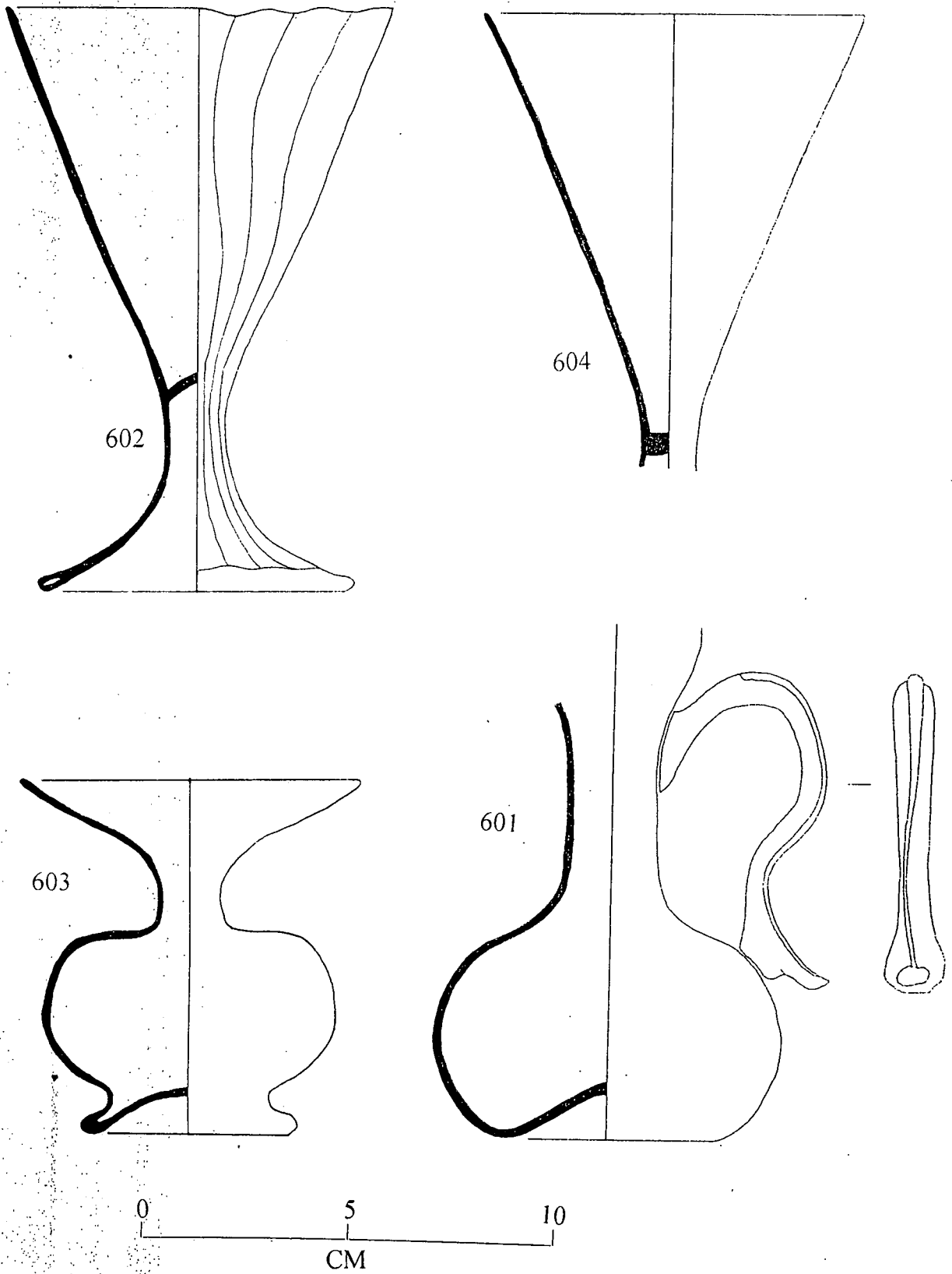

SF 602 5 large fragments, 1 base and 1 stem, 2 body and 2 rim of goblet. Rim everted, bowl straight trumpet, leading to a narrow stem. Base is pushed in with kick leading right up to the stem portion. Folded so that the kick joins the outer base, leaving a small base ring. Whole vessel decorated with mould blown twisted vertical ribbing.

Soda glass, very slight grey tint. No weathering.

Rim diameter 9.2 cm. Base diameter 7.3 cm. Height 14.1 cm. Illustrated fig. 11.

SF 603 15 fragments of a nearly complete ornamental jar or vase. Rim is wide and everted. Neck is short narrow and constricted. Neck joins a flattened convex shoulder and body. Base is pushed in with low kick and nearly folded over to produce a base ring.

Soda glass, opaque royal blue. No weathering.

Rim diameter 8.1 cm. Base diameter 4.8 cm. Height 8.7 cm. Illustrated fig. 11.

This deposit represents a small but very important group of Venetian glass. The completeness of the vessels might suggest that they were deposited whole in the pit and together as a group. The two goblets are of a standard Venetian form from the first quarter of the sixteenth century and are of a very high quality (Tait 1991: 72-73). Likewise the jug, although without exact parallel in England, is probably of the same origin and was used to hold and serve liquids at the table. The final vessel from this group is the most unusual and no similar example of a form such as this would seem to have been found in England. (None of the major authorities of glass from this period including, Thorpe 1961; Charleston 1984; or Tait 1991; identify such a vessel). It is highly unlikely to have a definite function at the table, the opaque blue glass and the form used suggests that it is an ornamental item. It has been suggested that a similar vessel in forest glass from the fifteenth century from Pontefract Priory is an ink stand (Tyson R, Pers. Comm.). However as a group of glass viewed together this deposit seems to represent the conscious clearing of a set, or partial set, of serviceable table glass, possibly illustrating a change in fashion. It might be possible to suggest that this clearing out occurred when the owner of the house, possibly a Venetian, moved out and a different occupier moved in. There is certainly no reason why this group of glass should have been disposed of unless through a change in fashion or taste.

Chapter 3- Winchester

Winchester, as a settlement, has had a long history of development, from the first century A.D. being the civitas capital Venta Belgarum, to the early medieval capital of the West Saxons. However after the conquest its importance as a national capital diminished, until by the sixteenth century it was no more than an important regional centre (Keene 1983: 3-7).

The glass examined from Winchester differs from that discussed at the other urban sites in that it comes from the suburb areas to the north and the east of the town as well as from the walled areas, figure 12. This glass is then contrasted with those vessels found from within the town walls in the Biddle excavations of the 1960s and 1970s which are already published (Biddle 1990: vol.1&2). The two suburbs of Victoria Road and St. John's Street produced small quantities of glass, which in the case of St. John's Street was quite heavily disturbed contextually.

a) Victoria Road

The remains of eight vessels from the sixteenth century were recovered from the site of Victoria Road; also the site of a late Roman cemetery. All of these vessels were of forest glass, with the exception of one soda fragment.

SF 3415 2 fragments, joining, of body of flask. Body is convex sided. No decoration.
Forest glass, green. Quite weathered.
Not illustrated.

SF 7261 1 small fragment of base of beaker. Base is pushed in with medium kick. No decoration. Forest glass, green. Weathered.
Base diameter uncertain. Not illustrated.

SF 3890 1 fragment of base of small bottle. Base is pushed in with medium kick and square pontil mark. No Decoration.
Forest glass, green. Weathered.
Base diameter 3 cm, pontil 1.1 x 1.1 cm. Not illustrated.

SF 4870 1 small fragment of base of beaker or flask. Base is pushed in with low kick. No decoration.
Forest glass. Heavily weathered.
Base diameter uncertain. Not illustrated.

These four fragmentary vessels are typical forest glass products from the sixteenth century. The contexts of the first two vessels are very insecure with the latter coming

Figure 12- Winchester Site Locations.

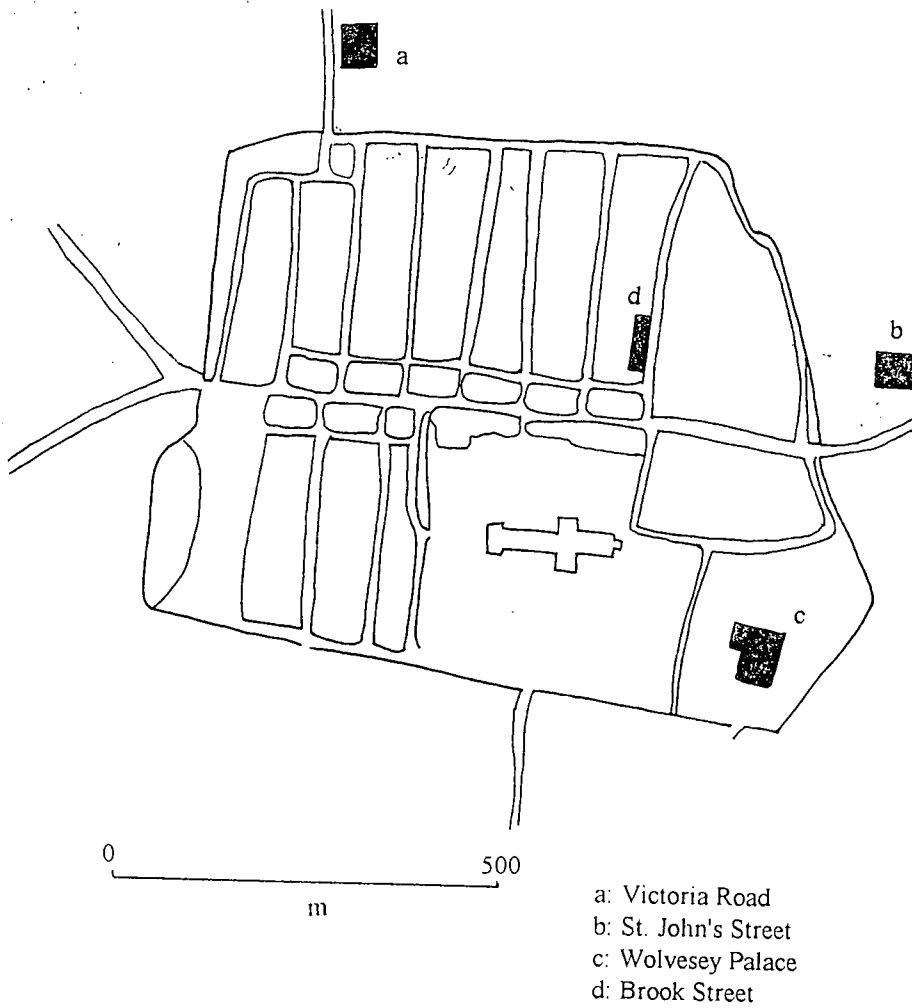

from an eighteenth century feature. The third is from an early sixteenth century pit which contained other domestic rubbish, such as animal bone. The next three fragments from this site, although being made of forest glass, are more unusual.

SF 5179 1 fragment of base of case bottle. Base is flat with a distinct cracked off circular pontil mark. Forest glass, green. Quite weathered.
Pontil diameter 1.75 cm. Not illustrated.

SF 3687 1 large fragment of base of case bottle. Base is flat with a distinct cracked off circular pontil mark. Forest glass, green. Heavily weathered.
Pontil diameter 2.2 cm. Illustrated fig. 13.

SF 6124 1 large fragment of base of case bottle. Base is flat with a distinct cracked off circular pontil mark. Forest glass, green. Heavily weathered.
Pontil diameter 2 cm. illustrated fig. 13.

These three fragments all come from the same type of bottle, a large square flask or case bottle. These vessels became common and popular in the seventeenth century and it has been suggested that their origin was in the previous century (Charleston 1984: 91-92). The earlier vessels are assumed to be small, primarily because examples found on the glass production sites of Hutton and Rosedale dating from the end of the sixteenth century, were as small as 14 cm high (Charleston 1972: 145, no. 48). Charleston asserts that these were all blown into a fixed mould (Charleston 1984: 91-92) but these examples and another near complete case bottle from Colchester suggests that some of the earlier vessels were blown in the round, attached to a pontil on the base and flattened. (This vessel is discussed fully in chapter six). It could be that the pontil mark is the result of applying a pontil iron after the vessel was drawn out of the mould for the purpose of forming the rim. However the base is not flattened, being slightly pushed in, nor does it have any features consistent with a base that has been formed by blowing into a fixed mould. A possible explanation of these pontil marks is that smaller square case bottles in the sixteenth century were indeed blown into moulds, whilst larger examples were hand blown in the round and then flattened on the marver block, a procedure that is replaced by the use of larger moulds in the seventeenth century. Two out of the three fragments from Victoria Road, SF 5179 & SF 3687 came from late medieval contexts, the other, SF 6124, from a medieval one, but this could well be from a disturbed context.

A possible alternative has been suggested by Hilary Cool, that these fragments actually represented the central 'bull's eye' of crown window glass (Cool forthcoming). When this form of glass is made the central portion, where the pontil joins the newly formed glass sheet, is formed which is thicker than the window glass to be used (Charleston 1984: 38-39). However this portion of glass was not often used in windows of this period and presumably either was re-melted or discarded on the production site, so unless there was a window glass production site at Victoria Road, these fragments are more likely to represent bottle bases. Only one fragment of soda glass was found on the site, although this unfortunately comes from an unstratified context.

SF 3909 1 fragment of bowl of goblet. Bowl is convex sided. Decorated with three bands of opaque white decoration and one band of twisted *lattimo* threading.
Soda glass, clear. Quite heavily weathered.
Illustrated fig. 13.

This one fragment comes from a good quality goblet, probably from the end of the sixteenth century. The decoration is typical of Venetian products of the period and it is a fragment of a high quality vessel (Tait 1991: 168; Tait 1979: 73).

The Victoria Road group of glass is interesting for several reasons. Of the eight vessels recovered, seven were of potash glass, these being three flasks, one beaker and three case bottles. This is a high percentage of storage and serving vessels, with a lower than normal representation of drinking receptacles. The unusual nature of the case bottles has already been discussed, and they are important in their own right. The presence of the soda glass goblet fragment, which is without a context, is an indication that some quality vessels were being used in this area, but without further examples it is hard to say to what degree. This possibly indicate that glass was used for the serving or storing of liquids, but not for consuming them on this site.

b) St. John's Street

St. John's Street is a similar suburb to that of Victoria Road, although the archaeology was a lot more disturbed by subsequent activity, leaving many of the

Figure 13- Victoria Road & St. John's Street Glass.

Victoria Road

6124



3687



3909

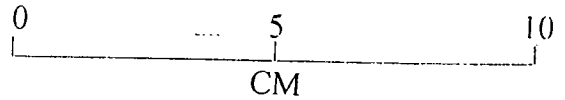
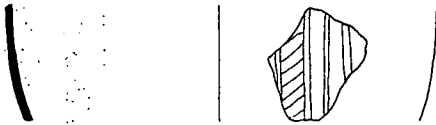

St. John's Street

2114-15

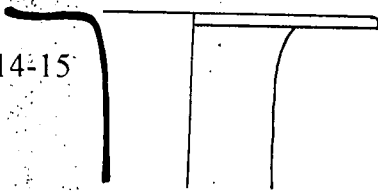

714



478

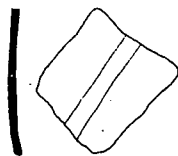

glass fragments in incorrect contexts. Of the ten identified vessels only two came from secure features of the sixteenth century, the rest relating to eighteenth century or later contexts. However the glass is still an important indication of what activity, in terms of material culture, was occurring on the site.

SF 750 1 large fragment of base of flask. Base is pushed in with a medium kick. No decoration. Forest glass, green. Weathered.
Base diameter 8 cm. Not illustrated.

SF 475 1 fragment of neck of flask. Neck has a thick top section with slight start of rim present. No decoration. Forest glass, green. Weathered.
Not illustrated.

These two fragments are of typical English forest flasks (Charleston 1972: 131-135). The base SF 750 is from an early sixteenth century context, whilst SF 475 is residual material in an eighteenth century one. This second flask could be from virtually any part of the sixteenth century, such is the uniformity of their design.

SF 2114-15 & 222 Four fragments, 3 rim and 1 neck, of urinal. Rim is everted with slight up turn on the edge. Neck is thin and vertical. No decoration. Forest glass, green. Heavy weathering.
Rim diameter 7.5 cm. Illustrated fig. 13.

SF 714 1 large fragment of base of a urinal. Base is convex and thick with an external pontil mark. No decoration. Forest glass, green. Weathered.
Illustrated fig. 13.

SF 319 1 large fragment of base of urinal. Base is convex and thick with an external pontil mark. No decoration. Forest glass, green. Weathered.
Not illustrated.

These three urinals are characteristic of the sixteenth century form, although it is possible that they might date from the fifteenth century (Charleston 1984: 32-33). They demonstrate the typical remains of this type of vessel usually with the thick convex bases and the everted rims with a slight lip. The central portion, because it is blown to extreme thinness, rarely survives. All three of these urinals were found in eighteenth century contexts, although they could not possibly date from this later period (Ibid.).

SF 211 2 fragments of body of beaker. Body is vertical and convex. Decorated with faint mould blown diamond pattern. Forest glass, green. Weathered.
Internal diameter 7.5 cm. Not illustrated.

SF 238 6 fragments of body of beaker. Body is vertical and convex. Decorated with faint mould blown diamond pattern.

Forest glass, green. Weathered.

Not illustrated.

SF 221 1 fragment of body of beaker. Body is vertical and convex. Decorated with faint mould blown diamond pattern.

Forest glass, green. Weathered.

Not illustrated.

These three groups of beaker fragments are probably all from the same vessel, although the weathering prevents any from being joined. They all come from the same context and have the same form of decoration. Although the size of the diamonds does vary this would also happen on different parts of the same vessel. This is an English made beaker from the second half of the sixteenth century, or possibly the first quarter of the seventeenth century despite being from an eighteenth century context (Charleston 1972: 136-140).

SF 464 1 small fragment of body of beaker. Body is vertical and convex. Decorated with a faint indeterminate mould blown decoration.

Forest glass, green. Weathered.

Not illustrated.

This is a very similar beaker to the previous one, but from an early sixteenth century context, although it is a form from the latter half of that century. However St. John's Street does have one fragment of a soda glass vessel.

SF 478 1 fragment of bowl of goblet. Body is vertical and convex. Decorated with a single marvered opaque white trail.

Soda glass, clear. Little weathering.

Illustrated fig. 13.

This is a very small fragment of a soda vessel, probably from a goblet but possibly from a beaker. It is too small to tell its origin for certain, but a Venetian or Low Country source is most likely (Henkes 1994: 173-178). This is a better quality drinking vessel, although the fragment is too small to determine its form. However it does suggest that there was some limited use of higher status vessels.

The St. John's Street assemblage is a typical group of forest glass, with all three major forms of potash glass being represented. Two flasks, three urinals and two beakers is a standard pattern from sixteenth century sites. However the lack of soda glass, limited to only one small fragment, suggests that the use of quality vessels was

not widespread. This could indicate that the suburb in this area was not as affluent as the central city in the late medieval period.

The glass from both these sites shows that the suburbs as a whole are not using a large quantities of vessels, especially of a higher quality. However if a balanced picture is to be achieved it is important to compare this material with objects excavated within the town walls. The two sites that have produced the most glass from this period, from the centre of the town, were both from excavations by Martin Biddle, these being Wolvesey Palace and Brook Street (Biddle 1990: 934-947). Although both these sites did not produce a large quantity of glass between them, only twelve vessels in total, it provides a contrast between sites which are inside the town walls and those which are not.

c) Wolvesey Palace

Wolvesey Palace was the largest area to be excavated within the limits of the town walls. It was the residence of the Bishops of Winchester from the twelfth century onwards and went through a number of successive rebuildings and improvements (Biddle 1990: 1204-1206). The final plan was consolidated in the late thirteenth century and latterly only received minor modifications. Indeed by the seventeenth century there seems to have been very little activity on the site and in the 1660s a new house was build beside it, to replace it (op. cit.). The palace was then left largely to decay. Its final plan from Biddle's report is shown on figure 14, where the rooms where glass was found are indicated. It is important to note that very little glass was found and this is discussed at the end of this section.

SF 3304 2 fragments of base of flask or jug. Base has a folded foot ring from a pushed up base. Decorated by marvered *lattimo* twisted threads.

Soda glass, clear.

Base diameter 8 cm. Illustrated fig. 15.

SF 3312a 1 fragment of rim and neck of flask. Rim is everted and Neck is vertical. Decorated on neck by mould blown wrythen decoration.

Forest glass, heavy weathering.

Rim diameter 2.8 cm. Not illustrated.

Figure 14- Wolvesey Palace Plan.

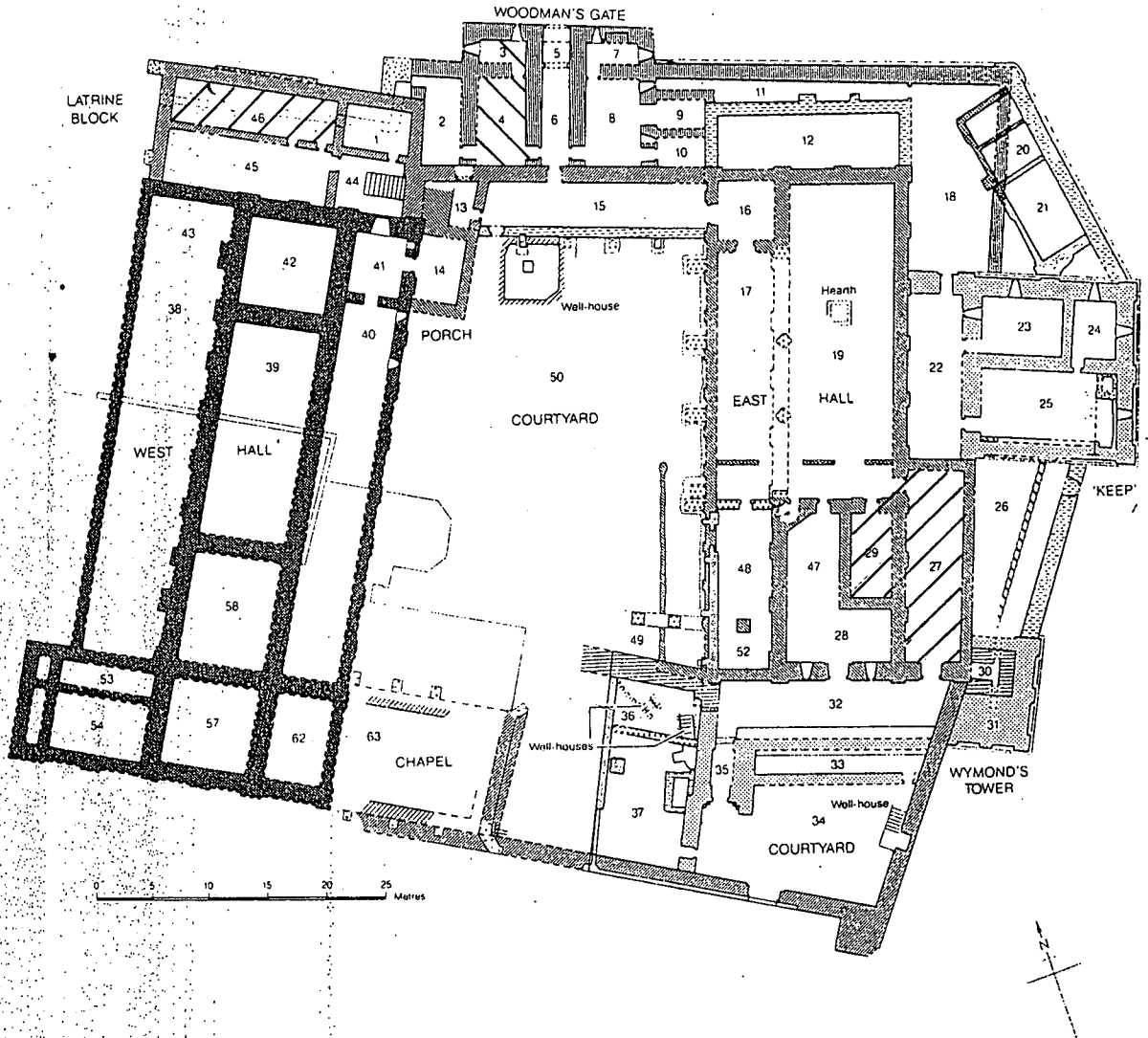

These two flasks, or a jug and a flask, are the only two vessels of this category from the site and they are very different from each other. The first, SF 3304, is an imported vessel, most probably from Venice (Charleston 1990: 943). The *lattimo* decoration, which consists of alternating plain and twisted bands of opaque white glass, is known on vessels found at a number of sites in England, with a complete vessel of a jug form with an identical base being in the Museum of London (Hume 1962: fig. 6). Such an item is a luxury piece, not out of fitting with the palace environment it was found in and dates from the second half on the sixteenth century (Ibid; Charleston 1990: 943). The second flask; SF 3312a, is of the much more common type found on most sites of any status (Thorpe, 1961, p.83-84). These are the only two flasks from the site and they provide the sharp contrast that exists between the soda and forest glass within the same broad form.

SF 3309a Several fragments of base of beaker. Base is pushed with folded base ring. No decoration. Forest glass, green clear. Medium weathering. Base diameter uncertain. Not illustrated.

This is the only fragment of a beaker found on the site and it is of the commonly found forest variety (Charleston 1972: 148 fig. 66). It is surprising that there are no more fragments of these vessels were found since they were the most common type of glass drinking vessel. However this might be explained by the generally low number of vessel fragments found on this site, which is discussed later.

SF 3300 1 fragment of lower bowl of goblet. Bowl is convex. Decorated with the remains of three mould blown ribs. Soda glass, clear. Illustrated fig. 15.

SF 3321 1 fragment of lower bowl of goblet. Bowl is convex. Decorated with marvered opaque white trails in a feathered combed pattern. Soda glass, dark blue. Illustrated fig. 16.

The site produced small fragments of two goblets, both of them were in soda glass and were imported vessels. Both are almost certainly Venetian and from the second half of the sixteenth century (Charleston 1990: 942). The first goblet, SF 3300, is of exactly the same form as the one from Site 'E', pit 39 at Southampton (chapter 2, figure 6, SF 1542) and of plain glass, decorated only by mould blown vertical ribs.

Figure 15- Wolvesey Palace Glass.

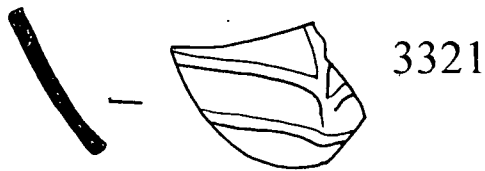
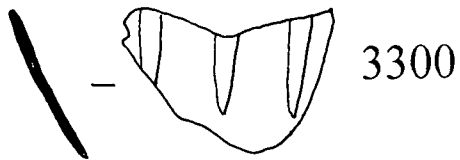

The second goblet, SF 3321, is of a less common type and without exact parallel. Similar vessel decoration occurs later in the seventeenth century on flasks, but this is against a red/brown background colour (Charleston 1975: 225-226). It is likely, given the fact that the palace went into general decay at the end of the sixteenth century, that this fragment is an earlier form. Both vessels are of a very high quality and consequently are likely to be high status items.

Wolvesey Palace only produced evidence for five vessels, three of which were of soda glass. This surprisingly small quantity of glass might be explained by the nature of the site. All the glass was found within the building itself and assuming that such a structure would have been kept fairly clean, it is not unusual that little glass was recovered. It would be much more likely to find the glass deposited outside in associated pit contexts. Figure 14 shows the location of the glass within the palace buildings. The spread of fragments is quite general over the site, but three of the five fragments, within a context, are in ante-rooms associated with the east hall, rooms 27 and 29. These are the *lattimo* flask, SF 3304, the forest beaker, SF 3309, and the clear soda goblet SF 3300. The two other fragments, the forest flask, SF 3312a and the blue glass goblet SF 3321 come from the latrine block and the Woodman's Gate respectively.

d) Brook Street

A large area was excavated along the west side of Lower Brook Street, exposing the remains of several houses and two churches, St. Mary's and St. Pancras's, figure 16. In the late medieval phases glass was found in the areas associated with the final phases of both these churches and house IX/X. This house displayed quite a wealth of occupational debris, especially fine metal work (Biddle 1990: 1162-1165). The distribution of the glass amongst the areas of this site is discussed at the end of this section.

Figure 16- Brook Street Plan.

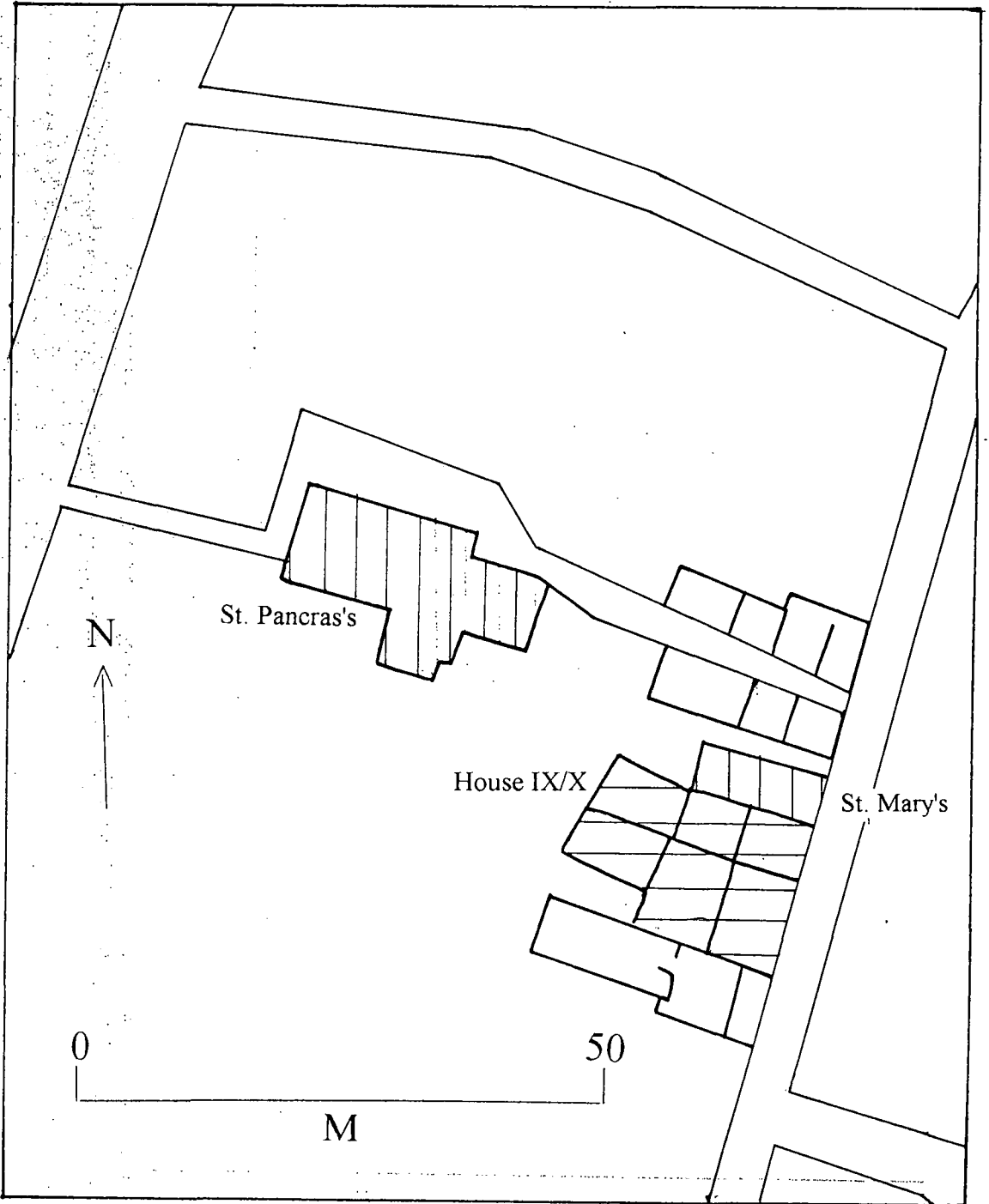

SF 3315 Fragments of base of flask or bottle. Base is pushed in with high kick and remains of a pontil mark. No decoration.

Forest glass, green clear. Weathered

Base diameter uncertain. Illustrated fig 17.

This is the only flask or bottle fragment and despite coming from a nineteenth century context is probably late sixteenth or early seventeenth century.

SF 3320 1 fragment of rim and body of beaker. Rim is slightly inturned and body convex. No decoration. Soda glass, blue.

Rim diameter 7.5 cm. Illustrated fig. 17.

Like Wolvesey Palace, Brook Street only has one fragment of a beaker, an unusual proportion. This is an uncommon vessel; Charleston suggests that it is of the form of a German stoneware tankard, with a cylindrical neck and globular body (Charleston 1990: 945). There are known *lattimo* vessels of this form, but one in plain blue glass is without parallel in England. It is almost certainly a Venetian vessel and by its form would date to the second half of the sixteenth century (op. cit.).

SF 3301 1 fragment of base of goblet. Base fragment is from upper pedestal of a goblet. Fragment from the junction between the foot and the stem. No decoration.

Forest glass, brown clear.

Not illustrated.

SF 3309b 1 fragment of base of goblet. Base is pushed in with folded base ring. No decoration. Forest glass, green clear.

Base diameter 7 cm. Illustrated fig. 17.

SF 3299 1 fragment of base of goblet. Base is flaring with folded under base ring. No decoration. Soda glass, clear.

Base diameter 7 cm. Illustrated fig. 17.

These three fragments of goblet are all of a similar form, although in different types and styles of glass. The first two, SF 3301 and SF 3309b, are both pedestal goblets, a type known from the glass production sites of Hutton and Rosedale in Yorkshire (Charleston 1972: 149, fig. 6). The first example is clearly of forest glass and the second probably is as well, although better preserved. The third example, SF 3299, varies in that its base is not formed by the pushing in of the bubble of glass, rather it was worked as a separate piece and was added while still hot to an already formed stem. As to the form that this vessel took it is impossible to tell, but this is a fragment of a better quality soda goblet and in terms of complexity it took longer to

Figure 17- Brook Street Glass

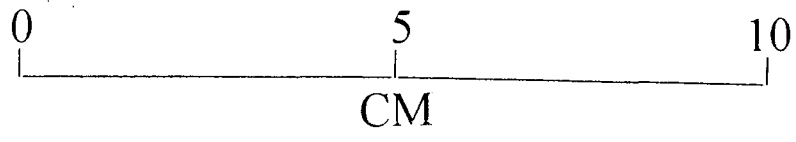
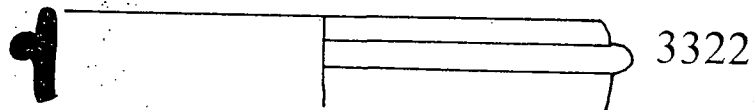
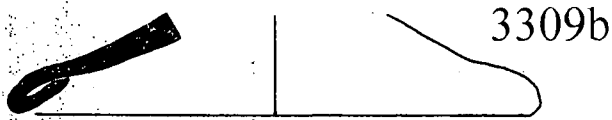
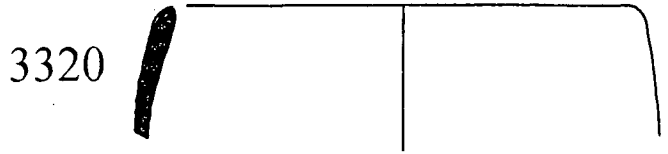
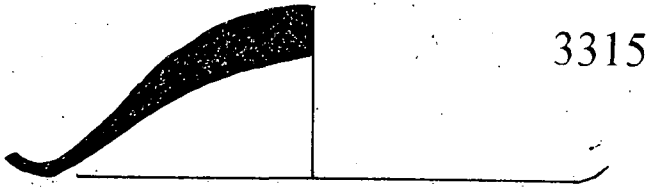

manufacture and was more elaborate. The final fragment from Brook Street is completely different and of an uncertain form.

SF 3322 1 fragment of lid? Fragment is slightly inturned with a curving convex body. Decorated with one thick applied trail below the rim.

Soda glass, purple.

Rim diameter 6.5 cm. Illustrated fig. 17.

This is a curious fragment of a vessel which is of indeterminate form. Charleston suggests that this is drinking vessel or a jug, but the heavy applied trail just below the rim would make drinking or pouring out of this vessel rather hard (Charleston 1990: 946). It might belong to a decorative vase or other such vessel, although if the fragment is inverted it could function as a lid. This is improbable, as all other known lids have a folded ring instead of an applied thick trail, but it would be serviceable as such (Tait 1979: 73 plate 102; Harden 1977: 210-211).

The distribution between the two churches and house IX/X is interesting. The two imported soda vessels, the plain goblet, SF 3299, and the plain blue beaker, SF 3320, both come from the house, which from the quality and quantity of other small finds suggests is of quite a high status (Biddle 1990: 1162-1165). St. Mary's Church, next door to the house, has only the one vessel, the forest glass goblet, SF 3309b, whilst St. Pancras's has a similar goblet, SF 3301 and a forest flask, SF 3315. Unfortunately the unusual purple vessel fragment is unstratified. There appears to be a differentiation between the soda glass of the house and the forest glass of the churches, although the vessel fragments are too few to say for certain.

The material from Winchester has been examined from two general zones, that glass from the suburb areas and that from the walled centre. The vessel glass from the suburbs was limited and only two fragments of imported soda wares were found amongst the general make up of forest glass. In comparison the material from Wolvesey Palace and Brook Street contained a higher proportion of these better quality wares. Whether this is an indication that the inner town was more wealthy than the outer town or had more access to these better products is unclear. It is an obvious anomaly that the quantity of glass from Winchester as a whole is very low when

compared to near by Southampton. However there does appear to be a link with Southampton, in that the imported soda wares found were almost certainly all from Venice, with an apparent lack of Northern European quality wares. This could suggest that the glass being imported into Southampton was then making its way to Winchester, probably both for use and further regional distribution. The differential amounts of glass found at these two sites could be the result of several factors. It could be that little glass was actually used in Winchester, rather it moved straight through or was distributed to out side the town. However this does not explain the lack of home produced forest glass on sites in Winchester. It is more likely that the nature of the archaeological excavations was partly a factor in the quantity of glass recovered, with either the glass not being recognised for what it was, or the lack of emphasis on that glass which was not exotic soda glass in the published report.

Chapter 4- Oxford

Oxford became established in the late Saxon period as a large town, being a fortified burgh and much of its subsequent development has respected these early street plans and land divisions. By the late middle ages Oxford occupied a prominent position in the region, remaining important with the founding and development of its university. By the sixteenth century it still maintained its significance as a centre, this being enhanced in the early seventeenth century when Oxford, for a time, became the centre for Royalist power in the Civil War (Hassall 1984: 155-156).

The glass examined from Oxford came mainly from two excavations, the first was a row of tenements in Church Street in the Greyfriars area in the south west of the walled town, and the second from along the main High Street. Both these groups of glass come from pit deposits which can be related to individual houses, and even tentatively to certain documented people. Both date from the end of the sixteenth century and give the impression that in this period, on both sites, quantities of glass were being used and disposed of.

a) 31-34 Church Street

The excavations on Church Street revealed the remains of four frontages of buildings and a significant part of their yards behind, figure 19. (Hassall 1984: 161). The structures found started in the very early fifteenth century and continued along the same boundary lines to the present day. In the sixteenth century only two buildings were found to be consolidated in stone, numbers 31 and 34, although the other building plots were probably used as gardens. Glass was recovered from pit contexts from the sixteenth to the nineteenth centuries, but two groups in particular fall into the period of study of this thesis. Both these pits were related to the plot of number 32 Church Street; the garden of the house at number 31 or 34, and are

Figure 18- Oxford Site Locations.

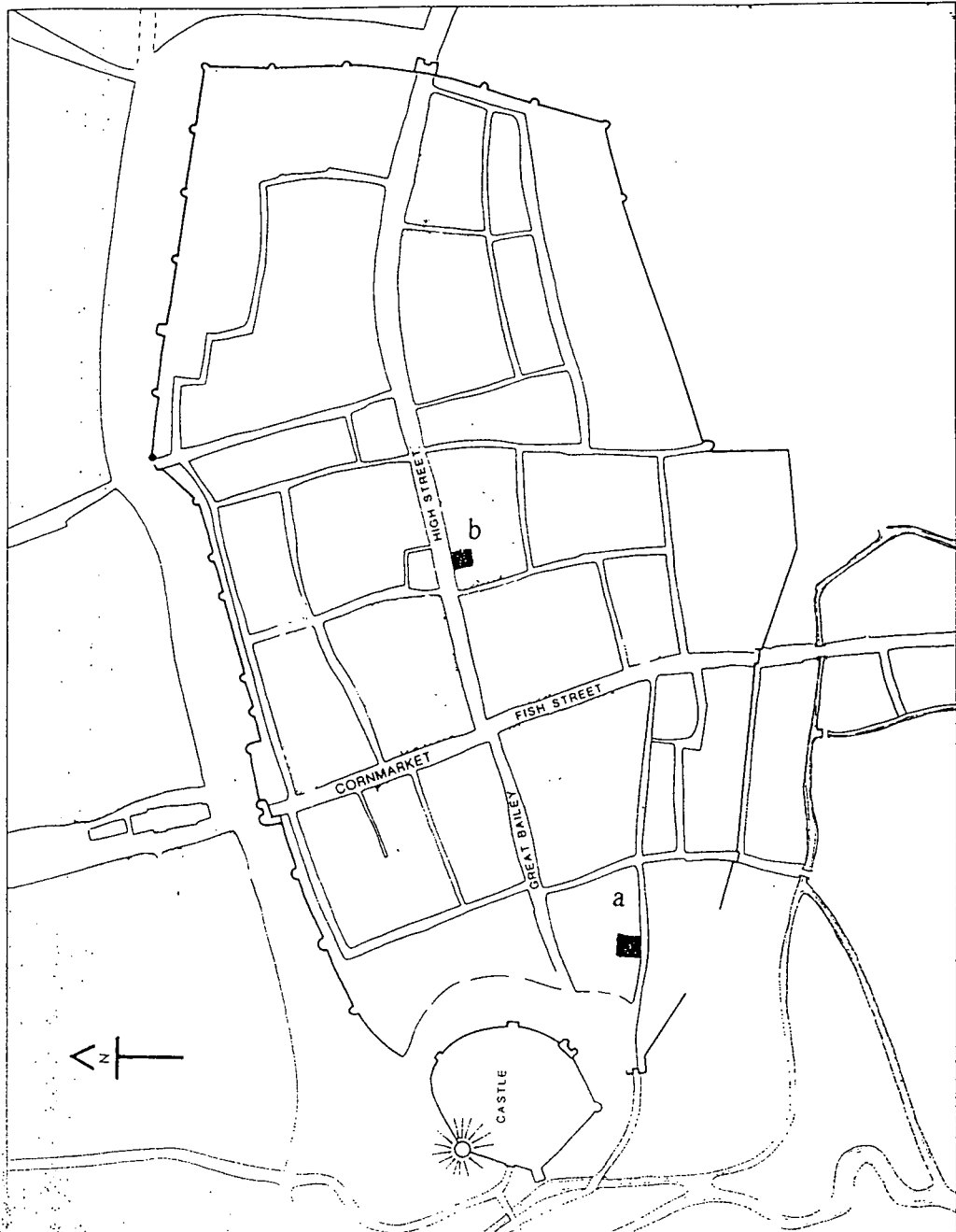

a: Church Street b: High Street

Figure 19- Church Street Plan.

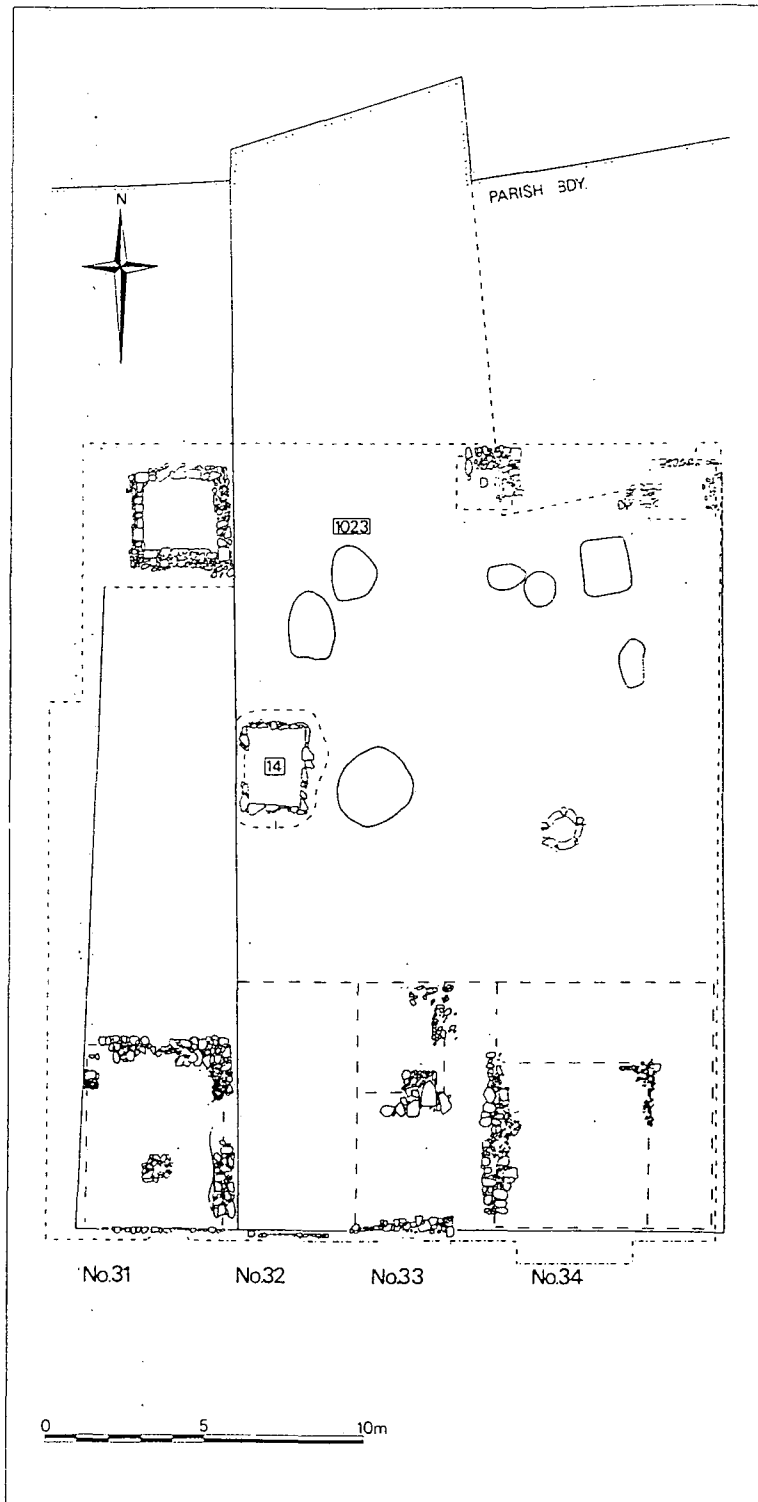

from different periods of the sixteenth century. The earliest pit feature, 14 on the figure, was stone lined and contained three glass vessels (op. cit.).

PIT 14

SF 1 1 large fragment of base of beaker. Base is pushed in pedestal with folded base ring. Not decorated. Forest glass, green clear. Some weathering.

Base diameter 7 cm. Not illustrated.

SF 2 1 complete base of goblet. Base is flaring with folded under edge. Joins the stem with a small rounded lower knop. Not decorated.

Soda glass, clear. Little weathering.

Base diameter 8 cm. Illustrated fig. 20.

SF 3 1 fragment of base of case bottle. Base is pushed in with a slight kick. Not decorated.

Forest glass, green. Some weathering.

Base 8 cm x 8 cm. Not illustrated

These three vessels are a late sixteenth century group. The forest beaker, SF 1, is of a typical form for this period and a common drinking vessel (Charleston 1984: 88). The base of the goblet is of a variety not often seen in the sixteenth century. Instead of being a pushed in pedestal type, it is made as a separate piece, with the base edge folded under, and then applied to the stem. It is just possible that this base is part of a cigar stem goblet, a popular form in the first quarter of the seventeenth century, although this seems too early a context in which to find such a vessel (Ibid. 68). The final vessel, SF 3, is from a late sixteenth century case bottle of the type found at the Hutton and Woodchester glass houses (Charleston 1972: 145 fig. 63). This again dates from the last quarter of the sixteenth century.

This pit group is typical of the various elements of glass that operated in a dining context. The case bottle was used to fill serving jugs at the table, whilst the goblet was used to consume the wine (van Dongen 1994: 8-9). The beaker was the most popular drinking vessel of all, used to consume mainly beer with all meals; water being considered unfit for drinking (op. cit. 10). These examples appear to have been deposited in one action into this pit, possibly the result of a clearing out of an old set of vessels.

The second pit, 1023, from this period is of a similar date and contains a matching array of glass vessels. It was cut into the same tenement plot about five

Figure 20- Church Street Glass.

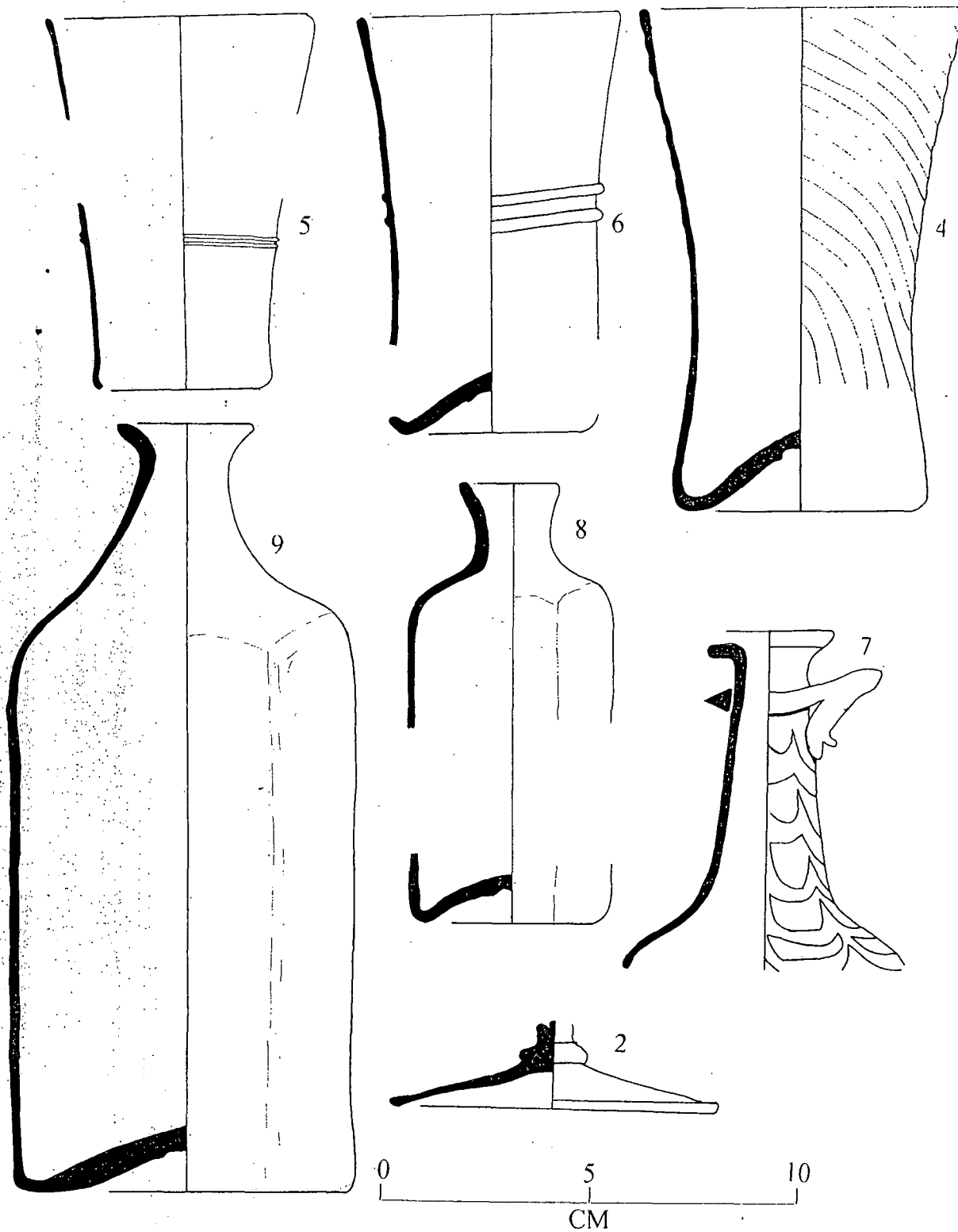

metres north of pit 14, possibly in the first few years of the seventeenth century, although the material it contains was probably several years old on deposition.

SF 4 5 fragments of rim, body and base, giving a full profile, of beaker. Rim is slightly everted, body concave and base pushed in with the remains of a pontil mark. Decorated with mould blown wrythen decoration, running from top left to bottom right.

Forest glass, green clear. No weathering.

Rim diameter 7.3 cm. Base diameter 6 cm. Illustrated fig. 20.

SF 5 1 fragment of base and 1 of rim, of beaker. Rim is slightly everted, body slightly concave and the base is pushed in (kick is missing). Decorated with a single applied trail running horizontally 3.2 cm above the base.

Forest glass, green clear. No weathering.

Rim diameter 6 cm. Base diameter 4.5 cm. Illustrated fig. 20.

SF 6 Several fragments of rim, body and base of beaker. Rim is slightly everted, body convex and base pushed in with a pontil mark. Decorated with two bands of horizontal plain trails in the centre of the vessel. Forest glass, green clear. No weathering.

Rim diameter 6 cm. Base diameter 4.8 cm. Illustrated fig. 20.

These three beakers are of a late sixteenth or possibly early seventeenth century date and due to their relative completeness were probably deposited whole into this pit.

They were of a less common form, not with a pedestal base but of a more simple pushed in variety and were almost certainly made in England (Charleston 1972: 146-148). They would appear to have been deposited at the same time and represent a small drinking group, possibly part of a larger clearance, with the other vessels found in the pit.

SF 7 1 large fragment of rim, neck, handle and shoulder of jug. Rim is everted with a pulled out pouring lip. Neck is narrow and tapers out to a convex shoulder. Handle is applied about 8 mm below the rim and has an applied triangular ring attached to it running around the neck of the vessel. Decorated with opaque white horizontal bands which are combed upwards and then marvered flat.

Soda glass, clear. Little weathering.

Rim diameter 2.8 cm. Illustrated fig. 20.

This large fragment of a jug is the only one found in a sixteenth or early seventeenth century context on this site. It is an unusual imported vessel, probably from Venice and dating to around 1600, although no direct parallel is known. This vessel's capacity was too small for it to have contained wine and may have been used for smaller quantities of liquids associated with the table. It is a quality piece and would have been considered of a higher status than an ordinary forest flask. The two other remaining vessels from this pit are both early case bottles.

SF 8 Several fragments of rim, neck, shoulder and base of hexagonal case bottle. Rim is slightly everted with a short neck, convex shoulder and the start of straight upright sides. The base is pushed in with the remains of a pontil mark. Not decorated.

Forest glass, green. Little weathering.

Rim diameter 2.4 cm. Base diameter 4.8 x 4.8 x 4.8 cm. Pontil diameter 1.2 cm. Illustrated fig. 20.

SF 9 Several fragments, complete profile, of large hexagonal case bottle. Rim is irregular and everted, neck tapers out to a rounded shoulder. The sides are straight and upright, with a thick pushed in base the a distinct pontil mark. Not decorated.

Forest glass, green. Some weathering.

Rim diameter 2.8 cm. Base diameter 8 x 8 x 8 cm. Pontil diameter 1.6 cm. Illustrated fig. 20.

These two case bottles are typical of the octagonal variety produced in the late sixteenth and early seventeenth century (Charleston 1984: 91-94). They were initially blown onto a hexagonal mould up to the level of the shoulder, then removed and the rim formed. An almost identical complete hexagonal bottle of this variety was found at the site of the Woodchester glass house (Ibid. 91 plate 18b), as well as at Denton (Hogan 1970: 25 fig. 2b). Like the beakers from this pit they are in such a complete state, that it suggests that they were deposited whilst whole or nearly so. They were most probably used to hold wine as they date to before the introduction of the wine bottle in the 1630s (Charleston 1984: 94-95). They could equally have held any liquid that could be stored and transported in such a vessel. It would seem that this less common octagonal variety did not last as long in its production and use in comparison to its square counterpart, they do not seem to occur in this form after the early years of the seventeenth century (Ibid.).

The four tenements which were excavated produced a total of nine vessels, all deposited just before or around 1600. Four forest glass beakers, a soda glass jug, a soda glass goblet and three case bottles were found. This represents quite a large group of drinking vessels, some of which were nearly whole, probably from a single property along this row. H.E. Salter in his detailed survey of Oxford, identifies these tenements. Numbers 32-34 Church Street were the property of Lincoln College and was occupied in 1547 by Joan Bonwell (Salter 1969: 72-73). The other excavated tenement, number 31, known as Whitehall, was owned by the Gunter family in the second half of the sixteenth century. It is unclear to which of these tenements these pits related to, but they were by their location, more likely to belong to the house

known as Whitehall. Unfortunately it is not possible to directly link these deposits with any single person.

b) 124 High Street

This area was excavated in 1961, although little report has been made of the excavations, save for a brief note. (Oxoniensia, 1961, p.338). When the site was uncovered a number of pits were discovered, of which the largest dated to the very early seventeenth century and it was within this pit that eleven vessels were found.

SF 1 4 fragments of body and 1 of rim of beaker. Rim is upright rim and body straight sided. Decorated with eight thin applied horizontal trails.
Forest glass, green. Some weathering.
Rim diameter 6.5 cm. Illustrated fig. 21.

SF 2 1 base of beaker. Base pushed in with a low kick and a thick applied flattened base ring. Not decorated. Forest glass, green.
Base diameter 5.5 cm. Not illustrated.

SF 3 1 fragment of rim of beaker. Rim upright with slightly tapering in sides. Decorated with very faint mould blown diamond pattern.
Forest glass, green clear. Quite weathered.
Rim diameter 7 cm. Illustrated fig. 21.

These three beakers are all of the common forest glass type and date from the very end of the sixteenth century. The beaker with the applied thin trails is a more unusual form and is similar to several forms found at Hutton (Charleston 1972: 150 fig. 67). These vessels were all probably used for beer and related directly to the other material found on the site, which is discussed at the end of the section. The site also produced the remains of five goblets.

SF 4 1 large fragment of stem of goblet. Stem is a separately made hollow inverted baluster which joins the top of a wide flaring base. Stem joined to bottom of the goblet bowl by a small solid rounded top knop and flattened annular knop. Base of bowl appears to be steep sided. Not decorated.
Soda glass, clear. No weathering.
Baluster diameter 2.9 cm. Illustrated fig. 21.

SF 5 2 large fragments, joining, of upper base, stem and lower bowl of goblet. Base is wide and flaring. Attached to a lion mask stem blown in a two piece mould. (see illustration). Stem joined to lower bowl by an annular solid knop. Bowl is convex and quite steep sided.
Soda glass, clear. Little weathering.
Stem diameter 3.3 cm. Illustrated fig. 21.

Figure 21 - High Street Glass.

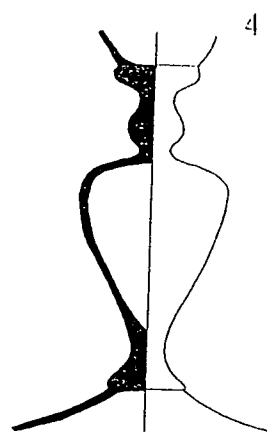
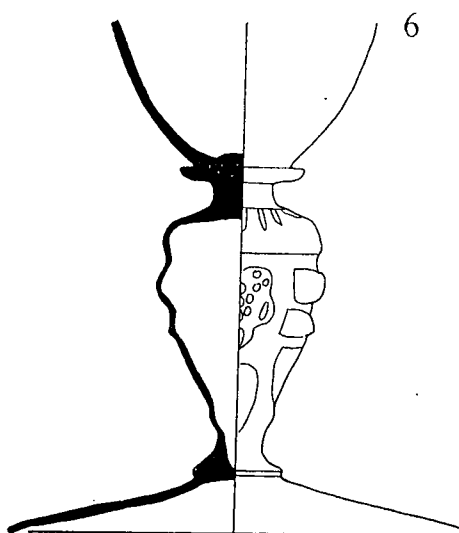
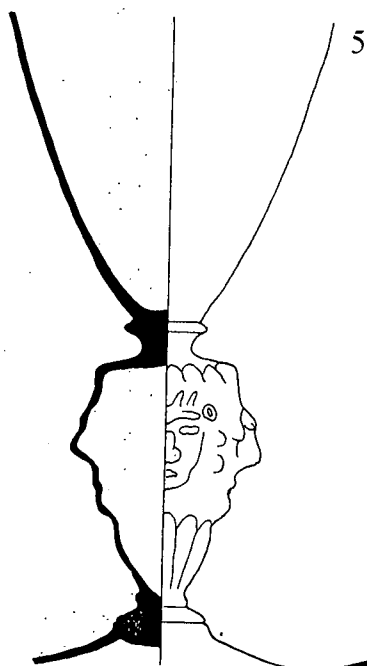
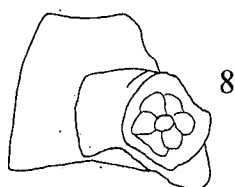
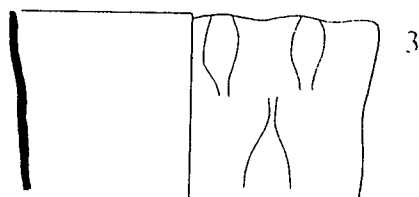
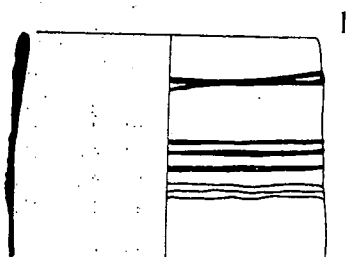

SF 6 1 large fragment of complete base, stem and lower bowl of goblet. Base is flaring and wide, attached to the stem as a separate item. Stem is blown into a two piece 'ladder' mould (see illustration) and attached to the bowl by a short extension and an upper solid annular knob. Bowl is convex and quite steep sided. Soda glass, clear. Little weathering.

Base diameter 8.5 cm. Stem diameter 3.2 cm. Illustrated fig. 21.

These three goblets are all made of soda glass. The first, SF 4, is a plain inverted baluster shape stem which first appears in the last quarter of the sixteenth century, although this one is of a better quality metal and probably dates from around 1600 (Charleston 1984: 68). The bowl and the base were of a similar form to the other two soda goblets. The lion mask stem goblet, SF 5, is typical of a form that occurs between 1550 and 1640 all over Europe (Thorpe 1961: 128). This form of stem in general is unusual in that it appears to have been made to the same form over this period by a number of glass houses. At the present time the only way to date these vessels is by the styles of the bowls, and the lower bowl of this vessel appears to date from the last quarter of the sixteenth century (Ibid.). The only other form of two piece mould blown stem is represented by SF 6, the 'ladder' stem. However this form varies in that it does not appear as early as the lion mask stem, the earliest positive date coming from the Winifred Geare glass made in 1590 by Verzelini (Thorpe 1961: plate 16a). These stems also appear to be exclusively produced in England, not appearing on any continental forms (op. cit. 128-129). It is most likely that all these goblets are of English manufacture and it is particularly interesting to see one of each type represented in this context. Two further fragments of goblets were found, but these are both of forest glass.

SF 7 2 fragments of rim of goblet. Rim is upright with straight vertical sides. Not decorated.

Forest glass, green. Some weathering.

Rim diameter 6 cm. Not illustrated.

SF 8 1 fragment of bowl of goblet or beaker. Curving convex side. Decorated with a single applied rosette prunt. Forest glass, green. Some weathering.

Illustrated fig. 21.

The first fragments of a goblet are of a form that has been found at the late sixteenth century production sites of Hutton and Rosedale (Charleston 1972: 148). This forest goblet survives as a form into the early seventeenth century and is found on a variety of sites, a later example coming from the glass hoard at Gracechurch Street, London

(Oswald 1949: 30 no. 2). Unfortunately without the stem or the base it is impossible to date this vessel accurately. The second fragment from a forest beaker is decorated with a rosette prunt and is probably the remains of a late sixteenth century plain beaker from the Low Countries (Henkes 1994: 152-153). Two further vessels were found in this pit, which are not drinking vessels.

SF 9 1 fragment of rim of urinal. Rim is horizontally everted with a slight upturn on the edge. Not decorated. Forest glass, green. Quite weathered.
Rim diameter 9 cm. Not illustrated.

SF 10 5 fragments, 3 joining, of shoulder of flask. Shoulder is convex. Decorated with mould blown wrythen decoration.
Forest glass, green. Some weathering.
Not illustrated.

These fragments from both a urinal and a flask are both common forest examples of these types. Most contexts with glass in them will contain fragments of either or both of these vessel types (Charleston 1972: 145). However when the entire group of glass is studied as a whole there does appear to be a very high proportion of beakers and goblets compared to other vessel types. Eight drinking vessels were deposited in this pit in one action, a large quantity for an ordinary domestic pit. This quantity of drinking vessels might be suggestive of a more communal property such as an inn.

Salter's survey of Oxford includes the High Street and this tenement (Salter 1960: 175). In 1457 the property is referred to as The Bear, whilst in the reign of Henry VIII it is mentioned as '*an inn called the Bear in the tenure of Henry Stanley*' (Salter 1960: 175). Salter also reveals that the tenant in 1606 was Richard Bryan, possibly the person responsible for the pit deposit of old, or unfashionable glass. This deposit and the documentary evidence both lead to the conclusion that this tenement was an inn. This would explain the large proportions of drinking vessels. It is interesting to note that both beer and wine vessels were used, indicating the preferences for both forms of drink in this establishment. All the beer beakers were of ordinary forest glass, with no soda examples, whilst both soda and forest goblets were being used. All the glass appears to be of English manufacture, perhaps indicating that imported vessels were not common in public areas of drinking in Oxford (Charleston

1972; Hurst-Vose 1994). Unfortunately other potential sites from inns do not have this additional documentary evidence to support them. However in this case a large group of drinking vessels can be demonstrated to be from such a site. What is interesting is that, although wine was clearly being served at this site, there is no evidence for the use of glass vessels to contain and serve it. Even though this deposit is too early for the first 'wine bottles' it might be expected to show evidence for the use of case bottles. As this is not the case wine must have been, by assumption, stored and contained within casks or other organic containers which do not survive archaeologically.

Both the groups from Church Street and the High Street contain a large proportion of drinking vessels. Church Street does have the remains of three case bottles of an early form and it is possible that these functioned in a very similar manner to the ordinary forest flask. However both sites seem to show, especially in the case of the High Street, a deliberate clearance of glass drinking wares in one action. This is an interesting activity which is discussed later in chapter eight. On both these sites soda and forest glass occur together and it is probable that they were used inter-changeably in a drinking or dining context. However in the case of the known inn on the High Street, from which the second group of glass comes, there appears to be some differentiation between metal types. All the goblets, with the one exception, occur in soda glass and all the beakers are of forest glass. This apparent assignation of glass metal to vessel form is fully discussed in chapter eight.

Chapter 5-Northampton

Northampton is a town with a long history of occupation, with prehistoric and Roman settlements existing in the immediate vicinity of the modern town. The present site was probably first occupied in the early medieval period, and by the tenth century there was a thriving Saxon ecclesiastical and administrative centre, with both a minster and a palace (Williams 1979: 4-5). By the twelfth century Northampton was a town undergoing large expansion and this is reflected by the building of one of the largest circuits of walls from any English town, although it is doubtful if this area was ever fully occupied. However this early expansion seems to have been ill founded and from the fourteenth century the town was in gradual decline, until the great fire of 1516 which reduced Northampton's status to little more than that of a small regional centre (op. cit. 6).

Since the 1970s, with the establishment of the Northampton Development Corporation, a number of systematic excavations have taken place mainly under the direction of John Williams. These excavations were typified by their quality of recording and by their prompt publication which makes both the artifactual material and the contextual information easily accessible. Northampton is an ideal settlement in which glass of the sixteenth century can be studied in the context of a small regional centre. Three major excavations undertaken since the 1970s have produced good groups of sixteenth century material, St. Peter's Street, Marefair and Mayerhold. These three excavations all lie within the area that Speed's map of Northampton in 1610 suggests was occupied, figure 23. The fourth site of Canons Ashby is also examined, as this site is not from the centre of Northampton and serves as a useful contrast.

a) St. Peter's Street

The excavation that has produced the most comprehensive evidence for medieval Northampton, as well as being well known for the famous Saxon mortar

Figure 22- Northampton Site Locations.

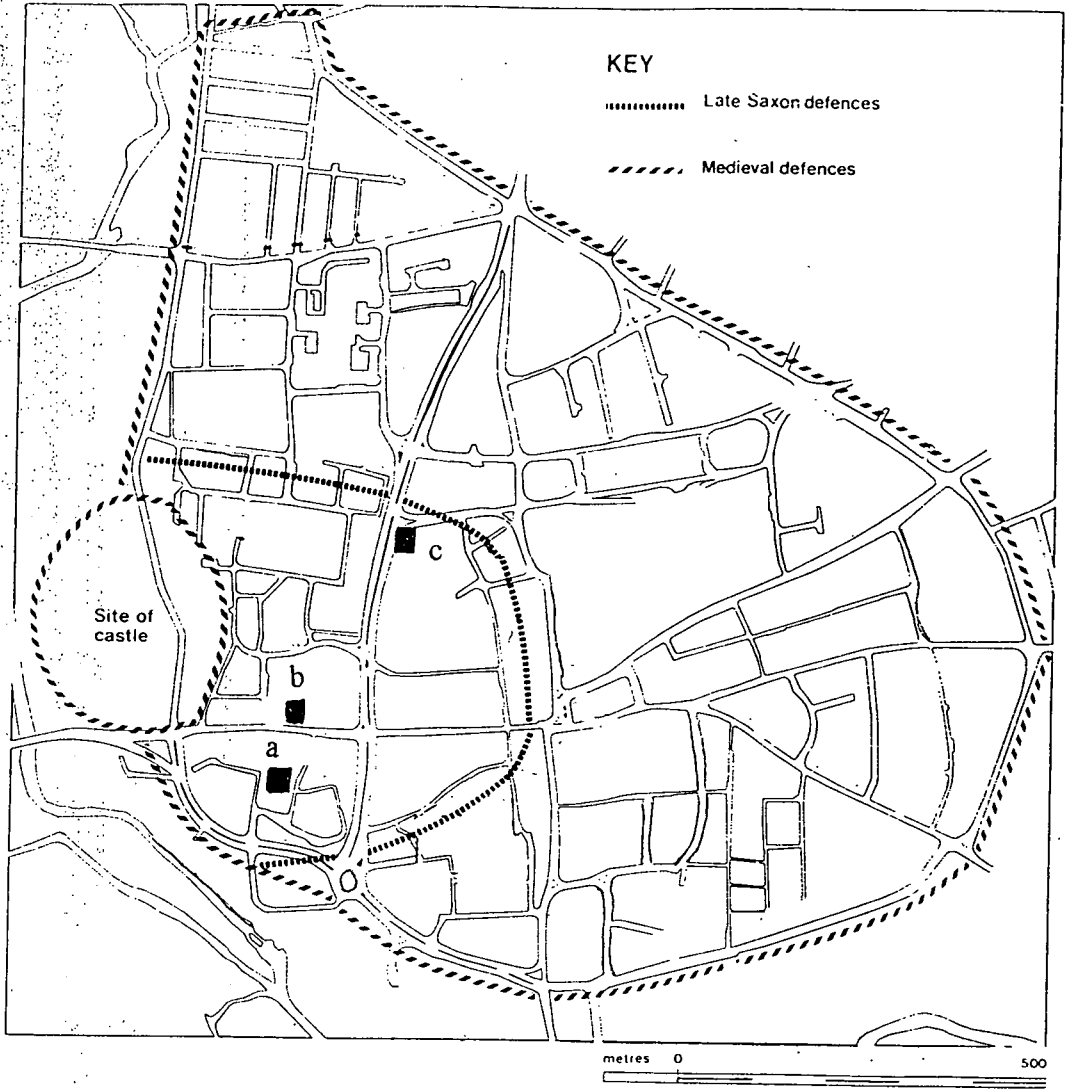

a: St. Peter's Street b: Marefair c: Mayorhold

Figure 23- Speed's Map of Northampton.

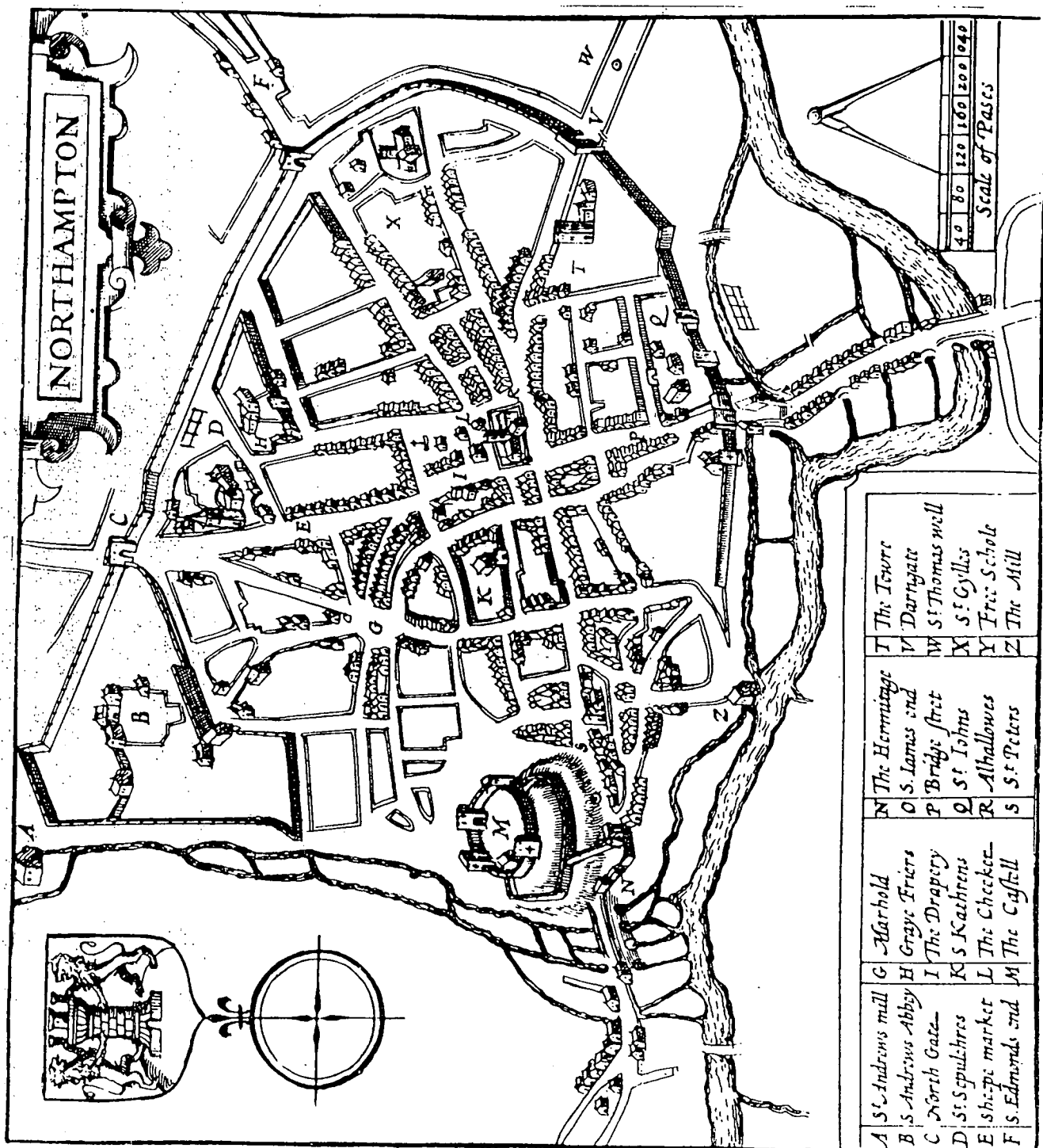

mixers, is that of St. Peter's Street. The site was dug for the Northampton Development Corporation by John Williams between June 1973 and June 1974 (Williams 1979). Two frontages on either side of the old medieval street were exposed as well as a limited transect across it (fig. 24). Unfortunately the majority of the post medieval layers were machined from the site before excavation and the last main phase of building exposed was built around the beginning of the fifteenth century. However there is evidence that occupation occurred into the seventeenth century on some parts of the site. Seven houses were discovered on the north side of the road and three to the south. The early fifteenth century houses on the north side were rectangular, between eight to twelve metres long and six metres deep. Those on the south side are more disturbed but were probably of similar proportions. The excavator believed that due to the nature of their deep stone foundations they were stone for at least one floor, possibly with an upper floor built in timber (op. cit. 145). The integration of industry, such as tanning in House 4 and drying ovens in House 10, led Williams to suggest that these dwellings, although not mercantile in nature, were probably of a middling artisan group (Ibid.).

In the late fifteenth century some minor modifications were made to the houses and a new building, house seven, was added to a similar plan. However the first quarter of the sixteenth century saw the evidence for the destruction of much of the street by fire and Williams suggests that the 'land presumably once more became derelict' (op. cit. 147). This may not have been completely the case as house ten continues to function as a tannery and there was probably other use and maintenance of the previous property boundaries, a possibility suggested by the material culture. Whether this is the case is uncertain as modern development and the machining of the site removed evidence for this period. There were certainly deliberate pit depositions of groups of artifacts in the sixteenth and early seventeenth centuries.

Of the glass vessels that can be positively identified from the whole site, with the exception of two beakers SF 2088 and SF 1937c, all are forest glass and almost certainly made in England. They are of forms commonly found in sixteenth century

Figure 24- St. Peter's Street Plan.

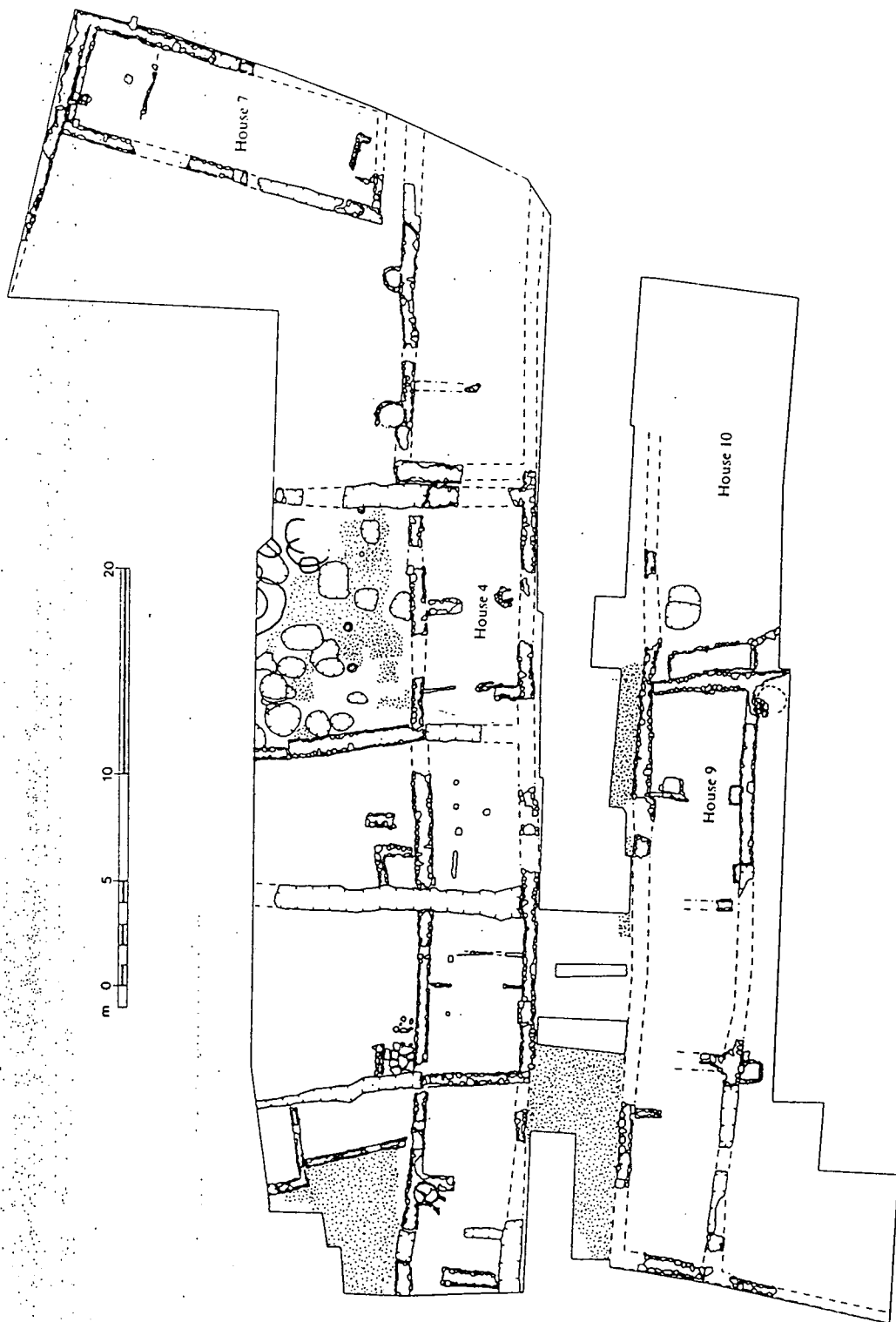

contexts or on identified production sites, such as the glass houses at Hutton and Rosedale (Charleston 1972: 146). A total of thirty two different vessels were recovered from St. Peter's Street and these vessels came out of the contexts of only four of the ten excavated houses. The majority of the glass dealt with here is from the last quarter of the sixteenth or the very early seventeenth century. It is important to stress that with all the house sites, except House 10, the glass is not directly contemporary with the excavated fifteenth century structures. It is usually present in features cut into these excavated buildings, thus creating an indirect link. However the presence of this material could be explained by its deposition soon after the disuse of the structures, as some form of clearance. It is more likely that later buildings machined off the site or not recovered by excavation, produced this material. As House 10 continued to respect the earlier land plots, it is likely the same was the case for the others, so it is still valuable to study the glass in the context of these building plots (Williams 1979: 98-103).

House 4

House 4, along with House 3, was the first house along the north side of the road to be consolidated in stone at some point in the late thirteenth century. Later development saw little change to its plan, with only some minor alterations occurring to its plan until its apparent destruction and abandonment in the early sixteenth century (op. cit. 46). Only one fragment of unstratified glass was found in this house plot.

SF 3127 1 complete base of bottle. Base is pushed in with low irregular kick and faint pontil mark. Decorated with faint mould blown wrythen.
Forest glass, green. Heavy weathering.
Base diameter 7.5 cm. Not illustrated.

This type of small bottle is common form in the second half of the sixteenth century and was probably used to hold limited amounts of liquids or medicines (Charleston 1972: 145). This find was probably part of the residual make up of the site.

House 7

House 7 was the last of the properties on St. Peter's Street to be consolidated in stone, sometime around the end of the fifteenth century, figure 25. It was a slightly larger building, being sixteen by six metres. It was probably abandoned in the first quarter of the sixteenth century (Williams 1979: 67). Only two fragments came from contexts associated with actual building features, this context being sealed beneath iron and limestone paving, layer 31, at the south end of the building.

CONTEXT B1329

SF 3356a 1 large fragment of base of beaker. Base is a pushed in pedestal with folded over base ring. Not decorated. Forest glass, green. Medium weathering.
Base diameter 10.5 cm. Illustrated fig. 25.

SF 3356b 1 small fragment of base of beaker. Base is a pushed in pedestal with folded over base ring. Not decorated. Forest glass, green. Quite heavily weathered.
Base diameter 9.5 cm. Not illustrated.

These two fragments represent a limited deposition during the life span of the building and are both fragments of the beaker type common in the second half of the sixteenth century and in the first quarter of the seventeenth (Charleston 1984: 87-89). They are clearly later than the building, but are in a sealed pit context dug into it, suggesting that to some extent there was a continuation or re-use of the building. The other context from which the majority of the glass comes from in this building is a pit, C63, cut into the north wall of the building, presumably after its abandonment. Only a portion of this pit could be excavated but it produced several glass vessels and other associated material.

PIT C63

SF 965 1 complete base and lower body of beaker. Base is a pushed in pedestal, with medium kick, pontil mark and folded base ring. Lower body tapers with a convex profile. Decorated with mould blown overlapping ovals or 'fish scale' decoration.
Forest glass, green. Some weathering.
Base diameter 6.5 cm, Surviving height 6.8 cm. Illustrated fig. 25.

SF 3298 3 fragments of rim and body of beaker. Rim slightly turned in, body convex and tapering. Decorated with mould blown vertical fluting on body (with slight upper twist) starting 0.75 cm below the rim. Forest glass, green. Light weathering.
Rim diameter 5.5 cm. Not illustrated.

Figure 25- House 7 Plan and Glass.

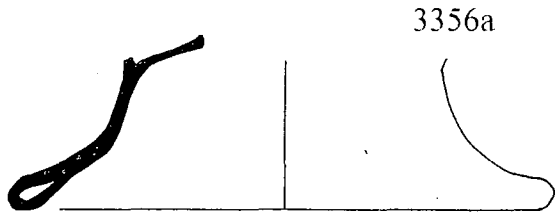
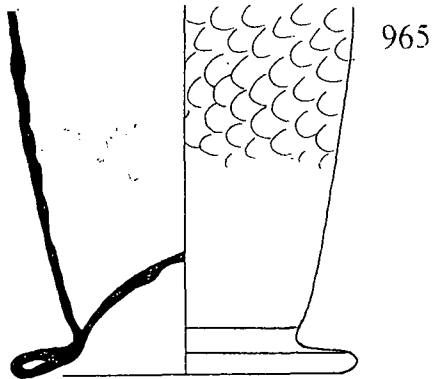
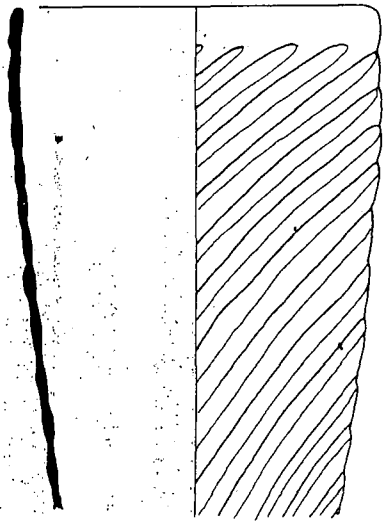
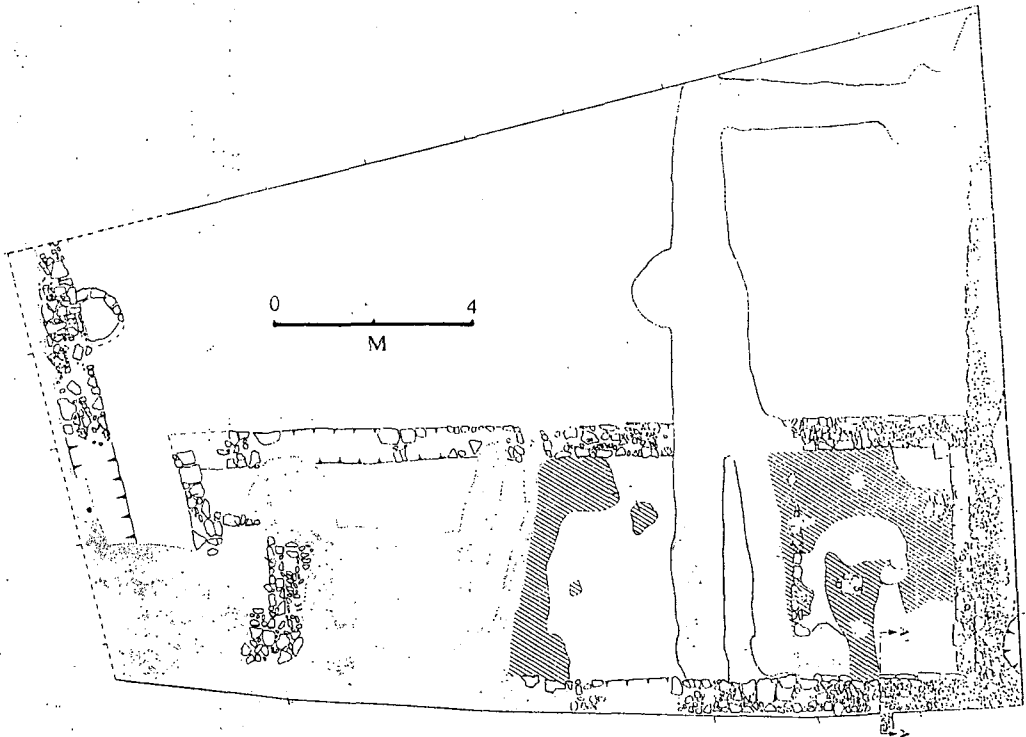

SF 3299 1 large fragment of rim and upper body of beaker. Rim slightly inturned. Body is convex and tapering. Decorated with mould blown wrythen decoration running from top right to bottom left. Decoration starts 1 cm below the rim.

Forest glass, green clear. Little weathering.

Rim diameter 6.8 cm. Illustrated fig. 25.

These three beakers are again typical English products from around 1550 to 1640 and are in a generally more complete state than usual, suggesting they might have been deposited whole or nearly so (Charleston 1984: 87-89). This pit also produced associated pottery wares, one Midland yellow tankard, five black iron glazed tankards and one type four Belarmine jug, dating from the very early seventeenth century, which were all complete or nearly whole (Williams 1979: 197). This partially excavated pit would seem to represent the deliberate deposit of at least nine (three glass and six pottery) drinking vessels in one action. There was no other pottery or glass from this context, and the filling of the pit suggests that this was the result of the clearance of an individual table set from a property, in the very early seventeenth century. This material must have come from a property very near by, if not on the site, and it is interesting that, from the house as a whole, the five glass vessels recovered were all drinking beakers.

House 9

Some time between 1410 and 1420 the stone building house nine was constructed, again being of rectangular dimensions, twelve metres by five, figure 26. There is consistent evidence that this building was destroyed by fire, around the beginning of the sixteenth century and the building from this phase is quite disturbed archaeologically (op. cit. 88). Consequently only one fragment of glass came from a stratified context, the fill of a robber trench of the south wall.

CONTEXT G12

SF 2063 1 fragment of body of beaker. Body is slightly convex. Decorated with mould blown lozenge decoration. Fragment from near the top of the vessel.

Forest glass, green. Medium weathering.

Body diameter 6 - 6.5 cm. Illustrated fig. 26.

Figure 26- House 9 Plan and Glass.

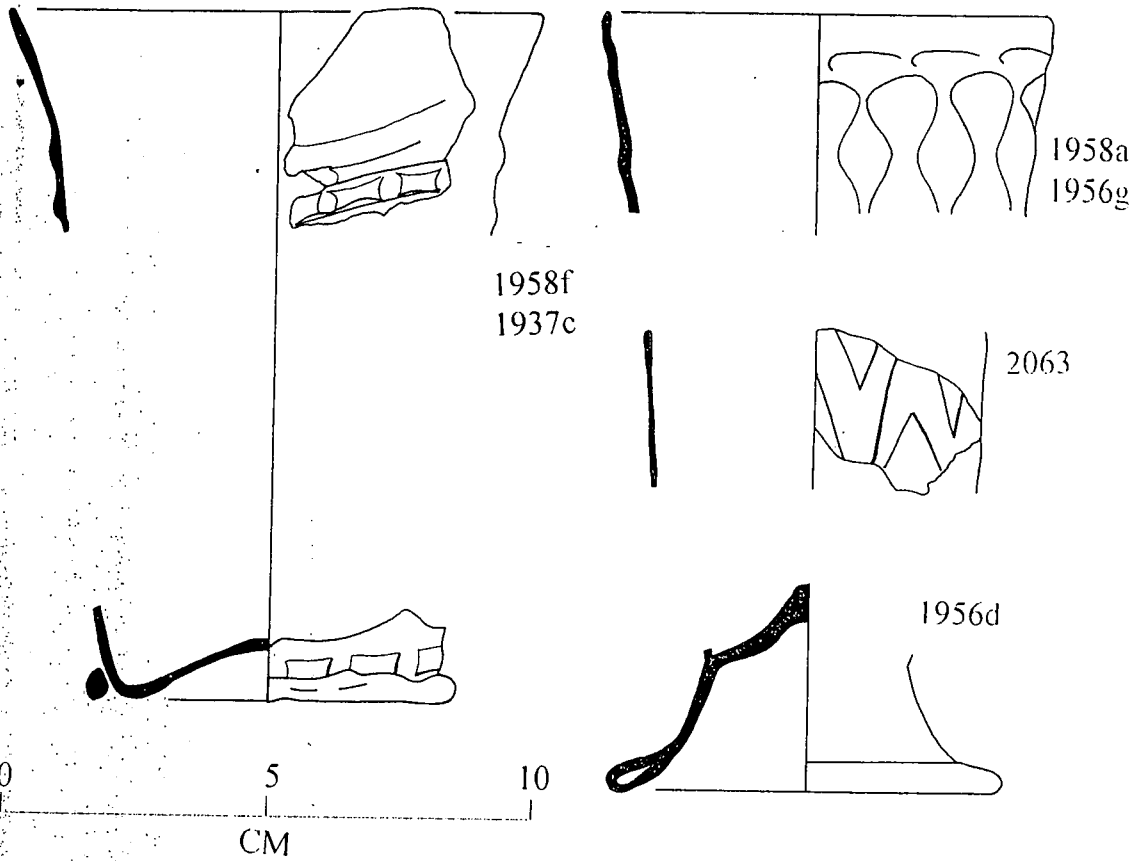
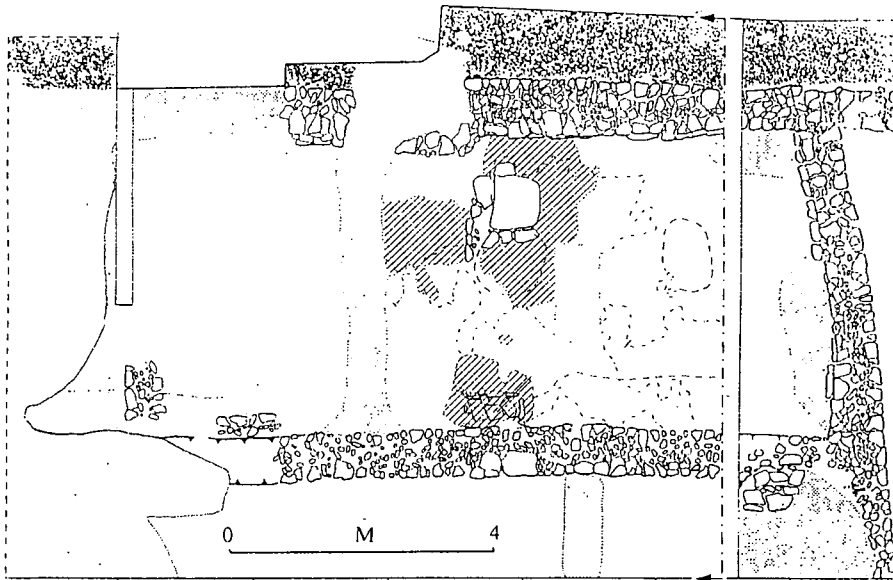

This small fragment from a typical mould blown late sixteenth century beaker lies in the robber trench of the wall could have been deposited any time during the sixteenth century. However there are a larger quantity of vessels, eleven in all, that also came from this area, but due to the disturbed nature of the site, are unstratified. Even without a context they still remain important.

UNSTRATIFIED

SF 1956a & 1937 2 small fragments of rim of beaker. Rim is slightly inturned. Decorated with remains of mould blown vertical fluting starting 0.5 cm below the rim.

Forest glass, green. Medium weathering.

Rim diameter uncertain. Not illustrated.

SF 1956b 1 fragment of rim of beaker. Rim slightly inturned in. Decorated with remains of mould blown wrythen decoration, running from top right to bottom left, just below rim.

Forest glass, green. Some weathering.

Rim diameter 7 cm. Not illustrated.

SF 1956c 1 fragment of body of beaker. Body is slightly convex. Decorated with mould blown wrythen decoration running from top left to bottom right.

Forest glass, green. Medium weathering.

Central diameter uncertain. Not illustrated.

SF 1956d 1 fragment of base of beaker. Base is a pushed in pedestal, with high kick and folded base ring. No decoration. Forest glass, green. Quite heavy weathering.

Base diameter 7.5 cm. Illustrated fig. 26.

SF 1958a & 1956g 2 fragments of a rim of beaker or goblet. Rim is slightly everted. Decorated mould blown rounded diamond pattern starting 0.5 cm below rim.

Forest glass, green. Quite heavy weathering.

Rim diameter 9 cm. Illustrated fig. 26.

SF 1958b 1 fragment of base of beaker. Base is a pushed in pedestal with folded base ring. No decoration. Forest glass, green. Some weathering.

Rim diameter 9 cm. Not illustrated

SF 1958c 1 large fragment of base of beaker. Base is a pushed in pedestal with folded base ring. No decoration. Forest glass, green. Some weathering.

Rim diameter 7.7 cm. Not illustrated.

SF 1958e 1 fragment of base of beaker. Base is pushed in pedestal with folded base ring. No decoration. Forest glass, green. Some weathering.

Rim diameter 8 cm. Not illustrated.

SF 2064 1 small fragment of base of beaker. Base is pushed in pedestal with a folded base ring. No decoration. Forest glass, green. Medium weathering.

Rim diameter 9 cm. Not illustrated.

SF 1958d 1 small fragment of base ring of flask. Base ring is folded over and from a pedestal base. No decoration. Forest glass, green. Medium weathering.

Rim diameter approximately 10 cm. Not illustrated.

These ten vessels, nine beakers and a flask, are all standard products of the end of the sixteenth century in England (Charleston 1972: 33, 87-89). It is unfortunate that they are unstratified as the proportion here of beakers is unusually high and suggests that these ten vessels do not represent a general distribution of artifact types. It is more probable that these vessels have come from one or more specific pit contexts which only contained drinking vessels, including pottery, such as the pit group from house seven. The small finds numbers allotted to these vessels during the excavation suggests that they were found together, although it is not possible to tell if other pottery vessels were present in the same context. It is quite possible to view, with a little caution, this group of almost exclusively beakers, as the result of one or more deposits which came from a building close by. Again, as with House 7, this could be interpreted as a clearing out of old vessels to allow for a new drinking set. Indeed it might be a single household or building that is responsible for these two depositions, and judging from the quantities of vessels this might have been a drinking establishment such as an inn. There were two fragments from a single vessel that were recovered from house nine as unstratified, which differ from the rest of the glass from this area. These are of soda glass and an import.

SF 1958F & 1937C 1 fragment of rim and 1 of base of a beaker. Rim is plain and widely everted. Body is straight and slightly tapering. decorated with two cut spiral trails. Base slightly pushed in and decorated with two rows of cut spiral trails underneath and one just above on the out side. Thick unevenly applied solid base ring.

Soda glass, clear. Little weathering.

Rim diameter 10 cm. Base 7 cm. Illustrated fig. 26.

This vessel is an imported *Wafelbeker*. These were quite a common vessel in use in the Netherlands and North Germany in the first quarter of the sixteenth century and the first quarter of the seventeenth. They take a very standardised form, with generally uniform rim diameters and were often decorated with rosette prunts, sometimes with an inserted blue bead (Henkes 1994: 129-132). The presence of a vessel such as this at Northampton suggests that the people living in the area of St. Peter's Street not only had access to English forest glass, but also higher quality imported material. Like the more ordinary forest beakers these vessels were popular for the consumption of beer

(van Dongen 1994: 14-15). In a context such as this, this vessel even though quite common in northern parts of the continent would have been a higher status object.

House 10

House 10 is the only structure where features that post date the first quarter of the sixteenth century were found. It occupies a twenty metre long area divided into two sections. The western portion consists of an open yard with eight to nine tanning pits and the eastern half appears to have been roofed and contained two troughs and a stone lined pit, figure 27. This last stage of the building seems to have been in use between 1575 and 1650, although the exact dating is uncertain (Williams 1979: 98-103). Most of the glass from this site was found in the tannery pits in the open yard, but two vessels were also found inside the structure.

GLASS FROM THE TANNING PITS

G87-Surface into which the pits are cut.

SF 3156 1 large fragment of base of flask. Base is pushed in with a high kick. No decoration.

Forest glass, green. Quite weathered

Diameter 10.5 cm. Not illustrated.

G71-Rectangular clay lined pit.

SF 2157 Numerous fragments of urinal. Body is of ovoid form, tapering to neck and base and blown very thin. Forest glass, clear green. Little weathering.

Greatest diameter 9 cm. Illustrated fig. 27.

G68-Rectangular clay lined pit.

SF 2243 1 fragment of a rim of beaker. Rim is slightly inturned. Decorated with traces of composite mould blown decoration. First twisted into a wrythen style, with ribs running from top left to bottom right, then blown into a broad spaced fluted optic mould.

Forest glass, deep green clear. Little weathering.

Rim diameter 7 cm. Illustrated fig. 27.

SF 2240 1 fragment of rim of beaker. Rim is slightly inturned. Decorated with mould blown wrythen decoration from top left to bottom right, about 0.75 cm below rim.

Forest glass, green. Some weathering.

Rim diameter 6.2 cm. Illustrated fig. 27.

SF 2093a 1 fragment of body of beaker. Body is convex. Decorated with heavy mould blown diamond decoration. Forest glass, green. Medium weathering.

Diameter uncertain. Not illustrated.

Figure 27- House 10 Plan and Glass.

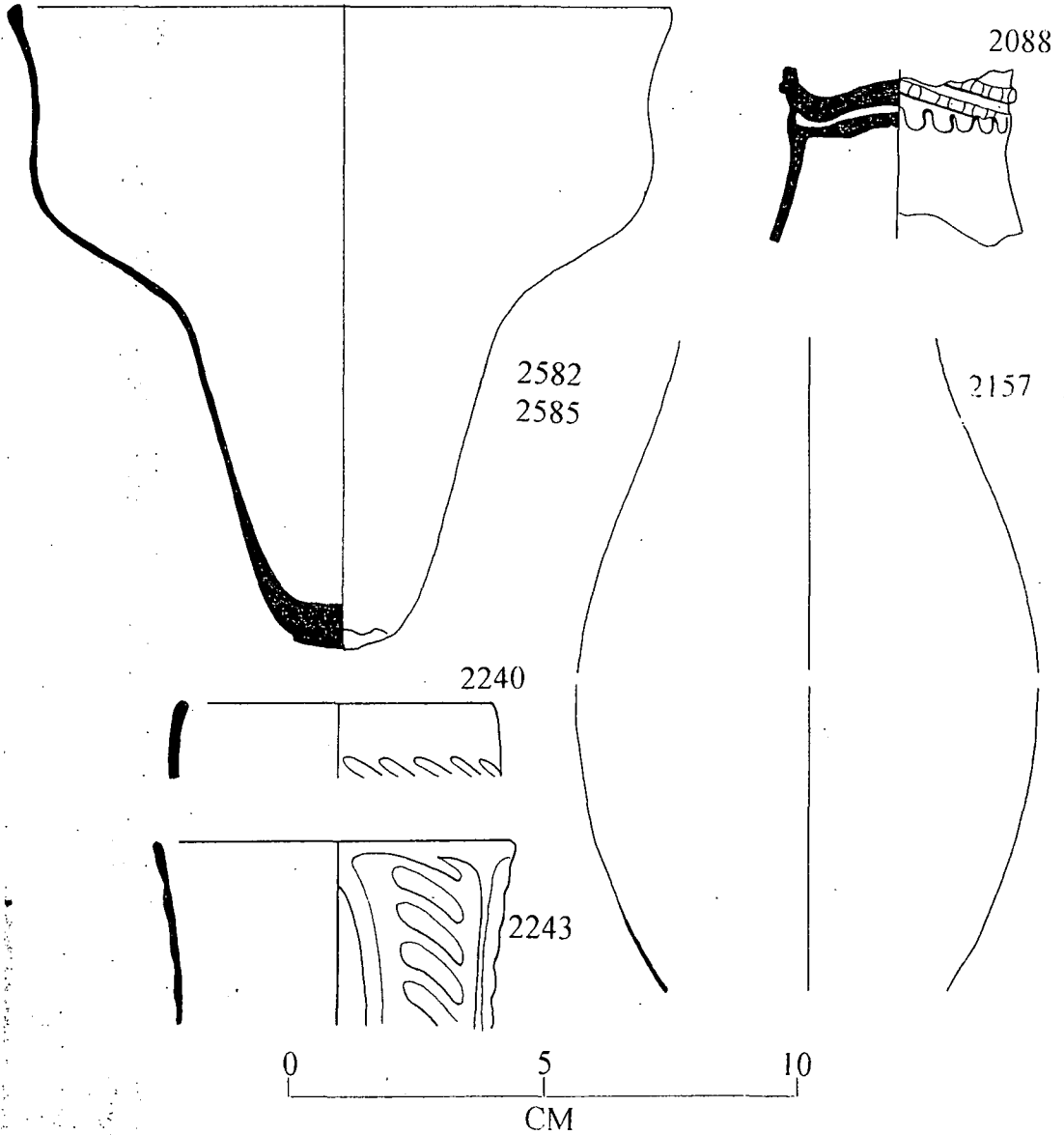
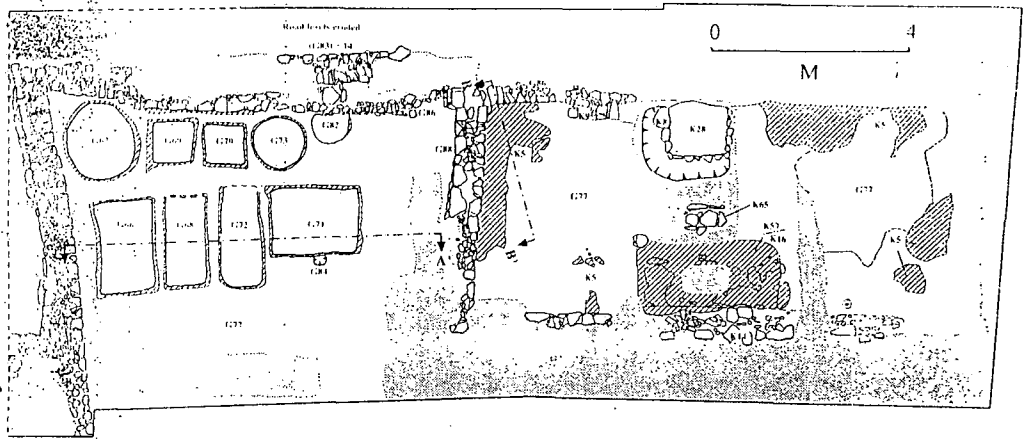

SF 2088 1 large fragment of body of beaker. Body made from two separate joined 'U' shaped pieces of glass, one forming the lower bowl and the other upper part of foot. Upper portion decorated with lowest two bands of a cut spiral trail and then the lower portion combed upwards to join it to the bowl.

Soda glass, clear. Little weathering.

Central diameter 4.5 cm. Illustrated fig. 27.

G69-Rectangular clay lined pit.

SF 2195 1 large fragment of base of oval bottle. Base is pushed in with a high kick. Decorated with the start of mould blown wrythen pattern on lower body.

Forest glass, pale green. Quite weathered.

Base diameter 5.5 x 6 cm. Not illustrated.

G73-Circular clay lined pit.

SF 2127 1 fragment of body of beaker. Body is convex. Decorated with mould blown heavy diamond pattern. Forest glass, green. Some weathering.

Diameter uncertain. Not illustrated.

GLASS FROM INSIDE THE STRUCTURE

K28-Stone lined pit

SF 2584 Neck, body and base fragments of small bottle/flask. Neck is plain, thick, and vertical. Body is convex body (blown very thin). Base is pushed in with medium kick. Not decorated.

Forest glass, blue/green clear. Little weathering.

Base diameter 7.5 cm. Not illustrated.

SF 2582 & 2585 Complete profile of a hanging lamp. Rim is slightly everted, shoulder is convex with a sharp turn leading to a tapering base. Thick at bottom with an external pontil mark. Almost all of the vessel present and restored.

Forest glass, dark green, medium weathering.

Rim diameter 13 cm. Height 12 cm. Illustrated fig. 27.

House 10 shows two contrasting types of deposit, the glass from the yard and that from the structure. Externally the glass is all of a very fragmentary nature, with these fragments being deposited in the tanning pits, probably more by accident than design. This is most likely to be the result of a general cleaning out of the structure into the yard of any debris. This idea is confirmed by the lack of glass, and indeed much material, from the structure, which seems to have been kept clean of debris. The only glass found inside were the bottle and the lamp which were probably deposited in the stone lined pit whilst intact, possibly for safe keeping. All the glass is consistent with a mid to late sixteenth century date, although this is confused slightly by associated material from the tanning pits. Tanning pit G71, in particular, contains a Charles I coin (1625-49) and a Nuremberg jetton (circa 1620), which initially might suggest a date for the glass in the first quarter of the seventeenth century (Williams 1979: 102). However if the tannery was in operation from around 1575 to 1650, then presumably these pits, if continuously used, could contain material from this whole period in a single context.

House 10 displays the characteristic glass material resulting from the general use and occupation of a site in the period 1575-1625. Like Houses 7 and 9 there appears to have been deliberate deposition of intact vessels, with the lamp and the bottle in the stone lined pit in the structure, which were probably only put there for temporary storage.

Trench 'E'

Trench 'E' was opened at the same time as the main excavations at St. Peter's Street, but further to the south running parallel to Free School Street, figure 28. It acted as a limited study of the building frontages along this street, but was unable to define the relationship between the building sequences it uncovered and the artifactual material. Four fragmentary glass vessels were found, all in the context that the excavator interpreted as the brown soil onto which the stone building was constructed (Williams 1979: 108).

Context E11

SF 1919a 1 fragment of rim of beaker. Rim is slightly inward turning rim from a beaker. No decoration. Forest glass, green clear, lots of bubbles. Some weathering.
Rim diameter 6 cm. Illustrated fig. 28.

SF 1919c 1 fragment of base, 2 of body of beaker. Base is pushed in pedestal with low kick and folded base ring. Body fragments convex and decorated with mould blown irregular lozenge pattern. Majority of vessel profile represented.
Forest glass, green clear. Little weathering.
Rim diameter 6.5 cm. Illustrated fig. 28.

SF 1919d 1 fragment of rim and neck and 1 of base of urinal. Rim horizontally everted with slight vertical upturn on edge. Neck is vertical and narrow. Base is thick and convex with external pontil mark.
Forest glass, green. Very heavy weathering.
Rim diameter 9 cm. Illustrated fig. 28.

SF 1919b 1 fragments of shoulder and of 1 body of jar. Shoulder is sharp and convex, leads to curved everted rim (now missing). Body vertical. Decorated on both shoulder and with heavy mould blown wrythen running from top left to bottom right.
Forest glass, green clear. Some weathering.
Shoulder diameter 5.5 cm. Illustrated fig. 28.

Trench 'E' produced the same forms of English made wares as the main excavation at St. Peter's Street, with the exception of the more unusual jar fragments. Like the main

Figure 28- Trench 'E' Plan and Glass.

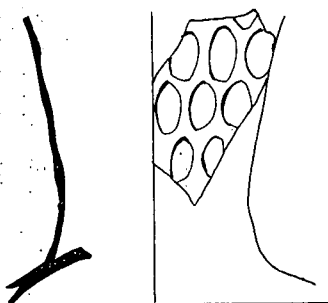
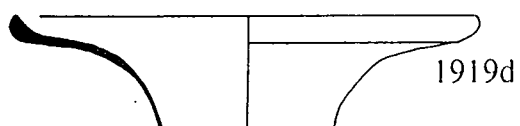
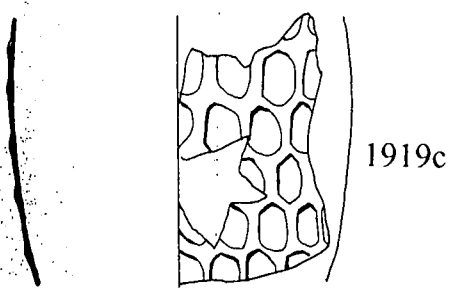

1919a

1919b

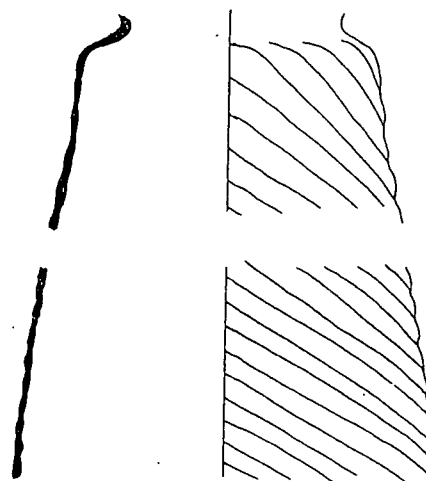

excavations this material is late sixteenth century or very early seventeenth and was deposited during the building's life span. However it is not clear whether it was all deposited at once. This is entirely possible given the small size of the context, although it might have been a gradual accumulation of material.

b) Marefair

The Marefair excavations took place between 1976 and 1977 on a corner plot between Marefair and Quart Pot Lane, figure 29. The excavations revealed a thirteenth to fourteenth century stone built house and yard and demonstrated its subsequent robbing and development. Unfortunately the nature of the site is such that it is impossible to directly associate the excavated glass with specific features of the later building. It does however relate, in some contexts, to the site after the life of the excavated stone building. The nature of the contexts is such that they are so disturbed that sixteenth century glass occurs in phases as diverse as the fifteenth century to the eighteenth century. However if the glass is examined in its relative position in the town as a whole, it is a valuable indicator of what was occurring on the Marefair site in general.

GL 1 5 fragments, joining, of body of beaker. Body is straight sided. Decorated with four applied horizontal pinched trails.
Forest glass, green. Quite heavily weathered.
Body diameter 7 cm. Illustrated fig. 30.

GL 13 8 fragments, 5 join, of base of flask. Base is pushed in pedestal with very shallow kick and folded base ring. Not decorated.
Forest glass, green. Very heavily weathered.
Base diameter 7.5 cm. Illustrated fig. 30.

GL 28 1 fragment of small handle of small jug. Handle is small and curving. Decorated with applied thin trail on outer face.
Forest glass, green. Medium weathering
Thickness 1.75 cm. Not illustrated.

GL 66b & 69 3 fragments (joining), 2 of rim, 1 of neck of urinal. Rim horizontally everted with slight vertical up turn on edge. Neck narrow and straight. Not decorated.
Forest glass, green clear. Some weathering.
Rim diameter 9 cm. Not illustrated.

Figure 29- Marefair Plan

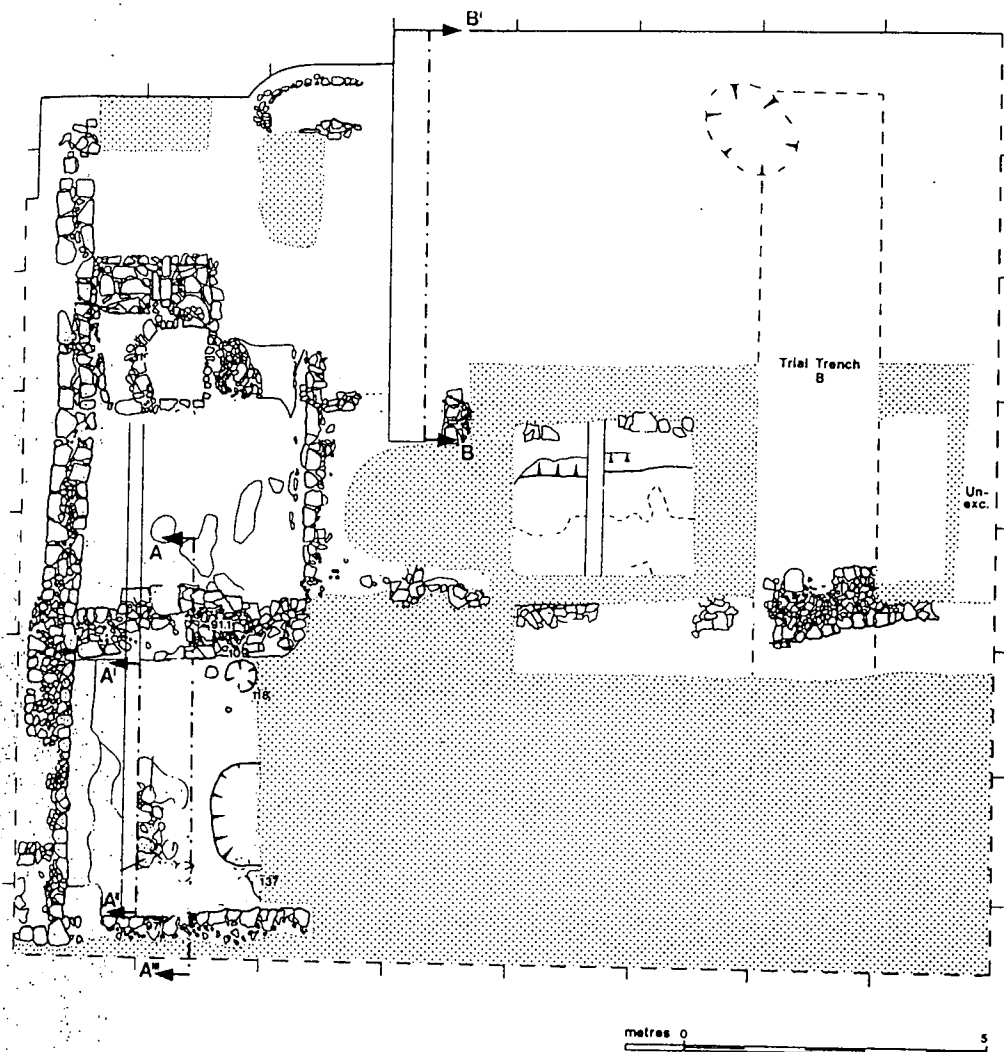

GL 66a 4 fragments of rim (joining) of beaker. Rim is slightly inverted. Decorated with mould blown vertical fluted decoration.

Forest glass, green clear. Some weathering.

Body diameter 5 cm. Illustrated fig. 30.

GL 77 1 fragment of body of flask?. Body is convex. Decorated by partial grinding of ovoid shape on part of surface.

Soda glass, clear. Little weathering.

Body diameter uncertain. Not illustrated.

GL 134 (Trench D) 1 very large fragment of rim, neck, shoulder and start of side of a case bottle. Rim very thick, initially everted but turns in at top. Thick neck tapering outwards with raised 'string course'. Shoulder convex and leading to thinning vertical straight side. Not decorated.

Forest glass, deep green, little weathering.

Internal rim diameter 4 cm. Body diameter 14.5 x 14.5 cm. Illustrated fig. 30.

The excavation at Marefair produced a total of eight vessels, seven of which were of English forest glass. The earliest fragment is probably that of the cut trailed beaker, GL 1. This type is similar to the wares being produced in the Wealden glass houses at the beginning of the sixteenth century and is the most weathered glass (Kenyon 1967: plate 19 vessel a). Small jugs with handles were also produced in this period and GL 28 is most probably contemporary to this. The flask GL 13 and the beakers GL 66a, GL 120 and GL 122 are later English products dating to the second half of the sixteenth century and are typical of the products from the later glass houses such as Hutton and Rosedale (Charleston 1972; Thorpe 1961: plate 16). Only one fragment of soda glass was recovered from the site, GL 77, and this small fragment appears to be from the body of a convex flask. The abrasion might be decoration, but it does not appear to resemble the diamond point engraved vessels of the latter half of the sixteenth century (op. cit. plate 16). Whether this vessel is indeed from the sixteenth century and its area of origin is uncertain from a fragment of this size. The final vessel is the large portion of a case bottle, GL 134, which did not come from the main excavation, but from a small trial trench to the west, figure 29. This vessel, although probably not from the sixteenth century but the seventeenth, is worthy of note as it is an early example of this form. The rim has not yet fully developed into the final form of the case bottle (Charleston 1984: 91-92). This is likely to date from the first quarter of the seventeenth century, but might be earlier, although without further contextual dating this is hard to ascertain.

Figure 30- Marefair and Mayorhold Glass.

Marefair

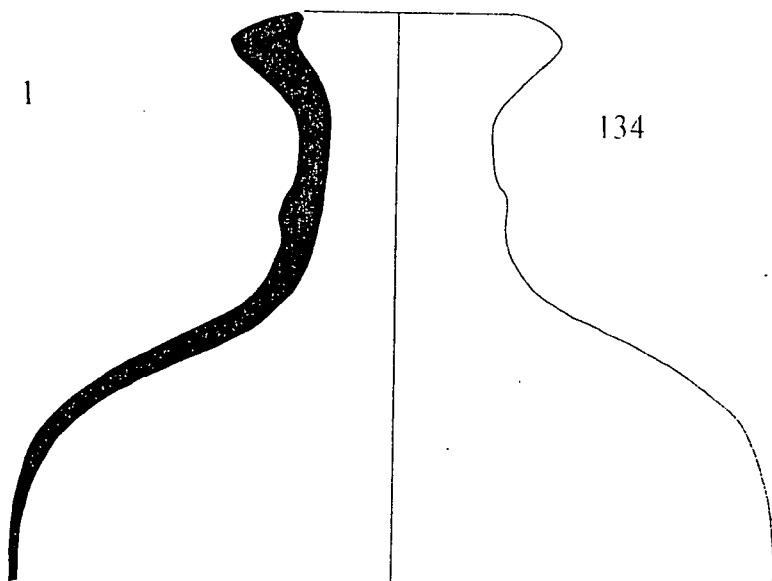
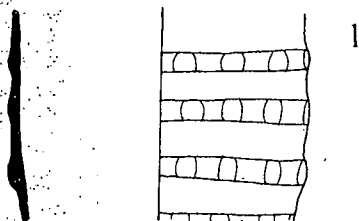
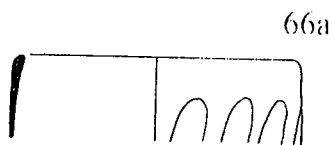
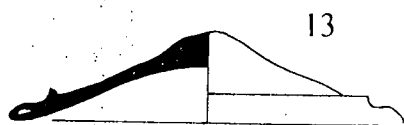

Mayorhold

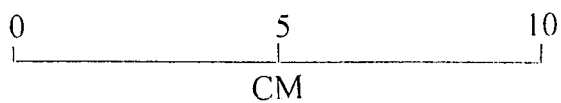
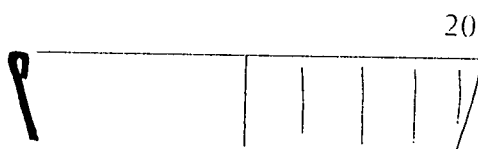
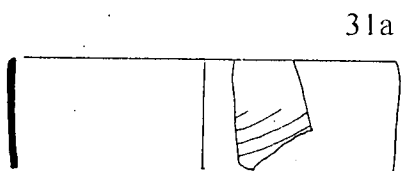

Therefore the Marefair group of glass, although small and without contextual information is still an informative collection of sixteenth century material. Vessels of all periods in the sixteenth century occur here and it resembles the St. Peter's Street material, mainly being of ordinary forest glass.

c) Mayorhold

The excavations at Mayorhold produced domestic occupation evidence for periods from the twelfth century to the sixteenth. In the latest phases a few walls and a hearth associated with a sixteenth century building were found, although its full plan cannot be determined (figure 31). Later unrecorded post medieval disturbance obliterates much of the structural and contextual evidence in this limited excavation plan. Therefore the recovered glass is restricted in its application. However the general distribution within the context of the town of Northampton as a whole is useful and it additionally indicates which glass products were being used in the sixteenth century. Five identifiable vessels were excavated.

GL 11.1 fragment of base of urinal. Base is thick and convex with external pontil mark. Not decorated. Forest glass, green. Heavy weathering. Not illustrated.

GL 15.1 fragment of base of urinal. Base is thick and convex with external pontil mark. Not decorated. Forest glass, green clear. Some weathering. Not illustrated.

GL 20 1 fragment of rim of goblet? Rim is slightly everted with the top edge folded inwards. Decorated with feint mould blown vertical fluting. Soda glass, clear. Little weathering. Rim diameter 9 cm. Illustrated fig. 30.

GL 31a 2 fragments (joining) of rim of beaker. Rim is vertical. Decorated with mould blown wrythen decoration running from top right to bottom left. Wrythen starts 1 cm below rim. Forest glass, green. Quite weathered. Rim diameter 7 cm. Illustrated fig. 30.

GL 31b 1 fragment of neck of flask. Neck is vertical. No decoration. Forest glass, green. Heavy weathering. Neck diameter uncertain. Not illustrated.

The glass from Mayorhold is therefore very similar in nature to both St. Peter's Street and Marefair. There is only one piece of unusual optic blown soda glass SF 20, and

Figure 31- Mayorhold Plan.

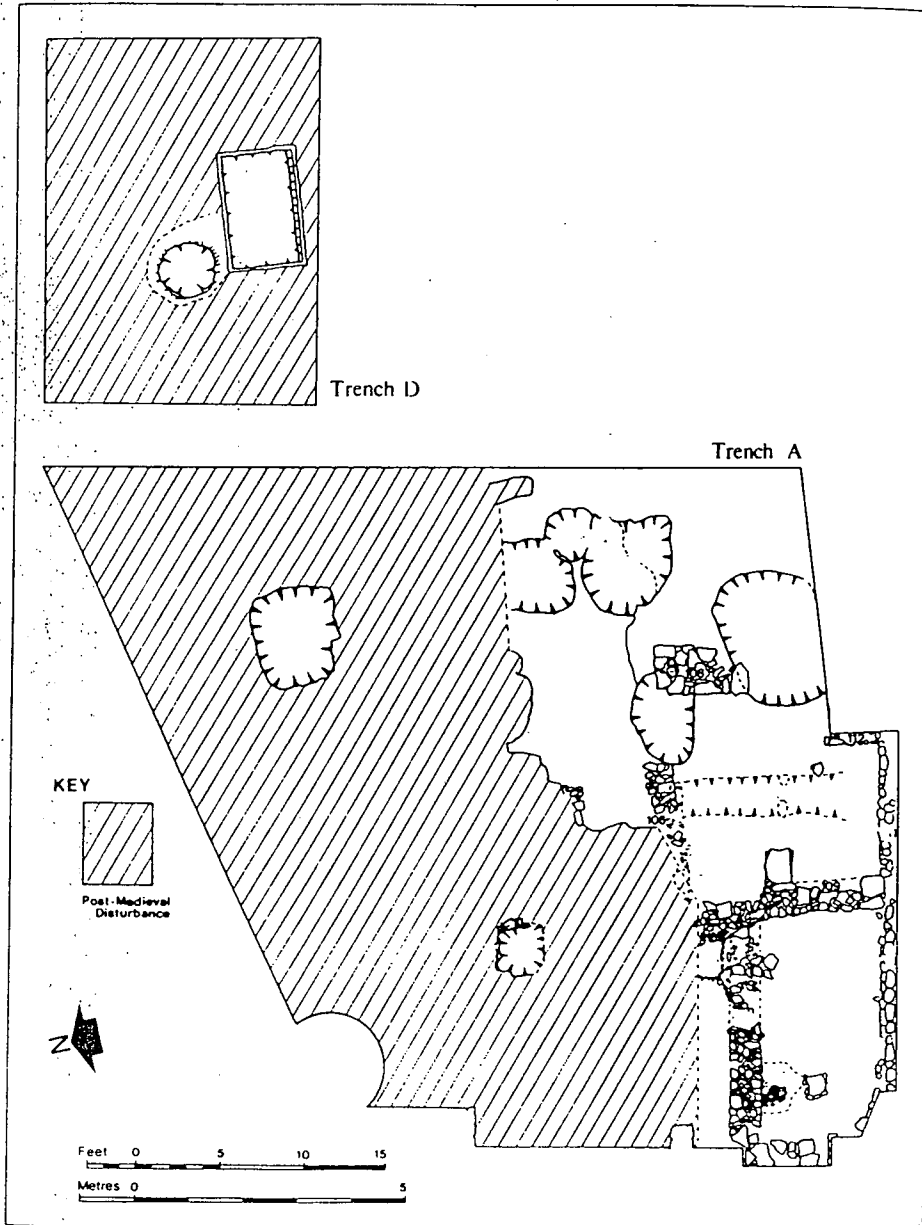

this is probably from a goblet, and although its country of origin is uncertain it is with all probability from Northern Europe. The rest of the material is almost certainly of English manufacture and from the late sixteenth century (Charleston 1972). The two urinal bases are typical of the ordinary convex based type, with the characteristic external pontil mark. Although this form is static throughout the medieval period these can be dated by association to other material to the sixteenth century (Thorpe 1961: 83). Both the beaker rim and the flask neck are of types already fully discussed in relation to the excavations at St. Peter's Street. The glass represents the type of glass being used on the site, although none of the fragments can be assigned to a particular depositional context and are probably part of the residual make up of the site.

d) Canons Ashby

The excavations from the town of Northampton produced little soda glass, with thirty six out of the forty four vessels found being of forest glass, which were probably made in England. This could lead to the suggestion that soda glass was not extensively used in this area of the country. However a number of sites around Northampton have produced good groups of sixteenth century glass. Canons Ashby was chosen to illustrate this point as it is a site that has been published, but with little reference to its good collection of both soda and forest glass from very partial excavations in 1973 (Taylor: 1974).

The site is situated on the road between Northampton and Banbury and was a priory of the Augustinian order, figure 32. After the dissolution the priory was converted into a residence for Sir John Cope, but after his death in the 1580s it decayed, until by the latter half of the seventeenth century it was subdivided into two rather poor farm houses' (op. cit. 57). In 1970 there was undertaken a limited rescue excavation in the west corner of the monastic south range, where the area was stripped to the post medieval floor levels, figure 33.

Figure 32- Canons Ashby General Plan.

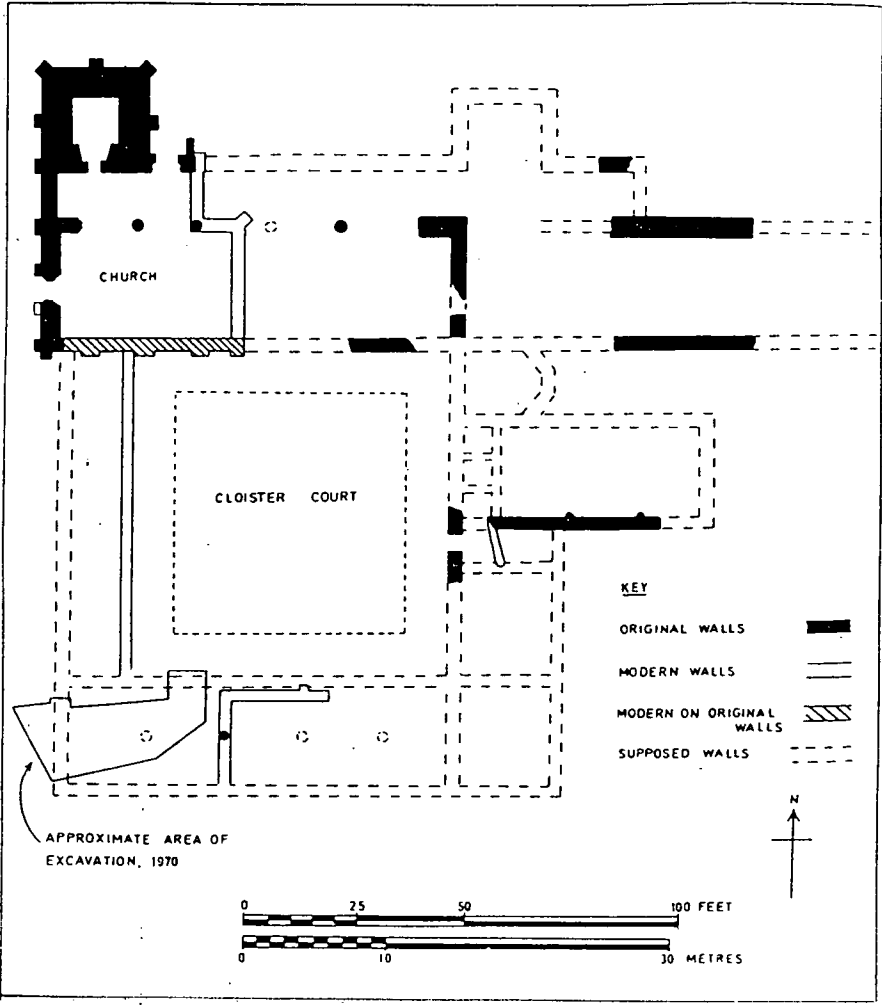
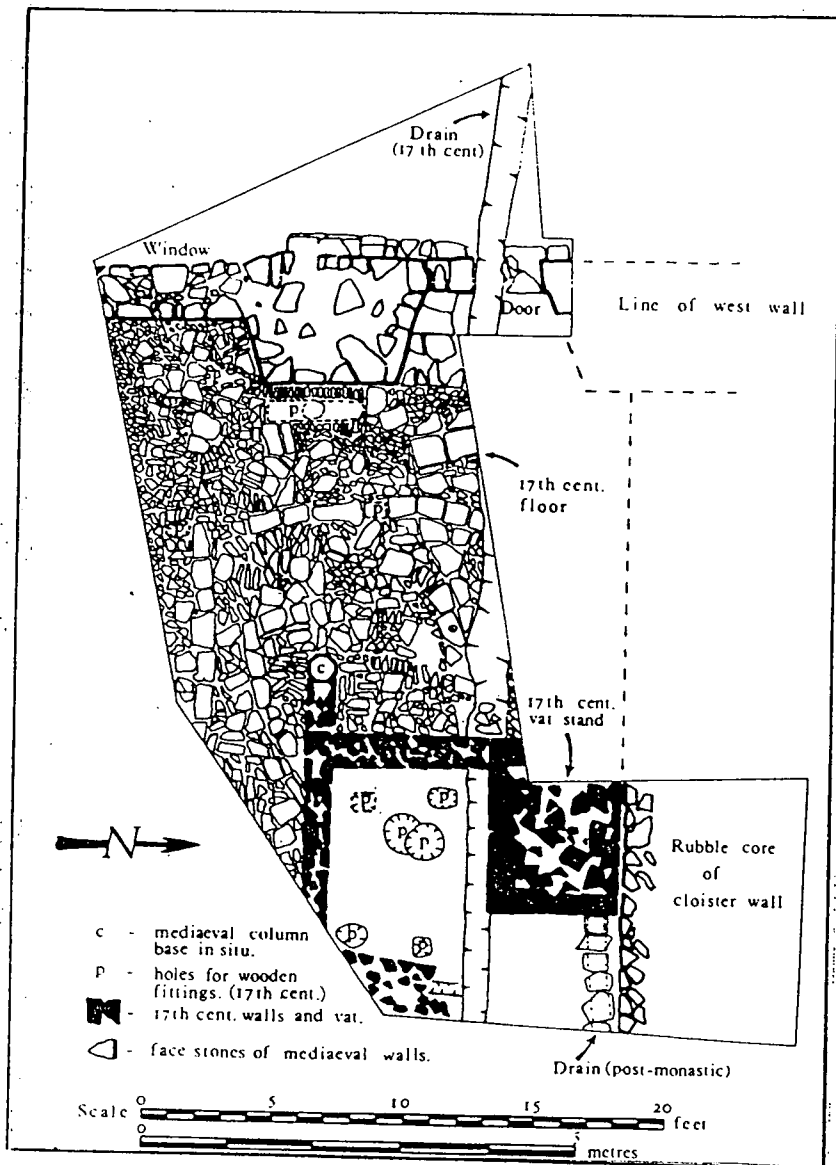

Figure 33- Canons Ashby Excavation Plan.



The excavator reports that a 'few pieces of wine bottles and drinking glasses of a seventeenth century type' were found. He based this on the assumption that the rubble covering the floor he was excavating was from this period. However the glass recovered ranges from mid sixteenth century to very early seventeenth century and represents an important group. This would make the material contemporary with the occupation and decline of the site and might be the result of a clearing out of some of Sir John Cope's glass once he had died. Additionally under the latest medieval floor, on which the rubble and glass was resting, a late sixteenth century Venetian goblet in a relatively complete state was found, and this is the only vessel published by the excavator (Taylor 1974: fig. 2). This was located just under the floor by column 'c' and was only found because this section of floor was lifted in an attempt to ascertain to which floor level this column related.

SF 2a 1 complete base of beaker. Base is pushed in with a low kick and with an applied solid base ring which is rouletted. Decorated with mould blown rounded blobs, only visible under the base. Forest glass, green clear. Little weathering. Base diameter 6.5 cm. Illustrated fig. 34.

SF 4a 1 fragment of body of beaker. Body is vertical sided. Decorated with 6 applied horizontal trails. Forest glass, green. Quite weathered. Body diameter 2 cm. Illustrated fig. 34.

Two beakers of forest glass were found at Canons Ashby. The first is a good quality forest beaker and is of a form that is probably not English. It is very similar to the Dutch *Knoppelbeker* which was produced between around 1575-1625 (Henkes 1994: 137-139). The forest glass metal is of a very high quality and emphasises the problems in differentiating between forest and soda glass. The second beaker is a thin trailed beaker of a poor quality glass and is an English product of around the same period. These thin trailed beakers are found at a number of sites, including Hutton and Rosedale (Charleston 1972: 138). However the remains of two soda glass beakers were also found at Canons Ashby.

SF 2b 1 fragment of body of beaker. Body is vertical sided. Decorated with two bands of trails. Each band consists of one opaque blue trail with an opaque white one either side. Trails marvered slightly into the body. Soda glass, clear. Little weathering. Body diameter uncertain. Illustrated fig. 34.

Figure 34- Canons Ashby Glass.

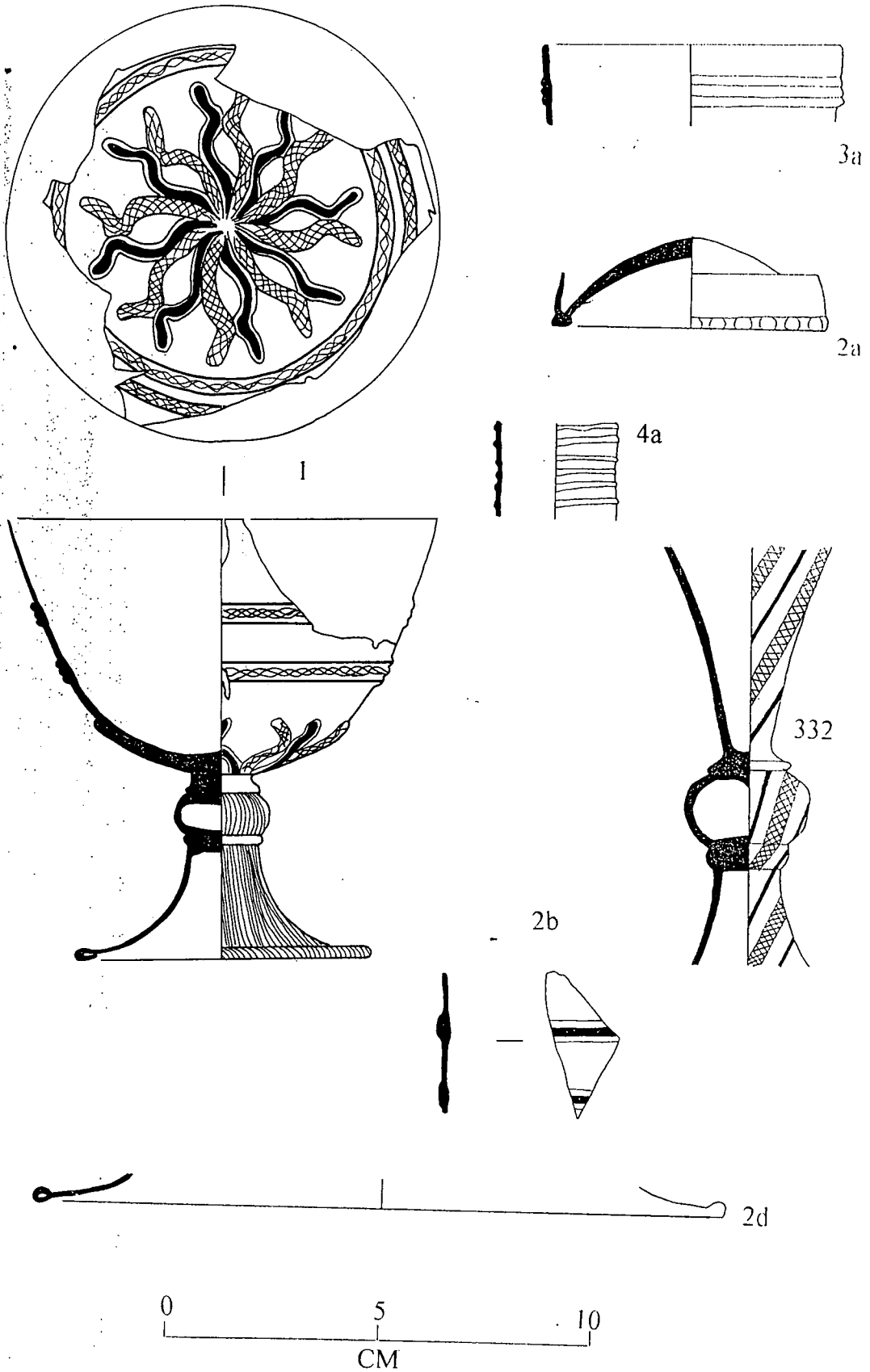

SF 3a 1 fragment of rim of beaker. Rim is vertical sided. Decorated with a band of three horizontal clear trails one cm below the rim.
Soda glass, clear. Little weathering.
Rim diameter 7 cm. Illustrated fig. 34.

These fragments represent two different beakers. The first, SF 2b, is a small fragment from a Venetian or Dutch imported vessel from the second half of the sixteenth century as this blue and white horizontal banding is not found on English vessels in this period (Tait 1991: 168-170). The fragment is too small to identify its exact form, but it possibly came from a straight sided beaker with a simple pushed in base (Henkes 1994: 176). The second fragment of beaker is harder to identify. It is an import but is not characteristic of any Northern European forms. It would seem to be most likely, given the presence of other Venetian or Dutch soda glass, that this fragment is of this origin too.

SF 332 1 large fragment of knob, lower bowl and upper stem of a goblet. Vessel made in three sections, base, knob and bowl then joined. Knob is rounded, plain and hollow, whilst the base and the bowl are concave sided and trumpet shaped. The whole vessel is decorated with a marvered *lattimo* decoration, of alternating plain and twisted opaque white trails.
Soda glass, clear. Little weathering.
Knob diameter 3 cm. Illustrated fig. 34.

These are the only fragments of a goblet from the site and is a Venetian import from the latter half of the sixteenth century when such *lattimo* decoration was popular (Tait 1979: 70 no. 93). This form of goblet is uncommon in England, usually associated with higher status sites, such as a nearly identical example from Acton Court associated with the visit of Henry VIII (Courtney 1991: 125). Often such vessels were lidded (The glass examined from Colchester in Chapter six contains the example of a strip *lattimo* lid fragment) although this is not always the case. Three other vessels also came from the same area as these beakers and flasks.

SF 2d 1 small fragment of base of flask? Base is flaring with a fine folded over base ring. Not decorated.
Soda glass, clear. Little weathering.
Base diameter 16 cm. Illustrated fig. 34.

SF 129 1 small fragment of base of flask. Base has a folded over base ring fragment. Not decorated.
Forest glass, green. Weathered.
Base diameter 10 cm. Not illustrated.

SF 4b 1 small fragment of thick tubing. Possibly from an alembic spout.
Forest glass, green. Weathered.
Not illustrated.

The first fragment listed here is from a very large base, which is assumed to be from a flask. Its form is not distinguishable from this one fragment alone, as its origin is uncertain. The second flask of forest glass is of a more ordinary variety that occurs on sites in the later sixteenth and early seventeenth centuries, often decorated in mould-blown wrythen ribbing (Charleston 1984: 34). The final fragment of tubing is probably from an alembic used to distil spirits and medicines, most commonly found on monastic sites in the fourteenth and fifteenth centuries. They were increasingly used in the seventeenth century, but given the wider context of the site this fragment is almost certainly residual material (op. cit.: 36-37).

The only vessel to be published in the report on this site is the Venetian goblet found under the floor level, figure 36 (Taylor 1974: 64 fig. 3). This vessel is nearly complete and presumably was virtually whole when deposited.

CA 1 Several fragments making complete profile of goblet. Rim is slightly everted with a convex deep bowl. Stem consists of a separate hollow blown knop. Base is flaring with a folded under base ring and distinct pontil mark. Bowl is decorated with 2 horizontal bands of twisted *lattimo* canes and also 16 wriggled bands of twisted *lattimo* decoration radiating from the apex of the bowl. Knop and base are decorated with very fine vertical *lattimo* strands.

Soda glass, clear. Little weathering.

Rim diameter 10 cm, base diameter 7 cm, height 10.2 cm. Illustrated fig. 34.

This vessel dates from around the end of the sixteenth century and is contemporary with the knopped goblet fragment SF 332. This is a vessel of the highest quality and represents a high status object. Similar vessels are known from other high status contexts, Acton Court (Courtney 1991: 125) as well as from Venice itself (Tait 1979: 70 no. 93).

Canons Ashby has been used to provide a contrast with the material found on excavations within Northampton itself. The city excavations have produced little soda or imported glass and it could be seen as an indication that material of that quality was not available in this area. However the glass found from the limited excavation at Canons Ashby provides a broader picture of vessel glass and its distribution. Clearly in the urban areas investigated in Northampton this type of quality soda glass was not

being extensively used. However rural sites such as this help to demonstrate that glass of this quality was in use in this area of the country. The lack of this material in the centre of Northampton might have more to do with the position and status of the urban dwellers rather than the location of the town itself.

Chapter 6- Colchester

Colchester was Roman town Colonia Claudia Victricensis, being the first capital in Britain shortly after the Roman conquest in 43 A.D. By the medieval period Colchester still occupied the former site of the Roman town, taking many of its boundaries from the earlier walls. These were built upon in the twelfth and thirteenth centuries to create the medieval town defences. Between the fourteenth and the sixteenth centuries Colchester emerged as an expanding commercial centre, becoming one of the dozen wealthiest towns in the kingdom, mainly benefiting from trade with Northern Europe (Britnell 1986: 4-5). Numerous excavations have been undertaken by the Colchester Archaeological Trust in the 1970s and 1980s prior to extensive redevelopment, figure 35. These excavations generally concentrated on Colchester's Roman past, particularly centred on the Boudican levels with the consequence that much vital information on its important medieval and early modern phases has been lost. However a considerable amount of glass has been recovered from Colchester from sixteenth century contexts and five of these groups are investigated here.

a) Middleborough

The excavations in the Middleborough area of Colchester were undertaken in 1979 and revealed features from the Roman period to the present day. Two medieval buildings were discovered along the old road frontage and these were occupied into the early modern period, figure 36 (Crummy 1984). A small but important group of glass was recovered from these tenements from apparent pit features, but due to the confused nature of the excavation the artifacts can not be assigned to published features. However the two sixteenth century buildings were recovered which were quite substantial. Both had a central hall with a north and a south wing, the southern wing containing evidence for service rooms. The north wing of building 76 still retains its superstructure, whilst its southern wing joins the northern one of building 75, with

Figure 35- Colchester Location Plan.

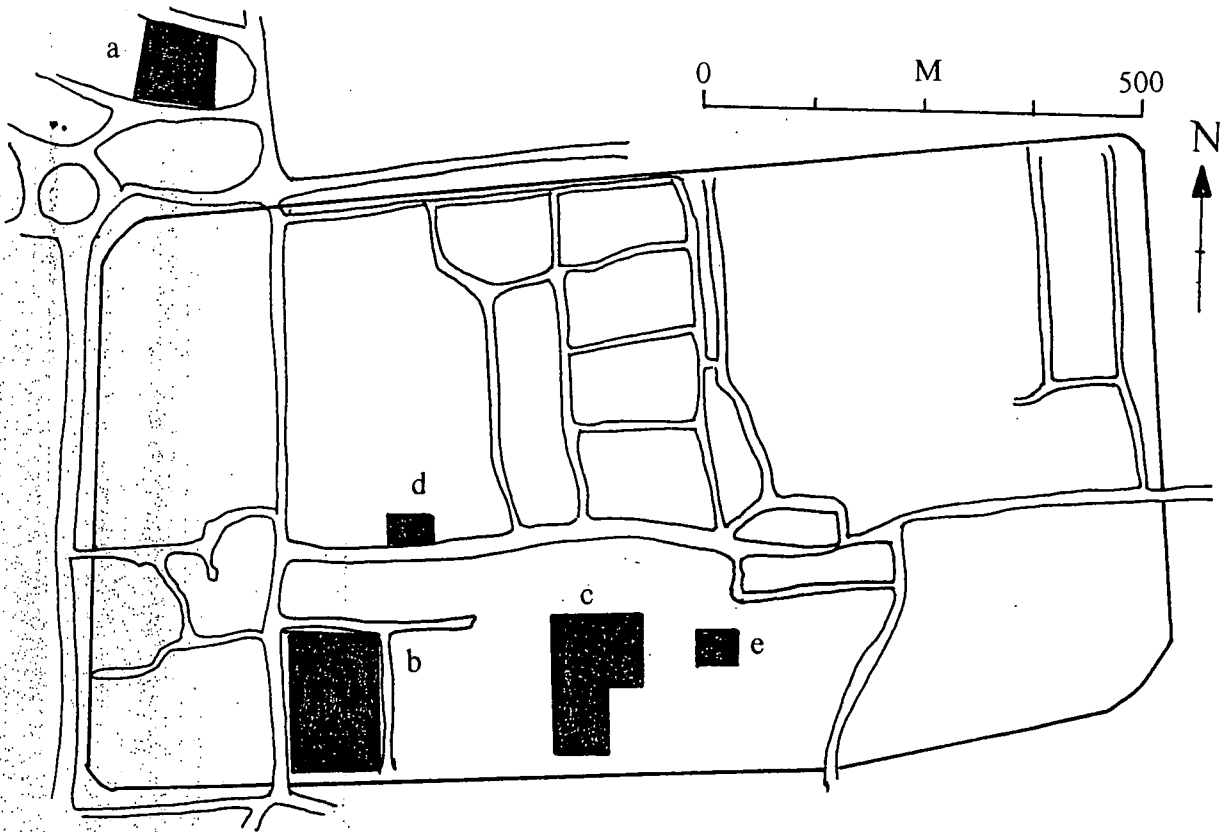

- a: Middleborough
- b: Lion Walk
- c: Culver Street
- d: Cups Hotel
- e: Long Wyre Street

Figure 36- Middleborough Plan and Glass

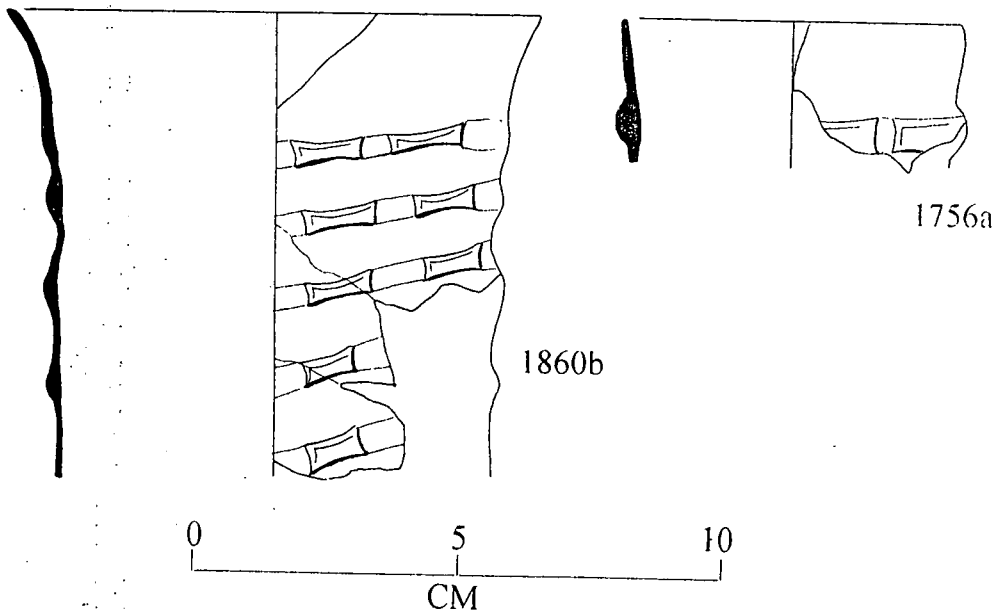
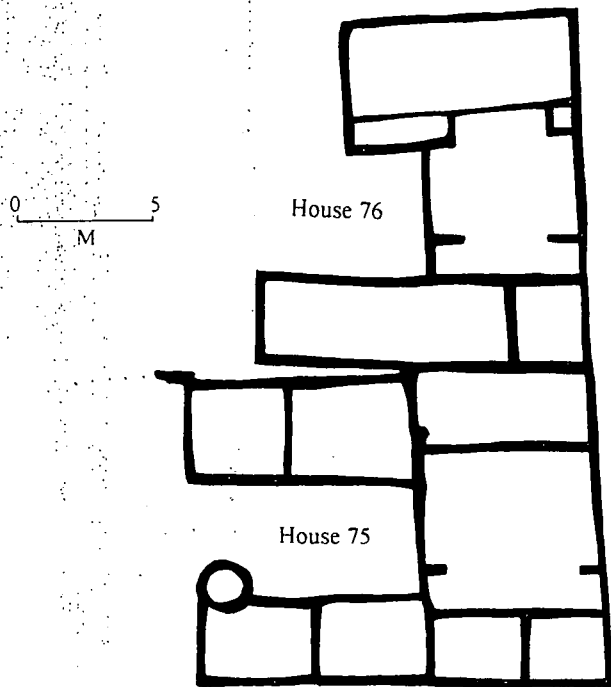

both these properties having back yards (Crummy 1984). The remains of five to six vessels were recovered and all but one of these were beakers.

SF 1860b 3 fragments of rim and 4 of body, joining, of beaker. Rim is everted and body vertical sided. Decorated with the remains of five bands of an applied cut spiral trail.
Soda glass, clear. Little weathering.
Rim diameter 10 cm. Illustrated fig. 36.

SF 1756a 1 fragment of rim of beaker. Rim is vertical rim and body straight sided. Decorated with one band of cut spiral decoration.
Soda glass, clear. Little weathering.
Rim diameter 6.5 cm. Illustrated fig. 36.

SF 1862 1 large fragment of body of beaker. Rim is vertical. Decorated with bands of cut spiral trail.
Soda glass, clear. Little weathering.
Body diameter 9 cm. Not illustrated.

SF 3025 1 small fragment of body of beaker. Body is vertically sided. Decorated with the remains of two bands of cut spiral trail.
Soda glass, clear. Little weathering.
Body diameter 8-9 cm. Not illustrated.

SF 1756 1 small fragment of rim of beaker. Rim is vertical. No decoration.
Soda glass, clear. Little weathering.
Rim diameter 10 cm. Not illustrated.

The first four of these beakers are *Wafelbekers* and imported from the Low Countries and probably produced in Antwerp. They were produced in the second half of the sixteenth century and continued, varying slightly in form, into the seventeenth century (Henkes 1994: 129-136). The first vessel, SF 1860b, is typical of the earlier variety with the everted lip, and the body fragments, SF 1862 and SF 3035, probably belonging to very similar vessels. The second rim, SF 1756a, is not everted but vertical and this is probably from an early seventeenth century example (op. cit.: 138, no. 30.8). This rim is also narrower and comes from a taller thinner vessel than the earlier squatter examples. The final rim fragment, SF 1756, is also plain and vertical, although there is not enough of the body left to tell if this too had the characteristic cut spiral decoration of a *Wafelbeker*. The only other vessel fragment found was a bottle.

SF 1860a 1 fragment of rim and 5 of body of square bottle. Rim is everted and with a short neck. Body is thin blown and square. Forest glass, green clear.
Rim diameter 2.75 cm. Body diameter 7 x 7 cm. Not illustrated.

This is a typical small example of an early case bottle dating to the end of the sixteenth century (Charleston 1972: 145). It is unremarkable in itself, although the group of glass as a whole is very important. The deposits at Middleborough produced a very interesting ratio of vessels, with five out of the six vessels being imported *Wafelbekers*. This represents a small but significant drinking group that seems to have been deposited around the turn of the sixteenth century. It would be rash to view this as a matching 'set' of vessels, but it does appear that in this household all the beakers used were of the same imported variety. There is no evidence for the more common English forest beakers that are more usually associated with sites such as these (Charleston 1984: 87). The building from which these vessels came, is of a higher status, being a hall with two wings, and possibly belonged to someone of a mercantile class. Perhaps this represents the deposition of a table service, where there was a uniformity of vessels used, in this case all being imported from the Low Countries (Henkes 1994: 129-136).

b) Lion Walk Areas 'B' & 'K'

The excavations at Lion Walk took place between 1971 and 1974, with area 'B' being dug in 1971 and 'K' in 1972, figure 37 (Crummy 1984). The excavations were undertaken to primarily examine the pre-Boudican levels of Colchester's Roman archaeology and this is reflected in the very poor recording of the features and material of this site from later periods. Area 'B' is the worse recorded, with almost all of the glass without a context, whilst the glass from area 'K' appears to come from two pits that are allotted contexts during excavation, but are ignored subsequently (op. cit. 73). Neither site produced evidence for an actual structure dating from the late medieval or early modern periods, although the material culture suggests that activity was going on in this area of Colchester. Much of the material had clearly been machined from the site and recovered later, with many of the breaks in the glass being un-weathered and therefore recent. Consequently it is probable that much of the glass

Figure 37- Lion Walk Plan.

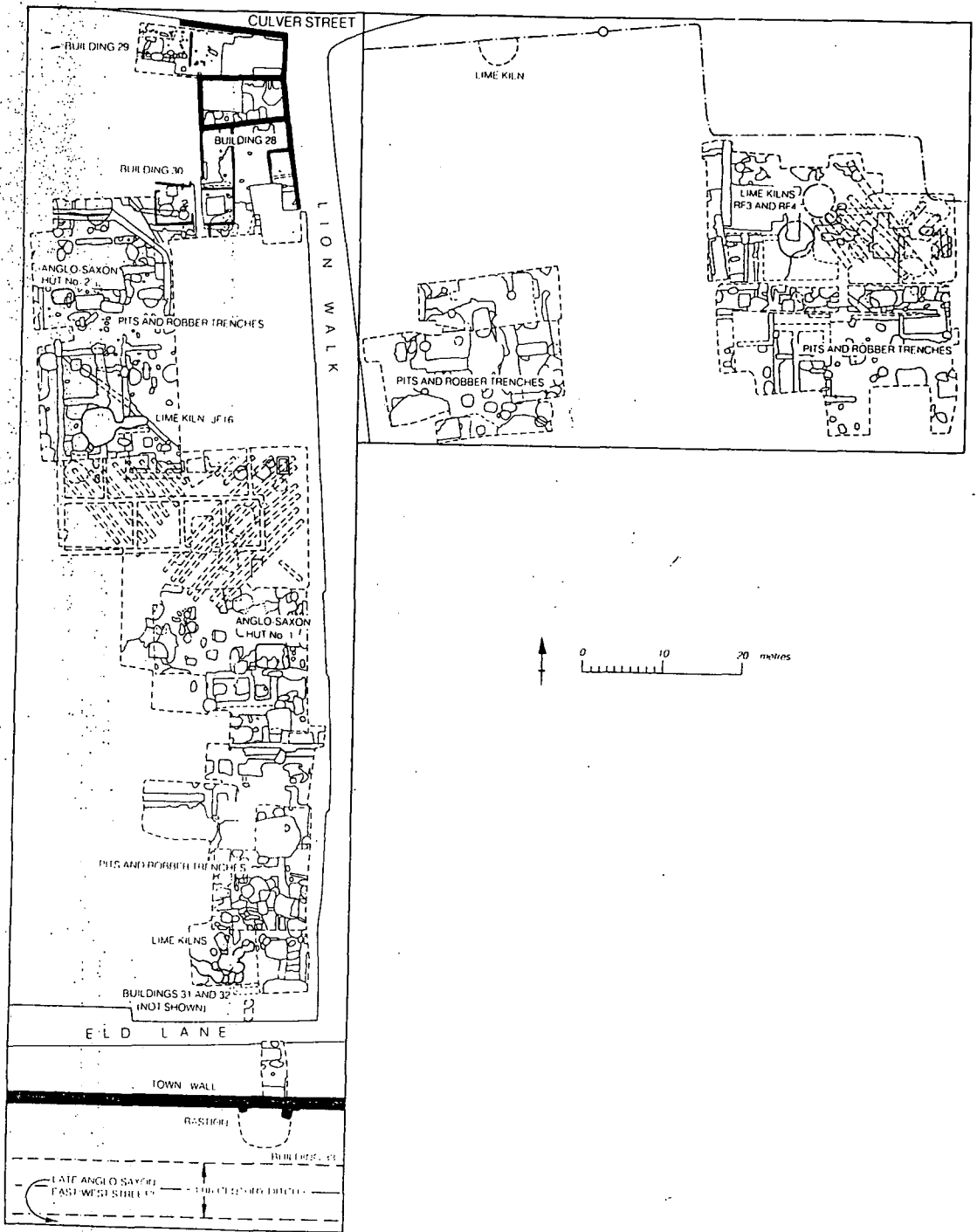

has been lost and it is thus quite hard to interpret the remainder. However the glass that remains is clearly important and deserves attention and examination.

AREA 'B'

Area B lies in the northern part of the excavations, just off the street frontage of the eastern side of Lion Walk, figure 37. The area in the sixteenth century period is purely recorded as "pits and robber trenches" in the excavation report (Crummy 1984: 74). It is assumed that the glass came from some such pit and was from a building on or near the site which the excavations did not detect. Eight vessels were recovered in all.

SF 333 1 fragment of rim and upper body of beaker. The rim is everted and the upper body is vertical. Body is decorated with the remains of one row of cut spiral trailed decoration. Soda glass, clear. Some weathering. Rim diameter 10 cm. Illustrated fig. 38.

SF 12 1 small fragment of body of beaker. Body is convex. Decorated with an applied pointed prunt. Soda glass?, blue/green clear. No weathering. Illustrated fig. 38.

These two beakers, although both very different, are probably from the Low Countries. The first is an earlier *Wafelbeker* with a wide everted rim and spiral decoration as already described at Middleborough. The second, an applied prunted vessel is a *Berkemeier*, the forerunner of the *Roemer* (Henkes 1994: 189-196). This would have had a wide everted rim and upper body, which was half the height of the vessel, and tapered to a narrow cylindrical lower body and base. It was its lower body that was decorated with two or three rows of prunts. This type of beaker is generally assumed to have been used to consume wine, due to its smaller capacity, whilst the *Wafelbeker* was for beer (Ibid.).

SF 34 1 fragment of top knop of goblet stem. The knop is a solid annular form. Stem type is uncertain. Some evidence for the grozing of the lower bowl fragments. Soda glass, clear. Little weathering. Knop diameter 2.8 cm. Illustrated fig. 38.

SF 17 1 fragment of stem of goblet. Stem is the top half of a two piece mould blown lion mask stem. Decorated with the upper tear drop decoration and the start of the lion's face (see illustration). Soda glass, clear. Little weathering. Illustrated fig. 38.

Figure 38- Lion Walk area 'B' and 'K' pit F15 Glass

Area 'B'

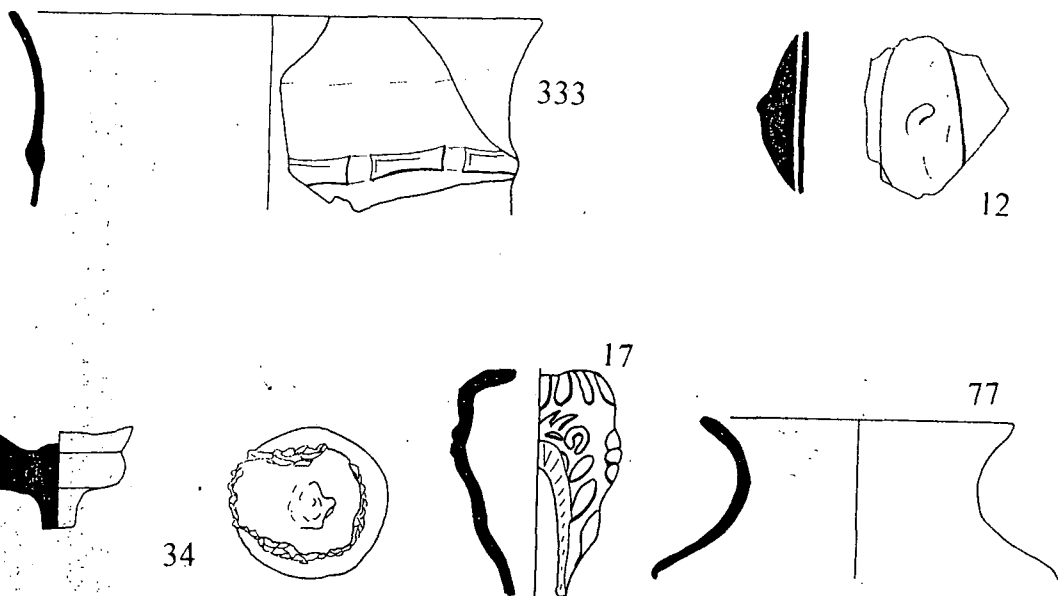

0 5 10
CM

Area 'K' pit f15

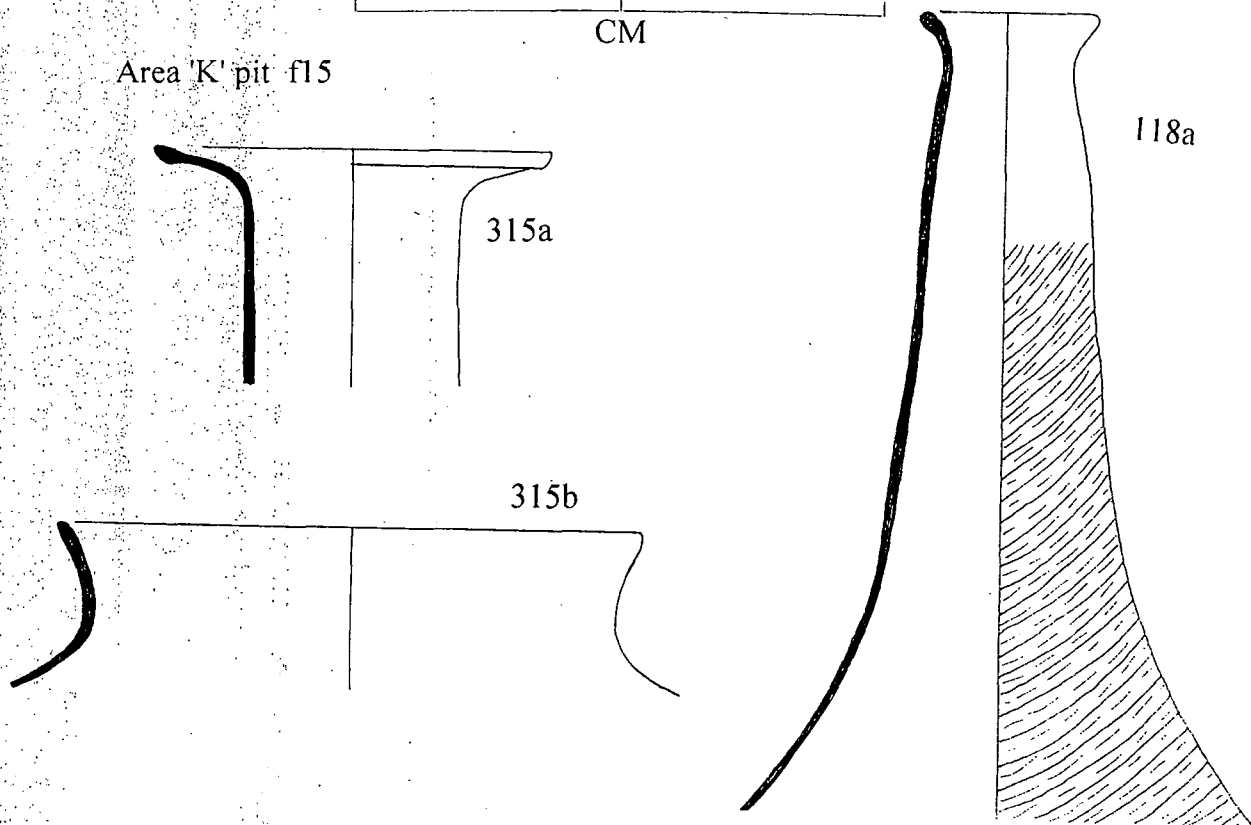

The first fragment is from the upper annular knob which joins the goblet stem to its bowl (Some early seventeenth century examples are illustrated in Thorpe 1961: 131). Unfortunately not enough survives of the stem to tell what form it took. However it appears that broken fragments of the lower bowl from the stem have been intentionally broken off or grozed. It is not apparent what purpose this might have served, although it is possible that this is the result of some very unusual weathering and fragmentation that took place in the soil. The second fragment of a goblet is also part of a stem. It is a mould blown lion mask stem, although it is broken in such a fashion as to obscure most of the masked decoration. This is probably an English type and dates from around the end of the sixteenth century, given the context of the other glass (Charleston 1984: 59). Unfortunately at the moment it is not possible to accurately source or date these stems, which are found all over Europe between around 1550 and 1650 (Ibid.).

SF 77 1 fragment of rim of jar. Rim is everted and with a concave upper shoulder. Not decorated. Forest glass, green clear. Some weathering. Rim diameter 6 cm. Illustrated fig. 38.

This is the only jar fragment from this area of Lion Walk, which contrasts with the other material found at area 'K'. It is of an ordinary late sixteenth or early seventeenth form and probably used in a domestic setting (Charleston 1984: 92-93).

SF 316 1 fragment of neck of flask. Neck is straight sided and slightly tapers out. Decorated with mould blown wrythen decoration running from top right to bottom left. Forest glass, green. Medium weathering. Not illustrated.

SF 70 3 fragments, joining, of base of flask. Base is pushed in with low kick and large pontil mark. Not decorated. Forest glass, green. Weathered. Not illustrated.

These final two sets of fragments are the remains of one or two flasks. These both are of an ordinary forest type, with a pushed in base and decorated with wrythen ribbing. These are probably both English and are typical of the late sixteenth century (Charleston 1972: 145). Area 'B' also produced the remains of a nearly complete large case bottle, although unfortunately it is unstratified, figure 39.

Figure 39-Lion walk Case Bottle

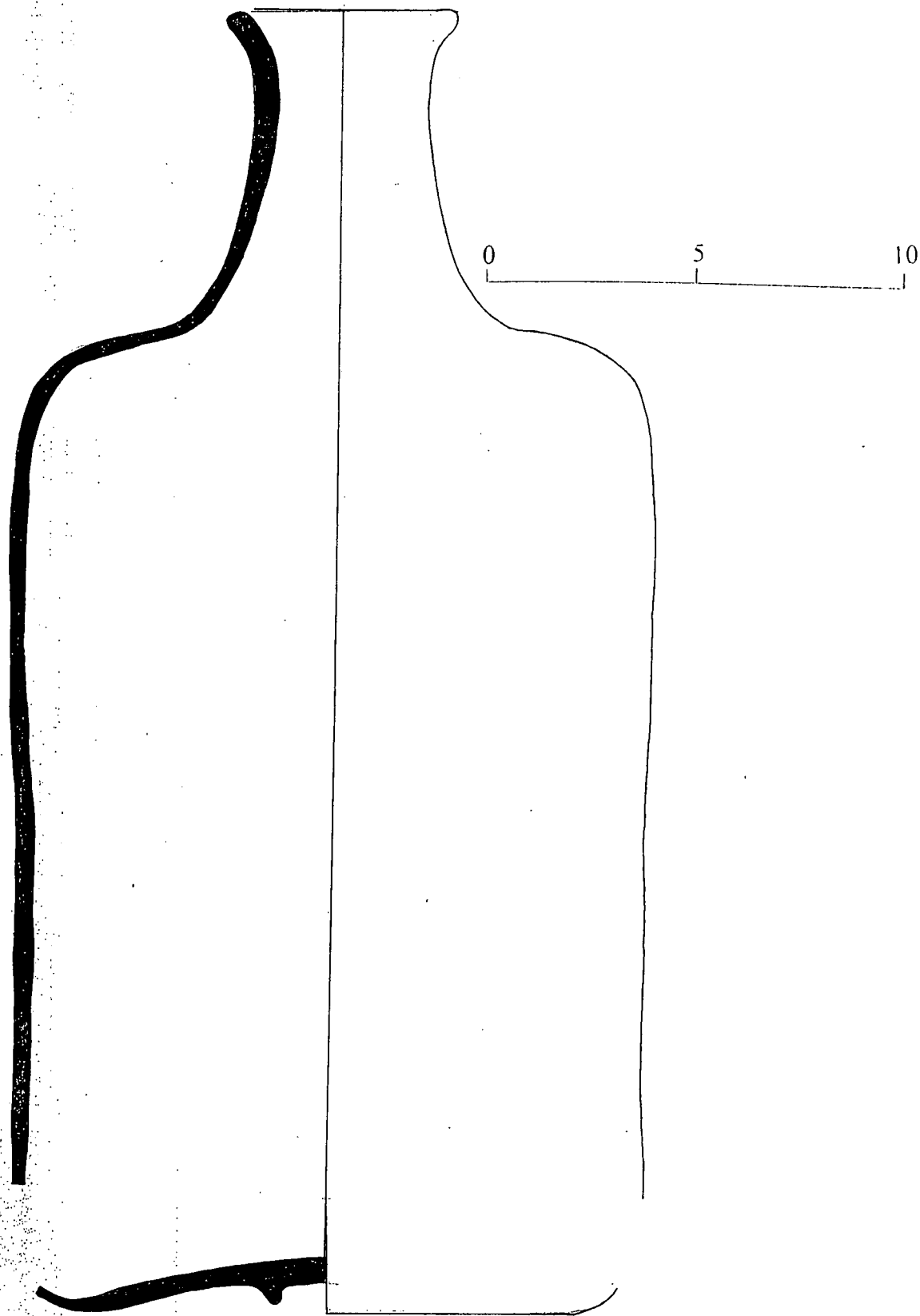

Unstrat 6 fragments, joining, of rim body and base of square case bottle. Rim is everted with a vertical neck which joins the straight sided body with a sharply convex shoulder. Base is slightly pushed in with a very distinct cracked off pontil mark. Not decorated.

Forest glass, green clear. Little weathering.

Rim diameter 5.2 cm, base 12 x 12 cm, height 30.4 cm. Illustrated fig. 39.

This vessel is of typical form, with an everted rim, a tapering neck and a square section body. However it is the base that is important on this example, being of almost identical form to the case bottle bases from Winchester, chapter 3. This base is slightly pushed and has a very distinct cracked off pontil mark. When this is compared to the Winchester examples, figure 14, they can be clearly seen to be from the same type of vessel.

The Winchester fragments are from a sixteenth-century context, and although the Colchester example is unstratified it is probably of a similar date. This case bottle is of a slightly better quality metal, so might date from the first quarter of the seventeenth century. Nevertheless it is clear that large capacity case bottles were being produced by 1600, this example having an approximate volume of 6.75 litres or 11.5 pints.

The glass from Lion Walk site 'B' is a small but interesting group. The two beakers found are both from the Low Countries and were seemingly popular products in Colchester. The two goblet fragments however are more likely to be English, neither style being particularly common in Holland (Henkes 1994: 189-196). The site also produced the remains for a couple of flasks, making the whole group quite representative of the variety of glass forms in use in the late sixteenth century. It is probable that they were all deposited at once and were from a domestic dwelling in the immediate area. They also make a marked contrast with the deposit from area 'K' in Lion Walk, which does not produce such a wide range of domestic glass.

AREA 'K'

Area 'K' was excavated in 1972 and lies in the southern part of the Lion Walk excavation, figure 37. As with area 'B' no structures of the medieval or early post medieval period were found, although a number of pits were from this period were

excavated. Two pits from this area produced quantities of glass, f15 & f125, although the glass was generally of a different nature than that from area 'B' and Middleborough (Crummy 1984).

PIT f 15

SF 315a 4 fragments, joining, of rim of urinal. Rim is broad and everted with slight upturn on the edge. Not decorated. Forest glass, green clear. Little weathering.
Rim diameter 8 cm. Illustrated fig. 38.

SF 315b 3 fragments of rim of jar. Rim is wide and everted, curving to a shoulder. Not decorated. Forest glass, green. Some weathering.
Rim diameter 11 cm. Illustrated fig. 38.

SF 118a 15 fragments, joining, of a rim, neck and shoulder of a large flask. Rim is everted, neck vertical with slight outward taper. Shoulder is convex. Decorated with a faint mould blown wrythen running from top right to bottom left.
Forest glass, green clear. Little weathering.
Rim diameter 4.6 cm. Illustrated fig. 38.

SF 118b 1 fragment of base of flask. Base is broad and pushed in, with a shallow pointed kick. Not decorated. Forest glass, green. Little weathering
Base diameter uncertain. Not illustrated.

SF 118c 2 fragments, joining, of base of flask. Base is pushed in with a wide kick. Not decorated. Forest glass, green. Some weathering.
Base diameter 6.5 cm. Not illustrated.

The contents of this pit comprised of five forest glass vessels. The first, SF 315a, is a typical urinal rim, broad, everted and with a slight upturn on the edge of the rim. This type of vessel is usually assumed to be of English origin and from the second half on the sixteenth century (Charleston 1984: 33). Likewise the jar rim fragments, SF 315b, are from a late sixteenth century vessel and are probably English (op. cit.: 92-93). The three flasks are of the common pushed in base variety and with at least one showing faint wrythen decoration. The whole group represents a collection of ordinary forest glass, deposited possibly in a domestic rubbish pit, although it is unusual to find no evidence of any drinking vessels. It is likely that the contents of this pit had its same origins as the second pit f125, that being from an apothecary.

PIT F 125

SF 1 1 large fragment of rim and body of beaker. Rim and body vertical and straight sided. Decorated with mould blown vertical fluting with upper hexagonal pattern of three rows below the rim. Forest glass, clear with green tint. Very weathered.
Rim diameter 6.5 cm. Illustrated fig. 40.

Figure 40- Lion Walk Area 'K' pit F15 & F125.

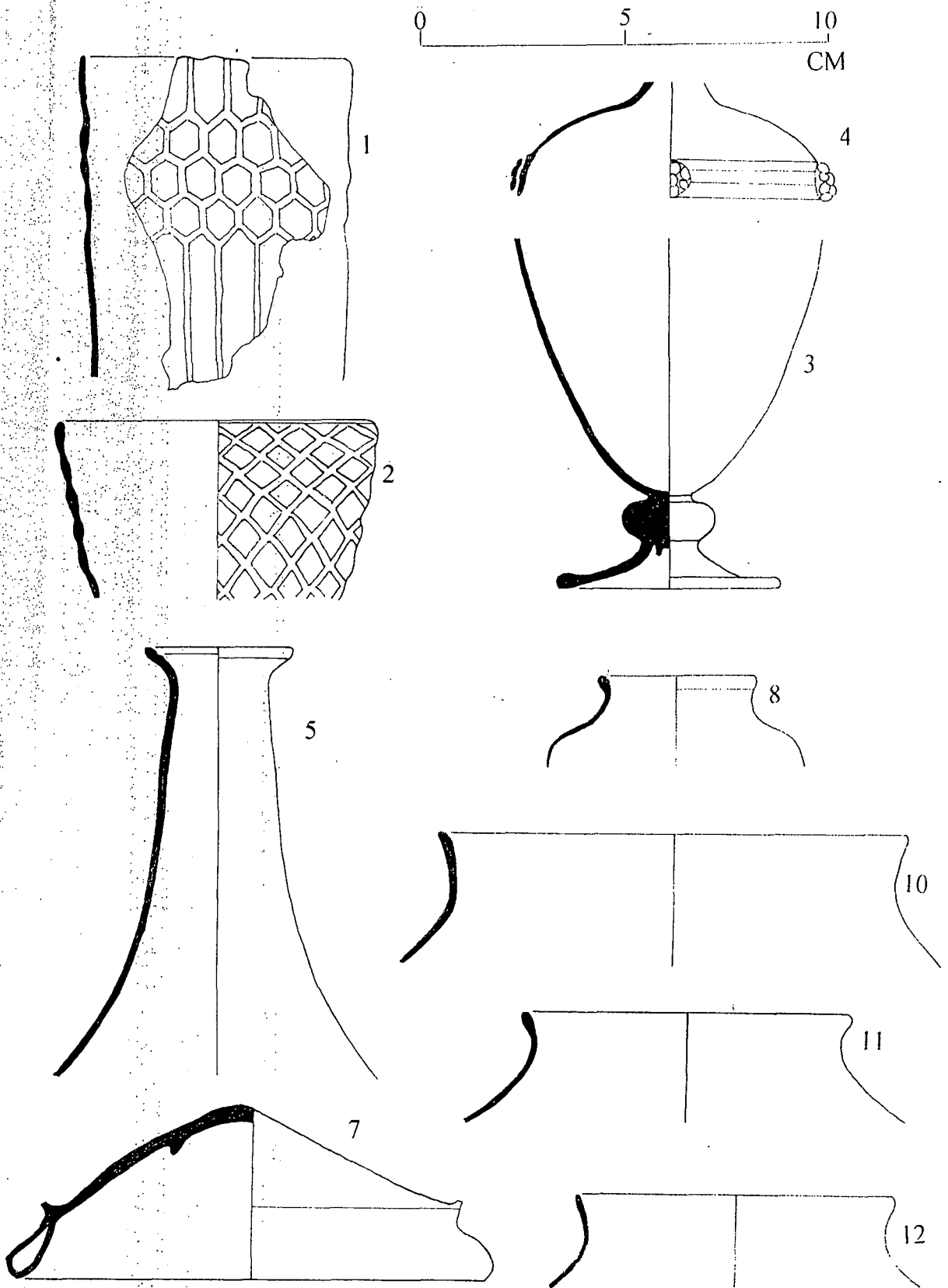

SF 2 2 fragments of the rim and bowl of goblet. Rim is slightly everted and bowl curving and convex. Decorated with mould blown heavy diamond pattern all over the vessel.
Forest glass, clear, green tint. Some weathering.
Rim diameter 7.5 cm. Illustrated fig. 40.

SF 3 Several fragments, joining, of base, stem and bowl of goblet. Base is narrow and flaring joined to a large solid stem knob. Bowl is deep and convex sided. Distinct narrow pontil mark under the base.
Soda glass, clear. Quite weathered.
Base diameter 5.5 cm. Illustrated. fig. 40.

SF 4 4 fragments of lid of goblet. Lid is convex and tapers up to a finial, now lost. Lower lid is decorated with bands of horizontal decoration and the remains of two applied rosette prunts.
Soda glass, clear. Some weathering.
Lid diameter 7.5 cm, illustrated fig. 40.

These fragments of four vessels are the only drinking receptacles found from this large deposit of glass. The first two are ordinary forest products, although the beaker has an unusually complex design. The vessel of real interest from this group is the goblet, and the lid, which is possibly related to it. This squat footed goblet, with its rather narrow base, is an unusual form and without direct parallel. It is most similar to goblets produced in the Low Countries which are made in two pieces, although these are more usually decorated with mould blown designs (Henkes 1994: 186) The lid, in a similar fashion, can not be directly compared to any known example, its rough form is similar to twisted cane *lattimo* examples, although without the folded shoulder, which might be missing (op. cit. 177 no. 41.13). None of these known lids have this applied rosette and thus this vessel is uncertain in both date and origin. However the rosette design is similar to those found on some of the Low Country beakers, possibly suggesting Antwerp as an area of manufacture (Henkes 1994: 134) The rest of the glass from this context is more common place and easier to identify.

SF 5 Several joining fragments of the rim and neck of a large flask. Rim is everted and the neck straight and tapering outwards. Decorated with mould blown wrythen ribbing starting 4 cm below the rim, running from top right to bottom left.
Forest glass, green. Little weathering.
Rim diameter 3.3 cm. Illustrated fig. 40.

SF 6 Several joining fragments of rim and neck of flask. Rim is everted and neck straight and tapering out to the shoulder. No decoration.
Forest glass, green. Quite weathered
Rim diameter 3.4 cm. Not illustrated.

SF 7 2 large fragments, joining, of base of flask. Base is pushed in pedestal with high kick and distinct pontil mark and large folded base ring. No decoration.

Forest glass, green. Weathered.

Base diameter 11.3 cm. Illustrated fig. 40.

These three fragments represent the remains of two or three large flasks. One is covered with wrythen decoration and these vessels would have been used to contain large quantities of liquids. These are ordinary finds in domestic settings but in conjunction with the other vessels from this context suggest a different function.

SF 8 1 large fragment of rim and shoulder of jar. Rim is everted with a concave neck leading to a rounded a sharp angled shoulder. Not decorated.

Forest glass, green clear. Little weathering.

Rim diameter 3.7 cm. Illustrated fig. 40.

SF 9 2 fragments, no join, of rim and neck of jar. Rim is everted with a concave neck. Not decorated.

Forest glass, green. Some weathering.

Rim diameter 11 cm. Not illustrated.

SF 10 1 fragment of rim and neck from jar. Rim is everted with concave neck. Not decorated.

Forest glass, green. Some weathering.

Rim diameter 11.4 cm. Illustrated fig. 40.

SF 11 3 fragments of rim and neck from jar. Rim is everted with a concave neck. Not decorated.

Forest glass, green. Some weathering.

Rim diameter 7.8 cm. Illustrated fig. 40.

SF 12 1 fragment of rim and neck of jar. Rim is everted with a concave neck. Not decorated.

Forest glass, green. Some weathering.

Rim diameter 7.5 cm. Illustrated fig. 40.

SF 13 1 small fragment of rim of funnel? Rim is very widely everted rim with a sharply tapering in body. Decorated with one trail both internally and externally.

Forest glass, green. Quite weathered.

Rim diameter 14.5 cm. Not illustrated.

The remainder of the vessels from this pit were all of forest glass, five being jars and the sixth a possible funnel. This is a very high proportion of jars for an ordinary context and coupled with the scarcity of drinking vessels suggests that this deposit is not an ordinary domestic one. This indeed would fit in with the remains from the vessels used in an apothecary. Jars such as these were well known in such settings and were often illustrated in such (Charleston 1984: plate 17a). This would concur with the documentary evidence gathered by John Cotter (Cotter Pers. Com.). A family of apothecaries were documented to have been working in Lion Walk, the first Thomas Buxton, 1549-1607, and the second his son Robert, 1577-1655. It would seem that this pit can be related to this family operating in this part of Colchester, and most

probably to the first of that family, Thomas Buxton. In addition to the glass a total of seventy seven *Alberelli*, or pottery drug jars, were recovered from this area of the excavation. These were mainly imported from Antwerp and the Low Countries (Ibid.).

c) Culver Street

Culver Street was excavated in two stages in 1981 and 1984, in advance of a large shopping precinct being built. The excavation gave priority to the Boudican levels, with even the later Roman period receiving less attention. Only two thirds of the site was actually subject to any archaeological attention at all (Crummy 1992: 1-5). Consequently the medieval and post medieval archaeology was, at best, scantily recorded. However glass was recovered and kept from two areas of the excavation, 'E' and 'A', figure 41.

AREA 'E'

The excavations in this area produced a large quantity of medieval and post medieval pits but no definable structures. This is probably because the excavations took place several metres behind the medieval street front and what is represented is the back gardens of these properties (Crummy 1992: 123-125). As much of the area was very disturbed the contexts of the pits were contaminated. However a few glass fragments were retrieved.

SF 316a 1 fragment of body of beaker. Body is convex sided. Decorated with spiralled trails of alternating blue and opaque white, marvered flat.

Soda glass, clear. Little weathering.

Illustrated fig. 42.

SF 316b 2 fragments, joining, of rim and neck of bottle. Rim everted and neck narrow and vertical. Decorated with mould blown wrythen ribbing.

Forest glass, green. Some weathering.

Rim diameter 1.6 cm. Illustrated fig. 42.

SF 373 1 small fragment of bowl of goblet. Bowl is convex. Fragment from near the stem with eleven thin horizontal trails.

Soda glass, clear. Little weathering.

Not illustrated.

Figure 41 - Culver Street Plan

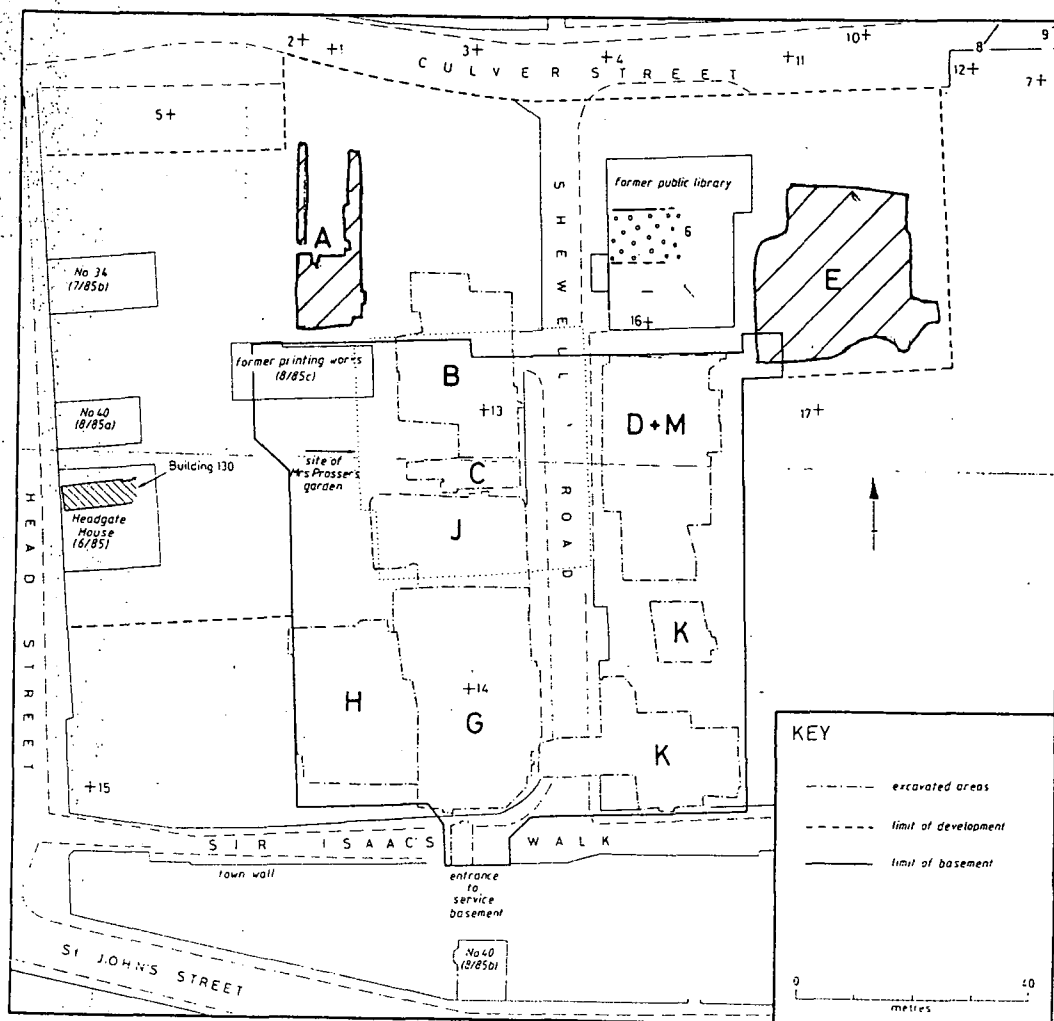

These three fragments are a small group, but they do contain an indication of some of the vessel forms used on this part of the site. The first fragment is from a beaker from the Low Countries, possibly made in Antwerp. This *vetro a fili* beaker is typically decorated with this blue and opaque white trailing (Henkes 1994: 170-172). This is a high quality vessel and would have been an expensive import. The second vessel is an English wrythen decorated bottle, possibly from the second half of the sixteenth century (Charleston 1972: 145), whilst the small fragment of the third goblet is of uncertain origin and date. The second area from the excavations at Culver street produced a far larger group of glass.

AREA 'A'

Area 'A' is similar to the previous area of the site, with there being no evidence of any structures from the sixteenth century surviving. This area was also subject to very poor excavation with many of the pits not even being sampled (Crummy 1992: 123). One pit, F7, was excavated and provided a large group of glass, although not all of the same period.

SF 1 6 fragments of base of beaker. Base is pushed in with a low kick and an applied solid base ring. Not decorated.
Forest glass, green. Some weathering.
Base diameter 5.5 cm. Illustrated fig. 42.

SF 2 3 fragments of base of goblet. Base is flaring with folded base ring. Not decorated.
Soda glass, clear. Little weathering.
Base diameter 5.5 cm. Not illustrated.

SF 3 1 fragment of base of urinal. Base is thick, convex and with an external pontil mark. Not decorated. Forest glass, green. Weathered.
Not illustrated.

SF 4 3 fragments, joining, of base of flask. Base consists of fragments of a base ring from a pushed in pedestal base. Not decorated.
Forest glass, green. weathered.
Not illustrated.

SF 5 1 fragment of rim, neck and handle of jug. Rim is everted with a vertical neck. Handle applied just below the rim and is thick and with an oval cross section. No decoration.
Forest glass, deep green. Heavy weathering.
Rim diameter uncertain. Illustrated fig. 42.

Figure 42- Culver Street Glass.

Area 'E'

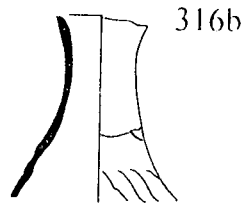
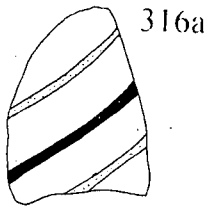

Area 'A'

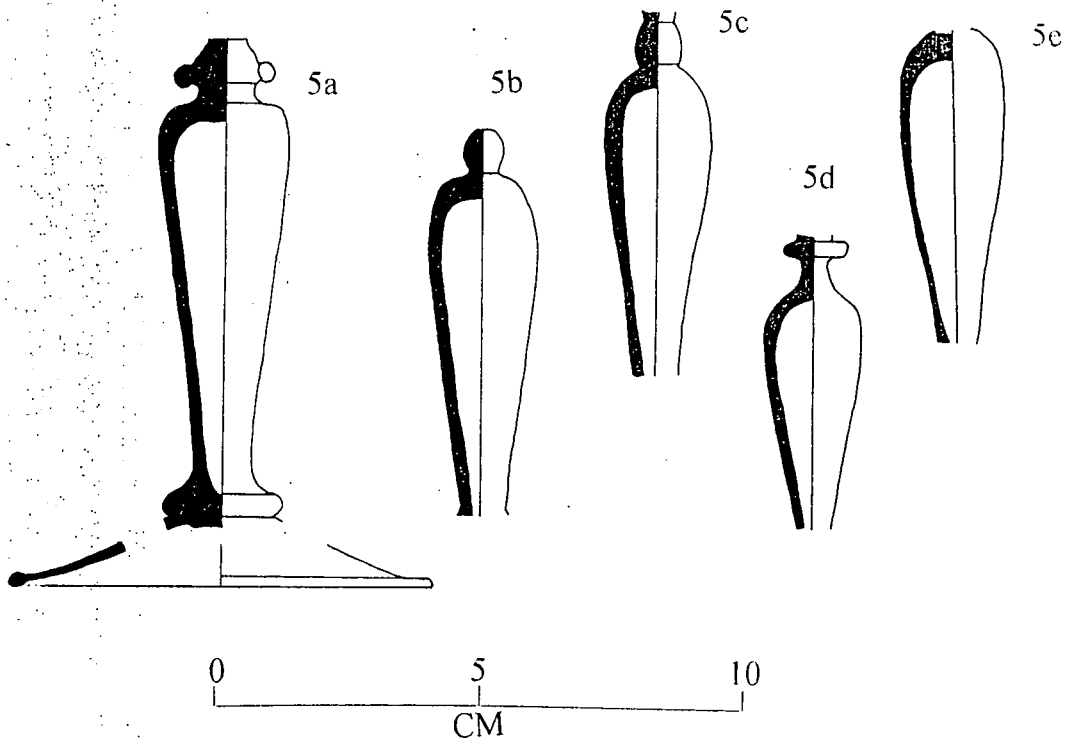
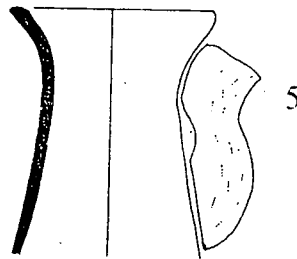
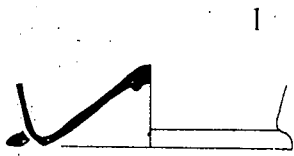

Four of the five vessels from this pit are forest glass and almost certainly from English production sites. The beaker is a typical late sixteenth century form and found at the glass production sites of Hutton and Rosedale (Charleston 1972: 150 fig. 67). The urinal and the flask frequently occur on sites from the fifteenth and sixteenth century contexts, although these are often hard to date stylistically. The fragment of the jug is more unusual, although forms such as this occur in both soda and forest glass (Hurst-Vose 1995: 30). This jug is slightly more peculiar due the very thick applied handle, which seems unnecessarily large for the size of the vessel. The final fragment of a soda goblet base possibly dates from the late sixteenth century but could belong to the first half of the next century, and might be related to the final group of fragments from this pit. These are the remains of five goblet stems and although they date from the first half of the seventeenth century were found in the same context as the sixteenth century material (Thorpe 1961: 170). This could be the result of the earlier material being deposited a long time after it was produced, or that these wine glass stems were deposited in a later cut into the original feature and this was not detected during the excavation.

SF 5a 3 fragments of stem and base of goblet. Stem is an elongated hollow baluster cigar type with a short extension and upper rounded solid knob. Applied spherical prunt on upper knob. Joined to the base by a solid annular knob. The base is flaring with a folded under edge. Not decorated.

Soda glass, clear. Little weathering.

Base diameter 11 cm. Illustrated fig. 42.

SF 5b 1 fragment of stem of goblet. Stem is hollow cigar type, broken before the base join and with an upper solid round knob. Not decorated.

Soda glass, clear. Little weathering.

Illustrated fig. 42.

SF 5c 1 fragment of stem of goblet. Stem is hollow cigar type, broken before the base join and with an upper solid round knob. No decoration.

Soda glass, clear. Little weathering.

Illustrated fig. 42.

SF 5d 1 fragment of stem of goblet. Stem is hollow cigar type, broken before the base join and with a short extension and an upper solid annular knob. No decoration.

Soda glass, clear. Little weathering.

Illustrated fig. 42.

SF 5e 1 fragment of stem of goblet. Stem is hollow cigar type, broken before base join and also before the upper knob. No decoration.
Soda glass, clear. Little weathering.
Illustrated fig. 42.

These five stems are all from the same style of cigar stem vessel, the most popular type of goblet in the first half of the seventeenth century. They would appear to be an exclusively English product and were probably produced in London until the Civil War (Charleston 1984: 68). Whilst the base and stem are usually consistent in design, the form of the bowl can vary being trumpet, deep and convex or fluted in shape, with examples of all of these being found in the glass hoard from Gracechurch Street, London (Oswald 1949: 31). Unfortunately there is not enough remaining of these bowls to suggest what form they took. They are interesting in this context because they represent a deposition, in one action, of five goblets. They could have been quite complete on deposition and although only one base and no bowl fragments were recovered, this is probably more due to the nature of the excavation. Even if they were broken before being deposited this still represents the deposition of five similar goblets, presumably from a single domestic household.

The glass from both contexts at Culver street is important because it outlines the range of glass in use at Colchester. Area 'E' contained the remains of the imported Dutch vessel, the '*vetro a fili*' beaker in the same context as an English forest glass bottle and a goblet (Henkes 1994: 170-172). The second context in area 'A' produced a wide range of English forest glass, with no imported soda glass. The only soda glass from this context were the five cigar stemmed goblets which are of a seventeenth century date. Indeed the quantity of soda glass from this area of Colchester, with the exception of the cigar stems, is very low and suggests that the deposits from this area came from people who did not use such glass. Whether this is due to this area being poorer or indeed a very rich area where people used more expensive alternatives, is uncertain, but compared to other sites in this town quality soda glass is particularly poorly represented.

d) Cups Hotel

Limited excavations were carried out in 1974 on the site of the modern Cups Hotel in Colchester, figure 43. The area uncovered was very limited but it revealed the disturbed remains of the rear of a fifteenth century building which continued in use into at least the sixteenth or early seventeenth century (Crummy 1992: 336). The back yard and also a system of pits were discovered and it is from one of these pits, F167, and from unstratified contexts that the remains of seven vessels were found. Although the layers were disturbed, it is still possible to associate them with this building, as the area excavated was so small. Almost all the glass recovered was from drinking vessels, these being beakers.

SF 1009a 5 fragments of body and 1 of rim of beaker. Rim and body are vertical. Decorated with mould blown blobbed decoration.
Soda glass?, clear, slight green tint. Some weathering.
Rim diameter 6 cm. Illustrated fig. 44.

SF 1009b 2 fragments of base of beaker. Base is pushed in pedestal with a folded base ring. Not decorated.
Forest glass green. Quite weathered.
Base diameter 7 cm. Not illustrated.

SF 1013 1 small fragment of rim of beaker. Rim is slightly inturned. Not decorated.
Forest glass, green. weathered.
Rim diameter 8 cm. Not illustrated.

SF 1046b 1 fragment of rim of beaker. Rim is slight inturned Not decorated.
Forest glass, green. Quite weathered.
Rim diameter 8.5 cm. Not illustrated.

SF 1046a 5 fragments, 4 join, of rim of beaker. Rim slightly inturned. Decorated with mould blown wrythen ribbing running from top right to bottom left.
Forest glass, green. Quite weathered.
Rim diameter 8 cm. Illustrated fig. 44.

These five beakers are all very similar, with the exception of the first one, SF 1009a. They are of poorer quality forest glass and are either plain or wrythen decorated in the English style and date from the second half of the sixteenth century (Charleston 1984: 87-89). The first vessel however is different. It appears to be made of soda glass, although it could be good quality nearly clear forest glass. It also has quite a broad rim which is vertical rather than turned in like the typical English beaker. This appears to be part of an imported Dutch bossed beaker or *Knobbelbeker* which was produced

Figure 43- Cups Hotel Plan.

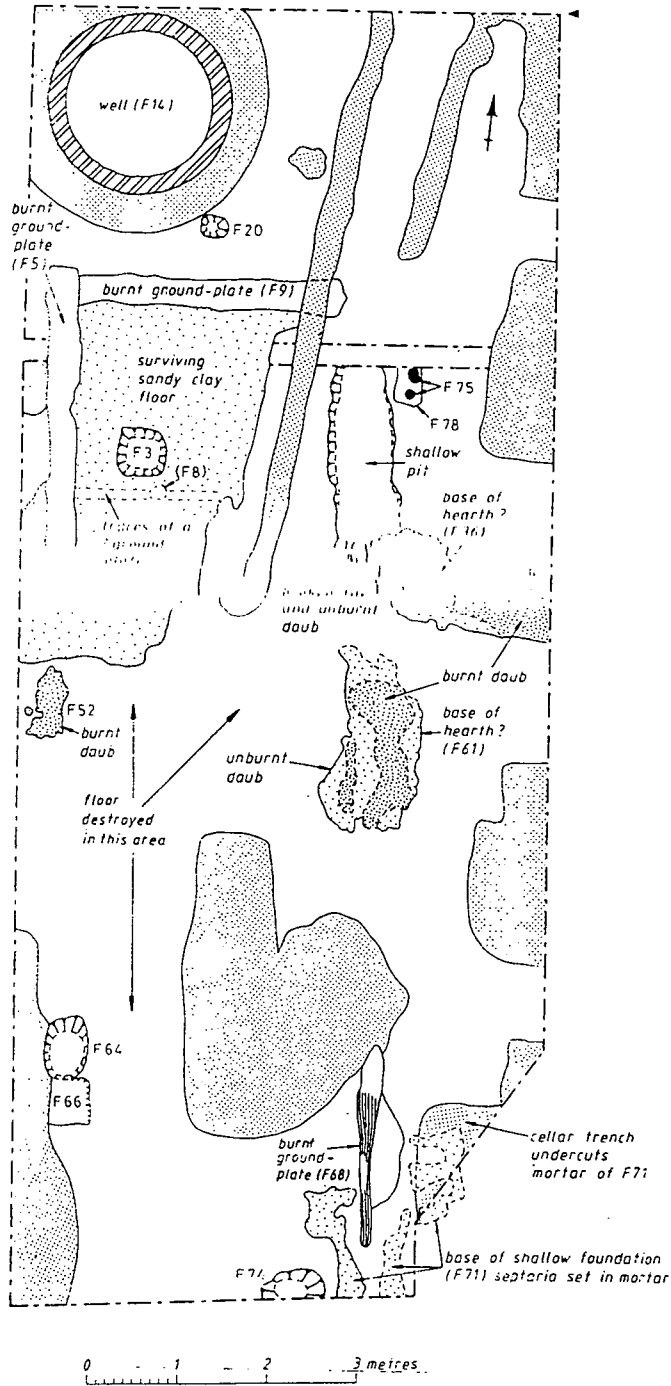
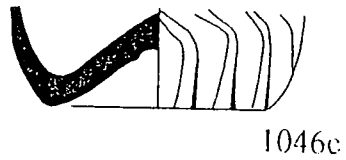
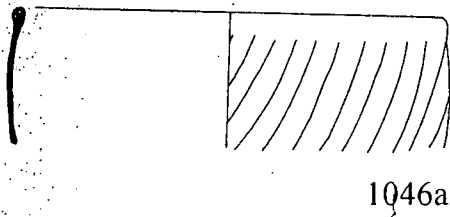
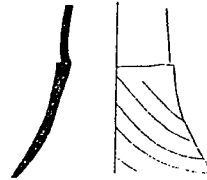
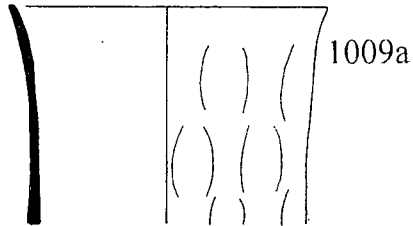
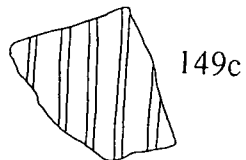
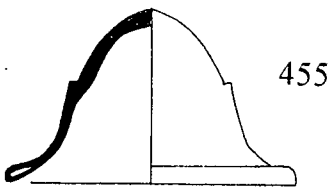

Figure 44- Cups Hotel and Long Wyre Glass.

Cups Hotel



Long Wyre Street



149b

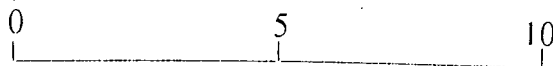

in varying forms from the middle of the sixteenth century to the end of the seventeenth (Henkes 1994: 137-138). Given the context of this example it probably dates from around 1550-1600. The only vessel which was not a beaker from this context was a small bottle.

SF 1046c 28 fragments, 1 complete base and 3, joining, of neck and shoulder of small oval bottle. Base is heavy, thick and pushed in, with a distinct pontil mark. Neck is tapering out with a distinct notch or change in thickness. Decorated in mould blown wrythen decoration running from top left to bottom right, which is particularly thick and heavy on the base.

Forest glass, green. Badly weathered.

Base diameter 4 x 3 cm. Illustrated fig. 44.

This small oval bottle is typical of the second half of the sixteenth century and almost certainly of English manufacture (Charleston 1972: 145). However it is important because it demonstrates how the wrythen decoration was created. The base shows that the ribbing is initially vertical and then it spirals up to the left. This is because the vessel was blown into an optic mould with vertical ribbing and then twisted when expanded by further blowing outside the mould. This example has very thick ribbing, because due to its small size it was not expanded very much on removal from the optic mould.

The glass from the Cups Hotel site suggests a deposit of almost exclusively beakers, a disposed of drinking set. This idea can be confirmed as Crummy states that this building was an inn from the fifteenth century when it was known as The Falcon (Crummy 1992: 336). This assemblage of glass would fit in well with an inn, presumably where beer was drunk out of these beakers. The deposit from the Cups Hotel can be seen as being directly produced by the buildings use.

e) 7-15 Long Wyre Street

7-15 Long Wyre Street was excavated in 1979 before to the redevelopment of the area into a large shopping centre, figure 45. The remains of various sixteenth and seventeenth century buildings were uncovered, but only the very rear of these survived (Crummy 1992: 356). The main features were the pits at the rear of these properties. The excavation concentrated on many of the Roman features of the site, so

Figure 45- Long Wyre Street Plan.

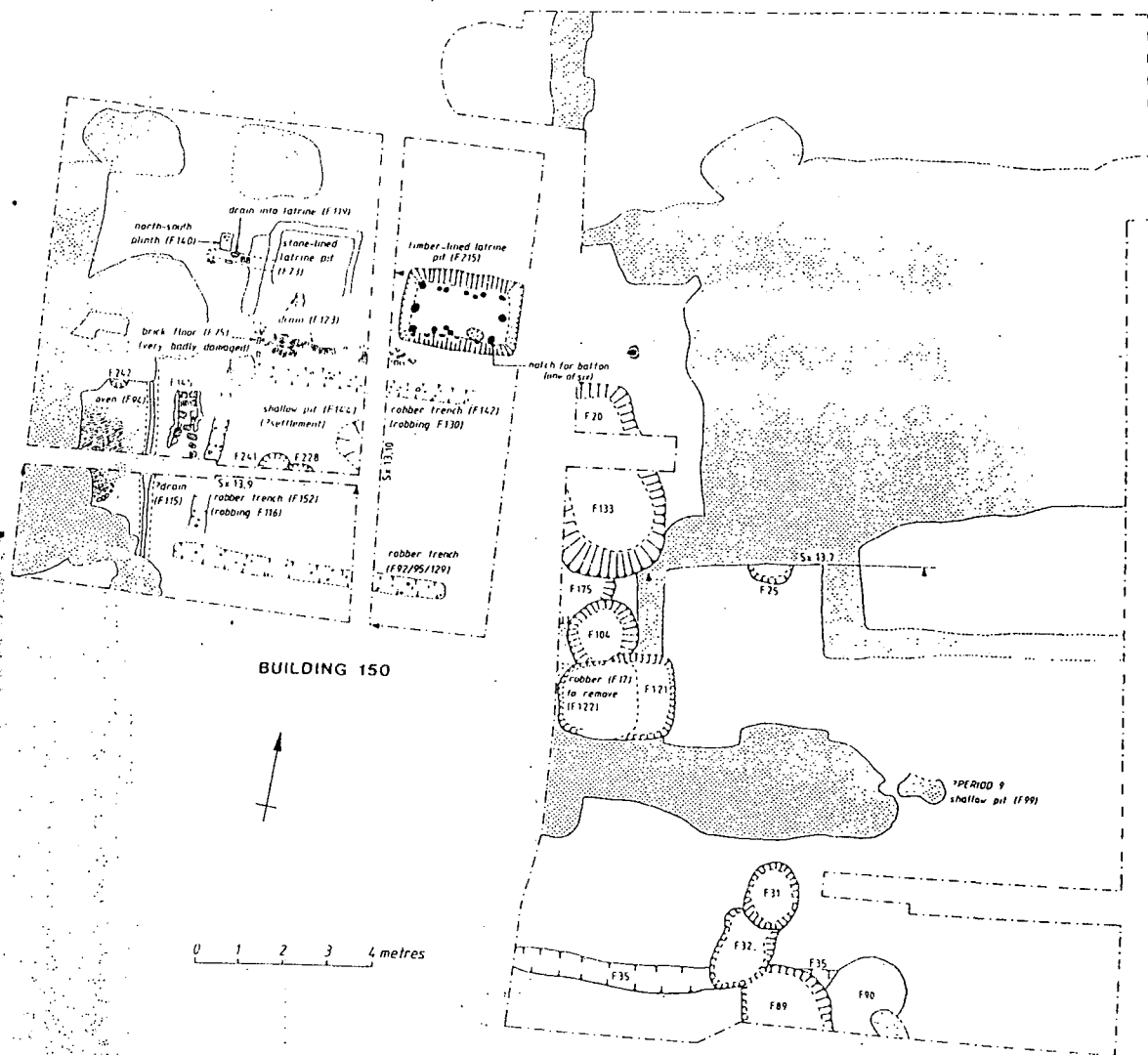

consequently not all sixteenth century contexts were recorded. Six vessels were found in this area, two being of soda glass and four of forest glass.

SF 149c 1 fragment of body of beaker. Body is straight sided. Decorated with mould blown vertical ribs decorated with wide bands of vertical opaque white.

Soda glass, clear. Some weathering.

Body diameter about 10 cm. Illustrated fig. 44.

SF 455 2 fragments, joining, of complete base of beaker. Base is pushed in pedestal with a folded over base ring. Not decorated.

Forest glass, green. Quite weathered.

Base diameter 5.5 cm. Illustrated fig. 44.

SF 149b 1 fragment of shoulder of lid. Shoulder is curving, leading to a flatten top, with a folded ring below. Decorated in opaque white *lattimo* decoration of alternating plain and twisted bands.

Soda glass, clear. Little weathering.

Lid diameter 13 cm. Illustrated fig. 44.

The first fragment of a beaker comes from an imported vessel, which was probably Dutch. This is a form seen in the Low Countries, coming from a broad beaker with a pushed in base (Henkes 1994: 144-146). By way of contrast the second vessel is a pedestal base from an English style beaker from the second half of the sixteenth century. This is a far more common vessel and represented on most sites of this period (Charleston 1984: 87-89). The third fragment is more unusual, being from a twisted cane *lattimo* lid from either a goblet or a beaker. This type of vessel is known to have been produced in Venice between 1550 and 1600 and a complete example is known from Utrecht (Tait 1979: 73; Henkes 1994: 177, no. 41.13). Three other vessels came from this area, all of them being forest glass flasks.

SF 149a 14 fragments of body and 1 complete base of flask. Rim is everted, the neck straight and tapering to a convex shoulder. The base is pushed in with a medium kick. Decorated with mould blown wrythen ribbing.

Forest glass, green. Some weathering.

Rim diameter 4.5 cm. Base diameter 6.7 cm. Not illustrated.

SF 135 1 complete base of flask. Base is simple pushed in, with high pointed kick and clear cracked off pontil mark. Not decorated.

Forest glass, green. Quite weathered.

Base diameter 7 cm. Not illustrated.

SF 165 2 fragments, joining, of small base of bottle. Base is pushed in with a shallow kick. Not decorated.

Forest glass, green. quite weathered.

Base diameter 3.5 cm. Not illustrated.

These three forest vessels are the usual flasks and bottles associated with most sites from the sixteenth century. The first two vessels are large flasks for holding any number of liquids, whilst the small bottle could contain ointments. Combined with the drinking vessels this small group represents the varied and diverse glass that was used by the households along this part of Long Wyre Street.

A final note must be made of a nearly complete example of a *Wafelbeker* from the Colchester excavation. It was found from the Lion Walk site, although it was not from either of the areas already examined. It is particularly important as it is the most complete example of this form from any of the study sites examined for this thesis.

Many fragments of rim, body and base of beaker. The rim is everted, body vertical and the base pushed in with and applied rouletted solid base ring and a distinct pontil mark. Body is decorated with seven cut spiral trails and three applied rosette prunts, one with an inserted blue bead.

Soda glass, clear. Little weathering.

Rim diameter 10 cm, base diameter 7.2 cm, height 15 cm. Capacity around 700 cl. Illustrated fig. 46.

This beaker was almost certainly deposited whilst whole, the proportion of it surviving is very high and most of the breaks are recent and not weathered. It serves to demonstrate the original appearance of one of these *Wafelbekers*.

Figure 46- The Colchester Wafelbeker

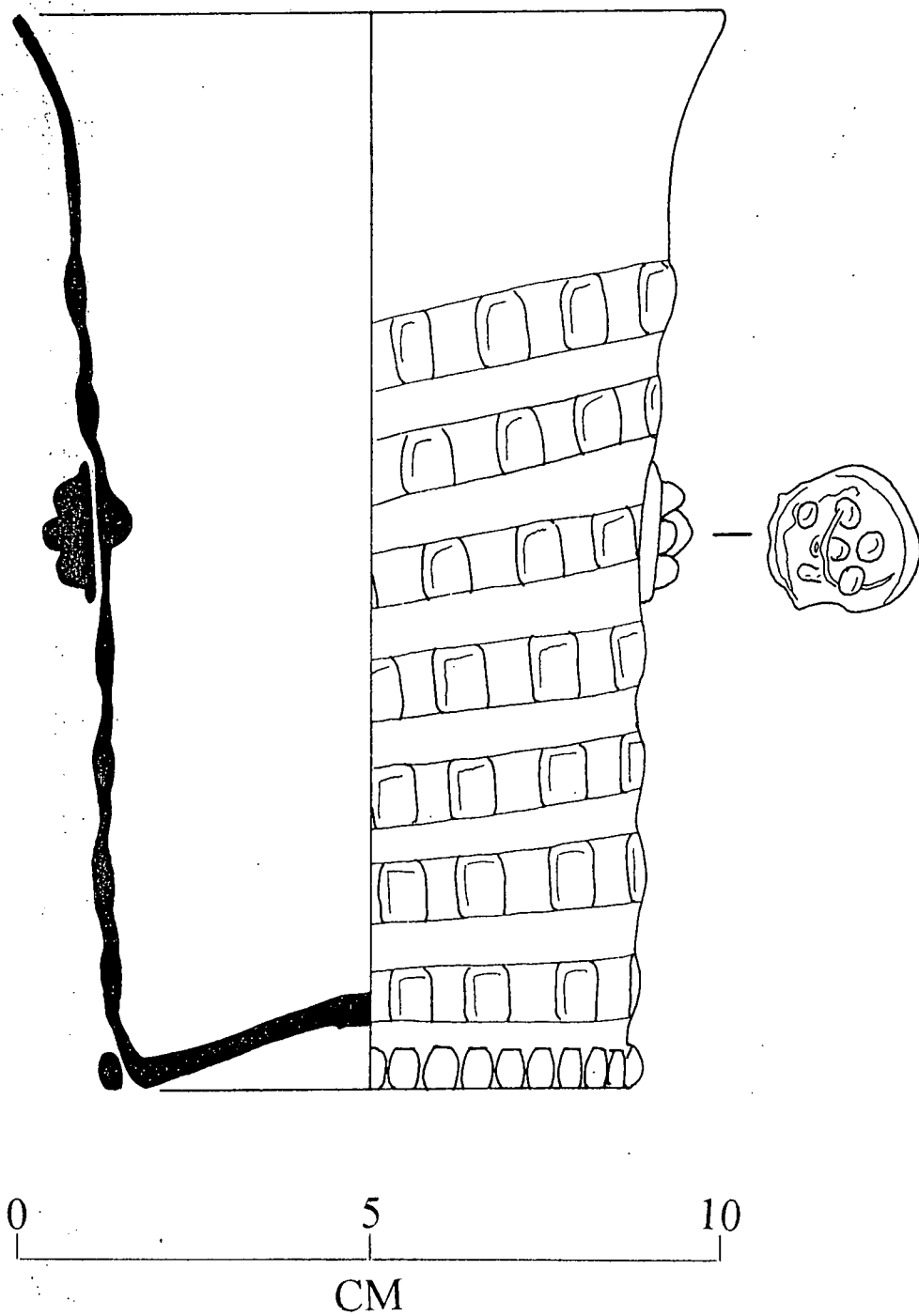

Chapter 7- A Typology of Vessel Types

It is one of main aims of this thesis to discuss the vessel types in use in sixteenth century England. This discussion is based upon the glass observed from the five study sites, so is not completely comprehensive of all the forms of vessel in use in this time. However it is only by using this approach that an accurate typology and chronology can be derived from the archaeology. Clearly it will require subsequent work to increase the diversity of forms covered and to refine their dating. The glass has been classed under five broad categories: beakers, goblets, flasks/bottles, urinals and funnels

Beakers

A beaker is a cylindrical drinking vessel with a base but with no handle. It was originally thought that in the medieval period beakers were the only form of drinking vessel and that tall stemmed goblets were a sixteenth century innovation. However this has since been shown not to be the case, although beakers were common forms of drinking vessel in England between 1200 and 1400 (Charleston 1984: 19-20). They were often squat soda glass vessels with a pushed in base and outward flaring rim, sometimes being decorated with blue trailing. By the beginning of the sixteenth century this form of vessel was no longer produced and beakers themselves were uncommon. The only form found in the first half of this century in England was the imported soda '*moioli*', figure 47c, which in both archaeological and pictorial contexts was accompanied by the tall '*inghistere*' style flask, figure 52b. This form of beaker has a vertical rim and side with a simple pushed in base with a high pointed kick. They do not appear to have been decorated with any additional trailing and are distinctive when fragmentary by their plainness and the good quality of the metal. It does not seem likely that this form of vessel survived later than the first quarter of the sixteenth century, being more common in the fifteenth century. It appears that there were no potash beakers from this period.

Figure 47- Beakers

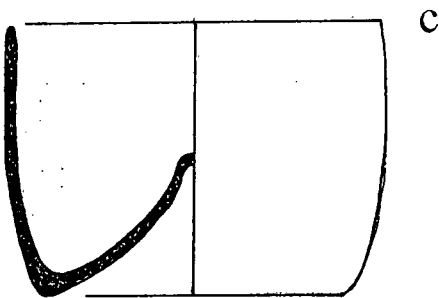
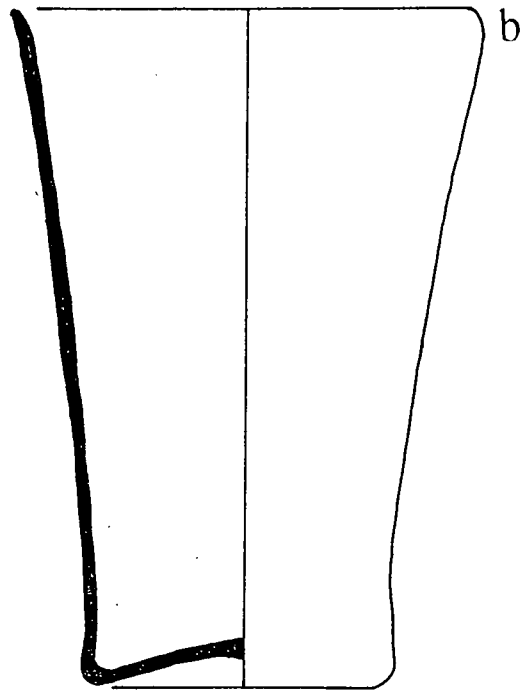
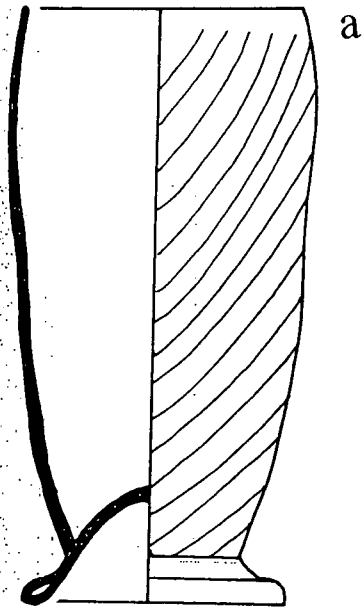

It is curious that there is no solid evidence for the common use of beakers between around 1525 and 1550. In this they are not alone as the other main glass drinking vessel, the goblet, is also largely absent at this period. Soda drinking glasses seem to diminish after the weakening of trade links between Venice and England, with the home produced potash 'imitations' doing likewise. It is only with the revival or more correctly the implantation of a better quality industry under Elizabeth that drinking vessels of either alkali were largely revived (Godfrey 1975: 14-15). Those soda vessels that are found are probably the result of private importation rather than the more organised trade of previous years. Quite when beakers of either soda or potash glass were first extensively used and indeed became the most common vessel type by the end of the century, is unclear. However with home produced and imported potash beakers there was a revival in their use by the time that Verzelini had established his glass house at Crutched Friars in London in the 1570s. Potash beakers were produced in great numbers in the following years, as the quantity of them from the late sixteenth century glass houses at Hutton and Rosedale demonstrate (Charleston 1972: 136). They followed largely the same design well into the first quarter of the seventeenth century when they seem to have ceased being made. There are seventeenth century beakers of this form from the glass hoard at Gracechurch Street, London which probably dates to around 1640 (Oswald 1949: 35)

There are two principle forms of English produced forest beakers from the second half of the sixteenth century. The most common is the pedestal base variety, this vessel being made from a single blown bubble of glass. The base was pushed in to such an extent that it joined the outer surface of the glass, forming a trapped bubble of air as a base ring and when manipulated by the glass maker becomes a narrow pedestal on which the vessel could stand. The sides of the vessel taper outwards from the narrow point where they join the base, and curve in a slightly convex manner, figure 47a. However the rims on this form are almost always slightly inturred, so that the widest part of this vessel is often several centimetres below the rim (Hume 1962: 162 fig. 1). The second type of English forest beaker appears to be less common, and

it is of a more simple design. The base was pushed in with a low kick to produce a stable surface on which the vessel could stand. This was often decorated with an applied solid base ring, although this would appear to be purely symbolic as it does not improve the stability of the vessel, figure 47b. Consequently the lower sides of the vessel were wider than the pedestal variety and do not tend to taper outwards to the rim. These beaker sides were either vertical, joining a upright rim or are slightly convex in the middle, producing a very gentle 'hour glass' shape and creating a slightly everted rim (Hassall 1984: 241). Both these varieties appear to have been made together and used in the same period with the evidence from Hutton and Rosedale suggesting that they were produced at the same locations (Charleston 1972: 146-150).

It is the decoration of these forest glass beakers that shows the most variety and nearly all are blown into an optic mould, with only a few being undecorated. All the optic blown decoration is created by blowing a parison into a one piece patterned mould. An example of one of these can be seen in the engraving of a sixteenth century glass house in Agricola's 'De Re Metallica', figure 48c (Hoover 1950). When this has been done it is removed and manipulated to complete or enhance the pattern and only then is it inflated further so that the design is stretched and smoothed out. Consequently there are no seams and the pattern can often be seen beneath the base, unless it has been stretched to such an extent it can not be seen or is obscured by the pontil mark. Unlike other optic blown vessels such as flasks and bottles a greater variety of designs other than the standard wrythen type were used. Wrythen is the most common decoration and is usually crisp and narrow, as opposed to the wrythen found on flasks. A similar decoration is a vertical running fluting, which often twists just below the rim. Further more complicated designs were also produced, both diamond, lozenge and occasionally hexagon patterns being popular. These mould blown patterns are sometimes combined into a compound decoration with a vertical ribbed design on the top half of the vessel and a diamond pattern below, this requiring a very complicated single optic mould.

Figure 48- Optic Moulds

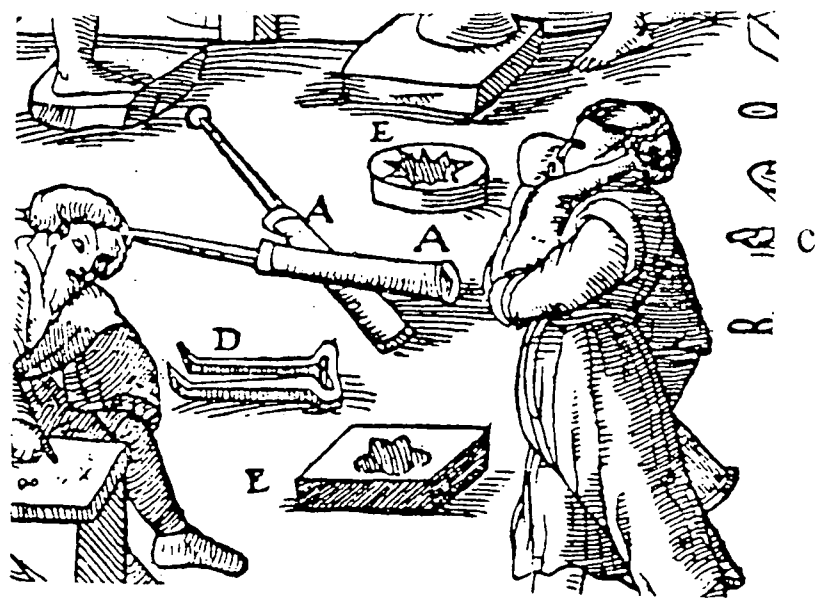
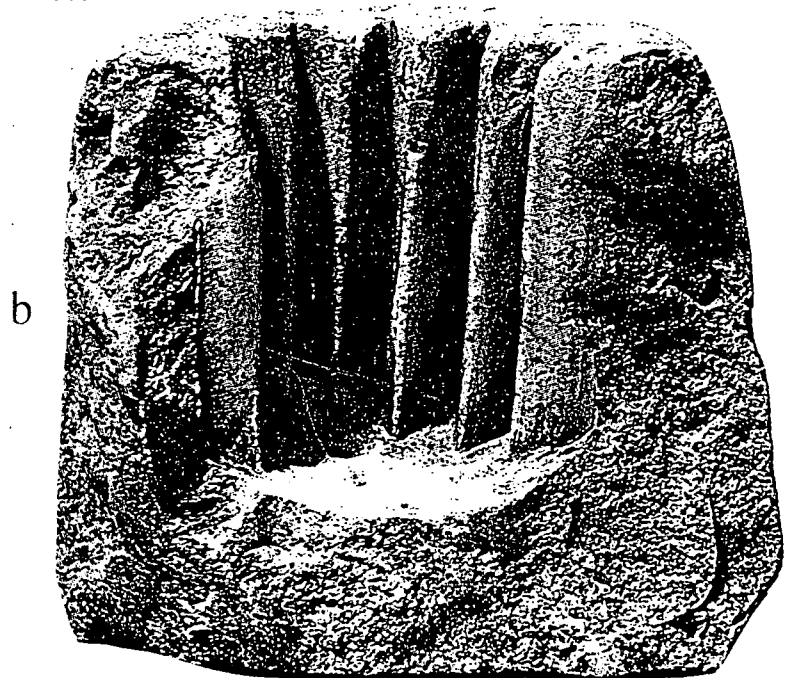
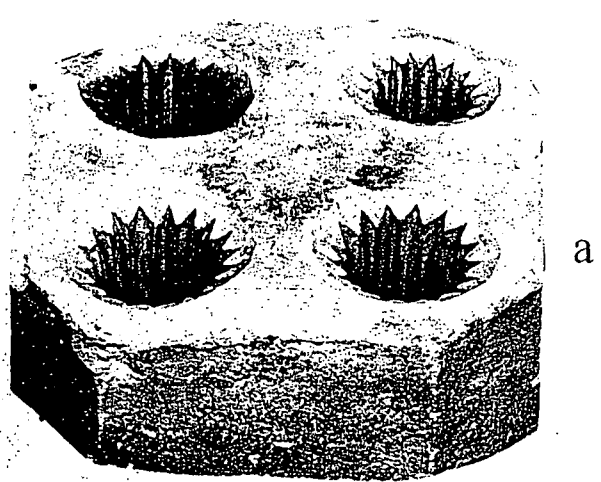

The use of the optic mould at first sight seems a complex way of producing decorated vessels, with the mould itself require careful engraving. These were probably made from a soft fine carvable stone, such as the late medieval examples found at Nassachtal, Germany, figure 48b (Baumgartner 1988: 35-36) and Solling, in the Netherlands, figure 48a (Henkes 1994: 129). There are as of yet no remains from English glass production sites of any mould fragments. The use of the optic mould however was an easier and far quicker way of producing as many decorated vessels as possible. It removed the need for a two piece mould that fitted neatly together and once the glass was blown into it, it did not need to cool slowly to keep its shape.

Soda beakers, in the sixteenth century, do not appear to have been produced at all in England, there are no examples that can positively assigned to this country. Indeed Robert Mansel, who took over the glass monopoly in 1615, claimed to have introduced the first 'beer glasses in crystal' (Godfrey 1975: 218). However, whilst forest beakers are clearly the most common variety in late sixteenth century England, there are the remains of soda glass imports. Few published works have highlighted the significance of these vessels, for example Charleston's "English glass and the glass used in England". He only recognises the presence of the *moioli*, in the first quarter of the sixteenth century, and this is probably the only beaker form which is imported from Venice into England (Charleston 1984: 43). However it is clear that a certain amount of glass from the Netherlands was being imported in the second half of the sixteenth century and this has largely been ignored by English glass scholars. A notable exception is Tait's identification of a few of the Low Country forms from the Southern Netherlands, although he does not discuss their importance in English contexts (Tait 1967: 94-112).

Four basic varieties of Low Country beaker have been found on sites in England, although these are not the full range produced. All the varieties of these beakers share similar characteristics, with low pushed in bases and applied solid base rings, straight vertical sides and everted rims. This plain form is the first category of these vessels. Not these all beakers have these features, some do indeed have a

Figure 49- Low Country Beakers

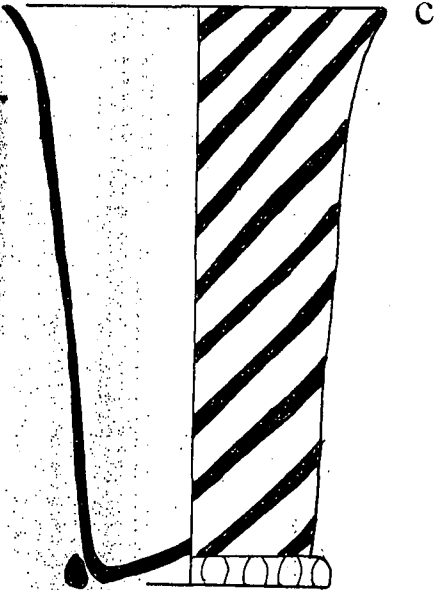
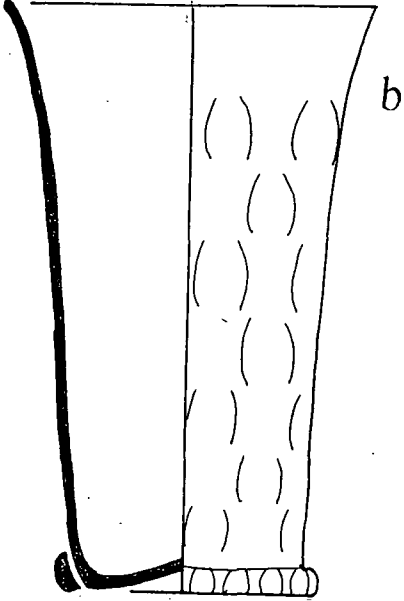
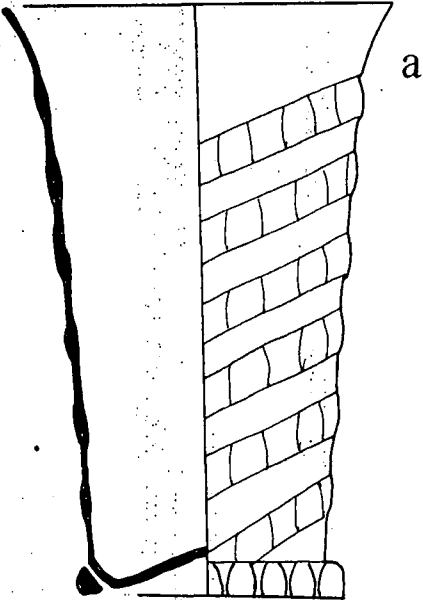

vertical rim, but this is probably a later seventeenth century feature (Henkes 1994: 138). The plain pushed in base beaker also comes in a squatter variety, often without a base ring. This type when fragmentary is hard to tell apart from the Venetian *moioli* and does not appear to be very common. The forms that are more frequently found in England are the decorated beakers.

The *Wafelbeker* appears in quite large quantities on some sites in England and has a very distinct decoration, figure 49a (Tait 1967). It is made by taking a parison of glass, winding a spiral trail around it and blowing it into a vertical fluted optic mould. This has the effect of cutting the spiral trails which are then drawn apart when the vessel is fully inflated (Henkes 1994: 130). Often this type of vessel is then further embellished by the application of rosette prunts, sometimes with a blue bead in the centre, (a complete profile of a *Wafelbeker* found at Colchester is illustrated in chapter 6, figure 49).

The plain beaker form was also decorated with mould blown blobs or bosses. These *Knobbelbeker* are an optic blown form which does not seem to be used on English forest beakers, figure 49b. The *Knobbelbeker* is not as common on English sites, although remains have been found at Colchester and London (Oswald 1949). Its form is sometimes similar to the everted rim beaker, although some very squat versions have been found in the Netherlands, but not yet in England (Henkes 1994: 140-141).

The final and least common imported beaker design from the Netherlands is the filigree beaker. This design was originally used in Murano in the second quarter of the sixteenth century, although all examples found in England appear to be Dutch varieties dating from the 1560s onwards (op. cit.: 170-176). They appear to have been made by the laying out alternating opaque white or blue glass canes on a marver block. A parison of glass was then taken and rolled over the canes, gathering them up on to its outer surface. The glass was then further inflated to produce the vessel shape, figure 49c: This is always the same vertical sided everted rim form that both the plain and the *Wafelbekers* are formed into, and some times have applied rosette prunts.

The function of the common potash beaker has always been assumed to be for the holding and drinking of beer and this is most likely to be true (Charleston 1984: 87). The consumption of other liquids in this quantity was very limited, water was seen as an unhealthy drink (van Dongen 1994: 10). The increase of beer consumption was also dramatic at this period, the practice of adding hops to the ale as a preservative increasing the demand for this form of nutritional supplement. The capacity of these beakers would indicate that they were not intended for wine or spirits and beer was the most popular form of alcoholic drink. By the period of the Mansel glass works, in the early seventeenth century, these beakers were being described as 'beer glasses' (Godfrey 1975: 45-46) and it would seem likely that no dramatic change in function of these vessels had taken place from the sixteenth to the seventeenth century. The imported soda beakers from the Low Countries were apparently used for the same function, despite their far larger capacity. They are sometimes depicted in seventeenth century still life paintings being filled with beer (van Dongen 1994: 10). This would also explain why the forest vessels are so common, with most households brewing their own beer. This was probably still the case in rural areas in the sixteenth century and the growth of taverns and inns in the latter half of this century in urban areas would have encouraged the use of glass.

Goblets

Goblets are vessels that in their most basic form have bowls supported by a stem, so that much of the vessel height is not taken up by that part which holds the liquid. Goblets were produced, certainly in Venice, from the twelfth century onwards. Until the sixteenth century goblets were not used in any great quantity and the goblet became a significant item of domestic tableware only with the establishment of the immigrant glass houses in the second half of the sixteenth century (Thorpe 1961: 86-93). Forms of goblet were produced in both potash and soda glass, although these different media are stylistically different. It is generally assumed that goblets were used primarily for the consumption of wine and other drinks taken in smaller

quantities. Certainly most of the forest goblets are of smaller capacities than their beaker contemporaries but in the case of the later soda glass goblets this is not necessarily the case (Charleston 1984: plates 12-14).

In the first half of the sixteenth century there appears to be no evidence for either the production or the use of forest goblets in England. From the five study sites examined for this research not one fragment of such a vessel could be securely dated to this period. Even during the middle of the sixteenth century there seems to be an absence of forest goblets. Whether this reflects the state of the English glass industry at this juncture is uncertain. However by the last quarter of this century forest goblets reappear on glass making sites such as Hutton and Rosedale in Yorkshire, and also in archaeological contexts (Charleston 1972: 148). There appears to be only one type of goblet produced, which continues in use into the seventeenth century. Its form is made out of a single piece of manipulated glass, consisting a vertically sided bowl with a vertical upright rim, which rests on a folded pedestal stem. This stem is either relatively short or there is a more elongated version with a crude applied knop near the top of the stem (Ibid.). The bowls of these goblets are often plain, but can be decorated with a variety of thin trails running horizontally, figure 50b.

Again there are several problems associated with the identification of these vessels when they occur in fragmentary form. The rim diameters and shapes are similar to beakers and can easily be confused. However these goblets rarely have mould blown decoration so it is mainly only the plain beaker and goblet rims that may be mis-interpreted. The folded pedestal stem is much narrower and taller than the equivalent base from a beaker, so they can be easily identified. A further problem is that it is uncertain how common these vessels were in the late sixteenth century. Evidence for them comes from the excavations of the glass houses of Hutton, Rosedale and Woodchester (Charleston 1972: 148; Hurst-Vose 1995: 27) as well as from occasional large deposits, such as at Gracechurch Street in London, which

Figure 50- Goblets

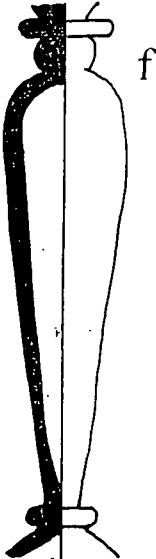
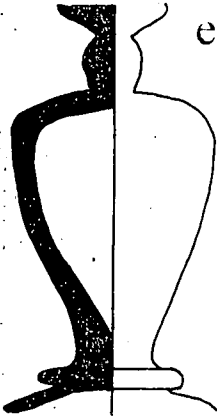
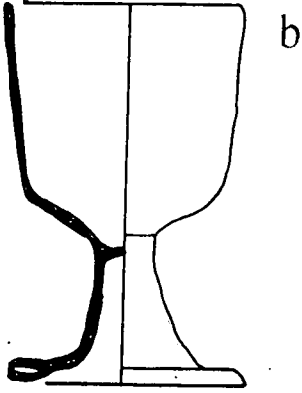
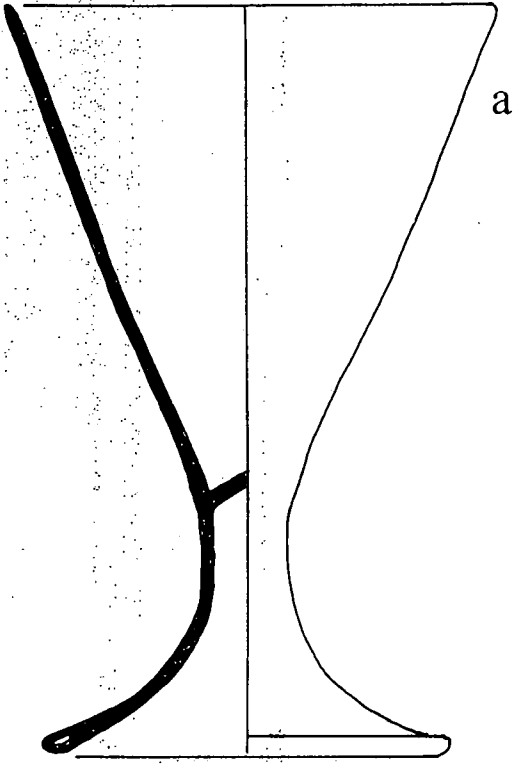

suggests that they were a common item like the beaker (Oswald 1949). However on the five areas investigated in this study their numbers are comparatively low, with fewer of them occurring than soda glass goblets. This would suggest a number of possibilities, but whether this is a matter of identification difficulties or a true distribution variation is unclear. It would seem likely that these vessels should be a relatively common low status vessel and there is no reason for them not being as popular and common as beakers. However this might suggest that the class or status of people who drank wine could afford or had better access to soda glass.

There can be little doubt that all forest glass goblets were manufactured in England, as those from excavated contexts are stylistically identical to those from sixteenth century furnace sites (Hurst-Vose 1995: 27; Charleston 1972: 148). It is a little surprising that there is so little variety in their design, compared with soda glass goblets. These goblets tend not to be decorated with optic blown decoration as are beakers, so they have far less potential to display variety. Why this is the case is not obvious, as goblets could easily be optic blown, but it might have had something to do with their use and the nature of the contents they were intended to hold.

When it comes to classifying soda glass goblets there are more problems than with any other vessel type in any metal. This is due to the great variability of their form reflecting the skill of the sixteenth century glass maker. When certain goblets, such as those made by Verzelini, are examined they appear to have been as much an item of display as a functional vessel. The quality of craftsmanship and effort put into the decoration of the surviving vessels attributed to Jacob Verzelini brings to question whether these goblets were ever intended for use (Charleston 1984: plates 12-14). This is confirmed by the numbers of them that remain intact and not from archaeological contexts as opposed to other vessel types. Of the thirteen surviving vessels directly attributed to Verzelini by Charleston in 1984, all are goblets and all but one diamond engraved (Charleston 1984: 55-59). Even vessels of a poorer quality than those produced by Verzelini are extremely variable in not only size but form. However it is possible to categorise these soda glass goblets by the form of the stem.

Like their forest counterparts soda glass goblets are uncommon in the first half of the sixteenth century. They follow the trend of beakers to suggest that although utilitarian glass in the form of forest flasks, urinals and lamps was extensively used in the first half of the sixteenth century, drinking vessels were not. The evidence suggests that none were being produced in England in this period and the earliest imports came from Venice. A common form was a vessel made from one piece of glass with a tall folded pedestal base and bowl of similar shape, sometimes divided by a large central knop, figure 50a. The appearance of these vessels was largely symmetrical and it is well known from Venice itself (Tait 1991: 164). These were either plain or decorated with mould blown ribbing. A number of them were decorated with miliflore patterns, made up of fused canes of twisted translucent and opaque glass, blue and white being the most common colours used. This form of vessel was certainly present in England by the early sixteenth century, if not before, although whether it continued largely unaltered into the seventeenth century in England as it did in Venice is doubtful. It would appear that the earliest examples found in England are plain, although in the latter half of the century the twisted strip *lattimo* variety predominate (Tait 1979: 72). It would seem that with the revival of the English industry of quality ware in the second half of the sixteenth century these vessels fell out of favour more quickly than they did in other parts of Europe. They certainly are the least common form of soda goblet to be found in England and were probably eclipsed prematurely here by the expansion of the Northern European industry.

Most soda goblets from this period are not of this folded pedestal form but have a narrow stem with a central knop. The bowls of these vessels are usually 'U' shaped and of a greater height than they are wide. These bowls are separately blown and attached to a stem that has been marvered into one or more solid or hollow knops. The bases are wide and shallow, with a folded under base ring and a pontil mark on the base underneath the stem. Stems from these vessels fall into four categories, the first being the solid knop, figure 50. This is probably the least common stem form from the sixteenth century, the majority of goblets having a separate hollow blown

stem. These stems are short and have one or more solid knops, an example being from Lion Walk in Colchester, chapter 6, figure 40. The hollow globular knop is the most usual type found on the Verzelini goblets, being mould blown with ribs and applied to the base and the bowl of the goblet as a separate piece (Charleston 1984: 57-59). Likewise the hollow free blown inverted baluster stem is quite common. This design was popular into the seventeenth century along with the globular variety and appears on the later elaborate serpent and flower stemmed goblets of the second half of the seventeenth century (Tait 1991: 175). The final variety of stem was a development of the inverted baluster, which was elongated to form the 'cigar' stem. This is primarily a form from the first quarter of the seventeenth century, although Charleston suggests that they may have originated in the last years of the sixteenth (Charleston 1984: 68-69).

There are a distinct group of goblets on English sites that have mould blown stems. These vessels were made in three parts with the central stem being blown into a two piece mould. The bowls and bases of these vessels are of the same form as those of with a solid or free blown hollow knop stem and first occur in the second half of the sixteenth century. So far only two different designs have been identified, although within these there are variations from each individual mould, figure 51. The most common is the lion mask stem. This is composed of two frontal view lion faces on opposite sides of the stem, with stylised decoration between them down the seam line, usually a cluster of several pellets (Oswald 1949: 31 No. iv). Above and below the lion masks are rounded tear drops that continue until the stem joins either the bowl or base of the vessel. The lion mask stem is a well known form from most glass houses in Europe in the second half of the sixteenth century and these occur on Venetian, Dutch and English vessels. There is further evidence that they were being produced in Laibach, Croatia (Kos 1994: 92-97) and probably in France (Goetz 1990: figs. 8-9). It is curious that these lion mask stems are so universal over Europe, as no other vessel feature is so ubiquitous. If it were a product of a single glass house then it could be described in terms of trade, but it would appear that the lion mask stem was

Figure 51 - Mould Blown Stems.

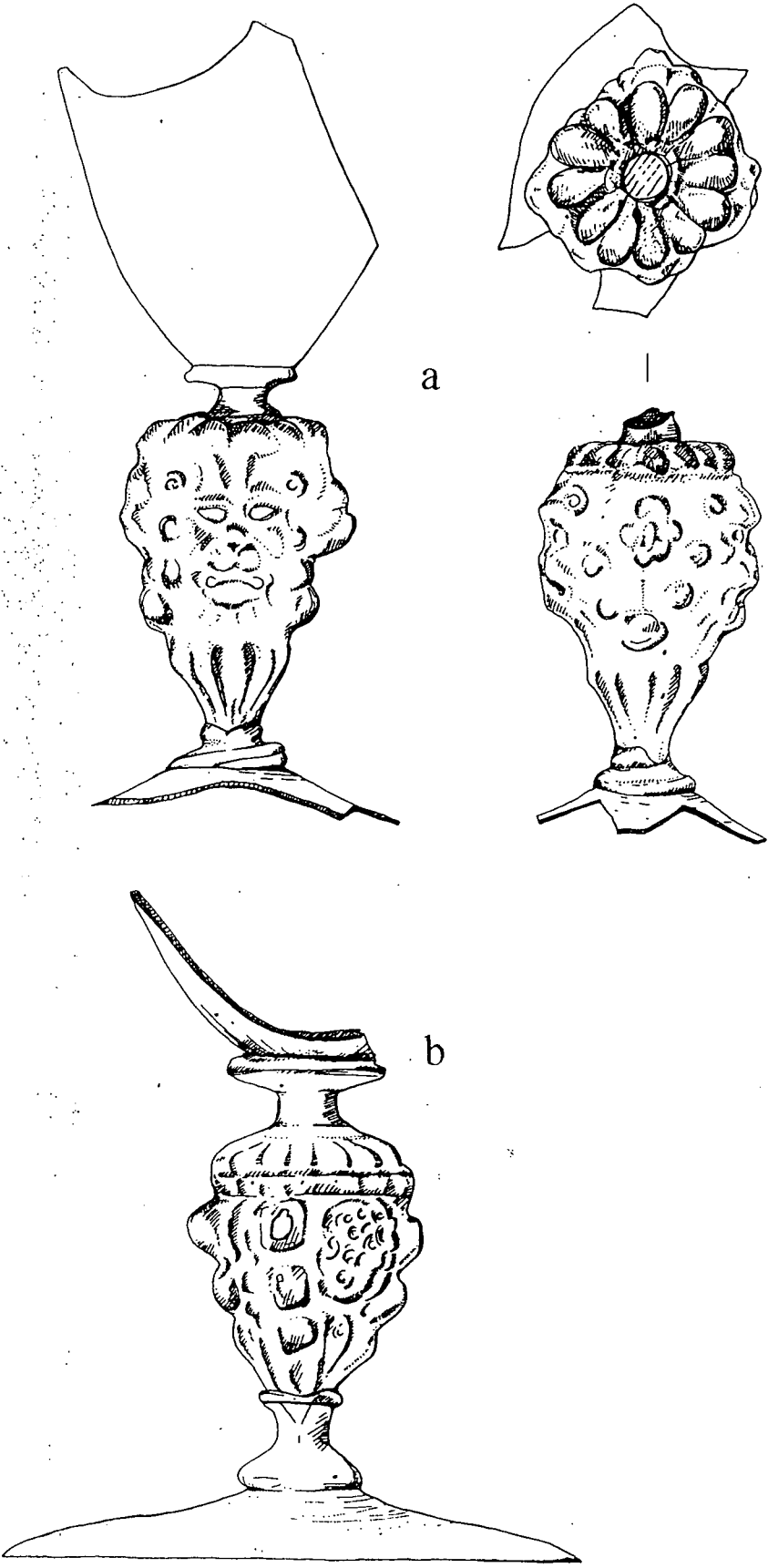

of such fashionable appeal that it was the only such distinctive feature to ever be copied all over Europe. It has been assumed that the form was first made in Venice where the greatest numbers of these vessels were made and the technical expertise was available to develop the fixed mould blowing. Nevertheless there is no evidence for this. However the rapid spread of the lion mask stem suggests that it had a symbolic meaning, whether it was of status or specific function is uncertain.

Lion mask stems are found on English sites until the Civil War, with the latest positively dated example coming from the destruction levels of Basing House (Moorhouse 1971: 65). They varied little in form and therefore can not be easily identified in themselves, although if enough research is undertaken it might be possible to identify individual moulds and therefore not only to date these vessels but also source them. It will certainly require further investigation until these stems are fully understood.

The other variety of mould blown stem that occurs in the sixteenth century is the ladder stem. This stem consists of vertical panels which enclose raised mould blown bosses, that resemble a ladder. This stem seems to have first been produced in the last decade of the sixteenth century, one being on the 'Winifred Geare' glass of Verzelini, engraved with the date of 1590 (Thorpe 1961: plate 16). They run parallel in usage with the lion mask stems, appearing on the same types of goblet from the same period. They differ in their distribution from the lion stems, whilst they appear on English sites they are very rare on the continent (Charleston 1984: 69). A uniquely English manufacture seems certain, although why this type of decoration was made and why it was not popular on the continent is unclear. Indeed it would seem strange that with the ability that European glass houses showed for producing mould blown stems that other designs were not also made. The most likely explanation for this is that the particular design chosen had some significance that would have been lost if any other pattern was produced.

Flasks and Bottles

When addressing the definition of a flask as opposed to a bottle a number of problems arise. The two classifications merge so that it is often hard to tell them apart, so perhaps flasks and bottles should be perceived as one and the same form. However if it is possible to determine them apart it would be useful to do so and flasks here are defined in separate terms by the function that they served. For the purpose of this thesis, flasks are vessels that were intended for the temporary holding of a variety of liquids and their serving into vessels from which they were to be consumed. Bottles are therefore defined as objects whose purpose was the longer term storage of a liquid. This is not say that bottles could not have functioned as flasks, in directly filling a drinking vessel or that flasks could not have stored liquids for some time. The crucial difference is not just functional, which is hard to assess, but also stylistic. The flask is typified by a long narrow neck that is at least a third of the total vessel height and has an everted rim. Both these features facilitate the pouring of a liquid. A bottle by contrast has a shorter neck and a rim which, although on the outside may be everted, on the inside remains nearly vertical. A bottle rim of this design gives the strength required for the use of a semi-permanent stopper. Flasks however would not have been strong enough for this kind of blockage and are sometimes depicted in household scenes merely with an upturned beaker covering the neck (Charleston 1984: plate 10b). Whether this difference in terms was perceived in such a way in the sixteenth century is doubtful indeed.

Forest flasks, along with beakers, are the most common sixteenth century glass vessel form found in England and are represented on virtually every type of site. Their form is largely conservative, with little change occurring between the twelfth and seventeenth centuries, although the quality of the glass does improve during the last century of their life span (Charleston 1984: 33-34). It is argued by Charleston that these vessels were the precursors of the late seventeenth and early eighteenth century wine bottle, although this conclusion is drawn by the appearance of the first wine bottles at the time when flasks ceased being used, rather than through any solid

Figure 52- Flasks.

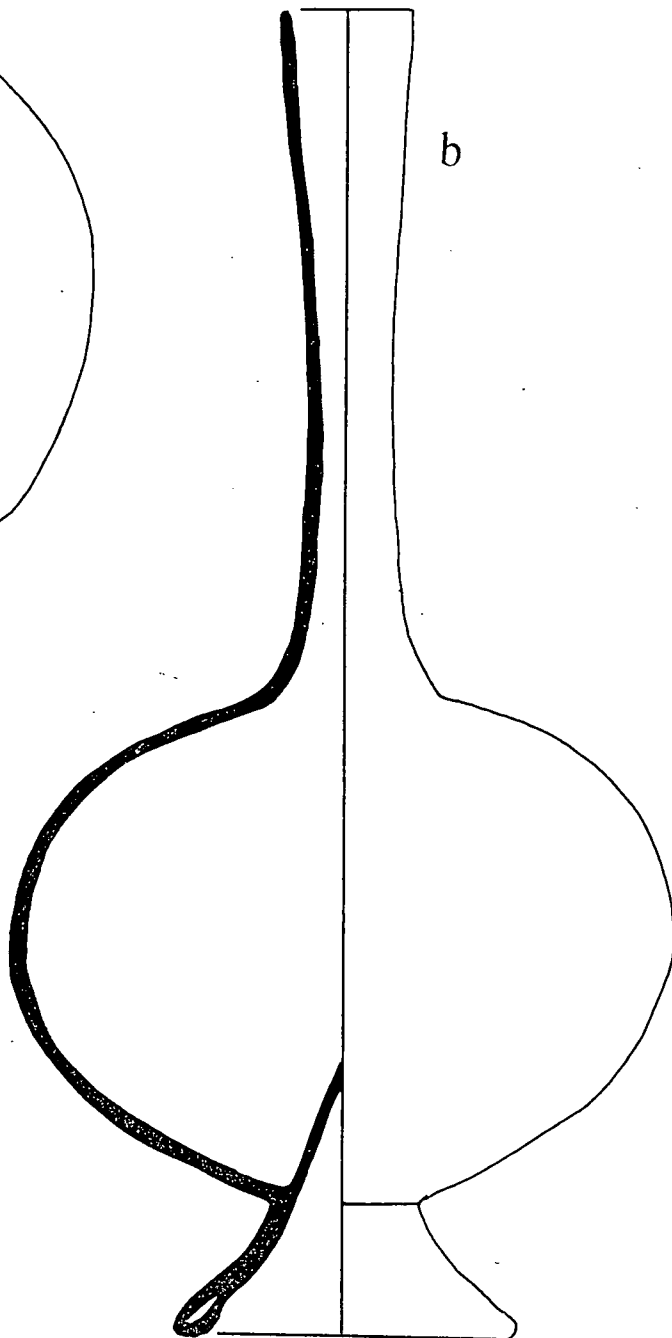
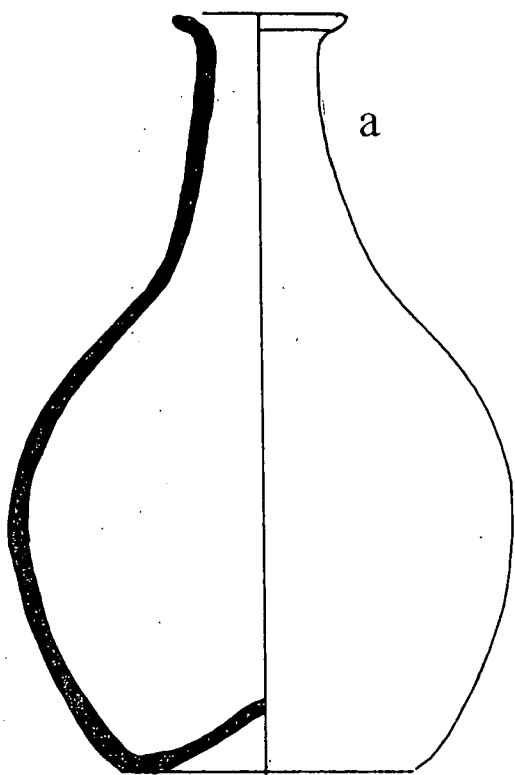

typological argument. These flasks were made in a vast range of sizes and with a number of different stylistic features. All their rims are everted with upright narrow necks. The diameter of the rim varies according to the size of the vessel but is never more than a third of the width of the base. The neck usually is about the third of the total height of the vessel and joins the body with a rounded shoulder, figure 52a. Most forest flasks have a spherical body but some (generally the smaller ones) appear to have been deliberately made ovoid in cross section, although there is no apparent functional value to this. The bases are generally of the simplest form, being made by pushing in the bottom of the blown glass bubble with the pontil iron so that the vessel rests on a newly flattened surface. On a few of the larger flask bases the pontil is pushed in sufficiently and the glass manipulated so that the 'kick' touches the inside of the vessel to create a folded base ring, adding greater stability to a large vessel. It is this feature that would appear to be unique to the latter half of the sixteenth century, but only because flasks of this size were not produced earlier, rather than for any technological reason.

The decoration on flasks only consists of the optic blown wrythen variety. Flasks are often left undecorated but are commonly found with wrythen which is carried out at the half way stage of the vessel's production, before the base is created with the pontil iron. The wrythen decoration reaches from below the rim to underneath the base and is lightest on the body, this being the point which was stretched the most with further inflation. On some flasks the wrythen decoration is even faint on the neck and can not be seen on the body. Although it is not always the case, the trend is that the larger the flask the fainter the wrythen ribbing. This suggests that the same size optic mould was used for all flasks, and that the final size of the flask was dependant on the amount of subsequent re-inflation.

It is important to concentrate briefly on this mode of decoration as unlike other optic blown vessels, such as beakers, it is the only form that occurs on flasks. It is possible that it is a functional item that helps stop the hand slipping when a potentially heavy vessel is lifted. However it is entirely possible that it is a

Figure 53- The Mary Rose Flask.

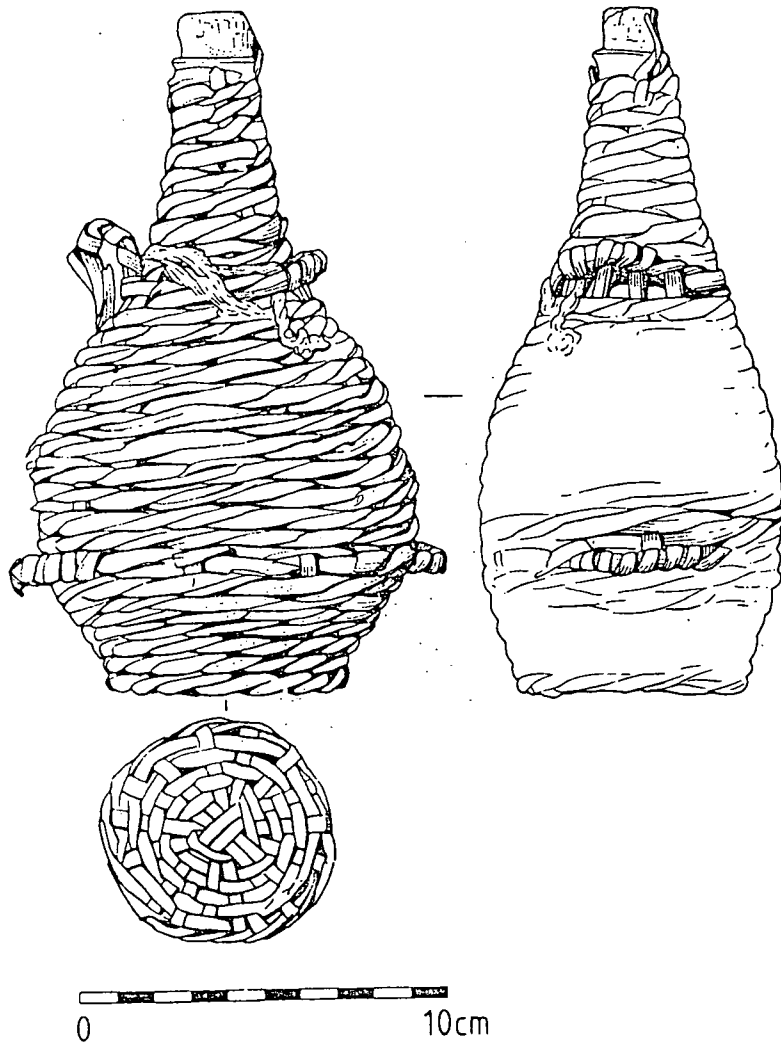

skeumorphic representation of a wicker or straw covering. Sixteenth century probate records refer to '*botels of glasse coverid w'th bull rushes*' and also '*wicker botels*' which are presumably these types of flasks which have a wicker covering to help avoid breakage (Roberts 1992: 13). Indeed a flask of this kind has been found on the Mary Rose wreck which sank in 1536, figure 53 (Elkerton, Pers. Com.). This example appears, although it is hard to tell under the wicker covering, to be a standard flask which is completely covered from top to bottom and has two small loops by which it could be suspended or carried. It is possible that those flasks which were plain are those which might have had an organic covering and the wrythen decorated ones imitated that obvious style. It is not possible at this juncture to prove or disprove this, as the example from the Mary Rose is as yet the only example known archaeologically.

As to the nature of the contents of these flasks, it is hard to assess what might have filled them, although it is possible to say that they are not exclusive to one particular liquid. They are never depicted on the dining table so it is quite unlikely that they held wine, rather more ordinary house hold products. Their occurrence in large numbers from area 'K' in Colchester, a site interpreted as an apothecary, suggests that they were used to hold or dispense pharmaceutical products as well (Chapter 6, fig 42). It is most likely that any liquid that needed to be poured could be placed in a flask such as these.

These flasks were certainly produced in English glass houses. In the fourteenth and fifteenth century Wealden glass houses they are the most common product (Kenyon 1967: 91-99), whilst in the sixteenth century at Hutton and Rosedale they were second only to the beaker in quantity (Charleston 1972: 130 Table 1). It is possible that they were imported from the continent, although their fragility and the evidence for them at production sites would suggest that they were made in England.

Whilst forest flasks are common vessels on any sixteenth century site, better quality soda glass flasks are not. They were also not as long-lived as their forest contemporaries, first appearing in England in the fifteenth century and lasting to the

end of the first quarter of the sixteenth (Charleston 1984: 43-44). Many are of Venetian origin, as the style is found across Europe as long as the Venetians dominated the fine ware market. They differ from the forest versions in a number of ways and are in shape and size more uniform, being referred to by the Venetians as '*Inghistere*'. The rims are usually vertical, with a narrow neck which is longer than the forest examples and usually tapers in slightly to a distinct shoulder (Ibid.). Their bodies are always spherical, whilst the bases are of a narrow pedestal form made by the folding and pushing in of base into a high internal kick. Whilst this form of the vessel is usually consistent, there are a variety of ways that they were decorated. In its simplest form the vessel was left plain, sometimes with only a single thick applied ring around the point where the neck joins the shoulder, figure 52b. Others were decorated in the wrythen style, starting just below the rim and covering the whole vessel. However certain ones were decorated with gilding, often in bands around the neck and pedestal of the flask; this helping to denote the status of such vessels. Later examples are rare and are often more squat, often with the addition of two delicate curving handles attached at the neck and the shoulder. A further function that smaller forms of this vessel might have had, as pure display objects rather than functional table ware, although no vessels of this variation were not found on the five study sites in this thesis. These '*Inghistere*' certainly were used to serve liquids, most often wine, on the table. They are commonly depicted along with other glassware in late fifteenth and early sixteenth century art in this context although they do occur in more domestic scenes as well (Charleston 1984: plate 10b).

In contrast to flasks bottles are not as common in the sixteenth century and conform to a variety of forms. The most well known are the so called case bottles of the late sixteenth and early seventeenth centuries. These were square mould blown forest glass bottles that are assumed by their shape, and due to some examples having scratched sides, to fit into wooden cases (op. cit. 91). These bottles have slightly out turning rims with short necks, rounded shoulders, slightly concave sides and bases that are pushed in with a slight kick. Traditionally these vessels have been regarded as

being blown into a mould up to the level of the shoulder (Charleston 1984: 92). However some of the larger examples have clear broken off large circular pontil marks, which leads to the suggestion that they were made by blowing a cylindrical bottle and this was then flattened on the marving block thus creating the slight concave sides. This is not to say that in the sixteenth and seventeenth centuries moulds were not used for case bottles, indeed this seems increasingly likely that they were used to produce the moulded hexagonal bottles. Charleston suggests that the smaller case bottles were earlier, but what is becoming clear is that all manner of sizes of case bottle were produced in the last quarter of the sixteenth century (Ibid.). These undecorated vessels were certainly made in England as fragments of their bases have been found at later glass making sites (Charleston 1972: 145).

Urinals

Urinals or inspection vessels are traditionally viewed as objects for the practice of uroscopy and indeed depictions of medical practice from the medieval period often showed the use of such vessels (Thorpe 1961: plate 14). Urinals are always made of potash glass and display two diagnostic characteristics which set them aside as a distinct form of flask. The most common evidence from sixteenth century sites are the broad everted rims with a slight upturn on the edge. Some possible rims belonging to urinals have a simpler broad horizontal rim without an upturn at the edge although they are often hard to tell apart from a general flask rim, unless more of the vessel is still preserved.

In a similar fashion the bases of urinals are uniformly similar; indeed it is the convex base with an external pontil mark which is the only certain feature of a urinal. The very bottom of the base is the thickest part of the vessel, partly to ensure strength when the pontil iron is applied but also because that is a natural gathering point for the glass when a spherical shape is blown. As the base curves towards the body the glass becomes correspondingly thin, figure 54a.

Figure 54- Urinal and Lamp.

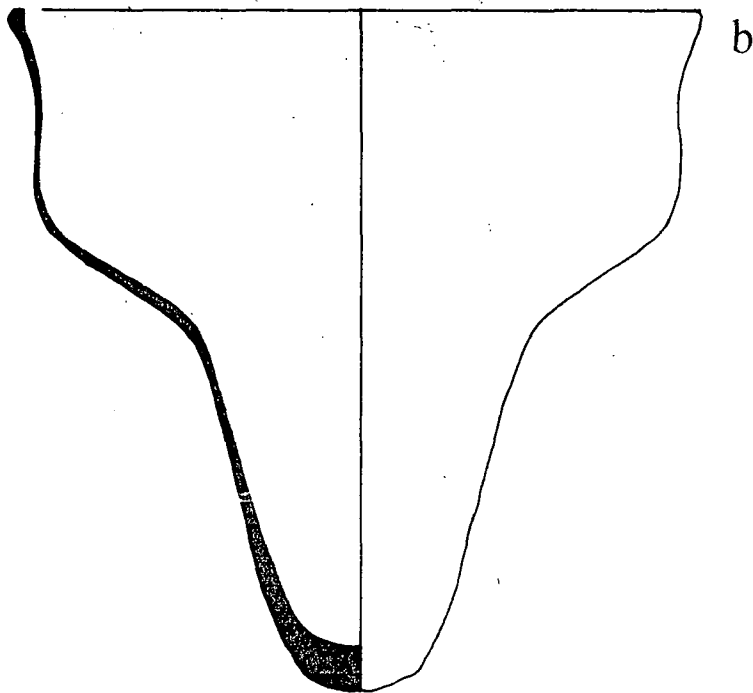
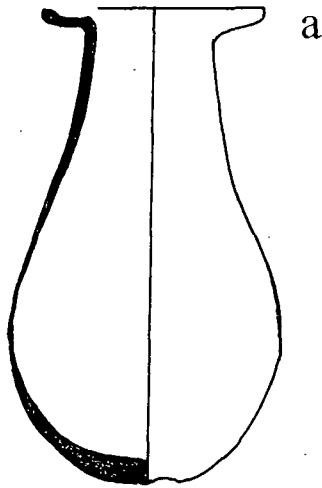

The main body of the vessel is the most elusive element archaeologically, although the one most incorrectly cited in reports. The very function of the urinal as a vessel to view the colour of liquids required the green forest glass to be blown to extreme thinness. Only about a third of the vessel would have been of sufficient thinness to observe the liquid's colour with the minimum of distortion by the glass, this area being between the shoulder and above the base.

Urinals pose a number of problems which has not been helped by the past obsession by glass scholars in identifying every curved body fragment as a urinal. Indeed it is possible to query the very nature of their function. It is certain that some were used for the inspection of urine, as William Vaughn in 1602 suggested that it was common to '*make water in an urinal*' in the morning to aid the assessment of an individual's health (Charleston 1984: 32). This form of vessel could also have been used in any process that necessitated the inspection of any fluid, be it wine or anything associated with medicine. Indeed representations of doctors with urinals could equally show the preparation of remedies, rather than the practice of uroscopy.

The nature of the urinal base makes its own free standing an impossibility and it would thus require either a stand or a case. The latter seems to be the case as Charleston quotes an inventory of Westminster that states that Henry VIII had '*vii cases of wicker two of theym p'telye guilte wth vii brode mouthed Urynalls in theym wth laces of thrid to eache of theym*' (Charleston 1984: 33). This would imply that the vessels were kept in special wicker cases with a thread looped around the neck for suspension or carriage.

However the convex base of the urinal is not necessary for the purpose of inspection and such a vessel would still be effective, and the walls as thin, if it was finished with a pushed in base or an additional base ring. If this is the case then it might be vessels of a flask form could have been used to view the liquid contents and this must be considered. The only definite functional statement that can be made about urinals is that the traditional convex base variety could not have been used as a stable flask or bottle but the reverse is possible with thin blown flasks serving an inspection

function. Urinals were always made from green forest glass and thus thin blowing is required to remove as much colour as possible, but if they were made from a clear soda glass it would be possible to inspect in virtually any shape of vessel and certainly one that was thicker and less likely to break. It is improbable that a person such as Henry VIII would object to paying for a more expensive clear soda glass vessel if it were to aid inspection, especially if he were willing to have two of the wicker cases '*p'telye guilte*' (Charleston 1984: 33). This raises the possibility that urinals do not have to conform to this potash glass model. Having said this there is as yet no identifiable soda vessel which has inspection as its only function.

Lamps

Glass in the sixteenth century was also used to make hanging lamps, a practice that can be traced directly back to the eleventh century in Britain and beyond to the Byzantine and Islamic worlds (Charleston 1984: 30-31). In England lamps were always made from forest glass and thus were blown quite thin to allow for maximum translucency. This form was largely unchanging from the eleventh century onwards and the most complete example of sixteenth century date, from this thesis, is from St. Peter's Street Northampton. Lamps were held by a metal ring below the rim and suspended by three or four chains, whilst the vessel itself acted as a receptacle for the oil and floating wick.

The most commonly identifiable feature of a hanging lamp is the thick walled stub base with an external pontil mark, which like a urinal is rounded, but usually only of a narrow diameter, before it turns sharply into a narrow vertical stem. This part of the vessel is the thickest and thus the most likely to survive when found in archaeological contexts. When more complete examples are found they are of a stereotypical form, where the stem turns out almost horizontally to make a wide bowl before turning again to a near vertical rim of a widely varying diameter, figure 54c. The rest of this body that is hardest to identify as due to their thinness they are rarely found in any state nearing completeness. If only a few fragments of body are found

they can not be distinguished from a flask or bottle, whilst a rim fragment could be of sufficient diameter to be confused with that of a beaker.

When they can be identified hanging lamps are not an uncommon find and the true number of them is probably greater than appreciated. Charleston suggests that their occurrence is greater on abbey sites, but by the sixteenth century there is no evidence for this (Charleston 1984: 31). What is certain is that during the sixteenth century their frequency does diminish and by the seventeenth century there are so far no securely dated hanging lamps. The origins of the form of this particular vessel are obscure in England. The shape of the vessel is similar to the Rhenish funnel beakers of the ninth century, which themselves could have been used for this purpose, although there is no evidence for the typological change that must have occurred over the next two centuries to when the first hanging lamps occur (op. cit.: 10-11 plate 5c).

The fact that these vessels were only made in potash glass is not as surprising as with urinals. It is clear that they were probably designed to throw light downwards as much as up. The green glass and the oil in the vessel would have obscured some of the downward light but it is unlikely that a soda glass version would have been any more affective.

Chapter 8- The Cultural Context of the Glass

The glass from the five study sites is informative in a number of ways and it has already been used to construct a working typology and chronology for sixteenth century glass in chapter seven. However by examining the context of the glass rather than the artifact itself it should be possible to define certain other indications about the way that it was used in a social setting. Most of the recovered glass was deposited on these sites in pits and this allows for the construction of a tentative hypothesis about how the material culture operated within a social system. In this chapter the values and meanings of the drinking vessels are explored. This is because they tended to display more variance and would have been more directly involved with social action than other storage vessels such as flasks or bottles. By identifying aspects of these vessels and their deposition that can be demonstrated not to be the result of random processes, an attempt to assess their place within a constructed social context is possible. However if this approach is to be taken a certain appreciation of the metaphysical value of the object has to be undertaken.

To extract further meaning from artifacts it is important to understand how they were created within a cultural framework and to become as much as possible a user of that social context. To do this it is necessary to explore how social facts exist and how they are instilled and relate to objects. An artifact is purely an object that consists of particles held in force and organised into systems, whether living or dead. The human brain is therefore a biological living object capable of creating intentionality. This intentionality is the ability to represent and recognise objects in the world as well as its self (Searle 1983: 6-7). Thus intentional states are created by the subconscious and if this is understood then it should be possible to account for social facts embodied within the artifact.

Artifacts seem to exist independently of our perceptions of them, but when they are examined they can be seen to contain two types of features, those that are intrinsic to nature and those that are there due to the express intention of the user.

When a glass vessel is considered it has aspects that relate to both these. The constituent elements of soda, silica and oxygen are clearly intrinsically natural, whilst the very term of 'vessel' is using a specific concept determined by the user. Thus in any artifact there is always a multiplicity of user relative aspects and meanings that, although they may not (but more often do) add any physical features, do contribute to more objective features of the vessel.

I therefore argue that artifacts are a combination of naturalist and humanistic values. Certain features of a vessel are intrinsic to nature and are not reliant upon the attitude of the user. However many others are relative to the user and express implicit meanings. It must however be realised that it is not always easy to define those features that are intrinsic to the artifact or to social construction. With a glass vessel it would be possible to argue the existence of colour on both these points. Colour could be perceived as the intrinsic result of the mixing of the natural ingredients with their respective impurities, which causes an unintentional colour such as the green colour of forest glass. Alternatively colour could be perceived as a deliberate feature added in the process of glass making with intent to convey a social meaning.

Four distinct features are observable in the deposits from the five study sites in this thesis and each of these shall be examined separately for any reflections that they may have on the value and use of the glass in the sixteenth century. Firstly there are observable anomalies in the types of vessels made in glass, these being almost exclusively drinking or storage vessels. Secondly there appears to be some variance in the proportions of soda to forest glass within these drinking vessel categories, perhaps suggesting different values of status and wealth. These first two peculiarities are observable within the artifact itself, however the second two are derived from the contexts that they were found in. Several of the pit groups seem to indicate that there was the deposition of a large number of drinking vessels in one action. This contrasts with other forms of vessels that seem often only to appear as part of the general make up of a rubbish pit. The third contextual development is that, with the exception of Southampton, all the large groups of glass appear to have been deposited in the second

half of the sixteenth century. This seems to indicate an increased demand for, and access, to glass as a medium to be used for consumption. However this apparent increase in the observed consumption of glass might be the result, in part, of a shift in the patterns and attitudes of discard.

a) Glass Vessel Types

Glass has the almost unique ability to be formed into any shape required for vessel shapes and certain display pieces from the sixteenth century demonstrate this, (Tait 1991: chapter 5). However the glass from the five study areas all falls into two categories, drinking vessels and storage or serving containers. Into the first category are the beakers and the goblets, which between them are probably the most common finds, although this might be a biased result. Flasks and bottles can be considered as storage vessels, even if this is only for a limited period of time. Between the two vessel types falls the jug, an uncommon type, where liquids are not directly consumed from this vessel, but they are placed in it so that they can be poured into another consumption vessel. However what unifies all categories of these vessels is the fact that they were made and used to handle liquids. This is not to say that dishes and bowls are not known from this period, with a single deposit from Norwich containing nine, but they are very scarce and more the exception than the rule (Margeson 1993). The reason for this is unclear. Glass in other periods successfully fulfilled these roles, so it is most likely to be a consequence of fashion. (Bowls are quite common in Roman contexts with pillar moulded varieties in the first century A.D. and plain hemispherical ones in the third and fourth centuries, Cool & Price 1995: chapter 6). Glass did offer distinct advantages over other mediums in holding liquids, being completely impermeable, easily cleaned and with no taste of its own. These are all properties ideally suited to liquids. Additionally being translucent it was possible to completely contain the liquid, and yet still display it, a property more suited to vessel forms associated with liquids. Consequently the use of glass in the sixteenth century exclusively for liquids could be seen to be a functional result, rather than from any

socially motivated cause. However the unique property of the translucence of glass allows for the liquid being held to be viewed. The advantages of this are clear, the purity and the quality of the liquid to be consumed can be easily displayed. However it also has a more symbolic function. If glass is used for the exhibition of its contents, then the contents themselves are given further meaning. Not only does the liquid itself become an important part in the decoration of the vessel it gains an importance over the vessel. The vessel is perceived as a secondary vehicle to the liquid.

b) Variation Between Vessel Type and Metal

Within the category of drinking vessels there would appear to be a variation between the type of the vessel and the nature of the glass, whether this is soda or forest glass. Both beakers and goblets are made in both metal types, but the proportions of these types recovered do vary. In Northampton, Oxford and Winchester of all the beakers recovered, forest types are the most common. The reverse is true at Southampton and Colchester where soda varieties dominate. However when the proportions of soda to forest types are examined in terms of the goblet, all five study areas show a domination by soda examples. This apparent favouritism of soda beakers in both Southampton and Colchester is possibly explained by their geographical location. Both these towns occupy locations associated with foreign trade and thus presumably had a greater access to imported soda glass (Platt 1975: 35-36; Britnell 1986: 4-5). There are several social explanations for the discrepancy between metal type and vessel form.

Beakers occur in almost all contexts in these study areas, from the suburbs of Winchester to the merchant houses of Southampton. It would appear that all levels of society were using these vessels for the consumption of beer (van Dongen 1994: 14). It could be possible to suggest that forest beakers represented the vessel of the poorer elements of society and the soda beaker the higher. This however is clearly simplistic as ordinary forest beakers appear on the same sites as the highest quality ones. This would tend to suggest that in the higher status properties there were two sets of

beakers, possibly with the soda ones being part of 'the best set'. Roland Barthes suggests that the modern day concept of superiority in food stuffs is one way that food and dining can impart different meanings to the users (Barthes 1979: 166-173). These superior or inferior expressions are not only indicated by the food and drink but also by the vessels associated with the comestibles. Therefore it would not be unreasonable to suggest that the presence of forest beakers on higher status sites reflects the ordinary glass used, whilst the soda examples were reserved for occasions which required conspicuous display. Presumably the lack of soda goblets on sites in Northampton and the Winchester suburbs indicates that either this concept was not continued further down the social scale or that the occupiers were aware of the ideas, but did not have the resources to obtain such vessels.

If there is the indication of a general preference towards forest varieties of beaker, this is certainly not the case for goblets. There has been a bias shown towards the prominence of the forest goblet (Charleston 1984: 89-90), primarily due to the remains of them at the glass houses at Hutton and Rosedale (Charleston 1972: 148) and the well known glass hoard from Gracechurch Street in London (Oswald 1949). From the five study sites the frequency of this form of goblet was exceptionally low, although the problems of identification have been discussed in this thesis in chapter seven, with only the fragments of two having been positively identified. On the sites that did produce goblets these were almost exclusively of soda glass. Goblets as a whole were not as common as beakers, possibly suggesting that there was less consumption of wine. The indication seems to be that if wine was consumed a soda vessel was generally used, even in the context of an inn, such as the material from The Bear in Oxford and The Falcon in Colchester. The reason for this might be in part due to status. It is possible that wine in this period was an expensive commodity and to emphasise this it was drunk from a soda vessel. Alternatively it is possible that a clear soda goblet was used to show off the colour and clarity of the wine, in the same fashion as the majority of modern wine glasses are clear. Whatever the solution to this

variance in the metal used to make beakers and goblets, it will only become apparent with further work.

c) Group Deposits of Drinking Vessels

Several of the pit features associated with buildings from these study sites contained evidence for the deposition of large groups of glass, and some times pottery, drinking vessels. The pit cut into House 7 at St. Peter's Street in Northampton demonstrates this, where out of a half excavated pit the remains of three glass and six pottery beakers and mugs were found. Other sites such as the Bear Inn at Oxford, House 9 at St. Peter's Street, Northampton and the excavations at Middleborough, Colchester all showed similar depositions of large groups of drinking vessels in one action (although the contexts at Middleborough are very confused, it is still likely that the remains of the four *Wafelbekers* were originally from a single context).

An easy interpretation of these groups is not possible, but there are a number of possibilities that could explain this apparently intentional act. The vessels being disposed of are all of around the same date, and indeed in the case of Middleborough the same form. This dumping of glass and sometimes other vessel types together might represent the clearing of an old existing table set to make way for a new one. The deposit from St. Michael's House in Southampton, which comprised of two goblets, a jug and a container were almost certainly deposited in their stone lined pit whilst whole. Indeed this high quality group might be indicative of a complete set, a pair of goblets with their jug. Whether the quality of the glass is high or low and seemingly irrespective of the status of the site, there appears to be conscious throwing away of groups of beakers and goblets, probably when they were still usable.

There are two possible explanations to this clearance of vessels, the first being a change in style and the second for more symbolic reasons. It could initially be suggested that the deposition of these vessels was the result of them seeming out of date or unfashionable. They could have been, and in the case of the Northampton groups probably were, several years old on deposition. In this instance this might seem

a reasonable explanation, although such wasteful destruction of vessels might seem odd in a period when items in the home are far more uncommon in the sixteenth century compared to later ones (Johnson 1996: chapter 8). Additionally many of the styles discarded during the last quarter of the sixteenth century continued to be produced in the following one, such as forest pedestal beakers and soda lion mask stem goblets. Consequently it would seem not to be the case that the deposition of the vessels was the result of a change in glass styles.

It is probable that another more symbolic cause is in operation which produces these deposits. Vince and Bell suggest that pottery table wares do seem in some instances to have deliberate short lives and are discarded when still in perfectly good order (Vince & Bell 1992: 101-112). They cite the example of Acton court, where an apparent table set was disposed of soon after a visit from Henry VIII and this same site also displayed a mass dump of glass (Courtney 1991: 125). This is also seen in the late sixteenth century with the apparent destruction of a set of glass at the moated manor of Wood Hall in Yorkshire, which is interpreted as having been thrown out of the hall window into the moat (Metcalf V, Pers. Comm.). However, with the exception of Canons Ashby in Northamptonshire, none of the study areas produced evidence for buildings of the same status as Acton Court or Wood Hall. Nevertheless there seems to be the same trend occurring on these sites, albeit on a lesser scale, and was probably motivated by the same ideals. What these were is uncertain, but they seem to be an English phenomenon, as in 1617 Venetian ambassadors on visiting the court of James I were shocked by the wilful destruction of glass (Johnson 1996: chapter 8) The cultural factors behind this wastage of material are very unclear, although this is a pattern not only confined to glass as large deposits have been noted in assemblages of pottery (Gaimster 1994: 295). Indeed pit C63 from House 7 at St. Peter's Street not only contained evidence for the dumping of glass beakers but also six pottery tankards and a Belarmine jug. Quite clearly there are cultural factors in operation which affect the general attitudes to discard in a manner that seems almost ritualistic.

d) The General Increase in the Use of Glass from 1550 Onwards.

Southampton is the only site examined that produced a significant quantity of material from the first half of the sixteenth century, and even here this was relatively small compared to the later material. When all the sites are considered it is quite curious that there is an absence of glass drinking vessel forms found in England in the middle of the sixteenth century, although home produced flasks, lamps and urinals seem to continue. There are some notable exceptions, such as the glass from Acton Court, although these seem to be limited to high status sites (Courtney 1991: 125). Traditionally scholars such as Charleston and Godfrey have assumed that the lack of glass from this period is due to the fact that glass making in England no longer existed in the early sixteenth century and was only reinstated by immigrant glass workers from the 1560's onwards (Charleston 1984: 53; Godfrey 1975: 16). The documentary evidence for this is in some respects clear, and chapter 1 outlines some of the sources that suggest that immigrant workers were actively encouraged because glass making in England had ceased to occur. Archaeologically this is partly confirmed, no glass house has been positively identified by excavation to date from between 1525 and 1575 and certainly the amount of presumably home produced forest glass is much less than the previous two centuries (Charleston 1984: 87).

However the lack of the production of glass made in England does not explain why glass is not found in any great quantity on English sites in this period. Just because native production was not occurring, this would not have prevented the use of large quantities of foreign glass. It would seem that there was not the large market for glass that existed in the latter sixteenth century. Gaimster points out that there was a wider range of materials used at the table in the second half of the sixteenth century (Gaimster 1994: 295-296) and illustrates this with the glass found in the stone lined pit at Honey Lane, London (Hume 1962). He however suggests that vessel glass is absent from many areas in the second half of the sixteenth century, and attributes this to its 'relative social exclusivity' (Gaimster 1994: 295). The results from the areas investigated in this thesis contradicts this idea of exclusivity, with groups of glass

occurring in the last quarter of the sixteenth century in all five. It is the underlying reasons for the apparent increase in the range of table vessels in the second half of the sixteenth century that might explain why glass appears to increase in use from 1550 onwards. It is probably more linked with the changing nature of the role of the dining ritual, rather than the use of glass being encouraged by a native production in England.

e) Social Theory and Dining

Mary Douglas, the contemporary anthropologist, argues for food and dining as being a symbolic system of communication, where life is ordered and this penetrates all social action and activities. She states that 'Food is the medium through which a system of relationships within a family is expressed.' (Douglas 1982: 86) This view, if an oversimplification of her argument, suggests that food is expressive communication within a social circle. It is easy to expand this argument to encompass the whole ritual of dining to include not just food but the material culture involved. The Douglas' argument would suggest that vessels connected with dining are a positive action of expressive communication. If so then the roles of artifacts and glass in particular, have to be examined in terms of communicative objects when viewed in the setting of a meal. It is therefore important to try and interpret the various elements of that active dialogue which can hopefully be defined from the table setting.

Status is a concept that is widely interpreted in artifact studies and is often clearly seen as a communicated expression in the archaeological record. The artifacts placed around and in the table setting were ideally suited to express these kinds of meanings, as the dining table was not just the arena for family but also guest entertaining. Wealth expressed in objects is one of the more obvious expressions of status embodied in the artifact. The number of vessels present is an apparent expression of wealth and it is clear that during the course of the sixteenth century more and more vessels were used for the consumption of food, particularly on the

Figure 55- Sir Henry Unton's Feast



personal level. Depictions of late sixteenth century meals, such as the feast scene in the engraving of Sir Henry Unton's life, inevitably show a full set of plate, glass and utensils for each person, figure 55 (Girouard 1978: plate 7).

It is all too easy to equate wealth, status and class in the same category and this division is far too simplistic. The expense of an object does not necessarily confer a status judgement. The sixteenth century was a period of hierarchical development and change from what we perceive today as a feudal system where wealth and power were based in land to an order where materiality did not directly infer status or class (Girouard 1978: 2-3). During the sixteenth century the urban middle class had no set role and it is from these contexts that most of glass examined in this thesis comes from. Although not all glass can be considered of a high 'status' the care taken and obvious workmanship involved in the production of such material must be relative to a value based on its quality. This would inevitably create an element of expense associated with the vessel, which in turn confers a status judgement in terms of wealth over the person who owns the glass. The expense of the glass vessel is not entirely determined by cost of its production, the rarity of its access also plays an important part. Therefore when William Cecil granted the Queen's monopoly in 1574 to Jacob Verzelini for production of Venetian style *Cristallo* glass, the genuine article was banned from import (Godfrey 1975: 29-30). Although this ban may have not been totally upheld and Venetian glass could be brought back by individuals for their own use it would have had the effect of limiting the quality glass market to only that which Verzelini produced in London (op. cit.). Consequently the conspicuous use of glass at this time at the table would have had the effect of making a status comment about the owner's status. Indeed if Venetian glass was used when its importation into England was meant to be prevented, this would have given the image of power to the household which still had access to it.

The final element that would be explicit in terms of 'status' in glass is its fragility and dispensable value. Glass as a vessel type has one major disadvantage, that being it is extremely fragile and once broken hard to repair. The glass from this period

seems never to have been repaired, although whether this was due to the loss of its value or the technical problems involved is uncertain. Thus in a situation where glass is handled frequently breakage is quite likely and if an investment of money is placed in these vessels it is likely to be lost in the long term. In any terms this shows a conspicuous destruction of wealth, compounded by the fact that glass as a raw material held little tangible value, as opposed to gold, silver or even pewter which could be melted down and reused. Glass was therefore an ideal material through which more complex ideas of communication could be developed at the table.

Roland Barthes sees dining, and therefore the artifacts used at the table, as signifying cultural meanings to those who engage in it (Barthes 1979: 166-173). He recognises that not all varieties of food are necessarily significant at a collective social level, and if this is applied to material culture allows some variance for personal taste. He finally concludes that food in itself rarely signifies anything and that it is only through its preparation and presentation that it acquires meaning. It is therefore the use of artifacts, such as glass, at the table that not only gives meaning to food but also the whole dining ritual. However Barthes recognises the variance of dining preferences within different social or class groupings and these produce the varieties found in the material culture.

Both Douglas and Barthes suggest that the dining ritual is an important vehicle in the expression of communications and cultural meanings. However further evidence is required to substantiate the claim that the sixteenth century saw the transformation of the communal feast into the complicated dining ritual. Yentsch has related pottery vessels from high or courtly cuisine with low or folk cuisine from the Atlantic seaboard of America in the seventeenth and eighteenth centuries. She was able to observe social change in culinary practice and particularly noted an increased emphasis on serving vessels and the transition from communal drinking vessels to individual ones. These changes are interpreted as having occurred first in English and European families from the sixteenth century and then spread to these areas of Maryland and Virginia (Yentsch 1991: 25). However it still has to be asked that if a

change in the dining ritual did occur in this period and if this is reflected by the increased use of table vessel, including glass, why did it occur? This may be partly explained by the presence of documented social controls added to consumption in the sixteenth century. These rules were expressed in the form of manners and the concept of civilité. The most influential writer on manners in the sixteenth century was Erasmus of Rotterdam who in 1530 published his pamphlet '*De Civilitate Morum Puerilium Libellus*' (Elias 1978: 53). Erasmus was by no means the first to write such a treatise, other similar rule books were written already. As early as 1141 Hugh of St. Victor had written '*De Institutione Novitiarium*' (op. cit.: 60). Indeed there are a series of poems from the fourteenth and fifteenth centuries which express a similar oral tradition of instruction for the elite into behaviour at the table (Elias 1978: 61). Erasmus wrote a composite of these earlier traditions and reworked the material, saying that signs, gestures and conduct were a direct mirror to the soul, and that through social action people are judgeable. However Erasmus was innovative in a number of ways. His work was addressed to '*Puerilium*' or children, suggesting that manners should be taught at the youngest possible age. He also addresses for the first time all children, it is not a specific work for the nobility or clerical circles. This suggests that manners and the concept of civilité were extending further down the social scale than previously. Erasmus sought to use a common code that could apply to every one as a way of establishing a social identity through manners, although it probably still would only have affected the upper classes (Elias 1978: 54-55). Finally Erasmus succeed where earlier attempts had failed because his was the first secular version and he published his work not long after the invention of mass printing, allowing a wide circulation of his work. This was demonstrated as his treatise went through eighty editions and was translated into fourteen languages (Revel 1989: 172).

This had an enormous impact in terms of social identity through dining. Not only did Erasmus and other writers discuss personal behaviour but also the way the individual should conduct themselves during a meal. This would suggest that the concept of civilité seemed to have applied at the top end of the social spectrum and

most probably in the aspiring middle classes, although there is no direct evidence for this. This would have produced an increased perceived control whilst at the table, at several levels of society. For the first time the use of artifacts was strictly regulated at the table, not just at the highest elite levels but also more widely where Erasmus' work was circulated (Ibid.). These manners were formed not only to help the inexperienced person at the table but also to create a social stability and order. Such regulations are straight forward and clear, probably prompted other subsequent publications. In 1560 C. Calviac wrote 'Civilité' and stated '*puis il mettra son pain de costé gauche, le cousteau du costé droit, comme le verre aussi*' (then he shall place his bread on the left and the knife on the right, like the glass) (Elias 1978: 271). Likewise 'S'ensuivent les contenance de la table' gives the instruction '*Enfant, se tu fais en ton verre soupes de vin aucunement, boy tout le entierement, ou autrement le gecte à terre*' (Child, if you put bread crumbs in your wine glass, drink it all entirely, or throw it on the ground), (op. cit.). Consequently the table and the artifacts involved with the dining ritual are being used to educate and reinforce elements of social discourse and identity.

This chapter has attempted to address a number of the issues raised by the apparent trends in the distribution of the glass found at the five urban sites. The issues of the types of glass found, the variance of metal type, the apparent groups of deposited drinking vessels and, most importantly, the general increase in the use of tablewares in the later sixteenth century have been addressed. However these conclusions are limited in their application and the general problems with such an approach are discussed in the conclusion. However this study serves as a preliminary investigation of the social value and role of vessel glass in the sixteenth century.

Chapter 9 Conclusion

This thesis has endeavoured to undertake a preliminary study of vessel glass in the sixteenth century and the contexts in which it was used. For this purpose five study areas were examined and groups of glass from a variety of sites recorded. These areas covered mainly the south eastern portion of England and enabled a considered approach as to what types of glass were used and what value they might have had in sixteenth century society. This study has several limitations and these should be fully explored. However it has achieved the majority of its aims and further research into this area will not only add to our knowledge of the glass used in England, but also to its social value.

The sixteenth century was chosen for this thesis for two main reasons. As Charleston acknowledges comparatively little is known about the glass from this period, with more information being forthcoming from documents rather than archaeology (Charleston 1984: xxviii). An archaeological survey of glass from the sixteenth century has been long overdue and this thesis attempts to address this imbalance. This is important as historically the sixteenth century appears to see the establishment of a native glass industry, which had apparently disappeared previously and also was the time when vessel glass became widespread in use throughout society (Ibid.). The sixteenth century was also a period of great change historically and archaeologically generally, being the century when England is viewed as having turned from a medieval state into an early modern one. A number of important changes in both philosophy, theology and state were taking place to such an extent that all levels of society were likely to have been affected (Mackenny 1993: 3-5). This is the second reason why this period was chosen for this thesis, as it was hoped that these underlying social changes might be visible through, and reflect, upon the glass from this era.

During the course of this research it has become apparent that the period delineation's used are not entirely suitable. Temporally the sixteenth century is a

convenient period to encompass a study as the Tudor dynasty is closely associated with it. However it is clear from the results of this study that the sixteenth century is not a completely satisfactory interval and from the perspective of the glass a later end date would have been more appropriate. This is for two reasons. Many of the traditional forest glass forms, such as the flask, produced throughout the sixteenth century continue into at least the first quarter of the seventeenth century. In a similar fashion many of the soda glass forms of goblets and beakers were apparently used until the mid seventeenth century. If a historical end date is to be chosen, then the start of the English Civil War would seem most appropriate, although whether this event directly caused the changes in the glass types or they merely coincide is uncertain.

The second major limitation of this survey comes from the nature of the sites explored, they were all from urban contexts and contain all the problems associated with this type of archaeology. This thesis attempts to undertake a study of the glass used at all levels of society, and to some extent is successful. However due to the nature of the urban population in the sixteenth century it is not entirely possible to see the glass that was used in the highest levels of society. The five study areas were all provincial towns with their poor and urban middling classes, but few reflect structures and therefore glass relating to the elite. This is demonstrated by the glass found at Northampton which was almost all of the forest glass variety and of unremarkable forms. However the glass from Canons Ashby, demonstrates that when specific sites outside the urban area are also examined, a more complete picture can be achieved. This survey does not take into account the fact that both the town and the countryside operated within a cohesive system. Consequently in any further study glass must be examined not only from urban contexts but also high status rural ones.

Further problems arise out of using data from urban excavations. This thesis has tried to undertake a close contextual approach to the material examined. To this end the glass is examined not only as an independent artifact but also in its wider setting on the site. To enable this to be done a high level of contextual evidence from the various excavations needs to be available, and this is not often the case. It is

interesting to contrast the material from Northampton with that of Colchester, in the results that they achieved. The material from Northampton was excavated in a manner that allows detailed analysis and hypothesis, the hoard of glass and pottery drinking vessels cut into House 7 at St. Peter's Street illustrates this. By comparison the post medieval material from Colchester, by the excavators own admission, was often partial and very poorly recorded (Crummy 1992: 1-2). Consequently the site at Middleborough in Colchester produced a collection of four very similar *Wafelbekers*, which might well have come from a significant deposit, although it is now not possible to tell whether this was the case or what other associated material was found with them. This highlights one of the major problems with rescue urban archaeology, that the post medieval features are often poorly recorded and much valuable information lost. A further study would benefit from consideration of rural sites which have been chosen because of the nature of the site and also the manner of its excavation.

The final major limitation of this thesis is in the area that it covers, with all five sites being clustered around the South East of England. This was due, in part, to the apparent large quantities of material in these regions, although this might equally reflect the amount of excavation undertaken. Consequently the results from these five towns should be treated cautiously if provisional assumptions are to be made about the use and value of vessel glass in sixteenth century England. London as an area needs to be considered as well, if the assumption that the changes in fashion were initiated by the elite of society in the capital is to be examined. A further extension to this problem is that imported vessels are not fully understood, as they are only considered by their location on sites in England. Much of this material is not fully comprehended in terms of origin and date and further study of the imported glass in the context of its own country of manufacture, needs to be done. Social trends in Northern Europe are particularly of interest in this thesis as it has become apparent that more material from this area was being used in England than the traditional emphasis on Venetian products had first assumed. In a similar fashion it is not known

to what extent English products were exported abroad, if at all, and examination of the glass from continental sites would answer such questions. It is also important to extend this survey abroad if the social value of the glass used in England is to be set in a wider European context. Values that could be assumed, concerning the status and role of glass in England, might not correspond in the Low Countries. To this end good deposits of glass from well excavated continental sites need also to be examined in conjunction with those from England.

Despite the limitations outlined above, this thesis has succeeded in achieving most of its aims as a preliminary study of sixteenth century glass. A working typology has been produced which, although it is by no means complete or firm, acts as an initial step in understanding the types of glass used in England. For these purposes the glass has been examined successfully, known types have been established and a framework for more detailed research achieved. The most important result of this typology is to emphasise the importance of quality soda glass from Northern Europe which, although it has been recognised in its own right before, has never received the attention due to it. (Thorpe 1961; Charleston 1984; Tait 1991; make little reference to these types of glass). The establishment of a typology has only been possible by the examination of material from excavated sites that can produce the contextual information to its chronology and usage. This approach also allows the glass to be viewed in association with the structures and society that it related to, thus creating the opportunity for the realisation of its social value. This has been undertaken in a limited form, based on these sites and the certain trends identified. The disposal of groups of drinking vessels seems to occur on most sites and is indicative of a wider social process. The destruction of vessels, which sometimes appear to have been complete and of forms that were still fashionable, is initially explored in this thesis. Other aspects, such as the exclusive use of glass for liquids and the apparent large increase in its use in the second half of the sixteenth century are also addressed.

However this is only an initial study and for broader conclusions to be reached further research is required.

To achieve a more balanced picture of the glass used in this period and its social value, future research needs to be directed in a series of ways. The date ranges for the forms of glass discussed still need to be refined by the examination of more material from selected sites with well established sequences. A more complete range of sites, in terms of status and location, need to be considered, especially those relative to the higher levels of society, with rural manors and urban palaces requiring particular consideration. The glass from excavation is the most important way that these objectives can be fulfilled, but additional evidence needs also to be considered so that a more rounded approach can be taken. Contemporary sources and accounts of the role of objects or the way that social relationships were conducted need to be contemplated, as they offer a potentially important perspective of sixteenth century attitudes to glass and society. The study of probate inventories could allow for analysis that archaeology rarely can provide. Most of the material came from contexts where it had been disposed off, but by indicating where in the house the glass was used further cultural values can be seen. This could be further supplemented by the close study of pictorial representations of glass, which should improve the type series and indicate further values of the glass by the way that it is depicted.

These considerations for further research would not be possible without the underlying work undertaken in this study. This is a one year thesis and all these ideas could not be explored. However it has achieved its main objectives and allows for a subsequent detailed survey of not only what glass was being used in this period, but also its context within society.

A Glossary of terms used to describe glass

Base Ring. A ring of glass, usually solid, applied to the base of the vessel, often more for decorative rather than stability purposes.

Blowing. The principle technique of fashioning a vessel by inflating a gather of glass on the end of a blowpipe.

Blowpipe. A tubular metal pipe with a wooden holding end, for the inflation of glass.

Cane. A collection of thin glass rods which are fused together to produce a multicoloured rod.

Combing. A decorative technique where by either decorative bands of glass or two applied sections of a vessel are dragged across each other with a sharp tool.

Cristallo. A type of soda glass, first created in Venice in the fourteenth century, but by the sixteenth was the standard soda metal.

Cullet. Scrap glass from old vessels collected by the glass maker for recycling.

Diamond Point Engraving. The technique of shallow cutting the surface of the vessel with fine incised lines to produce a pictorial representation. This engraving is assumed to be carried out by a diamond point, but flint could also have been used.

Enamelling. A technique by which the vessel is decorated by the application of 'painted' decorated which is then fused in the furnace.

Façon de Venise. The traditional term used by art collectors for the high quality soda glass made in Northern Europe, originally thought to be the deliberate copying of Venetian styles.

Filigree. A decorative technique by which numerous very fine, usually opaque white, threads are marvered into a vessel.

Forest Glass. A type of glass, traditionally made in wooded areas, which uses a potash base from burnt wood as its alkali. Usually green in colour, it weathers easily in archaeological contexts.

Gather. The portion of molten glass on the end of the blow pipe which is subsequently inflated.

Kick. The convex point of the base which is pushed in by the pontil iron.

Knop. A decorative bulge on the stem of a glass, either hollow or solid and of varying shape and sizes.

Knobbel. An optic blown decoration in the form of rounded blobs, usually appearing on vessels from the Low Countries

Ladder Stem. A form of a fixed two piece mould blown stem. Decoration consists of usually four sets of vertical rows of protruding quadrilateral pyramids, the gaps between these resembling a ladder. Between these vertical ladder rows are usually panels of scrolled decoration.

Lattimo. A decorative technique originally developed in Italy. Derived from the word for milk it describes any applied or cane decoration which involves opaque white strips

Lion Mask. A form of a fixed two piece mould blown stem. Decoration consists of two frontal lion faces, one from each half of the mould, with tear drop decoration above and below.

Marver. A flat surface or block used to roll the still fluid glass on the end of the blow pipe to smooth the vessel or press in any applied decoration.

Metal. An ambiguous term, but used here to refer to the make up of the glass, much in the same way as the term 'fabric' is used in pottery description. Usually used to differentiate between forest and soda glass.

Mould Blowing in a two piece mould. The further inflation of a parison of glass into a fixed two piece mould. The glass is pressed against the side of the mould assuming its shape and is only removed when it is cool enough to hold its new form.

Optic blowing. The further inflation of a parison of glass into a one piece optic mould so that the incised decoration of the mould is pressed into the glass. The parison is removed and the further inflated and worked, so that the final vessel is decorated with an expanded and altered variation of the original decoration.

Parison. The gather on the end of the blow pipe which is already slightly inflated.

Pontil Iron. A metal rod which is applied to the base of a vessel with a lump of glass during manufacture, usually so it can be held to form the rim. When removed it leaves the slight remains of a pontil mark.

Prunt. Decoration consisting of an applied blob of glass. These can be further manipulated by pulling or in the case of wine bottles, stamping.

Soda Glass. A type of glass traditionally associated with the more skilled glass works which uses soda as its alkali. Usually colourless unless a colourant is added.

Trail. A thin strand of glass, circular in section, which is applied to the face of a vessel as decoration.

Wafel. A decorative technique by which the parison of glass is decorated with a spiral trail and then blown into a vertical fluted optic mould. When the parison is removed it is inflated and formed into a vessel, usually a beaker. The resultant decoration takes the form of a cut or chequered trail. Usually associated with the Low Countries.

Wrythen. An optic blown decorative technique, commonly used on English forest glass. The Parison is blown into a vertical fluted optic mould and removed. As the parison is inflated to form the vessel it is twisted to produce the characteristic wrythen spiral affect.

Bibliography

Works Referenced in the Text;

Albrizzi, A. (1982) Mille Anni di Arte de Vetro a Venezia. Museo Correi, Venezia.

Audouy, M. (1991) "The Priory Church of St. Mary, Canons Ashby".
Northamptonshire Archaeology (28). 57-67.

Barthes, R. (1979) "Towards a Psychosociology of Contemporary Food Consumption" in Forster, Ranum eds., Food and Drink in History. John Hopkins University Press, Baltimore. 166-173.

Biddle, M. (1990) Object and Economy in Medieval Winchester Vol. 1&2. Clarendon Press, Oxford

Braumgartner, E & Kreuger, I (1988) Phoenix aus Sand und Ashe. Klinkhardt & Biremann, Munich.

Brears, P. (1985) Food and Cooking in Sixteenth Century Britain, History and Recipes. English Heritage.

Britnell, R. (1986) Growth and Decline in Colchester, 1300-1525. Cambridge University Press, Cambridge.

Britnell, R (1988) Colchester in the Early Fifteenth Century. University of Durham, Durham.

Buckley, F (1925) A History of Old English Glass. London

Charleston, R (1972) "The Vessel Glass from Rosedale and Hutton" in Crossley & Aberg "Sixteenth Century Glass Making in Yorkshire, Excavations at the Furnaces at Hutton and Rosedale, North Riding, 1968-71". Post Medieval Archaeology 6. 128-150

Charleston, R (1984) English Glass and the Glass Used in England circa 400-1940. Allen & Unwin, London.

Charleston, R (1990) "Vessel Glass of the Late Medieval to Modern Periods". in Biddle ed. Object and Economy in Medieval Winchester vol.II. Clarendon Press, Oxford, 943-947.

Cool, H & Price, J (1995) Roman Vessel Glass from Excavations in Colchester 1971-1985 Colchester Archaeological Reports 8

Courtney, P (1991) "Venetian Glass from Acton Court". in Starkey ed. Henry VIII: a European Court in England. Collins & Brown, London. 125.

Crossley, D, Aberg, F (1972) "Sixteenth Century Glass Making in Yorkshire, Excavations at the furnaces at hutton and Rosedale, North Riding, 1968-71". Post Medieval Archaeology 6, 107-159.

Crummy, P (1984) Colchester Archaeological Reports 3; Excavations at Lion Walk, Balkerne Lane and Middleborough, Colchester, Essex. Colchester Archaeological Trust.

Crummy, P (1992) Colchester Archaeological Reports 6; Excavations at Culver Street and the Gilbert School and Other Sites in Colchester 1971-85. Colchester Archaeological Trust.

van Dongen, A, Henkes, H (1994) Gebruiksglas in Beeld en Verbeelding. Museum Boymans van Beuningen, Rotterdam.

Douglas, M (1975) "Deciphering a Meal" in Douglas ed. Implicit Meanings. Routledge and Kegan Paul, London. 249-275.

Douglas, M (1982) "Food as a System of Communication" in Douglas ed. In the Active Voice. Routledge and Kegan Paul, London. 82-104.

Elias, N (1978) The Civilizing Process; vol.I, The History of Manners. Blackwell, Oxford.

Elias, N (1991) The Society of Individuals. Blackwell, London.

- Gaimster, D (1992) "The Publication of Finds from Winchester Reviewed". Medieval Archaeology 36. 309-14.
- Gaimster, D (1994) "Post Medieval Society." in Vyner ed. Building on the Past. Royal Archaeological Institute, London. 283-312.
- Girouard, M (1978) Life in the English Country House. Yale University Press, Yale.
- Godfrey, E (1975) The Development of English Glassmaking, 1560-1640. Clarendon Press, Oxford.
- Goetz, B (1990) Verrerie de L'Est de la France, XIIIe-XVIIIe siècles. Revue Archéologique de L'Est Neuvieme Supplément.
- Halliwell, J (1854) Ancient Inventories. London
- Hartshorne, A (1968) Antique Drinking Glasses, A Pictorial History of Glass Drinking Vessels. 2nd ed. Brussel & Brussel, New York.
- Hassall, T, Halpin, C, Mellor, M (1984) "Excavations at St.Ebbes, Oxford, 1967-1976: Part II, Post Medieval Tenements and the Post Dissolution Site of the Greyfriars". Oxoniensia 49. 153-276
- Henkes, H (1994) Glas Zonder Glans, Vij Eewen Gebruiksglas Uit de Bodem van de Lage Landen 1300-1800. Rotterdam Papers 9
- Hume, I (1962) "Tudor and Stuart Glasses Found in London". The Connoisseur September 1962. 269-273.
- Hurst-Vose, R (1980) Glass. Collins, London.
- Hurst-Vose, R (1994) "Excavations at the Seventeenth Century glasshouse at Haughton Green, Denton near Manchester". Post Medieval Archaeology 28. 1-72
- Johnson, M (1996) The Archaeology of Capitalism. Blackwells, Oxford.
- Keene, D (1983) Survey of Medieval Winchester vols. I&II. Winchester Studies 2.

Kenyon, G (1967) The Glass Industry of the Weald. Leicester University Press, Leicester.

Levi-Strauss, C (1965) "The Culinary Triangle". Partisan Review 33. 586-595.

Mackenny, R (1993) Sixteenth Century Europe, Expansion and Conflict. Macmillan Press.

Moorhouse, S (1971) "Finds from Basing House". Post-Medieval Archaeology 5. 63-70.

Mynard, D (1976) "Excavations on Mayorhold, Northampton, 1971". Northamptonshire Archaeology 11. 134-150.

Oswald, A, Philips, H (1949) "A Restoration Glass Hoard from Gracechurch Street, London". The Connoisseur September 1949. 30-36.

Platt, C (1973) Medieval Southampton, The Port and Trading Community, A.D. 1000-1600. Routledge & Kegan Paul, London.

Platt, C, Coleman-Smith, R (1975) Excavations in Medieval Southampton, vols. I&II. Leicester University Press, Leicester.

Revel, R (1989) "The Uses of Civility" in Aries ed. A History of Private Life, vol.III. Harvard University Press. 167-206.

Roberts, E & Parker, K (1992) Southampton Probate Inventories 1447-1575 Southampton Records Series XXXIV.

Ruddock, A (1951) Italian Merchants and Shipping in Southampton. 1270-1600. Southampton Records Series 1.

Salter, H (1960) Survey of Oxford vol.I. Oxford Historical Society new series xiv.

Salter, H (1969) Survey of Oxford vol.II. Oxford Historical Society new series xx.

Searle, J (1983) Intentionality: an essay in the Philosophy of Mind. Cambridge University Press, Cambridge.

Searle, J (1995) The Construction of Social Reality. Penguin Press, Allen Lane.

Tait, H (1967) "Glass with Chequered Spiral Trail Decoration". Journal of Glass Studies 9. 94-112.

Tait, H (1979) The Golden Age of Venetian Glass. British Museum Press, London.

Tait, H ed. (1991) Five Thousand Years of Glass. British Museum Press, London.

Thorpe, W (1961) English Glass. 3rd ed. Adam & Black, London.

Toulmin-Smith, L ed. (1906) The Itinerary of John Leland, in or about the years 1535-1543.

Vince, B, Bell, R (1992) "Sixteenth Century Pottery from Acton Court, Avon in Gaimster & Redknap eds. Everyday and Exotic Pottery from Europe, Studies in Honour of John G. Hurst. Oxbow Books.

Williams, F (1979) "Excavations on Marefair, Northampton, 1977". Northamptonshire Archaeology 14. 38-79.

Williams, J (1979) St. Peter's Street Northampton, Excavations 1973-76. Northampton Development Corporation, Northampton.

Winbolt, S (1933) Wealden Glass. Combridges, Hove.

Yentsch, A (1991) "Chesapeake Artifacts and their Cultural Context: Pottery and the Food Domain". Post Medieval Archaeology 6. 25-72.

Other Important References;

Allen, J (1984) "Medieval and Post Medieval Finds from Exeter, 1971-1980" Exeter Archaeological Reports 3.

Bickerton, L (1984) English Drinking Glasses, 1675-1825. Shire Publications.

Blair, J, Ramsay, N (1991) English medieval Industries; Craftsmen, Techniques and Products. Hambledon Press, London.

Charleston, R (1977-80) "Glass in the British Isles, Section V. Glass of the High Medieval Period". in Bull de L'Association Internationale pour L'Histoire du Verre 8. 65-76

Charleston, R, Evans, W, Werner, A eds. (1970) Studies in Glass History and Design. Unwin Brothers, Old Woking.

Coleman, D (1975) Industry in Tudor and Stuart England. Macmillan Press, London.

Conner, R (1987) The Weights and Measures of England. HMSO, London.

Crossley, D (1972) "A Sixteenth Century Wealden Blast Furnace; a report on excavations at Panningridge, Sussex 1964-70". Post Medieval Archaeology 6. 42-68.

Cunliffe, B (1964) Winchester Excavations, 1949-60 vol.1. City of Winchester Museums and Libraries Committee.

Douglas, M (1984) Food in the Social Order, Studies of Food and Festivities in Three American Communities. Russel Sage Foundation, New York.

Elville, E (1951) English Table Glass Country Life, London.

Harden, D (1971) "Ancient Glass III; Post Roman". Archaeological Journal 128. 78-117

Hawthorne, J, Stanley-Smith, C eds. (1963) Theophilus on Divers Arts. Dover Publications, New York.

Honey, W (1944) English Glass. Collins, London.

Klein, D, Lloyd, W (1992) The History of Glass. Little, Brown & Company, London.

Klesse, B Mayer, H (1987) European Glass from 1500-1800, The Ernesto Wolfe Collection. Kremayer 7 Scheriau, Vienna.

Margeson, S (1993) "Norwich Households; The Medieval and Post Medieval Finds from Norwich Survey Excavations, 1971-78". East Anglian Archaeological Report 58.

Salzman, L (1923) English Industries of the Middle Ages. Clarendon Press, Oxford.

Wilmer, D (1910) Early English Glass.

Wilson-Frothingham, A (1963) Spanish Glass Faber & Faber, London.

