



Durham E-Theses

Electrophilic fluorination methodology

Thomas, Emmanuelle Maitrise de Chimie

How to cite:

Thomas, Emmanuelle Maitrise de Chimie (2002) *Electrophilic fluorination methodology*, Durham theses, Durham University. Available at Durham E-Theses Online: <http://etheses.dur.ac.uk/4151/>

Use policy

The full-text may be used and/or reproduced, and given to third parties in any format or medium, without prior permission or charge, for personal research or study, educational, or not-for-profit purposes provided that:

- a full bibliographic reference is made to the original source
- a [link](#) is made to the metadata record in Durham E-Theses
- the full-text is not changed in any way

The full-text must not be sold in any format or medium without the formal permission of the copyright holders.

Please consult the [full Durham E-Theses policy](#) for further details.

University of Durham

A Thesis Entitled

Electrophilic Fluorination Methodology

Submitted by

Emmanuelle Thomas Maitrise de Chimie (Hons.)
(Graduate Society)



14 APR 2003

A Candidate for the degree of Doctor of Philosophy

Department of Chemistry

2002

The copyright of this thesis rests with the author.
No quotation from it should be published without
his prior written consent and information derived
from it should be acknowledged.

For Mum, Dad and Kristian

Acknowledgements

I would like to thank my supervisors Professor R. D. Chambers and Dr G. Sandford for their precious help and advice throughout the last three years.

I would also like to thank the European Union TMR funding, EPSRC.

My thesis could have not been completed without the huge help of Dr Alan Kenwright, Catherine Hefferman and Ian McKeag (NMR). As well as Dr Mike Jones and Miss Lara Turner (mass spectroscopy). And thank to all the technical staff working at the University of Durham.

Memorandum

The work described in this thesis was carried out at the University of Durham between the 1st October 1999 and 30th September 2002. This thesis is the work of the author, except where acknowledged by reference, and has not been submitted for any other degree.

This work has been presented by the author, in part, at:

- **13th European Fluorine Symposium**, 15-20 July, Bordeaux, France.
Poster presentation "**Electrophilic Fluorination of Hydrocarbon Systems**"
- **First Fluorine Postgraduate Meeting organised by The RSC**, 5th of September 2001, Leicester, UK. Poster as above.
- **Perkin North East Division**, 8th of April 2002, York, UK. Poster as above.

And in paper form in:

- R. D. Chambers, E. Thomas, M. Parsons, G. Sandford, **Selective Fluorination of Functionalised Hydrocarbons**, *J. C. S. Perkin Trans 1*, in preparation.
- R. D. Chambers, E. Thomas, J. Trmcic, G. Sandford, **Fluorofunctionalisation of Ethers**, *J. C. S. Perkin Trans 1*, in preparation.

Nomenclature and Abbreviations

The following abbreviations have been used.

NMR Nuclear Magnetic Resonance

GC-MS	Gas Liquid Chromatography-Mass Spectroscopy
IR	Infra Red Spectroscopy
MeCN	Acetonitrile

Statement of Copyright

The copyright of this thesis rests with the author. No quotation from it should be published without their prior written consent and information derived from it should be acknowledged.

Abstract

Electrophilic Fluorination Methodology

Emmanuelle Thomas, University of Durham, 2002.

Chapter One

This chapter reviews the historical background of the fluorination using both elemental fluorine and N-F reagents. It relates the properties and preparations of these electrophilic reagents. And finally it discusses the use of these reagents in selective electrophilic fluorination (formation of C-F bond from C-H bond) of organic compounds.

Chapter Two, Three and Four

These chapters present our investigations into the fluorination of hydrocarbon systems containing an electron withdrawing group (ewg).

Chapter Two shows the difference in reactivity of elemental fluorine and Selectfluor™ towards aldehydes and ketones. Selectfluor gives rise to α -fluorinated compound when reacting with ketones (acyclic and cyclic ones) whereas different results were observed using fluorine.

In Chapter Three aldehydes are submitted to fluorination which occurred at the carbonyl and not on the chain.

Finally, Chapter Four review the fluorination of nitriles using both fluorinating reagents.

Chapter Five

In this last Chapter we explore the fluorination of cyclic ethers (hydrocarbon systems containing an electron donating group) using both elemental fluorine and Selectfluor™. Unexpected derivatives were identified.

Chapter Six to Nine

Experimental details relating to Chapter Two-Five.

Contents

<u>Chapter One.</u>	Introduction	1
1.1.	Fluorine in Chemistry	1
1.2.	Physical Properties of Elemental Fluorine	3
1.3.	History of Elemental Fluorine	5
1.4.	Preparation of Elemental Fluorine	6
	1.4.a. Electrochemical Generation of F ₂	6
	1.4.b. Chemical Synthesis of Elemental Fluorine	6
1.5.	Mechanistic Considerations of Fluorination	7
	1.5.a. Radical Fluorinations	7
	1.5.b. Perfluorination of Organic Compounds	10
	1.5.c. Electrophilic Process	11
	1.5.c.i. Fluorination of Alkenes	11
	1.5.c.ii. Fluorination of Saturated Sites	12
	1.5.c.iii. Fluorination of Aromatics	15
	1.5.c.iv. Fluorination of Carbonyl Compounds	22
1.6.	Fluorination using Selectfluor™ (F-TEDA-BF ₄)	26
	1.6.a. Historical Background of the N-F Reagents	26
	1.6.b. Properties of F-TEDA-BF ₄	28
	1.6.c. Synthesis of F-TEDA Reagents and their 'F ⁺ ' Delivery Potential	29
	1.6.d. Applications of F-TEDA-BF ₄ in C-F Bond Synthesis	32
	1.6.d.i. Electrophilic Fluorination of Aromatics	32
	1.6.d.ii. α-Fluorination of Sulphides	34
	1.6.d.iii. Synthesis of α-Fluoro Carbonyl Compounds	36

	1).	Via β -Dicarbonyl Compounds	36
	2).	Via Enol Ethers, Enamines and Imines	37
	3).	Via Fluorination of Alkynes	38
	1.6.d.iii.	Fluorination at Saturated Sites	38
	1.6.e.	Mechanistic studies	39
1.7.		Conclusion	42
<u>Chapter Two.</u>		Fluorination of Ketones	43
2.1.		Introduction	43
2.2.		Fluorination of Ketones using Selectfluor™	43
	2.2.a.	Acyclic Ketones	43
		2.2.a.i. 2-Heptanone	43
		2.2.a.ii. 2-Octanone	44
		2.2.a.iii. 2,5-Hexanedione	46
	2.2.b.	Cyclic Ketones	47
		2.2.b.i. Cyclopentanone	47
		2.2.b.ii. Cyclohexanone	48
		2.2.b.iii. Cycloheptanone	48
	2.2.c.	Mechanism	49
2.3		Fluorination of Ketones using Fluorine	51
	2.3.a.	Acyclic Ketones	51
		2.3.a.i. 2-Heptanone	51
		1). AlCl_3	52
		2). Triflic Acid	53
		3). Selectfluor™	55
		4). $\text{BF}_3 \cdot \text{Et}_2\text{O}$	55
		5). Copper Nitrate	57
		6). Cerium Ammonium Nitrate (CAN)	57

2.3.a.ii.	2,5-Hexanedione	59
2.3.b.	Cyclic Ketones	60
2.3.b.i.	Cyclopentanone	60
2.3.b.ii.	Cyclohexanone	61
2.3.b.iii.	Cycloheptanone	62
2.3.c.	Mechanism	63
2.4.	Conclusion	64
<u>Chapter Three.</u>	Fluorination of Aldehydes	65
3.1.	Introduction	65
3.2.	Fluorination of Heptanal using Fluorine	65
3.3.	Mechanism	66
3.3.a.	Fluorination	66
3.3.b.	Nucleophilic Displacement	67
3.4.	Fluorination of Heptanal using Selectfluor™	68
3.5.	Fluorination of Decanal	68
3.6.	Fluorination of Benzaldehyde	70
3.7.	Fluorination of Trifluoromethyl- <i>para</i> -Tolualdehyde	71
3.8.	Fluorination of <i>para</i> -Tolualdehyde	74
3.9.	Mechanism	74
3.9.a.	Fluorination	74
3.9.b.	Nucleophilic Displacement	76

3.10.	Conclusion	76
<u>Chapter Four.</u>	Fluorination of Nitriles	78
4.1.	Introduction	78
4.2.	Fluorination of Nitriles using Selectfluor™	78
4.2.a.	Fluorination of Heptanenitrile	78
4.2.b.	1,5-Dicyanopentane	80
4.3.	Fluorination of Nitriles using Elemental Fluorine	81
4.3.a.	Octanenitrile	81
4.3.b.	Heptanenitrile	82
4.3.c.	Other Systems	83
4.4.	Conclusion	83
<u>Chapter Five.</u>	Fluorination of Ethers	84
5.1.	Introduction	84
5.2.	Fluorination of Ethers using Selectfluor™	84
5.2.a.	Tetrahydrofuran	84
5.2.a.i.	Mechanism of Formation	86
5.2.b.	Tetrahydropyran	88
5.2.c.	1,4-Dioxane	90
5.2.c.i.	Mechanism of Formation	91
5.2.d.	Hexamethylene Oxide	94
5.2.d.i.	Mechanism of Formation	95
5.2.e.	Other Systems	97
5.3.	Fluorination of Ethers using Elemental Fluorine	97
5.3.a.	Tetrahydrofuran	97

5.3.a.i.	Mechanism of Formation	98
5.3.b.	Tetrahydropyran	101
5.3.c.	1,4-Dioxane	101
5.3.d.	Hexamethylene Oxide	102
5.3.e.	Other Systems	103
5.3.Conclusion		104
General conclusion		105
<u>Experimental Part</u>		106
The Use of Fluorine in the Laboratory		106
Instrumentation and Reagents		107
<u>Chapter Six.</u>	Experimental to Chapter Two	109
<u>Chapter Seven.</u>	Experimental to Chapter Three	117
<u>Chapter Eight.</u>	Experimental to Chapter Four	121
<u>Chapter Nine.</u>	Experimental to Chapter Five	124
<u>Appendices</u>		
Appendix One	Nuclear Magnetic Resonance Spectra	129
Appendix Two	Crystal Data of (37)	157
<u>References</u>		161

Chapter One: Introduction

1.1. Fluorine in Chemistry^{1,2}

Molecules containing some carbon-fluorine bonds do not occur in nature apart from a few exceptions although fluorite (CaF_2) and fluoroapatite ($\text{CaF}_2 \cdot 3\text{Ca}_3(\text{PO}_4)_2$) are both widely present in the earth's crust. This means that organofluorine chemistry is a 'man-made' field.

It is only in the last 60 years that the difficulties associated with the production of fluorine have been satisfactorily overcome. As a result, elemental fluorine has now become established as an industrial chemical. The manufacture of fluorinated inorganic and organic compounds has given an impetus to fluorine chemistry. Inorganic fluorine compounds are used for a wide range of applications. Typical areas of application include metallurgy, aluminium production by electrolysis, ceramics, nuclear technology, the preservation of timber and adhesives, etc...

In the field of organofluorine chemistry the development of new methods of synthesis and new products continues. Fluorine-containing polymers are an important group of organic fluorine products, highly valued for their many remarkable properties. The most well known examples are polytetrafluoroethylene (PTFE) and polyvinylidene fluoride (PVDF). Organofluorine compounds have also a great biological activity and can be used for biomedical applications. Some of these compounds have greater lipophilicity, facilitate passage across cell membranes and have application in the pharmaceutical and agrochemical industries^{3,4}.

Fluorinated organic compounds are also used as:

- starting materials for organic synthesis
- solvents
- surfactants
- special-purpose dyes
- pharmaceuticals and anaesthetics
- pesticides
- insecticides
- blood substitutes

Examples of known commercial fluorinated products⁵

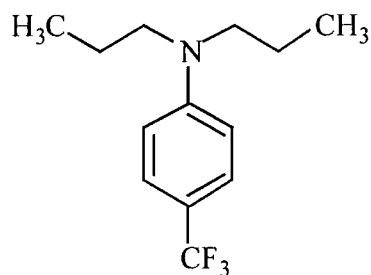

Trifluralin
(herbicide)

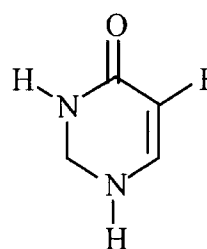

5-Fluorouracil (5-FU)
(anti-cancer agent)

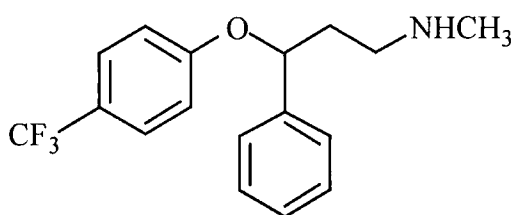

Fluoxetine
(anti-depressant)

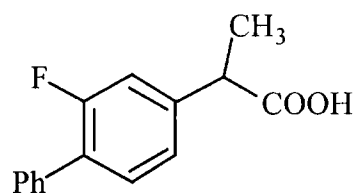

Froben
(anti-inflammatory)

Scheme 2.1

Dramatic changes in the physical and biological properties as well as chemical reactivities of organic materials can be brought about by fluorination. Three primary factors have led to the distinction acquired by fluorine as a substituent in organic molecules:

- the great strength of the C-F bond (strongest single bond to carbon).
- the small size of fluorine (smallest substituent after hydrogen).
- Fluorine (element 9) is the most electronegative chemical element.

1.2. Physical Properties of Elemental Fluorine

At room temperature, fluorine is a pale green diatomic gas. Fluorine is found as a single isotope ^{19}F in nature but ^{18}F is known (half-time=109.7 min) and can be used as a tracer. Most of the physical properties of the halogens are summarised in Table 1⁶.

Property	Fluorine	Chlorine	Bromine	Iodine
Density of solid g/cm^3	1.3	1.9	3.4	4.9
Melting point $^{\circ}\text{C}$	-223	-102	-7.3	114
Boiling point $^{\circ}\text{C}$	-187	-34.7	58.8	183
Heat of Vapourisation kJ/mol	6.9	18.6	31.2	43.6
Heat of Dissociation kJ/mol	158.3	239.0	189.8	148.7
Covalent Radius \AA	0.72	0.99	1.14	1.33
Ionisation Potential eV	17.42	13.01	11.84	10.44
Electron Affinity eV	4.13	3.75	3.53	3.2
Electronegativity	4.0	3.0	2.8	2.5

Table 1.1

Fluorine is chemically the most reactive element and can combine directly at room or elevated temperatures with all the other elements except the lighter noble gases and nitrogen. It reacts in particular with organic compounds because of the very

favourable formation of a C-F bond coupled with the low dissociation energy of elemental fluorine (Table 1.2)⁷.

Bond	Bond Energy kJ / mol
CF ₄	487
-CF ₃	478
-CF ₂	458
-CF	449
H-F	562
-N-F	272
-P-F	490

Table 1.2

Fluorine reacts with hydrogen with extreme violence to produce HF while it produces oxygen, oxygen fluoride and sometimes, small quantities of ozone and hydrogen peroxide when it reacts with water. Fluorine can combine with other halogens in a highly exothermic reaction from which a series of interhalogen compounds are formed, e.g. FCl, ClF₃, BrF₃. It attacks metals at room temperature but some metals, e.g. copper and nickel, form a protective layer of fluoride which prevents further reaction. This is termed passivation and is invaluable in the handling of elemental fluorine.

The success of organofluorine chemistry in such a wide variety of applications 'opens' a very bright future of the subject. Our group is working on the fluorination of organic compounds promoting the use of elemental fluorine. Our aim was the direct synthesis of C-F bonds from C-H in hydrocarbon systems containing a functional group. The results of this study are presented in Chapters Two-Five. What follows is an overview of the historical background and use of elemental fluorine in organic chemistry.

1.3. History of Elemental Fluorine

Fluorine gas was first isolated in 1886 by Henri Moissan⁸ by electrolysis of anhydrous hydrogen fluoride. Moissan observed that the reaction of fluorine with a range of organic compounds such as CH₄, CHCl₃ and CCl₄ resulted in 'burning' of the substrate with frequent explosions⁹. In 1890, he claimed to have isolated CF₄ from reaction of carbon with fluorine. But these results were later to be shown in error by Swarts¹⁰.

The fluorine-ignition problem could be controlled by Bockmüller in 1933¹¹. He was the first to demonstrate selective liquid phase fluorination by dissolving an organic compound in an inert solvent and then bubbling a mixture of fluorine and an inert gas, e.g. nitrogen or carbon dioxide through the solution. Using this method, *n*-butyric acid was fluorinated. He also observed that direct fluorination could show site selectivity.

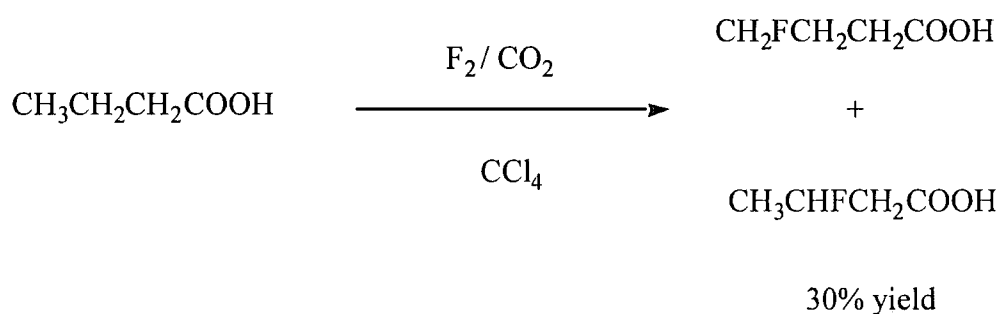

Scheme 1.2

Similar work was carried out by Bigelow^{12, 13} dealing with liquid phase fluorination of aromatics dissolved or suspended in cold CCl₄. No synthetically useful results were observed but confirmed Bockmüller's results.

Another method for controlling direct fluorination was to react fluorine gas with organic vapours in meshes of copper. This vapour phase fluorination approach was developed by Fredenhagen and Cadenbach¹⁴. Bigelow achieved further success by dilution of elemental fluorine with nitrogen¹⁵. Following this approach, he demonstrated the fluorination of hydrocarbons to produce fluorocarbons.

Solid phase fluorination was explored. Fluorine was passed over a mixture of the solid substrate and an inert diluent (e.g nickel). The most significant reaction was the fluorination of carbon itself using mercuric chloride as a catalyst reported by Simons¹⁶. These fluorocarbons prepared by Bigelow and Simons exhibited high chemical and thermal stability including resistance to UF₆ leading to their use in the Manhattan project of World War II. This generated great interest in fluorinated organic compounds. Fluorine chemistry was about to begin.

1.4.Preparation of Elemental Fluorine

1.4.a. Electrochemical Generation of F₂¹⁷

Fluorine is indirectly prepared from fluorspar (CaF₂). It is heated with sulfuric acid and the resulting mixture is distilled to give high purity anhydrous hydrogen fluoride. Hydrogen fluoride is then combined with potassium fluoride and the mixture is electrolysed to give elemental fluorine at the anode. This approach has been extended and is used extensively in the large scale commercial preparation of fluorine, most commonly using a mixture of KF.2HF (mp 71.7°C) with the cell heated to around 100°C. Corrosion of reactors is reduced through the use of metals like copper and nickel which soon develop a protective coating.

1.4.b. Chemical synthesis of elemental fluorine

The first real chemical synthesis of fluorine was carried out by Steel¹⁸ in 1959 (scheme 1.3).

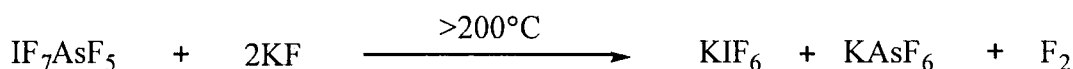

Scheme 1.3

The first practical chemical synthesis of fluorine was demonstrated by Christie¹⁹ (scheme 1.4).

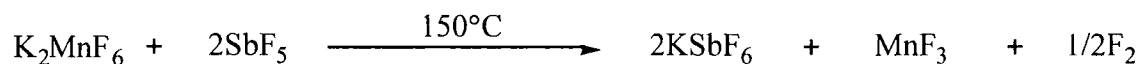

Scheme 1.4

The synthesis is based on two facts:

- a) Formation of unstable high oxidation transition state metal fluorides which can be stabilised by anion formation, e.g. MnF_4 and NiF_4 are stabilised as MnF_6^{2-} .
- b) Weak Lewis acids such as MnF_4 can be displaced by a stronger one, e.g. SbF_5 .

1.5.Mechanistic Considerations of Fluorination

There are two pathways of attack between fluorine and organic molecules depending on the homolytic or heterolytic fission of the F-F bond. Radical reactions are generally fast but usually unselective and uncontrolled whereas electrophilic processes are slower, more controlled and directed by charge interactions. The balance between these processes determines the degree of selectivity and control in these reactions. Promoting the electrophilic process increases control and selectivity of fluorinations.

1.5.a Radical Fluorinations

Reactions between hydrocarbons and elemental fluorine are extremely exothermic because of the high heats of formation of bonds from fluorine to carbon and hydrogen. This, coupled with the low dissociation energy of fluorine suggests that the most likely pathway of fluorination is a radical process (scheme 1.5).

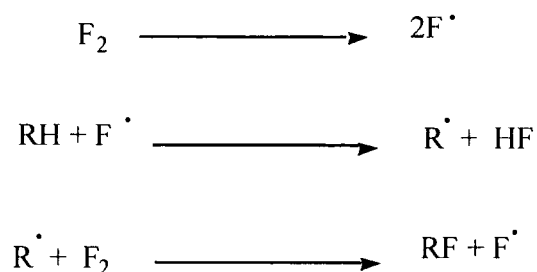

Scheme 1.5

Radical processes are normally initiated by the dissociation (thermal or photochemical) of a molecule with a weak bond. However, fluorine is not significantly dissociated at room temperature. An alternative mechanism (scheme 1.6) has been suggested by Miller involving the reaction of fluorine with hydrocarbon molecule to generate radical²⁰⁻²².

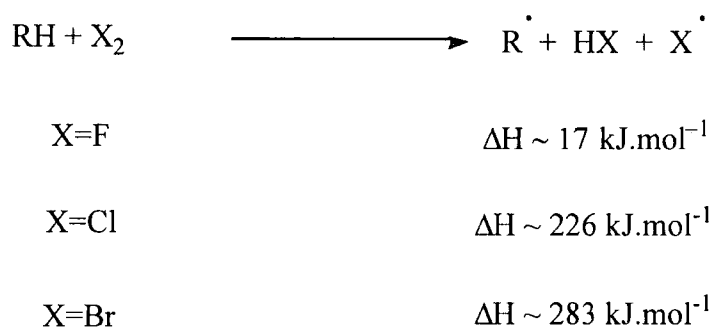

Scheme 1.6

Experimental evidence for the above initiation process is difficult to obtain. The radical fluorination of alkenes would seem to support this theory (exothermic process generating two radical intermediates) (scheme 1.7).

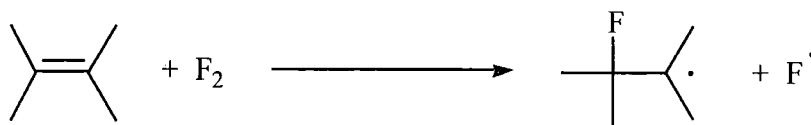

$$\Delta H \sim -4.8 \text{ kJ}\cdot\text{mol}^{-1}$$

Scheme 1.7

Radical fluorinations are less selective than chlorinations²³. The relative rates of substitution by fluorine of the primary, secondary and tertiary sites in hydrogens in *n*-butane and *iso*-butane were compared with chlorination (Table 1.3).

Radical	-CH ₃	-CH ₂	-CH
F [•]	1	1.3	2.5
Cl [•]	1	4.6	10.3

Table 1.3 Relative rates of substitution of hydrocarbons by fluorine and chlorine at 300K

The lack of selectivity does not fit with Bockmüller's results with butyric acid (seen previously p.5 scheme 1.2). It was found that fluorination is more affected by substitution or polar effects than chlorination or bromination, suggesting an electrophilic mode of attack.

1.5.b. Perfluorination of organic compounds²⁴

Perfluorinated compounds are ideal for handling elemental fluorine because of their stability and chemical resistance. Three perfluorination synthetic procedures have been widely used. Two of these processes, electrochemical fluorination (ECF), successfully used for the preparation of perfluoroacids, and fluorination by high valent metal fluorides (CoF_3), are used for the preparation of perfluorocarbons. The third major process for the preparation of perfluorinated compounds involves direct fluorination.

Attempts to moderate the high reactivity of fluorine towards organic substrates led to the development of the vapour phase 'Jet fluorination' apparatus and a catalytic metal-packing process. Both used elemental fluorine diluted with an inert gas such as nitrogen or helium.

The introduction of the low temperature gradient (LaMar process) in 1970 gave a real impetus to the study of direct perfluorination of organic substrates.

Lagow has shown that perfluorinated products of hydrocarbons can be obtained using elemental fluorine. His first published example was the perfluorination of polyethylene oxide^{25, 26}.

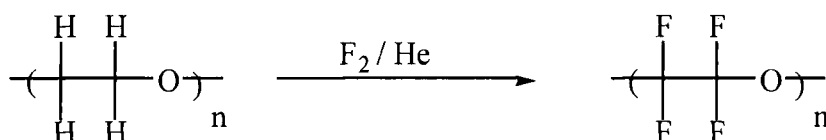

Scheme 1.8

He was able to control this process using low temperature and high dilution. The high solubility of fluorine in fluorocarbons solved the problem of removing the last hydrogens from the substrate using heating. Over many years the Lagow perfluorination process has been extended to produce many new classes of organic compounds including perfluoroadamantane (**1**)^{27, 28}, perfluorocrown ethers (**2**)^{29, 30} and perfluoro *ortho*-carbonates (**3**)³¹.

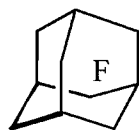

(1)

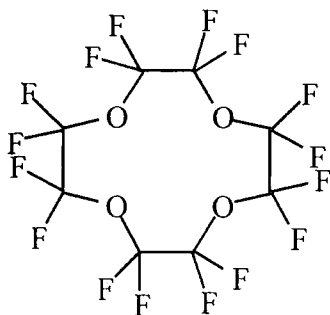

(2)

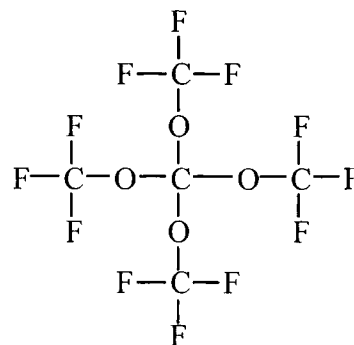

(3)

1.5.c. Electrophilic Process

This thesis is an investigation of selective electrophilic fluorination. Chapters Two-Five detail the fluorination of both hydrocarbon systems bearing an electron withdrawing and electron donating group.

1.5.c.i. Fluorination of Alkenes

Merritt recognized in the 1960's³²⁻³⁵ the electrophilic nature of fluorine during investigations concerning the addition of fluorine to alkenes. The reaction was carried out using one equivalent of fluorine at low temperature and pressure and resulted in products showing that a *syn* mode of addition predominated. He ruled out a free radical pathway based on the observed selectivity and the reaction conditions and proposed a concerted pathway. However, a mechanism that proceeds by way of a tight ion pair for the addition of acetyl hypofluorite to alkenes is more reasonable. The mechanism is shown below (scheme 1.9):

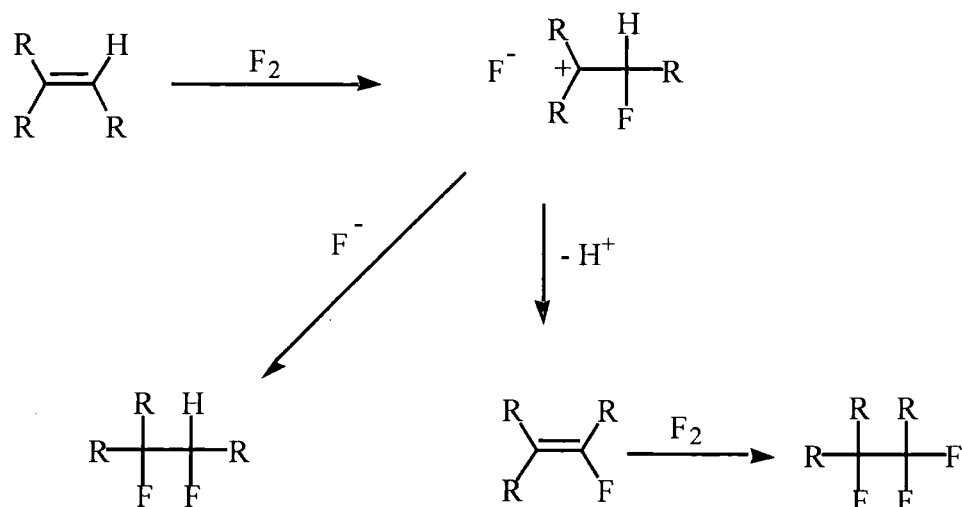

Scheme 1.9

The unstable α - fluoro carbocation gives rise to the vinyl fluoride by loss of a proton or adds fluoride to give the vicinal difluoride. The vinyl fluoride is the precursor to the trifluorinated products.

1.5.c.ii. Fluorination at Saturated Sites

The difference between radical and electrophilic fluorination processes is the degree of selectivity and control of the reaction. Radical fluorinations are fast, unselective and uncontrolled whereas electrophilic processes are slower and more controlled. Therefore, promoting an electrophilic mode of attack improves control and selectivity of fluorinations. The reactions proceed via a non classical 3 centre-2 electron transition-state with a retention of configuration by a S_E2 process²⁴. The reaction is not operable in nonpolar solvents (eg CFCl_3 , hexane) because a radical reaction occurs. A polar solvent promotes the polarisation of F-F bond and acts as an acceptor for the fluoride ion produced²⁴. The mechanism is as follows (scheme 1.10).

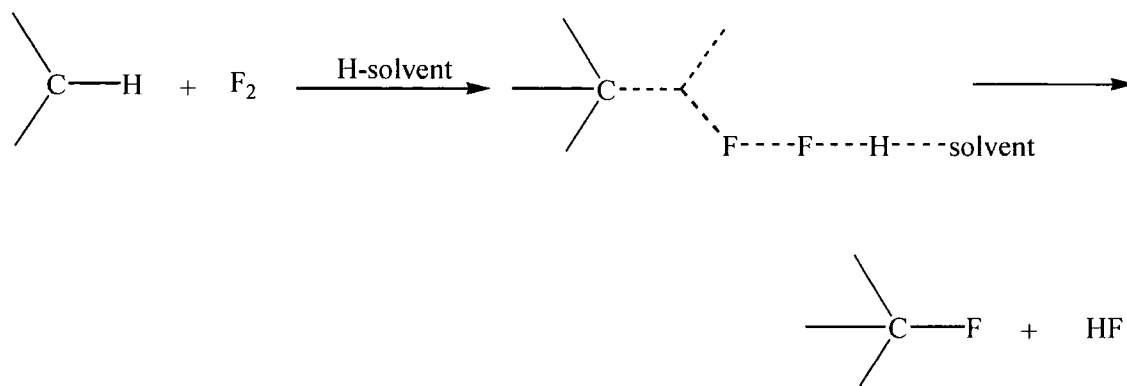

Scheme 1.10

Rozen³⁶⁻⁴¹ demonstrated that elemental fluorine can be used to replace selectively saturated C-H by C-F bonds in a range of organic molecules. Using the protected 4-methylcyclohexanol (scheme 1.11) Rozen established that a polar reaction medium is essential for selective fluorination. When the same reaction was carried out in a 1:1 mixture of CFCl_3 and CHCl_3 , the substitution of the tertiary hydrogen at C-4 by fluorine with retention of configuration was observed in 60% and 83% yield⁴².

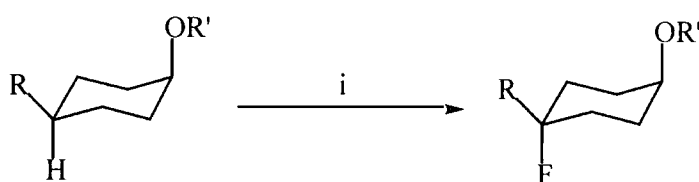

R=Me, R'=p-COC₆H₄NO₂, 60% yield

R=tBu, R'=p-COC₆H₄NO₂, 83% yield

i = F_2/N_2 , -78°C , CFCl_3 , CHCl_3

Scheme 1.11

In unstrained molecules the electron density at a tertiary hydrogen is greater than that at secondary or primary sites so the hydrogen is more vulnerable to substitution. Purrington demonstrated a substitution with retention of configuration. Few examples are presented

below⁴³.

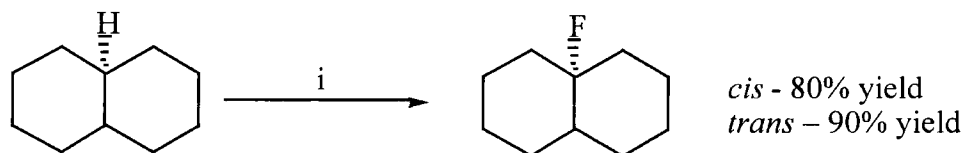

$i=1\% \text{ F}_2/\text{N}_2, \text{CHCl}_3/\text{CFCl}_3, -78^\circ\text{C}$

Scheme 1.12

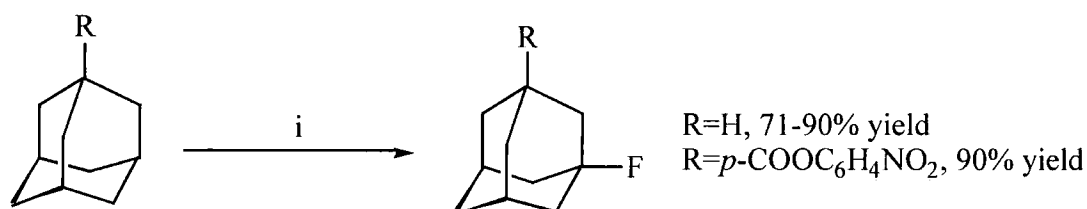

$i=10\text{-}20\% \text{ F}_2/\text{N}_2, \text{CFCl}_3, -78^\circ\text{C}$

Scheme 1.13

Because of the limitation of the reaction conditions seen previously, Chambers and co-workers⁴⁴ have investigated other systems. Reactions were carried out in acetonitrile at 0°C . Using these conditions the fluorination of secondary and tertiary C-H bonds was successfully performed. A few examples are presented below.

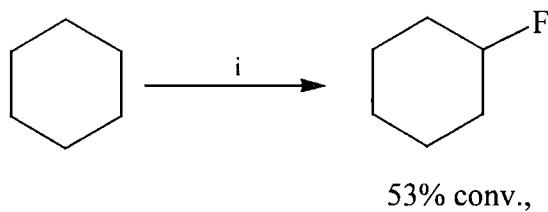

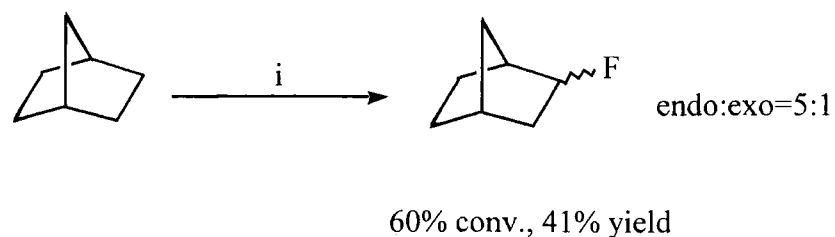

$i=10\% \text{ F}_2/\text{N}_2, \text{CHCl}_3, 0^\circ\text{C}.$

Scheme 1.14

1.5.c.iii. Fluorination of Aromatics

The fluorination of aromatic rings was attempted but presented problems. In 1970, Grakauskas fluorinated a 6% solution of benzene (scheme 1.15)⁴⁵ in acetonitrile at -35°C using $<0.76\%$ of F_2 in N_2 to give the following compounds. He postulated an electrophilic fluorination.

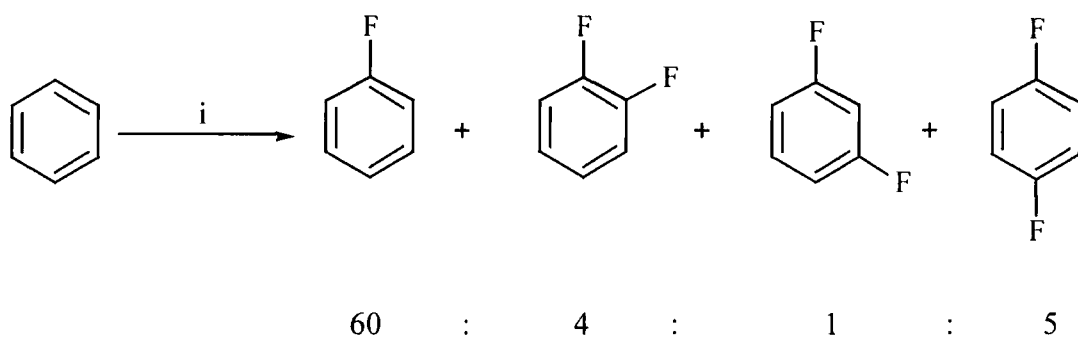

$i = \text{F}_2, \text{CH}_3\text{CN}, -35^\circ\text{C}$

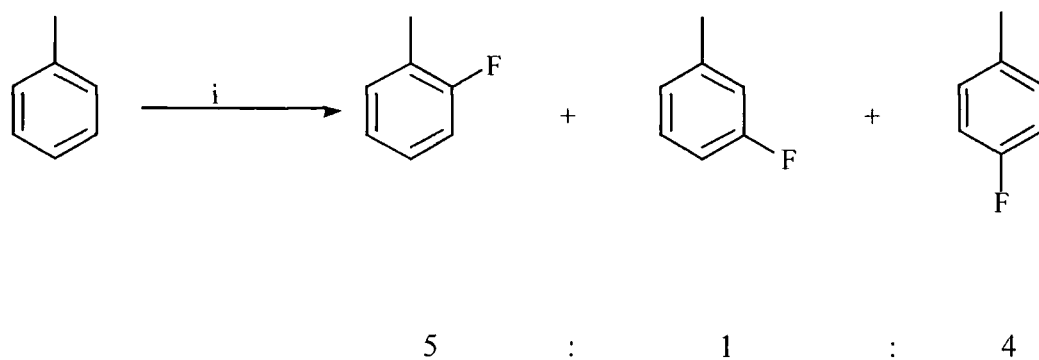

$i = F_2, CH_3CN, -70^\circ C$

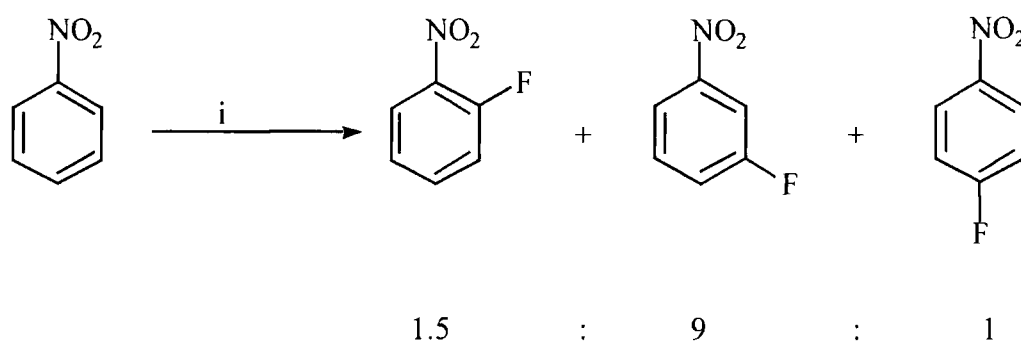

$i = F_2, CH_3CN, -15^\circ C$

Scheme 1.15

Toluene underwent electrophilic substitution predominantly in the *ortho/para* position and nitrobenzene predominantly in the *meta* position. Grakauskas proposed the following electrophilic substitution mechanism:

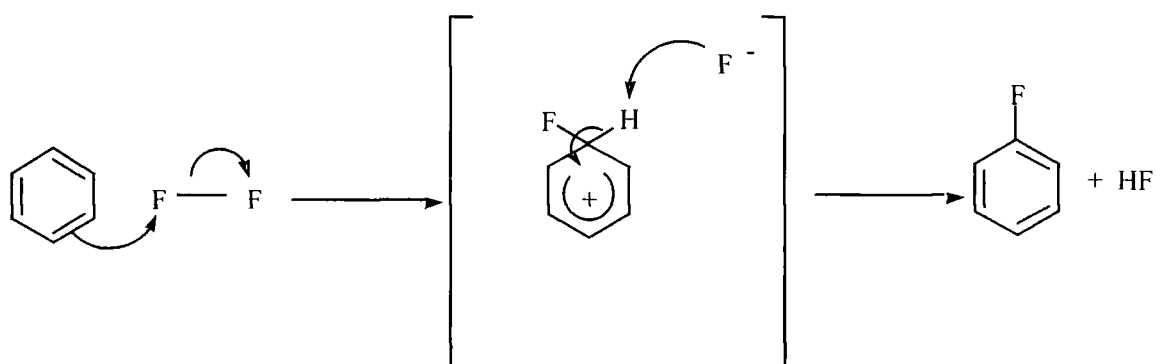

Scheme 1.16

Misaki has investigated the fluorination of various substituted phenols in acetonitrile ⁴⁶.

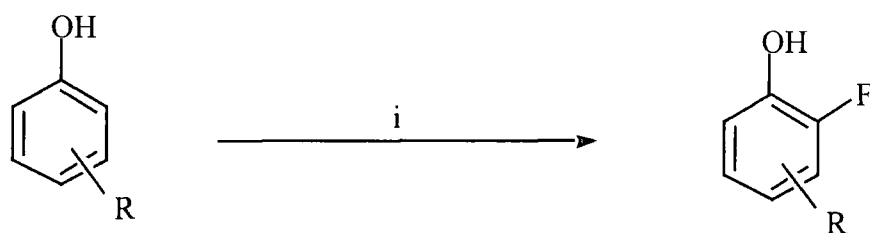

- a) R=2-methyl
- b) R=3-methyl
- c) R=2-COOH
- d) R=2-CHO

i = F₂, CH₃CN, -10 to -20°C

Scheme 1.17

The results are summarised in the following table:

R	T(°C)	% conversion	Products (%)
2-Me	-20	70.8	4-F (27.5) 6-F (22.5)
3-Me	-20	67.7	4-F (20.7) 6-F+2-F (46.4)
2-COOH	-10	79.0	4-F (55.9) 4, 6-F ₂ (21.0)
2-CHO	-10	62.9	4-F (32.1) 6-F (22.1)

Table 1.4

p-Cresol produces a very interesting side product in addition to the expected *o*-fluoro derivative. 4-Fluoro-4-methyl-2,5-cyclohexadienone was observed in yields as high as 42% in tetraglyme at -20°C.

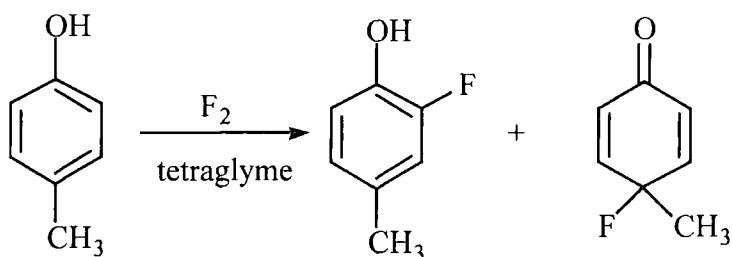

Scheme 1.18

The direct fluorination of aromatic compounds had been carried out in Durham by Chambers and co-workers. They suggested that fluorination could occur by both one and two electron transfer processes⁴⁷.

Path A : 1 electron transfer

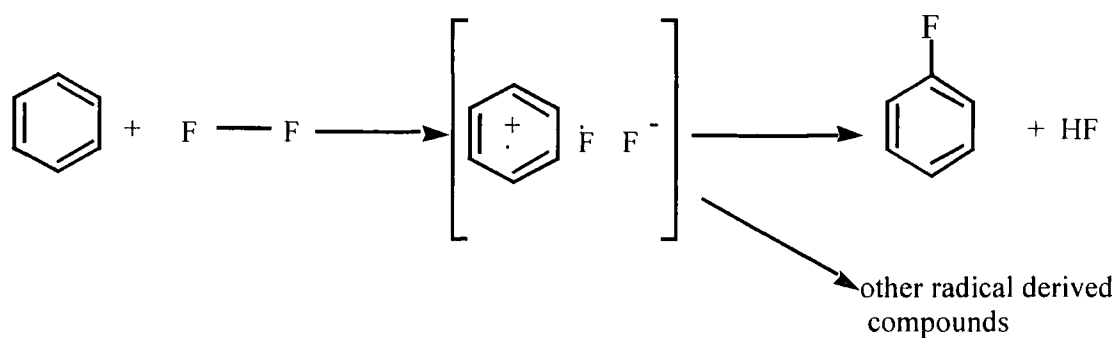

Path B : 2 electron transfer ($S_{E}Ar$ process)

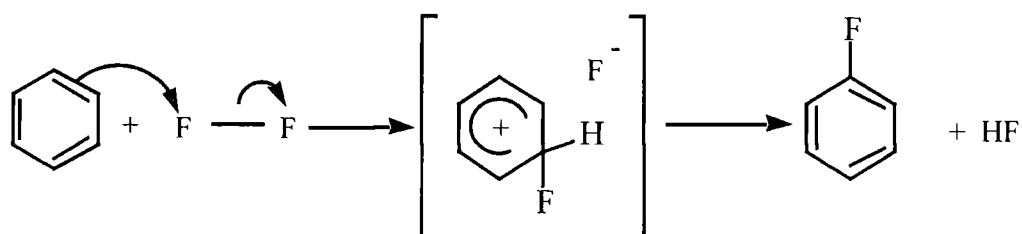

Scheme 1.19

The fluorination of activated aromatic compounds occurs mainly in the *ortho* and *para* positions whereas the fluorination of deactivated compounds takes place predominantly in the *meta* position. This is consistent with an electrophilic substitution process. The solubility of fluorine in the solvent has a major effect on the rate of the fluorination reactions. Polar and acidic solvent have been used to promote the electrophilic fluorination⁴⁸⁻⁵⁰. Using 4-fluorobenzoic acid as a model, the fluorination was studied using a range of solvents (Scheme 1.20).

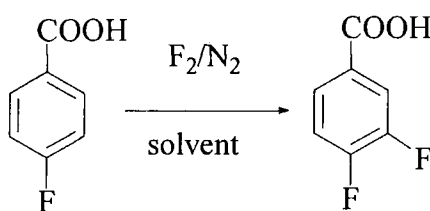

Solvent	Conversion (%)
CF ₂ ClCFCl ₂	0
CH ₃ CN	53
CF ₃ COOH	56
HCOOH	65
conc.H ₂ SO ₄	84

Scheme 1.20

This table showed that the conversion increased with the increasing acidity of the solvent used. The mechanism involved the interaction between fluorine and the solvent used. Recently, polar and acidic solvents have been used as reaction media to promote the electrophilic pathway (B) in which the interaction between fluorine and the acid is envisaged (scheme 1.21).

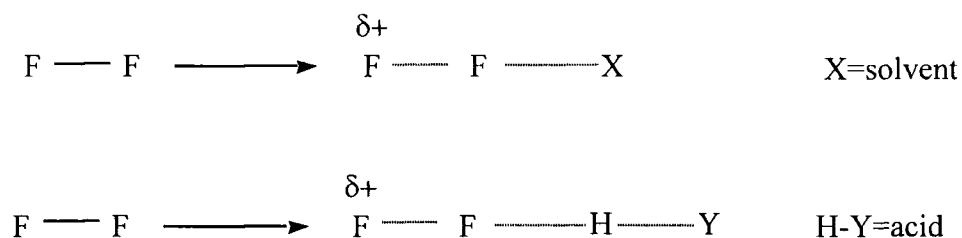

Scheme 1.21

Fluorine may act as a powerful electrophile in high acidic media. In this way, 2,4-difluorobenzoic acid, which is a very deactivated towards electrophilic attack, has been fluorinated in concentrated sulfuric acid. It gave 2,3,4,5-tetrafluoro and even some pentafluoro-benzoic acid.

When there are two or more groups in the substrate activating the same carbon towards electrophilic attack, the direct fluorination is an efficient method to prepare fluoroaromatic derivatives³⁷.

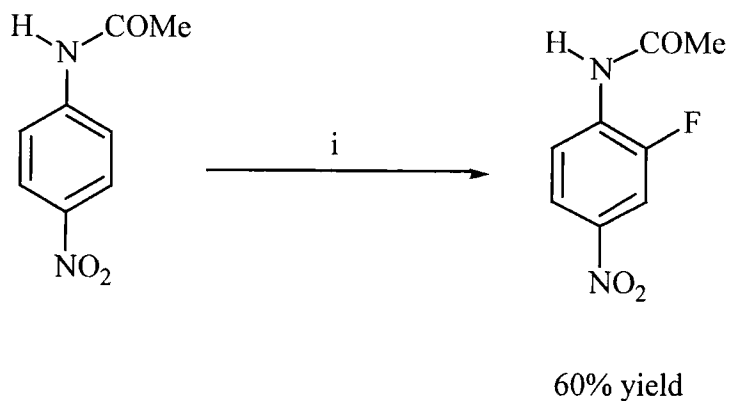

$i = F_2, HCOOH, 10^\circ C$

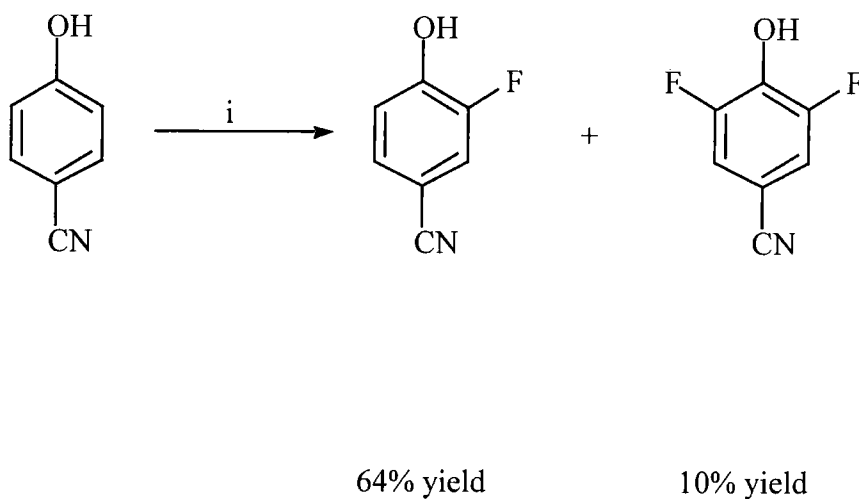

$i = F_2, HCOOH, 10^\circ C$

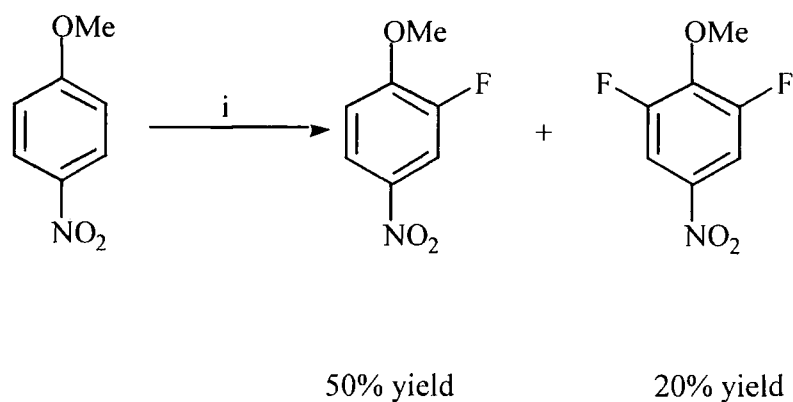

$i = F_2, HCOOH, 10^\circ C$

Scheme 1.22

1.5.c.iv. Fluorination of Carbonyl Compounds

In attempts to prepare α -fluorocarbonyl compounds, direct fluorination of enol derivatives of ketones and aldehydes were studied. For instance, some substituted pyruvate esters have been fluorinated in good yields using fluorine in nitrogen⁵¹.

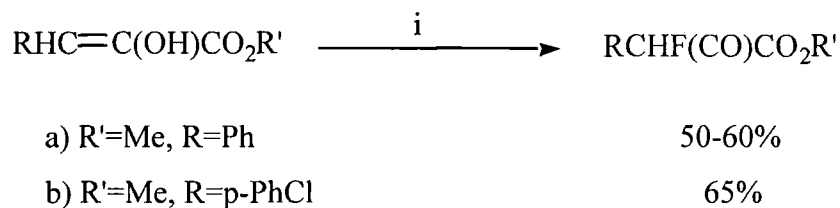

$i = F_2, CFCl_3, -78^\circ C$

Scheme 1.23

Purrington⁵² prepared some α -fluoroaldehydes and ketones using trimethylsilyl derivatives⁴⁷. All these reactions were carried out at -78°C , in CFCl_3 .

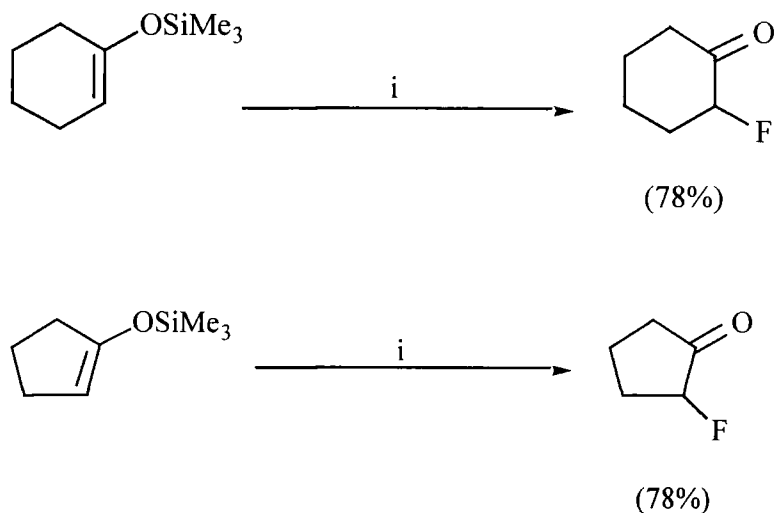

Scheme 1.24

The mechanism was suggested to proceed via a six membered transition state as so:

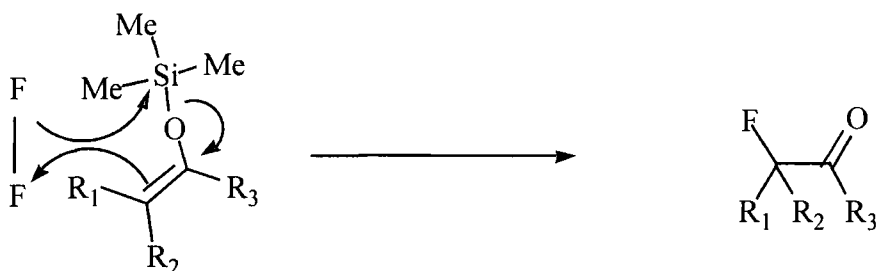

Concerning the direct fluorination of enol acetates, Rozen claimed it was not an effective way to produce α -fluorocarbonyl derivatives. These reactions were reported to give complicated mixtures and no definite isolatable products. The exception is the direct fluorination of vinyl acetate⁵³.

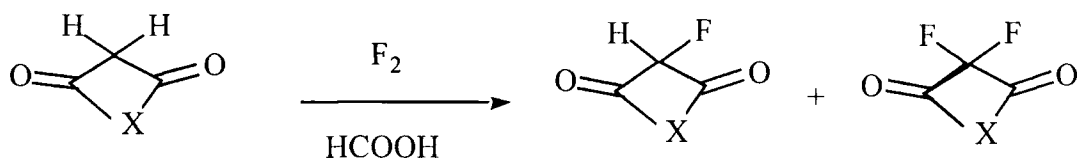

a) X=-CH ₂ CMe ₂ CH ₂ -	10%	50%
b) X=-NHCONH-	50%	30%

Scheme 1.28

It was concluded that the mechanism with fluorine is similar to reaction of dicarbonyls with other halogens via the enol derivatives. The rate of the reaction depends of the rate of enolisation.

Enolisation mechanism for the 2,4-pentanedione⁵⁵

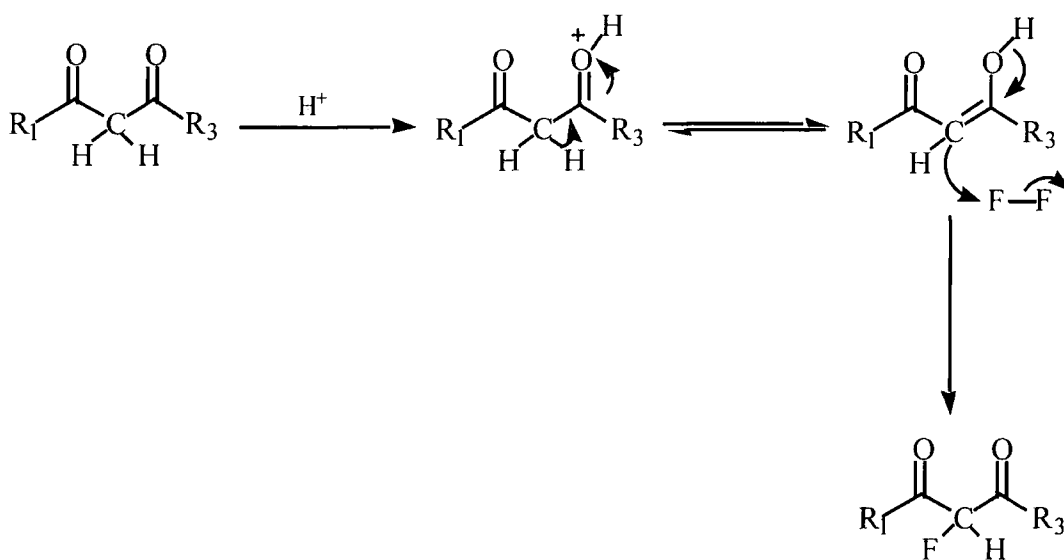

Scheme 1.29

1.6. Fluorination using Selectfluor™ (F-TEDA-BF₄)

As the second part of this thesis we have investigated the fluorination of organic compounds using NF reagents and particularly Selectfluor™ in order to compare with fluorination using elemental fluorine.

1.6.a. Historical Background of the N-F Reagents

The electrophilic fluorinating potential of N-F bonds was first discovered more than 30 years ago by Banks and Williamson⁵⁶. They showed that perfluoro-*N*-fluoropiperidine (**4**) could convert the sodium salts of 2-nitropropane and diethyl malonate to 2-fluoro-2-nitropropane and diethyl difluoromalonate respectively. A nucleophilic displacement on the fluorine of the NF group in (**4**) explained these results (Scheme 1.30, pathway A)^{56, 57}. Later^{58, 59}, an alternative electron-transfer mechanism was also postulated (Scheme 1.31, pathway B).

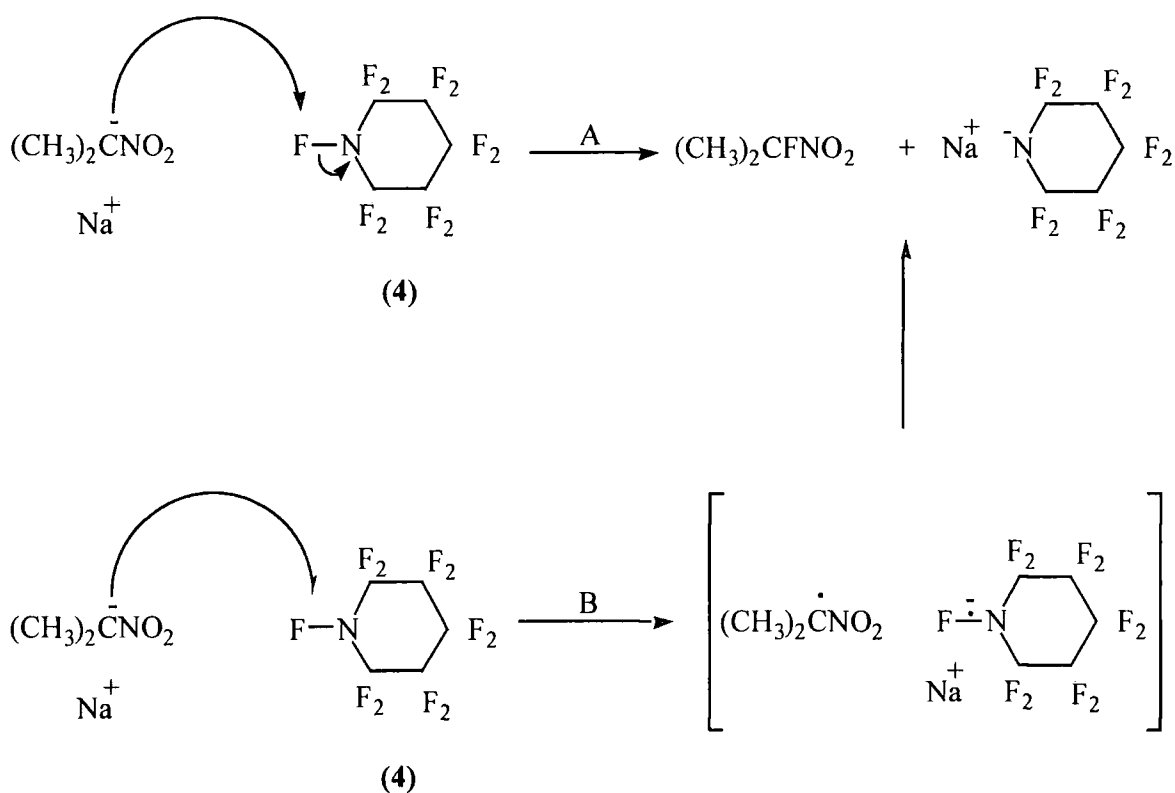

Scheme 1.30

Perfluoro-*N*-fluoropiperidine (**4**) was developed further because of its selective electrophilic potential but has never got any real status on a widely used reagent. This is due to its low yield method of preparation (Simons ECF or pyridine in HF) and the extensive analogous work with hazardous OF reagents⁶⁰ (CF₃OF) and then, with xenon difluoride^{61, 62} (easily-handled).

Great interest in NF reagents really began in the early 1980s when several papers concerning *N*-fluoropyridin-2 (1*H*)-one ((**5**); Purrington's reagent)⁶³, *N*-fluoro-*N*-alkylsulfonamide ((**6**); Barnette reagents)⁶⁴, *N*-fluoropyridinium salts ((**7**); Umemoto reagents)^{65, 66} and *N*-fluoroquinuclidinium fluoride ((**8**); UMIST reagent)⁶⁷ (the latter two more reactive than (**5**) and (**6**)) were published. The interest in NF reagents was also due to the introduction of the most powerful 'F⁺' delivery agent of the NF class, *N*-fluorobis(trifluoromethylsulfonyl)imide ((**9**); DesMarteau's reagent)⁶⁸.

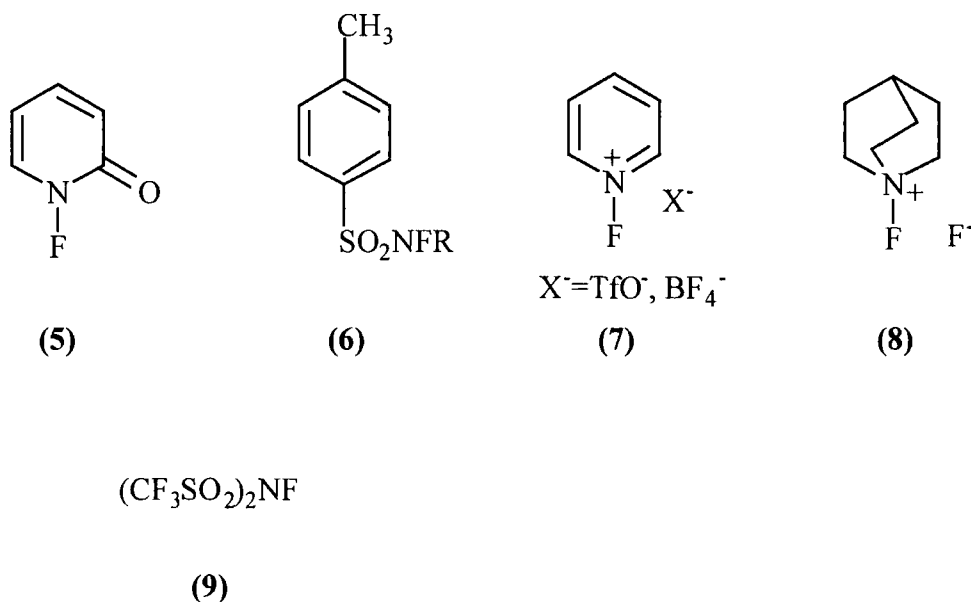

Scheme 1.31

The SelectfluorTM family was discovered about 7 years ago by Banks and co workers. The generic structure of SelectfluorTM, below, is based on the TEDA (=Triethylenediamine) moiety. The electrophilicity of the N-F bond can be higher or lower by simply increasing or decreasing the electron withdrawing strength of the R group⁶⁹.

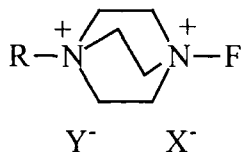

Generic structure of Selectfluor™

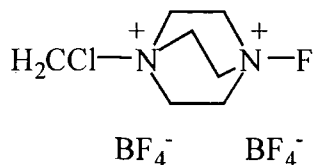

Commercial Selectfluor™

Scheme 1.32

1.6.b. Properties of F-TEDA-BF₄^{70, 71}

Selectfluor™ reagent F-TEDA-BF₄ is a white, free-flowing, vitually non-hygroscopic, high melting (apparent m.p. 190°C) crystalline solid. It is recommended that it is stored in a cool dry place and not heated above 80°C. A solution of F-TEDA-BF₄ in dry acetonitrile loses less than 10% of its activity ('F⁺' transfer capability) when heated under reflux (82°C) for 1 day⁷⁰.

It is very soluble in water or dilute hydrochloric acid. It is decomposed by dilute sodium hydroxide and reacts with cold DMSO (rapidly and exothermically) and with DMF (slowly on heating) to give as yet unidentified products. It is reasonably soluble in acetonitrile but only slightly in alcohols or acetone. The oral toxicity of Selectfluor™ is classed as moderate.

1.6.c. Synthesis of F-TEDA Reagents and their 'F⁺' Delivery Potential

The methodology used to synthesise TEDA moieties (10) and to convert them into NF-TEDA are showed in Schemes 1.33 and 1.34 respectively; Scheme 1.35 presents a few applications of these reagents for the fluorination of various organic compounds.

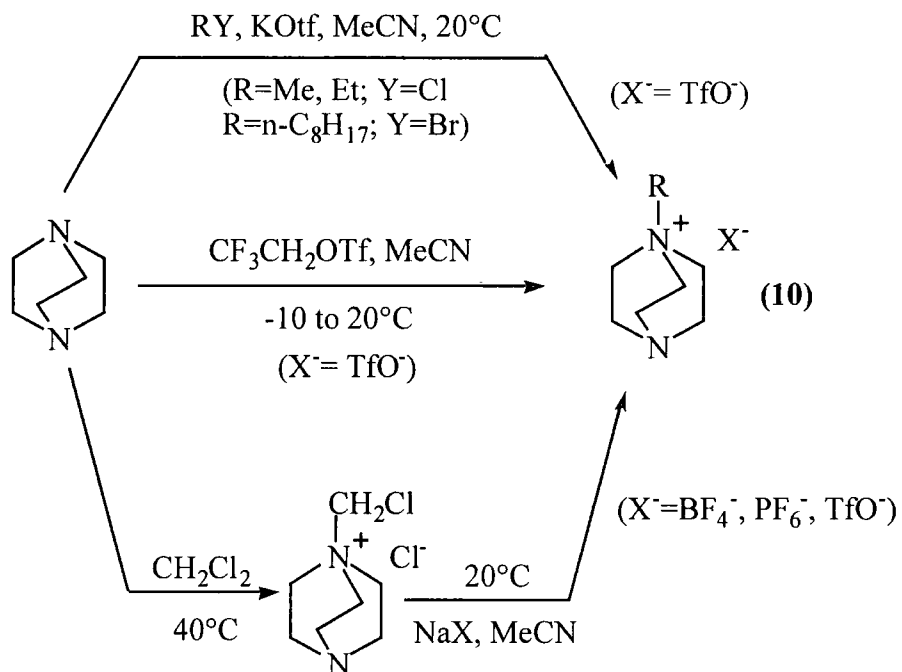

Scheme 1.33 Synthesis of TEDA monoquats⁷²

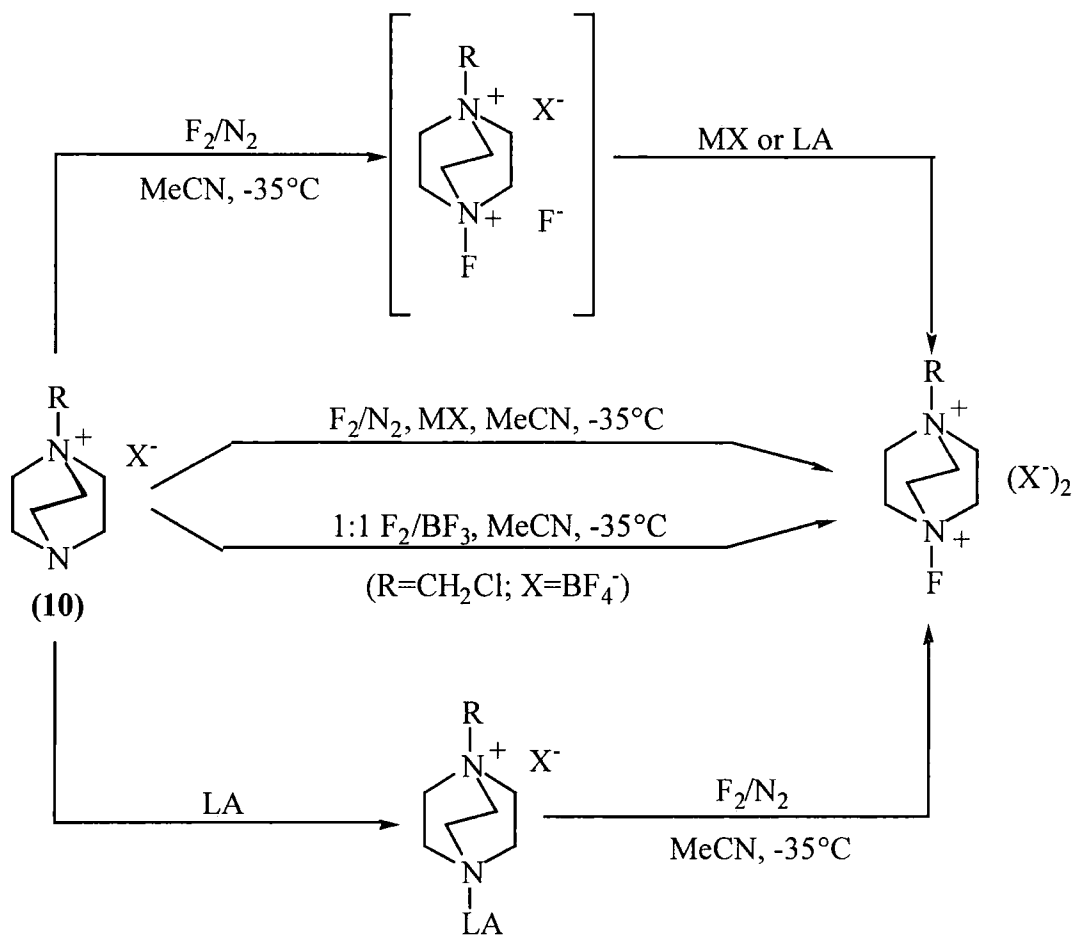

MX=NaBF₄, NaPF₆, LiOTf *etc*;

LA=Lewis acid=X⁻, F⁻ (X⁻=BF₄⁻, PF₆⁻ salts)

Scheme 1.34 Synthesis of F-TEDA salts⁷⁰

The tetrafluoroborate salts seem to be the best for commercialisation for cost-effectiveness reasons. Fluorinating power was found to increase when increasing the electron-withdrawing power of the alkyl group R (CH₃, C₂H₅, C₈H₁₇<CH₂Cl<CF₃CH₂)⁷⁰,

73.

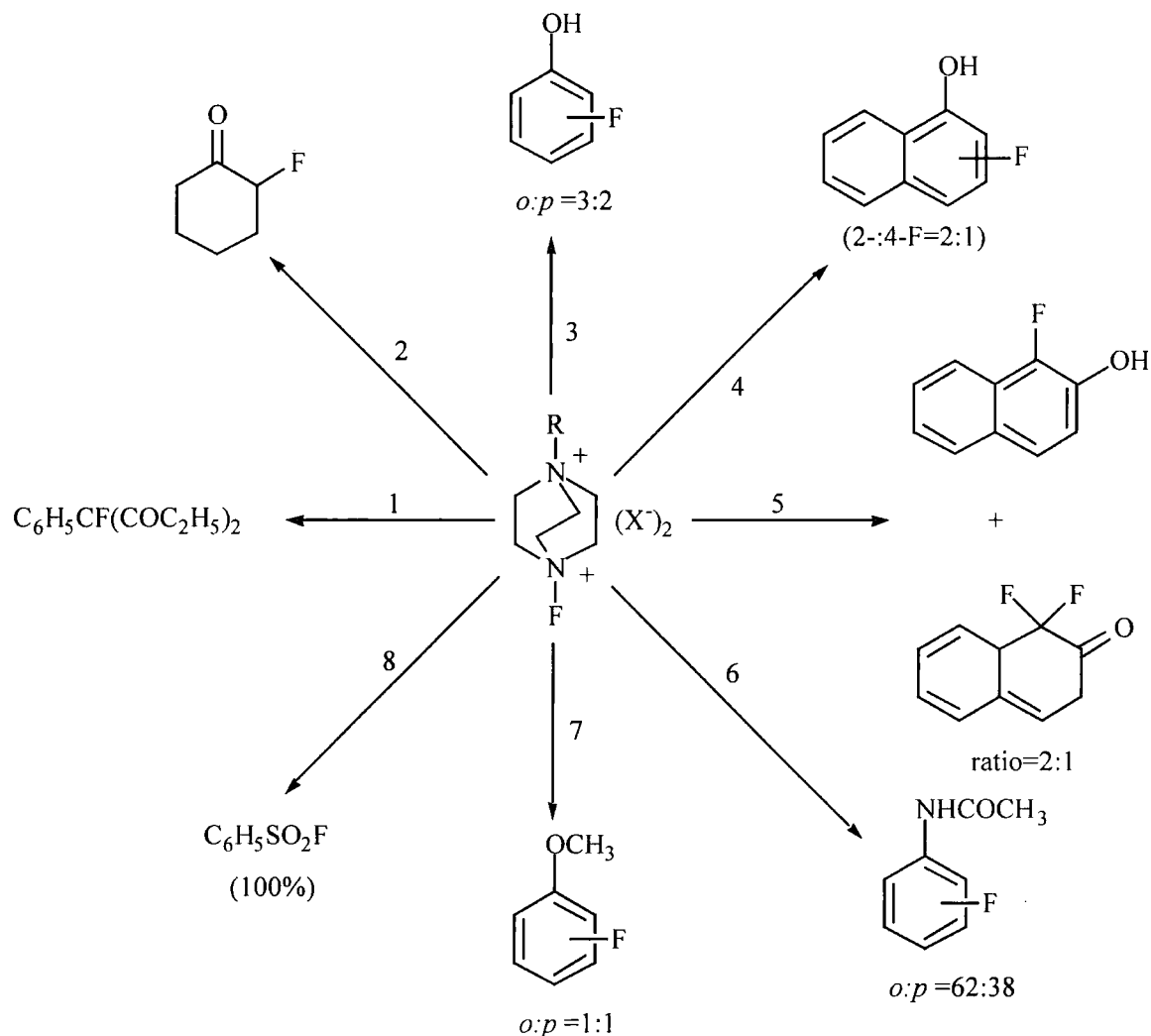

1 $C_6H_5CH(CO_2Et)_2$, Na^+ in THF, -10 to 20°C; **2** 1-morpholinocyclohexene in DCM, -196 to 20°C then HCl aq; **3** C_6H_5OH in CH_3OH , 20°C; **4** 1-HOC₁₀H₇ (50% excess) in CH_3OH , -196 to 20°C; **5** 2-HOC₁₀H₇ in CH_3OH , -196 to 20°C; **6** $C_6H_5NHCOCH_3$ (100% excess) in boiling CH_3CN ; **7** $C_6H_5OCH_3$ in wet CH_3CN , 40°C; **8** $C_6H_5SO_2Na$ in CH_3CN , 20°C.

Scheme 1.35 Electrophilic fluorination using F-TEDA salts

1.6.d.Applications of F-TEDA-BF₄ in C-F Bond Synthesis

Lots of reactions using Selectfluor™ have been carried out since 1992 due to its rapid commercialization^{74, 75}. Examples of the use of this electrophilic fluorinating reagent for fluorination reaction are reported below.

1.6.d.i. Electrophilic Fluorination of Aromatics

Aromatics with electron releasing groups to facilitate fluorination^{71, 73} react with F-TEDA-BF₄ under reasonable conditions to give mono- and difluorinated derivatives. Few examples of mono and disubstituted aromatics are presented below (Scheme 1.36).

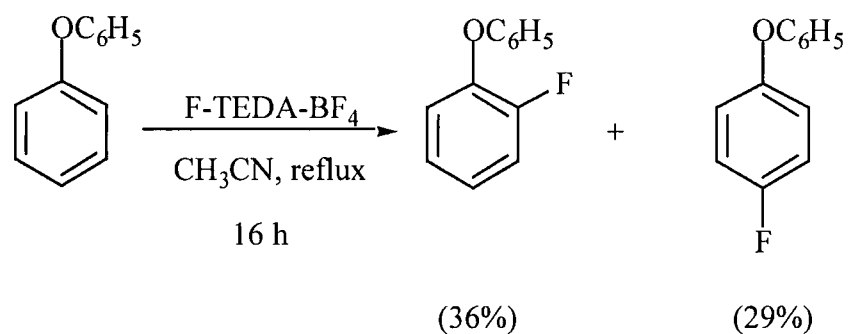
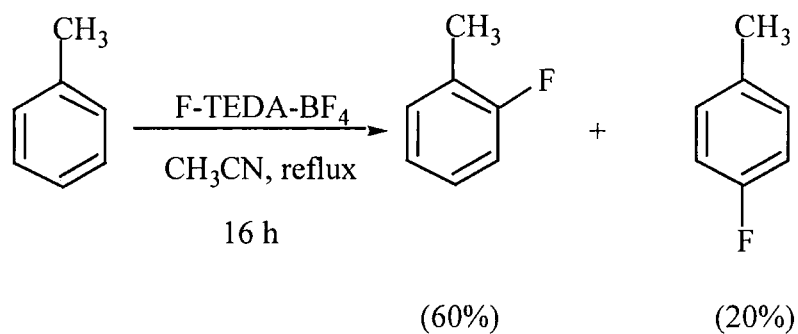

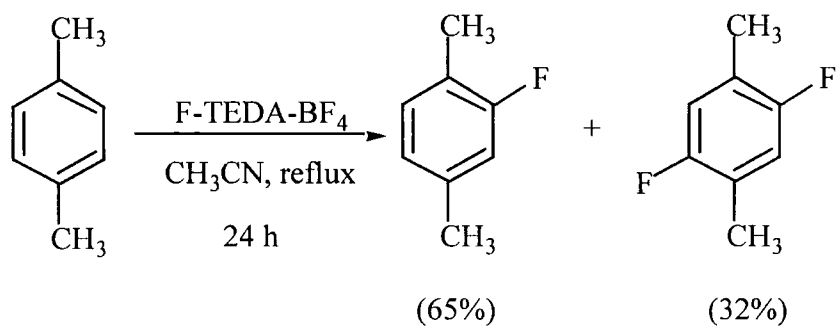

Scheme 1.36

The regioselectivity of the fluorination of anthraquinones using F-TEDA-BF₄ is important because of research on non-steroidal anti-inflammatory drugs. This has been discovered by doing some fluorination of the deactivated substrate methyl 4,5-dimethoxy-9,10-anthraquinone-2-carboxylate⁷⁶ (Scheme 1.37).

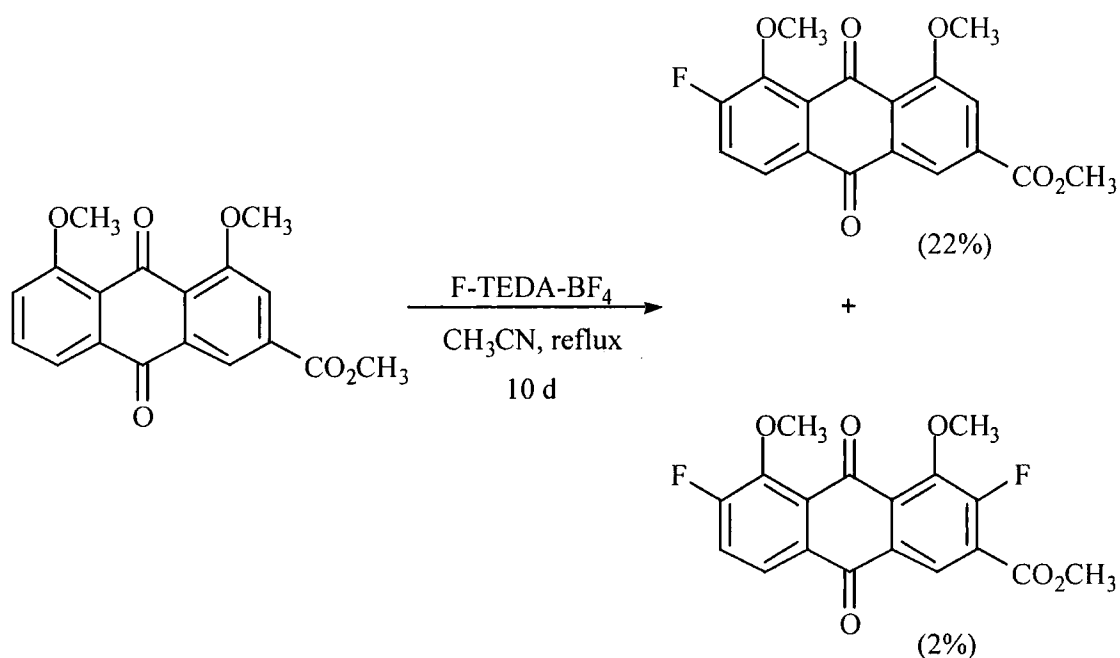

Scheme 1.37



1.6.d.ii. α -Fluorination of Sulfides

Recently, α -fluoro sulfides have proved to be an important part of fluorinated compounds. In fact, they are very valuable in modifying the biological activity of β -lactam antibiotics⁷⁷ and amino acids⁷⁸. Finally, they are useful synthetic intermediates for medicinally active compounds⁷⁹.

Synthesis of fluoromethyl phenyl sulphide using XeF_2 with thioanisole⁸⁰ was reported by Zupan. The conversion of sulphides bearing α -hydrogen atoms to the α -fluoro sulphides was performed by Umemoto and Tomizawa using *N*-fluoropyridinium salts⁸¹.

It has been demonstrated that sulphides containing α -hydrogens react rapidly with F-TEDA- BF_4 in MeCN at room temperature giving rise to the fluorosulfonium salt which react with a base to produce the α -fluoro sulfide⁸¹ (Scheme 1.38).

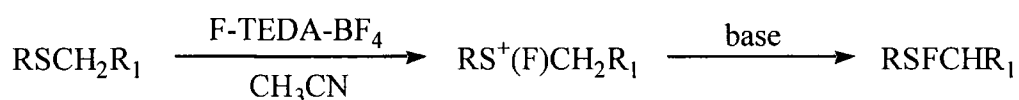

Scheme 1.38

This process was applied to a range of aryl and alkyl sulphides (Scheme 1.39) in order to produce the fluorinated products in moderate yields. The fluorination of the aromatic sulphides forming monofluorinated products was fast and easy due to the nucleophilicity of the sulfur atom. Because of the instability of the α -fluoro sulphides to standard chromatography purification techniques, they were isolated as the corresponding sulfoxide (with NBS, H_2O) or sulfone (with MCPBA).

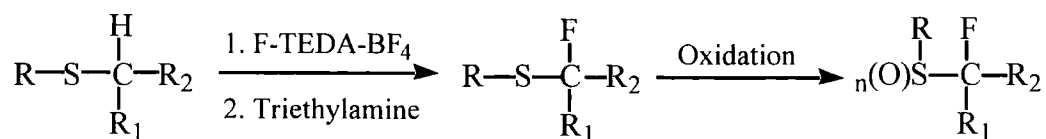

Scheme 1.39

Few examples of the synthesis of 2-fluoro sulfide, sulfoxide or sulfone

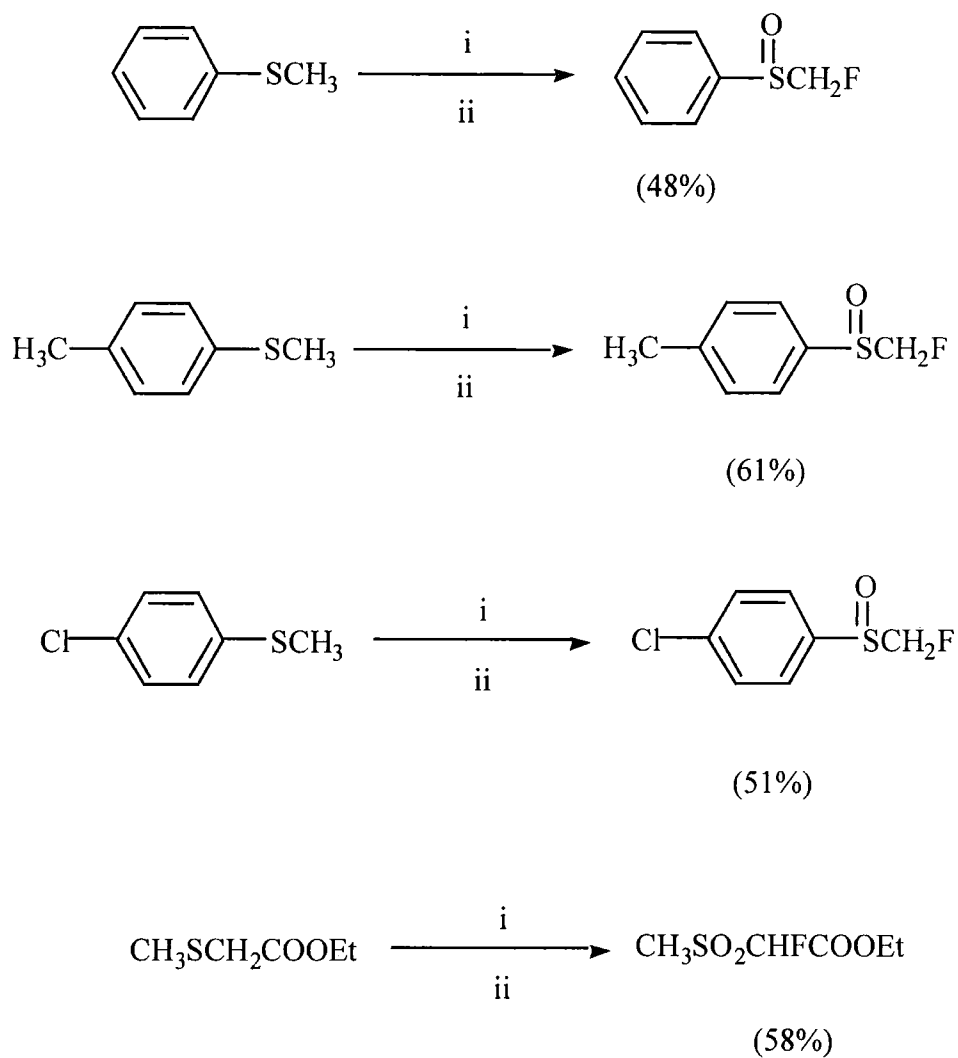

Scheme 1.40

i=F-TEDA-BF₄, triethylamine.
ii=MCPBA.

1.6.d.iii. Synthesis of α -Fluoro Carbonyl Compounds

Having a fluorine atom in the alpha position to a carbonyl group increases the electrophilicity of the carbonyl carbon atom and then, facilitates nucleophilic additions. Organic compounds containing an α -fluoro carbonyl moiety are important due to their applications in research on bioactive molecules⁸².

1) Via β -Dicarbonyl Compounds

The direct conversion of 1,3-dicarbonyl compounds to mono and difluoro derivatives using F-TEDA-BF₄ was realised by Banks and co-workers under neutral conditions⁸³.

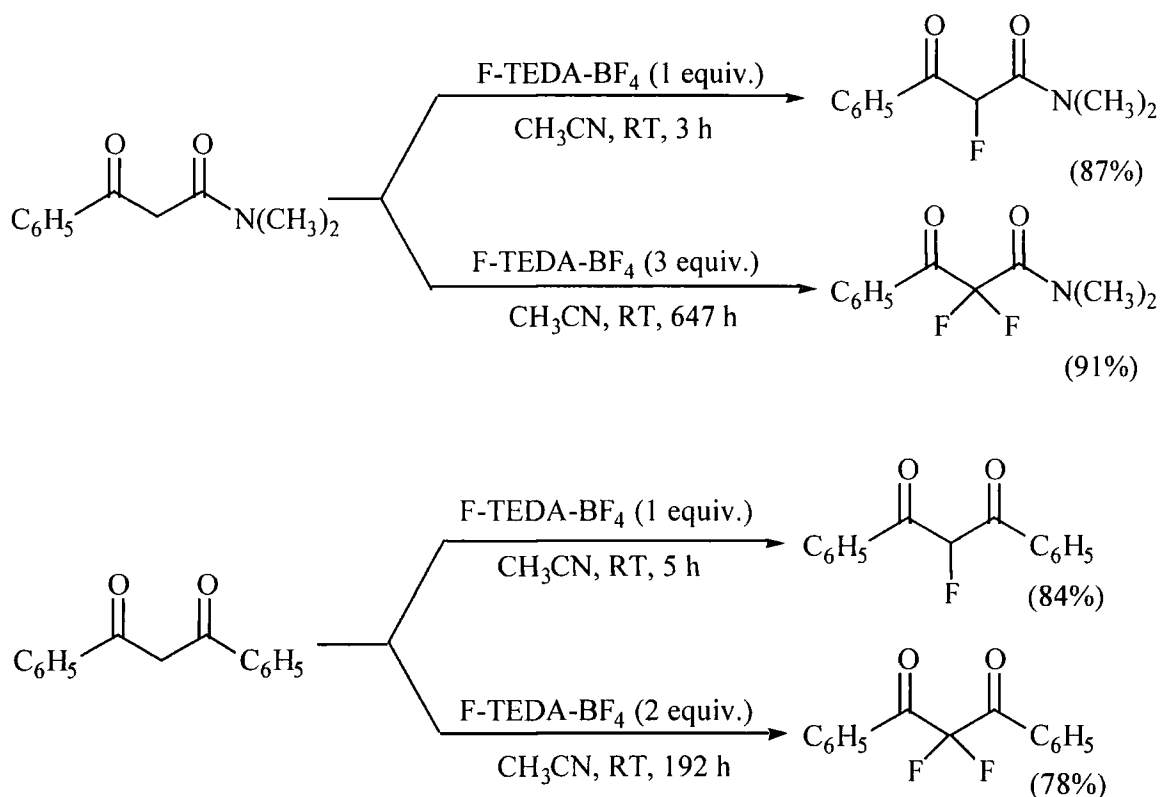

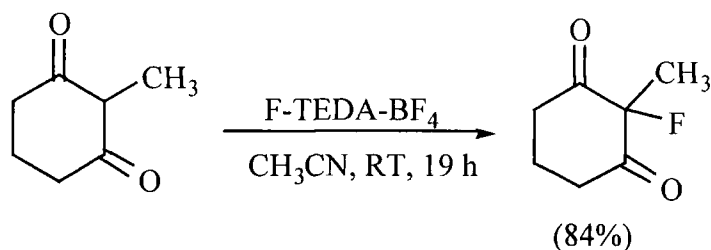
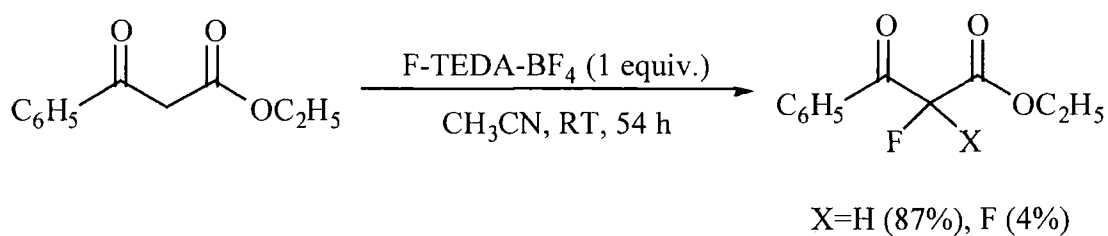

Scheme 1.41

2) Via Enol Ethers, Enamines and Imines

α -Fluoro carbonyl compounds can also be prepared via fluorination of enol ethers, enol acetates and silyl enol ethers using a variety of N-F agents, followed by hydrolysis

(Scheme 1.42). Selectfluor™ seems to be the most common electrophilic fluorinating agents used to perform this transformation^{5, 84, 85}.

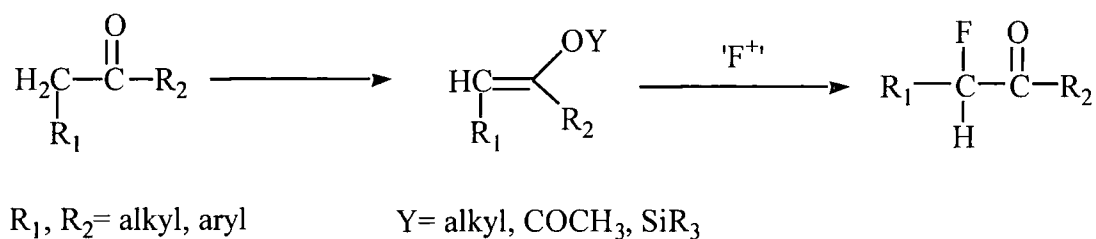

Scheme 1.42

The electrophilic fluorination of enamines (Scheme 1.41) using Selectfluor™ and other N-F reagents followed by hydrolysis is a good way of making α -fluoro ketones^{5, 84, 85} as well.

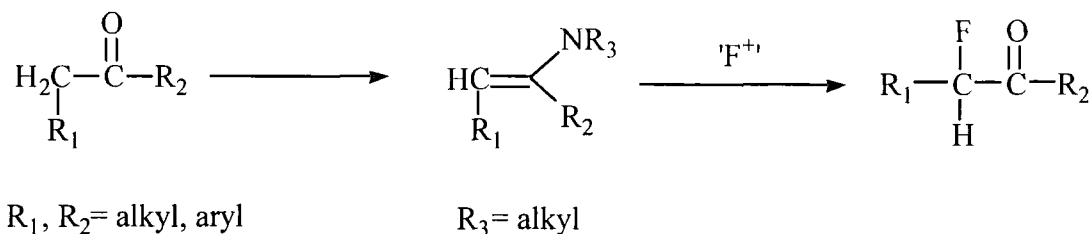

Scheme 1.43

3) Via Fluorination of Alkynes

The fluorination of substituted phenylacetylenes using Selectfluor™ in refluxing MeCN/H₂O reported by Zupan and co-workers gave rise to α, α -difluoroketones (Scheme 1.44).

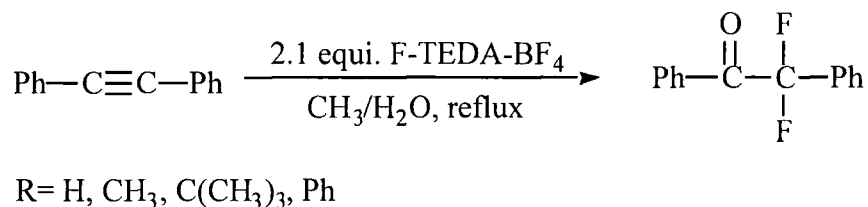

Scheme 1.44

1.6.d.iii. Fluorination at Saturated Sites

The transformation of secondary and tertiary C-H bonds using Selectfluor™ was studied by Chambers and co-workers⁴⁴.

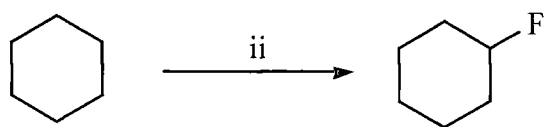

100% conv., 22% yield

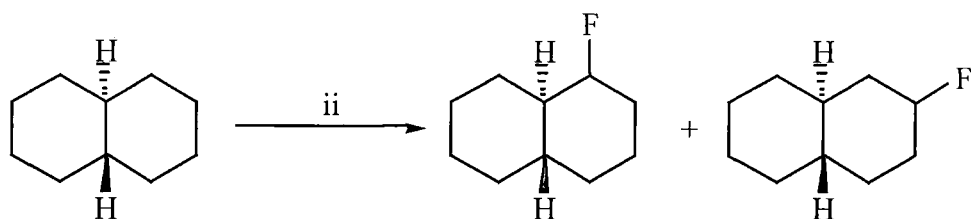

81% conv., 23% yield

i=SelectfluorTM, MeCN, reflux, 3.5-16h.

Scheme 1.45

It has been observed that the fluorination of decalin using this N-F reagent took place on the secondary site rather than primary site as observed when fluorine was used. This could be due to the big size of SelectfluorTM and consequently a greater steric requirement.

1.6.e. Mechanistic Studies

To understand the mechanism of N-F reagents⁸⁶⁻⁹¹ several recent studies have been carried out. These are based on kinetics, electrochemistry or radical trapping. If fluorination proceeded following a SET (Single Electron Transfer) a radical site next to the cyclopropane would be formed and ring opening would occur. If an electrophilic process (Two Electron Transfer) occurred during the reaction the derivative (12) would be observed (Scheme 1.46).

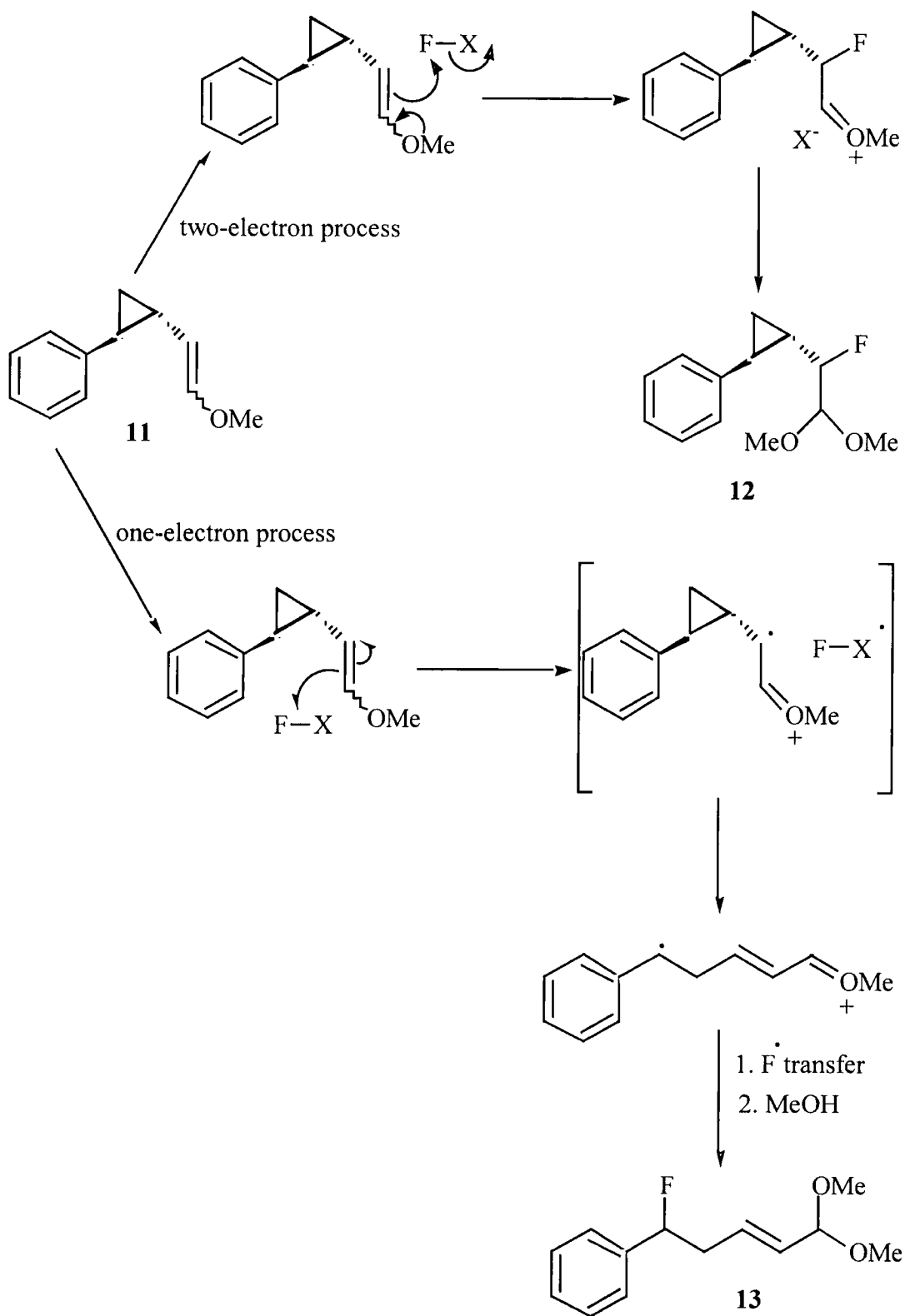

Scheme 1.46

As shown in Scheme 1.46, if the process proceeds via a heterolytic N-F cleavage, the cyclopropyl moiety will not be opened, yielding the α -fluoro acetal (**12**). If a radical intermediate is involved in this process, it should rearrange and give compounds such as (**13**). The mechanism suggested by Umemoto et al⁹¹ involves a SET and subsequent F[•] transfer. It was found that the expected fluorinated dimethoxy acetal (**12**) was obtained in 45% yield with no rearrangement occurring. Other fluorinating reagents have been compared using the same reaction to identify SET or Two Electron Transfer (Table 1.5).

Fluorinating reagent	Nucleophile	Product (yield)	Mechanism
F-TEDA-BF ₄	MeOH	12 (45%)	Two- electron
<i>N</i> -fluoropyridinium Salt	MeOH	No reaction	Not determined
XeF ₂	No nucleophile	Various olefins Cyclopropyl dissapearance	One-electron

Table 1.5

The reaction with xenon difluoride (XeF₂) provided several compounds containing olefins and ring-opened compounds. These data agree with the fact that xenon difluoride can give rise to a radical process. *N*-fluoropyridinium gave no reaction under its optimal conditions.

These mechanistic experiments conclude that Selectfluor™ proceeds via a two-electron mechanism in reaction with vinyl ethers.

1.7. Conclusion

We have seen that organofluorine compounds were highly useful but they rarely occur in nature. To be prepared, elemental fluorine and Selectfluor™ can be used.

Selective direct fluorination can be achieved by encouraging both of these reagents to act as electrophiles.

In the next Chapters, we have reviewed our studies concerning the electrophilic fluorination of hydrocarbon systems using both elemental fluorine and Selectfluor™.

Chapter Two: Fluorination of Ketones

2.1. Introduction

In this Chapter we have studied the fluorination of cyclic and acyclic ketones using both elemental fluorine and Selectfluor™ and compare our results with the literature^{92, 93}. The presence of an electron withdrawing group (ewg) should decrease the electron density of the adjacent C-H bond and therefore the fluorination would occur further away from the ewg.

2.2. Fluorination of Ketones using Selectfluor™

2.2.a. Acyclic Ketones

2.2.a.i. 2-Heptanone

Fluorination of 2-heptanone using Selectfluor™ was carried out by heating a solution containing a small excess of Selectfluor™ and 2-heptanone in acetonitrile for 18h. The ¹⁹F NMR showed the presence of one main peak corresponding to the 3-fluoro-2-heptanone (**14**) (85% conv., 56% isolated yield) and other unidentified by-products. The α -fluoro derivative was isolated using preparative GC and subject to full characterisation.

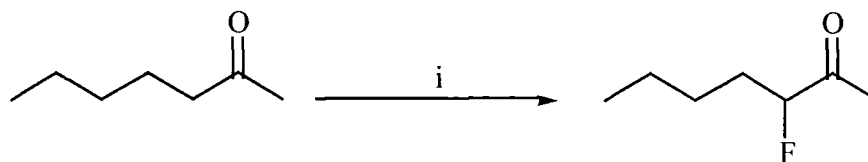

(14)

85% conv., 56% isolated yield

i=1.1 eq of Selectfluor™, MeCN, 82°C, 18h.

Scheme 2.1

The structure of the compound has been determined using mainly ^{13}C NMR and the ^{19}F NMR. The carbonyl resonance detected at $\delta_{\text{C}}=208.6\text{ppm}$ was found to have a coupling constant of 25Hz which is consistent with a two-bond coupling constant between the carbon and fluorine^{94, 95}.

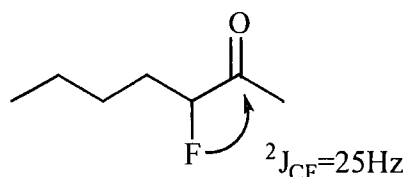

Scheme 2.2

^{13}C - ^{19}F Couplings	Values (Hz)
$^1\text{J}_{\text{CF}}$	158-400
$^2\text{J}_{\text{CF}}$	20-40
$^3\text{J}_{\text{CF}}$	Up 42

Table 2.1 ^{13}C - ^{19}F Coupling Constants⁹⁵

2.2.a.ii. 2-Octanone

Fluorination of 2-octanone using SelectfluorTM was also carried out by heating a solution containing a small excess of SelectfluorTM and 2-octanone in acetonitrile for 18h. The ^{19}F NMR showed the presence of one major peak corresponding to the 3-fluoro-2-octanone (**15**) (84% conv., 65% isolated yield) which was also isolated using preparative GC.

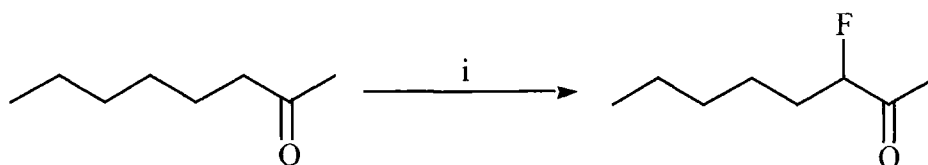

(15)

84% conv., 65% isolated yield

$i=1.1$ eq of SelectfluorTM, MeCN, 82°C, 18h.

Scheme 2.3

For the same reason seen previously, the 3-fluoro-2-octanone was identified from the ¹³C NMR. Here again, the carbonyl signal ($\delta_C=208.8$ ppm) was seen to be a doublet with a coupling constant of 25Hz. Therefore, the fluorine is on the carbon atom next to the carbonyl.

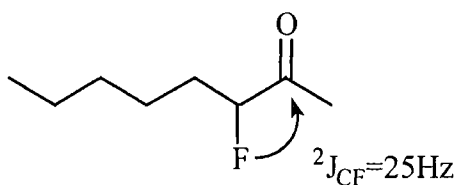

Scheme 2.4

The direct formation of α -fluoro derivatives⁹² from ketones encouraged us to investigate the fluorination of a diketone. The presence of two ewg should decrease the electron density on the adjacent C-H bond even more.

2.2.a.iii. 2,5-Hexanedione

Fluorination of 2,5-hexanedione using Selectfluor™ was attempted by heating a solution containing a small excess of Selectfluor™ and 2,5-hexanedione in acetonitrile for 18h. The ^{19}F NMR showed the presence of the 3-fluoro-hexan-2,5-dione (**16**) (84% conv., 65% isolated yield) and another minor product in the ratio 8:1. Purification by column chromatography using 2:1 hexane/ethyl acetate was performed and gave a mixture of the 3-fluoro-hexan-2,5-dione as well as hex-3-ene-2,5-dione (**17**), formed by elimination of HF, in the ratio 2.2:1.

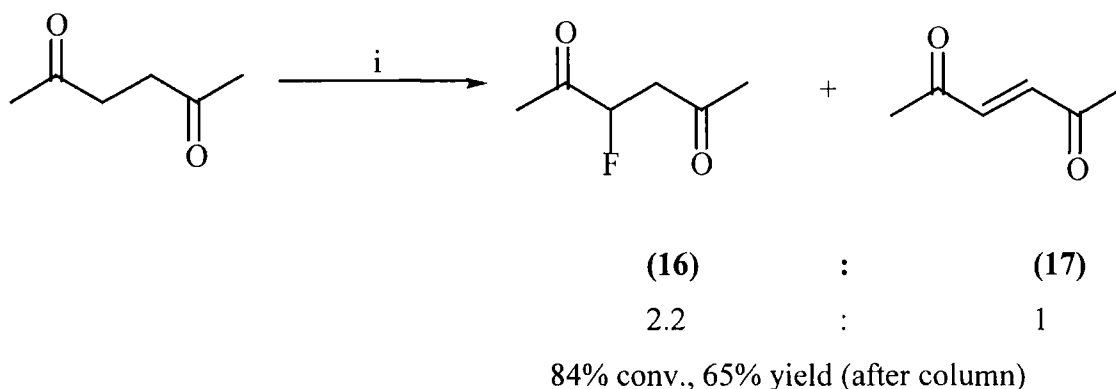

i=1.1 eq of Selectfluor™, MeCN, 82°C, 18h.

Scheme 2.5

The fluorination of acetyl acetone occurred at the alpha position to the carbonyl and this was also established by ^{13}C NMR as well. The carbonyl signal ($\delta_{\text{C}}=207.3\text{ppm}$) was found as a doublet with a coupling constant of 25.2Hz.

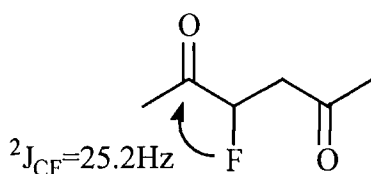

Scheme 2.6

The formation of the hex-3-ene-2,5-dione is due to dehydrofluorination of 3-fluoro-hexan-2,5-dione during column chromatography (acidic medium).

We have established that the electrophilic fluorination of acyclic ketones using Selectfluor™ led to the formation of α -fluoro derivatives and therefore, the same methodology was applied to a range of cyclic ketones.

2.2.b. Cyclic ketones^{52, 92}

2.2.b.i. Cyclopentanone

Fluorination of cyclopentanone using Selectfluor™ was performed by heating a solution containing a small excess of Selectfluor™ and cyclopentanone in acetonitrile for 18h. The ¹⁹F NMR of the crude product obtained after work-up showed the presence of the 2-fluoro-cyclopentanone (**18**) (84% conv., 58% isolated yield) only. Purification by column chromatography using 1:1 hexane/ethyl acetate was carried out and the product was submitted to full characterisation (consistent with the literature^{52, 92}).

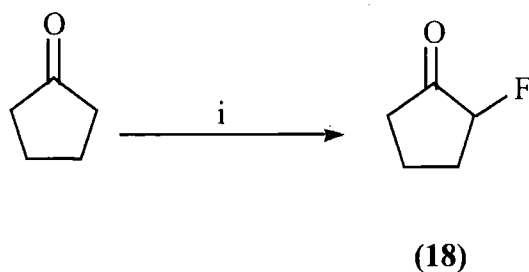

84% conv., 58% isolated yield

i=1.1 eq of Selectfluor™, MeCN, 82°C, 18h.

Scheme 2.7

The carbonyl signal was detected as a doublet ($\delta_C=211.9\text{ppm}$) having a coupling constant of 13.4Hz, slightly smaller than the one observed for the acyclic ketones but still consistent with a two-bond coupling between fluorine and the carbonyl.

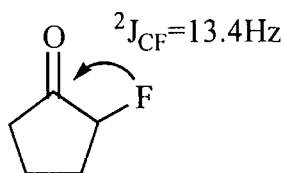

Scheme 2.8

2.2.b.ii. Cyclohexanone

Fluorination of cyclohexanone using SelectfluorTM was performed following the same process. The ¹⁹F NMR of the crude product obtained after work-up showed the presence of the 2-fluoro-cyclohexanone (**19**) (93% conv., 59% isolated yield) only. Purification of the crude product was achieved by column chromatography using 2:1 hexane/ethyl acetate and characterised using the same method as above.

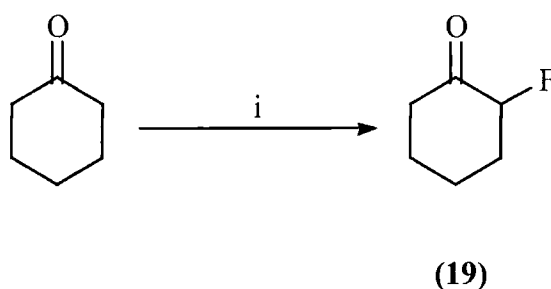

93% conv., 59% isolated yield

i = 1.1 eq of SelectfluorTM, MeCN, 82°C, 18h.

Scheme 2.9

2.2.b.iii. Cycloheptanone

Finally, fluorination of cycloheptanone using SelectfluorTM was carried out using the same process. The ¹⁹F NMR of the crude product obtained after aqueous work-up showed the presence of the 2-fluoro-cycloheptanone (**20**) (73% conv., 56% isolated yield) only. Purification of the crude product was performed by column chromatography

using 2:1 hexane/ethyl acetate and characterisation of the product was carried out following the procedure described above.

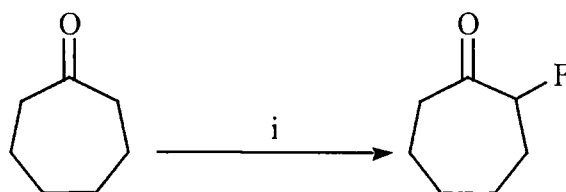

(20)

73% conv., 56% isolated yield

i=1.1 eq of Selectfluor™, MeCN, 82°C, 18h.

Scheme 2.10

2.2.c. Mechanism

It has been seen that the fluorination of both acyclic and cyclic ketones led to the direct formation of α -fluoro carbonyl derivatives. The postulated mechanism is the following (Scheme 2.11).

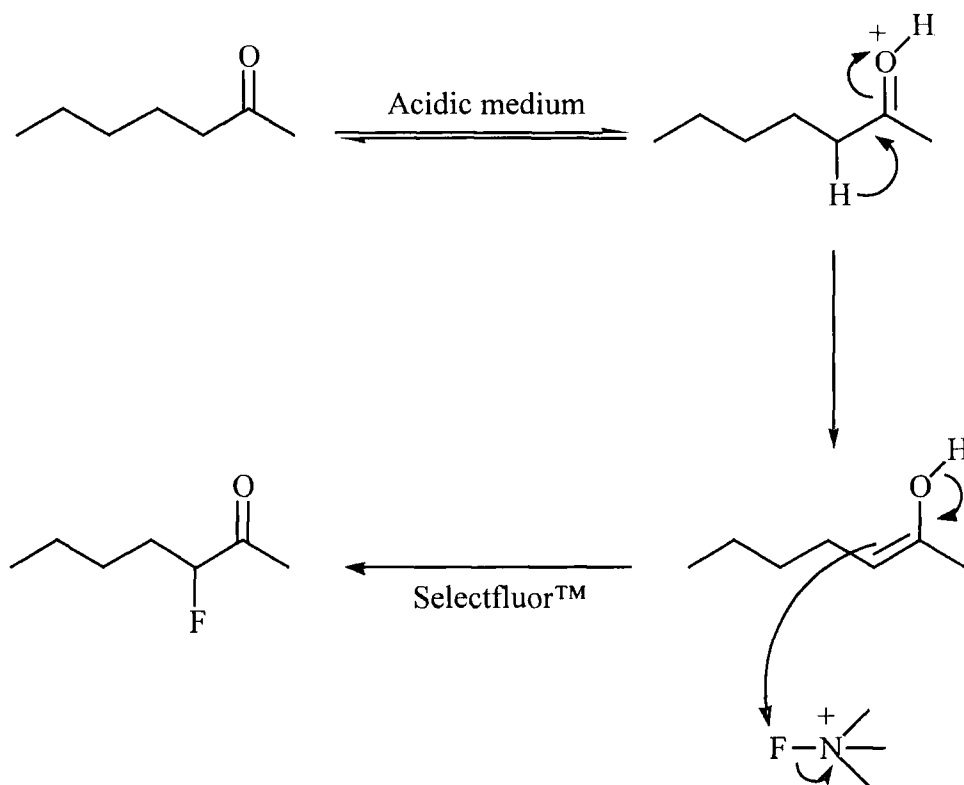

Scheme 2.11

The reaction medium is acidic due to Selectfluor™. Therefore, the protonation of the carbonyl leads to formation of the enol derivative. This reactive species would react with N-F following an electrophilic process giving rise to the α -fluoro carbonyl derivative. Previous studies⁹⁶ showed that the enol content is at a maximum for cyclohexanone and at a minimum for cycloheptanone and cyclopentanone. That could explain the difference in conversion (the highest was observed for cyclohexanone and the lowest for cycloheptanone). These reactions are regioselective and selective because the fluorination occurred only at the alpha position to the carbonyl.

The second part of this discussion chapter reports the direct fluorination of acyclic and cyclic ketones using elemental fluorine to compare the results with the one observed when Selectfluor™ was used.

2.3. Fluorination of Ketones using Fluorine

2.3.a. Acyclic ketone

2.3.a.i. 2-Heptanone

Direct fluorination of 2-heptanone was carried out by passing an excess of fluorine through a cooled (0°C) solution of 2-heptanone and dry acetonitrile. After the usual aqueous work-up the crude product obtained contained 5- and 6-fluoro-2-heptanone ((**21**) and (**22**)) detected by ¹⁹F NMR (67% conv., 47% isolated yield) in the ratio 1:1.1. Purification was achieved by preparative GC and the products were obtained as a mixture of isomers which could not be separated. They were submitted to full characterisation.

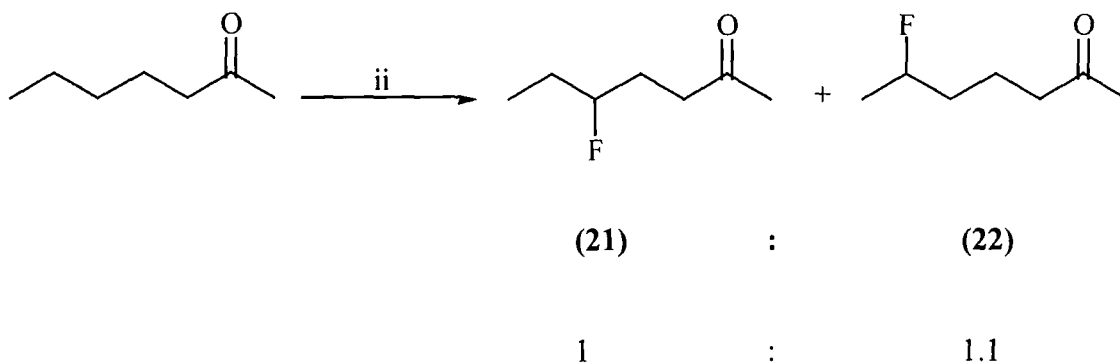

67% conv., 47% isolated yield

i=10% F₂/N₂, CH₃CN, 0°C, 24h.

Scheme 2.12

The identity and ratio of the products was determined using ^{13}C and ^{19}F NMR. 6-Fluoro-2-heptanone was identified due to a two-bond coupling constant between the terminal methyl and fluorine.

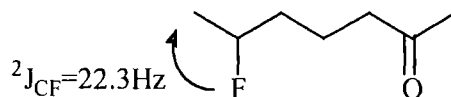

Scheme 2.13

In the present case the fluorination took place further away from the carbonyl (at 5 and 6 position) because the electronegative effect of that one decreases the electron density of the alpha carbon. According to the literature^{51, 52, 94, 95, 97} the direct fluorination of ketones does not give rise to the α -fluoro derivative directly. The α -fluorination of ketones was successful using enol acetates⁹⁴, pyruvic acid derivatives⁵¹, trimethyl silyl derivatives⁵² and hydroxymethylene substituent as directing and activating group⁹⁷.

In the present case we attempted the direct α -fluorination of ketones using several catalysts which could promote the enolization of the ketone in order to produce α -fluoroketones directly.

1). AlCl_3 ⁹⁸

Direct fluorination of 2-heptanone was carried out by passing an excess of fluorine through a cooled (0°C) solution of 2-heptanone, aluminium chloride and dry acetonitrile. After the usual aqueous work-up the crude product obtained contained 5- and 6-fluoro-2-heptanone (**21**) and (**22**) (94% conv., 63% isolated yield) in the ratio 1:1.3. Purification was achieved by column chromatography using 3:1 hexane/ethyl acetate and the products were submitted to full characterisations.

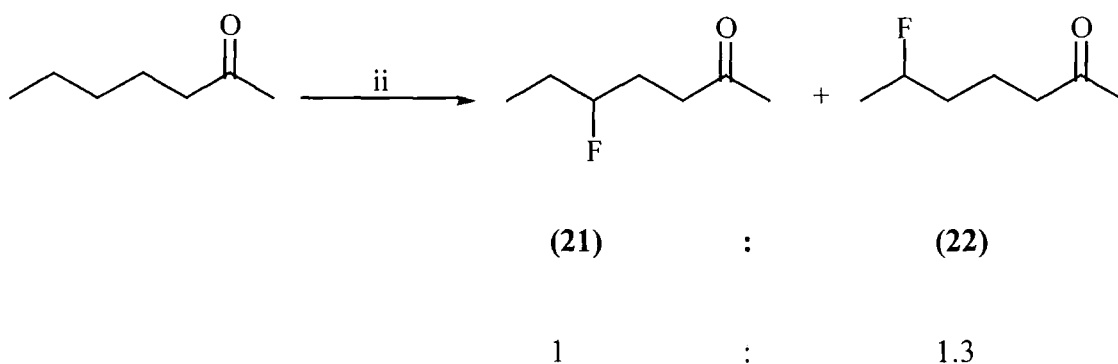

94% conv., 63% isolated yield

i=10% F₂/N₂, AlCl₃, CH₃CN, 0°C, 24h.

Scheme 2.14

No evidence of α -fluorinated derivative was found by ¹⁹F NMR. Nevertheless, a much better conversion was observed (from 47% without AlCl₃ to 94% when used). AlCl₃ accelerated the reaction but did not catalyze the enolization process. This could be due to the fact that the electrophilicity of fluorine was enhanced when in presence of a Lewis Acid as seen below.

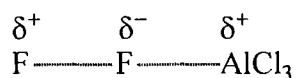

Scheme 2.15

2). Triflic acid

The fluorination of 2-heptanone was performed by passing an excess of fluorine through a cooled (0°C) solution of 2-heptanone, triflic acid (1 and 5 eq) and dry acetonitrile. After the usual aqueous work-up the ¹⁹F NMR of the crude product showed the presence of 5- and 6-fluoro-2-heptanone (**21**) and (**22**) as compared with previous experiment.

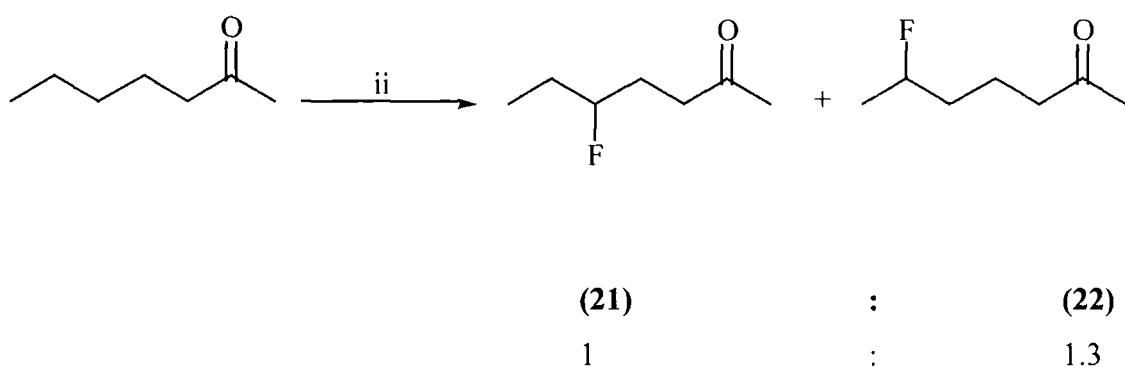

i=10% F₂/N₂, CF₃SO₃H, CH₃CN, 0°C, 5h.

Scheme 2.16

Amount of CF ₃ SO ₃ H used	Conversion (%)	Products observed
1 equivalent	50	5- and 6-fluoro-2-heptanone (1:1.3)
5 equivalents	30	5- and 6-fluoro-2-heptanone (1:3.2)

Table 2.2

Triflic acid did not promote the formation of the enol either. It has been noticed that the conversion dropped down compared to the reference reaction (no catalyst). It seems that triflic acid slowed the reaction down and favours the formation of the 6-fluoro more than the 5-fluoro for unknown reason.

3). Selectfluor™

Because the end product of reactions involving Selectfluor™ is a very strong acid, we added Selectfluor™, in catalytic amount, to determine whether this would influence direct fluorination.

The direct fluorination of 2-heptanone was performed by passing an excess of fluorine through a solution of 2-heptanone, Selectfluor™ and dry acetonitrile. After work-up the crude product was analyzed by ¹⁹F NMR and contained the same products in the ratio 1:1.

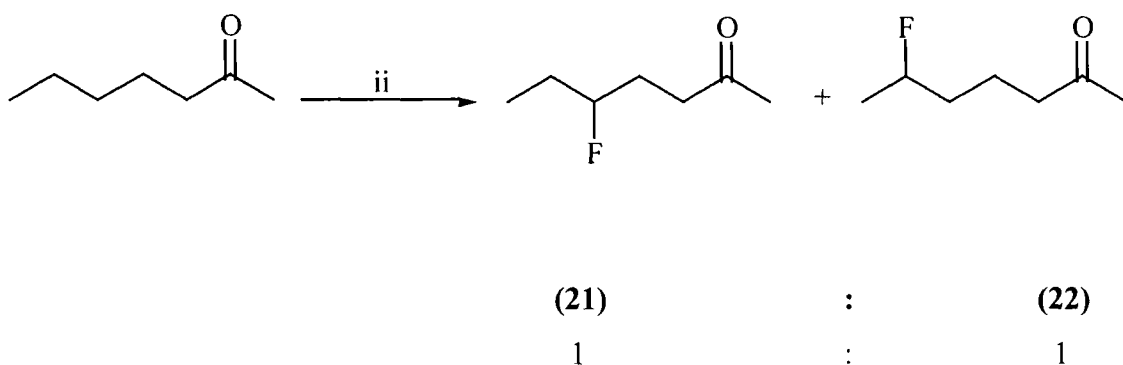

26% conv.,

i=10% F₂/N₂, Selectfluor™, CH₃CN, 0°C, 18h.

Scheme 2.17

Selectfluor™ used in catalytic amount is unable to promote the enolization of the ketone to give rise to the α-fluoroketone.

4). BF₃.Et₂O

Fluorination of 2-heptanone was carried out following the same process and by using some BF₃.Et₂O as catalyst. The ¹⁹F NMR of the crude product obtained after work-up showed the presence of α-fluoroketone as the major product as well as 5-fluoro-2-

heptanone in the ratio 2:1. No evidence of the 6-fluoro derivative was detected on the GC and ^{19}F NMR.

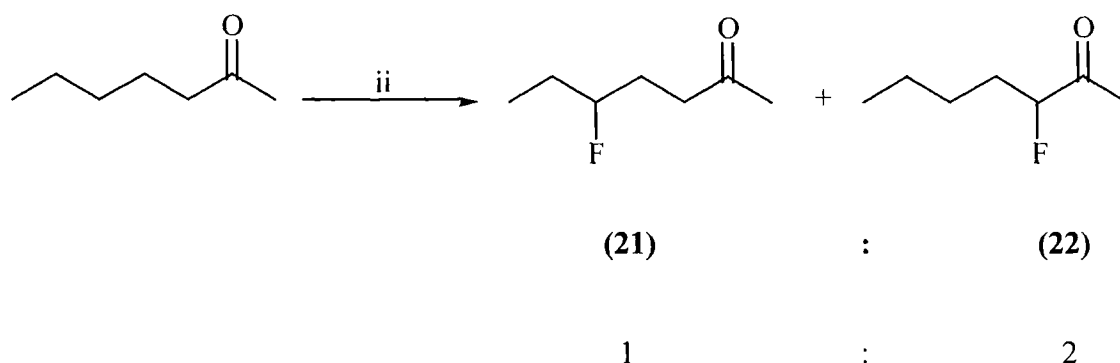

30% conv.,

i=10% F_2/N_2 , $\text{BF}_3 \cdot \text{Et}_2\text{O}$, CH_3CN , 0°C , 18h.

Scheme 2.18

This catalyst seems to promote the enolization of the ketone giving rise to the α -fluoroketone. There should be interaction between the Lewis Acid and the carbonyl as seen below.

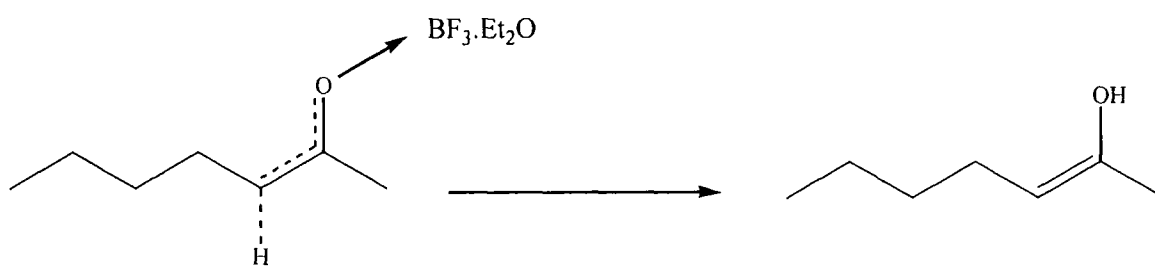

Scheme 2.19

$\text{BF}_3 \cdot \text{Et}_2\text{O}$ is electron-deficient therefore one of the lone electron pairs of the oxygen tends to react with boron. This reaction occurred with a good selectivity.

5). Copper nitrate

The direct fluorination of 2-heptanone was performed using the same process and copper nitrate as catalyst. After the usual aqueous work-up no evidence of 3-fluoro-2-heptanone was shown by ^{19}F NMR. The 5- and 6-fluoro-2-heptanone were detected in the ratio 1:1.

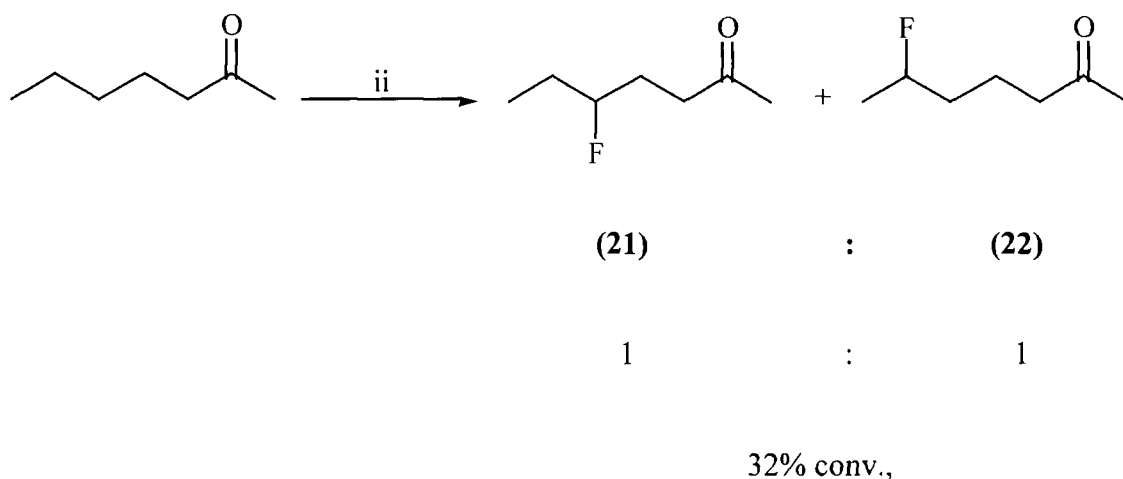

i=10% F_2/N_2 , $\text{Cu}(\text{NO}_3)_2 \cdot 2.5\text{H}_2\text{O}$, CH_3CN , 0°C , 4h.

Scheme 2.20

There was no formation of the 3-fluoro-2-heptanone in that case. Copper nitrate does not favour the enolization process. The fluorination gave a lower conversion than reaction without copper nitrate.

6). Cerium ammonium nitrate (CAN)⁹⁹

The fluorination of 2-heptanone was carried out using the same methodology and CAN as catalyst. After the usual aqueous work-up the ^{19}F NMR of the crude product showed the presence of 3-, 5- and 6-fluoro-2-heptanone (14), (21) and (22) in the ratio 1:14:15.

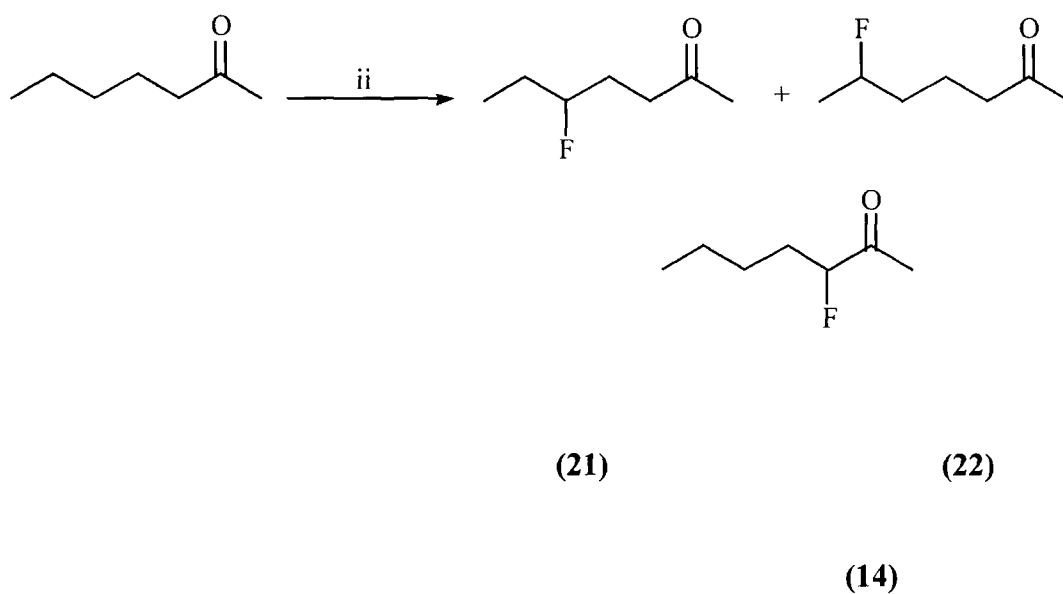

(14):(21):(22), 1: 14: 15

20% conv.

i=10% F₂/N₂, CAN, CH₃CN, 0°C, 4h.

CAN=(NH₄)₂Ce(NO₃)₆

Scheme 2.21

The conversion of the reaction dropped down to 20% compared to reaction without CAN.

Several conclusions concerning the use of these catalysts can be made. First of all, It has been noticed that Lewis Acids increase the reactivity of fluorine but have little effect on selectivity. Lewis acids seem to interact with fluorine by enhancing its electrophilicity rather than influencing the enol formation.

Because Lewis Acids have an influence on the reactivity, they favour an electrophilic process (S_E2).

An S_E2 process would be retarded by adjacent carbonyl: positions remote would be more reactive. It could explain the fact that relatively little enol would be formed. We cannot

rule out entirely a radical process because reaction of an electrophilic radical would also be retarded by the carbonyl.

The final point is that fluorine is much less selective than Selectfluor™ because it is much more reactive.

2.3.a.ii. 2,5-Hexanedione

The direct fluorination of 2,5-hexanedione was performed by passing an excess of fluorine through a solution of 2,5-hexanedione and acetonitrile. After an aqueous work-up the crude product obtained was analyzed by ^{19}F NMR. The 3-fluoro-hexan-2,5-dione (**16**) and 5 other unidentified fluorinated products in the ratio 1.2:1:2:1.7. Consequently, no purification was attempted.

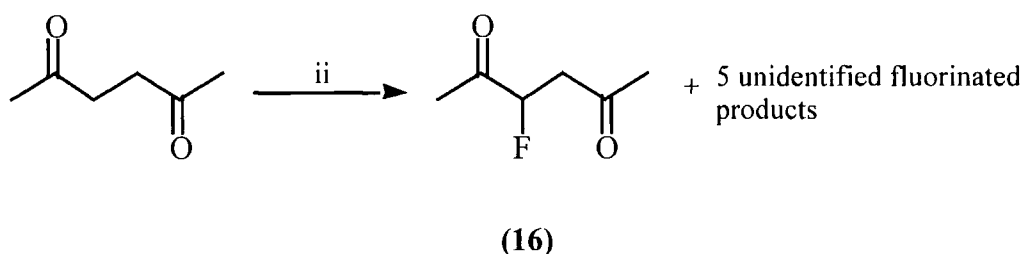

48% conv., 78% yield (compounds in crude products)

i=10% F_2/N_2 , CH_3CN , 0°C , 18h.

Scheme 2.22

The conversion is much lower than the one observed when Selectfluor™ is used. Nevertheless some fluorination occurred next to the carbonyl which was not detected when we ran the fluorination of 2-heptanone (without catalyst). But the reaction is less selective (6 different products were formed). The ^{19}F NMR and GC-MS were not understood.

2.3.b. Cyclic ketones

2.3.b.i. Cyclopentanone

Fluorination of cyclopentanone was also carried out by passing fluorine through a solution of cyclopentanone and acetonitrile. The ^{19}F NMR of the crude product obtained after work-up allowed us to identify the 2-fluoro-cyclopentanone (**18**) (compared to previous identification), 3-fluoro-cyclopentanone as well as a difluorinated product in the ratio 1:2.5:2. Several purifications by column chromatography failed.

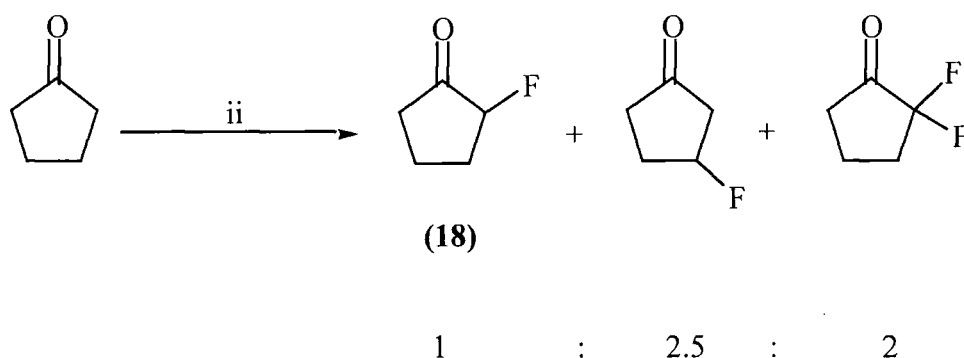

38% conv., 99% yield

i=10% F_2/N_2 , CH_3CN , 0°C , 18h.

Scheme 2.23

The presence of a triplet at $\delta_{\text{F}}=-70.59\text{ppm}$ is consistent¹⁰⁰ with a CF_2 . The only possibility to get a triplet would be that fluorines were next to the carbonyl. The fluorine signal at $\delta_{\text{F}}=-176.93\text{ppm}$ is consistent with a monofluorinated derivative which can be nothing else but 3-fluoro-cyclopentanone. We have detected the α -fluoro derivative by ^{19}F NMR. It seems that the enolization was favoured in the case of cyclic compounds (enol more stable in cyclic systems) whereas none occurred when acyclic ketones were used. The fluorination was major at C-3 because this site is further away from the ewg.

2.3.b.ii. Cyclohexanone

The fluorination of cyclohexanone using fluorine was performed using the same methodology. The crude product isolated after the usual work-up was analyzed by ^{19}F NMR and contained a mixture of 2-, 3- and 4-fluoro-cyclohexanone in the ratio 1:3.7:10. Purification by column chromatography using 2:1 hexane/ethyl acetate allowed us to isolate 2- and 3-fluoro-cyclohexanone as a mixture of isomers. But none of the major derivative, 4-fluoro-cyclohexanone was recovered.

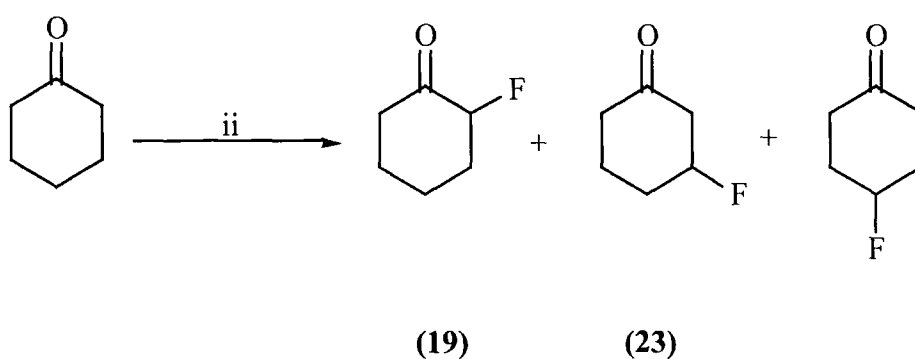

26% conv.

i=10% F_2/N_2 , CH_3CN , 0°C , 18h.

Scheme 2.24

2-Fluoro-cyclohexanone was identified by comparison with a previous experiment. 3-Fluoro-cyclohexanone was determined from the ^{13}C NMR. The carbon next to the carbonyl was detected by ^{13}C NMR at $\delta_{\text{C}}=31\text{ppm}$ (correct region for a CH_2 next to carbonyl) as a doublet with a coupling constant of 21Hz (a two-bond carbon-fluorine coupling). The products distribution could be explained by the fact that the fluorination tends to take place further away from the ewg that is why the ratio is the following 2-F<3-F<4-F.

2.3.b.iii. Cycloheptanone

Direct fluorination of cycloheptanone was carried out using the same protocol. The crude product remaining after work-up contained a mixture of 2-, 3- and 4-fluoro-cycloheptanone in the ratio 1:1.4:3.2. A purification by column chromatography using 3:1 hexane/ethyl acetate was performed and gave a mixture of 3- and 4-cycloheptanone.

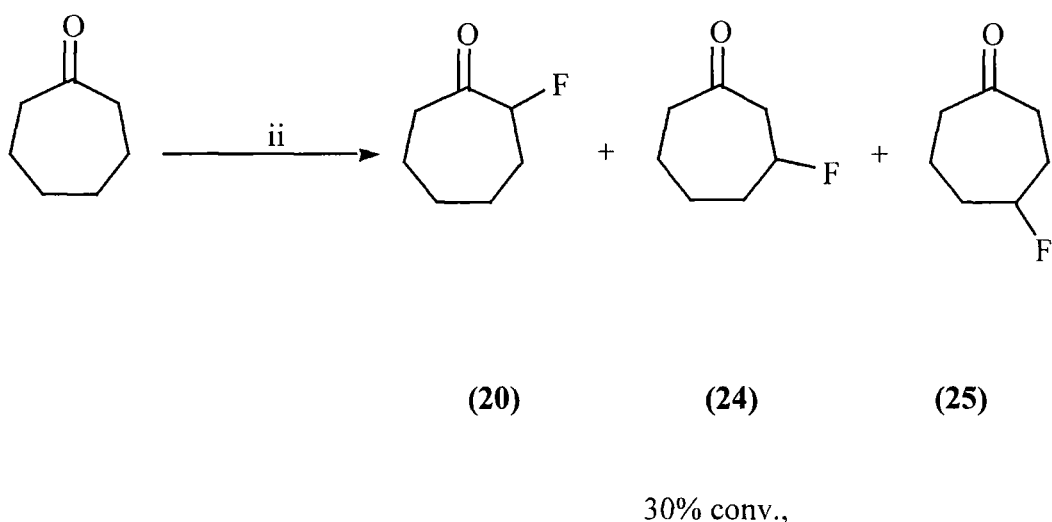

ii=10% F₂/N₂, CH₃CN, 0°C, 18h.

Scheme 2.25

The 2-fluoro-cycloheptanone was detected on the ¹⁹F NMR. The two other isomers were mainly identified from the ¹³C NMR. A three-bond coupling constant (³J_{CF}=8.6Hz) was found between the carbonyl (δ_C=209.4ppm) and fluorine which is consistent with the 3-fluoro-cycloheptanone. The third fluorinated derivative could only be the 4-fluoro-cycloheptanone.

Here again, the product distribution was explained by the fact that fluorination occurred at C-4 mainly (further away from carbonyl) then C-3 and C-2. As the other cyclic systems, the enolization was favoured as well using these reaction conditions.

2.3.c. Mechanism

The formation of the α -fluoroketone in the case of the cyclic ketones can be explained by a similar mechanism to the one postulated when Selectfluor™ was used. The enolization of the carbonyl would be promoted, using these reaction conditions, giving rise to the enol derivative. Then a concerted cyclic mechanism would follow to lead to the α -fluoroketone.

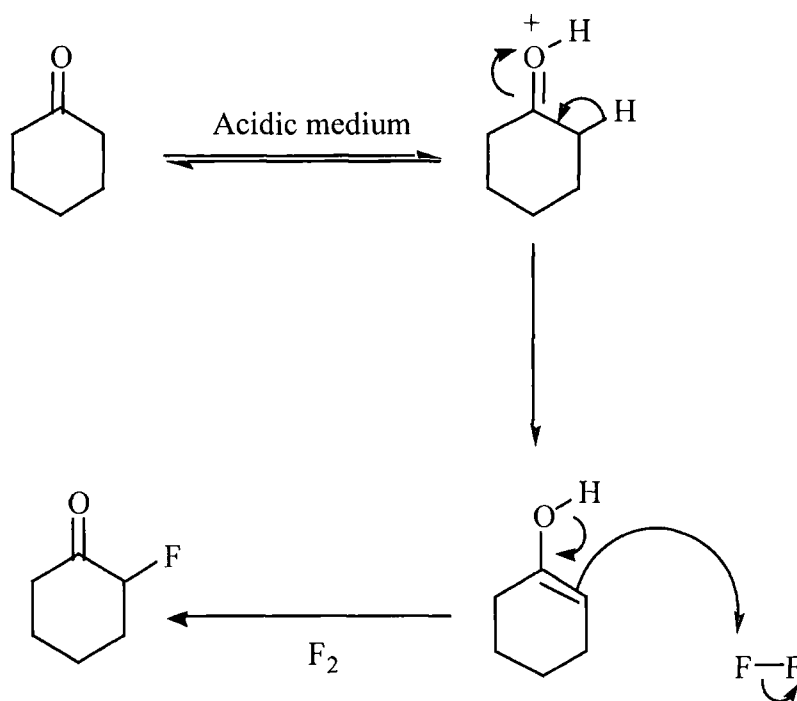

Scheme 2.26

The formation of other derivative can be explained by an electrophilic substitution as follows.

Chapter Three: Fluorination of Aldehydes

3.1. Introduction

In Chapter Two it has been shown that the fluorination of various acyclic and cyclic ketones took place on the chain and at the alpha position of the carbonyl when Selectfluor™ was used. Given this result, the same methodology has been applied to a range of straight chain and aromatic aldehydes to compare the products observed by fluorination using fluorine or Selectfluor™.

3.2. Fluorination of Heptanal using Fluorine

Fluorination of heptanal was carried out by passing an excess of elemental fluorine, 10% (v:v) diluted in nitrogen, through a cool solution (0°C) of heptanal and dry acetonitrile. The ¹⁹F NMR of the solution showed the presence of heptanoyl fluoride ($\delta_F = +44.91$ ppm, compare to literature data¹⁰⁰) in 66% yield and minor impurities relative to fluorination of the chain. The yield of acyl fluoride observed was calculated by adding a known amount of reference (fluorobenzene) in the NMR tube. Because the acyl fluoride is an unstable species some 3,5-dinitrobenzyl alcohol was added to the reaction mixture in order to isolate an ester derivative proving that we had an acyl fluoride intermediate. The 3,5-dinitrobenzyl alcohol was chosen due to its big size and the ease of the nucleophilic displacement. The crude product obtained after work up contained a major compound on the GC (84% yield). The (3,5-dinitrophenyl)methyl heptanoate (**26**) was isolated by column chromatography and identified by comparison with an authentic sample.

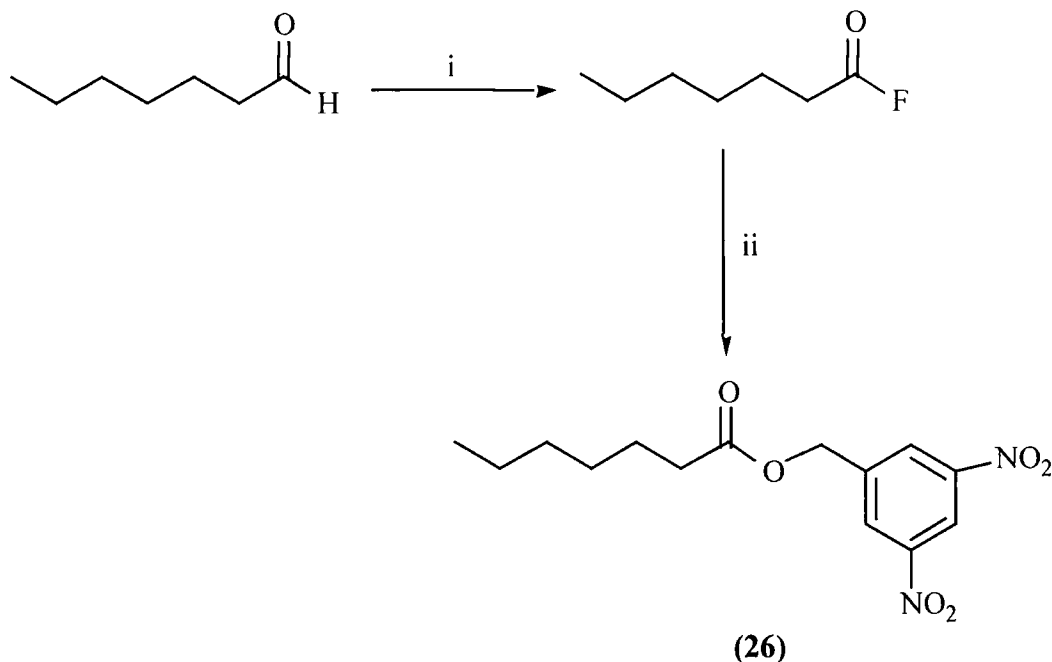

100% conv., 43% isolated yield

i=10% F₂/N₂, CH₃CN, 0°C, 18h.

ii= 3,5-dinitrobenzyl alcohol, CH₃CN, 82°C, 20h.

Scheme 3.1

The ¹³C NMR allowed us to identify the carbonyl of the ester functionality with a chemical shift found at δ_C=173ppm. The carbons of the aromatic ring were identified between 118 and 149ppm. The aromatic protons were detected in the expected area as well (δ_H=8.5 and 9ppm).

3.3. Mechanism

3.3.a. Fluorination

Elemental fluorine adds to the carbonyl function then dehydrofluorination gives rise to the acyl fluoride as shown below.

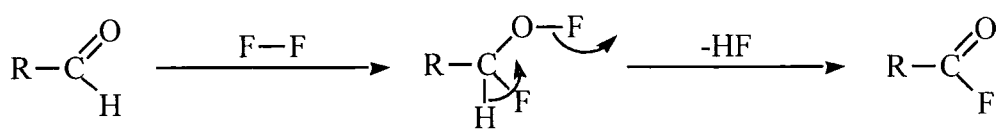

Scheme 3.2

3.3.b. Nucleophilic displacement

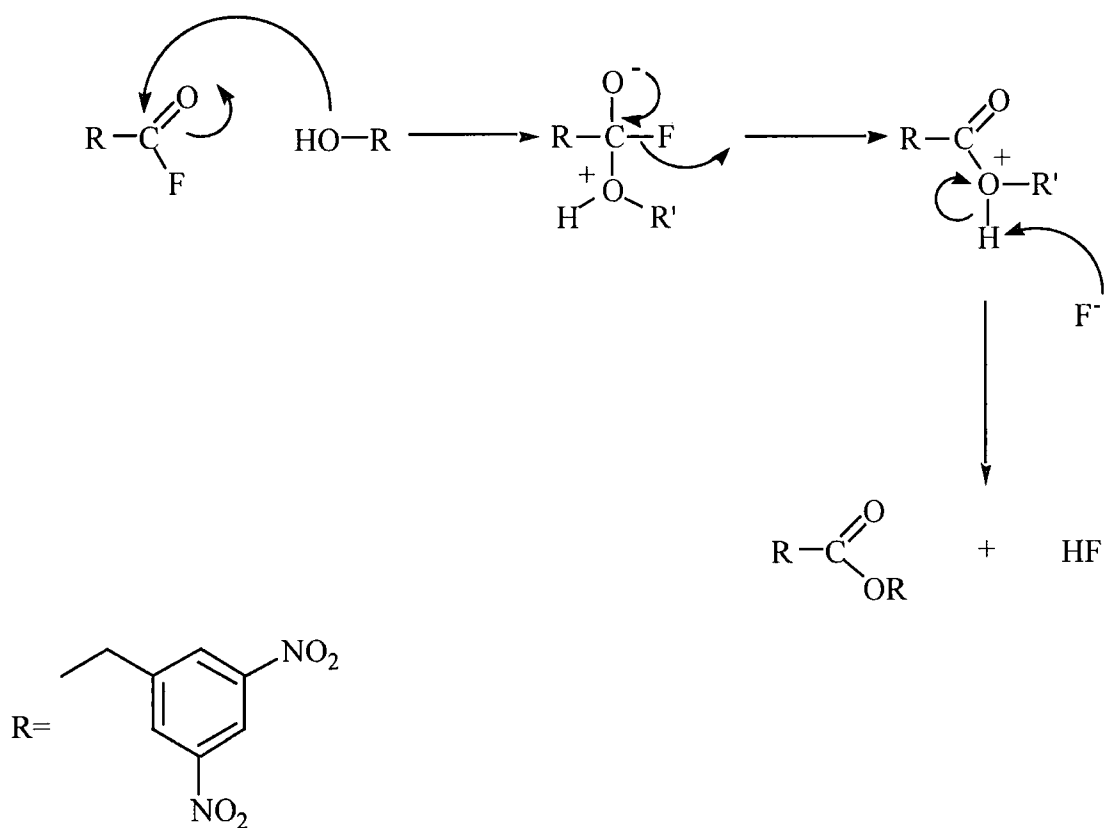

Scheme 3.3

A C-F bond is very strong to break and it is more likely that the nucleophilic displacement occurs following an addition-elimination process as shown above (Scheme 3.3).

The 3,5-dinitrobenzyl alcohol adds to the carbonyl group followed by elimination of fluoride ion. Then, deprotonation of the oxygen gives rise to HF by combination with F⁻.

3.4. Fluorination of Heptanal using Selectfluor™

Fluorination of heptanal using Selectfluor™ was carried out by heating a solution containing a small excess of Selectfluor™ and heptanal in acetonitrile during 3 days. The aqueous work-up gave a crude product containing 6 unidentified fluorinated products in the ratio 4.2:2:3.9:1:7.4:6.6. No trace of acyl fluoride was detected at all on the ¹⁹F NMR. No purification was done.

3.5. Fluorination of Decanal

The direct fluorination of decanal was achieved by passing fluorine through a cool solution (0°C) of decanal and acetonitrile. The ¹⁹F NMR of the reaction mixture showed the presence of acyl fluoride in 70% yield ($\delta_F = +44.92$ ppm) and minor impurities. Again, the yield of acyl fluoride was evaluated by ¹⁹F NMR using a known amount of reference (same as previous experiment). The second step of the reaction was performed by adding some 3,5-dinitrobenzyl alcohol. The crude product obtained after work-up contained (3,5-dinitrophenyl)methyl decanoate (**27**).

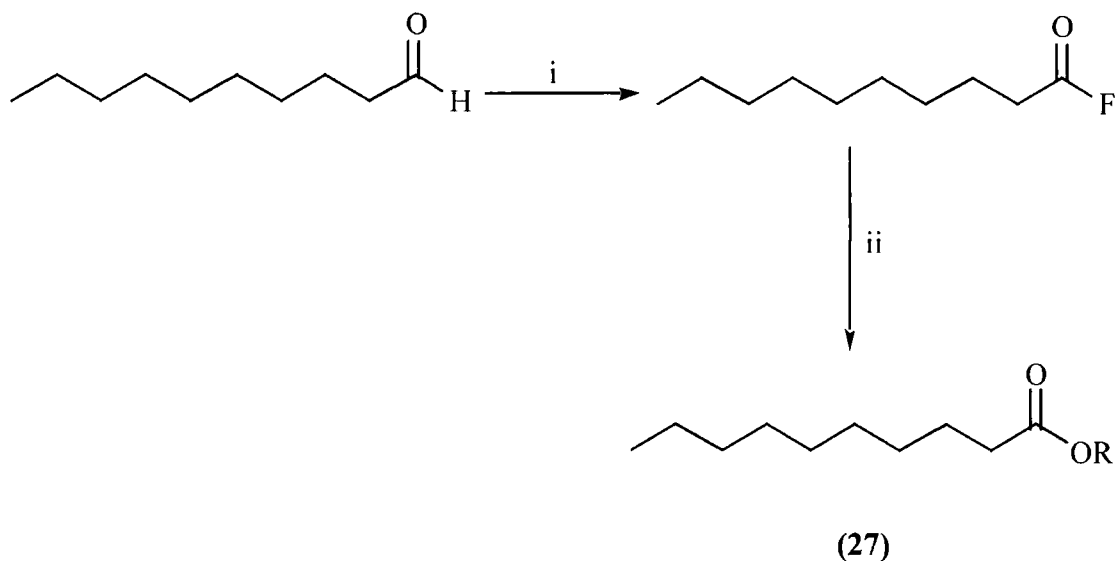

100% conv., 55% isolated yield

i=10% F₂/N₂, CH₃CN, 0°C, 18h.

ii= 3,5-dinitrobenzyl alcohol, CH₃CN, 82°C, 20h.

Scheme 3.4

The structure of this compound was proved by ¹³C and ¹H NMR. The presence of the carbonyl of the ester function was detected on the ¹³C NMR at δ_C=173.4ppm. The aromatic carbons were found between 118 and 149ppm and the aromatic protons at δ_H=8.5 and 9ppm.

It has been found that the fluorination reaction led to substitution of the aldehydic hydrogen and not of the chain. The process follows a two step reaction. First of all, the addition of the fluorine to the carbonyl gives rise to an acyl fluoride which is hydrolytically unstable. This step is followed by an addition-elimination of 3,5-dinitrobenzyl alcohol leading to a stable ester derivative. For comparison we also studied the fluorination of aromatic aldehydes to see where the fluorination would occur.

3.6. Fluorination of Benzaldehyde

The direct fluorination of benzaldehyde was carried out following the same procedure. Despite a low amount of acyl fluoride (<1%) detected on the ^{19}F NMR at $\delta_{\text{F}}=+17.88\text{ppm}$, the second step was performed (trapping the acyl fluoride). After the usual work-up the crude product contained the *ortho*-, *meta*- and *para*-fluorobenzaldehyde in the ratio 4.3:8.2:1 (Scheme 3.5). In addition, the ester derivative was detected on the GC-MS (1.5% area on GC). These three derivatives have been identified by comparing their ^{19}F NMR chemical shifts with the literature data⁹⁹.

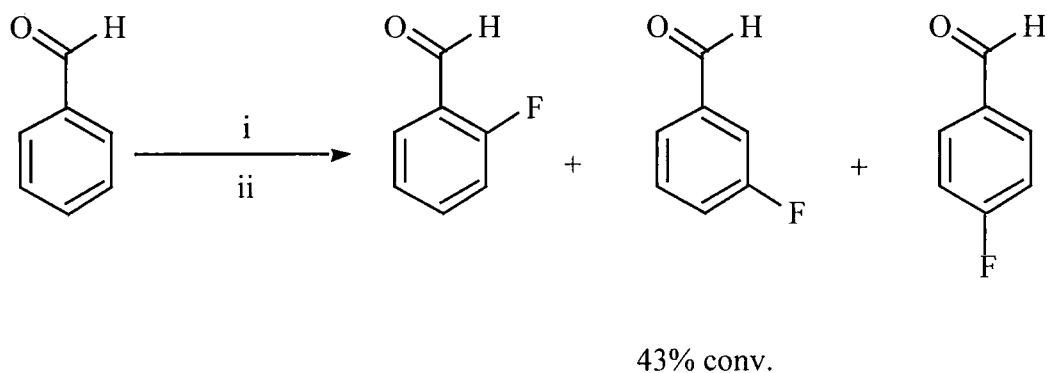

i=10% F_2/N_2 , CH_3CN , 0°C , 18h.

ii= 3,5-dinitrobenzyl alcohol, CH_3CN , 82°C , 3d.

Scheme 3.5

The conversion is lower than for straight chain aldehydes and the fluorination took place mainly on the ring. The ratio of the products is *meta*>*ortho*, *para* which is consistent with the electrophilic substitution of an aromatic derivative bearing an electron withdrawing group.

The electron withdrawing group (ewg) increases the positive charge on the ring and consequently destabilizes it. Considering the inductive effect of the ewg on σ -complex, it has been seen that the *ortho* and *para* complexes have a positive charge at the

carbon bearing the ewg which is not the case for the *meta* complex. Therefore any -M or -I groups by removing electron density destabilizes the three complexes but mostly the *ortho* and *para*. Consequently an ewg is deactivating and *meta*-directing as well.

3.7. Fluorination of Trifluoromethyl-*para*- Tolualdehyde

The direct fluorination of trifluoromethyl-*para*-tolualdehyde was carried out by passing an excess of diluted fluorine in nitrogen 10% (v:v) through a solution of trifluoromethyl-*para*-tolualdehyde and acetonitrile. After having detected 50% of acyl fluoride and two other monofluorinated derivatives (50%) in the reaction mixture, 3,5-dinitrobenzyl alcohol was added to the solution and heated up for one day. The usual aqueous work-up gave rise to a crude product containing (3,5-dinitrophenyl)methyl 4-(trifluoromethyl)benzoate (**28**) and two fluorinated derivatives in the ratio 1:1 which were not isolated because they were present in a too small amount.

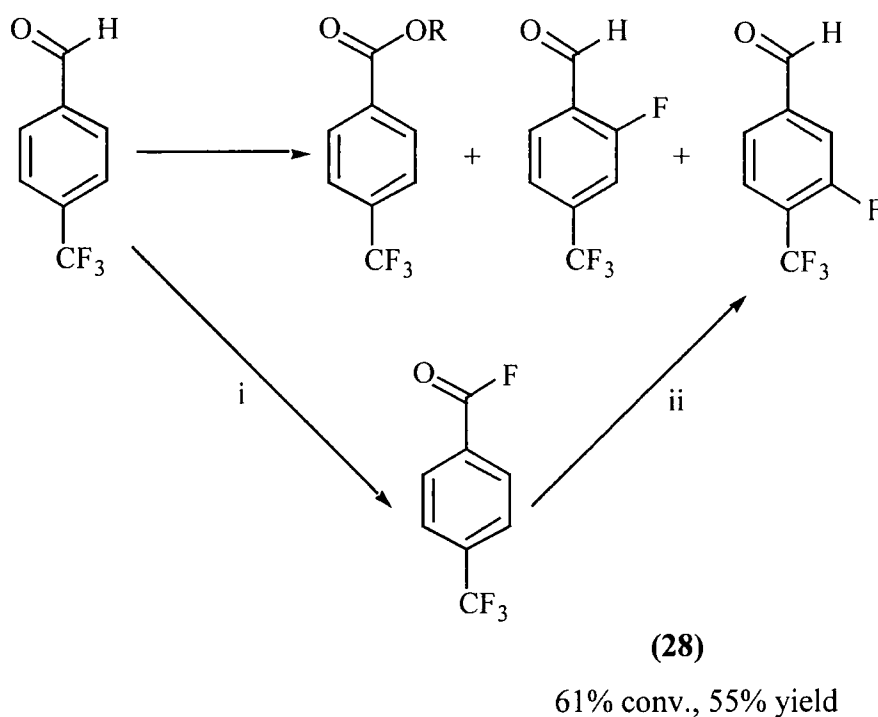

i=10% F₂/N₂, CH₃CN, 0°C, 18h.

ii= 3,5-dinitrobenzyl alcohol, CH₃CN, 82°C, 1d.

Scheme 3.6

The structure of the two fluorinated derivatives has been found using the coupling constants between F and aromatic protons.

- First derivative

2-fluoro-trifluoromethyl-*para*-tolualdehyde

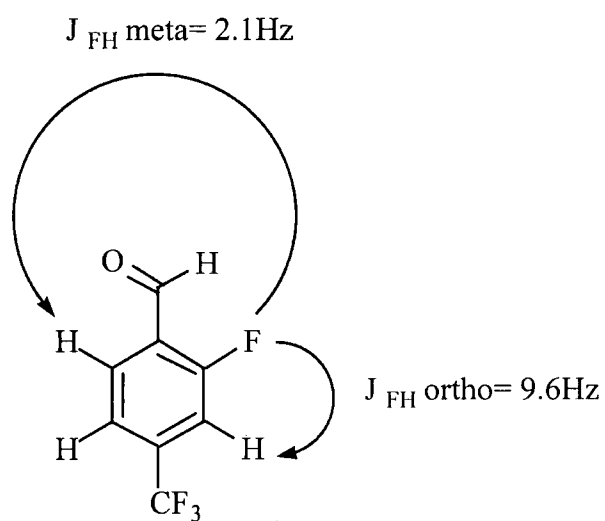

$\delta_F = -120.26\text{ppm}$ (C-F, dd)

$\delta_F = -63.69\text{ppm}$ (CF₃, s)

Scheme 3.7

- Second derivative

3-fluoro-trifluoromethyl-*para*-tolualdehyde

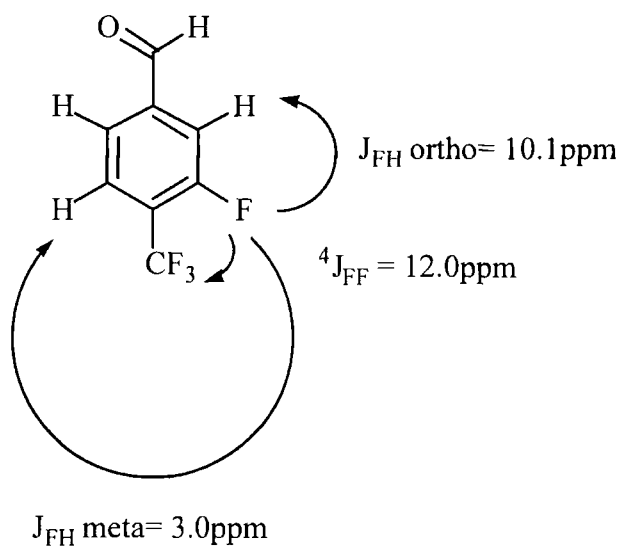

$\delta_F = -114.23\text{ ppm}$ (C-F, dd)

$\delta_F = -62.67\text{ ppm}$ (CF₃, d)

Scheme 3.8

The ring is too deactivated by the presence of two electron withdrawing groups (ewg) and consequently the fluorination takes place on the carbonyl mainly.

Our last fluorination reaction was done with an aromatic aldehyde containing an electron donating group (edg) to compare.

3.8. Fluorination of *para*-Tolualdehyde

Fluorination of *para*-tolualdehyde gave only <1% of acyl fluoride. Consequently, we worked the reaction up straight afterwards. The crude product contained only 3-fluoro-*para*-tolualdehyde detected by ^{19}F NMR, compared to literature data¹⁰⁰.

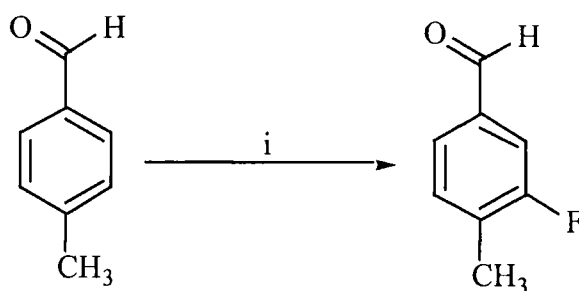

64% conv.

i=10% F₂/N₂, CH₃CN, 0°C, 18h.

Scheme 3.9

This result is consistent with aromatic electrophilic substitution. The methyl group (+I) should activate the substitution at the *ortho* and *para* position (*para* is occupied by the aldehyde function). The aldehyde should be *meta*-orientating because of its -I effect.

3.9. Mechanism

3.9.a. Fluorination

Depending on the nature (ewg or edg) of the group attached to the benzaldehyde ring, the fluorination will take place either on the ring or the fluorine will replace the aldehydic proton. This is due to the electronic effect coming from the ewg or edg. We have shown earlier that the fluorination occurred on the aromatic ring (Scheme 3.9) when

the *para*-tolualdehyde (electron rich) was used whereas the fluorination of the trifluoromethyl-*para*-tolualdehyde (electron deficient) led to the ester derivative. The same mechanism can be postulated for the formation of the acyl fluoride (Scheme 3.10).

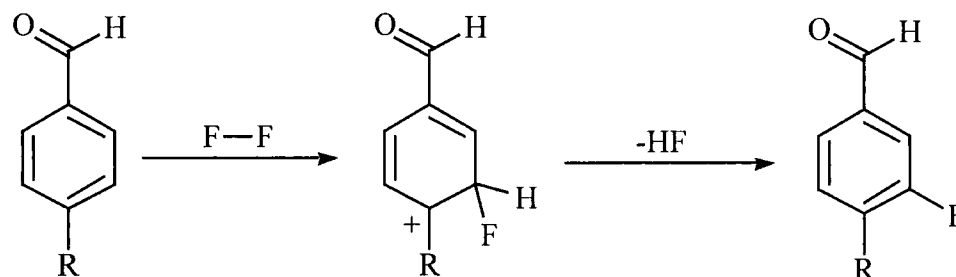

R=edg, H.

Scheme 3.10

When R=CH₃ it has been shown that fluorine added to the *meta* position (towards CHO) as seen above. The positive charge present in the sigma complex is stabilized by the positive inductive effect of the methyl group.

When R=H we have seen earlier that the fluorination of benzaldehyde occurred at the *ortho*, *para* and *meta* position with a preference for the meta one due to known electronic effects.

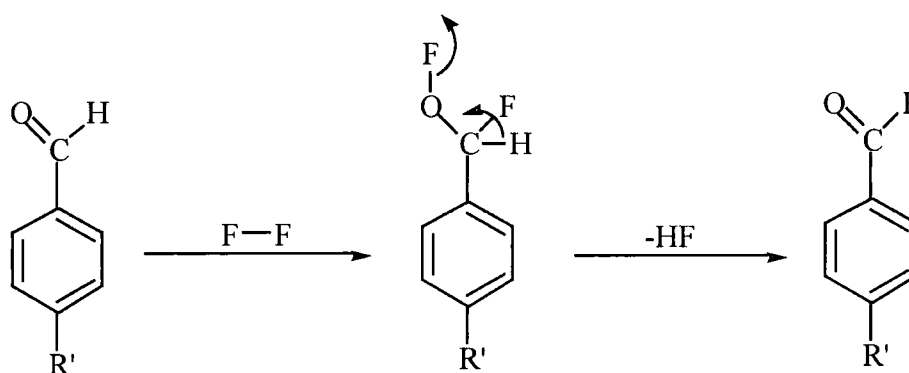

R'=EWG.

Scheme 3.11

Again, the fluorine adds to the carbonyl to give the acyl fluoride after dehydrofluorination.

3.9.b. Nucleophilic displacement

The addition of 3,5-dinitrobenzyl alcohol after direct fluorination led to the formation of a stable ester derivative when trifluoromethyl-*para*-tolualdehyde was used. This occurs following the same addition-elimination process seen in the section 3.3.b.

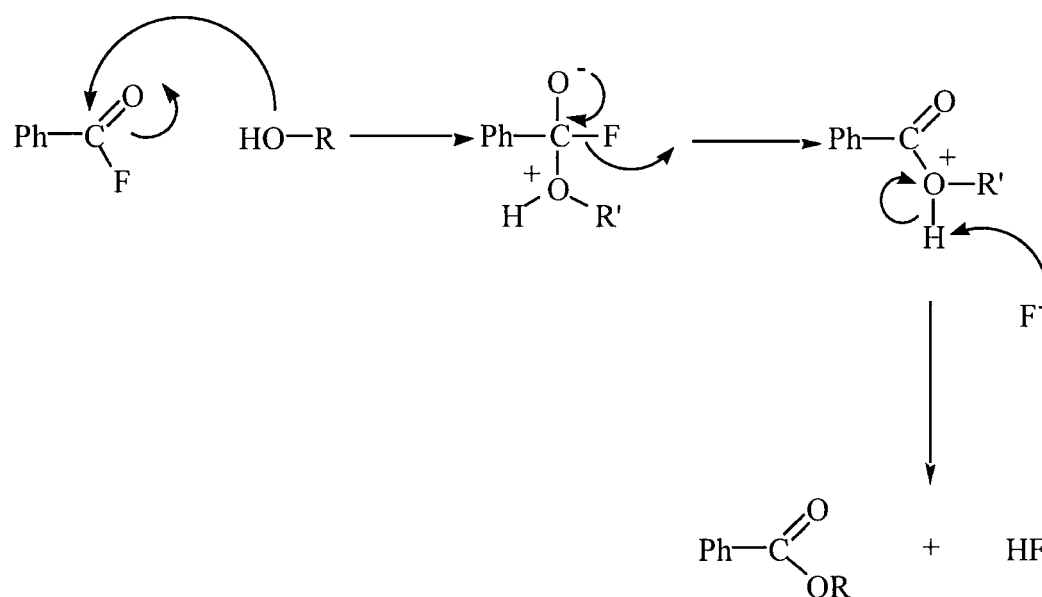

Scheme 3.12

The addition of the 3,5-dinitrobenzyl alcohol followed by elimination of HF gives rise to the ester derivative.

3.10. Conclusion

A range of aldehydes (aliphatic and aromatic) has been fluorinated using fluorine to give rise to their respective acyl fluorides. These compounds are hydrolytically unstable and cannot be purified straight away. So, we had to trap them using 3,5-dinitrobenzyl alcohol to get a stable ester derivative.

This methodology worked very well with straight chain aldehydes in high conversion. Concerning the aromatic aldehydes we have observed that the fluorination occurred in lower conversion because the aromatic species are less electron rich.

It has been noticed that the fluorination took place on the ring when bearing an electron donating group (*para*-tolualdehyde) whereas it replaces the aldehydic proton first when the ring contains an electron withdrawing group (trifluoromethyl-*para*-tolualdehyde). This has been explained using the stability and electron density of the aromatic ring. *para*-Tolualdehyde is richer than benzaldehyde itself so the fluorination occurred on the ring. Concerning the trifluoromethyl-*para*-tolualdehyde, the aromatic was too deactivated. This is the reason why fluorine added to the carbonyl first.

Fluorination of aldehydes was attempted using Selectfluor™ as well. But the results were very messy, the conversion low. Therefore, we did not push them further.

Chapter Four: Fluorination of Nitriles

4.1. Introduction

As the last part of our studies on the fluorination of hydrocarbon systems containing an electron withdrawing group (ewg), we investigate the fluorination of nitriles using both elemental fluorine and. This methodology has been applied to aldehydes and ketones presenting a different regioselectivity for each. The fluorination of aldehydes took place on the carbonyl whereas the same process applied to ketones gave α -fluoro derivatives when was used and a mixture of isomers where fluorine was further away from the ewg when fluorine was used, as described in the previous chapters. We now discuss the effect of the cyano group on fluorination of various nitriles.

4.2. Fluorination of Nitriles using Selectfluor™

4.2.a. Heptanenitrile

The fluorination of heptanenitrile using was performed by heating a solution of heptanenitrile, a small excess of Selectfluor™ in acetonitrile overnight at reflux temperature. The aqueous work-up gave a crude product containing four monofluorinated derivatives identified as 6-, 5- and 7-fluoro-heptanenitrile in the ratio 10:3.4:1:1.2. The minor compound which could be either 3- or 4-fluoro-heptanenitrile (a doublet of multiplet with a $^2J_{FH}=48.9\text{Hz}$ was detected by ^{19}F NMR) was not recovered after purification. This one was achieved by column chromatography using 4:1 hexane/ethyl acetate. A mixture of isomers consisting of 5-, 6- and 7-fluoro-heptanenitrile ((**29**), (**30**) and (**31**)) was submitted to full characterisation and the results were consistent with the literature¹⁰⁰.

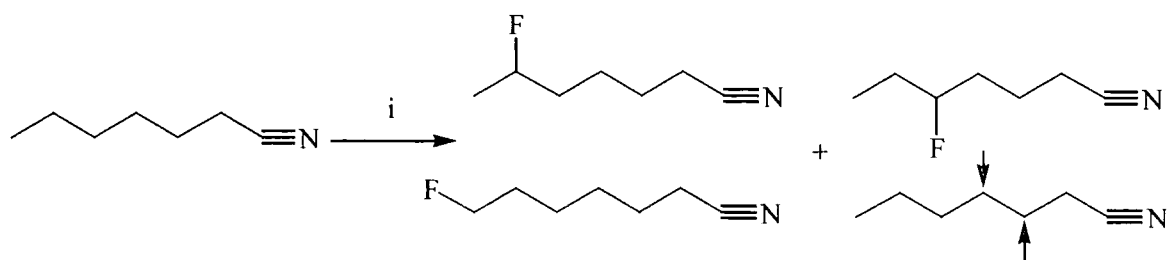

(29) : (30) : (31) : other derivative

10 : 3.4 : 1 : 1.2

9% conv.,

$i=1.1$ eq of Selectfluor™, MeCN, 82°C, 18h.

Scheme 4.1

The position of fluorine on the chain was determined using ^{13}C and ^{19}F NMR. In the case of 5-fluoro-heptanenitrile the ^{13}C NMR signal corresponding to the methyl ($\delta_{\text{C}}=9\text{ppm}$) was a doublet presenting a coupling constant of 6Hz with fluorine. This was consistent with a $^3J_{\text{CF}}$.

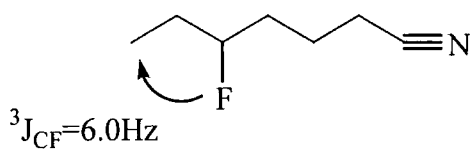

Scheme 4.2

Concerning the 6-fluoro-heptanenitrile, the methyl detected by ^{13}C NMR was a doublet ($\delta_{\text{C}}=20.8\text{ppm}$) with a coupling constant of 23Hz, typical of a $^2J_{\text{CF}}$.

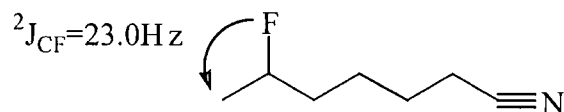

Scheme 4.3

The identity of the 7-fluoro-heptanenitrile was proved using ${}^{19}\text{F}$ NMR. The signal observed was a triplet located at $\delta_{\text{F}}=-219.10\text{ppm}$ corresponding to $\text{CH}_2\text{F}-\text{CH}_2$ ⁹⁹.

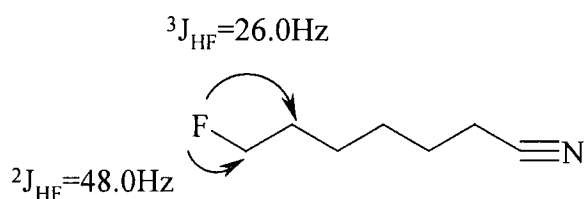

Scheme 4.4

In this case the fluorination tends to take place further away from the cyano group which is consistent with an electrophilic attack. The fluorination is not as specific as it was in the case of the ketones. As seen above, it occurred at different sites (both secondary and tertiary sites) but remote from the cyano function. This system seems to be too deactivated and only low conversion was observed under the reaction conditions used.

4.2.b. 1,5-Dicyanopentane

Fluorination of 1,5-dicyanopentane using SelectfluorTM was carried out following the same process as seen above for 5 days but no evidence of reaction was detected. The aqueous work-up gave a crude product from which the ${}^{19}\text{F}$ NMR suggests the presence of five fluorinated derivatives seen on the ${}^{19}\text{F}$ NMR in the ratio 1.4:1:5.5:12.3:11.7 but we were unable to detect those by GC.

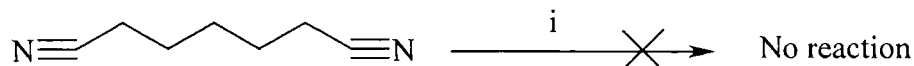

$i=1.1$ eq of SelectfluorTM, MeCN, 82°C, 18h.

Scheme 4.5

The system is even more deactivated in that case and less than 1% conversion was detected after 5 days. Therefore, no further investigation was carried out.

4.3. Fluorination of Nitriles using Elemental Fluorine

4.3.a. Octanenitrile

Direct fluorination of octanenitrile was performed by passing an excess of fluorine through a cooled solution (0°C) of octanenitrile and acetonitrile. The crude product, obtained after the usual work-up, contained 5-, 6- and 7-fluoro-octanenitrile ((**32**), (**33**) and (**34**)) in the ratio 13:1:6 respectively and minor impurities. Despite a low conversion (5% from NMR), purification by column chromatography using 4:1 hexane/ethyl acetate allowed us to isolate the three isomers as a mixture.

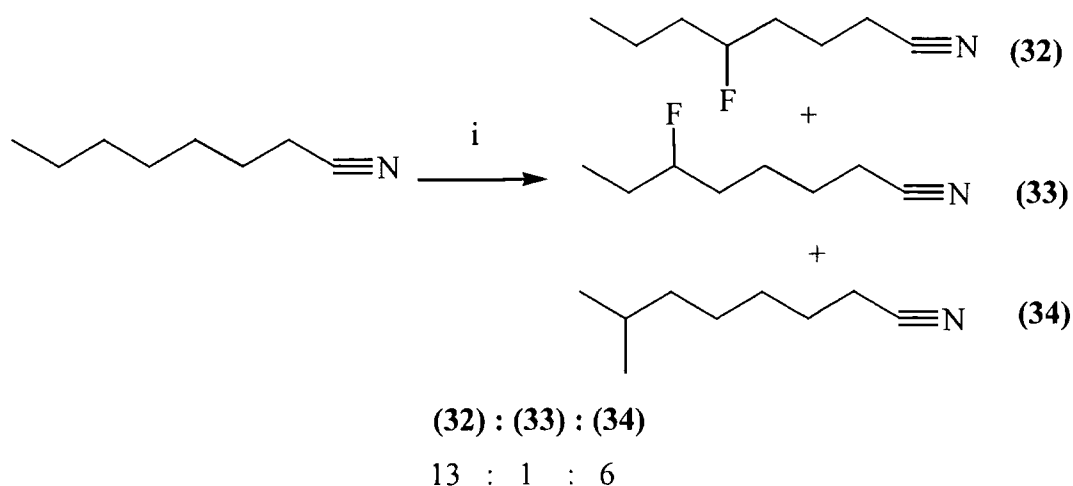

$i=10\%$ F₂/N₂, MeCN, 0°C, 18h.

Scheme 4.6

These compounds were identified using 1D and 2D NMR. It was more difficult to prove their structure as the NMR (^{19}F , ^{13}C and ^1H) were complicated and the coupling between the methyl and fluorine (6-fluoro-octanenitrile) did not appear.

The distribution products was not understood as the major compound (**32**) was the one having fluorine the closest to the cyano group.

4.3.b. Heptanenitrile

Fluorination of heptanenitrile using fluorine was carried out following the same methodology. The ^{19}F NMR of the crude product after work-up contained the same four products as those observed when the reaction was performed using SelectfluorTM. 5-, 6- and 7-fluoro-heptanenitrile (in the ratio 40:32:4:1 respectively) were identified by comparison with authentic samples.

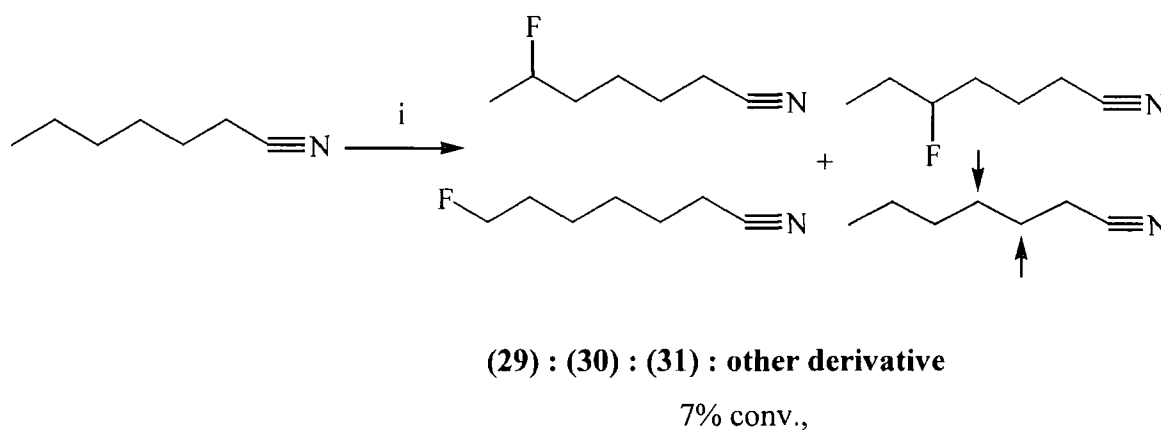

$i=10\% \text{ F}_2/\text{N}_2, \text{ MeCN}, 0^\circ\text{C}, 18\text{h}.$

Scheme 4.7

The results were very similar that those observed when SelectfluorTM was used. However, these systems are too deactivated towards electrophilic process and explained the very low conversion.

4.3.c. Other Systems

Fluorination of 1,5-dicyanopentane, isobutyronitrile and azelanitrile (NC-(CH₂)₇-CN) was attempted using the same methodology. But no further investigation was carried out as only 1% conversion was calculated from the ¹⁹F NMR.

4.4. Conclusion

We have observed that the fluorination using both Selectfluor™ and fluorine gave no useful product due to the very low conversion of the reactions.

Nevertheless we managed to isolate several isomers showing that fluorination occurred further away from the cyano group in both cases.

The relative distribution of isomers in these processes is neither consistent with an electrophilic attack nor radical attack because the latter would involve an electrophilic atom. In either case, we would anticipate preferential attack at the most remote secondary positions and we have noted that this was not the case.

It is possible that involvement of the cyano group occurs in directing the fluorination, either by an intramolecular or a bimolecular process but at this stage this is a speculation.

Chapter Five: Fluorination of Cyclic Ethers

5.1. Introduction

In Chapter II, III and IV we investigated the selective fluorination of hydrocarbon systems containing an electron withdrawing group (ewg). In general it was observed that the fluorination occurred at sites further away from the ewg, on the most electron rich C-H bond (Chapter II and IV). Given these results, we postulated that if an electron donating group was attached to an alkyl chain it would increase the electron density of the adjacent C-H bond. Therefore, we decided to study the selective fluorination of cyclic ethers as they are commercially available.

5.2. Fluorination of Ethers using Selectfluor™

5.2.a. Tetrahydrofuran

Fluorination of tetrahydrofuran using Selectfluor™ was carried out by heating a solution containing a small excess of Selectfluor™ and tetrahydrofuran in acetonitrile during 18h. The aqueous work-up gave a crude product containing 4 products detected by GC (57%, 13%, 18% and 11% area). The ¹⁹F NMR showed a mixture of peaks and corresponding to two isomers of 3-fluoro-2-(3-fluorooxolan-2-yloxy)oxolane (**35**) (100% conv., 35% isolated yield). These products were detected as the major peak on the GC. Only one isomer was isolated after purification by column chromatography using 2:1 hexane/ethyl acetate. The three other products were not isolated and could not be identified.

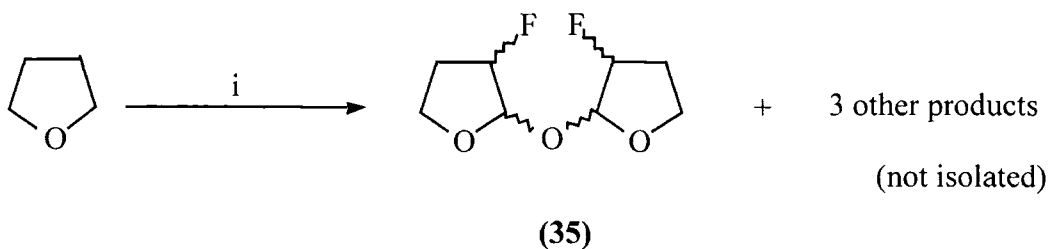

100% conv., 35% isolated yield ((35))

$i=1.1$ eq of SelectfluorTM, MeCN, 82°C, 18h.

Scheme 5.1

The retention time of the product was too high to be a simple monofluorinated ether derivative. The identity of the compound was determined using ^{19}F NMR ($\delta_{\text{F}}=-189.94\text{ppm}$) as well as ^{13}C and ^1H NMR. The molecule was determined to be completely symmetrical due to the fact that only 4 signals were detected on the ^{13}C and ^1H NMR. The position of the fluorine on the ring was determined from the ^{13}C and ^1H NMR as well (Scheme 5.2).

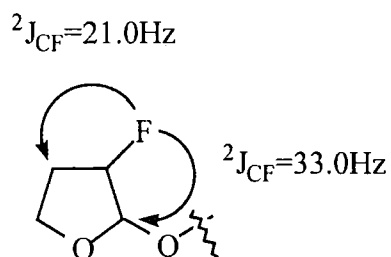

Scheme 5.2

The carbon adjacent to the oxygens, with a distinctive shift of $\delta_{\text{C}}=100.9\text{ppm}$ is coupled to the fluorine with a two bond coupling constant. Another two bond coupling constant was also observed between fluorine and the carbon far away from the ether function ($\delta_{\text{C}}=30.1\text{ppm}$) as shown above.

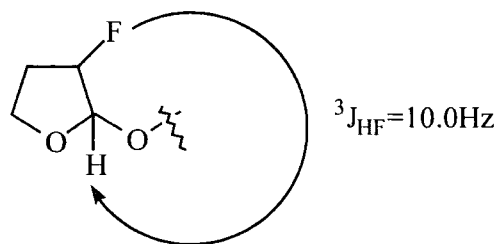

Scheme 5.3

A similar observation was seen on the ${}^1\text{H}$ NMR where the hydrogen attached to the carbon adjacent to the oxygens is coupled to fluorine through a three bond coupling constant as shown above (Scheme 5.3). The value of the coupling constant is small therefore F and H would be in cis position (one in equatorial and the other in axial).

The identity of this derivative was also consistent with electrospray mass spectrometry (chromatographic technique). Our compound was found to bind a sodium ion (MW=217g/mol= M^++Na^+). The cation coordinates with lone electron pair of the oxygens which means that there is affinity between the molecule and Na^+ (Scheme 5.4).

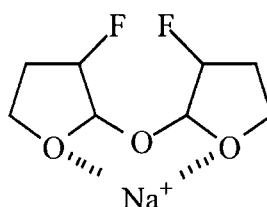

Scheme 5.4

5.2.a.i. Mechanism of Formation

The product resulting from the fluorination of tetrahydrofuran is unusual and unexpected. We can postulate a mechanism for the formation of 3-fluoro-2-(3-fluorooxolan-2-yloxy)oxolane (**35**) (Scheme 5.5) as shown below.

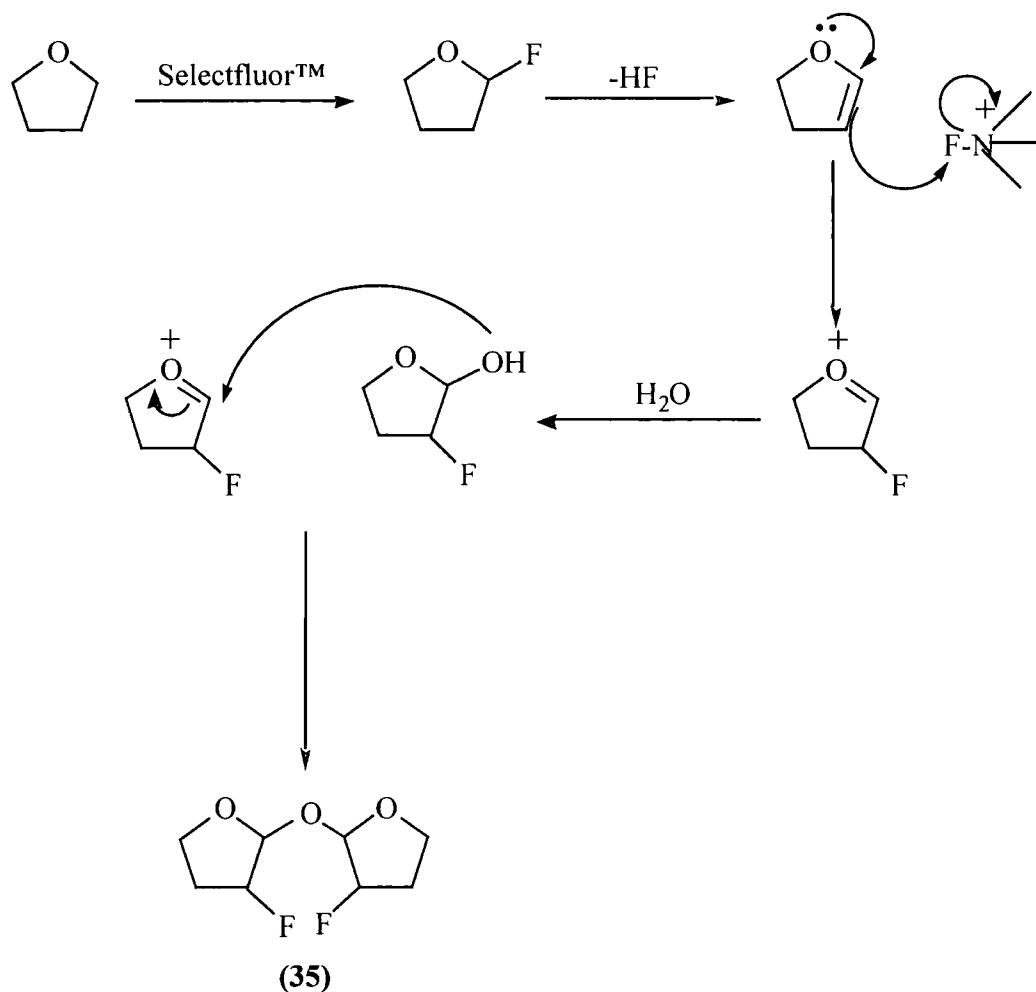

Scheme 5.5

First of all, fluorine should attack on the adjacent carbon to the oxygen because this carbon would give rise to the most stable carbocation due to the mesomeric effect of the oxygen. Next, a dehydrofluorination of the intermediate should lead to the formation of an alkene. The electron rich alkene will react with another molecule of Selectfluor™ to form the oxonium ion. This ion could be attacked by water during the work-up giving rise to an alcohol. This alcohol would react with another oxonium ion giving rise to 3-fluoro-2-(3-fluorooxolan-2-yloxy)oxolane (**35**).

5.2.b. Tetrahydropyran

Fluorination of tetrahydropyran using Selectfluor™ was performed following the same process. The crude product obtained after work-up was a mixture of two diastereoisomers of 3-fluoro-2-(3-fluoroperhydro-2H-pyran-2-yloxy)perhydro-2H-pyran (**36**) (100% conv., 40% isolated yield) in the ratio 1:1 from the GC. After purification by column chromatography using 2:1 hexane/ethyl acetate, only one isomer was recovered.

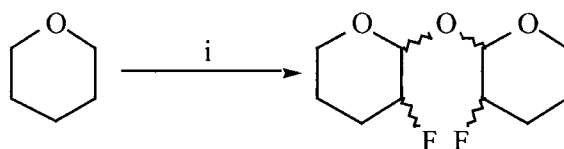

(36)

100% conv., 40% isolated yield

i=1.1 eq of Selectfluor™, MeCN, 82°C, 18h.

Scheme 5.6

The structure of this derivative was proved by using ^{13}C and ^1H NMR. The ^{19}F NMR chemical shift of this compound was very similar to the one concerning THF ($\delta_{\text{F}}=-190.33\text{ppm}$). The molecule was determined to be again completely symmetrical because 5 signals were detected on the ^{13}C and ^1H NMR.

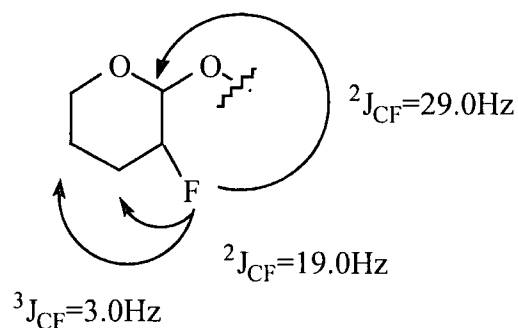

Scheme 5.7

The carbon adjacent to the oxygens is coupled to fluorine with a two bonds coupling constant of 29Hz. As well as C-3 (two bond) and C-4 (three bond coupling constant).

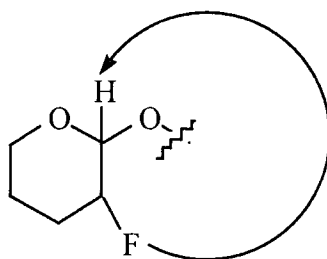

Scheme 5.8

The signal of the hydrogen was observed as a multiplet on ^1H NMR. We were not able to distinguish the three bonds coupling constant between fluorine and this hydrogen as the multiplet was not clear. We therefore cannot distinguish *trans* or *cis* coupling between H and F. The structure was also proved using electrospray (ES^+) which showed that the compound bound to sodium ion ($\text{MW}=245.1\text{g/mol}=\text{M}^++\text{Na}^+$) for the same reasons seen in section 5.2.a.

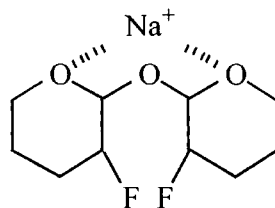

Scheme 5.9

5.2.c. 1,4-Dioxane

Fluorination of 1,4-dioxane using Selectfluor™ was carried out the same way as described previously. The crude product contained a compound detected at -141.7ppm by ^{19}F NMR which could be a difluorinated product (<1% conversion). The GC showed the presence of one compound (35%) and the starting material (65% area). A purification by column chromatography using 2:1 hexane/ethyl acetate gave rise to 2,5,7,10-tetraoxabicyclo[4.4.0]decane (**37**) (77% conv., 36% isolated yield). This compound was submitted to full characterisation.

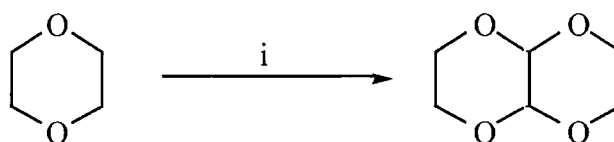

(37)

77% conv., 36% isolated yield

i=1.1 eq of Selectfluor™, MeCN, 82°C, 18h.

Scheme 5.10

The structure of this product was determined by ^{13}C and ^1H NMR in first place We also proved the identity of the compound by getting a crystal structure¹⁰² as seen in Scheme 5.11.

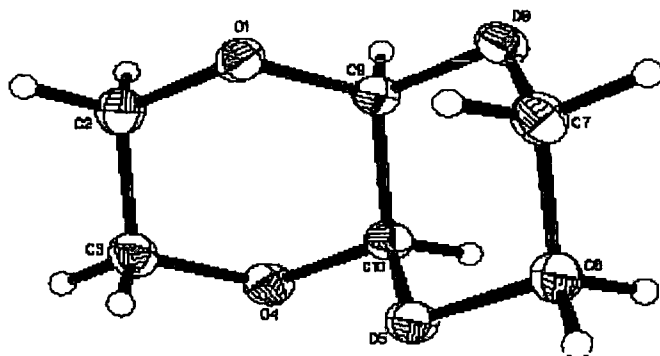

Scheme 5.11

5.2.c.i. Mechanism of Formation

The product resulting from the fluorination of 1,4-dioxane is even more unexpected. Two mechanisms can be suggested for the formation of the derivative observed.

- First mechanism

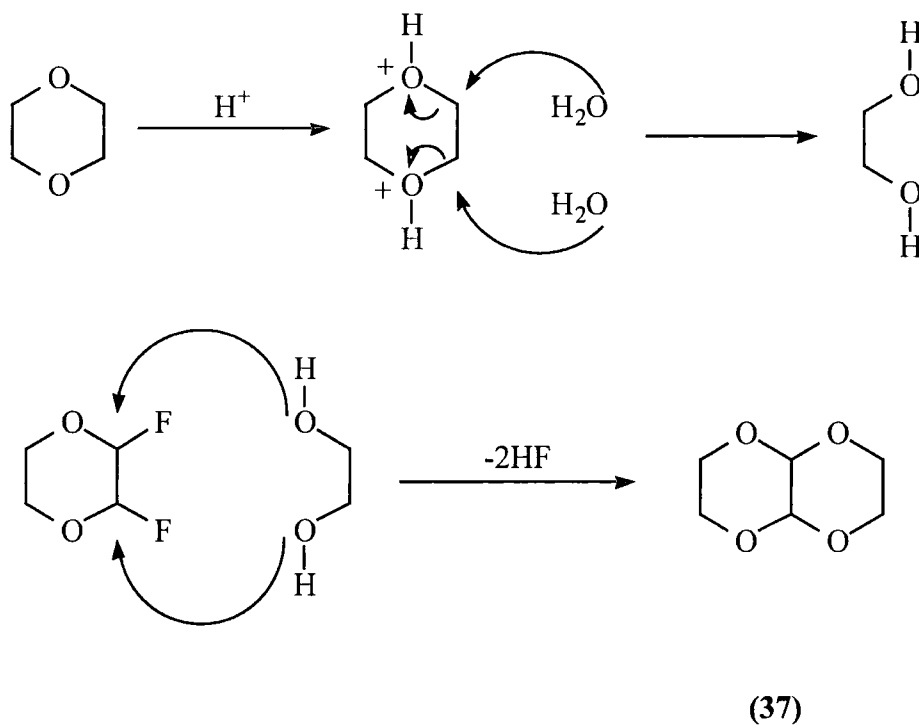

Scheme 5.12

1,4-Dioxane could be protonated in the first place (acidic reaction medium) and give rise to a diol. This one would react with a difluorinated dioxane (detected by ^{19}F NMR after work-up) to lead to 2,5,7,10-tetraoxabicyclo[4.4.0]decane (**37**) as seen above.

- Second mechanism

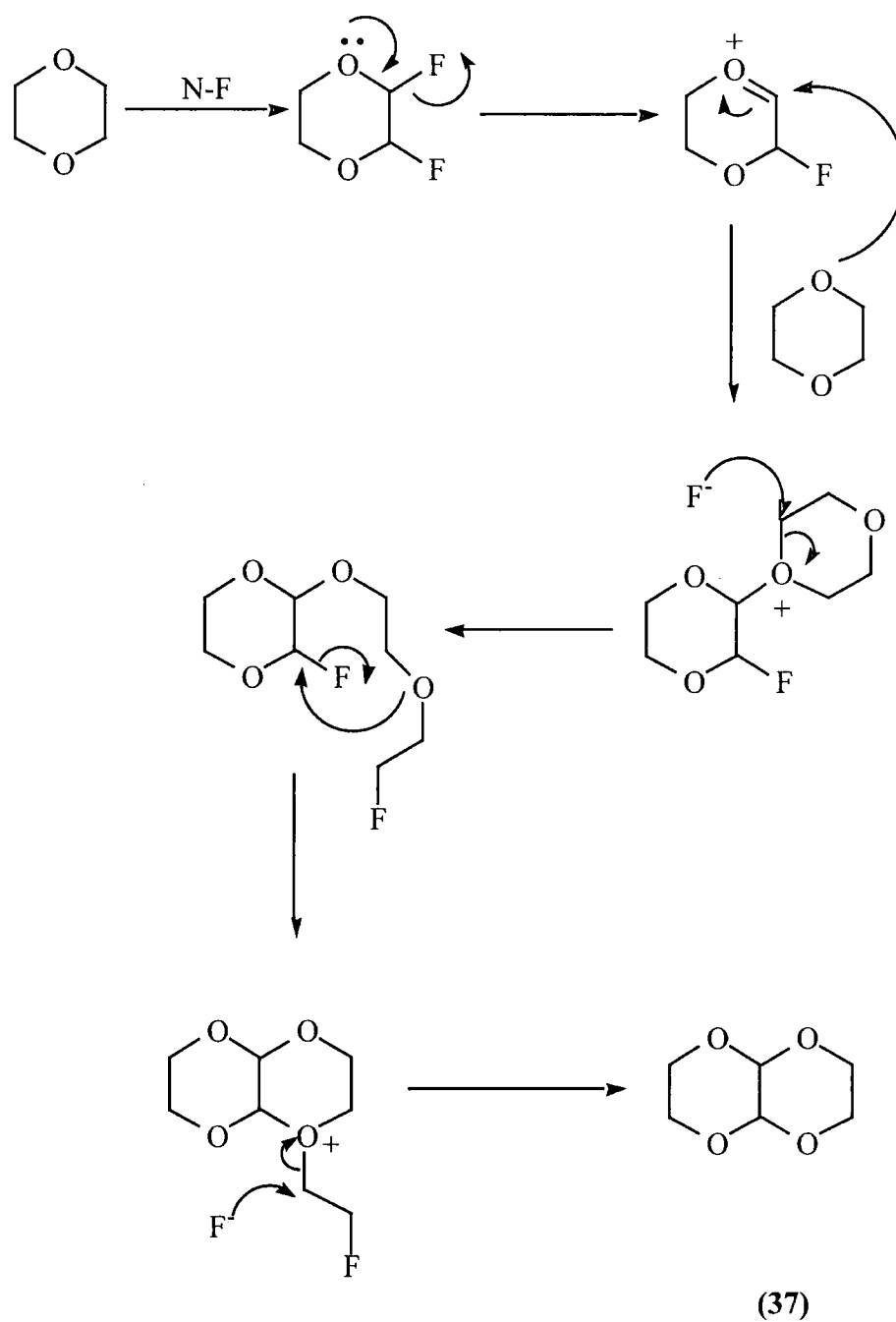

Scheme 5.13

1,4-Dioxane could be difluorinated and form an oxonium ion by loss of fluoride ion. Another 1,4-dioxane would stabilize the oxonium ion and react with fluoride ion and lead to ring opening. This is followed by nucleophilic displacement to lead to (37).

5.2.d. Hexamethylene oxide

The fluorination of hexamethylene oxide using Selectfluor™ was performed as usual. After work-up the crude product contained 2-fluoro-5-(3-fluorooxepan-2-yloxy)pentanal (**38**) (100% conv., 31% isolated yield) and another product in the ratio 4:1 from the GC. Purification by column chromatography using 3:1 hexane/ethyl acetate gave the major derivative but the other product could not be isolated.

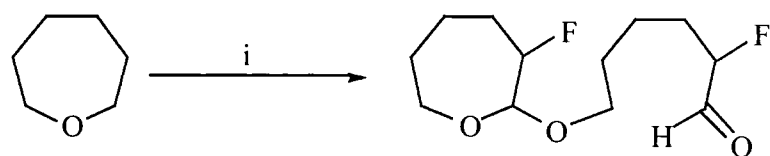

(38)

100% conv., 31% isolated yield

i=1.1 eq of Selectfluor™, MeCN, 82°C, 18h.

Scheme 5.14

The ^{13}C and ^1H NMR allowed us to identify the structure of this unusual derivative. The presence of a peak at $\delta_{\text{C}}=200.3\text{ppm}$ in the ^{13}C NMR indicated the presence of an aldehyde. The signal is a doublet with a coupling constant of 33Hz which is consistent with a two bond coupling constant between F and C. Therefore, one fluorine took place at the adjacent carbon to the carbonyl (Scheme 5.15).

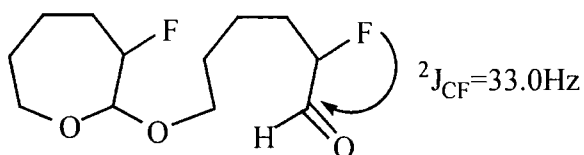

Scheme 5.15

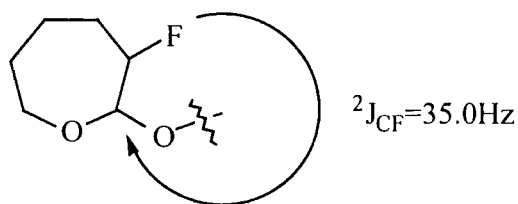

Scheme 5.16

The carbon bearing the two oxygens was detected at $\delta_C=104.3\text{ppm}$ by ^{13}C NMR as a doublet with a coupling constant of 35Hz typical from a two bonds coupling constant between C and F. The fluorine is therefore on the carbon adjacent to it (Scheme 5.13).

The aldehydic proton was detected by ^1H NMR at $\delta_H=9.77\text{ppm}$ (a doublet with a three bond fluorine-hydrogen coupling constant ${}^3J_{HF}=6.0\text{Hz}$).

The presence of two different signals ($\delta_F=-180.70$ and -200.18ppm) in the ratio 1:1 were observed on the ^{19}F NMR. This indicated that the molecule contained two fluorine atoms.

5.2.d.i. Mechanism

A possible mechanism for the formation of **(38)** is shown below (Scheme 5.17).

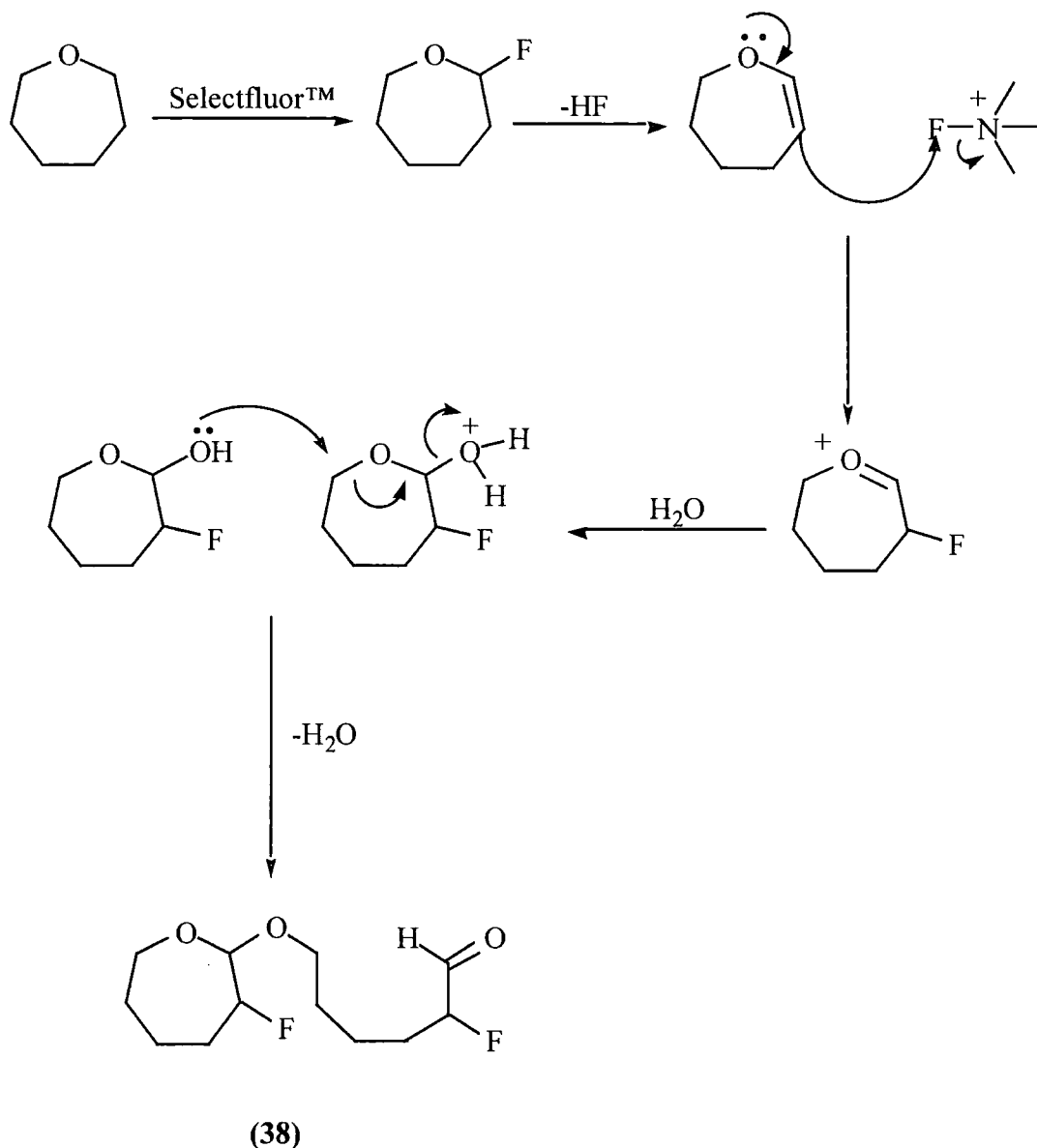

Scheme 5.17

The first three steps of formation of **(38)** could be explained the same way as seen in Section 5.2.a.i. It can be thought that a 7 membered ring oxonium ion is less stable than 6 and 5 ones. Therefore, all the molecules present in the solution would react with water to lead to the alcohol derivative. Finally, the alcohol could be protonated (acidic medium) and be attacked by another molecule of alcohol as observed in Scheme 5.17.

5.2.e. Other systems

Fluorination of 2-methyl-tetrahydrofuran using Selectfluor™ was carried out by heating at reflux temperature (82°C) a mixture containing 2-methyl-tetrahydrofuran, a small excess of Selectfluor™ and acetonitrile. After two days, only 3% conversion was observed and so no further investigation was carried out.

The fluorination of monoglyme using Selectfluor™ was attempted using monoglyme and Selectfluor™ in acetonitrile at reflux temperature but after 18h no reaction was detected.

The fluorination of 18-crown-6 using Selectfluor™ was also attempted using 18-crown-6 and Selectfluor™ in acetonitrile. The reaction was heated at reflux temperature but after 18h no reaction was detected either.

5.3. Fluorination using Elemental Fluorine

5.3.a. Tetrahydrofuran

The direct fluorination of tetrahydrofuran using elemental fluorine was performed by passing an excess of fluorine diluted in nitrogen (10% v:v) in a cooled (0°C) solution of tetrahydrofuran in acetonitrile. The crude product obtained after the aqueous work-up contained three compounds detected by GC (28%, 35% and 37% area). The major derivative was 3-fluoro-2-(3-fluorooxolan-2-yloxy)oxolane (**35**) as seen previously (section 5.2.1) (same chemical shift on ¹⁹F NMR spectrum and GC retention time). Several purifications by column chromatography were attempted but failed.

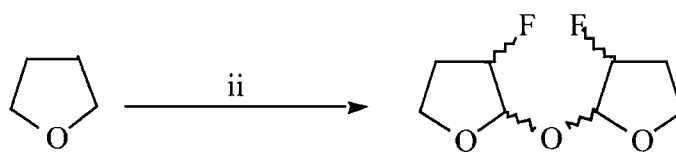

(35)

70% conv., 37% yield

i=4 eq 10% F₂/N₂, CH₃CN, 0°C.

Scheme 5.18

5.3.a.i. Mechanism

Two slightly different mechanisms can be postulated (Scheme 5.19 and 5.20).

- First mechanism

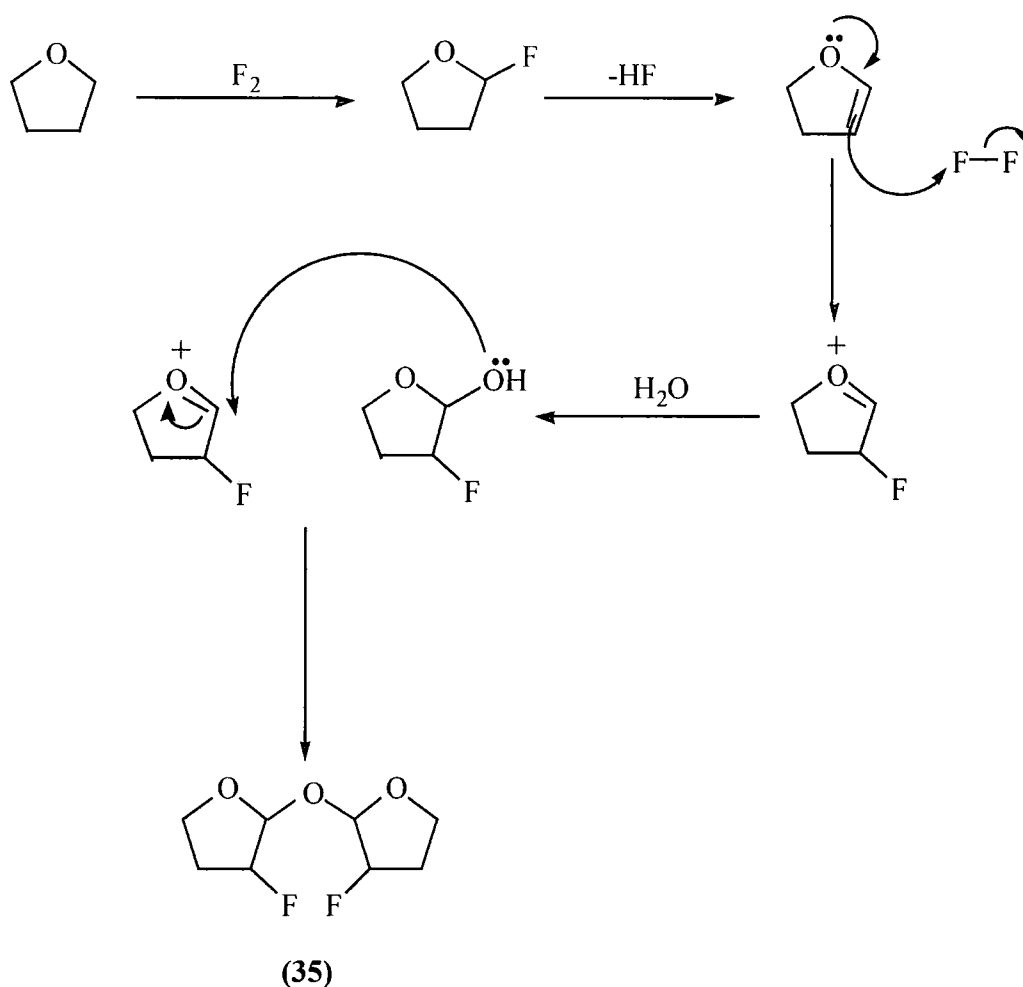

Scheme 5.19

The formation of the dimer is similar to the one described in Section 5.2.8.a. Fluorine attacks on the adjacent carbon to the oxygen to give a monofluorinated derivative. A dehydrofluorination should occur to give rise to an alkene. The electron rich alkene will react with another molecule of fluorine giving rise to an oxonium ion. Finally, an alcohol intermediate formed during the work-up would attack the oxonium and lead to **(35)**.

- Second mechanism

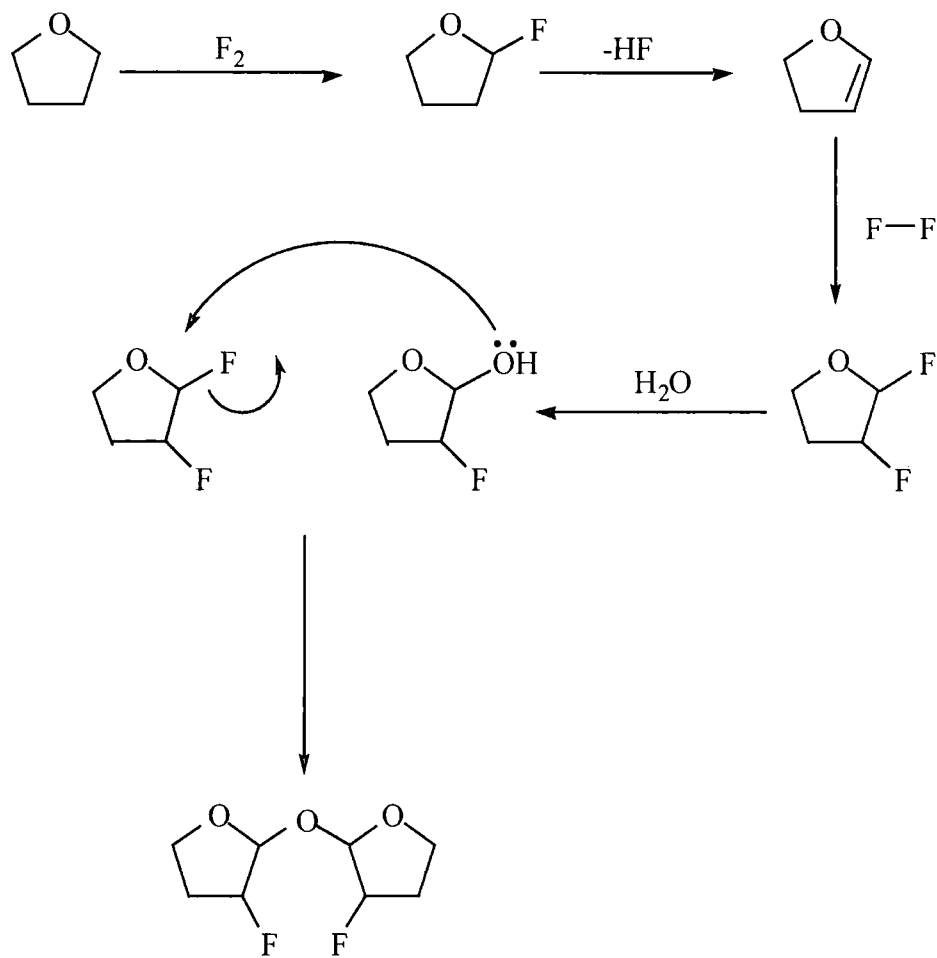

(35)

Scheme 5.20

The difference occurs after the dehydrofluorination. The alkene formed could be difluorinated as shown above. Because fluoride is a good leaving group, it could be replaced by a hydroxy group (due to the aqueous work-up). This hydroxy compound could replace a fluorine on a difluorinated compound present in solution. The same dimer would also be observed in that case.

5.3.b. Tetrahydropyran

Fluorination of tetrahydropyran using elemental fluorine was also carried out following the same conditions used for the direct fluorination of tetrahydrofuran. The crude product contained 4 fluorinated derivatives in the ratio 4:2.4:1.4:1. The 3-fluoro-2-(3-fluoroperhydro-2H-pyran-2-yloxy)perhydro-2H-pyran (**36**) seen previously (section 5.2.2) was detected as the major compound (same retention time and chemical shift on the ^{19}F NMR). Again, purifications by column chromatography or preparative GC failed.

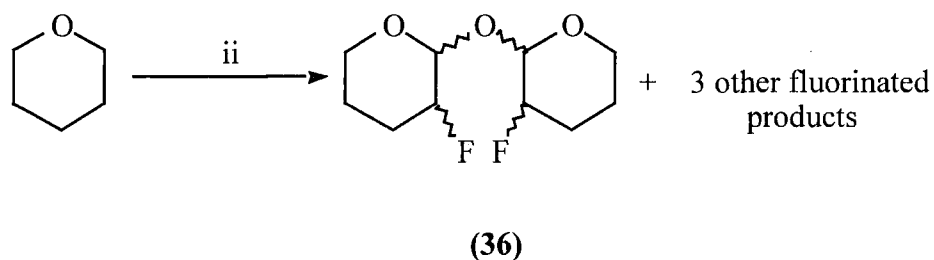

66% conv., 53% yield

i=4 eq 10% F_2/N_2 , CH_3CN , 0°C .

Scheme 5.21

5.3.c. 1,4-Dioxane

Fluorination of 1,4-dioxane was also carried out using elemental fluorine following the same process as seen previously. The crude product was a mixture of 4 fluorinated derivatives in the ratio 2:4:1:10 (which could not be identified) and 2,5,7,10-tetraoxabicyclo[4.4.0]decane (**37**) (60% conv., 25% yield) detected as the major derivative by GC.



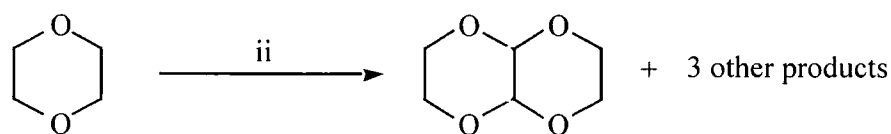

(37)

60% conv., 25% isolated yield

i=4 eq 10% F₂/N₂, CH₃CN, 0°C.

Scheme 5.22

5.3.d. Hexamethylene oxide

The direct fluorination of hexamethylene oxide was performed using elemental fluorine as well and gave a crude product containing an unidentified polymer. Only an elemental analysis was available.

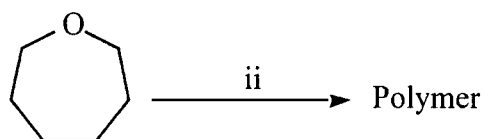

100% conv.

ii=4 eq 10% F₂/N₂, CH₃CN, 0°C.

Scheme 5.23

We did not find any suitable solvent to run the usual analysis (NMR, GC, GC-MS). We did manage to get a microanalysis. This polymer is constituted of 47.6% of carbon, 6.94% of hydrogen and 1.33% of nitrogen (coming from the acetonitrile using as reaction solvent). Unfortunately, we could not speculate any structure.

5.3.e. Other systems

Fluorination of 2-methyl-tetrahydrofuran using elemental fluorine was attempted using the same reaction conditions. After 18h a small amount of reaction was observed (5% conv.). No further investigation was carried out.

The direct fluorination of monoglyme using F_2 was performed and gave a crude mixture containing the starting material (100% recovered on the GC). The ^{19}F NMR suggested the presence of a product at -135.1ppm (signal was a doublet of triplet) but it was not detected on the GC. These results could suggest that the starting material does not have sufficient electron density to facilitate the fluorination reaction.

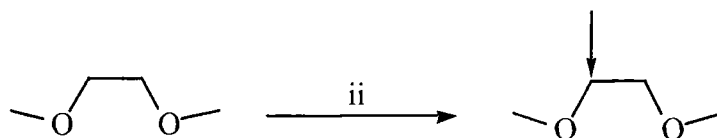

i=4 eq 10% F_2/N_2 , CH_3CN , $0^\circ C$.

Scheme 5.24

Fluorination of 18-crown-6 using elemental fluorine gave a crude product mainly composed of the starting material (100% area on the GC). Again a small doublet of triplet was seen on the ^{19}F NMR. No purification was performed due to an extremely low conversion.

5.4. Conclusion

In summary, fluorination of cyclic ethers using both elemental fluorine and Selectfluor™ gives very unusual and unexpected compounds as we observed the formation of fluorinated dimers.

By using Selectfluor™ fluorination of tetrahydrofuran and tetrahydropyran occurred in 100% conversion. Fluorine seems to be less reactive than Selectfluor™ towards cyclic ethers. The size of the ring seems to have an important effect as ring opening was observed (fluorination of hexamethylene oxide) when Selectfluor™ was used and a polymer was formed when fluorine was used.

Surprisingly, the fluorination of 2-methyl-tetrahydrofuran (bearing a richer C-H site than tetrahydrofuran) did not proceed. It could be explained by the large size of Selectfluor™. This reagent not able to reach the tertiary site. However we do not have any explanation concerning the very low conversion observed when fluorine was used.

CONCLUSION

Several conclusions can be made from our studies. First of all, the fluorination of ketones using both fluorine and Selectfluor™ gave different results. Only α -fluoro derivatives were isolated from the reaction using Selectfluor™, which is consistent with the literature^{92, 93}. The reactions were seen to be very clean and regiospecific. On the other hand, the fluorination of the same parent ketones using fluorine gave a mixture of isomers where fluorine takes place on a secondary site further away from the carbonyl (ewg). The fluorinations using elemental fluorine seem to be slower than those using Selectfluor™, occurring in lower conversion.

The second Chapter of this thesis was relative to the fluorination of aromatic and aliphatic aldehydes using fluorine. It has been observed that the fluorination of straight chain aldehydes occurs exclusively on the carbonyl (and not on the chain as observed for the ketones) giving rise to acyl fluorides. The latter ones were too unstable to be directly isolated. They were transformed into ester derivatives much more stable. Purification was then easily performed. In the case of the aromatic aldehydes fluorine attacks the ring when bearing an electron donating group or displace the aldehydic proton when bearing an electron withdrawing group. This can be due to the electron density of the ring as seen in Chapter Three p.77. We also applied the Selectfluor™ methodology to compare. A complicated mixture was isolated after work-up but no acyl fluoride was detected at all. No further investigation was carried out.

The last part of our studies on the fluorination of hydrocarbon systems containing an ewg was focused on the nitriles. No useful product was isolated due to very low conversion. The results obtained are not consistent with an electrophilic attack nor radical one.

The last Chapter of this thesis was probably the most surprising. It has been seen that the fluorination of cyclic ethers using both fluorine gas and Selectfluor™ gave very unusual and unexpected derivatives (seen in Chapter Five). The formation of these compounds can be explained by several postulations described from p.84 to p.104. All this work has to be extended to straight chain ethers.

The Use of Fluorine in the Laboratory

The fluorine/nitrogen (50% F₂/N₂) mixture is presented in high-pressure gas cylinders. The rig used for our experiments is fitted with a 4.5 litre cylinder which may be filled with 50% fluorine in nitrogen. Fluorine is delivered by a passivated stainless steel pipe to a passivated pipework rig fitted with Monel® valves. This rig can also be used to fill smaller cylinders which are useful for small scale fluorinations.

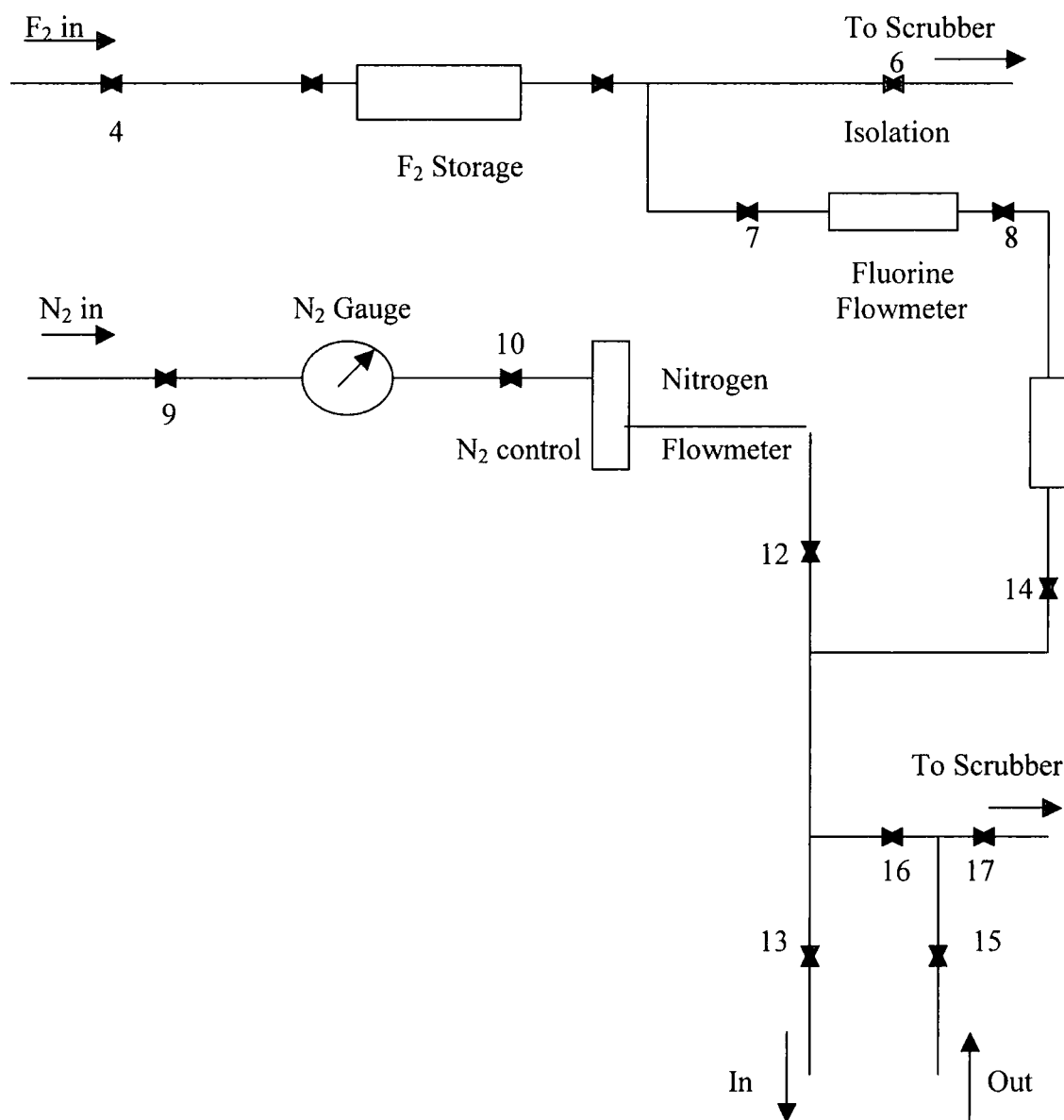

Instrumentation and Reagents

Reagents and Solvents

Chemicals were used as received from suppliers (Aldrich, Lancaster, Fluka). Solvents were dried before use by standard methods.

Elemental Analysis

Carbon, hydrogen and nitrogen elemental analysis were performed on either a Perkin-Elmer 240 or a Carlo Erba Elemental Analyser.

NMR Spectra

^1H , ^{13}C and ^{19}F NMR spectra were recorded on either a Varian Gemini 200, a Varian VXR 400S or Bruker AC250 and 500 NMR spectrometer.

Mass Spectra

Mass Spectra were recorded on either a VG 7070E spectrometer or a Fissons VG Trio 1000 linked to a Hewlett Packard 5790A gas chromatograph.

Gas Liquid Chromatography Analysis

Analyses were performed using a Hewlett Packard 5890A gas liquid chromatograph.

FT/IR Spectra

Infra Red spectra were carried out on a Perkin-Elmer 1600 FT IR spectrometer using KBr discs (for solid samples) or thin films between two KBr plates (for liquid samples).

Melting Points

Melting points were recorded at atmospheric pressure and are uncorrected.

Chapter Six Experimental to Chapter Two

6.1 Preparation of fluorinated cyclic and acyclic ketones using Selectfluor™

General procedure

A reaction mixture containing a ketone and Selectfluor™ in dry acetonitrile was stirred at reflux temperature in a round bottom flask overnight. After this time, water (200ml) was added to quench the reaction. The organic layer was separated off and the aqueous one further extracted using dichloromethane (3x140ml). The extract was dried (MgSO₄), filtered and the solvent removed under reduced pressure. Purification was achieved by column chromatography using hexane/ethyl acetate as eluent or preparative GC.

a). 2-Heptanone

Selectfluor™ (17.04g , 48 mmol) and 2-heptanone (5.00g , 44 mmol) in dry MeCN (170ml) left, after work up, a brown crude product (4.67g). The ¹⁹F NMR allowed us to detect the presence of one monofluorinated derivative (85% conversion) and other by-products. The 3-fluoro-2-heptanone (3.26g, 56%) was isolated using preparative GC as a yellow liquid ; bp 130°C (Found : C, 63.4; H, 9.9%. C₇H₁₃FO requires C, 63.6; H, 9.8%); $\nu_{\max}/\text{cm}^{-1}$ 1727 (C=O), 1078 (C-F); m/z (EI⁺) 132 (M⁺, 1%), 76 (8), 43 (100). NMR Table No.1

b). 2-Octanone

Selectfluor™ (15.25g, 43 mmol) and containing 2-octanone (5.00g , 39 mmol) in dry acetonitrile (153 ml) gave, after work up, a yellow crude product (4.13g) containing one fluorinated product (84% conversion). The 3-fluoro-2-octanone (3.24g, 65%) was isolated using preparative GC as a colourless liquid; mp 151°C (Found : C, 65.4; H,

10.4%. $C_8H_{15}FO$ requires C, 65.7; H, 10.3%); $\nu_{\max}/\text{cm}^{-1}$ 1726 (C=O), 1081 (C-F); m/z (EI^+) 146 (M^+ , 4%), 111 (0.2), 99 (0.9), 76 (31), 55 (8). NMR Table No.2.

c). 2,5-Hexanedione

Selectfluor™ (17.13g, 48 mmol) and 2,4-hexanedione (5.00g, 44 mmol) in dry acetonitrile gave, after work up, a black crude product (4.57g) containing 2 fluorinated products in the ratio 8:1 detected on the ^{19}F NMR. An orange liquid (3.13g, 54%) isolated as a mixture of 3-fluoro-hexan-2,5-dione and its elimination product using 2 hexane:1 ethyl acetate; $\nu_{\max}/\text{cm}^{-1}$ 1715 (C=O), 1160 (C-F); (exact mass calcd for C_6H_9FO 132.058658, found 132.058773); m/z (EI^+) 132 (M^+ , 65%), 112 (2), 97 (22), 89 (55) as 3-fluoro-hexan-2,5-dione. NMR Table No 3. $\nu_{\max}/\text{cm}^{-1}$ 1683 (C=C) as hex-3-ene-2,5-dione. NMR Table No 4.

d). Cyclopentanone

Selectfluor™ (23.24g, 66 mmol) and cyclopentanone (5.00g, 60 mmol) in dry MeCN (232ml) gave, after work up, a brown crude product (4.43g) containing one monofluorinated product (from the ^{19}F NMR) in 84% conversion. The 2-fluoro-cyclopentanone (3.14g, 58% yield) was isolated using hexane/ethyl acetate (1:1) as a yellow liquid ; bp 165°C (exact mass calcd for C_5H_7FO 102.048093, found 102.048035); $\nu_{\max}/\text{cm}^{-1}$ 1761 (C=O), 1000-1014 (C-F); m/z (EI^+) 102 (M^+ , 5%), 82 (M^+-HF , 7), 28(100). NMR Table No.5.

e). Cyclohexanone

Selectfluor™ (19.92g, 56 mmol) and cyclohexanone (5.00g, 51 mmol) reacted in dry MeCN (199ml) to give a brown crude product (4.73g). The ^{19}F NMR showed the presence of one monofluorinated compound (in 93% conversion). The 2-fluoro-cyclohexanone (3.26g, 59% yield) was isolated using hexane/ethyl acetate (2:1) as a yellow liquid; bp 185°C (exact mass calcd for $\text{C}_6\text{H}_9\text{FO}$ 116.063743, found 116.063692); $\nu_{\text{max}}/\text{cm}^{-1}$ 1733 (C=O), 1069-1087 (C-F); m/z (EI $^+$) 116 (M^+ , 37%), 72(12), 59(34), 55(100), 42(63). NMR Table No.6.

f). Cycloheptanone

Selectfluor™ (17.43g, 49 mmol) and cycloheptanone (5.00g, 45 mmol) in dry MeCN (174ml) gave a brown crude product (4.81g) containing one monofluorinated derivative (from the ^{19}F NMR) in 73% conversion. Analysis by GC-MS showed the presence of 2-fluoro-cycloheptanone. This derivative (3.14g, 56% yield) was isolated using hexane/ethyl acetate (2:1) as a yellow liquid ; bp 177°C (exact mass calcd for $\text{C}_7\text{H}_{11}\text{FO}$ 130.079393, found 130.079362); $\nu_{\text{max}}/\text{cm}^{-1}$ 1723 (C=O), 1010-1031 (C-F) ; m/z (EI $^+$) 130 (M^+ , 2%), 110 ($\text{M}^+ - \text{HF}$, 2), 32(43), 28(100). NMR Table No.7.

6.2 Preparation of fluorinated cyclic and acyclic ketones using elemental fluorine

General procedure

A solution consisting of ketone and acetonitrile (140ml) was prepared in a glass reaction vessel fitted with overhead stirrer. The solution was cooled to 0°C in a salt water bath using a HAAKE cryostat. Elemental fluorine in 10% dilution with nitrogen was passed through the solution at a rate of 13 mmol/h overnight. Some reactions have been done

using a catalyst to promote the formation of the α -fluorinated compound. The reaction mixture was poured into water (200ml), neutralised (NaHCO_3) and extracted with dichloromethane (3x140ml) then dried (MgSO_4). The excess of solvent removed under reduced pressure. Purification was achieved by column chromatography on silica gel using hexane/ethyl acetate as eluent.

a). 2-Heptanone

Elemental fluorine (312 mmol) and 2-heptanone (5.00g, 44 mmol) in dry MeCN (140 ml) gave a brown product (4.25g) after reaction. The ^{19}F NMR showed the presence of 2 major fluorinated compounds in the ratio 1:1.1. The 5- and 6-fluoro-heptanone (3.61g, 63% yield) were isolated using hexane/ethyl acetate (3:1) as a yellow liquid; (exact mass calcd for $\text{C}_7\text{H}_{12}\text{O}$ 112.088815, found 112.088795); $\nu_{\text{max}}/\text{cm}^{-1}$ 1717 (C=O), 1083-1170 (C-F); m/z (CI^+) 150 ($\text{M}^+ + \text{NH}_4^+$), 130 ($\text{M}^+ - \text{NH}_4^+$) as 5-fluoro-heptanone and 6-fluoro-heptanone. NMR Tables No.8 and 9.

b). 2- Heptanone and catalysts

1) Using 1 equivalent of triflic acid

Fluorine (66 mmol), 2-heptanone (3.76g, 33 mmol) and triflic acid (4.95g, 33 mmol) gave a brown crude product (4.04g) containing some starting material (50% area by GC), 5-fluoro-2-heptanone and 6-fluoro-2-heptanone (7% and 9% area by GC); δ_{F} (188 MHz, CDCl_3) -132 to -140 (3.8F, m), -174.65 (7.8F, m), -184.72 (6F, m), -188 to -208 (7.7F, m), -218 to -228 (1F, m), -218 to -236 (2.2F, m); m/z (EI^+) 132 (M^+ , 0.2%), 112 (9), 97 (12), 83 (5), 69 (17), 58 (34), 43 (100).

2) Using 5 equivalents of triflic acid

Fluorine (66 mmol), 2-heptanone (3.76g, 33 mmol) and triflic acid (24.75g, 165 mmol) gave an orange crude product (4.97g) containing some starting material (70% area by GC), 5-fluoro-2-heptanone and 6-fluoro-2-heptanone (3% and 8% area by GC); δ_F (188 MHz, $CDCl_3$) -123.21 (7.78F, m), -173.19 (32.43F, m), -181 (3.75F, m), -182.87 (10.25F, m), -184 to -226 (0.16F, m), -226 to -240 (20.68F, m); m/z (EI^+) 132 (M^+ , 0.2%), 112 (9), 97 (12), 83 (5), 69 (17), 58 (34), 43 (100).

3) Using 10% of Selectfluor™

Fluorine (234 mmol), 2-heptanone (5.34g, 47 mmol) and Selectfluor™ (1.67g, 4.7 mmol) gave an orange crude product (6.92g) containing some starting material (74% area by GC), 5-fluoro-2-heptanone and 6-fluoro-2-heptanone (11% and 11% area by GC); δ_F (188 MHz, $CDCl_3$) -66 to -144 (0.32F, m), -151.08 (5F, m), -172.63 (45.7F, m), -182.8 (40.4F, m), -184 to -210 (1.80F, m), -216 to -240 (6.9F, m); m/z (EI^+) 132 (M^+ , 0.2%), 112 (9), 97 (12), 83 (5), 69 (17), 58 (34), 43 (100).

4) Using 2 equivalents of $BF_3 \cdot Et_2O$

Fluorine (234 mmol), 2-heptanone (6.30g, 55 mmol) and $BF_3 \cdot Et_2O$ (15.69g, 111 mmol) gave a brown crude product (4.46g) containing some starting material (70% from GC), the 3-fluoro-2-heptanone (12%) and 5 other unidentified products. The ^{19}F NMR showed the presence of 3-fluoro-2-heptanone (detected by ^{19}F NMR); δ_F (188 MHz, $CDCl_3$) -60 to -106 (1.61F, m), -109.7 (0.1F, m), -112.95 (0.6F, m), -149.57 (2.1F, m), -190.1 (8.5F, m), -195.3 (6.6F, m); m/z (EI^+) 132 (M^+ , 4%), 76(12), 43(100).

5) Using 10% of copper nitrate

Fluorine (52 mmol), 2-heptanone (2.28g, 20 mmol) and copper nitrate (0.46g, 2 mmol) gave a yellow crude product (3.54g) containing starting material (76% area by GC), the 6-fluoro-2-heptanone and the 5-fluoro-2-heptanone (12% and 12% area by GC); δ_F (188 MHz, $CDCl_3$) -112 to -148 (1.00F, m), -169 (42.9F, m), -178.9 (45.7F, m), -182 to -190 (1.3F, m), -220 to -230 (0.3F, m); m/z (El^+) 132 (M^+ , 0.2%), 112 (9), 97 (12), 83 (5), 69 (17), 58 (34), 43 (100).

6) Using 0.6 equivalent of Cerium Ammonium Nitrate

Fluorine (26 mmol), 2-heptanone (4.90g, 43 mmol) and CAN (12.06g, 22 mmol) gave a yellow crude product (3.78g) containing starting material (80% area by GC). The 3-, 5- and 6-fluoro-heptanone in the ratio 1:14:15 were detected from the ^{19}F NMR; δ_F (188MHz, $CDCl_3$) -172.66(15F, m), -182.85 (15F, m), -189.84 (1F, m).

7) Using 10% of $AlCl_3$

Fluorine (312 mmol), 2-heptanone (5.02g, 44 mmol) and $AlCl_3$ (0.58g, 4.4 mmol) in dry acetonitrile gave a dark orange crude product (4.78g) containing starting material (6% area by GC). 5- and 6-fluoro-heptanone were detected on the ^{19}F NMR, δ_F (188MHz, $CDCl_3$) -172.92 (1.3F, m), -183.20 (1F, m).

b). 2,5-Hexanedione

Elemental fluorine (234 mmol) and 2,5-hexanedione (6.73g, 59 mmol) in dry acetonitrile gave an orange crude product after work up. The ^{19}F NMR showed the presence of the 3-fluoro-acetyl acetone and 5 other unidentified fluorinated products in the ratio

1.2:1:2:1.7; δ_F (188MHz, $CDCl_3$) -69.13 (2F, m), -127.56 to -129.03 (1F, 3d, $^2J_{HF}$ 53, $^2J_{HF}$ 54, $^2J_{HF}$ 53), -137.76 (1.7F, dd, $^2J_{HF}$ 54, $^4J_{HF}$ 6.4), -189.56 (1.2F, dtq, $^2J_{HF}$ 47.6, $^3J_{HF}$ 25.6, $^4J_{HF}$ 4.5). Analysis by GC-MS confirmed the presence of 3-fluoro-hexan-2,5-dione.

c). Cyclopentanone

Elemental fluorine (234 mmol) and cyclopentanone (4.96g, 59 mmol) in dry acetonitrile (140ml) gave a dark orange crude mixture (5.12g). The ^{19}F NMR showed the presence of 2- and 3-fluoro-cyclopentanone and a difluorinated compound (presumably the 2,2-difluoro-cyclopentanone) in the ratio 1:2.5:2. Purification by column chromatography was attempted several times using different eluents. It has not been possible to get any pure isomer. Analysis by GC-MS allowed us to identify the 2-fluoro (by comparison with previous experiment done using Selectfluor™); δ_F (188MHz, $CDCl_3$) -70.99 (2F, t or dd, $^3J_{HF}$ 8.3), -177.25 (2.5F, dm, $^2J_{HF}$ 45.7), -195.83 (1F, dm, $^2J_{HF}$ 51.1).

d). Cyclohexanone

Elemental fluorine (234 mmol) and cyclohexanone (5.78g, 59 mmol) in dry acetonitrile (140ml) gave a brown crude containing 3 fluorinated products. The ^{19}F NMR showed the presence of 2-, 3- and 4-fluoro-cyclohexanone in the ratio 1:3.7:10. The 2- and 3-fluoro-cyclohexanone (2.86g, 42% yield) were isolated in the ratio 2:1 using hexane/ethyl acetate (3:1) as a yellow liquid; (exact mass calcd for C_6H_9FO 116.063743, found 116.063639); ν_{max}/cm^{-1} 1727 (C=O), 1032 (C-F); m/z (EI^+) 116(M^+ , 37%), 55(100), 42(63), 39(39) as 2-fluoro-cyclohexanone and 3-fluoro-cyclohexanone. No trace of the major compound was found after column. NMR Tables No 2 and 10.

e). Cycloheptanone

Elemental fluorine (234 mmol) and cycloheptanone (6.61g, 59 mmol) in dry acetonitrile (140ml) gave an orange crude (6.45g). Analysis by ^{19}F NMR showed the presence of 2-, 3- and 4-fluoro-cycloheptanone in the ratio 1:1.4:3.2. A purification by column using 3:1 hexane/ethyl acetate allowed us to get the 3- and 4-fluoro-cycloheptanone (3.27g, 43% yield) obtained in the ratio 1:3 as a yellow oil; (exact mass calcd for $\text{C}_7\text{H}_{11}\text{FO}$ 130.079393, found 130.079362); $\nu_{\text{max}}/\text{cm}^{-1}$ 1703 (C=O), 1004 (C-F); m/z (EI^+) 130 (M^+ , 97%), 110 ($\text{M}^+ - \text{HF}$, 23), 86 (36), 74 (91), 68 (100), 55 (97) as 3-fluoro-cycloheptanone and 4-fluoro-cycloheptanone. NMR Tables No 11 and 12.

7.1 Preparation of acyl fluorides

General procedure

A solution containing an aldehyde (straight chain or aromatic one) and acetonitrile (140ml) was placed in a flask fitted with overhead stirrer. The solution was cooled to 0°C. Elemental fluorine in nitrogen (10% dilution) was passed through the solution at a rate of 13 mmol/h overnight. Then, some 3,5-dinitrobenzyl alcohol was added to the reaction mixture and heated up at 82°C. After cooling the reaction mixture was poured into water (200ml), neutralised (NaHCO₃) then extracted with dichloromethane (3x140ml). This extract was dried (MgSO₄) and the excess of solvent was removed under reduced pressure. Purifications were achieved by column chromatography using dichloromethane as eluent.

a). Nucleophilic substitution of chloride using heptanoyl chloride and 3,5-dinitrobenzyl alcohol (reaction test)

A mixture consisting of heptanoyl chloride (1.0g, 7 mmol) and 3,5-dinitrobenzyl alcohol (1.0g, 5 mmol) in dry acetonitrile (50ml) was stirred at room temperature. The reaction mixture was poured into water, extracted (dichloromethane) and dried (MgSO₄). The organic phase was evaporated to give an orange crude product (1.93g) containing some heptanoyl chloride (7% by GC) and a major compound (93% by GC). The (3,5-dinitrophenyl)methyl heptanoate (1.34g, 62%) was isolated by column chromatography using 100% dichloromethane as a pale yellow solid; mp 39-41°C; $\nu_{\max}/\text{cm}^{-1}$ 1743 (C=O), 1541 (C-NO₂); (Found: C, 54.0; H, 5.8; N, 8.9 C₁₄H₁₈N₂O₆ requires C, 54.2; H, 5.9; N, 9.0%); m/z (EI⁺) 223(54), 181(48), 129(13), 43(100). NMR Table No 13.

b). Heptanal

Elemental fluorine (234 mmol) was passed through a solution of heptanal (6.61g, 58 mmol) and dry acetonitrile (140ml). The ^{19}F NMR of the solution showed the presence of heptanoyl fluoride ($\delta_{\text{F}}=+44.91\text{ppm}$) in 66 % yield evaluated by using a known amount of fluorobenzene as reference. After, 3,5-dinitrobenzyl alcohol (5g, 25 mmol) was added to the reaction mixture. This solution was heated up for 20h and gave rise to a brown crude product (8.56g) containing one major compound on the GC (84% conv.). No more acyl fluoride was detected on the ^{19}F NMR. The ester derivative (3,5-dinitrophenyl)methyl heptanoate (7.76g, 43%) was isolated as a pale yellow solid after column chromatography; mp 38-40°C (Found: C, 53.9; H, 5.8; N, 8.9 $\text{C}_{14}\text{H}_{18}\text{N}_2\text{O}_6$ requires C, 54.2; H, 5.9; N, 9.0%). NMR Table No.13.

c). Decanal

Elemental fluorine (234 mmol) was passed through a solution of decanal (9.05g, 58 mmol) in dry acetonitrile (140ml). Decanoyl fluoride (70% yield) was detected by ^{19}F NMR ($\delta_{\text{F}}=+44.92\text{ppm}$) after direct fluorination reaction using a known amount of fluorobenzene as reference. No presence of other fluorinated compound was shown. Then, 3,5-dinitrobenzyl alcohol (5g, 25 mmol) poured into the reaction mixture and submitted to reflux (82°C) overnight. After work up, no more acyl fluoride appeared on the NMR. The (3,5-dinitrophenyl)methyl decanoate (11.13g, 55%) was isolated as a white solid after column; $\nu_{\text{max}}/(\text{cm}^{-1})$ 1745 (C=O), 1546 (C-NO₂); mp= 32-33°C; (Found: C, 57.7; H, 6.9; N, 7.7 $\text{C}_{17}\text{H}_{24}\text{N}_2\text{O}_6$ requires C, 57.9; H, 6.9; N, 7.9%); m/z (EI⁺) 352 (M⁺, 3%), 223(42), 181(100), 171(31), 135(60), 69(51), 57(60), 55(88), 43(97). NMR Table No.14.

d). Benzaldehyde

Elemental fluorine (234 mmol) was passed through a solution of benzaldehyde (6.15g, 58 mmol) and dry acetonitrile (140ml). Less than 1% of benzoyl fluoride was detected in

the reaction mixture by ^{19}F NMR using the same method as above. Three major fluorinated derivatives were present in solution. Despite a very low conversion into acyl fluoride, 3,5-dinitrobenzyl alcohol (4.09g, 21 mmol) was added to the previous reaction mixture. After 3 days at reflux temperature and the usual work up, the crude brown crude product (9.68g) contained 3 monofluorinated (in the *ortho*, *meta* and *para* positions) benzaldehyde derivatives (43% conv.) in the ratio 4.3:8.2:1; δ_{F} (188MHz, CDCl_3), -103.54 (1F, m), -112.09 (5F, m), -121.65 (2.3F, m); m/z (EI^+) 124 (M^+ , 98%), 123(100), 95(69) for the three compounds (detected in the same peak on the GC-MS). The NMR is consistent the literature¹⁰⁰. The attempt of purification failed.

e). Trifluoromethyl-*para*-tolualdehyde

Elemental fluorine (234 mmol) and trifluoromethyl-*para*-tolualdehyde (10.32g, 58 mmol) in dry acetonitrile (140ml) gave a reaction mixture containing some acyl fluoride (50% yield on the ^{19}F NMR) and two minor fluorinated compounds. 3,5-Dinitrobenzyl alcohol (5.00g, 25 mmol) was poured into the previous mixture. After one day heating and the usual work up, a brown crude product (3.80g) was obtained. The ^{19}F NMR did not show any more acyl fluoride. The two minor compounds were still present in solution in the ratio 1:1 and identified as 2-and 3-fluoro-trifluoromethyl-*para*-tolualdehyde from the ^{19}F NMR; δ_{F} (188MHz, CHCl_3) -120.26 (C-F, dd), -63.69 (CF_3 , s) as the 2-fluorotrifluoromethyl-*para*-tolualdehyde and δ_{F} (188MHz, CHCl_3) -114.23 (C-F, dd), -62.67ppm (CF_3 , d). The (3,5-dinitrophenyl)methyl 14-(trifluoromethyl)benzoate (11.85g, 55%) was isolated after purification as a white solid ; $\nu_{\text{max}}/\text{cm}^{-1}$ 1713 (C=O), 1547 (C- NO_2), 1135-1413 (C-F); mp 137-139°C (Found: C, 48.2; H, 2.4; N, 7.4 $\text{C}_{15}\text{H}_9\text{N}_2\text{O}_6\text{F}_3$ requires C, 48.6; H, 2.5; N, 7.6); m/z (EI^+) 371 (M^+ , 0.03%), 197(1), 173(100). NMR Table No.15.

f). *para*-Tolualdehyde

Elemental fluorine (234 mmol) and *para*-tolualdehyde (14.04g, 117 mmol) in dry acetonitrile (140ml) gave a mixture containing only compound on the ^{19}F NMR at $\delta_{\text{F}}=-115.9\text{ppm}$. After the usual work up and drying, a brown crude product (13.65g) was obtained which contained the 3-fluoro-*para*-tolualdehyde (64% conv., 100% yield); δ_{F} (188MHz, CDCl_3), -115.93 (30F, m), -213.29 (3F, t, $^2\text{J}_{\text{FH}}$ 47); m/z (EI^+) 138 (M^+ , 83%), 137(100), 109(82) as compared with the literature¹⁰⁰.

g). Fluorination of heptanal using Selectfluor™

Selectfluor™ (17.04g, 48 mmol) and heptanal (5.00g, 44 mmol) in dry acetonitrile gave a brown crude product (4.66g) after work up. The ^{19}F NMR showed the presence of 6 fluorinated products in the ratio 4.2:2:3.9:1:7.4:6.6. δ_{F} (188MHz, CHCl_3) -103.53 (t, $^3\text{J}_{\text{HF}}$ 17.5), -118.25 (m), -124.80 (d, $^2\text{J}_{\text{HF}}$ 53.4), -142.54 (m), -175.14 (m), -213.71 (m).

9.1 Preparation of fluorinated nitriles using Selectfluor™

General procedure

A reaction mixture containing a nitrile and Selectfluor™ in dry acetonitrile was stirred at reflux temperature in a round bottom flask overnight. After this time, water (200ml) was added to quench the reaction. The organic layer was separated off and the aqueous one further extracted using dichloromethane (3x140ml). The extract was dried (MgSO₄), filtered and the solvent removed under reduced pressure.

a). Heptanenitrile

Selectfluor™ (17.59g, 49.5 mmol) and heptanenitrile (5.00g, 45 mmol) in dry acetonitrile gave a yellow crude product (4.04g) containing 4 fluorinated compounds in the ratio 10:3.4:1:1.2. Despite a low conversion a purification by column using hexane/ethyl acetate (4:1) gave a mixture of 5-, 6- and 7-fluoro-heptanenitrile (1.3g, 26% yield) as a colourless product and in the ratio 1.1:7.5:1; $\nu_{\max}/\text{cm}^{-1}$ 2246 (C=N), 1135 (C-F); m/z (EI⁺) 100(M⁺-HF, 3%), 82(84), 55(59), 41(100) as 5-fluoro-heptanenitrile. NMR Table No.16.

m/z (EI⁺) 129(M+0.1%), 100(M⁺-HF, 31), 82(4), 55(16), 41(100) as 6-fluoro-heptanenitrile. NMR Table No.17.

m/z (EI⁺) 100(M⁺-HF, 3), 82(84), 55(59), 41(100) as 7-fluoro-heptanenitrile. NMR Table No.18.

b). 1,5-Dicyanopentane

Selectfluor™ (11.11g, 31.3 mmol) and 1,5-dicyanopentane (3.47g, 28.5 mmol) were stirred and heated up together in dry acetonitrile during 5 days. After the usual work up, the crude product (2.9g) was submitted to GC and ¹⁹F NMR. The first one showed the presence of the starting material only. A mixture of 5 unidentified fluorinated products in the ratio 1.4:1:5.5:12.3:11.7 were detected by ¹⁹F NMR in <1% conversion. No further investigation was carried out.

9.2 Preparation of fluorinated nitriles using elemental fluorine

General procedure

A solution containing a nitrile and acetonitrile (140ml) was placed in a glass vessel with overhead stirrer. The solution was cooled to 0°C. Elemental fluorine in 10% dilution in nitrogen was passed through the solution at a rate of 13 mmol/h overnight. Then, either 1,4-dimethoxybenzene or anisole were added in some cases to the reaction pot and heated up several hours. The reaction mix was poured into water (200ml), neutralised (NaHCO₃) then extracted with dichloromethane (3x140ml). This extract was dried (MgSO₄) and the excess of solvent was removed under reduced pressure.

a). Octanenitrile

Elemental fluorine (234 mmol) and octanenitrile (1.70g, 14 mmol) in dry acetonitrile gave an orange crude product (1.77g) after work up. The ¹⁹F NMR showed the presence of mixture of several fluorinated compounds as the NMR was not clear. The 5-, 6- and 7-fluoro-octanenitrile (0.86g, 43%) as a yellow liquid after column chromatography using hexane/ethyl acetate (4:1); $\nu_{\text{max}}/\text{cm}^{-1}$ 2247 (C=N), 1132 (C-F) (exact mass calcd for C₈H₁₄FN 142.103203, found 142.103065);

m/z (EI⁺) 142(M⁺, 1%), 122(3), 100(70), 65(100) as 6-fluoro-octanenitrile. NMR Table No.19.

m/z (EI⁺) 142 (M⁺, 12%), 122 (53), 114 (77), 94 (100) as 5-fluoro-octanenitrile. NMR Table No.20.

m/z (EI⁺) 142 (M⁺, 4%), 122 (13), 114 (40), 101 (100), 94 (56) as 7-fluoro-octanenitrile. NMR Table No.21.

b). Heptanenitrile

Elemental fluorine (234 mmol) and heptanenitrile (3.66g, 33 mmol) in dry acetonitrile (140ml). The reaction was worked up and submitted to ¹⁹F NMR. The orange crude product (4.72g) contained 5-, 6- and 7-fluoro-heptanenitrile as well as 3- or 4-fluoro-heptanenitrile in the ratio 40:32:4:1; δ_F (188MHz, CDCl₃) -172.51 (dm, ²J_{FH} 52), -182.20 (dm, ²J_{FH} 47.3), -184.06 (dm, ²J_{FH} 48.1), -218.11 (tt, ²J_{FH} 47.3, ³J_{FH} 22.7).

c). 1,5-dicyanopentane

Elemental fluorine (234 mmol) was passed through a solution of 1,5-dicyanopentane (7.20g, 59mmol) and acetonitrile (140ml). An orange crude product (7.19g) was obtained after work up. Analysis by ¹⁹F NMR showed the presence of two fluorinated compounds in the ratio 1:2.3. No further investigation was carried out due to 1% conversion.

8.1 Preparation of fluorinated dimers of cyclic ethers using Selectfluor™

General procedure

A reaction mixture containing a cyclic ether and Selectfluor™ in dry acetonitrile was stirred at reflux temperature in a round bottom flask overnight. After this time, water (200ml) was added to quench the reaction and the reaction mixture was neutralised (NaHCO₃). The organic layer was separated off and the aqueous one further extracted using dichloromethane (3x140ml). The extract was dried (MgSO₄), filtered and the solvent removed under reduced pressure. Purification was achieved by column chromatography using hexane/ethyl acetate as eluent.

a). Tetrahydrofuran

Selectfluor™ (10.86g, 30.58 mmol) and tetrahydrofuran (2.00g, 27.8 mmol) in dry MeCN gave a brown crude product after reaction (1.28g) presenting one peak on the ¹⁹F NMR. The 3-fluoro-2-(3-fluorooxolan-2-yloxy)oxolane (1.84g, 35%) was isolated as a yellow liquid after column (2:1); $\nu_{\max}/\text{cm}^{-1}$ 1135-1413 (C-F); (Found C, 50.17; H, 6.46. Calc. for C₈H₁₂F₂O₃ requires C, 49.48; H, 6.23%); the difference observed between the two results could be explained by the fact that the the sample was not completely free of solvent ; m/z (ES⁺) 217.1 (M⁺+Na⁺). NMR Table No.22.

b). Tetrahydropyran

Selectfluor™ (4.54g, 12.79 mmol) and tetrahydropyran (1.00g, 11.62 mmol) in dry MeCN gave an orange crude product (3.51g) after work up. The ^{19}F NMR of the crude showed the presence of 2 fluorinated compounds in the ratio 1:1. The 3-fluoro-2-(3-fluoroperhydro-2H-pyran-2-yloxy)perhydro-2H-pyran was obtained as a slightly yellow product (1.18g, 40%) after column (2:1) (Found C, 55.19; H, 7.25. Calc. for $\text{C}_{10}\text{H}_{16}\text{F}_2\text{O}_3$ requires C, 54.05; H, 7.26%); same explanation as above; m/z (ES^+) 245.1 (M^+Na^+). NMR Table No.23.

c). 1,4-Dioxane

Selectfluor™ (8.87g, 25 mmol) and 1,4-dioxane (2.00g, 22.70 mmol) in dry MeCN gave a dark orange crude product (1.06g) after work up. The ^{19}F NMR of the crude showed the presence of one major peak (<1% conv.) and a major peak on the GC (100% yield). A white solid, 2,5,7,10-tetraoxabicyclo[4.4.0]decane, was isolated (1.18g, 36%) after column (2:1); mp 139-140°C; (Found C, 50.90; H, 7.29 Calc. for $\text{C}_6\text{H}_{10}\text{O}_4$ requires C, 49.31; H, 6.90%); m/z (EI^+) 146 (M^+ , 0.5%), 86(38), 73(100). NMR Table No.24.

d). Hexamethylene oxide

Selectfluor™ (7.81g, 22 mmol) and hexamethylene oxide (2.00g, 20.00 mmol) in dry MeCN gave after reaction, a brown crude (1.56g) containing 2 peaks on the ^{19}F NMR as two different fluorines in the same molecule. The 2-fluoro-5-(3-fluorooxepan-2-yloxy)pentanal was isolated as a yellow oil (1.56g, 31%) after column (3:1); (Found C, 57.50; H, 8.21. Calc. for $\text{C}_{12}\text{H}_{20}\text{F}_2\text{O}_3$ requires C, 57.59; H, 8.05%); m/z (CI^+) 268 (M^+NH_4^+), 250 (30), 183 (6), 134 (40), 99 (100). NMR Table No.25.

e). 2-Methyl-tetrahydrofuran

Selectfluor™ (9.08g, 25.6 mmol) and 2-methyl-tetrahydrofuran (2.00g, 23.3 mmol) in dry MeCN gave a brown crude product (1.74g) containing 5 fluorinated products detected on the ^{19}F NMR after work up. No purification was done because of only 3% conversion observed on the ^{19}F NMR.

f). Monoglyme

Selectfluor™ (8.68g, 24.4 mmol) and monoglyme (2.00g, 22.2 mmol) in dry MeCN gave a brown crude product (1.45g) containing the starting material only (100% recovery from the GC). No ^{19}F NMR signal was detected.

g). 18-Crown-6

Selectfluor™ (2.96g, 8.33 mmol) and 18-crown-6 (2.00g, 7.58 mmol) in dry MeCN gave an orange crude product (2.19g) containing the starting material only (100% recovery from the GC). No ^{19}F NMR signal was detected.

8.2. Preparation of fluorinated dimers using elemental fluorine

General procedure

A solution containing a cyclic ether and acetonitrile (140ml) was placed in a flask fitted with overhead stirrer. The solution was cooled to 0°C. Elemental fluorine in 10% dilution in nitrogen was passed through the solution at a rate of 13 mmol/h overnight. The reaction mixture was poured into water (200ml), neutralised (NaHCO_3) then extracted with dichloromethane (3x140ml). This extract was dried (MgSO_4) and the excess of

solvent was removed under reduced pressure. Purifications were attempted by column chromatography using hexane/ethyl acetate as eluent.

a). Tetrahydrofuran

Elemental fluorine (234 mmol) was passed through a solution of tetrahydrofuran (4.25, 59 mmol) and dry acetonitrile. After an aqueous work up, three compounds were detected by GC in the ratio 2:1:3.4. The major compound was 3-fluoro-2-(3-fluorooxolan-2-yloxy)oxolane detected on the GC and the ^{19}F NMR. The brown crude product (4.18) was submitted to purification several times preparative GC, columns using different eluents but these attempts failed.

b). Tetrahydropyran

Elemental fluorine (234 mmol) reacted with tetrahydropyran (4.96g, 59 mmol) in dry acetonitrile to give a brown crude product (3.01g) containing the same compound seen previously as major compound and 4 others fluorinated derivatives in the ratio 4:2.4:1.4:1. Several attempts of purification were attempted but they all failed.

c). 1,4-Dioxane

Elemental fluorine (234 mmol) was passed through a solution of 1,4-dioxane (10.29g, 117 mmol) in dry acetonitrile. The fluorine NMR of the crude product showed the presence of 4 different compounds in the ratio 2:4:1:10. The major compound has been extracted as a white solid from the crude product by adding some dichloromethane. The 2,5,7,10-tetraoxabicyclo[4.4.0]decane (4.25, 25%) was obtained; (Found C, 50.43; H, 7.26 Calc.for $\text{C}_6\text{H}_{10}\text{O}_4$ requires C, 49.31; H, 6.90%). Difference explained previously. NMR data and GC-MS already given previously.

d). Hexamethylene oxide

Elemental fluorine (234 mmol) and hexamethylene oxide (5.9g, 59 mmol) in dry acetonitrile gave an orange then brown crude product giving rise to an unidentified polymer (7.26g). It was impossible to find any suitable solvent to run any analysis. We only did manage to get the microanalysis of this compound: C, 47.6; H, 6.94; N, 1.33% (presumably coming from the acetonitrile). No further investigations were attempted.

e). 2-Methyl-tetrahydrofuran

Elemental fluorine (234 mmol) and 2-methyl-tetrahydrofuran (10.06g, 117 mmol) in dry MeCN gave a black oil (8.54g). Only the starting material was 100% recovered by GC. The ^{19}F NMR was messy and could not be understood. No purification was done because of the very low conversion (5%).

f). Monoglyme

Elemental fluorine (234 mmol) and monoglyme (5.31g, 59 mmol) in dry acetonitrile gave a colourless crude product after work up. The GC-MS showed the presence of the starting material only. Analysis by ^{19}F NMR allowed us to detect a compound presenting a doublet of triplet at -135.08ppm which could fit with a monofluorinated derivative on the secondary site. The conversion was too low to do any purification.

g). 18-Crown-6

Elemental fluorine (234 mmol) and 18-crown-6 (15.57g, 59 mmol) in dry acetonitrile gave a crude product containing a solid. The GC-MS showed the presence of the starting material only. Analysis by ^{19}F NMR allowed us to detect a compound presenting a doublet of triplet which could fit with a monofluorinated derivative. Again, the conversion was too low to do any purification.

Appendix One: Nuclear Magnetic Resonance

Table No.1	3-Fluoro-2-heptanone (14).
Table No.2	3-Fluoro-2-octanone (15).
Table No.3	3-Fluoro-hexan-2,5-dione (16).
Table No.4	Hex-3-ene-2,5-dione (17).
Table No.5	2-Fluoro-cyclopentanone (18).
Table No.6	2-Fluoro-cyclohexanone (19).
Table No.7	2-Fluoro-cycloheptanone (20).
Table No.8	5-Fluoro-2-heptanone (21).
Table No.9	6-Fluoro-2-heptanone (22).
Table No.10	3-Fluoro-cyclohexanone (23).
Table No.11	3-Fluoro-cycloheptanone (24).
Table No.12	4-Fluoro-cycloheptanone (25).
Table No.13	(3,5-dinitrophenyl)methyl heptanoate (26).
Table No.14	(3,5-dinitrophenyl)methyl decanoate (27).
Table No.15	(3,5-dinitrophenyl)methyl 4-(trifluoromethyl)benzoate (28).
Table No.16	5-fluoro-heptanenitrile (29).
Table No.17	6-fluoro-heptanenitrile (30).
Table No.18	7-fluoro-heptanenitrile (31).
Table No.19	5-fluoro-octanenitrile (32).
Table No.20	6-fluoro-octanenitrile (33).
Table No.21	7-fluoro-octanenitrile (34).
Table No.22	2,5,7,10-tetraoxabicyclo[4.4.0]decane (35).
Table No.23	2-fluoro-5-(3-fluorooxepan-2-yloxy)pentanal (36).
Table No.24	3-fluoro-2-(3-fluorooxolan-2-yloxy)oxolane (37).
Table No.25	3-fluoro-2-(3-fluoroperhydro-2H-pyran-2-yloxy)perhydro-2H-pyran (38).

Table No.1 3-Fluoro-2-heptanone (14)

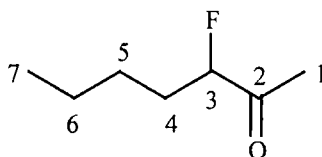

Chemical shifts (ppm)	Multiplicity	Coupling Constants (Hz)	Relative Intensity	Assignment
¹⁹ F				
-189.94	m	-	1F	-
¹³ C				
208.6	d	² J _{CF} 25.0		C-2
95.5	d	¹ J _{CF} 183.0		C-3
31.5	d	² J _{CF} 21		C-4
26.5	d	³ J _{CF} 3		C-5
25.9	s	-		C-1
22.3	s	-		C-6
13.8	s	-		C-7
¹ H				
0.85	m	-	3H	CH ₃ (H-7)
1.31	m	-	4H	H-5, H-6
1.68	m	-	2H	H-2
2.19	m	-	3H	CH ₃ (H-1)
4.65	m	-	1H	H-3

Table No.2 3-Fluoro-2-octanone (15)

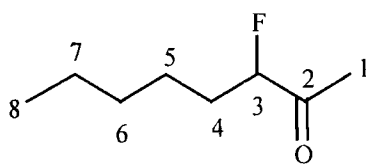

Chemical shifts (ppm)	Multiplicity	Coupling Constants (Hz)	Relative Intensity	Assignment
¹⁹ F				
-189.96	m	-	1F	-
¹³ C				
208.8	d	² J _{CF} 25.0		C-2
96.0	d	¹ J _{CF} 185.0		C-3
31.8	d	² J _{CF} 21		C-4
31.3	s	-		C-6
25.9	s	-		C-1
24.1	d	³ J _{CF} 3		C-5
22.4	s	-		C-7
13.9	s	-		C-8
¹ H				
0.89	m	-	3H	CH ₃ (H-8)
1.31	m	-	4H	H-6, H-7
1.39	m	-	2H	H-5
1.80	m	-	2H	H-4
2.25	m	-	3H	CH ₃ (H-1)
4.65	m	-	1H	H-3

Table No.3 3-Fluoro-hexan-2,5-dione (16)

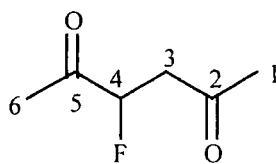

Chemical shifts (ppm)	Multiplicity	Coupling Constants (Hz)	Relative Intensity	Assignment
¹⁹ F				
-189.88	dtq	² J _{FH} 48.1, ³ J _{FH} 24.6, ⁴ J _{FH} 4.7	1F	-
¹³ C				
207.3	d	² J _{CF} 25.2		C-5
202.9	s	-		C-2
90.9	d	¹ J _{CF} 183.8		C-4
44.8	d	² J _{CF} 21.4		C-3
29.6	s	-		C-6
25.6	s	-		C-1
¹ H				
2.19	s	-	3H	CH ₃ (H-5)
2.35	s	-	3H	CH ₃ (H-1)
3.09	dd	³ J _{HF} 25, ³ J _{HH} 5	2H	H-3
4.86	dt	² J _{HF} 48, ³ J _{HH} 5	1H	H-4

Table No.4 Hex-3-ene-2,5-dione (17)

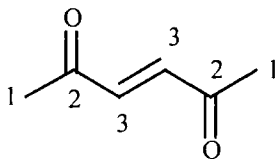

Chemical shifts (ppm)	Multiplicity	Coupling Constants (Hz)	Relative Intensity	Assignment
¹³ C				
202.9	s			C-2, C-5
137.5	s			C-3, C-4
27.5	s			C-1, C-6
¹ H				
2.16	s		6H	CH ₃ (H-1), CH ₃ (H-6)
6.63	s		2H	H-3, H-4

Table No.5 2-Fluoro-cyclopentanone (18)

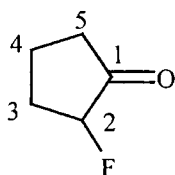

Chemical shifts (ppm)	Multiplicity	Coupling Constants (Hz)	Relative Intensity	Assignment
¹⁹ F				
-195.77	dm	¹ J _{FH} 52	1F	-
¹³ C				
211.9	d	² J _{CF} 13.4		C-1
91.2	d	¹ J _{CF} 190.4		C-2
33.9	d	¹ J _{CF} 1		C-5
28.7	d	² J _{CF} 17.6		C-3
15.7	d	³ J _{CF} 8.1		C-4
¹ H				
1.6-2.4	m		6H	H-3, H-4, H-5
4.72	ddm	² J _{HF} 50.5, ³ J _{HH} 9	1H	H-2

Table No.6 2-Fluoro-cyclohexanone (19)

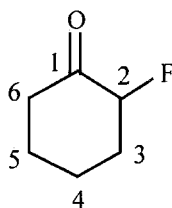

Chemical shifts (ppm)	Multiplicity	Coupling Constants (Hz)	Relative Intensity	Assignment
¹⁹ F				
-188.71	dm	¹ J _{FH} 48	1F	-
¹³ C				
205.6	d	² J _{CF} 14.5		C-1
92.6	d	¹ J _{CF} 189.0		C-2
40.1	s	-		C-6
34.1	d	² J _{CF} 18.7		C-3
26.8	s	-		C-5
22.6	d	³ J _{CF} 9.4		C-4
¹ H				
1.3-1.7	m		6H	H-3, H-4, H-5
2.24	m		2H	H-6
4.74	ddm	² J _{HF} 49.2, ³ J _{HH} 10.2	1H	H-2

Table No.7 2-Fluoro-cycloheptanone (20)

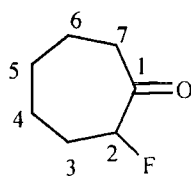

Chemical shifts (ppm)	Multiplicity	Coupling Constants (Hz)	Relative Intensity	Assignment
¹⁹ F				
-184.57	ddm	¹ J _{FH} 48.3, ³ J _{FH} 24.6	1F	-
¹³ C				
208.5	d	² J _{CF} 18.3		C-1
95.2	d	¹ J _{CF} 184.0		C-2
39.8	s	-		C-7
31.1	d	² J _{CF} 21		C-3
28.1	s	-		C-5
24.9	d	³ J _{CF} 6.9		C-4
22.9	s	-		C-6
¹ H				
1.4-2.0	m		8H	H-3, H-4, H-5, H-6
2.24	m		2H	H-7
4.74	ddm	² J _{HF} 49.0, ³ J _{HH} 8, ⁴ J _{HH} 3.5	1H	H-2

Table No.8 5-Fluoro-2-heptanone (21)

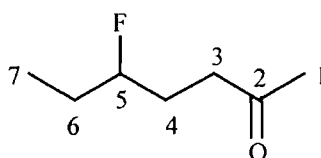

Chemical shifts (ppm)	Multiplicity	Coupling Constants (Hz)	Relative Intensity	Assignment
¹⁹ F				
-183.82	dm	² J _{FH} 51	1F	-
¹³ C				
208.2	s	-		C-2
94.8	d	¹ J _{CF} 166.5		C-5
38.9	d	³ J _{CF} 3.4		C-3
36.1	d	² J _{CF} 20.5		C-4
30.0	s	-		C-1
28.2	d	² J _{CF} 20.9		C-6
9.31	d	³ J _{CF} 5.7		C-7
¹ H				
0.9	t	³ J _{HH} 7.6	3H	CH ₃ (H-7)
1.58	m	-	4H	H-4, H-6
2.09	m	-	3H	CH ₃ (H-1)
2.47	tm	³ J _{HH} 6.8	2H	H-3
4.39	dm	² J _{HF} 49.6	1H	H-5

Table No.9 6-Fluoro-2-heptanone (22)

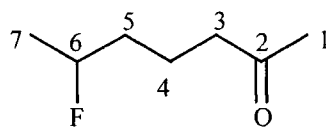

Chemical shifts (ppm)	Multiplicity	Coupling Constants (Hz)	Relative Intensity	Assignment
¹⁹ F				
-173.19	dm	² J _{HF} 48	1F	-
¹³ C				
208.6	s	-		C-2
90.7	d	¹ J _{CF} 164.0		C-6
43.2	s	-		C-3
29.9	s	-		C-1
28.5	d	² J _{CF} 20.9		C-5
20.9	d	² J _{CF} 22.3		C-7
19.4	d	³ J _{CF} 4.5		C-4
¹ H				
1.26	dd	³ J _{HF} 24.4	3H	CH ₃ (H-7)
1.58	m	-	4H	H-4, H-5
2.09	m	-	3H	CH ₃ (H-1)
2.41	tm	³ J _{HH} 8	2H	H-3
4.71	dt	² J _{HF} 48, ³ J _{HH} 4.8, ³ J _{HH} 5.8	1H	H-6

Table No.10 3-Fluoro-cyclohexanone (23)

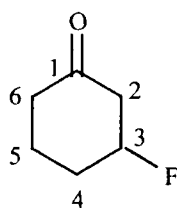

Chemical shifts (ppm)	Multiplicity	Coupling Constants (Hz)	Relative Intensity	Assignment
¹⁹ F				
-186.94	dm	² J _{FH} 46	1F	-
¹³ C				
209.9	s	-		C-1
87.2	d	¹ J _{CF} 169		C-3
38.0	s	-		C-6
31.04	d	² J _{CF} 21.0		C-2
26.9	d	² J _{CF} 12.0		C-5
22.7	d	² J _{CF} 23.0		C-4
¹ H				
2.0-.2.4	m	-	8H	H-2, H-4, H-5, H-6
4.45	dm	² J _{HF} 45.6	1H	H-3

Table No.11 3-Fluoro-cycloheptanone (24)

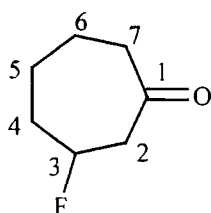

Chemical shifts (ppm)	Multiplicity	Coupling Constants (Hz)	Relative Intensity	Assignment
¹⁹ F				
-176.52	dt	² J _{FH} 46.0, ³ J _{FH} 27.0, ⁴ J _{FH} 9	1F	-
¹³ C				
209.4	d	³ J _{CF} 8.6		C-1
88.3	d	¹ J _{CF} 170.0		C-3
48.9	d	² J _{CF} 23.0		C-2
42.9	d	² J _{CF} 20.9		C-7
35.4	d	³ J _{CF} 7.8		C-4
23.4	s	-		C-5
23.2	s	-		C-6
¹ H				
1.2-3.0	m	-	12H	H-1, H-2, H-4, H-5, H-6, H-7.
4.68	d	² J _{HF} 45.5	1H	H-3

Table No.12 4-Fluoro-cycloheptanone (25)

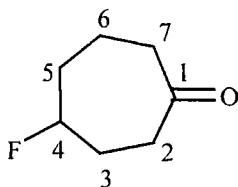

Chemical shifts (ppm)	Multiplicity	Coupling Constants (Hz)	Relative Intensity	Assignment
¹⁹ F				
-174.77	dt	² J _{FH} 52, ³ J _{FH} 29, ⁴ J _{FH} 7	1F	-
¹³ C				
213.2	s	-		C-1
91.4	d	¹ J _{CF} 169.0		C-4
44.0	s	-		C-7
36.1	d	³ J _{CF} 8.6		C-2
35.0	d	² J _{CF} 20.9		C-3
29.2	d	² J _{CF} 22.4		C-5
17.2	d	³ J _{CF} 7.8		C-6
¹ H				
1.2-3.0	m	-	12H	H-1, H-2, H-3, H-5, H-6, H-7.
4.99	dm	² J _{HF} 49.0	1H	H-4

Table No.13 (3,5-dinitrophenyl)methyl heptanoate (26)

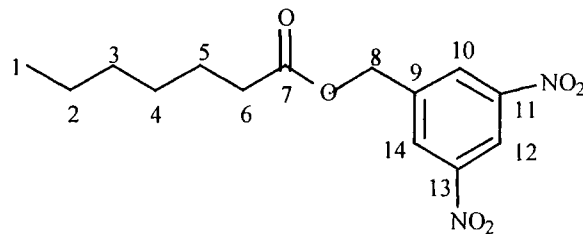

Chemical shifts (ppm)	Multiplicity	Coupling Constants (Hz)	Relative Intensity	Assignment
¹³ C				
173.1	s			C-7
148.6	s			C-11, C-13
140.8	s			C-9
127.7	s			C-10, C-14
118.4	s			C-12
63.5	s			C-8
33.9	s			C-6
31.4	s			C-5
28.7	s			C-4
24.7	s			C-3
22.4	s			C-2
13.9	s			C-1
¹ H				
0.87	t	³ J _{HH} 7.2	3H	CH ₃ (H-1)
1.29	m	-	6H	H-2, H-3, H-4
1.66	m	-	2H	H-5
2.44	t	³ J _{HH} 7.6	2H	H-6
5.29	s	-	2H	H-8
8.54	m	-	2H	H-10, H-14
8.99	m	-	1H	H-12

Table No.14 (3,5-dinitrophenyl)methyl decanoate (27)

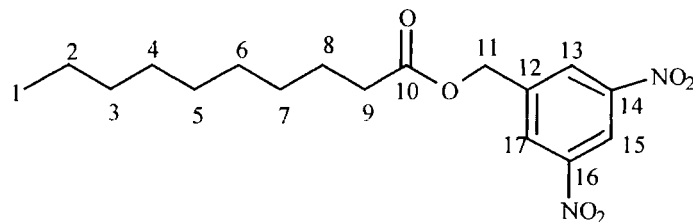

Chemical shifts (ppm)	Multiplicity	Coupling Constants (Hz)	Relative Intensity	Assignment
¹³ C				
173.4	s			C-10
148.9	s			C-13, C-15
141.1	s			C-12
127.9	s			C-13, C-17
118.6	s			C-15
63.8	s			C-11
34.2	s			C-9
32.1	s			C-8
29.6	s			C-7
29.5	s			C-6
29.4	s			C-5
29.3	s			C-4
25.1	s			C-3
22.9	s			C-2
14.0	s			C-1
¹ H				
0.80	t	³ J _{HH} 7.0	3H	CH ₃ (H-1)
1.21	m	-	12H	H-2, H-3, H-4, H-5, H-6, H-7.
1.60	m	-	2H	H-8
2.37	t	³ J _{HH} 6.0	2H	H-9
5.23	s	-	2H	H-11

8.47	m	-	2H	H-13, H-17
8.93	m	-	1H	H-15

Table No.15 (3,5-dinitrophenyl)methyl 4-(trifluoromethyl)benzoate (28)

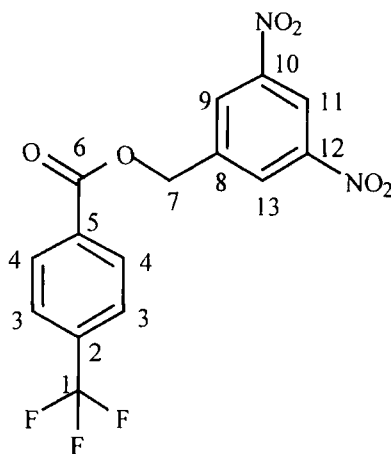

Chemical shifts (ppm)	Multiplicity	Coupling Constants (Hz)	Relative Intensity	Assignment
¹³ C				
164.8	s	-		C-6
148.7	s	-		C-10, C-12
140.0	s	-		C-8
134.8	q	² J _{CF} 33.0		C-2
132.0	s	-		C-5
130.3	s	-		C-4
128.1	s	-		C-9, C-13
125.8	q	³ J _{CF} 4.0		C-3
123.4	q	¹ J _{CF} 271.0		C-1
118.8	s	-		C-11
64.7	s	-		C-7
¹ H				
5.58	s	-	2H	H-7
7.76	d	³ J _{HH} 8.4	2H	H-3
8.21	d	³ J _{HH} 8.0	2H	H-4
8.65	d	⁴ J _{HH} 2.0	2H	H-9, H-13
9.05	d	⁴ J _{HH} 2.0	1H	H-11

Table No.16 5-fluoro-heptanenitrile (29)

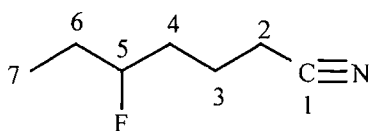

Chemical shifts (ppm)	Multiplicity	Coupling Constants (Hz)	Relative Intensity	Assignment
¹⁹ F -183.23	dm	² J _{FH} 46.0	1F	-
¹³ C 119.6	s	-		C-1
94.5	d	¹ J _{CF} 168.0		C-5
33.3	d	² J _{CF} 21.0		C-4
29.9	d	² J _{CF} 20.0		C-6
24.4	d	³ J _{CF} 5.0		C-3
16.9	s	-		C-2
9.1	d	³ J _{CF} 6.0		C-7
¹ H 0.95	t	³ J _{HH} 7.2	3H	CH ₃ (H-7)
1.4-1.8	m	-	6H	H-3, H-4, H-6
2.39	td	³ J _{HH} 6.0, ⁵ J _{HF} 2.0	2H	H-2
4.39	dm	² J _{HF} 49.0	1H	H-5

Table No.17 6-fluoro-heptanenitrile (30)

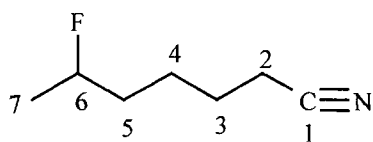

Chemical shifts (ppm)	Multiplicity	Coupling Constants (Hz)	Relative Intensity	Assignment
¹⁹ F -173.63	dm	² J _{FH} 49.0	1F	-
¹³ C 119.5	s	-		C-1
90.3	d	¹ J _{CF} 164.0		C-6
35.8	d	² J _{CF} 21.0		C-5
25.0	s	-		C-3
24.2	d	³ J _{CF} 5.0		C-4
20.8	d	² J _{CF} 23.0		C-7
16.9	s	-		C-2
¹ H 1.29	dd	³ J _{HH} 6.0, ³ J _{HF} 24.0	3H	CH ₃ (H-7)
1.4-1.8	m	-	6H	H-3, H-4, H-5
2.33	t	³ J _{HH} 7.0	2H	H-2
4.62	dm	² J _{HF} 49.0	1H	H-6

Table No.18 7-fluoro-heptanenitrile (31)

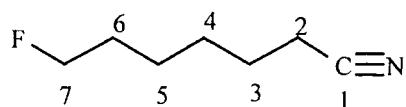

Chemical shifts (ppm)	Multiplicity	Coupling Constants (Hz)	Relative Intensity	Assignment
¹⁹ F -219.10	tt	² J _{FH} 48.0, ³ J _{FH} 26.0	1F	-
¹³ C 119.4	s	-		C-1
83.7	d	¹ J _{CF} 164.0		C-7
28.1	s	-		C-4
27.9	d	² J _{CF} 21.0		C-6
25.1	s	-		C-3
21.3	d	³ J _{CF} 4.0		C-5
16.8	s	-		C-2
¹ H 1.4-1.8	m	-	8H	H-3, H-4, H-5, H-6
2.34	t	³ J _{HH} 7.0	2H	H-2
4.44	dt	² J _{HF} 47.0, ³ J _{HH} 6.0	2H	H-7

Table No.19 5-fluoro-octanenitrile (32)

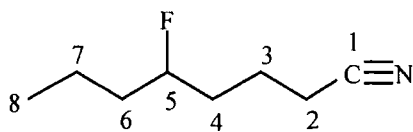

Chemical shifts (ppm)	Multiplicity	Coupling Constants (Hz)	Relative Intensity	Assignment
¹⁹ F -182.28	dt	² J _{FH} 47.9, ³ J _{FH} 24.0, ⁴ J _{FH} 9.0	1F	-
¹³ C 119.3	s	-		C-1
94.7	d	¹ J _{CF} 167.0		C-5
33.5	d	² J _{CF} 21.4		C-4
27.9	d	² J _{CF} 21.3		C-6
24.9	s	-		C-3
24.1	d	³ J _{CF} 4.2		C-7
16.6	s	-		C-2
13.4	s	-		C-8
¹ H 0.85	tm	³ J _{HH} 6.0	3H	H-8
1.3-1.6	m	-	2H	H-2
2.2-2.4	m	² J _{HH} 47.0, ³ J _{HH} 6.0	8H	H-3, H-4, H-6, H-7
4.38	dm	² J _{HF} 46.7	1H	H-5

Table No.21 7-fluoro-octanenitrile (34)

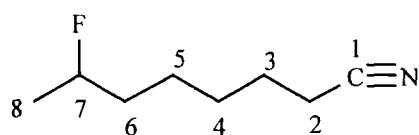

Chemical shifts (ppm)	Multiplicity	Coupling Constants (Hz)	Relative Intensity	Assignment
¹⁹ F -173.27	dtm	² J _{FH} 48.1, ³ J _{FH} 18.0,	1F	-
¹³ C 119.1	s	-		C-1
90.2	d	-		C-7
36.2	d	¹ J _{CF} 164.0		C-6
28.1	s	² J _{CF} 20.6		C-3
23.9	d	-		C-5
22.3	s	³ J _{CF} 4.6		C-4
20.5	d	-		C-8
16.6	s	² J _{CF} 23.0		C-2
		-		
¹ H 1.13-1.17	m	-	3H	H-8
2.2-2.4	m	-	10H	H-2, H-3, H-4, H-5, H-6.
4.49	dm	² J _{HF} 51.7	1H	H-7

Table No.22 3-fluoro-2-(3-fluorooxolan-2-yloxy)oxolane (35)

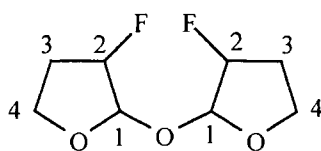

Chemical shifts (ppm)	Multiplicity	Coupling Constants (Hz)	Relative Intensity	Assignment
¹⁹ F -189.94	dm	² J _{FH} 53.0	2F	-
¹³ C 100.9	d	² J _{CF} 33.0		C-1
95.3	d	¹ J _{CF} 177.0		C-2
66.7	s	-		C-4
30.1	d	² J _{CF} 21.0		C-3
¹ H 2.02-2.3	m	-	4H	H-4
3.90-4.14	m	-	4H	H-3
4.93	ddd	² J _{HF} 52.4, ³ J _{HH} 4.8, ⁴ J _{HH} 0.8	2H	H-2
5.40	d	³ J _{HF} 10.0	2H	H-1

**Table No.23 3-fluoro-2-(3-fluoroperhydro-2H-pyran-2-yloxy)perhydro-2H-pyran
(36)**

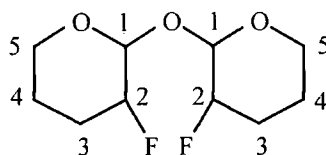

Chemical shifts (ppm)	Multiplicity	Coupling Constants (Hz)	Relative Intensity	Assignment
¹⁹ F -190.33	dm	² J _{FH} 48.0	2F	-
¹³ C 93.2	d	² J _{CF} 29.0		C-1
87.8	d	¹ J _{CF} 173.0		C-2
62.8	s	-		C-5
25.3	d	² J _{CF} 19.0		C-3
20.8	d	³ J _{CF} 3.0		C-4
¹ H 1.4-2.2	m	-	8H	H-3, H-4
3.56-3.98	m	-	4H	H-5
4.36	ddd	² J _{HF} 48.0, ³ J _{HH} 6.5, ⁴ J _{HH} 3.8	2H	H-2
4.96	m	-	1H	H-1

Table No.24 2,5,7,10-tetraoxabicyclo[4.4.0]decane (37)

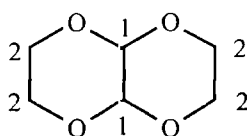

Chemical shifts (ppm)	Multiplicity	Coupling Constants (Hz)	Relative Intensity	Assignment
¹³ C				
91.7	s	-	-	C-1
62.5	s	-	-	C-2
¹ H				
3.67 and 4.03	m	-	8H	H-2
4.68	s	-	2H	H-1

Table No.25 2-fluoro-5-(3-fluorooxepan-2-yloxy)pentanal (38)

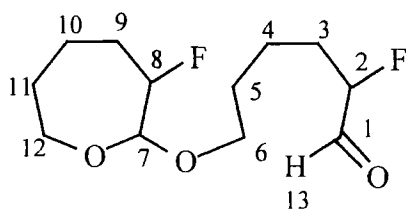

Chemical shifts (ppm)	Multiplicity	Coupling Constants (Hz)	Relative Intensity	Assignment
¹⁹ F				
-180.70	m	-	1F	CHF ₂ -CHO
-200.18	dm	² J _{FH} 51.0	1F	CHF ₈
¹³ C				
200.3	d	² J _{CF} 33.0		C-1
104.3	d	² J _{CF} 35.0		C-7
104.2	d	² J _{CF} 35.0		C-7
96.4	d	¹ J _{CF} 171.0		C-8
94.9	d	¹ J _{CF} 178.0		C-2
67.4	s	-		C-6
64.7	s	-		C-12
30.7	d	² J _{CF} 21.0		C-9
30.2	s	-		C-11
30.1	d	² J _{CF} 18.0		C-3
30.06	d	² J _{CF} 16.0		C-3
29.04	s	-		C-5
22.9	d	² J _{CF} 21.0		C-10
21.1	2d	³ J _{CF} 3.0		C-4
¹ H				
1.4-2.2	m	-	12H	H-3, H-4, H-5, H-9, H-10, H-11.
3.47	dt	² J _{HH} 10.0, ³ J _{HH} 6.0	1H	H-6
3.57	dt	² J _{HH} 12.0, ³ J _{HH} 4.0	1H	H-12

3.75	m	-	2H	H-6, H-12
4.51	dm	$^2J_{HF}$ 48.0	1H	H-8
4.57	d	$^3J_{HH}$ 6.0	1H	H-7
4.60	d	$^3J_{HF}$ 7.0	1H	H-7
4.77	ddd	$^2J_{HF}$ 49.6, $^3J_{HH}$ 8.0, $^3J_{HH}$ 5.0.	1H	H-2
9.77	d	$^3J_{HF}$ 6.0	1H	H-13

Appendix Two: Crystal Data of (37)

Table 1. Crystal data and structure refinement for 02srv079.

Identification code	s079	
Empirical formula	$C_6 H_{10} O_4$	
Formula weight	146.14	
Temperature	120(2) K	
Wavelength	0.71073 Å	
Crystal system	Monoclinic	
Space group	C 2/c	
Unit cell dimensions	$a = 15.7692(7)$ Å	$\alpha = 90^\circ$.
	$b = 7.0192(3)$ Å	$\beta = 92.69(1)^\circ$.
	$c = 11.5111(5)$ Å	$\gamma = 90^\circ$.
Volume	$1272.7(1)$ Å ³	
Z	8	
Density (calculated)	1.525 Mg/m ³	
Absorption coefficient	0.129 mm ⁻¹	
F(000)	624	
Crystal size	0.42 x 0.05 x 0.03 mm ³	
Theta range for data collection	2.59 to 28.99°.	
Index ranges	$-20 \leq h \leq 21, -9 \leq k \leq 8, -15 \leq l \leq 15$	
Reflections collected	4933	
Independent reflections	1690 [R(int) = 0.0565]	
Completeness to theta = 28.99°	99.8 %	
Absorption correction	None	
Max. and min. transmission	0.9961 and 0.9478	
Refinement method	Full-matrix least-squares on F ²	
Data / restraints / parameters	1690 / 0 / 131	
Goodness-of-fit on F ²	0.940	
Final R indices [I > 2σ(I)]	R1 = 0.0371, wR2 = 0.0896	
R indices (all data)	R1 = 0.0629, wR2 = 0.0993	
Largest diff. peak and hole	0.350 and -0.221 e.Å ⁻³	

Table 2. Atomic coordinates ($\times 10^4$) and equivalent isotropic displacement parameters ($\text{\AA}^2 \times 10^3$) for 02srv079. $U(\text{eq})$ is defined as one third of the trace of the orthogonalized U^{ij} tensor.

Atom	x	y	z	$U(\text{eq})$
O(1)	3347(1)	668(1)	8774(1)	21(1)
O(4)	4364(1)	2419(1)	10556(1)	23(1)
O(5)	3763(1)	4681(1)	9356(1)	21(1)
O(8)	4016(1)	2373(1)	7398(1)	22(1)
C(2)	3415(1)	-124(2)	9927(1)	24(1)
C(3)	3589(1)	1436(2)	10801(1)	22(1)
C(6)	3726(1)	5477(2)	8201(1)	24(1)
C(7)	3443(1)	3978(2)	7334(1)	22(1)
C(9)	4115(1)	1612(2)	8518(1)	19(1)
C(10)	4350(1)	3148(2)	9422(1)	19(1)

Table 3. Bond lengths [\AA] and angles [$^\circ$] for 02srv079.

O(1)-C(9)	1.423(2)	O(5)-C(10)	1.420(2)	C(2)-C(3)	1.504(2)
O(1)-C(2)	1.439(2)	O(5)-C(6)	1.440(2)	C(6)-C(7)	1.504(2)
O(4)-C(10)	1.401(2)	O(8)-C(9)	1.398(2)	C(9)-C(10)	1.532(2)
O(4)-C(3)	1.443(2)	O(8)-C(7)	1.444(2)		

C(9)-O(1)-C(2)	110.1(1)	O(8)-C(7)-C(6)	110.3(1)
C(10)-O(4)-C(3)	112.4(1)	O(8)-C(9)-O(1)	108.0(1)
C(10)-O(5)-C(6)	110.0(1)	O(8)-C(9)-C(10)	111.8(1)
C(9)-O(8)-C(7)	112.8(1)	O(1)-C(9)-C(10)	111.7(1)
O(1)-C(2)-C(3)	109.8(1)	O(4)-C(10)-O(5)	107.9(1)
O(4)-C(3)-C(2)	110.3(1)	O(4)-C(10)-C(9)	111.6(1)
O(5)-C(6)-C(7)	109.8(1)	O(5)-C(10)-C(9)	111.1(1)

Table 4. Anisotropic displacement parameters ($\text{\AA}^2 \times 10^3$) for 02srv079. The anisotropic displacement factor exponent takes the form: $-2\pi^2 [h^2 a^{*2} U^{11} + \dots + 2 h k a^* b^* U^{12}]$

Atom	U^{11}	U^{22}	U^{33}	U^{23}	U^{13}	U^{12}
O(1)	24(1)	20(1)	19(1)	1(1)	-1(1)	-3(1)
O(4)	27(1)	24(1)	17(1)	0(1)	-4(1)	0(1)
O(5)	29(1)	18(1)	17(1)	0(1)	2(1)	3(1)
O(8)	26(1)	23(1)	16(1)	-2(1)	1(1)	2(1)
C(2)	28(1)	21(1)	21(1)	3(1)	1(1)	0(1)
C(3)	28(1)	21(1)	18(1)	2(1)	3(1)	3(1)
C(6)	32(1)	20(1)	20(1)	3(1)	3(1)	2(1)
C(7)	23(1)	25(1)	19(1)	2(1)	-1(1)	1(1)
C(9)	20(1)	19(1)	18(1)	-1(1)	1(1)	1(1)
C(10)	20(1)	20(1)	17(1)	-2(1)	-1(1)	0(1)

Table 5. Hydrogen coordinates ($\times 10^4$) and isotropic displacement parameters ($\text{\AA}^2 \times 10^3$) for 02srv079.

Atom	x	y	z	U(eq)
H(21)	2864(10)	-720(20)	10050(13)	24(4)
H(22)	3874(9)	-1100(20)	9983(13)	22(4)
H(31)	3116(10)	2340(20)	10772(13)	18(4)
H(32)	3662(9)	910(20)	11576(14)	21(4)
H(61)	3310(10)	6530(20)	8196(14)	27(4)
H(62)	4293(10)	6030(20)	8032(14)	25(4)
H(71)	2862(9)	3550(20)	7489(13)	21(4)
H(72)	3478(10)	4410(20)	6536(15)	26(4)
H(9)	4596(9)	670(20)	8476(12)	13(3)
H(10)	4940(9)	3640(20)	9290(12)	13(3)

Table 6. Torsion angles [$^\circ$] for 02srv079.

C(9)-O(1)-C(2)-C(3)	59.60(14)	C(2)-O(1)-C(9)-C(10)	-56.16(14)
C(10)-O(4)-C(3)-C(2)	56.11(15)	C(3)-O(4)-C(10)-O(5)	69.98(14)
O(1)-C(2)-C(3)-O(4)	-58.89(15)	C(3)-O(4)-C(10)-C(9)	-52.41(14)
C(10)-O(5)-C(6)-C(7)	60.31(14)	C(6)-O(5)-C(10)-O(4)	-179.89(10)
C(9)-O(8)-C(7)-C(6)	54.94(14)	C(6)-O(5)-C(10)-C(9)	-57.22(14)
O(5)-C(6)-C(7)-O(8)	-58.17(15)	O(8)-C(9)-C(10)-O(4)	173.89(10)
C(7)-O(8)-C(9)-O(1)	71.21(13)	O(1)-C(9)-C(10)-O(4)	52.81(14)
C(7)-O(8)-C(9)-C(10)	-51.97(14)	O(8)-C(9)-C(10)-O(5)	53.35(15)
C(2)-O(1)-C(9)-O(8)	-179.39(10)	O(1)-C(9)-C(10)-O(5)	-67.74(14)

References

1. G. Sandford, *Phil. Trans. R. Soc. Lond. A* (2000) **358**, 455-471.
2. H. Meinert, *Fluorochemie*; Akademie-Verlag, Berlin, 1979.
3. W. G. M. Jones, *Organofluorine Compounds*, ed. R. E. Banks, Ellis Horwood, Chichester, Halsted Press, 1982, p.45.
4. D. F. Halpern, *Organofluorine Compounds in Medicinal Chemistry and Biomedical Applications*, ed. R. Filler, Y. Kobayashi and L. M. Yagupolskii, Elsevier, Amsterdam, 1993.
5. R. E. Banks, *J. Fluorine. Chem.*, 1998, **87**, 1-17.
6. N. N. Greenwood and A. Earnshaw, *Chemistry of the Elements*, Pergamon Press, Oxford, 1984, p.934.
7. J. E. Huehee, *Inorganic Chemistry*, Harper Collins, New York, 1983.
8. H. Moissan, *Compt. Rend.*, 1886, **102**, 1543.
9. H. Moissan, *Ann. Chim. Phys.*, 1891, **19**, 272.
10. F. Swarts, *Bull. Acad. Roy. Belg.*, 1892, **24**, 474.
11. W. Bockemuller, *Liebigs Ann. Chem.*, 1933, **506**, 20.
12. L. A. Bigelow, J. H. Pearson, L. B. Cook and W. T. Miller, *J. Am. Chem. Soc.*, 1933, **55**, 4614.
13. L. A. Bigelow and J. H. Pearson, *J. Am. Chem. Soc.*, 1934, **56**, 2773.
14. K. Fredenhagen and G. Cadenbach, *Ber.*, 1934, **67**, 928.
15. L. A. Bigelow, J. D. Calfee and W. T. Miller, *J. Am. Chem. Soc.*, 1937, **59**, 198.
16. J. H. Simons, *J. Am. Chem. Soc.*, 1937, **59**, 1407.
17. R. E. Banks, *Fluorine, the first hundred years*, Elsevier, New York, 1986, p.3.
18. F. Steel and O. Detmer, *Z. Anorg. u. Allgem. Chem.*, 1959, **301**, 113.
19. K. O. Christe, *Inorganic Chemistry*, 1986, **25**, 3721.
20. W. T. Miller and A. L. Dittman, *J. Am. Chem. Soc.*, 1956, **78**, 2793.
21. W. T. Miller, S. D. Koch and F. W. McLafferty, *J. Am. Chem. Soc.*, 1956, **78**, 4992.
22. W. T. Miller and S. D. Koch, *J. Am. Chem. Soc.*, 1957, **79**, 3084.
23. P. C. Anson and J. M. Tedder, *J. Chem. Soc.*, 1957, 4390.

24. G. Sandford and J. Hutchinson, Elemental Fluorine in Organic Chemistry, *Topics in Current Chemistry*, 1997, 193, p.3.
25. G. E. Gerhardt and R. J. Lagow, *J. Org. Chem.*, 1978, **43**, 4505.
26. G. E. Gerhardt and R. J. Lagow, *J. Am. Chem. Soc.*, 1977, 259.
27. N. J. Maraschin, B. D. Catsikis, L. H. Davis, G. Jarvinen and R. J. Lagow, *J. A. Chem. Soc.*, 1975, **97**, 513.
28. J. L. Adcock, R. A. Beh and R. J. Lagow, *J. Org. Chem.*, 1975, **40**, 3271.
29. W. H. Lin, W. I. Bailey Jr. and R. J. Lagow, *Chem. Commun.*, 1985, 1350.
30. W. H. Lin and W. I. Bailey Jr., *Pure Appl. Chem.*, 1988, **60**, 473.
31. W. H. Lin, W. Clark and R. J. Lagow, *J. Org. Chem.*, 1989, **54**, 1990.
32. R. F. Merritt and F. A. Johnson, *J. Org. Chem.*, 1966, **31**, 1859.
33. R. F. Merritt, *J. Org. Chem.*, 1966, **31**, 3871.
34. R. F. Merritt and T. E. Stevens, *J. Am. Chem. Soc.*, 1966, **88**, 1822.
35. R. F. Merritt, *J. Am. Chem. Soc.*, 1967, **89**, 1822.
36. C. Gal and S. Rozen, *Tetrahedron Lett.*, 1984, **25**, 449.
37. S. Rozen, C. Gal and Y. Faust, *J. Am. Chem. Soc.*, 1980, **102**, 6860.
38. C. Gal and S. Rozen, *Tetrahedron Lett.*, 1985, **26**, 2793.
39. S. Rozen, C. Gal and G. Ben-Shushan, *J. Org. Chem.*, 1980, **21**, 5067.
40. C. Gal and S. Rozen, *J. Fluorine Chem.*, 1982, **20**, 689.
41. C. Gal and S. Rozen, *J. Fluorine Chem.*, 1985, **27**, 143.
42. C. Gal and S. Rozen, *J. Org. Chem.*, 1987, **52**, 2769-2779
43. S. T. Purrington and B. S. Kagen, *Chem. Rev.*, 1986, **86**, 997-1018.
44. R. D. Chambers, M. Parsons, G. Sandford and R. Bowden, *Chem. Commun.*, 2000, 959-960.
45. V. Grakauskas, *J. Org. Chem.*, 1970, **35**, 723.
46. S. Misaki, *J. Fluorine Chem.*, 1981, **17**, 159.
47. R. D. Chambers, G. Sandford and J. Hutchinson, *J. Fluorine Chem.*, 1999, 63-73.
48. R. D. Chambers, C. J. Skinner, J. Thomson and J. Hutchinson, *J. Chem. Soc. Chem. Commun.*, 1995, 17.
49. R. D. Chambers, C. J. Skinner, J. Thomson and J. Hutchinson, *J. Chem. Soc. Chem. Commun.*, 1996, 605.
50. C. J. Skinner, Ph.D Thesis, Univ. of Durham, 1994.

51. T. Tsushima, K. Kawada, T. Tsuji and S. Misaki, *J. Org. Chem.*, 1982, **47**, 1107-1110.
52. S. T. Purrington, N. V. Lazaridis and C. L. Bumgardner, *Tetrahedron Lett.* 1986, **27**, 2715-2716.
53. S. Rozen and O. J. Lerman, *J. Am. Chem. Soc.*, 1979, **101**, 2782.
54. R. D. Chambers, M. P. Greenhall and J. Hutchinson, *J. Chem. Soc. Chem. Commun.*, 1995, 21.
55. R. D. Chambers and J. Hutchinson, *J. Fluorine Chem.*, 1998, **92**, 45-52.
56. R. E. Banks, G. E. Williamson, *Chem. Ind. (London)*, 1964, 1864.
57. R. E. Banks, K. Mullen, W. J. Nicholson, C. Oppenheim, A. Prakash, *J. Chem. Soc., Perkin Trans. 1*, 1972, 1098.
58. R. E. Banks, M. G. Barlow, *Royal Society of Chemistry Specialist Periodical*, 1974, **2**, 206.
59. R. E. Banks, V. Murtagh, E. Tsiliopoulos, *J. Fluorine Chem.*, 1991, **52**, 389.
60. S. Rozen, *Chem. Rev.*, 1996, **96**, 1717.
61. M. A. Tuis, *Tetrahedron*, 1995, **51**, 6605-6634.
62. V. V. Bardin, Y. L. Yagupolskii, *New Fluorinating Agents in Organic Synthesis*, Berlin, Springer Verlag, 1989, 1-34.
63. S. T. Purrington, W. A. Jones, *J. Org. Chem.*, 1983, **48**, 761.
64. W. E. Barnette, *J. Am. Chem. Soc.*, 1984, **106**, 452.
65. T. Umemoto, K. Tomita, *Tetrahedron Lett.*, 1986, **27**, 3271.
66. T. Umemoto, K. Kawada, K. Tomita, *Tetrahedron Lett.*, 1986, **27**, 4465.
67. R. E. Banks, R. A. Du Boisson, E. Tsiliopoulos, *J. Fluorine Chem.*, 1986, **32**, 461.
68. D. D. DesMarteau, USP 4, 697, 011/1987.
69. R. E. Banks, S. N. Mohialdin-Khaffaf, G. S. Lal, I. Sharif, R. G. Syrvet, *J. Chem.Soc. Chem. Commun.*, 1992, 595.
70. R. E. Banks, M. K. Besheesh, S. N. Mohialdin-Khaffaf, I. Sharif, *J. Chem.Soc. Perkin Trans. 1*, 1996, 2069.
71. R. E. Banks, V. Murtagh, *Encyclopedia of Reagents for Organic Synthesis*, Chichester, WileyEurope, 1995, **2**, 1150-1153.
72. R. E. Banks, M. K. Besheesh, S. N. Mohialdin-Khaffaf, I. Sharif, *J. Fluorine Chem.*, 1996, **78**, 43.

73. R. E. Banks, USP 5, 086, 178/1992.
74. D. L. Illman, *Chem. Eng. News.*, 1993, **36**, 26.
75. G. P. Pez, Fluorine for pharmaceuticals, *Air Products Technology Impact Magazine*, 1993, **3**, 2-9.
76. M. Brunavs, C. P. Dell, M. W. Owton, *J. Fluorine Chem.*, 1994, **68**, 201.
77. P. G. Sammes, *Chem. Rev.*, 1976, **76**, 113.
78. P. Hermann, R. Freidlima, E. A. Skorova, *Organic Sulfur Chemistry*; Pergamon Press, Oxford, 1981.
79. E. T. Jarvi, J. R. McCarthy, S. Mehdi, D. P. Matthews, M. L. Edwards, N. J. Prakash, T. L. Bowlin, P. S. Sunkara, P. J. Bey, *J. Med. Chem.*, 1991, **34**, 647.
80. M. J. Zupan, *J. Fluorine Chem.*, 1976, **8**, 305.
81. T. Umemoto, G. Tomozawa, *Bull. Chem. Soc. Jpn.*, 1986, **59**, 3625.
82. R. E. Banks (Ed.), *Fluorine in Agriculture*, Paper 16, Fluorine Technology, Manchester, 1995.
83. R. E. Banks, N. J. Lawrence, A. L. Popplewell, *J. Chem. Soc. Chem. Commun.*, 1994, 343.
84. G. S. Lal, P. G. Pez, R. G. Syrvet, *Chem. Rev.*, 1996, **96**, 1737-1755.
85. S. D. R. Christie, *J. Chem. Soc. Perkin. Trans. 1*, 1998, 1577.
86. E. Differding, P. M. Bersier, *Tetrahedron*, 1992, **48**, 1595.
87. E. Differding, M. Wehrli, *Tetrahedron Lett.*, 1991, **32**, 3819.
88. E. Differding, G. Ruegg, *Tetrahedron Lett.*, 1991, **32**, 3815.
89. M. Zupan, P. Skulj, S. Stavber, *Chem. Lett.*, 1998, 641.
90. D. D. DesMarteau, Z. Q. Xu, M. Witz, *J. Org. Chem.*, 1992, **57**, 629.
91. T. Umemoto, S. Fukami, G. Tomizawa, K. Harasawa, K. Kawada, K. Tomita, *J. Am. Chem. Soc.*, 1990, **112**, 8563.
92. S. Stavber and M. Zupan, *Tetrahedron Lett.*, 1996, **37**, 3591-3594.
93. G. S. Lal, *J. Org. Chem.*, 1993, **58**, 2791-2796.
94. R. D. Chambers and J. Hutchinson, *J. Fluorine. Chem.*, 1998, **89**, 229-232.
95. H. O. Kalinowski, S. Berger and S. Braun, *Carbon-13 NMR Spectroscopy*, **1988**, 577-582.
96. Patai, *Chemistry of Enols*, Chichester, WileyEurope, p 348-349.
97. H. Kamaya, M. Sato and C. Kaneko, *Tetrahedron Lett.*, 1996, **38**, 587-590.
98. L. Hintermann and A. Togni, *Angew. Chem.*, 2000, **23**, 4559-4362.

99. M. I. Rodriguez-Franco, I. Dorronso, A. I. Hernandez-Higueras and G. Antequera, *Tetrahedron Lett.*, 2001, **42**, 863-865.
100. H. O. Kalinowski, S. Berger and S. Braun, *NMR Spectroscopy of the non-metallic Elements*, 1997, 415-482.
101. M. P. Doyle, J. L. Whitefleet and R. J. Bosch, *J. Org. Chem.*, 1979, **44**, 2923-2929.
102. Fuchs and al, *J. Chem. Soc. Perkin Trans. 2*, 1972, 357.

