

## Durham E-Theses

---

# *CROSSTALK BETWEEN THE ER STRESS PATHWAY AND OSMOTIC STRESS IN S. CEREVISIAE*

NARAYANAN, SIDDHARTH

### How to cite:

---

NARAYANAN, SIDDHARTH (2011) *CROSSTALK BETWEEN THE ER STRESS PATHWAY AND OSMOTIC STRESS IN S. CEREVISIAE*, Durham theses, Durham University. Available at Durham E-Theses Online: <http://etheses.dur.ac.uk/3435/>

### Use policy

---

The full-text may be used and/or reproduced, and given to third parties in any format or medium, without prior permission or charge, for personal research or study, educational, or not-for-profit purposes provided that:

- a full bibliographic reference is made to the original source
- a [link](#) is made to the metadata record in Durham E-Theses
- the full-text is not changed in any way

The full-text must not be sold in any format or medium without the formal permission of the copyright holders.

Please consult the [full Durham E-Theses policy](#) for further details.

**CROSSTALK BETWEEN THE ER STRESS PATHWAY AND OSMOTIC  
STRESS IN *S. CEREVISIAE***

**Siddharth Narayanan**

**This thesis is submitted as part of the requirements for the award of  
Degree of Doctor of Philosophy**

**School of Biological and Biomedical Sciences  
Durham University**

**December 2011**

## ABSTRACT

In *Saccharomyces cerevisiae*, the general stress response (GSR) protects cells from diverse stress conditions such as osmotic stress and heat stress, while the Unfolded Protein Response (UPR) is a protein folding stress signalling pathway which maintains homeostasis of the endoplasmic reticulum (ER). A mechanism of how and if at all the UPR integrates with other pathways is largely unknown. The focus of this thesis was to determine whether essential components of the UPR like the bZIP transcription factor Hac1p and the Rpd3p-Sin3p histone deacetylase integrated within osmotic stress and to identify a possible mechanism of such an integration event.

Data from this thesis demonstrate that UPR components protect cells from hyperosmotic stress. Hac1p is a direct positive regulator of GSR genes. Rpd3p and Hac1p belong to the same pathway in activating GSR genes. Data also suggest that Hac1p does not contribute to the increase in nucleosomal histone acetylation levels after osmotic stress. The Gcn5 histone acetyltransferase contributes to the increase in histone acetylation observed after osmotic stress. The Rpd3p represses GSR genes in unstressed cells but also contributes to the activation of GSR genes after hyperosmotic shock. The Rpd3 large complex and not the small complex is involved regulating GSR gene expression. Subsequent investigation demonstrates that a possible mechanism by which the UPR contributes to the GSR gene activation is by the RNA polymerase II clearance at the GSR gene promoters.

## CONTENTS

---

<b>Abstract</b>	<b>i</b>
<b>Contents</b>	<b>iii</b>
<b>List of Tables</b>	<b>x</b>
<b>List of Figures</b>	<b>xi</b>
<b>Declaration and Statement of Copyright</b>	<b>xiv</b>
<b>Acknowledgement</b>	<b>xv</b>
<b>References</b>	<b>176</b>

## Chapter 1: INTRODUCTION

---

<b>1.1</b>	<b>Chromatin structure and gene expression</b>	<b>2</b>
1.1.1	Molecules affecting chromatin structure	4
1.1.1.1	Chromatin remodelling complexes	4
1.1.1.2	Histone Variants	6
1.1.1.3	Histone posttranslational modifications	7
1.1.2	Lysine acetylation- a post translational modification on histones	10
1.1.2.1	Histone deacetylases in yeast and the Rpd3p-Sin3p HDAC in <i>S cerevisiae</i>	11
1.1.2.2	Two Rpd3 complexes- the Rpd3 large (Rpd3L) and the Rpd3 small (Rpd3S) complex	13
1.1.2.3	Histone acetyltransferases in yeast and the Gcn5 HAT in <i>S. cerevisiae</i>	14
1.1.3	Nucleosomal lysine acetylation- site for protein-protein interaction domains	21
1.1.4	Lysine acetylation, chromatin dynamics and stress responses	23
1.1.5	Rpd3 HDAC and its role in transcriptional activation of genes	27
<b>1.2</b>	<b>Nutrient requirement and growth pattern in <i>S. cerevisiae</i></b>	<b>30</b>
1.2.1	A link between nutrient nitrogen availability and ER functionality in yeasts	31
1.2.2	The Unfolded Protein Response (UPR)	32
1.2.2.1	Mechanisms of signal transduction by the UPR in mammalian cells	33
1.2.2.2	The mechanism of UPR induction in <i>S. cerevisiae</i>	36
1.2.2.3	Protective role of UPR beyond ER stress	37
1.2.3	Nitrogen availability and <i>S. cerevisiae</i> differentiation control via the UPR	38
1.2.4	A mechanism of transcriptional repression of <i>EMGs</i> by Rpd3 HDAC and bZIP Hac1p	40
1.2.5	Rpd3 HDAC in ER stress and osmotic stress	41
<b>1.3</b>	<b>Stress response and transcriptional regulation in <i>S. cerevisiae</i></b>	<b>42</b>
1.3.1	Osmosis and organisms adapting to water stress in a natural environment	43
1.3.2	Osmotic stress, osmolytes and need for glycerol production in <i>S. cerevisiae</i>	44
1.3.3	The MAP kinase pathway in <i>S. cerevisiae</i>	45

1.3.3.1	Mechanism of Hog1 activation	49
1.3.3.2	Transcriptional regulators of HOG pathway	51
1.3.4	Cell wall integrity (CWI) pathway	54
1.3.4.1	Mechanism of CWI activation	54
1.3.4.2	Crosstalk between the CWI pathway and the osmotic pathway	55
1.3.5	Osmotic stress and nutritional adjustment in <i>S. cerevisiae</i>	57
1.3.6	Links and signal integration events between different pathways	58
1.3.6.1	ER stress and cell wall stress	58
1.3.6.2	ER stress and heat shock stress	59
1.3.6.3	ER stress and osmotic stress	60
1.3.6.4	ER and osmotic stress related bZIP transcription factors in plants	61
1.3.6.5	Links between bZIP transcription factors and osmotic stress in plants and mammals	62
<b>1.4</b>	<b>Aims and objectives</b>	<b>63</b>

## Chapter 2: MATERIAL AND METHODS

---

<b>2.1</b>	<b>Chemicals, reagents and commercial kits used in this study</b>	<b>67</b>
<b>2.2</b>	<b>Media reagents</b>	<b>69</b>
<b>2.3</b>	<b>Commercial antibiotics, enzymes and antibodies</b>	<b>70</b>
<b>2.4</b>	<b>Plasmids used in this study</b>	<b>71</b>
<b>2.5</b>	<b>Yeast strains used in this study</b>	<b>72</b>
<b>2.6</b>	<b>Oligodeoxynucleotides used in the study</b>	<b>74</b>
<b>2.7</b>	<b>Preparation of stock solutions and buffers</b>	<b>76</b>
2.7.1	Preparation of stock solutions	76
2.7.2	Buffers	77
2.7.3	Specialised solutions	77
2.7.4	Solutions for RNA work	79
2.7.4.1	Preparation of RNA reagents	79
2.7.4.2	Solutions that can be treated with DEPC	80
2.7.4.3	Solutions that can be treated with DEPC but cannot be autoclaved	81
2.7.4.4	Solutions that cannot be treated with DEPC but can be autoclaved	81

2.7.4.5	Composite solutions	81
<b>2.8</b>	<b>Microbiological media</b>	<b>82</b>
2.8.1	Liquid media preparation for <i>Saccharomyces cerevisiae</i>	82
2.8.2	Solid media preparation	83
<b>2.9</b>	<b>Yeast transformation</b>	<b>83</b>
2.9.1	Reagents	83
2.9.2	Protocol	83
<b>2.10</b>	<b>Spotting assay</b>	<b>85</b>
<b>2.11</b>	<b>Chromatin immunoprecipitation</b>	<b>85</b>
2.11.1	Quantitative PCR (qPCR) analysis of ChIPed DNA	87
<b>2.12</b>	<b>RNA isolation from yeast</b>	<b>88</b>
2.12.1	Reagents	88
2.12.2	Protocol	88
<b>2.13</b>	<b>RNA agarose gel electrophoresis</b>	<b>88</b>
2.13.1	Reagents	88
2.13.2	Protocol	89
2.13.2.1	Gel preparation	89
2.13.2.2	Sample preparation	89
2.13.2.3	Electrophoresis	89
2.13.2.4	Ethidium bromide staining of the size standard	90
<b>2.14</b>	<b>Capillary transfer of RNA</b>	<b>90</b>
2.14.1	Protocol	90
<b>2.15</b>	<b>Hybridization of Northern blot</b>	<b>91</b>
2.15.1	Reagents	91
2.15.2	Protocol	91
<b>2.16</b>	<b>Random Primed <sup>32</sup>P Labeling of DNA probes (Rediprime™II GE Healthcare)</b>	<b>93</b>
2.16.1	Reagents	93
2.16.2	Protocol	93
<b>2.17</b>	<b>Stripping of Northern blots</b>	<b>94</b>
2.17.1	Reagents	94
2.17.2	Protocol	94

### Chapter 3: THE UPR IS REQUIRED FOR SURVIVAL OF CELLS AGAINST HYPEROSMOTIC STRESS

---

<b>3.1</b>	<b><i>IRE1</i> and <i>HAC1</i> provide resistance against acute osmotic shock</b>	<b>96</b>
<b>3.2</b>	<b><i>HAC1</i> and <i>RPD3</i> provide hyperosmotic shock resistance</b>	<b>100</b>
<b>3.3</b>	<b>Hyperosmotic stress induces <i>HAC1</i> splicing</b>	<b>101</b>
<b>3.4</b>	<b>Discussion</b>	<b>104</b>
3.4.1	The ER and osmotic stress are linked	104
3.4.2	Protective role of UPR in hyperosmotic stress	106
3.4.3	<i>HAC1</i> induces ER chaperones during hyperosmotic stress	107
3.4.4	<i>HAC1</i> splicing attenuates at high osmolyte concentrations	107
3.4.5	Hac1p as a potential GSR gene activating transcription factor	109

### Chapter 4: *HAC1* AND *RPD3* TOGETHER ACTIVATE GSR GENES UNDER HYPEROSMOTIC STRESS

---

<b>4.1</b>	<b>Hac1<sup>i</sup> p is a positive regulator of GSR genes</b>	<b>112</b>
<b>4.2</b>	<b>Hac1<sup>i</sup> acts through Rpd3L to potentiate transcription of GSR genes.</b>	<b>115</b>
<b>4.3</b>	<b>Hac1p does not affect nucleosomal histone acetylation pattern for GSR gene activation</b>	<b>120</b>
<b>4.4</b>	<b>Discussion</b>	
4.4.1	The UPR and GSR gene regulation are connected	123
4.4.2	0.6 M NaCl and 1.2 M sorbitol for 20 min is optimal for inducing GSR genes	123
4.4.3	<i>HAC1</i> regulates a subset of GSR genes under hyperosmotic shock	124
4.4.4	Does MAP kinase Hog1 affect the positive role of <i>HAC1</i> in GSR gene regulation?	125
4.4.5	Hac1p acts through Rpd3L to regulate GSR gene expression	126
4.4.6	<i>HAC1</i> does not contribute to nucleosome histone acetylation of GSR gene promoters	127
4.4.7	Investigating role of <i>RPD3</i> in GSR gene activation	128



---

## Chapter 5: THE ROLE OF *RPD3-SIN3* HDAC IN GSR GENE REGULATION

---

<b>5.1</b>	<b>Rpd3 complexes are associated with GSR promoters independent of osmotic stress</b>	<b>131</b>
<b>5.2</b>	<b>The GSR gene activation is partially independent of Rpd3p catalytic activity</b>	<b>139</b>
<b>5.3</b>	<b>Discussion</b>	<b>144</b>
5.3.1	Role of Rpd3 HDAC in epigenetic regulation of GSR genes	144
5.3.2	The Rpd3L complex is required for GSR gene activation	146
5.3.3	Proposing a mechanism of how the UPR components regulate GSR gene expression during hyperosmotic stress	149
5.3.4	The UPR components integrate into osmotic stress	150

---

## Chapter 6: A MECHANISM OF SIGNAL INTEGRATION BETWEEN THE UPR PATHWAY AND OSMOTIC STRESS

---

<b>6.1</b>	<b>Hac1<sup>p</sup> and Rpd3p stimulate the release of Pol II from the promoters of GSR genes</b>	<b>154</b>
<b>6.2</b>	<b>Gcn5 HAT contributes towards increased nucleosome histone acetylation after osmotic stress</b>	<b>158</b>
<b>6.3</b>	<b>Discussion</b>	<b>161</b>
6.3.1.	Signal integration between the UPR and the GSR pathways	161
6.3.2.	RNA pol II S5 and S2 CTD phosphorylation levels correlates with RNA pol II at 5' and 3' regions of GSR genes respectively	161
6.3.3.	Gcn5 HAT contributes to increased nucleosomal histone acetylation of GSR genes during hyperosmotic stress	163
6.3.4.	Potential integration of the UPR with other stress pathways	165

## Chapter 7: DISCUSSION

---

<b>7.1</b>	<b>Integration of UPR pathway into osmotic stress</b>	<b>167</b>
<b>7.2</b>	<b><i>HAC1</i> acts via <i>RPD3</i> to activate a large subset of GSR genes</b>	<b>168</b>
<b>7.3</b>	<b>Role of Rpd3p in GSR gene regulation</b>	<b>173</b>
<b>7.4</b>	<b>Crosstalk between the ER stress pathway and osmotic stress</b>	<b>171</b>
<b>7.5</b>	<b>Epigenetic regulation, UPR and human diseased states</b>	<b>173</b>

## LIST OF TABLES

<b>Table No.</b>	<b>Title</b>	<b>Page No.</b>
<b>1.1</b>	An overview of the known yeast HDACs.	<b>12</b>
<b>1.2</b>	The presence of the known subunits of the Rpd3L complex other than the Rpd3p, Sin3p and Ume6p.	<b>14</b>
<b>1.3</b>	The SAGA/SLIK complex biological function component (this table has been taken from the article by Baker and Grant, 2007).	<b>17</b>
<b>1.4</b>	List of known TFs associated with Hog1 (From Hohmann, 2002)	<b>52</b>
<b>2.1</b>	List of chemicals, reagents and commercial kits used in this study	<b>67</b>
<b>2.2</b>	List of media reagents used in this study	<b>69</b>
<b>2.3</b>	List of Antibiotics, enzymes and antibodies used in this study	<b>70</b>
<b>2.4</b>	The plasmids used in this study	<b>71</b>
<b>2.5</b>	Yeast strains used in this study	<b>72</b>
<b>2.6</b>	Oligonucleotides used in this study	<b>74</b>

## LIST OF FIGURES

Figure No.	Title	Page No.
1.1	A few basic concepts revisited in chromatin regulation and gene expression processes	4
1.2	Main chromatin remodelling complexes known in yeast (From Narlikar et al., 2002)	5
1.3	Histone tails are critical for the posttranslational modification of histones	7
1.4	Some posttranslational histone tail modifications in yeast and higher eukaryotes	8
1.5	HATs and HDACs regulate nucleosomal histone acetylation	10
1.6	The yeast SAGA and NuA4 complexes	16
1.7	Functional attributes of the SAGA and the NuA4 complexes	17
1.8	Role of the two Rpd3 complexes in transcriptional regulation in <i>S. cerevisiae</i>	28
1.9	A diagram showing growth pattern of yeast growth in presence or absence of carbon and nitrogen sources	31
1.10	Three mammalian ER resident sensors for misfolded proteins	36
1.11	ER stress and nitrogen availability is linked in yeast	39
1.12	A mechanism of regulating EMGs via Rpd3 and Hac1 in <i>S. cerevisiae</i>	41
1.13	A diagram showing the molecules involved in the MAPK cascade signalling.	46
1.14	A sketch of the yeast MAPK pathways (modified from Hohmann, 2002).	48
1.15	The Sln1 branch of the Hog1 pathway	51
1.16	A sketch of the CWI pathway	56
1.17	A link between ER stress and CW stress	59
1.18	Summary of the aim and objectives	64

<b>Figure No.</b>	<b>Title</b>	<b>Page No.</b>
<b>2.1</b>	Graphical depiction of the <i>ALD3</i> , <i>CTT1</i> , <i>HSP12</i> , and <i>STL1</i> loci indicating the location diagnostic PCR products in the promoters and 3' end of the ORFs that were used to analyze ChIPs.	<b>87</b>
<b>2.2</b>	Diagram representing capillary transfer of RNA	<b>90</b>
<b>3.1</b>	The UPR is required for survival of hyperosmotic stress.	<b>98</b>
<b>3.2</b>	Overexpression of Hac1 <sup>i</sup> slightly enhances resistance to osmotic stress	<b>99</b>
<b>3.3</b>	<i>HAC1</i> and <i>RPD3</i> provide resistance against osmotic shock.	<b>100</b>
<b>3.4</b>	Osmotic stress induces <i>HAC1</i> splicing	<b>102</b>
<b>3.5</b>	Higher concentrations of osmotic agents arrest <i>HAC1</i> splicing	<b>104</b>
<b>3.6</b>	ER stress does not augment Hog1p activation in osmotically-stressed cells	<b>110</b>
<b>4.1</b>	Optimizing conditions for inducing GSR genes under osmotic stress.	<b>113</b>
<b>4.2</b>	Hac1 <sup>i</sup> potentiates transcription of GSR genes during osmotic stress.	<b>114</b>
<b>4.3</b>	Hac1 <sup>i</sup> acts through Rpd3L to potentiate transcription of GSR genes.	<b>116</b>
<b>4.4</b>	Hac1p directly binds to GSR gene promoters.	<b>118</b>
<b>4.5</b>	Hac1p interacts with Rpd3pL complex to regulate GSR genes.	<b>119</b>
<b>4.6</b>	Osmotic stress induces promoter nucleosome acetylation and nucleosome loss in GSR promoters	<b>122</b>
<b>5.1</b>	Deletion of <i>RPD3</i> increases nucleosomal histone acetylation before and after hyperosmotic stress	<b>133</b>
<b>5.2</b>	Rpd3 complexes at GSR promoters are present before and after osmotic stress	<b>134</b>
<b>5.3</b>	The Rpd3L complex interacts with Hac1p and is present at GSR promoter regions before and after osmotic stress	<b>136</b>
<b>5.4</b>	The Rpd3S complex is dispensable for induction of GSRs by osmotic stress	<b>138</b>
<b>5.5</b>	The Rpd3L complex is required for induction of GSR genes by osmotic stress	<b>139</b>
<b>5.6</b>	The GSR gene activation is partially independent of Rpd3-Sin3 catalytic activity	<b>141</b>
<b>5.7</b>	Rpd3 point mutant acetylation levels are similar to the WT strain after osmotic stress	<b>143</b>

<b>Figure No.</b>	<b>Title</b>	<b>Page No.</b>
<b>6.1</b>	Hac1 <sup>p</sup> and Rpd3p stimulate the release of RNA pol II from the promoters of GSR genes	<b>155</b>
<b>6.2</b>	The ratio of RNA pol II at 3' to 5' end from Figure 6.1 correlates with mRNA levels for the same strains in Figure 4.2	<b>156</b>
<b>6.3</b>	The increase in Pol II CTD S5 and S2 levels correlates with Pol II levels at the 5' and 3' ends of GSR genes respectively	<b>157</b>
<b>6.4</b>	Gcn5 HAT contributes towards increased nucleosome acetylation after osmotic stress	<b>159</b>
<b>6.5</b>	Gcn5 HAT is present at GSR promoters after osmotic stress	<b>160</b>
<b>7.1</b>	A diagram suggesting a mechanism of GSR gene activation in (A) WT and (B) <i>RPD3</i> deletion cells	<b>173</b>

## LIST OF ABBREVIATIONS

A600nm	Absorbance measured at 600nm wavelength
CHCl <sub>3</sub>	Chloroform (Trichloromethane)
dNTP	Deoxynucleoside triphosphate
EDTA	Ethylenediamine tetraacetic acid
EtOH	Ethanol
Kb	Kilobases
kDa	kilo Dalton (unit in mass)
KOAc	Potassium acetate
LiOAc	Lithium acetate
LiCl	Lithium chloride
M	Molar
mM	millimolar
mg	milligrams
MgCl <sub>2</sub>	Magnesium chloride
min	minutes
ml	millilitre
NaCl	Sodium chloride
Na <sub>2</sub> CO <sub>3</sub>	Sodium carbonate
NaH <sub>2</sub> PO <sub>4</sub>	Sodium dihydrogen phosphate
Na <sub>2</sub> HPO <sub>4</sub>	Disodium hydrogen phosphate
ng	nanogram
nm	nanometer
∅	diameter
°C	degree celsius
PCR	Polymerase chain reaction
PEG4000	Polyethylene glycol 4000
RNase A	Ribonuclease A
rpm	revolutions per minute
RT	Room temperature
s	Seconds
SD	Synthetic dextrose medium
SDS	Sodium dodecyl sulfate
TE	Tris ethylene diaminetetraacetic acid
Tris	tris(hydroxymethyl)aminomethane
Tris·HOAc	tris acetic acid
Tris-HCl	tris hydrochloric acid
YNB	Yeast nitrogen base
YPAc	Yeast extract peptone Acetate medium
YPD	Yeast extract peptone dextrose medium
µgm	microgram
µM	micromolar
µm	micrometer or micron or 1x10 <sup>-6</sup> of a meter
Δ	Deletion
λ	wavelength
µl	microlitre

## **DECLARATION**

---

I confirm that this thesis and the original work described therein are my own work. Appropriate credit has been given to work of others when the reference has been made. No material contained in this thesis has been previously submitted for the award of a higher degree.

## **STATEMENT OF COPYRIGHT**

---

This thesis and the work therein have been supplied on the understanding that it is copyright material. No quotation from this thesis may be published without prior consent and without proper acknowledgement of the author.



## ACKNOWLEDGEMENT

---

Last four years have been an exciting part of my life and there are so many people to whom I would like to express my thanks. Firstly I would like to thank my supervisor, Dr Martin Schröder for your excellent guidance, encouragement and support, and for giving me the opportunity to work in an amazing lab and research field. Thank you for always having time to teach me, train me and look at my results.

Huge thanks to past and present members of Lab 2, many of whom are such close friends now - Dr Claire Bertrand (mum, froggy!), Dr Vipul Parmar (titi, pu!), Dr Natalie Strudwick (aunty, roast beef!), Dr Sergej Sestak (Sergeko!), Dr Ewa Mularczyk (Ewunia!), Dr Saeed Khan, Monica (Monu!), Louise (lou!), Dr David Cox (please gift me that 'flying planes' game!), Max (maxi, my most favourite 'geordie' and his lovely family!), Dr Vanja Pekovic (Vanyori!), Adina (Adi!), Dr Samantha Dainty (Samy!), Jamie, Lesley, past and present members of Lab1 and Lab3! Thank you all so very much for being a brilliant set of scientific professionals in the lab/department and for always having some time to spend with me either during work or coffee break or while having our crazy fun times outside the lab! I would like to thank Prof Keith Lindsey, Dr Heather Knight and Dr Ron Croy for your kind words of encouragement. Many thanks to Prof Marc Knight, Dr Adam Benham, Dr Jen Topping and lots other lovely people in our Department who have been so good to discuss experimental issues or to have a bit of a chinwag! I extend my gratitude to Prof Mike Pennington and Dr Paula Martin from the Science Outreach Program, Durham University. The teaching fellowship was a great experience! The school, Excelsior Academy, Newcastle where I taught, the determined set of teachers: Debbie, Kate and Richard and many others I've had the opportunity to work with, and pleasure of teaching so many students has been absolutely fantastic! I am indebted to so many excellent teachers during my undergraduate and postgraduate days and particularly those who inspired me to work in the field of Molecular Biology/Molecular Genetics, thank you all ever so much.

I also extend a huge thanks to YUM, Durham University; your sandwiches have been a saviour in more ways than one! To my friends at Oriental Museum, thank you! To so many friends I've made from different nationalities in Ustinov College, I thank you all. My thanks to Dr Penny Wilson and Theresa Mckinven, for the Ustinov Accommodation Scholarship!

I would like to extend a special word of thanks to the 'Parmario' family and 'Pyati' family and a couple of other friends who have been the best ever! To other friends, old and new with whom I have had real good times, thanks a lot! To the badminton crazy gang from the 2010 Ustinov batch, you all have been the best! I would like to thank my close friends and relatives in India for standing by me. Finally, to mum, dad and sister: my strength and the three everlasting joys of my life. Thank you for always supporting me and being unconditional. You three have all my love and gratitude. This thesis is dedicated to you 'amma', 'appa' and 'guddu'.

## Chapter 1

---

### INTRODUCTION

All organisms have developed mechanisms to deal with stress. Yeast cells have evolved mechanisms to adapt to stresses including osmotic stress, cell wall stress, ER stress, oxidative stress and heat stress. Gene regulation is central in responding to stress environments and yeast cells regulate either a subset of genes or many genes across the entire genome in a coordinated attempt to regain cellular homeostasis.

In the introduction chapter, a general overview of gene regulation will be presented in yeasts and higher organisms. The contents of this section will present basic information on chromatin structure and molecules regulating the chromatin structure. The introduction will then concentrate on histone acetylation as a posttranslational modification of histones and the molecules involved in this modification. Recent literature has linked molecules involved in histone acetylation to stress responses like osmotic stress and ER stress. The introduction will then present an overview of ER, osmotic and cell wall stress responses in yeast, *S.cerevisiae* specifically. The osmotic stress and ER stress will then be linked to gene regulation from which the aims and objectives of this study will be derived.

### **1.1 Chromatin structure and gene expression**

DNA associates closely with histone proteins to form the chromatin which is enclosed within the cell nucleus. The benefits of packaging DNA with proteins include condensing it to fit into the nucleus, aiding the control and coordination of gene expression and replication and also the prevention of DNA damage. Largely, the structure of the chromatin depends on the stage of the cell cycle.

The packaging of DNA with histones to form chromatin is explained by the 'beaded' nucleosomes which consist of a pair of four core histones-H2A, H2B, H3 and H4. A set of these four core

histones form a tetramer. Two tetramers together form an octamer around which a 146bp region of DNA is wound to form a 'bead'. This results in the DNA being compacted five to ten fold (Kornberg, 1974). The amino acid terminal end of histones form the histone tails regions. If the chromatin structure is closed (the heterochromatin) then genes are not transcribed. This is because the packed chromatin structure sterically interferes with access of proteins like transcription factors and the general transcription machinery to regulatory sites present on the DNA. When the chromatin structure is open (the euchromatin), DNA is accessible for DNA template associated molecular processes. Chromatin structure and gene expression processes are hence linked. But the event of gene activation cannot be categorised as a step-wise, ordered phenomenon. Where in one case the nucleosomes may be repositioned at a promoter site by chromatin remodelling complexes, in other cases it may be exactly vice-versa where TFs, RNA polymerase and other proteins are recruited to promoters prior to the chromatin remodellers (Felsenfeld and Groudine, 2003). Figure 1.1 revisits some basic concepts in gene regulation and transcription which is also the essence of this thesis.

In this section of the introduction chapter the following topics will be described keeping the information focussed on *S. cerevisiae*, but an overview of the same in other eukaryotes will also be presented:

- Important molecules which affect chromatin structure during gene expression
- Post-translational modifications of histone proteins
- Lysine acetylation and deacetylation on the N-terminal tails of core histones
- Histone deacetylases (HDACs) and Histone acetyltransferases (HATs)
- Nucleosomal histone lysine acetylation, gene regulation and stress

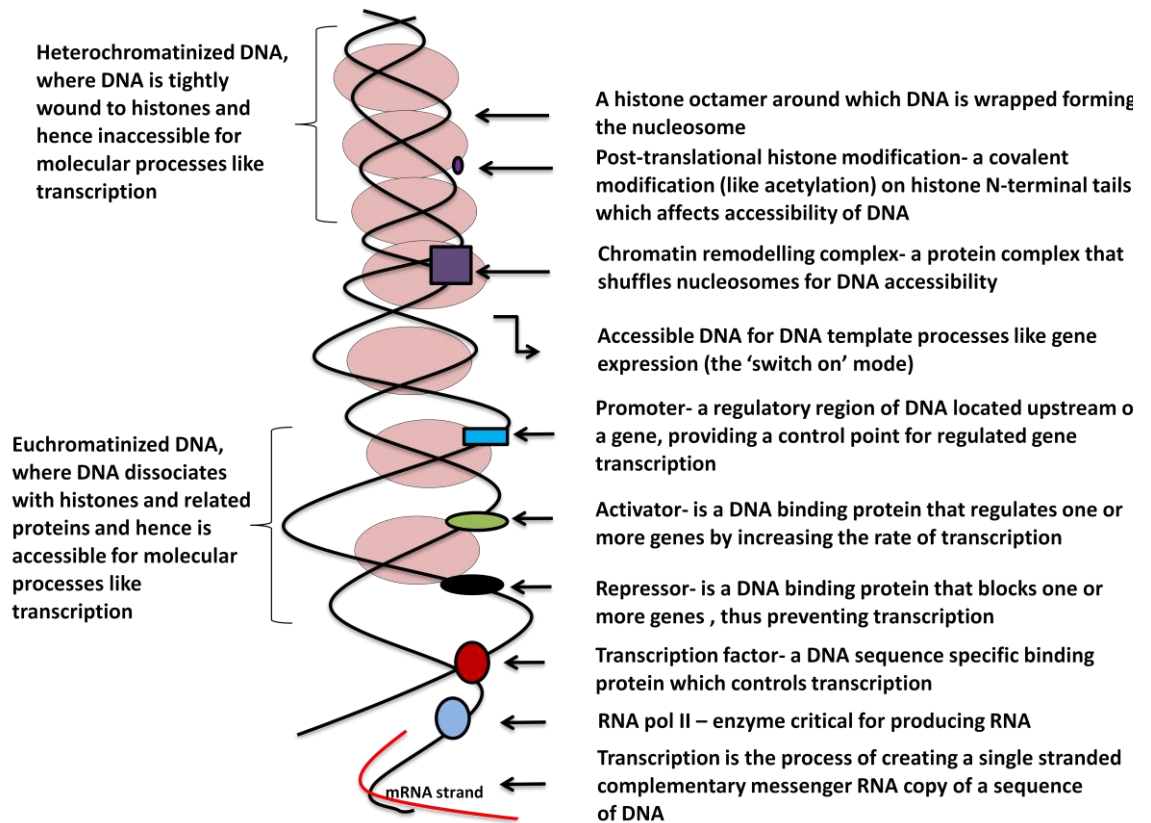

**Figure 1.1 A few basic concepts revisited in chromatin regulation and gene expression processes** The sketch represents some of the basic but essential concepts and the molecules involved which are central to this thesis.

### 1.1.1 Molecules affecting chromatin structure

#### 1.1.1.1 Chromatin remodelling complexes

There are many molecules which affect the chromatin structure which eventually lead to the dissociation of the histone protein from DNA for a molecular process like transcription to take place (Berger, 2002; Ptshane and Gann 2001). Firstly, there are the chromatin remodelling complexes which are ATP dependent which regulate chromatin structure (Becker and Hörz, 2002). ATP-dependent complexes can move nucleosome positions thereby exposing or occluding DNA

sequences. The ATPase subunits display homology only within the ATPase domain and contain additional domains. The two best studied family of remodelling complexes in yeast are the SWI/SNF (Switch/sucrose non fermentable) family and the ISWI (imitation switch) -based family of complexes (Figure 1.2).

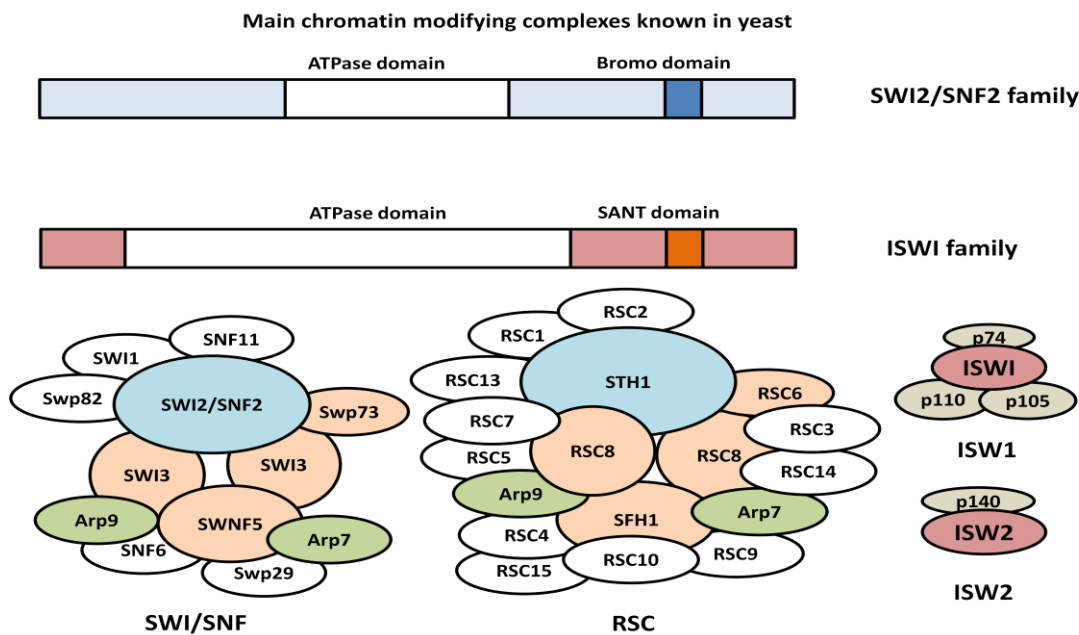

**Figure 1.2 Main chromatin remodelling complexes known in yeast (From Narlikar et al., 2002)**

The RSC (**R**emodells structure of **chromatin**) complex is another chromatin remodelling complex which was discovered in 1996 (Cairns et al., 1996) and has some subunits common with the SWI/SNF complex as shown in Figure 1.2. The most well known mechanism by which the remodelling complexes make DNA accessible is the ‘sliding’ of DNA with respect to the histone octamer (Meersseman et al., 1992). Sliding involves the identical amounts of entry and exit points of the DNA in the same direction. This results in the octamer being repositioned resulting in the DNA originally interacting with the octamers becomes non-nucleosomal. The roles of the remaining subunits in the remodelling complexes have been hypothesised to perform two

functions. Firstly, the subunits can modulate remodelling activity of the ATPase subunit or secondly, they can be involved in directing the remodelling complex to gene promoters directly or via transcriptional activators.

### **1.1.1.2 Histone Variants**

Histone variants may replace one of the core histones, thereby affecting the dynamics of the chromatin (Ahmed and Henikoff, 2002). In yeast two of the nucleosomal histone families, H2A and H3 have highly conserved variants with specialised functions. Histone H1 has numerous sequence variants such as H1<sup>0</sup>, H5, and the spermand testis-specific variants (Kamakaka and Biggins, 2005). Among the core histones, H2A has the largest number of variants, including H2A.Z, MacroH2A, H2A-Bbd, H2AvD, and H2A.X (Ausio and Abbot, 2002; Redon et al., 2002; Fernandez-Capetello et al., 2004). The H2A.X variant plays a role in DNA double stranded breaks (Redon et al., 2002). The H2A.Z variant has been associated with genes during transcriptional activation and is essential for development in higher eukaryotes. The H2A.Z variant is incorporated into nucleosomes as a H2A.Z/H2B dimer by the Swr1 complex and by the SRCAP and p400/Tip60 complexes in mammalian cells (Svotelis et al., 2009). Another variant for histone H3, the H3.3 in metazoans has also been associated with active transcription. Its role in histone replacement is conserved to the single histone H3 in yeast. With a strikingly small amino acid difference to the canonical histone H3, the H3.3 variant is associated with a variety of cellular and developmental processes (Elsaesser et al., 2010). In addition, there are the centromeric histone H3 variant (Albig et al., 1996) and the mammalian testes tissue-specific histone H3 variant, H3.4 (Witt et al., 1996). The literature does not provide much information on the variants in either H2B or H4 core histones.

### 1.1.1.3 Histone posttranslational modifications

Other than chromatin remodellers and histone variants, the post translational modification of the histone tails also significantly contributes to the chromatin dynamics. The covalent post-translational modifications of histones are one of the prominent means to regulate chromatin structure. Regulation of chromatin structure is important for the control of DNA-templated processes like gene expression and silencing.

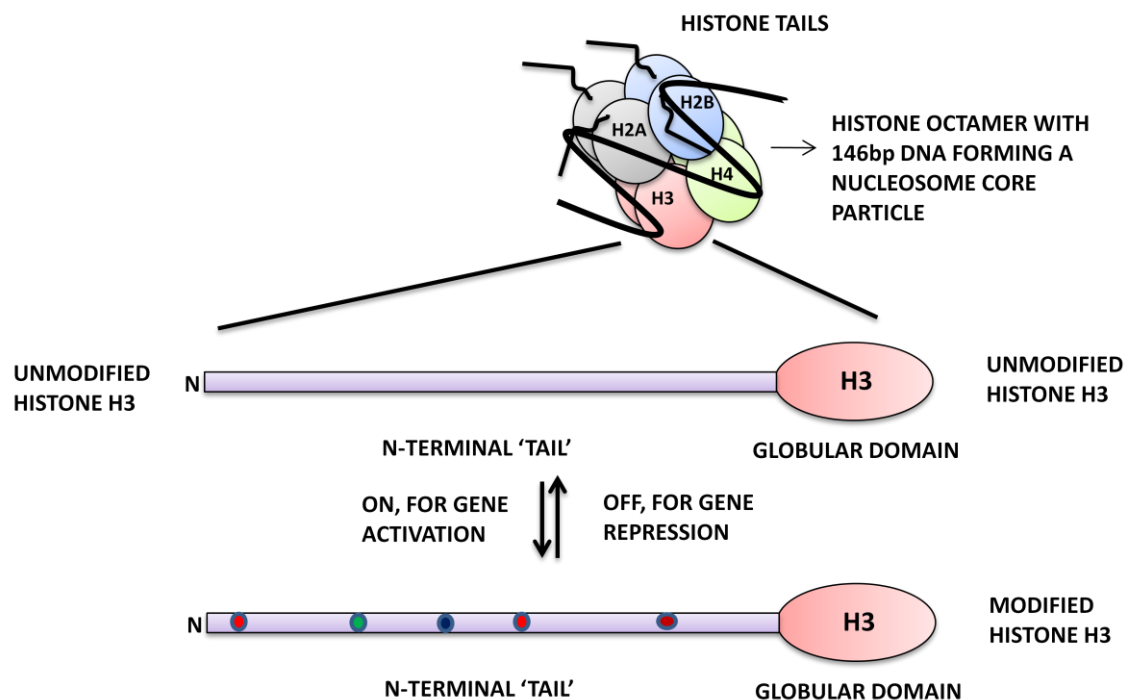

**Figure 1.3 Histone tails are critical for the post translational modification of histones** A sketch representing the post-translational modification of histone tails that are critical in affecting chromatin structure. The different coloured dots in N-terminal tail of a representative core H3 histone illustrate modifications like acetylation, methylation and phosphorylation which contribute to activation of genes ('on' mode).

The idea of how post translational modifications of histones affect transcription is shown in Figure 1.3. Core histones have N-terminal tails whose sequences are highly conserved from yeast to human. Genetic studies in yeast have demonstrated that these histone tails are essential for



cellular viability because simultaneous deletion of H3-H4 tails or H2A-H2B tails is lethal (Ling et al., 1996). Involvement of histone tails in control of gene expression may result from two interlinked but distinct mechanisms i) a change in structure or composition of the nucleosome and/or the nucleosome fibre and ii) the modulation of the interaction of the histone tails with regulatory factors (Hartzog and Winston, 1997). The N-terminal tails of the four core histones are targets for posttranslational modifications that correlate with changes in gene activity. Contribution of histone tails in maintaining nucleosome structure and nucleosome arrays has been demonstrated (Ausio et al., 1989; Fletcher et al., 1995; Tse et al., 1998).

Chromatin is not an inert structure but rather a structured and instructive DNA scaffold which responds to a stimulus to regulate many functions of the DNA molecule. An important component of the chromatin which plays a key role in regulating the DNA is the modification of histones. A large number of modifications are currently known as shown in Figure 1.4 and the complexity of their action is just beginning to be understood. Evidence has been accumulating over the past three decades, which confirms that histone modifications play a fundamental role in many biological processes which involve manipulation and expression of DNA.

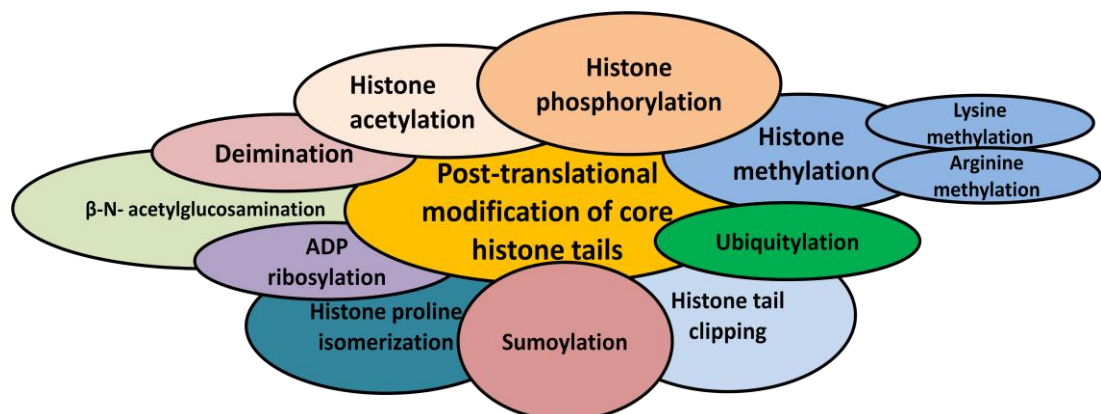

**Figure 1.4 Some posttranslational histone tail modifications in yeast and higher eukaryotes** A cartoon showing the range of histone tail posttranslational modifications possible in yeast and higher eukaryotes.

Histone tail modifications are not an independent event occurring during chromatin regulation which makes DNA accessible. Instead they are known to recruit remodelling enzymes which use ATP-hydrolysis to reposition nucleosomes and also act as substrates for essential chromatin related enzymes. The recruitment of regulatory proteins and complexes with specific enzymatic functions is now an accepted idea of how histone modifications mediate their function. The chemical nature of these modifications is a covalent interaction between the donor and the acceptor molecules. Some of the well studied histone posttranslational modifications are histone acetylation, histone phosphorylation and histone methylation. These three histone modifications involve the addition or removal of small functional groups to the specific amino acids in the histone tail regions. In contrast, ubiquitylation and sumoylation involve the addition of much larger functional groups.

Lysine acetylation, one of the most dynamic modifications is regulated by the opposing action of two families of enzymes, HATs and HDACs. Like histone acetylation, the phosphorylation of histones is highly dynamic. It takes place on serines, threonines and tyrosines, predominantly but not exclusively in the N-terminal histone tails. The level of phosphorylation is controlled by kinases and phosphatases which add or remove the phosphate group respectively (Oki et al., 2007). Histone methylation occurs mainly on lysine and arginine in histone tail regions. Unlike acetylation or phosphorylation, methylation does not alter the charge on the histone protein. In addition, the methylation modification is of a more complex nature as lysines can be mono-, di- or trimethylated whereas arginines can be mono-, symmetrically or asymmetrically di-methylated (Lan et al., 2009; Bedford and Clark 2009; Ng et al., 2009). Further sections beyond this point of the introduction chapter will focus on lysine acetylation because an important molecule which is a point of focus for my study is the Rpd3p-Sin3p HDAC in *S. cerevisiae*.

### 1.1.2 Lysine acetylation- a post translational modification on histones

The lysine acetylation was discovered as a covalent histone modification process in 1964 by the pioneering studies by Vincent Allfrey (Allfrey et al., 1964). It is a reversible process and is catalysed by enzymes acetyl transferase and deacetylase that act antagonistic to each other. Lysine (K) acetylation is a transfer of an acetyl moiety from acetyl-coenzyme A (CoA) cofactor to the  $\epsilon$ -amino group of a lysine residue. The deacetylation of histone tails is brought about by HDAC and acetylation by HAT (Figure 1,5), with one of the common substrates for both enzymes being the  $\epsilon$ -NH<sub>2</sub> groups of the lysine residues in N-terminal tails of the core nucleosomal histones (Bradbury, 1992).

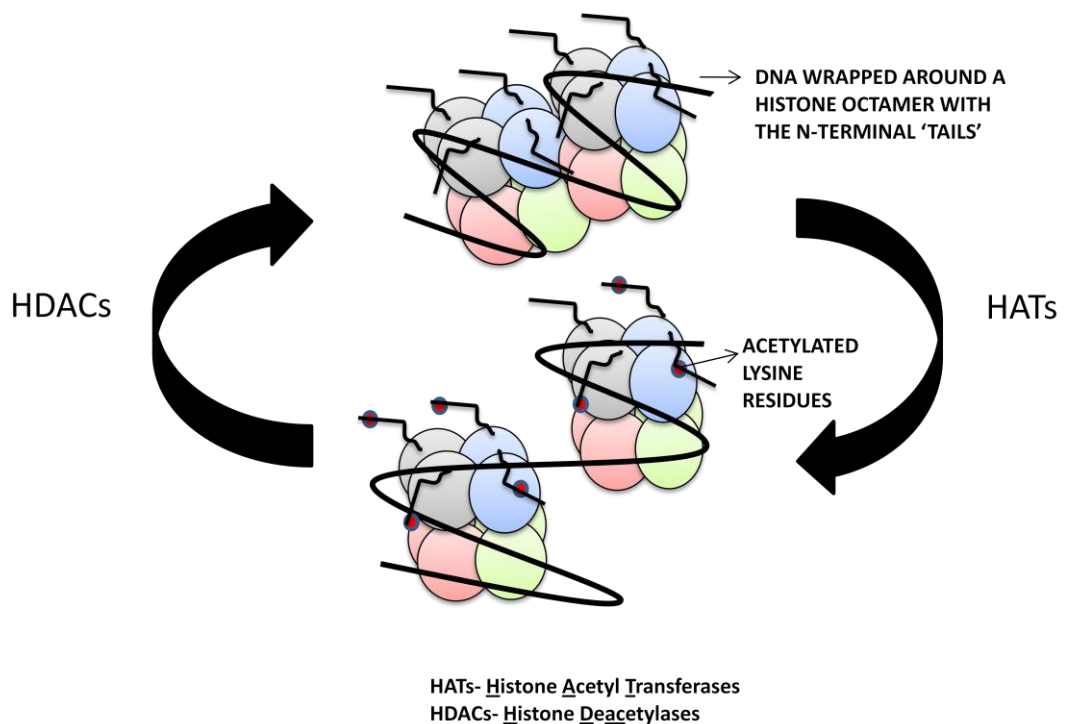

**Figure 1.5 HATs and HDACs regulate nucleosomal histone acetylation** A cartoon showing histone acetyltransferases and histone deacetylases which regulate chromatin structure by post-translationally modifying lysine acetylation, the common substrates for both enzymes are the N-terminal tail lysine residues of the core histones.

Before the 1990's, a much simpler understanding existed of how genes were regulated. One of the ideas was that transcriptional regulation was correlative with the acetylation pattern on nucleosomal histones. An overall increase in histone acetylation resulted in a transcriptionally active state whereas during transcriptional repression there was a decrease in histone acetylation. After 1990's this view of the chromatin state during transcriptional regulation became more complicated. The biochemical characterisation of the histone acetyltransferases and deacetylases revealed a more complex pattern of histone acetylation and deacetylation of the chromatin (Travis et al., 1984; Kleff et al., 1995; Glozak et al., 2005). In the past two decades, an impressive amount of literature has been collected on lysine acetylation as a posttranslational modification. The targets for lysine acetylation have now extended from histones to transcription factors and other proteins such as metabolic enzymes and signalling molecules in the cytoplasm. Lysine acetylation affects a number of protein properties including regulation of DNA-protein interaction, non-histone proteins, transcriptional activity, nuclear stability and involvement in various signalling pathways (Spange et al., 2009; Chowdhary et al., 2009; Kim et al., 2006; Glozak et al., 2005; Patel et al., 2011). In recent years the dynamic state of lysine histone acetylation has been linked to various pathological states and diseased conditions (McCullough and Grant, 2010; Lu et al., 2009; Yang and Seto, 2008; Haberland et al., 2009; Minucci et al., 2001; Saha and Pahan, 2006).

#### **1.1.2.1 Histone deacetylases in yeast and the Rpd3p-Sin3p HDAC in *S cerevisiae***

There are 10 known HDACs in yeast *S.cerevisiae* which have been categorised into three main classes. These classes were made based on the phylogenetic analysis and sequence homology to yeast Rpd3 (**R**educed **p**otassium **d**eficiency 1), Hda1 and Sir2 (**S**ilent **i**nformation **r**egulator 2) HDACs (Gregorette et al., 2004; Grozinger and Schreiber, 2002; Khochbin et al., 2001; Pandey et

al., 2002). The first deacetylases for lysine residues in mammalian cells was HDAC1 and correspondingly in yeast was Hda1 (Rundlett et al., 1996; Taunton et al., 1996). *HDA1* (Histone deacetylase 1) encodes for a histone deacetylase enzyme (Rundlett et al., 1996). It is a 350kDa protein complex and was found to be sensitive to the deacetylase inhibitor trichostatin A. *HDA2* and *HDA3* are genes which encode for the other interacting partners of Hda1p (Wu et al., 2001). Subsequently, other deacetylases were discovered. Table 1.1 lists out the names and classes of the known Rpd3 HDACs in yeast along with their mechanism of catalysis and localisation in the cell.

Class	Name	Mechanism of catalysis	Cell localisation
I	Rpd3, Hos1, Hos2	Zn <sup>2+</sup> ion dependent	Ubiquitous
II	Hda1, Hos3	Zn <sup>2+</sup> ion dependent	Moves between the nucleus and cytoplasm
III	Sir2, Hst1, Hst2, Hst3, Hst4	NAD <sup>+</sup> dependent	Shuttles between the nucleus, cytoplasm and mitochondria

**Table 1.1 gives an overview of the known yeast HDACs**

*RPD1* (Reduced potassium deficiency 1, also known as *SIN3*, *UME4* and *GAM3*) is required for maximal activation and repression of diverse yeast genes. The product of the *SIN3* gene codes for a 175-kDa protein which functions as a transcriptional corepressor in *S cerevisiae* (Kasten et al., 1997). Sin3 (Switch independent 3), a co-repressor known to interact with DNA-binding protein, was found in the same complex as Rpd3 (Alland et al., 1997; Hassig et al., 1997; Heinzl et al., 1997; Kadosh and Struhl, 1997; Kasten et al., 1997; Laherty et al., 1997; Nagy et al., 1997). *RPD3* (Reduced potassium deficiency 3, also known as *REC3*, *SDI2* and *SDS6*) was shown to encode

a second protein required for maximum transcriptional activation and repression (Vidal and Gaber, 1991; Dora et al., 1999; Stillman et al., 1994; Sussel et al., 1993). Another protein, Ume1p (Unscheduled meiotic gene expression 1) was shown to be critical for the repression of meiotic genes and to interact with the Rpd3p-Sin3p HDAC and contributed to its enzymatic activity (Strich et al., 1989; Kurdistani et al., 2002; Mallory and Strich, 2003).

#### **1.1.2.2 Two Rpd3 complexes- the Rpd3 large (Rpd3L) and the Rpd3 small (Rpd3S) complex**

Two distinct complexes of Rpd3 have been identified, the Rpd3 small complex of 0.6 MDa (Rpd3S) and a large complex of 2.1 MDa (Rpd3L) (Kasten *et al.*, 1997; Keogh *et al.*, 2005; Carrozza *et al.*, 2005). These two complexes have three common subunits, namely, Rpd3, Sin3, and Ume1. The Rpd3 large complex includes subunits like Sap30, Pho23, Rxt1, Rxt2, Dep1, and Sds3 which are specific to the large complex. Table 1.2 lists the known subunits of the Rpd3 large complex, their function and the citation which originally described them. Rco1 (Regulation of conidiation 1) and Eaf3 (Esa1p associated factor 3) were found to be specific for the small Rpd3 complex (Keogh et al., 2005; Carrozza et al., 2005; Huh et al., 2003). The functional differences between the two complexes were shown using clustering of genetic interactions and gene expression profiles (Tong et al., 2001 and 2004; Keogh et al 2005). Eaf3 was also identified as a component of the HAT complex, NuA4 (Eisen et al., 2001; Krogan et al., 2004).

	<b>Subunit of Rpd3L complex</b>	<b>Role</b>	<b>Reference</b>
1.	Sds3 (Suppressor of defective silencing 3)	maintains the integrity and the catalytic activity of the Rpd3p-Sin3p complex	Lechner et al., 2000
2.	Dep1 (Disability in regulation of expression of genes involved in phospholipid biosynthesis)	integral part of the Rpd3L complex involved in suppressing genes and keeping the complex intact	Lamping et al., 1994
3.	Sap30 (SIT4 protein phosphatase associated protein)	required for the normal function of the Rpd3L complex in maintaining gene repression	Zhang et al., 1998
4.	Pho23 (Phosphate metabolism)	involved in the normal function of gene regulation and silencing	Loewith et al., 2001
5.	Cti6, same as Rxt1 (Cyc8-Tup1 Interacting protein 6)	a part of the Rpd3L complex containing a PHD finger domain which is essential for growth under low iron and regulation of telomeric silencing but is not involved in transcriptional repression	Puig et al., 2004
6.	Ash1 (Asymmetric synthesis of HO 1)	sequence specific repressor stably associated with the Rpd3L complex	Carrozza et al., 2005
7.	Ume6 (Unscheduled meiotic gene expression 6)	sequence specific repressor stably associated with the Rpd3L complex	Carrozza et al., 2005
9.	Raf60, same as Rxt2 (Rpd3-associated factor)	Required for normal Rpd3L complex activity and repression of gene expression	Colina and Young, 2005
10.	Rxt3	Subunit of Rpd3L complex involved in deacetylation	Samanta and Liang, 2003

**Table 1.2 Lists out the presence of the known subunits of the Rpd3L complex other than Rpd3p, Sin3p and Ume6p.**

### **1.1.2.3 Histone acetyltransferases in yeast and the Gcn5 HAT in *S. cerevisiae***

In mammals, the first nuclear Gcn5 HAT was identified in 1996 (Brownell et al., 1996). In yeast, Gcn5 (General control nonderepressible 5) is required for the expression of a subset of genes (Lucchini et al., 1984; Georgakopoulos and Thireos, 1992; Kleff et al., 1995). Yeast Gcn5 is found in at least 2 distinct multiprotein complexes and neither of these is associated with RNA Pol II (Grant et al., 1997). SAGA complex also contains Spt proteins including Spt3 which interact with the TATA-binding protein (Eisenmann et al., 1992). There are two major classes of HATs: type-A and

type-B. The type-B HATs are predominantly cytoplasmic, acetylating free histones but not those which are already associated with the chromatin. This class of HATs are highly conserved. Type-B HATs acetylate newly synthesised histone H3 K5 and K12, as well as a few lysine residues in histone H3. This pattern of acetylation is important for the deposition of the histones after which the acetylation modifications are removed (Parthun, 2007). The type-A HATs are a more diverse family of HATs than type-B HATs. They can be classified into three main categories depending on the sequence homology and conformational structure: GNAT, MYST and the CBP/p300 families (Hodawadekar and Marmorstein, 2007). Confirmed and putative HAT proteins have been identified from various organisms from yeast to humans, and they include Gcn5-related N-acetyltransferase (GNAT) superfamily members Gcn5, PCAF, Elp3, Hpa2, and Hat1; MYST proteins Sas2, Sas3, Esa1, MOF, Tip60, MOZ, MORF, and HBO1; global coactivators p300 and CREB-binding protein; nuclear receptor coactivators SRC-1, ACTR, and TIF2; TATA-binding protein-associated factor TAF(II)250 and its homologs; and subunits of RNA polymerase III general factor TFIIC (Sterner and Berger, 2000).

There are at least two well characterised HAT complexes in yeast, the SAGA (**S**pt-**A**da-**G**cn5-**A**cetyltransferase) complex the NuA4 complex (**N**ucleosome **a**cetyltransferase of histone **H4**) (Figure 1.6). The NuA4 and NuA3 belong to the same family of complexes and are named depending on substrate specificity (Allard et al., 1999). Gcn5 is the catalytic subunit of the SAGA complex while Esa1 (**E**ssential **S**AS-2 related **a**cetyltransferase) is the catalytic subunit of the NuA4 complex.



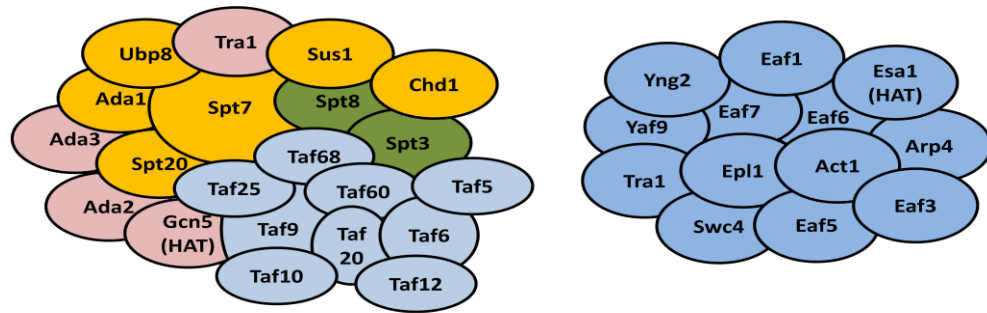

**The yeast SAGA complex**

The yeast SAGA complex contains Gcn5 as its HAT catalytic subunit. SAGA has been shown to interact with acidic activation domains, and this function may be mediated by its adaptor components (Ada2, Ada3, and Gcn5) or possibly through Tra1 or other subunits. Another subset of SAGA proteins (Ada1, Spt7, and Spt20/Ada5) are required for its structural integrity and overall function. The Spt3 and Spt8 subunits have been implicated in interaction with TBP, and the Taf<sub>ii</sub> group, which also participate in TFIID, may provide TBP-binding function to SAGA as well (updated after Sterner and Berger, 2000).

**The yeast NuA4 complex**

The yeast NuA4 complex exists as either a coactivator complex which acetylates gene promoter regions to activate transcription or a smaller Piccolo complex which affects global histone acetylation level (Boudreault et., 2003).

**Figure 1.6 The yeast SAGA and NuA4 complexes** The figure shows the different subunits identified in the SAGA and the NuA4 complexes

The Ada2/Ada3/Gcn5 and Piccolo NuA4 complexes are functionally sufficient for the nucleosomal HAT activity of the megadalton SAGA and NuA4 complexes. Gcn5 is the catalytic HAT subunit of SAGA, but acetylates only histone tails weakly, whereas the Ada2/Ada3/Gcn5 is sufficient to form a subcomplex with similar robust HAT activity and histone H3 and H2B specificity for nucleosomal histones as the full megadalton SAGA complex. Similarly, Esa1 is the catalytic subunit of the NuA4 complex with weak activity on free and nucleosomal histones, but the Piccolo NuA4 subcomplex comprised of the Epl1, Yng2 and Esa1 subunits acetylates nucleosomal histones with the same preference for histones H4 and H2A as the full NuA4 complex (Figure 1.7) (Barrios et al., 2007).

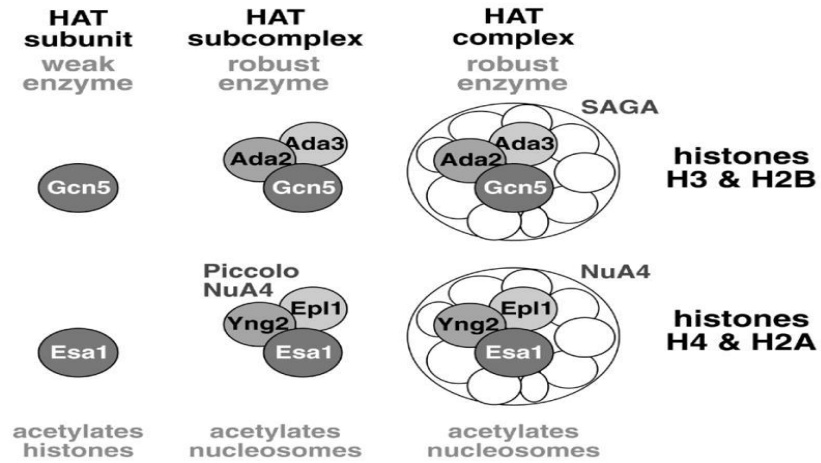

**Figure 1.7 Functional attributes of the SAGA and the NuA4 complexes** The figure has been taken from the research article by Barrios and colleagues (Barrios et al., 2007).

The NuA4 and SWR1-C chromatin-modifying complexes alter the chromatin structure through 3 distinct modifications in yeast: post-translational addition of chemical groups, ATP-dependent chromatin remodelling, and histone variant incorporation (Lu et al., 2009). Fractionation of yeast cell extracts showed the presence of Esa1 in the presence of NuA4. Combined biochemical and genetic data indicate that the Piccolo complex is responsible for a global acetylation pattern in yeast in contrast to activator-directed acetylation at the active gene promoters by the NuA4 coactivator complex (Boudreault et., 2003).

<b>SAGA/SLIK complex Biological function component (this table has been taken from the article by Baker and Grant, 2007).</b>	
Gcn5 (Ada4)	Acetylation of lysines on H3 and H2B; transcriptional activation; NER recognition of acetylated lysine via bromodomain
Ada1	Complex stability
Ada2	Required for nucleosomal acetylation by Gcn5
Ada3	
Spt3	TBP interaction, transcriptional repression at <i>HIS3</i> and <i>ARG1</i> loci
Spt8	

Spt7	Complex stability
Spt20 (Ada5)	
TAF5	Structural integrity of complex and interaction with basal transcription machinery
TAF6	
TAF9	
TAF10	
TAF12	Required for nucleosomal acetylation by Gcn5 and interaction with transcriptional activators
Tra1	Interaction with transcriptional activators
Ubp8	Deubiquitylation of H2B Lys 123; transcriptional activation
Rtg2	SLIK stability; links complex to retrograde response pathway
Chd1	Recognition of H3 Lys 4 methylation via chromodomain; potentiation of histone acetylation by Gcn5
Sus1	mRNA export
Sgf11	Required for association of Ubp8 and Sus1 with SAGA
Sgf29	?
Sca7	Poly(Q) expansion inhibits nucleosomal acetylation by Gcn5

**Table 1.3 The SAGA/SLIK complex biological function component (this table has been taken from the article by Baker and Grant, 2007).**

Yeast Gcn5 acetylates H3 K14, a modification correlated with transcriptional activation (Brownell et al., 1996; Howe et al., 2001; Lo et al., 2000; Syntichaki et al., 2000; Trievel et al., 1999). In *S. pombe*, Gcn5 has been shown to be critical for maintaining genome wide acetylation levels in the transcribed regions of highly expressed genes. Gcn5 also antagonistically regulates these genes with the Class- II HDAC Clr3 (Johnsson et al, 2009). Gcn5 and Gcn5-dependent acetylation of histone H3 K14 tends to be more common in the upstream regions of genes that require Gcn5 for correct expression compared to genes that are independent of Gcn5. This suggests a critical role of Gcn5 in the transcriptional initiation of these genes (Johnsson and Wright, 2010). The Gcn5 and

Rpd3 enzymes are general regulators of histone acetylation, but have been shown to have affinity for specific lysine residues. For example, Gcn5 preferentially acetylates H3 K14 and lysines 8 and 16 of histone H4 (Kuo et al., 1996), and the Rpd3 HDAC preferentially deacetylates lysines 5 and 12 of histone H4 (Rundlett et al., 1996; Tauton et al., 1996). In addition, HATs differ in their ability to act on nucleosomal or free histones, and in this regard, the recombinant form of the enzyme can differ dramatically from the HAT complex that exists in cells. For example, recombinant Gcn5 can only acetylate free histones, whereas the Gcn5 in SAGA complex can acetylate core histone N-terminal lysines (Grant et al., 1997).

Work on yeast Gcn5 and Rpd3 suggests that lysines in the N-terminal tails of core histones are physiologically relevant substrates for these enzyme complexes, and that the histone acetylase and deacetylase activities are critical for transcriptional regulation. Studies of bulk acetylation levels have shown that up to 13 of the 30 lysine tail residues in the histone core octamer are acetylated (Roth et al., 2001). So far, no body of evidence has been generated which suggests an order in which chromatin remodelling complexes and chromatin remodifiers function during gene regulation. Rather data suggest that each individual promoter uses a specific set order of function of these complexes for transcriptional activation or repression. It has also been shown that there is a strict correlation between histone acetylase activity *in vitro* and transcriptional activity *in vivo* (Kuo et al., 1998; Wang et al., 1998). In one of these studies, histone acetylation by the various Gcn5 derivatives was performed in the context of the Ada and SAGA complexes on nucleosomal substrates (Wang et al., 1998). In the other study, additional evidence for physiological relevance was obtained by analyzing directly the acetylation state of chromatin in yeast cells (Kuo et al., 1998). Data from these two studies revealed that when overexpressed, Gcn5 leads to increased acetylation of core histones. More interestingly, Gcn5 increases promoter histone acetylation in a manner that correlates with Gcn5-dependent transcriptional activation and histone acetylase activity *in vitro*.

Histones are also physiological substrates for yeast Rpd3 and Hda1 histone deacetylases (Rundlett et al., 1996). As would be predicted from the enzymatic specificities of these deacetylases, yeast strains lacking either Rpd3 or Hda1 show increased acetylation at lysines 5 and 12 of histone H4. Furthermore, it has also been shown that catalytically inactive mutants of an enzyme complex still maintain the structural integrity of the complex. For example, single mutant derivatives of Rpd3, H150A, H151A and H188A that abolish histone deacetylase activity do not affect Sin3–Rpd3 complex formation but are defective for transcriptional repression *in vivo* (Kadosh and Struhl, 1998).

Histone acetyltransferases and deacetylases cause localized fluctuations of chromatin structure because they are targeted generally or during a specific stimulus to the promoters.. At present, there is virtually no information on the localization of modified chromatin *in vivo*. It is not known so far whether these two enzymes modify a single nucleosome or if the chromatin structure is affected over a larger distance. In addition, the histone acetylases and deacetylases differ with respect to the individual lysine residues and specific histones that are affected, and there is limited information on how such differences affect chromatin structure and protein accessibility *in vivo* (Struhl, 1998).

Local perturbations of chromatin structure are expected to specifically affect the accessibility and/or function of transcriptional regulatory proteins that bind DNA sequences in the region where histone acetylation or deacetylation occurs (Struhl, 1998). However, accessibility to the promoter is also influenced strongly by the inherent ability of a given DNA-binding protein to bind nucleosomal templates (Hassig et al. 1997; Laherty et al. 1997, Kadosh and Struhl 1997, Nagy et al. 1997), the inherent positioning of nucleosomes on particular promoter DNA sequences, the intracellular levels of the DNA-binding proteins and the inherent quality of the binding site and competition between binding sites in promoter regions and those located throughout the genome (Struhl, 1998).

### 1.1.3 Nucleosomal lysine acetylation- site for protein-protein interaction domains

Lysine acetylation when first discovered was thought to neutralise the positive charge on the histones, thus reducing the affinity between the histone and negatively charged DNA. Recent studies have shown that lysine acetylation of the core nucleosomal histones as well as the other posttranslational modifications of histones generate binding sites for specific protein-protein interaction domains. Numerous chromatin associated factors have been shown to specifically interact with posttranslationally modified histones via distinct domains. Use of new proteomic approaches have revealed that there are multivalent proteins and complexes that have specific domains within them that allow the simultaneous recognition of several modifications and other nucleosomal features (Vermeulen et al., 2010; Bartke et al., 2010). These domains are part of protein complexes and are important in recognising modifications for gene regulation. A few known protein domains are described in the following section.

A protein domain is part of the protein sequence and structure which can evolve, function and exist independently of the rest of the protein chain.

- A bromodomain (BRD) is a protein domain that can recognise acetylated lysine residues such as those on the N-terminal tails of core histones. This recognition is often a prior condition for an enzyme complex and histone interaction (Owen et al., 2000). The bromodomain was identified as a novel structural motif by John W. Tamkun and colleagues while studying the *BRM (brahma)* gene, and showed sequence similarity to genes involved in transcriptional activation (Tamkun et al., 1992).
- A chromodomain (chromatin organization modifier) is a protein structural domain of about 40-50 amino acid residues commonly found in proteins associated with the remodeling and manipulation of chromatin (Messemer et al., 1992). The chromodomains bind to methylated lysines (Nielsen et al., 2002; Jacobs and Khorasanizadeh, 2002).

- The PHD finger (**P**lant **H**omeo **D**omain) was discovered in 1993 as a Cys<sub>4</sub>-His-Cys<sub>3</sub> motif in the homeodomain protein HAT3 in *Arabidopsis thaliana* (Schindler et al., 1993). The PHD finger motif resembles the metal binding RING domain (Cys<sub>3</sub>-His-Cys<sub>4</sub>) and FYVE domain. It occurs as a single finger, but often in clusters of two or three, and it also occurs together with other domains, such as the chromodomain and the bromodomain.
- RING (**R**eally **I**nteresting **N**ew **G**ene) finger domain is a protein structural domain of zinc finger type which contains a Cys<sub>3</sub>HisCys<sub>4</sub> amino acid motif which binds two zinc cations (Freemont et al., 1991; Lovering et al., 1993). Many proteins containing the RING domain play a key role in the ubiquitination pathway.

Histone acetylated lysines are bound by bromodomains, which are often found in HATs like Gcn5 and chromatin remodelling complexes (Mujtaba et al., 2007). These bromodomains, about 110 amino acid residue structures recognize several of the residues flanking the acetyl-lysine, thereby providing acetyl-lysine recognition within a sequence context (Hudson et al., 2000; Mujtaba et al., 2002; Owen et al., 2000). For example, Swi2/Snf2 contains a bromodomain that targets it to histones which are acetylated. In turn, this recruits the SWI/SNF remodelling complex, which functions to 'open' the chromatin (Hassan et al., 2002). Recently, it has also been shown in mammalian cells that PHD fingers are capable of specifically recognizing acetylated histones. The DPF3b protein is a component of the BAF chromatin remodelling complex and it contains tandem PHD fingers that are responsible for recruiting the BAF complex to acetylated histones (Zeng et al., 2010). Other complexes that rely on bromodomains for their full function include chromatin remodelers, which use the energy of ATP hydrolysis to move and/or eject nucleosomes to uncover the underlying DNA (Cairns, 2005). Important initial work demonstrated that bromodomains present on the yeast remodeler SWI/SNF are important for recruitment of the remodeler on acetylated chromatin templates. This is consistent with a role for bromodomains in targeting enzyme complexes to histones (Hassan et al., 2002, 2006). The paralog of yeast Swi/Snf

is the 15 subunit Rsc complex, which is both abundant and essential in *S. cerevisiae* (Cairns et al., 1996) and is involved in multiple chromosomal processes including transcriptional regulation, DNA repair, stress response, and chromosome cohesion and segregation (Angus-hill et al., 2001; Baetz et al., 2004; Cairns et al., 1999; Chai et al., 2005; Chang et al., 2005; Yukawa et al., 1999). Importantly, RSC subunits contain 8 of the 15 bromodomains in *S. cerevisiae*, indicating that histone acetylation likely plays a central role in recruiting RSC to chromatin and/or in regulating its remodeling activity. Consistent with this notion, acetylation of histones promotes nucleosome remodeling by RSC and the passage of RNA polymerase II through chromatin *in vitro* (Carey et al., 2006).

#### **1.1.4 Lysine acetylation, chromatin dynamics and stress responses**

Literature on lysine acetylation and chromatin dynamics between the years 1990 and 2000 provided experimental validation that posttranslational modifications like lysine acetylation was an essential requirement for DNA template related molecular processes. It was also the time period when a number of critical discoveries were made regarding protein complexes and regulators which played a major role in chromatin dynamics. There was a paradigm shift in our understanding of how the chromatin was regulated through acetylation from the year 2000 onwards. Previous work suggested that posttranslational modification was required to maintain overall genome stability, acetylation and other modifications are now seen as a molecular fulcrum controlling healthy and diseased states. The fundamental marking on histones by covalent modification and recognition by specific domains has been termed “the histone code” (Fischle et al., 2003; Strahl and Allis, 2000). These binding domains reside on both chromatin regulators and transcriptional regulators. Thus, most factors are targeted to particular locations in the genome



by one of two mechanisms: through interactions with site-specific DNA binding proteins or by using specialized domains to interact with modified histones (Kouzarides, 2000).

In the early 1990's it was shown that highly transcribed genes correlated with high acetylation levels and silencing of genes required hypoacetylation. For example, it was shown that chromosomal regions which undergo prolific transcription often have hyperacetylated histones while the heterochromatinized silent regions are hypoacetylated (Turner, 1993). Some examples where an increased histone H4 acetylation levels have been observed were in the actively transcribed chicken globin gene (Hebbes et al., 1992), human platelet derived growth factor gene (Clayton et al., 1993), and the *Drosophila* male X chromosome (Bone et al., 1994). On the contrary histone H4 was observed hypoacetylated at specific lysine residues 5,8 and 16 in human (Jeppesen and Turner, 1993) and yeast (Braunstein et al., 1993). However it has been reported that in *Drosophila* (Turner et al., 1992) and yeast (Braunstein et al., 1996), the H4 K12 is hyperacetylated even in the heterochromatin. Recent reports have suggested that the H4 K12 acetylation regulates telomere heterochromatin. The NuA4 HAT binds to silent telomeric regions and prevents overaccumulation of Sir proteins (Zhou et al, 2011). Moreover, elimination of the H4 K12 acetylation caused defects in multiple telomere-related processes like transcription, telomere replication and recombination (Zhou et al, 2011). For transcriptional silencing in budding yeast, the evolutionarily conserved lysine deacetylase Sir2, in concert with its partner proteins Sir3 and Sir4, establishes a chromatin structure that prevents RNA polymerase II (Pol II) transcription. One mechanism by which Sir2 propagates silencing of gene transcription is by targeting the transition between RNA pol II initiation and elongation (Gao and Gross, 2008).

A crosstalk between different modifications is essential for transcriptional activation. For example, in *S.cerevisiae* and *S.pombe*, the H3 K4 acetylation and H3 K4 methylation are both interdependent and critical on active gene promoters (Guillemette et al., 2011; Xhemalce and Kouzarides, 2010). In *Saccharomyces cerevisiae*, genetic experiments indicate that H3 K4

methylation functions in diverse cellular processes that include transcription, DNA repair, meiotic differentiation, and silencing at telomeres and rDNA (Dehe and Geli, 2006). Similarly, deacetylation and methylation are also intrinsically linked as indicated in the literature. Pho23 and Cti6, two PHD-containing proteins, cooperatively anchor the large Rpd3 (Rpd3L) complex to the H3 K4-methylated *PHO5* promoter and the deacetylation activity of Rpd3 on histone H3 is required for the function of Set1 methylase at the *PHO5* promoter in yeast. The H3 K4 hypermethylation in turn prevents aberrant nucleosome remodelling at the *PHO5* promoter (Wang et al., 2011). Dimethylation of H3 K4 by Set1 histone methyltransferase recruits the Set3 histone deacetylase complex to 5' transcribed regions (Kim and Buratowski, 2009).

Chromatin remodellers and other associated proteins not only have a general functional role but specifically tend to affect histone modifications and are critical for gene regulation. Deletion of *SPT6*, a chromatin remodeller, reduced levels of H3 K9 trimethylation, elevated levels of H3 K14 acetylation, reduced recruitment of several silencing factors, and defects in heterochromatin spreading suggesting that it plays roles during transcription and post-translational events (Kiely et al., 2011). In yeast, it has been shown that Gcn5p subunit of the SAGA complex preferentially acetylates histone H3 K18 on the gene promoters and that Gcn5p activity is required for removal of histone H3 from one of the promoters (van Oevelen et al., 2006). In mammalian cells, the transcriptional coactivator and acetyltransferase, CREB-binding protein behaves synchronously with acetylation patterns specific for H3 K18 and H3 K23 during porcine oocyte first meiotic division (Xue et al., 2010). Thus experimental analyses from various literature studies indicate that the H3 K9 and H3 K18 are important lysine substrates for a number of chromatin protein complexes. Moreover, in plants, specifically the H3 K18 and H3 K23 on differential histone modification are associated with the removal and the regeneration of the cell wall (Tan et al., 2011). The Sir2 deacetylase which regulates chromatin silencing and lifespan in *S.cerevisiae* is specifically a H3 K9 deacetylase modulating the telomeric chromatin (Michishita et al., 2008). The

rice *SIR2*-like gene is required for safeguard against genome instability and cell damage by regulating H3 K9 acetylation and methylation in order to ensure plant cell growth (Huang et al., 2007).

On exposure to stressing agents, in mammalian cells however, for instance, in presence of genotoxic agents causing DNA damage result in an increase in H3 K56 and H4 K16 acetylation levels but not the H3 K9 levels (Vempati, 2011). Epigenetic modifications induced by a cell cycle activator in colon cancer is shown to have an increase in acetylation for histones H2B lysine 5 (H2B K5), H2B K15, H3 K9, H3 K18, and H4 K8 and a decreased trimethylation of H3 K27 (Vlaicu et al., 2010). It has also been shown that lower global or cellular levels of H3 K4 dimethylation and H3 K18 acetylation predict a high risk of prostate cancer reoccurrence (Seligson et al, 2009). In another study it was shown that the corresponding nuclear global expression levels in moderate to well differentiated tumors for H4 K12 and H3 K18 acetylation were increased while these levels were decreased in poorly differentiated tumors. In addition, *HDAC2* expression was correlated significantly with progression of adenoma to carcinoma suggesting *HDAC2* expression is significantly associated with colon adenoma and carcinoma progression (Ashktorab et al., 2009). The acetylation status of cardiac histones in mice affected by hemorrhage is modulated by resuscitation and causes increase in acetylation at a large number of lysine sites, predominantly histone H3 (Alam et al., 2008).

Although the effects of histone acetylation and deacetylation are essentially viewed in terms of promoter accessibility, experimental evidence indicates that effect of histone acetylation and deacetylation serves as signals for interaction with proteins. For example, the transcriptional repression domain of the Tup1 corepressor interacts with hypoacetylated forms of histones H3 and H4 (Edmondson et al., 1996). In cases where histone acetylation or deacetylation is targeted, recognition of such signals by relatively general chromatin-associated proteins could lead to local chromatin structures that differ considerably from that of bulk chromatin. For example, H4 K12 is

preferentially acetylated in transcriptionally silent heterochromatin (Braunstein et al. 1996), and Rpd3 histone deacetylase counteracts heterochromatic silencing in yeast and flies (Derubertis et al., 1996; Vannier et al., 1996). These observations are surprising because, in striking contrast to the usual correlation, histone acetylation is associated with decreased transcriptional activity. In addition, it has been shown that H3 K56 modification is required for efficient transcription of heterochromatic locus by RNA pol II (Varv et al., 2010). It has also been shown that Gcn5 and SAGA complex, proteins usually associated with actively transcribed genes are involved in maintaining the telomeric regions (Atanassov et al., 2009). The SAGA complex subunit Ada2, has been shown to be positioned at the chromosome termini and to participate in both transcriptional repression and activation in response to nutrient signalling (Jacobson and Pillus, 2009). In accordance with such diverse and unorthodox roles of Gcn5 and SAGA complex in maintaining telomere structure and regulating the chromosomal termini, recent reports suggest that the Rpd3 HDAC is associated with transcriptional activation of genes.

### **1.1.5 Rpd3 HDAC and its role in transcriptional activation of genes**

The Rpd3 HDAC is a well characterised HDAC in yeast. It has been shown to repress genes involved in meiosis, arginine metabolism, enhanced heterochromatin silencing, enhanced rRNA silencing, mating type locus (Kadosh and Struhl, 1997; Rundlett et al., 1996; Dorland et al., 2000; Vannier et al., 1996; Smith et al., 1999; Sun and Hampsey., 1999; Schröder et al., 2004) and has been shown to act as global repressor of a large number of other genes in the yeast genome (Kurdistani et al., 2002). Rpd3 was shown to be associated with promoters involved in actively transcribing genes and also reveals new sites within the yeast genome where Rpd3 function was not previously known (Kurdistani et al., 2002). It has been shown previously that the Rpd3 complexes associate with DNA-binding repressors such as Mad (Hassig et al. 1997; Laherty et al.

1997), Ume6 (Kadosh and Struhl 1997), YY1 (Yang et al. 1996a), or with transcriptional corepressors for nuclear receptors such as SMRT (Nagy et al. 1997) and NCoR (Alland et al. 1997; Heinz et al. 1997). Despite the known role of Ume6 in Rpd3 recruitment, it was shown by Kurdistani and colleagues that only a limited of genes targeted by Rpd3 are also associated by Ume6. This indicated that Rpd3 was brought to many promoters by other recruiters (Kurdistani et al., 2002). In 2005, the discovery was made that Rpd3 exists as two complexes, the Rpd3 large and small complex. Figure 1.8 shows that the Rpd3L complex is associated with promoter driven transcriptional repression while the Rpd3S complex regulates gene transcription by suppressing cryptic transcript initiation (Carrozza et al., 2005; Keogh et al., 2005).

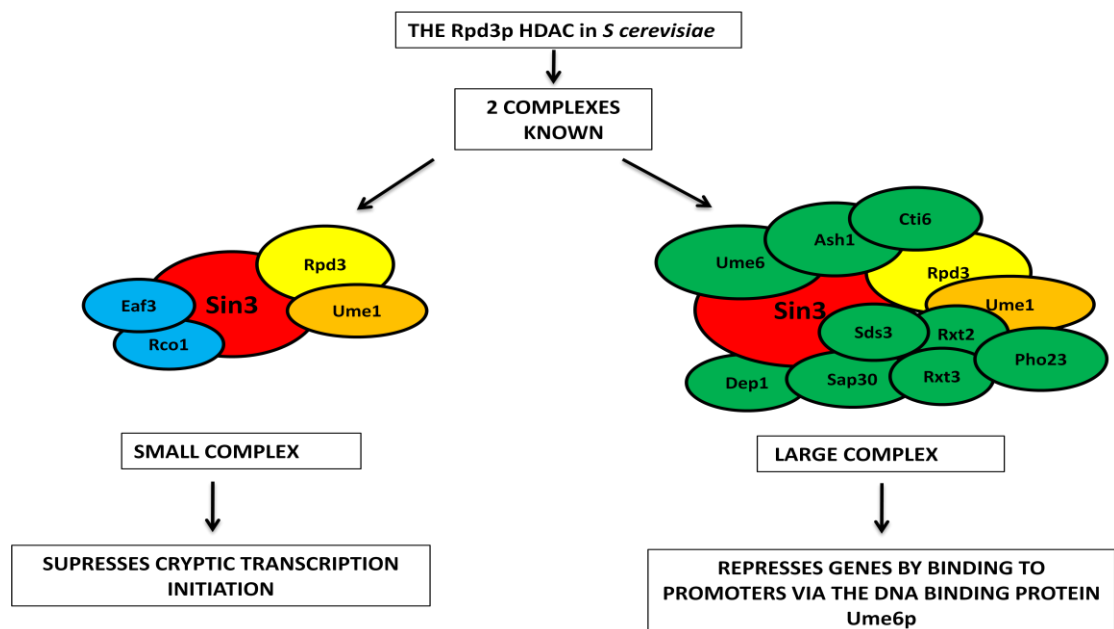

**Figure 1.8 Role of the two Rpd3 complexes in transcriptional regulation in *S. cerevisiae*** A representative diagram of the two known Rpd3 complexes in yeast and their function in gene regulation. The two complexes have Rpd3, Sin3 and Ume6 common to them shown in yellow, red and orange colour respectively. Eaf3 and Rco1 (in blue) are specific to the small complex and the subunits highlighted in green colour are members specific to the large complex.

Traditionally, the Rpd3 HDAC has been shown to repress various subsets of genes and has been credited as being a global repressor in yeast as described before. Surprisingly however, in the past

seven years (2004-2011), the Rpd3 large complex has been associated with the activation of a large number of genes in stress responses (Bumgarner et al., 2009; Sertil et al., 2007; Sharma et al., 2007; Xin et al., 2007; Alejandro-Osorio et al., 2009; de Nadal et al., 2004; Mas et al., 2009). The first report came from deNadal and colleagues in 2004, when they demonstrated that the Hog1 MAPK recruits the Rpd3 HDAC to GSR osmoresponsive genes during hyperosmotic stress. Promoter deacetylation by Rpd3 was proposed to activate the GSR genes *ALD3* (Aldehyde dehydrogenase 3), *CTT1* (Catalase T 1), *HSP12* (Heat shock protein 12), *STL1* (Sugar transporter like protein 1) and *GRE2* (Genes de Respuesta a Estres -Genes responsive to stress 2) (deNadal et al., 2004). Three more reports in the year 2007 showed that Rpd3 is involved in the transcriptional activation of genes other than the GSR genes. Rpd3 was shown to induce the anaerobic *DAN1* (Delayed anaerobic 1) and *TIR* (Tlp1-related 2) genes. The Swi/Snf chromatin remodelling complex was also shown to be involved in regulating *DAN1* expression (Sertil et al., 2007). The other paper in 2007 showed that Rpd3 along with Hos2, another HDAC were involved in activating DNA damage-inducible genes *RNR3* (Ribonucleotide reductase 3) and *HUG1* (Hydroxyurea, UV and gamma radiation induced) (Sharma et al., 2007). Surprisingly the activation of *RNR3* was independent of the Tup1 corepressor complex. Both these papers strongly emphasise the role of RNA polymerase holoenzyme associated activation via Rpd3 (Sertil et al., 2007; Sharma et al., 2007) but do not demonstrate the mechanism of Rpd3 associated activation of the genes. Rpd3 was also shown to activate *HAP1* (Heme activator protein 1) along with other known HDACs (Xin et al., 2007). Rpd3 was also shown to be required for transient changes in genome expression in response to salt, peroxide and temperature stress (Alejandro-Osorio et al., 2009). Rpd3 was also shown to positively regulate the non coding RNA which in turn controls the variegated gene expression in yeast (Bumgarner et al., 2009).

Literature mentioned above indicates that Rpd3 HDAC does regulate expression of a large number of genes in response to various abiotic and chemical stresses. In spite of having a positive role of

activating various subsets of genes under different stress responses, the mechanism of gene activation by Rpd3 in stress responses still remains unknown. A study by deNadal and colleagues first identified the positive role of Rpd3 under osmotic stress response (deNadal et al., 2004). A mechanism of how Rpd3 regulates gene expression with a bZIP transcription factor Hac1 under ER stress is known (Schröder et al., 2000 and 2004). Thus various stress responses seem to be a common denominator through which Rpd3 either positively or negatively regulates gene expression. Hence it is plausible that Hac1 interacts with Rpd3 to activate a large set of genes in the environmental stress response. This also raises the possibility of a mechanism of signal integration between two different stress pathways such as ER stress and osmotic stress via the Rpd3 HDAC and bZIP transcription factor Hac1p.

Section 1 of the introduction chapter presents an overview of chromatin structure and regulation of gene expression. The experimental evidence defines a role of Rpd3 HDAC as a positive and negative regulator of gene expression. Hac1p and Rpd3p have been shown previously to interact together under nutritional stress (Schröder et al., 2000 and 2004). The following part of introduction will discuss the response of *S. cerevisiae* to nutritional stress and the role of Rpd3 HDAC and bZIP transcription factor Hac1 in the ER stress response.

## **1.2 Nutrient requirement and growth pattern in *S. cerevisiae***

The way yeasts respond to nutrient availability has various physiological outcomes. Whether yeast takes the sporulation pathway or the pseudohyphal growth pathway is controlled by nutrient availability, cell type and environmental factors. The diploid yeast *S. cerevisiae*, in the presence of nitrogen and fermentable carbon sources, maintains vegetative growth. In absence of nitrogen and fermentable carbon sources, the diploid yeasts sporulate (Kupiec et al., 1997), a mechanism through which they remain dormant until conditions are favourable again to maintain vegetative

growth. Absence of nitrogen but presence of fermentable carbon induces pseudohyphal growth (Gimeno et al., 1992). Thus, different stress responses allow yeast to exhibit various physiological conditions. The process of sporulation requires meiotic divisions and meiosis in turn to produce four spores. Four spores together form a tetrad (Figure 1.9). The process of meiosis requires a transcriptional activity of nearly 1000 genes and can be divided into three major stages: early, middle and late. Each stage is characterised by the expression of a specific subset genes required for meiosis (Chu et al., 1998). In *S. cerevisiae*, the cascading effect of genes called *Early Meiotic Genes (EMGs)*, a set of preliminary genes for meiosis (Mitchell, 1994), initiate a transcriptional program which eventually results in the physiological response of spore formation.

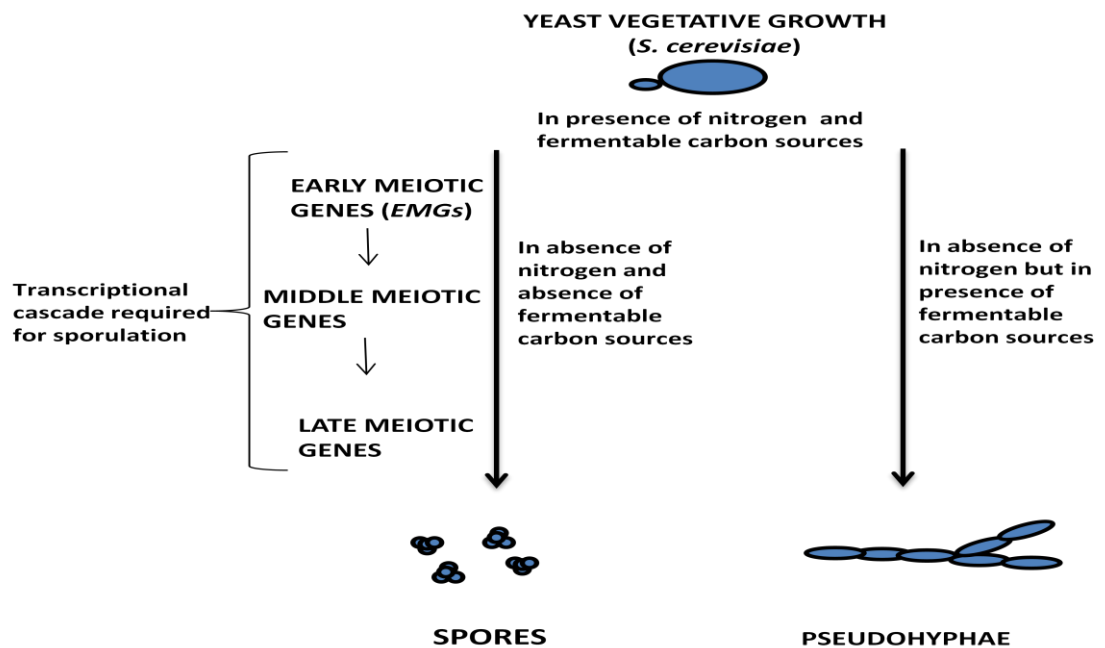

**Figure 1.9 A diagram showing growth pattern of yeast growth in presence or absence of carbon and nitrogen sources**

### 1.2.1 A link between nutrient nitrogen availability and ER functionality in yeasts

Many carbon and nitrogen sources are metabolised by yeast to maintain cellular processes. For example, fermentable sugar provided in the media is taken up by yeasts for glucose metabolism.



Similarly, nitrogen provided in the media results in a sufficient pool of amino acids, building material of proteins. An organelle whose function is to maintain protein homeostasis is the Endoplasmic Reticulum (ER). This organelle is a cytoplasmic membranous network of branching tubules and flattened sacs present in all eukaryotes. It is the principal site for protein and lipid biosynthesis. Together with the Golgi complex, the ER facilitates the transport and release of correctly folded proteins to their respective target locations in a cell.

### **1.2.2 The Unfolded Protein Response (UPR)**

Disruption of protein folding in the ER activates a signalling network, collectively called the Unfolded Protein Response (UPR). The cells respond to this ER stress through a signal transduction pathway that transduces the signal of unfolded or misfolded proteins from the ER lumen to the nucleus (Schröder and Kaufman, 2005). The UPR response is elicited to maintain protein homeostasis within a cell by balancing protein folding capacity and the unfolded protein cargo on ER. Upregulation of chaperone gene expression is one of the essential outcomes of activating the UPR pathway. There are four main activities which the UPR performs in order to alleviate unfolded or misfolded protein stress and these are as follows (Schröder and Kaufman, 2005):

1. The UPR increases synthesis of ER resident molecular chaperones and foldases.
2. The UPR stimulates phospholipid synthesis which results in ER expansion and dilution of the unfolded protein load.
3. Transcription of genes encoding secretory proteins and general translation is inhibited.
4. The clearance of slowly folding proteins from the ER is upregulated by stimulating ER associated degradation (ERAD).

The UPR pathway when activated controls the transcriptional regulation of 381 open reading frames in yeast. Nearly 50% of ORFs are known to function in the secretory pathway, but still ~100 ORFs regulated by UPR, have other known functions unrelated to secretory pathway, indicating that they may be related to other cellular processes (Travers et al., 2000). One function of UPR is control of differentiation responses in *S. cerevisiae*. The UPR or the ER stress pathway is a well characterised pathway in yeast and mammalian cells. In the following introduction section a brief overview of known mechanisms by which the UPR operates in mammalian cells will be presented after which the UPR pathway in *S. cerevisiae* will be discussed.

#### **1.2.2.1 Mechanisms of signal transduction by the UPR in mammalian cells**

Four principal mechanisms of signal transduction by the UPR have been identified. In mammalian cells the UPR signalling pathways are initiated through three ER resident transmembrane protein sensors: PERK (double stranded RNA-dependent protein kinase (PKR)- like ER kinase), *IRE1* (Inositol requiring 1) and *ATF6* (Activating transcription factor 6). There is a fourth mechanism for UPR activation in mammalian cells by the activation of procaspase-12 which activates a caspase cascade to promote apoptosis ((Hetz et al., 2006; Nishitoh et al., 2002; Urano et al., 2000; Yoneda et al., 2001). A brief description of the other three pathways in mammalian cells (Figure 1.10) is described below:

1. **The PERK pathway-** PERK is an ER type one transmembrane serine/threonine protein kinase that has three domains for recognising and processing the unfolded proteins. The luminal domain acts as a sensor for the unfolded proteins. The transmembrane domain is embedded in the ER membrane and a cytosolic domain transmits signals to downstream effectors. In the inactive state the luminal domain of the protein is bound to the ER resident chaperone BiP. During ER stress, BiP releases from the luminal domain leading to

activation through oligomerization and autophosphorylation and leading to activation of its cytosolic kinase domain (Bertolotti et al., 2000; Liu et al., 2003; Ma et al., 2002; Ron and Walter, 2007; Schröder and Kaufman, 2005; Yoshida, 2007). PERK activates the Cap 'n' Collar bZIP transcription factor NRF2, which activates genes for antioxidant response. In addition, PERK phosphorylates the  $\alpha$ -subunit of the eukaryotic translation initiation factor 2 (eIF2 $\alpha$ ) (Harding et al., 1999; Schröder and Kaufman, 2005).

2. **The *IRE1/ HAC1* pathway-** Ire1p, is the second sensing molecule in the ER membrane and is a serine/threonine protein kinase endoribonuclease which like the PERK has two domains. The ER lumen has the transmembrane domain while the two cytosolic domains are the kinase domain and endoribonuclease domain. The protein is conserved in all eukaryotes and in mammals the Ire1p has two isoforms, Ire1 $\alpha$  and Ire1 $\beta$ . Ire1 $\alpha$  is a ubiquitous protein expressed in all tissues while the Ire1 $\beta$  is localised to the epithelial cells of the gastrointestinal tract. The inactive state of Ire1 is also maintained by the BiP binding to the luminal domain. Close contacts between the cytosolic domains result in the trans-autophosphorylation and activation of the ribonuclease domain. The activated Ire1 $\alpha$  ribonuclease domain cleaves the *XBP1* (X-box binding protein 1) constitutively transcribed pre-mRNA into a mature mRNA by an unconventional splicing mechanism. The *XBP1* mRNA has two conserved overlapping ORFs. On UPR activation, Ire1 $\alpha$  removes a 26- nucleotide intron from the precursor *XBP1* mRNA into a functional, mature mRNA which is then translated to form the Xbp1 transcription factor. Unspliced *XBP1*-mRNA (*XBP1<sup>u</sup>*) encodes a short lived protein responsible for repression of these UPR target genes (Yoshida et al., 2006). The splicing of *XBP1* mRNA by Ire1 excises an intron resulting in a frameshift in the *XBP1* transcript (*XBP1<sup>s</sup>*) resulting into Xbp1<sup>s</sup> similar to Hac1<sup>i</sup>p in yeast. *IRE1* is involved in activation of cell death pathways in response to prolonged ER stress by its interaction with tumor necrosis associated factor (TRAF2) to modulate the activity of c-

JUN N-terminal kinase (JNK) pathway via the apoptosis signaling-regulated kinase 1 (ASK-1), which controls apoptosis through caspase-12 activation (Hetz et al., 2006; Nishitoh et al., 2002; Urano et al., 2000; Yoneda et al., 2001). The non-specific Ire1p RNase activity has also been suggested to reduce global reduction of protein into ER by degradation of mRNA localized to the ER membrane (Hollien et al., 2009).

3. **The ATF6 pathway-** Atf6 is a type two transmembrane protein having an ER luminal domain for sensing unfolded proteins and two cytosolic domains namely, a DNA binding domain containing a basic leucine zipper motif and a transcriptional activation domain (Yoshida, 2007). ATF6 translocates to the Golgi complex (Chen et al., 2002), where the site-specific proteases S1P and S2P proteolytically release the cytosolic domain of ATF6 (Haze et al., 1999). This domain is predicted to heterodimerise with XBP1 and localise to the nucleus to activate the ER chaperone genes (Yoshida et al., 2000).

The ER associated protein degradation (ERAD) pathway is also activated when the ER cargo is loaded with unfolded or misfolded proteins (Friedlander et al., 2000; Travers et al., 2000). Synthetic lethality in yeast between UPR and ERAD (Travers et al., 2000) or chaperone machinery (Tyson and Stirling, 2000), and increase in UPR signaling have been reported with defective ERAD in yeast (Cox and Walter, 1996) and mammalian cells (Hori et al., 2004; Lee et al., 2003).

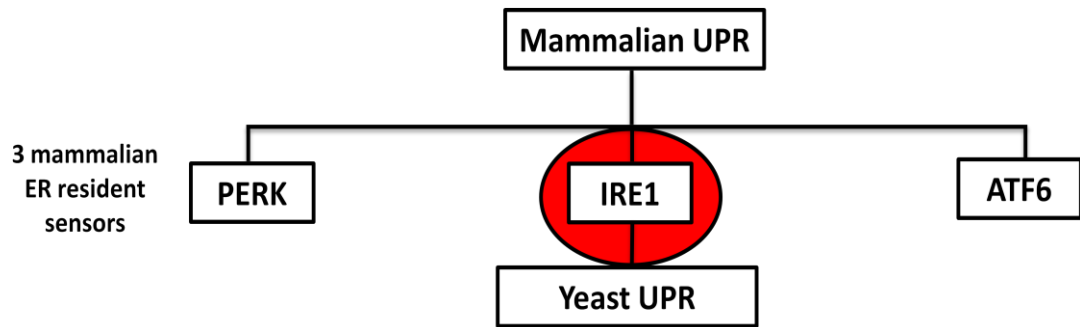

In yeast and filamentous fungi, the IRE1-XBP-1 (Hac1p/HACA) pathway is the only known UPR signal transduction pathway ( Schröder and Kaufman, 2005).

**Figure 1.10 Three mammalian ER resident sensors for misfolded proteins** The *IRE1/XBP1* (Hac1p/HACA) pathway is the only known pathway for UPR in yeast which is common to the mammalian UPR pathway.

#### 1.2.2.2 The mechanism of UPR induction in *S. cerevisiae*

The Ire1p mediated mRNA splicing of *HAC1/XBP1* is conserved from yeast to mammals. In the budding yeast *S. cerevisiae*, Ire1p (Inositol requiring 1) in unstressed conditions is bound to BiP/GRP78/KAR2 chaperones in a monomeric form (Bertolotti et al., 2000; Gardner and Walter, 2011). On an increase of unfolded proteins in the ER, BiP/GRP78/KAR2 binds the unfolded polypeptides, which results in freeing Ire1p from these molecules. Ire1p then oligomerizes and autophosphorylates through its serine threonine kinase domain, activating its RNase domain. Ire1p was shown to form a higher order oligomer to activate response in order to counter the build up of unfolded proteins in ER (Korenykh et al., 2009). The activated Ire1p splices at the 5' and 3' exon-intron junctions of *HAC1* messenger RNA (mRNA). *HAC1* mRNA then encodes Hac1<sup>i</sup>p, a basic leucine zipper transcription factor (bZIP) (Cox and Walter, 1996; Kawahara et al., 1997). The exons are ligated by transfer RNA ligase Rlg1p (Sidrauski et al., 1996). Recent reports suggest that splicing and release of translational attenuation of *HAC1* mRNA are separable steps and Rlg1p plays specific roles in both these steps (Mori et al., 2010). The induced form of Hac1p, Hac1<sup>i</sup>p ("i" for induced) then activates genes by binding to the consensus sequence, Unfolded

Protein Response Element (UPRE; CAGCGTG) present in the promoters of responsive genes like chaperone genes and activates their transcription (Mori et al., 1996; Mori et al., 1998; Mori et al., 1992). The expressed chaperones help to deal with ER unfolded protein stress. Unspliced *HAC1<sup>u</sup>* mRNA is poorly translated and is unable to activate transcription as efficiently as *Hac1<sup>p</sup>* from spliced *HAC1<sup>i</sup>* mRNA (Chapman and Walter, 1997; Welihinda et al., 2000). The transcriptional activation through UPRE is dependent on the SAGA histone acetyltransferase complex (Welihinda et al., 1997). *Hac1<sup>p</sup>* interacts with *Gcn5p* *in vitro*, the catalytic subunit of SAGA (Welihinda et al., 2000).

### 1.2.2.3 Protective role of UPR beyond ER stress

The UPR is thus a response to protect cells against ER stress. The transcriptional program activated by the UPR not only serves to reduce protein load on the ER by activating chaperones but has been implicated in alleviating metabolic toxicity as well. The UPR has also been shown to have a role in genome maintenance (Henry et al., 2010). In addition, ER stress response has been shown to be an important feature of the Cadmium toxicity but not with Arsenite or Mercury poisoning. The full functionality of the pathways involved in ER stress response is required for  $\text{Cd}^{2+}$  tolerance. Gardarin and colleagues also suggest that  $\text{Cd}^{2+}$ -induced ER stress and  $\text{Cd}^{2+}$  toxicity are a direct consequence of  $\text{Cd}^{2+}$  accumulation in the ER.  $\text{Cd}^{2+}$  also does not inhibit disulfide bond formation but perturbs calcium metabolism. In particular, cadmium activates the calcium channel *Cch1/Mid1*, which also contributes to  $\text{Cd}^{2+}$  entry into the cell (Gardarin et al., 2010). During *C. elegans* development, XBP-1 has been shown to provide an essential role in protecting the host during activation of innate immunity. Activation of the PMK-1-mediated response to infection with *Pseudomonas aeruginosa* induces the XBP-1-dependent UPR. Whereas a loss-of-function *xbp-1* mutant develops normally in the presence of relatively non-pathogenic bacteria, infection

of the *xbp-1* mutant with *P. aeruginosa* leads to disruption of ER morphology and larval lethality (Richardson et al., 2010).

### 1.2.3 Nitrogen availability and *S. cerevisiae* differentiation control via the UPR

The UPR pathway senses nitrogen availability and regulates differentiation of yeast. The splicing of *HAC1* mRNA observed in nitrogen-rich conditions is inhibited under nitrogen starvation. In nitrogen-rich conditions the UPR pathway represses both the pseudohyphal growth and meiosis (Schröder et al., 2000). Overexpression of Hac1<sup>p</sup> also represses pseudohyphal growth and deletion of *HAC1* or *IRE1* derepresses pseudohyphal growth. Thus Hac1p is synthesized in response to nitrogen-rich environment and negatively regulates nitrogen starvation responses. A model of a UPR-signaling pathway that senses the nutritional state of the cell and regulates nitrogen starvation induced differentiation responses, was suggested by Schroder et al, 2000 and is shown in Figure 1.11. The model proposed that splicing of *HAC1* mRNA in response to extracellular nitrogen may be due to increased protein synthesis leading to high levels of newly synthesized unfolded polypeptides in nitrogen-rich conditions compared to nitrogen-starved conditions and this activates the UPR by splicing of *HAC1* mRNA. Conversely under nitrogen starved conditions when the rate of protein synthesis is lower, thereby decreasing the ER load, this leads to Ire1p inactivation and thereby results in no Hac1<sup>p</sup> synthesis. Thus the UPR plays a role in nutrient sensing and controlling differentiation events in yeast.

Healthy cells under nutrient rich conditions also experience basal UPR activity in presence of unfolded proteins in ER. *HAC1* mRNA splicing varies dynamically in response to nitrogen availability and presence of different carbon sources. The level of *HAC1* mRNA splicing is induced tenfold in non-fermentable carbon source compared to fermentable carbon sources. In addition, the basal UPR activity serves to aid protein folding in healthy cells (Schröder et al., 2000). The

repression of metabolic genes *ACS1* encoding acetyl coenzyme A synthetase, *CAR1* encoding arginase, and *INO1* in Ume6p and Rpd3 HDAC-dependent manner further highlights the role of UPR in healthy cells to its metabolic regulation (Schröder et al., 2004).

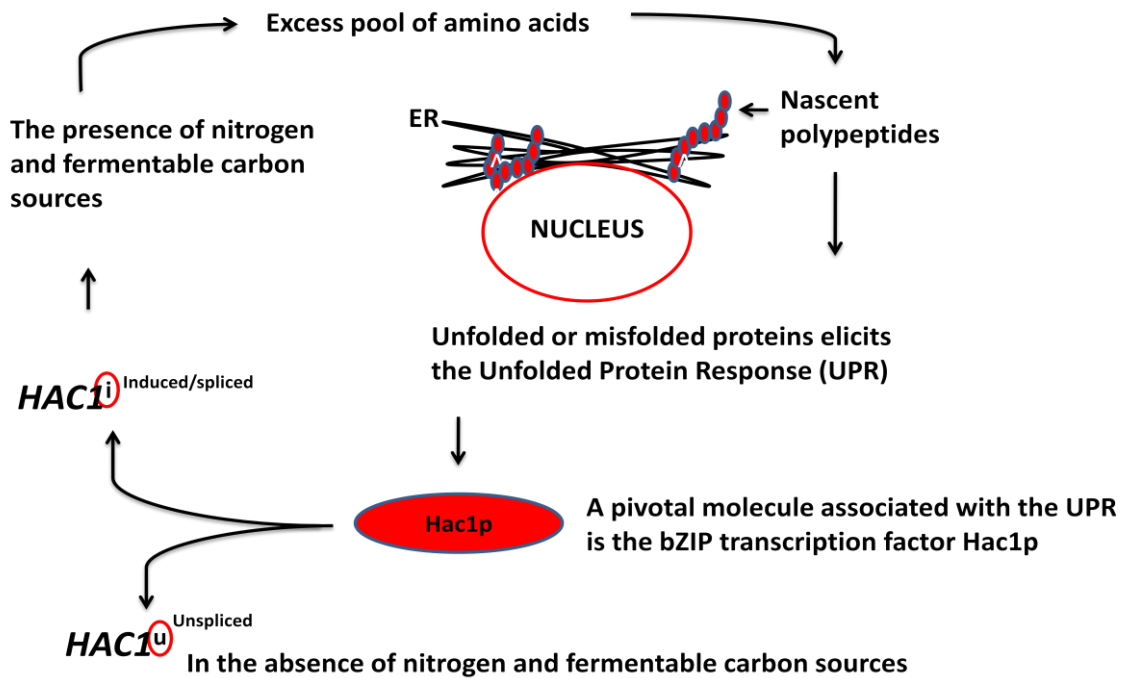

**Figure 1.11 ER stress and nitrogen availability is linked in yeast** A diagram showing the link between nitrogen requirements and eliciting the UPR response (from Schroder et al., 2000)

The role of the UPR in mammalian systems including the immune response, pancreatic cell development and plasma cell differentiation has been reported. *IRE1* mediated *XBP1* splicing is required to drive the differentiation and activation of UPR is needed to expand the ER and meet the demand of high secretory activity of B-cells (Calfon et al., 2002; Iwakoshi et al., 2003; Lee et al., 2005a; Reimold et al., 2001; Zhang et al., 2005). The role of *IRE1* mediated *XBP1* splicing is consistent with the requirement for *XBP1* in pancreatic acinar cell development (Lee et al., 2005) and during ER expansion through induction of phospholipid biosynthesis and membrane proliferation for plasma cell differentiation (Shaffer et al., 2004; Sriburi et al., 2004). Mammalian



Rpd3p orthologs bind to the *c-myc* promoter by Blimp-1 (Yu et al., 2000) for *c-myc* transcriptional repression (Lin et al., 2000) required by terminal differentiating B-cells. Hence there is evidence that the UPR signaling robustly is involved in maintaining differentiation in mammalian cells.

#### **1.2.4 A mechanism of transcriptional repression of *EMGs* by Rpd3 HDAC and bZIP Hac1p**

Hac1<sup>i</sup> represses transcriptional induction of a large class of genes controlled by the promoter element URS1, including the starvation-induced *EMGs* (Schröder et al., 2000; Schröder et al., 2004). URS1 (Upstream repressing sequence 1) can be found in promoters of meiosis-specific genes like *SPO13*, *HOP11* and *IME2* and non-meiotic genes like *CAR1* (Gailus-Durner et al., 1996). Synthesis of Hac1<sup>i</sup> in nutrient-rich conditions and rapid shut-off of Hac1<sup>i</sup> synthesis in nitrogen-starved cells suggest that Hac1<sup>i</sup> transduces a nitrogen signal to *EMG* promoters (Schröder et al., 2000). Overexpression of Hac1<sup>i</sup>p decreases activation of *EMGs* under nitrogen starvation, while deletion of *HAC1* increases mRNA levels of *EMGs* under nitrogen-rich conditions (Schröder et al., 2000). URS1 is the DNA binding site for the transcriptional regulator Ume6 (Unscheduled meiotic gene expression 6), a zinc cluster DNA binding protein. (Strich et al., 1994), which recruits the ISW2 chromatin remodeling complex (Goldmark et al., 2000) and the Rpd3-Sin3 HDAC (Schröder et al., 2004) to promoters of *EMGs*. Repression of *EMGs* by Hac1<sup>i</sup> required the HDAC activity of Rpd3 as shown in Figure 1.12 (Schröder et al., 2004). Deletion of *SDS3*, a subunit specific to one of two Rpd3 complexes in *S. cerevisiae*, the large Rpd3 complex (Rpd3L), abolished the effects of Hac1<sup>i</sup> on *EMG* expression, suggesting that Hac1<sup>i</sup> represses *EMGs* through the HDAC activity of the Rpd3 large complex (Schröder et al., 2004).

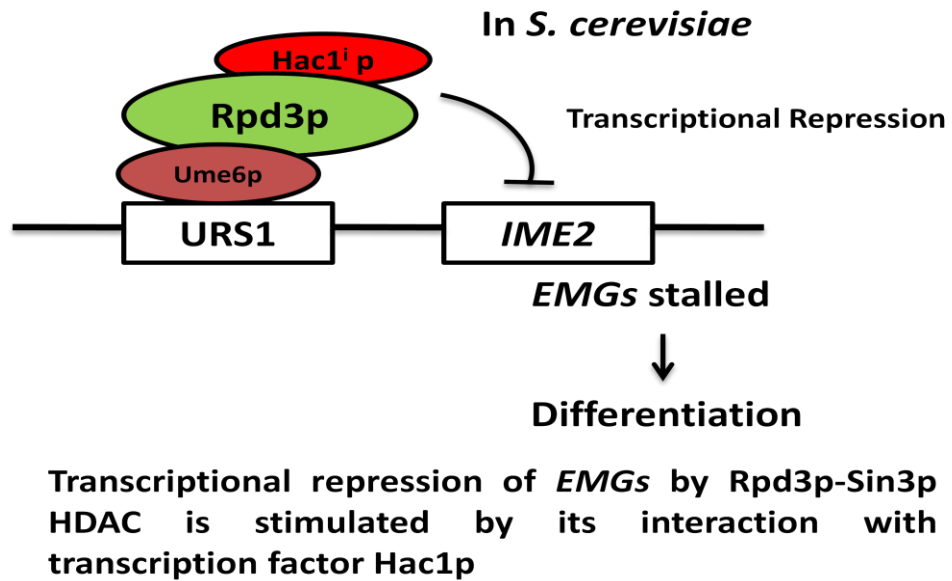

**Figure 1.12** A mechanism of regulating *EMGs* via Rpd3 and Hac1 in *S.cerevisiae* A diagram showing that Hac1 and Rpd3 interact together to repress *EMGs* (Schröder et al., 2004).

### 1.2.5 Rpd3 HDAC in ER stress and osmotic stress

Studies on ER stress response in *S. cerevisiae* (as shown in Figure 1.12) show that transcriptional regulation of *EMGs* involve important chromatin associated factors like the bZIP transcription factor Hac1p and the Rpd3p HDAC. Thus in general, transcription machinery and chromatin dynamics are intimately linked. Onset of transcription is based on interaction of molecules like RNA pol II, transcription factors, coactivators, corepressors and sequence specific DNA binding proteins associated with the chromatin (Roeder and Rutter, 1969; Matsui et al., 1980; Segall et al., 1980). In contrast to the role of Rpd3 in repressing *EMGs* (Schröder et al., 2004), it has been shown that Rpd3 can have activating functions as well. Osmotic stress was the first stress response where Rpd3 was shown to activate a subset of osmoresponsive genes (deNadal et al., 2004).

### 1.3 Stress response and transcriptional regulation in *S. cerevisiae*

Studies on ER stress by Schröder and colleagues (Schröder et al., 2004) investigating the role of Hac1p and Rpd3p is the point from which this study developed. Yeast cells gain cross protection against different stresses. Cellular perturbances during stress, if not dealt with immediately by the cell can affect the optimal enzymatic activities, disrupt cellular structures and disrupt metabolic fluxes resulting in an overall instability. Yeast cells have evolved to become extremely adaptable to sudden changes in their environment. Details regarding how yeasts coordinate gene regulation mechanisms for adapting to environmental challenges has been accumulating over years. There is evidence that yeast cells when exposed to a mild dose of one stress become resistant to large, normally lethal doses of other stresses (Mitchel and Morrison 1982; Blomberg et al. 1988; Flattery-O'Brien et al. 1993; Lewis et al. 1995). This observation provided the basis for the idea that yeast cells use a general mechanism of cellular protection that is provoked when cells are exposed to stressful stimuli. Subsequently it became apparent that the stress induced gene expression was controlled by a common mechanism. A number of studies identified a sequence element common to the promoters of the stress responsive genes known as the Stress Responsive Elements (STRE) (Kobayashi and McEntee 1990; Kobayashi and McEntee 1993; Marchler et al., 1993) which eventually were discovered as the the DNA binding site for the 'global' transcription factors Msn2 and Msn4 (Martínez-Pastor et al., 1996; Schmitt and McEntee, 1996). The activity of Msn2/4 is controlled by several major signaling pathways, such as protein kinase A (Smith et al., 1998) and Tor (Beck and Hall, 1999) signaling. It was also shown that under certain stress conditions the genes identified as targets of these two global transcription factors were normally induced regardless of their deletion indicating that regulation of stress response was not entirely dependent on these two factors (Schuller et al., 1994).

The recent increase in popularity of whole genome studies for transcription and protein analysis (gene expression microarray analysis and protein microarrays) in the past two decades has

provided a better understanding of yeast stress response. In the yeast *Saccharomyces cerevisiae* the general stress response (GSR) exists to protect cells from diverse stress conditions. This GSR consists of ~600 co-repressed and ~300 co-induced genes (Causton et al., 2001; Gasch et al., 2000). Of the co-induced genes, many function in detoxification of reactive oxygen species, cell wall strengthening, protein folding and degradation, DNA damage repair, control of osmolyte balance, and production of storage carbohydrates. A strong, global correlation between Msn2/4-dependent genes and genes whose expression is dependent on the mitogen-activated protein (MAP) kinase Hog1 (Capaldi et al., 2008; Rep et al., 2000) suggests extensive overlap between the GSR and the high osmolarity glycerol (HOG) MAP kinase pathway.

### **1.3.1 Osmosis and organisms adapting to water stress in a natural environment**

Water is essential for survival for all living organisms as it is critical for all cellular processes. Loss of water from cells due to evaporation, excretion of wastes or osmosis poses a threat for a cell. Osmosis is a phenomenon where a solvent moves from a system through a selective permeable membrane, to equilibrate solute concentrations on both sides. Osmosis may occur in an environment of excess saline, extracellular freezing or from diseases that cause osmotic imbalances like diabetes. Thus to prevent osmotic shrinkage, internal cellular fluids equilibrate the pressure exerted by an external hypertonic environment. The basic solutes found in most cells ( $K^+$ , metabolites, proteins etc) have an average osmotic concentration of 300-400 milliosmoles (mOsm) per litre. While the major osmotic components inside cells are usually organic osmolytes, the extra cellular fluids in multicellular organisms are dominated by NaCl (Yancey, 2004, 2005).

Organisms have been divided into two broad categories depending on their ability to adapt to water stress. Osmoconformers are mostly found in oceans and include most types of life forms other than most vertebrates and some arthropods. These organisms regulate their physiology by

having the same osmotic pressure as that of the external water environment of about 1000 mOsm. The internal osmolytes can be upregulated or downregulated in many species to prevent osmotic shrinkage or swelling if the osmotic concentration of the environment changes. Osmoregulators have regulatory organs (eg, gills or kidneys) which keep the internal body fluids at around 400 mOsm or less. This is also the pattern in terrestrial vertebrates (Yancey, 2005).

### **1.3.2 Osmotic stress, osmolytes and need for glycerol production in *S.cerevisiae***

Yeast cells in a hyperosmotic environment experience loss of water from its internal surrounding and shrink. This in turn results in an increase in concentration of biomolecules and ions resulting in an arrest of cellular activity. The osmotic properties of *S.cerevisiae* have been studied extensively as it is both a model organism and due to its use in industrial processes. The initial need to understand the molecular mechanisms in response to hyperosmotic shock was to produce robust strains for industrial processes (Pretorius, 2000; Randez-Gil et al., 1999). Studies intensified in this area with the discovery of a mitogen activated protein kinase (MAPK) cascade, a conserved eukaryotic signal transduction pathway that was found to be intrinsically linked to osmoregulation in yeasts (Brewster et al., 1993; Gustin et al., 1998). High molar concentrations of substances like sodium chloride (NaCl) and sorbitol have been used extensively as osmotic shock agents for *S. cerevisiae* (Hirasawa et al., 2006; Karlgren et al., 2005). NaCl stimulates osmotic responses in essentially the same way as sugars or sugar alcohols (Rep et al., 1999, 2000; Causton et al., 2001). The Na<sup>+</sup> ion is toxic however because it replaces the K<sup>+</sup> ions in biomolecules (Serrano, 1996; Serrano 1997). Thus the Na<sup>+</sup> stimulates additional detoxification pathways in response to hyperosmotic stress. Several mechanisms are involved in the adaptation to water stress by *S. cerevisiae*. Accumulation of glycerol is essential for salt tolerance since mutants that cannot accumulate glycerol are salt sensitive (Albertyn et al., 1994). The two most important functions of

glycerol synthesis in yeast are related to redox balancing and hyperosmotic stress response. One of the consequences of hyperosmotic stress is the rapid diffusion of water from the cell to the external surrounding. To prevent this many yeasts produce glycerol and many other polyols (Brown, 1976). Cells require glycerol production to maintain the redox balance as respiration is limited by glucose and oxygen deficiency (Lowry and Zitomer, 1984).

### **1.3.3 The MAP kinase pathway in *S.cerevisiae***

About 15% of yeast genes are activated when a cell is under hyperosmotic shock indicating the importance of gene regulation in the osmotic shock response (Causton et al., 2001; Gash et al., 2000; Posas et al., 2000; Rep et al., 2000; Yale and Bohnert., 2001; Martínez-Montañés et al., 2010; Miller et al., 2011). Exposing yeast to osmotic shock has been shown to affect different signalling pathways. Upregulation or downregulation of genes is controlled by signalling pathways which sense a shift in the osmotic balance and subsequently transmit a signal to the transcriptional machinery. The best characterised pathway to date is the HOG pathway which is activated within less than a minute of osmotic upshift (Brewster et al., 1993). The protein kinase A (cyclic AMP [cAMP]-dependent protein kinase) has been shown to affect expression of genes upon an osmotic upshift (Norbeck and Blomberg, 2000) but it is not well understood how the activity of Protein kinase A reacts to control osmotic stress. Protein kinase A mediates a general stress response that is observed under essentially all stress conditions, such as heat shock, nutrient starvation, high ethanol levels, oxidative stress, and osmotic stress (Marchler et al., 1993; Siderius and Mager, 1997; Ruts and Schüller, 1995). Hence it is expected that protein kinase A most probably does not respond directly to osmotic changes. The MAK kinase pathways are highly conserved signalling cascades occurring in all eukaryotes, where each molecule in the cascade plays an essential role in response to an environmental signals or hormones, growth factors or

cytokines. Many recent studies have shown that the MAPK pathway controls a number of cellular physiological parameters like growth, morphogenesis and proliferation (Saito, 2010; Fuchs and Mylonakis 2009; Hohmann, 2009).

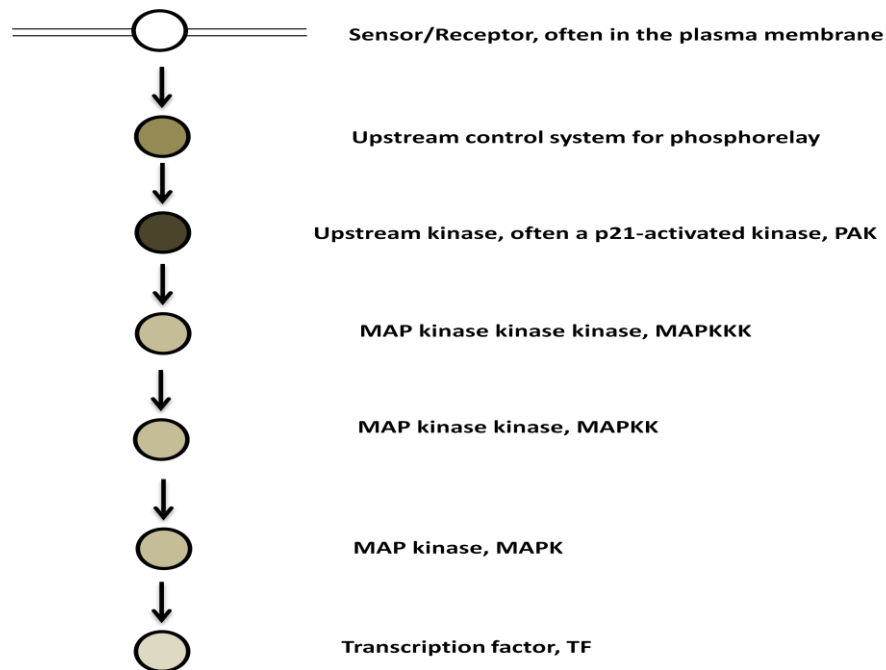

**Figure 1.13** A diagram showing the molecules involved in the MAPK cascade signalling. Arrows indicate the path of the cascade and the pathway specific proteins are similar in all eukaryotes and required for signal transmission (from Hohmann, 2002).

Different pathways within a eukaryote, including *S. cerevisiae* share kinases. Hence Figure 1.13 is an oversimplified view of MAP kinase signalling. MAP kinase pathways are negatively controlled by protein phosphatases (Keyse, 2000). Genetic analyses and transcriptional readout from physiological, pharmacological and genetic stimulation have revealed that there are five known MAP kinases in *S. cerevisiae* (Hohmann, 2002). These 5 MAP kinases belong to six distinct MAP kinase pathways as shown in Figure 1.14.

In *S. cerevisiae*, Sln1p and Sho1p have been described as sensors of the two upstream branches controlling the HOG MAP kinase pathway. The HOG pathway is activated by osmotic upshift (Brewster et al., 1993) and genetic evidence places Sho1p (Posas and Saito, 1997) and Sln1p (Maeda et al., 1994) upstream of all other HOG pathway components. Moreover, mutations in *SHO1* (Posas and Saito, 1997) and *SLN1* (Maeda et al., 1994) affect the activity of the HOG pathway, and both Sho1p and Sln1p have been shown to be located in the plasma membrane (Reiser et al., 2000; Ostrander and Gorman, 1999)

A two-component system in *Saccharomyces cerevisiae* regulates an osmosensing MAP kinase cascade. The signal is transferred by the Hog1 (High osmolarity glycerol 1) and, among many other effects, potentiates expression of the glycerol biosynthetic pathway (Maeda et al., 1994). The production of glycerol requires the precursor Glycerol-3-Phosphate dehydrogenase (GPD), which is encoded by two genes, *GPD1* and *GPD2*. The level of glycerol and the expression of *GPD1* and *GPD2* are partially controlled by the *HOG1* signal transduction pathway when yeast is exposed to hyperosmotic shock (Albertyn et al., 1994). As in other yeasts, active glycerol uptake from the environment has been observed (Lages et al., 1999) but does not normally contribute to osmoadaptation in *S. cerevisiae* (Holst et al., 2000). Rather, intracellular glycerol levels are controlled by passive glycerol export, which is mediated by Fps1 (Hohmann, 2002; Luyten et al., 1995; Tamás et al., 1999; Oliveira et al., 2003). In combination with a *SLT2/MPK1* double deletion strain, which causes sensitivity to hypo-osmotic shock due to a weaker cell wall, the *FPS1* deletion causes lethality and visible cell bursting (Philips and Herskowitz, 1997; Tamas et al., 1999). Upon a hyperosmotic shock the transport capacity of Fps1 is sequestered to ensure that glycerol is maintained inside the cell (Hohmann, 2002; Luyten et al., 1995).



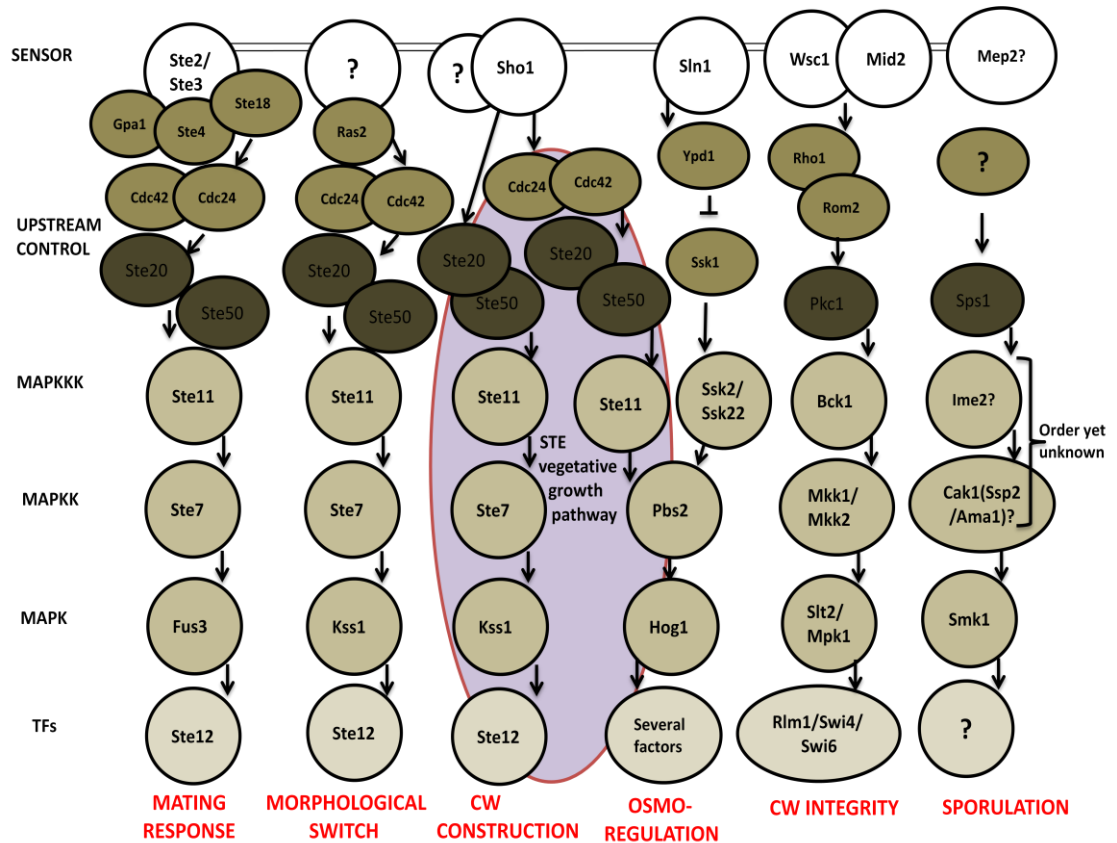

**Figure 1.14 A sketch of the yeast MAPK pathways (modified from Hohmann, 2002)** Sho1p together with Ste20p, Ste11p, Ste7p, Kss1p, and Ste12p appears to form an independent MAP kinase pathway, the *STE* vegetative growth pathway, which seems to be part of the systems that control cell wall integrity (Cullen et al., 2000; Lee et al., 1999). The *STE* vegetative growth pathway is required for growth at normal osmolarity.

Pbs2p is activated by phosphorylation of Ser514 and Thr518 by Ssk2p, Ssk22p or Ste11p. Pbs2p is a cytoplasmic protein and appears to be excluded from the nucleus (Ferrigno et al., 1998; Reiser et al., 1999). Thus phosphorylation of Hog1, the substrate of Pbs2 occurs in the cytosol. Phosphorylated Hog1-GFP appears to be concentrated in the nucleus within a minute of osmotic shock while under normal conditions appears to be evenly distributed in the nucleus and the cytoplasm (Ferrigno et al., 1998; Reiser et al., 1999). This effect is specific because a range of other stress conditions does not cause Hog1 phosphorylation (Schüller et al., 1994; Ferrigno et al., 1998; Reiser et al., 1999). Phosphorylation on both Thr174 and Tyr176 of Hog1p by Pbs2p is

necessary and sufficient for nuclear concentration, since mutation of one or both of these sites makes the subcellular localization of Hog1p unresponsive to osmotic shock (Ferrigno et al., 1998; Reiser et al., 1999). The catalytic activity of Hog1p, however, is not required for transfer to the nucleus, since a catalytically inactive mutant of Hog1p is transferred to the nucleus very much like wild-type Hog1p (Ferrigno et al., 1998; Reiser et al., 1999).

### 1.3.3.1 Mechanism of Hog1 activation

The HOG pathway is controlled by a phosphorelay switch comprised of the cell surface sensor kinase (Sln1), a histidine phosphotransfer protein (Ypd1), and two response regulators (Skn7 and Ssk1) (Ketela et al., 1998; Li et al., 1998; Maeda et al., 1994; Ota and Varshavsky, 1993; Posas et al., 1998; Posas et al., 1996). The Skn7 protein is one of only two yeast proteins related to bacterial response regulators of so-called two-component signal transduction pathways (Li et al., 1998). Like many bacterial response regulators, Skn7 is a transcription factor. The other yeast response regulator, Ssk1, activates the MAP kinase cascade of the HOG pathway. Whereas Ssk1 appears to be entirely under the control of Sln1, the lone sensor kinase of yeast, Skn7 activity is only partially regulated by Sln1 (Li et al., 1998).

Changes in osmolarity are detected by two distinct putative osmosensors in the plasma membrane, Sln1p (Synthetic lethal of N-end rule 1) and Sho1p (Synthetic high osmolarity sensitive 1). Sln1 is a sensor of turgor pressure which is inactivated under conditions of low turgor or high osmolarity (Reiser et al., 2003). Under high-osmolarity conditions, inactive Sln1 accumulates, resulting in dephospho-Ssk1, which is the active form of this response regulator. The unphosphorylated Ssk1 activates the MAPKKKs Ssk2 and Ssk22 (Hohmann et al., 2007) which in turn activates the next MAPKK Pbs2 eventually leading to the phosphorylation and activation of Hog1. The alternative MAP kinase pathway, the Sho1 dependent pathway also eventually leads to

the activation of Hog1. The Sho1 dependent pathway does not appear to be conserved in all other fungi (Bahn, 2008). Thus, high extracellular osmolarity stimulates the Hog1 MAP kinase, which mediates, among other pathways, the biosynthesis and retention of glycerol as a compatible intracellular solute (Albertyn et al., 1994; Luyten et al., 1995; Thevelein and Hohmann, 1999). Under conditions of low osmolarity, Sln1p is active, causing autophosphorylation of a histidine residue, H576. This phosphate group is transferred to an aspartate residue, Asp1144 in the receiver domains of Sln1p and the signal transducers, Ypd1, Ssk1p and Skn7. Both Ssk1 and Skn7, constitute two branches of the same pathway as shown in Figure 1.15. Once Ssk1 is phosphorylated, it is inactivated resulting in the absence of *HOG1* pathway stimulation (Maeda et al., 1994). By contrast with Ssk1, dephospho-Skn7 is inactive. Thus in response to hypo-osmotic stress (high turgor pressure), Sln1 activity inhibits Ssk1 and stimulates Skn7 by phosphorylation at Asp427. Thus, depending on the direction of the change in osmotic conditions, one or the other branch of the HOG pathway is activated. Hypo-osmotic activation of Skn7 results in the transcriptional activation of at least one gene, *OCH1* (Lee et al., 2002), which encodes a mannosyltransferase involved in maturation of N-glycoproteins, many of which are destined for the cell wall and hence cell wall strengthening.

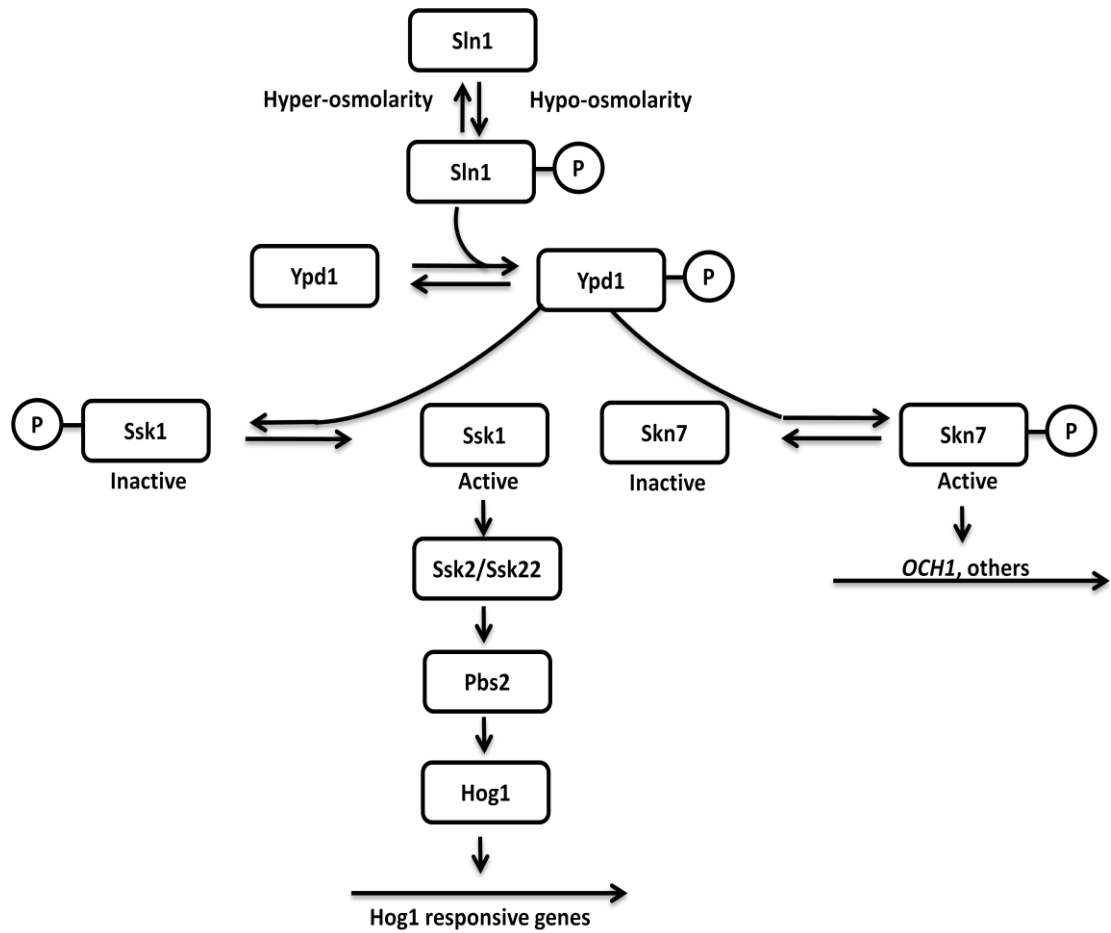

**Figure 1.15 The Sln1 branch of the Hog1 pathway** The phosphorelay mechanism of Hog1 activation depends on the Sln branch of MAP kinase pathway operating under hypoosmotic stress.

### 1.3.3.2 Transcriptional regulators of HOG pathway

There are very few known genes whose stimulation under hyperosmotic stress is regulated by Hog1. Transcriptional regulators have now been identified by global gene expression analyses (Gash et al., 2000; Posas et al., 2000; Rep et al., 2000). Some of the well known transcriptional regulators are listed in Table 1.4

	<b>Protein</b>	<b>Family</b>	<b>Function</b>	<b>Role</b>	<b>Reference</b>
1.	Sko1/ Acr1p	bZIP/ CREB	Repressor; also needed for activation from CREs	Hog1p target in vitro and in vivo; genetic evidence, promoter association	Proft and Serrano, 1999
2.	Msn2p/ Msn4p	Zinc finger	Activator; binds to STREs (CCCCT) and mediates protein kinase A dependent gene expression	Target genes depend on Hog1p under osmotic stress; STRE dependent reporter depends on Msn2p/Msn4p and HOG pathway	Rep et al., 2000; Schüller et al., 1994
3.	Hot1	Novel Helix-loop-helix	Activator; present together with Hog1p on some target promoters; for normal expression of some genes	Interaction with Hog1p, Hog1p dependent phosphorylation, promoter association	Alepuz et al., 2001; Rep et al., 1999
4.	Smp1	MADS box	Activator	Hog1p target	deNadal et al., 2003
5.	Msn1	Novel Helix-loop-helix	Activator; also involved in pseudohyphal growth and many more processes	Required for full expression of some Hog1p targets	Rep et al., 1999
6.	Sgd1	Zinc finger	Putative activator	Overexpression suppresses <i>hog1Δ</i> and <i>pbs2Δ</i> osmosensitivity	Akhtar et al., 2000
7.	Gcn4p	bZIP	Activator; required for stimulated expression of genes under general amino acid control	Required for Hog1p-dependent activation of <i>HAL1</i> expression from CRE	Pascual-Ahuir et al., 2001
8.	Skn7p	Heat shock factor	Activator; involved in numerous cellular processes, such as oxidative stress and cell wall metabolism	Part of Sln1p-Ypd1p phosphorelay, activates hypoosmotic genes	Brown et al., 1994

**Table 1.4 List of known TFs associated with Hog1 (From Hohmann, 2002).**

Global gene expression analysis reveal that the expression pattern of approximately 10% of yeast genes are jointly altered by several seemingly unrelated stress conditions, such as nutrient

starvation, oxidative stress, heat shock, and hyperosmotic shock. The exact gene number lies between 216 and 300 induced genes and 283 and 600 repressed genes (Gash et al., 2000; Causton et al., 2001). The general stress responses studied have been termed environmental stress response (Gash et al., 2000) and common environmental response (Causton et al., 2001). The induced genes are activated either by a general stress response factors like Msn2/Msn4 or promoter specific transcription factors, each of which regulates a small subset of genes either under hyperosmotic shock or a combination of stress responses. A large number of general stress-responsive genes are controlled by the stress response elements (STREs) via the transcriptional regulators Msn2p and Msn4p (Martinez-Pastor et al., 1996; Schmitt and McEntee, 1996). Bioinformatic studies have revealed that STREs have been found by in many gene promoters in yeast (Moskvina et al., 1998; Treger et al., 1998), and about 150 genes show altered expression in a mutant lacking both *MSN2* and *MSN4* (Gash et al., 2000, Causton et al., 2001; Rep et al., 2000). It was also observed that not all genes whose expression under stress is strongly affected in a *MSN2/MSN4* double deletion mutant strain contain an obvious STRE in their promoter. Hence, Msn2p and Msn4p might control many genes indirectly. Most genes that have been demonstrated to be directly controlled by Msn2p and Msn4p contain several STREs in close proximity (Moskvina et al., 1998). Hence it is likely that the two factors may be able to bind to different promoter elements, perhaps in conjunction with other factors.

The controlled expression of individual genes in response to a specific stress depends on promoter specific activation. For instance, a number of genes whose expression is induced by osmotic shock and oxidative stress are controlled by Sko1/Acr1p via the HOG pathway and by Yap1p, which specifically mediates oxidative stress responses (Jamleson, 1998). Sko1/Acr1p and Yap1p control target promoters via distinct promoter elements (Rep et al., 2001). Certain heat shock protein genes are induced by heat shock through the activity of the heat shock transcription factor and require Skn7p for induction by oxidative stress; both factors appear to operate via the

same promoter site, the heat shock element (Raitt et al., 2000). Another example is genes apparently induced by osmotic stress and nutrient starvation; the *HAL1* expression appears to be controlled by Hog1p-Sko1/Acr1p and Gcn4p through the same promoter site, a CRE (Pascual-Ahuir et al., 2001).

### 1.3.4 Cell wall integrity (CWI) pathway

The CWI pathway or the protein kinase C pathway orchestrates morphological changes in the cell by both controlling expression of genes encoding enzymes involved in cell wall metabolism and by reorganising the active cytoskeleton (Jung et al., 1999; Gustin et al., 1998; Heinisch et al., 1999). The CWI pathway is not a unidirectional pathway but like many other pathways is a network of interacting signalling routes that either diverge or converge from the Protein kinase C (Pkc1p) and the Rho1p G protein. The Pkc1p and the Rho1p are two central components of the CWI pathway and interact with other molecules from the Slt2/Mpk1 MAP kinase cascade (Lee et al., 1993), the calcineurin pathway (Garrett-Engle et al., 1995), the TOR pathway (Schmidt et al., 1997), the HOG pathway (Helliwell et al., 1998; Davenport et al., 1999), a phosphatidylinositol pathway (Yoshida et al., 1994), Cdc28p-dependent control of the cell cycle (Gray et al., 1997; Marini et al., 1996; Zarzov et al., 1996), and probably other additional pathways (Ragni et al., 2011; Heinisch et al., 1999; Harrison et al., 2001; Posas et al., 1993; Nikas et al., 1996).

#### 1.3.4.1 Mechanism of CWI activation

In *S. cerevisiae*, the CWI cascade is initiated by the CW sensors Mid2 (Mating pheromone induced death 2) and Wsc1 (Hcs77 or Slg1 –synthetic lethal with gap 1) (Verna et al., 1997; Ketela et al., 1999). These proteins bind to Rom2 (Rho1 multicopy suppressor1), which is a guanyl nucleotide

exchange factor for Rho1 (Ras homologue 1) (Ozaki et al., 1996; Philip and Levin, 2001). Rho1 binds and activated Pkc1 (Kamada et al., 1996; Nonaka et al, 1995) which in turn regulates the MAPK pathway. Pkc1 phosphorylates Bck1 (Bypass of C Kinase 1) a MAPK kinase kinase (MAPKKK) which then relays the signal to MAP kinases Mkk1 (Mitogen activated protein kinase kinase 1) and Mkk2 (MAPKKs). These two kinases eventually activate the MAPKs Slt2 (Supressor at low temperature 2) and Mpk1 (MAP kinase 1) (Banuett, 1998). Slt2 and Mpk1 then phosphorylated the transcription factors Rlm1 (Resistance to lethality of MKK1P386 overexpression 1) and SBF (Swi4 and Swi6) to activate genes involved in cell wall biogenesis (Dodou and Treisman, 1997; Jung et al., 2002; Watanabe et al., 1995; Madden et al., 1997).

#### **1.3.4.2 Crosstalk between the CWI pathway and the osmotic pathway**

The maintenance of cell integrity by the CWI pathway is similar within fungal species. The activation of the pathway is not restricted to a single stimulus and can be attributed to more than one stress response. A genome analysis of five cell wall mutants resulted in the transcriptional regulation of 5% of the yeast genes, many of which belonged to other stress signalling pathways (Lagorce et al., 2003). This suggests that the CWI pathway does integrate with other pathways in regulating cellular homeostasis under a stress or multiple stress environments. In *S. cerevisiae*, it has been shown that changes in an external osmotic environment elicit responses from both the CWI pathway and the Hog1 mediated MAP kinase pathway as indicated in Figure 1.16. In addition, the two pathways have been linked under CW stress (García et al., 2009; Reinoso-Martín et al., 2003). Furthermore, under hypoosmotic stress, the CWI pathway is activated which involves the MAP kinase Slt2/Mpk1 (Figure 1.16). The phosphorylation of Slt2/Mpk1 occurs without specificity toward osmotic solutes and is observed with hypotonic solutions of sorbitol, NaCl or glucose (Davenport et al., 1995). Cross talk thus occurs between the CWI pathway and the Hog1 pathway



involving Slt2/Mpk1. While hypotonic solution results in the phosphorylation of the Slt2/Mpk1 via a PKC pathway- dependent manner, hyperosmotic stress induce transcription of *SLT2/MPK1* in a Hog1 and Rlm-dependent manner (Hahn and Thiele, 2002). The CWI pathway properties are thus consistent with the fact that it controls cell wall metabolism during growth and development and protects cells upon stress leading to cell expansion or shrinkage, or cell wall damage. The CWI pathway and Hog1 MAPK pathway tend to collaborate in protecting and preserving the cell wall and the cell membrane (Hohmann, 2002).

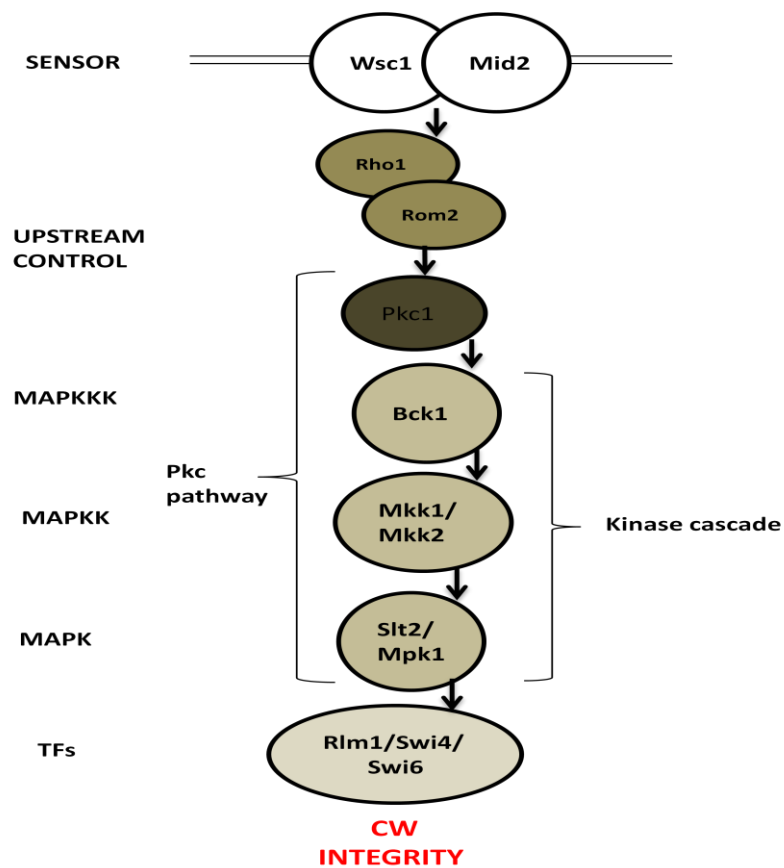

**Figure 1.16 A sketch of the CWI pathway** The CWI pathway has molecules which are common to

### 1.3.5 Osmotic stress and nutritional adjustment in *S.cerevisiae*

Osmotic stress demands metabolic adjustments in several different ways. Osmotic stress strongly reduces the uptake of several amino acids (Norbeck and Blomberg, 1998; Pascual-Ahuir et al., 2001). The availability of nutrients determines cellular functions like cell cycle progression, cell growth or a morphological switch. Nutrient stress occurs when cells are shifted from a nutrient rich to a nutrient depleted media. A shift could be an external environment like soil or *in vitro*. Nutrient deprivation itself is stressful and stimulates a general stress response (Gash et al., 2001; Causton et al., 2000). Adjustment of cellular metabolism at the transcriptional and posttranscriptional level in response to the availability of carbon sources or the quality of carbon is controlled by the Snf3/Rgt2 sugar-sensing pathway (Boles and Hollenberg, 1997), the Gpr1-cAMP-protein kinase A pathway (Lengeler et al., 2000; Thevelein and Winde, 1999), the Snf1 pathway (Carlson, 1999; Gancedo, 1998), and the TOR pathway (Rohde et al., 2001; , Schmelzle and Hall, 2000). Availability and quality of nitrogen sources and amino acids are monitored by the Ssy1 sensing system (Forsberg and Ljungdahl, 2001), the Gcn4p transcriptional regulator (Hinnebusch, 1997), a pathway that involves the ammonium sensor Mep2p's mediating nitrogen catabolite repression (Lengeler et al., 2000), and again the TOR pathway (Rohde et al., 2001; , Schmelzle and Hall, 2000). In *S. cerevisiae*, the TOR (Target of Rapamycin) signalling pathway has been well studied under different nutritional conditions. There are two genes involved, *TOR1* and *TOR2*. There is evidence for cross-talk between the CWI pathway and TOR signalling (Torres et al., 2002). The TOR signalling and CWI pathways share a common role in actin assembly and organisation, however only *TOR2* is known to participate in the actin assembly process (Schmidt et al., 1996).

### **1.3.6 Links and signal integration events occur between different stress response pathways**

Different stress response pathways can often share common transducers. For example, crosstalk occurs between the CWI pathway and the osmotic stress pathway as described previously. In the following part of the introduction, from the literature there is strong evidence that stress pathways are linked via common interacting molecules. Some of these stress pathways have a characterised mechanism of signal integration, while in others a mechanism is yet to be identified. In the next section, the link between ER stress and other stress signalling pathways will be introduced.

#### **1.3.6.1 ER stress and cell wall stress**

In *S. cerevisiae*, cell wall defects (Scrimale et al., 2008) and hypoosmotic stress (Pal et al., 2007) activate the UPR, while mutants defective in the cell wall integrity and Hog1 MAP kinase signaling pathways are sensitive to ER stress (Chen et al., 2005; Torres-Quiroz et al., 2010) and activate the UPR (Bicknell et al., 2010). Rpd3 HDAC is shown to have opposite roles in regulating genes during ER stress and osmotic stress (Schröder et al., 2004; deNadal et al., 2004) but other histone deacetylases, like the Hos2/Set3 HDAC integrate into ER stress signalling via the Mpk1p cell wall integrity pathway (Cohen et al., 2008). Putative cell wall stress sensors WscA and WscB are involved in hypo-osmotic and acidic pH stress tolerance in fungi, *Aspergillus nidulans* (Futagamy et al., 2011). ER stress activates Hog1 (Bicknell et al., 2010) and SlT2 (Babour et al., 2010; Bonilla and Cunningham, 2003), the MAP kinase of the cell wall integrity signaling pathway. Interestingly in one study, 20 plasma membrane proteins, including the P-type H<sup>+</sup>-ATPase Pma1, ABC

transporters, glucose and amino-acid transporters, t-SNAREs, and proteins involved in cell wall biogenesis showed a significant and rapid decrease in abundance in response to both 0.4 M and 1 M NaCl. It was proposed that rapid protein internalization occurs as a response to hyper-osmotic and/or ionic shock, which might affect plasma membrane morphology and ionic homeostasis. It was also suggested that this rapid response might help the cell to survive until the transcriptional response takes place (Szopinska et al., 2011).

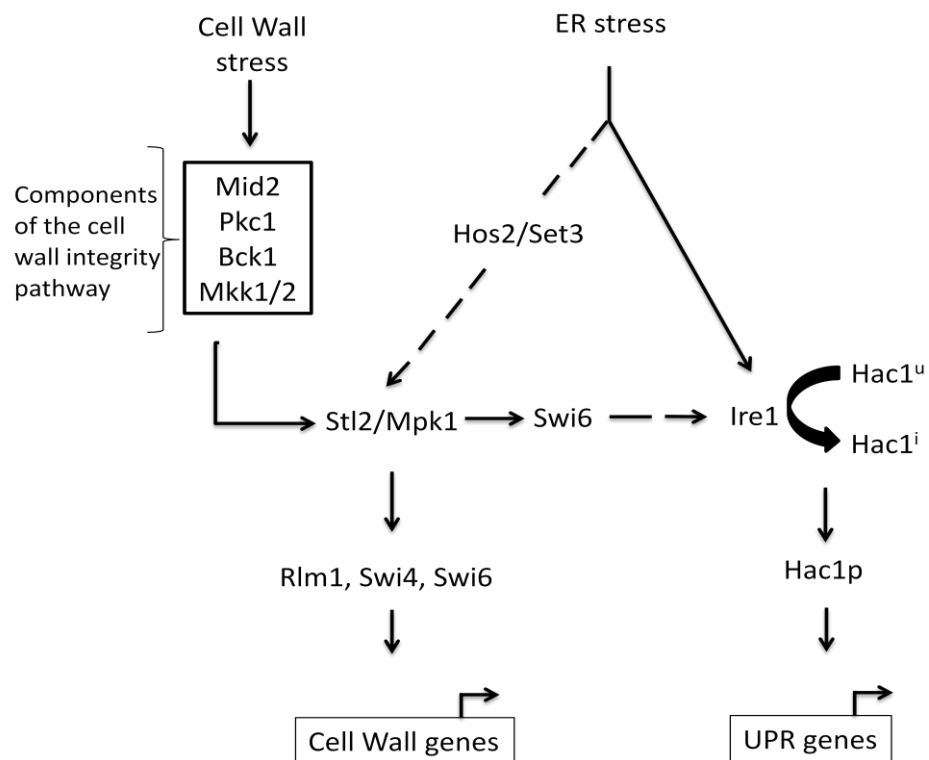

**Figure 1.17 A link between ER stress and CW stress** There is a link between the ER and cell wall stress response in *S. cerevisiae* (Krysan, 2009)

### 1.3.6.2 ER stress and heat shock stress

The ER stress component Rpd3 HDAC and the SAGA complex have been shown to dynamically regulate the heat shock gene structure and function (Kremer and Gross, 2009). It has also been

shown that heat shock relieves ER stress by affecting multiple ER activities (Liu and Chang, 2008). Genome analysis reveals that greater than 25% of the genes have function in common with the UPR targets. Using a constitutively active Hsf1 transcription factor to induce HSR without temperature shift, it was shown that HSR rescues growth of stressed *ire1Δ* cells, and partially relieves defects in translocation and ERAD. HSR is activated by ER stress *in vivo*, but to a lower level than that caused by heat (Liu and Chang, 2008).

### 1.3.6.3 ER stress and osmotic stress

Hog1 is a MAPK intrinsically linked to the osmotic stress pathway and Hac1p and Rpd3p are critical within the ER stress pathway. Interactions between ER and osmotic stress responses have been reported in all eukaryotes. For example, salt stress in *Arabidopsis thaliana* activates an ER stress-like response (Liu et al., 2007). A genome-wide RNAi screen in *Caenorhabditis elegans* found that the majority of genes whose inactivation caused constitutive expression of an osmosensitive reporter, were involved in the regulation of protein translation, cotranslational protein folding or the targeting and degradation of damaged proteins (Lamitina et al., 2006), suggesting that unfolded proteins trigger expression of genes protecting against osmotic stress. Stimulation of glycerol production by Hog1 contributes to survival of ER stress (Torres-Quiroz et al., 2010). During hyperosmotic Hog1 contributes to glycerol synthesis which is involved in maintaining the redox potentials within the mitochondria. Hence a signalling event between ER and the mitochondria is also likely during hyperosmotic stress. As is the case, the mitochondrial antioxidant function has been shown to be an inducible determinant of osmotic stress adaptation in yeast. The osmosensitivity of mitochondrial mutants was not caused by impaired stress-activated transcription or by a general depletion of the cellular ATP pool during osmotic stress. The growth defect of mitochondrial mutants in high salt medium could be partially rescued by

supplementation of glutathione. Additionally, mitochondrial defects caused the hyper-accumulation of reactive oxygen species during salt stress. These data suggest that the antioxidant protective properties in mitochondria possibly provide resistance against hyperosmotic stress (Pastor et al., 2009). Again, Copper or Zinc oxide dismutase, important enzymes in antioxidant defense and NADP (H) homeostasis, both critical to mitochondria have been shown to be required for ER stress tolerance in yeast (Tan et al., 2009).

#### **1.3.6.4 ER and osmotic stress related bZIP transcription factors in plants**

While the UPR response is well documented in plants, less is known about the components within the signalling pathway. Plants possess at least two signaling pathways specific for UPR. ER membrane-bound ER stress sensor/transducers, AtbZIP60 and AtbZIP28, are basic leucine zipper transcription factors that are activated by regulated intramembrane proteolysis systems and regulate transcription of the UPR genes. It has been shown recently that *A. thaliana* bZIP transcription factor AtbZIP60 modulates the ER stress response by activating a sub-group of protein disulphide isomerase genes (Lu and Christopher, 2008). These signaling pathways play important roles not only in the UPR but also have been shown to play a role in biological processes such as the response to pathogens and heat stress (Urade, 2009). Furthermore, overexpression of AtbZIP60 produces plants with a higher tolerance for salt stress, suggesting that this transcription factor may play a role in abiotic stress. Hence cross-talk between genes involved in the UPR and abiotic stress appears likely (Moreno and Orellana, 2011). In soybean plants, a novel transcription factor, ERD15 (Early Responsive to Dehydration 15) has been discovered that connects ER stress with an osmotic stress-induced cell death signal (Alves et al., 2011). The ERAD pathway has been shown to be critical for plant survival to high salt stress (Liu et al., 2011).

### 1.3.6.5 Links between bZIP transcription factors and osmotic stress in plants and mammals

Hac1p is a bZIP transcription factor involved in the UPR in yeast. Recent reports suggest that a number of bZIP transcription factors (TFs) in plants and higher mammals protect against osmotic and salt stress. The *Arabidopsis thaliana* AtbZIP1 transcription factor is a positive regulator of plant tolerance to salt, osmotic and drought stresses (Sun et al., 2011). bZIP transcription factor ZmbZIP72 confers drought and salt tolerance in transgenic *Arabidopsis* plants (Ying et al., 2011) while the bZIP TF AP2/ERF RAP2.6 participates in ABA, salt and osmotic stress responses (Zhu et al., 2010). A *ThZFL* zinc-finger-like gene is induced under salt, osmotic stress and ABA treatment and over-expression of this gene confers osmotic and salt resistance in *S cerevisiae* and tobacco (An et al., 2011).

Evidence is mounting which supports the idea that there are links between various stress pathways. Mechanisms of signal integration between stress pathways such as osmotic stress and cell wall stress, and cell wall stress and ER stress have been discussed. A signal integration event linking osmotic stress and ER stress yet remains unidentified, this despite the fact that key regulatory molecules linking both pathways have been identified. Investigating a possible link between the ER stress pathway and osmotic stress is the aim of this work.

## 1.4 Aims and objectives

Hac1p and Rpd3p have been shown to be important molecules in nutrient signalling in yeast (Schröder et al., 2000). These two molecules play a critical role in ER stress by repressing *EMGs* (Schröder et al., 2004). Recent reports suggest that the Rpd3 HDAC, known to repress genes and acting as a global repressor in yeast (Kurdistani et al., 2002) provides activating functions to a number of genes (Bumgarner et al., 2009; Sertil et al., 2007; Sharma et al., 2007; Xin et al., 2007), including several genes of the GSR (Alejandro-Osorio et al., 2009; de Nadal et al., 2004). Rpd3p-dependent transcriptional repression by Hac1<sup>i</sup> and Rpd3 being a positive regulator of GSR gene activation suggests that:

- Hac1p has a protective role in hyperosmotic stress
- Hac1p acts via Rpd3p and is a positive regulator of GSR gene expression
- Hac1p affects nucleosome histone acetylation levels in regulating GSR genes

Therefore the aim of this PhD thesis is to investigate whether there is a crosstalk between the ER signalling pathway and osmotic stress.

The objectives of this thesis can be summarised as follows:

- Hac1p and Rpd3p are critical components of the ER pathway and have been shown to act together during ER stress (Schröder et al., 2004). ER specific components like *IRE1*, *HAC1* and *RPD3* will be examined for their protective role during hyperosmotic stress (Chapter 3).
- Hac1<sup>i</sup> splicing is an important phenomenon during ER stress. Whether or not Hac1<sup>i</sup> splicing occurs during osmotic stress will be demonstrated (Chapter 3).



- Hac1p and Rpd3p act together in the same pathway to repress *EMGs* (Schröder et al., 2004). Whether Hac1p acts via Rpd3p in the osmotic stress pathway to regulate GSR gene expression will be investigated (Chapter 4).

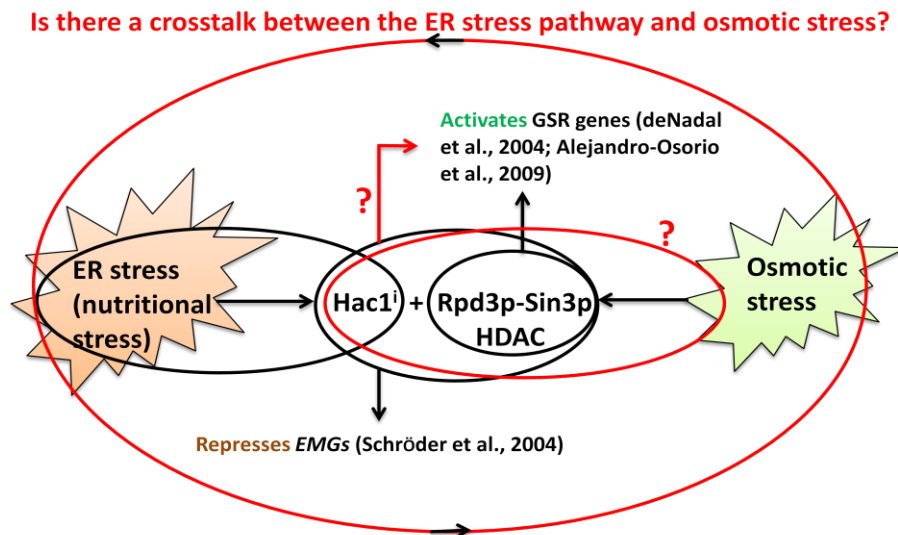

**Figure 1.18 Summary of the aim and objectives** The aim of my PhD work is to determine if there is crosstalk between the ER stress signalling and osmotic stress. The black ovals and arrows represent known concepts in the two pathways. The red ovals and arrows are some questions which will be addressed in this thesis. Hac1p and Rpd3p are well characterised molecules during ER stress and act in the same pathway to repress *EMGs* (Schröder et al., 2004). The aim is to determine whether Hac1p and Rpd3p are required for the osmotic stress response or not, and whether they act together in the same pathway to activate and epigenetically regulate GSR gene expression.

If it is demonstrated that Hac1p and Rpd3p are required for the osmotic stress response and together they regulate the GSR genes, then the following questions will be addressed:

- How does Hac1p regulate GSR gene expression (Chapter 4)?
- Does Hac1p directly regulate GSR genes (Chapter 4)?

- Are the GSR genes regulated epigenetically (Chapter 4 and Chapter 5)?
- What is the mechanism by which Hac1<sup>i</sup> and Rpd3 potentiate expression of GSR genes (Chapter 6)?

## CHAPTER 2

---

# MATERIAL AND METHODS

## 2.1 Chemicals, reagents and commercial kits

The table below lists the chemicals, reagents and commercial kits used in this study.

**Table 2.1 List of chemicals, reagents and commercial kits used in this study**

<b>Name of Chemical</b>	<b>Company and Catalogue number (Cat.No)</b>
Acetic acid	Fisher Scientific, # A/0360/PBH
Agarose molecular grade	Bioline, # BIO-41025
Clelands reagent	Calbiochem, # 233155
Diethyl pyrocarbonate (DEPC)	Sigma, # D5758
Dimethyl sulfoxide (DMSO)	Sigma-Aldrich, # D5879
Disodium hydrogen orthophosphate dodecahydrate	Fisher Scientific, # 10039-32-4
Disodium hydrogen orthophosphate	Sigma-Aldrich, # S3264-250G
2 mM dNTPs	Fermentas Life Sciences, # R0181
Ethanol (Et-OH)	Fisher Scientific , # E/0500/17
Ethylenediamine tetraacetic acid (EDTA)	Fisher Scientific, # BPE119-500
Ficoll 400	Fluka, # 46327
Formaldehyde (37% w/v stock solution)	Fisher Bioreagents, # BP531-500
Gene Ruler™ 1Kb DNA ladder	Fermentas Life Sciences, # SM0311
D -Glucose	Fisher Scientific, # 50-99-7
Glycerol	Fisher Scientific, # 56-81-5

Glycine	Fisher Bioreagents, # BP 381-1
HEPES	Fisher Bioreagents, # BP 310-100
Hydrochloric acid	Fisher Scientific , # H/1100/PB17
Isoamyl alcohol	BDH, # 272124U
Lithium acetate (LiOAc)	Fisher Scientific , # L/2050/50
Lithium Chloride (LiCl)	
Magnesium chloride (MgCl <sub>2</sub> )	BDH, # 2909647
Phenol:CHCl <sub>3</sub> :isoamylalcohol 25:24:1;v/v/v)	Fisher Scientific, # BPE1752P-400
Polyethylene glycol 4000	Sigma-Aldrich, # P 3640
Potassium acetate	Fisher Scientific, # P3760153
Potassium chloride	Fisher Scientific, # P/4240/53
Potassium dihydrogen phosphate	Fisher Scientific, # 7778-77-0
Potassium phthalate monobasic	Sigma-Aldrich, # P6758 -500 G
Protease inhibitor cocktail • Complete • Mini	Roche Applied Science, # 11836153001 # 11836153001
Proteinase K Protein A Agarose beads	VWR International, # 390973P Santa Cruz Biotechnology
Sheared salmon sperm DNA (8.31 mg/ml or 6.89 mg/ml)	Sigma, # D-1626
Sodium chloride	Fisher Scientific, # 7647-14-5
Sodium deoxycholate	Sigma, # D6750

Sodium dodecyl sulfate (SDS)	Promega, # H5114
Sodium hydroxide (NaOH)	Anal-R Normapur, # 28244.262
Sorbitol	Sigma, # S0900
SybrGreen stock solution (10000X stock solution)	Invitrogen, Paisley, UK, # S7563
Tris (hydroxymethyl) methylamine	Fisher Scientific, # T/3710/60
Triton-X 100	Fisher Scientific, # T/3751/08
Tween 20	Fisher Scientific, # BPE 337-500
Wizard SV Gel and PCR clean up system	Promega, # A9282
Zirconium silica beads ( $\varnothing = 0.5$ mm)	Stratech, #11079105z

## 2.2 Media reagents

**Table 2.2 List of media reagents used in this study**

<b>Media</b>	<b>Company, Cat.No</b>
YNB agar	Formedium, # CCMO210
YNB broth	Formedium, # CCMO110
YNB w/o a.a.	Formedium, # CYNO405
Bacto-peptone	BD, # 211677
Bacto-yeast extract	BD, # 212750
Agar	Fisher Scientific, # 9002-18-0
Single drop out (SD-Trp)	Formedium, # DSCK092

### 2.3 Commercial antibiotics, enzymes and antibodies

**Table 2.3 List of commercial antibiotics, enzymes and antibodies used in this study**

Antibiotics/enzymes/antibodies	Company, Cat.No
RNase A, 10-20 mg/ml, DNase-free	Fermentas, # EN0531
GoTaq DNA polymerase (5 U/ $\mu$ l)	Promega, Southampton, UK, # M8305
Tunicamycin ( <i>Streptomyces lysosuperficus</i> )	Calbiochem, # 654380
G-418	Melford, # G0175
Kanamycin	Gibco, # 11815-024
anti-H3 total antibody.	Abcam, Cambridge, UK, # ab1791
anti-acetyl histone H3 K9	Millipore, Watford, UK, # 07-352
anti-acetyl histone H3 K18	Abcam, # ab1191
anti-acetyl histone H4 K8	Millipore, # 07-328
anti-Pol II antibody	Abcam, # ab5408
anti-Pol II serine 5 phosphorylation antibody	Abcam, # ab5131
anti-Pol II serine 2 phosphorylation antibody	Abcam, # ab5095
anti-MYC (9B11) antibody	Cell Signaling Technology, #2276
anti-HA antibody	Sigma-Aldrich, #H6908

## 2.4 The plasmids used in this study

Table 2.4 below lists the plasmids used in this study:

Plasmid	Features	Reference
pFA6a-kanMX2	$P_{TEF}$ -kanMX2- $T_{TEF}$ <i>bla</i>	(Wach et al., 1994)
pRS314	<i>CEN6 ARSH4 TRP1 bla</i>	(Sikorski and Hieter, 1989)
pRS314- <i>HAC1<sup>i</sup></i>	<i>CEN6 ARSH4 TRP1 HA-HAC1<sup>i</sup> bla</i>	(Schröder et al., 2004)



## 2.5 Yeast strains used in this study

All strains are in the SK1 genetic background (Kane and Roth, 1974). All haploid SK1 strains have the additional alleles *ura3 leu2::hisG trp1::hisG lys2 ho::LYS2*. The alleles *arg6* (Neugeborn and Mitchell, 1991), *hac1Δ::TRP1* (Schröder et al., 2003), *his3ΔSK* (Neugeborn and Mitchell, 1991), *ho::hisG* (Alani et al., 1987), *ho::LYS2* (Alani et al., 1987), *ire1Δ::kanMX2* (Schröder et al., 2000), *leu2::hisG* (Alani et al., 1987), *lys2* (Alani et al., 1987), *met4* (Neugeborn and Mitchell, 1991), *rme1Δ5::LEU2* (Covitz et al., 1991), *rpd3Δ::natMX4* (Schröder et al., 2004), *rpd3Δ::URA3* (Lamb and Mitchell, 2001), *sds3Δ::URA3* (Dorland et al., 2000), *SIN3-MYC* (Lamb and Mitchell, 2001), *sin3Δ::LEU2* (Lamb and Mitchell, 2001), *trp1::hisG* (Alani et al., 1987), and *ura3* (Alani et al., 1987) have been described before.

Strain	Genotype	Reference
MSY 36-34	$\alpha$ <i>arg6</i>	Schröder lab strain inventory
MSY 42-38	$\alpha$ <i>arg6 rpd3Δ::URA3</i>	Schröder lab strain inventory
MSY 49-06	$\alpha$ <i>arg6 sin3Δ::LEU2</i>	(Schröder et al., 2004)
MSY 56-01	$\alpha$ <i>arg6 sds3Δ::URA3</i>	(Schröder et al., 2004)
MSY 134-36	<b>a</b> <i>arg6 rme1Δ5::LEU2</i>	(Schröder et al., 2004)
MSY 136-40	$\alpha$ <i>arg6 rme1Δ5::LEU2</i>	(Schröder et al., 2004)
MSY 138-17	$\alpha$ <i>his3ΔSK rme1Δ5::LEU2</i>	(Schröder et al., 2004)
MSY 211-02	<b>a</b> <i>arg6 rme1Δ5::LEU2 hac1Δ::TRP1</i>	(Schröder et al., 2004)
MSY 287-01	<b>a</b> <i>arg6 rme1Δ5::LEU2 rpd3Δ::kanMX2</i>	(Schröder et al., 2004)
MSY 288-01	$\alpha$ <i>arg6 rme1Δ5::LEU2 rpd3Δ::kanMX2</i>	(Schröder et al., 2004)
MSY 291-01	<b>a</b> <i>arg6 rme1Δ5::LEU2 rpd3Δ::natMX4</i>	(Schröder et al., 2004)
MSY 296-01	$\alpha$ <i>his3ΔSK rme1Δ5::LEU2 hac1Δ::kanMX2</i>	This study (Dr Schröder)

MSY 307-03	<b>a</b> <i>arg6 rme1Δ5::LEU2 rpd3Δ::natMX4 hac1Δ::TRP1</i>	Schröder lab strain inventory
MSY 358-03	$\alpha$ <i>arg6 rme1Δ5::LEU2 rpd3Δ::Ura3 H150A-rpd3-FLAG-TCYC8</i>	(Schröder et al., 2004)
MSY 359-01	$\alpha$ <i>arg6 rme1Δ5::LEU2 rpd3Δ::Ura3 H151A-rpd3-FLAG-TCYC8</i>	(Schröder et al., 2004)
MSY 525-07	$\alpha$ <i>his3ΔSK rme1Δ5::LEU2 ire1Δ::kanMX2</i>	Schröder lab strain inventory
MSY 718-01	<b>a</b> <i>arg6 rme1Δ5::LEU2 gcn5Δ::kanMX2</i>	This study (Dr Dainty)
MSY 732-01	$\alpha$ <i>arg6 rme1Δ5::LEU2 eaf3Δ::kanMX2</i>	This study (Dr Parmar)
MSY 703-01	$\alpha$ <i>arg6 rme1Δ5::LEU2 rco1Δ::kanMX2</i>	This study (Dr Parmar)
MSY 726-03	<b>a</b> <i>arg6 rme1Δ5::LEU2 SDS3-MYC18-natMX4</i>	This study (Dr Dainty)
MSY 727-03	<b>a</b> <i>arg6 rme1Δ5::LEU2 SIN3-MYC hac1Δ::TRP1</i>	This study (Dr Schröder)
MSY 728-07	<b>a</b> <i>arg6 rme1Δ5::LEU2 SDS3-MYC18-natMX4 hac1Δ::TRP1</i>	This study (Dr Schröder)
MSY 721-01	<b>a</b> <i>arg6 rme1Δ5::LEU2 GCN5-13MYC</i>	This study (Dr Dainty)
TLY 446	<b>a</b> <i>arg6 rme1Δ5::LEU2 SIN3-MYC</i>	(Lamb and Mitchell, 2001)

---

## 2.6 Oligonucleotides used in this study

The oligodeoxynucleotides were synthesized by Eurogentec Ltd. Lyophilised primers were resuspended in sterile water to a final concentration of 100µM and stored in -20°C. The oligonucleotides used in this study are listed in Table 2.6

Name	Purpose	Sequence
H8051	<i>HSP12</i> probe PCR, forward primer	CGCAGGTAGAAAAGGATTTCG
H8052	<i>HSP12</i> probe PCR, reverse primer	TCAGCGTTATCCTTGCCTTT
H8053	<i>STL1</i> probe PCR, forward primer	CTTCAGAGGGCTTTGATTGC
H8054	<i>STL1</i> probe PCR, reverse primer	TGAAACTGCTTGACCTGTGG
H8055	<i>CTT1</i> probe PCR, forward primer	GACTTCGAACAGCCAAGAGC
H8056	<i>CTT1</i> probe PCR, reverse primer	TAATTGGCACTTGCAATGGA
H8057	<i>ALD3</i> probe PCR, forward primer	ATGCGGTGGTAAGTCTCCTG
H8058	<i>ALD3</i> promoter PCR, reverse primer	TCCCACTCCTTCTTTGCAGT
H8249	<i>HSP12</i> promoter PCR, forward primer	GAGGGGAAAAGGAAAAGGAAAAG
H8250	<i>HSP12</i> promoter PCR, reverse primer	GAGGAAGTAGAACGCAATTC
H8253	<i>STL1</i> promoter PCR, forward primer	TTGCAGTTCAGGAGTAGTCACA
H8254	<i>STL1</i> promoter PCR, reverse primer	AAATTTGCCTTTGAAATTCGAT
H8255	<i>CTT1</i> promoter PCR, forward primer	CGTATCCCCTACTGCTACACG
H8256	<i>CTT1</i> promoter PCR, reverse primer	ACCGAACACGTTTCATTTGTG

H8257	<i>ALD3</i> promoter PCR, forward primer	AAAATGGCAAATCTGGATG
H8258	<i>ALD3</i> promoter PCR, reverse primer	TTTTCAATTGTGGGATTTTCG
H8400	<i>ALD3</i> ORF, 3' end PCR, forward primer	GCGGTCTTCACCAAAGATGT
H8401	<i>ALD3</i> ORF, 3' end PCR, reverse primer	TGAAAGATCCACATGGACTGA
H8402	<i>CTT1</i> ORF, 3' end PCR, forward primer	TTCGTTCATAACGTTGTTTGC
H8403	<i>CTT1</i> ORF, 3' end PCR, reverse primer	CCTTCAAGGTCAACAGGTTCC
H8404	<i>STL1</i> ORF, 3' end PCR, forward primer	AACCATTTGCCCAAGTTATCC
H8405	<i>STL1</i> ORF, 3' end PCR, reverse primer	CCCTCAAATTTGCTTTATCG
H8408	<i>HSP12</i> ORF, 3' end PCR, forward primer	AACAAGGGTGTCTTCCAAGG
H8409	<i>HSP12</i> ORF, 3' end PCR, reverse primer	TTGGTTGGGTCTTCTCACC

---

## 2.7 Preparation of yeast media buffers and stock solutions:

### 2.7.1 Preparation of stock solutions

Solution	Quantity	Recipe
EDTA, 0.5 M	500 ml	<ol style="list-style-type: none"> <li>Dissolve 93.1 g Na<sub>2</sub>EDTA·2H<sub>2</sub>O in ~350 ml H<sub>2</sub>O and adjust pH to 8.0 with 10 M NaOH (~25 ml).</li> <li>Add H<sub>2</sub>O to 500 ml. and autoclave.</li> </ol>
HEPES (pH 7.5), 1 M	100 ml	<ol style="list-style-type: none"> <li>Dissolve 23.83 g HEPES in ~80 ml autoclaved H<sub>2</sub>O. and adjust pH to 7.5 with KOH. Then add H<sub>2</sub>O to 100 ml.</li> <li>Autoclave.</li> </ol>
MgCl <sub>2</sub> , 1 M	100 ml	<ol style="list-style-type: none"> <li>Dissolve 20.33 g MgCl<sub>2</sub>·6 H<sub>2</sub>O in ~ 80 ml H<sub>2</sub>O and add H<sub>2</sub>O to 100 ml.</li> <li>Autoclave.</li> </ol>
Na <sub>2</sub> CO <sub>3</sub> , 1 M	500 ml	<ol style="list-style-type: none"> <li>Dissolve 53.0 g Na<sub>2</sub>CO<sub>3</sub> in ~ 400 ml H<sub>2</sub>O.</li> <li>Add H<sub>2</sub>O to 500 ml.</li> </ol>
NaH <sub>2</sub> PO <sub>4</sub> , 0.2 M	500 ml	<ol style="list-style-type: none"> <li>Dissolve 12 g NaH<sub>2</sub>PO<sub>4</sub> in ~400 ml H<sub>2</sub>O.</li> <li>Add H<sub>2</sub>O to 500 ml.</li> <li>Autoclave.</li> </ol>
NaH <sub>2</sub> PO <sub>4</sub> , 0.4 M	500 ml	<ol style="list-style-type: none"> <li>Dissolve 24 g NaH<sub>2</sub>PO<sub>4</sub> in ~400 ml H<sub>2</sub>O.</li> <li>Add H<sub>2</sub>O to 500 ml.</li> <li>Autoclave.</li> </ol>
Na <sub>2</sub> HPO <sub>4</sub> , 0.2 M	500 ml	<ol style="list-style-type: none"> <li>Dissolve 14.2 g Na<sub>2</sub>HPO<sub>4</sub> (35.82 g Na<sub>2</sub>HPO<sub>4</sub>·12 H<sub>2</sub>O) in ~400 ml H<sub>2</sub>O.</li> <li>Add H<sub>2</sub>O to 500 ml.</li> <li>Autoclave.</li> </ol>
Na <sub>2</sub> HPO <sub>4</sub> , 0.4 M	500 ml	<ol style="list-style-type: none"> <li>Dissolve 28.4 g Na<sub>2</sub>HPO<sub>4</sub> in ~400 ml H<sub>2</sub>O.</li> <li>Add H<sub>2</sub>O to 500 ml.</li> <li>Autoclave.</li> </ol>
NaOAc (pH 6.0), 3 M	100 ml	<ol style="list-style-type: none"> <li>Dissolve 40.83 g NaOAc·3H<sub>2</sub>O in ~60 ml H<sub>2</sub>O and adjust pH to 6.0 with glacial HOAc</li> <li>Add H<sub>2</sub>O to 100 ml.</li> <li>Autoclave.</li> </ol>
NaOH, 10 M	500 ml	<ol style="list-style-type: none"> <li>Dissolve 200 g NaOH in ~350 ml H<sub>2</sub>O. <i>Solution will get very hot!</i></li> <li>Store in a polyethylene bottle.</li> </ol>
NH <sub>4</sub> OAc, 10 M	100 ml	<ol style="list-style-type: none"> <li>Dissolve 77.08 g NH<sub>4</sub>OAc in a small amount of H<sub>2</sub>O and add H<sub>2</sub>O to 100 ml.</li> <li>Autoclave.</li> </ol>
10% (w/v) NP-40	50 ml	<ol style="list-style-type: none"> <li>Dissolve 5.55 g NP-40 in ~ 40 ml autoclaved H<sub>2</sub>O and add H<sub>2</sub>O to 50 ml. Filter sterilize.</li> </ol>
10% (w/v) SDS		<ol style="list-style-type: none"> <li>Dissolve 50 g SDS in ~450 ml H<sub>2</sub>O and add H<sub>2</sub>O to 500 ml.</li> <li>Do <b>NOT</b> autoclave.</li> </ol>
Tris-HCl (pH 6.8), 1 M	1 l	<ol style="list-style-type: none"> <li>Dissolve 121.14 g Tris in ~800 ml H<sub>2</sub>O.</li> <li>Adjust pH to 6.8 with conc. HCl (~ 42 ml).</li> <li>Add H<sub>2</sub>O to 1 l and autoclave.</li> </ol>
Tris-HCl (pH 8.0), 1 M	1 l	<ol style="list-style-type: none"> <li>Dissolve 121.14 g Tris in ~800 ml H<sub>2</sub>O. and adjust pH to 8.0 with conc. HCl (~ 42 ml).</li> <li>Add H<sub>2</sub>O to 1 l and autoclave.</li> </ol>

<b>10% (v/v) Triton X-100</b>	50 ml	1. Dissolve 5.55 g Tween 20 in ~ 40 ml autoclaved H <sub>2</sub> O and add H <sub>2</sub> O to 50 ml. Filter sterilize.
<b>10% (v/v) Tween 20</b>	50 ml	1. Dissolve 5.55 g Tween 20 in ~ 40 ml autoclaved H <sub>2</sub> O and add H <sub>2</sub> O to 50 ml. 2. Filter sterilize.

### 2.7.2 Buffers

Buffer	Composition	Quantity	Recipe
<b>10 x PBS</b>	80 g/l NaCl 2 g/l KCl 14.4 g/l Na <sub>2</sub> HPO <sub>4</sub> 2 g/l KH <sub>2</sub> PO <sub>4</sub>	4 l	1. To 320 g NaCl, 8 g/l KCl, 57.6 g/l Na <sub>2</sub> HPO <sub>4</sub> and 8 g/l KH <sub>2</sub> PO <sub>4</sub> add H <sub>2</sub> O to 4 l. Dissolve all salts by stirring and <b>autoclave</b>
<b>1 x PBS</b>	8.0 g/l NaCl 0.2 g/l KCl 14.4 g/l Na <sub>2</sub> HPO <sub>4</sub> 0.2 g/l KH <sub>2</sub> PO <sub>4</sub>	1 l	2. 100 ml 10 x PBS 3. Add sterile H <sub>2</sub> O to 1 l.
<b>50 x TAE</b>	2 M Tris-HOAc 0.1 M EDTA pH ~ 8.5	1 l	1. 242 g Tris 2. 57.1 ml HOAc 3. 37.2 g Na <sub>2</sub> EDTA·2H <sub>2</sub> O 4. Add H <sub>2</sub> O to 1 l
<b>1 x TAE</b>	40 mM Tris-HOAc 2 mM M EDTA pH ~ 8.5	1 l	1. 20 ml 50 x TAE 2. Add H <sub>2</sub> O to 1 l
<b>10 x TE (pH 8.0)</b>	100 mM Tris-HCl (pH 8.0) 10 mM EDTA	4 l	400 ml 1 M Tris-HCl (pH 8.0) 80 ml 0.5 M EDTA Add H <sub>2</sub> O to 4 l Autoclave
<b>1 x TE (pH 8.0)</b>	10 mM Tris-HCl (pH 8.0) 1 mM EDTA	50 ml	5 ml 10 x TE (pH 8.0) Add sterile H <sub>2</sub> O to 50 ml

### 2.7.3 Specialised solutions

Solution	Composition	Quantity	Recipe
<b>ChIP elution buffer</b>	50 mM Tris-HCl (pH 8.0) 10 mM EDTA 1 % (w/v) SDS	50 ml	2.5 ml 1 M Tris-HCl (pH 8.0) 1.0 ml 0.5 M EDTA 5.0 ml 10% (w/v) SDS 41.5 ml H <sub>2</sub> O (autoclaved)

<b>ChIP lysis buffer</b>	50 mM HEPES-KOH, (pH 7.5) 500 mM NaCl 1 mM EDTA 1.0 % (v/v) Triton X-100 0.1% (v/v) SDS 0.1% (w/v) sodium deoxycholate	500 ml	<ol style="list-style-type: none"> <li>1. Dissolve 14.61 g NaCl, 0.5 g sodium deoxycholate, 25 ml 1 M HEPES-KOH (pH 7.5), and 1 ml 0.5 M EDTA in ~350 ml H<sub>2</sub>O. Make up to 445 ml and autoclave. Then add:</li> <li>2. 50 ml 10% (v/v) Triton X-100 and 5 ml 10% (w/v) SDS.</li> </ol>
<b>Deoxycholate buffer</b>	10 mM Tris-HCl (pH 8.0) 1 mM EDTA 0.25 M LiCl 0.5% (v/v) NP-40 0.5% (w/v) sodium deoxycholate	100 ml	<ol style="list-style-type: none"> <li>1. Dissolve 1 ml 1 M Tris-HCl (pH 8.0), 200 µl 0.5 M EDTA, 1.06 g LiCl, and 0.5 g sodium deoxycholate in ~80 ml H<sub>2</sub>O. Make up to 95 ml and autoclave. Then add:</li> <li>2. 5 ml 10% (v/v) NP-40.</li> </ol>
<b>1 M dithiothreitol</b>	1 M dithiothreitol (DTT)	10 ml	<ol style="list-style-type: none"> <li>1. 1.54g dithiothreitol</li> <li>2. Dissolve in ~ 9 ml H<sub>2</sub>O.</li> <li>3. Add H<sub>2</sub>O to 10 ml.</li> <li>4. Filter sterilize.</li> <li>5. Store at -20°C.</li> </ol>
<b>2 mM dNTPs</b>	2 mM dATP 2 mM dCTP 2 mM dGTP 2 mM dTTP 1 mM Tris-HCl (pH 8.0)	1 ml	<ol style="list-style-type: none"> <li>1. 910 µl H<sub>2</sub>O 10 µl 100 mM Tris-HCl (pH 8.0)</li> <li>2. 20 µl 100 mM dATP 20 µl 100 mM dCTP 20 µl 100 mM dGTP 20 µl 100 mM dTTP</li> </ol>
<b>5.0 mg/ml ethidium bromide</b>	5.0 mg/ml ethidium bromide	50 ml	<ol style="list-style-type: none"> <li>1. 250 mg ethidium bromide</li> <li>2. Dissolve in ~ 40 ml sterile H<sub>2</sub>O.</li> <li>3. Add sterile H<sub>2</sub>O to 50 ml.</li> <li>4. Store at 4°C protected from light.</li> </ol>
<b>5 M KOAc, pH 4.8</b>	5 M KOAc, pH 4.8	500 ml	<ol style="list-style-type: none"> <li>1. 147.5 ml HOAc, add H<sub>2</sub>O to ~ 450 ml, adjust pH to 4.8 w/ KOH pellets while cooling in an ice/H<sub>2</sub>O bath. Add H<sub>2</sub>O to 500 ml and autoclave.</li> </ol>
<b>1 M LiOAc</b>	1 M LiOAc	250 ml	<ol style="list-style-type: none"> <li>1. 25.50 g LiOAc·2H<sub>2</sub>O</li> <li>2. Dissolve in ~200 ml H<sub>2</sub>O.</li> <li>3. Add H<sub>2</sub>O to 250 ml.</li> <li>4. Filter sterilize.</li> </ol>
<b>20 µg/µl Proteinase K</b>	20 µg/µl Proteinase K 50 mM Tris-HCl (pH 8.0)	500 µl	<ol style="list-style-type: none"> <li>1. Dissolve 10 mg proteinase K in 500 µl 50 mM Tris-HCl (pH 8.0). Dispense into 20 µl portions and store at -20°C.</li> </ol>
<b>Triton X-100 solution</b>	2% (v/v) Triton X-100 50 mM Tris-HCl (pH 8.0)	1 l	<ol style="list-style-type: none"> <li>1. Dissolve 21 g Triton X-100 and 50 ml 1 M Tris-HCl (pH 8.0) in H<sub>2</sub>O, add H<sub>2</sub>O to 1 l, and filter sterilize.</li> </ol>

### 2.7.4 Solutions for RNA work

**General guidelines:** Fresh pair of gloves is always used for RNA work. There are a separate set of chemicals, glassware, and plastic materials dedicated for work with RNA. All glassware, all stir bars, and all metal spatulas used for work with RNA are sterilized by baking for  $\geq 4$  h at 180°C. Baked glassware is always used to prepare solutions. Plastic materials (for example: 15 ml centrifuge tubes, 50 ml centrifuge tubes, 1.5 ml microcentrifuge tubes) used for RNA work is always purchased with packaging under sterile conditions. Electrophoresis equipment is cleaned thoroughly with 2% (w/v) SDS and rinsed with type I laboratory water before use. A final wash is given with DEPC water. Hybridization bottles need to be clean, but sterilization by autoclaving or baking is not necessary (and may be detrimental to the bottles). DEPC is always handled in a fume hood.

#### 2.7.4.1 Preparation of RNA reagents

Reagent	Recipe
<b>Formamide</b>	<ol style="list-style-type: none"> <li>Mix 100 ml formamide with 5 g Dowex MR-3 mixed bed ion exchanger for 1 h at RT.</li> <li>Separate the Dowex MR-3 mixed bed ion exchanger from the formamide by filtration in a sterile filter unit.</li> <li>Store formamide at 4°C protected from light for <math>\sim 1</math> year.</li> </ol>
<b>6 M glyoxal</b>	<ol style="list-style-type: none"> <li>Mix 50 ml 40% (w/w) glyoxal (= 6 M) w/ 5 g Dowex MR-3 mixed bed ion exchanger for 1 h at RT.</li> <li>Separate the Dowex MR-3 mixed bed ion exchanger from the glyoxal solution by filtration in a sterile filter unit.</li> <li>Store glyoxal at -20°C for a 1 year in 0.5 ml aliquots.</li> </ol>
<b>Phenol: CHCl<sub>3</sub>:isoamyl-alcohol (25:24:1 (v/v/v)), saturated with RNA buffer</b>	<ol style="list-style-type: none"> <li>Add 25 ml RNA buffer to 25 ml phenol: CHCl<sub>3</sub>:isoamylalcohol (25:24:1 (v/v/v)), buffered w/ 0.1 M Tris-HCl (pH 8.0) in a 50 ml tube. Mix phases by vortexing.</li> <li>Separate phases by centrifugation at 3000 rpm, 4°C for 2 min.</li> <li>Completely remove the upper, aqueous phase.</li> <li>Repeat steps 1 – 3 once. This time leave <math>\sim 5</math> ml aqueous phase on top of the phenol: CHCl<sub>3</sub>: isoamylalcohol (25:24:1 (v/v/v)) saturated with RNA buffer.</li> <li>Store protected from light at 4°C.</li> </ol>



## 2.7.4.2 Solutions that can be treated with DEPC

Solution	Composition	Quantity	Recipe
DEPC-H <sub>2</sub> O	H <sub>2</sub> O	1 l	1. Add 1 ml DEPC to 1 l of type I laboratory H <sub>2</sub> O. Vigorously stir for 30 min at RT and autoclave.
200 mM NaH <sub>2</sub> PO <sub>4</sub>	200 mM NaH <sub>2</sub> PO <sub>4</sub>	500 ml	1. Dissolve 12.21 g NaH <sub>2</sub> PO <sub>4</sub> in ~450 ml DEPC-H <sub>2</sub> O, add DEPC-H <sub>2</sub> O to 500 ml. 2. Add 0.5 ml DEPC and stir for 30 min at RT. 3. Autoclave.
200 mM Na <sub>2</sub> HPO <sub>4</sub>	200 mM Na <sub>2</sub> HPO <sub>4</sub>	500 ml	1. Dissolve 14.21 g Na <sub>2</sub> HPO <sub>4</sub> (35.82 g Na <sub>2</sub> HPO <sub>4</sub> ·12 H <sub>2</sub> O) in ~450 ml DEPC-H <sub>2</sub> O, add DEPC-H <sub>2</sub> O to 500 ml and add 0.5 ml DEPC and stir for 30 min at RT and autoclave.
100 mM Na <sub>x</sub> H <sub>3-x</sub> PO <sub>4</sub> (pH 7.0)	100 mM Na <sub>x</sub> H <sub>3-x</sub> PO <sub>4</sub> (pH 7.0)	1 l	1. To 195 ml 200 mM NaH <sub>2</sub> PO <sub>4</sub> and 305 ml 200 mM Na <sub>2</sub> HPO <sub>4</sub> . 2. Add DEPC-H <sub>2</sub> O to 1 l, Add 1 ml DEPC, stir 30 min at RT and autoclave.
10 mM Na <sub>x</sub> H <sub>3-x</sub> PO <sub>4</sub> (pH 7.0)	10 mM Na <sub>x</sub> H <sub>3-x</sub> PO <sub>4</sub> (pH 7.0)	1 l	1. 100 ml 100 mM Na <sub>x</sub> H <sub>3-x</sub> PO <sub>4</sub> (pH 7.0). 2. Add DEPC-H <sub>2</sub> O to 1 l.
6 x RNA sample loading buffer	50% (v/v) glycerol 10 mM Na <sub>x</sub> H <sub>3-x</sub> PO <sub>4</sub> (pH 7.0) 0.4% (w/v) bromophenol blue	100 ml	1. To 63 g glycerol and 250 mg bromophenol blue add 10 ml 100 mM Na <sub>x</sub> H <sub>3-x</sub> PO <sub>4</sub> (pH 7.0) and DEPC-H <sub>2</sub> O to ~90 ml. 2. Stir until bromophenol blue is dissolved. 3. Add DEPC-H <sub>2</sub> O to 100 ml. 4. Add 100 µl DEPC and stir 30 min at RT. 5. Autoclave.
20 x SSC	3 M NaCl 0.3 M Na <sub>3</sub> ·citrate	1 l	1. Dissolve 175.32 g NaCl and 88.23 g Na <sub>3</sub> ·citrate-2 H <sub>2</sub> O in ~900 ml DEPC-H <sub>2</sub> O. Add DEPC-H <sub>2</sub> O to 1 l. 2. Add 1 ml DEPC, and stir at RT for 30 min. Vigorous stirring may be necessary to disperse the DEPC in the 20 x SSC, 3. Autoclave.
6 x SSC	0.9 M NaCl 90 mM Na <sub>3</sub> ·citrate	500 ml	1. To 150 ml of 20 x SSC, add DEPC-H <sub>2</sub> O to 500 ml.
2 x SSC	0.3 M NaCl 30 mM Na <sub>3</sub> ·citrate	500 ml	2. To 50 ml 20 x SSC, add DEPC-H <sub>2</sub> O to 500 ml.

**2.7.4.3 Solutions that can be treated with DEPC but cannot be autoclaved**

<b>Solution</b>	<b>Composition</b>	<b>Quantity</b>	<b>Recipe</b>
<b>10% (w/v) SDS</b>	10% (w/v) SDS	500 ml	<ol style="list-style-type: none"> <li>1. Dissolve 50 g SDS in 450 ml DEPC-H<sub>2</sub>O.</li> <li>2. Add DEPC-H<sub>2</sub>O to 500 ml.</li> <li>3. Add 500 µl DEPC and stir 30 min at RT.</li> <li>4. Incubate o/n at 60°C.</li> </ol>
<b>2 x SSC + 0.1% (w/v) SDS</b>	0.3 M NaCl 30 mM Na <sub>3</sub> ·citrate 0.1% (w/v) SDS	500 ml	<ol style="list-style-type: none"> <li>1. 50 ml 20 x SSC</li> <li>2. ml 10% (w/v) SDS</li> <li>3. Add DEPC-H<sub>2</sub>O to 500 ml.</li> </ol>
<b>0.2 x SSC + 0.1% (w/v) SDS</b>	30 mM NaCl 3 mM Na <sub>3</sub> ·citrate 0.1% (w/v) SDS	500 ml	<ol style="list-style-type: none"> <li>5 ml 20 x SSC</li> <li>5 ml 10% (w/v) SDS</li> <li>Add DEPC-H<sub>2</sub>O to 500 ml.</li> </ol>

**2.7.4.4 Solutions that cannot be treated with DEPC but can be autoclaved**

<b>Solution</b>	<b>Composition</b>	<b>Quantity</b>	<b>Recipe</b>
<b>0.5 M EDTA (pH 8.0)</b>	0.5 M EDTA (pH 8.0)	500 ml	<ol style="list-style-type: none"> <li>1. Dissolve 93.05 g Na<sub>2</sub>EDTA·2H<sub>2</sub>O in ~ 350 ml DEPC-H<sub>2</sub>O.</li> <li>2. Adjust pH w/ 10 N NaOH.</li> <li>3. Add DEPC-H<sub>2</sub>O to 500 ml.</li> <li>4. Autoclave.</li> </ol>
<b>1 M Tris·HCl (pH 7.5)</b>	1 M Tris·HCl (pH 7.5)	500 ml	<ol style="list-style-type: none"> <li>1. Dissolve 60.57 g Tris in ~ 400 ml DEPC-H<sub>2</sub>O.</li> <li>2. Adjust pH w/ conc. HCl.</li> <li>3. Add DEPC-H<sub>2</sub>O to 500 ml.</li> <li>4. Autoclave.</li> </ol>
<b>1 M Tris·HCl (pH 8.0)</b>	1 M Tris·HCl (pH 8.0)	500 ml	<ol style="list-style-type: none"> <li>1. Dissolve 60.57 g Tris in ~ 400 ml DEPC-H<sub>2</sub>O.</li> <li>2. Adjust pH w/ conc. HCl.</li> <li>3. Add DEPC-H<sub>2</sub>O to 500 ml.</li> <li>4. Autoclave.</li> </ol>
<b>20 mM Tris·HCl (pH 8.0)</b>	20 mM Tris·HCl (pH 8.0)	500 ml	<ol style="list-style-type: none"> <li>1. Add DEPC-H<sub>2</sub>O to 500 ml to 10 ml 1 M Tris·HCl (pH 8.0).</li> </ol>

**2.7.4.5 Composite solutions**

<b>Solution</b>	<b>Composition</b>	<b>Quantity</b>	<b>Recipe</b>
<b>100 x Denhardt's solution</b>	2% (w/v) Ficoll 400 2% (w/v) polyvinylpyrrolidone 2% (w/v) BSA (fraction V)	500 ml	<ol style="list-style-type: none"> <li>1. 10 g Ficoll 400</li> <li>2. 10 g polyvinylpyrrolidone</li> <li>3. 10 g BSA (fraction V)</li> <li>4. Dissolve in DEPC-H<sub>2</sub>O. Add DEPC-H<sub>2</sub>O to 500 ml and filter sterilize. Store at 4°C.</li> </ol>

<b>70% (v/v) EtOH</b>	70% (v/v) EtOH	50 ml	Mix 35 ml EtOH and 15 ml DEPC-H <sub>2</sub> O and store at -20°C.
<b>RNA buffer</b>	0.5 M NaCl 0.2 M Tris-HCl (pH 7.5) 10 Mm EDTA	500 ml	<ol style="list-style-type: none"> <li>1. Dissolve 14.61 g NaCl in 390 ml DEPC-H<sub>2</sub>O.</li> <li>2. Add 390 ml DEPC and stir 30 min at RT.</li> <li>3. Autoclave.</li> <li>4. Add 100 ml 1 M Tris-HCl (pH 7.5) and 10 ml 0.5 M EDTA (pH 8.0)</li> </ol>

## 2.8 Microbiological Media

**General guidelines:** Solutions are prepared in type I laboratory H<sub>2</sub>O (resistivity 18 MΩ•cm, total organic carbon < 20 ppb, microorganisms < 1 cfu/ml, particles < 0.05 µm diameter) generated by the NANOpure Diamond UV/UF TOC water purification system and sterilized by autoclaving (121°C, 20 – 30 min) or filter sterilized over a 0.22 µm filter when indicated.

### 2.8.1 Liquid media for *Saccharomyces cerevisiae*

Medium	Composition	Quantity	Recipe
<b>YPAc broth</b>	1% (w/v) bacto-yeast extract 2% (w/v) bacto-peptone 2% (w/v) KOAc	1l	<ol style="list-style-type: none"> <li>1. Dissolve 10 g bacto-yeast extract, 20 g bacto-peptone, and 20 g KOAc in ~ 800 ml H<sub>2</sub>O.</li> <li>2. Add H<sub>2</sub>O to 1 l and mix.</li> <li>3. Dispense into bottles.</li> <li>4. Autoclave.</li> </ol>
<b>YPD broth</b>	1% (w/v) bacto-yeast extract 2% (w/v) bacto-peptone 2% (w/v) D-glucose	1 l	<ol style="list-style-type: none"> <li>1. Dissolve 50 g YPD broth powder in ~800 ml H<sub>2</sub>O.</li> <li>2. Add H<sub>2</sub>O to 1 l and mix.</li> <li>3. Dispense into bottles.</li> <li>4. Autoclave.</li> </ol>

## 2.8.2 Solid media

Medium	Composition	Quantity	Recipe
<b>YPAc agar</b> label:	1% (w/v) bacto-yeast extract 2% (w/v) bacto-peptone 2% (w/v) KOAc 2% (w/v) agar	1 l	<ol style="list-style-type: none"> <li>Add 1 l H<sub>2</sub>O to 10 g bacto-yeast extract, 20 g bacto-peptone, 20 g KOAc, and 20 g agar in a 2 l Erlenmeyer flask.</li> <li>Stir until suspension is homogenous and then autoclave. Let solution cool to ~55°C. Pour ~25 ml into one 90 mm Petri dish.</li> </ol>
<b>YPD agar</b> label:	1% (w/v) bacto-yeast extract 2% (w/v) bacto-peptone 2% (w/v) D-glucose 1.5% (w/v) agar	1 l	<ol style="list-style-type: none"> <li>Add 1 l H<sub>2</sub>O to 65 g YPD agar powder in a 2 l Erlenmeyer flask. Stir until suspension is homogenous and then autoclave. Let solution cool to ~55°C. Pour ~25 ml into one 90 mm Petri dish.</li> </ol>
<b>YPD + 400 µg/ml G418 agar</b> label:   + 400 µg/ml G418	1% (w/v) bacto-yeast extract 2% (w/v) bacto-peptone 2% (w/v) D-glucose 1.5% (w/v) agar 400 µg/ml G418	1 l	<ol style="list-style-type: none"> <li>Follow step 1 from above.</li> <li>Let solution cool to ~55°C. Add 400 mg G418 and mix until G418 has dissolved. Pour ~25 ml into one 90 mm Petri dish.</li> </ol>

## 2.9 Yeast Transformation

Plasmids, yeast strains and oligonucleotides used are listed in Tables 2.4, 2.5 and 2.6 respectively. Isogenic yeast strains were used for all experiments. Strains lacking functional tryptophan gene were transformed with an empty vector pRS314 (Table 2.4). Yeast strains were transformed by the LiOAc method (Chen et al., 1992). The LiOAc protocol for plasmid transformation is described below.

**2.9.1 Reagents:** Sterile water, 1 M LiOAc, filter sterilized (pH 8.4-8.9), 50% (w/v) PEG4000, One step buffer (0.2 M LiOAc and 40% (w/v) PEG4000), 8.31mg/ml or 6.89mg/ml sheared salmon sperm DNA and appropriate agar plates.

**2.9.2 Protocol:** The yeast cells were inoculated and grown to an OD of 0.8-1.2 from an overnight preculture. 5ml of the yeast cell culture at 0.8-1.2 OD was collected by centrifugation for 2 min at 3000rpm at 4°C. The supernatant was decanted and the cells were placed on ice. While the cells

were centrifuging, the sheared salmon sperm DNA was thawed at 37°C water bath and put on ice. The cell pellet was resuspended in 5-10 ml of one-step buffer and centrifuge for 2 min at 3000rpm at 4°C. While the cells were centrifuging, the salmon sperm DNA was boiled for 5 min at 100°C and place on ice. The transforming DNA was dispensed in 1.5 ml microcentrifuge tubes and place on ice. 12 µl 8.31 mg/ml (14.5 µl 6.89 mg/ml) sheared salmon sperm DNA was added to each tube containing the transforming DNA using a large orifice pipette tip. After centrifugation, the supernatant was decanted and the cells were placed on ice. All the liquid was pipetted out. 88 µl of one-step buffer was added to a cell pellet obtained from 5 ml YPD broth. For a cell pellet obtained from a larger culture a proportional amount of one-step buffer was further added. The cells were resuspended by vortexing and checked for presence of cell clumps.. 88 µl of the yeast cells and one step buffer suspensions was added to tubes containing transforming DNA and 100 µg sheared salmon sperm DNA using large orifice pipette tips. The tubes were vortexed for 15 s at maximum speed. The cells were incubated in a 42°C water bath for 30 min without mixing and then placed on ice. The cells were collected by centrifugation in a microcentrifuge for 10 s at RT. The cells were placed on ice and the supernatant is pipetted out completely. The cells were resuspended in 200µl of water and spread on appropriate agar plates. Transformations that introduce nutritional markers were usually plated directly onto the selective plate. Transformations that introduce dominant drug resistance markers were usually first plated onto a YPD-plate, incubated over night at 30°C, and then replica plated onto the selective plate. The plates were incubated at 30°C until colonies were grown (~2 days for YPD agar plates, ~3-5 days for SD agar plates lacking the appropriate nutrients). A small portion of the colony was streaked onto 1/6 to 1/8 of an YPAc using an inoculating loop. The YPAc agar plate was incubated at 30°C for 2-3 days. YPAc agar plate was checked for growth and clones unable to grown on acetate were discarded. The clones which were able to grow on acetate were further processed for genotyping.

## 2.10 Spotting Assay

To measure the viability of yeast strains exposed to osmotic stress on plates, cells were grown to mid-exponential phase at 30°C. All cultures were adjusted to an OD<sub>600nm</sub> of 3.0. From this stock fresh tenfold serial dilution in culture medium was prepared. For each dilution 3-5 µl cell suspension were spotted onto YPD or synthetic dextrose (SD) plates containing the indicated concentrations of NaCl or D-sorbitol. After 2-4 d at 30°C growth was documented by photography on a Gel Doc 2000 system (Bio-Rad Laboratories, Hemel Hempstead, UK). In liquid culture osmotic stress was induced with 0.6 M NaCl or 1.2 M sorbitol for 20 min, if not noted otherwise, in cells grown to mid-log phase in YPD or SD medium lacking appropriate nutrients to maintain selection of plasmid-borne nutritional markers.

## 2.11 Chromatin Immunoprecipitation

50ml of cell culture (YPD or SD-Trp) was grown to an OD<sub>600</sub> of ~0.5-0.7 and the chromatin was crosslinked by addition of formaldehyde to a final concentration of 1% (w/v). Cells were slowly agitated for 15 min at room temperature before quenching of the remaining formaldehyde by addition of glycine to a final concentration of 125 mM (from a 2.5M stock solution). Cells were harvested by centrifugation (3,000 g, 4°C, 2 min) and resuspended in ice-cold CHIP lysis buffer. Cells were lysed with zirconium silica beads ( $\varnothing$  = 0.5 mm) in a Precellys 24 instrument (Bertin Technologies, Montigny-le-Bretonneux, France) using 2 cycles of a 30 s run at 6,500 rpm and a 30 s cooling break. Crosslinked chromatin was collected by centrifugation and sheared by sonication in a Bioruptor (Diagenode, Liège, Belgium) using 25 cycles of a 15 s run at high power setting and a 30 s cooling period. Preliminary experiments established that these conditions shear *S. cerevisiae* chromatin to an average size of 0.4 – 0.6 kbp. The sheared chromatin was cleared by centrifugation for 30 min at 12,000 g and 4°C. A portion of this chromatin preparation was set aside as 'input chromatin'. 50-400 µl sheared chromatin were precleared with 20 µl of a 25%

(w/v) slurry of protein A Agarose beads, depending on the antibody to be used, for 1 h at 4°C with overhead rotation. After pelleting of the agarose beads by centrifugation (30 s, 735 g, 4°C) the supernatant was transferred into a fresh 1.5 ml microcentrifuge tube and immunoprecipitated at 4°C overnight with overhead rotation using 4µg of the appropriate antibody. Chromatin immunoprecipitates were collected by addition of 20 µl of a 25% (w/v) protein A Agarose slurry and incubation for 2 h at 4°C. The sepharose beads were pelleted by centrifugation and washed successively for 4 minutes on an end-over-end rotator with 500 µl of the following solutions: twice with ChIP lysis buffer, once with deoxycholate buffer and once with 1 x TE (pH 8.0) at 4°C. To elute crosslinked chromatin from the sepharose beads, the beads were incubated for 10 min at 65°C in 50µl of Elution buffer, pelleted by centrifugation, and incubated a second time for 10 min at 65°C in the same volume of Elution buffer. After pooling of both eluates, 100 µl 1 x TE (pH 8.0) and 1 µl 20 µg/µl proteinase K in 50 mM Tris-HCl (pH 8.0) were added and the crosslinked chromatin was incubated for 2-3 h at 55°C, and then for 6 h at 65°C for reverse crosslinking. The DNA was extracted once with phenol/CHCl<sub>3</sub>/isoamylalcohol (25:24:1 v/v/v) and purified on a PCR purification column. The input chromatin was reverse crosslinked, extracted with phenol/CHCl<sub>3</sub>, ethanol precipitated and dissolved in 70 µl 1 x TE (pH 8.0). All ChIP experiments were repeated 2-3 times with independent samples. The averages and standard errors of these replicates are shown in all figures. ChIP results were normalized to input chromatin. ChIP results for acetylated H3 and H4 residues are presented as the ratio of the acetylated signal to the total H3 signal. ChIP results for HA-Hac1<sup>i</sup>, Sin3-MYC, Sds3-MYC and Gcn5-MYC are presented as the ratio of the signal normalized to input chromatin in cells expressing HA-Hac1<sup>i</sup> or MYC-tagged strains to the signal normalized to input chromatin obtained with the same anti-epitope antibody used on chromatin isolated from an untagged WT strain under the same growth conditions.

### 2.11.1 Quantitative PCR (qPCR) analysis of ChIPed DNA

Primers for qPCR are listed in Table 2.6

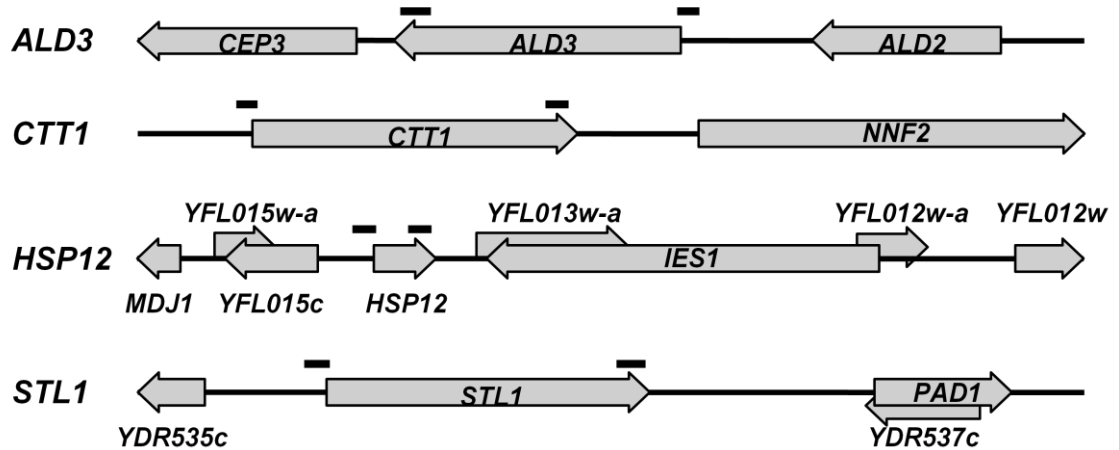

**Figure 2.1** Graphical depiction of the *ALD3*, *CTT1*, *HSP12*, and *STL1* loci indicating the location diagnostic PCR products in the promoters and 3' end of the ORFs that were used to analyze ChIPs.

qPCRs were run on a RotorGene 3000 thermocycler (Qiagen, Crawley, UK) using 2  $\mu$ l of immunoprecipitated DNA with 2  $\mu$ l of the corresponding 1:3 diluted input DNA. Amplicons were amplified with 0.5  $\mu$ l GoTaq DNA polymerase (5 U/ $\mu$ l), 2 mM MgCl<sub>2</sub>, 100  $\mu$ M dNTPs, and 1  $\mu$ M of each primer and detected with 1:2,500 fold dilution of a SybrGreen stock solution. After denaturation for 5 min at 95°C samples underwent 35 cycles of denaturation at 95°C for 30 s, primer annealing at 55°C for 30 s, and primer extension at 72°C for 30 s. Amplification of a single PCR product was confirmed by recording the melting curves after each PCR run. All amplification efficiencies were > 0.9. Calculation of  $C_T$  values and normalization of immunoprecipitated samples to corresponding input DNA was done with the RotorGene software. Each ChIP experiment was repeated 2-3 times with independent biological samples. All PCR reactions were repeated at least in duplicates to account for pipetting errors.



## 2.12 RNA isolation from yeast

**2.12.1 Reagents:** DEPC water, Ethanol (ice cold-100% and 70%), glass/silica beads, Formamide, phenol: CHCl<sub>3</sub>: isoamylalcohol (25:24:1 (v/v/v)), saturated with RNA buffer (only the bottom phase used).

**2.12.2 Protocol:** RNA was isolated from cells grown to an OD<sub>600</sub> of 0.4-0.6 and collected before and after osmotic shock treatment using 0.6M NaCl and 1.2M Sorbitol. Cells were collected by centrifugation for 2 min at 3000 rpm, 4°C. The supernatant was aspirated and the cells were resuspended in 1 ml ice-cold DEPC-H<sub>2</sub>O, and transferred into a 2.0 ml round or flat bottom screw-cap microcentrifuge tube. After centrifuging for 10 s in a microcentrifuge at 12,000 g, room temperature and pipetting out the supernatant and repeating this washing step with DEPC water, 300 µl RNA buffer was added to the washed pellets. The cell pellets were resuspended by vortexing and 200 µg acid-washed glass beads was added. 300 µl phenol:CHCl<sub>3</sub>:isoamylalcohol (25:24:1 (v/v/v)), saturated with RNA buffer was then added and the cells were lysed in a Precellys instrument at 4°C using two cycles of 10-15 s at 6,500 rpm with a break of 30 s between both cycles. After centrifuging at 13000G for 1min the upper phase was transferred to a new 1.5ml eppendorf tube and was once again extracted with 300 µl phenol:CHCl<sub>3</sub>:isoamylalcohol (25:24:1 (v/v/v)), saturated with RNA buffer. After centrifuging, the upper phase was transferred to a new 1.5ml eppendorf tube and RNA was ethanol precipitated. The RNA pellets were air dried and dissolved in 50-100µl of formamide and dissolved at room temperature for 1-2 hours. The RNA samples were stored in -80°C until used further for Northern blotting.

## 2.13 RNA agarose gel electrophoresis:

**2.13.1 Reagents:** DEPC water, DMSO, deionised glyoxal, 100 mM Na<sub>x</sub>H<sub>3-x</sub>PO<sub>4</sub> (pH 7.0), 10 mM Na<sub>x</sub>H<sub>3-x</sub>PO<sub>4</sub> (pH 7.0), RNA sample, 10 µg determined by UV spectroscopy and 6 x RNA sample loading buffer.

## **2.13.2 Protocol**

### **2.13.2.1 Gel preparation**

1.4%(w/v) of agarose is melted in an appropriate volume of 10 mM  $\text{Na}_x\text{H}_{3-x}\text{PO}_4$  (pH 7.0) in a baked Erlenmeyer flask. The flask is then placed in a 50°C water bath to equilibrate. Once the gel is poured and allowed to solidify then remove the combs and casting dams and immerse gel in 10 mM  $\text{Na}_x\text{H}_{3-x}\text{PO}_4$  (pH 7.0).

### **2.13.2.2 Sample preparation**

10 µg total RNA is denatured in a sterile 1.5 ml microcentrifuge tube by adding:

8.44 µl 6 M glyoxal, 25.00 µl DMSO, 5.00 µl 100 mM  $\text{Na}_x\text{H}_{3-x}\text{PO}_4$  (pH 7.0). The tubes are tightly closed, briefly vortexed, collected after a quick spin and incubated for 1h at 50°C. Once the samples are cooled after this incubation step, 10 µl of 6 x RNA sample loading buffer is added, mixed by vortexing, and droplets collected at the bottom of the tube by centrifugation for 10 s at 12,000 g, RT.

### **2.13.2.3 Electrophoresis**

The samples are loaded carefully onto the gel. Size standard is loaded on one side of the gel and one lane is left empty between the size standard and the samples. Electrophoresis is carried out at 3 V/cm electrode distance with constant buffer recirculation. Electrophoresis is continued till the bromophenol blue has migrated ~80% along the length of the gel.

### 2.13.2.4 Ethidium bromide staining of size standard

The lane with the size standard is cut off using a sterile razor blade. The sliced lane is placed into 0.5 M  $\text{NH}_4\text{OAc}$  + 0.5  $\mu\text{g/ml}$  ethidium bromide. Once incubated overnight with slow agitation protected from light, the marker is destained twice 20 min in type I laboratory water  $\text{H}_2\text{O}$  and photographed alongside a ruler. The remainder of the gel is ready for capillary transfer.

## 2.14 Capillary transfer of RNA

### 2.14.1 Protocol

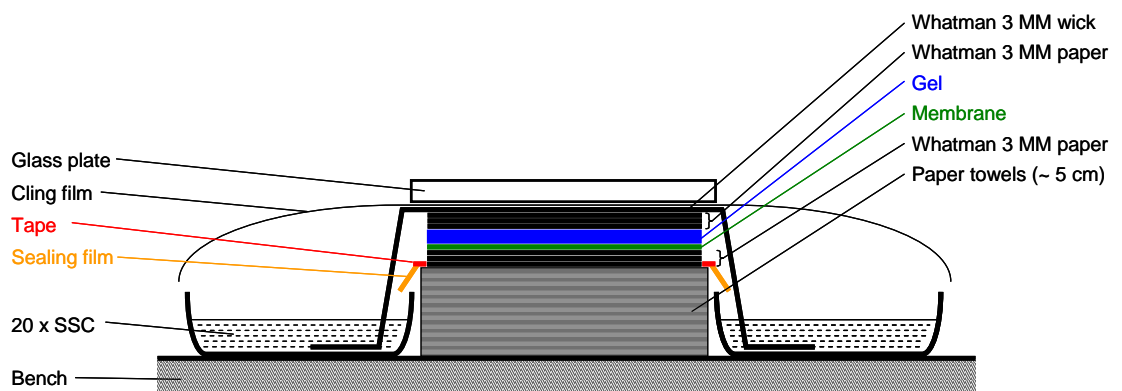

**Figure 2.2 Diagram representing capillary transfer of RNA**

A stack of paper towels about 5 cm high is made. As shown in the above Figure 2.1, four pieces of Whatman 3MM filter paper is placed on top of the paper towels. A fifth filter paper is soaked with 20 x SSC and place on top. The positive TM membrane is briefly wet in DEPC- $\text{H}_2\text{O}$  (Northern blot) and then transferred 20 x SSC. The membrane is then placed on top of the filter paper. Air bubbles are removed by rolling a pipet over the surface of the membrane. The gel is then carefully placed over the membrane and air bubbles removed. No part of the gel should extend over the edge of the membrane. Three pieces of Whatman 3MM paper cut to the same size as the gel, soaked with 20 x SSC and place on top of the gel. Once the air bubbles are removed by rolling the pipet, one larger piece of Whatman 3MM paper in 20 x SSC is placed over this assembly. This

piece of Whatman 3MM paper is large enough that it connected two trays with 20 x SSC on opposite sides of the stack. The sheet is placed on top of the stack and its ends into the trays with 20 x SSC. After removing air bubbles the stack and the trays is covered with cling film and a glass plate is placed on top of the stack. This assembly is left overnight. The transfer is then disassembled using forceps. The membrane is placed with the nucleic acid side up onto a piece of Whatman 3 MM paper. It is then immediately crosslinked to the nylon membrane at 120 mJ with UV light. The membrane is ready for hybridization with probe.

## 2.15 Hybridization of Northern blot

**2.15.1 Reagents:** Hybridization solution: 50% (v/v) formamide, 5 x SSC, 5 x Denhardt's solution, 1% (w/v) SDS, 100 µg/ml salmon sperm DNA (average size 2000 bp). [Recipe for 20 ml- In a 50 ml tube mix: Add 5 ml 20 x SSC, 2 ml 10% (w/v) SDS, and 1 ml 100 x Denhardt's solution. This mix is prewarmed at 42°C. In a second 50 ml tube 10 ml formamide is prewarmed to 42°C. Immediately before use 2 ml 1 mg/ml salmon sperm DNA is boiled for 5 min, then placed for 30 s on an ice-H<sub>2</sub>O bath. Denatured salmon sperm DNA is added to the aqueous premix and mixed. The aqueous premix and formamide is mixed and immediately added to the hybridization bottle containing the crosslinked blot. The blot is incubated with this prehybridization mix before it is hybridized with the probe. An equivalent mix is made for total volume of 5ml for the hybridizing mix.], Northern blot, 6 x SSC, 2 x SSC, 2 x SSC + 0.1% (w/v) SDS, 0.2 x SSC + 0.1% (w/v) SDS prewarmed to 42°C, 20 mM Tris·HCl (pH 8.0) prewarmed to 65°C

**2.15.2 Protocol:** The membrane is transferred into a hybridization bottle. More than one membrane can be added to the hybridization bottle but they must not overlap. The blot is then incubated for 15 min at 65°C in 20 mM Tris·HCl (pH 8.0). The membrane is wet in 6 x SSC and then prehybridized at 42°C with 20 ml hybridization solution/bottle for ≥ 3 h. The blot is then hybridized with 2 ng/ml <sup>32</sup>P-labeled DNA probe overnight at 42°C in a final volume of 5 ml/hybridization bottle [protocol for labelling

the probe is described below]. Denatured <sup>32</sup>P-labeled DNA probe is added to the hybridization solution at the same step as the denatured salmon sperm DNA solution. The blot is then washed 3 times for 5 minutes at room temperature with 200 ml 2 x SSC + 0.1% (w/v) SDS and then once for 5 min at RT with 200 ml 0.2 x SSC + 0.1% (w/v) SDS. The membrane is then transferred into a clean hybridization bottle and washed once for 15 min at 42°C with 50 ml 0.2 x SSC + 0.1% (w/v) SDS. The membrane is rinsed in 2 x SSC and excess liquid blotted off. The washed membrane is wrapped in cling film and expose to Kodak BioMax MS film at -80°C or room temperature in an exposure cassette fitted with intensifying screens for the desired time. The films are developed in dark room. Once films are developed the membrane is stripped and used again for hybridizing more DNA probes. The probes for *HAC1*, *KAR2*, *PDI1*, and the loading control pC4/2 were described previously (Schröder et al., 2003). Templates for probe synthesis for *HSP12*, *STL1*, *CTT1*, and *ALD3* were generated by PCR with the primer pairs shown in Table 2.6. All mRNAs were quantified by phosphorimaging on a Typhoon 9400 system (GE Healthcare). Measurements were normalized to the loading control and multiplied by 100 and are shown as 'normalized signal' below each band in figures. The percentage (%) cleavage of *HAC1* mRNA was calculated by the formula:

$$\% \text{ cleavage} = \frac{2 \cdot HAC1^i + \text{first exon\&intron} + 1.5 \cdot \text{first exon}}{2 \cdot (HAC1^u + HAC1^i + 1^{st} \text{exon\&intron} + 1^{st} \text{exon})}$$

All Northern blotting experiments were repeated two or three times.

## 2.16 Random Primed <sup>32</sup>P Labeling of DNA probes (Rediprime™II GE Healthcare)

**2.16.1 Reagents:** Hartmann Analytic or Perkin Elmer [ $\alpha$ -<sup>32</sup>P]-dCTP, 3000 Ci/mmol, ~10  $\mu$ Ci/ $\mu$ l, DNA probe 10-25 ng (must be diluted with TE buffer), TE Buffer, 0.2 M EDTA, Random Primed <sup>32</sup>P Labeling kit and microspin™ S-300 HR Column (GE Healthcare), Heat block at 100°C, Plexiglas box for 1.5 ml tubes, Waterbath at 37°C

**2.16.2 Protocol:** The DNA probe is diluted to a concentration of 2.5-25 ng in 45  $\mu$ l of 10 mM Tris HCl pH 8.0, 1 mM EDTA (TE buffer). The DNA probe is denatured by heating for 5 min at 95-100°C and placed on ice. The sample is then centrifuged to collect the whole content at the bottom of the tube. The DNA is then added to the reaction tube. The blue pellet is dissolved by repeatedly flipping the tube. The contents are centrifuged for 10 s at RT to collect the whole solution at the bottom of the tube. 5  $\mu$ l [ $\alpha$ -<sup>32</sup>P] dCTP is added and mixed by flipping the tube. The mix is then incubated at 37°C for 10 minutes. The reaction is stopped by adding 5  $\mu$ l of 0.2 M EDTA. During the incubation time, the column with resin is prepared. The resin is resuspended in a microspin S300 HR column by vortexing. The cap is loosened and the bottom closure is snapped off. The column is placed in a 1.5 ml screw-cap microcentrifuge tube for support. The column is pre-spun at 735 x g for 1 minute. The column is then placed into a new 1.5 ml tube and the incubated sample is slowly applied to the top-centre of the resin, and carefully so as to not disturb the bed. The tube is closed with the cap being not too tight and spun at 735 x g for 2 minutes. The purified sample is collected in the bottom of the support tube. For use in hybridization, the labelled DNA is denatured again by heating to 95-100°C for 5 minutes and then placed on ice. The tube is centrifuged briefly and the contents of the tube are mixed well. The probe is added to blot. For 5 ml hybridization solution, 10 ng of labelled probe is used (based on the input amount of DNA).

## 2.17 Stripping of Northern blots

**2.17.1 Reagents:** Stripping solution1-50% (v/v) formamide, 1% (w/v) SDS, 0.1 x SSC prewarmed to 65°C, Stripping solution2- 1% (w/v) SDS, 0.1 x SSC prewarmed to 65°C, Northern blot, 2 x SSC

**2.17.2 Protocol:** The membrane is transferred into a hybridization bottle. The membrane is then incubated with the stripping solution 1, twice for 30 min at 65°C and once in strip solution 2 for 10 min at 65°C. The membrane is rinsed in 2x SSC, wrapped in clip fling film and stored indefinitely at -20°C or can be used gain for rehybridization.

## CHAPTER 3

---

# UPR IS REQUIRED FOR SURVIVAL OF CELLS AGAINST HYPEROSMOTIC STRESS



The **Unfolded Protein Response** (UPR) is a signal transduction pathway between the nucleus and the cytoplasm to alleviate protein load on the ER. Ire1p, an endoribonucleokinase, and Hac1p, a basic leucine zipper transcription factor are critical components of the UPR. Another UPR component, the *RPD3* HDAC has been shown previously to interact with *HAC1* under nutritional stress (Schröder et al., 2004). The mechanism of how and if at all the UPR integrates with other pathways like osmotic, heat or anaerobic stresses is largely unknown. To understand how critical components of the UPR like Ire1p, Hac1p and Rpd3p responded to in an environment of hyperosmotic stress, Chapter 3 addressed the following questions-

1. Are UPR components like *IRE1* and *HAC1* required to protect cells against hyperosmotic stress?
2. Do the *RPD3* HDAC and *HAC1* interact together to provide resistance under acute osmotic shock?
3. Does hyperosmotic stress induce *HAC1* splicing?

### **3.1 *IRE1* and *HAC1* provide resistance against acute osmotic shock**

The UPR is a signalling pathway between the nucleus and ER to overcome protein folding defects within a cell. Key molecules which operate within the UPR protect cells from a protein overload on the ER and maintain protein homeostasis. One such key molecule is Ire1p, an endoribonucleokinase which splices the *HAC1* mRNA. Hac1p is pivotal to the UPR. It is a basic leucine zipper transcription factor. The primary metabolites for protein synthesis are obtained from the basic carbon and nitrogen components provided as nutrients and hence the UPR is strongly linked to nutritional stress in yeast. In the absence of nutrients, diploid yeast cells sporulate, a process during which yeast cells remain dormant until the environment is rich again in nutrients. In the presence of nutrients, Hac1<sup>i</sup>p negatively regulates expression of *EMGs*

(Schröder et al., 2004). This repression of *EMGs* requires the Rpd3p-Sin3p HDAC. Hence Hac1<sup>i</sup>p is a Rpd3L-dependent negative regulator of *EMGs* (Schröder et al., 2004). Ire1p, Hac1p and Rpd3p have been extensively studied under the UPR and nutritional stress signalling pathway in yeast but known mechanisms of how and if at all these molecules integrate within other stress signalling pathways has not been investigated yet.

The Rpd3p-Sin3p HDAC is known to repress genes but recent reports have suggested that it is involved in the transcriptional activation of certain sets of genes under a particular stress condition such as osmotic stress (de Nadal et al., 2004), heat stress (Mas et al., 2009; Ruiz-Roig et al., 2010) anaerobic stress (Sertil et al., 2007) and DNA damage (Sharma et al., 2007). These are genes for which Rpd3L is a direct, positive regulator and to which Rpd3L is recruited independent of Ume6, such as genes of the GSR (de Nadal et al., 2004; Ruiz-Roig et al., 2010). As it was previously shown that Hac1p interacted with the Rpd3p HDAC, this study hypothesized that Hac1<sup>i</sup> is a positive, Rpd3L-dependent regulator of GSR genes.

In order to identify whether components of the ER signalling pathway contributed in protecting cells under severe osmotic stress, this thesis commenced with the investigation of knowing whether deletion strains of *HAC1* or *IRE1*, components critical to the UPR pathway, sensitized yeast to hyperosmotic stress through growth assays (spotting assays). Using lower concentrations of osmolytes in previous studies demonstrated no changes in the growth phenotypes when compared to the corresponding WT strains. For example, it was previously reported that *ire1Δ* cells were not sensitive to 0.2 M NaCl (Torres-Quiroz et al., 2010). Hence the WT and UPR specific deletion strains used in Figure 3.1 for a spotting assay were first tested for sensitivity using higher concentrations of sorbitol as an osmotic agent.

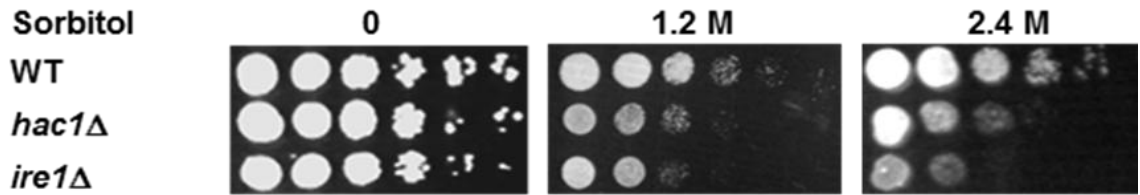

**Figure 3.1 The UPR is required for survival of hyperosmotic stress** Strains with a defective UPR are sensitive to osmotic stress. WT (MSY 138-17) and the corresponding isogenic *hac1Δ* (MSY 296-01) and *ire1Δ* (MSY 525-07) strains were grown on YPD plates, and YPD plates with 1.2 M or 2.4 M sorbitol, respectively. The plates were kept at 30°C and growth was scored after 1-2 days. The assay was repeated three times and showed similar results. The figure is a representative of one of the results.

Under normal growth conditions scored after two days, the WT, *ire1Δ* and *hac1Δ* strains had similar growth phenotypes. The *ire1Δ* and *hac1Δ* cells were sensitive to high concentrations of sorbitol when compared to the WT strain. For 1.2 M sorbitol treatment, the phenotypes of both the deletion strains were comparable to each other whereas the *ire1Δ* strain was more sensitive to 2.4 M sorbitol treatment than the *hac1Δ* strain. Data from Figure 3.1 suggested that components of the ER pathway had a protective role under hyperosmotic stress when subjected to high molar concentrations of osmotic agents like sorbitol. As it was observed that the *hac1Δ* strain was sensitive to hyperosmotic stress, a hypothesis was drawn stating that an overexpressing  $Hac1^i$  strain would provide resistance against hyperosmotic stress. To test this hypothesis, a strain overexpressing  $Hac1^i_p$ , derived from its own promoter in a single copy centromeric plasmid was subjected to osmotic shock. In addition, to rule out the possibility that the growth phenotypes observed for the *HAC1* deletion strain were specific to varying molar concentrations of sorbitol alone, NaCl with varying concentrations was used to test the WT and the  $Hac1^i$  overexpressing strains for their growth phenotypes.

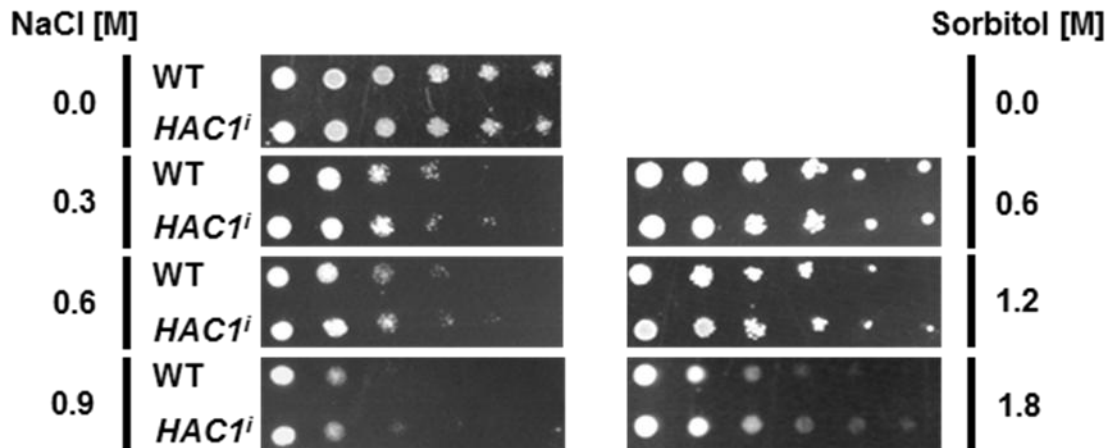
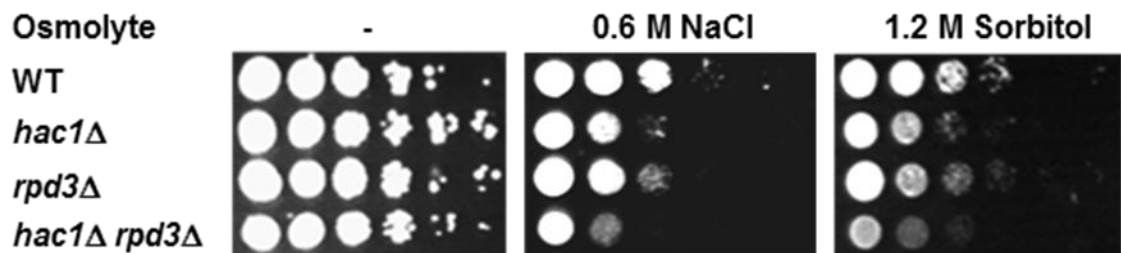

**Figure 3.2 Overexpression of *Hac1<sup>i</sup>* slightly enhances resistance to osmotic stress** WT (MSY 134-36) with an empty pRS314 vector and a strain having plasmid borne expression of *HAC1<sup>i</sup>* were spotted on SD-Trp agar plates with or without osmotic agents under different molar concentrations. The growth was recorded after 2-3 days after incubating cells at 30°C.

In the control SD-Trp plate having no osmotic agent (Figure 3.2) the growth phenotypes of the WT and *HAC1<sup>i</sup>* overexpressing strains were identical after 3 days. On exposure to varying concentrations of NaCl, the *HAC1<sup>i</sup>* overexpressing strain provided better resistance when compared to the phenotypes of the same strain with varying concentrations of sorbitol. Overall, the strain overexpressing *Hac1<sup>i</sup>* modestly improved growth under varying concentrations of NaCl and sorbitol when compared to the WT strain (Figure 3.2). Data from Figures 3.1 and 3.2 have shown that the UPR components *IRE1* and *HAC1* are linked to osmotic stress. Deletion of these two critical UPR components resulted in a growth sensitivity when exposed to high concentrations of sorbitol. Moreover a strain overexpressing *HAC1<sup>i</sup>* provided a sufficient level of resistance to cells under different concentrations of NaCl and sorbitol.

### 3.2 *HAC1* and *RPD3* provide hyperosmotic shock resistance

Another UPR component which in recent years has been well studied under osmotic stress is the Rpd3 HDAC. Hac1p has been previously shown to interact with the Rpd3p-Sin3p HDAC under nutritional stress (Schröder et al., 2004). To probe whether Hac1p acted through Rpd3p or independent of Rpd3p under hyperosmotic stress, spotting assays using a *HAC1* deletion strain, a *RPD3* deletion strain and a *HAC1* and *RPD3* double deletion strain was performed. Exposing *HAC1* or *RPD3* single deletion mutant strains to hyperosmotic shock environments would reveal whether or not these two molecules would be involved in protecting cells against acute osmotic shock. The growth phenotype of a *HAC1* and *RPD3* double deletion mutant strain in comparison to the individual deletion mutant strain phenotypes would reveal whether the two molecules act independent of one another or have masking effects (epistasis) on each other.



**Figure 3.3 *HAC1* and *RPD3* provide resistance against osmotic shock** WT (MSY 134-36), *hac1Δ* (MSY 211-02), *rpd3Δ* (MSY 287-01), and *hac1Δ rpd3Δ* (MSY 307-03) strains were spotted on YPD plates with or without stress as indicated. The growth was recorded after 2-3 days of incubation at 30°C.

A 0.6 M sorbitol concentration did not seem to have marked phenotypic effects on a *HAC1* over expressing strain (Figure 3.2). Therefore a more severe osmotic shock treatment of 0.6 M NaCl and 1.2 M sorbitol was tested to reveal growth defects of *rpd3Δ* and *hac1Δ* strains (Figure 3.3). Both the *HAC1* and *RPD3* single deletion strains were sensitive to 0.6 M NaCl and 1.2 M sorbitol when compared to the WT strain. The *hac1Δ* cells were slightly more sensitive to osmotic stress than *rpd3Δ* cells but the overall phenotypic effects of the single deletion mutant strains

suggested that *HAC1* and *RPD3* were involved in protecting cells during hyperosmotic shock. Combination of both deletion mutant strains resulted in a more severe growth defect under NaCl or sorbitol stress when compared to the individual deletion mutant strains.

The data in Figure 3.3 indicate that, while *HAC1* and *RPD3* individually provide protection to hyperosmotic shock they interacted independent of each other, as the additive effects of a *HAC1* and *RPD3* double deletion strain of both of these essential UPR components was more sensitive than the single deletion mutant stains.

### 3.3 Hyperosmotic stress induces *HAC1* splicing

Hac1p is a bZIP transcription factor and its splicing is critical to alleviate protein folding defects within the UPR. The *hac1Δ* strain was sensitive to osmotic agents while a strain overexpressing Hac1<sup>i</sup>p conferred resistance to hyperosmotic shock (Figures 3.1, 3.2 and 3.3). These data indicate that critical components of the UPR like *IRE1*, *HAC1* and *RPD3* were required to survive severe osmotic stress. Spliced *HAC1* is an important feature of the UPR pathway because after splicing, the functional *HAC1* mRNA is translated to generate the bZIP Hac1p. Moreover, a spliced *HAC1* mRNA is indicative of ER stress. The *HAC1* and *IRE1* requirement under osmotic stress suggested that *HAC1* splicing occurred when cells were under an osmotic shock. To investigate the hypothesis whether osmotic stress activated Ire1p and production of spliced Hac1<sup>i</sup>p, *HAC1* splicing was characterized in osmotically-stressed cells by Northern blotting. Figure 3.4 shows the results from this experiment. A 3.9% splicing of induced *HAC1* mRNA with 0.6 M NaCl and 7.3% splicing of induced *HAC1* mRNA with 1.2 M sorbitol was observed in osmotically-stressed cells which are an increase to the basal level *HAC1* splicing observed in unstressed cells (Figs. 3.4a and 3.4b). Osmotic stress also slightly but reproducibly induced expression of the ER chaperones *KAR2* and *PDI1*, which is consistent with production of Hac1<sup>i</sup> in osmotically-stressed cells. As observed previously, osmotic shock also induced expression of several GSR genes like *ALD3*, *HSP12* and

*CTT1*. Augmentation of *HAC1* splicing by activation of Ire1p with tunicamycin, which induces ER stress (Back et al., 2005), potentiated expression of several GSR genes, such as *ALD3* and *HSP12*.

The data presented in Figure 3.4 suggest that osmotic stress activates Ire1p to splice *HAC1*.

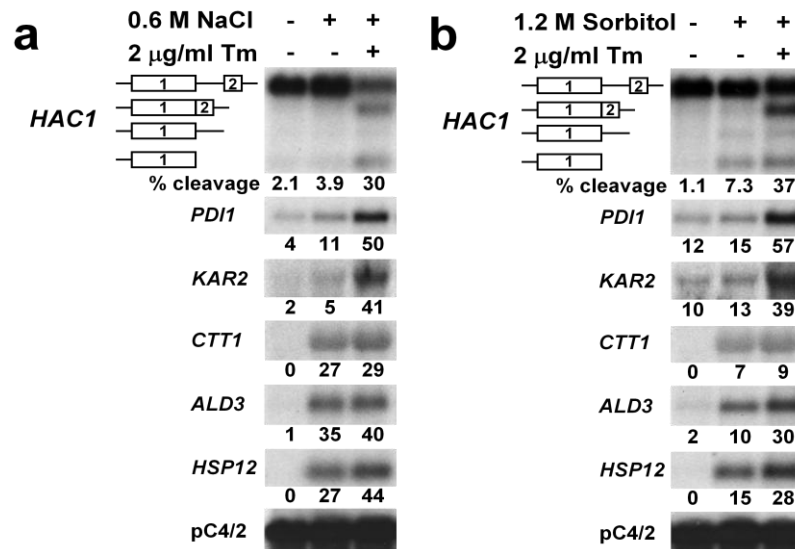
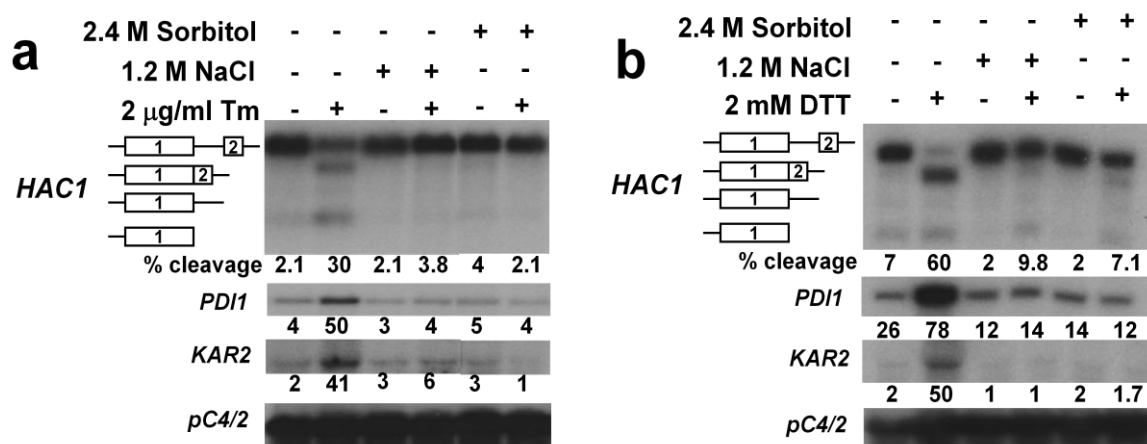

**Figure 3.4 Osmotic stress induces *HAC1* splicing** A WT (MSY 134-36) strain was grown in YPD medium until mid-log phase at 30°C. Total RNA was isolated from WT cells treated for 30 min with 0.6 M NaCl (a), 1.2 M sorbitol (b), or tunicamycin (Tm, with both NaCl and sorbitol) as indicated was analyzed by Northern blotting. The blots were probed for *HAC1*, classical UPR targets such as the chaperones *KAR2* and *PDI1*, and three GSR genes *CTT1*, *ALD3* and *HSP12*. *pC4/2* was probed as a loading control. The formula to calculate the percentage cleavage for *HAC1* signals is explained in Chapter 2. The method of generating numbers for quantitation of the gene induction levels is also explained in Chapter 2 and has been generated using the phosphoimaging screen images of the Northern blot. The Northern blotting experiment was repeated twice, giving identical results and the figure is a representative of one of the two biological independent experiments.

Data from figures in section 3.1 and 3.2 suggested that essential molecules associated with the UPR were also required to survive an osmotic shock. Hyperosmotic stress also induced *HAC1* splicing, as *HAC1* splicing was observed at 0.6 M NaCl and 1.2 M sorbitol (Figure 3.4). It is also known that induction of many genes after hyperosmotic shock peaks even after 45 minutes (early phase) of treatment with an osmotic agent (Rep et al., 2000). To investigate whether UPR offered a protective role at higher concentrations of osmotic agents, a Northern analysis was performed

to probe whether *HAC1* splicing occurred at higher molar concentrations of NaCl and sorbitol during this early phase of osmotic shock (Figure 3.5). Other than tunicamycin, DTT was also used as an ER stressing agent (Figure 3.5). DTT was used in order to test whether further increase in levels of *HAC1* splicing observed under osmotic stress and ER stress was not specific to tunicamycin treatment alone as observed in Figure 3.4. 1.2 M NaCl lowered *HAC1* cleavage levels (Figure 3.5a and 3.5b) when compared to Figure 3.4a where the percentage of *HAC1* cleavage was higher with 0.6 M NaCl treatment alone. In presence of 1.2 M NaCl and tunicamycin or 1.2 M NaCl and DTT (Figure 3.5a and Figure 3.5b) the *HAC1* splicing was slightly more than with 1.2 M NaCl alone. This effect was still mild when compared to the augmentation of *HAC1* splicing with 0.6 M NaCl and tunicamycin treatment (Figure 3.4a). Nearly similar *HAC1* splicing effects were recapitulated on treatment with 2.4 M sorbitol as with 1.2 M NaCl and the effect of 1.2 M sorbitol with an ER stressor (Figures 3.5). The *HAC1* induction levels intensified on treatment with 2.4 M sorbitol and DTT than with 2.4 M sorbitol alone (Figure 3.5b) while the level of *HAC1* splicing with 2.4 M sorbitol and tunicamycin was lowered when compared to the *HAC1* splicing levels with 2.4 M sorbitol treatment alone (Figure 3.5a). There was also a corresponding decrease in the induction levels of chaperones observed for the treatment with 2.4 M sorbitol and tunicamycin. A possible explanation for this diverging observation is discussed in the next section of this chapter. Moreover, the lower levels of *HAC1* cleavage is more pronounced for treatments of osmotic stress agents with Tm than with DTT. Data from Figure 3.5 indicated that higher concentrations of osmotic agents alone attenuated *HAC1* splicing and were also indicative of an illative translational arrest which is discussed in the next section.





**Figure 3.5 Higher concentrations of osmotic agents arrest *HAC1* splicing** (a) A WT (MSY 134-36) strain was grown in YPD medium until mid-log phase at 30°C. Total RNA was isolated from WT cells after 30 min treatment with 1.2 M NaCl, 2.4 M sorbitol, or Tm (with or without NaCl and sorbitol) as shown. 10 µg of total RNA was analysed by Northern blotting. (b) Same treatment as in (a) but with 2 mM DTT. 10 µg of total RNA were analyzed for Northern blotting. The blots were probed for *HAC1*, chaperones *KAR2* and *PDI1* and the loading control *pC4/2*.

### 3.4 Discussion

#### 3.4.1 The ER and osmotic stress are linked

The first aim of this PhD work was to find whether there is a link between the UPR and osmotic stress. Data from chapter 3 suggested that there is indeed a link between the ER and osmotic stress. The UPR is a well-studied conserved nuclear-cytoplasmic signal transduction pathway. The Ire1p and bZIP transcription factor Hac1p are molecules which have been well studied within the UPR. There are many reports linking the UPR and osmotic stress (Babour et al., 2010; Bicknell et al., 2010; Bonilla and Cunningham, 2003; Chen et al., 2005; Lamitina et al., 2006; Liu et al., 2007; Pal et al., 2007; Scrimale et al., 2008; Torres-Quiroz et al., 2010). Initial data from this study has shown that *HAC1* and *IRE1* are required for survival of severe osmotic stress (Figure 3.1 and 3.2). Many different yeast strain backgrounds have been tested for their growth sensitivities to osmotic shock (deNadal et al., 2004; Torres-Quiroz et al., 2010). The data from this thesis reported for the first time that SK-1 *S.cerevisiae* yeast background was sensitive to an osmotic agent like sorbitol.

This yeast strain background has previously been extensively studied under nutritional stress but not osmotic stress. The *ire1Δ* cells showed similar level of growth sensitivity to a *hac1Δ* at 1.2 M sorbitol but the *IRE1* deletion strain was more sensitive than a *HAC1* deletion strain at 2.4 M sorbitol (Figure 3.1). This suggested that *IRE1* acts upstream and independent of *HAC1* in providing resistance to osmotic stress. Conversely, an overexpressing *HAC1<sup>i</sup>* strain provided a moderate resistance to hyperosmotic shock (Figure 3.2). Lower concentrations of NaCl (0.3 M) and sorbitol (0.6 M) do not have a marked effect on the growth phenotype of a *HAC1<sup>i</sup>* overexpressing strain (Figure 3.2). This was in agreement with a previous published report where lower concentrations of osmotic agents like NaCl did not significantly affect the growth phenotypes of deletion strains of UPR components (Torres-Quiroz et al., 2010). Data in Figures 3.1 and 3.2 demonstrated that deletion of UPR specific components, the *IRE1* and *HAC1* deletion strains were sensitive to hyperosmotic stress. Of other UPR components, *RPD3* has been well studied under different stress responses including osmotic stress. *IRE1* and *HAC1* are intrinsically linked because the endoribonucleokinase Ire1p splices the *HAC1* precursor mRNA which eventually results in a functional *HAC1* mRNA, which is then translated into the Hac1p. *HAC1* interacts with *RPD3* downstream of *IRE1*. There is evidence for interaction between Hac1p and Rpd3p under nutritional stress response (Schröder et al., 2004) but their interaction in other stress response pathways is largely unknown. Data from Chapter 3 again demonstrated that *HAC1* and *RPD3* were both independently involved in conferring resistance to hyperosmotic stress (Figure 3.3). The growth defect observed in the *HAC1* and *RPD3* double deletion strain was an additive effect of the individual single deletion mutant strains (Figure 3.3). *HAC1* and *RPD3* acted independent of each other in conferring resistance to hyperosmotic stress. A more sensitive growth phenotype of a *HAC1* deletion strain when compared to the *RPD3* deletion strain (Figure 3.3) firstly suggested that *HAC1* has a protective role against hyperosmotic shock. Secondly, the *HAC1* deletion strain still might retain some partial Rpd3 activity. It has been shown earlier that deletion of *HAC1* does not lead to complete loss of Rpd3 function (Schröder et al., 2004). Thus,

these data were consistent with Hac1<sup>i</sup>p acting upstream of Rpd3p and partially independent of Rpd3p to confer resistance to osmotic stress.

### 3.4.2 Protective role of UPR in hyperosmotic stress

Deletion strains of critical UPR components were sensitive to hyperosmotic stress (Figures 3.1, 3.2 and 3.3). UPR is a pathway with a protective role to reduce protein folding defects within a cell. Biochemical knowledge and elegant genetic studies on the UPR in the past two decades have pinned down the splicing of *HAC1* molecule as a trademark physical occurrence during ER stress within a cell. Hence, there was a strong possibility that if components of UPR played a role to protect yeast cells from osmotic stress then *HAC1* splicing is critical in cells exposed to an osmotic shock environment. Data revealed that when cells were exposed to 0.6 M NaCl and 1.2 M sorbitol there is a moderate but reproducible level of *HAC1* splicing (Figure 3.4). The activation of UPR under acute osmotic shock hence could directly or indirectly affect the ability of a cell to protect itself from an environment of acute osmolyte imbalance.

Indirectly, the UPR might be activated because the ER is overloaded with a number of proteins, cytosolic or organelle specific which might be required to combat the severity of osmotic shock. For example, osmolytes require passage through the cell wall and the cell membrane. Hyperosmotic shock might result in weakening of the cell wall which then requires the cell to signal making proteins which strengthen the cell wall. Hyperosmotic stress induces expression of several genes encoding cell wall proteins (Rep et al., 2000). An increased osmotic shock is therefore correlative with increased cell wall damage and hence production of a large number of cell wall associated proteins. This increased protein load quite possibly result in an ER stress and hence the UPR activation. Thus in spite of how cells protects themselves by signalling the UPR under adverse osmotic shock environment, to attain cellular homeostasis the cell usually deploys to more than one route of saving itself. Thus cells with a defective UPR may perish due to additive

effects from more than one stress. Cells with a compromised UPR may be unable to effectively handle cell wall protein increase in secretory cargo, causing them to be sensitive to osmotic stress. In a more direct way to overcome hyperosmotic shock, the UPR activates the ER chaperones and the GSR genes.

### **3.4.3 *HAC1* induces ER chaperones during hyperosmotic stress**

*HAC1* splicing is linked to nutrient starvation in yeast (Schroder et al., 2004) and during osmotic stress (Figure 3.4a and b) by inducing expression of chaperones to minimise the protein folding defects in the ER. During hyperosmotic stress, the production of Hac1<sup>i</sup>p is critical for increased transcription of genes coding ER chaperones, *KAR2* and *PDI1*. Kar2p binds to secretory and transmembrane precursor proteins to prevent their misfolding (Normington et al., 1989; Rose et al., 1989). *KAR2* has a high basal expression level and is further induced during the UPR activation (Normington et al., 1989; Rose et al., 1989). *PDI1* encodes a protein disulfide isomerase, a multifunctional protein resident in the ER lumen which is essential for the formation of disulphide bonds in the secretory and cell surface proteins (Mizunaga et al., 1990; Farquhar et al., 1991; Noiva and Lennarz, 1992).

### **3.4.4 *HAC1* splicing attenuates at high osmolyte concentrations**

At 0.6 M NaCl and 1.2 M sorbitol treatments, these ER chaperones were induced to protect cells from hyperosmotic shock and their expression levels were potentiated in the presence of ER stressor and osmolytes (Figure 3.4). Surprisingly, the protective role of UPR was compromised under higher concentrations of hyperosmotic shock as 1.2 M NaCl and 2.4 M sorbitol treatments alone attenuated *HAC1* transcription (Figure 3.5) during the early phase of osmotic shock treatment. This weakening of the *HAC1* induction levels provided a corollary that higher

concentrations of osmotic agents affect Hac1p synthesis. There was a mild increase in *HAC1* splicing when the cells were exposed to 1.2 M NaCl or 2.4 M sorbitol with tunicamycin or DTT treatments. This mild increase of *HAC1* splicing with both ER and osmotic stressors was more evident for treatment with DTT than tunicamycin. Tunicamycin and DTT have often been used as ER stressors (Back et al., 2005; Li et al., 2011). Tunicamycin, a glucosamine containing antibiotic blocks the N-linked glycosylation of nascent proteins (Back et al., 2005). 1.2 M NaCl or 2.4 M sorbitol results in minimal level *HAC1* splicing (Figure 3.5a). A minimal level of *HAC1* splicing is indicative of the minimal level of functional *HAC1* mRNA production and thereby an arrest of Hac1p synthesis. A protein synthesis arrest results in an arrest of N-linked glycosylation of newly synthesised proteins and hence no UPR was induced with tunicamycin (Figure 3.5a). DTT, while being a strong reducing agent affecting disulfide bond formation during protein synthesis, also affects newly synthesised proteins (Jamsa et al., 1994; Kuo and Lampen, 1974) thereby acting partially independent of protein synthesis and induced the UPR. The 2.4 M sorbitol treatment resulted in a basal level of *HAC1* splicing (Figure 3.5a) but additive effects of two potent ER and osmotic stressors resulted in the inability of a cell to protect itself.

In this view, the Hac1<sup>i</sup> signal produced by the UPR carried value specific information, that is, information on the presence of cell wall damage or an osmotic imbalance. While increased secretory cargo load or high osmolyte concentrations were direct plausible candidates for activation of *HAC1* splicing in osmotically-stressed cells (Figure 3.5 a and b), osmotic stress may damage the ER by other mechanisms. Water loss in cells exposed to an osmotic shock leads to increased cytoplasmic ionic strength (Gaxiola et al., 1992), cell shrinkage, and invaginations of the plasma membrane (Morris et al., 1986). These changes may affect the ER or, more specifically, the cortical ER. Upregulation of GSR genes under hyperosmotic shock is another direct way through which cells cope with hyperosmotic shock.

### 3.4.5 Hac1p as a potential GSR gene activating transcription factor

Hyperosmotic stress induced *HAC1* splicing (Figure 3.4). Hyperosmotic stress also induced GSR gene expression as observed previously to minimise damage to cells in response to a hyperosmotic shock (Figure 3.4). If it is the same WT strain under hyperosmotic shock that induced GSR gene expression and *HAC1* splicing, the data in Figure 3.4 quite emphatically suggested that the Hac1 bZIP transcription factor could potentially be involved in activation of a subset of GSR genes to provide osmotic shock resistance.

Moreover, the GSR gene induction levels were enhanced in the presence of tunicamycin (Figure 3.4). Bicknell *et al.* (Bicknell et al., 2010) have reported that ER stress activates Hog1. To address the possibility that elevated GSR gene expression in cells exposed simultaneously to osmotic and ER stress (Figure 3.4a and b) was due to hyper-activation of Hog1, the activation of Hog1p was characterized by Western blotting (Figure 3.6- unpublished data, Dr Samantha Dainty). Like other known MAP kinases, Hog1 activation is mediated by dual phosphorylation of its T174-X-Y176 motif in its T-loop. The data in Figure 3.6 showed that on exposure to tunicamycin for 30 min or 3 hours the phosphorylation of the Hog1 was similar to unstressed cells. Moreover, the phosphorylation of the Hog1 T-loop was not increased in cells simultaneously exposed to osmotic stress and tunicamycin when compared to NaCl or sorbitol treatments alone.

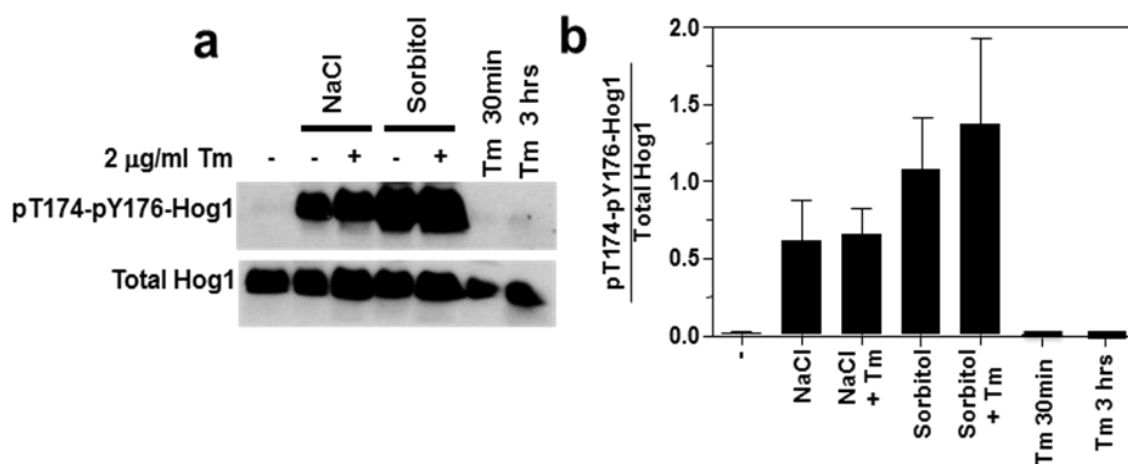

**Figure 3.6 ER stress does not augment Hog1p activation in osmotically-stressed cells** (a) Using a WT strain 9MSY 134-36), a representative Western blot for phosphorylation of the Hog1 T-loop is shown with or without NaCl and sorbitol treatments, in presence of absence of tunicamycin. In addition, tunicamycin treatment alone for 30 min and 3 hours is also shown. (b) Quantitation of the Western blot shown in panel (a). The signal for Hog1 T-loop phosphorylation was normalized to the signal for total Hog1. The average and standard error from three independent biological repeats are shown. Figure 3.6 is unpublished data from Dr Samantha Dainty.

During ER stress, a conserved pathway resulting in spliced *HAC1<sup>i</sup>* mRNA and activation of chaperone genes is a classic hallmark of the UPR pathway. The role of Hac1p in oxidative, heat and other stresses is yet unknown but evidence has been accumulating for its interacting HDAC partner, the Rpd3p HDAC as a key modulator of activating the GSR genes in response to various stresses. To investigate the role of Hac1p and Rpd3p, important interacting UPR components in hyperosmotic shock, chapter 4 indicates that these two key molecules interacted together to transcriptionally activate a subset of GSR genes.

## CHAPTER 4

---

# ***HAC1* AND *RPD3* TOGETHER ACTIVATE GSR GENES UNDER HYPEROSMOTIC STRESS**



Data from chapter 3 showed that UPR components provided protection against osmotic stress. Growth assays (Figure 3.3) showed that *HAC1* and *RPD3* were required during hyperosmotic stress. Moreover, a WT strain under hyperosmotic stress promoted *HAC1* splicing and also induced GSR genes (Figure 3.4) suggesting that UPR might be linked to GSR gene activation. In order to investigate if the UPR was involved in regulation of GSR gene expression, Chapter 4 provided answers to the following questions:

1. Is *HAC1* a positive regulator of GSR genes and if so is this effect of *HAC1* direct or indirect in regulating GSR genes?
2. Does *HAC1* require *RPD3* to activate GSR genes and if so through which Rpd3 complex, the small or the large complex, does *HAC1* act through, to promote GSR gene activation?
3. Does Hac1p epigenetically regulate GSR gene expression by affecting nucleosomal histone acetylation levels?

#### 4.1 Hac1<sup>i</sup>p is a positive regulator of GSR genes

*HAC1* requires *RPD3* to repress *EMGs* in *S. cerevisiae* (Schröder et al., 2004). Rpd3p is known to repress genes but recent reports suggest that this molecule is a transcriptional activator of the GSR genes in response to various environmental stresses (deNadal et al., 2004; Sertil et al., 2007; Mas et al., 2009; Ruiz-Roig et al., 2010). Rpd3p acts as a positive regulator of GSR gene activation and as data from Chapter 3 indicated that *HAC1* and the *RPD3* HDAC were required during hyperosmotic stress, thus a hypothesis was made that Hac1p with Rpd3p was also a positive regulator of GSR gene expression. For characterizing the role of Hac1<sup>i</sup> in transcriptional regulation of other Rpd3L-dependent genes, a pilot Northern blotting experiment using a WT SK-1 background yeast strain was performed first to optimise the duration of treatment and concentration of osmotic agents. The blot was then probed for a representative GSR gene, *HSP12* (Figure 4.1). Data from Figure 4.1 suggested that the optimum concentration of osmotic agents and optimum time for transcriptional activation for HSP12 for Northern blotting is 0.6M NaCl and

1.2M sorbitol treatments for 20 min (Figure 4.1). The concentration used for NaCl and sorbitol treatments and the time for osmotic shock for all further experiments was kept the same throughout the experimental work unless stated otherwise.

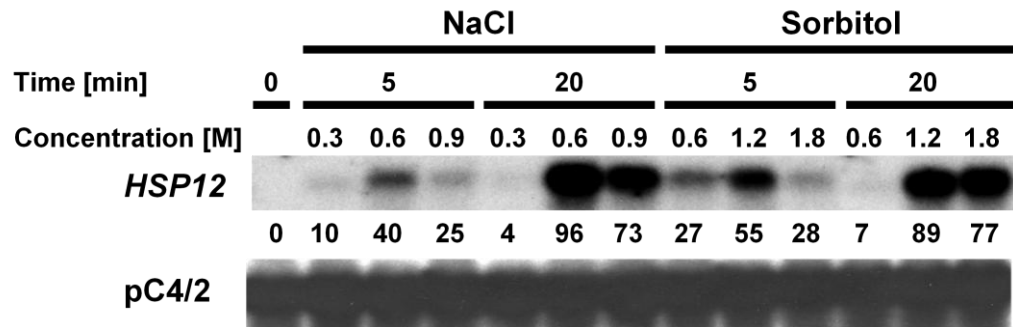
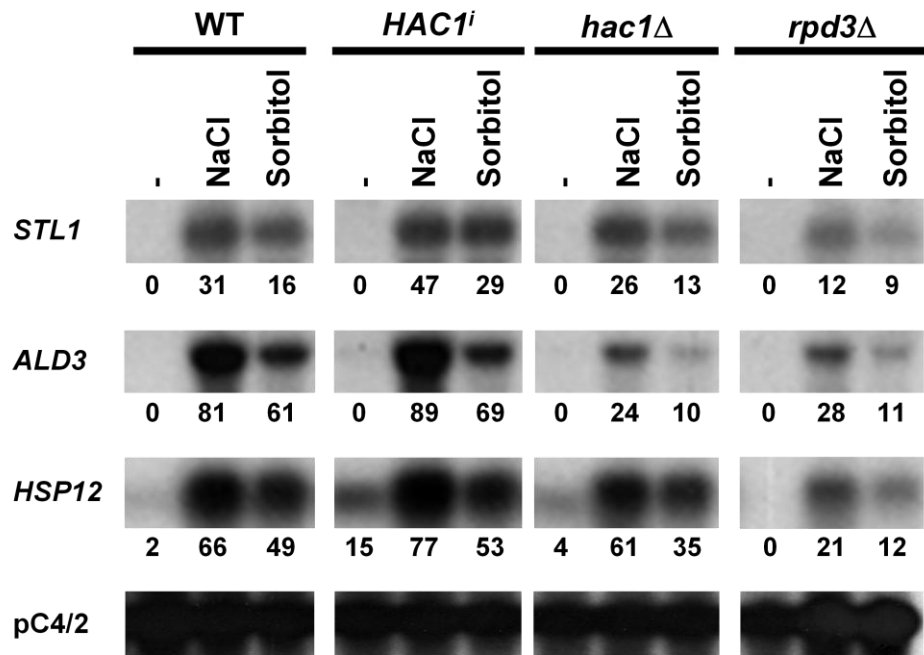

**Figure 4.1 Optimizing conditions for inducing GSR genes under osmotic stress** A pilot Northern blotting experiment was performed using a WT strain, where osmotic stress was induced for 5 or 20 min in a WT strain (MSY 134-36 + pRS314) with the indicated final concentrations of NaCl and sorbitol. 10  $\mu$ g total RNA was analyzed for expression of *HSP12* by Northern blotting. The numbers below the *HSP12* panel were values obtained after quantitation for the induction levels. Chapter 2 describes how these values have been generated. *pC4/2* was probed as the loading control.

Using optimum conditions this study elucidated the role of Hac1p in the transcriptional activation of the GSR genes under hyperosmotic stress. The osmotic stress transcriptional response was further characterised in WT, *hac1* $\Delta$  cells, Hac1<sup>i</sup> over-expressing cells and *rpd3* $\Delta$  cells (Figure 4.2).

When compared to the WT strain, the Hac1<sup>i</sup>p over-expression potentiated induction levels of three GSR genes *STL1*, *ALD3* and *HSP12* while deletion of *HAC1* interfered with the activation of these three genes (Figure 4.2). As observed in previous reports, deletion of *RPD3* markedly interfered with the expression levels of GSR genes under osmotic stress. Data from Figure 4.2 showed that *HAC1* was a positive regulator of GSR gene activation as the GSR gene induction levels were proportional to the *HAC1* overexpressing or *HAC1* deletion strains. Hence there was an increase in the induction levels of GSR genes in a *HAC1* overexpressing strain while the *HAC1*

deletion strain resulted in lower expression levels of GSR genes. The evidence presented in Figure 4.2 correlated with the growth phenotypes observed for the same strains in Chapter 3 (Figures 3.1 and Figure 3.2). In summary, these data suggested that Hac1p has a positive role in transcriptional regulation of GSR genes.

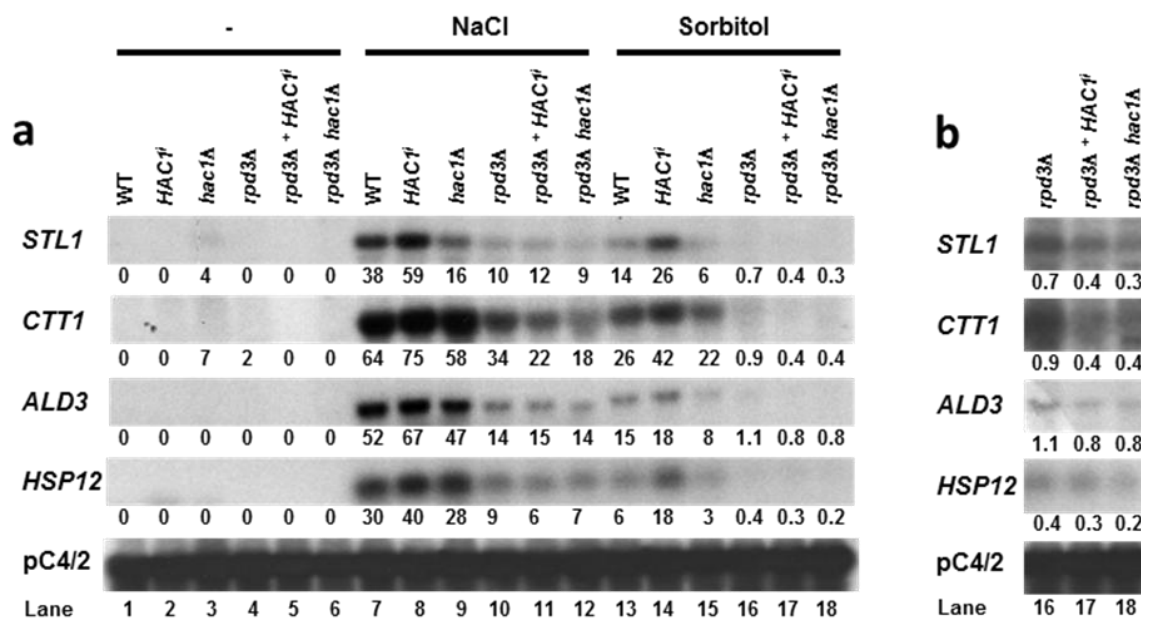

**Figure 4.2 Hac1<sup>i</sup> potentiates transcription of GSR genes during osmotic stress** Northern analysis of expression of *STL1*, *ALD3*, and *HSP12* in a WT (MSY 134-36) strain transformed with pRS314 or pRS314-*HAC1<sup>i</sup>*, a *hac1Δ* (MSY 211-02), and *rpd3Δ* (MSY 291-01) strain transformed with pRS314. The cells were grown in SD-Trp media until the mid-log phase at 30°C. The cells were then treated with or without 0.6 M NaCl or 1.2 M sorbitol for 20 min. The RNA was isolated and 10 μg was loaded on the gel for each sample. The blot was then probed for the three GSR genes mentioned above. The quantitation is shown below each panel of induction level of GSR genes. pC4/2 was probed as the loading control. The figure is representative of two independent biological repeats of the experiment with similar outcomes. All the lanes in Figure 4.2 were taken from the same blot and were hybridized to the same probes.

## 4.2 *Hac1<sup>i</sup>* acts through Rpd3L to potentiate transcription of GSR genes.

It is known that Hac1p interacts with the Rpd3L HDAC and requires the Rpd3p enzyme complex to repress *EMGs* (Schröder et al., 2004). Epistatic analysis of *HAC1* and *RPD3* in Chapter 3 (Figure 3.3) showed that these two molecules acted independent of each other to confer resistance to hyperosmotic shock. The growth assay in Figure 3.3 revealed phenotypic outcomes of *HAC1* and *RPD3* during hyperosmotic stress but the results do not indicate how these two molecules together regulated gene expression levels, like those of a subset of genes under GSR regulation. Figure 4.2 provided evidence that Hac1p was a positive regulator of GSR genes during hyperosmotic stress. Recent reports have also shown that Rpd3L is a positive regulator of GSR gene expression (de Nadal et al., 2004; Ruiz-Roig et al., 2010). Hence a hypothesis was laid that *HAC1* and *RPD3* interacted epistatically to regulate GSR gene expression under hyperosmotic stress. A Northern blotting experiment shown in Figure 4.3 was used to address this hypothesis. The WT strain, overexpressing *HAC1<sup>i</sup>* strain and the *HAC1* deletion strain recapitulated the same effects as observed in Figure 4.2. The strain overexpressing *HAC1<sup>i</sup>* on exposure to 0.6 M NaCl and 1.2 M sorbitol for 20 min had enhanced expression levels of the GSR genes while the *HAC1* deletion strain had lower induction levels when compared to the WT strain (Figure 4.3a). Quantitation of induction levels on the Northern blot (Figure 4.3a) confirmed the increase or decrease in induction levels in cells overexpressing Hac1<sup>i</sup>p or deleted for *HAC1*, respectively. In addition, the sorbitol and NaCl treatments in Figure 4.3a more clearly detailed the GSR gene expression effects than the gene expression effects observed in Figure 4.2. Deletion of *RPD3* markedly interfered with activation of several GSR genes by osmotic stress, as reported previously (de Nadal et al., 2004). The transcriptional effects of *HAC1<sup>i</sup>* manipulations for *STL1*, *CTT1*, *ALD3* and *HSP12* in an otherwise WT strain were stronger than in the corresponding *RPD3* deletion strains. The deletion of *RPD3* in a *HAC1* overexpressing strain or a *HAC1* deletion strain lowered the transcriptional signals in these double mutant strains when compared to the individual *HAC1*

mutant strains. This trend was observed for both, the 0.6 M NaCl and the 1.2 M sorbitol treatments though the induction levels in lanes 16-18 were weak in Figure 4.3a for the 1.2M sorbitol treatment. A longer exposure level revealed the signals in Figure 4.3b for lanes 16-18 from Figure 4.3a. Moreover, Figure 4.3a showed that *RPD3* interacted epistatically with *HAC1* as loss of *RPD3* masked the effects of over-expression of *Hac1*<sup>i</sup> or deletion of *HAC1* on induction of several GSR genes under 0.6 M NaCl or 1.2 M sorbitol treatments for 20 min (Figure 4.3a, compare lanes 11 and 12 with lanes 8 and 9 for 0.6M NaCl treatment and likewise lanes 17 and 18 with lanes 14 and 15 respectively for 1.2M sorbitol treatment). Overall, Figure 4.3a presented evidence that *Hac1*p acted as a positive regulator of GSR gene expression as also observed in Figure 4.2, and required the *Rpd3* HDAC for GSR gene activation.



**Figure 4.3 *Hac1*<sup>i</sup> acts through *Rpd3L* to potentiate transcription of GSR genes** (a) Cells were grown in SD-Trp media to mid-log phase at 30°C and osmotic stress was induced in WT cells transformed with empty vector (pRS314), a *Hac1*<sup>i</sup> overexpressing plasmid (pRS314-*HAC1*<sup>i</sup>), *hac1Δ* cells, *rpd3Δ* cells transformed with pRS314 or pRS314-*HAC1*<sup>i</sup> and *rpd3Δ hac1Δ* cells using 0.6 M NaCl or 1.2 M sorbitol for 20 min. RNA was isolated and 10 μg RNA for each sample were loaded on the gel. The blot was probed for the four GSR genes *STL1*, *CTT1*, *ALD3* and *HSP12*. *pC4/2* was the loading control. Quantitation of induction levels is represented as numbers below each image panel. The experiment has been repeated twice with similar outcomes. (b) A longer exposure of lanes 16-18 of Figure 4.3a.

Data presented in Chapter 4 until Figure 4.3 elucidated how *HAC1* and *RPD3* together regulated the GSR gene activation under hyperosmotic shock. In Figures 4.2 and 4.3a, the effects of *HAC1* manipulations on GSR gene regulation suggested Hac1p has a positive role in activating GSR genes. To investigate whether the effect of Hac1<sup>i</sup>p on expression of GSR genes is direct under hyperosmotic stress, Hac1<sup>i</sup>p carrying an N-terminal HA-tag was ChIPed to the promoters of four GSR genes (Figure 4.4). The results for the HA-Hac1<sup>i</sup> enrichment shown in the ChIP experiment were relative to the untagged WT strain. As seen in Figure 4.4, Hac1<sup>i</sup>p occupied GSR gene promoters in osmotically-stressed, but not in unstressed cells. The data also suggested that *HAC1* does interact with *RPD3* during hyperosmotic stress. Deletion of *RPD3* markedly affected the HA-Hac1<sup>i</sup> enrichment levels at the GSR gene promoter regions suggesting that presence of Hac1<sup>i</sup> on GSR promoters strictly required *RPD3* (Figure 4.4). Data from Figure 4.4 corroborated with previous findings in Chapter 3 and Figure 4.3 that not only were *RPD3* and *HAC1* linked together under hyperosmotic stress but that the requirement of *RPD3* was essential for *HAC1* to have a positive role during osmosensitive gene regulation.

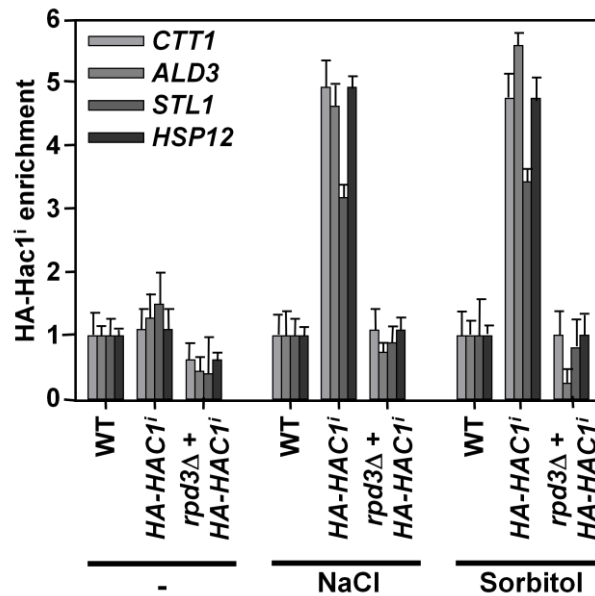
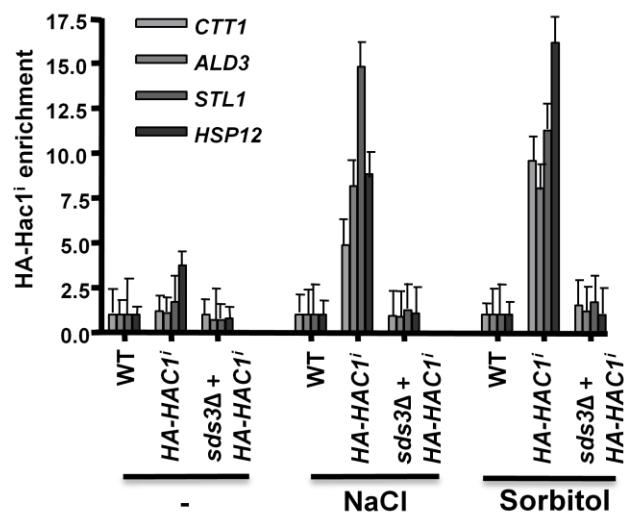

**Figure 4.4 Hac1p binds to GSR gene promoters** Cells were grown to mid-log phase in SD-Trp media at 30°C. For ChIP of HA-Hac1<sup>i</sup> to GSR promoters in a WT strain transformed with pRS314 or pRS314-*HAC1<sup>i</sup>*, and a *rpd3Δ* strain transformed with pRS314-*HAC1<sup>i</sup>*, the cells were then treated with or without 0.6 M NaCl and 1.2 M sorbitol for 20 min and crosslinked with 1% (w/v) formaldehyde. The ChIP protocol was performed as described in Chapter 2. The immunoprecipitated DNA was analysed using real time PCR. The RotorGene 3000 software was used to quantify the results and further analysis was calculated using Microsoft Excel. The average of three independent experimental values with error bars is represented in the figure.

Hac1p and Rpd3p-Sin3p HDAC interacted together during hyperosmotic stress to regulate GSR gene expression (Figures 4.2 and 4.3). Figure 4.4 elucidated that Hac1p may have a direct effect on GSR gene activation. In addition, Hac1p recruitment to GSR gene promoters was Rpd3p dependent as deletion of *RPD3* in a strain constitutively overexpressing Hac1<sup>i</sup> markedly affected HA-Hac1<sup>i</sup>p binding to GSR promoters (Figure 4.4).

Rpd3p is a common subunit for two Rpd3 HDAC complexes known in yeast, the Rpd3 large (L) complex and the Rpd3 small (S) complex. Both complexes have Rpd3p, Sin3p, and Ume1p common to them and several complex-specific subunits. Of these, Rco1p and Eaf3p are specific to Rpd3S, whereas Sds3p and Sap30p are examples for Rpd3L specific subunits. The Rpd3L promoter bound complex is known to activate or repress genes while the Rpd3S is known to suppress

cryptic transcription initiation (Carrozza et al., 2005; Keogh et al., 2005). The interaction of Hac1p with Rpd3L was shown earlier under nutritional stress (Schröder et al., 2004). To investigate whether it was the Rpd3L complex and not the Rpd3S complex that interacted with Hac1p on the GSR promoters, a similar ChIP experiment was performed as in Figure 4.4 using a *SDS3* deletion mutant instead of a *RPD3* deletion strain. Sds3p is a subunit specific to the large complex and also critical in keeping the Rpd3L complex intact. Again, the enrichment levels for the ChIP experiment was expressed as ratio of the tagged to the untagged WT strain. As observed in Figure 4.5, Hac1p was recruited to the promoters of GSR genes after osmotic shock with 0.6 M NaCl and 1.2 M sorbitol, as also observed in Figure 4.4. In addition, Hac1p does not show an increase in enrichment levels in the *SDS3* deletion strain (Figure 4.5). Data from the ChIP experiment in Figure 4.5 showed that it was the Rpd3L complex that interacted with Hac1p.



**Figure 4.5 Hac1p interacts with Rpd3pL complex to regulate GSR genes** A similar ChIP experiment as in Figure 4.4, where HA-Hac1<sup>i</sup> is ChIPed to GSR promoters in a WT strain transformed with pRS314 or pRS314-HAC1<sup>i</sup>, and a *sds3Δ* strain transformed with pRS314-HAC1<sup>i</sup>. The average of two independent experiments with standard errors is shown in the figure.



### 4.3 Hac1p does not affect nucleosomal histone acetylation pattern for GSR gene activation

*RPD3* was shown earlier to be a positive transcriptional regulator of GSR genes (de Nadal et al., 2004; Ruiz-Roig et al., 2010). Histone deacetylation in GSR promoters by the Rpd3p-Sin3p HDAC has been reported to mediate the GSR gene activation (de Nadal et al., 2004). One of the known substrates for the Rpd3 HDAC enzyme is the lysine residues on the N-terminal tails of the core histone proteins (Roth et al., 2001; Kuo and Allis, 1998). This study has shown that Hac1<sup>i</sup>p was also a positive regulator of GSR gene expression (Figure 4.2). The deacetylation of promoter nucleosomes by Rpd3p was earlier shown to activate GSR genes (de Nadal et al., 2004). Hac1p acted through Rpd3p (Figure 4.3a) and was a Rpd3p-dependent activator of GSR genes (Figure 4.2), and hence it was hypothesised that Hac1<sup>i</sup> potentiated deacetylation of GSR promoter nucleosomes. The hypothesis was tested using ChIP, where the effects of over-expression of Hac1<sup>i</sup>p and deletion of *HAC1* on acetylation of histone H3 lysine 9 (K9), H3 K18 and histone H4 K8 in the promoters of *ALD3*, *CTT1*, *HSP12*, and *STL1* were characterized (Fig. 4.6). These three lysine residues were chosen for the study because they exhibited the most favourable acetylation patterns for Hac1p among all the residues studied under nutritional stress (Dr Claire Bertrand, unpublished data). The acetylation signals were standardized to total histone H3 promoter occupancy. The WT strain exhibited an increase in acetylation after osmotic stress at the four gene promoter regions for the three residues. This increase of acetylation level for the WT strain correlated with the gene expression data in Figure 4.3a, where the WT strain showed elevated induction levels after treatment with 0.6 M NaCl or 1.2 M sorbitol. The manipulation of Hac1<sup>i</sup> levels, on the contrary, had no effect on the three acetylation sites (Fig 4.6a-c) as the acetylation levels for the *HAC1* overexpressing strain and the *HAC1* deletion strain were comparable to the acetylation levels in the WT strain.

Hyperosmotic stress, increased acetylation of H3 K9, H3 K18 and H4 K8 and, consistent with an earlier report (Mas et al., 2009), decreased H3 promoter occupancy (Fig. 4.6d). The decrease in nucleosomal histone density at the GSR promoters in Figure 4.6d was correlative with the increase in histone acetylation as observed for the three acetylation sites.

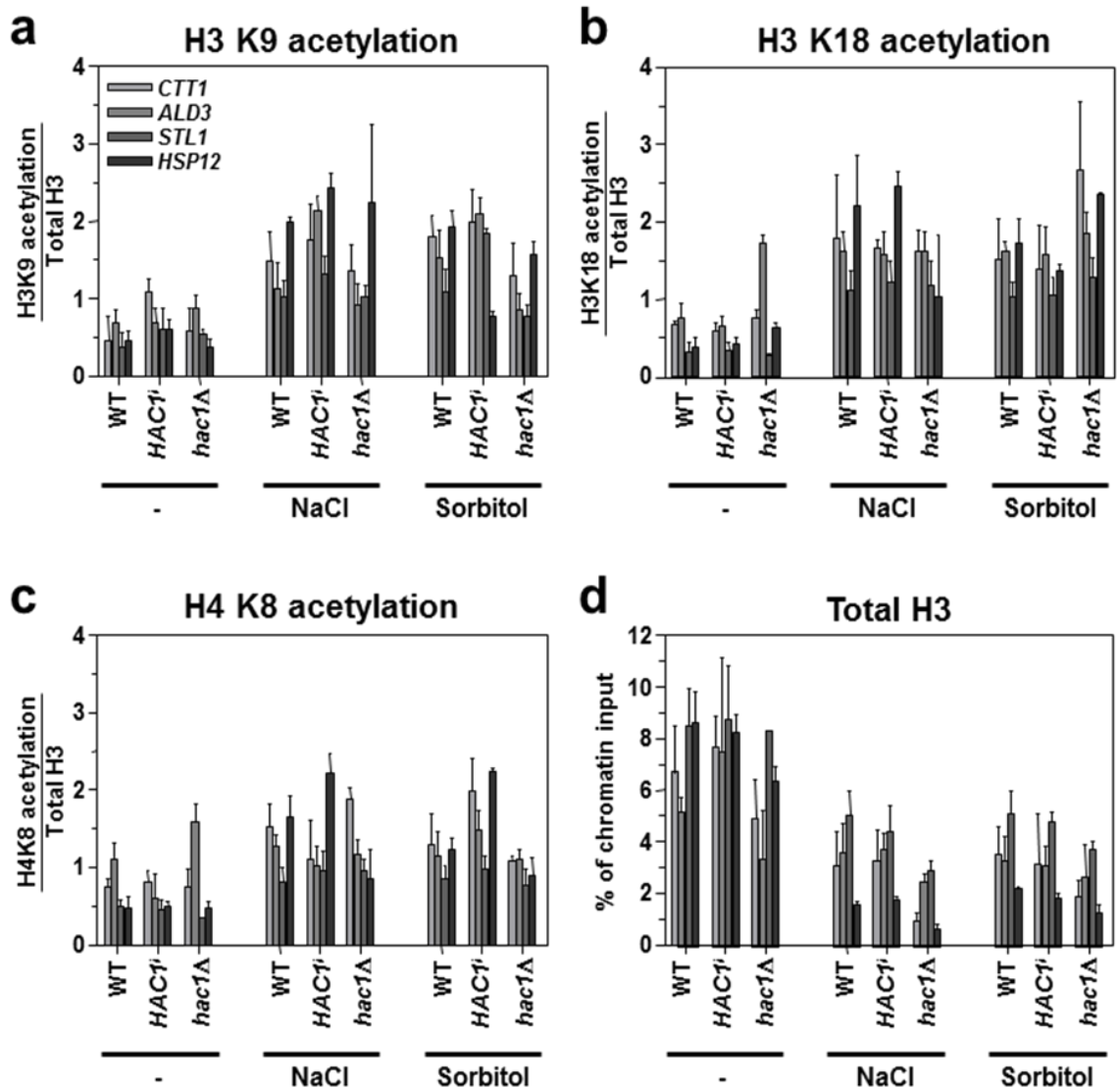

**Figure 4.6 Osmotic stress induces promoter nucleosome acetylation and nucleosome loss in GSR promoters** (a-c) Nucleosome acetylation in the promoters of *ALD3*, *CTT1*, *HSP12*, and *STL1* for the indicated acetylation sites before and after 0.6 M NaCl or 1.2 M sorbitol treatment in WT cells transformed with pRS314 or pRS314-*HAC1<sup>i</sup>* and *hac1Δ* cells. (d) Total histone H3 density measured by ChIP in the promoters of the genes and strains in panels (a-c). The cells were grown in SD- Trp medium until mid-log phase at 30°C. The cells were treated with 0.6 M NaCl or 1.2 M sorbitol for 20 min and crosslinked with 1% (w/v) formaldehyde. The ChIP protocol described in Chapter 2 was followed and the analysis was done using the RotorGene 3000 software and Microsoft Excel. The average of two independent biological repeats with standard errors is represented in the figure.

## 4.4 Discussion

### 4.4.1 The UPR and GSR gene regulation are connected

Chapter 4 demonstrated how the UPR components extend their role beyond the ER stress response realm to activate GSR genes under hyperosmotic shock. The role of *HAC1* in other stress responses has not been studied before. This study, for the first time showed that *HAC1*, an important component of the UPR pathway protected cells from hyperosmotic shock through growth assays in Chapter 3 (Figure 3.1 and Figure 3.2). The growth phenotypes for *HAC1* mutant strains indeed suggested that the molecule was a candidate factor involved in activation of genes which protected cells from hyperosmotic shock, like the GSR genes. Data in chapter 4 have demonstrated that the bZIP transcription factor Hac1, is involved in the transcriptional regulation of GSR genes. Activation of the GSR genes by Hac1p required the Rpd3L HDAC.

### 4.4.2 0.6 M NaCl and 1.2 M sorbitol for 20 min is optimal for inducing GSR genes

Previous reports have shown in various yeast strain backgrounds that time for induction of the GSR genes varies between 5-20 minutes (Alepez et al., 2003; deNadal et al., 2004). The results observed in Figure 4.1 were in agreement with previous published reports. For inducing GSR genes, in the SK-1 genetic background of *S. cerevisiae*, the optimum concentrations of NaCl and sorbitol were 0.6 M and 1.2 M respectively, (Figure 4.1). GSR genes were also induced in a WT strain after five minute treatment of 0.6 M NaCl and 1.2 M sorbitol (Figure 4.1). The 20 minute time point provided a better intensity of induction level at the same concentrations of osmotic agents and hence was used as the optimal condition of treatment for all further experiments.

#### 4.4.3 *HAC1* regulates a subset of GSR genes under hyperosmotic shock

Evidence generated in Chapter 4 indicated that central molecules of the ER stress pathway were interlinked to hyperosmotic stress at the molecular level. In the hierarchy of molecular steps which free DNA from its condensed chromatin state, transcription is a lot downstream. At the transcription level, Hac1p acted as a positive regulator to enhance expression of the GSR genes (Figure 4.2).

During hyperosmotic stress Hac1<sup>i</sup>, a sequence-specific bZIP transcription factor, whose synthesis is controlled by the UPR (Cox and Walter, 1996; Kawahara et al., 1997), was directed to GSR gene promoters to potentiate their expression (Fig. 4.2). The role of *HAC1* in hyperosmotic stress was determined in Figure 4.2 using the aforementioned treatment conditions. An over-expressing Hac1<sup>i</sup> strain facilitated the expression of GSR genes while cells having a *HAC1* deletion showed lower induction levels of GSR genes when compared to the WT strain (Figure 4.2). The Northern blotting data in Figure 4.2, indicated that a transcription factor specific to the UPR behaved as a positive regulator during transcription of GSR genes. There are several other transcription factors which operate on a subset of genes under hyperosmotic stress. Deletion of a specific transcription factor has a very limited effect on osmosensitive gene regulation as each transcription factor controls a small subset of osmoresponsive genes. For example, Hot1 is a transcription factor known to regulate a small set of osmoresponsive genes (Alepuz et al., 2003). Hot1, a transcriptional activator is specific in its binding to *STL1* whereas Msn2/Msn4 is specific to *ALD3* (Alepuz et al., 2001). Data showed that *HAC1* not only positively regulated expression of *ALD3* and *STL1* but also *HSP12* and *CTT1* (Figure 4.2). Under acute osmotic shock, the transcriptional defect of *HAC1* manipulations was not as strong as the effect of an *RPD3* deletion strain but the *HAC1* effects were reproducible. Data suggested that the UPR specific transcription factor Hac1p behaved as a positive regulator to activate a subset of osmoresponsive genes under hyperosmotic shock. The full extent of how Hac1p influences different gene sets under various stress responses

will have to be further undertaken through studies involving a genome wide analysis or ChIP sequencing experiments.

#### **4.4.4 Does MAP kinase Hog1 affect the positive role of *HAC1* in GSR gene regulation?**

In yeast, several transcription factors (Msn1, Msn2, Msn4, Hot1, Sko1 and Smp1) under hyperosmotic stress have been suggested to act downstream of the MAP kinase Hog1 (Alepez et al., 2003). Two different mechanisms of how Hog1 can regulate activity of a transcription factor have been proposed. One mechanism involves the MEF2-like transcription factor Smp1 (de Nadal et al., 2003) and the other involving the Sko1 transcription factor (Proft et al., 2001). It is likely that the positive role of Hac1p in activating GSR genes might be linked to Hog1p via a similar mechanism. Data from Figure 4.4 showed that the levels of HA-Hac1<sup>i</sup>p increased after hyperosmotic shock whereas the levels of HA-Hac1<sup>i</sup>p remained unaltered in unstressed cells. This observation might be attributed to an effect of the bZIP transcription factor acting downstream and being phosphorylated by Hog1 MAPK. This notion is supported by a possible link between the mammalian UPR and PMK-1 p38 MAPK pathway in mediating resistance to microbial pathogens (Richardson et al., 2010).

Bicknell and colleagues (Bicknell et al., 2010) recently suggested that that Hog1p is required during the late phase of ER stress response. However, Dr Dainty's unpublished data in Chapter 3 (Figure 3.6) demonstrated that the Hog1p activity increased on exposure to 0.6 M NaCl or 1.2 M sorbitol, which was as expected. The Hog1p activity remained largely unaltered and comparable to acute osmotic shock levels, in presence of both ER stress and osmotic stress (Figure 3.6). Moreover, in presence of tunicamycin alone for 30 min and 3 hours, the level of Hog1p phosphorylation was comparable to untreated cells. Data in Figure 3.6 suggested that while Hog1p activity was required when cells were under hyperosmotic shock alone, in presence of an ER stressor and osmotic shock the Hog1p activity does not increase. Another recent report also

suggested that the *HOG1* deletion strain, in spite of having sensitivity to ER stressing agents might not be involved in the regulation of the UPR (Torrez-Quiroz et al., 2010) as *HAC1* splicing was observed in a *HOG1* deletion strain (Torrez-Quiroz et al., 2010). Whether Hog1 affects the UPR components and whether it contributes to the positive role of *HAC1* in activating GSR genes is subject to further experimental investigation.

#### 4.4.5 Hac1p acts through Rpd3L to regulate GSR gene expression

Rpd3p has also been extensively studied under various stress pathways. Recent reports have provided evidence that Rpd3p plays a critical role in activating genes, like the GSR genes to protect cells from an environment of acute osmotic stress. Data in Chapter 4 provided evidence that *HAC1* and *RPD3* epistatically interacted during hyperosmotic stress (Figure 4.3a). The additive growth defect of *hac1Δ rpd3Δ* double mutants (Figure 3.3) and the Northern data (Figure 4.3a) may reflect that *hac1Δ* cells retained partial Rpd3L function. The severity of transcriptional defects was more pronounced in a *RPD3* deletion strain than a *HAC1* deletion strain and this effect was observed for genes regulated by Hac1<sup>i</sup> in an Rpd3L-dependent manner [Figs. 4.3a, and (Schröder et al., 2004)].

The activation of GSR genes required Hac1p (Figure 4.3a). The presence of Rpd3 complex was essential for Hac1p to regulate GSR gene expression (Figure 4.4). It has been previously shown that Hac1<sup>i</sup> physically interacts with Rpd3 complexes (Schröder et al., 2004), suggesting that Rpd3 complexes may provide a docking platform for Hac1<sup>i</sup> on GSR promoters after acute osmotic shock. Tethering of Hac1<sup>i</sup> to GSR promoters after hyperosmotic shock to regulate GSR gene expression required Rpd3p-Sin3p HDAC and results from Chapter 4 revealed that Hac1p essentially required the Rpd3L complex to activate osmoresponsive genes during hyperosmotic shock (Figure 4.5). Using a deletion mutant strain specific to the large complex, the *SDS3* deletion, CHIP experiments revealed that the Rpd3L complex was required for anchoring Hac1p to the GSR gene promoters

(Fig. 4.5). Data from Figure 4.5 also indicated that Rpd3S complex does not contribute to GSR gene activation because there was no Hac1<sup>i</sup> enrichment observed in the *SDS3* deletion strain expressing HA-Hac1<sup>i</sup>. The role of Rpd3L in securing Hac1p to GSR gene promoters does not rule out the possibility that the Rpd3S complex might have a role in GSR gene regulation which is subject to further investigation. Moreover the interaction between the Rpd3L complex and Hac1 also raised the possibility of the UPR being responsible for epigenetically regulating GSR genes.

#### **4.4.6 *HAC1* does not contribute to nucleosome histone acetylation of GSR gene promoters**

In *S. cerevisiae*, during hyperosmotic stress the Hac1p interacted with the Rpd3p HDAC (Figure 4.3a). If Rpd3p HDAC is known to epigenetically regulate GSR genes, this study questioned whether the *HAC1* contributed to the epigenetic regulation of GSR genes. If Rpd3 deacetylates nucleosomes and Hac1p interacts with Rpd3p in regulating osmoresponsive genes, then an overexpressing *HAC1<sup>i</sup>* strain is expected to have a decrease in acetylation levels when compared to the WT strain. A *HAC1* deletion is expected to have an increase in acetylation at the GSR promoter nucleosomes. The increase of Hac1p using the *HAC1<sup>i</sup>* overexpressing strain or decrease in Hac1p level using the *HAC1* deletion strain did not have any effect on the three acetylation sites H3 K9, K18 or H4 K8 (Figure 4.6a-c). The total histone H3 density on GSR promoters when compared to the WT strain (Figure 4.6d) remained unaltered for Hac1<sup>i</sup>p overexpressing cells or in *HAC1* deletion cells. My data suggested that Hac1<sup>i</sup> does not influence promoter bound nucleosome histone deacetylation by Rpd3 bound to GSR promoters and contradicted data by de Nadal and colleagues, 2004. The data also showed that at least H3 K9, K18, and H4 K8 acetylation in GSR promoter nucleosomes increased in osmotically-stressed cells and was in agreement with previous published reports which states that gene activation corresponds with an increase in histone acetylation levels (Agricola et al., 2006; Deckert and Struhl, 2001; Johnsson et al, 2009;



Brownell et al., 1996; Howe et al., 2001; Lo et al., 2000; Syntichaki et al., 2000; Trievel et al., 1999).

The data from Figure 4.6 will be more elaborately discussed in Chapter 5 where the epigenetic effects of Rpd3 have also been analysed. Data suggested that an increase of promoter nucleosome acetylation for the three sites studied was correlative with a decrease in nucleosome occupancy (Figure 4.6). The evidence that GSR promoters displayed a significant decrease in nucleosome density upon activation (Figure 4.6d) has also been reported earlier by Mas et al., 2009. All three acetylation sites studied were relative to the total histone H3. An increase in H3K9 and H4K8 acetylation has been shown previously for recruitment of chromatin remodeling complexes and the general transcription initiation factors (Agalioti et al., 2002). An increase in acetylation for these sites observed in this study might suggest that chromatin modifying complexes like the SAGA and NuA4 HATs might be recruited to regulate GSR gene transcription. The activation of GSR genes could possibly be due to the recruitment of SAGA/Gcn5 HAT because the bromodomains of Gcn5 recognise acetylated lysine residues and is important for the expression of a number of inducible genes (Hassan et al., 2002; Zeng et al., 2008).

#### **4.4.7 Investigating the role of *RPD3* in GSR gene activation**

Data from Chapter 4 showed that Hac1p is a positive regulator of GSR genes (Figures 4.2 and 4.3a). It regulated the GSR gene expression by interacting with Rpd3L complex (Figure 4.5). Hac1p though involved in activating a subset of osmoresponsive genes, does not affect GSR nucleosomal histone acetylation levels (Figure 4.6a-c). In addition, a mechanism through which Hac1p regulated GSR for cellular protection against hyperosmotic stress still remains unanswered. The entry of Hac1<sup>i</sup> into GSR promoters does not epigenetically regulate GSR genes, because overexpression of Hac1<sup>i</sup> did not affect histone acetylation of promoter nucleosomes or nucleosome density in GSR promoters (Fig. 4.6).

Moreover, nucleosome loss, while being an essential requirement for GSR activation (Figure 4.6e and Mas et al., 2009), was not the only factor required for gene activation, because *hac1Δ* cells, which displayed similar levels of nucleosome loss as WT cells (Fig. 4.6e) were less transcriptionally active than WT cells (Fig. 4.2). Like the *hac1Δ* cells, the *rpd3Δ* cells also had low levels of GSR gene induction when compared to the WT cells (Fig. 4.2) as reported previously. Chapter 5 provides mechanistic insight into how *RPD3* converges into the osmotic stress and ER stress signalling pathway.

CHAPTER 5

---

**THE ROLE OF *RPD3-SIN3* HDAC IN GSR GENE REGULATION**

The Rpd3 HDAC has been well characterised under different stress responses. Rpd3p is known to repress genes but recent reports (de Nadal et al., 2004; Sertil et al., 2007) suggest that it can activate various subsets of genes under different environmental stresses. Data from Chapter 4 showed that Hac1p acted through Rpd3p to regulate GSR gene expression (Figure 4.3a). The positive role of Hac1p in activating GSR genes strictly required the Rpd3p large complex (Figures 4.4 and 4.5). Moreover, the transcriptional read-out of a *RPD3* deletion strain was weaker than a *hac1Δ* strain (Figures 4.2 and 4.3a) suggesting that the Rpd3p molecule played an important role during hyperosmotic shock. Moreover, these data suggested that the role of Rpd3 in regulating GSR gene expression was critical. To investigate the role of Rpd3p genetically and biochemically in GSR gene regulation the following questions in Chapter 5 were addressed:

1. How does *RPD3* regulate GSR gene expression? Is the acetylation levels affected by *RPD3* during GSR gene activation?
2. Data from Chapter 4 suggested that it is the Rpd3L complex which tethers Hac1<sup>i</sup> to GSR gene promoters; can these results be genetically confirmed by showing causality that it is the Rpd3L complex and not the Rpd3S complex involved in GSR gene activation?
3. Is the deacetylase activity of the Rpd3 HDAC essential for regulating GSR genes?

### **5.1 Rpd3 complexes are associated with GSR promoters independent of osmotic stress.**

Hac1p acted through Rpd3p to activate GSR genes (Chapter 4). In addition, altering *HAC1* expression levels did not affect acetylation levels for GSR gene activation under hyperosmotic stress (Figure 4.6). Deacetylation of promoter bound nucleosomes by Rpd3 has been shown to be a cause for GSR gene activation (de Nadal et al., 2004). Data in Chapter 4 indicated that Hac1p acting via Rpd3L, does not affect nucleosomal histone acetylation levels. Consequently, the

histone acetylation data was in agreement with previous published reports demonstrating an increase in acetylation which correlated with an increased transcriptional output and vice versa (Rundlett et al., 1998; Deckert and Struhl, 2001; Braunstein et al., 1993; Agricola et al., 2006). To understand how the Rpd3 HDAC contributed towards effecting nucleosomal histone acetylation pattern and thereby epigenetically regulating GSR genes, a CHIP analysis was performed to assess the role of *RPD3* before and after hyperosmotic stress.

A *RPD3* deletion strain was subjected to hyperosmotic shock and characterized for acetylation of H3 K9, H3 K18, and H4 K8 at the promoters of 4 GSR genes, *CTT1*, *ALD3*, *STL1* and *HSP12* (Figure 5.1). As with previous histone acetylation CHIP experiments, the acetylation signals were normalized to the total H3 histone signal. As observed previously in Figure 4.6a-c, osmotically-stressed WT cells showed increased acetylation of H3 K9, H3 K18, and H4 K8. Deletion of *RPD3* was expected to increase the overall histone acetylation levels. A *RPD3* deletion strain indeed elevated nucleosomal histone acetylation at the GSR promoter regions to levels comparable to osmotically-stressed WT cells (Figure 5.1a-c). In addition, the acetylation levels were comparable before and after hyperosmotic stress for *rpd3Δ* cells, for the three acetylation sites. The *rpd3Δ* cells also displayed lower H3 histone promoter occupancy in unstressed condition though the nucleosome loss was not as drastic as observed in the WT strain after osmotic shock (Figure 5.1d). The nucleosome loss for the *RPD3* deletion strain was comparable to the WT strain but the induction level GSR genes was not comparable between the two strains after osmotic shock (Figure 5.1d) (Figure 4.2). Data from Figure 5.1 and defective GSR mRNA production by osmotically-stressed *rpd3Δ* cells (Figure 4.2) suggested that Rpd3 promoted activation of these genes after nucleosome loss from GSR promoters had occurred.

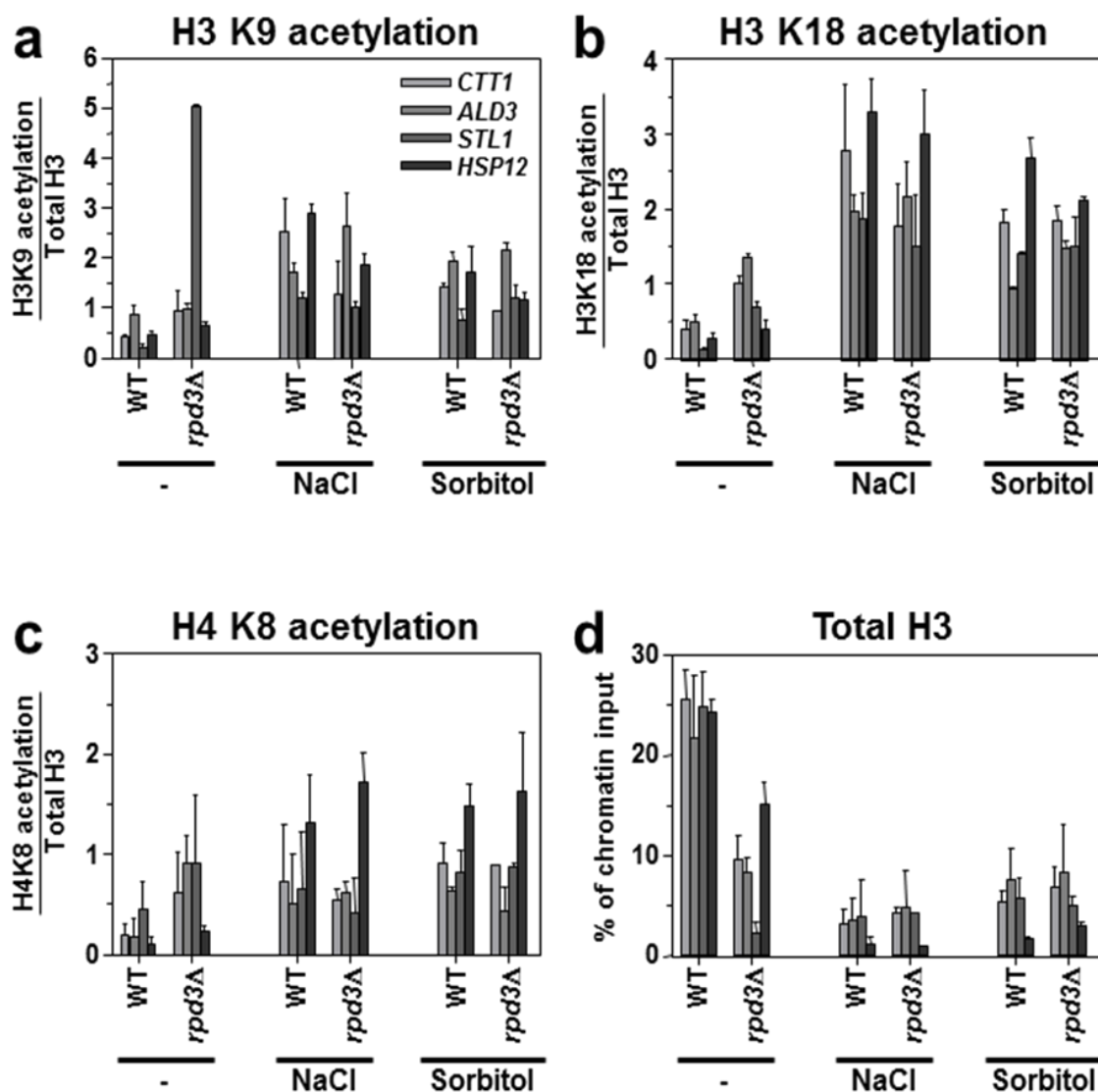

**Figure 5.1 Deletion of *RPD3* increases nucleosomal histone acetylation before and after hyperosmotic stress** (a-c) Nucleosome acetylation in the promoters of *ALD3*, *CTT1*, *HSP12*, and *STL1* for the indicated acetylation sites in unstressed and stressed WT (MSY 134-36) and *rpd3Δ* (MSY 287-01) cells transformed with pRS314 was assayed using ChIP. (d) Histone H3 density measured by ChIP in the promoters of the genes and strains in panels (a-c). The cells (a-d) were grown to mid-log phase in SD-Trp medium at 30°C. The cells were then treated with 0.6 M NaCl and 1.2 M sorbitol for 20 min and crosslinked with 1% (w/v) formaldehyde. The ChIP protocol and analysis were as done in previous chapters. The average values of two independent experiments with standard errors of the mean are shown in the figure.

In Figure 5.1, an increase in acetylation was observed for the three sites in the WT strain after osmotic shock. At least a two fold increase in acetylation for the H3 K9, H3 K18, and H4 K8 acetylation was also observed in unstressed *rpd3Δ* cells when compared to the WT strain (Figure Durham University | 133

5.1a-c). This indicated that the Rpd3p complex occupied GSR promoters in unstressed cells. Previous reports have indicated that it has been difficult to ChIP Rpd3p to gene promoter regions using standard ChIP experiment protocols (Kurdistani et al., 2002). Since Sin3p and Rpd3p are closely associated in the Rpd3 complex (Kadosh and Struhl, 1997), tagging Sin3 would provide an accurate estimate of Rpd3 binding. A MYC-tagged Sin3 was ChIPed as a surrogate for Rpd3 to GSR promoters to directly test this hypothesis. The Sin3-MYC enrichment for the tagged strain was normalized to the untagged WT strain (Figure 5.2). As seen in Figure 5.2, Sin3p occupied GSR promoters in unstressed cells. In addition, Sin3p enrichment levels do not alter much before and after osmotic shock.

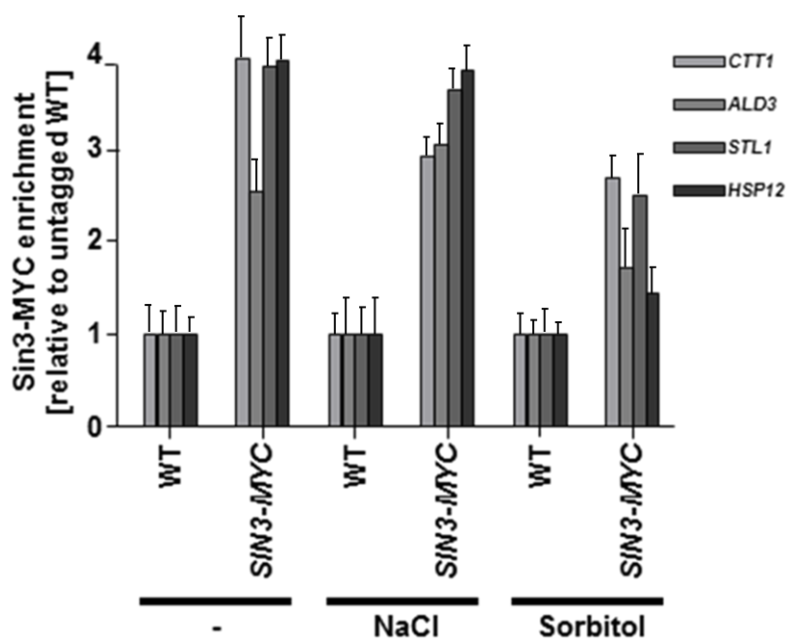
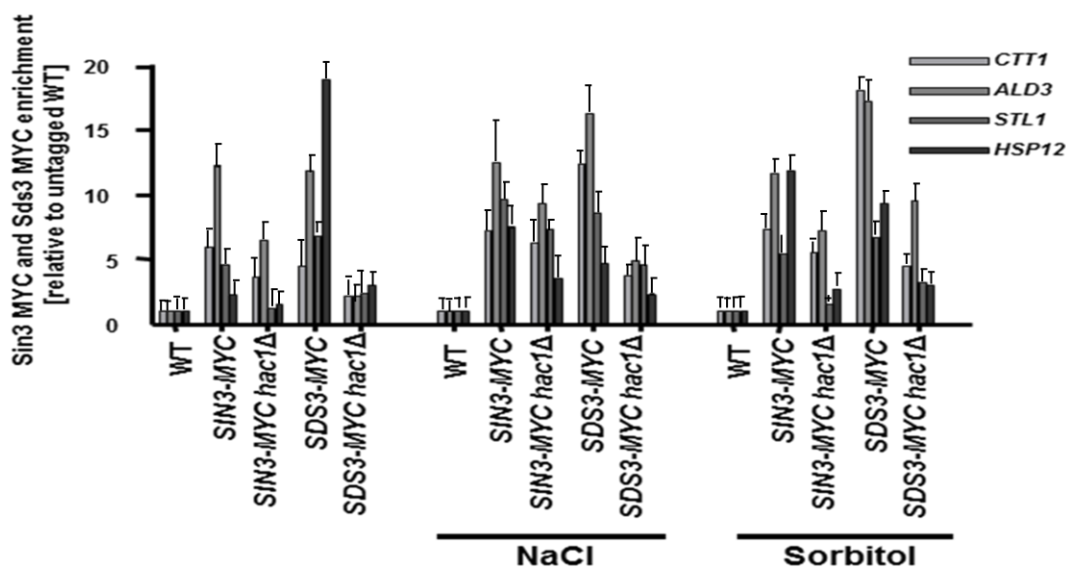

**Figure 5.2 Rpd3 complexes at GSR promoters are present before and after osmotic stress**

Sin3-MYC occupancy of promoters of GSR genes in an untagged WT strain (MSY 134-36) and a strain expressing MYC-tagged Sin3 (TLY 446) is shown in the figure. The results are expressed as Sin3-MYC enrichment relative to the untagged WT strain. The cells were grown to mid-log phase in YPD media at 30°C and then treated with 0.6 M NaCl and 1.2 M sorbitol for 20 min and crosslinked with 1% (w/v) formaldehyde. The ChIP protocol as described in Chapter 2 was followed and the immunoprecipitated (IP) DNA was analysed using real time PCR. The average of two independent biological repeats with standard errors is shown in the figure.

Figure 5.1 showed that an increase in acetylation levels after osmotic stress was comparable in WT cells and *rpd3Δ* cells. Data in Figure 5.2 showed that Rpd3 complexes occupied GSR promoter regions before and after osmotic stress. Rpd3p was a contributing molecule for GSR gene induction after osmotic stress. CHIP data in Chapter 4 (Figure 4.5) showed that the Rpd3L complex interacted with Hac1p during GSR gene activation and served as a docking molecule for Hac1p. Again, data in Figure 5.2 lacked information on whether was the Rpd3 small or the large complex which positioned itself at the GSR gene promoters. Moreover, if it is the Rpd3L complex that interacted with Hac1p as observed before (Figure 4.5) then it is possible that deletion of *HAC1* would affect the presence of Rpd3L complex at the GSR promoters during hyperosmotic shock. A CHIP experiment in Figure 5.3 addressed the aforementioned posed hypotheses. A similar set up of CHIP experiment as in Figure 5.2 was performed but with three additional strains. As observed in Figure 5.3, using a MYC-tagged Sds3 strain, *SDS3* being the Rpd3L complex specific subunit would show whether the Rpd3L complex occupies the GSR promoter regions. Using strains having a *HAC1* deletion in a MYC-tagged Sin3 or MYC-tagged Sds3 would indicate whether *HAC1* affects the association of Rpd3 complexes to GSR gene promoters. The CHIP experiment was expressed as fold enrichment relative to the untagged WT strain. In Figure 5.3, there was a strong enrichment of the Sds3-MYC tagged strain before and after osmotic stress as it was for the Sin3-MYC strain as observed previously (Figure 5.2). *HAC1* deletion affected Rpd3p association to GSR promoter regions as the Sin3-MYC strain and Sds3-MYC strains because a *HAC1* deletion lowered the enrichment level of the Rpd3L complex.

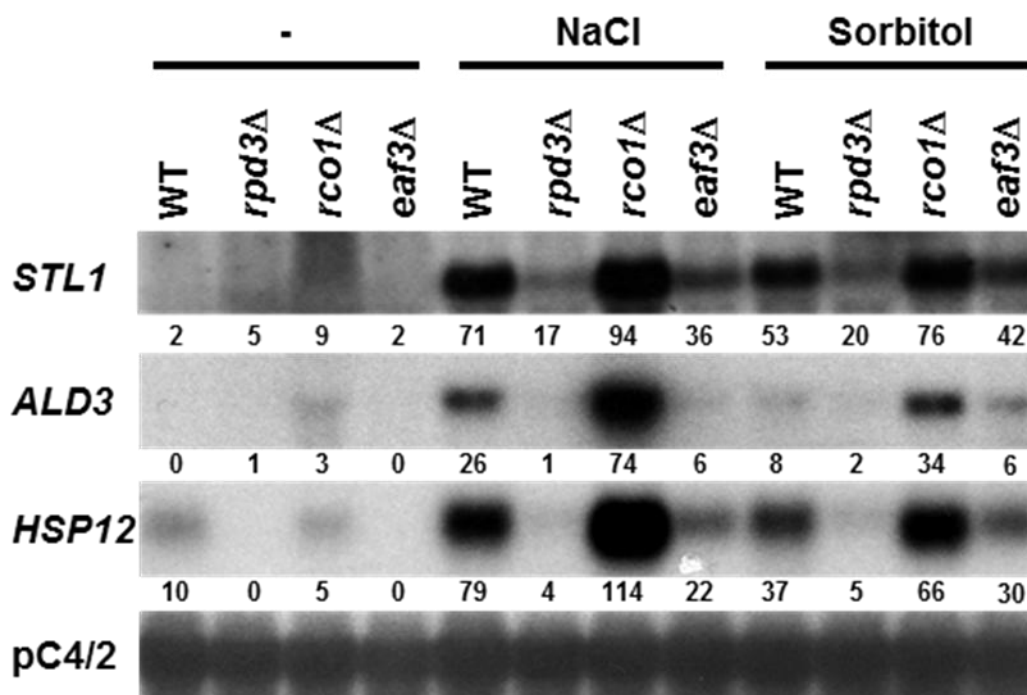



**Figure 5.3 The Rpd3L complex interacts with Hac1p and is present at GSR promoter regions before and after osmotic stress** Rpd3L occupancy of promoters of GSR genes in an untagged WT (MSY 134-36 + pRS314), strains transformed with pRS314 expressing MYC-tagged Sin3 (TLY 446) and Sds3 (MSY 726-03) and a *hac1Δ::Trp* in either of the two tagged strains, MSY 727-03 and MSY 728-07. The cells were grown to mid-log phase in SD-Trp media at 30°C and then treated with 0.6 M NaCl and 1.2 M sorbitol for 20 min and crosslinked with 1% (w/v) formaldehyde. The ChIP protocol as described in Chapter 2 was followed and the immunoprecipitated (IP) DNA was analysed using real time PCR. The IP DNA was quantified using the RotorGene 3000 software and further calculations using MS Excel spreadsheets. The average of two independent experiments with standard errors is shown in the figure.

The large Rpd3 complex, which includes Sap30, Pho23, Rxt1, Rxt2, Dep1, and Sds3, has been shown to be the gene promoter-targeting form of the two complexes and is required for expression of the GSR genes *ALD3* and *CTT1* in heat-shocked cells (Ruiz-Roig et al., 2010). Rpd3L is also required for expression of other subset of genes in response to various stresses; *DAN1* and *TIR* genes during anaerobic stress (Sertil et al., 2007); *RNR3* and *HUG1* during DNA damage response (Sharma et al., 2007). These reports published after the year 2005 genetically validate the association of Rpd3L and not the Rpd3S complex, to promoter bound activation of genes. Data in chapter 4 and Figure 5.3 provided evidence through ChIP experiments that the GSR gene activation required the Rpd3 large complex. A representative Northern blotting experiment (Figure 5.5) provided causality that it was the Rpd3L HDAC complex involved in the regulation of

GSR genes during hyperosmotic shock. The Northern blot data in Figure 5.5 does not rule out the possibility of Rpd3S complex in GSR gene regulation. Hence, another representative Northern blotting experiment (Figure 5.4) provided genetic evidence that the Rpd3S complex was not involved during activation of GSR genes. The Northern blotting results presented in the next segment made use of specific deletion mutant strains to prove the results. For Rpd3S complex not to be involved in activating GSR genes, the gene expression levels in small complex mutants were expected to be comparable to a corresponding WT strain. GSR gene expression in *rco1Δ* cells was enhanced during osmotic shock and the induction level of *STL1*, *ALD3* and *HSP12* GSR genes was higher than the WT strain (Figure 5.4). The mRNA levels were consistently elevated in *eaf3Δ* cells when compared to *rpd3Δ* cells (Figure 5.4). Data from Figure 5.4 provided evidence that the Rpd3S was dispensable during hyperosmotic shock. Data in Figure 5.5 concurrently provided evidence that it was the Rpd3L complex and not the Rpd3S complex which was required for GSR gene regulation during hyperosmotic shock.



**Figure 5.4 The Rpd3S complex is dispensable for induction of GSRs by osmotic stress** For the Northern blotting experiment, cells were grown in YPD medium until mid-log phase at 30°C. The deletion strains of the Rpd3 small complex, *rco1Δ* (MSY 723-01) and *eaf3Δ* (MSY 721-01), WT (MSY 134-36) strain and an *rpd3Δ* (MSY 287-01) strain were then subjected to hyperosmotic osmotic shock for 20 min with 0.6 M NaCl and 1.2 M sorbitol. The RNA was isolated and 10μg was loaded on the gel. The blot was probed for the GSR representative genes *STL1*, *ALD3* and *HSP12*, and *pC4/2*, the loading control. The experiment was repeated two times with similar outcomes and the figure is a representative of one biological repeat. The quantitation for each lane was done using the phosphoimager and the values obtained from the loading control were used for normalisation. Chapter 2 describes how the quantitation numerals were generated.

Deletion of the Rpd3L-specific subunit *SDS3* recapitulated the transcriptional defects of *rpd3Δ* and *sin3Δ* cells more closely than deletion of *RCO1* or *EAF3* (Figure 5.5). The ChIP biochemical analysis and Northern blotting genetic analysis provided evidence that it is the Rpd3L complex and not the Rpd3S complex which was involved in activating GSR genes under hyperosmotic shock.

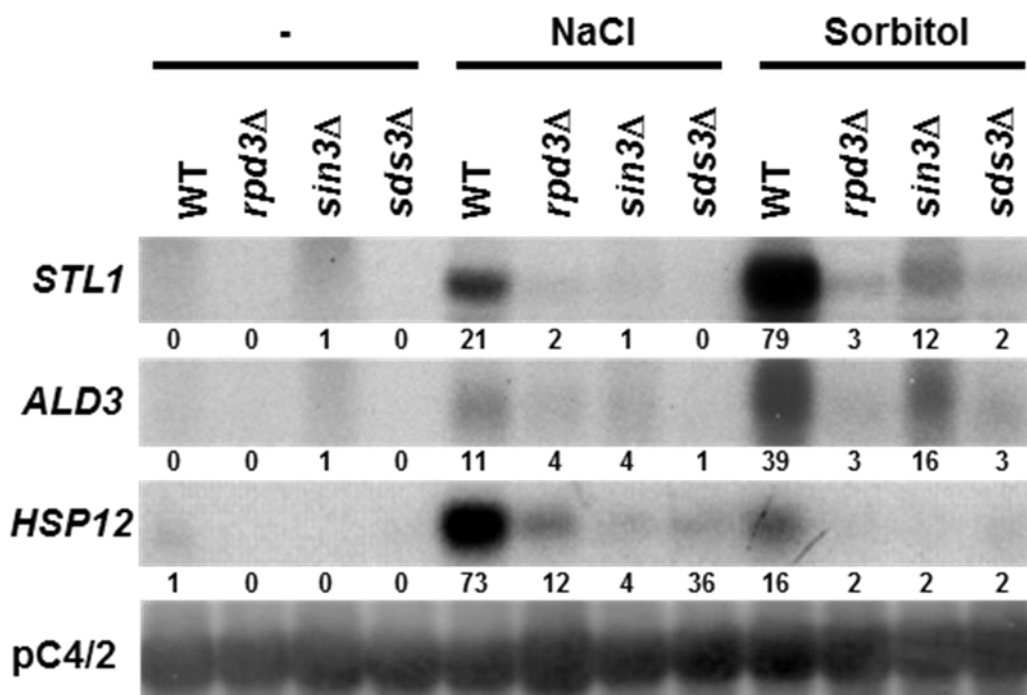
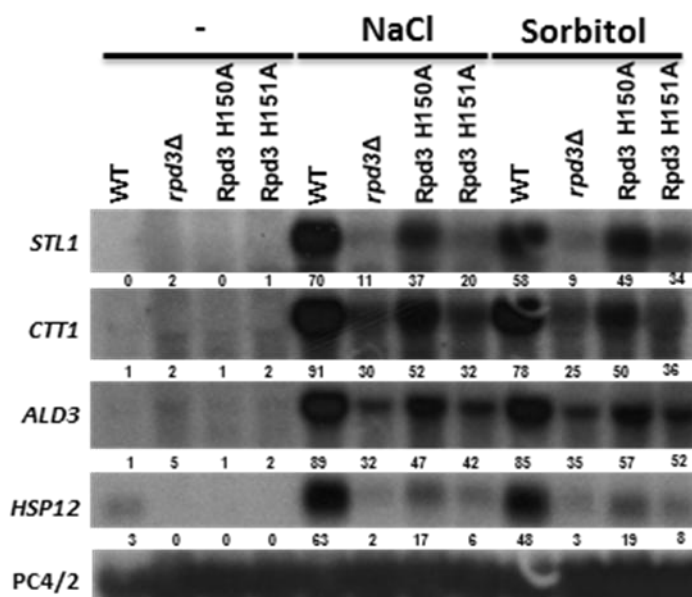

**Figure 5.5 The Rpd3L complex is required for induction of GSR genes by osmotic stress** For the Northern blotting experiment cells were grown in YPD medium to mid-log phase at 30°C. WT (MSY 36-34), *rpd3Δ* (MSY 42-38), *sin3Δ* (MSY 49-06) and *sds3Δ* (MSY 56-01) strains were treated with 0.6 M NaCl and 1.2 M Sorbitol for 20 min. The RNA was isolated and 10µg of RNA was loaded for the gel run and probed for three GSR genes *STL1*, *ALD3* and *HSP12* and the loading control pC4/2. The Northern blot has been repeated thrice showing similar results and the figure is a representative of one independent biological repeat. The quantitation for each lane was done using the phosphoimager and the values obtained from the loading control were used for normalisation.

## 5.2 The GSR gene activation is partially independent of Rpd3p catalytic activity

Previous reports which show the positive role of Rpd3p in gene activation have indicated that this HDAC enzyme requires its catalytic activity to manifest gene expression under different stress environments (Sertil et al., 2007; de Nadal et al., 2004). To investigate whether the catalytic activity of the *RPD3-SIN3* HDAC was required for GSR gene regulation, point mutant alleles of *RPD3*, H150A and H151A were studied for their effects with or without osmotic stress. These point mutants are devoid of detectable histone deacetylase activity *in vitro* and are also defective in repression of target promoters *in vivo* (Kadosh and Struhl, 1998). However, interaction of Rpd3p with Sin3p remains unchanged by these point mutations *in vivo* (Kadosh and Struhl, 1998).

A *RPD3* deletion strain had poor gene induction levels when compared to the WT strain (Figure 5.6), as also observed previously in this thesis (Figures 4.3a, 5.4 and 5.5). If effects were via the deacetylase activity of the Rpd3 enzyme then the catalytic inactive point mutants were expected to have the same transcriptional defects as a *RPD3* deletion strain. Surprisingly, the activation of GSR genes was observed to be partially independent of the Rpd3 catalytic activity (Fig. 5.6). The *rpd3Δ* cells were sensitive to osmotic stress when compared to WT strain, as observed previously. The point mutants had induction levels intermediate to those of the WT and *rpd3Δ* cells. Out of the two catalytic mutants, the H150A allele seemed to have more comparable level of induction to the WT strain. If the gene expression level of the point mutants were intermediate to the expression level of the WT strain and an *rpd3Δ* mutant, then the effect point mutants have on the nucleosome histone acetylation levels was expected to be correlative to the mRNA transcript data observed in Figure 5.6 for the point mutants.



**Figure 5.6 The GSR gene activation is partially independent of the Rpd3-Sin3 catalytic activity**

The conditions for growing cells and osmotic shock treatments are similar to the previous Northern experiment in Figure 5.5. WT (MSY 136-40), *rpd3Δ* (MSY 288-01) and Rpd3 point mutants H150A (MSY 358-03) and H151A (MSY 359-01) were probed for four GSR genes *STL1*, *CTT1*, *ALD3* and *HSP12* with or without osmotic stress. The Northern blot was repeated twice and gave similar outcomes. The figure is a representation of one biological independent experiment. The quantitation for the induction level for each gene is below each panel in the figure. *pC4/2* is the loading control and has been used for normalization.

A ChIP experiment was performed to investigate this hypothesis. The ChIP analysis in Figure 5.7 to determine the effects of Rpd3 point mutants on nucleosomal acetylation corroborated with the Northern blotting data in Figure 5.6. The WT strain and the *RPD3* deletion strain showed a similar acetylation pattern and nucleosome loss as observed in Figure 5.1. In unstressed cells, the acetylation levels of point mutants were lower than the *rpd3Δ* strain. For H3 K9 and H4 K8 acetylation, in unstressed cells, the catalytic mutants seemed to have an intermediary acetylation level when compared to the *rpd3Δ* and the WT strain (Figure 5.7a-c).

The point mutants exhibited an increase in acetylation levels for the three sites after osmotic shock and the levels were comparable to the *RPD3* deletion strain and the WT strain. The increase in H3 acetylation levels for the H151A point mutant after osmotic shock was more than the H150A

point mutant (Figure 5.7), despite the fact that the H150A point mutant had higher induction levels of GSR genes when compared to H151A point mutant (Figure 5.6). The nucleosome loss observed for the H151A point mutant was correlative with an increase in acetylation levels after osmotic stress, and so it was for the H150A mutant albeit lower than the H151A point mutant. Again, all the acetylation signals were normalized to the total histone total H3. Three acetylation sites H3K9, H3K18 and H4K8 were studied at the GSR gene promoter regions as done in Figure 5.1.

A decrease in nucleosome occupancy for the point mutants correlated with the similar levels of acetylation pattern observed for the three sites when compared to the WT strain (Figure 5.7d). In summary, data from Figures 5.6 and 5.7 indicated that the GSR gene induction levels partially overcome the need for Rpd3 catalytic activity and that the enzyme function of the molecule was not critical for GSR gene activation after hyperosmotic stress.

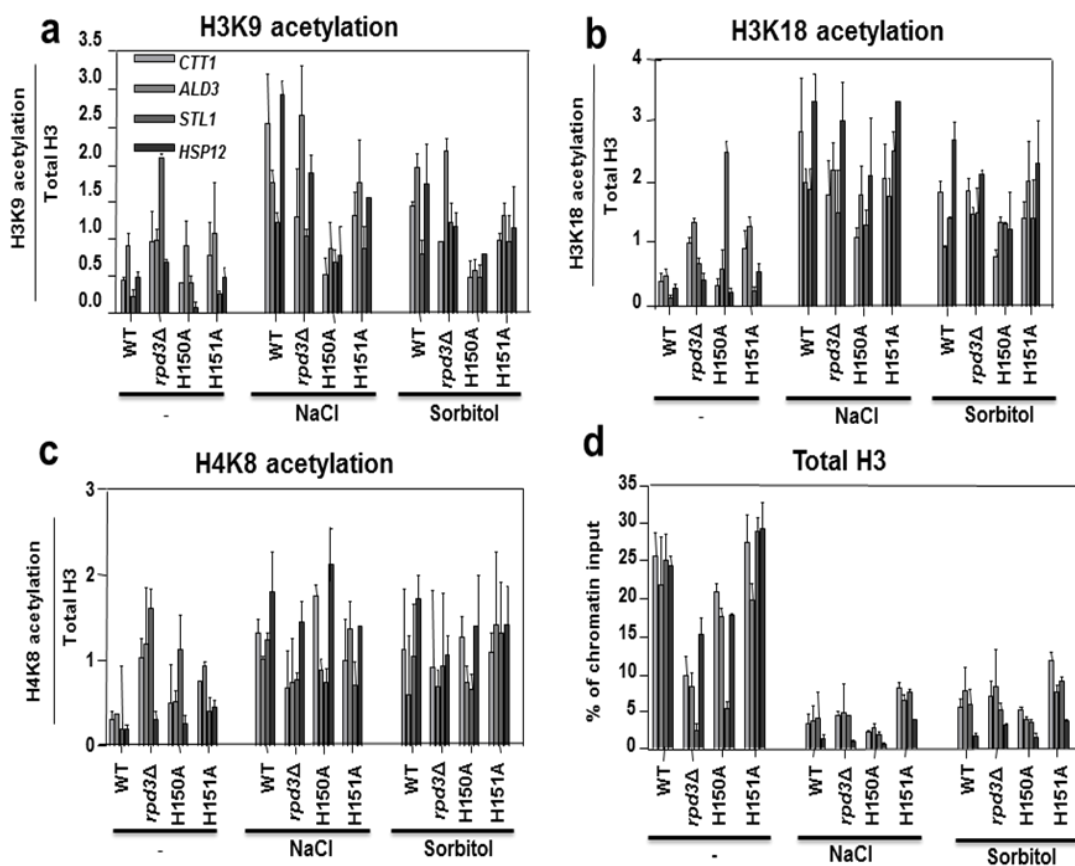

**Figure 5.7 Rpd3 point mutant acetylation levels are similar to the WT strain after osmotic stress** (a-c) shows the nucleosome acetylation in the promoters of *ALD3*, *CTT1*, *HSP12*, and *STL1* for the indicated acetylation sites in WT, *rpd3Δ*, Rpd3 H150A and Rpd3 H151A cells. These are the same strains as used Figure 5.6 but have been transformed with the pRS314 plasmid. (d) Histone H3 density measured by ChIP in the promoters of the genes and strains as in panels (a-c). The cells were grown in SD-Trp until mid-log phase at 30°C. After treating with 0.6 M NaCl and 1.2 M sorbitol, the cells were crosslinked with 1% (w/v) formaldehyde and ChIP procedure and analysis as described in Chapter 2 was followed. The RotorGene 3000 software was used to calculate the  $C_T$  values and were normalised to the input chromatin. Further calculations were done on the MS Excel sheet. The average of two independent biological repeats with the standard errors is shown in this figure.



### 5.3 Discussion

The Rpd3 HDAC is an enzyme which represses genes directly or indirectly. For example, Rpd3 HDAC is directly involved in the repression of genes in meiosis, arginine metabolism and mating type locus while an *RPD3* deletion strain is involved in enhanced heterochromatin silencing, and enhanced rRNA silencing (Kadosh and Struhl, 1997; Rundlett et al., 1996; Dorland et al., 2000; Vannier et al., 1996; Smith et al., 1999; Sun and Hampsey., 1999). The transcriptional repression of these genes by Rpd3 requires Ume6, a zinc finger protein which binds to the URS1 elements and regulates gene expression. Gene expression changes in a genome analysis during a stress response have fished out Rpd3 HDAC as a key regulator in repressing and activating various subsets of genes. In the last few years reports suggest that Rpd3p is involved in the activation of genes. These are genes to which Rpd3p binds in an Ume6-independent manner like the GSR genes (deNadal et al., 2004 Nature; Alejandro-Osorio et al., 2009; Mas et al., 2009; Ruiz-Roig et al., 2010).

#### 5.3.1 Role of Rpd3 HDAC in epigenetic regulation of GSR genes

The role of Rpd3 in osmosensitive gene regulation was first highlighted by de Nadal and colleagues (deNadal et al., 2004). The paper for the first time presented evidence on the role of Rpd3 in activating GSR genes. Recruitment of Rpd3 by the MAPK Hog1p to promoters of the GSR genes *ALD3*, *CTT1*, *HSP12*, *GRE2* and *STL1*, and deacetylation of promoter nucleosomes by Rpd3p was proposed to be required for activation of GSR genes (de Nadal et al., 2004). Since 2004, literature has demonstrated the positive role of Rpd3p in activating subsets of genes in various stress responses (Mas et al., 2009; Sertil et al., 2007; Sharma et al., 2007). In agreement with previous published reports on a positive role of Rpd3p, data in Chapter 4 indicated that the Rpd3p molecule was required for GSR gene activation as the *rpd3Δ* strain was the least transcriptionally active under osmotic stress when compared to the WT and *HAC1* mutant strains (Figure 4.2). *HAC1* acted through *RPD3* (Figure 4.3a) to regulate GSR gene expression. Hac1p does not

contribute towards the epigenetic regulation of GSR genes. The H3 K9, H3 K18 and H4 K8 acetylation levels were not affected when levels of Hac1<sup>i</sup>p were manipulated in cells (Figure 4.6). Data presented in this thesis suggested that Hac1<sup>i</sup> does not influence GSR promoter bound nucleosome histone deacetylation by Rpd3 and contradicted data by de Nadal and colleagues, 2004. Chapter 5 provided answers on whether Rpd3p, the interacting partner of Hac1<sup>i</sup>p, epigenetically controlled GSR gene regulation. ChIP data from Figure 5.1 showed that the *rpd3Δ* strain exhibited higher nucleosome histone acetylation levels and nucleosome loss in unstressed cells when compared to the WT strain. These data were suggestive for nucleosomal acetylation occurring before nucleosome loss to activate GSR genes. An increase in histone acetylation levels in the *rpd3Δ* strain before osmotic stress (Figure 5.1) suggested that Rpd3 complexes occupied GSR promoter regions in unstressed cells. This was indeed the case as observed in Figure 5.2, the data suggested that the enrichment of Rpd3p complex using a Sin3-MYC tagged strain as a surrogate, did not change before and after hyperosmotic stress which again deviated from findings by de Nadal et al, 2004. The MAPK Hog1p is responsible for recruiting Rpd3 complexes to GSR genes during hyperosmotic shock (de Nadal et al., 2004). Hog1p targets Rpd3p to activate osmoresponsive genes, but the article however does not have data indicating whether it is the Rpd3L or Rpd3S complex. Though the presence of two existing Rpd3 complexes was found after this report was published in 2004, there is a possibility that the Hog1p MAPK could be targeting the Rpd3S complex.

The finding that GSR gene promoter nucleosome acetylation increased in osmotically-stressed cells was in conflict with nucleosome deacetylation by Rpd3p being a positive role for Rpd3p in activation of these genes (de Nadal et al., 2004). The acetylation data was normalized to the total histone H3 whereas de Nadal and colleagues have normalized their acetylation data relative to the telomeres. An argument can be made that the differences observed in my data and in the cited paper (de Nadal et al., 2004) could be due to differences in normalization. Moreover, data provided in this thesis has correlative evidence for the role of Rpd3 in GSR gene activation. The

total H3 histone occupancy was significantly lowered at the GSR gene promoters in a *RPD3* deletion strain which facilitated GSR gene activation (Figure 5.1d). This decrease in nucleosome occupancy resulting in activation of GSR genes has been reported earlier (Mas et al., 2009). The changes in steady-state GSR promoter acetylation in *rpd3Δ* cells thus suggested that the Rpd3p functions as a classical repressing HDAC in unstressed cells. The acetylation data (Figure 5.1) and the ChIP data (Figure 5.2) on the *RPD3* deletion strain and the Sin3-MYC tagged strain respectively, suggested that Rpd3p was present before and after osmotic stress. Before osmotic stress, Rpd3p kept GSR genes repressed. The positive role of Rpd3 in activating GSR genes was when it switched from being a repressor complex to an activating complex under hyperosmotic shock. Moreover, data in Chapter 4 and Chapter 5 provided evidence that the Rpd3L and not the Rpd3S complex was responsible for GSR gene activation to protect cells under hyperosmotic shock.

### 5.3.2 The Rpd3L complex is required for GSR gene activation

Figure 4.3a showed that Rpd3p and Hac1p were epistatic to each other in regulating GSR gene expression. Figure 4.4 showed that Hac1p had a direct positive role in activating GSR genes and required the presence of Rpd3p complexes during GSR gene activation. Figure 4.5 indicated that the Rpd3L complex helped in anchoring Hac1p to the GSR gene promoter regions. Furthermore, in Chapter 5, ChIP experiments biochemically revealed that it was the Rpd3 large complex which was present at the GSR promoters before and after hyperosmotic stress (Figure 5.3). A Sin3-MYC tagged strain or a Sds3-MYC tagged strain having a *HAC1* deletion lowered the Rpd3 enrichment over the GSR promoters (Figure 5.3). This observation raised a possibility that Hac1p might affect the structural integrity of the Rpd3 complex. Experiments co-immunoprecipitating Hac1p and Rpd3p have indicated that Hac1p induces structural changes in Rpd3 complexes (Dr Martin Schröder, unpublished data). Based on the aforesaid premise, *HAC1* might affect the deacetylase

activity or the substrate selectivity of the Rpd3L complex during GSR gene regulation, which is subject to further investigation. Surprisingly, the catalytically inactive point mutants of Rpd3 unlike the *rpd3Δ* strain promoted partial activation of GSR genes after nucleosome loss (Figure 5.6 and Figure 5.7d). The acetylation pattern in unstressed cells observed for the point mutants was comparable to the WT strain (Figure 5.7a-c). The ChIP and Northern data for the Rpd3 point mutants H150A and H151A suggested that the GSR gene activation was partially independent of the Rpd3 catalytic activity. Rpd3 HDAC has a third catalytic residue, H188 and this third catalytic mutant H188A has been studied under nutritional stress earlier (Schröder et al., 2004). This study did not use the H188A Rpd3 catalytic mutant because it has been investigated earlier that either of the single point mutants H150A or H151A have a better phenotypic response than the H188A mutant allele. The H188A mutant disassembles the Rpd3 complexes in co-IP experiments when studied at endogenous levels (Dr Martin Schröder, unpublished data). The catalytic role of the H188A mutant in Rpd3p mediated activation has been reported earlier (Sertil et al., 2007) but Sertil and colleagues have not provided information on either the H150A point mutant or the H151A point mutant. Northern blotting (Figures 5.4 and 5.5) indicated causality that it is the Rpd3L complex and not the Rpd3S complex which was present on the GSR gene promoters after osmotic stress. Deletion of *SDS3*, a subunit specific to the Rpd3L complex interfered with activation of GSR genes (Figure 5.5), while deletion of *RCO1* in cells, a subunit specific to Rpd3S, revealed that Rpd3S was dispensable for activation of GSR genes (Figure 5.4). The evidence provided in Chapter 5 on the presence of Rpd3L and not Rpd3S complex on the GSR gene promoters do not nullify the role of Rpd3S complex in GSR gene activation. The presence of the Rpd3L complex was seen at the promoter regions of GSR genes. Increased induction levels of GSR genes in the Rpd3S complex mutants after osmotic stress (Figure 5.4) suggested that the small complex might be recruited to GSR genes to prevent spurious transcription in the ORFs of the GSR genes after hyperosmotic stress. The Rpd3 large and small complexes have significant roles in epigenetically regulating genes. While Rpd3L is known to mediate promoter bound activation or

repression, histone deacetylation by locally recruited Rpd3S is an important event that is key to the suppression of spurious transcription initiation within an ORF (Carrozza et al., 2005; Joshi and Struhl, 2005; Keogh et al., 2005). Rpd3S and Set2 methyltransferase act together to prevent cryptic transcription initiation (Bing et al., 2007a). The plant homeobox domain (PHD) of the *RCO1* subunit and the chromodomain of the *EAF3* subunit of the Rpd3S complex is directed to transcribed chromatin in order to recognise methylated histone H3 lysine 36 (Bing et al., 2007). This Set2-Rpd3S mechanism of preventing spurious cryptic transcription initiation within the ORFs could be a role of Rpd3S complex in GSR gene regulation. The presence of Set2 on promoter regions has been shown to cause transcription inhibition (Strahl et al., 2002). To overcome Set2 mediated K36 methylation at the proximal regions of the promoters, cells have evolved more than one mechanism.

One such mechanism is when genes are not being transcribed, the histone variant Htz1 is localised to the promoter regions which has an inhibitory effect on the methyltransferase activity of Set2 (Li et al., 2005). When genes are being transcribed, Set2 has been shown to be RNA polymerase II dependent (Li et al., 2002 and 2003, Xiao et al., 2003, Krogan et al., 2003). Moreover, on active promoters, lysine 36 is acetylated by Gcn5 (Morris et al., 2007) thereby not allowing Set2 to methylate the lysine 36 residue. Such tightly controlled epigenetic regulatory mechanisms to provide efficient and uninterrupted transcription of genes, might be resonant in the mechanism of GSR gene activation. The induction levels of the *EAF3* deletion strain were lower as compared to the *RCO1* deletion mutant (Figure 5.4). The lower induction levels of GSR genes observed in an *EAF3* deletion strain could be suggestive of HATs having a role in GSR gene regulation as Eaf3p is a component of the NuA4 HAT (Eisen et al., 2001). The presence of HATs at the GSR gene promoters might possibly be necessary to aid in the increase of acetylation levels and balance deacetylation levels by existing HDAC complexes. In addition, HATs might also have a plausible protective role of inhibiting Set2 methyltransferase activity. Overall, data from chapter 5

provided an empirical understanding for how the Rpd3L complex and not the Rpd3S complex HDAC regulated the GSR gene expression.

### **5.3.3 Proposing a mechanism of how the UPR components regulate GSR gene expression during hyperosmotic stress**

Data in this study has identified steps which outline an order of events in the regulation of GSR genes during hyperosmotic shock. Chapter 4 showed that Hac1p and Rpd3p interacted epistatically during GSR gene activation (Figure 4.3a).

ChIP data suggested that the Rpd3L complex was required by Hac1p to facilitate its direct positive role in activating GSR genes during hyperosmotic stress (Figure 4.5). The HA-Hac1<sup>p</sup> enrichment levels in a *SDS3* deletion strain was similar to the untagged WT strain (Figure 4.5) suggesting that Rpd3p had a structural role during osmosensitive gene regulation. One role which Rpd3p performed during osmosensitive gene regulation was to credibly anchor Hac1p to GSR gene promoters. Absence of HA-Hac1<sup>p</sup> enrichment in a *SDS3* deletion strain was also correlative with the Northern blotting data in Chapter 4 (Figure 4.3a) where the deletion of *RPD3* masked the effects of a *HAC1* overexpressing strain.

The presence of Rpd3p complexes was observed before and after osmotic stress (Figure 5.2). The presence of Rpd3p complexes before osmotic stress suggested that the molecule was required for repressing GSR genes in unstressed cells. The Rpd3L complex was associated within the promoter regions of GSR genes after stress (Figure 5.3). The causality for Rpd3L complex and not the Rpd3S complex in activating GSR genes were provided by the Northern data. Deletion of *RCO1*, a subunit specific to Rpd3S derepressed GSR genes while deletion of the Rpd3L specific subunit *SDS3* in cells recapitulated the GSR gene activation defect of *rpd3Δ* cells. Data also showed that the increase in GSR mRNA levels corresponded with an increase in acetylation levels (Figure 4.6 and Figure 5.1). Moreover, deacetylation by Rpd3p was also not critical for activating GSR genes after

hyperosmotic shock because Rpd3p point mutants resulted in a partial GSR gene expression (Figure 5.6).

All these experimentally validated results strengthened the idea that Rpd3p while acting as a classical repressor before osmotic stress might have to potentially compete with incoming HAT enzymes like Gcn5p before and after osmotic stress. The Rpd3p and putative HATs vie against each other because both molecules have common enzyme substrates- the lysine residues on the N terminal histone tails of core histones. On the basis of the acetylation patterns and Northern analysis data presented in Chapter 4 and Chapter 5, a mechanism seems to operate the regulation of GSR genes during hyperosmotic stress. A potential balance of acetylation and deacetylation keep the GSR genes inactive in unstressed cells and hence a 'switch-off' mode. HATs, such as NuA4 or Gcn5-containing HATs are expected to be associated with GSR promoters in unstressed cells. The shifting of this balance in favour of acetylation, either through recruitment of additional HATs or through direct regulation of promoter-associated HAT and HDAC activities, increases nucleosome acetylation which precedes the decrease in nucleosome density. Upon hyperosmotic stress, Hac1p, a bZIP transcription factor which activates a subset of GSR genes, binds to the GSR gene promoters with the aid of the Rpd3L complex. The Rpd3p acts as a docking molecule for Hac1p to activate GSR genes. During acute osmotic shock Hac1p and Rpd3p interact epistatic to each other. Whether other sequence-specific transcription factors, such as Msn1, Msn2/4, Hot1, Sko1, and Smp1, that control a small subset of GSR genes, act before or after nucleosome acetylation or nucleosome loss is currently under investigation.

#### **5.3.4 The UPR components integrate into osmotic stress**

Data from Chapter 4 and Chapter 5 showed that important UPR components integrated into osmotic stress and regulated GSR gene expression. Yet, there were data in this thesis which in spite of explicating the role of the UPR components in hyperosmotic stress raised further

fundamental questions of how GSR genes were activated. For example, *HAC1* and *RPD3* single deletion mutants in cells produced lower levels of mRNA transcript when compared to the WT strain (Figure 4.3a). Yet on analyzing the nucleosomal histone acetylation levels and nucleosome density, these two strains showed an almost similar level of nucleosome loss as a WT strain (Figure 4.6 and Figure 5.1). These unprecedented observations suggested that even though products of *HAC1* and *RPD3* functioned as regulators in activating GSR genes during osmotic stress, the mechanistic role yet remained unidentified. Chapter 6 characterizes a mechanism for how *HAC1* and *RPD3* regulate GSR gene expression.

In addition, the epigenetic studies in this thesis provided a strong indication that HATs contributed to the balance of acetylation and deacetylation in activating GSR genes. Data indicated that an increase in acetylation contributed to GSR gene activation during osmotic stress (Figure 4.6 and Figure 5.1). This thesis in Chapter 6 investigates if a potential histone acetyltransferase (HAT), the *GCN5* contributed to GSR gene activation.



## CHAPTER 6

---

# A MECHANISM OF SIGNAL INTEGRATION BETWEEN THE UPR PATHWAY AND OSMOTIC STRESS

Chapter 4 and Chapter 5 showed that the *HAC1* deletion strain and *RPD3* deletion strain had similar levels of increased nucleosome histone acetylation and nucleosome loss after hyperosmotic stress when compared to a WT strain (Figures 4.6 and 5.1). The increase in acetylation levels of these two deletion strains does not correspond to levels of mRNA transcripts they produced as both strains had weaker mRNA signals when compared to the WT strain (Figure 4.3a). This raised the question whether there was another unidentified role through which Hac1p and Rpd3p regulated GSR gene transcription. Moreover, activation of GSR genes correlated with an overall increase in acetylation. To understand how *HAC1* and *RPD3* regulated GSR gene transcription and which potential HAT caused an increase in histone acetylation levels, answers to the following questions in Chapter 6 were provided:

1. Are Hac1p and Rpd3p involved in preinitiation complex assembly at GSR gene promoters by recruiting RNA polymerase II holoenzyme (RNA pol II) to activate GSR gene transcription?
2. Do RNA pol II phosphorylation levels in the C-terminus domain (CTD) of the enzyme correspond to the RNA pol II levels at GSR gene promoters and 3'ends in WT, *HAC1*<sup>i</sup> overexpressing, *HAC1* deletion and *RPD3* deletion strains? Are Hac1p and Rpd3p involved in controlling RNA pol II release from the GSR gene promoters?
3. Does the *GCN5* HAT contribute to the increase in acetylation levels during GSR gene activation? Is Gcn5p present on the GSR gene promoter regions before and after hyperosmotic osmotic stress?

## 6.1 **Hac1<sup>i</sup> and Rpd3p stimulate the release of Pol II from the promoters of GSR genes.**

Data from Chapter 4 and Chapter 5 have shown that GSR gene activation required *HAC1* and *RPD3*. Hac1p acted through Rpd3p to activate GSR genes (Figure 4.3a). Hac1p does not affect nucleosome histone acetylation levels for GSR gene activation (Figure 4.6). Rpd3p was present at GSR gene promoters before and after stress (Figure 5.2). Moreover, data have shown that there was another positive unidentified function of Hac1p and Rpd3p during GSR gene activation because *HAC1* and *RPD3* deletion strains in spite of showing similar acetylation levels and nucleosome loss as the WT strain had defective mRNA production (Figures 4.3a, 4.6 and 5.1). To locate this positive function, pivotal target molecules in GSR transcription initiation steps were identified, molecules which acted after posttranslational modification events during the transcription process but which were critical just before transcription initiation. One such molecule was the RNA polymerase enzyme. It was expected for actively transcribed genes to have a proportional increase in RNA pol II levels. Based on data in my previous chapters, levels of RNA pol II was then expected to be less for transcriptionally sick *HAC1* and *RPD3* deletion mutant strains. ChIP was used to test this hypothesis and the results from my ChIP experiment would indicate whether deletion of *RPD3* or *HAC1* decreases entry of Pol II into GSR promoter regions. The presence of RNA pol II at four GSR gene promoters *CTT1*, *ALD3*, *STL1* and *HSP12* was tested in Figure 6.1a. The ChIP data in Figure 6.1a and 6.1b were represented as a percentage of chromatin input.

On shocking cells with 0.6 M NaCl or 1.2 M sorbitol, deletion of *RPD3* did not affect the presence of Pol II at the promoter regions of GSR genes (Figure 6.1a). In addition, over-expression of Hac1<sup>i</sup> did not increase Pol II promoter occupancy. The *hac1Δ* cells displayed a trend toward increased Pol II promoter occupancy when compared to WT cells after hyperosmotic shock (Figure 6.1a), while at the same time were defective in GSR mRNA production under osmotic stress (Figure

4.3a). This behavior of the *hac1Δ* and *rdp3Δ* cells suggested that the transcriptional defect of *hac1Δ* and *rdp3Δ* cells lay in release of Pol II from GSR promoters. To evaluate this hypothesis, RNA Pol II was ChIPed to the 3' end of GSR genes (Figure 6.1b). Pol II occupancy of the 3' ends of genes was comparable in WT cells, cells over-expressing *Hac1<sup>i</sup>*, or *hac1Δ* cells, while Pol II occupancy at the 3' end of genes appeared to be decreased in osmotically-stressed *rdp3Δ* cells (Figure 6.1b).

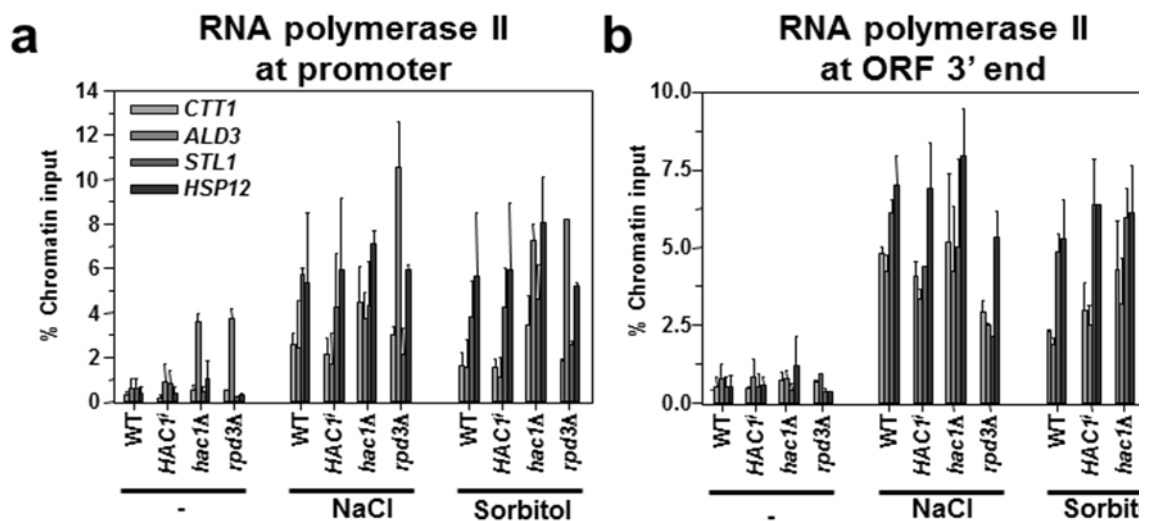

**Figure 6.1 *Hac1<sup>i</sup>* and *Rpd3p* stimulate the release of RNA pol II from the promoters of GSR genes** (a) ChIP of Pol II in WT cells transformed with pRS314 or pRS314-*HAC1<sup>i</sup>*, *hac1Δ* cells, and *rdp3Δ* cells transformed with pRS314. ChIP of Pol II to the promoter (b) and the 3' end of ORFs. The cells were grown in SD-Trp media until mid-log phase at 30°C. The cells were then treated with 0.6 M NaCl and 1.2 M sorbitol and then subsequently cross-linked with 1% (w/v) formaldehyde. The ChIP procedure was followed as described in Chapter 2 and analysis were conducted the same way as for previous ChIP experiments. The primers for the 3' end of ORFs are listed in Table 2.6, Chapter 2. The ChIP data in Figure 6.1 is expressed as a percentage of chromatin input. The average of two independent biological repeats with standard errors is shown in the figure.

A ratio for the ORF 3' end to the promoter RNA pol II occupancy showed that levels of RNA pol II after osmotic stress was more for an over-expressing *Hac1<sup>i</sup>* strain and lesser for a *HAC1* deletion strain when compared to the WT strain (Figure 6.2). The *RPD3* deletion strain showed the least

levels of RNA pol II when compared to the WT strain. The data in Figure 6.2 correlated with the mRNA transcript levels for the same strains in Figures 4.2 and 4.3a.

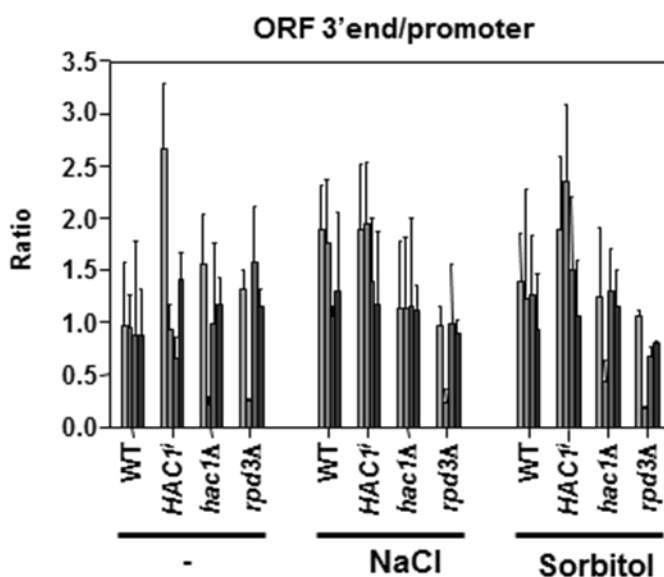
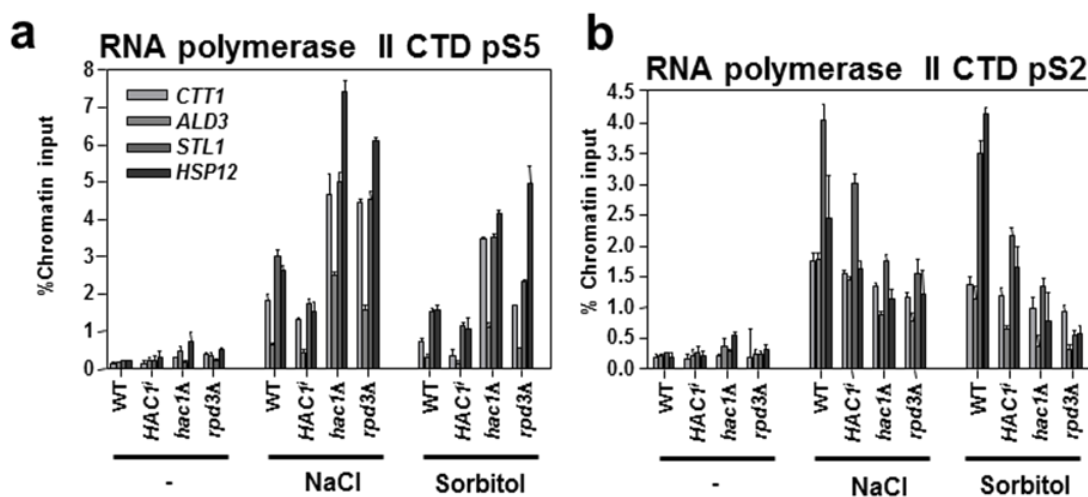

**Figure 6.2** The ratio of RNA pol II at 3' to 5' end from Figure 6.1 correlates with mRNA levels for the same strains in Figure 4.2 (c) A ratio of RNA pol II levels of 3' end to the promoters from Figure 6.1

*S. cerevisiae* genes are short, which may interfere with separation of Pol II bound to the promoter and the 3' end of a gene when using randomly-sheared chromatin in ChIP assays.

To distinguish more stringently between Pol II bound to the promoter and the 3' end of a gene, antibodies recognizing Pol II phosphorylated at serine 2 (S2) or serine 5 (S5) in its CTD were used for the study. The hyperphosphorylated S5 of RNA Pol II CTD is involved in active transcription while the hyperphosphorylated S2 of RNA Pol II CTD is important for mRNA elongation and 3' end processing (Phatnani and Greenleaf, 2006). A hypothesis was drawn that if *HAC1* and *RPD3* deletion strains showed an increase in RNA pol II levels in the GSR promoters in Figure 6.1a then these two strains were correspondingly expected to have an increase in S5 phosphorylation levels. Likewise, it was expected that the levels of S2 phosphorylation would decrease for these two strains when compared to the WT strain at the 3' end of GSR genes in Figure 6.1b.

The *hac1Δ* and *rpd3Δ* cells displayed elevated S5 phosphorylated Pol II in their promoters, while promoter-bound levels of S5 phosphorylated Pol II were decreased in *Hac1<sup>i</sup>* expressing cells when compared to the WT strain (Figure 6.2a). S2 phosphorylated Pol II at the 3' end of genes was decreased in *hac1Δ* and *rpd3Δ* cells when compared to WT cells (Figure 6.2b). These data were consistent with a positive role for *Hac1<sup>i</sup>* and *Rpd3* in promoter clearance by Pol II.

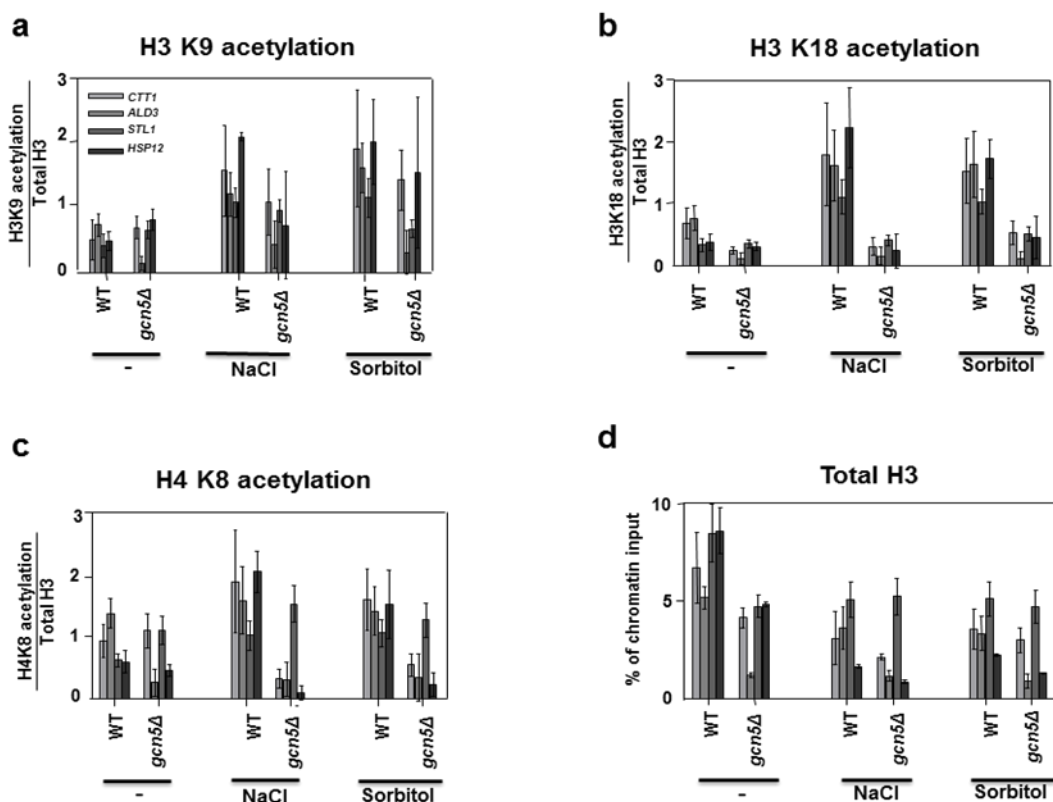

**Figure 6.3 The increase in Pol II CTD S5 and S2 levels correlates with Pol II levels at the 5' and 3' ends of GSR genes respectively** ChIP of Pol II phosphorylated at S5 (a) in its CTD to the promoter or at S2 (b) to the 3' end of ORFs for strains indicated with or without osmotic stress. The cells were grown in SD-Trp media until mid-log phase at 30°C. The cells were then treated with 0.6 M NaCl and 1.2 M sorbitol and then subsequently cross-linked with 1% (w/v) formaldehyde. The ChIP procedure was followed as described in Chapter 2 and analysis were conducted the same way as for previous ChIP experiments. The primers for the 3' end of ORFs are listed in Table 2.6, Chapter 2. The phosphorylation levels are expressed as a percentage of chromatin input. The average of two independent experiments with standard errors of the mean is represented in the figure.

## 6.2 Gcn5 HAT contributes towards increased nucleosome histone acetylation after osmotic stress

ChIP data from Chapter 4 and Chapter 5 have shown that an increase in acetylation results in increased induction of GSR genes after osmotic stress (Figures 4.6 and 5.1). The Rpd3 HDAC was present at the GSR promoters in unstressed cells (Figure 5.2). After hyperosmotic shock, the Rpd3p complex activated GSR genes by facilitating promoter clearance by RNA pol II (Figures 6.1 and 6.2). Hac1p which was tethered to the Rpd3p also facilitated promoter clearance by RNA pol II (Figure 6.1 and 6.2). This positive role of Hac1 and Rpd3 occurs after the GSR gene promoters are hyperacetylated during osmotic shock (Figures 4.6 and 5.1). The increase in acetylation levels which correlated with activation of GSR gene transcription and mRNA production suggested that a HAT was involved which contributed to the increase in acetylation levels. To investigate which HAT was involved, the presence of Gcn5 HAT at the GSR gene promoters was tested using ChIP. A *GCN5* deletion strain and a WT strain were characterised for H3 K9, H3 K18 and H4 K8 nucleosome histone acetylation before and after hyperosmotic stress at the *CTT1*, *STL1*, *ALD3* and *HSP12* GSR gene promoters. The acetylation data were normalised to the total histone H3.

For the H3 K9, H3 K18 and the H4 K8 lysine residues, the overall acetylation levels in a *GCN5* deletion strain were low after hyperosmotic stress treatment when compared to the WT strain. Moreover, the H3 K18 acetylation levels were drastically lowered before and after osmotic stress in the *GCN5* deletion strain when compared to the WT strain (Figure 6.4). The nucleosome loss for the *GCN5* deletion strain was not significantly altered after osmotic stress (Figure 6.4d).

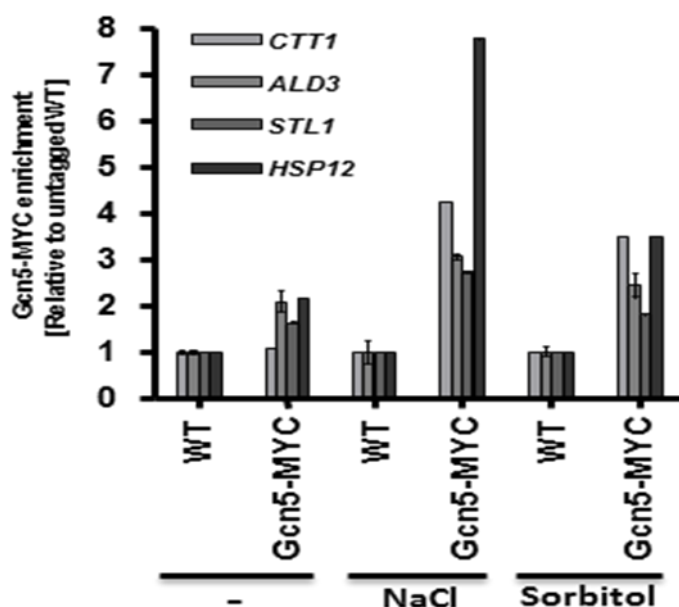

**Figure 6.4 Gcn5 HAT contributes towards increased nucleosome acetylation after osmotic stress** ChIP of a *GCN5* deletion strain (MSY 718-01+pRS314) and a WT (MSY 134-36+pRS314) strain for three acetylation sites (a-c) and nucleosome loss (d). The cells were grown in SD-Trp media until mid-log phase at 30°C. The cells were then treated with 0.6 M NaCl and 1.2 M sorbitol and then subsequently cross-linked with 1% (w/v) formaldehyde. The ChIP procedure was followed as described in Chapter 2 and analysis were conducted the same way as for previous ChIP experiments using the RotorGene software and MS Excel. The acetylation levels are normalised to the total histone H3. The average of two independent experiments with standard errors is represented in the figure.

Data from Figure 6.4 showed that a HAT which contributed to the increase of nucleosome histone acetylation after osmotic shock was Gcn5p. The acetylation levels were lowered for the three acetylation sites after osmotic stress in a *gcn5Δ* strain (Figure 6.4). Data in Figure 6.4 showed that the acetylation levels for the *GCN5* deletion strain were remarkably low in unstressed cells for H3 K18 acetylation, and for H4 K8 acetylation at *ALD3* and *HSP12* promoters when compared to the WT strain. The data in Figure 6.4 suggested that Gcn5 associated with GSR gene promoters after osmotic stress and possibly before stress at gene specific promoters. To investigate this hypothesis, a ChIP experiment was performed using a Gcn5-MYC tagged strain to estimate Gcn5p



levels before and after stress. The ChIP results were expressed as fold enrichment relative to the untagged WT strain. The results indeed showed that the Gcn5p contributed towards increase in acetylation levels after hyperosmotic shock as there was at least a 3-fold enrichment of the Gcn5-MYC tagged protein after 0.6 M NaCl and 1.2 M sorbitol treatment (Figure 6.5). A mild decrease in acetylation levels before osmotic stress (Figure 6.4a-c) also suggested that the Gcn5p was recruited to the GSR promoters before osmotic stress. There was a mild enrichment of the Gcn5-MYC tagged protein in unstressed cells (Figure 6.5) which supported the idea that a HAT like Gcn5p was recruited prior to an osmotic shock treatment and oscillated the balance between acetylation and deacetylation, tilting it more towards acetylation thereby facilitating GSR gene activation.



**Figure 6.5 Gcn5 HAT is present at GSR promoters after osmotic stress** Gcn5-MYC occupancy in an untagged WT (MSY 134-36) strain and a strain expressing MYC-tagged Gcn5 (MSY 721-01) at the promoters of GSR genes. The Gcn5 enrichment is expressed as a ratio of the tagged to the untagged strain. The cells were grown in YPD media until mid-log phase at 30°C. The cells were then treated with 0.6 M NaCl and 1.2 M sorbitol and then subsequently cross-linked with 1% (w/v) formaldehyde. The ChIP procedure was followed as described in Chapter 2 and analysis were conducted the same way as for previous ChIP experiments using the RotorGene software and MS Excel. The Gcn5-MYC enrichment is relative to the untagged WT strain. The average of two independent experiments with standard errors is represented in the figure.

## 6.3 Discussion

### 6.3.1. Signal integration between the UPR and the GSR pathways

Data from Chapter 6 provided mechanistic insight as to how essential UPR components integrated into the osmotic stress pathway. The bZIP transcription factor Hac1p and Rpd3p-Sin3p HDAC facilitated RNA pol II clearance to promote GSR gene activation (Figure 6.1 and 6.2). This work has identified control of Pol II promoter clearance by a HDAC as a point of signal integration between the UPR and the GSR pathways. Deletion of *RPD3* does not affect entry of Pol II into GSR promoters when compared to the WT strain (Figure 6.1a) whereas the RNA pol II levels were lower at the 3' end of GSR genes (Figure 6.1b). Data from Chapter 6 provided evidence that Rpd3 switched from a repressor to an activator of GSR genes and that the activating function of Rpd3 was located after entry of Pol II into GSR promoters. A proportional increase or decrease in RNA pol II levels was expected for WT or mutant strains, which exhibited an increase or decrease in mRNA levels. As observed in Figure 6.2, for the ratio of RNA pol II at the 3' end to the promoters, the *HAC1*<sup>i</sup>p overexpressing strain had a higher mean ratio of RNA pol II while the *HAC1* deletion strain had a lower RNA pol II ratio when compared to the WT strain. The *RPD3* deletion strain had the lowest mean ratio of RNA pol II (Figure 6.2). The 3' to 5' ratio of RNA pol II of GSR genes (Figure 6.2) correlated with the mRNA signals produced by the *HAC1* and *RPD3* mutant strains (Figure 4.2 and 4.3a).

### 6.3.2. RNA pol II S5 and S2 CTD phosphorylation levels correlate with RNA pol II at 5' and 3' regions of GSR genes respectively

The largest subunit of Pol II (Rpb1) has a C-terminal domain (CTD). The phosphorylation of the CTD is an important regulatory mechanism to attract several transcription factors (Phatnani and Greenleaf, 2006). The CTD can be reversibly phosphorylated. The unphosphorylated form is recruited to the promoter while hyperphosphorylated form is involved in active transcription

(Phatnani and Greenleaf, 2006). The *RPD3Δ* and *HAC1Δ* cells displayed elevated levels of S5 phosphorylated Pol II in their promoters (Figure 6.3a), which allowed processing the positive function of Hac1 and Rpd3 in transcriptional activation of GSR genes. Binding of Hac1<sup>i</sup>p to Rpd3p complexes was one mechanism that activated this positive function of Rpd3p in Pol II promoter clearance (Figures 6.1 and 6.3), while apparently not affecting the repressing functions of Rpd3p because overexpression of Hac1<sup>i</sup> did not affect nucleosome acetylation or density in GSR promoters (Figure 4.6). Alternatively, Hac1<sup>i</sup>p may be associated transiently with Rpd3p to stimulate release of Pol II from promoters. The *HAC1Δ* and *RPD3Δ* strains accumulated S5 phosphorylated RNA pol II in their promoters, while Hac1<sup>i</sup>p overexpression decreased the amount of S5 phosphorylated Pol II in GSR promoters (Figure 6.3a). Thus, Hac1<sup>i</sup> stimulated Pol II promoter clearance by modulating the Rpd3L complex (Figures 4.5 and 6.1). co-IP experiments have revealed that Hac1<sup>i</sup>p induces structural changes in Rpd3p complexes (Dr Martin Schröder, unpublished data). This may affect either the specific deacetylase activity or the substrate selectivity of Rpd3L and may be necessary for Rpd3L to stimulate promoter clearance by RNA polymerase II.

When compared to WT cells, CTD S2 phosphorylation was also decreased in cells overexpressing Hac1<sup>i</sup>p, which may reflect a positive function for Hac1<sup>i</sup>p in elongation (Figure 6.3b). RNA pol II CTD phosphorylation along with the yeast DSIF (**D**RB **S**ensitivity **I**nducing **F**actor, an elongation factor) complex is known to recruit the Rpd3S complex to actively transcribed genes (Drouin et al., 2010). Epistatic studies between the Rpd3S complex and Hac1p to elucidate the positive role of Hac1p in elongation is subject to further investigation.

### **6.3.3. Gcn5 HAT contributes to increased nucleosomal histone acetylation of GSR genes during hyperosmotic stress**

An increase in acetylation observed after osmotic stress for GSR genes in cells quite possibly indicated the role of HATs in the transcriptional regulation of GSR genes. The Gcn5 HAT was shown to affect nucleosome histone acetylation patterns after osmotic stress (Figure 6.4) and was physically recruited to the GSR gene promoter regions to directly contribute to increasing acetylation levels (Figure 6.5). Gcn5p enrichment before osmotic stress (Figure 6.5) also indicated that the Gcn5 is recruited to the GSR promoters in unstressed cells and after osmotic stress contributed to acetylating GSR promoter nucleosomes. The increase in histone acetylation of GSR genes by Gcn5 HAT was further substantiated because the bromodomains of Gcn5 recognise acetylated lysine residues. The bromodomains is important for the expression of a number of inducible genes (Hassan et al., 2002; Zeng et al., 2008). The effects of a *GCN5* deletion strain on H3 K18 acetylation level was drastic as a decrease in acetylation was observed before and after stress when compared to the WT strain (Figure 6.4b). The effects were not as strong for the H3 K9 and H4 K8 acetylation levels before and after stress (Figure 6.4a and 6.4c). The *GCN5* HAT is part of the SAGA complex (Baker and Grant, 2007) and contributes to acetylating lysine residues mainly in histone H3 (Grant et al., 1997; Grant et al., 1999). H3 K18 could be one acetylation site through which Gcn5 regulates the expression of GSR genes. It has been shown that the Gcn5p subunit of the SAGA complex preferentially acetylates histone H3K18 on the gene promoters and that Gcn5p activity is required for removal of histone H3 from one of the promoters (van Oevelen et al., 2006). This does not rule out the possibility that other HATS might have a role in acetylating GSR promoter nucleosomes. Data in Figure 5.4 suggested that the *EAF3* deletion mutant specific to the Rpd3S complex, does not derepress GSR genes as the *RCO1* deletion mutant does. Eaf3p is a known subunit of the NuA4 HAT complex (Eisen et al., 2001) and hence the NuA4 HAT might also have a role in acetylating GSR nucleosomes.

Chapter 5 indicated that Rpd3pL occupied GSR gene promoters before osmotic stress (Figure 5.3) and after osmotic stress contributed to the increased expression levels of GSR genes by RNA pol II promoter clearance (Figure 6.1). The data from this thesis provide evidence for a mechanism which results in the activation of the GSR genes. In unstressed cells, the Rpd3p and Gcn5p are both associated with the GSR promoters. A balance between acetylation by Gcn5p and deacetylation by Rpd3p at the GSR nucleosomes eventually result in favour of acetylation. The increase of acetylation on GSR nucleosomes through Gcn5p and the control of RNA pol II promoter clearance by Hac1p and Rpd3p result in activation of GSR genes (Figures 4.6, 5.1 and 6.1). Contrary to the role of Gcn5p attributing to an increase in acetylation after osmotic stress, the molecule does not contribute to a shift in nucleosomes in order to facilitate GSR gene activation (Figure 6.5d). Chromatin remodelling complexes regulating chromatin structure and dynamics during transcription initiation are known to play a role in GSR gene transcription. The chromatin remodeler RSC removes nucleosomes from GSR promoters in stressed cells (Mas et al., 2009). RSC is recruited to GSR promoters by Hog1 (Mas et al., 2009). RSC contains four bromodomains (Carey et al., 2006). It is likely that nucleosome acetylation is a second recruitment signal for RSC to GSR promoters and a HAT contributing to this increase in acetylation is the Gcn5 HAT (Figure 6.4 and Figure 6.5). The acetylation effects of Gcn5p on the three acetylation sites were not uniform (Figure 6.4). The data from Figure 6.4 suggested that other HATs like Esa1 (Bird et al., 2002; Tamburini and Tyler, 2005) could contribute to this increased acetylation and thereby nucleosome loss because the histone H3 occupancy remained largely unaltered in the *GCN5* deletion strain (Figure 6.4d). Esa1 and Gcn5 HATs are known to act together previously to regulate gene transcription (Kremer and Gross, 2009). Whether GSR gene activation requires an interaction of both HATs is subject to further study.

#### 6.3.4. Potential integration of the UPR with other stress pathways

Hac1p acting through Rpd3p HDAC activated the GSR genes by affecting RNA pol II promoter clearance. Rpd3L, and not Rpd3S, appeared to be largely responsible for controlling Pol II promoter release, to integrate the Hac1<sup>i</sup> signal into regulation of GSR genes, and to keep GSR genes off by opposing HAT activity in unstressed cells. Rpd3S is recruited to the *GAL1-GAL10* and *SUC2* promoters by cryptic transcription to repress Pol II entry into these promoters (Pinskaya et al., 2009). Derepression of *ALD3*, *HSP12*, and *STL1* in *rco1Δ* cells indicated that a similar mechanism may repress GSR genes. Activation of *ALD3* and *CTT1* by heat shock is defective in the Rpd3L mutants (Ruiz-Roig et al., 2010). Heat-shocked *rpd3Δ* cells display a small decrease in Pol II entry into the promoters of *ALD3*, *CTT1*, and *HSP12* (Ruiz-Roig et al., 2010). This decrease in Pol II promoter occupancy appears to be smaller than the decrease that may be expected from the transcriptional defects of the *rpd3Δ* cells. Therefore, Rpd3L and Hac1<sup>i</sup> may also control release of Pol II from GSR promoters in heat-shocked cells. Heat shock disrupts protein folding homeostasis more globally than ER stress. For this reason, activation of the UPR and of Hac1<sup>i</sup> in heat-shocked cells is likely. The opposing activities of RPD3 HDAC and SAGA complexes are known to regulate heat shock gene structure and expression (Kremer and Gross, 2009). Hac1p was shown to occupy GSR gene promoters after osmotic stress (Figure 4.3), thus the potential role of Hac1p acting specifically through the SAGA activation complex or the RSC chromatin remodelling complex is yet to be determined. Overall, work in this thesis has shown that a signal from the stressed ER integrated into regulation of the GSR in osmotically-stressed cells. The contribution of the GSR to survival of several different environmental stresses suggested that the UPR and Hac1<sup>i</sup> will play similar roles in responses to other stresses.

**DISCUSSION**

## 7.1 UPR components protect cells against hyperosmotic stress

The work presented in this thesis for the first time provided insight of how the UPR linked to osmotic stress. *RPD3* was previously shown to be involved in osmotic stress. *HAC1* was shown earlier to be associated with *RPD3* under nutritional stress. The *IRE1* and *HAC1* deletion strains were sensitive to 1.2 M and 2.4 M sorbitol. The *IRE1* deletion strain was more sensitive to 2.4 M sorbitol than the *HAC1* deletion strain which suggested *IRE1* independent signalling activities during hyperosmotic stress. Ire1p is an endoribonucleokinase which acts upstream of bZIP Hac1. Point mutants in the kinase or ribonuclease domains of Ire1p have been shown earlier to make cells extremely sensitive to survive ER stress. It would be interesting to investigate the molecular effects of *IRE1*, and know if at all it integrates with other known kinases under hyperosmotic stress. The *IRE1* deletion strain was more sensitive than a *HAC1* deletion strain to 2.4 M sorbitol. This observation suggested that Ire1 endoribonucleokinase had different kinase substrates, some of which were possibly critical during osmotic stress. Moreover, the observation that the *HAC1* deletion strain was more resistant at 2.4 M sorbitol could be due to a partial protection by the unspliced Hac1p. The *HAC1* and *RPD3* deletion strains were sensitive to hyperosmotic stress individually but these two molecules acted independent of each other to protect cells during osmotic shock. Moreover, a *HAC1*<sup>i</sup> overexpressing strain provided mild resistance to varying concentrations of NaCl and sorbitol. My data collectively showed that the UPR mediated a protective role during hyperosmotic shock. The protective role of Hac1p during hyperosmotic stress was substantiated by the fact that *HAC1* splicing was observed in osmotically stressed cells. The role of *HAC1* in protecting cells may be direct or indirect. Hyperosmotic stress requires strengthening of the CW. The inability of the ER to cope with excess CW protein cargo resulted in activation of the UPR and splicing of *HAC1* mRNA, as a consequence of an indirect effect of the UPR. In a more direct role, *HAC1* was spliced to activate chaperone genes, which is a classic hallmark of the UPR pathway.



The synergistic activation of multiple stress pathways to overcome the initial phase of an environmental stress raises the possibility of having essential components of the ER pathway acting as key components for other pathways. In addition UPR components may interact with key molecules of other signaling pathways in order to maintain cellular homeostasis. Osmotic stress requires strengthening of the cell wall. Hence, the cell wall integrity pathway seems another potential pathway which coalesces with the ER and the osmotic stress pathways. Components of the UPR pathway play a role in different stresses. For example, *IRE1* deletion strain is sensitive to the cell wall poisons Congo red and Calcofluor White, the cell wall-degrading enzyme zymolyase (Scrimale et al., 2008). Likewise several mutant strains of components critical to the cell wall pathway are sensitive to ER stress (Bonilla and Cunningham, 2003; Chen et al., 2005; Scrimale et al., 2008; Torres-Quiroz et al., 2010). Consequently, ER stress causes sensitivity to cell wall stress and activation of cell wall integrity signalling. Thus in an ordered chain of signalling events there is always a likelihood of excess protein cargo on the ER. Upon osmotic stress, there seemed to be a threshold level for the ER to alleviate this excess protein cargo. On exposure to higher concentrations of osmotic stress, the ER threshold level was challenged beyond which the cells were incapable of triggering the UPR because of a translational shut-off. Overall, data from this thesis showed that molecules that were essential during the ER stress were also molecules which protected cells against hyperosmotic shock. Whether ER stress is linked to other stress responses via *HAC1* is subject to further investigation.

## **7.2 *HAC1* acts via *RPD3* to activate a subset of GSR genes**

The general stress response (GSR) activates a large set of genes. One subset of genes is the osmoreponsive genes during hyperosmotic shock. My data showed that Hac1 was a positive regulator of GSR genes. A Hac1<sup>i</sup> overexpressing strain demonstrated higher induction levels of GSR genes and a *HAC1* deletion strain exhibited lower induction levels when compared to a WT

strain. Data also showed that *HAC1* and *RPD3* belonged to the same pathway in activating GSR genes. Growth assay results showed that *HAC1* and *RPD3* acted independent of each other to protect cells from hyperosmotic shock but the GSR gene transcription data suggested that *HAC1* and *RPD3* were epistatic to each other in regulating GSR genes. Hac1p had a direct role in the positive regulation of GSR gene expression. Moreover, this direct role of Hac1<sup>i</sup>p in regulating GSR genes strictly required the presence of the Rpd3L complex. Hac1<sup>i</sup>p during UPR activation binds to gene promoters in a UPRE-dependent manner (Mori et al., 1998). In yeast, *S.cerevisiae* three positive transcriptional control elements have been identified which are activated under one particular stress or multiple stress conditions (Ruis and Schüller, 1995). One of the control elements is the Stress Response Elements (STRE) and the UPRE is a sub-type of the STRE (Schüller et al., 1994). While UPRE is specific to the UPR, it is possible that Hac1p is able to bind the STREs of the GSR gene promoters to mediate transcriptional activation during hyperosmotic stress (Schüller et al., 1994). An analysis of the gene sequences of different control elements would reveal if Hac1p is compatible in binding to the GSR STREs.

*HAC1* was not involved in the epigenetic regulation of GSR genes. Deacetylation of promoter nucleosomes by the Rpd3 HDAC was earlier shown as a mechanism of GSR gene activation. If Hac1p acted via the Rpd3L complex and had a direct role in regulating GSR gene expression then a Hac1<sup>i</sup> overexpressing strain was expected to decrease acetylation while a *HAC1* deletion strain was expected to increase acetylation levels. The promoter nucleosome histone acetylation levels for H3 K9, H3 K18 and K4 K8 acetylation remained unaltered in the *HAC1* mutant strains when compared to the WT strain. There was an overall increase in the nucleosome histone acetylation levels which correlated with a decrease in total histone H3 occupancy. Hac1 does not play a role in affecting histone acetylation levels yet there was an increase of acetylation observed after osmotic stress. These data suggested that a HAT contributed to the increase in acetylation after hyperosmotic stress.

Analysing Hac1p for regulating nucleosomal histone acetylation pattern by studying three lysine residues suggested that Hac1p might not have a role in epigenetically regulating GSR genes. Hac1p interacted with Rpd3p HDAC, but this does not negate the possibility that Hac1p might affect histone dynamics by modulating more than one molecular mark (histone modification) other than acetylation. Transcription factors act as key epigenetic marks during ER stress (Donati et al., 2006) and recent reports have suggested that it might not just be one molecular mark like acetylation which contributes to the dynamics of nucleosome movement but a combination of marks like methylation, acetylation and phosphorylation on the histone H3 and H4 tails. For example, in mouse cells it has been shown that methylated H3K4 affects the overall perpetual dynamic turnover of acetylation while methylated H3K9 does not (Hazzalin and Mahadevan, 2005). It has also been reported that Rpd3 along with Set1-mediated H3K4me regulates PHO5 expression (Wang et al., 2011). Recent reports in the past one decade on chromatin and nucleosome regulation also have a plausible hypothesis built on strong experimental evidence that there exists a 'histone code', a foreseen pattern of histone modifications most likely associated with gene activation. How and where Hac1p fits in as an epigenetic regulatory unit in activating GSR genes is subject to further investigation.

### **7.3 Role of Rpd3p in GSR gene regulation**

Results in this thesis demonstrated that a *RPD3* deletion strain had an increase in acetylation after osmotic stress for three histone acetylation lysine sites. This increase in acetylation observed for the *RPD3* deletion strain after osmotic stress correlated with a decrease in nucleosome occupancy. The data also demonstrated that there was an increase in acetylation in *rpd3Δ* cells in unstressed cells when compared to the WT strain. Further investigation revealed that the Rpd3 HDAC associated with GSR gene promoters before and after stress. The Rpd3L large complex associated with GSR promoters and Hac1p affected the association of the complex in stressed and

unstressed cells. The association of Hac1p with the Rpd3L complex and a decrease in enrichment of the Rpd3L complex in the absence of *HAC1* suggested that Hac1p affected the function of the enzyme complex. Whether it is the substrate specificity or the enzymatic activity of the Rpd3L complex that Hac1p affected during GSR gene activation is to be investigated further.

Using complex specific deletion mutant strains, my data showed the causality for the role of Rpd3L complex and not the Rpd3S complex in GSR gene activation. The Rpd3S complex mutants, the *RCO1* and *EAF3* deletion mutants had different mRNA expression levels when compared to the WT strain. The *RCO1* deletion strain caused derepression of GSR genes while the *EAF3* deletion had an intermediate induction level to the WT and *RPD3* deletion strains. Eaf3p is part of the NuA4 HAT complex. It is a possibility that the Rpd3S complex could regulate the GSR gene transcription elongation steps. Data in this thesis demonstrated that the GSR gene activation bypassed the need of Rpd3 catalytic activity during hyperosmotic stress. The Rpd3 point mutants had higher induction level of GSR genes than a *RPD3* deletion strain but lower induction levels than the WT strain. My data indicated that during GSR gene activation, the Rpd3 catalytic activity was not critical as Rpd3 had structural and regulatory roles for which the catalytic activity might not be essential. One such structural role played by Rpd3 was to tether Hac1p to the GSR gene promoters.

#### **7.4 Crosstalk between the ER stress pathway and osmotic stress**

Data in this thesis indicated that the regulatory role of Rpd3p and Hac1p in GSR gene activation was the release of RNA pol II for promoter clearance. The *hac1Δ* strain showed an increase in RNA pol II levels at the GSR gene promoters while the *rpd3Δ* strain showed a similar RNA pol II level as the WT strain. These two strains demonstrated an increase in RNA pol II levels at the GSR gene promoters in spite of having weak GSR mRNA induction levels. For the WT, *HAC1* manipulations and the *RPD3* deletion mutant strains, an increase or decrease in GSR induction levels is generally

correlative with increase or decrease in RNA pol II levels respectively. The RNA pol II levels at the 3' end of the GSR genes for the *hac1Δ* and *rpd3Δ* strains demonstrated a decrease when compared to the WT strain. The ratio of the 3' end to the 5' end of the RNA pol II levels indicated that the Hac1<sup>i</sup>p overexpressing strain had a higher ratio of RNA pol II than the WT strain while the *rpd3Δ* strain had the lowest ratio of RNA pol II levels. These data correlated with the GSR gene expression levels for the WT, *HAC1* mutants and the *RPD3* deletion strains. The RNA pol II promoter clearance by the Rpd3 HDAC was thus a signal integration event between the UPR pathway and the ER stress.

The Rpd3 HDAC was present on the GSR promoters before and after osmotic stress. Before osmotic stress the Rpd3 HDAC most likely functioned as a repressor for GSR genes whereas after osmotic shock it served as structural platform for Hac1p to bind to the GSR promoters and for promoter clearance by RNA pol II. One of the HAT contributing to the increase in acetylation during osmotic stress was Gcn5. The Gcn5 HAT contributed to the increase in H3 K9, H3 K 18 and H4 K8 acetylation. My data indicated that one of the potential lysine residues on the N-terminal core histone H3 tail which Gcn5 acted through to activate GSR genes was H3 K18. Gcn5p was enriched in the GSR gene promoter regions in unstressed cells as was the Rpd3p. The data indicated that there was a balance between deacetylation by Rpd3p and acetylation by Gcn5p before osmotic stress which eventually was in favour of acetylation after osmotic stress. This increase in acetylation preceded nucleosome loss which in turn contributed to the activation of GSR genes. Rsc has been identified as a chromatin remodeller which contributes to the shuffling of nucleosomes which in turn facilitate GSR gene activation (Mas et al., 2009). Figure 7.1 suggests a possible mechanism of GSR gene activation in the WT and the *RPD3* deletion strains. In the absence of osmotic stress, Rpd3p keeps the GSR genes repressed. Upon hyperosmotic stress, there is a balance between deacetylation and the acetylation of nucleosomes. The Gcn5 HAT contributes to this increase in acetylation after osmotic stress. Hac1<sup>i</sup>p acts as an Rpd3p dependent regulator of GSR genes and promotes GSR gene activation via the RNA pol II promoter clearance.

In an *RPD3* deletion strain, an increase in acetylation levels is observed before and after osmotic stress. Release of RNA pol II is delayed in an *RPD3* deletion strain because of which the GSR gene induction levels are weak when compared to the WT strain.

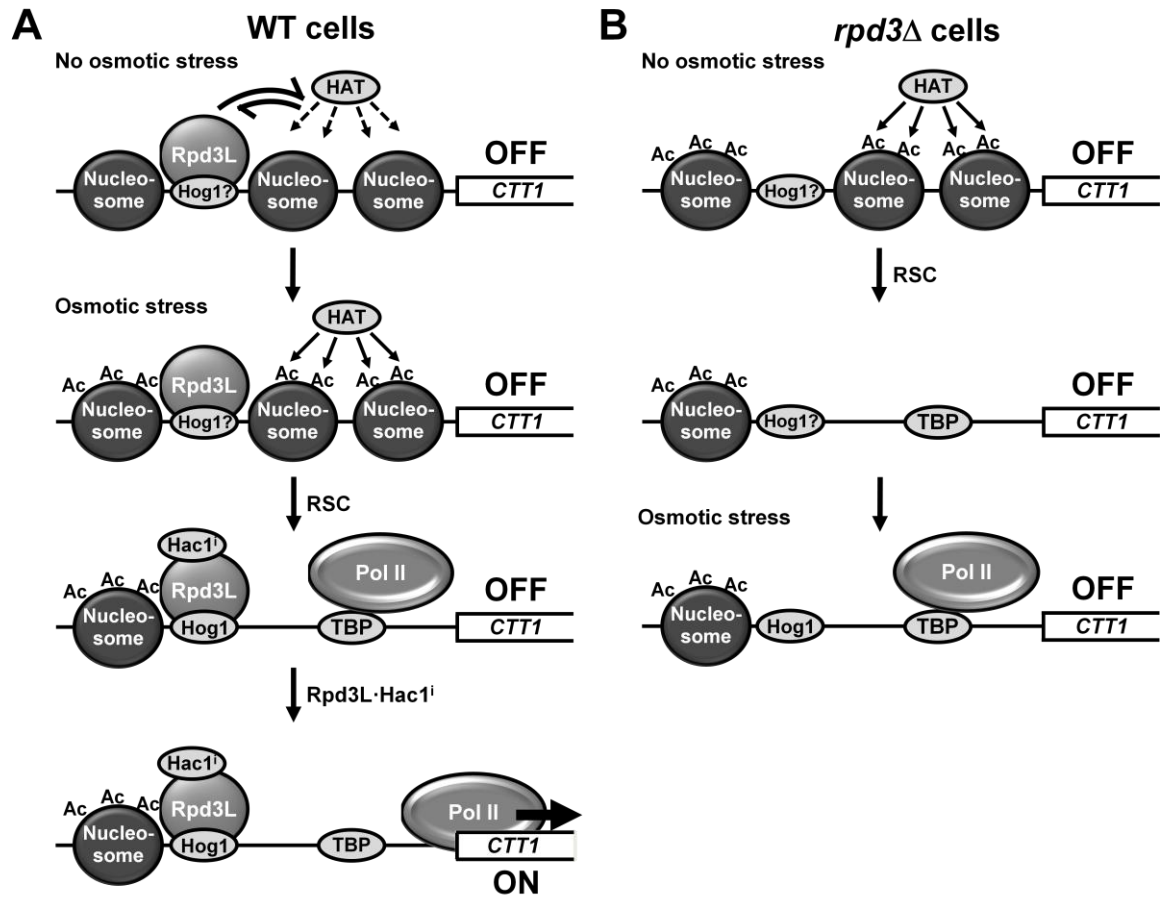

Figure 7.1 A diagram suggesting a mechanism of GSR gene activation in (A) WT and (B) *RPD3* deletion cells.

Data presented in this thesis provided a mechanistic understanding of a crosstalk between the UPR pathway and osmotic stress. Hac1 bZIP transcription factor acting through the Rpd3 HDAC have been shown to activate GSR genes by controlling the RNA pol II promoter clearance. How the ER pathway integrates with other stress pathways is currently unknown. The UPR pathway has the pivotal Ire1 endoribonucleokinase which controls *HAC1* mRNA splicing. The osmotic pathway has the Hog1 MAPK which acts downstream in the HOG pathway. How these two kinases from these two specific pathways interact upstream in the signalling cascade and whether Ire1

interacts upstream of the HOG pathway with other MAPKKs and MAPKKKs is subject to further investigation.

Hac1p was shown in this thesis to reproducibly activate a subset of GSR genes during osmotic shock. The effect of Hac1p on a genome wide scale and under different stress responses can be undertaken using ChIP sequencing analysis and genomic microarray studies. It is likely that Hac1p, the only known transcription factor to be spliced by Ire1p in the ER stress pathway quite possibly have a role in other stress pathways. The point of signal integration between ER stress pathway and osmotic stress is the Rpd3p and its role in signal integration within other stress pathways is a possibility because Rpd3p has been shown to activate various subsets of genes under different stress pathways. A mechanism identified in this thesis, that of the control of RNA pol II clearance by Rpd3 HDAC and Hac1, is specific to a set of genes like GSR or can be identified as a common mechanism in other genes regulated by Rpd3 HDAC is scope of future research. Identification of a HDAC as a signal integration point, as well as identification of a role for a HDAC in promoting Pol II promoter clearance extends our knowledge about cellular functions of HDACs. On a broader understanding, identifying different mechanisms by which molecules like the Rpd3 HDAC regulate gene expression in yeast and higher organisms is critical. Many molecules within epigenetic regulation are now targets for pharmacological interventions.

### **7.5 Epigenetic regulation, UPR and human diseased states**

Literature is accumulating which now links epigenetic regulation to human diseased states. Current evidence suggest that histone modifications can alter cellular regulation either by altering gene expression programmes or on a broader scale, affect genome integrity and chromosome segregation. For example, homozygous null mutant embryos for the gene *PR-Set7*, display early lethality due to cell cycle defects, massive DNA damage and improper mitotic chromosome condensation (Oda et al., 2009). In addition, mice deficient for the SUV 39 H3 K9 methyltransferase demonstrate reduced levels of H3 K9 di and tri methylation have impaired

genome stability and show an increased risk of developing cancer (Peters et al., 2001). My work has shown that a HDAC serves as a point of signal integration event during two stress responses. ER stress and the UPR have been implicated to several diseased states. ER  $\text{Ca}^{2+}$  buffering, and protein and lipid turnover impact many cardiac functions, including energy metabolism, cardiogenesis, ischemic/reperfusion, cardiomyopathies, and heart failure. ER proteins and ER stress-associated pathways may play a role in the development of novel UPR-targeted therapies for cardiovascular diseases (Groenendyk et al., 2010). Because increasing number of studies suggest that ER stress is involved in a number of disease pathogenesis including neurodegenerative diseases, cancer, obesity, diabetes and atherosclerosis, promoting ER folding capacity through chemical chaperones emerges as a novel therapeutic approach (Engin and Hotamisligil, 2010). Rpd3 HDAC is a critical molecule of the UPR pathway in yeast and my work shows that it integrates into osmotic stress. My work paves way for further research into a broader understanding how HDACs work during different human diseased states and stress responses. Several HDAC inhibitors are currently in clinical trials both for solid and hematologic malignancies. Thus, HDAC inhibitors, in combination with DNA-demethylating agents, chemopreventive, or classical chemotherapeutic drugs, could be promising candidates for cancer therapy (Shankar and Srivastava, 2008).



## REFERENCES

---

### A

- Ahmad, K., and Henikoff, S. (2002). Histone H3 variants specify modes of chromatin assembly. *Proceedings of the National Academy of Sciences of the United States of America* **99 Suppl 4**, 16477-16484.
- Akhtar, N., Pahlman, A.K., Larsson, K., Corbett, A.H., and Adler, L. (2000). SGD1 encodes an essential nuclear protein of *Saccharomyces cerevisiae* that affects expression of the GPD1 gene for glycerol 3-phosphate dehydrogenase. *FEBS letters* **483**, 87-92.
- Albertyn, J., Hohmann, S., Thevelein, J.M., and Prior, B.A. (1994). GPD1, which encodes glycerol-3-phosphate dehydrogenase, is essential for growth under osmotic stress in *Saccharomyces cerevisiae*, and its expression is regulated by the high-osmolarity glycerol response pathway. *Molecular and Cellular Biology* **14**, 4135-4144.
- Albig, W., Ebentheuer, J., Klobeck, G., Kunz, J., and Doenecke, D. (1996). A solitary human H3 histone gene on chromosome 1. *Human Genetics* **97**, 486-491.
- Alejandro-Osorio, A.L., Huebert, D.J., Porcaro, D.T., Sonntag, M.E., Nillasithanukroh, S., Will, J.L., and Gasch, A.P. (2009). The histone deacetylase Rpd3p is required for transient changes in genomic expression in response to stress. *Genome Biology* **10**, R57.
- Alepuz, P.M., Jovanovic, A., Reiser, V., and Ammerer, G. (2001). Stress-induced MAP kinase Hog1 is part of transcription activation complexes. *Molecular Cell* **7**, 767-777.
- Alland, L., Muhle, R., Hou, H., Jr., Potes, J., Chin, L., Schreiber-Agus, N., and DePinho, R.A. (1997). Role for N-CoR and histone deacetylase in Sin3-mediated transcriptional repression. *Nature* **387**, 49-55.
- Allard, S., Utley, R.T., Savard, J., Clarke, A., Grant, P., Brandl, C.J., Pillus, L., Workman, J.L., and Cote, J. (1999). NuA4, an essential transcription adaptor/histone H4 acetyltransferase complex containing Esa1p and the ATM-related cofactor Tra1p. *The EMBO Journal* **18**, 5108-5119.
- Allfrey, V.G., Faulkner, R., and Mirsky, A.E. (1964). Acetylation and Methylation of Histones and Their Possible Role in the Regulation of Rna Synthesis. *Proceedings of the National Academy of Sciences of the United States of America* **51**, 786-794.
- Alves, M.S., Reis, P.A., Dadalto, S.P., Faria, J.A., Fontes, E.P., and Fietto, L.G. (2011). A novel transcription factor, ERD15 (Early Responsive to Dehydration 15), connects endoplasmic reticulum stress with an osmotic stress-induced cell death signal. *The Journal of Biological Chemistry* **286**, 20020-20030.
- An, Y., Wang, Y., Lou, L., Zheng, T., and Qu, G.Z. (2011). A novel zinc-finger-like gene from *Tamarix hispida* is involved in salt and osmotic tolerance. *Journal of Plant Research* **124**, 689-697.
- Angus-Hill, M.L., Schlichter, A., Roberts, D., Erdjument-Bromage, H., Tempst, P., and Cairns, B.R. (2001). A Rsc3/Rsc30 zinc cluster dimer reveals novel roles for the chromatin remodeler RSC in gene expression and cell cycle control. *Molecular Cell* **7**, 741-751.
- Aparicio, O., Geisberg, J.V., Sekinger, E., Yang, A., Moqtaderi, Z., and Struhl, K. (2005). Chromatin immunoprecipitation for determining the association of proteins with specific genomic sequences in vivo. *Current protocols in molecular biology* / edited by Frederick M Ausubel [et al] **Chapter 21**, Unit 21 -23.

- Ashktorab, H., Belgrave, K., Hosseinkhah, F., Brim, H., Nouraei, M., Takkikto, M., Hewitt, S., Lee, E.L., Dashwood, R.H., and Smoot, D. (2009). Global histone H4 acetylation and HDAC2 expression in colon adenoma and carcinoma. *Digestive Diseases and Sciences* **54**, 2109-2117.
- Atanassov, B.S., Evrard, Y.A., Multani, A.S., Zhang, Z., Tora, L., Devys, D., Chang, S., and Dent, S.Y. (2009). Gcn5 and SAGA regulate shelterin protein turnover and telomere maintenance. *Molecular Cell* **35**, 352-364.
- Ausio, J., and Abbott, D.W. (2002). The many tales of a tail: carboxyl-terminal tail heterogeneity specializes histone H2A variants for defined chromatin function. *Biochemistry* **41**, 5945-5949.
- Ausio, J., Dong, F., and van Holde, K.E. (1989). Use of selectively trypsinized nucleosome core particles to analyze the role of the histone "tails" in the stabilization of the nucleosome. *Journal of Molecular Biology* **206**, 451-463.
- B**
- Babour, A., Bicknell, A.A., Tourtellotte, J., and Niwa, M. (2010). A surveillance pathway monitors the fitness of the endoplasmic reticulum to control its inheritance. *Cell* **142**, 256-269.
- Back, S.H., Schröder, M., Lee, K., Zhang, K., and Kaufman, R.J. (2005). ER stress signaling by regulated splicing: IRE1/HAC1/XBP1. *Methods* **35**, 395-416.
- Baetz, K.K., Krogan, N.J., Emili, A., Greenblatt, J., and Hieter, P. (2004). The ctf13-30/CTF13 genomic haploinsufficiency modifier screen identifies the yeast chromatin remodeling complex RSC, which is required for the establishment of sister chromatid cohesion. *Molecular and Cellular Biology* **24**, 1232-1244.
- Bahn, Y.S. (2008). Master and commander in fungal pathogens: the two-component system and the HOG signaling pathway. *Eukaryotic Cell* **7**, 2017-2036.
- Baker, S.P., and Grant, P.A. (2007). The SAGA continues: expanding the cellular role of a transcriptional co-activator complex. *Oncogene* **26**, 5329-5340.
- Banuett, F. (1998). Signalling in the yeasts: an informational cascade with links to the filamentous fungi. *Microbiology and Molecular Biology Reviews* : MMBR **62**, 249-274.
- Barbaric, S., Reinke, H., and Hörz, W. (2003). Multiple mechanistically distinct functions of SAGA at the PHO5 promoter. *Molecular and Cellular Biology* **23**, 3468-3476.
- Barrios, A., Selleck, W., Hnatkovich, B., Kramer, R., Sermwittayawong, D., and Tan, S. (2007). Expression and purification of recombinant yeast Ada2/Ada3/Gcn5 and Piccolo NuA4 histone acetyltransferase complexes. *Methods* **41**, 271-277.
- Bartke, T., Vermeulen, M., Xhemalce, B., Robson, S.C., Mann, M., and Kouzarides, T. (2010). Nucleosome-interacting proteins regulated by DNA and histone methylation. *Cell* **143**, 470-484.
- Beck, T., and Hall, M.N. (1999). The TOR signalling pathway controls nuclear localization of nutrient-regulated transcription factors. *Nature* **402**, 689-692.
- Becker, P.B., and Hörz, W. (2002). ATP-dependent nucleosome remodeling. *Annual Review of Biochemistry* **71**, 247-273.

- Bedford, M.T., and Clarke, S.G. (2009). Protein arginine methylation in mammals: who, what, and why. *Molecular Cell* **33**, 1-13.
- Berger, S.L. (2002). Histone modifications in transcriptional regulation. *Current opinion in Genetics & Development* **12**, 142-148.
- Bertolotti, A., Zhang, Y., Hendershot, L.M., Harding, H.P., and Ron, D. (2000). Dynamic interaction of BiP and ER stress transducers in the unfolded-protein response. *Nature Cell Biology* **2**, 326-332.
- Bicknell, A.A., Tourtellotte, J., and Niwa, M. (2010). Late phase of the endoplasmic reticulum stress response pathway is regulated by Hog1 MAP kinase. *The Journal of Biological Chemistry* **285**, 17545-17555.
- Biswas, D., Takahata, S., and Stillman, D.J. (2008). Different genetic functions for the Rpd3(L) and Rpd3(S) complexes suggest competition between NuA4 and Rpd3(S). *Molecular and Cellular Biology* **28**, 4445-4458.
- Blomberg, A., Larsson, C., and Gustafsson, L. (1988). Microcalorimetric monitoring of growth of *Saccharomyces cerevisiae*: osmotolerance in relation to physiological state. *Journal of Bacteriology* **170**, 4562-4568.
- Boles, E., and Hollenberg, C.P. (1997). The molecular genetics of hexose transport in yeasts. *FEMS Microbiology Reviews* **21**, 85-111.
- Bone, J.R., Lavender, J., Richman, R., Palmer, M.J., Turner, B.M., and Kuroda, M.I. (1994). Acetylated histone H4 on the male X chromosome is associated with dosage compensation in *Drosophila*. *Genes & Development* **8**, 96-104.
- Bonilla, M., and Cunningham, K.W. (2003). Mitogen-activated protein kinase stimulation of Ca<sup>2+</sup> signaling is required for survival of endoplasmic reticulum stress in yeast. *Molecular Biology of the Cell* **14**, 4296-4305.
- Boudreault, A.A., Cronier, D., Selleck, W., Lacoste, N., Utle, R.T., Allard, S., Savard, J., Lane, W.S., Tan, S., and Cote, J. (2003). Yeast enhancer of polycomb defines global Esa1-dependent acetylation of chromatin. *Genes & Development* **17**, 1415-1428.
- Bradbury, E.M. (1992). Reversible histone modifications and the chromosome cell cycle. *BioEssays : news and reviews in Molecular, Cellular and Developmental Biology* **14**, 9-16.
- Braunstein, M., Rose, A.B., Holmes, S.G., Allis, C.D., and Broach, J.R. (1993). Transcriptional silencing in yeast is associated with reduced nucleosome acetylation. *Genes & Development* **7**, 592-604.
- Braunstein, M., Sobel, R.E., Allis, C.D., Turner, B.M., and Broach, J.R. (1996). Efficient transcriptional silencing in *Saccharomyces cerevisiae* requires a heterochromatin histone acetylation pattern. *Molecular and Cellular Biology* **16**, 4349-4356.
- Brewster, J.L., de Valoir, T., Dwyer, N.D., Winter, E., and Gustin, M.C. (1993). An osmosensing signal transduction pathway in yeast. *Science* **259**, 1760-1763.
- Brown, A.D. (1976). Microbial water stress. *Bacteriological Reviews* **40**, 803-846.
- Brown, J.L., Bussey, H., and Stewart, R.C. (1994). Yeast Skn7p functions in a eukaryotic two-component regulatory pathway. *The EMBO Journal* **13**, 5186-5194.

- Brownell, J.E., Zhou, J., Ranalli, T., Kobayashi, R., Edmondson, D.G., Roth, S.Y., and Allis, C.D. (1996). Tetrahymena histone acetyltransferase A: a homolog to yeast Gcn5p linking histone acetylation to gene activation. *Cell* **84**, 843-851.
- Bumgarner, S.L., Dowell, R.D., Grisafi, P., Gifford, D.K., and Fink, G.R. (2009). Toggle involving *cis*-interfering noncoding RNAs controls variegated gene expression in yeast. *Proceedings of the National Academy of Sciences of the United States of America* **106**, 18321-18326.
- Buratowski, S. (2009). Progression through the RNA polymerase II CTD cycle. *Molecular Cell* **36**, 541-546.
- Buratowski, S., and Kim, T. (2010). The role of cotranscriptional histone methylations. *Cold Spring Harbor symposia on quantitative biology* **75**, 95-102.
- Burgess, S.M., Ajimura, M., and Kleckner, N. (1999). GCN5-dependent histone H3 acetylation and RPD3-dependent histone H4 deacetylation have distinct, opposing effects on IME2 transcription, during meiosis and during vegetative growth, in budding yeast. *Proceedings of the National Academy of Sciences of the United States of America* **96**, 6835-6840.

## C

- Cairns, B.R. (2005). Chromatin remodeling complexes: strength in diversity, precision through specialization. *Current opinion in Genetics & Development* **15**, 185-190.
- Cairns, B.R., Lorch, Y., Li, Y., Zhang, M., Lacomis, L., Erdjument-Bromage, H., Tempst, P., Du, J., Laurent, B., and Kornberg, R.D. (1996). RSC, an essential, abundant chromatin-remodeling complex. *Cell* **87**, 1249-1260.
- Cairns, B.R., Schlichter, A., Erdjument-Bromage, H., Tempst, P., Kornberg, R.D., and Winston, F. (1999). Two functionally distinct forms of the RSC nucleosome-remodeling complex, containing essential AT hook, BAH, and bromodomains. *Molecular Cell* **4**, 715-723.
- Calfon, M., Zeng, H., Urano, F., Till, J.H., Hubbard, S.R., Harding, H.P., Clark, S.G., and Ron, D. (2002). IRE1 couples endoplasmic reticulum load to secretory capacity by processing the *XBP-1* mRNA. *Nature* **415**, 92-96.
- Capaldi, A.P., Kaplan, T., Liu, Y., Habib, N., Regev, A., Friedman, N., and O'Shea, E.K. (2008). Structure and function of a transcriptional network activated by the MAPK Hog1. *Nature genetics* **40**, 1300-1306.
- Carey, M., Li, B., and Workman, J.L. (2006). RSC exploits histone acetylation to abrogate the nucleosomal block to RNA polymerase II elongation. *Molecular Cell* **24**, 481-487.
- Carlson, M. (1999). Glucose repression in yeast. *Current opinion in Microbiology* **2**, 202-207.
- Carrozza, M.J., Li, B., Florens, L., Suganuma, T., Swanson, S.K., Lee, K.K., Shia, W.J., Anderson, S., Yates, J., Washburn, M.P., *et al.* (2005). Histone H3 methylation by Set2 directs deacetylation of coding regions by Rpd3S to suppress spurious intragenic transcription. *Cell* **123**, 581-592.
- Causton, H.C., Ren, B., Koh, S.S., Harbison, C.T., Kanin, E., Jennings, E.G., Lee, T.I., True, H.L., Lander, E.S., and Young, R.A. (2001). Remodeling of yeast genome expression in response to environmental changes. *Molecular Biology of the Cell* **12**, 323-337.

- Chai, B., Huang, J., Cairns, B.R., and Laurent, B.C. (2005). Distinct roles for the RSC and Swi/Snf ATP-dependent chromatin remodelers in DNA double-strand break repair. *Genes & Development* **19**, 1656-1661.
- Chang, C.R., Wu, C.S., Hom, Y., and Gartenberg, M.R. (2005). Targeting of cohesin by transcriptionally silent chromatin. *Genes & Development* **19**, 3031-3042.
- Chang, C.S., and Pillus, L. (2009). Collaboration between the essential Esa1 acetyltransferase and the Rpd3 deacetylase is mediated by H4K12 histone acetylation in *Saccharomyces cerevisiae*. *Genetics* **183**, 149-160.
- Chapman, R.E., and Walter, P. (1997). Translational attenuation mediated by an mRNA intron. *Current biology : CB* **7**, 850-859.
- Chawla, A., Chakrabarti, S., Ghosh, G., and Niwa, M. (2011). Attenuation of yeast UPR is essential for survival and is mediated by IRE1 kinase. *The Journal of Cell Biology* **193**, 41-50.
- Chen, D.C., Yang, B.C., and Kuo, T.T. (1992). One-step transformation of yeast in stationary phase. *Current genetics* **21**, 83-84.
- Chen, X., Shen, J., and Prywes, R. (2002). The luminal domain of ATF6 senses endoplasmic reticulum (ER) stress and causes translocation of ATF6 from the ER to the Golgi. *The Journal of Biological Chemistry* **277**, 13045-13052.
- Chen, Y., Feldman, D.E., Deng, C., Brown, J.A., De Giacomo, A.F., Gaw, A.F., Shi, G., Le, Q.T., Brown, J.M., and Koong, A.C. (2005). Identification of mitogen-activated protein kinase signaling pathways that confer resistance to endoplasmic reticulum stress in *Saccharomyces cerevisiae*. *Molecular cancer research : MCR* **3**, 669-677.
- Choe, J., Kolodrubetz, D., and Grunstein, M. (1982). The two yeast histone H2A genes encode similar protein subtypes. *Proceedings of the National Academy of Sciences of the United States of America* **79**, 1484-1487.
- Choudhary, C., Kumar, C., Gnad, F., Nielsen, M.L., Rehman, M., Walther, T.C., Olsen, J.V., and Mann, M. (2009). Lysine acetylation targets protein complexes and co-regulates major cellular functions. *Science* **325**, 834-840.
- Chu, S., DeRisi, J., Eisen, M., Mulholland, J., Botstein, D., Brown, P.O., and Herskowitz, I. (1998). The transcriptional program of sporulation in budding yeast. *Science* **282**, 699-705.
- Clark-Adams, C.D., Norris, D., Osley, M.A., Fassler, J.S., and Winston, F. (1988). Changes in histone gene dosage alter transcription in yeast. *Genes & Development* **2**, 150-159.
- Clayton, A.L., Hebbes, T.R., Thorne, A.W., and Crane-Robinson, C. (1993). Histone acetylation and gene induction in human cells. *FEBS letters* **336**, 23-26.
- Cohen, T.J., Mallory, M.J., Strich, R., and Yao, T.P. (2008). Hos2p/Set3p deacetylase complex signals secretory stress through the Mpk1p cell integrity pathway. *Eukaryotic cell* **7**, 1191-1199.
- Colina, A.R., and Young, D. (2005). Raf60, a novel component of the Rpd3 histone deacetylase complex required for Rpd3 activity in *Saccharomyces cerevisiae*. *The Journal of Biological Chemistry* **280**, 42552-42556.

- Cox, J.S., Chapman, R.E., and Walter, P. (1997). The unfolded protein response coordinates the production of endoplasmic reticulum protein and endoplasmic reticulum membrane. *Molecular Biology of the Cell* **8**, 1805-1814.
- Cox, J.S., Shamu, C.E., and Walter, P. (1993). Transcriptional induction of genes encoding endoplasmic reticulum resident proteins requires a transmembrane protein kinase. *Cell* **73**, 1197-1206.
- Cox, J.S., and Walter, P. (1996). A novel mechanism for regulating activity of a transcription factor that controls the unfolded protein response. *Cell* **87**, 391-404.
- Cullen, P.J., Schultz, J., Horecka, J., Stevenson, B.J., Jigami, Y., and Sprague, G.F., Jr. (2000). Defects in protein glycosylation cause SHO1-dependent activation of a STE12 signaling pathway in yeast. *Genetics* **155**, 1005-1018.

## D

- Davenport, K.D., Williams, K.E., Ullmann, B.D., and Gustin, M.C. (1999). Activation of the *Saccharomyces cerevisiae* filamentation/invasion pathway by osmotic stress in high-osmolarity glycogen pathway mutants. *Genetics* **153**, 1091-1103.
- Davenport, K.R., Sohaskey, M., Kamada, Y., Levin, D.E., and Gustin, M.C. (1995). A second osmosensing signal transduction pathway in yeast. Hypotonic shock activates the PKC1 protein kinase-regulated cell integrity pathway. *The Journal of Biological Chemistry* **270**, 30157-30161.
- de Nadal, E., Casadomé, L., and Posas, F. (2003). Targeting the MEF2-like transcription factor Smp1 by the stress-activated Hog1 mitogen-activated protein kinase. *Molecular and Cellular Biology* **23**, 229-237.
- De Nadal, E., Zapater, M., Alepuz, P.M., Sumoy, L., Mas, G., and Posas, F. (2004). The MAPK Hog1 recruits Rpd3 histone deacetylase to activate osmoreponsive genes. *Nature* **427**, 370-374.
- Deckert, J., and Struhl, K. (2001). Histone acetylation at promoters is differentially affected by specific activators and repressors. *Molecular and Cellular Biology* **21**, 2726-2735.
- Dehe, P.M., and Geli, V. (2006). The multiple faces of Set1. *Biochemistry and cell biology = Biochimie et biologie cellulaire* **84**, 536-548.
- DeLange, R.J., Fambrough, D.M., Smith, E.L., and Bonner, J. (1969). Calf and pea histone IV. II. The complete amino acid sequence of calf thymus histone IV; presence of epsilon-N-acetyllysine. *The Journal of Biological Chemistry* **244**, 319-334.
- Dodou, E., and Treisman, R. (1997). The *Saccharomyces cerevisiae* MADS-box transcription factor Rlm1 is a target for the Mpk1 mitogen-activated protein kinase pathway. *Molecular and Cellular Biology* **17**, 1848-1859.
- Donati, G., Imbriano, C., and Mantovani, R. (2006). Dynamic recruitment of transcription factors and epigenetic changes on the ER stress response gene promoters. *Nucleic Acids Research* **34**, 3116-3127.
- Dora, E.G., Rudin, N., Martell, J.R., Esposito, M.S., and Ramirez, R.M. (1999). RPD3 (REC3) mutations affect mitotic recombination in *Saccharomyces cerevisiae*. *Current genetics* **35**, 68-76.

**E**

- Eberharter, A., Sterner, D.E., Schieltz, D., Hassan, A., Yates, J.R., 3rd, Berger, S.L., and Workman, J.L. (1999). The ADA complex is a distinct histone acetyltransferase complex in *Saccharomyces cerevisiae*. *Molecular and Cellular Biology* **19**, 6621-6631.
- Eisen, A., Utley, R.T., Nourani, A., Allard, S., Schmidt, P., Lane, W.S., Lucchesi, J.C., and Côté, J. (2001). The yeast NuA4 and Drosophila MSL complexes contain homologous subunits important for transcription regulation. *The Journal of Biological Chemistry* **276**, 3484-3491.
- Eisenmann, D.M., Arndt, K.M., Ricupero, S.L., Rooney, J.W., and Winston, F. (1992). SPT3 interacts with TFIID to allow normal transcription in *Saccharomyces cerevisiae*. *Genes & Development* **6**, 1319-1331.
- Elsaesser, S.J., Goldberg, A.D., and Allis, C.D. (2010). New functions for an old variant: no substitute for histone H3.3. *Current opinion in Genetics & Development* **20**, 110-117.
- Engin, F., and Hotamisligil, G.S. (2010). Restoring endoplasmic reticulum function by chemical chaperones: an emerging therapeutic approach for metabolic diseases. *Diabetes, obesity & metabolism* **12 Suppl 2**, 108-115.

**F**

- Felsenfeld, G., and Groudine, M. (2003). Controlling the double helix. *Nature* **421**, 448-453.
- Fernandez-Capetillo, O., Lee, A., Nussenzweig, M., and Nussenzweig, A. (2004). H2AX: the histone guardian of the genome. *DNA repair* **3**, 959-967.
- Ferrigno, P., Posas, F., Koepp, D., Saito, H., and Silver, P.A. (1998). Regulated nucleo/cytoplasmic exchange of HOG1 MAPK requires the importin beta homologs NMD5 and XPO1. *The EMBO Journal* **17**, 5606-5614.
- Fischle, W., Wang, Y., and Allis, C.D. (2003). Binary switches and modification cassettes in histone biology and beyond. *Nature* **425**, 475-479.
- Fischle, W., Wang, Y., Jacobs, S.A., Kim, Y., Allis, C.D., and Khorasanizadeh, S. (2003). Molecular basis for the discrimination of repressive methyl-lysine marks in histone H3 by Polycomb and HP1 chromodomains. *Genes & Development* **17**, 1870-1881.
- Flattery-O'Brien, J., Collinson, L.P., and Dawes, I.W. (1993). *Saccharomyces cerevisiae* has an inducible response to menadione which differs from that to hydrogen peroxide. *Journal of general microbiology* **139**, 501-507.
- Fletcher, T.M., and Hansen, J.C. (1995). Core histone tail domains mediate oligonucleosome folding and nucleosomal DNA organization through distinct molecular mechanisms. *The Journal of Biological Chemistry* **270**, 25359-25362.
- Forsberg, H., and Ljungdahl, P.O. (2001). Sensors of extracellular nutrients in *Saccharomyces cerevisiae*. *Current genetics* **40**, 91-109.

- Freemont, P.S., Hanson, I.M., and Trowsdale, J. (1991). A novel cysteine-rich sequence motif. *Cell* **64**, 483-484.
- Friedlander, G., Joseph-Strauss, D., Carmi, M., Zenvirth, D., Simchen, G., and Barkai, N. (2006). Modulation of the transcription regulatory program in yeast cells committed to sporulation. *Genome Biology* **7**, R20.
- Friedlander, R., Jarosch, E., Urban, J., Volkwein, C., and Sommer, T. (2000). A regulatory link between ER-associated protein degradation and the unfolded-protein response. *Nature Cell Biology* **2**, 379-384.
- Fuchs, B.B., and Mylonakis, E. (2009). Our paths might cross: the role of the fungal cell wall integrity pathway in stress response and cross talk with other stress response pathways. *Eukaryotic cell* **8**, 1616-1625.
- Fukuda, H., Sano, N., Muto, S., and Horikoshi, M. (2006). Simple histone acetylation plays a complex role in the regulation of gene expression. *Briefings in functional genomics & proteomics* **5**, 190-208.
- Futagami, T., Nakao, S., Kido, Y., Oka, T., Kajiwara, Y., Takashita, H., Omori, T., Furukawa, K., and Goto, M. (2011). Putative Stress Sensors WscA and WscB Are Involved in Hypo-Osmotic and Acidic pH Stress Tolerance in *Aspergillus nidulans*. *Eukaryotic cell* **10**, 1504-1515.

## G

- Gailus-Durner, V., Xie, J., Chintamaneni, C., and Vershon, A.K. (1996). Participation of the yeast activator Abf1 in meiosis-specific expression of the HOP1 gene. *Molecular and Cellular Biology* **16**, 2777-2786.
- Gancedo, J.M. (1998). Yeast carbon catabolite repression. *Microbiology and Molecular Biology Reviews* : MMBR **62**, 334-361.
- Gao, L., and Gross, D.S. (2008). Sir2 silences gene transcription by targeting the transition between RNA polymerase II initiation and elongation. *Molecular and Cellular Biology* **28**, 3979-3994.
- Garcia, R., Rodriguez-Pena, J.M., Bermejo, C., Nombela, C., and Arroyo, J. (2009). The high osmotic response and cell wall integrity pathways cooperate to regulate transcriptional responses to zymolyase-induced cell wall stress in *Saccharomyces cerevisiae*. *The Journal of Biological Chemistry* **284**, 10901-10911.
- Gardarin, A., Chedin, S., Lagniel, G., Aude, J.C., Godat, E., Catty, P., and Labarre, J. (2010). Endoplasmic reticulum is a major target of cadmium toxicity in yeast. *Molecular Microbiology* **76**, 1034-1048.
- Gardner, B.M., and Walter, P. (2011). Unfolded proteins are Ire1-activating ligands that directly induce the unfolded protein response. *Science* **333**, 1891-1894.
- Garrett-Engele, P., Moilanen, B., and Cyert, M.S. (1995). Calcineurin, the Ca<sup>2+</sup>/calmodulin-dependent protein phosphatase, is essential in yeast mutants with cell integrity defects and in mutants that lack a functional vacuolar H(+)-ATPase. *Molecular and Cellular Biology* **15**, 4103-4114.
- Gasch, A.P., Spellman, P.T., Kao, C.M., Carmel-Harel, O., Eisen, M.B., Storz, G., Botstein, D., and Brown, P.O. (2000). Genomic expression programs in the response of yeast cells to environmental changes. *Molecular Biology of the Cell* **11**, 4241-4257.
- Gaxiola, R., de Larrinoa, I.F., Villalba, J.M., and Serrano, R. (1992). A novel and conserved salt-induced protein is an important determinant of salt tolerance in yeast. *The EMBO Journal* **11**, 3157-3164.



- Georgakopoulos, T., and Thireos, G. (1992). Two distinct yeast transcriptional activators require the function of the GCN5 protein to promote normal levels of transcription. *The EMBO Journal* **11**, 4145-4152.
- Gietz, R.D., and Schiestl, R.H. (1991). Applications of high efficiency lithium acetate transformation of intact yeast cells using single-stranded nucleic acids as carrier. *Yeast* **7**, 253-263.
- Gimeno, C.J., Ljungdahl, P.O., Styles, C.A., and Fink, G.R. (1992). Unipolar cell divisions in the yeast *S. cerevisiae* lead to filamentous growth: regulation by starvation and RAS. *Cell* **68**, 1077-1090.
- Glozak, M.A., Sengupta, N., Zhang, X., and Seto, E. (2005). Acetylation and deacetylation of non-histone proteins. *Gene* **363**, 15-23.
- Goldmark, J.P., Fazio, T.G., Estep, P.W., Church, G.M., and Tsukiyama, T. (2000). The Isw2 chromatin remodeling complex represses early meiotic genes upon recruitment by Ume6p. *Cell* **103**, 423-433.
- Goldstein, A.L., and McCusker, J.H. (1999). Three new dominant drug resistance cassettes for gene disruption in *Saccharomyces cerevisiae*. *Yeast* **15**, 1541-1553.
- Govind, C.K., Qiu, H., Ginsburg, D.S., Ruan, C., Hofmeyer, K., Hu, C., Swaminathan, V., Workman, J.L., Li, B., and Hinnebusch, A.G. (2010). Phosphorylated Pol II CTD recruits multiple HDACs, including Rpd3C(S), for methylation-dependent deacetylation of ORF nucleosomes. *Molecular Cell* **39**, 234-246.
- Grant, P.A., Duggan, L., Côté, J., Roberts, S.M., Brownell, J.E., Candau, R., Ohba, R., Owen-Hughes, T., Allis, C.D., Winston, F., *et al.* (1997). Yeast Gcn5 functions in two multisubunit complexes to acetylate nucleosomal histones: characterization of an Ada complex and the SAGA (Spt/Ada) complex. *Genes & Development* **11**, 1640-1650.
- Grant, P.A., Eberharter, A., John, S., Cook, R.G., Turner, B.M., and Workman, J.L. (1999). Expanded lysine acetylation specificity of Gcn5 in native complexes. *The Journal of Biological Chemistry* **274**, 5895-5900.
- Gray, J.V., Ogas, J.P., Kamada, Y., Stone, M., Levin, D.E., and Herskowitz, I. (1997). A role for the Pkc1 MAP kinase pathway of *Saccharomyces cerevisiae* in bud emergence and identification of a putative upstream regulator. *The EMBO Journal* **16**, 4924-4937.
- Gregoretto, I.V., Lee, Y.M., and Goodson, H.V. (2004). Molecular evolution of the histone deacetylase family: functional implications of phylogenetic analysis. *Journal of molecular biology* **338**, 17-31.
- Groenendyk, J., Sreenivasaiah, P.K., Kim do, H., Agellon, L.B., and Michalak, M. (2010). Biology of endoplasmic reticulum stress in the heart. *Circulation research* **107**, 1185-1197.
- Grozinger, C.M., and Schreiber, S.L. (2002). Deacetylase enzymes: biological functions and the use of small-molecule inhibitors. *Chemistry & biology* **9**, 3-16.
- Guillemette, B., Drogaris, P., Lin, H.H., Armstrong, H., Hiragami-Hamada, K., Imhof, A., Bonneil, E., Thibault, P., Verreault, A., and Festenstein, R.J. (2011). H3 lysine 4 is acetylated at active gene promoters and is regulated by H3 lysine 4 methylation. *PLoS Genetics* **7**, e1001354.
- Gustin, M.C., Albertyn, J., Alexander, M., and Davenport, K. (1998). MAP kinase pathways in the yeast *Saccharomyces cerevisiae*. *Microbiology and Molecular Biology Reviews* : MMBR **62**, 1264-1300.

- Haberland, M., Montgomery, R.L., and Olson, E.N. (2009). The many roles of histone deacetylases in development and physiology: implications for disease and therapy. *Nature reviews Genetics* **10**, 32-42.
- Hahn, J.S., and Thiele, D.J. (2002). Regulation of the *Saccharomyces cerevisiae* Slt2 kinase pathway by the stress-inducible Sdp1 dual specificity phosphatase. *The Journal of Biological Chemistry* **277**, 21278-21284.
- Harding, H.P., Zhang, Y., and Ron, D. (1999). Protein translation and folding are coupled by an endoplasmic-reticulum-resident kinase. *Nature* **397**, 271-274.
- Harrison, J.C., Bardes, E.S., Ohya, Y., and Lew, D.J. (2001). A role for the Pkc1p/Mpk1p kinase cascade in the morphogenesis checkpoint. *Nature Cell Biology* **3**, 417-420.
- Hartzog, G.A., and Winston, F. (1997). Nucleosomes and transcription: recent lessons from genetics. *Current opinion in Genetics & Development* **7**, 192-198.
- Hassan, A.H., Awad, S., and Prochasson, P. (2006). The Swi2/Snf2 bromodomain is required for the displacement of SAGA and the octamer transfer of SAGA-acetylated nucleosomes. *The Journal of Biological Chemistry* **281**, 18126-18134.
- Hassan, A.H., Prochasson, P., Neely, K.E., Galasinski, S.C., Chandy, M., Carrozza, M.J., and Workman, J.L. (2002). Function and selectivity of bromodomains in anchoring chromatin-modifying complexes to promoter nucleosomes. *Cell* **111**, 369-379.
- Hassig, C.A., and Schreiber, S.L. (1997). Nuclear histone acetylases and deacetylases and transcriptional regulation: HATs off to HDACs. *Current opinion in chemical biology* **1**, 300-308.
- Haze, K., Yoshida, H., Yanagi, H., Yura, T., and Mori, K. (1999). Mammalian transcription factor ATF6 is synthesized as a transmembrane protein and activated by proteolysis in response to endoplasmic reticulum stress. *Molecular Biology of the Cell* **10**, 3787-3799.
- Hebbes, T.R., Thorne, A.W., Clayton, A.L., and Crane-Robinson, C. (1992). Histone acetylation and globin gene switching. *Nucleic Acids Research* **20**, 1017-1022.
- Heinisch, J.J., Lorberg, A., Schmitz, H.P., and Jacoby, J.J. (1999). The protein kinase C-mediated MAP kinase pathway involved in the maintenance of cellular integrity in *Saccharomyces cerevisiae*. *Molecular Microbiology* **32**, 671-680.
- Heinzel, T., Lavinsky, R.M., Mullen, T.M., Söderstrom, M., Laherty, C.D., Torchia, J., Yang, W.M., Brard, G., Ngo, S.D., Davie, J.R., *et al.* (1997). A complex containing N-CoR, mSin3 and histone deacetylase mediates transcriptional repression. *Nature* **387**, 43-48.
- Helliwell, S.B., Schmidt, A., Ohya, Y., and Hall, M.N. (1998). The Rho1 effector Pkc1, but not Bni1, mediates signalling from Tor2 to the actin cytoskeleton. *Current biology : CB* **8**, 1211-1214.
- Henry, K.A., Blank, H.M., Hoose, S.A., and Polymenis, M. (2010). The unfolded protein response is not necessary for the G1/S transition, but it is required for chromosome maintenance in *Saccharomyces cerevisiae*. *PLoS One* **5**, e12732.
- Hetz, C., Bernasconi, P., Fisher, J., Lee, A.H., Bassik, M.C., Antonsson, B., Brandt, G.S., Iwakoshi, N.N., Schinzel, A., Glimcher, L.H., *et al.* (2006). Proapoptotic BAX and BAK modulate the unfolded protein response by a direct interaction with IRE1alpha. *Science* **312**, 572-576.

- Hinnebusch, A.G. (1997). Translational regulation of yeast GCN4. A window on factors that control initiator-trna binding to the ribosome. *The Journal of Biological Chemistry* **272**, 21661-21664.
- Hirasawa, T., Ashitani, K., Yoshikawa, K., Nagahisa, K., Furusawa, C., Katakura, Y., Shimizu, H., and Shioya, S. (2006). Comparison of transcriptional responses to osmotic stresses induced by NaCl and sorbitol additions in *Saccharomyces cerevisiae* using DNA microarray. *Journal of bioscience and bioengineering* **102**, 568-571.
- Hodawadekar, S.C., and Marmorstein, R. (2007). Chemistry of acetyl transfer by histone modifying enzymes: structure, mechanism and implications for effector design. *Oncogene* **26**, 5528-5540.
- Hohmann, S. (2002). Osmotic stress signaling and osmoadaptation in yeasts. *Microbiology and Molecular Biology Reviews : MMBR* **66**, 300-372.
- Hohmann, S. (2009). Control of high osmolarity signalling in the yeast *Saccharomyces cerevisiae*. *FEBS letters* **583**, 4025-4029.
- Hohmann, S., Krantz, M., and Nordlander, B. (2007). Yeast osmoregulation. *Methods in Enzymology* **428**, 29-45.
- Hollien, J., Lin, J.H., Li, H., Stevens, N., Walter, P., and Weissman, J.S. (2009). Regulated Ire1-dependent decay of messenger RNAs in mammalian cells. *The Journal of Cell Biology* **186**, 323-331.
- Holst, B., Lunde, C., Lages, F., Oliveira, R., Lucas, C., and Kielland-Brandt, M.C. (2000). GUP1 and its close homologue GUP2, encoding multimembrane-spanning proteins involved in active glycerol uptake in *Saccharomyces cerevisiae*. *Molecular Microbiology* **37**, 108-124.
- Hori, O., Ichinoda, F., Yamaguchi, A., Tamatani, T., Taniguchi, M., Koyama, Y., Katayama, T., Tohyama, M., Stern, D.M., Ozawa, K., *et al.* (2004). Role of Herp in the endoplasmic reticulum stress response. *Genes to cells : devoted to molecular & cellular mechanisms* **9**, 457-469.
- Howe, L., Auston, D., Grant, P., John, S., Cook, R.G., Workman, J.L., and Pillus, L. (2001). Histone H3 specific acetyltransferases are essential for cell cycle progression. *Genes & Development* **15**, 3144-3154.
- Huang, L., Sun, Q., Qin, F., Li, C., Zhao, Y., and Zhou, D.X. (2007). Down-regulation of a SILENT INFORMATION REGULATOR2-related histone deacetylase gene, OsSRT1, induces DNA fragmentation and cell death in rice. *Plant physiology* **144**, 1508-1519.
- Hudson, B.P., Martinez-Yamout, M.A., Dyson, H.J., and Wright, P.E. (2000). Solution structure and acetyl-lysine binding activity of the GCN5 bromodomain. *Journal of molecular biology* **304**, 355-370.
- Huh, W.K., Falvo, J.V., Gerke, L.C., Carroll, A.S., Howson, R.W., Weissman, J.S., and O'Shea, E.K. (2003). Global analysis of protein localization in budding yeast. *Nature* **425**, 686-691.
- Hurtley, S.M., and Helenius, A. (1989). Protein oligomerization in the endoplasmic reticulum. *Annual review of cell biology* **5**, 277-307.
- I
- Iwakoshi, N.N., Lee, A.H., Vallabhajosyula, P., Otipoby, K.L., Rajewsky, K., and Glimcher, L.H. (2003). Plasma cell differentiation and the unfolded protein response intersect at the transcription factor XBP-1. *Nature immunology* **4**, 321-329.

**J**

- Jacobs, S.A., and Khorasanizadeh, S. (2002). Structure of HP1 chromodomain bound to a lysine 9-methylated histone H3 tail. *Science* **295**, 2080-2083.
- Jamieson, D.J. (1998). Oxidative stress responses of the yeast *Saccharomyces cerevisiae*. *Yeast* **14**, 1511-1527.
- Jämsä, E., Simonen, M., and Makarow, M. (1994). Selective retention of secretory proteins in the yeast endoplasmic reticulum by treatment of cells with a reducing agent. *Yeast* **10**, 355-370.
- Jeppesen, P., and Turner, B.M. (1993). The inactive X chromosome in female mammals is distinguished by a lack of histone H4 acetylation, a cytogenetic marker for gene expression. *Cell* **74**, 281-289.
- John, S., Howe, L., Tafrov, S.T., Grant, P.A., Sternglanz, R., and Workman, J.L. (2000). The something about silencing protein, Sas3, is the catalytic subunit of NuA3, a  $\gamma$ TAF(II)30-containing HAT complex that interacts with the Spt16 subunit of the yeast CP (Cdc68/Pob3)-FACT complex. *Genes & Development* **14**, 1196-1208.
- Johnsson, A., Durand-Dubief, M., Xue-Franzén, Y., Rönnerblad, M., Ekwall, K., and Wright, A. (2009). HAT-HDAC interplay modulates global histone H3K14 acetylation in gene-coding regions during stress. *EMBO Reports* **10**, 1009-1014.
- Johnsson, A.E., and Wright, A.P. (2010). The role of specific HAT-HDAC interactions in transcriptional elongation. *Cell Cycle* **9**, 467-471.
- Jung, U.S., and Levin, D.E. (1999). Genome-wide analysis of gene expression regulated by the yeast cell wall integrity signalling pathway. *Molecular Microbiology* **34**, 1049-1057.
- Jung, U.S., Sobering, A.K., Romeo, M.J., and Levin, D.E. (2002). Regulation of the yeast Rlm1 transcription factor by the Mpk1 cell wall integrity MAP kinase. *Molecular Microbiology* **46**, 781-789.

**K**

- Kadosh, D., and Struhl, K. (1997). Repression by Ume6 involves recruitment of a complex containing Sin3 corepressor and Rpd3 histone deacetylase to target promoters. *Cell* **89**, 365-371.
- Kamada, Y., Qadota, H., Python, C.P., Anraku, Y., Ohya, Y., and Levin, D.E. (1996). Activation of yeast protein kinase C by Rho1 GTPase. *The Journal of Biological Chemistry* **271**, 9193-9196.
- Kamakaka, R.T., and Biggins, S. (2005). Histone variants: deviants? *Genes & Development* **19**, 295-310.
- Karlgren, S., Pettersson, N., Nordlander, B., Mathai, J.C., Brodsky, J.L., Zeidel, M.L., Bill, R.M., and Hohmann, S. (2005). Conditional osmotic stress in yeast: a system to study transport through aquaglyceroporins and osmostress signaling. *The Journal of Biological Chemistry* **280**, 7186-7193.

- Kasten, M.M., Dorland, S., and Stillman, D.J. (1997). A large protein complex containing the yeast Sin3p and Rpd3p transcriptional regulators. *Molecular and Cellular Biology* **17**, 4852-4858.
- Kawahara, T., Yanagi, H., Yura, T., and Mori, K. (1997). Endoplasmic reticulum stress-induced mRNA splicing permits synthesis of transcription factor Hac1p/Ern4p that activates the unfolded protein response. *Molecular Biology of the Cell* **8**, 1845-1862.
- Kayne, P.S., Kim, U.J., Han, M., Mullen, J.R., Yoshizaki, F., and Grunstein, M. (1988). Extremely conserved histone H4 N terminus is dispensable for growth but essential for repressing the silent mating loci in yeast. *Cell* **55**, 27-39.
- Keogh, M.C., Kurdistani, S.K., Morris, S.A., Ahn, S.H., Podolny, V., Collins, S.R., Schuldiner, M., Chin, K., Punna, T., Thompson, N.J., *et al.* (2005). Cotranscriptional set2 methylation of histone H3 lysine 36 recruits a repressive Rpd3 complex. *Cell* **123**, 593-605.
- Ketela, T., Brown, J.L., Stewart, R.C., and Bussey, H. (1998). Yeast Skn7p activity is modulated by the Sln1p-Ypd1p osmosensor and contributes to regulation of the HOG pathway. *Molecular & general genetics : MGG* **259**, 372-378.
- Ketela, T., Green, R., and Bussey, H. (1999). *Saccharomyces cerevisiae* mid2p is a potential cell wall stress sensor and upstream activator of the PKC1-MPK1 cell integrity pathway. *Journal of bacteriology* **181**, 3330-3340.
- Keyse, S.M. (2000). Protein phosphatases and the regulation of mitogen-activated protein kinase signalling. *Current opinion in cell biology* **12**, 186-192.
- Khochbin, S., Verdel, A., Lemerrier, C., and Seigneurin-Berny, D. (2001). Functional significance of histone deacetylase diversity. *Current opinion in Genetics & Development* **11**, 162-166.
- Kiely, C.M., Marguerat, S., Garcia, J.F., Madhani, H.D., Bahler, J., and Winston, F. (2011). Spt6 is required for heterochromatic silencing in the fission yeast *Schizosaccharomyces pombe*. *Molecular and cellular biology* **31**, 4193-4204.
- Kim, S.C., Sprung, R., Chen, Y., Xu, Y., Ball, H., Pei, J., Cheng, T., Kho, Y., Xiao, H., Xiao, L., *et al.* (2006). Substrate and functional diversity of lysine acetylation revealed by a proteomics survey. *Molecular Cell* **23**, 607-618.
- Kleff, S., Andrulis, E.D., Anderson, C.W., and Sternglanz, R. (1995). Identification of a gene encoding a yeast histone H4 acetyltransferase. *The Journal of Biological Chemistry* **270**, 24674-24677.
- Kobayashi, N., and McEntee, K. (1990). Evidence for a heat shock transcription factor-independent mechanism for heat shock induction of transcription in *Saccharomyces cerevisiae*. *Proceedings of the National Academy of Sciences of the United States of America* **87**, 6550-6554.
- Kobayashi, N., and McEntee, K. (1993). Identification of cis and trans components of a novel heat shock stress regulatory pathway in *Saccharomyces cerevisiae*. *Molecular and Cellular Biology* **13**, 248-256.
- Korennykh, A.V., Egea, P.F., Korostelev, A.A., Finer-Moore, J., Zhang, C., Shokat, K.M., Stroud, R.M., and Walter, P. (2009). The unfolded protein response signals through high-order assembly of Ire1. *Nature* **457**, 687-693.
- Korennykh, A.V., Korostelev, A.A., Egea, P.F., Finer-Moore, J., Stroud, R.M., Zhang, C., Shokat, K.M., and Walter, P. (2011). Structural and functional basis for RNA cleavage by Ire1. *BMC biology* **9**, 47.
- Kornberg, R.D. (1974). Chromatin structure: a repeating unit of histones and DNA. *Science* **184**, 868-871.

- Kouzarides, T. (2000). Acetylation: a regulatory modification to rival phosphorylation? *The EMBO Journal* **19**, 1176-1179.
- Kremer, S.B., and Gross, D.S. (2009). SAGA and Rpd3 chromatin modification complexes dynamically regulate heat shock gene structure and expression. *The Journal of Biological Chemistry* **284**, 32914-32931.
- Krogan, N.J., Baetz, K., Keogh, M.C., Datta, N., Sawa, C., Kwok, T.C., Thompson, N.J., Davey, M.G., Pootoolal, J., Hughes, T.R., *et al.* (2004). Regulation of chromosome stability by the histone H2A variant Htz1, the Swr1 chromatin remodeling complex, and the histone acetyltransferase NuA4. *Proceedings of the National Academy of Sciences of the United States of America* **101**, 13513-13518.
- Krysan, D.J. (2009). The cell wall and endoplasmic reticulum stress responses are coordinately regulated in *Saccharomyces cerevisiae*. *Communicative & integrative biology* **2**, 233-235.
- Kuo, M.H., and Allis, C.D. (1998). Roles of histone acetyltransferases and deacetylases in gene regulation. *BioEssays : news and reviews in molecular, cellular and developmental biology* **20**, 615-626.
- Kuo, M.H., Zhou, J., Jambeck, P., Churchill, M.E., and Allis, C.D. (1998). Histone acetyltransferase activity of yeast Gcn5p is required for the activation of target genes in vivo. *Genes & Development* **12**, 627-639.
- Kuo, S.C., and Lampen, J.O. (1974). Tunicamycin--an inhibitor of yeast glycoprotein synthesis. *Biochemical and Biophysical Research Communications* **58**, 287-295.
- Kupiec, M., Byers, B., Esposito, R.E. and Mitchell, A.P. (1997). Meiosis and sporulation in *Saccharomyces cerevisiae*. In Pringle, J.R., Broach, J.R. and Jones, E.W. (eds.), *The Molecular and Cellular Biology of the Yeast Saccharomyces*. Cold Spring Harbor Laboratory Press, Plainview, N.Y., **3**, 889-1036.
- Kurdistani, S.K., Robyr, D., Tavazoie, S., and Grunstein, M. (2002). Genome-wide binding map of the histone deacetylase Rpd3 in yeast. *Nature genetics* **31**, 248-254.
- L**
- Lages, F., Silva-Graca, M., and Lucas, C. (1999). Active glycerol uptake is a mechanism underlying halotolerance in yeasts: a study of 42 species. *Microbiology* **145 ( Pt 9)**, 2577-2585.
- Lagorce, A., Hauser, N.C., Labourdette, D., Rodriguez, C., Martin-Yken, H., Arroyo, J., Hoheisel, J.D., and Francois, J. (2003). Genome-wide analysis of the response to cell wall mutations in the yeast *Saccharomyces cerevisiae*. *The Journal of Biological Chemistry* **278**, 20345-20357.
- Laherty, C.D., Yang, W.M., Sun, J.M., Davie, J.R., Seto, E., and Eisenman, R.N. (1997). Histone deacetylases associated with the mSin3 corepressor mediate mad transcriptional repression. *Cell* **89**, 349-356.
- Lamitina, T., Huang, C.G., and Strange, K. (2006). Genome-wide RNAi screening identifies protein damage as a regulator of osmoprotective gene expression. *Proceedings of the National Academy of Sciences of the United States of America* **103**, 12173-12178.
- Lamping, E., Luckl, J., Paltauf, F., Henry, S.A., and Kohlwein, S.D. (1994). Isolation and characterization of a mutant of *Saccharomyces cerevisiae* with pleiotropic deficiencies in transcriptional activation and repression. *Genetics* **137**, 55-65.
- Lan, F., and Shi, Y. (2009). Epigenetic regulation: methylation of histone and non-histone proteins. *Science in China Series C, Life sciences / Chinese Academy of Sciences* **52**, 311-322.

- Lechner, T., Carrozza, M.J., Yu, Y., Grant, P.A., Eberharter, A., Vannier, D., Brosch, G., Stillman, D.J., Shore, D., and Workman, J.L. (2000). Sds3 (suppressor of defective silencing 3) is an integral component of the yeast Sin3[middle dot]Rpd3 histone deacetylase complex and is required for histone deacetylase activity. *The Journal of Biological Chemistry* **275**, 40961-40966.
- Lee, A.H., Chu, G.C., Iwakoshi, N.N., and Glimcher, L.H. (2005). XBP-1 is required for biogenesis of cellular secretory machinery of exocrine glands. *The EMBO Journal* **24**, 4368-4380.
- Lee, A.H., Iwakoshi, N.N., and Glimcher, L.H. (2003). XBP-1 regulates a subset of endoplasmic reticulum resident chaperone genes in the unfolded protein response. *Molecular and Cellular Biology* **23**, 7448-7459.
- Lee, J., Godon, C., Lagniel, G., Spector, D., Garin, J., Labarre, J., and Toledano, M.B. (1999). Yap1 and Skn7 control two specialized oxidative stress response regulons in yeast. *The Journal of Biological Chemistry* **274**, 16040-16046.
- Lee, J.S., and Shilatifard, A. (2007). A site to remember: H3K36 methylation a mark for histone deacetylation. *Mutation research* **618**, 130-134.
- Lee, K.P., Dey, M., Neculai, D., Cao, C., Dever, T.E., and Sicheri, F. (2008). Structure of the dual enzyme Ire1 reveals the basis for catalysis and regulation in nonconventional RNA splicing. *Cell* **132**, 89-100.
- Lee, K.S., Irie, K., Gotoh, Y., Watanabe, Y., Araki, H., Nishida, E., Matsumoto, K., and Levin, D.E. (1993). A yeast mitogen-activated protein kinase homolog (Mpk1p) mediates signalling by protein kinase C. *Molecular and Cellular Biology* **13**, 3067-3075.
- Lenfant, F., Mann, R.K., Thomsen, B., Ling, X., and Grunstein, M. (1996). All four core histone N-termini contain sequences required for the repression of basal transcription in yeast. *The EMBO Journal* **15**, 3974-3985.
- Lengeler, K.B., Davidson, R.C., D'Souza, C., Harashima, T., Shen, W.C., Wang, P., Pan, X., Waugh, M., and Heitman, J. (2000). Signal transduction cascades regulating fungal development and virulence. *Microbiology and Molecular Biology Reviews* : MMBR **64**, 746-785.
- Lewis, J.G., Learmonth, R.P., and Watson, K. (1995). Induction of heat, freezing and salt tolerance by heat and salt shock in *Saccharomyces cerevisiae*. *Microbiology* **141 ( Pt 3)**, 687-694.
- Li, B., Gogol, M., Carey, M., Lee, D., Seidel, C., and Workman, J.L. (2007). Combined action of PHD and chromo domains directs the Rpd3S HDAC to transcribed chromatin. *Science* **316**, 1050-1054.
- Li, B., Gogol, M., Carey, M., Pattenden, S.G., Seidel, C., and Workman, J.L. (2007). Infrequently transcribed long genes depend on the Set2/Rpd3S pathway for accurate transcription. *Genes & Development* **21**, 1422-1430.
- Li, B., Yi, P., Zhang, B., Xu, C., Liu, Q., Pi, Z., Xu, X., Chevet, E., and Liu, J. (2011). Differences in endoplasmic reticulum stress signalling kinetics determine cell survival outcome through activation of MKP-1. *Cellular signalling* **23**, 35-45.
- Li, H., Korennykh, A.V., Behrman, S.L., and Walter, P. (2010). Mammalian endoplasmic reticulum stress sensor IRE1 signals by dynamic clustering. *Proceedings of the National Academy of Sciences of the United States of America* **107**, 16113-16118.
- Li, S., Ault, A., Malone, C.L., Raitt, D., Dean, S., Johnston, L.H., Deschenes, R.J., and Fassler, J.S. (1998). The yeast histidine protein kinase, Sln1p, mediates phosphotransfer to two response regulators, Ssk1p and Skn7p. *The EMBO Journal* **17**, 6952-6962.

- Li, S., Dean, S., Li, Z., Horecka, J., Deschenes, R.J., and Fassler, J.S. (2002). The eukaryotic two-component histidine kinase Sln1p regulates *OCH1* via the transcription factor, Skn7p. *Molecular Biology of the Cell* **13**, 412-424.
- Lin, K.I., Lin, Y., and Calame, K. (2000). Repression of c-myc is necessary but not sufficient for terminal differentiation of B lymphocytes in vitro. *Molecular and Cellular Biology* **20**, 8684-8695.
- Ling, X., Harkness, T.A., Schultz, M.C., Fisher-Adams, G., and Grunstein, M. (1996). Yeast histone H3 and H4 amino termini are important for nucleosome assembly in vivo and in vitro: redundant and position-independent functions in assembly but not in gene regulation. *Genes & Development* **10**, 686-699.
- Liu, C.Y., Xu, Z., and Kaufman, R.J. (2003). Structure and intermolecular interactions of the luminal dimerization domain of human IRE1alpha. *The Journal of Biological Chemistry* **278**, 17680-17687.
- Liu, J.X., Srivastava, R., Che, P., and Howell, S.H. (2007). An endoplasmic reticulum stress response in *Arabidopsis* is mediated by proteolytic processing and nuclear relocation of a membrane-associated transcription factor, bZIP28. *The Plant cell* **19**, 4111-4119.
- Liu, J.X., Srivastava, R., Che, P., and Howell, S.H. (2007). Salt stress responses in *Arabidopsis* utilize a signal transduction pathway related to endoplasmic reticulum stress signaling. *The Plant journal : for cell and molecular biology* **51**, 897-909.
- Liu, L., Cui, F., Li, Q., Yin, B., Zhang, H., Lin, B., Wu, Y., Xia, R., Tang, S., and Xie, Q. (2011). The endoplasmic reticulum-associated degradation is necessary for plant salt tolerance. *Cell research* **21**, 957-969.
- Liu, Y., and Chang, A. (2008). Heat shock response relieves ER stress. *The EMBO Journal* **27**, 1049-1059.
- Lo, W.S., Trievel, R.C., Rojas, J.R., Duggan, L., Hsu, J.Y., Allis, C.D., Marmorstein, R., and Berger, S.L. (2000). Phosphorylation of serine 10 in histone H3 is functionally linked in vitro and in vivo to Gcn5-mediated acetylation at lysine 14. *Molecular Cell* **5**, 917-926.
- Loewith, R., Smith, J.S., Meijer, M., Williams, T.J., Bachman, N., Boeke, J.D., and Young, D. (2001). Pho23 is associated with the Rpd3 histone deacetylase and is required for its normal function in regulation of gene expression and silencing in *Saccharomyces cerevisiae*. *The Journal of Biological Chemistry* **276**, 24068-24074.
- Lovering, R., Hanson, I.M., Borden, K.L., Martin, S., O'Reilly, N.J., Evan, G.I., Rahman, D., Pappin, D.J., Trowsdale, J., and Freemont, P.S. (1993). Identification and preliminary characterization of a protein motif related to the zinc finger. *Proceedings of the National Academy of Sciences of the United States of America* **90**, 2112-2116.
- Lowry, C.V., and Zitomer, R.S. (1984). Oxygen regulation of anaerobic and aerobic genes mediated by a common factor in yeast. *Proceedings of the National Academy of Sciences of the United States of America* **81**, 6129-6133.
- Lu, D.P., and Christopher, D.A. (2008). Endoplasmic reticulum stress activates the expression of a sub-group of protein disulfide isomerase genes and AtbZIP60 modulates the response in *Arabidopsis thaliana*. *Molecular genetics and genomics : MGG* **280**, 199-210.
- Lu, P.Y., Levesque, N., and Kobor, M.S. (2009). NuA4 and SWR1-C: two chromatin-modifying complexes with overlapping functions and components. *Biochemistry and cell biology = Biochimie et biologie cellulaire* **87**, 799-815.



Lu, Z., Scott, I., Webster, B.R., and Sack, M.N. (2009). The emerging characterization of lysine residue deacetylation on the modulation of mitochondrial function and cardiovascular biology. *Circulation research* **105**, 830-841.

Lucchini, G., Hinnebusch, A.G., Chen, C., and Fink, G.R. (1984). Positive regulatory interactions of the HIS4 gene of *Saccharomyces cerevisiae*. *Molecular and Cellular Biology* **4**, 1326-1333.

Luyten, K., Albertyn, J., Skibbe, W.F., Prior, B.A., Ramos, J., Thevelein, J.M., and Hohmann, S. (1995). Fps1, a yeast member of the MIP family of channel proteins, is a facilitator for glycerol uptake and efflux and is inactive under osmotic stress. *The EMBO Journal* **14**, 1360-1371.

## M

Ma, K., Vattem, K.M., and Wek, R.C. (2002). Dimerization and release of molecular chaperone inhibition facilitate activation of eukaryotic initiation factor-2 kinase in response to endoplasmic reticulum stress. *The Journal of Biological Chemistry* **277**, 18728-18735.

Madden, K., Sheu, Y.J., Baetz, K., Andrews, B., and Snyder, M. (1997). SBF cell cycle regulator as a target of the yeast PKC-MAP kinase pathway. *Science* **275**, 1781-1784.

Maeda, T., Wurgler-Murphy, S.M., and Saito, H. (1994). A two-component system that regulates an osmosensing MAP kinase cascade in yeast. *Nature* **369**, 242-245.

Mallory, M.J., and Strich, R. (2003). Ume1p represses meiotic gene transcription in *Saccharomyces cerevisiae* through interaction with the histone deacetylase Rpd3p. *The Journal of Biological Chemistry* **278**, 44727-44734.

Marchler, G., Schüller, C., Adam, G., and Ruis, H. (1993). A *Saccharomyces cerevisiae* UAS element controlled by protein kinase A activates transcription in response to a variety of stress conditions. *The EMBO Journal* **12**, 1997-2003.

Marini, N.J., Meldrum, E., Buehrer, B., Hubberstey, A.V., Stone, D.E., Traynor-Kaplan, A., and Reed, S.I. (1996). A pathway in the yeast cell division cycle linking protein kinase C (Pkc1) to activation of Cdc28 at START. *The EMBO Journal* **15**, 3040-3052.

Marks, P.A., Richon, V.M., Miller, T., and Kelly, W.K. (2004). Histone deacetylase inhibitors. *Advances in cancer research* **91**, 137-168.

Martínez-Montañés, F., Pascual-Ahuir, A., and Proft, M. (2010). Toward a genomic view of the gene expression program regulated by osmotic stress in yeast. *Omics : a journal of integrative biology* **14**, 619-627.

Martínez-Pastor, M.T., Marchler, G., Schüller, C., Marchler-Bauer, A., Ruis, H., and Estruch, F. (1996). The *Saccharomyces cerevisiae* zinc finger proteins Msn2p and Msn4p are required for transcriptional induction through the stress response element (STRE). *The EMBO Journal* **15**, 2227-2235.

Mas, G., de Nadal, E., Dechant, R., Rodríguez de la Concepción, M.L., Logie, C., Jimeno-González, S., Chávez, S., Ammerer, G., and Posas, F. (2009). Recruitment of a chromatin remodelling complex by the Hog1 MAP kinase to stress genes. *The EMBO Journal* **28**, 326-336.

Matsumoto, S., and Yanagida, M. (1985). Histone gene organization of fission yeast: a common upstream sequence. *The EMBO Journal* **4**, 3531-3538.

- McCullough, S.D., and Grant, P.A. (2010). Histone acetylation, acetyltransferases, and ataxia--alteration of histone acetylation and chromatin dynamics is implicated in the pathogenesis of polyglutamine-expansion disorders. *Advances in protein chemistry and structural biology* **79**, 165-203.
- Meersseman, G., Pennings, S., and Bradbury, E.M. (1992). Mobile nucleosomes--a general behavior. *The EMBO Journal* **11**, 2951-2959.
- Messmer, S., Franke, A., and Paro, R. (1992). Analysis of the functional role of the Polycomb chromo domain in *Drosophila melanogaster*. *Genes & Development* **6**, 1241-1254.
- Michishita, E., McCord, R.A., Berber, E., Kioi, M., Padilla-Nash, H., Damian, M., Cheung, P., Kusumoto, R., Kawahara, T.L., Barrett, J.C., *et al.* (2008). SIRT6 is a histone H3 lysine 9 deacetylase that modulates telomeric chromatin. *Nature* **452**, 492-496.
- Miller, C., Schwalb, B., Maier, K., Schulz, D., Dumcke, S., Zacher, B., Mayer, A., Sydow, J., Marcinowski, L., Dölken, L., *et al.* (2011). Dynamic transcriptome analysis measures rates of mRNA synthesis and decay in yeast. *Molecular systems biology* **7**, 458.
- Minucci, S., Nervi, C., Lo Coco, F., and Pelicci, P.G. (2001). Histone deacetylases: a common molecular target for differentiation treatment of acute myeloid leukemias? *Oncogene* **20**, 3110-3115.
- Mitchel, R.E., and Morrison, D.P. (1982). Heat-shock induction of ionizing radiation resistance in *Saccharomyces cerevisiae*, and correlation with stationary growth phase. *Radiation research* **90**, 284-291.
- Mitchell, A.P. (1994). Control of meiotic gene expression in *Saccharomyces cerevisiae*. *Microbiological reviews* **58**, 56-70.
- Moreno, A.A., and Orellana, A. (2011). The physiological role of the unfolded protein response in plants. *Biological research* **44**, 75-80.
- Mori, K., Kawahara, T., Yoshida, H., Yanagi, H., and Yura, T. (1996). Signalling from endoplasmic reticulum to nucleus: transcription factor with a basic-leucine zipper motif is required for the unfolded protein-response pathway. *Genes to cells : devoted to molecular & cellular mechanisms* **1**, 803-817.
- Mori, K., Ma, W., Gething, M.J., and Sambrook, J. (1993). A transmembrane protein with a *cdc2<sup>+</sup>/CDC28*-related kinase activity is required for signaling from the ER to the nucleus. *Cell* **74**, 743-756.
- Mori, K., Ogawa, N., Kawahara, T., Yanagi, H., and Yura, T. (1998). Palindrome with spacer of one nucleotide is characteristic of the cis-acting unfolded protein response element in *Saccharomyces cerevisiae*. *The Journal of Biological Chemistry* **273**, 9912-9920.
- Mori, K., Ogawa, N., Kawahara, T., Yanagi, H., and Yura, T. (2000). mRNA splicing-mediated C-terminal replacement of transcription factor Hac1p is required for efficient activation of the unfolded protein response. *Proceedings of the National Academy of Sciences of the United States of America* **97**, 4660-4665.
- Mori, K., Sant, A., Kohno, K., Normington, K., Gething, M.J., and Sambrook, J.F. (1992). A 22 bp cis-acting element is necessary and sufficient for the induction of the yeast *KAR2* (BIP) gene by unfolded proteins. *The EMBO Journal* **11**, 2583-2593.
- Mori, T., Ogasawara, C., Inada, T., Englert, M., Beier, H., Takezawa, M., Endo, T., and Yoshihisa, T. (2010). Dual functions of yeast tRNA ligase in the unfolded protein response: unconventional cytoplasmic splicing of *HAC1* pre-mRNA is not sufficient to release translational attenuation. *Molecular Biology of the Cell* **21**, 3722-3734.

- Morris, G.J., Winters, L., Coulson, G.E., and Clarke, K.J. (1986). Effect of osmotic stress on the ultrastructure and viability of the yeast *Saccharomyces cerevisiae*. *Journal of general microbiology* **132**, 2023-2034.
- Moskvina, E., Schüller, C., Maurer, C.T., Mager, W.H., and Ruis, H. (1998). A search in the genome of *Saccharomyces cerevisiae* for genes regulated via stress response elements. *Yeast* **14**, 1041-1050.
- Mujtaba, S., He, Y., Zeng, L., Farooq, A., Carlson, J.E., Ott, M., Verdin, E., and Zhou, M.M. (2002). Structural basis of lysine-acetylated HIV-1 Tat recognition by PCAF bromodomain. *Molecular Cell* **9**, 575-586.
- Mujtaba, S., Zeng, L., and Zhou, M.M. (2007). Structure and acetyl-lysine recognition of the bromodomain. *Oncogene* **26**, 5521-5527.

## N

- Nagy, L., Kao, H.Y., Chakravarti, D., Lin, R.J., Hassig, C.A., Ayer, D.E., Schreiber, S.L., and Evans, R.M. (1997). Nuclear receptor repression mediated by a complex containing SMRT, mSin3A, and histone deacetylase. *Cell* **89**, 373-380.
- Narlikar, G.J., Fan, H.Y., and Kingston, R.E. (2002). Cooperation between complexes that regulate chromatin structure and transcription. *Cell* **108**, 475-487.
- Ng, S.S., Yue, W.W., Oppermann, U., and Klose, R.J. (2009). Dynamic protein methylation in chromatin biology. *Cellular and molecular life sciences : CMLS* **66**, 407-422.
- Nickas, M.E., and Yaffe, M.P. (1996). *BRO1*, a novel gene that interacts with components of the Pkc1p-mitogen-activated protein kinase pathway in *Saccharomyces cerevisiae*. *Molecular and Cellular Biology* **16**, 2585-2593.
- Nielsen, P.R., Nietlispach, D., Mott, H.R., Callaghan, J., Bannister, A., Kouzarides, T., Murzin, A.G., Murzina, N.V., and Laue, E.D. (2002). Structure of the HP1 chromodomain bound to histone H3 methylated at lysine 9. *Nature* **416**, 103-107.
- Nishitoh, H., Matsuzawa, A., Tobiume, K., Saegusa, K., Takeda, K., Inoue, K., Hori, S., Kakizuka, A., and Ichijo, H. (2002). ASK1 is essential for endoplasmic reticulum stress-induced neuronal cell death triggered by expanded polyglutamine repeats. *Genes & Development* **16**, 1345-1355.
- Nonaka, H., Tanaka, K., Hirano, H., Fujiwara, T., Kohno, H., Umikawa, M., Mino, A., and Takai, Y. (1995). A downstream target of RHO1 small GTP-binding protein is PKC1, a homolog of protein kinase C, which leads to activation of the MAP kinase cascade in *Saccharomyces cerevisiae*. *The EMBO Journal* **14**, 5931-5938.
- Norbeck, J., and Blomberg, A. (1998). Amino acid uptake is strongly affected during exponential growth of *Saccharomyces cerevisiae* in 0.7 M NaCl medium. *FEMS microbiology letters* **158**, 121-126.
- Norbeck, J., and Blomberg, A. (2000). The level of cAMP-dependent protein kinase A activity strongly affects osmotolerance and osmo-instigated gene expression changes in *Saccharomyces cerevisiae*. *Yeast* **16**, 121-137.

## O

- Oda, H., Okamoto, I., Murphy, N., Chu, J., Price, S.M., Shen, M.M., Torres-Padilla, M.E., Heard, E., and Reinberg, D. (2009). Monomethylation of histone H4-lysine 20 is involved in chromosome structure and stability and is essential for mouse development. *Molecular and Cellular Biology* **29**, 2278-2295.
- Oki, M., Aihara, H., and Ito, T. (2007). Role of histone phosphorylation in chromatin dynamics and its implications in diseases. *Sub-cellular biochemistry* **41**, 319-336.
- Oliveira, R., Lages, F., Silva-Graca, M., and Lucas, C. (2003). Fps1p channel is the mediator of the major part of glycerol passive diffusion in *Saccharomyces cerevisiae*: artefacts and re-definitions. *Biochimica et biophysica acta* **1613**, 57-71.
- Ostrander, D.B., and Gorman, J.A. (1999). The extracellular domain of the *Saccharomyces cerevisiae* Sln1p membrane osmolarity sensor is necessary for kinase activity. *Journal of bacteriology* **181**, 2527-2534.
- Ota, I.M., and Varshavsky, A. (1993). A yeast protein similar to bacterial two-component regulators. *Science* **262**, 566-569.
- Owen, D.J., Ornaghi, P., Yang, J.C., Lowe, N., Evans, P.R., Ballario, P., Neuhaus, D., Filetici, P., and Travers, A.A. (2000). The structural basis for the recognition of acetylated histone H4 by the bromodomain of histone acetyltransferase gcn5p. *The EMBO Journal* **19**, 6141-6149.
- Ozaki, K., Tanaka, K., Imamura, H., Hihara, T., Kameyama, T., Nonaka, H., Hirano, H., Matsuura, Y., and Takai, Y. (1996). Rom1p and Rom2p are GDP/GTP exchange proteins (GEPs) for the Rho1p small GTP binding protein in *Saccharomyces cerevisiae*. *The EMBO Journal* **15**, 2196-2207.
- P**
- Pal, B., Chan, N.C., Helfenbaum, L., Tan, K., Tansey, W.P., and Gething, M.J. (2007). SCF<sup>Cdc4</sup>-mediated degradation of the Hac1p transcription factor regulates the unfolded protein response in *Saccharomyces cerevisiae*. *Molecular Biology of the Cell* **18**, 426-440.
- Pandey, R., Muller, A., Napoli, C.A., Selinger, D.A., Pikaard, C.S., Richards, E.J., Bender, J., Mount, D.W., and Jorgensen, R.A. (2002). Analysis of histone acetyltransferase and histone deacetylase families of *Arabidopsis thaliana* suggests functional diversification of chromatin modification among multicellular eukaryotes. *Nucleic Acids Research* **30**, 5036-5055.
- Parthun, M.R. (2007). Hat1: the emerging cellular roles of a type B histone acetyltransferase. *Oncogene* **26**, 5319-5328.
- Pascual-Ahuir, A., Serrano, R., and Proft, M. (2001). The Sko1p repressor and Gcn4p activator antagonistically modulate stress-regulated transcription in *Saccharomyces cerevisiae*. *Molecular and Cellular Biology* **21**, 16-25.
- Pastor, M.M., Proft, M., and Pascual-Ahuir, A. (2009). Mitochondrial function is an inducible determinant of osmotic stress adaptation in yeast. *The Journal of Biological Chemistry* **284**, 30307-30317.
- Patel, J., Pathak, R.R., and Mujtaba, S. (2011). The biology of lysine acetylation integrates transcriptional programming and metabolism. *Nutrition & Metabolism* **8**, 12.
- Pelet, S., Rudolf, F., Nadal-Ribelles, M., de Nadal, E., Posas, F., and Peter, M. (2011). Transient activation of the HOG MAPK pathway regulates bimodal gene expression. *Science* **332**, 732-735.

- Peters, A.H., O'Carroll, D., Scherthan, H., Mechtler, K., Sauer, S., Schöfer, C., Weipoltshammer, K., Pagani, M., Lachner, M., Kohlmaier, A., *et al.* (2001). Loss of the Suv39h histone methyltransferases impairs mammalian heterochromatin and genome stability. *Cell* **107**, 323-337.
- Phatnani, H.P., and Greenleaf, A.L. (2006). Phosphorylation and functions of the RNA polymerase II CTD. *Genes & Development* **20**, 2922-2936.
- Philip, B., and Levin, D.E. (2001). Wsc1 and Mid2 are cell surface sensors for cell wall integrity signaling that act through Rom2, a guanine nucleotide exchange factor for Rho1. *Molecular and Cellular Biology* **21**, 271-280.
- Philips, J., and Herskowitz, I. (1997). Osmotic balance regulates cell fusion during mating in *Saccharomyces cerevisiae*. *The Journal of Cell Biology* **138**, 961-974.
- Pinskaya, M., Gourvennec, S., and Morillon, A. (2009). H3 lysine 4 di- and tri-methylation deposited by cryptic transcription attenuates promoter activation. *The EMBO Journal* **28**, 1697-1707.
- Pollard, K.J., and Peterson, C.L. (1997). Role for ADA/GCN5 products in antagonizing chromatin-mediated transcriptional repression. *Molecular and Cellular Biology* **17**, 6212-6222.
- Posas, F., Casamayor, A., and Arino, J. (1993). The PPZ protein phosphatases are involved in the maintenance of osmotic stability of yeast cells. *FEBS letters* **318**, 282-286.
- Posas, F., Chambers, J.R., Heyman, J.A., Hoeffler, J.P., de Nadal, E., and Arino, J. (2000). The transcriptional response of yeast to saline stress. *The Journal of Biological Chemistry* **275**, 17249-17255.
- Posas, F., and Saito, H. (1997). Osmotic activation of the HOG MAPK pathway via Ste11p MAPKKK: scaffold role of Pbs2p MAPKK. *Science* **276**, 1702-1705.
- Posas, F., Takekawa, M., and Saito, H. (1998). Signal transduction by MAP kinase cascades in budding yeast. *Current opinion in Microbiology* **1**, 175-182.
- Posas, F., Wurgler-Murphy, S.M., Maeda, T., Witten, E.A., Thai, T.C., and Saito, H. (1996). Yeast HOG1 MAP kinase cascade is regulated by a multistep phosphorelay mechanism in the SLN1-YPD1-SSK1 "two-component" osmosensor. *Cell* **86**, 865-875.
- Pretorius, I.S. (2000). Tailoring wine yeast for the new millennium: novel approaches to the ancient art of winemaking. *Yeast* **16**, 675-729.
- Proft, M., Pascual-Ahuir, A., de Nadal, E., Arino, J., Serrano, R., and Posas, F. (2001). Regulation of the Sko1 transcriptional repressor by the Hog1 MAP kinase in response to osmotic stress. *The EMBO Journal* **20**, 1123-1133.
- Proft, M., and Serrano, R. (1999). Repressors and upstream repressing sequences of the stress-regulated ENA1 gene in *Saccharomyces cerevisiae*: bZIP protein Sko1p confers HOG-dependent osmotic regulation. *Molecular and Cellular Biology* **19**, 537-546.
- Proft, M., and Struhl, K. (2002). Hog1 kinase converts the Sko1-Cyc8-Tup1 repressor complex into an activator that recruits SAGA and SWI/SNF in response to osmotic stress. *Molecular Cell* **9**, 1307-1317.
- Ptashne, M., and Gann, A. (2001). Transcription initiation: imposing specificity by localization. *Essays in biochemistry* **37**, 1-15.

Puig, S., Lau, M., and Thiele, D.J. (2004). Cti6 is an Rpd3-Sin3 histone deacetylase-associated protein required for growth under iron-limiting conditions in *Saccharomyces cerevisiae*. *The Journal of Biological Chemistry* **279**, 30298-30306.

## Q

Quan, T.K., and Hartzog, G.A. (2010). Histone H3K4 and K36 methylation, Chd1 and Rpd3S oppose the functions of *Saccharomyces cerevisiae* Spt4-Spt5 in transcription. *Genetics* **184**, 321-334.

## R

Ragni, E., Piberger, H., Neupert, C., Garcia-Cantalejo, J., Popolo, L., Arroyo, J., Aebi, M., and Strahl, S. (2011). The genetic interaction network of CCW12, a *Saccharomyces cerevisiae* gene required for cell wall integrity during budding and formation of mating projections. *BMC Genomics* **12**, 107.

Raitt, D.C., Johnson, A.L., Erkin, A.M., Makino, K., Morgan, B., Gross, D.S., and Johnston, L.H. (2000). The Skn7 response regulator of *Saccharomyces cerevisiae* interacts with Hsf1 in vivo and is required for the induction of heat shock genes by oxidative stress. *Molecular Biology of the Cell* **11**, 2335-2347.

Randez-Gil, F., Sanz, P., and Prieto, J.A. (1999). Engineering baker's yeast: room for improvement. *Trends in biotechnology* **17**, 237-244.

Redon, C., Pilch, D., Rogakou, E., Sedelnikova, O., Newrock, K., and Bonner, W. (2002). Histone H2A variants H2AX and H2AZ. *Current opinion in Genetics & Development* **12**, 162-169.

Reimold, A.M., Iwakoshi, N.N., Manis, J., Vallabhajosyula, P., Szomolanyi-Tsuda, E., Gravalles, E.M., Friend, D., Grusby, M.J., Alt, F., and Glimcher, L.H. (2001). Plasma cell differentiation requires the transcription factor XBP-1. *Nature* **412**, 300-307.

Reinoso-Martín, C., Schuller, C., Schuetzer-Muehlbauer, M., and Kuchler, K. (2003). The yeast protein kinase C cell integrity pathway mediates tolerance to the antifungal drug caspofungin through activation of Slt2p mitogen-activated protein kinase signaling. *Eukaryotic cell* **2**, 1200-1210.

Reiser, V., Raitt, D.C., and Saito, H. (2003). Yeast osmosensor Sln1 and plant cytokinin receptor Cre1 respond to changes in turgor pressure. *The Journal of Cell Biology* **161**, 1035-1040.

Reiser, V., Ruis, H., and Ammerer, G. (1999). Kinase activity-dependent nuclear export opposes stress-induced nuclear accumulation and retention of Hog1 mitogen-activated protein kinase in the budding yeast *Saccharomyces cerevisiae*. *Molecular Biology of the Cell* **10**, 1147-1161.

Reiser, V., Salah, S.M., and Ammerer, G. (2000). Polarized localization of yeast Pbs2 depends on osmotic stress, the membrane protein Sho1 and Cdc42. *Nature Cell Biology* **2**, 620-627.

Rep, M., Albertyn, J., Thevelein, J.M., Prior, B.A., and Hohmann, S. (1999). Different signalling pathways contribute to the control of GPD1 gene expression by osmotic stress in *Saccharomyces cerevisiae*. *Microbiology* **145 ( Pt 3)**, 715-727.

- Rep, M., Krantz, M., Thevelein, J.M., and Hohmann, S. (2000). The transcriptional response of *Saccharomyces cerevisiae* to osmotic shock. Hot1p and Msn2p/Msn4p are required for the induction of subsets of high osmolarity glycerol pathway-dependent genes. *The Journal of Biological Chemistry* **275**, 8290-8300.
- Rep, M., Reiser, V., Gartner, U., Thevelein, J.M., Hohmann, S., Ammerer, G., and Ruis, H. (1999). Osmotic stress-induced gene expression in *Saccharomyces cerevisiae* requires Msn1p and the novel nuclear factor Hot1p. *Molecular and Cellular Biology* **19**, 5474-5485.
- Richardson, C.E., Kooistra, T., and Kim, D.H. (2010). An essential role for XBP-1 in host protection against immune activation in *C. elegans*. *Nature* **463**, 1092-1095.
- Robert, T., Vanoli, F., Chiolo, I., Shubassi, G., Bernstein, K.A., Rothstein, R., Botrugno, O.A., Parazzoli, D., Oldani, A., Minucci, S., *et al.* (2011). HDACs link the DNA damage response, processing of double-strand breaks and autophagy. *Nature* **471**, 74-79.
- Roeder, R.G., and Rutter, W.J. (1969). Multiple forms of DNA-dependent RNA polymerase in eukaryotic organisms. *Nature* **224**, 234-237.
- Rohde, J., Heitman, J., and Cardenas, M.E. (2001). The TOR kinases link nutrient sensing to cell growth. *The Journal of Biological Chemistry* **276**, 9583-9586.
- Ron, D., and Walter, P. (2007). Signal integration in the endoplasmic reticulum unfolded protein response. *Nature reviews Molecular Cell Biology* **8**, 519-529.
- Roth, S.Y., Denu, J.M., and Allis, C.D. (2001). Histone acetyltransferases. *Annual Review of Biochemistry* **70**, 81-120.
- Rubio, C., Pincus, D., Korennykh, A., Schuck, S., El-Samad, H., and Walter, P. (2011). Homeostatic adaptation to endoplasmic reticulum stress depends on Ire1 kinase activity. *The Journal of Cell Biology* **193**, 171-184.
- Rüeggsegger, U., Leber, J.H., and Walter, P. (2001). Block of *HAC1* mRNA translation by long-range base pairing is released by cytoplasmic splicing upon induction of the unfolded protein response. *Cell* **107**, 103-114.
- Ruis, H., and Schüller, C. (1995). Stress signaling in yeast. *BioEssays : news and reviews in molecular, cellular and developmental biology* **17**, 959-965.
- Ruiz-Roig, C., Vieitez, C., Posas, F., and de Nadal, E. (2010). The Rpd3L HDAC complex is essential for the heat stress response in yeast. *Molecular Microbiology* **76**, 1049-1062.
- Rundlett, S.E., Carmen, A.A., Kobayashi, R., Bavykin, S., Turner, B.M., and Grunstein, M. (1996). HDA1 and RPD3 are members of distinct yeast histone deacetylase complexes that regulate silencing and transcription. *Proceedings of the National Academy of Sciences of the United States of America* **93**, 14503-14508.

## S

- Saha, R.N., and Pahan, K. (2006). HATs and HDACs in neurodegeneration: a tale of disconcerted acetylation homeostasis. *Cell death and Differentiation* **13**, 539-550.

- Saito, H. (2010). Regulation of cross-talk in yeast MAPK signaling pathways. *Current opinion in Microbiology* **13**, 677-683.
- Savoie, S., Rindress, D., Posner, B.I., and Bergeron, J.J. (1986). Tunicamycin sensitivity of prolactin, insulin and epidermal growth factor receptors in rat liver plasmalemma. *Molecular and Cellular Endocrinology* **45**, 241-246.
- Schindler, U., Beckmann, H., and Cashmore, A.R. (1993). HAT3.1, a novel Arabidopsis homeodomain protein containing a conserved cysteine-rich region. *The Plant journal : for Cell and Molecular Biology* **4**, 137-150.
- Schmelzle, T., and Hall, M.N. (2000). TOR, a central controller of cell growth. *Cell* **103**, 253-262.
- Schmidt, A., Bickle, M., Beck, T., and Hall, M.N. (1997). The yeast phosphatidylinositol kinase homolog TOR2 activates RHO1 and RHO2 via the exchange factor ROM2. *Cell* **88**, 531-542.
- Schmidt, A., Kunz, J., and Hall, M.N. (1996). TOR2 is required for organization of the actin cytoskeleton in yeast. *Proceedings of the National Academy of Sciences of the United States of America* **93**, 13780-13785.
- Schmitt, A.P., and McEntee, K. (1996). Msn2p, a zinc finger DNA-binding protein, is the transcriptional activator of the multistress response in *Saccharomyces cerevisiae*. *Proceedings of the National Academy of Sciences of the United States of America* **93**, 5777-5782.
- Schröder, M., Chang, J.S., and Kaufman, R.J. (2000). The unfolded protein response represses nitrogen-starvation induced developmental differentiation in yeast. *Genes & Development* **14**, 2962-2975.
- Schröder, M., Clark, R., and Kaufman, R.J. (2003). *IRE1*- and *HAC1*-independent transcriptional regulation in the unfolded protein response of yeast. *Molecular Microbiology* **49**, 591-606.
- Schröder, M., Clark, R., Liu, C.Y., and Kaufman, R.J. (2004). The unfolded protein response represses differentiation through the *RPD3-SIN3* histone deacetylase. *The EMBO Journal* **23**, 2281-2292.
- Schröder, M., and Kaufman, R.J. (2005). The mammalian unfolded protein response. *Annual Review of Biochemistry* **74**, 739-789.
- Schüller, C., Brewster, J.L., Alexander, M.R., Gustin, M.C., and Ruis, H. (1994). The HOG pathway controls osmotic regulation of transcription via the stress response element (STRE) of the *Saccharomyces cerevisiae* CTT1 gene. *The EMBO Journal* **13**, 4382-4389.
- Scrimale, T., Didone, L., de Mesy Bentley, K.L., and Krysan, D.J. (2009). The unfolded protein response is induced by the cell wall integrity mitogen-activated protein kinase signaling cascade and is required for cell wall integrity in *Saccharomyces cerevisiae*. *Molecular Biology of the Cell* **20**, 164-175.
- Segall, J., Matsui, T., and Roeder, R.G. (1980). Multiple factors are required for the accurate transcription of purified genes by RNA polymerase III. *The Journal of Biological Chemistry* **255**, 11986-11991.
- Seligson, D.B., Horvath, S., McBrien, M.A., Mah, V., Yu, H., Tze, S., Wang, Q., Chia, D., Goodglick, L., and Kurdستاني, S.K. (2009). Global levels of histone modifications predict prognosis in different cancers. *The American Journal of Pathology* **174**, 1619-1628.
- Sendra, R., Tse, C., and Hansen, J.C. (2000). The yeast histone acetyltransferase A2 complex, but not free Gcn5p, binds stably to nucleosomal arrays. *The Journal of Biological Chemistry* **275**, 24928-24934.



- Seong, K.H., Li, D., Shimizu, H., Nakamura, R., and Ishii, S. (2011). Inheritance of stress-induced, ATF-2-dependent epigenetic change. *Cell* **145**, 1049-1061.
- Serrano, R. (1996). Salt tolerance in plants and microorganisms: toxicity targets and defense responses. *International review of Cytology* **165**, 1-52.
- Serrano, R., Márquez, J. A. and Ri'os, G. (1997). Crucial factors in salt tolerance., 147–169. In Hohmann, S. and Mager, W. H. (ed.), *Yeast stress responses*. Landes, R. G., Austin, Tex.
- Sertil, O., Vemula, A., Salmon, S.L., Morse, R.H., and Lowry, C.V. (2007). Direct role for the Rpd3 complex in transcriptional induction of the anaerobic *DAN/TIR* genes in yeast. *Molecular and Cellular Biology* **27**, 2037-2047.
- Shaffer, A.L., Shapiro-Shelef, M., Iwakoshi, N.N., Lee, A.H., Qian, S.B., Zhao, H., Yu, X., Yang, L., Tan, B.K., Rosenwald, A., *et al.* (2004). XBP1, downstream of Blimp-1, expands the secretory apparatus and other organelles, and increases protein synthesis in plasma cell differentiation. *Immunity* **21**, 81-93.
- Shankar, S., and Srivastava, R.K. (2008). Histone deacetylase inhibitors: mechanisms and clinical significance in cancer: HDAC inhibitor-induced apoptosis. *Advances in experimental medicine and biology* **615**, 261-298.
- Sharma, V.M., Tomar, R.S., Dempsey, A.E., and Reese, J.C. (2007). Histone deacetylases RPD3 and HOS2 regulate the transcriptional activation of DNA damage-inducible genes. *Molecular and Cellular Biology* **27**, 3199-3210.
- Sherman, F., and Hicks, J. (1991). Micromanipulation and dissection of asci. *Methods in Enzymology* **194**, 21-37.
- Shivaswamy, S., and Iyer, V.R. (2008). Stress-dependent dynamics of global chromatin remodeling in yeast: dual role for SWI/SNF in the heat shock stress response. *Molecular and Cellular Biology* **28**, 2221-2234.
- Siderius, M., and Mager, W.H. (1997). The general stress response in search for a common denominator, 213–230. In Hohmann, S. and Mager, W.H. (ed.), *Yeast stress responses*. Landes, R.G., Company, Austin, Tex.
- Sidrauski, C., Cox, J.S., and Walter, P. (1996). tRNA ligase is required for regulated mRNA splicing in the unfolded protein response. *Cell* **87**, 405-413.
- Sikorski, R.S., and Hieter, P. (1989). A system of shuttle vectors and yeast host strains designed for efficient manipulation of DNA in *Saccharomyces cerevisiae*. *Genetics* **122**, 19-27.
- Simons, J.F., Ebersold, M., and Helenius, A. (1998). Cell wall 1,6-beta-glucan synthesis in *Saccharomyces cerevisiae* depends on ER glucosidases I and II, and the molecular chaperone BiP/Kar2p. *The EMBO journal* **17**, 396-405.
- Smith, A., Ward, M.P., and Garrett, S. (1998). Yeast PKA represses Msn2p/Msn4p-dependent gene expression to regulate growth, stress response and glycogen accumulation. *The EMBO Journal* **17**, 3556-3564.
- Spange, S., Wagner, T., Heinzl, T., and Krämer, O.H. (2009). Acetylation of non-histone proteins modulates cellular signalling at multiple levels. *The International Journal of Biochemistry & Cell Biology* **41**, 185-198.

- Sriburi, R., Jackowski, S., Mori, K., and Brewer, J.W. (2004). XBP1: a link between the unfolded protein response, lipid biosynthesis, and biogenesis of the endoplasmic reticulum. *The Journal of Cell Biology* **167**, 35-41.
- Sterner, D.E., and Berger, S.L. (2000). Acetylation of histones and transcription-related factors. *Microbiology and Molecular Biology Reviews* : MMBR **64**, 435-459.
- Stillman, D.J., Dorland, S., and Yu, Y. (1994). Epistasis analysis of suppressor mutations that allow HO expression in the absence of the yeast SW15 transcriptional activator. *Genetics* **136**, 781-788.
- Strahl, B.D., and Allis, C.D. (2000). The language of covalent histone modifications. *Nature* **403**, 41-45.
- Strich, R., Slater, M.R., and Esposito, R.E. (1989). Identification of negative regulatory genes that govern the expression of early meiotic genes in yeast. *Proceedings of the National Academy of Sciences of the United States of America* **86**, 10018-10022.
- Strich, R., Surosky, R.T., Steber, C., Dubois, E., Messenguy, F., and Esposito, R.E. (1994). UME6 is a key regulator of nitrogen repression and meiotic development. *Genes & Development* **8**, 796-810.
- Struhl, K. (1998). Histone acetylation and transcriptional regulatory mechanisms. *Genes & Development* **12**, 599-606.
- Sun, X., Li, Y., Cai, H., Bai, X., Ji, W., Ding, X., and Zhu, Y. (2011). The Arabidopsis AtbZIP1 transcription factor is a positive regulator of plant tolerance to salt, osmotic and drought stresses. *Journal of Plant Research*.
- Sussel, L., Vannier, D., and Shore, D. (1993). Epigenetic switching of transcriptional states: cis- and trans-acting factors affecting establishment of silencing at the HMR locus in *Saccharomyces cerevisiae*. *Molecular and Cellular Biology* **13**, 3919-3928.
- Svotelis, A., Gévry, N., and Gaudreau, L. (2009). Regulation of gene expression and cellular proliferation by histone H2A.Z. *Biochemistry and Cell Biology = Biochimie et biologie cellulaire* **87**, 179-188.
- Syntichaki, P., Topalidou, I., and Thireos, G. (2000). The Gcn5 bromodomain co-ordinates nucleosome remodelling. *Nature* **404**, 414-417.
- Szopinska, A., Degand, H., Hochstenbach, J.F., Nader, J., and Morsomme, P. (2011). Rapid response of the yeast plasma membrane proteome to salt stress. *Molecular & Cellular Proteomics* : MCP **10**, M111009589.

## T

- Tamas, M.J., Luyten, K., Sutherland, F.C., Hernandez, A., Albertyn, J., Valadi, H., Li, H., Prior, B.A., Kilian, S.G., Ramos, J., *et al.* (1999). Fps1p controls the accumulation and release of the compatible solute glycerol in yeast osmoregulation. *Molecular Microbiology* **31**, 1087-1104.
- Tamkun, J.W., Deuring, R., Scott, M.P., Kissinger, M., Pattatucci, A.M., Kaufman, T.C., and Kennison, J.A. (1992). brahma: a regulator of Drosophila homeotic genes structurally related to the yeast transcriptional activator SNF2/SWI2. *Cell* **68**, 561-572.
- Tan, F., Zhang, K., Mujahid, H., Verma, D.P., and Peng, Z. (2011). Differential histone modification and protein expression associated with cell wall removal and regeneration in rice (*Oryza sativa*). *Journal of Proteome Research* **10**, 551-563.

- Tan, S.X., Teo, M., Lam, Y.T., Dawes, I.W., and Perrone, G.G. (2009). Cu, Zn superoxide dismutase and NADP(H) homeostasis are required for tolerance of endoplasmic reticulum stress in *Saccharomyces cerevisiae*. *Molecular Biology of the Cell* **20**, 1493-1508.
- Taunton, J., Hassig, C.A., and Schreiber, S.L. (1996). A mammalian histone deacetylase related to the yeast transcriptional regulator Rpd3p. *Science* **272**, 408-411.
- Thevelein, J.M., and de Winde, J.H. (1999). Novel sensing mechanisms and targets for the cAMP-protein kinase A pathway in the yeast *Saccharomyces cerevisiae*. *Molecular Microbiology* **33**, 904-918.
- Tokoro, M., Shin, S.W., Nishikawa, S., Lee, H.H., Hatanaka, Y., Amano, T., Mitani, T., Kato, H., Anzai, M., Kishigami, S., *et al.* (2010). Deposition of acetylated histones by RNAP II promoter clearance may occur at onset of zygotic gene activation in preimplantation mouse embryos. *The Journal of Reproduction and Development* **56**, 607-615.
- Tong, A.H., Evangelista, M., Parsons, A.B., Xu, H., Bader, G.D., Page, N., Robinson, M., Raghibizadeh, S., Hogue, C.W., Bussey, H., *et al.* (2001). Systematic genetic analysis with ordered arrays of yeast deletion mutants. *Science* **294**, 2364-2368.
- Tong, A.H., Lesage, G., Bader, G.D., Ding, H., Xu, H., Xin, X., Young, J., Berriz, G.F., Brost, R.L., Chang, M., *et al.* (2004). Global mapping of the yeast genetic interaction network. *Science* **303**, 808-813.
- Torres, J., Di Como, C.J., Herrero, E., and De La Torre-Ruiz, M.A. (2002). Regulation of the cell integrity pathway by rapamycin-sensitive TOR function in budding yeast. *The Journal of Biological Chemistry* **277**, 43495-43504.
- Torres-Quiroz, F., García-Marqués, S., Coria, R., Randez-Gil, F., and Prieto, J.A. (2010). The activity of yeast Hog1 MAPK is required during endoplasmic reticulum stress induced by tunicamycin exposure. *The Journal of Biological Chemistry* **285**, 20088-20096.
- Travers, K.J., Patil, C.K., Wodicka, L., Lockhart, D.J., Weissman, J.S., and Walter, P. (2000). Functional and genomic analyses reveal an essential coordination between the unfolded protein response and ER-associated degradation. *Cell* **101**, 249-258.
- Travis, G.H., Colavito-Shepanski, M., and Grunstein, M. (1984). Extensive purification and characterization of chromatin-bound histone acetyltransferase from *Saccharomyces cerevisiae*. *The Journal of Biological Chemistry* **259**, 14406-14412.
- Treger, J.M., Magee, T.R., and McEntee, K. (1998). Functional analysis of the stress response element and its role in the multistress response of *Saccharomyces cerevisiae*. *Biochemical and Biophysical Research Communications* **243**, 13-19.
- Triebel, R.C., Rojas, J.R., Sterner, D.E., Venkataramani, R.N., Wang, L., Zhou, J., Allis, C.D., Berger, S.L., and Marmorstein, R. (1999). Crystal structure and mechanism of histone acetylation of the yeast GCN5 transcriptional coactivator. *Proceedings of the National Academy of Sciences of the United States of America* **96**, 8931-8936.
- Tse, C., Sera, T., Wolffe, A.P., and Hansen, J.C. (1998). Disruption of higher-order folding by core histone acetylation dramatically enhances transcription of nucleosomal arrays by RNA polymerase III. *Molecular and Cellular Biology* **18**, 4629-4638.
- Turner, B.M. (1993). Decoding the nucleosome. *Cell* **75**, 5-8.

Turner, B.M., Birley, A.J., and Lavender, J. (1992). Histone H4 isoforms acetylated at specific lysine residues define individual chromosomes and chromatin domains in *Drosophila* polytene nuclei. *Cell* **69**, 375-384.

Tyson, J.R., and Stirling, C.J. (2000). LHS1 and SIL1 provide a luminal function that is essential for protein translocation into the endoplasmic reticulum. *The EMBO Journal* **19**, 6440-6452.

## U

Urade, R. (2009). The endoplasmic reticulum stress signaling pathways in plants. *BioFactors* **35**, 326-331.

Urano, F., Wang, X., Bertolotti, A., Zhang, Y., Chung, P., Harding, H.P., and Ron, D. (2000). Coupling of stress in the ER to activation of JNK protein kinases by transmembrane protein kinase IRE1. *Science* **287**, 664-666.

## V

Vannini, A., Volpari, C., Gallinari, P., Jones, P., Mattu, M., Carfi, A., De Francesco, R., Steinkuhler, C., and Di Marco, S. (2007). Substrate binding to histone deacetylases as shown by the crystal structure of the HDAC8-substrate complex. *EMBO Reports* **8**, 879-884.

Värv, S., Kristjuhan, K., Peil, K., Lõoke, M., Mahlakõiv, T., Paapsi, K., and Kristjuhan, A. (2010). Acetylation of H3 K56 is required for RNA polymerase II transcript elongation through heterochromatin in yeast. *Molecular and Cellular Biology* **30**, 1467-1477.

Vempati, R.K. (2012). DNA damage in the presence of chemical genotoxic agents induce acetylation of H3K56 and H4K16 but not H3K9 in mammalian cells. *Molecular biology reports* **39**, 303-308.

Vermeulen, M., Eberl, H.C., Matarese, F., Marks, H., Denissov, S., Butter, F., Lee, K.K., Olsen, J.V., Hyman, A.A., Stunnenberg, H.G., *et al.* (2010). Quantitative interaction proteomics and genome-wide profiling of epigenetic histone marks and their readers. *Cell* **142**, 967-980.

Verna, J., Lodder, A., Lee, K., Vagts, A., and Ballester, R. (1997). A family of genes required for maintenance of cell wall integrity and for the stress response in *Saccharomyces cerevisiae*. *Proceedings of the National Academy of Sciences of the United States of America* **94**, 13804-13809.

Vidal, M., Buckley, A.M., Hilger, F., and Gaber, R.F. (1990). Direct selection for mutants with increased K<sup>+</sup> transport in *Saccharomyces cerevisiae*. *Genetics* **125**, 313-320.

Vidal, M., Strich, R., Esposito, R.E., and Gaber, R.F. (1991). RPD1 (SIN3/UME4) is required for maximal activation and repression of diverse yeast genes. *Molecular and Cellular Biology* **11**, 6306-6316.

Vidali, G., Gershay, E.L., and Allfrey, V.G. (1968). Chemical studies of histone acetylation. The distribution of epsilon-N-acetyllysine in calf thymus histones. *The Journal of Biological Chemistry* **243**, 6361-6366.

Vlaicu, S.I., Tegla, C.A., Cudrici, C.D., Fosbrink, M., Nguyen, V., Azimzadeh, P., Rus, V., Chen, H., Mircea, P.A., Shamsuddin, A., *et al.* (2010). Epigenetic modifications induced by RGC-32 in colon cancer. *Experimental and molecular pathology* **88**, 67-76.

**W**

- Wach, A. (1996). PCR-synthesis of marker cassettes with long flanking homology regions for gene disruptions in *S. cerevisiae*. *Yeast* **12**, 259-265.
- Wach, A., Brachat, A., Pöhlmann, R., and Philippsen, P. (1994). New heterologous modules for classical or PCR-based gene disruptions in *Saccharomyces cerevisiae*. *Yeast* **10**, 1793-1808.
- Wallis, J.W., Rykowski, M., and Grunstein, M. (1983). Yeast histone H2B containing large amino terminus deletions can function in vivo. *Cell* **35**, 711-719.
- Wang, S.S., Zhou, B.O., and Zhou, J.Q. (2011). Histone H3 lysine 4 hypermethylation prevents aberrant nucleosome remodeling at the PHO5 promoter. *Molecular and Cellular Biology* **31**, 3171-3181.
- Watanabe, Y., Irie, K., and Matsumoto, K. (1995). Yeast RLM1 encodes a serum response factor-like protein that may function downstream of the Mpk1 (Slt2) mitogen-activated protein kinase pathway. *Molecular and Cellular Biology* **15**, 5740-5749.
- Welihinda, A.A., Tirasophon, W., Green, S.R., and Kaufman, R.J. (1997). Gene induction in response to unfolded protein in the endoplasmic reticulum is mediated through Ire1p kinase interaction with a transcriptional coactivator complex containing Ada5p. *Proceedings of the National Academy of Sciences of the United States of America* **94**, 4289-4294.
- Welihinda, A.A., Tirasophon, W., and Kaufman, R.J. (2000). The transcriptional co-activator ADA5 is required for HAC1 mRNA processing in vivo. *The Journal of Biological Chemistry* **275**, 3377-3381.
- Witt, O., Albig, W., and Doenecke, D. (1996). Testis-specific expression of a novel human H3 histone gene. *Experimental Cell Research* **229**, 301-306.
- Wu, J., Carmen, A.A., Kobayashi, R., Suka, N., and Grunstein, M. (2001). HDA2 and HDA3 are related proteins that interact with and are essential for the activity of the yeast histone deacetylase HDA1. *Proceedings of the National Academy of Sciences of the United States of America* **98**, 4391-4396.

**X**

- Xhemalce, B., and Kouzarides, T. (2010). A chromodomain switch mediated by histone H3 Lys 4 acetylation regulates heterochromatin assembly. *Genes & Development* **24**, 647-652.
- Xin, X., Lan, C., Lee, H.C., and Zhang, L. (2007). Regulation of the *HAP1* gene involves positive actions of histone deacetylases. *Biochemical and Biophysical Research Communications* **362**, 120-125.
- Xue, K., Song, J., Wei, H., Chen, L., Ma, Y., Liu, S., Li, Y., Dai, Y., Zhao, Y., and Li, N. (2010). Synchronous behaviors of CBP and acetylations of lysine 18 and lysine 23 on histone H3 during porcine oocyte first meiotic division. *Molecular Reproduction and Development* **77**, 605-614.

**Y**

- Yale, J., and Bohnert, H.J. (2001). Transcript expression in *Saccharomyces cerevisiae* at high salinity. *The Journal of Biological Chemistry* **276**, 15996-16007.

- Yancey, P.H. (2004). Compatible and counteracting solutes: protecting cells from the Dead Sea to the deep sea. *Science Progress* **87**, 1-24.
- Yancey, P.H. (2005). Organic osmolytes as compatible, metabolic and counteracting cytoprotectants in high osmolarity and other stresses. *The Journal of Experimental Biology* **208**, 2819-2830.
- Yang, X.J., and Gregoire, S. (2005). Class II histone deacetylases: from sequence to function, regulation, and clinical implication. *Molecular and Cellular Biology* **25**, 2873-2884.
- Yang, X.J., and Seto, E. (2008). Lysine acetylation: codified crosstalk with other posttranslational modifications. *Molecular Cell* **31**, 449-461.
- Ying, S., Zhang, D.F., Fu, J., Shi, Y.S., Song, Y.C., Wang, T.Y., and Li, Y. (2011). Cloning and characterization of a maize bZIP transcription factor, ZmbZIP72, confers drought and salt tolerance in transgenic *Arabidopsis*. *Planta*.
- Yoneda, T., Imaizumi, K., Oono, K., Yui, D., Gomi, F., Katayama, T., and Tohyama, M. (2001). Activation of caspase-12, an endoplasmic reticulum (ER) resident caspase, through tumor necrosis factor receptor-associated factor 2-dependent mechanism in response to the ER stress. *The Journal of Biological Chemistry* **276**, 13935-13940.
- Yoshida, H. (2007). ER stress and diseases. *The FEBS Journal* **274**, 630-658.
- Yoshida, H., Haze, K., Yanagi, H., Yura, T., and Mori, K. (1998). Identification of the *cis*-acting endoplasmic reticulum stress response element responsible for transcriptional induction of mammalian glucose-regulated proteins. Involvement of basic leucine zipper transcription factors. *The Journal of Biological Chemistry* **273**, 33741-33749.
- Yoshida, H., Matsui, T., Yamamoto, A., Okada, T., and Mori, K. (2001). XBP1 mRNA is induced by ATF6 and spliced by IRE1 in response to ER stress to produce a highly active transcription factor. *Cell* **107**, 881-891.
- Yoshida, H., Okada, T., Haze, K., Yanagi, H., Yura, T., Negishi, M., and Mori, K. (2000). ATF6 activated by proteolysis binds in the presence of NF-Y (CBF) directly to the *cis*-acting element responsible for the mammalian unfolded protein response. *Molecular and Cellular Biology* **20**, 6755-6767.
- Yoshida, H., Oku, M., Suzuki, M., and Mori, K. (2006). pXBP1(U) encoded in XBP1 pre-mRNA negatively regulates unfolded protein response activator pXBP1(S) in mammalian ER stress response. *The Journal of Cell Biology* **172**, 565-575.
- Yoshida, S., Ohya, Y., Goebel, M., Nakano, A., and Anraku, Y. (1994). A novel gene, STT4, encodes a phosphatidylinositol 4-kinase in the PKC1 protein kinase pathway of *Saccharomyces cerevisiae*. *The Journal of Biological Chemistry* **269**, 1166-1172.
- Yu, J., Angelin-Duclos, C., Greenwood, J., Liao, J., and Calame, K. (2000). Transcriptional repression by blimp-1 (PRDI-BF1) involves recruitment of histone deacetylase. *Molecular and Cellular Biology* **20**, 2592-2603.
- Yukawa, M., Katoh, S., Miyakawa, T., and Tsuchiya, E. (1999). Nps1/Sth1p, a component of an essential chromatin-remodeling complex of *Saccharomyces cerevisiae*, is required for the maximal expression of early meiotic genes. *Genes to cells : devoted to molecular & cellular mechanisms* **4**, 99-110.

- Zarzov, P., Mazzone, C., and Mann, C. (1996). The SLT2(MPK1) MAP kinase is activated during periods of polarized cell growth in yeast. *The EMBO Journal* **15**, 83-91.
- Zeng, L., Zhang, Q., Gerona-Navarro, G., Moshkina, N., and Zhou, M.M. (2008). Structural basis of site-specific histone recognition by the bromodomains of human coactivators PCAF and CBP/p300. *Structure* **16**, 643-652.
- Zeng, L., Zhang, Q., Li, S., Plotnikov, A.N., Walsh, M.J., and Zhou, M.M. (2010). Mechanism and regulation of acetylated histone binding by the tandem PHD finger of DPF3b. *Nature* **466**, 258-262.
- Zhang, K., Wong, H.N., Song, B., Miller, C.N., Scheuner, D., and Kaufman, R.J. (2005). The unfolded protein response sensor IRE1alpha is required at 2 distinct steps in B cell lymphopoiesis. *The Journal of Clinical Investigation* **115**, 268-281.
- Zhang, Y., and Reinberg, D. (2001). Transcription regulation by histone methylation: interplay between different covalent modifications of the core histone tails. *Genes & Development* **15**, 2343-2360.
- Zhou, B.O., Wang, S.S., Zhang, Y., Fu, X.H., Dang, W., Lenzmeier, B.A., and Zhou, J.Q. (2011). Histone H4 lysine 12 acetylation regulates telomeric heterochromatin plasticity in *Saccharomyces cerevisiae*. *PLoS Genetics* **7**, e1001272.

