



Durham E-Theses

Silenes as novel synthetic reagents

Whelligan, Daniel Keith

How to cite:

Whelligan, Daniel Keith (2003) *Silenes as novel synthetic reagents*, Durham theses, Durham University. Available at Durham E-Theses Online: <http://etheses.dur.ac.uk/3135/>

Use policy

The full-text may be used and/or reproduced, and given to third parties in any format or medium, without prior permission or charge, for personal research or study, educational, or not-for-profit purposes provided that:

- a full bibliographic reference is made to the original source
- a [link](#) is made to the metadata record in Durham E-Theses
- the full-text is not changed in any way

The full-text must not be sold in any format or medium without the formal permission of the copyright holders.

Please consult the [full Durham E-Theses policy](#) for further details.

Silenes as Novel Synthetic Reagents



A copyright of this thesis rests with the author. No quotation from it should be published without his prior written consent and information derived from it should be acknowledged.

Daniel Keith Whelligan, M.A., M.Sci.

Ph.D Thesis

University of Durham

Department of Chemistry

December 2003



28 APR 2004

Acknowledgements

For their assistance and friendship during this PhD, I would like to thank:

My supervisor, Dr. Patrick Steel for so much guidance during lab work and the writing of this thesis and for teaching me diverse new chemical knowledge through group meetings. Also for a lot of encouragement and advice in obtaining a postdoc. and finally, for some good climbing tuition!

My CASE supervisor from GSK, Dr. Mahesh Sanganeer for his unerring enthusiasm for the project, fresh ideas (above all using KO^tBu instead of MeLi), his assistance in the lab during my 3 month placement and for the dramatic improvement of my safety skills!

Lab-mate postdocs. Dr. Les Oates and Dr. Simon deSousa for a great amount of help with practical lab work, spectral analysis and general chemistry. Fellow CG1 lab-mates, Alan, Andy, Anne, Catherine, Chris, Darren, Davide, Ed, Ganesh, Ishmael, Jonathan, Jun, Katherine, Kathryn, Laila, Lisa, Neal, Ollie, Steve, Wendy, Ximo and particularly my close friends Amel, Chris and Pete, for help with chemistry, the fantastic group spirit, social-life and for all the laughs. My very good friends from outside the lab, Matt, Rhona and especially Lyndsy, for so many great times over the last three years and for all the help and support.

Dr. Elizabeth Grayson for her professional and diligent proof-reading of this thesis and also for her advice and encouragement in obtaining a postdoc.

Dr. Alan Kenwright, Ian McKeag and Katherine Heffernan for all the NMR work, especially for whole days of complicated Silicon-29 experiments and aesthetic manipulations of the data for its presentation in this thesis. Dr. Mike Jones and Lara Turner for all mass spectrometry, including about a million GCMS's. Ritu Katakya, Lenny Lauchlan and Jaroslava Dostal for GC's and elemental analysis. All of the remaining technical staff in the department, in particular glassblowers Malcolm and Peter for one or two repairs(!).

EPSRC and GSK for generous funding.

Last, but certainly not least, my mum, dad and sisters, Kate, Lisa and Hollie, who are always there for me.

Contents

Acknowledgements.....	I
Contents	II
Abbreviations.....	IV
Abstract.....	VII
Declaration.....	VIII
Copyright.....	VIII
1 Introduction.....	1
1.1 General Introduction.....	1
1.2 Selected Aspects of Organosilicon Chemistry.....	1
1.2.1.1 Introduction.....	1
1.2.1.2 Bond Lengths.....	2
1.2.1.3 Bond Strengths.....	2
1.2.1.4 Inductive Effects.....	4
1.2.1.5 Nucleophilic Substitution at Silicon.....	4
1.2.1.6 Stabilisation of α -Carbanions and β -Carbocations.....	4
1.3 History of Silenes.....	5
1.3.1 Initial Discoveries.....	5
1.3.2 Stable Silenes.....	8
1.4 Generation of Silenes.....	11
1.4.1 Introduction.....	11
1.4.2 Gas-phase Pyrolysis Reactions.....	11
1.4.3 Solution-phase Thermolysis Reactions.....	13
1.4.4 Photolysis Reactions.....	13
1.4.5 Salt Elimination Reactions.....	15
1.4.6 Modified Peterson Olefination.....	17
1.4.6.1 Introduction.....	17
1.4.6.2 Peterson Olefination.....	17
1.4.6.3 Modified Peterson Olefination.....	18
1.5 Reactions of Silenes.....	24
1.5.1 Introduction.....	24
1.5.2 Dimerisation.....	24
1.5.2.1 Introduction.....	24
1.5.2.2 Head to Tail Dimerisation.....	25
1.5.2.3 Head to Head Dimerisation.....	25
1.5.2.4 'Ene' Type Dimerisation.....	27
1.5.3 Cycloadditions and Ene Reactions with Alkenes and Dienes.....	28
1.5.3.1 Introduction.....	28
1.5.3.2 Chemoselectivity ([4+2], [2+2] or Ene).....	28
1.5.3.3 Regioselectivity.....	33
1.5.3.4 Stereoselectivity.....	35
1.5.3.5 Summary.....	38
1.5.4 Cycloadditions and Ene Reactions with Carbonyl Compounds and Imines.....	38
1.5.5 Reactions with Nucleophiles.....	40
1.6 Project Strategy.....	41
2 Aryltris(trimethylsilyl)silanes.....	45
2.1 Introduction.....	45
2.2 Investigation of the Brook Synthesis.....	46
2.3 One-Step Syntheses.....	47
2.3.1 Reactive Metal Coupling Reactions.....	47

2.3.2	Application of TMSLi.....	50
2.3.3	Conclusion	51
2.4	Modification of the Brook Synthesis.....	51
2.4.1	Reaction of Silyllithium 80 with Bromine.....	51
2.4.2	Alternative Brominating Agents	54
2.4.2.1	Tetrabutylammonium tribromide (^t Bu ₄ NBr ₃).....	54
2.4.2.2	N-Bromosuccinimide (NBS)	55
2.5	Palladium Coupling Reactions.....	58
3	Silene Precursors.....	63
3.1	Introduction.....	63
3.2	Use of the Oehme/Griffiths Synthesis	64
3.3	Adaptation of the Oehme/Griffiths Synthesis.....	66
3.4	Alternative Synthesis <i>via</i> Acylpolysilanes.....	73
3.5	Conclusion	74
4	Silene Generation.....	75
4.1	Introduction.....	75
4.2	Alternative Bases and Mechanistic Studies	76
4.2.1	Use of MeLi	76
4.2.2	Use of Alternative Bases.....	77
4.2.3	Use of Lithium Salt Additives	79
4.2.4	Use of <i>p</i> -Methoxyphenyl Substituted Silyl Alcohol.....	81
4.3	Conclusion	82
5	Silacycles	83
5.1	Introduction.....	83
5.1.1	Silacycle Synthesis and Elaboration	83
5.1.2	Oxidation of Organosilicon Compounds	83
5.2	Silacycles Derived from Various Dienes.....	85
5.2.1	1,3-Pentadiene.....	85
5.2.2	2,3-Dimethylbutadiene.....	88
5.2.2.1	Silacycle Formation and Stereochemistry	88
5.2.2.2	Silacycle Elaboration	91
5.2.3	Isoprene.....	94
5.2.4	2-Methyl-1,3-pentadiene.....	96
5.2.5	3-Methyl-1,3-pentadiene.....	98
5.2.6	Anomalous Diene Trapping Experiments.....	100
5.2.6.1	1-Methoxy-1,3-butadiene.....	100
5.2.6.2	Cyclohexadiene.....	100
5.2.6.3	1,6-Dimethoxy- <i>trans-trans</i> -2,4-hexadiene	101
5.2.7	Summary and Conclusion	102
5.3	Silacycles Derived from Various Silyl Alcohols	103
5.3.1	Hydrogenation Followed by Oxidation	103
5.3.1.1	Stereochemistry of the ^t Bu-Substituted Silacycle 363.....	105
5.3.1.2	Fleming-Tamao Oxidation and the Phenyl-Substituted Silacycle.....	106
5.3.2	Direct Oxidation of Unsaturated Silacycles.....	107
5.4	Alternative Silacycle Elaborations.....	108
5.5	Conclusions.....	109
6	Conclusions and Future Work	110
7	Experimental Procedures	112
7.1	General Procedures	112
7.2	Experimental Detail	114
	Appendix.....	182
	References.....	183

Abbreviations

The following abbreviations are used in this report:

Approx.	Approximately
3ax	axial proton on carbon 3
biph	biphenyl
b.p.	Boiling point
Bz	Benzoyl
c-Hx	cyclohexyl
CI	Chemical ionisation
cod	cyclooctadiene
Conc.	Concentrated
COSY	Correlation spectroscopy
d	Doublet
dba	dibenzylideneacetone
DCM	Dichloromethane
DEPT	Distortionless enhanced polarisation transfer
DMAP	<i>N,N</i> -dimethylaminopyridine
DME	Dimethoxyethane
DMPU	<i>N,N'</i> -dimethyl- <i>N,N'</i> -propylene urea
dppf	1,1'-bis(diphenylphosphino)ferrocene
e.e.	enantiomeric excess
EI	Electron ionisation
EPSRC	Engineering and physical sciences research council
3eq	equatorial proton on carbon 3
eq.	Equivalents
ESR	Electron spin resonance
Et	Ethyl
ether	diethyl ether
GC	Gas chromatography
GCMS	Gas chromatography – mass spectroscopy
h	Hours
H ^E	Proton in the <i>trans</i> position to the alkyl group
hex	Hexet

HMPA	Hexamethylphosphoramide
HMQC	Heteronuclear multiple quantum correlation
HOMO	Highest occupied molecular orbital
HRMS	High resolution mass spectroscopy
HSQC	Heteronuclear single quantum correlation
H ^Z	Proton in the <i>cis</i> position to the alkyl group
IR	Infra red
kJ	Kilojoule
LCMS	Liquid chromatography mass spectrometry
lit.	Literature data
LHMDS	Lithium bis(trimethylsilyl)amide
LUMO	Lowest unoccupied molecular orbital
M	Molar
m	Multiplet
<i>m</i> CPBA	<i>meta</i> -Chloroperbenzoic acid
Me	Methyl
MeLi	Methyl lithium
Mes	Mesityl
min	Minutes
mmHg	Millimetres of mercury
mmol	Millimole
mol	Mole
m.p.	Melting point
MS	Mass spectroscopy
ⁿ Bu	Primary butyl
NBS	<i>N</i> -bromosuccinimide
NCS	<i>N</i> -chlorosuccinimide
NIS	<i>N</i> -iodosuccinimide
NMO	<i>N</i> -methylmorpholine- <i>N</i> -oxide
NMR	Nuclear magnetic resonance
<i>n</i> Oe	Nuclear overhauser effect
NOESY	Nuclear overhauser effect spectroscopy
o/n	Overnight
pent	Pentet
pet. ether	Petroleum ether
Ph	Phenyl

ppm	Parts per million
pyr	Pyridine
q	Quartet
R	Alkyl
Red-Al	Sodium bis(2-methoxyethoxy)aluminium hydride
R _f	Retention factor
RT	Room temperature
s	Singlet
^s Bu	Secondary butyl
SM	Starting material
t	Triplet
^t Bu	Tertiary butyl
Tf	Triflate (Trifluorosulfonate, -SO ₂ CF ₃)
THF	Tetrahydrofuran
TLC	Thin layer chromatography
TMEDA	Tetramethylethyldiamine
TMS	Trimethylsilyl
Tol	Tolyl
TPAP	Tetrapropylammonium perruthenate
Ts	Tosylate (<i>p</i> -tolylsulfonyl)
UV	Ultraviolet

Abstract

Silenes as Novel Synthetic Reagents

Daniel Keith Whelligan

Ph.D, December 2003

Several syntheses of aryltris(trimethylsilyl)silanes were investigated and finally a novel route was developed starting from tetrakis(trimethylsilyl)silane, the mechanism for which was investigated. This new robust and reproducible synthesis involved a halogen-metal exchange and exploited a Schlenk equilibrium and was used to produce phenyltris(trimethylsilyl)silane in high yield (~70 %) on scales of up to 20 g.

Phenyltris(trimethylsilyl)silane was used as the starting material for the synthesis of silene precursors; 1-hydroxyalkylphenyltrisilanes (silyl alcohols), involving KO^tBu-mediated formation of phenyltris(trimethylsilyl)silylpotassium, transmetallation to the silylmagnesium bromide and addition of an aldehyde. Following optimisation and mechanistic studies on this reaction, it could be employed in the synthesis of several alkyl-analogues.

Silenes were generated from the silyl alcohols by the modified Peterson olefination. Extensive optimisation and mechanistic studies led to a procedure that involved the use of ⁿBuLi as a base to cause a 1,3-Si, O TMS migration which was followed by the addition of catalytic amounts of lithium bromide to induce elimination of Me₃SiOLi to give the silene.

Silene generation in the presence of a diene afforded [4+2] silacycloadducts containing an alkene in the β-position to silicon, along with small amounts of ene products and silene dimers. The silacycles were formed with satisfactory diastereoselectivity with the major isomer constituting 70-80 % of the mixture. A range of dienes were screened for reaction with various silenes.

The resulting silacycles were shown to be useful synthetic intermediates by their conversion into lactones. This involved hydrogenation of the carbon-carbon double bond followed by a Fleming-Tamao oxidation to afford diols, initiated by protodesilylation of the Si-phenyl group. Subsequent TPAP, NMO oxidation of the diols produced the desired lactones from which NOESY and other NMR experiments were used to deduce the stereochemistry. In addition, silacycles without substitution on the carbon-carbon double bond could be converted into bishomoallylic alcohols by omission of the hydrogenation and direct Fleming-Tamao oxidation, thus exploiting the latent reactivity of the allylic silane.

Declaration

The work contained in this thesis was carried out in the Department of Chemistry, University of Durham or GlaxoSmithKline, Medicines Research Centre, Gunnels Wood Road, Stevenage, Herts. between October 2000 and December 2003. All the work is my own unless otherwise indicated. It has not previously been submitted for a degree at this or any other university.

Copyright

The copyright of this thesis rests with the author. No quotation from it should be published without their prior written consent and information derived from it should be acknowledged.

1 Introduction

1.1 General Introduction

This research described in this thesis concerns the chemistry of silenes. These are highly unstable molecules which contain a silicon-carbon double bond. Since their discovery 35 years ago, the literature on silenes has grown enormously and several excellent reviews detail their formation, physical characteristics and reactivity.¹⁻⁶ Despite extensive studies, silenes have never been utilised in organic synthesis so this thesis addresses their application as novel synthetic reagents. More specifically, this involves their generation in the presence of dienes to furnish 6-membered silacycles **1**, Scheme 1. Elaboration of such silacycles followed by oxidative excision of the silicon unit yields synthetically useful building blocks such as **2**.

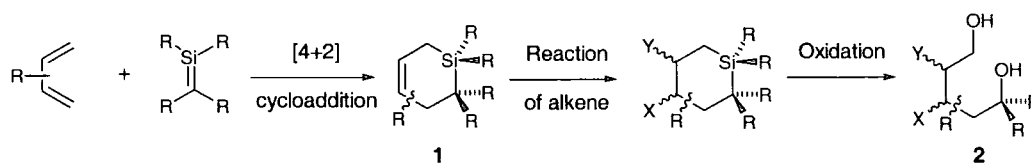

Scheme 1

This chapter firstly provides an overview of fundamental organosilicon chemistry and secondly acquaints the reader with the most important aspects of the history, generation and reactivity of silenes. In accord with the research undertaken, most emphasis is placed on the modified Peterson silene generation and the reactivity of silenes with dienes. Chapters 2 to 5 present and rationalise results, Chapter 6 concludes and Chapter 7 details experimental procedures.

1.2 Selected Aspects of Organosilicon Chemistry

1.2.1.1 Introduction

Silicon is in group 14 of the periodic table immediately below carbon. It therefore shows many similarities to carbon, such as having a valency of 4 and forming tetrahedral compounds.⁷ There are however, distinct differences between molecules containing either element and these have led to organosilicon reagents finding widespread use in organic synthesis.^{1, 8, 9} A brief discussion of the various ways that silicon differs from carbon and an overview of the main effects these have on the reactivity of a molecule are given in this section.



1.2.1.2 Bond Lengths

Bonds lengths to silicon are generally longer than equivalent bonds to carbon due to the increased atomic radius of silicon, Table 1.^{8, 10} An interesting result of this fact is that the trimethylsilyl group (TMS) is less sterically demanding than its *t*-butyl analogue. This can be attributed to the extra distance between the TMS group and the centre in question. For example, the steric requirements of both groups can be compared by examination of the A values ($-\Delta G$ values) of the substituted cyclohexanes, Scheme 2. Thus, interconversion between axial and equatorial conformations of TMS-cyclohexane is two times more favourable than that of *t*-butylcyclohexane.¹¹

Bond to C	Bond length /Å	Bond to Si	Bond length /Å
C-C	1.54	Si-C	1.89
C=C	1.32	Si=C	[1.72]
C-O	1.41	Si-O	1.63
C-Cl	1.78	Si-Cl	2.05
C-F	1.39	Si-F	1.60

Table 1

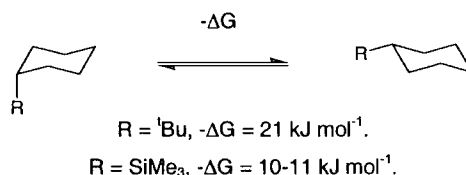

Scheme 2

1.2.1.3 Bond Strengths

In relation to the bond lengths, Si-C bonds are weaker than C-C bonds. Conversely, silicon forms much stronger bonds to electronegative atoms than does carbon, Table 2, with the Si-F bond being one of the strongest single bonds known.^{8, 10} This enhanced bond strength arises from an increased electrostatic interaction due to the low electronegativity of silicon.

Bond to C	Bond energy /kJ mol ⁻¹	Bond to Si	Bond energy /kJ mol ⁻¹
C-C	334	Si-C	318
C=C	620	Si=C	490
C-O	340	Si-O	531
C=O	720	Si=O	(Non-existent)
C-Cl	335	Si-Cl	471
C-F	452	Si-F	808

Table 2

As can be deduced from the data given in Table 2, the stable C=C double bond is almost equivalent in energy to two C-C single bonds. In contrast, the unstable Si=C double bond is 146 kJ mol^{-1} weaker than two Si-C single bonds. This weakness can be rationalised in several ways,³ notably:

1. Silicon has a large atomic radius, thus the distance between the atoms is large, which leads to poor sideways overlap of the p-orbitals, Figure 1.
2. The relatively low electronegativity of silicon means it has a weaker attraction for bonding electron density.
3. There is poor overlap of the carbon 2p and the silicon 3p orbitals due to mismatched energy levels and the more diffuse nature of the silicon 3p orbitals, Figure 1.

As a consequence of this, silenes are highly reactive and likely to undergo any reaction available in order to form two single bonds. For example, they decompose instantly on contact with atmospheric moisture or oxygen and, in the absence of other reagents, are prone to dimerisation.

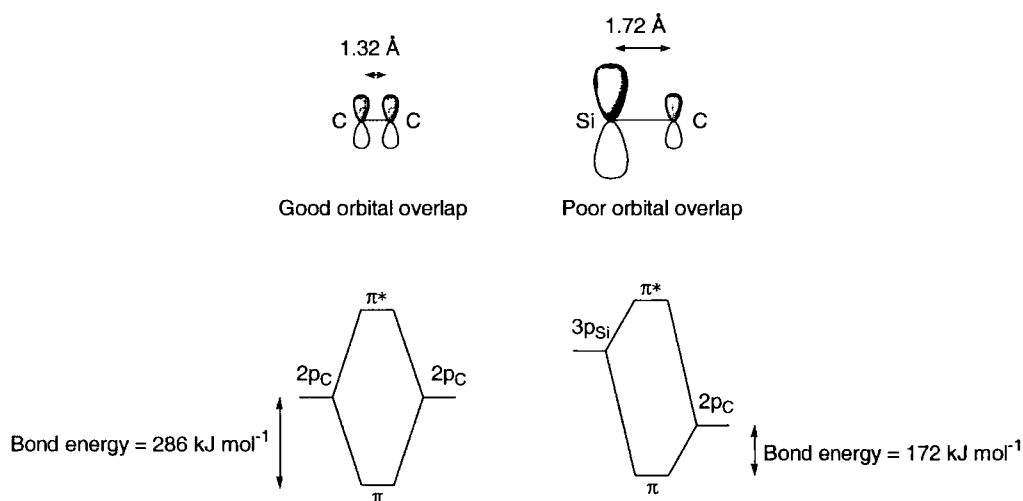
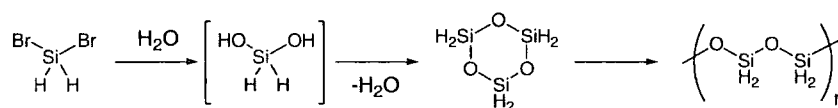

Figure 1

Furthermore, the carbonyl group is a highly stable double bond with an energy more than twice that of two C-O single bonds. Conversely, the Si=O double bond is non-existent on account of the very high strength of two Si-O single bonds. Hence, all attempts to generate molecules containing a Si=O double bond have resulted in preferential formation of silicones, Scheme 3.³



Scheme 3

1.2.1.4 Inductive Effects

Silicon has sometimes been referred to as a mild metal, and indeed many of the reactions undergone by organosilicon compounds can be attributed to this characteristic.^{9, 12} It is an inductive electron donor to carbon (electronegativities: Si, 1.64; C, 2.35) and so forms polarised bonds, of the form $\text{Si}^{\delta+}-\text{C}^{\delta-}$ or $\text{Si}^{\delta+}=\text{C}^{\delta-}$ in the case of silenes. Such molecules are therefore susceptible to nucleophilic attack at the silicon centre and such reactions with silenes mirror those with carbonyl groups which are polarised $\text{C}^{\delta+}=\text{O}^{\delta-}$. Silicon is also less electronegative than hydrogen, forming $\text{Si}^{\delta+}-\text{H}^{\delta-}$ polarised bonds, a feature which is exploited by such reactions as reduction by Et_3SiH .

1.2.1.5 Nucleophilic Substitution at Silicon

In contrast to carbon compounds, tetrasubstituted silicon can undergo apparent $\text{S}_{\text{N}}2$ substitution. The properties of silicon that facilitate this are the long Si-R bonds which provide space for a nucleophile to enter and the presence of low-lying d-orbitals which are free from the geometric constraints of σ^* orbitals. The pathway for nucleophilic substitution at silicon therefore involves formation of an intermediate pentacoordinate 'ate' complex such as **3** and is described as the $\text{S}_{\text{N}}2\text{-Si}$ mechanism, Scheme 4.⁸ This is in contrast to the carbon $\text{S}_{\text{N}}2$ reaction where there are no intermediates, only a pentacoordinate transition state.

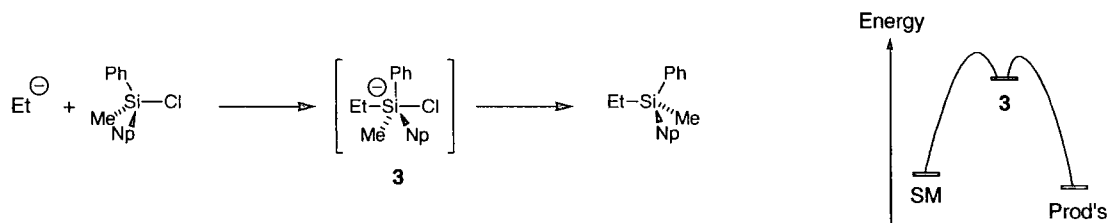

1.2.1.6 Stabilisation of α -Carbanions and β -Carbocations

The presence of silicon stabilises a carbanion in the α -position.⁸ This is attributed to two effects; firstly, overlap of the C-M bond with silicon d orbitals and secondly, overlap of the C-M bond with the adjacent σ^* antibonding orbital between Si and C, Figure 2. This second effect is particularly strong due to the large coefficient of this σ^* orbital on silicon.

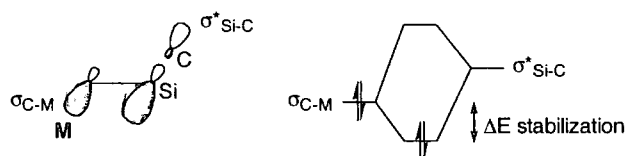

Silicon also stabilises β -carbocations so that allyl-, aryl-, vinyl-silanes and silyl enol ethers react with electrophiles in such a way as to leave the resulting positive charge β to silicon,

Scheme 5. The stabilising effect is a result of overlap between the vacant p orbital on carbon and the adjacent σ bonding orbital between Si and C. The effect is strong because this orbital has a large coefficient on carbon because carbon is more electronegative than silicon.

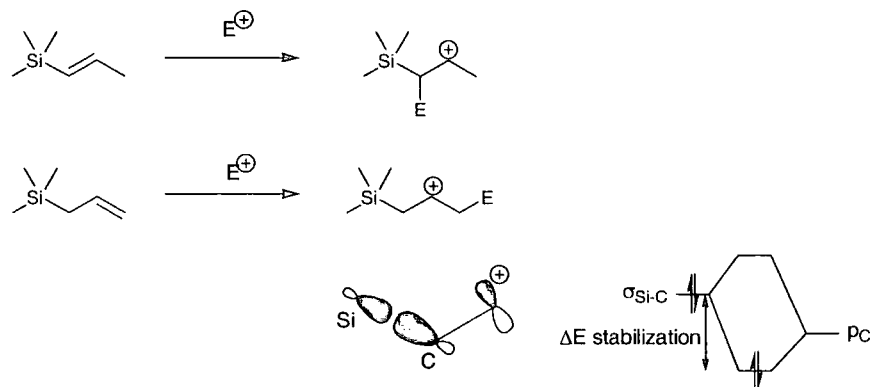

Scheme 5

1.3 History of Silenes

1.3.1 Initial Discoveries

According to West,⁶ research into molecules with novel bonding tends to follow the same sequence of events: i) evidence for the transient existence of such a molecule, ii) direct detection and characterisation by holding the reactive molecule at extremely low temperatures and iii) synthesis of the molecule with appropriate substituents to render it stable at RT. This progression has certainly been followed for silenes and their history is summarised in a review by Gusel'nikov.³ A concise account of the major advances is given here.

There were several early attempts to synthesise compounds with a Si=C double bond and thus fulfil the requirement for proof of their existence. The first was reported in 1912 when Schlenck and Renning believed they had synthesised silene **4** by the sequence shown in Scheme 6.¹³ The elimination of water from the reaction indicated dehydration of **3** to give silene **4**. However, a later study by Kipping showed that the water had arisen from an intermolecular condensation reaction of **3** to give siloxane **5**.¹⁴

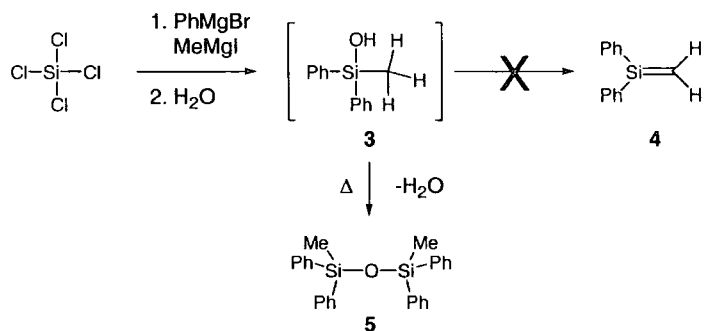

Scheme 6

Since formation of a silene seemed unfavourable in contrast with side reactions, West hoped to synthesise a molecule containing a Si=C double bond by exploiting the stabilising effect of aromatic resonance to encourage generation of sila-benzene **7**. Unfortunately, attempts at catalytic dehydrogenation of silacyclohexane **6** led only to recovery of starting material, Scheme 7.¹⁵

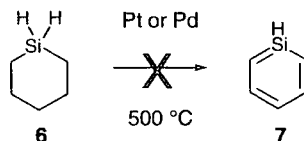

Scheme 7

Ultimately, proof of the existence of silenes was established in 1967 when Gusel'nikov and Flowers reported the generation of a silene as an intermediate during the pyrolysis of dimethylsilacyclobutane **8**.¹⁶ The observed production of ethylene and 1,3-disilacyclobutane **10** were explained as arising from retro [2+2] cycloaddition to afford **9**, which then underwent [2+2] silene dimerisation, Scheme 8. Further evidence for the intermediacy of a silene included the fact that the addition of water completely inhibited formation of **10**, leading instead to a mixture of trimethylsilanol **11** and hexamethyldisiloxane **12**. These products arise from the nucleophilic attack of water on the silene and subsequent siloxane formation.

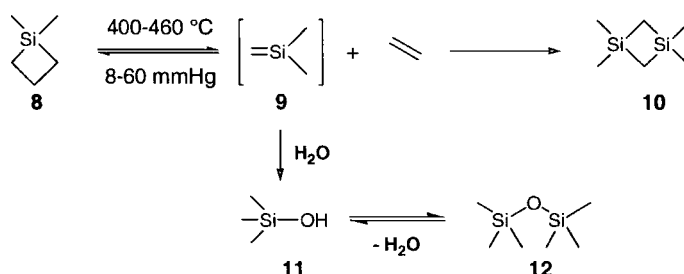

Scheme 8

The next major development was the direct detection of silenes at very low temperatures. In 1976 three groups isolated silenes in an argon matrix at 8-20 K and were able to record their IR spectra. Mal'tsev employed the same thermolysis discovered by Gusel'nikov and Flowers, Scheme 8, but trapped the products by condensation in argon.¹⁷ Three IR bands with wavelengths of 643, 825 and 1004 cm⁻¹ were observed and attributed to silene **9**. Later work on this reaction established that the band at 1004 cm⁻¹ arose from the Si=C stretch.^{18, 19} On increasing the temperature, dimer **10** was formed, providing further evidence that the trapped product was silene **9**. The other two groups of Chedekl and Chapman independently employed photolysis of silyldiazomethane **13** to generate the silyl carbene **14** which rearranged *in situ* to produce the observed silene **15**, Scheme 9.^{20, 21} The spectra were very similar to that of trisubstituted ethylene suggesting that the species was the planar silene **15**. Nevertheless, the groups were unable to assign an Si=C stretching frequency.²² Again, above

45 K, the silene dimerised to afford silacyclobutane **16** which lent further support to the existence of the silene.

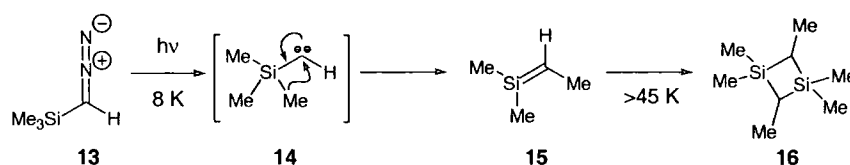

Scheme 9

The further evolution of silene chemistry provided methods which facilitated the synthesis of stable molecules. The first to succeed in this was Brook during research into the generation of silenes by photolysis of acylpolysilanes. During these investigations it became evident that the steric bulk of the substituent on carbon was significant in determining the reactivity of the silene. Building on this, it was found that pivaloylpolysilane **17** yielded a *relatively* stable silene **18** from which NMR data was obtained. It was described as only ‘relatively stable’ because it was in equilibrium with its dimer **19** and after 2 weeks reverted to the precursor **17**, Scheme 10.²³ Further work replaced the *t*-butyl group with adamantyl and, in 1981, it was found that photolysis of adamantoyltris(trimethylsilyl)silane resulted in a yellow solution of the stable silene **20**. Evaporation and recrystallisation from ether produced ‘off-white needles’ which enabled structural determination of **20** by X-ray diffraction.^{24, 25} The Si=C double bond was found to be 1.764 Å in length, considerably shorter than the Si-C single bond length of 1.87-1.91 Å. Molecular orbital calculations for unsubstituted silenes put the length at 1.69-1.71 Å,²⁶ but the difference in this case can be attributed to the lengthening effect of the oxygen substituent which makes **20**, in effect, a silyl silenol ether. NMR experiments up to 60 °C showed no broadening of the peaks indicating no rotation occurs about the Si=C bond. Although, the silene is kinetically stable with regard to dimerisation it is still highly reactive in the presence of other reagents. For example, Brook states that a sample of silene **20** is “unchanged after several years although if exposed to air disappears in a puff of smoke”.²⁷

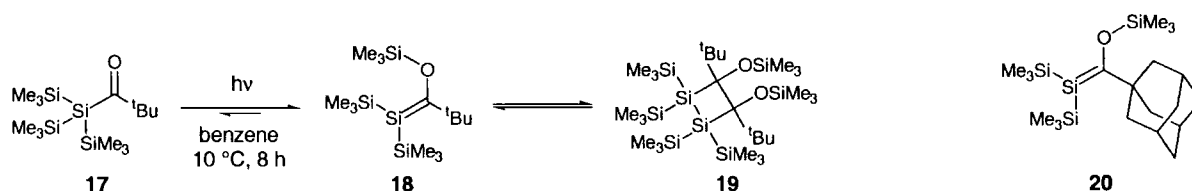

Scheme 10

In summary, silenes were hypothesised to be existent by analogy to alkenes. However, attempts to synthesise them in similar fashions to alkenes gave rise to the realisation that they must in fact be highly unstable molecules. Nevertheless, their transient existence was eventually proven in 1967 and they were subsequently detected directly in a low temperature

argon matrix in 1976. Evidence for their existence culminated in 1981 with the isolation of a stable silene crystal. Since that time, numerous novel stable silenes have been produced and these will be discussed in the next section.

1.3.2 Stable Silenes

Silenes, by nature, are not thermodynamically stable with respect to their reaction products. The most likely reaction, in the absence of any reagents, is dimerisation. Brook evoked the principle of using steric bulk to provide sufficient barriers to such reactions when he produced the first stable silene **20**. Several groups have employed this technique and examples of most stable silenes to date are described in Table 3. Later work by Wiberg showed that another method was available for the stabilisation of silenes. This involved providing an electron donor molecule to stabilise the electrophilic silicon atom. This technique was discovered when X-ray crystallography revealed a molecule of THF coordinating to the electrophilic silicon atom of silene **21** which was adding to its stability, Scheme 11.²⁸ Further work by Wiberg used trimethylamine, pyridine or fluoride to stabilise a simple silene such as **22**.²⁹ Without the donor amine, silene **22** was unstable even at $-100\text{ }^{\circ}\text{C}$, but with donation existed up to $0\text{ }^{\circ}\text{C}$.³⁰ As can be seen, the silene is without steric congestion implying it is only the electron donation which renders it stable.

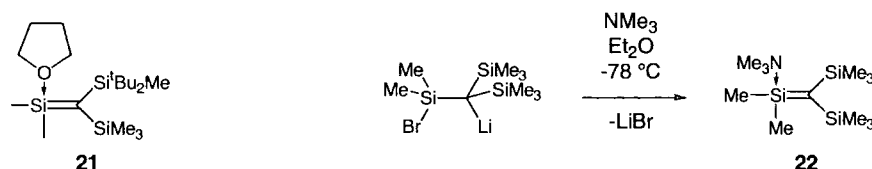

Scheme 11

Very recently, Oehme elegantly extended this principle by incorporating intramolecular amine electron donors into silenes. Thus salt elimination from polysilyl-dichlorides **23** afforded stable silenes **24a-c**, *via* a multistep mechanism (see Section 1.4.5, page 16), and X-ray crystallography allowed assignment of their structures, Scheme 12.³¹⁻³³ Importantly, the N atom was shown to be only 2.035-2.069 Å from Si=C supporting the concept of its participation in stabilisation.

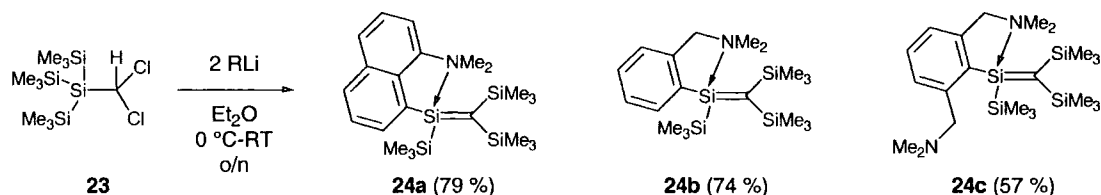

Scheme 12

Table 3 summarises the physical characteristics of the stable silenes. The calculated bond length of an unsubstituted silene is 1.69-1.71 Å. Silene **20** is somewhat an anomaly in all

fields due to the oxygen substituent. As already discussed, its bond length is increased by the donation effect of the oxygen. Consistent with this, the low chemical shift of the silicon atom in the double bond shows it to be highly shielded whereas that of the carbon atom implies it is highly deshielded by the adjacent electronegative oxygen. Silene **25**, by contrast, has a bond length in excellent agreement with the calculated values. The low chemical shift of the sp^2 carbon atom in **25** is indicative of the polarity of the silene and thus build-up of electron density on carbon. However, the chemical shift is much lower than that in silenes **26** and **28**, which have alkyl substituents on carbon, so the electropositive silyl groups must be adding to the effect. Furthermore, silene **25** is described as 'lying at the limits of isolability'; dimerisation taking place after a few days at RT. It is thought the higher reactivity of **25** compared with **20** is explained by the lack of a stabilising oxygen substituent. The difference seen in the chemical shifts of **26** can be attributed to the aromatic substituents on silicon. Silene **28** has the reverse substitution pattern of silene **25**, ie. silyl substituents on silicon and alkyl groups on carbon. As can be seen, this has greatly deshielded the sp^2 carbon and shielded the sp^2 silicon atom. Silatriafulvene silene **29** exhibits wildly different chemical shifts compared with the other silenes due to a reversal of polarity. This arises because of the inclination of triafulvene to support a positive charge, thus leaving electron density on silicon. The Si=C bond length of **24c** is slightly lengthened by N donation, but is otherwise in agreement with other silenes. Both silicon and carbon are highly shielded by this N donation giving them lower chemical shifts. This NMR evidence suggests that silene **24c** may be more like a silyl-carbanion aminocation zwitterion than a silene, particularly since such a carbanion would be stabilised by three α silyl groups.

Silene	Si=C bond length / Å	Si= ¹³ C NMR /ppm	²⁹ Si=C NMR /ppm	Ref.
20 	1.764	214.2	41.4	24
25 	1.702	77.20	144.2	28, 34-36
26 	-	110.44	77.6	37, 38
27 	-	-	79.6	31
28 	1.741	196.84	51.7	39-41
29 	1.755	159.9	-71.9	42
24c 	1.759	17.5	29.5	32

Table 3

Overall, the attributes of silenes can be said to depend heavily on their substituents. However deviations from theoretical calculations of simple models or the 'simple' silene **25** can be rationalised in terms of electronic effects of the substituents.

In conclusion, the drive to prove the existence of silenes and investigate their attributes has generated a wealth of information about their structure and spectroscopy. Furthermore, this research has produced a myriad of techniques for their generation and described numerous reaction pathways. Examples of many of these will be described in the subsequent sections.

1.4 Generation of Silenes

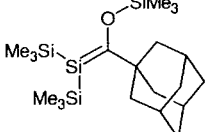
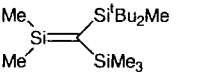
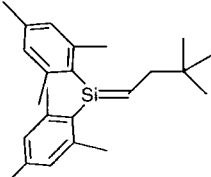
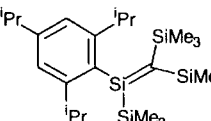
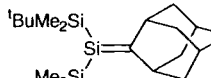
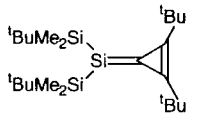
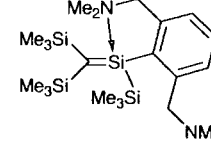
1.4.1 Introduction

Silenes are high-energy molecules so in order to synthesise them, large amounts of energy must be applied to the reaction mixture. A plethora of techniques have been described in the literature for achieving silene generation and these can be divided according to the method of providing the reaction energy; heat by gas-phase pyrolysis or solution-phase thermolysis, light by photolysis and chemical energy by salt elimination reactions, including the modified Peterson reaction. The subject has been extensively reviewed so only brief overviews of each method are given here.¹⁻⁵ However, a detailed review of the modified Peterson olefination will be given since this was the technique employed during the work described in this thesis.

The synthesis of silenes is complicated by the fact that they may have only transient lifetimes. Hence, the majority of research utilises trapping experiments to prove silene generation and give an idea of yield. Trapping can be achieved by introduction of reagents, such as dienes and nucleophiles, to the reaction mixture prior to silene generation or by allowing the silenes to dimerise. These reactions are discussed in detail in Section 1.5.

1.4.2 Gas-phase Pyrolysis Reactions

These reactions involve the thermal rearrangement or decomposition of compounds in the gas-phase to generate silenes. The very first example of such a method was employed by Gusel'nikov and Flowers in 1967 to provide the first evidence for the existence of silenes.¹⁶ As discussed in Section 1.3.1 (page 6), this involved the retro [2+2] cycloaddition of a disilacyclobutene. There are many more examples of similar retro [2+2] cycloadditions. Very low pressure pyrolysis of disilacyclobutane **30**, for instance, yielded a high molecular weight polymer on chemical deposition which was attributed to the intermediacy of disilene **31**, Scheme 13.⁴³

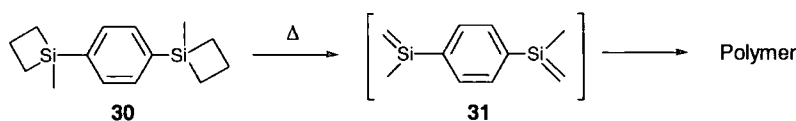

Scheme 13

In a similar manner, silenes have been generated by retro [4+2] cycloaddition, one of the most successful being the pyrolysis of substituted silabicyclo[2.2.2]octadienes such as **32**, Scheme 14.⁴⁴ Generation of silene **34** is favourable because the by-product is the aromatic compound **33**.

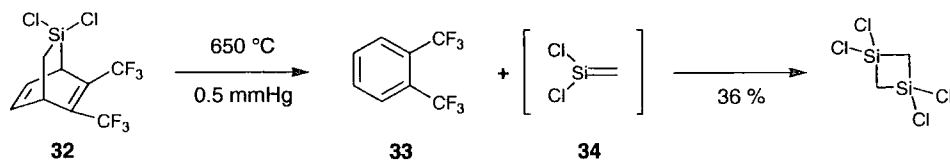

Scheme 14

A considerable amount of research has been conducted on the retro-ene fragmentation of allylsilanes such as **35** to generate silenes. For example, pyrolysis of **35** in the presence of methanol gave methoxy silane **36** as a result of generation of silene **9** followed by alcohol trapping, Scheme 15.⁴⁵

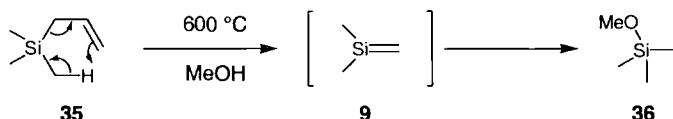

Scheme 15

Other pyrolysis reactions that generate silenes include rearrangements of silylenes **37**, [1,5] sigmatropic shifts of silyldienes **38**, electrocyclic ring opening of disilacyclobutene **39**, elimination from fluorosilane **40** and dehalogenation of chlorosilanes **41** using potassium and sodium vapours, Scheme 16.¹²

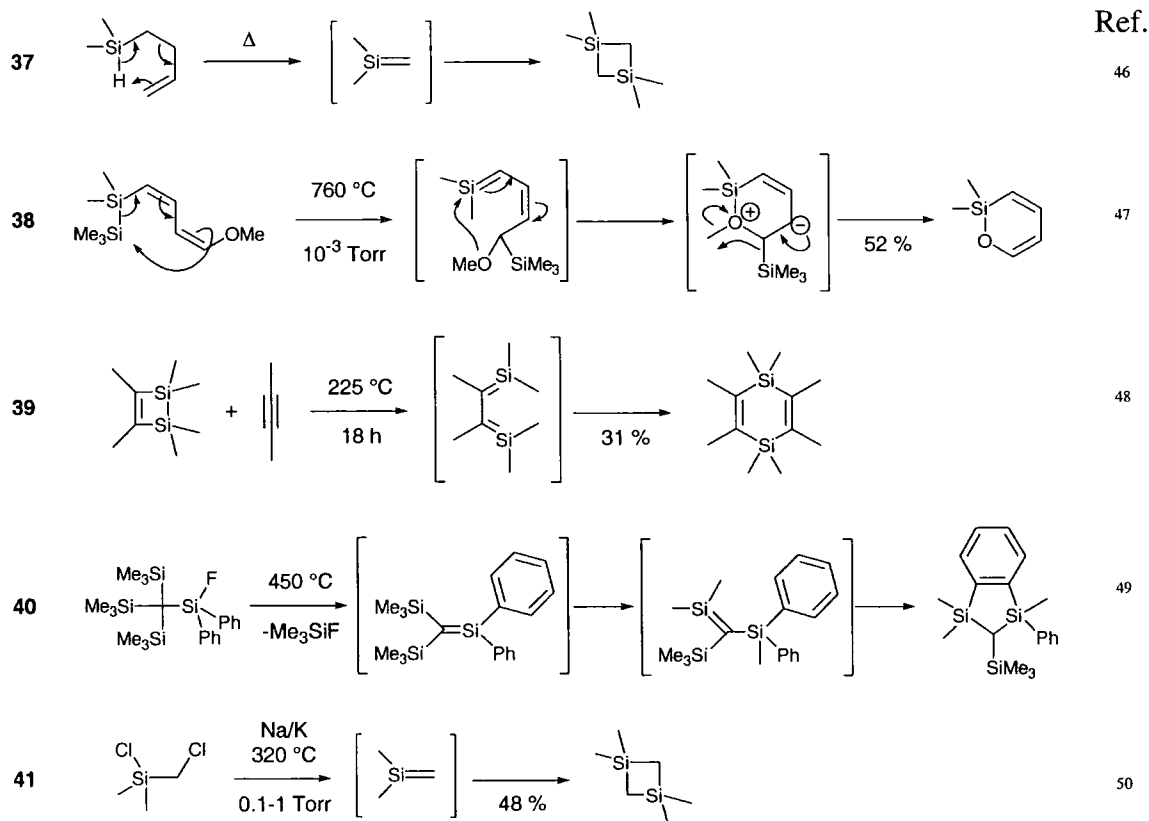

Scheme 16

1.4.3 Solution-phase Thermolysis Reactions

Many thermal silene generations in solution phase proceed *via* mechanisms similar to those of the pyrolyses described above. For example, on heating a solution of vinylsilane **42**, a sila-Cope rearrangement occurs to produce silene **43**. Intramolecular ene reaction of this yields the siloxycycle **44**, Scheme 17.⁵¹

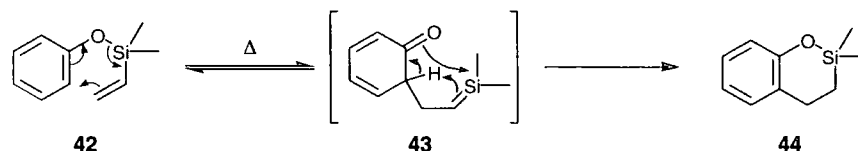

Scheme 17

Brook has carried out extensive research into silene generation by photolysis of acylpolysilanes which will be discussed in the subsequent section. However, it was also discovered that the reaction could be carried out in the dark by thermolysis. For example, thermolysis of neat acylpolysilane **17** in the presence of methanol caused rearrangement to silene **18**. This was trapped by the methanol to give the intermediate **45**. *In situ* methanolysis of this resulted in the formation of alcohol **46**, Scheme 18.²³

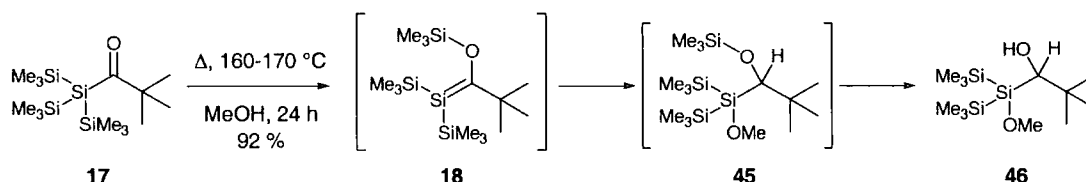

Scheme 18

An interesting, recent example of thermolysis has generated trisilacyclobutane **50** from disilacyclobutane **47**. This result is attributed to the simultaneous formation of a mixture of silene **48** and disilene **49** followed by their [2+2] coupling, Scheme 19.⁵²

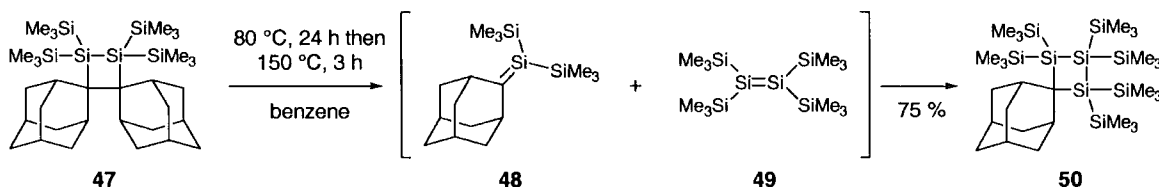

Scheme 19

1.4.4 Photolysis Reactions

Photolysis, like pyrolysis and thermolysis, is another method of providing sufficient quantities of energy to generate unstable transient intermediates. Many of the reactions are very similar to those covered under pyrolysis and thermolysis, involving rearrangements of stable starting materials.

Ishikawa initiated work on silene generation by photolysis of aryl and vinyl-disilanes such as **51**.⁵³ Various trapping experiments revealed that the transient silene **52** had been generated, probably as a result of the light-induced [1,3] sigmatropic shift of a silyl group, Scheme 20.

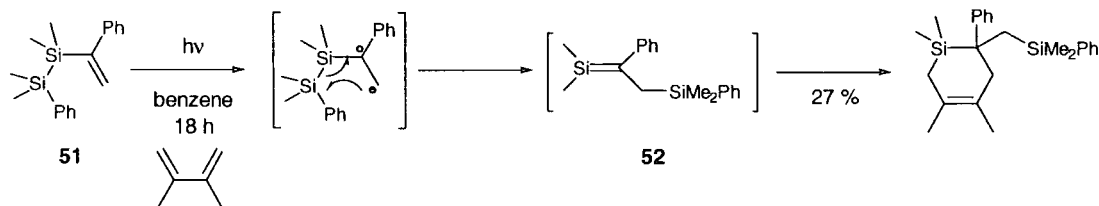

Scheme 20

One of the earliest methods for generating silenes was by the photolysis of silyl-substituted diazocarbonyl compounds, such as **53**, a discovery made by Ando and co-workers.⁵⁴ Photolysis of the diazo compound **53** in the presence of methanol gave the carbene intermediate **54**. Several reaction products were isolated, 19% of which could be attributed to a [1,2] methyl migration to give the silene **55**, followed by reaction with methanol to give methoxysilane **56**, Scheme 21.

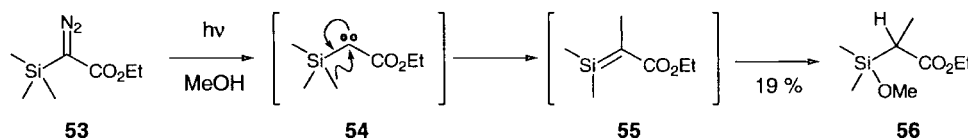

Scheme 21

Barton and Hoekman devised a simple synthesis of bis(trimethylsilyl)diazomethane **57** which on photolysis in benzene formed the head to tail and linear dimerisation products **59** and **60**, Scheme 22. This proved the existence of the transient silene **58**.⁵⁵

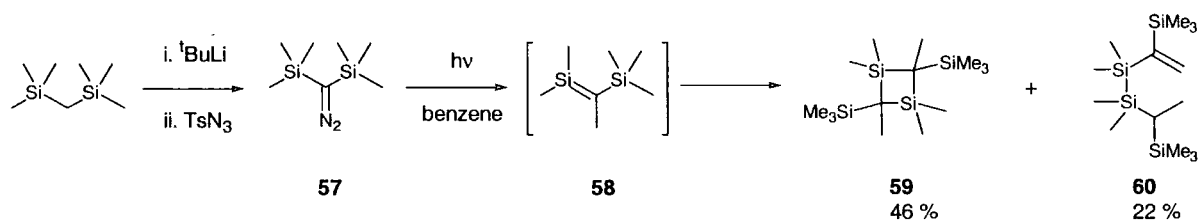

Scheme 22

The ability of acylpolysilanes to produce silenes on photolysis was first demonstrated by Brook in 1976.^{23, 27, 56} Thus acyldisilane **61** was photolysed in the presence of methanol to furnish methoxy silane **63**, Scheme 23. This was attributed to generation of the intermediate silene **62** followed by reaction with methanol.

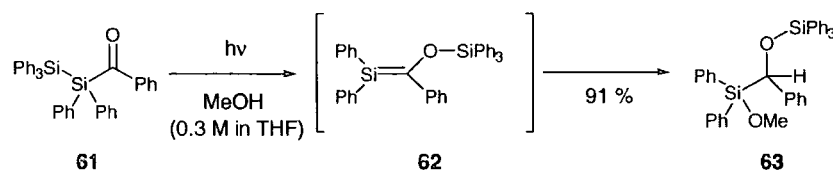

Scheme 23

Brook moved on to study the employment of tris(trimethylsilyl)acylsilanes **64** as precursors, Scheme 24.^{23-25, 27, 57} These were found to form silenes much more readily due to the availability of three TMS groups for the migration. Continued studies used various tris(trimethylsilyl)acylsilanes and culminated with the production of the stable adamantyl silene **20** described in Section 1.3.1 (page 7).

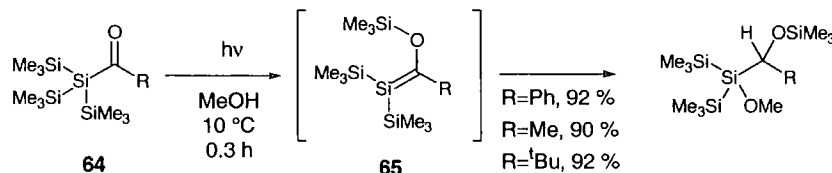

Scheme 24

Various other substrates can be used in photochemical reactions to generate silenes. Interesting examples include electrocyclic ring openings of silacyclobutenes **66** and silacyclohexadienes **67**. Hydrogen atom abstraction in disproportionation reactions of silyl radicals **68** have also been shown to form silene intermediates, Scheme 25.¹²

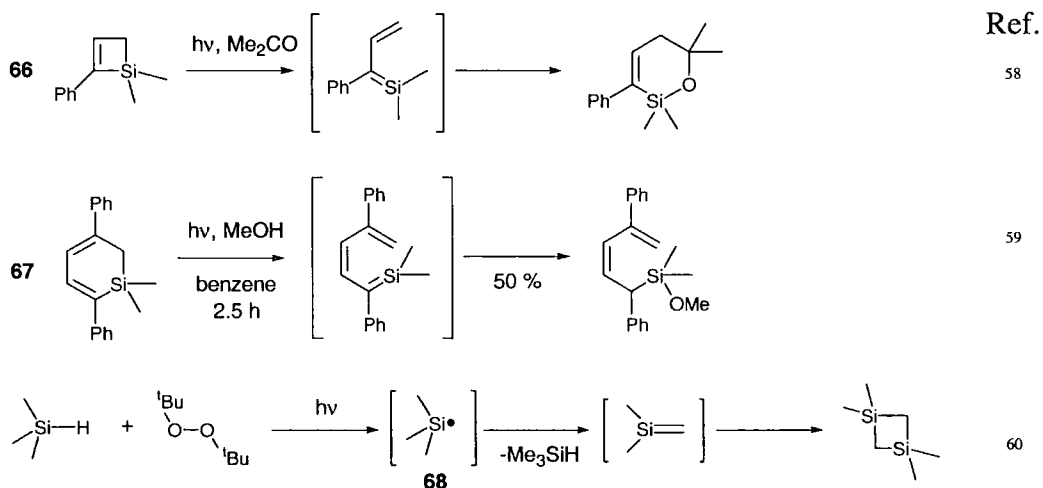

Scheme 25

1.4.5 Salt Elimination Reactions

Another method of providing sufficient quantities of energy to generate silenes is by the elimination of a salt. In this case, the reaction pathway is favourable due to the lattice energy released on salt precipitation. Jones accomplished this by addition of *t*-BuLi to the vinylchlorosilane **69**, Scheme 26.⁶¹ *t*-BuLi is sufficiently hindered to undergo 1,4-nucleophilic addition rather than attacking silicon directly. Thus, the lithiated intermediate **70** was generated and underwent elimination of LiCl to produce neopentyl silene **71** identified as its dimerisation products or by diene trapping. Auner has made extensive use of this technique to study the reactions of silenes with dienes and this work is discussed in Section 1.5.3 (page 28). Furthermore, it has been employed by Couret to synthesise the stable neopentyl silene **26** discussed in Section 1.3.2 (page 9).^{37, 38}

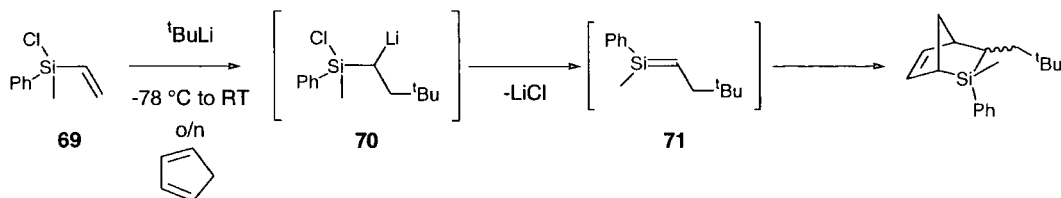

Scheme 26

Similarly, Wiberg synthesised various silyl-lithiums **73** by treatment of the parent bromosilanes **72** with BuLi, Scheme 27.⁶² These intermediates underwent salt elimination to furnish the intermediate silene **74** identified by its dimerisation products **75** or diene trapping experiments. Investigation of reaction rates revealed elimination of LiOTs to be the fastest reaction and LiF one of the slowest, which is to be expected on account of breaking one of the strongest single bonds known, the Si-F bond. This technique was used by Wiberg to synthesise the stable silene **25** discussed in Section 1.3.2 (page 9).^{28, 34}

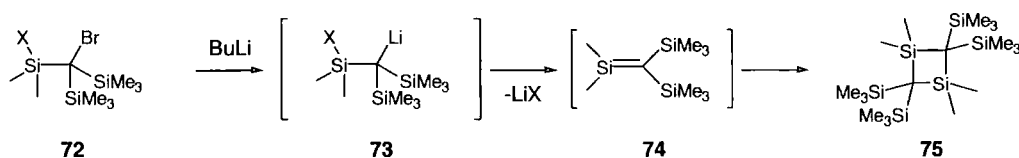

Rate of reaction : X=OTs > Cl > Br > I > OPO(OPh)₂ > SPh = F > OP(OPh)₂

Scheme 27

Finally, a recent fascinating example of silene generation by salt elimination has been described by Oehme.³¹ Treatment of dichloroalkylsilanes **76** with 3 equivalents of alkyl lithium caused the substrate to undergo a multi-step mechanism involving loss of 2 equivalents of LiCl and generation of 2 transient silenes to ultimately furnish, on work-up, silanes **77**, Scheme 28. Oehme employed this methodology to synthesise stable silenes **24a-c** seen in Section 1.3.2 (page 8).

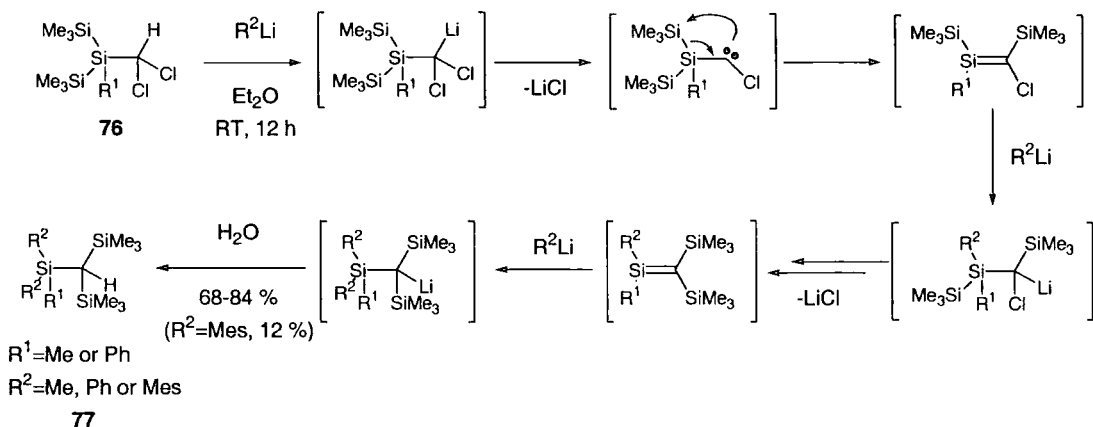

Scheme 28

1.4.6 Modified Peterson Olefination

1.4.6.1 Introduction

The modified Peterson olefination is a solution phase, low temperature method for the generation of silenes. It can be adapted to form silenes from a range of substrates and the resulting silene can be trapped by reaction with a variety of trapping agents. In consideration of these attributes it was chosen for the research that this thesis describes. Accordingly, this section covers in detail the research published to date on the modified Peterson silene generation.

1.4.6.2 Peterson Olefination

The original Peterson olefination, first reported in 1968, is a silicon analogue of the Wittig reaction used to generate alkenes.⁶³ The reaction is a two step process involving formation of a β -hydroxy silane followed by elimination. The precursor β -hydroxyalkylsilane **79** is synthesised by addition of trimethylsilylalkylmagnesium chloride to a carbonyl compound, Scheme 29. The resulting oxymagnesium chloride **78** is stable and provides **79** on work-up. The second step may be catalyzed by acid or base to give alkenes in high yield and, given the stereochemistry of the hydroxy precursor, the choice of catalyst determines the stereochemistry of the resulting double bond.⁸ For example, acid catalyzed elimination of the substrate **79** gives the *cis* alkene. This is a result of an *anti*-elimination because the antiperiplanar conformation is favoured due to maximum orbital overlap and minimum steric interactions between adjacent groups. Application of base to the substrate **79** produces the *trans* alkene as a result of *syn*-elimination. In this case, the synperiplanar relationship is necessary due to the formation of a 4-membered ring. The reaction sequence can be carried out as a 'one-pot' procedure by addition of trimethylsilylalkyl lithiums to carbonyl compounds instead of magnesium chlorides. This forms an oxylithium intermediate which is unstable and undergoes spontaneous elimination to give alkenes. Unfortunately, no stereoselectivity is accrued using this one-pot method and so gives a 1 : 1 mixture of *cis* and *trans* alkenes. Overall, the Peterson olefination has several advantages over the Wittig reaction. Firstly, the diastereoisomers of precursor **79** can be separated and then treated appropriately to give only the desired alkene geometry. Secondly, these precursors can be synthesised from bulky Grignard reagents, whereas the bulky triphenylphosphine group in the Wittig reaction limits the use of sterically hindered ylides. Finally, the triphenylphosphine oxide by-product of the Wittig reaction is very difficult to remove from the product mixture, whereas there are no such complications with the Peterson olefination. However, the choice

of substrate is limited in the Peterson olefination because Grignard reagents are considerably more basic than phosphorous ylides.

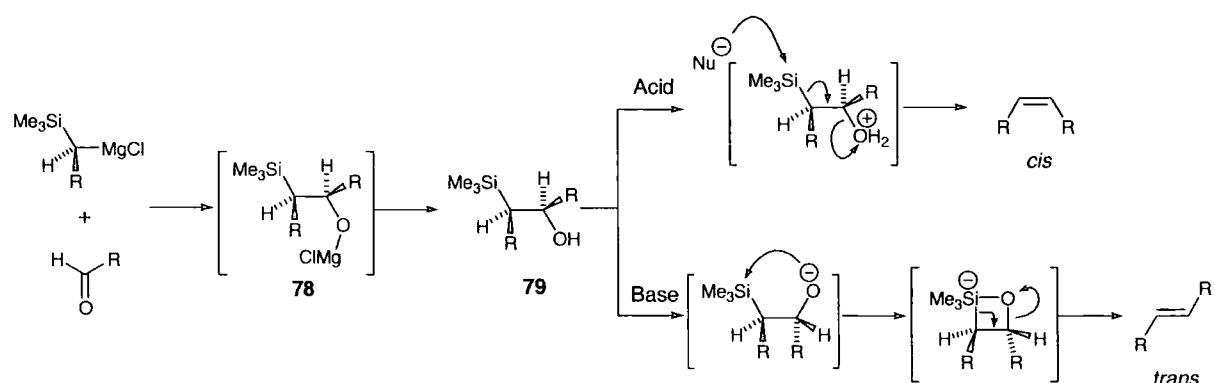

Scheme 29

1.4.6.3 Modified Peterson Olefination

The Peterson olefination is used to synthesise C=C double bonds, essentially by addition of a silylcarbanion to a carbonyl compound. However, replacement of the carbon atom in the nucleophile by other elements has been shown to allow synthesis of carbon-heteroatom double bonds. For example, Becker showed that treatment of carbonyl compounds with silylphospholithiums provided molecules containing P=C double bonds, Scheme 30.⁶⁴

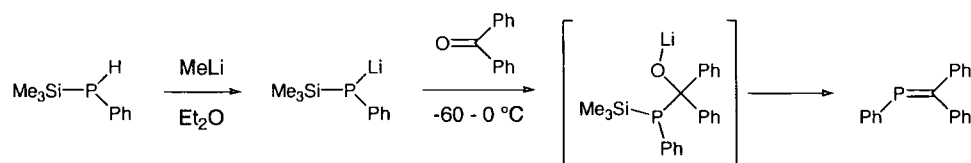

Scheme 30

By analogy to these studies, Oehme began investigating a hypothesis that Si=C double bonds could be generated by addition of disilyllithium reagents to carbonyl compounds.⁶⁵ Employment of such strategies has led to the modified Peterson olefination becoming a robust technique for the synthesis of silenes. In fact, three distinct variations have evolved, Scheme 31. The first, analogous to the one-pot Peterson olefination, involves addition of a polysilyllithium to a carbonyl compound (Eq. 1), the second addition of an alkyl-lithium to an acylpolysilane (Eq. 2) and the third, paralleling the original Peterson olefination, entails deprotonation of a hydroxyalkylpolysilane (Eq. 3). All three techniques involve passage through a common oxyanion intermediate. The development and attributes of each technique will be discussed in order.

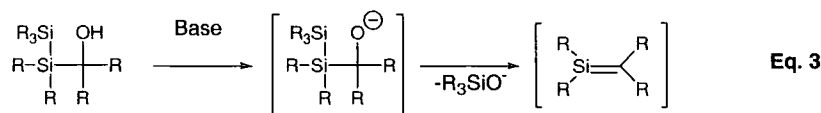
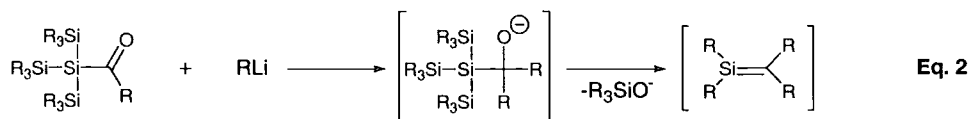
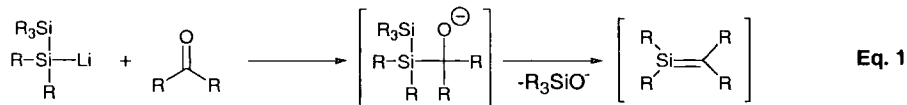

Scheme 31

• *Eq. 1 (Scheme 31)*

Initial experiments by Oehme involved the addition of tris(trimethylsilyl)silyllithium **80** to ketones in THF. However, these apparently failed to afford silenes. Instead, a rapid 1,4-Si,O-trimethylsilyl shift occurred to give silyllithium **81** which Oehme suggests was then protonated by another equivalent of enolisable ketone, before any elimination took place, to give **82**, Scheme 32.⁶⁵ However, inversion of the mode of addition, so that the ketone was added to polysilyllithium **50**, gave rise to the formation of a different product, ultimately assigned as polysilane **83**.^{*} This was isolated in varying ratios with **82** depending on the ketone used.⁶⁶ Polysilane **83** arises as a result of silene generation followed by nucleophilic addition of an extra equivalent of polysilyllithium and subsequent rearrangement.⁶⁷ This alternative pathway is followed under this inverse addition mode because there is no excess ketone to protonate the intermediate silyl-anion **81**.⁶⁸

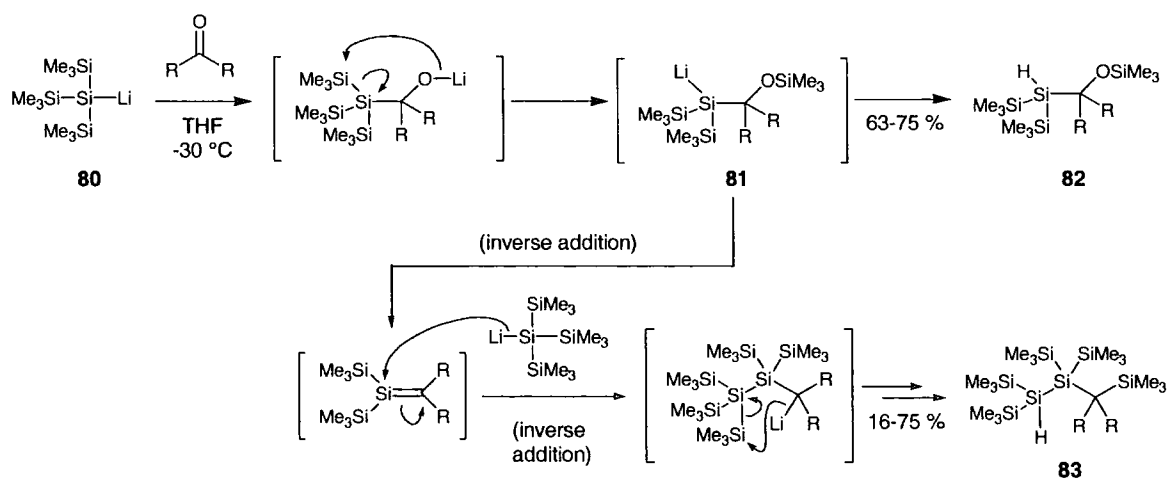

Scheme 32

* Initially, a different (incorrect) structure was assigned by Oehme and rationalised as the result of displacement of the trimethylsiloxy group by a second equivalent of polysilyl lithium (in a surprisingly facile reaction given the presence of a negative charge on silicon).

As can be seen, ketone enolisation limits the use of this strategy for silene generation. This problem has been circumvented by utilising non-enolisable ketones and by the use of solvents other than THF. For example, Apeloig employed adamantone as the ketone and conducted the reaction in non-polar solvents hexane or benzene. The bridgehead protons of adamantone are non-enolisable, hence on addition of tris(trimethylsilyl)silyllithium **80**, the silene **48** was generated and its corresponding dimer **47** isolated, Scheme 33.⁶⁹ However, use of enolisable 4-*tert*-butylcyclohexanone in these solvents also gave a silene **84** which underwent an ene reaction (see Section 1.5.2.4, page 27) with itself to produce the linear dimer **85**.⁶⁹ It is apparent that the non-polar solvents favour formation of non-polar intermediates and products so enolisation is no longer a problem. In both cases, dimerisation occurred rather than nucleophilic attack by more silyllithium. This can be attributed to either the formation of less polar intermediates in the former pathway which is favoured by non-polar solvents or slower silene generation from lithiated intermediates so no silyllithium **80** remains when silene is generated.

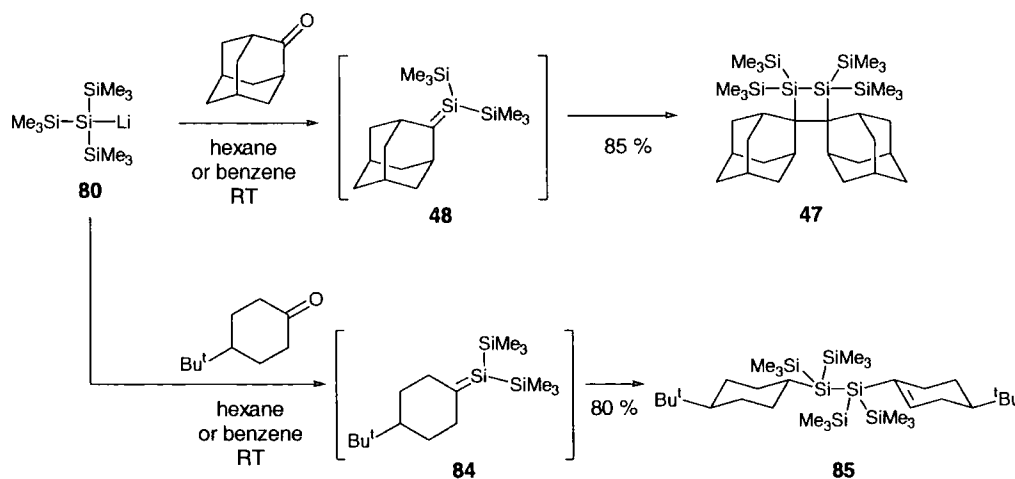

Re-investigation of Oehme's earlier work also showed the choice of solvent had a profound effect on silene generation and reaction. As described earlier, low temperature reaction of polysilyllithium **80** with eg. diethyl ketone, in THF gave **82** due to protonation of the silyllithium intermediate **81** by the enolisable ketone. However, when the reaction was done in ether, the linear silene dimer **87** was obtained, Scheme 34.⁷⁰ This indicated that **81** underwent elimination of trimethylsilanolate to form silene **86** before it could be protonated by the remaining ketone.

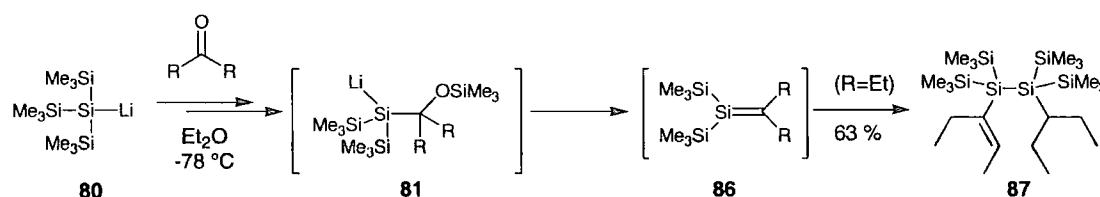

◦ *Eq. 2 (Scheme 31)*

Ishikawa later succeeded in generating silenes **89** in the second manner by addition of MeLi to acylpolysilanes **64** in ether, Scheme 35. The resulting oxanion underwent elimination of trimethylsilylanolate to give the silene which underwent [2+2] dimerisation.⁷¹ This reaction essentially follows the same mechanism as that given by Oehme above, both pathways passing through intermediate **88**. The reaction was applied to a range of substrates varying at R, but failed for R=^tBu. Instead, cleavage of the acyl-silicon bond occurred to eliminate tris(trimethylsilyl)silyllithium. This could be attributed to the increased steric bulk of ^tBu inhibiting elimination and leading to the preferential ejection of the hypersilyl group.

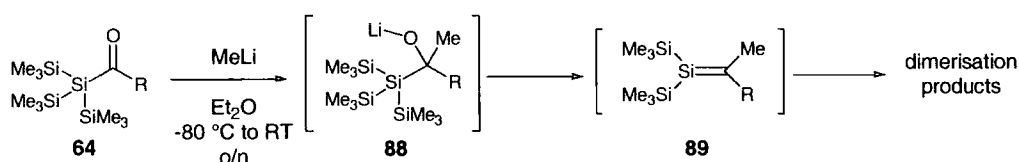

Scheme 35

An interesting result was discovered when Ishikawa and Ohshita added polysilyllithium **80** to acylpolysilane **64**. Instead of the expected addition to the carbonyl group followed by silene generation as described above, **80** abstracted a TMS group to leave a lithium silenolate **90** (an enolate analogue), Scheme 36.^{72, 73} This relatively stable molecule underwent apparent [4+2] addition with alkyl dienes indicating silene character although variable temperature NMR experiments showed rotation about the Si-C bond at RT indicating the bulk of the negative charge to reside on silicon leaving more C=O character.⁷⁴

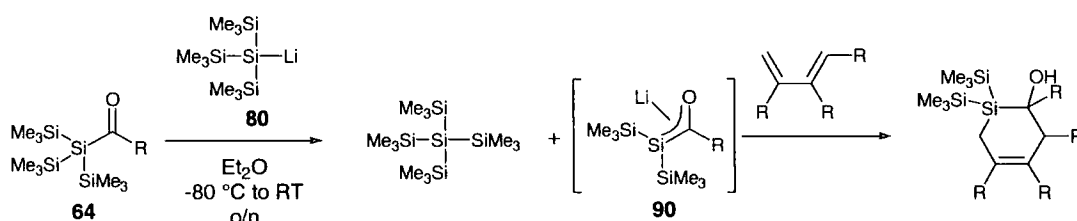

Scheme 36

• *Eq. 3 (Scheme 31)*

The methods involving *in situ* silene generation by addition of polysilyl-lithium anions to carbonyl compounds or alkyl-lithiums to acylpolysilanes have a disadvantage in that aromatic aldehydes and ketones undergo competing electron-transfer reactions.⁶⁶ In addition, although aliphatic carbonyl compounds do afford silenes, they may also be prone to enolisation. For these reasons, Oehme pioneered a third method of silene generation involving formation of a stable silene precursor, 1-hydroxyalkylpolysilane **93**, thus paralleling the regular Peterson olefination. On deprotonation, **93** undergoes the modified Peterson olefination and it was proposed that this technique would offer the possibility of a free choice of reaction medium and base.⁷⁵ Synthesis of the 1-hydroxyalkylpolysilanes **93** was done in an analogous manner

to the original Peterson olefination; tris(trimethylsilyl)silylmagnesium bromide **91** was reacted with carbonyl compounds in ether. The intermediate oxymagnesium bromides **92** were stable up until work-up after which **93** could be isolated, Scheme 37.^{68,76}

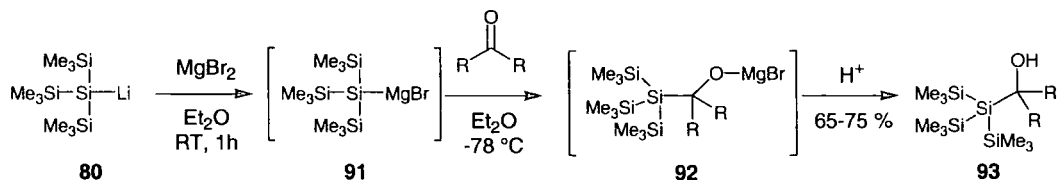

Scheme 37

Treatment of alcohols **93** with MeLi in ether at -78°C generated the silenes **86** which were detected as their dimerisation products and by diene trapping experiments, Scheme 38. However, Oehme discovered that if the reaction was done in THF or with NaH in ether or THF, then the siloxysilylalkanes **82** were generated on work-up and no silene products were detected. This is rationalised as follows; a 1,3-Si, O TMS migration gives the usual intermediate **94**. Under the first conditions, this undergoes elimination to afford the silene but under the latter conditions, no elimination takes place.⁷⁷ Oehme also showed that silenes could be generated by use of bases PhLi and ^tBuLi in ether which suggests that it is important for the counter ion of **94** to be lithium in order for elimination to take place. This can be rationalised in terms of the stability of the leaving group, Me₃SiOLi is more stable than Me₃SiONa because lithium is more electronegative than sodium. Furthermore, THF decreases the stability of such oxanions by coordination to the metal counterion, hence no elimination took place in THF. Finally, it should be noted that the use of two equivalents of alkyl-lithium resulted in addition of the second to the silene to give compounds **95**. This result confirms Oehme's early work on the addition of ketone to polysilyllithium in THF where silene was generated but addition of excess polysilyllithium followed immediately, Scheme 32.

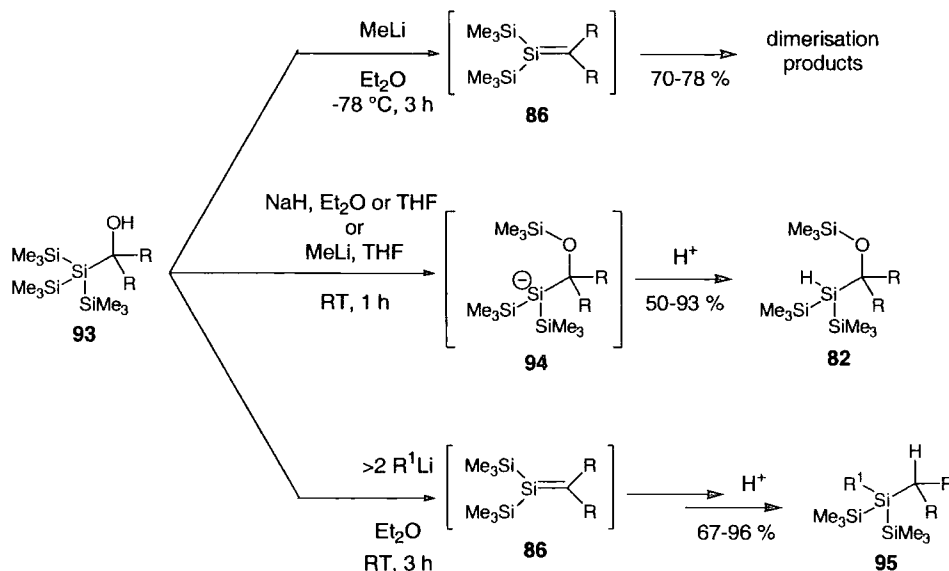

It was stated earlier that the 1-hydroxyalkylpolysilane precursors **93** were synthesised by addition of tris(trimethylsilyl)silylmagnesium bromide **91** to carbonyl compounds in ether because the intermediate oxymagnesium bromides **92** were stable until work-up. However, Oehme has shown that treatment of hydroxymesitylpolysilane **96** with PhMgBr in THF at RT does generate silene **97**, although it takes one week to do so, Scheme 39.⁷⁸ Moreover, silene generation was also found to occur as a side reaction during the synthesis of 1-hydroxymethyltri-isopropylphenylpolysilane **98** even though the reaction was carried out in ether.⁷⁹ This reaction was necessarily conducted at RT over 24 h. It can therefore be concluded that higher temperatures and longer reaction times allow the degradation of intermediate oxymagnesium bromides **92** to silenes.

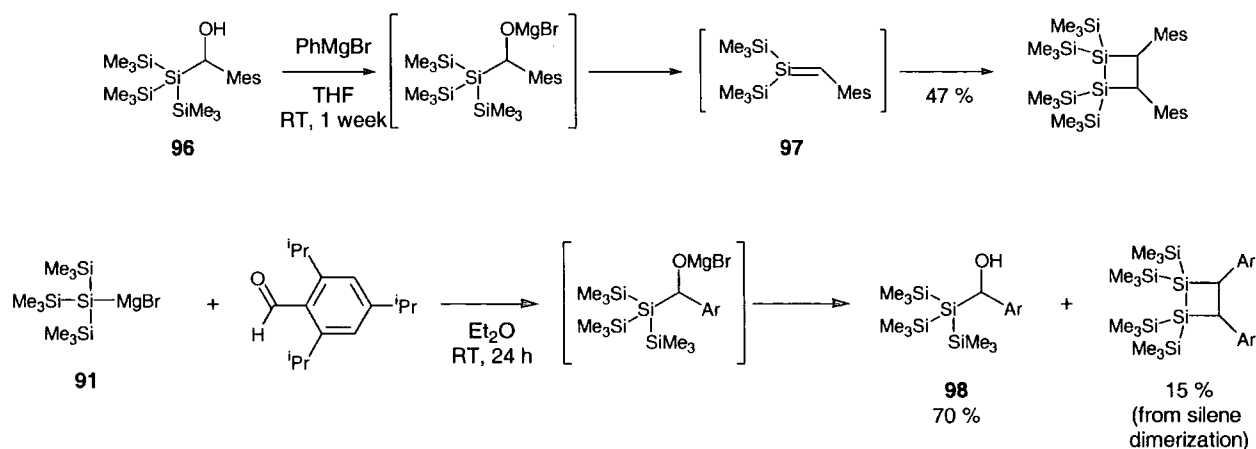

Finally, by analogy to the conventional Peterson olefination, the same elimination reaction should proceed using acid or base. Oehme has shown, however that acid does not give silene, but instead induces formation of a carbocation after loss of water. TMS migration then occurs

to leave the β -silyl silylium cation which affords silanol **99** on work-up, Scheme 40.^{80, 81} Also, nucleophiles other than water can be used to trap the silylium ion, such as MeOH or fluoride by use of anhydrous H₂SO₄ for the migration, then addition of the nucleophilic reagent.

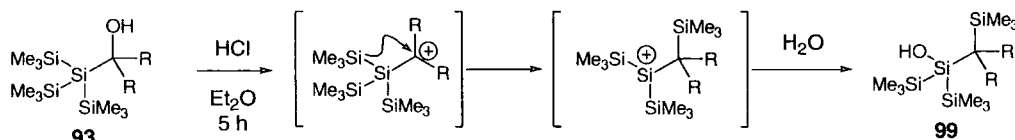

Scheme 40

In conclusion, the modified Peterson reaction provides a practical method for the low-temperature, solution-phase generation of silenes. In particular, by employment of silene precursors, 1-hydroxyalkylpolysilanes allows pre-mixing with the desired trapping reagent before treatment with base releases the silene. In consideration of this applicability to a synthetic methodology, the modified Peterson reaction was that chosen for the research this thesis describes.

1.5 Reactions of Silenes

1.5.1 Introduction

Many reactions of silenes were originally a means of providing evidence that the silene had been generated. However, as methods for the generation of silenes improved and became more robust, particularly with the advent of stable silenes, research has focused on screening their reactivity with a variety of reagents. Overall, silenes can be made to undergo dimerisation, cycloaddition, including ene reaction, and nucleophilic addition. Each type of reaction will be discussed, albeit with greater emphasis placed on their reaction with dienes, reflecting their relevance to this thesis.

1.5.2 Dimerisation

1.5.2.1 Introduction

If a silene is generated in the absence of any other reagents, it almost always reacts with itself to form dimers. In fact, this is often found to occur as a side reaction even when trapping reagents are present. The few exceptions are the stable silenes discussed in Section 1.3.2 (page 8) where steric effects hinder the process. Dimerisation has been reported extensively in the literature and is accepted as proof of the existence of a transient silene. Several examples of this reaction have already been seen in Section 1.4. The dimerisation can occur in three discreet ways; head to tail [2+2] addition, head to head [2+2] addition or by an ene type reaction, Scheme 41, and these will be discussed in turn. Despite the mechanisms drawn

in Scheme 41, it should be noted that strong arguments exist against a concerted pathway and the reactions are thought to involve radical or ionic intermediates.

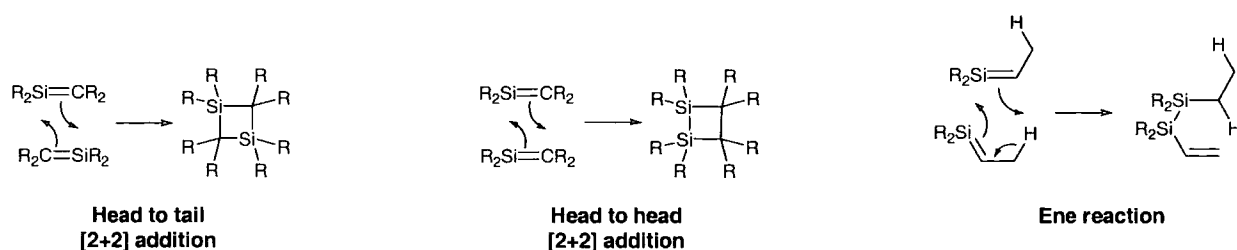

Scheme 41

1.5.2.2 Head to Tail Dimerisation

Gusel'nikov and Flower's very first proof that a silene could exist came from the identification of its head to tail dimer.¹⁶ In fact, the polarisation of silenes in the form, $\text{Si}^{\delta+}=\text{C}^{\delta-}$, makes head to tail dimerisation more favourable than the head to head addition. As a result of this, it is the most common dimerisation described in the literature and some examples are given in Scheme 42.

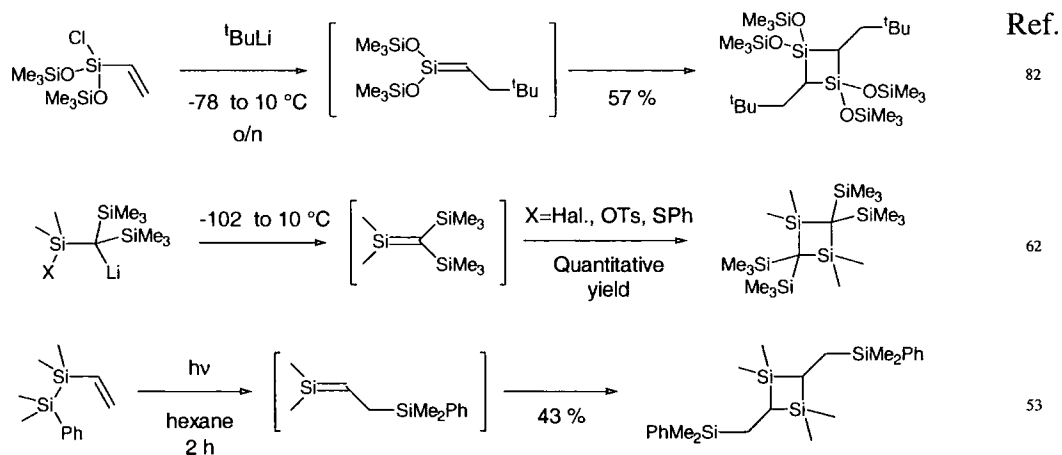

Scheme 42

1.5.2.3 Head to Head Dimerisation

On photolysis of acylpolysilane **17**, Brook isolated the head to head dimer **19**, Scheme 43.²³ As described in Section 1.3.1 (page 7), this dimer, when in solution, was found to be in equilibrium with the relatively stable silene **18**. Furthermore, the solution gave rise to a strong ESR signal thought to arise from the diradical intermediate **100**, thus providing evidence for the stepwise dimerisation shown. Radicals on carbon atoms α or β to silicon are stabilised by the same effects as are α -anions and β -cations, described in Section 1.2.1.6 (page 4). The regiochemistry of this reaction can now be explained; coupling of the silicon atoms of two silene molecules leaves radicals on the carbon atom α to the polysilyl group. More importantly, this position is also β to the terminal silyl groups and therefore stabilised

by both effects. This lowers the energy of the head to head pathway sufficiently to become more favourable than the more usual head to tail coupling.

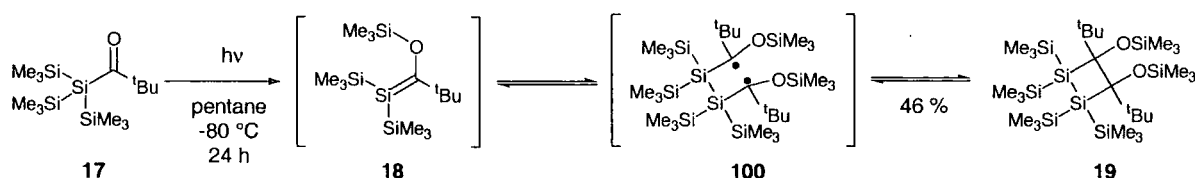

In fact, silenes with silyl groups on silicon mostly undergo head to head dimerisation reactions and further examples are given in Scheme 44.

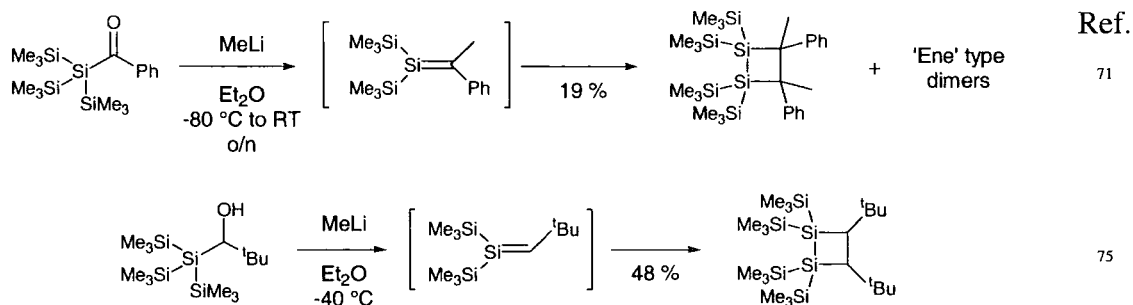

Exceptions to this rule have been discovered by Oehme. If the silene possesses an electron donor group, such as an amine, then the head to tail dimerisation is made more favourable.⁸³⁻⁸⁵ For example, silene **101** forms dimer **102**, Scheme 45. This is explained as the result of the amino group 'anchoring' the carbon end of one silene to the silicon end of the other as shown below.

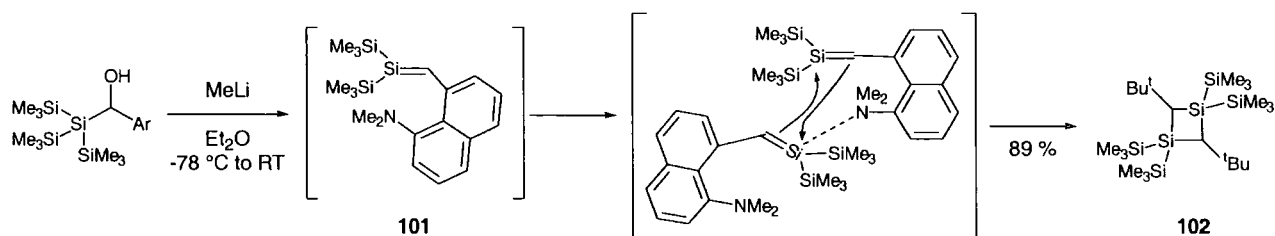

Finally, an interesting anomaly was found by Oehme in the form of silene **103**. This silene could be made to generate either dimer simply by utilising different solvents, Scheme 46.⁸⁶ This result is explained as follows; in toluene, the methoxy group of silene **103** anchors the silenes in a head to tail transition state as described above and results in formation of dimer **104**. However, the donating effect of the methoxy group in silene **103** is weak compared with the aminosilenes described earlier. Thus in ether, solvent molecules displace this group from anchoring interactions and the usual head to head dimerisation of silylated silenes takes place to afford **105**.

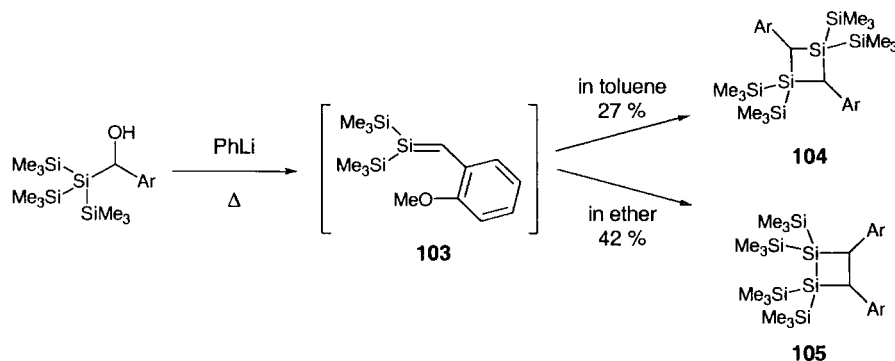

Scheme 46

1.5.2.4 'Ene' Type Dimerisation

Silenes which possess 'allylic' hydrogen atoms tend to dimerise to give products which arise from an ene reaction. For example, dimethyldisilyl silene **106** produces linear dimer **107**, Scheme 47.⁸⁵

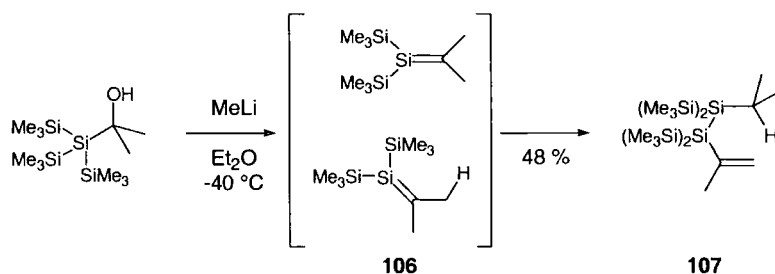

Scheme 47

These reactions are actually a kind of head to head dimerisation and a result of the diradical intermediate described earlier. Brook has proved this by ESR spectroscopy of the reaction mixture of photolysis of acetylpolysilane **108**, Scheme 48. Hence, the linear dimer **109** is a result of radical hydrogen abstraction, involving a 6-membered transition state, as shown.²³

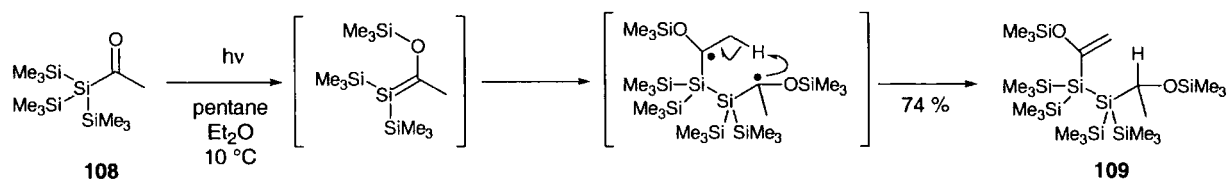

Scheme 48

Finally, it should also be noted that Oehme's mesityl silene **97** was found to undergo a [4+2] dimerisation even though this involved destruction of the aromaticity, Scheme 49.⁷⁸ This too is probably the result of an initial joining of silicon atoms followed by reaction of the resulting diradical to give **110**.

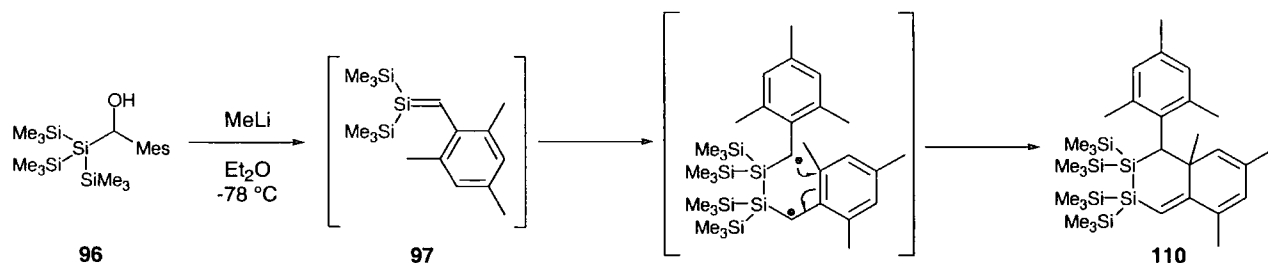

1.5.3 Cycloadditions and Ene Reactions with Alkenes and Dienes

1.5.3.1 Introduction

Unsaturated compounds have been used extensively as trapping reagents and more recent research, particularly by the groups of Auner, Wiberg and Brook, has screened the reactivity of a variety of substrates. The conventional behaviour of silenes in the presence of alkenes and dienes is therefore well established and several reviews exist on the subject.^{1, 4, 5} In the presence of unsaturated compounds, silenes may undergo one of three reactions; [2+2] addition, ene reaction or Diels-Alder [4+2] cycloaddition, Scheme 50.

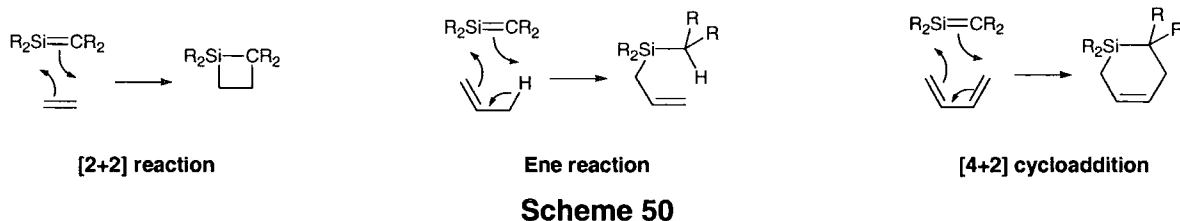

Research into these reactions can be rationalised according to the information it has provided with regard to chemoselectivity, regioselectivity and stereoselectivity and this review will be divided accordingly.

1.5.3.2 Chemoselectivity ([4+2], [2+2] or Ene)

[4+2] Cycloadditions and ene reactions of silenes involve 6π electrons and are comparable with their hydrocarbon analogues. However, [2+2] addition involves only 4π electrons and is formally disallowed by Woodward-Hoffman rules.⁸⁷ Nevertheless, [2+2] addition does occur, for example, stable silene **25** reacts with methoxyethene to give **111** and styrene reacts with silene **112** to afford adduct **113**, Scheme 51.⁸² This pathway can be explained as either involving low lying silicon d orbitals or being stepwise in character involving ionic or radical intermediates.⁸⁸

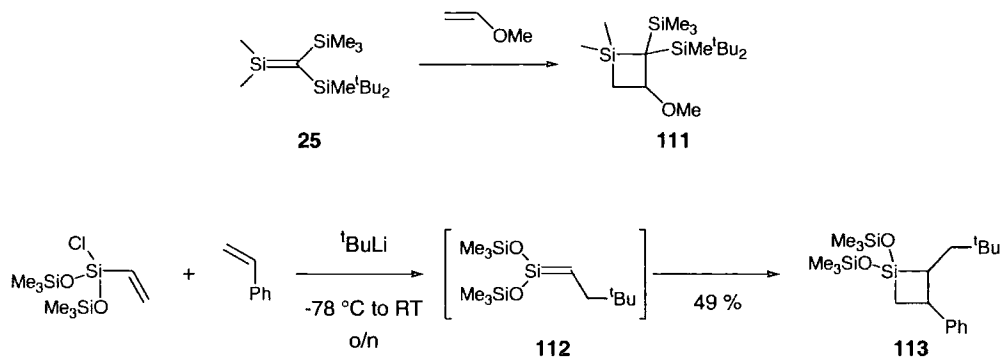

Scheme 51

In the presence of dienes such as 1,3-butadiene, cyclopentadiene and cyclohexadiene, a silene can undergo [2+2] or [4+2] cycloaddition. Ene reactions do not occur because, in 1,3-butadiene, there are no allylic hydrogen atoms available and in the cyclodienes the orbitals are not aligned correctly for such a reaction. Hence, use of these substrates reveals information about a silene's chemoselectivity for [2+2] or [4+2] additions. Thus, in trapping silenes **114** with cyclohexadiene Auner has shown that the ratio of [2+2] to [4+2] products depends heavily on the substituent on silicon, Scheme 52.^{82, 89, 90} As can be seen from Table 4, carbon-substituted silenes tend to undergo [4+2] cycloaddition. In particular, for $\text{R}=\text{Ph}$, no [2+2] adducts were detected and this is attributed to the steric bulk of the Ph groups. Conversely, silenes with electronegative π -electron donating substituents (Cl , OSiMe_3) show a propensity to react in a [2+2] mode.

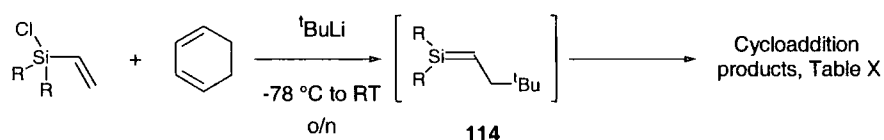

Scheme 52

R	Yield /%					Ref
	[4+2] products		[2+2] products		Dimers	
Ph	34	14	0	0	10	89
Me	14	28	15	13	18	91
OSiMe_3	15	31	23	31	0	82
Cl	16	10	46	28	0	90, 91

Table 4

These observations are explained as the result of two effects; firstly, the reaction involves the HOMO of the silene and the LUMO of the diene. π -donation lowers the energy of the silene HOMO which is unfavourable for [4+2] cycloaddition. Secondly, the increased polarity of

these silenes renders them more electrophilic and so facilitates a more ionic stepwise mechanism which is inherent in the [2+2] reaction, Scheme 53. This also accounts for the regioselectivity of the [2+2] reaction as after the nucleophilic attack by the diene on silicon, a positive charge will be left in a stable allylic position in the diene.⁹¹

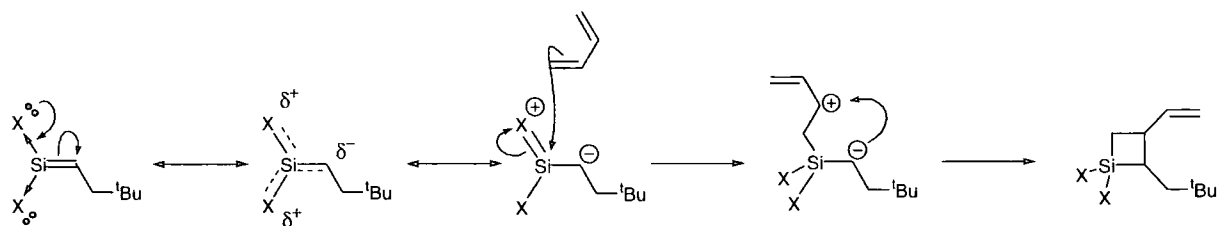

Scheme 53

Consistent with these observations, butadiene combines with alkyl substituted silene **25** in a [4+2] fashion only to afford **115** whereas the highly polarised **116** undergoes exclusive [2+2] addition to furnish **117**, Scheme 54.^{28, 29, 35, 92} In contrast to these high selectivities, Brook's reversed polarity silenes **65** gave mixtures of products **118** and **119** with the ratio varying greatly with the R group on carbon.⁸⁸ Unlike Auner's polar silenes, attempted radical trapping and solvent variation experiments revealed the [2+2] addition of reversed polarity silenes **65** to be concerted with no disposition towards a radical or anionic stepwise mechanism.

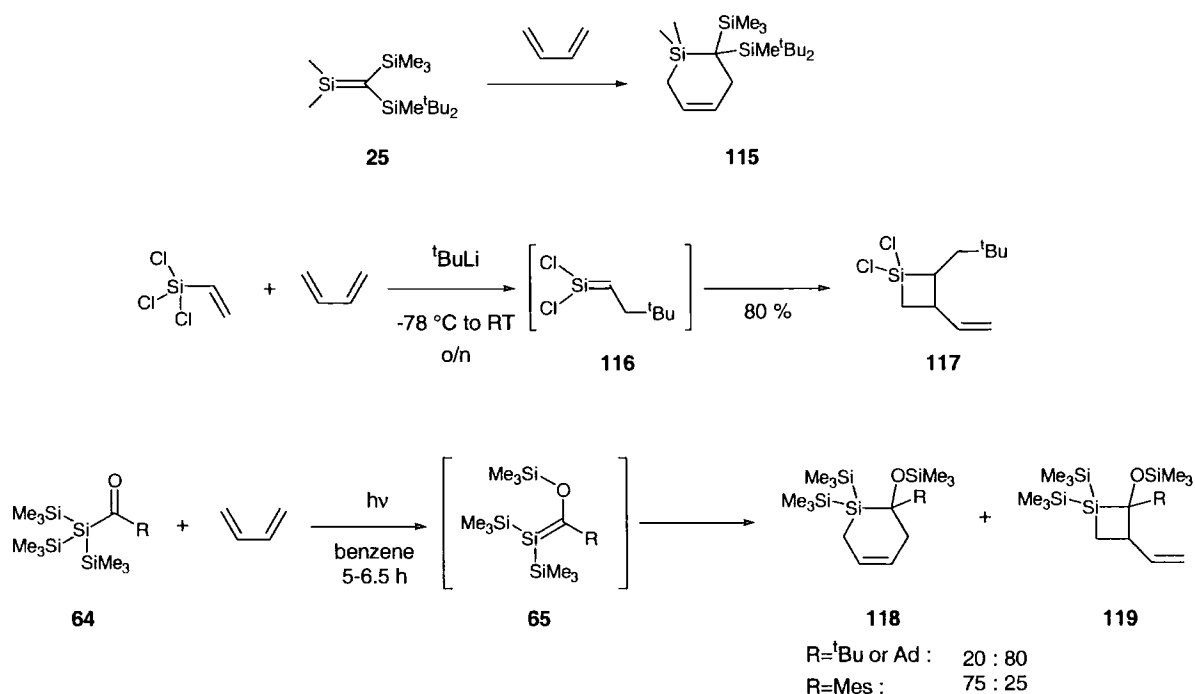

Scheme 54

While the chemoselectivity of the above reactions depended on the substituents of the silene, some dienes will only undergo one type of reaction independent of silene substitution. For example, Griffiths discovered that dimethyl-*trans*, *trans*-2,4-hexadienoate **120** reacted with thermally generated silenes **65** in a [2+2] manner only to yield **121**, Scheme 55.¹⁰ This was

highly unusual since the same silenes reacted in only a [4+2] manner with cyclopentadiene and 1,3-pentadiene. A model of the [4+2] diester product revealed the structure to be considerably sterically crowded, which may explain the preference for [2+2] addition. Moreover, the LUMO of the diene has been significantly lowered by the ester functionalities which disfavors [4+2] cycloaddition.

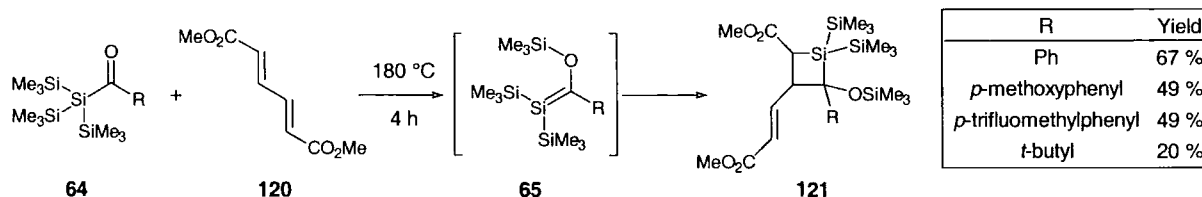

Scheme 55

In contrast, cyclopentadiene only undergoes [4+2] cycloaddition with all silenes. Thus, Jones' phenyl-methyl-substituted silene, Auner's polar dichlorosilene **114** and Brook's stable silenes **65** all gave exclusively the [4+2] cycloadducts **122** and **123**, respectively, Scheme 56.^{61, 88, 93} This is ascribed to the increased reactivity of the constrained diene and the perfect positioning of its orbitals for [4+2] reaction with a silene.

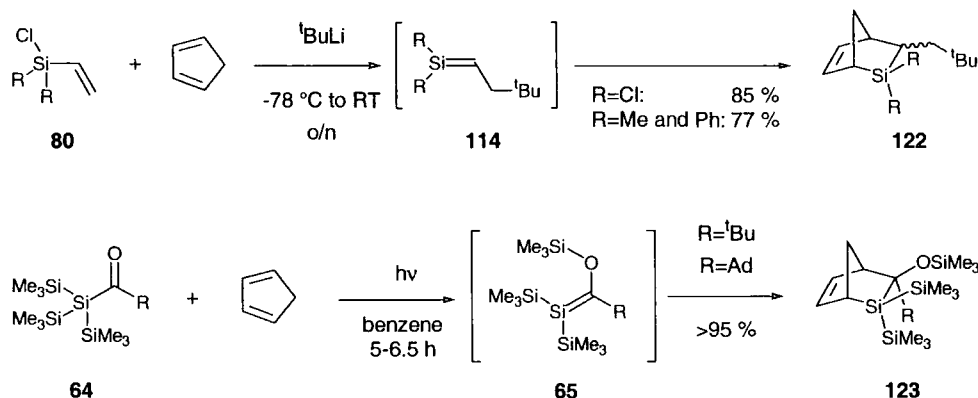

Scheme 56

As described earlier, the formation of ene products was not possible in the above reactions. When a silene is reacted with an open-chain alkene, however, the availability of allylic hydrogen atoms leads to ene reaction in preference to the [2+2] addition due to the lower energy barrier for a formally allowed process. Accordingly, stable silene **25** reacts with propene or isobutene to give allylsilanes **124**, Scheme 57.^{29, 35}

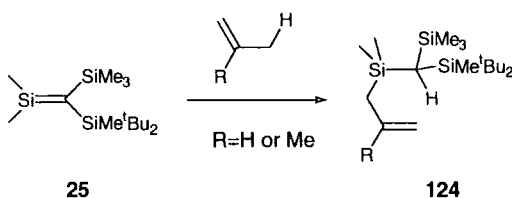

Scheme 57

2,3-Dimethylbutadiene possesses allylic hydrogen atoms and can therefore undergo any of the three reactions available. Table 5 gives the product ratios resulting from the reaction of a

variety of silenes with 2,3-dimethylbutadiene and allows several observations to be made. It should first be noted that the two conformations of 2,3-dimethylbutadiene, arising from rotation about the central bond, are very similar in energy due to similar steric constraints between the two, Scheme 58. This is in contrast to 1,3-butadiene which tends to occupy the 'trans' conformation which involves less steric clash. This makes 1,3-butadiene more likely to react in [2+2] mode than 2,3-dimethylbutadiene. This is particularly evident in the reaction of reversed polarity silenes **20**, **126** and **127** which give no [2+2] adducts with 2,3-dimethylbutadiene, but produced a mixture of [2+2] and [4+2] products with 1,3-butadiene, as described earlier, Scheme 54. In addition, ene product is formed in varying proportions in all cases except with silenes **126** and **127** which are very strongly reverse polarised. In these cases, electrostatic interactions would promote interaction of the δ^+ hydrogen of the diene with the δ^- silicon center of the silene, but this is highly unlikely due to mismatched orbital energy levels. Instead, the [4+2] reaction occurs exclusively because it incorporates the 3p silicon orbital and the 2p carbon orbital which are closer in energy. As discussed earlier, silenes **112** and **116** tend to react in a [2+2] manner rather than undergo either of the 6π reactions because they bear electronegative substituents on silicon. Similarly, silenes with silyl and carbon substitutions on silicon (**125**, **71** and **128**) do not take part in [2+2] reaction and give more [4+2] than ene products. Silene **129** reacts in an anomalous manner for an alkyl-substituted silene, giving rise to more [2+2] addition. This can be attributed to increased polarity caused by decreased p-character at silicon due to the strain in the 4-membered ring.



Scheme 58

Silene	Yield /%				Ref.
	[4+2] adduct	[2+2] adduct	Ene product	Dimers	
					
125 	66	0	14	0	62
20 	36	0	24	0	88
126 	88	0	0	0	94
127 	82	0	0	0	72, 74
71 	61	0	20	2	61
128 	20	0	5	0	89
129 	18	27	17	0	95
112 	0	53	7	14	82
116 	0	75	2	0	92

Table 5

1.5.3.3 Regioselectivity

In all of the reactions described in the preceding section the same regiochemistry was set up whereby the carbon atom of the alkene or diene with the largest orbital coefficient in the HOMO attacked silicon. This was even the case for the so called 'reverse polarity silenes' **126** and **127**. Similarly, the stable, 'reversed polarity silene' **20** reacts with 1-octene with this regioselectivity to produce allyl silane **130**, Scheme 59.⁸⁸

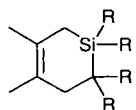
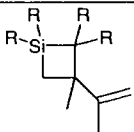
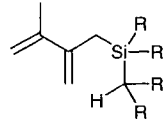
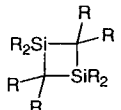
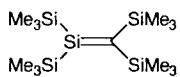
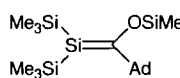
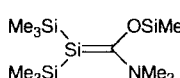
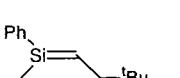
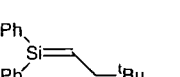
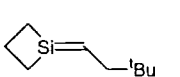
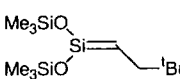
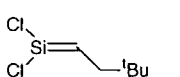
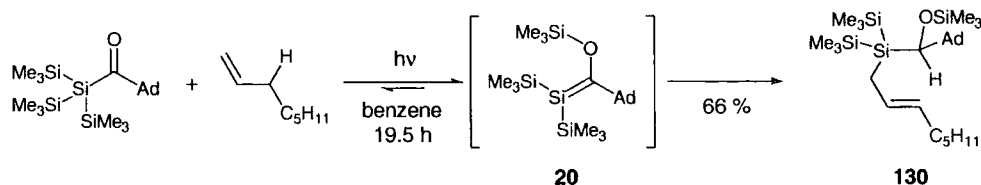

Scheme 59

This regioselectivity can be rationalised by considering frontier orbital theory. The largest coefficient of the LUMO on the silene resides on silicon and interacts with the largest coefficient of the HOMO on the alkene or diene, Figure 3.⁹⁶ Electron donating substituents on

alkenes and dienes push electron density to the end of the conjugated system, giving it the largest coefficient, so unsymmetrical unsaturated compounds react as shown in Figure 3.⁸⁷

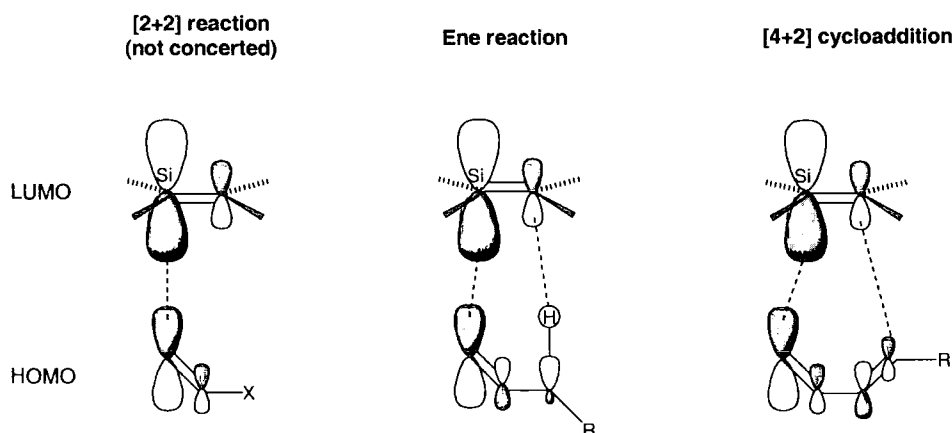
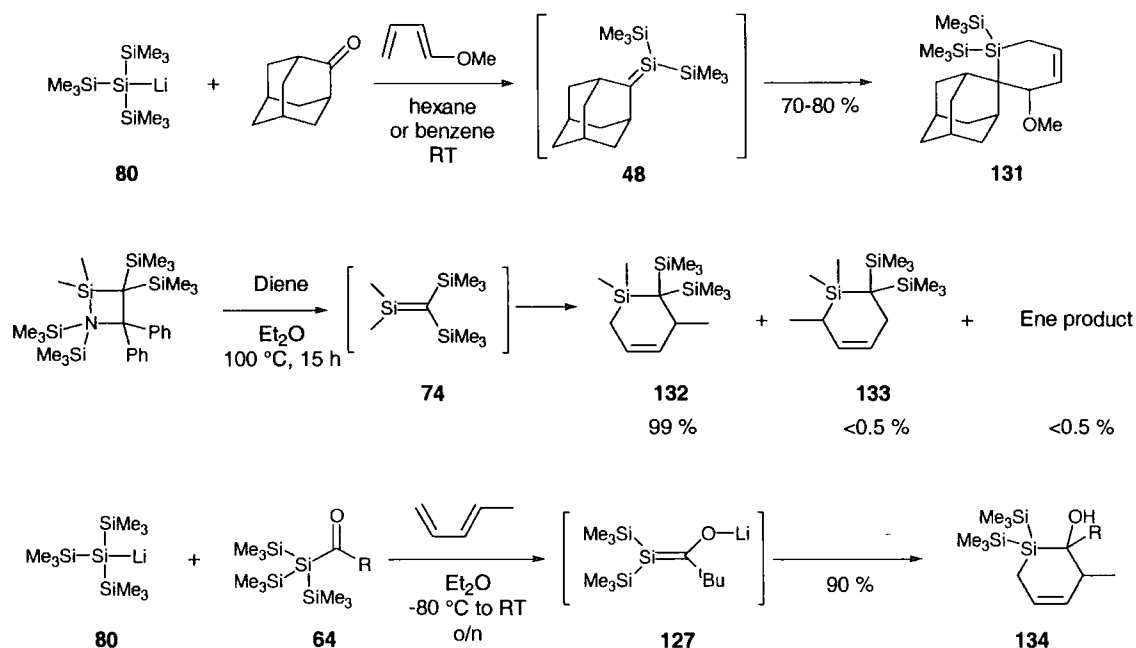

Figure 3

For example, Apeloig showed that in the presence of 1-methoxybutadiene, silene **48** was trapped to give the [4+2] adduct **131** as a single regioisomer, Scheme 60.^{39, 69} Similarly, reaction of 1,3-pentadiene with silene **74** gave exclusively the expected regioisomer **132**.⁹⁷ Furthermore, even though silene **127** has strongly reversed polarity, reaction with 1,3-pentadiene affords the same regiochemistry in the product **134** as normal silenes.⁷⁴ This can be accounted for by assuming the change in orbital coefficients brought about by polarity reversal barely competes with the natural difference in energies between the 3p orbital on silicon and the 2p orbital on carbon.



Scheme 60

Consistent with their hydrocarbon analogues, silenes react with isoprene with much less regioselectivity. Although, frontier orbital theory puts the highest coefficient on the terminal carbon next to the methyl group, the difference between the coefficients of each end is only

slight, Scheme 61. Hence, [4+2] cycloaddition with a silene should furnish regioisomer **135** as the major product, but in varying ratios with **136**. Several examples are given in Table 6 and it can be seen that this is the case with normal polarity silenes **74** and **128**.^{89, 97} However, with reversed polarity silene **20**, the ratio of regioisomers is inverted and highly reversed polarised silene **127** gives exclusively regioisomer **136**.^{74, 88} In these cases, the weak frontier orbital effects are overrun by the reversed polarity. This is in contrast with pentadiene which still gave the expected regioisomer despite the reversal of polarity.

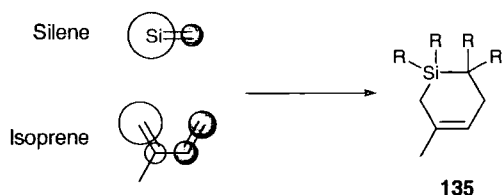

Scheme 61

Silene	Product ratio				Ref.
	[4+2] Regioisomer		Ene	[2+2]	
	135	136			
74 	66	8	26	0	97
128 	36	29	22	13	89
20 	22	67	11	0	88
127 	0	100	0	0	74

Table 6

1.5.3.4 Stereoselectivity

Stereochemical analysis of the cycloadduct products from the reaction of silenes with substituted, non-symmetrical dienes divulges facts about the stereoselectivity of the reaction. The product stereochemistry depends on both the geometry of the silene and whether it undergoes *endo* or *exo* addition to the diene. For example, Jones generated silene **71** in the presence of cyclopentadiene to obtain a mixture of all possible diastereoisomers **137-140**, Scheme 62.⁶¹ Comparison of this reaction with a similar trapping experiment with 2,3-dimethylbutadiene revealed the *E* : *Z* ratio of silene **71** to be 7 : 3.

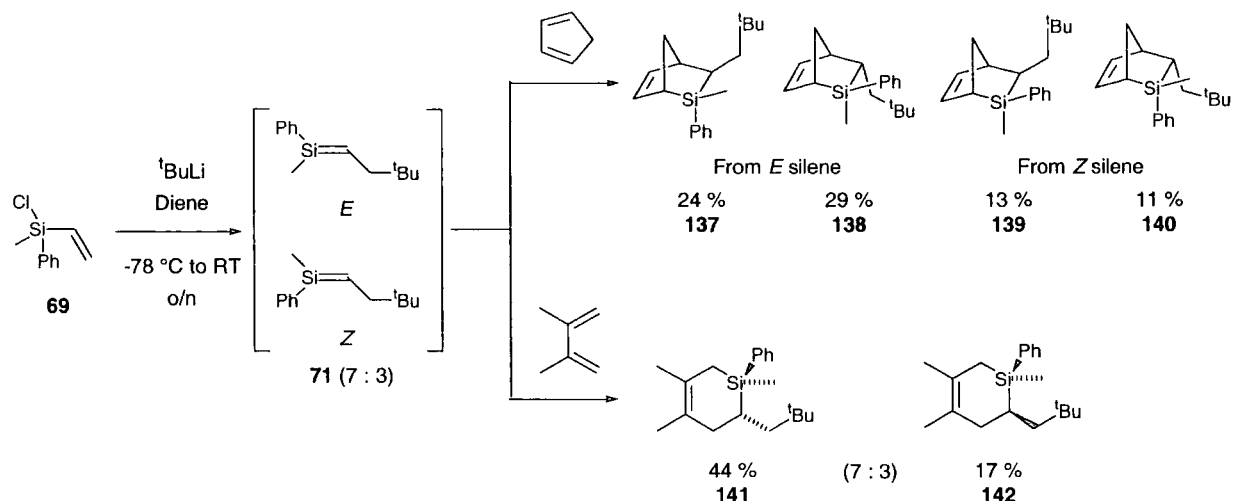

Scheme 62

In contrast, dichloro silene **116** does not possess *E* or *Z* stereochemistry, so the ratio of [4+2] cyclohexadiene cycloadducts **143** : **144** depends only on the stereoselectivity induced by the neopentyl group, Scheme 63. As can be seen, unlike other dienes, the allylic hydrogen atoms of cyclohexadiene cause steric hindrance in *exo* transition states, so silene **116** shows a slight preference to react in an *endo* fashion.^{90,91}

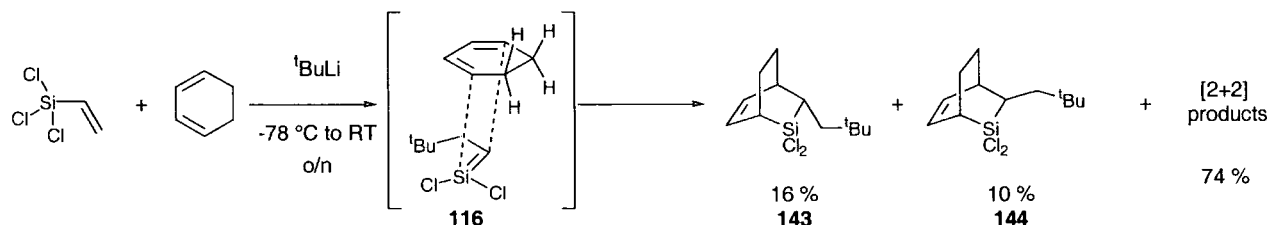

Scheme 63

Work within our group has concentrated in detail on the stereoselectivity of [4+2] silene cycloadditions. It was found that silene **146** gave moderate diastereoselectivity on reaction with several dienes, Scheme 64.⁹⁸ In all cases, the phenyl group in the major product was *endo*, a result which could be ascribed to secondary orbital interactions between the diene and the phenyl group, Figure 4.

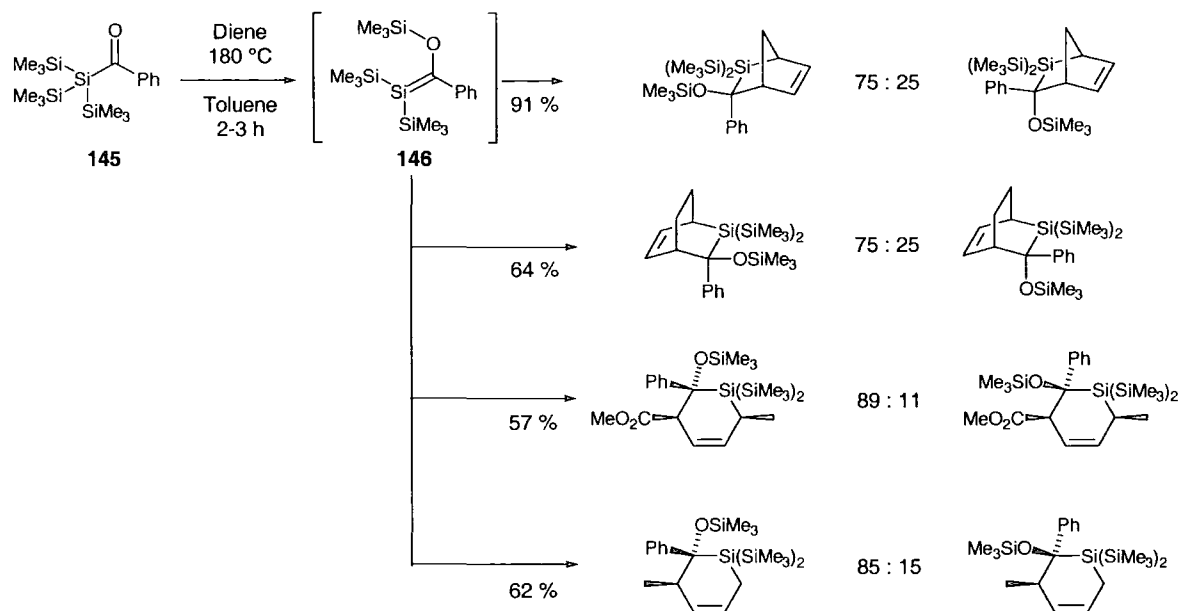

Scheme 64

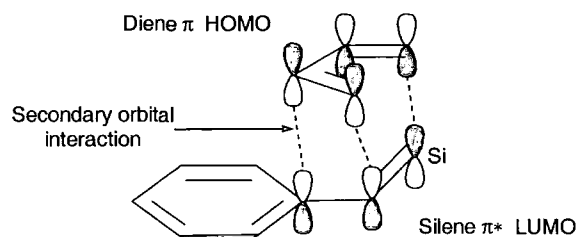

Figure 4

Substitution of the phenyl group in the above reaction has a mild effect on the diastereoselectivity, Table 7.¹⁰ Electron donating groups reduce the proportion of *endo* product (entries 2 and 4) and an electron withdrawing group increases it (entry 3). This can be ascribed to reduction in size of the π^* LUMO of the aryl group by electron donating groups which leads to reduction in secondary orbital interactions. The opposite effect is responsible for the higher diastereoselectivity of silenes with electron withdrawing groups on the aryl substituent.. On the other hand, exchange of the aromatic for a *t*-butyl group still gives predominantly the *endo* diastereoisomer with cyclopentadiene (entry 6) and this can be attributed to a steric effect between the allylic protons of cyclopentadiene and the *t*-butyl group.



Entry	R	Diene			
					
		Yield	Endo : exo	Yield	Endo : exo
1	Ph	64 %	66 : 34	91 %	75 : 25
2	<i>p</i> -MeOC ₆ H ₄	80 %	60 : 40	68 %	71 : 29
3	<i>p</i> -F ₃ CC ₆ H ₄	46 %	80 : 20	85 %	80 : 20
4	<i>o</i> , <i>p</i> -(MeO) ₂ C ₆ H ₄	80 %	50 : 50	-	-
5	Me	20 %	66 : 34	-	-
6	<i>t</i> -Bu	-	-	70 %	86 : 14

Table 7

1.5.3.5 Summary

Silenes react with alkenes and dienes readily and in high yields. Of the three possible reaction pathways, [2+2] is favoured by silenes with electronegative π -donating substituents, but also depends heavily on the diene in question. Alkenes will undergo an ene reaction in preference to [2+2] addition if allylic hydrogen atoms are available. The ene reaction of dienes with available allylic hydrogen atoms is in competition with the [4+2] cycloaddition and the ratio is determined by the silene and diene involved with steric hindrance and polarity playing a major role. Dienes substituted in the 1-position show complete regioselectivity, even with reversed polarity silenes, but isoprene gives mixtures of regioisomers. Stereoselectivity is the result of 3 effects. Firstly, the geometry of the silene involved, secondly steric hindrance and thirdly, secondary orbital interactions. This section has provided a wealth of information on the treatment of silenes with dienes and should allow rationalisation of the results arising from the project.

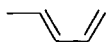
1.5.4 Cycloadditions and Ene Reactions with Carbonyl Compounds and Imines

The reactions of silenes with aldehydes, ketones and imines are very similar to those with alkenes and dienes. For example, Brook studied the reaction of several silenes **65** with a variety of non-enolisable ketones and found them all to undergo [2+2] addition to give siloxetanes **147**, Scheme 65.⁹⁹

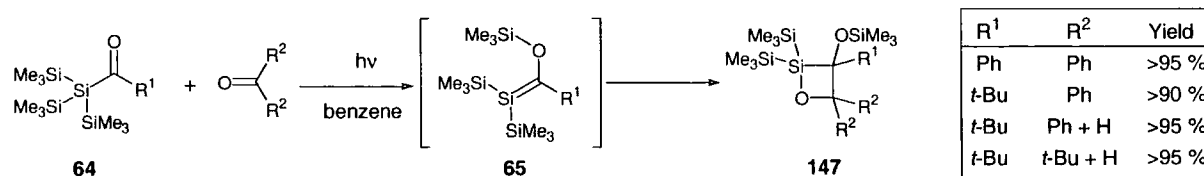

Scheme 65

Brook has shown a similar [2+2] reaction to occur when mesityl silene **149** is generated in the presence of imine **148** to give silazetidene **150**, Scheme 66.¹⁰⁰

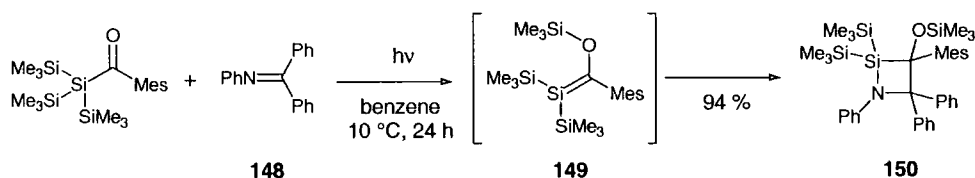

Scheme 66

In contrast, use of enolisable carbonyl compounds preferentially yields silyl enol ethers such as **151** and **152**, Scheme 67.^{35, 101} This is a result of passage through a more favourable 6-membered transition state and involvement of 6π electrons rather than 4π electrons, which is formally disallowed by Woodward-Hoffman rules.

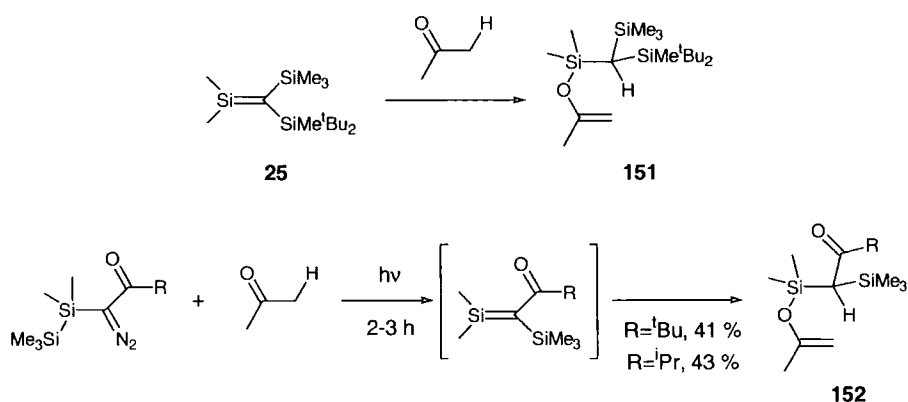

Scheme 67

Brook has studied the reactions of α,β -unsaturated aldehydes and ketones with silenes such as **18** and shown them to undergo the predictable [4+2] cycloaddition in a similar manner to dienes to produce sila-oxa-cyclohexenes **153** and **154**, Scheme 68.¹⁰² The regiochemistry of these reactions is somewhat unexpected as previous reactions with carbonyl compounds have had regioselectivity in accordance with the polarity of silenes. In this case, however, the silene **18** could be considered to have silyl silenol ether character and thus attacks the α,β -unsaturated carbonyl compounds in Michael fashion. However, simply introducing a methyl group in the β -position of the enal introduces sufficient steric hindrance to cause exclusive production of adduct **154**.

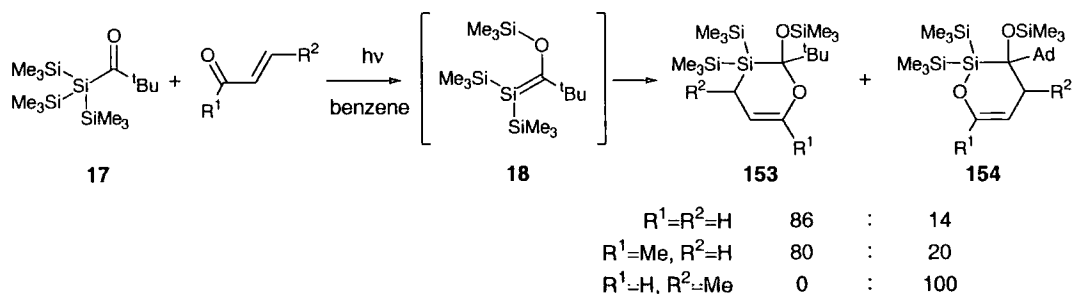

Scheme 68

In summary, aldehydes, ketones and imines tend to undergo 6π electron reactions such as 'ene' type additions or [4+2] cycloadditions if the substrate is unsaturated. However in the absence of enolisable protons or unsaturation, [2+2] additions occur.

1.5.5 Reactions with Nucleophiles

Many experiments investigating the generation of silenes have used nucleophilic trapping as evidence for the existence of the transient silene. Water and alcohols have often been employed as nucleophiles. For example, photolysis of vinylsilanes **155** in the presence of methanol gave the adduct **157** resulting from methanolic attack of silene **156**, Scheme 69.⁵³ The rate constant of such reactions are close to the diffusion limit and the regioselectivity corresponds to nucleophilic attack at silicon followed by protonation of the resulting carbanion.¹⁰³ This selectivity is always seen for silenes with normal polarity and is a result of the polarisation of the silene in order to be δ^+ at silicon. The largest coefficient of the silene LUMO is therefore on silicon.¹⁰⁴ Another example is Wiberg's treatment of stable silene **25** with water, methanol or acetic acid to give the corresponding products **158**.^{35, 105}

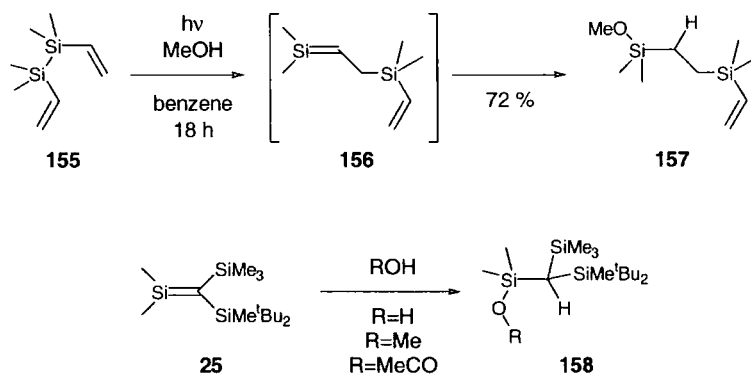

Oxygen nucleophiles have such high reactivity with silenes that re-addition of trimethylsilanolate anions can be a problem in the modified Peterson olefination. For example, in the absence of trapping agents, the highly hindered silene **159** gives more product **160**, arising from this re-addition, than silene dimer **161**, Scheme 70.⁷⁹

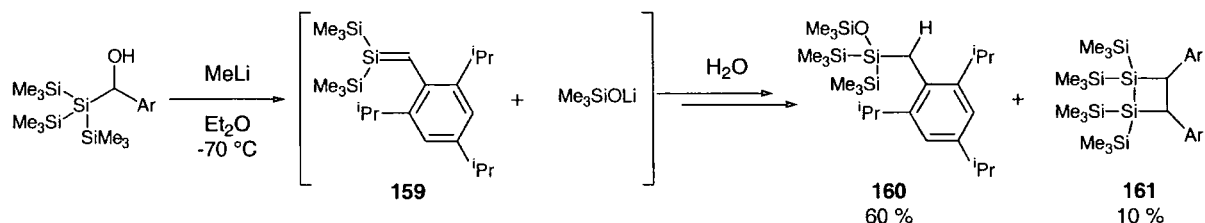

Organometallic reagents also react rapidly with silenes and several examples of this were given in Section 1.4.6.3. However, an interesting result was obtained during Brook's research into the reaction of stable silenes with Grignard reagents.¹⁰⁶ In this, silene **162** was generated

in the presence of a Grignard reagent which attacked the silicon centre to create the magnesium bromide **163**, Scheme 71. An anti-Brook rearrangement then gave oxanion **164** which underwent the 'Peterson-type olefination' to generate a second silene **165**. The formation of this silene intermediate explained the mixture of products **166** and **167** formed by addition of more Grignard across the Si=C double bond, or by re-addition of the eliminated trimethylsilanomagnesium bromide.

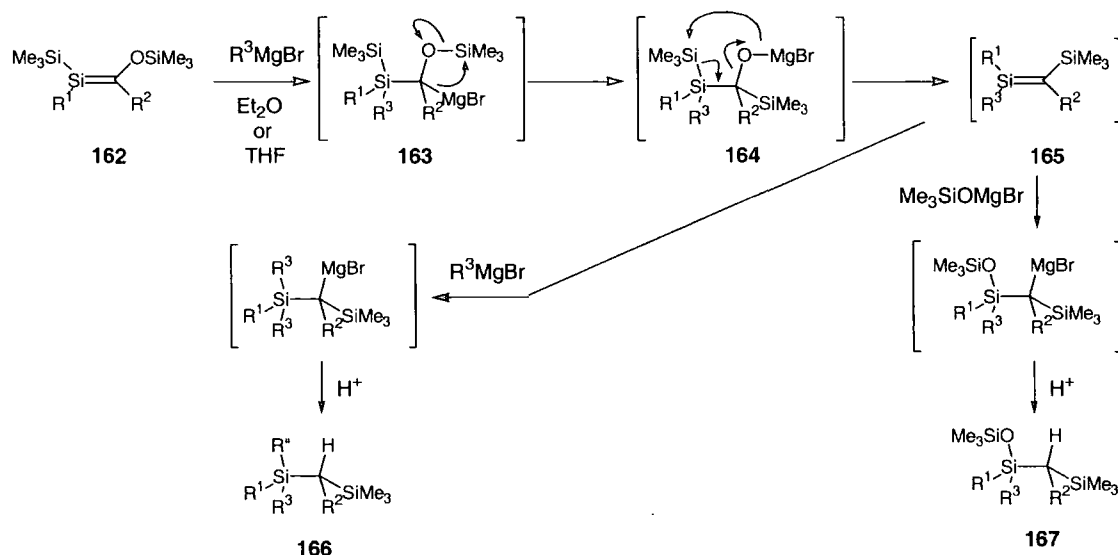

Scheme 71

1.6 Project Strategy

The general aim of this project is to address the fact that silenes have never been used in organic synthesis. The above review has shown that of all the reactions of silenes, the Diels-Alder [4+2] cycloaddition that takes place when a silene reacts with a diene has the highest potential for synthetic use. It is a powerful method of generating a molecule of great complexity in one simple step, Scheme 72. The resulting 6-membered silacycles contain multiple functionalities which facilitate a myriad of synthetic manipulations of the products. These attributes make diene functionalisation the ideal candidate for the employment of silenes in organic synthesis.

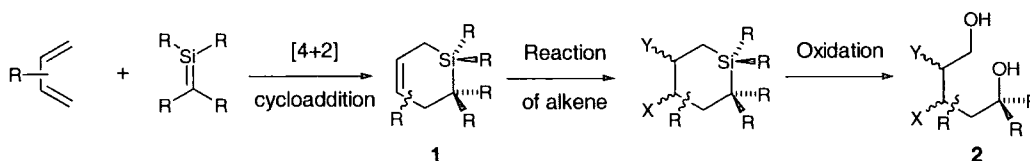

Scheme 72

Previous work in the group by Griffiths investigated the use of photolysis and thermolysis reactions for silene generation.¹⁰ As discussed in Section 1.5.3.4 (page 36), thermolysis of

benzoylpolysilane **145** in the presence of dienes gave rise to [4+2] cycloadducts in good yields and moderate diastereoselectivity, Scheme 73.^{10, 98}

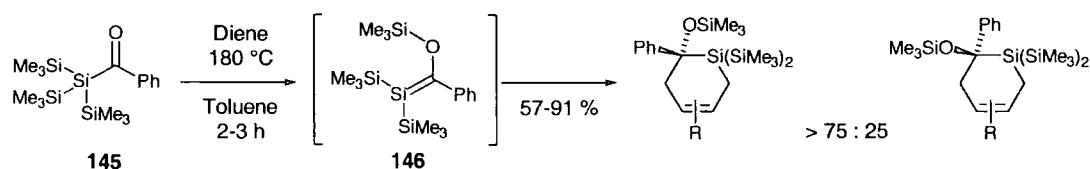

Scheme 73

However, the resulting silacycles could not be effectively elaborated to afford synthetic building blocks. For instance, attempted Tamao oxidation of saturated silacycle **168** or treatment with AlCl_3 or MeLi either gave no reaction or caused decomposition, Scheme 74.

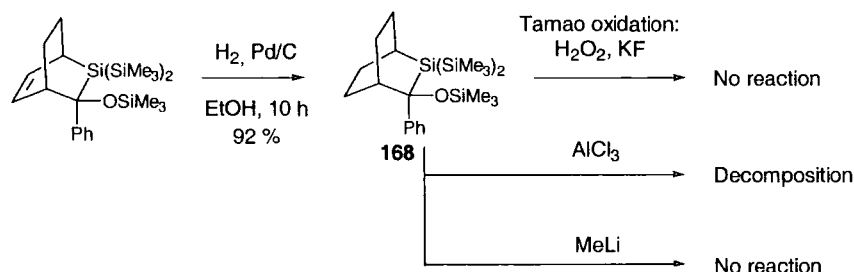

Scheme 74

It was therefore necessary to incorporate a functional group on silicon which would facilitate Fleming-Tamao oxidation at a later stage. Hence, photolysis studies by Griffiths involved the adaptation of Brook's technology to include a phenyl group on the silicon atom. Thus, acylphenyltrisilanes **169** were synthesised, photolysis of which afforded dimers **171** through the intermediacy of silenes **170**, Scheme 75. Unfortunately, the technique was only successful where $\text{R}=\text{tBu}$. The failure in other cases was ascribed to silene or dimer decomposition under the UV radiation.

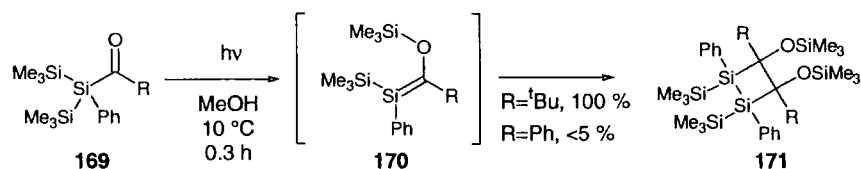

Scheme 75

These dimers, and similar analogues from the thermolysis research, were isolated with a view to their application as silene precursors. This was done by exploiting the fact that they are in equilibrium with the corresponding silene under mild conditions, as described in Section 1.3.1 (page 7).²³ Thus, stirring dimer **172** in the presence of dienes yielded the corresponding cycloadducts in good yield although with no diastereoselectivity, Scheme 76.¹⁰ Unfortunately, hydrogenated silacycle **173** was found to decompose under standard Fleming 'one-pot' reaction conditions leaving no evidence of oxidation products. This was attributed to complications arising with the OSiMe_3 group on the carbon atom adjacent to the disilyl group.

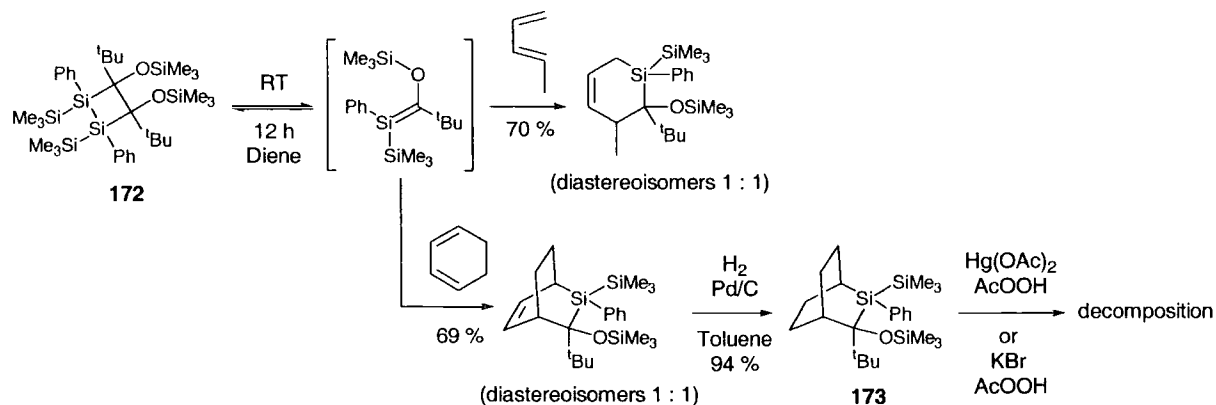

The lack of success with the above Brook silenes and their corresponding cycloadducts led to consideration of a more versatile modified Peterson olefination strategy to generate silenes **177**. On reaction with dienes these should give silacycles **178** which contain no complicating OSiMe₃ groups, Scheme 75. Use of this methodology would allow a phenyl group to be installed on the silicon atom which, after reaction of the double bond, could be converted into fluoride using methodology developed by Fleming. The resulting fluorosilanes **180** should be readily oxidised to diols **181** using the Tamao oxidation. The precursor for such a modified Peterson reaction would be the hydroxyalkylpolysilane **176** which must be synthesised from phenylbis(trimethylsilyl)silylmagnesium bromide **175**. This silyl-Grignard reagent can be generated from phenylpolysilane **174**.^{68, 76} Scheme 77 therefore summarises the methodology which was to be investigated by its application to a range of dienes, silene R groups, and alkene functionalisations.

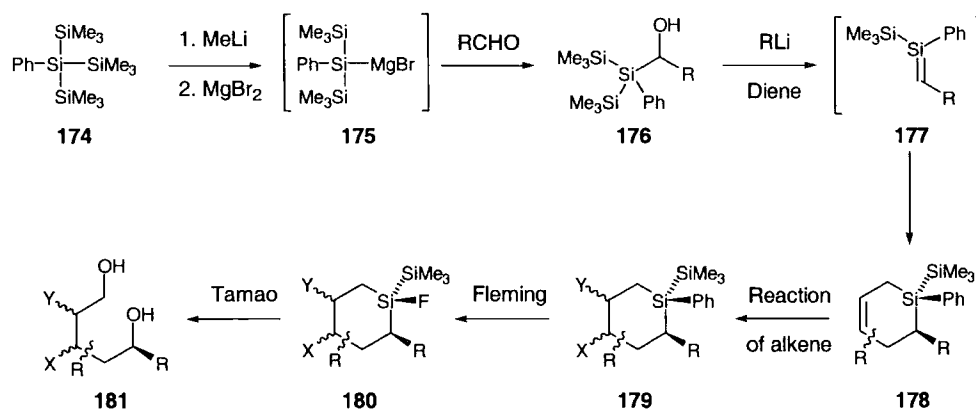

Preliminary investigations were carried out by Griffiths. Thus, hydroxyisobutyrylphenylsilane **182** was synthesised from phenyltris(trimethylsilyl)silane **174**, Scheme 78.^{68, 76} Treatment of **182** with MeLi in the presence of 1,3-pentadiene yielded the silacycle **183** as what appeared to be a single diastereoisomer by NMR spectroscopy. Hydrogenation followed by electrophilic displacement of the phenyl group according to

Fleming succeeded in producing fluorosilane **185**, Tamao oxidation of which yielded the diol **186**.

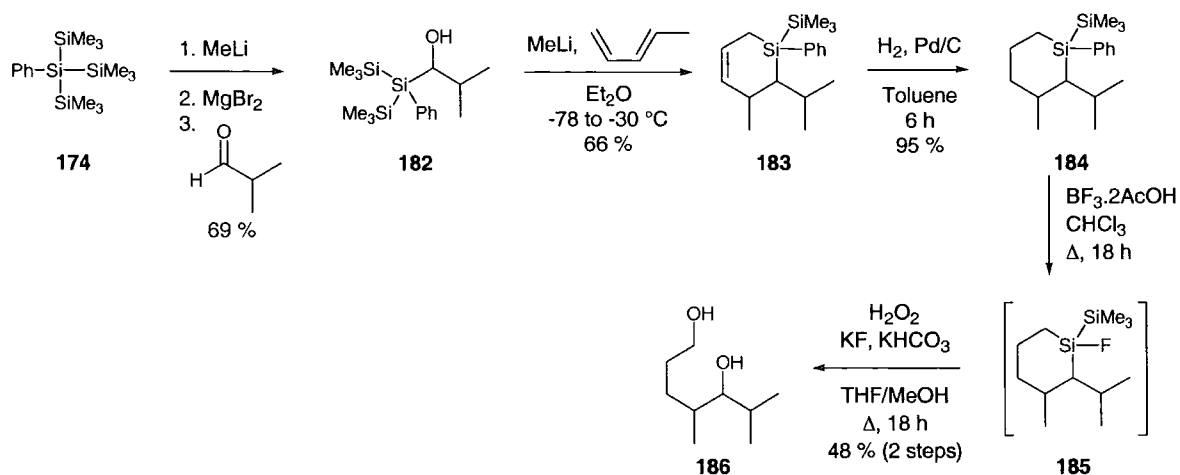

Scheme 78

These preliminary studies by Griffiths established the validity of this sequence. However a number of issues remained to be investigated:

1. Silene generation and diene trapping to give **183** in 66 % yield was not reproducible.
2. The stereochemistry of the silacycle **183** could not be assigned.
3. The application of the sequence to a variety of dienes and hydroxyalkylphenylsilanes.
4. Further possible silacycle elaborations.

Research involving the optimisation of the synthesis, mechanism elucidations and the screening of various dienes and silenes is now described in this thesis. The report begins with the synthesis of the starting material, phenyltris(trimethylsilyl)silane **174**.

2 Aryltris(trimethylsilyl)silanes

2.1 Introduction

As described in Section 1.6 (page 42) of the previous chapter, the presence of a phenyl group is a prerequisite to allow functionalisation of a silene cycloadduct *via* Fleming-Tamao type oxidation. Furthermore, it is speculated that at least two TMS groups are required for efficient conversion to the silene. This hypothesis is based on work on the photolysis of acylsilanes which include a similar TMS migration as the modified Peterson reaction. For example, Brook showed that acylpolysilanes were far superior to acyldisilanes in forming silenes by photolysis (see Section 1.4.4, page 13) and studies by Griffiths showed that the generation of silene **188**, with two Ph groups on the silicon atom, by thermolysis of acylsilane **187** was not possible, Scheme 77.^{10, 23} These criteria necessitate the incorporation of one aromatic and two TMS groups in the silene precursor whose synthesis requires aryltris(trimethylsilyl)silane as starting material. Such silanes have also found previous widespread use in assorted structural, spectroscopic and photochemical studies so a novel synthesis would find widespread application.¹⁰⁷⁻¹¹⁵

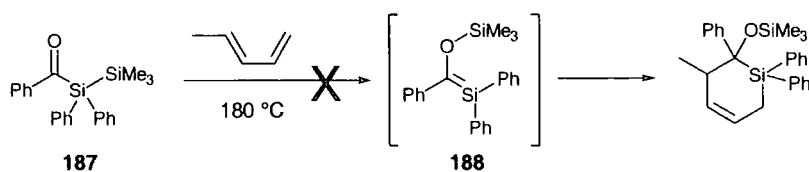

Scheme 77

In previous studies in the group, Griffiths prepared phenyltris(trimethylsilyl)silane **174** from tetrakis(trimethylsilyl)silane **189** according to the synthesis given by Brook, Scheme 78.⁵⁷ The starting material **189** can be purchased or, more affordably, prepared by coupling silicon(IV)chloride and TMSCl with lithium metal according to a procedure by Gilman and Smith.¹¹⁶ Treatment of **189** with MeLi causes abstraction of a TMS group to leave tris(trimethylsilyl)silyllithium which is protonated on work-up to afford the well known radical initiator tris(trimethylsilyl)silane **190**.¹¹⁷⁻¹¹⁹ Silane **190** undergoes a radical mediated hydrogen-bromine exchange in the presence of 1-bromobutane to furnish silyl bromide **191** and butane gas.^{120, 121} Griffiths found it unnecessary to isolate this bromide compound so the Grignard reagent was added to the reaction mixture in a 'one-pot' procedure to afford phenylpolysilane **174** in an overall yield of 73 %.

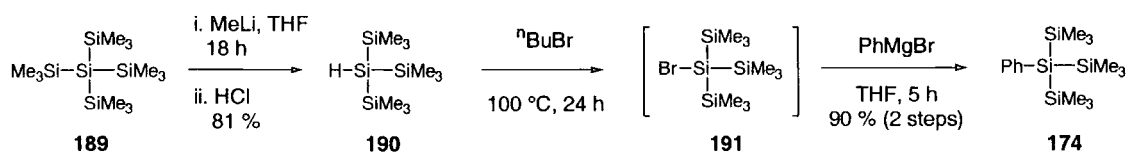

Scheme 78

2.2 Investigation of the Brook Synthesis

Tetrakis(trimethylsilyl)silane **189** was routinely synthesised, on up to a 120 g scale, using the aforementioned lithium coupling, Scheme 79.¹¹⁶ The form of the lithium was found to be of utmost importance as lithium rods gave between 13 and 48 % yield whereas lithium ribbon consistently provided the product in 50-60 % yield. This is attributed to the increased surface area of the metal. Furthermore, the lower yields in each range are ascribed to the age of the lithium metal employed which undergoes some oxidation over time.

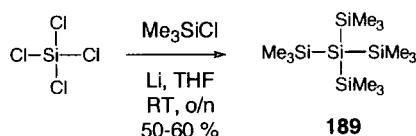

Scheme 79

Addition of MeLi to this material afforded a deeply coloured solution of silyllithium **80**, Scheme 80. Acid work up of the reaction mixture produced tris(trimethylsilyl)silane **190** in high yield although purification proved hazardous because **190** has been shown to be spontaneously combustible in air. Distillation to a high degree of purity increases the risk of explosion and on one occasion, *after distillation, air was allowed into the flask and a small explosion occurred*. In subsequent reactions, to reduce this risk, the purity of the crude silane **190** was analyzed by GC and ¹H NMR (the product showing a small peak at $\delta_{\text{H}} = 2.14$ ppm corresponding to the silicon bound proton and a large peak at $\delta_{\text{H}} = 0.193$ ppm for the TMS protons) and the option of using the material crude in the next reaction considered. When distillation was required, the purified silane **190** was used immediately in the subsequent step. Unfortunately, the presence of impurities did lower the yields of the next reaction.

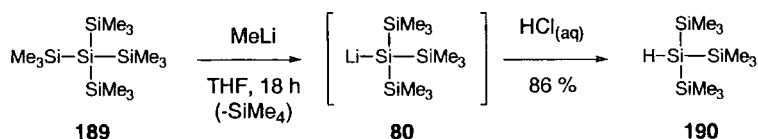

Scheme 80

Radical-mediated hydrogen-bromine exchange with 1-bromobutane was found to be a reliable reaction, easily monitored by GC, Scheme 81. Proof that the GC peak was indeed that of bromide **191** was obtained in the form of a GCMS trace showing a doublet of

isotopic bromine molecular ions at $m/z = 326$ and 328 . At first, it was thought that excess 1-bromobutane should be removed by evaporation prior to addition of phenylmagnesium bromide but this was later found to be unnecessary. Initial attempts to conduct the Grignard addition with commercial phenylmagnesium bromide were unsuccessful and it was subsequently found that the choice of solvent was essential as the use of ether gave no desired product. Thus a 1 M solution of phenylmagnesium bromide in THF was used to good effect in all subsequent reactions to give the desired silane **174**. All data on this compound agreed with that given by Griffiths but it is characterised in particular by a large peak at $\delta_{\text{H}} = 0.215\text{-}0.217$ ppm due to the TMS protons in the ^1H NMR spectrum.

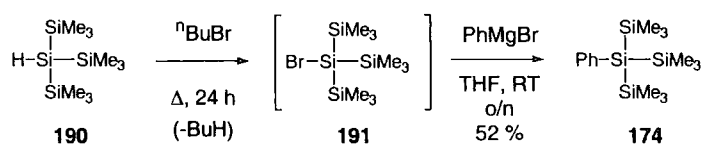

Scheme 81

Although silane **174** is a relatively simple material, the above route involves 3 separate reactions, with purifications, which renders it time-consuming. Furthermore, the highest overall yield, from silicon(IV)chloride, was only 27 %. The major disadvantage of this route, however, is the hazard associated with distillation of the spontaneously combustible tris(trimethylsilyl)silane **190**, so alternative one-step syntheses which avoid this material were investigated.

2.3 One-Step Syntheses

2.3.1 Reactive Metal Coupling Reactions

It was hypothesised that replacement of silicon(IV)chloride in the synthesis of tetrakis(trimethylsilyl)silane **189** with trichlorophenylsilane **192** would allow direct synthesis of phenyltris(trimethylsilyl)silane **174** in one step. Trichlorosilane **192** is a cheap, commercially available reagent and a search of the literature showed precedent for this reaction: Herzog and Roewer stirred a large excess of TMSCl with PhSiCl_3 **192** in the presence of excess lithium powder in THF, Scheme 82.¹¹⁵ Fractionation yielded the product **174** in 50 % yield. Similarly, Oka and Nakao obtained 51 % yield with only 3.5 equivalents of TMSCl by agitation of the mixture with ultrasound.¹¹³

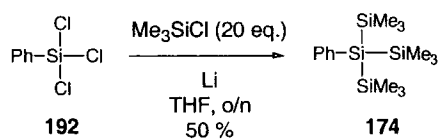

Scheme 82

An initial attempt at this reaction looked promising as a ^1H NMR spectrum of the crude material showed a large peak at δ_{H} 0.215-0.217 ppm, characteristic of **174**. Unfortunately, the product could only be isolated in 10 % yield after laborious purification. Several attempts to optimise the yield included variation of the number of equivalents of TMSCl, the mode of addition and use of a sonication vessel, but the results quoted in the literature could not be reproduced.

Interestingly, all experiments generated a major by-product which remained after distillation as a white solid. Recrystallisation from ether gave large clear hexagonal crystals. This product showed no aromatic protons by ^1H NMR, but the presence of one olefinic proton at $\delta_{\text{H}} = 5.91$ ppm and several TMS groups. MS was inconclusive due to the small size of the molecular ion peak and the compound eluded identification until X-ray crystallography revealed it to be compound **193**, Figure 5, Scheme 83. Silane **193** is the result of two Birch-type reductions of the phenyl group of the desired product **174**, followed by silylation by TMSCl. Further examination of the literature revealed prior synthesis of the material, in 10 % yield, by Puranik and Fink.¹²² In addition, they obtained phenyltris(trimethylsilyl)silane **174** in only 4 % yield in agreement with the low yields obtained in our hands.

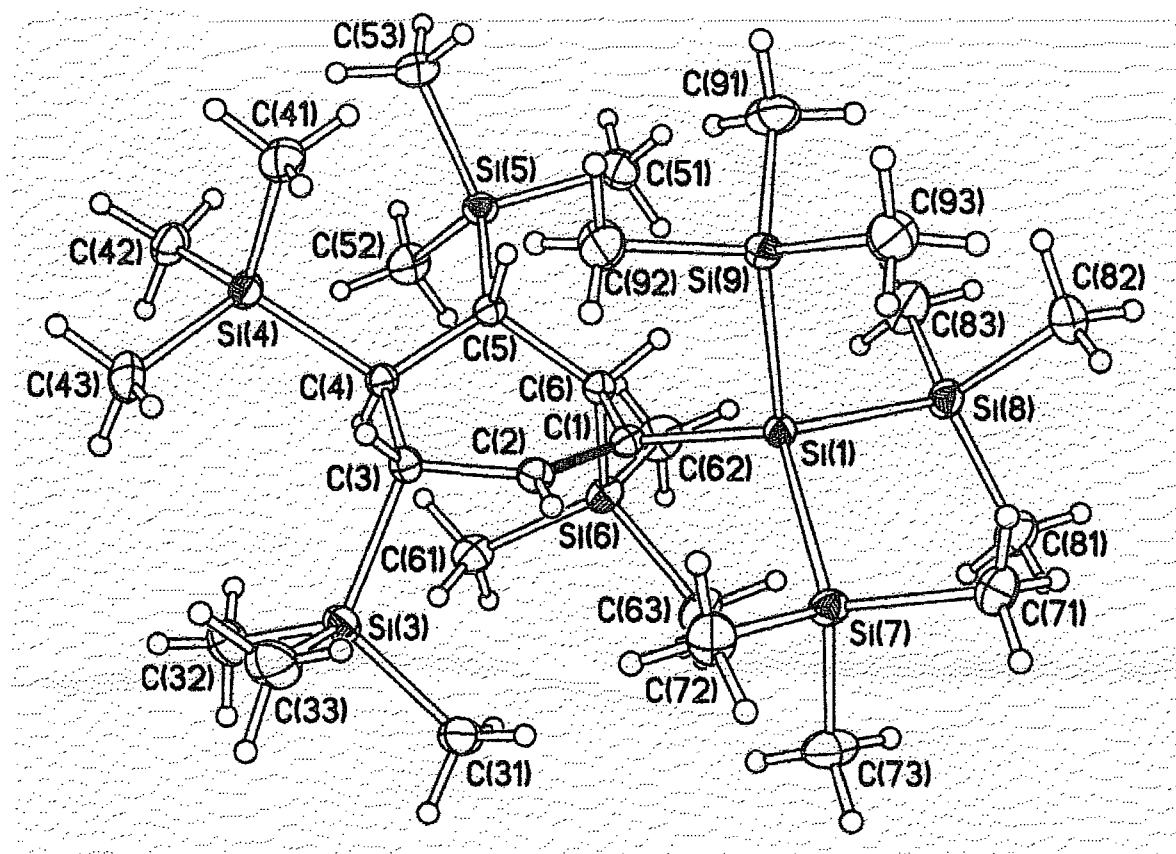
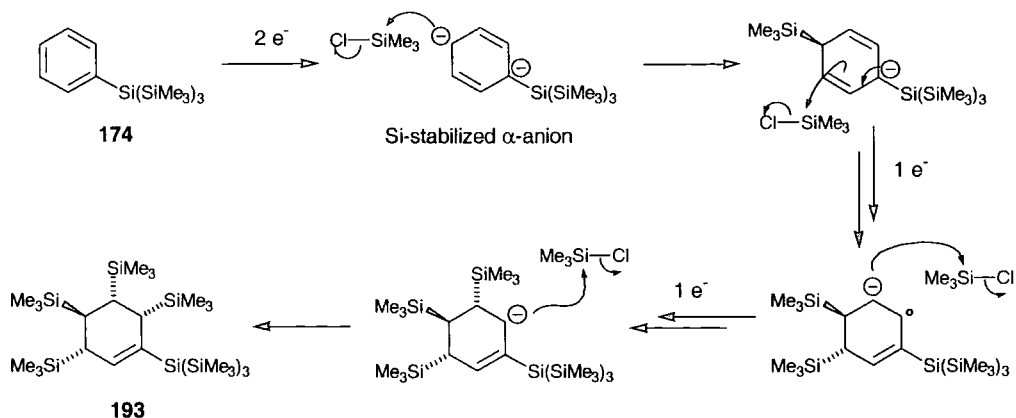
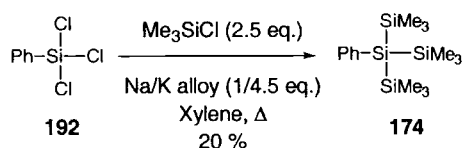

Figure 5



Scheme 83

Although the above synthesis gave very low yields, the synthesis of **174** in only one-step is still highly attractive. Further examination of the literature revealed a report by Hassler *et al.* on the formation of phenyltris(trimethylsilyl)silane **174** in a similar reaction utilising sodium/potassium alloy in xylene instead of lithium in THF, Scheme 84.¹²³ Their intention was to form hexasilyl dimers, but nevertheless, the reaction was done on a 2.3 mole scale and **174** isolated in 20 % yield by fractional distillation. Although this yield is low, it was thought that the reaction could be optimised to afford higher proportions of **174** and so the experiment was investigated.



Scheme 84

In view of the risks involved in the use of highly reactive potassium, the reaction was first tried with the slightly less hazardous sodium metal. The presence of the desired product in the crude product was established by NMR spectroscopy, however its isolation proved very difficult on account of the co-distillation of many by-products. Interestingly, however, no Birch-type reaction product **193** was seen and it is thought sodium in xylene has much less potential to reduce an aromatic ring than lithium in THF. Application of the mixture of sodium and potassium, described by Hassler, and scale up to 0.16 moles provided enough crude material to allow the product to be isolated in 13 % yield. *Unfortunately, an attempt to repeat the reaction on the same scale ended in disaster when a large explosion occurred.* This route was consequently abandoned for reasons of safety.

A final attempt to use a reactive metal in a coupling reaction employed magnesium. Griffiths had shown that diphenylbis(trimethylsilyl)silane **195** could be produced in this way from dichlorodiphenylsilane **194** in THF/HMPA (1:1) in a kind of *in situ* Grignard reagent generation, Scheme 85.¹⁰ An identical procedure was followed using phenyltrichlorosilane

192 and 3 equivalents of TMSCl , and again, silane **174** could be detected in the crude reaction mixture by NMR spectroscopy, but isolation was not possible.

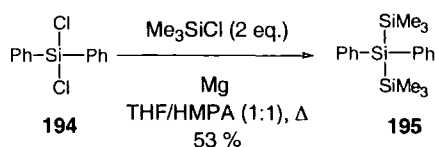

Scheme 85

2.3.2 Application of TMSLi

The major problem associated with the metal coupling reactions was the formation of dimers, polymers and other by-products with similar properties to phenyltris(trimethylsilyl)silane **174** which rendered purification almost impossible. In view of this, research turned to the generation of a pure solution of TMSLi to which PhSiCl_3 could be added, thus avoiding any self-condensation of phenylsilyllithiums. Still has shown that TMSLi **197** can be generated by the action of MeLi on hexamethyldisilane **196** in HMPA.¹²⁴ Tetramethylsilane **198** is formed during the reaction which is inert and volatile, thus leaving a solution of pure TMSLi, Scheme 86.⁹ Still used the silyllithium in reactions with ketones and enones where it underwent the expected reactions in high yields.

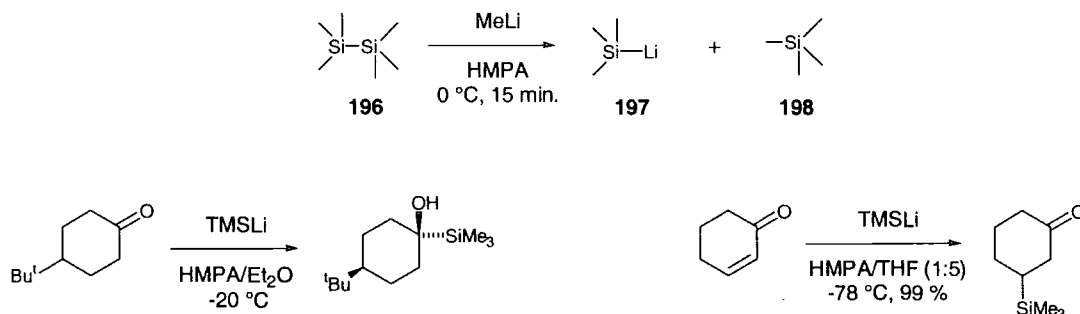

Scheme 86

Following the procedure developed by Still, TMSLi was generated in HMPA to give a deep red solution. This was diluted with THF and then PhSiCl_3 in THF was added dropwise and the reaction stirred at RT for 48 h. However, no desired product **174** was detected by crude NMR and only polymeric silyl material had been formed on aqueous work-up. Consequently, an array of reaction conditions were appraised involving variation of the temperature and the exchange of the dangerous cancer suspect agent, HMPA, with the non-carcinogenic, polar aprotic alternative, DMPU.¹²⁵ Unfortunately, no desired product was ever detected and crude NMR spectra implied formation of polymeric silyl material. It was hypothesised that the softer silyl metallic, TMSMgBr would stand a better chance of affording silane **174**. However, an attempt to form TMSMgBr , in an analogous manner to

TMSLi, by addition of MeMgBr to hexamethyldisilane followed by addition of PhSiCl₃ gave no desired product.

2.3.3 Conclusion

The synthesis of phenyltris(trimethylsilyl)silane in one step from simple starting materials was a challenging but potentially rewarding aim. Many positive results were obtained with the metal coupling reactions, but difficulties in purification always proved the drawback. The use of pure TMSLi solution proved not to be viable. Investigations therefore returned to the original synthesis by Brook with the intention of improving it by circumventing the formation of hazardous tris(trimethylsilyl)silane **190**.

2.4 Modification of the Brook Synthesis

2.4.1 Reaction of Silyllithium **80** with Bromine

The key to success in the Brook synthesis lies in the final reaction which involves addition of phenylmagnesium bromide to pure silyl bromide **191**. This is a clean reaction necessitating only simple purification. Unfortunately, the full synthesis involves several steps which are time-consuming. It was hypothesised, therefore, that the reaction could be 'telescoped' by quenching the intermediate silyllithium **80** with bromine to afford directly the silyl bromide **191**. This would omit generation of the hazardous silane **190** and the hydrogen-bromine exchange step. A survey of the literature revealed that Bochmann has provided a precedent for this reaction reporting a 'quantitative yield' of the bromide, although no purification was carried out, Scheme 87.¹²⁶

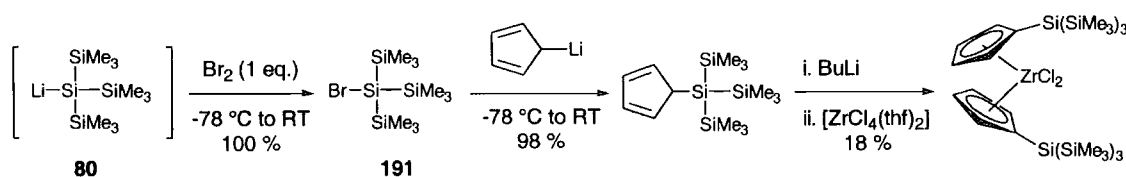

Scheme 87

Following this procedure, a solution of silyllithium **80** was added dropwise to a solution of bromine at $-78\text{ }^\circ\text{C}$. This mode of addition is necessary to prevent reaction of unreacted silyllithium **80** with silyl bromide **191**, which generates dimer **199**, identified by GCMS ($m/z=494$).¹²⁷ The reaction mixture was then warmed to RT and phenylmagnesium bromide was added. On work-up, several products could be identified in the TMS region of the NMR spectrum of the crude material and these are given in Scheme 88. Silane **190** arises from unreacted silyllithium **80**, and silanol **200** is a result of hydrolysis of unreacted silyl bromide **191**.

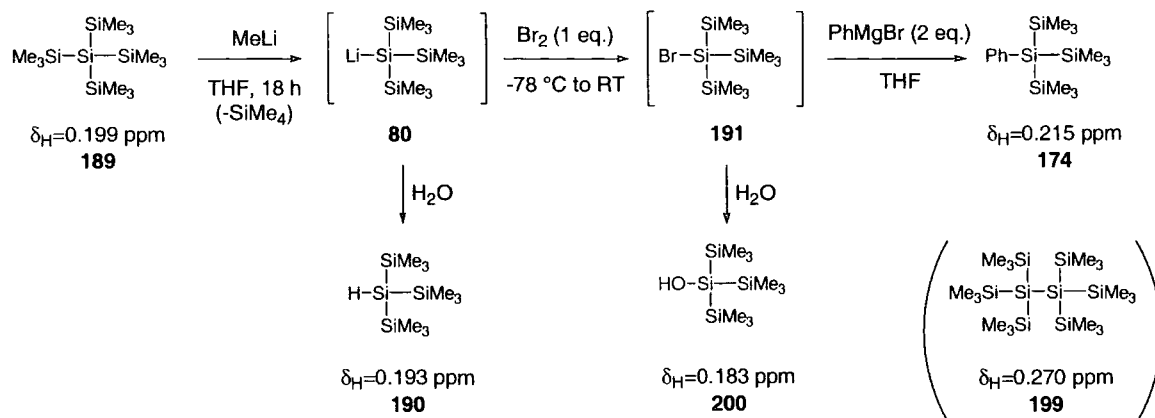

Scheme 88

Table 8 summarises the molar ratio of the above products, prior to purification, for several experiments and allows several observations to be made. The variable amount (2-18 %) of starting material (SM) **189** present is a result of the use of different batches of MeLi which vary in contaminant composition and titre.¹²⁸ However, the reformation of **189** by TMS abstraction by silyllithium **80** from any of the intermediates cannot be ruled out. The proportion of silane (SiH) **190** is generally low indicating near complete reaction with bromine. In all cases, only 1-10 % dimer **199** is formed which shows that the mode of addition employed minimises interaction between the added silyllithium **80** and the silyl bromide **191** being generated. Despite these positive observations, good yields of product **174** only occur sporadically. However, it can be noted that a low proportion of product always corresponds to a high proportion of silanol and *vice versa*. This indicates that the problem lies in the final step; the reaction of the Grignard reagent with the silyl bromide. Addition at $-78 \text{ }^\circ\text{C}$ followed by warming to RT for 1-3 h (entries 5-13) gave more consistent results than addition at RT and stirring overnight (entries 1-4), but the reaction was still not sufficiently reliable with low yields occurring in an unpredictable manner (6, 10, 12 and 13). It was hypothesised that it was necessary to quench the reaction at a certain temperature after addition of the Grignard reagent and subsequent warming. Monitoring the temperature of reaction mixtures revealed an optimum quenching temperature of $-30 \text{ }^\circ\text{C}$ (entry 9). Unfortunately, an attempt to generate **174** in high yield by holding the mixture at this temperature overnight (entry 11) gave no improvement.

Entry	Time with Br ₂ at RT	PhMgBr addition	Time after PhMgBr addition*	Molar % by NMR					Yield
				SM 189	SiH 190	SiOH 200	Dimer 199	Prod. 174	
1	4 h	RT	16 h (+ 5 h Δ)	2	4	79	3	12	-
2	0.5 h	RT	67 h	4	2	79	6	9	-
3	1 h	RT	19 h	17	0	44	2	37	25 %
4	2 h	RT	19 h	2	2	79	6	11	-
5	3 h	-78 °C	2 h	13	0	1	2	84	56 %
6	2 h	-78 °C	3 h	8	0	72	9	11	-
7	1 h	-78 °C	1 h	3	3	4	5	85	49 %
8	2 h	-78 °C	2 h	2	10	9	10	69	56 %
9	2 h	-78 °C	1.5 h	3	7	12	5	73	63 %
10	3 h	-78 °C	2 h	3	3	82	5	7	-
11	3 h	-78 °C	20 h at -30 °C	5	0	64	7	24	20 %
12	2 h	-78 °C	1.5 h	12	0	83	2	3	-
13	2.5 h	-78 °C	1.5 h	18	21	55	1	5	-

*Time after addition of phenylmagnesium bromide and removal of dry ice bath.

Table 8

In consideration of the unpredictability of the reaction, concerns were raised over the potential reaction of THF with bromine. Such a reaction is preceded and shown in Scheme 89.¹²⁹

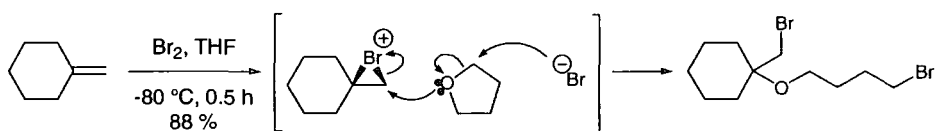

Scheme 89

A similar mechanism could take place with silyl bromide **191** to give alkoxy silane **201**, Scheme 90. If **201** was hydrolysed on work-up to afford silanol **200**, then the coincidence of low product yields with a high proportion of silanol could be explained as the result of intermediate **201** being unreactive towards phenylmagnesium bromide. Furthermore, if the mechanism is not ionic, as shown, but involves radical intermediates, or if the opening of THF is an early step, then the unreliability of the reaction could be the result of several factors. These could include the time and temperature that bromine was dissolved in THF, the time taken for the addition of silyllithium **80** and even the intensity of light on the

reaction. With this in mind, research turned to the application of alternative sources of 'Br⁺'.

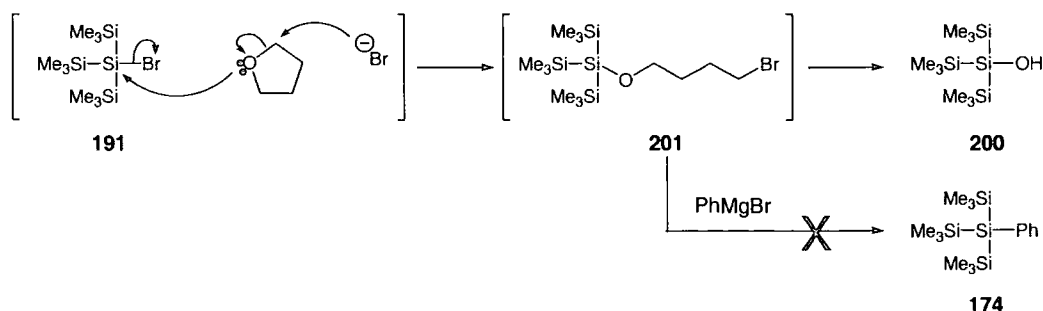

Scheme 90

One very useful discovery made during this research was that tris(trimethylsilyl)silylpotassium could be used instead of silyllithium **80**. This was synthesised according to Marschner by treatment of tetrakis(trimethylsilyl)silane **189** with KO^tBu in THF.¹³⁰ A reaction time of only 2 h coupled with easier handling of the reagent and higher reliability render the technique far superior to that using MeLi.

2.4.2 Alternative Brominating Agents

2.4.2.1 Tetrabutylammonium tribromide (ⁿBu₄NBr₃)

ⁿBu₄NBr₃ has been used as a stable, weighable brominating agent with superior handling characteristics compared to liquid bromine which is volatile, toxic and corrosive.¹³¹ Consequently, attempts to trap silylpotassium **202** with this reagent were carried out, Scheme 91. Unfortunately, no chemical advantage over the use of bromine was accrued with two similar experiments giving contrasting results, Table 9. The large proportion of dimer **199** and SM **189** present in each case is attributed to the small scale (1 g of SM) of these reactions relative to the reactions in which bromine was used (5-30 g of SM).

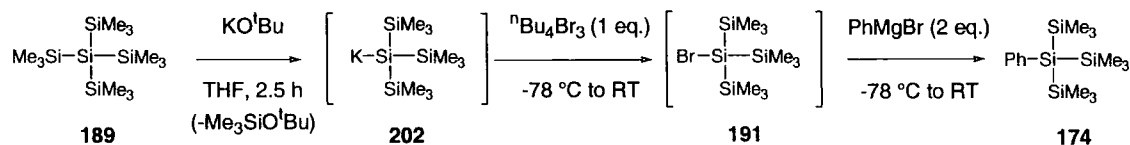

Scheme 91

Entry	Time with ⁿ Bu ₄ NBr ₃ at RT	PhMgBr addition	Time with PhMgBr at RT	Molar % by NMR					Yield
				SM 189	SiH 190	SiOH 200	Dimer 199	Prod 174	
1	21 h	-78 °C	1 h	17	0	58	18	7	-
2	2.5 h	-78 °C	16 h	11	7	15	30	37	16 %

Table 9

2.4.2.2 N-Bromosuccinimide (NBS)

NBS is also a weighable solid which provides small amounts of bromine in solution or acts as a brominating agent in its own right. Hence, silylpotassium **202** was added to NBS in the same fashion as described above. Surprisingly, GCMS showed predominant formation of tris(trimethylsilyl)silyl succinimide **203** ($m/z = 346$ (MH^+)) instead of the expected silyl bromide **191**. This is either the result of S_N2 reaction of **202** at nitrogen or formation of potassium succinimide **204** and silyl bromide **191** followed by coupling, Scheme 92. Nevertheless, addition of phenylmagnesium bromide followed by aqueous work-up and NMR spectroscopy of the crude product mixture showed a peak at $\delta_H=0.217$ ppm (38 molar % of the mixture) corresponding to the desired product **174**. A series of reaction conditions were therefore investigated in order to optimise the yield.

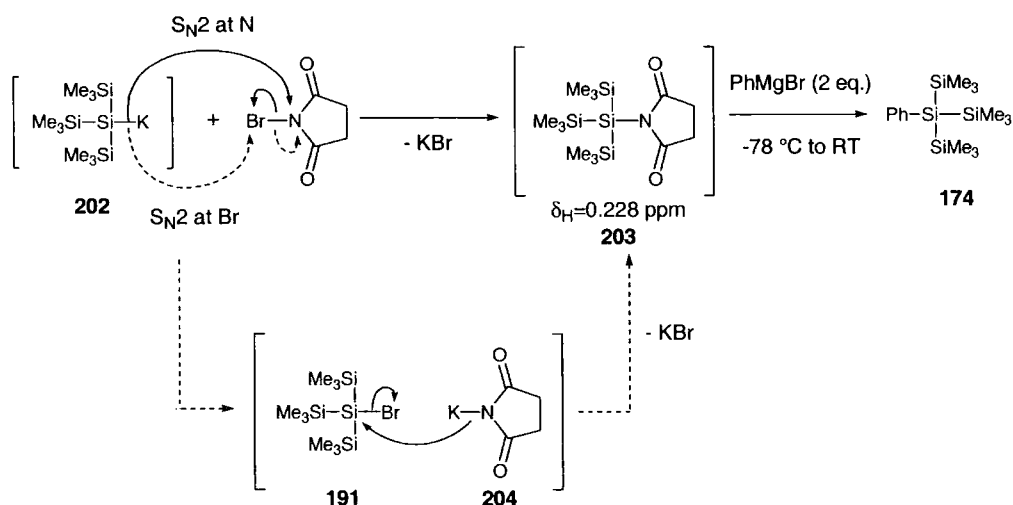

Scheme 92

Reactions were monitored at all stages by treating a small aliquot with aqueous ammonium chloride and running GC of the organic layer. Consistent with earlier reactions with bromine, silylpotassium **202** was added dropwise to a solution of NBS at -78 °C followed by warming to RT over 0.5-1 h. After reaction with PhMgBr and work-up, analysis of the crude NMR showed approximately 10 molar% dimer **199**. This must be formed by interaction of silylpotassium **202** with silyl bromide **191** and provides evidence that the latter pathway for formation of silylsuccinimide **203** is correct. Further experiments showed that higher proportions of silylsuccinimide **203** were obtained by addition of **202** to NBS at RT. Moreover, this reduced the proportion of dimer because the warmer NBS now reacted more quickly with silylpotassium **202** as it was added dropwise, thus reducing its accumulation. It should also be noted that the use of *N*-iodosuccinimide offered no advantage over NBS and *N*-chlorosuccinimide was sufficiently unreactive to leave a large proportion of silylpotassium which was detected as silane **190** on work-up.

Table 10 gives some examples of the ratio of products by GC after reaction with NBS and PhMgBr and the NMR ratio after work-up. This data allows some important observations to be made:

1. The amount of silanol **200** is small prior to addition of the Grignard reagent but increases afterwards. This is believed to be the result of formation of intermediates which are hydrolysed to silanol after treatment with aqueous NH_4Cl solution.
2. More than 2 equivalents of PhMgBr are required to generate high proportions of product. This is particularly evident in entry 2 where the reaction had become static after addition of 2 equivalents, but the proportion of product **174** could be made to increase by addition of an extra 1.5 equivalents of PhMgBr.
3. This increase in product was not to the detriment of silyl succinimide **203**, but rather of silanol **200**. In order to investigate this, pure silyl succinimide **203** was isolated in 13 % yield (entry 3). This low yield is attributed to the use of 1.5 equivalents of NBS which, rather than maximising the yield of **203**, degraded it. In addition, it is thought that **203** was not completely stable to chromatography on silica gel.

Entry	Conditions	Ratio of product peak integrals in GC trace or NMR /%						
		SM 189	SiH 190	SiOH 200	Si-N 203	Unidentified products	Dimer 199	Prod 174
15	NBS, RT	9	6	0	61	24	-	-
	2PhMgBr, RT	8	10	5	0	67	-	20
	Crude NMR	9	16	47	0	-	5	23
17	NBS, RT	9	2	11	67	11	-	-
	2PhMgBr, -50 to RT	5	1	21	1	51	-	23
	+1.5PhMgBr	4	1	1	0	50	-	44
	Crude NMR	9	3	3	0	-	3	82*
20	1.5NBS, RT	9	0	3	46	42	-	-

* Flash chromatography gave **174** in 35 % yield.

Table 10

Varying amounts of phenylmagnesium bromide were added to solutions of pure silyl succinimide **203** at RT, Scheme 93. The results are summarised in Table 11. Entry 1 shows that the first equivalent of Grignard reagent consumes all silyl succinimide **203** and the resulting intermediate leads to silanol **200** on work-up. The second equivalent of PhMgBr has little effect on product formation (entry 2), but the third increases it slightly.

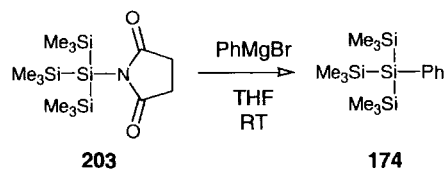

Scheme 93

Entry	Conditions	Ratio by NMR /%		
		Si-N 203	SiOH 200	Prod 174
1	PhMgBr	0	91	9
2	2PhMgBr	12	75	13
3	3PhMgBr	0	74	26

Table 11

The mechanism shown in Scheme 94 is proposed to account for these observations. Intermediates **205** and **206**, when protonated, have $m/z=423$ and such a compound was detected in the reaction mixture of entry 1 by LCMS ($m/z=424$ ($M+H^+$)). Small amounts of product can probably be formed from nucleophilic attack of PhMgBr at silicon at either of the intermediates **205** or **206**, thus accounting for the small proportions of product detected at all stages. It is believed that **206** and **207** form silanol **200** on treatment with water although proposed by-products **208** and **209** could not be detected by GCMS. This could be attributed to their high polarity rendering them unable to pass through the GC column. Reaction of the third equivalent of PhMgBr with dianion **207** to give the desired product looks particularly unlikely as it would involve elimination of a tri-anion, so it is unsurprising that only 26 % product was present in entry 3, Table 11. However, more product was obtained during the 'one-pot' procedures and this is ascribed to stabilisation of eliminated anions by the high quantities of KBr present. Unfortunately, the highest yield of phenyltris(trimethylsilyl)silane **174** during research with NBS was only 35 % so investigation into alternative strategies continued.

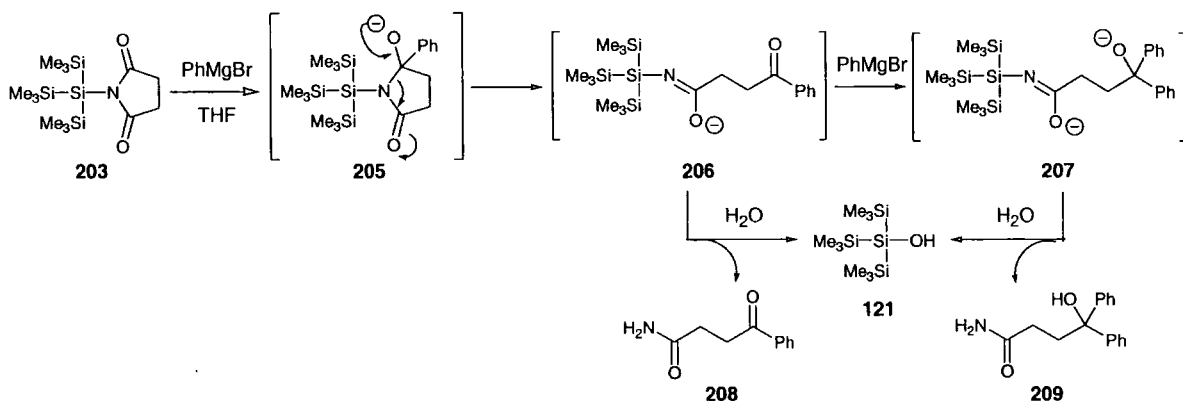

Scheme 94

2.5 Palladium Coupling Reactions

Palladium coupling reactions are used extensively in organic synthesis for the coupling of aromatics and olefins to various hydrocarbon reagents. It was thought that such a strategy could be applied to silicon analogues and be used to couple a phenyl group to the hypersilyl group to afford the desired phenyltris(trimethylsilyl)silane **174**. There are several examples in the literature of palladium-catalysed coupling of silyl groups to olefins and aromatics, all of which involve the scission of silicon-silicon bonds, Scheme 95. The last example is the most relevant to the synthesis of phenyltris(trimethylsilyl)silane **174** from tetrakis(trimethylsilyl)silane **189**, but unfortunately involves heating the substrates in a sealed tube with the carcinogen HMPA for several days.

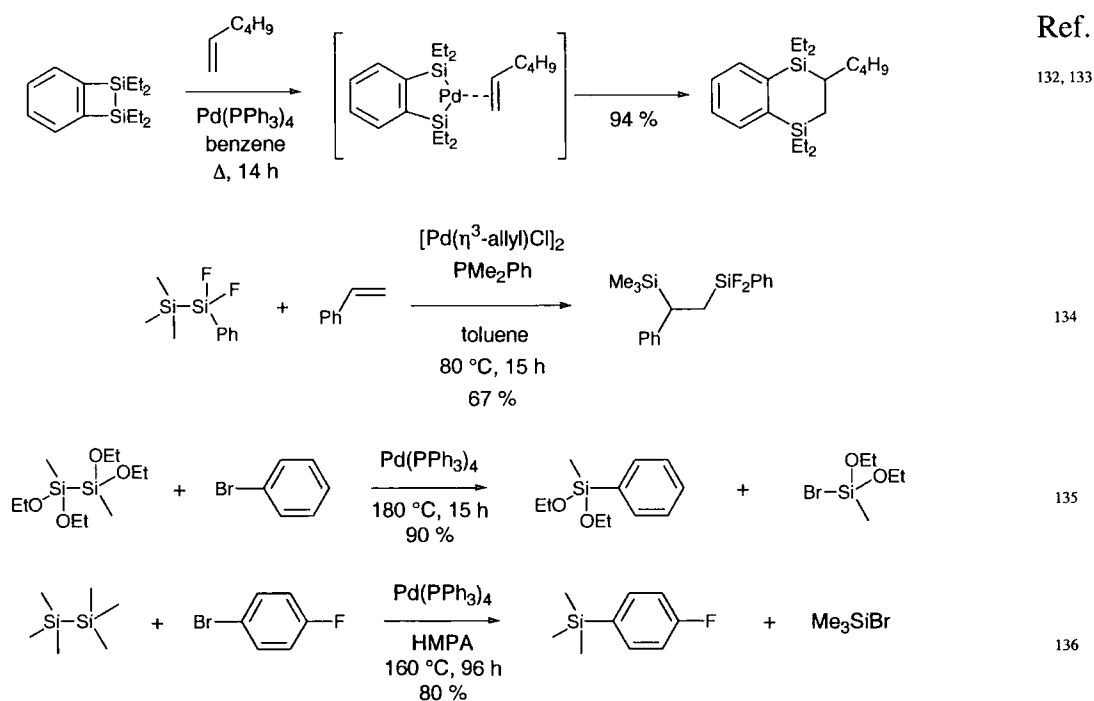

Scheme 95

However, very recent reports by Goossen and Ferwanah have shown that trimethylsilylarenes can be conveniently prepared under very mild conditions by appropriate choice of catalyst ligand for substrate. Thus, electron-poor ligands were used for electron-rich substrates and *vice versa*, Scheme 96.¹³⁷

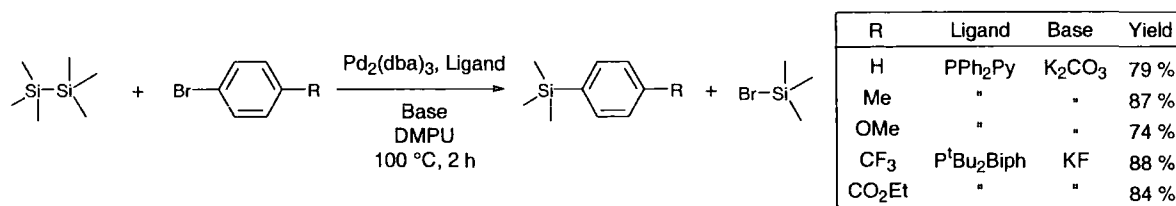

Scheme 96

Unfortunately, an attempt to synthesise phenyltris(trimethylsilyl)silane **174** using this procedure but replacing the disilane with tetrakis(trimethylsilyl)silane **189** afforded an intractable mixture of silylated aromatics. It is speculated that the product is equally vulnerable to Si-Si bond activation by the palladium catalysts producing the observed product mixtures. This result suggested that if the reactivity of the original tris(trimethylsilyl)silane unit could be enhanced, this problem could be avoided. Such enhancement would arise from the coupling of tris(trimethylsilyl)silyl metallics with aryl halides. Hayashi has developed a similar procedure for the palladium- and nickel-catalysed cross-coupling of Grignard reagents **211** with vinyl and aryl bromides, Scheme 97.^{138, 139} Of all the catalysts screened, PdCl₂(dppf) **210** gave the highest yields of **213** because reductive elimination of complex **212** was fast compared with β-hydride elimination.

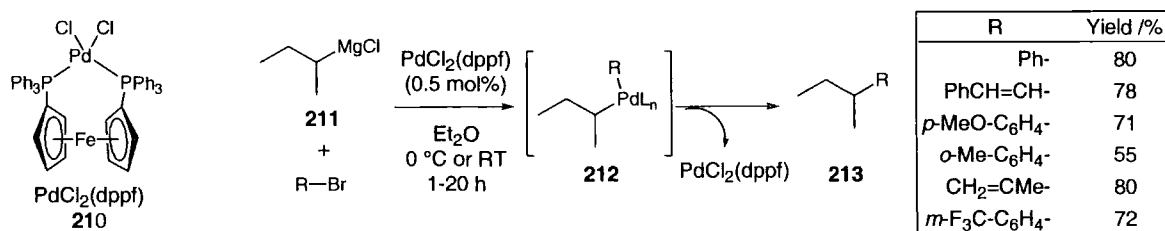

Scheme 97

By analogy, it was postulated that the coupling of silylmagnesium chloride **214** with bromobenzene would afford the desired phenylsilane **174**, *via* the same mechanism, Scheme 98. Thus, silylpotassium **202** was transmetalated in ether using magnesium chloride and the resulting mixture was added to a mixture of bromobenzene and PdCl₂(dppf). The reaction was monitored by GC and was complete after 3 h at RT. GC and NMR spectroscopy of the crude product mixture revealed that **174** had been generated, but as a mixture with dimer **199**, tetrakis(trimethylsilyl)silane **189**, phenyltrimethylsilane (PhSiMe₃) and various unidentified products. In attempts to optimise the reaction, a whole range of conditions were screened, varying solvent (Et₂O or THF), amount of catalyst, temperature, mode of addition, amount of bromobenzene and silyl metallic (K or MgCl). However, little benefit accrued with **174** being detected or isolated in 20-30 % yield in all cases.

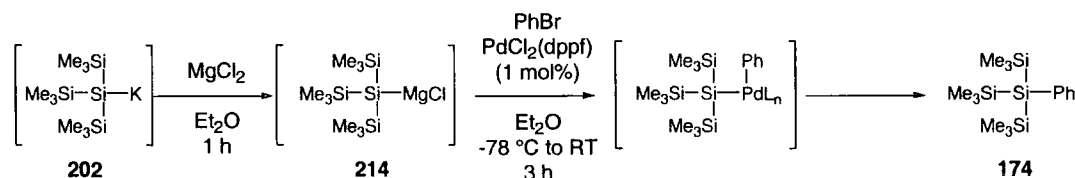

Scheme 98

A control experiment was therefore carried out using no palladium catalyst. A reaction was found to occur on mixing silylpotassium **202** and bromobenzene to afford product **174** in 20 % yield (GC). This suggested that **174** was formed *via* a halogen-metal exchange between

the initial silyl metallic and aryl bromide to form silyl-bromide **191** and phenylpotassium which then combined with elimination of KBr, Scheme 99. The formation of dimer **199** can now be explained as the product from reaction of silylpotassium **202** with bromide **191**. Furthermore, it is proposed that PhSiMe₃ is formed as a result of TMS-abstraction from **174** or **191** by phenylpotassium. This problem was minimised by use of a silyl Grignard reagent in place of silylpotassium **202**, which generates PhMgBr instead of PhK. PhMgBr does not abstract TMS groups as it is less nucleophilic than PhK. Despite this improvement, conversion of the silyl bromide into product was still poor.

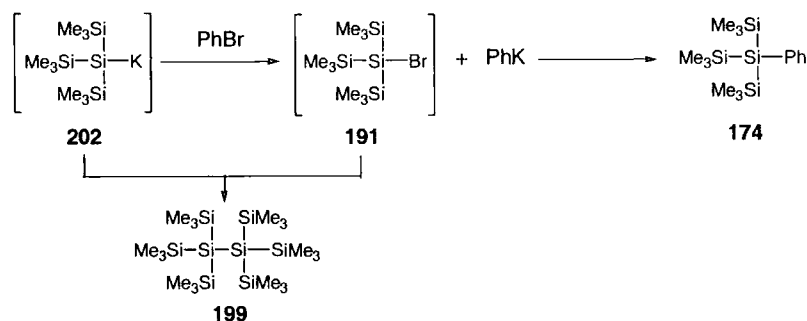

Scheme 99

Speculating that an additional aliquot of an aryl organometallic would accelerate trapping of the intermediate bromide and thus reduce the amount of **199** formed, a mixture of silylpotassium **202** and two equivalents of PhMgBr were combined prior to the addition of bromobenzene. However, **202** and PhMgBr reacted on combination to produce a mixture of tris(trimethylsilyl)silylphenyl magnesium **215**, by elimination of KBr, and the remaining one equivalent of PhMgBr. Silylorganomagnesium compounds, such as **215**, are documented in the literature and are prepared in a similar manner.^{140, 141} Nevertheless, addition of bromobenzene to the mixture of **215** and PhMgBr afforded the desired phenyltris(trimethylsilyl)silane **174** in 65% yield (GC) with minimal by-products. Further refinements involved portion-wise addition of the Grignard reagent and a final reflux to ensure complete displacement of the bromide, Scheme 100. With these conditions a reproducible yield of 60-69 % of the desired silane could be obtained on scales up to 20 g.

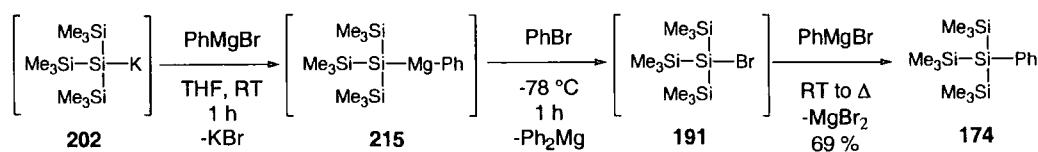

Scheme 100

Having established a viable procedure, its application to other substrates was explored, Table 12. All substrates worked well except for $p\text{-F}_3\text{C-C}_6\text{H}_5$ and this is attributed to the reduced electron density of the Grignard reagent.

Ar	Yield %
$p\text{-MeO-C}_6\text{H}_5$	55
$p\text{-Tol}$	48
$p\text{-Ph}$	69
$p\text{-F-C}_6\text{H}_5$	64
$p\text{-F}_3\text{C-C}_6\text{H}_5$	31

Table 12

As shown in Scheme 100, above, it is speculated that bromobenzene reacts with silylphenyl magnesium **215** with elimination of unreactive diphenylmagnesium. Final substitution, therefore, does not occur until addition of the second equivalent of the Grignard reagent. Hence, it was hypothesised that the intermediate silyl bromide **191** could be intercepted using a different Grignard reagent. However, use of tolylmagnesiumbromide as the Grignard reagent throughout and bromobenzene for the halogen-metal exchange afforded a 3 : 7 mixture of phenyl- and tolyl-substituted products **174** and **216**, respectively, Scheme 101. This is attributed to the Schlenk equilibrium between PhMgTol and PhMgBr which is driven by the magnesium bromide liberated in the final substitution step.^{142, 143}

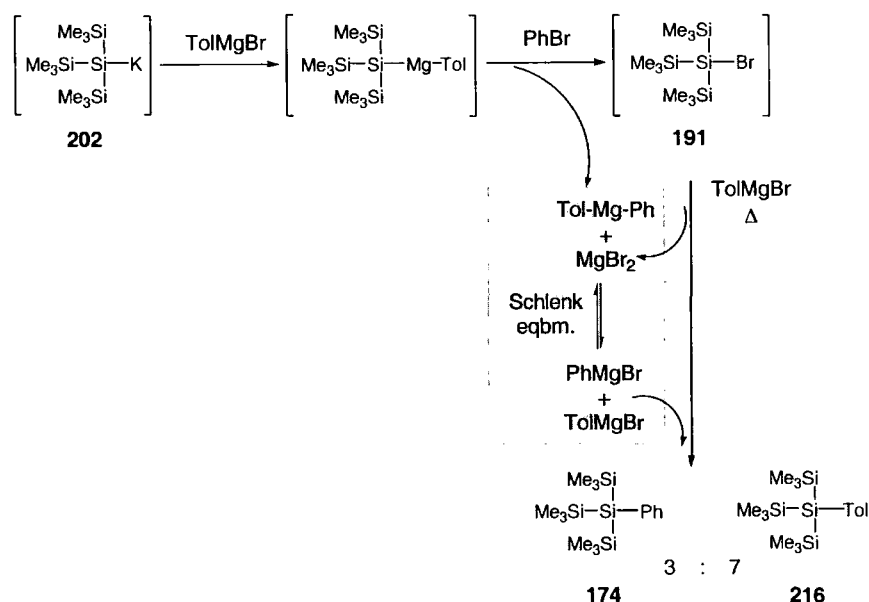

Scheme 101

This observation prompted investigations into the exploitation of the Schlenk equilibrium. Thus, one equivalent of magnesium bromide was added to the reaction mixture after halogen-metal exchange instead of an extra equivalent of Grignard reagent. Refluxing for 16 h gave the desired product in 66 % yield. This was the result of the Schlenk equilibrium

being pushed towards PhMgBr by consumption of diphenylmagnesium. A further experiment showed that only 10 mol% magnesium bromide was necessary to effect a 73 % yield of **174**, Scheme 102.

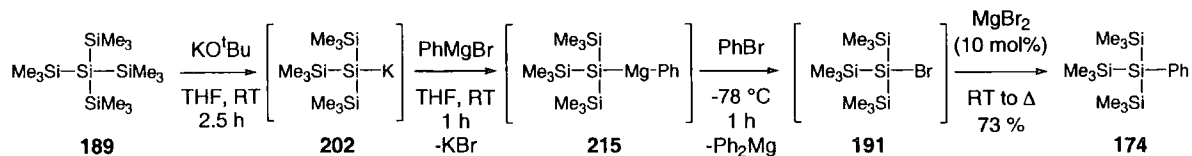

Scheme 102

In conclusion, a synthesis of aryltris(trimethylsilyl)silanes from commercially available or readily synthesisable tetrakis(trimethylsilyl)silane **189** has been developed which is reproducible, 'one-pot', complete in 24 h and high yielding. The important steps include ready formation of silylpotassium **202** with KO^tBu, a halogen-metal exchange and use of a Schlenk equilibrium.

3 Silene Precursors

3.1 Introduction

As discussed in the Project Strategy, Section 1.6 (page 43), the modified Peterson olefination was chosen as the method of silene generation in this project. This involves the generation of transient silenes from isolated, stable silene precursors, a technique which is advantageous because the reaction conditions can be chosen to match those required for the desired reaction of the silene. The necessary precursors are the hydroxyalkylpolysilanes (silyl alcohols), such as **93**, which undergo elimination to form silenes **86** on treatment with base, Scheme 103. Oehme demonstrated that silyl alcohols must be synthesised by reaction of an aldehyde or ketone with silylmagnesium bromide **91** rather than a silyllithium because the intermediate oxymagnesium bromide **92** is stable, whereas the corresponding oxyllithium continues to react to form the silene.^{68, 75, 76, 78, 79} Furthermore, use of less basic silylmagnesium bromides reduces the likelihood of enolisation of the carbonyl compound as they are less basic than silyllithiums.

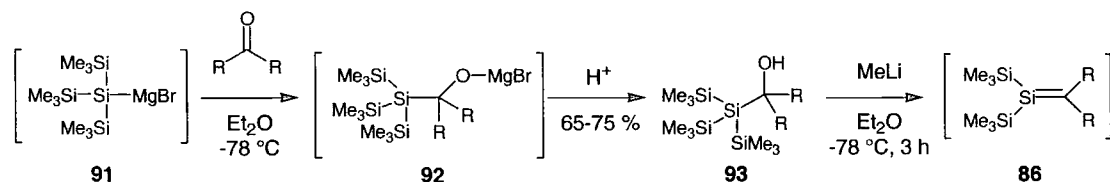

Scheme 103

In this project, the necessary precursors are silyl alcohols **176**. As detailed in Section 1.6 (page 43), two TMS groups are required for rapid conversion into the silene and the phenyl group allows Fleming-Tamao oxidation of silacycle products. Griffiths has shown that Oehme's strategy is readily applicable to the synthesis of **176**, Scheme 104.¹⁰ The phenylsilyllithium **217** was generated by the action of MeLi on phenyltris(trimethylsilyl)silane **174** in THF. The THF was evaporated and exchanged for ether and the silyllithium was transmetallated with magnesium bromide to give silylmagnesium bromide **175**. Addition of the chosen aldehyde at $-78\text{ }^{\circ}\text{C}$ and overnight stirring afforded the silyl alcohols **176** in good yield.

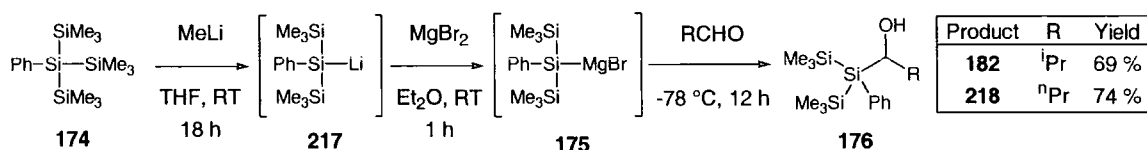

Scheme 104

3.2 Use of the Oehme/Griffiths Synthesis

Initial studies focused on repeating the preparation of isobutyrylsilyl alcohol **182** using MeLi to carry out the initial TMS abstraction. Handling difficulties and the instability of this reagent over long periods of time prompted an attempt to replace MeLi with the more stable, but less reactive, ⁿBuLi. However this did not yield any phenylbis(trimethylsilyl)silane after work-up, indicating no formation of phenylsilyllithium **217**.

Another problem with the synthesis involved the occasional formation of ester **221**, particularly on addition of 2 equivalents of aldehyde. Identification of this by-product was aided by the observation of two isopropyl systems in the ¹H NMR and COSY spectra and an ester carbonyl stretch of 1730 cm⁻¹ in the IR spectrum. **221** could not be thoroughly removed from the silyl alcohol **182** by chromatography. This ester **221** is thought to arise from a Tischenko-type reaction on the alcohol-aldehyde adduct **220**, Scheme 105.¹⁴⁴

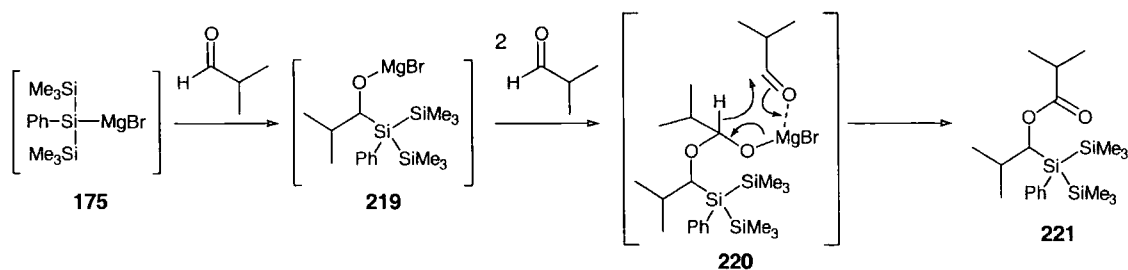

Scheme 105

In order to prove this mechanism, a crossover experiment was designed employing benzaldehyde, Scheme 106. In this, oxymagnesium bromide **219** was generated by treatment of **182** with MeMgBr and then 2 equivalents of benzaldehyde were added. GCMS showed formation of the mixture of products and starting material depicted in the scheme. Despite the low conversion, attributed to poor deprotonation of **182**, cross-ester **224** and benzyl alcohol **225** were formed, thus providing evidence in favour of the Tischenko-type mechanism. Acylsilane **223** was identified by GCMS, CI ($m/z=323$ (MH⁺)) and is the result of a more direct Tischenko-type reaction between oxymagnesium bromide **219** and benzaldehyde *via* magnesium adduct **222** as depicted in the scheme. The lower proportion of this Tischenko-type product is ascribed to greater steric effects because the reaction takes place closer to the alkoxysilane. Attempts to increase the yield of cross-ester **224** involved addition of 0.3 eq. magnesium bromide and use of the more reactive *n*-butyraldehyde, but comparable results were obtained.

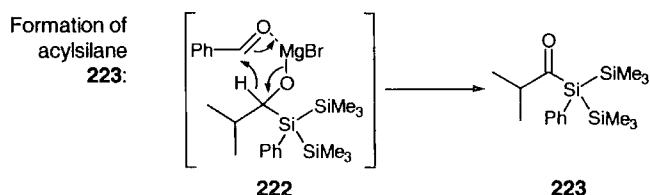
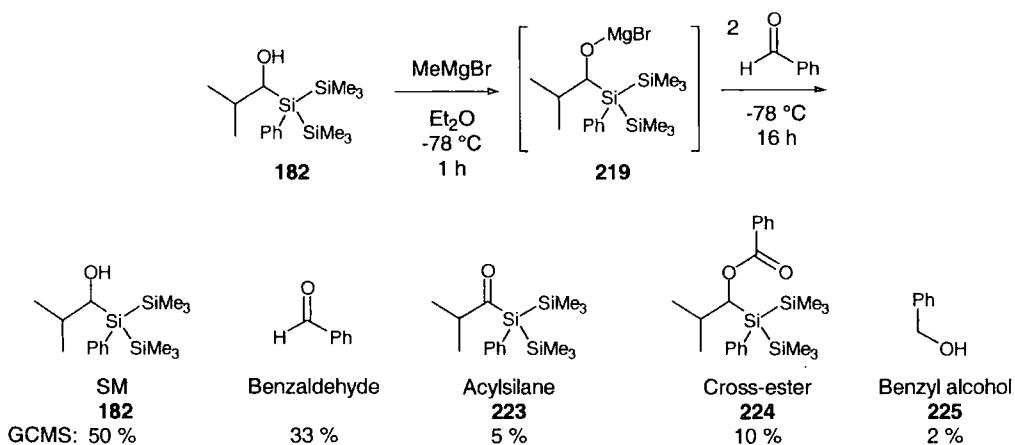

Scheme 106

Endeavours to hydrolyse ester **221** to the alcohol **182** using LiOH, NaOH and MeNH₂ all left the ester unchanged. This is ascribed to extreme steric congestion. Whilst treatment of the mixture of **221** and **182** with LiAlH₄ at RT did lead to consumption of the ester, this process was accompanied by the formation of silyl ether **227** by a 1,3-*Si*, *O*-TMS shift, Scheme 107. However, use of MeLi.LiBr complex cleanly afforded the alcohol **182**. The lack of formation of **227** is attributed to inhibition of the TMS shift by the coordination of LiBr around the resulting oxanion **226**.

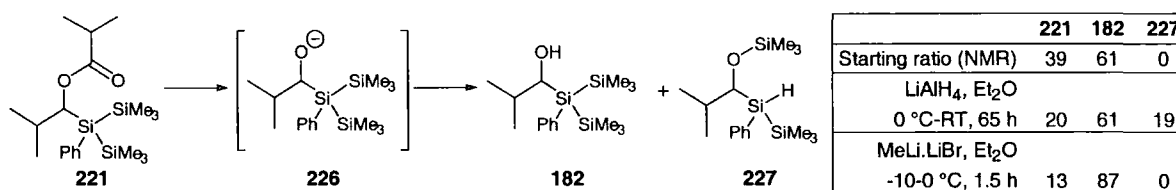

Scheme 107

Given the difficulties in recycling ester **221**, an optimised procedure was developed for the synthesis of alcohol **182** without the ester by-product. This involved the use of less than 1.5 equivalents of the aldehyde and afforded silyl alcohol **182** in 67 % yield on a scale of 31 mmol, Scheme 108. This compound gives a characteristic doublet at 3.79 ppm (CHOH) in the ¹H NMR spectrum and all other data agreed with that given by Griffiths.¹⁰ Small quantities of starting material **174** and phenylbis(trimethylsilyl)silane **228** were also isolated, the latter arising from protonation of silylmagnesium bromide **175** or silyllithium **217**.

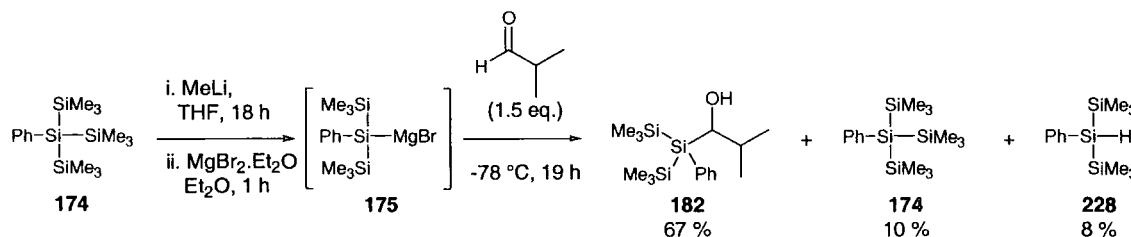

Scheme 108

Following the same procedure, several analogues with varying alkyl groups **218** and **229-231** were synthesised, Figure 6. The low yield of **218** is attributed to the small scale of that reaction (2.4 mmol) and is representative of the synthesis which, in general, was low yielding unless carried out on a large scale (~10 mmol). Of all the steps involved, the solvent swap, involving evaporation of THF *in vacuo*, represents the greatest source of anion quenching. However, this step is essential since the use of ether in the final step is necessary to prevent enolisation of the aldehyde by phenylsilylmagnesium bromide **175** and elimination of the resulting oxymagnesium bromide to the silene. Attempts to avoid the solvent swap by formation of phenylsilyllithium **217** in ether resulted in recovery of starting material and carrying out the whole procedure in DME gave only phenylbis(trimethylsilyl)silane **228** on work-up.

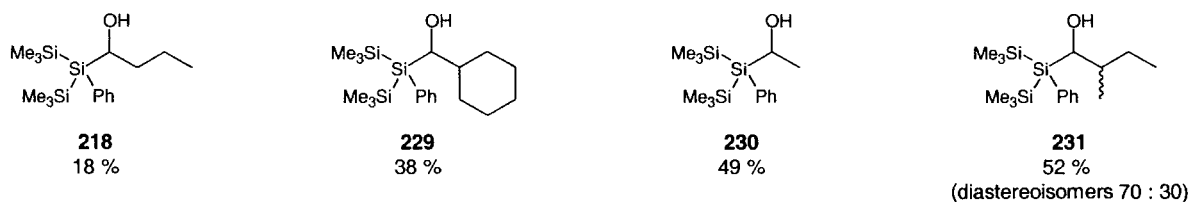
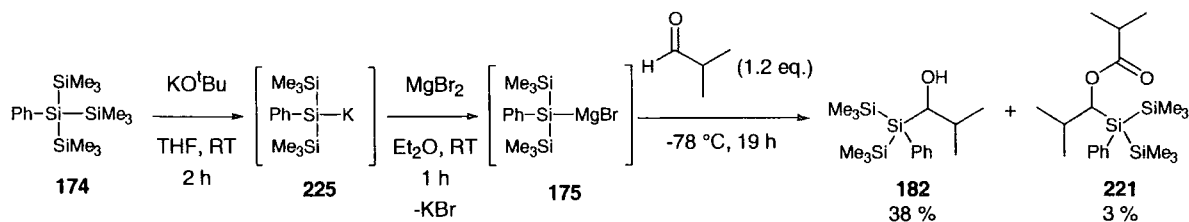

Figure 6

3.3 Adaptation of the Oehme/Griffiths Synthesis

As discussed in Section 2.4.1 (page 52), Marschner has shown that a TMS group can be abstracted from tetrakis(trimethylsilyl)silane with KO^tBu instead of MeLi ,¹³⁰ a technique exploited by us for the synthesis of aryltris(trimethylsilyl)silanes. KO^tBu was also found to react with phenyltris(trimethylsilyl)silane **174** to generate phenylsilylpotassium **225** in 2-3 h, a vast improvement compared to the formation of phenylsilyllithium with MeLi which takes 18 h. However, by using silylpotassium **225** in the synthesis of silyl alcohol **182**, ester **221** was formed in higher proportions and could not be separated from **182**, Scheme 109. This is attributed to the absence of lithium bromide in the reaction mixture. LiBr is normally formed when phenylsilyllithium **217** reacts with magnesium bromide, but with phenylsilylpotassium **225**, potassium bromide is formed instead. In contrast to KBr , LiBr is partially soluble in ether and has Lewis acidic character which enables it to coordinate to the aldehyde and alkoxide. The presence of one whole equivalent of LiBr causes each molecule

of aldehyde and alkoxy magnesium bromide to be coordinated to its own lithium ion and thus minimises the bimolecular interactions necessary for the Tischenko-type reaction described above.



Attempts were therefore made to simulate the original reaction conditions where LiBr is present in the reaction mixture. Thus, LiO^tBu was used in place of KO^tBu, but this failed to undergo any reaction with the starting material **174**. Subsequently, LiBr was added to the reaction mixture after transmetalation from silylpotassium **225** to silylmagnesium bromide **175**. However, on addition of aldehyde, no product was detected and only phenylbis(trimethylsilyl)silane **228** was isolated.

The formation of ester **221** could be minimised by the use of only 1.1 equivalents of aldehyde and this allowed the synthesis of silyl alcohol **182** in 52 % yield. The fact that this yield could not be exceeded prompted a thorough investigation. Table 13 shows the progression of a typical experiment, followed by GC. It is speculated that phenylbis(trimethylsilyl)silane **228** is produced by protonation of a phenylbis(trimethylsilyl)silyl metallic compound, namely magnesium bromide **175**, on work-up. As can be seen, the reaction was complete after 0.5 h, which contrasts with earlier reactions involving MeLi which took ~18 h. After complete reaction, the GC trace showed two major peaks with similar integrals; one for product **182** and one for phenylsilane **228**. Longer reaction times provided no more product **182** and an attempt to drive the reaction further by the addition of an extra equivalent of aldehyde succeeded in consuming more phenylsilyl metallic but led to esterification of a large proportion of the product **182** to afford more **221**.

Time	Ratio of product peak integrals in GC trace /%			
				Unidentified products
0 h 35	38	45	8	9
1 h 35	42	44	9	5
4 h 40	37	51	8	4
26 h 00	37	45	9	9
+1 eq. aldehyde.....				
0 h 05	21	46	22	11
0 h 45	19	43	27	11

Table 13

As stated earlier, the highest yield of **182** obtained using the original synthesis, starting with MeLi, was 67 %. There are only two differences between that reaction and the modified one; the presence of KBr instead of LiBr, which cannot be avoided, and the possible presence of the silyl ether Me₃SiO^tBu which is formed during the initial TMS abstraction by KO^tBu. Although the latter could react with the intermediate oxymagnesium bromide **219** or cause other unforeseen problems, Scheme 110, it is believed to be evaporated (b.p.=103-105 °C)¹⁴⁵ during the solvent swap. This was confirmed by ²⁹Si NMR of the reaction mixture after the solvent swap which revealed only negligible amounts of silyl ether (δ_{Si}=6.34 ppm). Nevertheless, an attempt was made to carry out the initial TMS abstraction with KOMe which would produce a much more volatile silyl ether Me₃SiOMe (b.p.=55-57 °C).¹⁴⁶ Unfortunately, this led to a mixture of products on reaction with **174**, which is ascribed to nucleophilic attack at the central silicon atom as well as the external silyl groups.

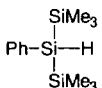
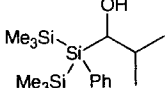
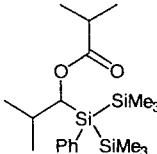
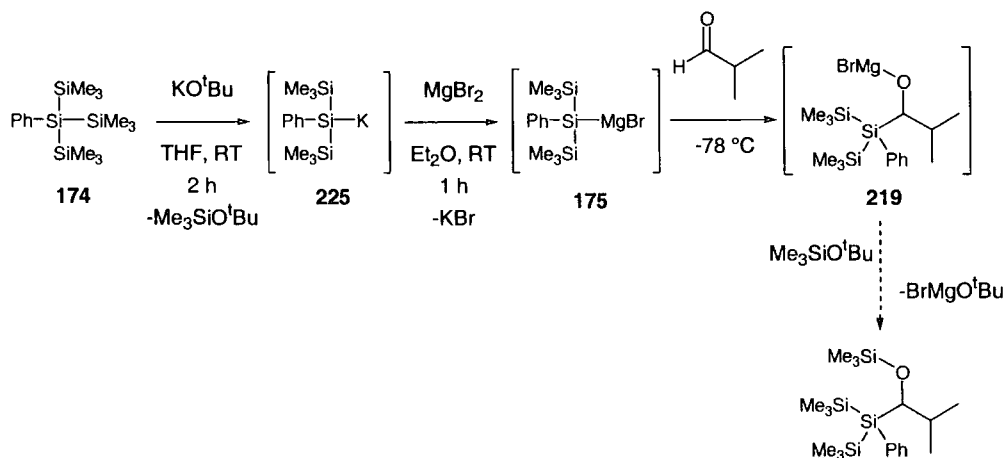

Scheme 110

In order to obtain yields higher than ~50 %, various factors were investigated, including the mode of aldehyde addition, the number of equivalents of magnesium bromide, temperature and the presence of Lewis acids, TiCl_4 and TMSCl . These variations all led to lower yields, decomposition or the isolation of only phenylbis(trimethylsilyl)silane **228**.

The fact that the reaction only proceeds to 50 % conversion suggests that either silylmagnesium bromide **175** and oxymagnesium bromide **219** are in balanced equilibrium or that oxymagnesium bromide **219** is sufficiently basic to deprotonate the remaining aldehyde and that this reaction is faster than the nucleophilic addition of silylmagnesium bromide **175**, Scheme 111. Alcohol **182** is believed to have a relatively high pK_a as it is a secondary alcohol ($\text{pK}_a=16.5$)¹¹ where one of the substituents is the strongly electron-donating polysilyl group. In order to reduce the reactivity/basicity of the intermediate oxanion, several different silyl metallic reagents were screened using alternative metal salts in place of MgBr_2 , Table 14. Transmetalation was considered to have occurred on observation of a colour change of the red/brown silylpotassium solution and formation of a precipitate. Entries 3 and 4 were attempts to use Grignard reagents in place of metal salts, in a similar fashion as was done during concurrent work on the synthesis of aryltris(trimethylsilyl)silanes described in Section 2.5 (page 60). Unfortunately, no salt gave advantages over MgBr_2 .

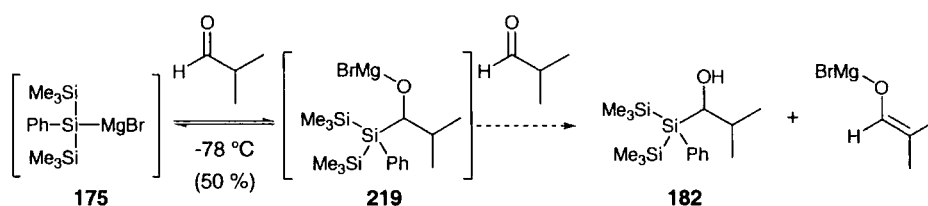

Scheme 111

Entry	Metal salt and solvent		Desired silyl metallic	Result
1	MgCl ₂	Et ₂ O	Si-MgCl	No transmetallation.
2	MgI ₂	Et ₂ O	Si-MgI	Increased formation of ester 221 .
3	PhMgBr	THF	Si-MgPh	Mixture of products including PhCH(OH) ^t Pr.
4	PhMgBr	Et ₂ O	Si-MgPh	Trace desired product in similar mixture to 3.
5	ZnBr ₂	Et ₂ O	Si-ZnBr	Decomposition at transmetallation stage.
6	ZnCl ₂	Et ₂ O	Si-ZnCl	Decomposition at transmetallation stage.
7	CeCl ₃	Et ₂ O	Si-CeCl ₂	No transmetallation.
8	Yb(OTf) ₃ ^{147, 148}	Et ₂ O	Si-Yb(OTf) ₂	Mixture of products after aldehyde addition.
9	Yb(OTf) ₃	THF	Si-Yb(OTf) ₂	Mixture of products after aldehyde addition.
10	CuI (0.5 eq.) ^{149, 150}	Et ₂ O	Si) ₂ CuK	No reaction with aldehyde, mixture products on warming to RT.

Table 14

To circumvent the problem of enolisation, **175** was reacted with the non-enolisable pivaldehyde. This reaction behaved in an identical manner as that with isobutyraldehyde with the reaction stopping at around 50 % conversion (GC) and the formation of trace amounts of ester **233** and acylsilane **234**,^{*} Scheme 112. This was strong evidence that the reaction was encumbered by a problem other than enolisation of the aldehyde.

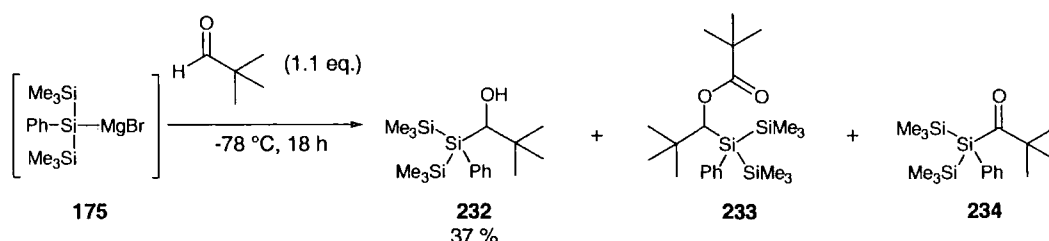

Scheme 112

A new explanation for reaction arrest at 50 % conversion was proposed involving a Schlenk-type equilibrium between oxymagnesium bromide **219** and magnesium adduct **235** which lies almost entirely to the right, Scheme 113. Carbon analogues of such adducts have been shown to exist.¹⁵¹ Adduct **235** is suggested to be significantly more stable than silylmagnesium bromide **175**, due to withdrawal of electron density by the oxygen atom, such that it will not react with the remaining 0.5 equivalents of aldehyde. Attempts to break up the adduct by addition of either TMEDA or DMPU gave no further reaction.¹⁵²⁻¹⁵⁴

* Interestingly, if the reaction was carried out at RT, this by-product **234** was produced and isolated in 36 % yield.

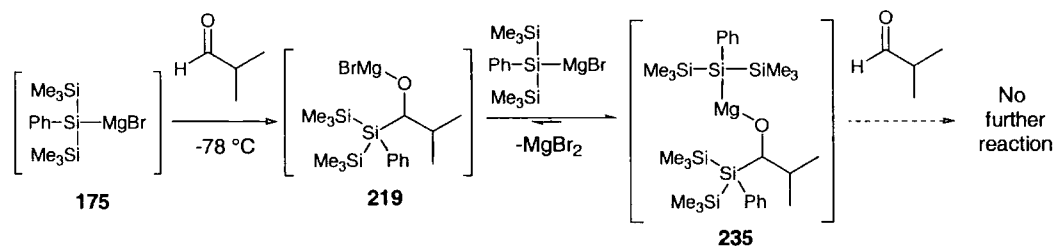

Scheme 113

In order to prove the above mechanism, the reaction with isobutyraldehyde was repeated and aliquots of the reaction mixture were removed at each stage and analysed by ^{29}Si NMR, referenced to tetramethylsilane. The results are shown in Figure 7 which includes the whole spectrum on the right and an expansion of the TMS region on the left. Spectrum 3 shows that the formation of silylpotassium **225** is almost quantitative as only negligible amounts of the starting material **174** (spectrum 1) are present. Furthermore, as discussed earlier, this spectrum was taken after the solvent-swap to ether and shows that only negligible amounts of $\text{Me}_3\text{SiO}^t\text{Bu}$ (spectrum 2) remain. Spectrum 5 shows that transmetalation with MgBr_2 also proceeds to completion as no silylpotassium (spectrum 3) can be seen. However some silane **228** (spectrum 4) is detectable and could have arisen during transfer to the NMR tube or be the result of traces of water in the magnesium bromide. Spectrum 7 shows the result of an attempt to synthesise oxymagnesium bromide **219** by treatment of the silyl alcohol **182** (spectrum 8) with MeMgBr . Unfortunately, this was not a clean reaction so the peaks cannot be assigned, but no silylmagnesium bromide **175** can be seen which is evidence against a balanced equilibrium between **219** and **175**. Spectrum 6 was taken after addition of aldehyde to silylmagnesium bromide **175**. Unfortunately, this reaction mixture contained so much precipitate that it could not be decanted off prior to the NMR spectrum being taken which led to peak broadening. Nevertheless, the spectrum shows the presence of silane **228** which is evidence for protonation of silylmagnesium bromide **175** by the aldehyde. No peak for the central silicon atom of silylmagnesium bromide **175** can be detected in spectrum 6 although a peak corresponding to the TMS groups of **175** can be seen. If the latter is coincidental, then this is evidence for the consumption of silylmagnesium bromide **175** by formation of adduct **235**. However, it could also imply that all of the silylmagnesium bromide has reacted nucleophilically with the aldehyde or been protonated by it to form silane **228**. Overall, this experiment is inconclusive and future ^{29}Si NMR experiments would include the use of the non-enolisable pivaldehyde and improved methods for removing precipitated salts prior to NMR.

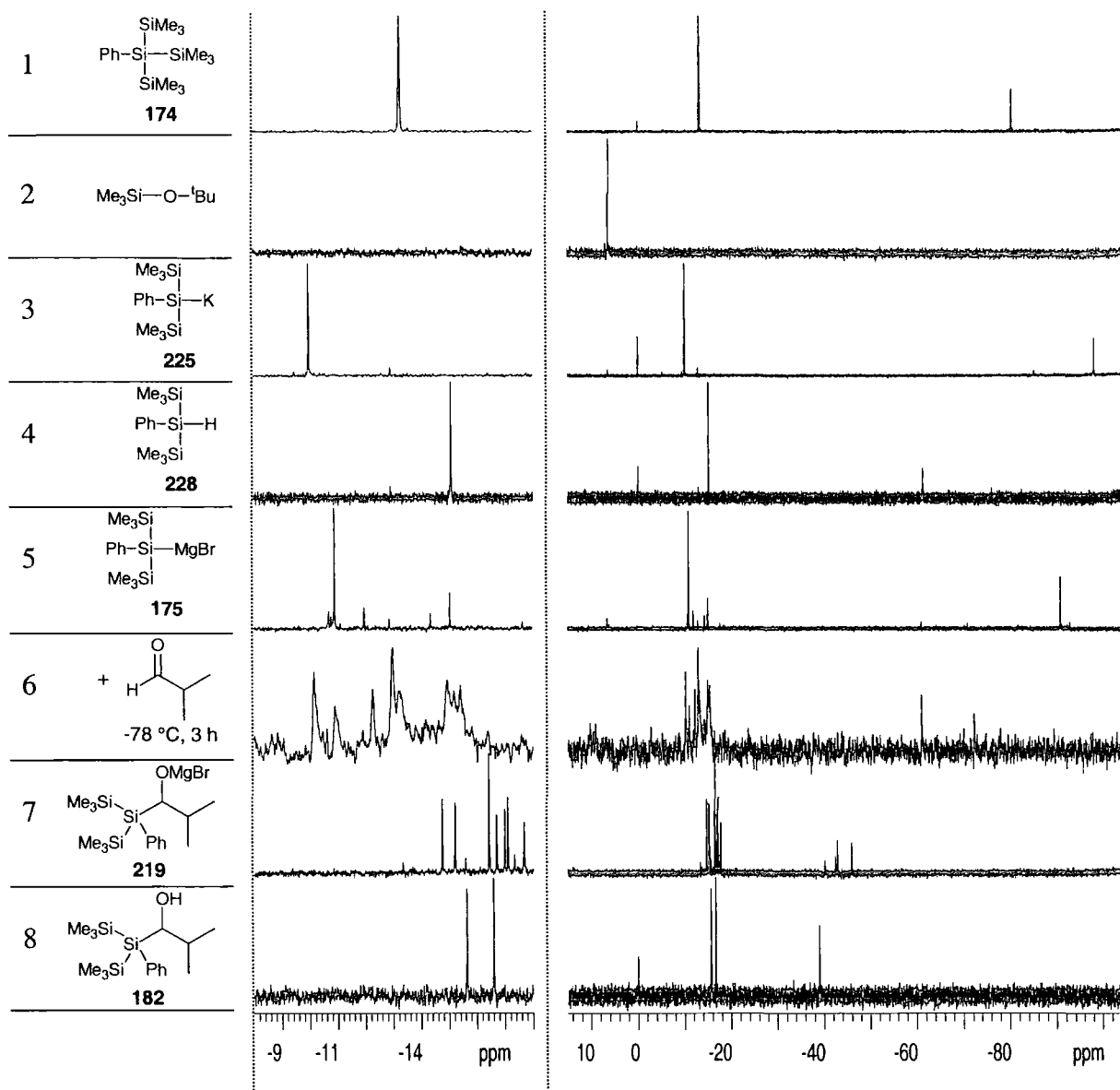

Figure 7

In conclusion, although this synthesis did not provide silyl alcohols in very high yields, it was considerably simpler to carry out than the MeLi variation. It was therefore used to synthesise various alkyl substituted silyl alcohols, all of which are shown in Figure 8. In addition, variation of the aromatic group in the starting material was successful in the synthesis of *p*-methoxyphenylsilyl alcohol **237**. However, an attempt to synthesise the analogous trifluoromethylphenylsilyl alcohol failed owing to KO^tBu -induced degradation of the starting aryltris(trimethylsilyl)silane.

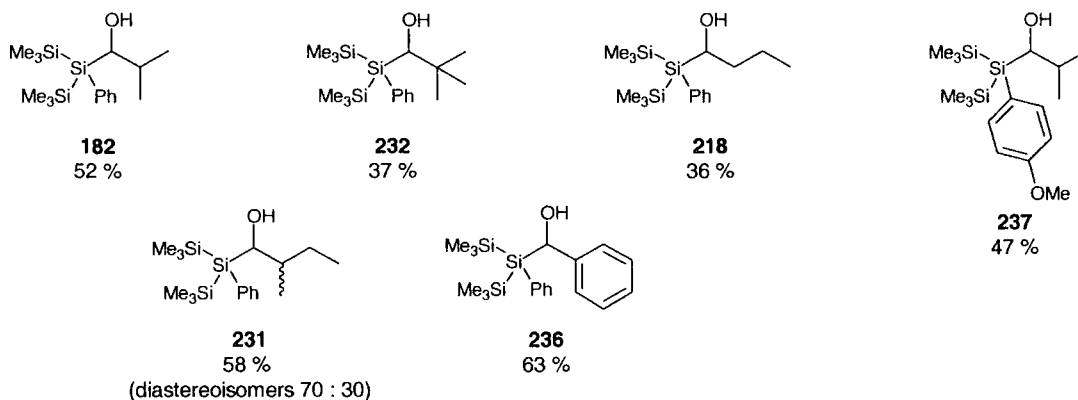
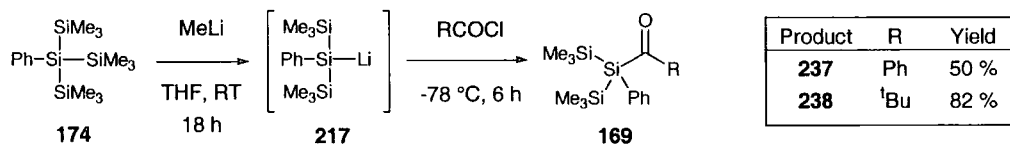

Figure 8

3.4 Alternative Synthesis via Acylpolysilanes

The low yields of silyl alcohols obtained using the above synthesis prompted investigations into an alternative generation of silyl alcohols. This involved the synthesis and reduction of acylpolysilanes. Unlike silyl alcohols, these can be synthesised by direct addition of silyllithium reagents to acid chlorides.^{57, 155} Griffiths showed that acylphenyltrisilanes **237** and **238** could be readily synthesised by this technique, although difficulties were encountered with enolisable acid chlorides, Scheme 114.¹⁰



Scheme 114

Nevertheless, the reaction between phenylsilylpotassium **225** and isobutyryl chloride was carried out and generated a mixture of products which included the desired acylsilane **223**. Optimisation of the reaction conditions showed the best results to be obtained when **225** was added dropwise at $-78\text{ }^{\circ}\text{C}$ to a solution of 3 equivalents of acid chloride, Scheme 115.

A range of reducing agents were screened with the crude mixture of **223** including $\text{BH}_3\cdot\text{THF}$,^{156, 157} NaBH_4 ,^{158, 159} LiBH_4 and LiAlH_4 in ether and THF. The best results were obtained with LiAlH_4 so this reaction was repeated on a larger scale of 2 mmol. However, this afforded silyl alcohol **182** in only 29 % yield, Scheme 115. Given the lack of improvement on the existing synthesis using aldehydes, this method was not explored further.

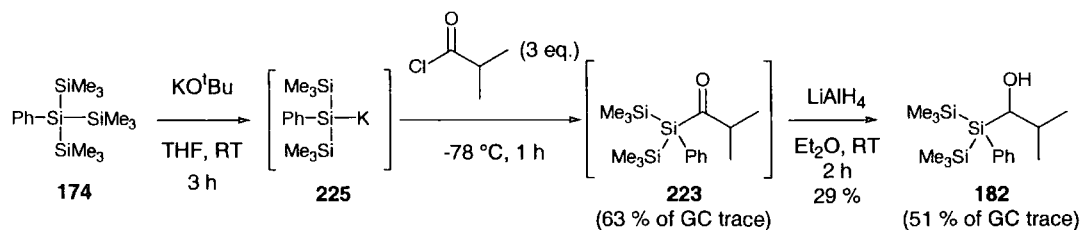

Scheme 115

3.5 Conclusion

The synthesis of silyl alcohols, the necessary precursors to silenes, through the reaction of phenylsilylmagnesium bromide **175** with aldehydes is a 'one-pot' multi-step reaction which has been optimised to afford the products in around 50 % yield within 24 h. The key steps involved formation of phenylbis(trimethylsilyl)silylpotassium by treatment of tetrakis(trimethylsilyl)silane with KO^tBu, transmetalation to the corresponding magnesium bromide and nucleophilic addition to an aldehyde. Unfortunately, all attempts to induce full conversion to the silyl alcohol were unsuccessful but the synthesis did provide sufficient material for subsequent research into silene generation.

4 Silene Generation

4.1 Introduction

As described in Section 1.6 (page 43) of Chapter 1, the modified Peterson olefination was chosen to generate silenes. Of the three variations available (see Section 1.4.6.3, page 18), that employing the deprotonation of silene precursors; silyl alcohols, such as **93**, offers most versatility and simplicity. This technique was invented by Oehme who also showed that the resulting silenes **86** could be trapped by dienes to afford silacycles **237**, Scheme 116.⁶⁸ As discussed in Section 1.4.6.3 (page 22), Oehme also showed that replacing MeLi with NaH, or using either base in THF, gave no silene **86**. Instead, the reaction stopped at silyl anion intermediate **81** which was detected as the protonated product after work-up.

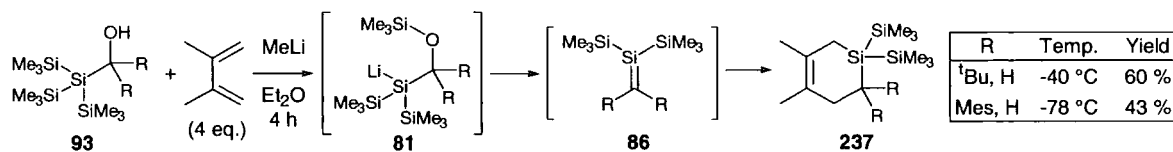

Scheme 116

Preliminary studies by Griffiths adapted Oehme's methodology to incorporate a phenyl group in the precursor and therefore the resulting silacycles. Thus, following the precedent established by Oehme, silyl alcohol **182** was treated with MeLi in the presence of 1,3-pentadiene at -78 °C. However, it was found necessary to warm the mixture to -30 °C and stir for 18 h to afford the silacycle **183** in 66 % yield, Scheme 117.¹⁰ Silacycle **239** was synthesised in the same manner by trapping with 2,3-dimethylbutadiene. Conversely, one attempt at silene generation from *n*-butylsilyl alcohol led only to the recovery of starting material. This result is not ascribed to the difference in substrate but to the capriciousness of the general reaction.

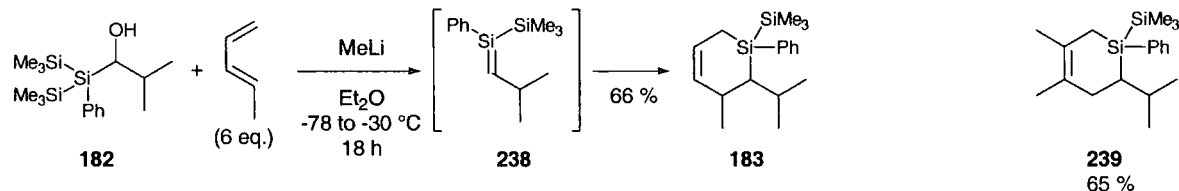

Scheme 117

In the absence of a trapping agent, silene **238** dimerised to afford a [2+2] species **240** or **241**, Scheme 118. In addition, these dimers were the only products detected when cyclohexadiene and cyclopentadiene were employed as trapping agents. This is attributed to inhibition of the [4+2] cycloaddition by steric interactions between the allylic protons of

these dienes and the silene, a problem also encountered by Auner when using cyclohexadiene as the silenophile (see Section 1.5.3.4, page 36).^{90, 91}

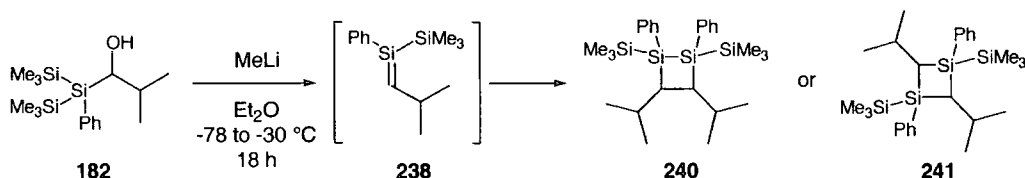

Scheme 118

In an attempt to optimise the process, Griffiths also tried ⁿBuLi and LHMDS as alternative bases to MeLi, but obtained the same result as Oehme, namely, the isolation of silane **227** on work-up due to reaction arrest at the intermediate silyllithium **243**, Scheme 119.

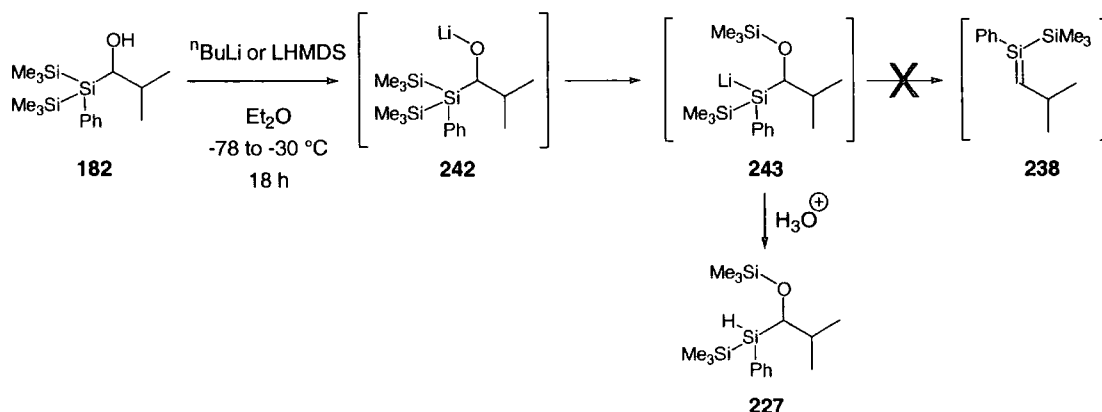

Scheme 119

This work established the validity of the modified Peterson olefination for silene generation in the presence of dienes as a means to synthesise silacycles. However, several points remained to be addressed:

1. The failure of alternative bases to generate silenes.
2. The reaction using MeLi could not be reliably reproduced.
3. The applicability of the reaction to a range of substituted dienes and silyl alcohols.
4. The stereochemistry of the resulting silacycles.

4.2 Alternative Bases and Mechanistic Studies

4.2.1 Use of MeLi

Initial studies focused on repeating the work carried out by Griffiths. Hence, silyl alcohol **182** was treated with MeLi in the presence of 1,3-pentadiene. After several attempts, silacycle **183** was isolated in 52 % yield, Scheme 120. Mixtures of starting material **182**, silanes **227** and **244** were also isolated, identified by the characteristic NMR signals given in the scheme. The latter silane **244** is thought to be formed by hydrolysis of silyl ether **227** on

work-up or on silica gel. The occurrence of these by-products is evidence for the mechanism shown in Scheme 118 involving elimination of Me_3SiOLi from silyllithium **243**.

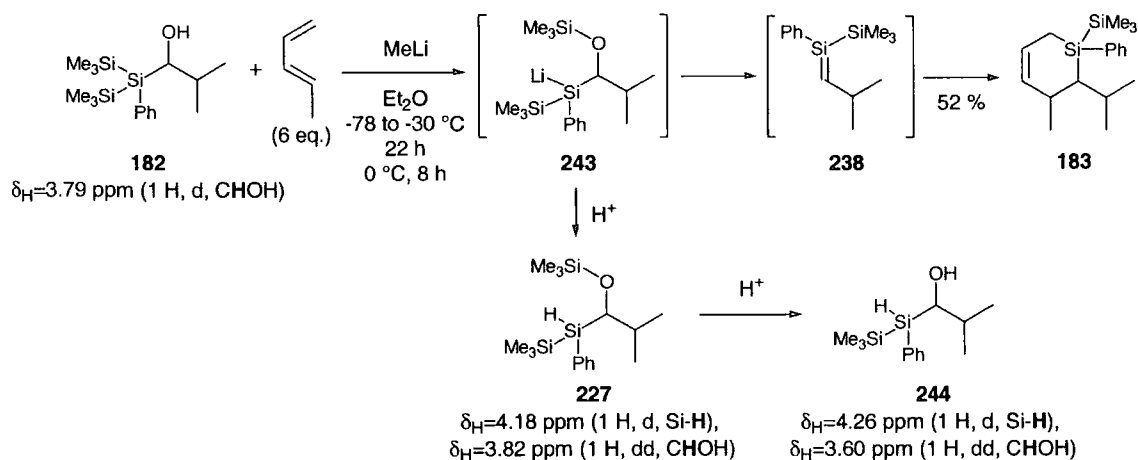

Scheme 120

4.2.2 Use of Alternative Bases

The above mechanism suggests that silene generation should occur with any base of sufficient strength to deprotonate silyl alcohol **182**. In view of this, and the irregularity of silene generation with MeLi, a range of bases were screened under various conditions. Table 15 shows the ratio of products detected in the crude NMR spectrum for the reaction with each base. Entries 1-3 highlight the unreliability of MeLi for silene generation although ironically, no other base led to generation of silacyclopentane **183**, which implies no other base gave silene. Entries 4-7 show that the reaction proceeds through the 1,3-Si, O TMS migration with $^n\text{BuLi}$ and NaH but the resulting silyl anion does not eliminate Me_3SiO^- to give silene, hence silane **227** is produced on work-up. Entry 7 shows that the migration can be forced to completion by the use of higher temperatures. Entries 8-10 involve bases which are too weak to sufficiently deprotonate the silyl alcohol **182**, which is believed to have a high pK_a due to electron donation by the electropositive silyl group.

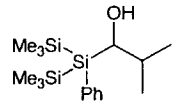
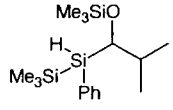
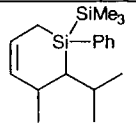
Entry	Base	Temp. /°C	Time /h	Molar % by NMR		
				 182	 227	 183
1	MeLi	-78 to -30	22	0	9	91 (52%)
2	MeLi	-78 to -30	18	83	17	0
3	MeLi	-78 to -30	20	72	8	20
4	ⁿ BuLi	-78 to -30	18	52	48	0
5	NaH	-78 to -30 to RT	21, 18	69	31	0
6	2 NaH	-78 to -30	87	18	82	0
7	2 NaH	-78 to reflux	7	0	100	0
8	LiH	-78 to -30	18	95	5	0
9	2 LiH	-78 to reflux	41	95	5	0
10	LiOH	-78 to -30	18	100	0	0
11	TBAF	-78 to -30	18	90*	0	0
12	Me ₃ SiOK	-78 to -20	21	93	7	0

*Approximately 10 % decomposition

Table 15

The use of TBAF and Me₃SiOK in entries 11-12 were tests of an alternative mechanistic hypothesis which involved nucleophilic attack at a TMS group of silyl alcohol **182** and elimination of hydroxide to produce silene **238**, Scheme 121. This mechanism was proposed to explain why only MeLi produced silene; being a stronger nucleophile than ⁿBuLi where steric considerations reduce nucleophilicity. Both TBAF and Me₃SiOK are known to exhibit nucleophilic reactivity towards silicon centres. However in neither case was the silene generated. Speculating that a better leaving group than hydroxide was required, attempts were made to convert the alcohol into the tosylate and mesylate⁶⁰. Although these reactions failed due to the extreme steric congestion around the silyl alcohol **182**, the corresponding trifluoroacetate **245** could be synthesised. However, reaction of this with MeLi generated silyl alcohol **182**, due to nucleophilic attack at the ester, and treatment of **245** with TBAF yielded a mixture of products, none of which could be ascribed to silene generation. Although not conclusive, these experiments provided evidence against the nucleophile mechanism and a novel explanation was sought for the exclusive success of MeLi. Interestingly, in the original development of the Peterson olefination, it was also found necessary to test such a mechanism, but Peterson ruled it out because no base-TMS adduct could be detected.⁶³

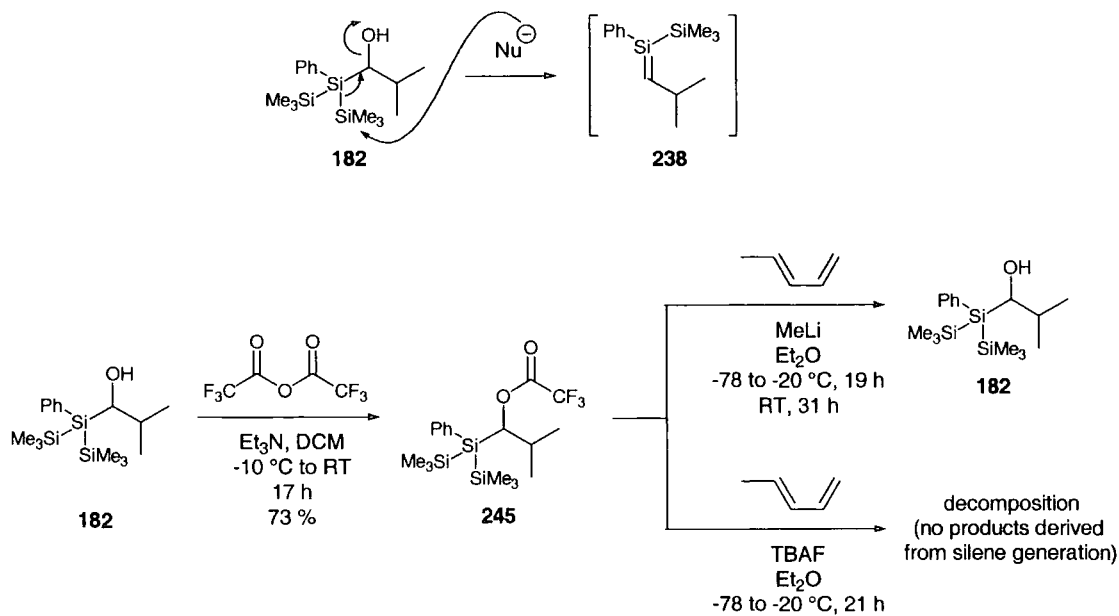

4.2.3 Use of Lithium Salt Additives

It was speculated that silene generation occurred exclusively when MeLi was employed as base because of an impurity in the commercial solution. The 1.6 M solution of MeLi in ether that had been used throughout this research was described as ‘low chloride’ and as containing approximately 6 % LiBr. In contrast, the ⁿBuLi used above was a 1.6 M solution in hexane, in which solvent lithium salts are insoluble and so absent. This requirement for lithium salts would also explain the capriciousness of the reaction with MeLi because different commercial batches could contain varying amounts of the impurity. A search of the literature revealed that Oehme had found the presence of LiBr to have an effect on the rate of silene generation;⁷⁹ formation of silene **248**, by treatment of silyl alcohol **246** with a Grignard reagent, normally proceeded extremely slowly, but in the presence of LiBr, the reaction was complete within a few hours, Scheme 122. Unfortunately, Oehme did not offer an explanation for this observation.

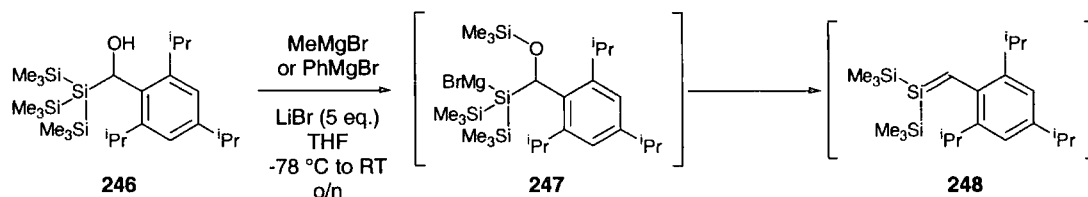

A thorough investigation into the addition of lithium salts to the reaction mixture of silyl alcohol **182**, 1,3-pentadiene and base is summarised in Table 16. The salts were added either prior to the addition of base (Method A) or after complete conversion to silylmethyl **249** (Method B), Scheme 123. Entry 1 describes the conversion to silylmethyl **249** using

NaH followed by the addition of over 2 equivalents of LiCl to include transmetalation of **249** to the silyllithium. However, no elimination of Me_3SiOLi took place so no silene trapping was detected and this is attributed to the insolubility of LiCl. Entries 3-8 show attempts to simulate successful reactions using MeLi by the addition of LiBr prior to base. Unfortunately, the presence of LiBr inhibited the 1,3-Si, O-migration so less silyllithium **249** was produced and it appears that none had time to undergo the elimination to silene. Finally, it was discovered that low-temperature-addition of LiBr after complete conversion of silyl alcohol **182** into silyllithium **249** with ${}^n\text{BuLi}$ at RT for 3 h afforded silene (entry 9) and that the LiBr could be used in catalytic quantities (entry 10). Similar experiments with LiI were also successful but this reagent was harder to dry due to its lower temperature of sublimation.

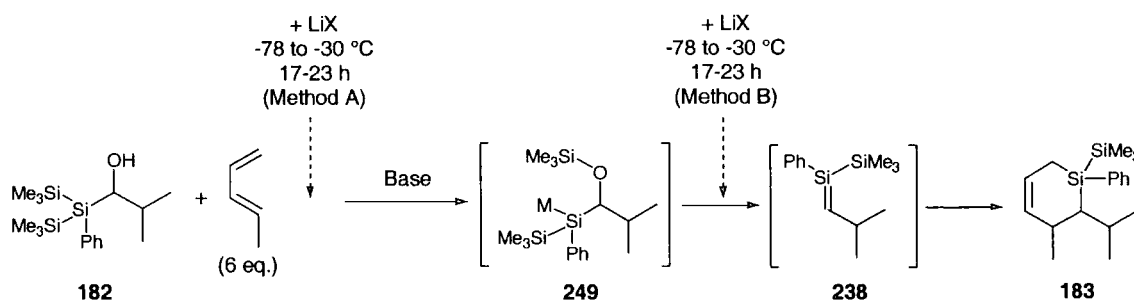



Entry	Base	Additive	Method	Molar % by NMR		
				 182	 227	 183
1	2 NaH	LiCl (220 %)	B	12	88	0
2	1.7 ${}^n\text{BuLi}$	LiBr (70 %)	A	100	0	0
3	${}^n\text{BuLi}$	None	-	52	48	0
4	${}^n\text{BuLi}$	LiCl (60 %)	A	71	29	0
5	${}^n\text{BuLi}$	LiBr (100 %)	A	86	14	0
6	${}^n\text{BuLi}$	LiBr (30 %)	A	90	10	0
7	${}^n\text{BuLi}$	LiBr (10 %)	A	36	64	0
8	${}^n\text{BuLi}$	LiBr (6 %)	A	60	40	0
9	${}^n\text{BuLi}$	LiBr (100 %)	B	7	17	76 (50%)
10	${}^n\text{BuLi}$	LiBr (10 %)	B	7	21	72

Table 16

The mechanism shown in Scheme 124, based on the Lewis acidic character of LiBr, is proposed to explain all of the observations made during this research. Most importantly,

silyllithium **243** does not eliminate Me_3SiOLi unless a catalytic amount of LiBr is present to coordinate to the oxygen atom, to give **251**, and enhance the ability of that group to leave. However if the LiBr is present before formation of **243**, then the 1,3-*Si, O* TMS migration is inhibited by aggregation of the oxanion **242** by coordination of LiBr **250**. Occasionally, the amount of LiBr present in a batch of MeLi was sufficient to promote the elimination without inhibiting the migration, but attempts to simulate this with $^n\text{BuLi}$ by addition of 6, 10, 30 % LiBr at the same time as the base (entries 6-8, above) were unsuccessful. This mechanism can also be used to explain why the elimination does not occur in THF; this solvent is a strong electron donor and so coordinates to LiBr more strongly than the oxygen atom of **243**.

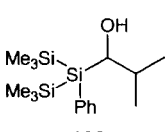
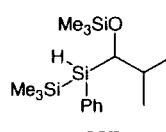

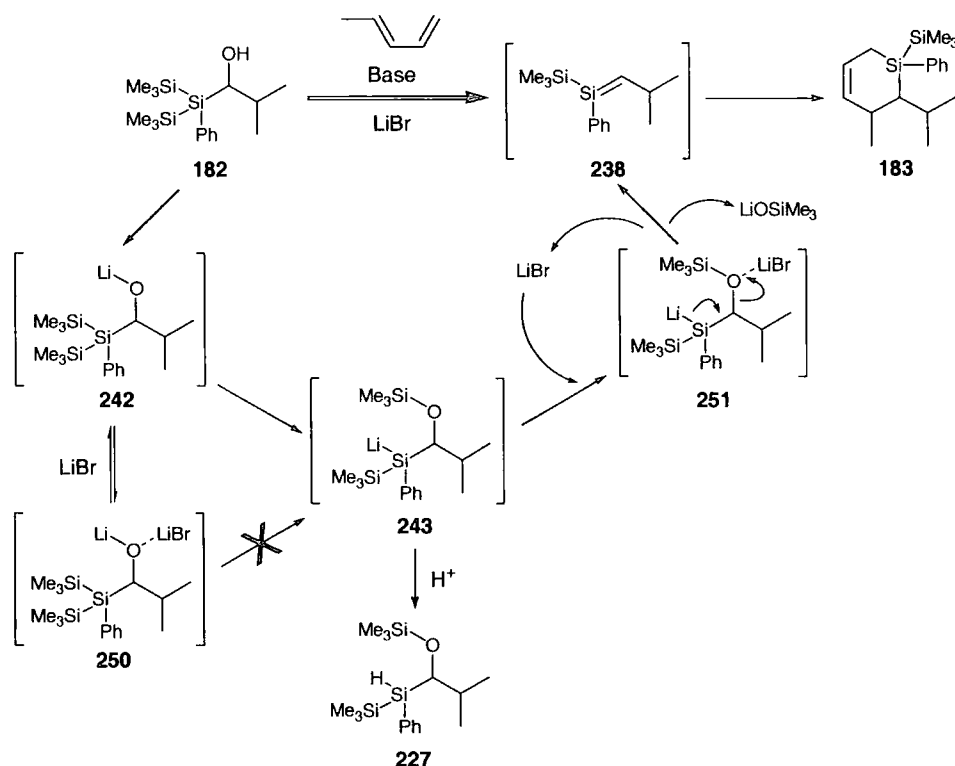
4.2.4 Use of *p*-Methoxyphenyl Substituted Silyl Alcohol

It was speculated that if the phenyl group of the silyl alcohol bore an electron-donating substituent, then the silyllithium resulting from treatment with base would spontaneously eliminate Me_3SiOLi without addition of Lewis acidic LiBr . Silyl alcohol **237** was therefore treated with $^n\text{BuLi}$ in the presence of 1,3-pentadiene, Scheme 125. A small amount of silacycle **255** (8 %) was detected in the NMR spectrum of the crude material indicating that the hypothesis was correct, but conversion was far from complete. Unfortunately, attempts to drive the reaction to completion by warming to RT were unsuccessful and carrying out the reaction in the ordinary manner, by treatment with $^n\text{BuLi}$ followed by the addition of a

catalytic amount of LiBr, had no effect. The latter result is attributed to coordination of the LiBr to the methoxy group of the aromatic ether rather than the more hindered OSiMe₃ group.

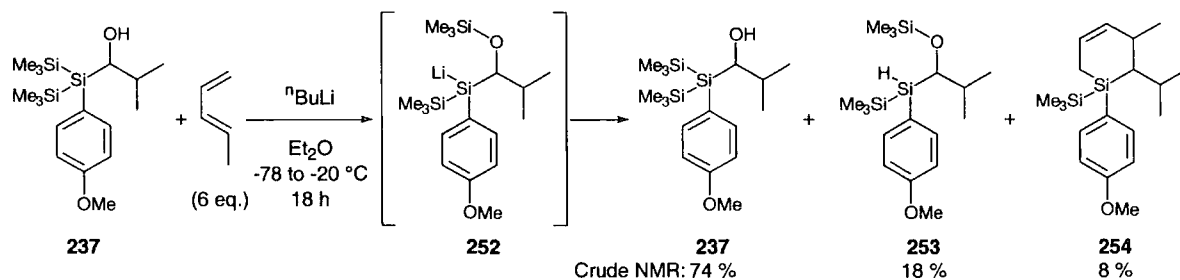

Scheme 125

4.3 Conclusion

Elucidation of the mechanism of silene generation involving LiBr provided a robust and reproducible method for the generation of silenes in the presence of dienes, Scheme 126. This allowed various dienes and silyl alcohols to be screened and the resulting silacycles to be elaborated into synthetically useful building blocks. This research is discussed in the subsequent chapter.

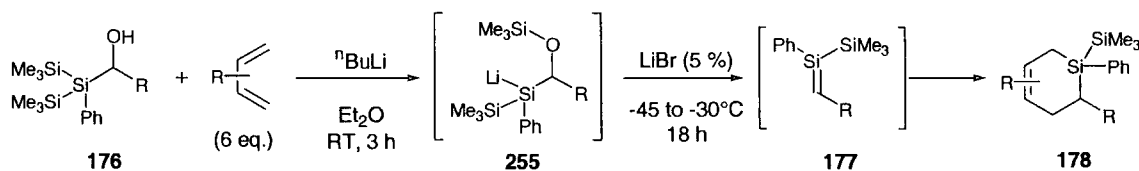

Scheme 126

5 Silacycles

5.1 Introduction

5.1.1 Silacycle Synthesis and Elaboration

As described in Section 4.2.3 (page 80) of Chapter 4, a new, reliable variation of the modified Peterson olefination, involving LiBr, for the generation of silenes was developed which allowed the synthesis of 6-membered silacycles by diene trapping. This chapter describes the application of the reaction to a range of dienes and various silenes in order to validate the method as a novel synthetic technique. The chemical elaboration of each silacycle will also be discussed, precedent for which was established by Griffiths, using silacycle **183**, Scheme 127.¹⁰ Firstly, hydrogenation in toluene yielded the saturated silacycle **255**. The use of toluene as solvent was necessary because ethanol and ethyl acetate apparently led to the rapid decomposition of the silacycle **183**. Next, the silyl unit of silacycle **255** was excised in 2 steps, exploiting the reactivity of the phenyl group with Fleming-Tamao methodology, to afford diol **186**. A brief overview of this oxidation, including the research carried out by Griffiths, is given below.

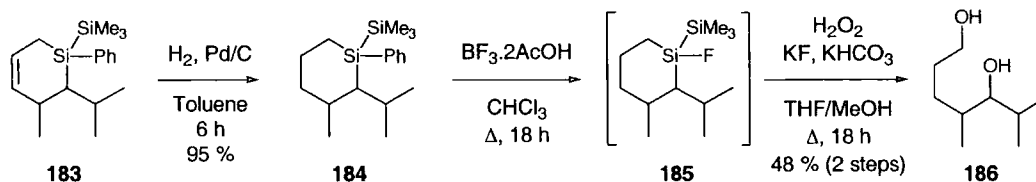

Scheme 127

5.1.2 Oxidation of Organosilicon Compounds

Tamao showed that organosilicon species bearing an electronegative substituent, such as fluoride or an alkoxy group, could be oxidised by peroxide reagents, Scheme 128.^{161, 162} The mechanism of this reaction is thought to proceed *via* the pentacoordinate ate complex **256**, formed by nucleophilic addition of peroxide, followed by a 1,2-Baeyer-Villiger-type migration to give the silyl ether **257** which affords the alcohol on hydrolysis.¹⁶³ Importantly, the migration has been shown to proceed with retention of stereochemistry at the carbon centre. Tamao has suggested that the mechanism actually involves a hexacoordinate dianionic intermediate **258** formed by addition of F⁻ and the peroxide. This explains the fact that the reaction only proceeds in the presence of KF.¹⁶⁴

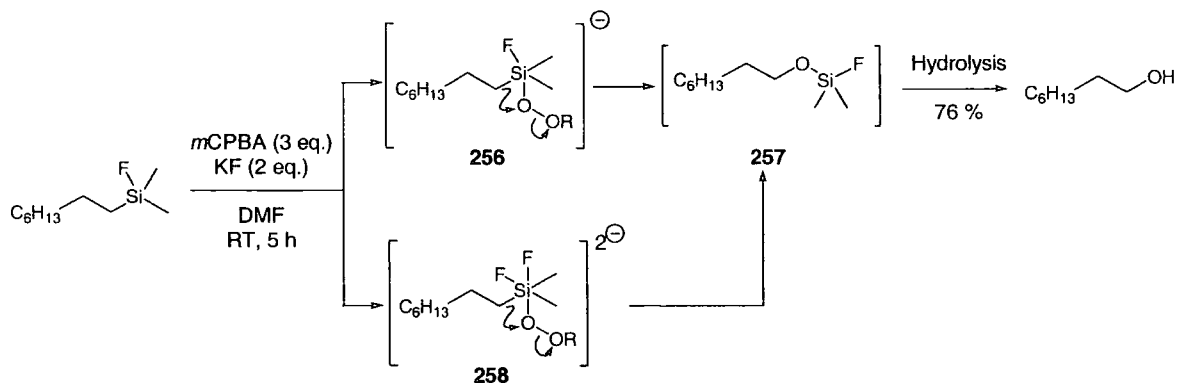

Scheme 128

The disadvantage of the Tamao oxidation is that organosilicon compounds bearing electronegative substituents are generally reactive and unstable. Fleming circumvented this problem by the development of a 2-step process commencing with stable aryl-substituted silanes, Scheme 129. On treatment with an electrophilic reagent, EX, such as $\text{BF}_3 \cdot 2\text{AcOH}$, HBF_4 , bromine or $\text{Hg}(\text{OAc})_2$, the phenylsilane **259** undergoes attack at the *ipso* position to leave a β -carbocation **260** stabilised by silicon (see Section 1.2.1.6, page 4). The aryl group is then displaced by nucleophilic attack at silicon by the counter ion of the electrophilic reagent to afford the activated silane **261**. Reaction of **261** with a peroxide gives the desired alcohol **262** in the same manner as described by Tamao.¹⁶⁵⁻¹⁶⁷ The example given in the scheme emphasises the fact that the reaction occurs with retention of stereochemistry.

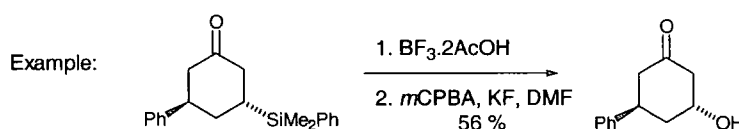
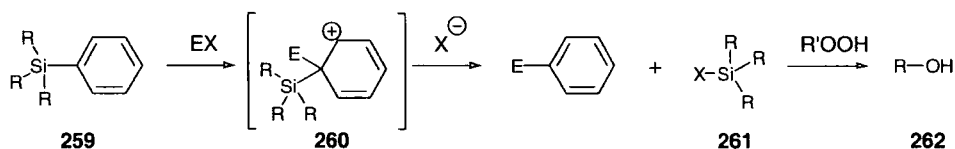

Scheme 129

As described in Section 1.6 (page 43) of Chapter 1, Griffiths' attempts to oxidise silacycles resulting from thermolysis and photolysis were unsuccessful due to complications arising from the Me_3SiO substituent. However, oxidation of a simple model substrate **263**, which lacked this group, using combined Fleming-Tamao techniques, followed by *in situ* acetylation, provided bisacetate **264** in an overall yield of 60%, Scheme 130.¹⁰

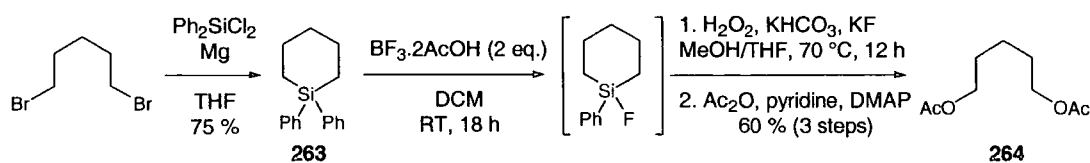

Scheme 130

With a viable oxidation procedure established, Griffiths successfully oxidised the hydrogenated silene-diene [4+2] cycloadduct **255**. Furthermore, it was demonstrated that the unsaturated silacycle **183** could be converted into the bishomoallylic alcohol **267** by exploiting the tendency of the allylsilane to form a β -carbocation **265** on treatment with the electrophilic reagent $\text{BF}_3 \cdot 2\text{AcOH}$, Scheme 131.

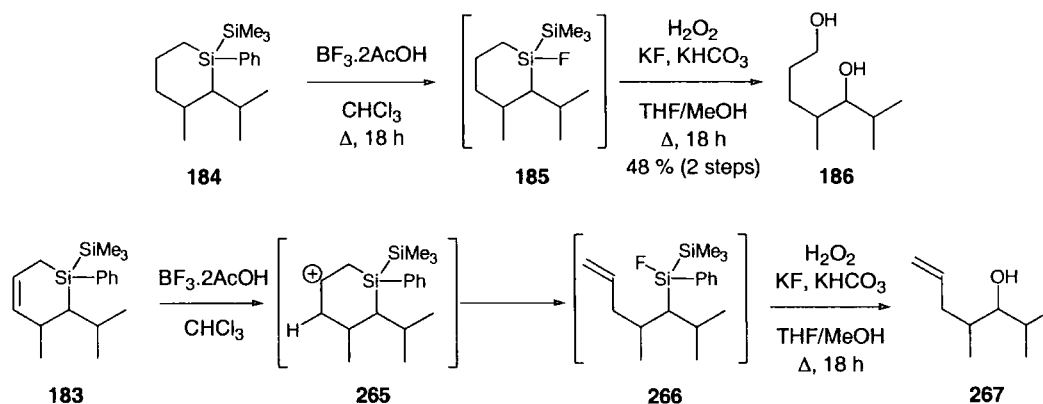

Scheme 131

These preliminary investigations showed that the silacycles resulting from the modified Peterson olefination of phenyl-substituted silyl alcohol precursors could be derivatised into two kinds of useful synthetic building blocks. However, the procedure was unoptimised, the stereochemistry of each compound was unknown and only one substrate and one diene had been studied.

5.2 Silacycles Derived from Various Dienes

5.2.1 1,3-Pentadiene

Initial studies concentrated on repeating the reactions carried out by Griffiths with a view to determining the stereochemistry of the silene-diene [4+2] cycloaddition. Hence, silene **238** was generated in the presence of 1,3-pentadiene using the novel method employing LiBr, Scheme 132. The 1,3-pentadiene used was the more affordable mixture of *cis*- and *trans*-isomers, but it was speculated that the use of 6 equivalents ensures that only the less hindered *trans* isomer takes part in the Diels-Alder reaction. ^1H NMR spectroscopy of the crude product mixture revealed the major product to be silacycle **183**, but also present were starting material **182** and silanes **227** and **244**, the formation of which was discussed in Section 4.2.1 (page 76). Silacycle **183** was isolated in 50 % yield* and GCMS showed it to be a mixture of 3 isomers, with a ratio of product peak integrals in the GC trace of 83 : 9 : 8 % . Although these minor isomers could be the result of [2+2] addition or ene reaction, the

* Reaction employing MeLi afforded **183** in a yield of 52 %.

similarity of the mass spectra suggested they were diastereoisomers. Also isolated in 5 % yield was a mixture of diastereoisomeric silene dimers **240** and/or **241** characterised by a GCMS trace showing peaks for the molecular ions at $m/z=468$. The formation of by-products **227**, **244**, **240** and/or **241** is typical for all of the reactions involving silene generation carried out during the research this thesis describes, so their occurrence will be assumed for the rest of this chapter.

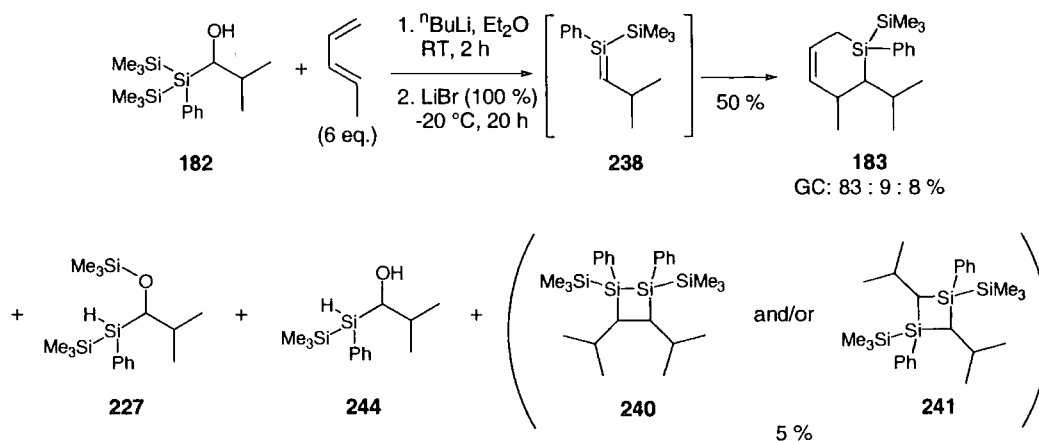

It was not possible to assign the stereochemistry of the major diastereoisomer of silacycle **183** by NOESY NMR experiments, so it was hoped that the reaction products from downstream chemistry would furnish the desired information. Unsaturated silacycle **183** was therefore converted into the bishomoallylic alcohol **267** using the Fleming-Tamao oxidation employed by Griffiths, Scheme 133. It was hoped that suitable functionalisation of **267** would provide a crystalline derivative, X-ray crystallography of which would reveal the stereochemistry. 4-Nitrobenzoyl esters are known to be crystalline in many cases so **267** was converted into ester **268**, but unfortunately the product was an oil.

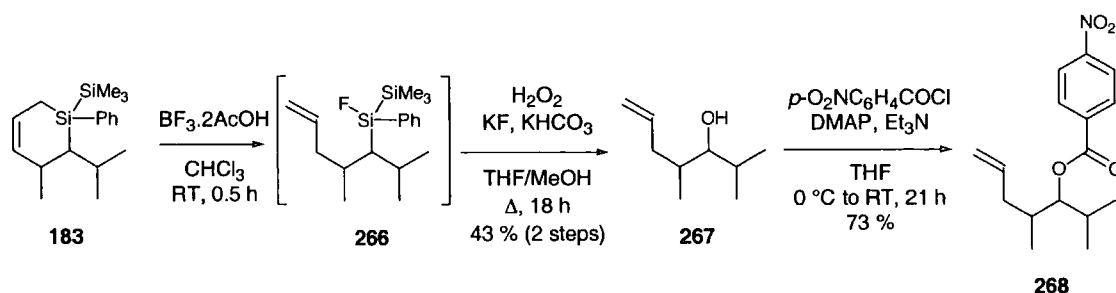

Subsequently, building on work carried out by Griffiths, silacycle **183** was hydrogenated and oxidised to afford diol **186** in excellent yield, Scheme 134. In an attempt to derive a crystalline compound, this was esterified with *p*-nitrobenzoyl chloride which yielded both the diester **269** and the monoester **270**. Unfortunately, neither of these products were crystalline.

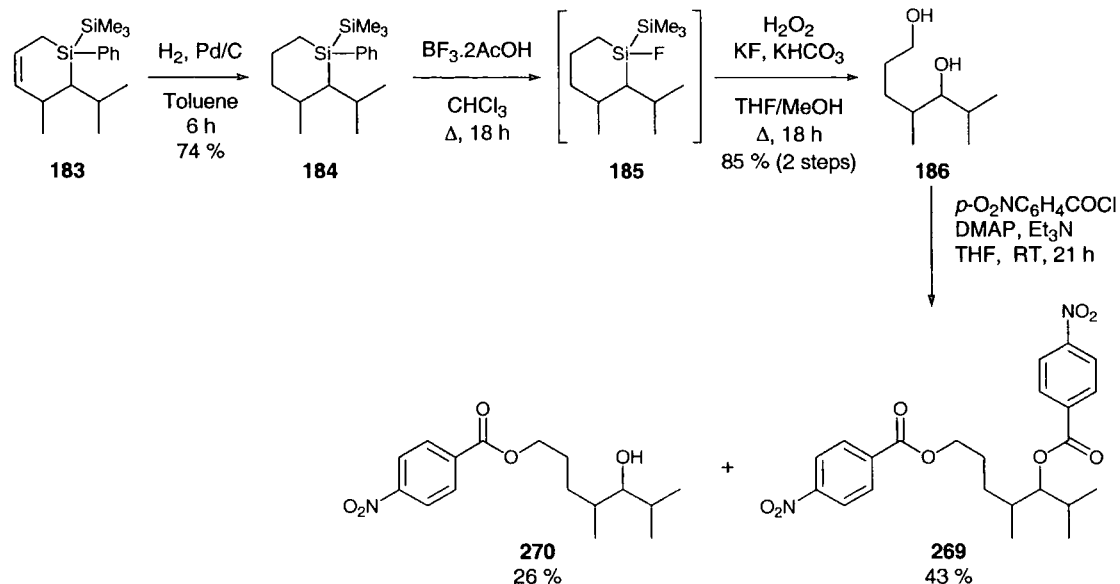

It was speculated that conversion of diol **186** into a cyclic derivative would allow facile deduction of the stereochemistry by NOESY NMR. The diol was therefore converted into lactone **271** by treatment with catalytic TPAP, using NMO as a co-oxidant, a method well documented in the literature, Scheme 135.¹⁶⁸⁻¹⁷⁰ This procedure gave lactone **271** as a 92 : 8 mixture of diastereoisomers, which were present at the silacycloadduct stage. NOESY experiments and comparison of the data for the major isomer of **271** with that of both isomers given in the literature suggested **271** was the *trans*-isomer, but this was not completely conclusive.^{171, 172}

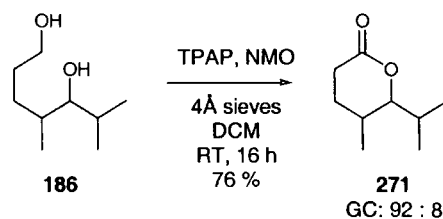

In order to know the stereochemistry of the major isomer of **271** unambiguously, the *cis*-lactone **276** was synthesised according to Helquist, Scheme 136.¹⁷² The key step of this procedure, which installs the desired stereochemistry, is the rhodium-catalysed hydrogenation of enone **274** which involves delivery of H₂ on one face of the molecule. The NMR and NOESY experiments of both lactones **276** and **271** were carried out under identical conditions and comparison of the data allowed the stereochemistry of **271** to be assigned as *trans*, Figure 9.

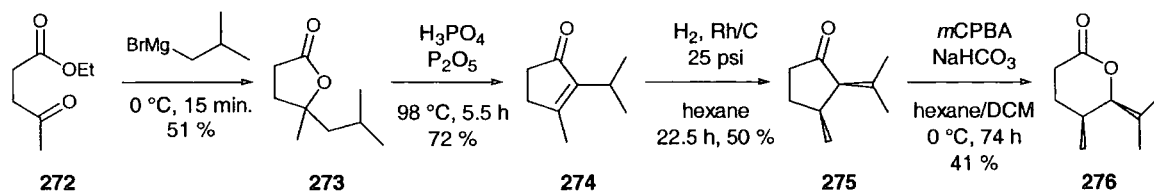

Scheme 136

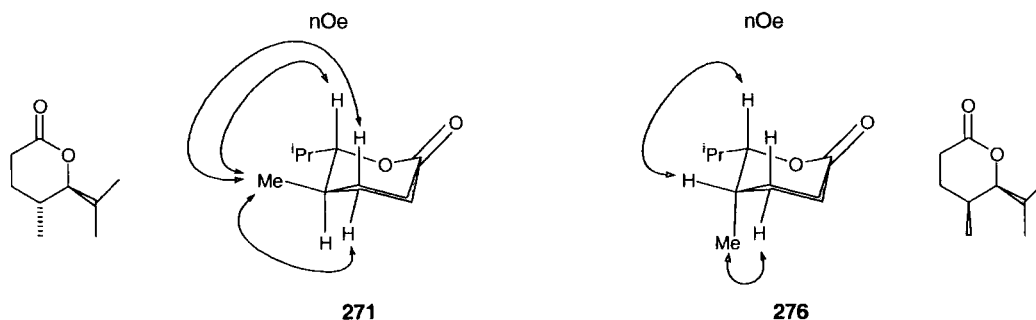
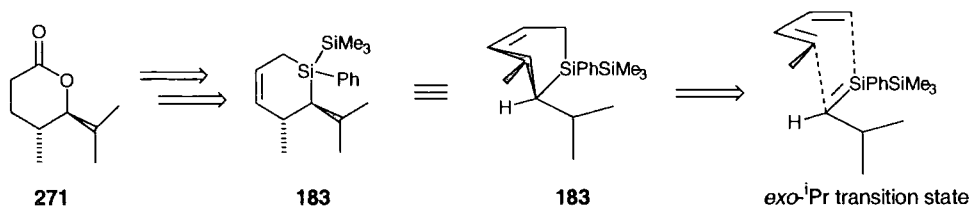

Figure 9

The stereochemical information obtained from the lactone allowed that of the silene-diene [4+2] cycloaddition to be determined as *exo* with respect to the isopropyl group, Scheme 137. This could be attributed to steric hindrance between the diene and the isopropyl group although, at this stage, the geometry of the silene, with respect to the Ph and TMS groups, remained unknown.



Scheme 137

5.2.2 2,3-Dimethylbutadiene

5.2.2.1 Silacycle Formation and Stereochemistry

Use of 2,3-dimethylbutadiene as a trapping agent during silene generation, using the LiBr method, yielded silacycle **239** as the major product in an inseparable mixture of isomers ($m/z=316$), with a ratio of product peak integrals in the GC trace of 73 : 15 : 12 %, Scheme 138. The isomer present in 15 % is hypothesised to be the diastereoisomer of **239**. The presence of olefinic peaks in the NMR spectrum (see Experimental, Chapter 7, for details) and the loss of fragments with $m/z=57$ and 81 in the GCMS trace implied that 12 % of the mixture was silyldiene **277**, the result of an ene reaction between 2,3-dimethylbutadiene and the silene. As discussed in Section 1.5.3.2 (page 32), ene reactions are a common occurrence when this diene is treated with silenes. Also detected in trace amounts was a fourth isomer tentatively identified as the [2+2] adduct **278**. An earlier, successful reaction

employing MeLi had given a similar mixture of isomers but with the different ratio of product peak integrals in the GC trace of 83 : 8 : 9 %. This mixture was carried through further manipulations, described below.

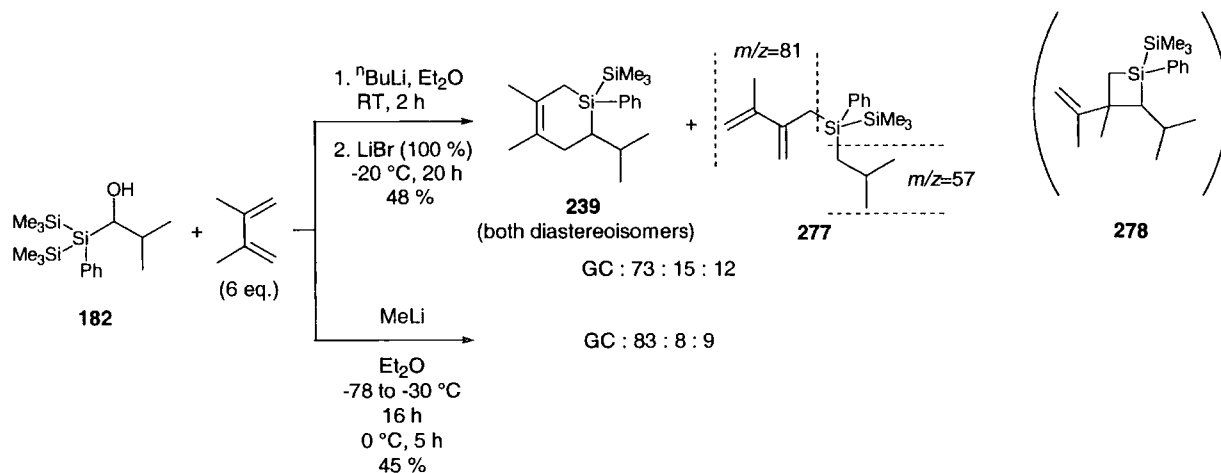

Scheme 138

The stereochemistry of the major isomer of **239** was determined by a NOESY experiment and consideration of the coupling constants; $J=11.0$ Hz implying coupling between two axial protons, one of which exhibits an $n\text{Oe}$ correlation to the phenyl group, Scheme 139. Since NMR experiments on stable silenes have proved there to be no rotation about a $\text{Si}=\text{C}$ double bond,²⁴ this stereochemistry must be the result of the formation of the *cis*-silene. This is a result of both the stereoselectivity of the elimination of Me_3SiOLi from silyllithium **243** (*syn* or *anti*) and the stereoselectivity of the TMS migration of oxyllithium **242**.

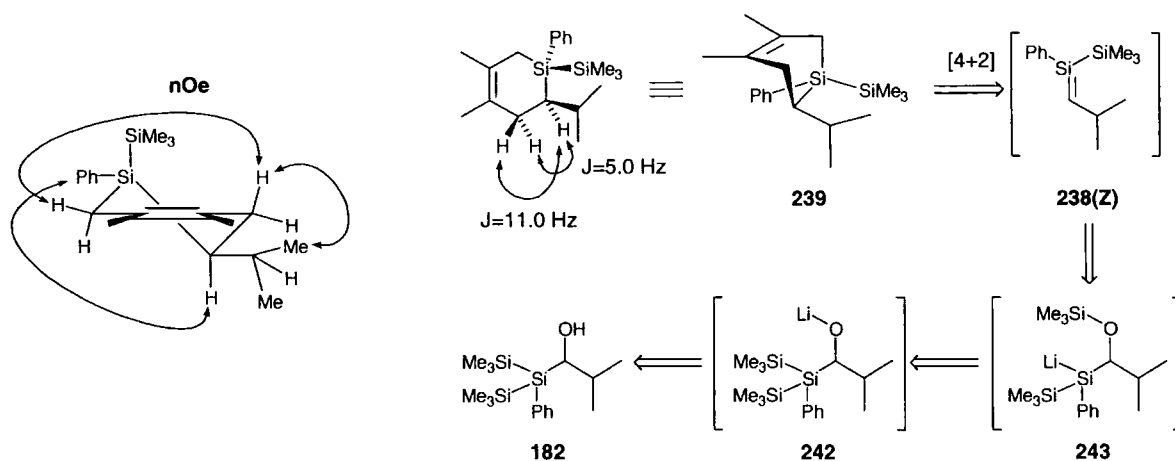

Scheme 139

The stereoselectivity can now be rationalised as arising in one of two ways, Scheme 140:

1. The oxanion **242** adopts the conformation **A** prior to TMS abstraction. Consideration of the A-values of the substituents ($A_{i\text{-Pr}}=9.25$, $A_{\text{Ph}}=11.71$, $A_{\text{TMS}}=10.50$),¹⁷³ for an indication of steric bulk, reveals this to be a higher energy conformation than **D** as the larger Ph and $i\text{Pr}$ groups are undergoing eclipsing

interactions. Nevertheless, the resulting silyl anion **243B** exists in solution long enough to rotate to the lower energy antiperiplanar conformation **C**, where the smaller TMS group is interacting with the ¹Pr group. *Anti*-elimination of this gives the *cis*-silene.

- The oxyanion **242** adopts the lower energy eclipsed conformation **D**. TMS abstraction gives the silyl anion **E** which could undergo elimination in a *syn*-fashion to afford the *cis*-silene. However, this *syn*-elimination is unlikely given the long life-time of the silyl anion **243** (it takes 18 h for complete elimination after the addition of LiBr) so a more feasible explanation is that rotation occurs to give a lower energy staggered conformation such as **F**. **F** is higher in energy than **C**, but it is speculated that the silyl anion is configurationally unstable and interconverts to diastereoisomer **C**. Evidence for the configurational instability of silyllithiums, such as **243**, has been reported by Kawakami, who showed that optically pure silyllithiums undergo racemisation even at low temperatures, Figure 10.¹⁷⁴ The graph in the figure shows the resulting e.e. after stirring the optically pure silyllithium at the given temperature for 1 h. Consequently, it is believed that stirring silyllithium **243** for 18 h at -30 °C results in an equilibrated mixture of diastereoisomers **C** and **F**. Again, elimination of Me₃SiOLi from **C** gives the *cis*-silene.

Overall, it is speculated that independent of which TMS group is abstracted by oxyanion **242**, equilibration between the resulting two diastereomeric silyllithiums **C** and **F** ensures the lower energy diastereoisomer **C** exists most in solution. *Anti*-elimination of Me₃SiOLi from this gives the *cis*-silene **238(Z)**.

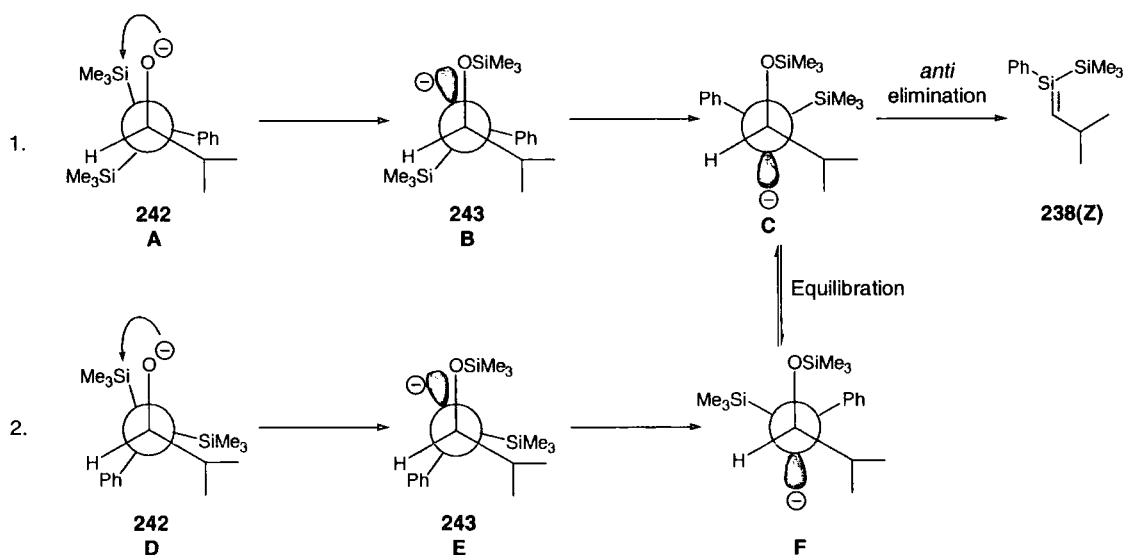

Scheme 140

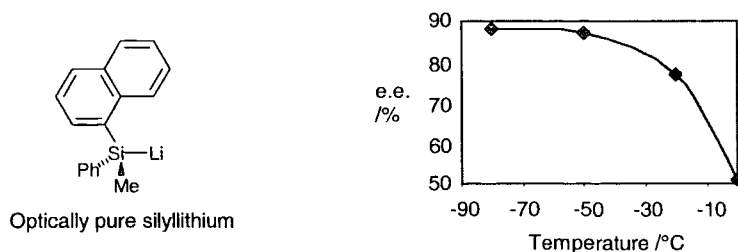
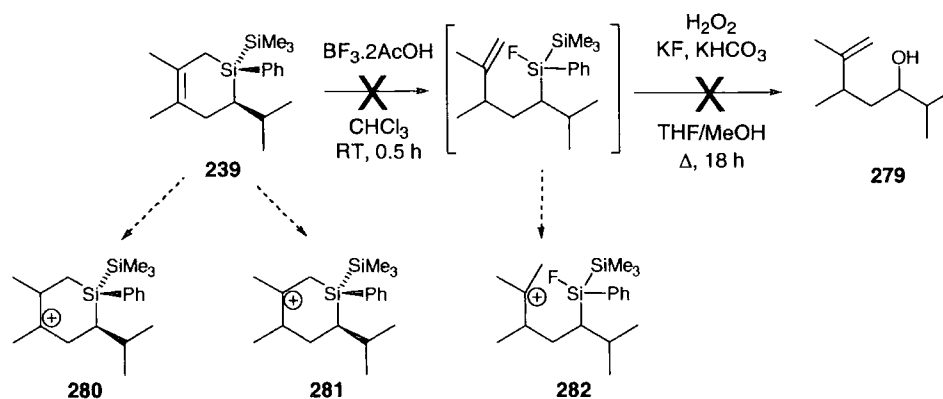

Figure 10

5.2.2.2 Silacycle Elaboration

Direct reaction of silacycle **239** under Fleming-Tamao conditions gave a mixture of decomposition products, from which no desired product **279** could be extracted. This is attributed to the presence of several tertiary centres in **239**, and its derivatives, which can form stable carbocations such as **280-282** and lead to all manner of products, Scheme 141.



Scheme 141

Hydrogenation of the mixture of **239** and **277** using Pd/C catalyst was unsuccessful due to the steric hindrance of the quaternary alkene. Several sets of reaction conditions were therefore screened and, apart from some reduction of the phenyl group, success was attained when a platinum dioxide catalyst was used in ethanol, Scheme 142.¹⁷⁵⁻¹⁷⁷ Under these conditions, however, an inseparable mixture of saturated silanes **283-287** was obtained. As is described below, the composition of this mixture was verified by excision of the silyl unit and benzoylation of the resulting alcohols and the stereochemistries were determined by NOESY experiments on the lactones formed from the diols. A mixture of 4 diastereoisomers of the saturated silacycle was obtained because some scrambling of stereochemical configuration occurred at the β -silyl centre. Such scrambling is well documented in the literature and is ascribed to migration of the double bond prior to reduction as shown in the scheme.¹⁷⁷⁻¹⁷⁹ *Cis*-hydrogenation of **239** occurred on the face opposite the bulkiest substituent, the phenyl group, as did that of the opposite diastereoisomer. The latter result could be deduced because Fleming-Tamao excision of the silyl unit resulted in a mixture of 4 diastereoisomers.

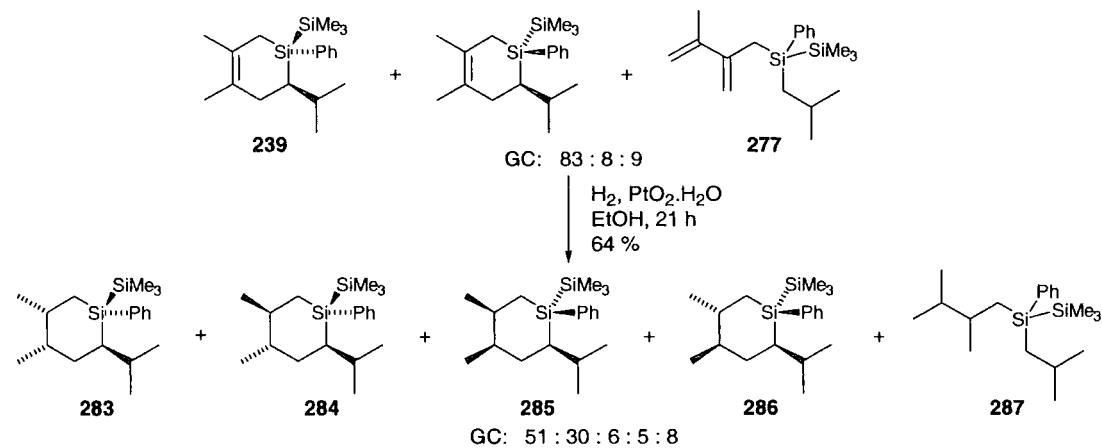

Mechanism of racemisation:

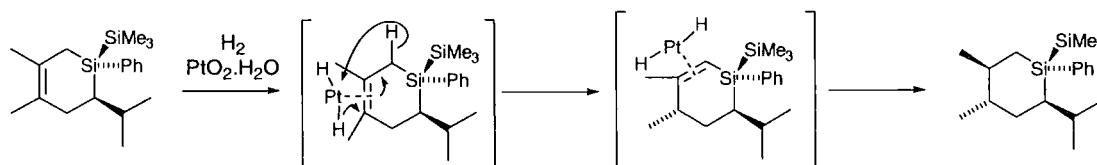

Scheme 142

As mentioned above, in order to fully characterise the mixture of saturated silanes **283-287**, in terms of composition and stereochemistry, several sets of experiments were carried out. Firstly, Fleming-Tamao oxidation of mixture **283-287** produced a crude mixture of all possible alcohols **288-293**, Scheme 143. This mixture was divided and half was chromatographed to afford pure diol **288** and inseparable diol mixture **289-291** in 39 % and 24 % yield respectively. The remainder of the crude mixture was treated with benzoyl chloride to trap the volatile diols **292** and **293** and amass evidence for the existence of ene product **277**. Identification of all of the benzoylated products in the GCMS trace of this mixture was aided by synthesis of the benzoyl esters from purified diol **288** and diol mixture **289-291**. This produced both the mono- and diesters (see Experimental Section (page 145), Chapter 7 for details) which were also formed from the crude mixture. Figure 11 shows the GC trace of the benzoylated crude alcohol mixture with all peaks identified.

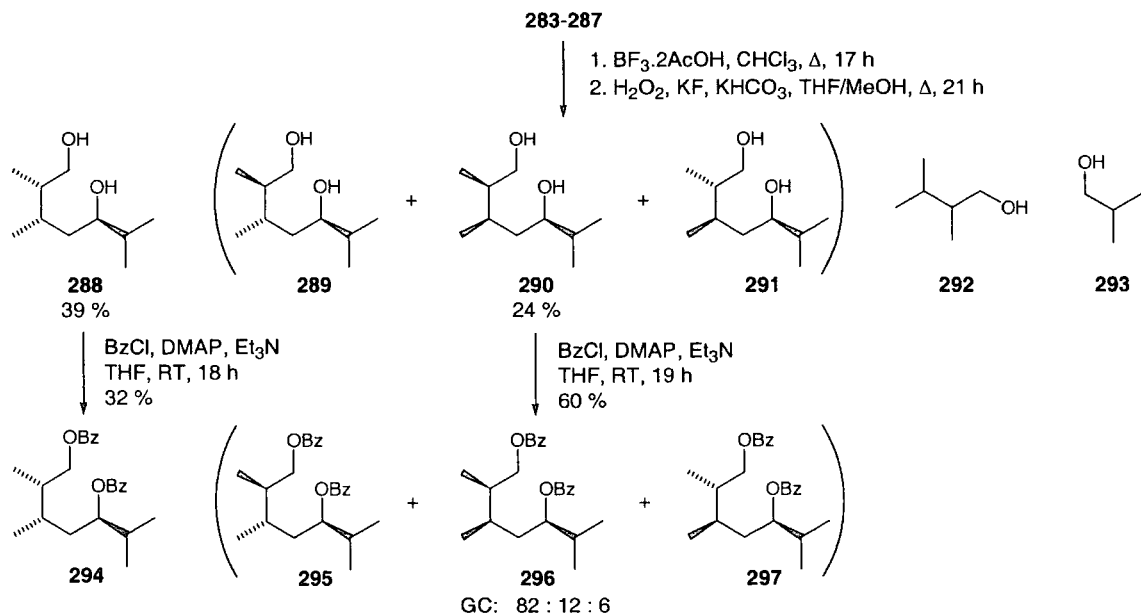

Scheme 143

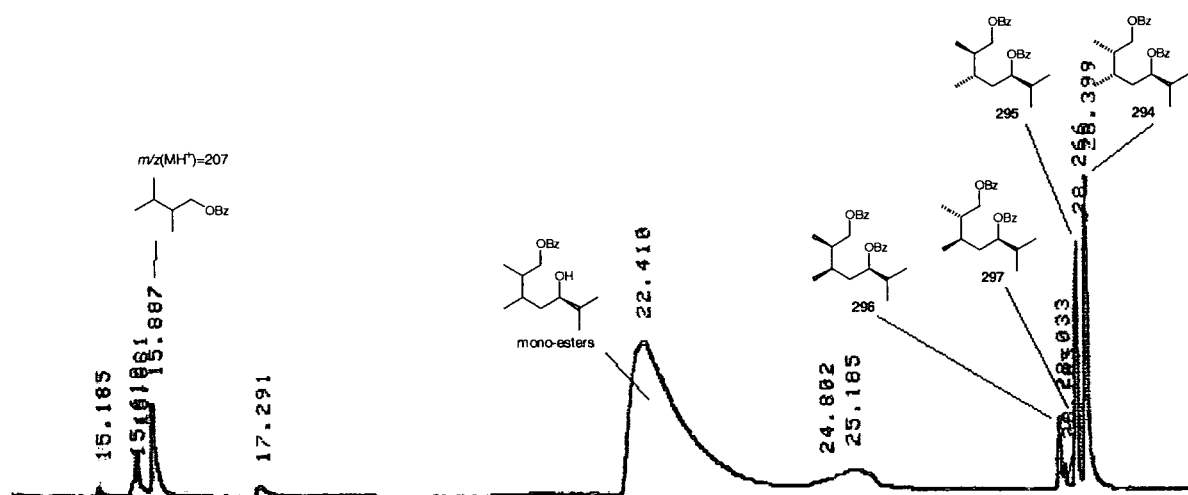
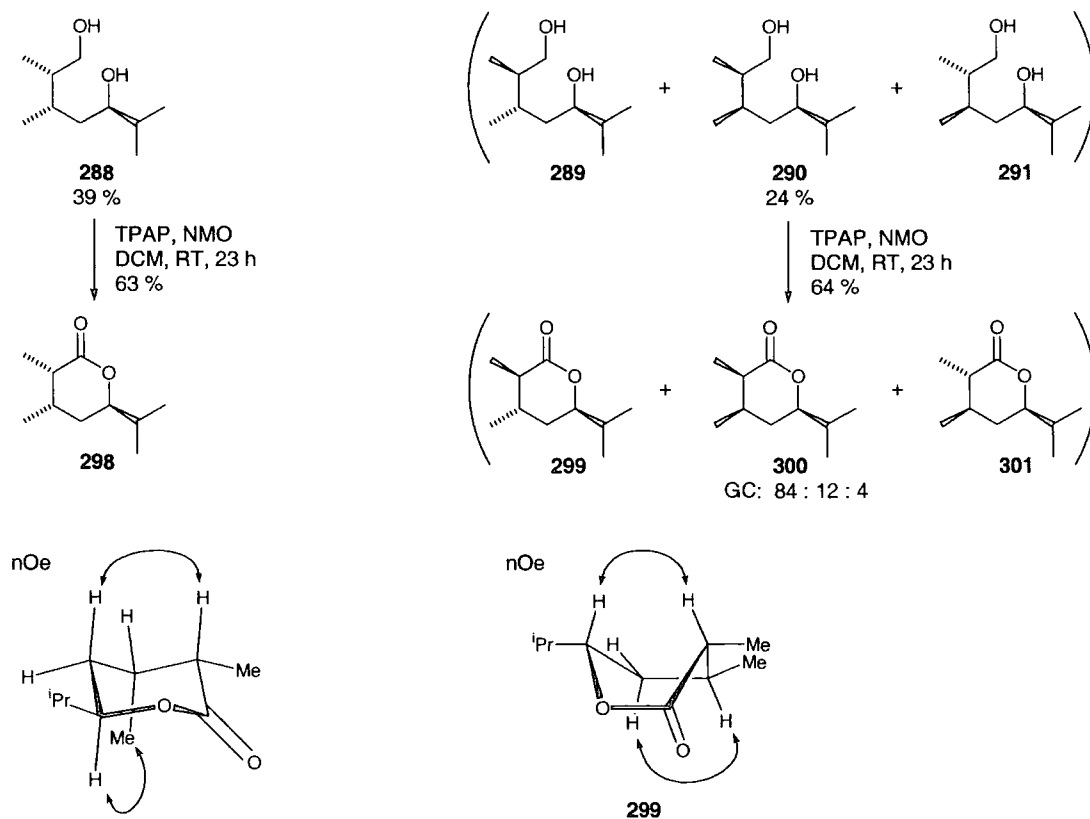

Figure 11

The stereochemistry of all the products described above was not actually known until lactones **298-301** were synthesised and NOESY experiments carried out, Scheme 144.



Scheme 144

5.2.3 Isoprene

Silene generation in the presence of isoprene gave a mixture of products including silacycle regioisomers **302** and **303** and ene product **304** with a ratio of product peak integrals in the GC trace of 72 : 16 : 12 %, Scheme 145.* The latter product was identified by olefinic peaks in the NMR spectrum (see Experimental, Chapter 7, for details) and the loss of fragments with $m/z=57$ and 67 in the GCMS. The formation of both silacycle regioisomers with isoprene is expected, as discussed in Section 1.5.3.3 (page 35). Although it appeared that only one diastereoisomer of each regioisomer had been formed, later elaboration of the silacycles confirmed that a mixture of diastereoisomers was present, but that the GC retention times were identical.

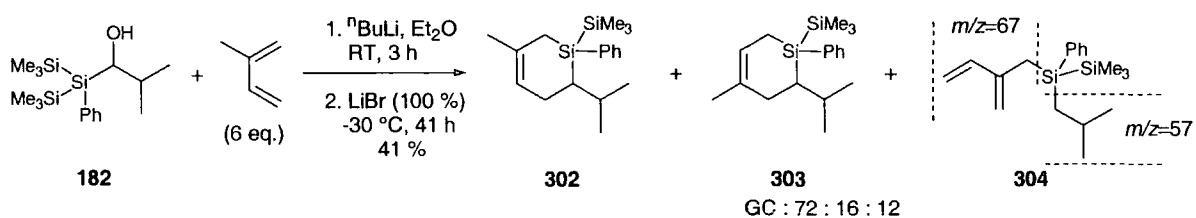

Scheme 145

* Reaction employing MeLi gave the mixture in 27 % yield and a ratio of 84 : 11 : 5 %.

It was speculated that the regioisomeric ratio would be improved if the polarity of the intermediate silene was increased because this would increase the HOMO-LUMO interaction by exaggerating the difference in orbital coefficients, between silicon and carbon, of the silene. To test this, methoxyphenyl-substituted silene **305** was generated from precursor **237** in the presence of isoprene. However, the mixture of silanes **306-308** was formed in comparable ratio to the phenyl-substituted analogues, Scheme 146.

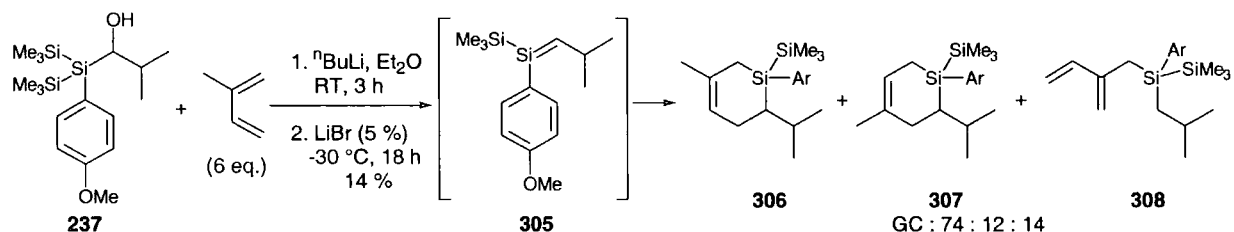

Scheme 146

Hydrogenation of silane mixture **302-304** followed by Fleming-Tamao oxidation and lactonisation gave only 3 isomeric lactones **316-318**, Scheme 147, whereas a GCMS trace of the saturated silane mixture **309-312** revealed 4 diastereoisomers. This proved that more than one diastereoisomer of **302** or **303** (differing at the silicon centre) must have been present prior to hydrogenation. Interestingly, it seems that only the stereochemistry of the chiral centre β to silicon was scrambled during hydrogenation, as only one diastereoisomer of lactone **318** was detected. The stereochemistry of **318** was deduced by comparison with the literature data,¹⁸⁰ and that of minor isomer **317** by the nOe correlation shown.

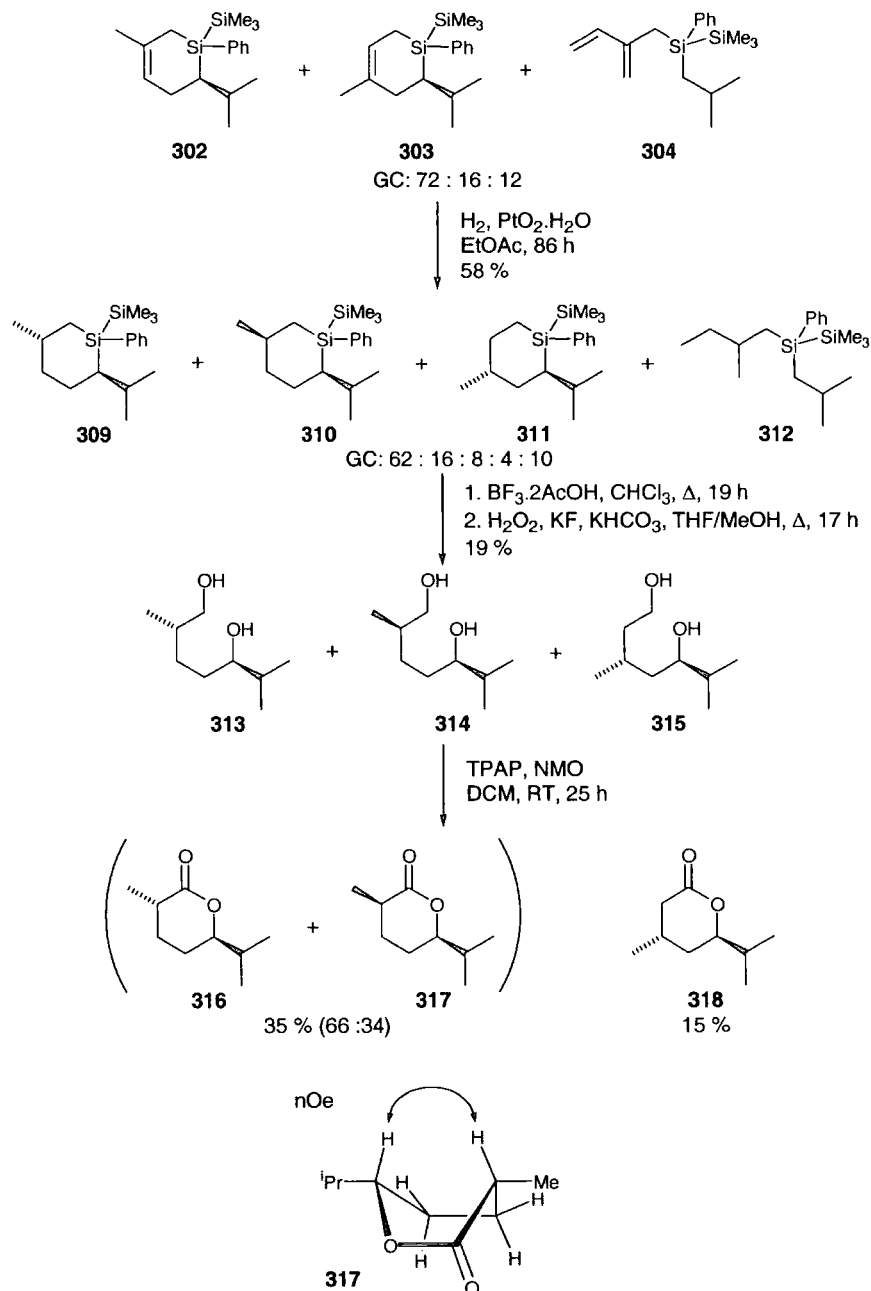

Scheme 147

5.2.4 2-Methyl-1,3-pentadiene

Silene generation in the presence of 2-methyl-1,3-pentadiene gave a mixture of diastereoisomers of silacycle **319**, Scheme 148.* By analogy to reactions using 1,3-pentadiene and 2,3-dimethylbutadiene and by the identification of the products from silacycle elaboration, the stereochemistry of the major isomer **319** was determined as that shown in the scheme. Interestingly, only trace amounts of ene product could be detected, an observation also made with 1,3-pentadiene, suggesting that dienes with terminal substitution are much more predisposed to [4+2] cycloaddition than ene reaction.

* Reaction employing MeLi gave the mixture in 9 % yield and a ratio of 94 : 5 : 1 %.

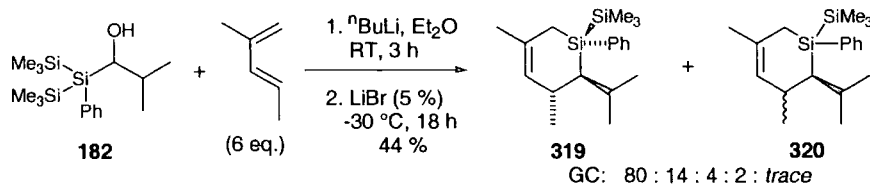

Scheme 148

Hydrogenation of the silacycle mixture caused extensive stereochemical scrambling of the carbon centre β to silicon, almost in the ratio of 1 : 1, Scheme 149. This is attributed to conflicting steric requirements between all of the silacycle substituents. Fleming-Tamao oxidation afforded a mixture of diols from which **324** could be separated. Treatment of this diol with TPAP and NMO afforded the lactone **327**. Consideration of the NMR coupling constants and a NOESY experiment allowed the stereochemistry to be determined as shown in the scheme. Lactone **327** is actually a natural product; a sex pheromone isolated from *macrocentrus grandii*, a larval parasitoid of the European corn borer (*ostrinia nubilalis*).¹⁸¹
¹⁸² The latter is an agricultural pest and it has been speculated in the literature that populations could be controlled by attracting the larval parasitoid to the crops. As a result, the lactone sex pheromone has been an important synthetic target.¹⁸³

NOESY of the major lactone **328** formed from diol mixture **325-326** was inconclusive, but analysis of the coupling constants, depicted in the scheme, implied no axial relationships between the protons shown suggesting the α -methyl group occupies the axial position.

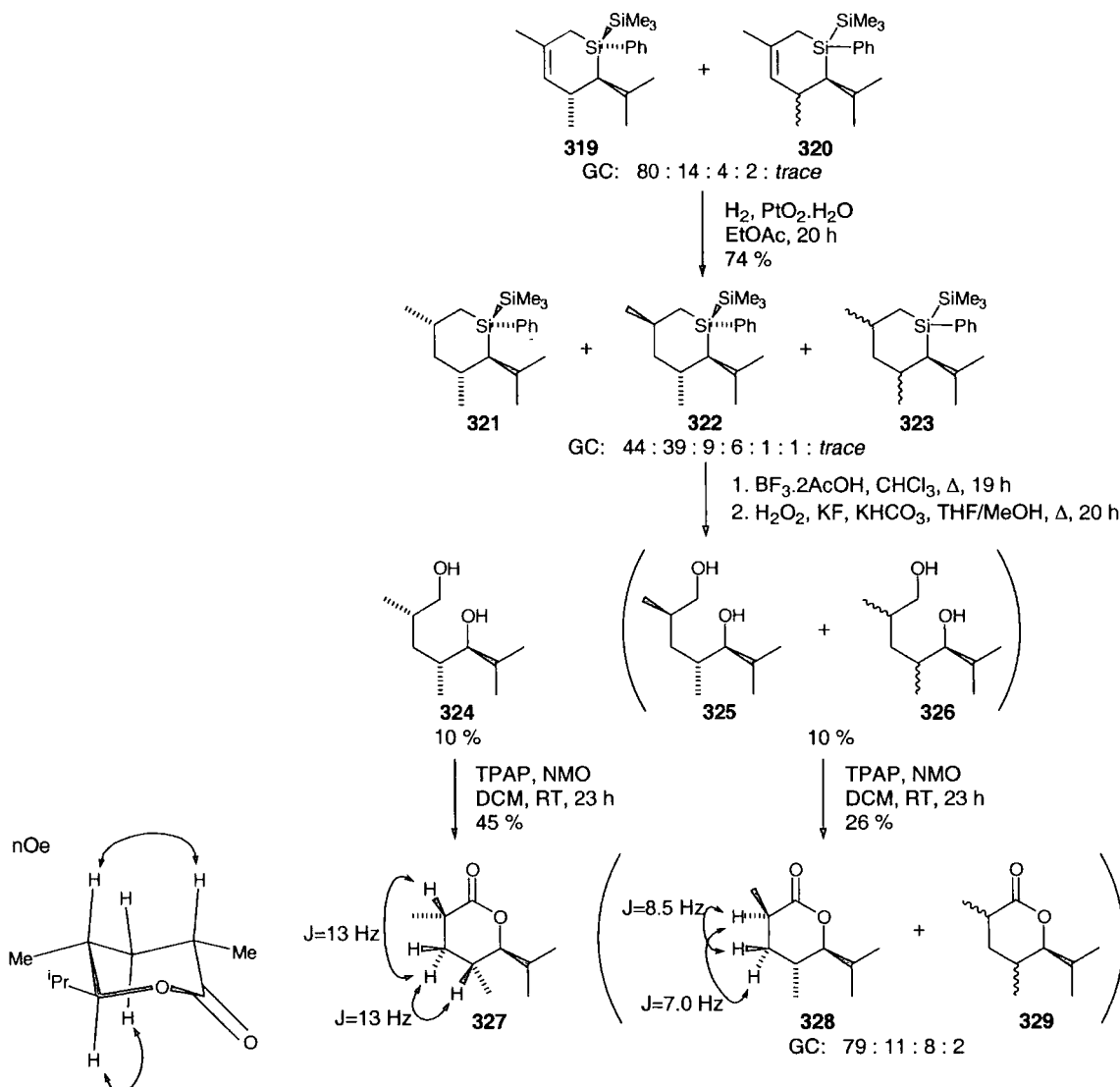

Scheme 149

5.2.5 3-Methyl-1,3-pentadiene

In a similar fashion to the above dienes, silene trapping with 3-methyl-1,3-pentadiene produced one major silacycle diastereoisomer **330** and 3 minor ones **331**, Scheme 150. As above, since this is a terminally substituted diene, only trace amounts of ene product were detected.

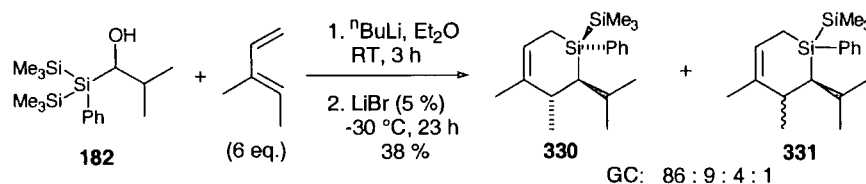

Scheme 150

These silacycles **330-331**, with methyl-substitution in the adjacent 3- and 4- positions, resisted all attempts to hydrogenate the double bond using Pt/C, PtO₂ in ethanol, ethyl acetate and acetic acid at atmospheric and high pressure,¹⁷⁵⁻¹⁷⁷ and the use of di-imide in a

transfer hydrogenation.¹⁸⁴ Finally, use of the homogeneous iridium catalyst, $\text{Ir}(\text{P-c-Hx}_3)(\text{cod})\text{pyr.PF}_6$, developed by Crabtree and known to be effective for substituted double bonds, produced the saturated silacycles **332-334** although in only 35 % yield, Scheme 151.^{178, 185-187} Literature examples suggest this catalyst should act with high stereoselectivity, but in this case both diastereoisomers **332** and **333** were produced. In contrast to hydrogenations of earlier silacycles using PtO_2 , the major isomer **332** results from hydrogenation on the same face as the phenyl group, perhaps as a result of a directing effect. The stereochemistries were determined in the usual manner by conversion into the lactones **338** and **339** on which NOESY experiments were performed, revealing the nOe correlations depicted in the scheme.

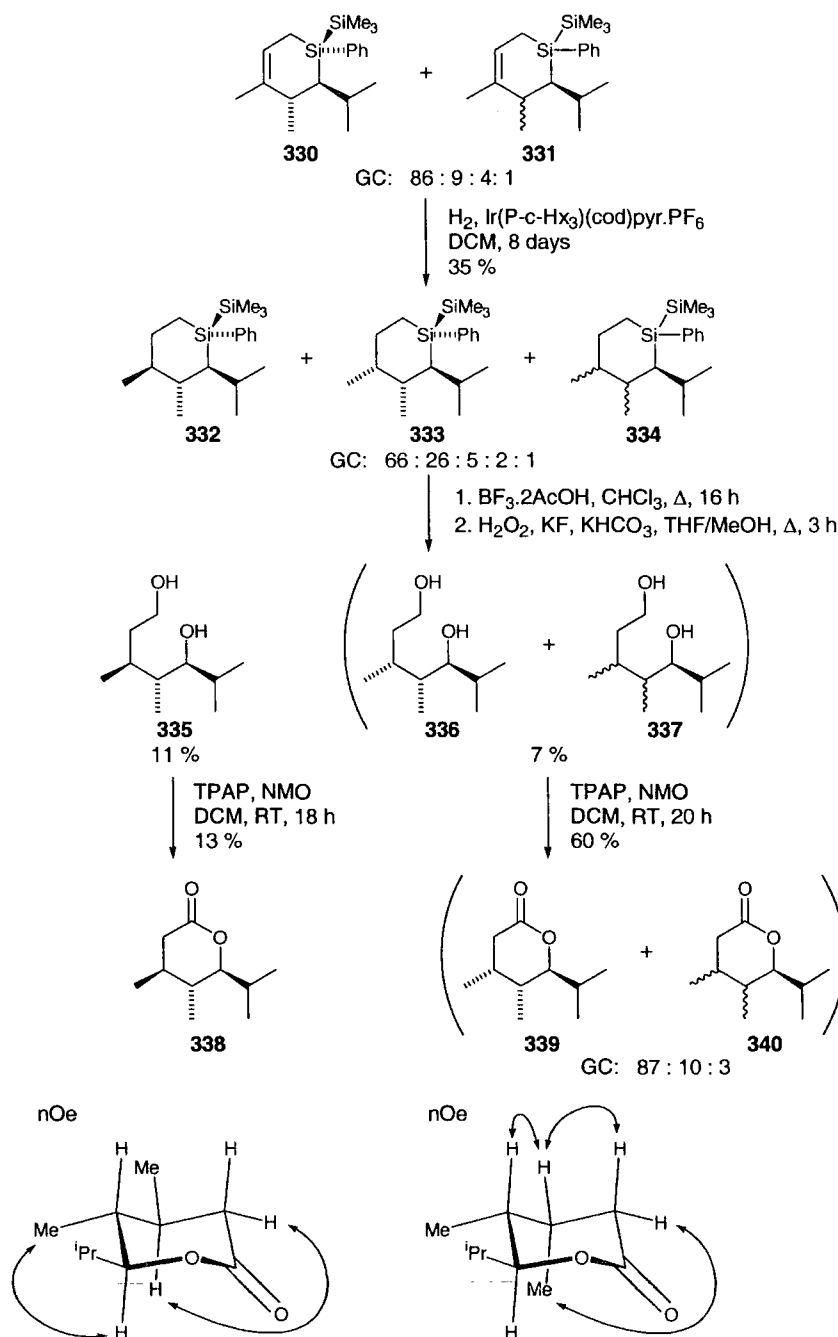

Scheme 151

5.2.6 Anomalous Diene Trapping Experiments

5.2.6.1 1-Methoxy-1,3-butadiene

Silene generation in the presence of the functionalised diene, 1-methoxy-1,3-butadiene, using the original method employing MeLi afforded silyldiene **342** in 8 % yield, Scheme 152. Also isolated was the starting silyl alcohol **182** (48 %) and silane **244** (9 %) which are the result of incomplete conversion and again demonstrate the unreliability of the reaction using MeLi (see Section 4.2, page 77). It is speculated that silyldiene **342** was formed as a result of elimination of MeOH from the intermediate [4+2] cycloadduct **341** during aqueous work-up, as shown in the scheme. The protons of the double bond formed in this elimination show a coupling constant of $J=15$ Hz in the ^1H NMR spectrum which indicates a *trans*-relationship. For this geometry to arise, the intermediate silacycle must have borne the *i*Pr and Me groups in the *trans*-relationship as depicted in the scheme. This is in agreement with the *exo*-transition state proven for the [4+2] cycloaddition with other dienes.

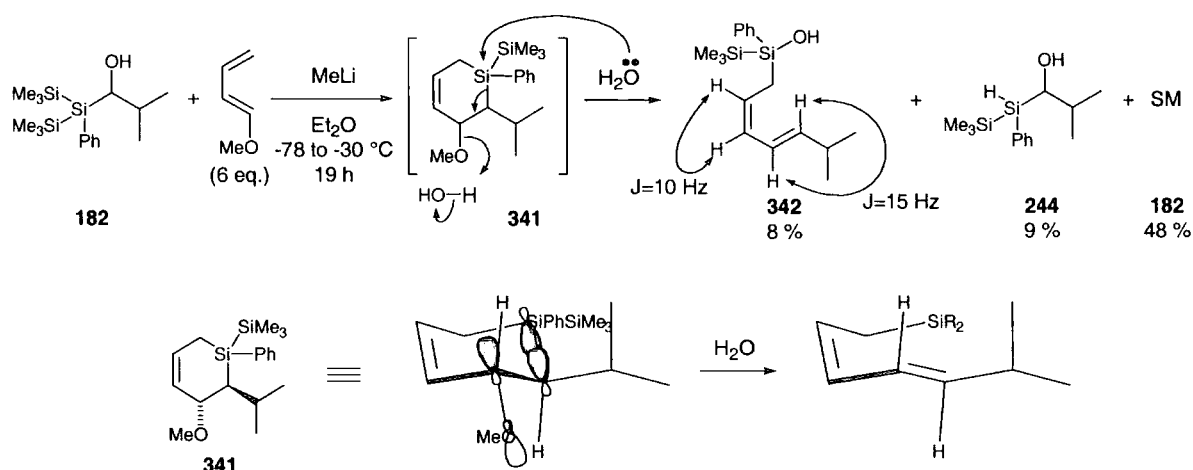

Scheme 152

5.2.6.2 Cyclohexadiene

Cyclohexadiene largely failed as a silene trapping agent with only a trace of the desired product **343** detectable by GCMS ($m/z(M^+)=314$). Instead, silene dimers **240** and/or **241** were detected along with unreacted starting material and silane **227**, Scheme 153. This result parallels that obtained by Griffiths (see Section 4.1, page 76) and also that obtained by Auner (see Section 1.5.3.4, page 36).^{10, 90, 91} As described earlier, it is speculated that [4+2] cycloaddition of this diene is hindered by the allylic protons as depicted in the scheme.

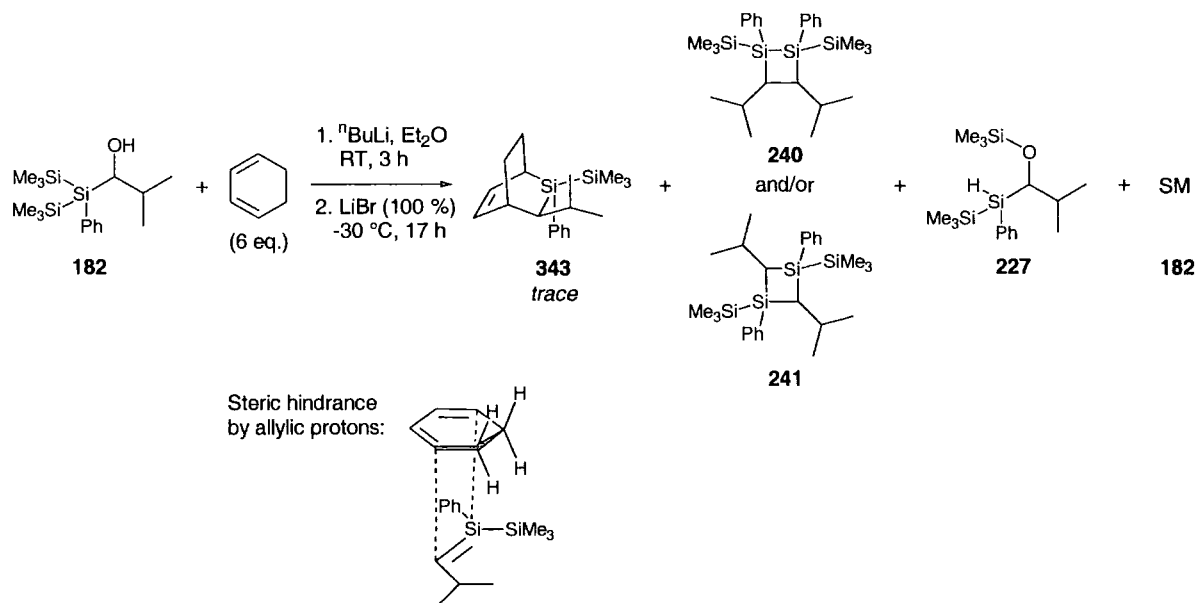

Scheme 153

5.2.6.3 1,6-Dimethoxy-*trans-trans*-2,4-hexadiene

A silene trapping experiment incorporating a 1,4-disubstituted diene was desirable for two reasons; to further demonstrate the versatility of the method and to provide evidence that the [4+2] cycloaddition is concerted. The latter would be shown if the stereocentres arising from the diene were conserved as in **344**, Scheme 154. However, if the reaction involved an ionic or radical intermediate such as **345**, which existed long enough for bond rotations to occur, then the stereocentres would be scrambled as in **346**.

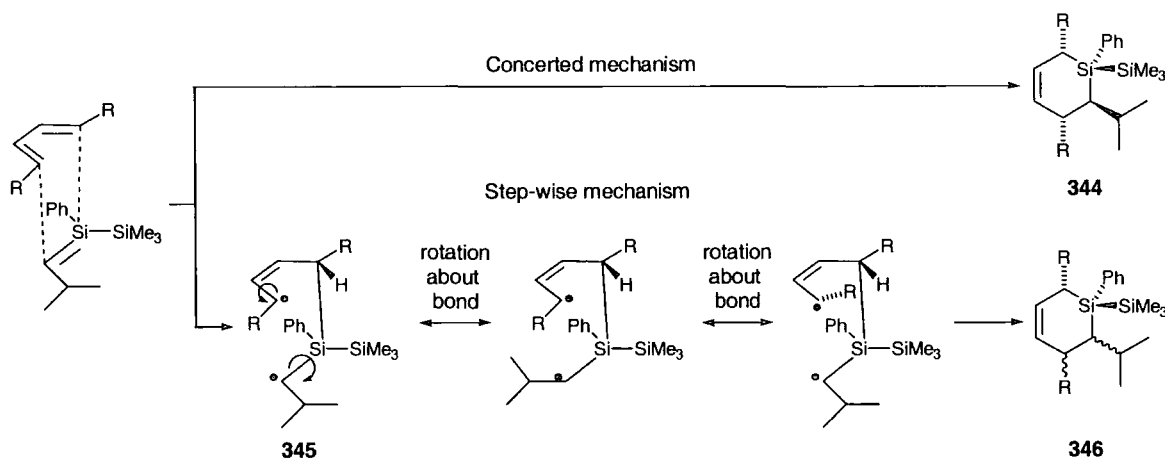

Scheme 154

Trans, trans-2,4-hexadiene was not commercially available so 1,6-dimethoxy-*trans-trans*-2,4-hexadiene **349** was synthesised. Initial failed attempts involved reduction of dimethyl-*trans, trans*-2,4-hexadienoate. A search of the literature revealed diol **348** could be synthesised by reduction of the dialkynediol **347** with Red-Al. Deprotonation of this followed by reaction with MeI afforded the desired diene **349**, Scheme 155.¹⁸⁸⁻¹⁹⁰



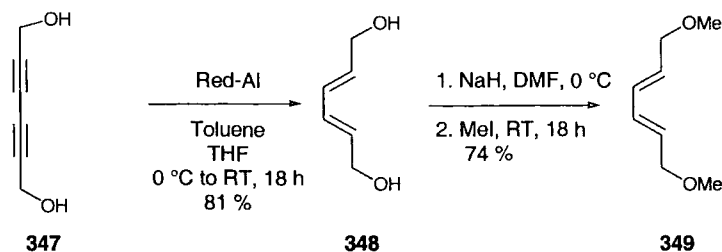

Scheme 155

Attempts to generate silene **238** in the presence of this diene failed and only silane **227** was isolated on work-up indicating no elimination of Me_3OLi had taken place, Scheme 156. This is attributed to competitive coordination of LiBr by the less hindered methoxy groups of the diene in an analogous manner to when THF is used as solvent. Future research would involve the synthesis and use of a non-coordinating 1,4-substituted diene, but time constraints precluded such work.

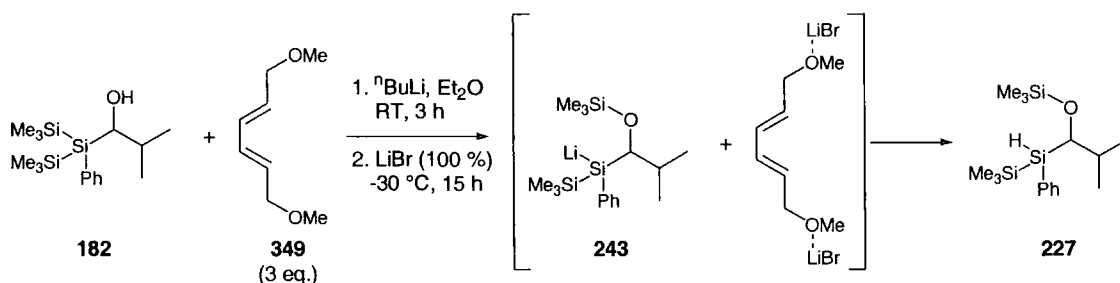

Scheme 156

5.2.7 Summary and Conclusion

Table 17 summarises successful silacycle syntheses and elaborations to form lactones. It can be concluded that open chain alkyl-substituted dienes react well with the silene generated by the modified Peterson olefination and with good diastereoselectivity. The diastereoisomers depicted in the table are the major ones of any mixtures obtained, the ratio of which is given below. It should be noted that the yields for Fleming-Tamao oxidation ([O]) of the last 3 entries were low due to the formation of polymeric material during treatment with hydrogen peroxide. These yields could not be improved despite the use of lower temperatures and/or shorter reaction times and the reaction is discussed further in the next section.





Diene	Silacycle	H ₂	[O]	Lactones
	 183 50 % (83 : 9 : 8)	74 %	85 %	 271 76 % (92 : 8)
	 239 48 % (83 : 8 : 9) + ene product 277	64 %	39 %, 24 %	 298 63 % +  299 64 % (84 : 12 : 4)
	 302 +  303 + ene product 304 41 % (72 : 16 : 12)	58 %	19 %	 316 35 % (66 : 34) +  318 15 %
	 319 44 % (80 : 14 : 4 : 2 : trace)	74 %	10 %, 10 %	 327 45 % +  328 26 % (79 : 11 : 8 : 2)
	 330 38 % (86 : 9 : 4 : 1)	35 %	11 %, 7 %	 338 13 % +  339 60 % (87 : 10 : 3)

Table 17

5.3 Silacycles Derived from Various Silyl Alcohols

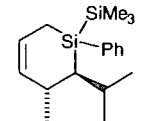
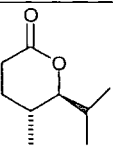
5.3.1 Hydrogenation Followed by Oxidation

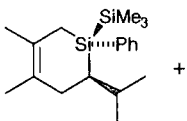
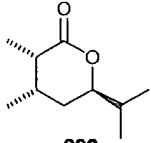
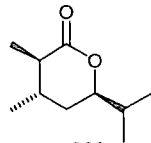
The research described in the previous section involved the screening of various dienes for their reactivity with the ⁱPr-substituted silene in order to establish the versatility of the reaction as a novel synthetic method. To further demonstrate the scope of this method, it was also necessary to screen various alkyl-substituted silenes **177**, accessed from their corresponding silene precursors, silyl alcohols **176**, Scheme 157, the synthesis of which was described in Chapter 3. Various silyl alcohols **176** were therefore treated with ⁿBuLi then LiBr in the presence of 1,3-pentadiene and the resulting silacycles hydrogenated, oxidised and lactonised in the same manner as previously.

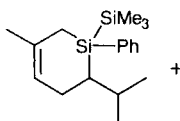
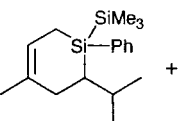
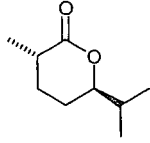
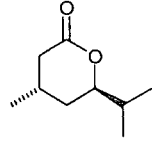
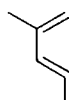
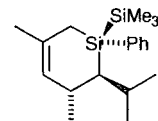
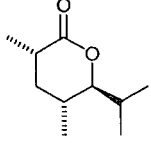
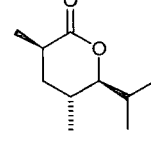
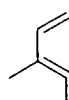
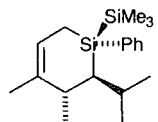
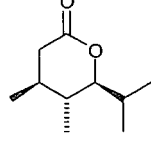
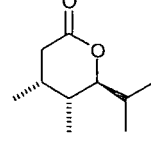
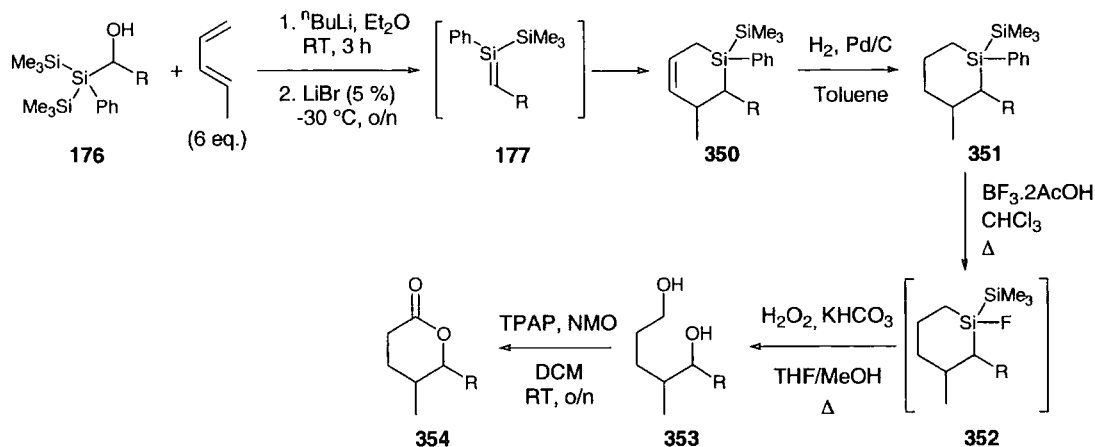

Scheme 157

Table 18 gives the results of several experiments. Entries 1 and 2 parallel the reaction using the original silyl alcohol **182** (entry 3) in that the major diastereoisomer of silacycle, and hence lactone, formed is the *trans*-isomer. The use of *t*-Bu-substituted silyl alcohol **232** (entry 4), however, produced the *cis*-substituted silacycle, the stereochemistry of which was determined unambiguously by elaboration to the lactone and comparison of the NMR spectra with the literature data and by a NOESY experiment. This stereoselectivity is explained below as the result of formation of the *trans*-silene.

Entry	Silyl alcohol	Silacycles	H_2	[O]	Lactones	NOESY	Ref.
1		 355 28 % (89 : 7 : 4)	90 %	56 %	 358 56 % (89 : 11)	Inconclusive	191
2		 359 12 % (81 : 12 : 7)	34 %	16 %	 362 29 % (72 : 28)		-
3		 183 50 % (83 : 9 : 8)	74 %	85 %	 271 76 % (92 : 8)	(see Section 5.2.1, page 89)	-
4		 363 35 % (85 : 5 : 5)	87 %*	21 %	 366 36 % (87 : 13)		192

*Pd/C was unsuccessful on this hindered silacycle, so the more reactive PtO_2 was used.

Table 18

5.3.1.1 Stereochemistry of the ^tBu-Substituted Silacycle **363**

The stereochemistry of the major diastereoisomer of the ^tBu-substituted silacycle **363** is a result of the ^tBu substituent occupying the *endo*-position during the [4+2] cycloaddition as depicted in Equation 1 of Scheme 158. Since this contradicts any steric arguments, it must be a result of secondary orbital interactions between the phenyl group of the *trans*-silene **367(E)** and the diene. However, this is the opposite silene geometry to that generated from all other alkyl-varied silyl alcohols. In Section 5.2.2.1 (page 90), an explanation was given as to why the *cis*-silene **238(Z)** was generated from ⁱPr-substituted silyl alcohol **182**. This is repeated in Equation 2 of Scheme 158, below, and states that silyl anion **243** is configurationally unstable and so equilibrates to give predominantly the lower energy diastereoisomer **243C**. *Anti*-elimination of Me₃SiOLi from this produces the *cis*-silene. In the case of the ^tBu-substituted silyl alcohol **232**, however, it is suggested that the resulting silyl anion is configurationally stable and cannot undergo equilibration, Equation 3, Scheme 158. This is because the extremely bulky ^tBu substituent prevents the passage of the Ph or TMS groups (A values: A_{^tBu}=20.00, A_{Ph}=11.71, A_{TMS}=10.5), something which was not a problem with the ⁱPr-substituted silyl anion (A_{ⁱPr}=9.25).¹⁷³ Now, the stereochemistry depends only on which TMS group is abstracted by the oxanion **368**. It is speculated that the less sterically demanding TMS group occupies the eclipsing position with the ^tBu group during this process **368A**. The resulting silyl anion **369B** can rotate past the ^tBu group to give the antiperiplanar conformation **369C**, from which elimination of Me₃SiOLi produces the *trans*-silene **367(E)**.

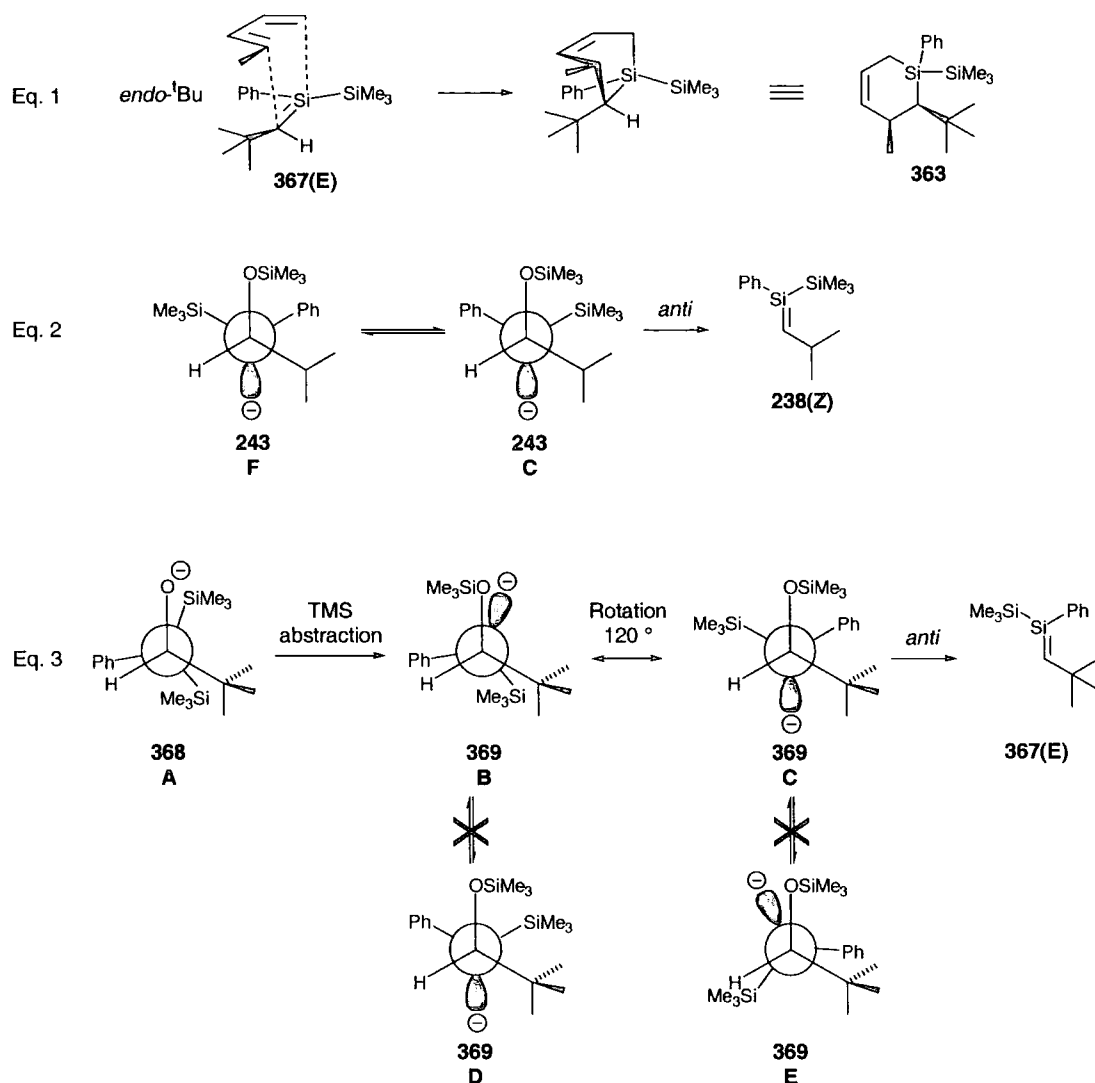

Scheme 158

5.3.1.2 Fleming-Tamao Oxidation and the Phenyl-Substituted Silacycle

Entries 2 and 4 in Table 18, above, showed that yields of only 16 and 21 % were obtained for the Fleming-Tamao oxidation. This was a recurring problem also observed during the screening of various dienes (Section 5.2). Changes in conditions, such as time, temperature and the presence of KF, resulted in no difference to the yield, so it was decided to verify the Fleming reaction by isolation of the silyl fluoride intermediate. This was carried out during the elaboration of phenyl-substituted silacycle **370**, which was generated in 45 % yield from the silyl alcohol and 1,3-pentadiene to give a mixture of 3 diastereoisomers in a ratio of 74 : 20 : 6 % by GC. Hydrogenation of **370** gave silacycle **371** as a mixture which produced only 2 peaks by GC (93 : 7) ascribed to the identical retention time of two diastereoisomers, Scheme 159. Treatment of **371** with $\text{BF}_3 \cdot 2\text{AcOH}$ followed by chromatography on silica gel allowed the separation of pure fluorosilanes **372** and **375** in good yield. It is speculated that the third minor diastereoisomer was inadvertently lost during purification. Tamao oxidation of each of the fluorosilanes gave the identical diols, further confirmed by conversion into

the lactone **374**. Comparison of the NMR spectra with literature data showed the stereochemistry of this lactone **374** to be the expected *trans*-isomer. This implied that the fluorosilanes **372** and **375** differed only at the silicon centre, as depicted (although the exact stereochemistry was not assigned).

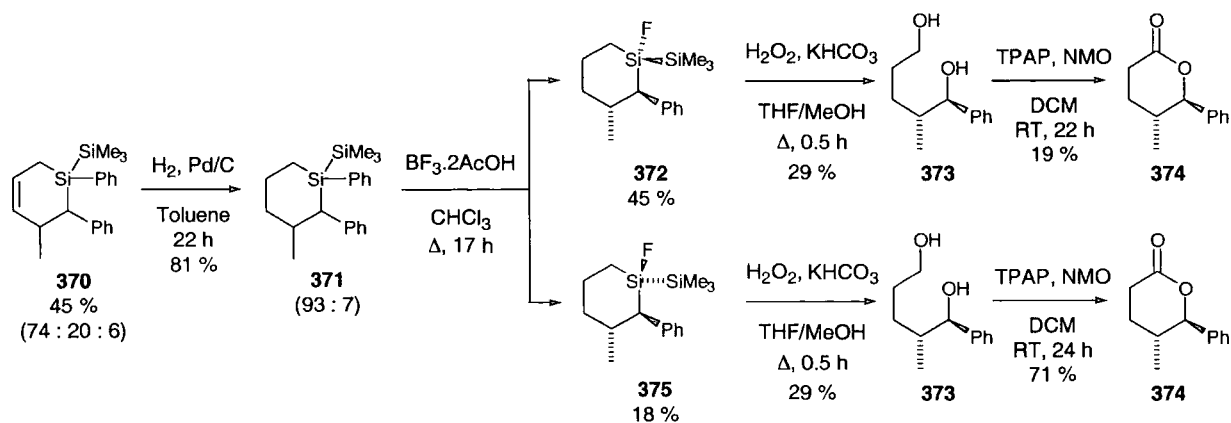

Scheme 159

5.3.2 Direct Oxidation of Unsaturated Silacycles

In Section 5.2.1 (page 85) it was shown that the silacycle derived from 1,3-pentadiene and ⁱPr-substituted silene could be treated directly with BF₃·2AcOH then hydrogen peroxide to afford the bishomoallylic alcohol. This was in contrast to silacycles with methyl substituents on the double bond which gave a mixture of decomposition products (see Section 5.2.2.2, page 92). The silacycles discussed in this section all result from 1,3-pentadiene and so can facilitate conversion into the bishomoallylic alcohol, as was demonstrated with *n*-Pr substituted silacycle **359**, Scheme 160.

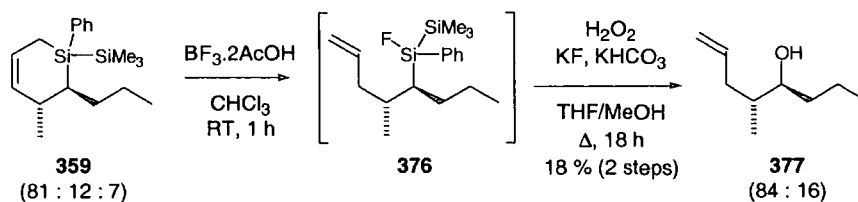

Scheme 160

The bishomoallylic alcohol **377** was isolated in only low yield which prompted isolation of the fluorosilane intermediate **378** during reaction of the phenyl-substituted silacycle **370**, Scheme 161. This strategy was successful and the bishomoallylic alcohol **379** was isolated in an overall yield of 44 %.

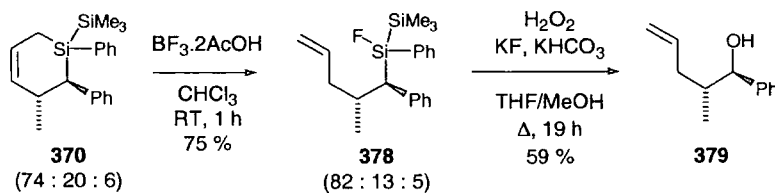

Scheme 161

5.4 Alternative Silacycle Elaborations

There is a plethora of synthetic manipulations an allylsilacycle could be made to undergo, before excision of the silyl unit (such as epoxidation, dihydroxylation, Diels-Alder cycloaddition, reaction with electrophiles, etc.), the scope of which is beyond the time available for the research carried out for this thesis but are reviewed by Hermanns and Schmidt.¹⁹³ As a preliminary investigation into functionalisation of the double bond, hydroboration was chosen. Brown has shown that hydroboration of vinylsilane **380** with $\text{BH}_3\cdot\text{THF}$ proceeds with very poor regioselectivity to give silylalkyl boranes **381** and **382**, Scheme 162. Subsequent oxidation with hydrogen peroxide afforded the corresponding silyl alcohols **383** and **384** in excellent overall yield. The low regioselectivity can be attributed to competition between steric effects, preferring terminal boronation, and the tendency of vinylsilanes to stabilise a β -carbocation favouring α -boronation.

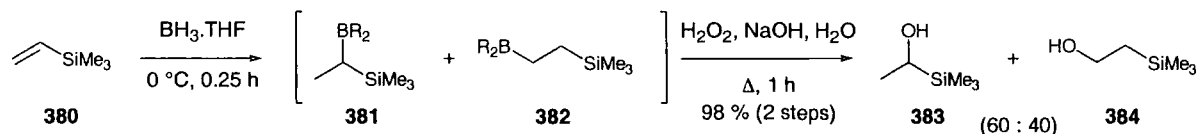

Scheme 162

This procedure was successfully applied to silacycle **183** to afford a mixture of two diastereoisomeric alcohols in a ratio of 76 : 24 % by NMR, Scheme 163. Consideration of the coupling constants in the ^1H NMR spectrum enabled determination of the stereochemistries of **387** and **388**, as depicted in the scheme. Thus coupling constants of 10.0 Hz for the proton geminal to the hydroxy group in **387** indicate its antiperiplanar relationship with neighbouring protons and hence the equatorial position of the hydroxy group. In contrast with the above vinylsilane, hydroboration of silacycle **183** occurred with high regioselectivity and establishes the viability of such a technique for future silacycle manipulations.

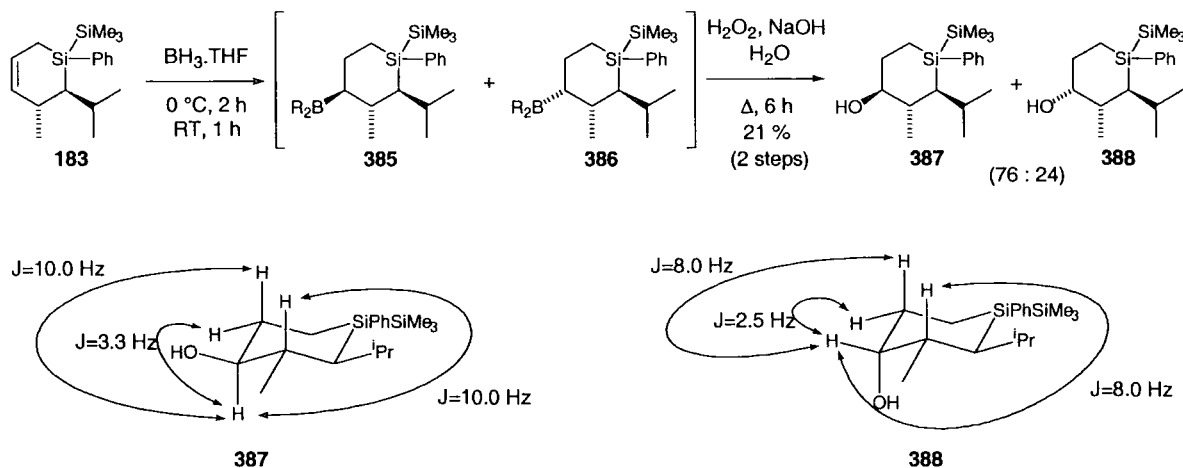

Scheme 163

5.5 Conclusions

The formation of silacycles from a [4+2] cycloaddition between a silene and 1,3-pentadiene is readily applicable to various alkyl-substituted silenes and the products can be converted into useful synthetic building blocks such as diols, lactones and bishomoallylic alcohols. The stereochemistry of the silacycle depends on two effects; the geometry of the silene, which is determined by the steric bulk of the alkyl substituent (only *t*-Bu gives *trans*), and whether the cycloaddition goes *endo* or *exo*. The latter is most strongly influenced by secondary orbital interactions between the phenyl group and the diene, which puts the phenyl group in the *endo*-position. Finally, a preliminary investigation has shown that hydroboration can be used to hydroxylate the double bond of a [4+2] silacycloadduct with mediocre regioselectivity.

6 Conclusions and Future Work

The research described in this thesis has involved the development of novel methods for the use of silenes in organic synthesis. The application of silene chemistry in this context has not been previously reported in the literature. Consequently, this research represents the first stepping stone to a potentially powerful synthetic technique.

In summary, a novel high-yielding synthesis of aryltris(trimethylsilyl)silanes has been invented and rationalised. Phenyltris(trimethylsilyl)silane has been used to form silyl alcohols which were the necessary precursors for silene generation through the modified Peterson olefination. A thorough investigation of this olefination revealed the importance of lithium bromide for the formation of silenes and hence led to the development of a robust and reproducible protocol. This was used to produce a range of silenes in the presence of various dienes to afford [4+2] silacycloadducts with satisfactory diastereoselectivity. Yields were around the 40-50 % mark which represents a target for future improvement. Finally, all of the silacycles were elaborated into useful products or synthetic building blocks including diols, bishomoallylic alcohols and lactones.

In future, the procedure could be used in the synthesis of specific target structures. For example, Scheme 164 suggests a synthesis of the Prelog-Djerassi lactone **390** from the commercially available enantiomerically pure starting material **389**. This also introduces the concept of enantioselective silene synthesis.

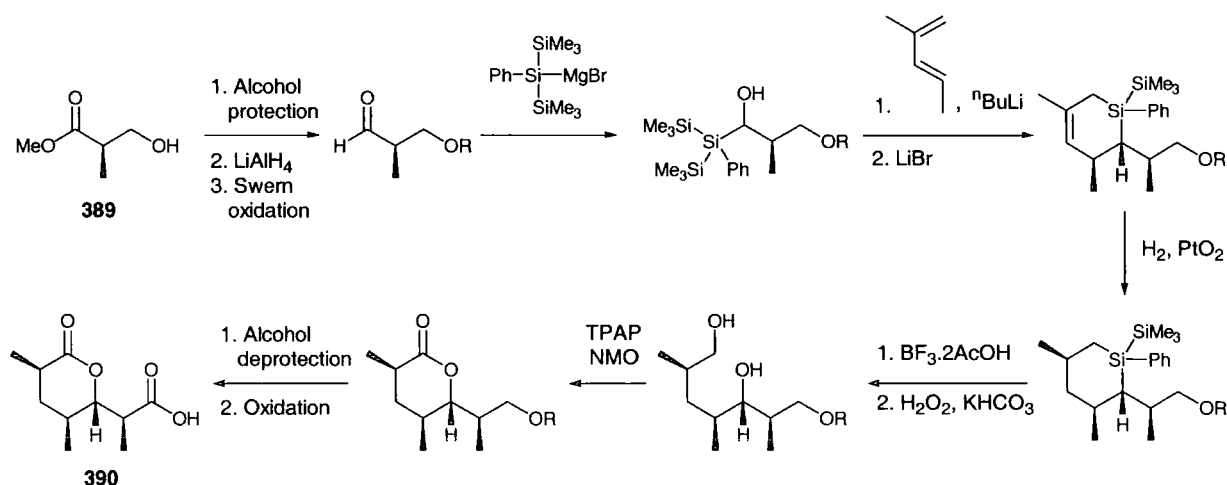

Scheme 164

Finally, it was shown in Section 5.4 (page 108) that hydroboration can be used to install a hydroxy group γ to silicon, but there also exists a plethora of alternative transformations

which the silacycle can be made to undergo prior to excision of the silyl unit, examples of which are given in Scheme 165. In particular, the silyl group should make attack by electrophiles, such as aldehydes or acyl-chlorides, highly regioselective due to its ability to stabilise a β -carbocation.

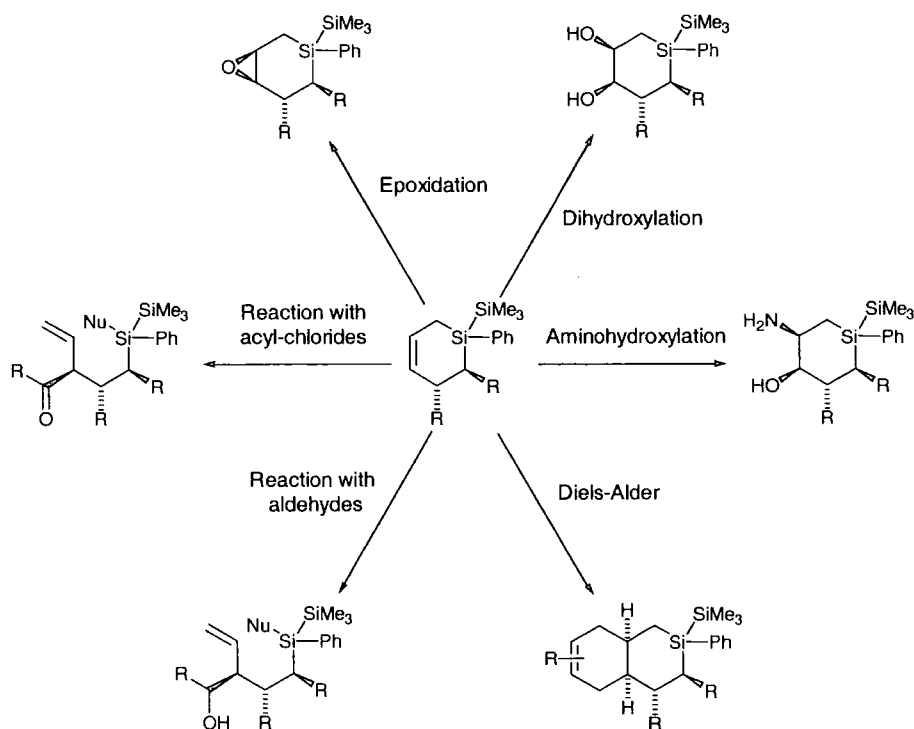

Scheme 165

7 Experimental Procedures

7.1 General Procedures

All reactions were carried out under an argon atmosphere in glassware dried under high vacuum by a heat-gun unless otherwise stated.

Solvents

Pet. ether refers to the fraction of petroleum ether boiling between 40 and 60 °C and was redistilled before use. Solvents were distilled from the following reagents under a nitrogen atmosphere: ether and THF (sodium benzophenone ketyl); DCM, xylene and benzene (calcium hydride); chloroform (phosphorous pentoxide); methanol (sodium methoxide). In cases where mixtures of solvents were utilised, the ratios given refer to the volumes used.

Reagents

Reagents were used as supplied unless otherwise stated. Lithium bromide was made anhydrous by heating at 100 °C at 0.06 mm Hg for 3 h. Where indicated, magnesium bromide was synthesised by addition of 1,2-dibromoethane to an equivalent amount of magnesium turnings in ether (1.5 M suspension).¹⁹⁴ Commercial magnesium bromide diethyl etherate was dried by stirring under vacuum for 2-3 h. Aldehydes and dienes were distilled, immediately prior to use, from anhydrous calcium sulfate and sodium borohydride, respectively.¹⁹⁵ Titrations of organometallic reagents were carried out in the following solvents; MeLi (benzene); ⁿBuLi (benzene); Grignard reagents (ether or THF); and according to the general procedure as applied to MeLi: Methyl lithium (approximately 1.6 M solution in ether, 2.5 ml) was added to a stirred solution of 1,10-phenanthroline (2 mg, 0.011 mmol) in dry benzene (10 ml) to produce a deeply coloured solution. *s*- or *t*-butanol (1 M solution in benzene) was added dropwise until a sudden colour change occurred.¹²⁸

Chromatography

Flash column chromatography was carried out using silica gel 40-63u 60A. Analytical thin layer chromatography (TLC) was performed using precoated glass-backed plates (silica gel 60 F₂₅₄) and visualised by UV radiation at 254 nm, or by staining with phosphomolybdic acid in ethanol or potassium permanganate and Na₂CO₃ in water.

Gas chromatography

Gas chromatography was carried out on a Hewlett-Packard 5890 Series II fitted with a 5 % diphenyl/95 % dimethylpolysiloxane column of 25 m length. Detection was by flame ionisation.

IR spectroscopy

Infrared spectra were recorded as thin films between KBr plates (liquids) or as compression-formed discs made using KBr (solids) on a Perkin-Elmer FT-IR 1600 spectrometer.

NMR spectroscopy

^1H NMR spectra were recorded in CDCl_3 or Acetone- d_6 on Varian Mercury 200, Bruker AM-250, Varian Unity-300, Varian VXR-400 or Varian Inova-500 and are reported as follows: chemical shift δ (ppm) (number of protons, multiplicity, coupling constant J (Hz), assignment). Residual protic solvent CHCl_3 ($\delta_{\text{H}} = 7.26$ ppm) or $\text{CD}_3\text{COCD}_2\text{H}$ ($\delta_{\text{H}} = 2.05$ ppm) was used as the internal reference. ^{13}C NMR spectra were recorded at 63 MHz, 101 MHz or 126 MHz on Bruker AM-250, Varian VXR-400 or Varian Inova-500 respectively, using the central resonance of CDCl_3 ($\delta_{\text{C}} = 77.0$ ppm) as the internal reference. ^{29}Si NMR spectra were recorded at 99 MHz on Varian Inova-500. ^{19}F NMR spectra were recorded at 376 MHz or 282 MHz on Varian VXR-400 or Varian Unity-300 respectively. All chemical shifts are quoted in parts per million relative to tetramethylsilane ($\delta_{\text{H}} = 0.00$ ppm) and coupling constants are given in Hertz to the nearest 0.3 Hz. Assignment of spectra was carried out using DEPT, COSY, HSQC and NOESY experiments.

Mass spectrometry

Low-resolution mass spectra (EI or CI) were obtained on a Micromass Autospec Mass Spectrometer. Gas chromatography-mass spectra (GCMS, EI or CI) were taken using a Hewlett Packard 5890 Series II gas chromatograph equipped with a 25 m column, connected to a VG Trio-1000. Electrospray mass spectra (ES) were obtained on a Micromass LCT Mass Spectrometer. High-resolution mass spectra were performed by the EPSRC service at the University of Swansea or on a Micromass Autospec Mass Spectrometer in Durham.

Stereochemistry

All products were synthesised as racemic mixtures. Chemical names of such chiral compounds give the stereochemistry of one enantiomer and are marked by '*'. For

example, (\pm)-(3R*,4S*) denotes a racemic mixture of enantiomers, one of which has stereochemistry 3R,4S and the other stereochemistry 3S,4R.

7.2 Experimental Detail

Tetrakis(trimethylsilyl)silane **189**^{10, 116}

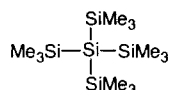

To a solution of chlorotrimethylsilane (224 ml, 1763 mmol) in THF (400 ml) was added pieces of lithium ribbon (31.0 g, 4462 mmol). A solution of silicon tetrachloride (43 ml, 375 mmol) in THF (300 ml) was prepared and 40 ml of this was added to the stirred TMSCl solution dropwise [**CAUTION: Exotherm**]. The reaction was stirred for 4 h at RT, then the remaining SiCl₄ solution was added over 2 h. The reaction was stirred overnight. The crude reaction mixture was filtered through celite to remove LiCl salt and brown polymeric material and washed through with ether. The filtrate was added to aqueous hydrochloric acid (5 M, 300 ml). The aqueous layer was separated and extracted with ether (3 x 140 ml). The combined organic layers were dried over MgSO₄, filtered, concentrated and dried *in vacuo*. Recrystallisation of the semisolid residue from acetone yielded the title compound as a white to cream crystalline solid (72.5 g, 60 %); m.p. 218-238 °C (sublimed) (lit. 261-263 °C); ν_{max} (thin film) 2950, 2894, 1439, 1394, 1246, 838 cm⁻¹; δ_{H} (200 MHz; CDCl₃) 0.20; δ_{C} (100 MHz; CDCl₃) 2.69; m/z (EI) 320 (M⁺, 19 %), 305 (M⁺-Me, 13 %), 232 (M⁺-Me-SiMe₃, 87 %), 174 (M⁺-2SiMe₃, 17 %), 173 (M⁺-2SiMe₃-H, 33 %); all data from which agrees with that given by Griffiths.

Tris(trimethylsilyl)silane **190**^{10, 117-119}

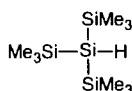

HAZARD: The pure compound is known to be spontaneously combustible in air.

To a solution of tetrakis(trimethylsilyl)silane **189** (10.05 g, 31 mmol) in THF (97 ml) was added methyl lithium (1.6 M solution in ether, 20.4 ml, 33 mmol) dropwise. The reaction mixture was stirred at RT for 48 h and then poured into hydrochloric acid (0.1 M, 360 ml, 36 mmol). The aqueous layer was separated and extracted with ether (3 x 60 ml). The combined organic layers were dried over MgSO₄, filtered, concentrated and dried *in vacuo*. Distillation gave the title compound as a clear oil (6.67 g, 86 %); b.p. 85 °C @ 8-11 mbar; δ_{H} (200 MHz; CDCl₃) 2.14 (1 H, s, Si-H), 0.19 (27 H, s, HSi(Si(CH₃)₃)₃); all data from which agrees with that given by Griffiths.

Phenyltris(trimethylsilyl)silane 174

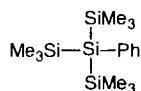

- **Method 1**¹⁰

To tris(trimethylsilyl)silane **190** (15.07 g, 61 mmol), under N₂, was added *n*-bromobutane (26 ml, 244 mmol). The mixture was refluxed at 100 °C for 24 h (the reaction was followed by GC until complete conversion of the starting material to the silyl bromide was observed). The mixture was allowed to cool to RT and as much remaining *n*-bromobutane was evaporated as possible under vacuum. Phenylmagnesium bromide (1 M solution in THF, 123 ml, 123 mmol) was added and the solution stirred for 24 h. Saturated ammonium chloride solution (60 ml) was added dropwise. The aqueous layer was separated and extracted with ether (3 x 60 ml). The combined organic layers were dried over MgSO₄, filtered, concentrated and dried *in vacuo*. Flash column chromatography (pet. ether) afforded the title compound as a grey amorphous waxy solid (10.15 g, 52 %).

- **Method 2**^{113, 115}

To a mixture of lithium wire (3.86 g, 556 mmol) and TMSCl (24.7 ml, 195 mmol) in THF (75 ml) was added trichlorophenylsilane (9.9 ml, 62 mmol) at 0 °C. The reaction mixture was stirred for 21 h at RT and then filtered through a pad of celite and washed through with ether. Hydrochloric acid (5 M, 45 ml) was added. The aqueous layer was separated and extracted with ether (3 x 40 ml). The combined organic layers were dried over MgSO₄, filtered, concentrated and dried *in vacuo*. Fractional distillation gave the title compound as a grey amorphous waxy solid (1.98 g, 10 %).

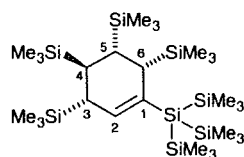

Recrystallisation, from ether, of the residue after distillation gave 1-tris(trimethylsilyl)silyl-3,4,5,6-tetrakis(trimethylsilyl)cyclohexene as large colourless hexagonal crystals (6.79 g, 18 %); m.p. 218.5-219 °C (lit. 215-216 °C); ν_{\max} (thin film) 2954, 2897, 2816, 2797, 1592 (C=C), 1442, 1402, 1251, 1187, 1153, 1094 cm⁻¹; δ_{H} (300 MHz; CDCl₃) 5.91 (1 H, d, J 6.0, 2-*H*), 2.02 (1 H, d, J 3.0, 6-*H*), 1.97 (1 H, dd, J 8.5, 6.0, 3-*H*), 1.54-1.47 (1 H, m, 4-*H*), 1.15 (1 H, dd, J 13.2, 3.0, 5-*H*), 0.21 (27 H, s, Si(Si(CH₃)₃)₃), 0.18 (9 H, s, C-Si(CH₃)₃), 0.15 (9 H, s, C-Si(CH₃)₃), 0.13 (9 H, s, C-Si(CH₃)₃), 0.07 (9 H, s, C-Si(CH₃)₃); δ_{C} (126 MHz; CDCl₃) 140.45 (2-*C*), 134.39 (1-*C*), 34.93, 32.08, 29.20, 21.77, 3.83, 2.33 (Si(Si(CH₃)₃)₃), 1.99, 1.08, 0.38; m/z (CI) 617 (M+H⁺, 3 %), 601 (M⁺-Me, 4 %), 453 (12 %), 369 (M⁺-

Si(SiMe₃)₃, 40 %), 354 (M⁺-Si(SiMe₃)₃-Me, 7 %), 353 (M⁺-Si(SiMe₃)₃-Me-H, 17 %), 339 (M⁺-Si(SiMe₃)₃-2Me-H, 28 %), 305 (22 %), 295 (11 %), 279 (57 %), 265 (30 %), 247 (69 %), 233 (37 %), 207 (100 %); Elemental analysis [Found: C, 51.16 %; H, 11.40 %; required for C₂₇H₆₈Si₈: C, 52.60; H, 10.96]; crystal structure: page 49; all data from which agrees with that given in the literature.¹²²

◦ **Method 3**¹²³

To a stirred suspension of sodium (3.55 g, 154 mmol) and potassium (27.08 g, 694 mmol) in dry xylene (140 ml) was added, dropwise over 2 h [CAUTION: Large exotherm (see Section 2.3.1 (page 49))], a mixture of phenyltrichlorosilane (24.7 ml, 154 mmol) and chlorotrimethylsilane (245 ml, 1921 mmol) at RT. The mixture was refluxed overnight. It was filtered through a pad of celite and washed through with ether. The filtrate was concentrated and dried *in vacuo*. Fractional distillation gave the title compound as a grey amorphous waxy solid (6.36 g, 13 %).

◦ **Method 4**

To a suspension of magnesium turnings (0.72 g, 30 mmol) in a mixture of THF/HMPA [CAUTION: Cancer suspect agent] (1:1, 30 ml) was added a mixture of phenyltrichlorosilane (1.48 ml, 9.3 mmol) and chlorotrimethylsilane (3.6 ml, 29 mmol) at a high enough rate to maintain a gentle reflux.¹⁰ The mixture was then refluxed for 23 h. Saturated ammonium chloride solution (30 ml) was added dropwise. The aqueous layer was separated and extracted with ether (3 x 30 ml). The combined organic layers were dried over MgSO₄, filtered, concentrated and dried *in vacuo*. Flash column chromatography (hexane) gave the product as an inseparable mixture.

◦ **Method 5**

To a solution of dry tetrakis(trimethylsilyl)silane **189** (30.0 g, 93.8 mmol.), in dry THF (390 ml) under argon, was added methyllithium (1.6 M solution in ether, 58.6 ml, 93.8 mmol) dropwise. The reaction mixture was stirred at RT for 16 h after which time it became dark red and GC showed complete consumption of the starting material. This solution was added *via* canula to a solution of bromine (4.8 ml, 93.8 mmol) in THF (75 ml) at -78 °C.¹²⁶ The reaction mixture was allowed to warm to ambient temperature and stirred at this temperature until GC showed complete consumption of the silyl anion (detected via the corresponding silyl hydride) and generation of the silyl bromide (about 2 h). The solution was then re-cooled to -78 °C and freshly prepared phenylmagnesium bromide (173.5 mmol) in THF (65 ml) was added. The mixture was allowed to warm to RT and stirred until complete

consumption of the bromide had occurred by GC (about 1.5 h). The mixture was then immediately quenched with saturated ammonium chloride solution (130 ml). The aqueous layer was separated and extracted with ether (3 x 100 ml). The combined organic layers were dried over MgSO₄, filtered, concentrated and dried *in vacuo*. Flash column chromatography (pet. ether) afforded **1** as a grey amorphous waxy solid (19.07 g, 63 %).

◦ **Method 6**

Dry tetrakis(trimethylsilyl)silane **189** (0.76 g, 2.37 mmol) and potassium-*tert*-butoxide (0.27 g, 2.37 mmol) were combined under argon. Dry THF (13 ml) was added and the solution stirred for 2-3 h after which time it was dark red.¹³⁰ This was transferred *via* canula to a solution of tetra-*n*-butylammonium tribromide in THF (2 ml) at -78 °C over 15 min. The mixture was warmed to RT and, after 2.5 h, was re-cooled to -78 °C. Phenylmagnesium bromide (1.0 M solution in THF, 4.7 ml, 4.7 mmol) was added and the mixture allowed to warm to RT. After stirring for 20 h, saturated ammonium chloride solution (15 ml) was added. The aqueous layer was separated and extracted with ether (3 x 15 ml). The combined organic layers were dried over MgSO₄, filtered, concentrated and dried *in vacuo*. Flash column chromatography (isohexane) afforded **1** as a grey amorphous waxy solid (0.12 g, 16 %).

◦ **Method 7**

Dry tetrakis(trimethylsilyl)silane **189** (2.11g, 6.59 mmol) and potassium-*tert*-butoxide (0.78 g, 6.91 mmol) were combined under argon. Dry THF (26 ml) was added and the solution stirred for 3 h after which time it was dark red.¹³⁰ This was transferred *via* canula to a solution/suspension of *N*-bromosuccinimide in THF (4 ml) at RT over 55 min and stirred for 20 h. The mixture was cooled to -50 °C and phenylmagnesium bromide (1.0 M solution in THF, 13.2 ml, 13.2 mmol) was added. After stirring a -50 °C for 15.5 h, it was warmed to -30 °C and stirred for 40 min. It was then held at -5 °C for 1 h before being warmed to RT and stirred for 69 h. GC showed incomplete conversion to product, so more phenylmagnesium bromide (1.0 M, 9.9 ml, 9.9 mmol) was added and the solution stirred for a further 3.5 h. Saturated ammonium chloride solution (20 ml) was then added. The aqueous layer was separated and extracted with ether (3 x 20 ml). The combined organic layers were dried over MgSO₄, filtered, concentrated and dried *in vacuo*. Flash column chromatography (isohexane) afforded **1** as a grey amorphous waxy solid (0.74 g, 35 %).

o Method 8

Dry tetrakis(trimethylsilyl)silane **189** (18.66 g, 58.31 mmol) and potassium-*tert*-butoxide (6.87 g, 61.23 mmol) were combined under argon. Dry THF (280 ml) was added and the solution stirred for 2 h, after which time it was dark red.¹³⁰ Phenylmagnesium bromide (1.0 M, 64.1 ml, 64.1 mmol) was added upon which a white precipitate formed. The mixture was stirred for 1 h and then cooled to $-78\text{ }^{\circ}\text{C}$. Bromobenzene (9.2 ml, 87.5 mmol) was quickly added with rapid stirring which created an exotherm (observed as effervescence in the dry ice/acetone bath). After stirring for 1 h, the mixture was warmed to RT for 30 min and more phenylmagnesium bromide (1.0 M, 93.3 ml, 93.3 mmol) was added. The mixture was refluxed until GC showed the reaction complete (137 h). Saturated ammonium chloride solution (280 ml) was then added. The aqueous layer was separated and extracted with ether (3 x 280 ml). The combined organic layers were dried over MgSO_4 , filtered, concentrated and dried *in vacuo*. Flash column chromatography (pet. ether) followed by Kugelrohr distillation afforded the title compound as a grey amorphous waxy solid (13.03 g, 69 %).

o Method 9

Dry tetrakis(trimethylsilyl)silane **189** (17.47 g, 54.59 mmol) and potassium-*tert*-butoxide (6.43 g, 57.32 mmol) were combined under argon. Dry THF (260 ml) was added and the solution stirred for 2 h after which time it was dark red.¹³⁰ Phenylmagnesium bromide (1.0 M, 60 ml, 60 mmol) was added upon which a white precipitate formed. The mixture was stirred for 1 h and then cooled to $-78\text{ }^{\circ}\text{C}$. Bromobenzene (8.6 ml, 81.9 mmol) was quickly added with rapid stirring which created an exotherm (observed as effervescence in the dry ice/acetone bath). After stirring for 1 h, the mixture was warmed to RT and dry magnesium bromide diethyl etherate (1.41 g, 5.46 mmol) was added. The mixture was refluxed until GC showed the reaction complete (18 h). Saturated ammonium chloride solution (260 ml) was then added. The aqueous layer was separated and extracted with ether (3 x 260 ml). The combined organic layers were dried over MgSO_4 , filtered, concentrated and dried *in vacuo*. Flash column chromatography (pet. ether) followed by Kugelrohr distillation afforded the title compound as a grey amorphous waxy solid (12.93 g, 73 %); R_f (*n*-hexane) 0.74; m.p. 82.0-83.0 $^{\circ}\text{C}$ (lit. 84-85 $^{\circ}\text{C}$)¹⁹⁶; b.p. 95 $^{\circ}\text{C}$ @ 0.1 mm Hg (lit. 132 $^{\circ}\text{C}$ @ 1.5 mm Hg)¹¹³; ν_{max} (thin film) 3066, 2954, 2896, 1430, 1250 cm^{-1} ; δ_{H} (300 MHz; CDCl_3) 7.46-7.42 (2 H, m, *ortho* Ar-H), 7.26-7.23 (3 H, m, *meta* and *para* Ar-H), 0.22 (27 H, s, $\text{Si}(\text{Si}(\text{CH}_3)_3)_3$); δ_{C} (63 MHz; CDCl_3) 136.56 (*Ar*), 135.53 (*Ar*), 127.68 (*Ar*), 127.31 (*Ar*), 1.17 ($\text{Si}(\text{Si}(\text{CH}_3)_3)_3$); δ_{Si} (99 MHz; CDCl_3) -12.79 (*SiMe}_3*), -76.82 (*Ar-Si*); m/z (EI) 324 (M^+ , 30 %), 309 ($\text{M}^+ - \text{Me}$, 12 %), 251 ($\text{M}^+ - \text{SiMe}_3$, 17 %), 236 ($\text{M}^+ - \text{Me} - \text{SiMe}_3$, 22 %), 191

(25 %), 174 (M^+ -Ph-SiMe₃, 70 %), 159 (M^+ -Ph-SiMe₃-Me, 26 %), 135 (24 %), 73 (Me₃Si⁺, 100 %); all data from which agrees with that given by Griffiths and published in the literature.^{10, 57}

***N*-Tris(trimethylsilyl)silylsuccinimide 203**

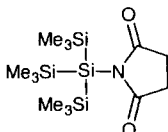

Dry tetrakis(trimethylsilyl)silane **189** (3.70 g, 11.54 mmol) and potassium-*tert*-butoxide (1.36 g, 12.12 mmol) were combined under argon. Dry THF (52 ml) was added and the solution stirred for 3 h after which time it was dark red. It was transferred *via* canula to a solution/suspension of *N*-bromosuccinimide in THF (7 ml) at RT over 1 h and stirred for 2.5 h. Water (30 ml) was added and the aqueous layer was separated and extracted with ether (3 x 30 ml). The combined organic layers were dried over MgSO₄, filtered, concentrated and dried *in vacuo*. Flash column chromatography (isohexane/ether [9:1]) gave the title compound as a white crystalline solid (0.82 g, 21 %); *R_f* (isohexane/ether [9:1]) 0.14; m.p. 121.0-124.0 °C; ν_{\max} (KBr disc) 2949, 2893, 1679 (C=O), 1323, 1241, 1169, 1008, 992, 874, 689, 625 cm⁻¹; δ_{H} (400 MHz; CDCl₃) 2.68 (4 H, s, CH₂-CH₂), 0.20 (27 H, s, Si(Si(CH₃)₃)₃); δ_{C} (101 MHz; CDCl₃) 183.01 (C=O), 30.67 (CH₂-CH₂), 1.27 (Si(Si(CH₃)₃)₃); *m/z* (ES⁺) 346 (M+H⁺, 67 %), 330 (M⁺-Me, 78 %), 272 (M⁺-SiMe₃, 100 %); HRMS (ES⁺) Found: 346.1498 (C₁₃H₃₂O₂Si₄ (M+H⁺) requires 346.1510).

4-Methoxyphenyltris(trimethylsilyl)silane

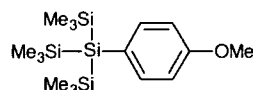

• **Method 1**

To a solution of dry tetrakis(trimethylsilyl)silane **189** (5.33 g, 16.7 mmol.), in dry THF (65 ml) under argon, was added methyllithium (1.6 M solution in ether, 12.6 ml, 16.7 mmol) dropwise. The reaction mixture was stirred at RT for 17 h after which time it became dark red and GC showed complete consumption of the starting material. This solution was added *via* canula to a solution of bromine (0.85 ml, 16.7 mmol) in THF (14 ml) at -78 °C.¹²⁶ The reaction mixture was allowed to warm to ambient temperature and stirred at this temperature until GC showed complete consumption of the silyl anion (detected via the corresponding silyl hydride) and generation of the silyl bromide (about 2 h). The solution was then re-cooled to -78 °C and freshly prepared 4-methoxyphenylmagnesium bromide (33.3 mmol) in THF (12 ml) was added. The mixture was allowed to warm to RT and stirred until

maximum formation of product occurred (about 2.5 h). The mixture was then immediately quenched with saturated ammonium chloride solution (23 ml). The aqueous layer was separated and extracted with ether (3 x 30 ml). The combined organic layers were dried over MgSO₄, filtered, concentrated and dried *in vacuo*. Flash column chromatography (pet. ether) followed by distillation (Kugelrohr) afforded the title compound as a thick colourless oil (0.60 g, 11 %).

• Method 2

Dry tetrakis(trimethylsilyl)silane **189** (2.47 g, 7.72 mmol) and potassium-*tert*-butoxide (0.91 g, 8.11 mmol) were combined under argon. Dry THF (45 ml) was added and the solution stirred for 2 h after which time it was dark red.¹³⁰ 4-Methoxyphenylmagnesium bromide (0.5 M, 17.0 ml, 8.49 mmol) was added upon which a white precipitate formed. The mixture was stirred for 1 h and then cooled to -78 °C. 4-Bromoanisole (1.45 ml, 11.58 mmol) was quickly added with rapid stirring which created an exotherm (observed as effervescence in the dry ice/acetone bath). After stirring for 1 h, the mixture was warmed to RT for 30 min and further 4-methoxyphenylmagnesium bromide (0.5 M, 24.7 ml, 12.35 mmol) was added. The mixture was refluxed until GC showed the reaction complete (18 h). Saturated ammonium chloride solution (45 ml) was then added. The aqueous layer was separated and extracted with ether (3 x 45 ml). The combined organic layers were dried over MgSO₄, filtered, concentrated and dried *in vacuo*. Flash column chromatography (pet. ether) followed by removal of excess 4-bromoanisole by Kugelrohr distillation afforded the title compound as an amorphous white semi-solid (1.50 g, 55 %); ν_{\max} (thin film) 2949, 2894, 2834, 1592, 1562, 1496, 1461, 1441, 1395, 1273, 1244, 1180, 1089, 1034, 866, 833, 687 cm⁻¹; δ_{H} (250 MHz; CDCl₃) 7.36 (2 H, d, J 8.5, Ar-*H*), 6.84 (2 H, d, J 8.5, Ar-*H*), 3.79 (3 H, s, OMe), 0.22 (27 H, s, Si(Si(CH₃)₃)₃); δ_{C} (63 MHz; CDCl₃) 159.31 (C-O), 137.70 (Ar), 125.23 (C-Si), 113.68 (Ar), 54.88 (OMe), 1.15 (Si(Si(CH₃)₃)₃); δ_{Si} (99 MHz; CDCl₃) -12.94 (SiMe₃), -77.76 (Ar-Si); m/z (CI) 355 (M+H⁺, 100 %), 339 (M⁺-Me, 2 %), 297 (3 %), 281 (M⁺-SiMe₃, 2 %), 264 (13 %); HRMS (EI) Found: 354.1684 (C₁₆H₃₄OSi₄ (M⁺) requires 354.1687).

p-Tolyltris(trimethylsilyl)silane **216**

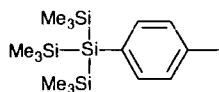

Dry tetrakis(trimethylsilyl)silane **189** (2.07 g, 6.39 mmol) and potassium-*tert*-butoxide (0.76 g, 6.71 mmol) were combined under argon. Dry THF (38 ml) was added and the solution stirred for 2.5 h after which time it was dark red.¹³⁰ *p*-Tolylmagnesium bromide (1.0 M, 7.0

ml, 7.0 mmol) was added upon which a white precipitate formed. The mixture was stirred for 1 h and then cooled to $-78\text{ }^{\circ}\text{C}$. 4-Bromotoluene (1.18 ml, 9.59 mmol) was quickly added with rapid stirring which created an exotherm (observed as effervescence in the dry ice/acetone bath). After stirring for 1 h, the mixture was warmed to RT and further *p*-tolylmagnesium bromide (1.0 M, 10.2 ml, 10.2 mmol) was added. The mixture was refluxed until GC showed the reaction complete (21 h). Saturated ammonium chloride solution (38 ml) was then added. The aqueous layer was separated and extracted with ether (3 x 38 ml). The combined organic layers were dried over MgSO_4 , filtered, concentrated and dried *in vacuo*. Flash column chromatography (pet. ether) followed by Kugelrohr distillation afforded the title compound as a colourless oil (1.03 g, 48 %); R_f (pet. ether) 0.77; b.p. $65\text{--}70\text{ }^{\circ}\text{C}$ @ 0.04 mm Hg; ν_{max} (thin film) 3064, 3013, 2949, 2893, 1495, 1440, 1394, 1245, 1085, 866, 834, 687 cm^{-1} ; δ_{H} (500 MHz; CDCl_3) 7.35 (2 H, d, J 8.0, Ar-H), 7.09 (2 H, d, J 8.0, Ar-H), 2.32 (3 H, s, Ar- CH_3), 0.22 (27 H, s, $\text{Si}(\text{Si}(\text{CH}_3)_3)_3$); δ_{C} (126 MHz; CDCl_3) 136.99 (Ar), 136.54 (Ar), 131.22 (Ar), 128.63 (Ar), 21.33 (Ar- CH_3), 1.16 ($\text{Si}(\text{Si}(\text{CH}_3)_3)_3$); δ_{Si} (99 MHz; CDCl_3) -12.89 (SiMe_3), -77.46 (Ar-Si); m/z (GCMS, EI) 338 (M^+ , 32 %), 323 ($\text{M}^+ - \text{Me}$, 12 %), 265 ($\text{M}^+ - \text{SiMe}_3$, 25 %), 250 (13 %), 249 (13 %), 235 (10 %), 205 (26 %), 191 (50 %), 174 (100 %), 159 (39 %), 149 (72 %); HRMS (EI) Found: 338.1738 ($\text{C}_{16}\text{H}_{34}\text{Si}_4$ (M^+) requires 338.1738).

4-Fluorophenyltris(trimethylsilyl)silane

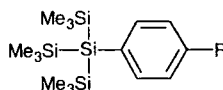

Dry tetrakis(trimethylsilyl)silane **189** (1.79 g, 5.58 mmol) and potassium-*tert*-butoxide (0.67 g, 5.97 mmol) were combined under argon. Dry THF (27 ml) was added and the solution stirred for 2 h after which time it was dark red.¹³⁰ 4-Fluorophenylmagnesium bromide (1.0 M, 8.1 ml, 8.1 mmol) was added upon which a white precipitate formed. The mixture was stirred for 2 h and then cooled to $-78\text{ }^{\circ}\text{C}$. 4-Bromofluorobenzene (0.92 ml, 8.37 mmol) was quickly added with rapid stirring which created an exotherm (observed as effervescence in the dry ice/acetone bath). After stirring for 1.5 h, the mixture was warmed to RT for 1 h and further 4-fluorophenylmagnesium bromide (1.0 M, 3.4 ml, 3.4 mmol) was added. After 46 h at RT, GC showed little product, but large amounts of intermediate silyl bromide, so the mixture was refluxed for 50 h, but no change was seen by GC. Extra 4-fluoromagnesium bromide (1.0 M, 4.2 ml, 4.2 mmol) was therefore added and stirred for 24 h after which time GC showed the reaction complete. Saturated ammonium chloride solution (25 ml) was then added. The aqueous layer was separated and extracted with ether (3 x 25 ml). The combined organic layers were dried over MgSO_4 , filtered, concentrated and dried *in vacuo*.

Flash column chromatography (pet. ether) followed by Kugelrohr distillation afforded the title compound as a clear oil (1.23 g, 64 %); R_f (pet. ether) 0.85; b.p. 72-75 °C @ 0.07 mm Hg; ν_{\max} (thin film) 2949, 2893, 1586, 1493, 1397, 1245, 1231, 1161, 1083, 865, 834, 746, 687, 624, 513 cm^{-1} ; δ_H (200 MHz; CDCl_3) 7.43-7.36 (2 H, m, 3,5-*H*), 7.01-6.92 (2 H, m, 2,6-*H*), 0.21 (27 H, s, $\text{Si}(\text{Si}(\text{CH}_3)_3)_3$); δ_C (126 MHz; CDCl_3) 162.87 (d, J 247.5, 4-*C*), 137.95 (d, J 7.3, 2,6-*C*), 130.52 (d, J 3.8, 1-*C*), 114.95 (d, J 19.7, 3,5-*C*), 1.08 ($\text{Si}(\text{Si}(\text{CH}_3)_3)_3$); δ_F (376 MHz; CDCl_3) -114.98 (m); δ_{Si} (99 MHz; CDCl_3) -12.85 (SiMe_3), -76.84 (Ar-*Si*); m/z (GCMS, EI) 342 (M^+ , 76 %), 327 (M^+ -Me, 36 %), 269 (M^+ - SiMe_3 , 8 %), 254 (32 %), 253 (30 %), 250 (M^+ - SiMe_3 -F, 48 %), 239 (45 %), 235 (48 %), 211 (33 %), 209 (42 %), 208 (39 %), 195 (61 %), 192 (100 %), 174 (100 %), 159 (79 %), 153 (79 %); HRMS (EI) Found: 342.1490 ($\text{C}_{16}\text{H}_{31}\text{F}_3\text{Si}_4$ (M^+) requires 342.1487).

4-Trifluoromethylphenyltris(trimethylsilyl)silane

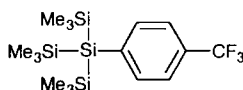

Dry tetrakis(trimethylsilyl)silane **189** (1.77 g, 5.53 mmol) and potassium-*tert*-butoxide (0.65 g, 5.80 mmol) were combined under argon. Dry THF (32 ml) was added and the solution stirred for 2 h after which time it was dark red.¹³⁰ 4-Trifluoromethylphenylmagnesium bromide (22.1 mmol) was prepared by the addition of 4-bromobenzotrifluoride (3.1 ml, 22.1 mmol) in ether (24.5 ml) to magnesium turnings (0.64 g, 26.3 mmol) at a rate to maintain reflux.¹⁹⁷ A portion of this Grignard reagent (0.8 M, 7.6 ml, 6.08 mmol) was added to the silyl-potassium solution upon which a white precipitate formed. The mixture was stirred for 1 h and then cooled to -78 °C. 4-bromobenzotrifluoride (1.16 ml, 8.29 mmol) was quickly added with rapid stirring which created an exotherm (observed as effervescence in the dry ice/acetone bath). After stirring for 1 h, the mixture was warmed to RT and further 4-trifluoromethylphenylmagnesium bromide (0.8 M, 11.1 ml, 8.84 mmol) was added. The mixture was refluxed for 138 h. Saturated ammonium chloride solution (32 ml) was then added. The aqueous layer was separated and extracted with ether (3 x 32 ml). The combined organic layers were dried over MgSO_4 , filtered, concentrated and dried *in vacuo*. Flash column chromatography (pet. ether) followed by Kugelrohr distillation afforded the title compound as a clear oil (0.68 g, 31 %); R_f (pet. ether) 0.92; b.p. 72-75 °C @ 0.07 mm Hg; ν_{\max} (thin film) 2951, 2894, 1604, 1389, 1325, 1260, 1247, 1165, 1127, 1101, 1057, 1017, 835, 694 cm^{-1} ; δ_H (500 MHz; CDCl_3) 7.57 (2 H, d, J 8.0, 3,5-*H*), 7.50 (2 H, d, J 8.0, 2,6-*H*), 0.24 (27 H, s, $\text{Si}(\text{Si}(\text{CH}_3)_3)_3$); δ_C (126 MHz; CDCl_3) 141.90, 136.52, 129.36 (q, J 32.3, 6-*C*), 124.42 (q, J 272.5, CF_3), 124.08 (q, J 3.3, 3,5-*C*), 1.10 ($\text{Si}(\text{Si}(\text{CH}_3)_3)_3$); δ_F (282 MHz; CDCl_3) -63.20 (s); δ_{Si} (99 MHz; CDCl_3) -12.60, -75.79; m/z (GCMS, EI) 392

(M⁺+H, 5 %), 304 (5 %), 300 (5 %), 259 (4 %), 245 (17 %), 230 (17 %), 203 (25 %), 193 (64 %), 174 (46 %), 159 (26 %), 145 (40 %), 131 (40 %); HRMS (EI) Found: 392.1456 (C₁₆H₃₄F₃Si₄ requires 392.1455).

1,1,1,3,3,3-hexamethyl-2-phenyl-2-(1'-hydroxy-2'-methylpropyl)trisilane 182

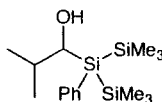

◦ Method 1¹⁰

Methylolithium (1.6 M solution in ether, 21 ml, 33 mmol) was added to a stirred solution of phenyltris(trimethylsilyl)silane **174** (10.15 g, 31.3 mmol) in THF (56 ml) at 0 °C. This was allowed to warm to RT and stirred for 17 h to produce a dark red solution of the silyl anion. The THF was evaporated directly using a vacuum manifold and ether (50 + 6 ml) was added. The resulting solution was added *via* canula to a suspension of magnesium bromide diethyl etherate (11.33 g, 43.9 mmol) in ether (56 ml). After becoming a homogeneous solution, the reaction mixture was stirred for 1 h and was then cooled to -78 °C. Freshly distilled isobutyraldehyde (4.3 ml, 47 mmol) was added dropwise. The reaction was then stirred for 19 h. Saturated ammonium chloride solution (100 ml) was added and the mixture allowed to reach RT. The aqueous layer was separated and extracted with ether (3 x 100 ml). The combined organic layers were dried over MgSO₄, filtered, concentrated and dried *in vacuo*. Flash column chromatography, gradient elution (pet. ether; pet. ether/ether [29:1]; [19:1]; [12:1]; ether) gave a mixture of the starting material phenyltris(trimethylsilyl)silane (PhSi(SiMe₃)₃) **174** and bis(trimethylsilyl)phenylsilane (PhSi(H)(SiMe₃)₂) **217** (0.79 g, 10 % and 8 %, respectively, calculated from NMR); R_f (pet. ether/ether [9:1]) 0.89; δ_H for **217** (300 MHz; CDCl₃) 7.46-7.40 (2 H, m, Ar-*H*), 7.28-7.23 (3 H, m, Ar-*H*), 3.74 (1 H, s, Si-*H*), 0.22 (18 H, s, Si(Si(CH₃)₃)₂). This was followed by the title compound as a colourless oil (6.76 g, 67 %).

◦ Method 2

Dry phenyltris(trimethylsilyl)silane **174** (4.82 g, 14.88 mmol) and potassium *tert*-butoxide (1.72 g, 15.33 mmol) were combined under Ar. THF (27 ml) was added and the resulting solution stirred for 2 h after which time it had become bright red.¹³⁰ The THF was evaporated directly using a vacuum manifold and ether (20 + 7 ml) was added. The resulting solution was added *via* canula to a suspension of magnesium bromide diethyl etherate (5.00 g, 19.3 mmol) in ether (27 ml). The reaction mixture was stirred for 1 h and was then cooled to -78 °C. Freshly distilled isobutyraldehyde (1.49 ml, 16.37 mmol) was added and the mixture stirred for 17 h. Saturated ammonium chloride solution (50 ml) was

added and the mixture allowed to reach RT. The aqueous layer was separated and extracted with ether (3 x 50 ml). The combined organic layers were dried over MgSO₄, filtered, concentrated and dried *in vacuo*. Flash column chromatography, gradient elution (pet. ether; pet. ether/ether [39:1]; [29:1]) gave a mixture of the starting material phenyltris(trimethylsilyl)silane (PhSi(SiMe₃)₃) **174** and bis(trimethylsilyl)phenylsilane (PhSi(H)(SiMe₃)₂) **217** (1.09 g, 2 % and 26 %, respectively, calculated from NMR). This was followed by the title compound as a colourless oil (2.50 g, 52 %); R_f (pet. ether/ether [9:1]) 0.57; ν_{max} (thin film) 3590 and 3480 (broad, O-H), 3070, 3054, 2955, 2900, 2820, 1468, 1430, 1245 (Si-C), 1100, 988, 835 cm⁻¹; δ_H (300 MHz; CDCl₃) 7.54-7.45 (2 H, m, Ar-H), 7.30-7.28 (3 H, m, Ar-H), 3.79 (1 H, d, J 6.9, CHOH), 1.96 (1 H, octet, J 6.9, CH(Me)₂), 0.99 and 0.88 (3 H, d, J 6.9, CH(CH₃)₂), 0.24 and 0.20 (9 H, s, Si(CH₃)₃); δ_C (63 MHz; CDCl₃) 136.44 (Ar), 135.60 (Ar), 128.04 (Ar), 127.83 (Ar), 72.39 (Si-CH), 34.63 (CH(Me)₂), 21.18 and 19.88 (CH(CH₃)₂), 0.50 (Si(CH₃)₃), 0.32 (Si(CH₃)₃); m/z (CI) 342 (M+NH₄⁺, 100 %), 324 (M⁺, 90 %), 307 (M⁺-OH, 68 %); all data from which agrees with that given by Griffiths.¹⁰

Isobutyric acid 1-(1',1',1',3',3',3'-hexamethyl-2'-phenyl-trisilan-2'-yl)-2-methyl-propyl ester **221**

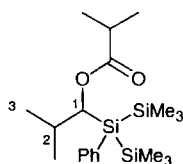

Ester **221** was sometimes obtained as a by-product of the above reaction (see Section 3.2, page 65), a pure sample could be separated from the desired silyl-alcohol **182** by repeated chromatography as above. R_f (pet. ether/ether [9:1]) 0.61; ν_{max} (thin film) 3070, 3050, 2963, 2894, 1730 (C=O), 1469, 1427, 1385, 1246, 1187, 1153, 1095, 837 cm⁻¹; δ_H (300 MHz; CDCl₃) 7.50-7.46 (2 H, m, Ar-H), 7.30-7.25 (3 H, m, Ar-H), 5.38 (1 H, d, J 7.0, 1-H), 2.49 (1 H, septet, J 6.9, Me₂CH-C=O), 2.05 (1 H, octet, J 7.0, 2-H), 1.15 (3 H, d, J 6.9, C=O-CH(CH₃)₂), 1.07 (3 H, d, J 6.9, C=O-CH(CH₃)₂), 0.87 (3 H, d, J 7.0, 3-H₃), 0.84 (3 H, J 7.0, 3-H₃), 0.22 (18 H, s, Si(Si(CH₃)₃)₂); δ_C (63 MHz; CDCl₃) 176.74 (C=O), 135.71 (Ar), 135.55 (Ar), 128.07 (Ar), 127.72 (Ar), 72.49 (Si-CH), 34.45 and 33.51 (CH(Me)₂'s), 21.19, 20.09, 19.62 and 18.69 (CH(CH₃)₂'s), 0.28 (9 H, s, Si(CH₃)₃), 0.10 (9 H, s, Si(CH₃)₃); m/z (CI) 379 (M⁺-Me, 8 %), 321 (M⁺-SiMe₃, 30 %), 265 (M⁺-Me-ⁱPrCO-ⁱPr, 100 %), 251 ([PhSi(SiMe₃)₂]⁺, 32 %); HRMS (CI) Found: 412.2525 (C₂₀H₄₂NO₂Si₃ (M+NH₄⁺) requires 412.2523).

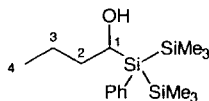
1,1,1,3,3,3-hexamethyl-2-phenyl-2-(1'-hydroxybutyl)trisilane 218

- **Method 1**¹⁰

Methylolithium (1.6 M solution in ether, 1.88 ml, 2.41 mmol) was added to a stirred solution of phenyltris(trimethylsilyl)silane **174** (0.78 g, 2.41 mmol) in THF (7.5 ml) at 0 °C. This was allowed to warm to RT and stirred for 21 h to produce a dark red solution of the silyl anion. The THF was evaporated directly using a vacuum manifold and ether (6 ml) was added. The resulting solution was added *via* canula to a suspension of magnesium bromide (0.45 g, 2.46 mmol) in ether (6 ml). After becoming a homogeneous solution, the reaction mixture was stirred for 1 h and was then cooled to -78 °C. Butyraldehyde (0.43 ml, 4.81 mmol) was added dropwise. The reaction was then stirred for 18 h. Saturated ammonium chloride solution (13 ml) was added and the mixture allowed to reach RT. The aqueous layer was separated and extracted with ether (3 x 13 ml). The combined organic layers were dried over MgSO₄, filtered, concentrated and dried *in vacuo*. Flash column chromatography, gradient elution (pet. ether; pet. ether/ether [19:1]; [9:1]) gave a mixture of the starting material phenyltris(trimethylsilyl)silane (PhSi(SiMe₃)₃) **174** and bis(trimethylsilyl)phenylsilane (PhSi(H)(SiMe₃)₂) **217** (0.09 g, 4 % and 3 %, respectively, calculated from NMR). This was followed by the title compound as a colourless oil (0.14 g, 18 %).

- **Method 2**

Dry phenyltris(trimethylsilyl)silane **174** (3.37 g, 10.40 mmol) and potassium *tert*-butoxide (1.19 g, 10.61 mmol) were combined under Ar. THF (18 ml) was added and the resulting solution stirred for 2 h after which time it had become bright red.¹³⁰ The THF was evaporated directly using a vacuum manifold and ether (12 + 6 ml) was added. The resulting solution was added *via* canula to a freshly prepared suspension of magnesium bromide (13.52 mmol) in ether (18 ml). The reaction mixture was stirred for 1 h and was then cooled to -78 °C. Freshly distilled butyraldehyde (0.98 ml, 10.92 mmol) was added and the mixture stirred for 2 h 45 min. Saturated ammonium chloride solution (36 ml) was added and the mixture allowed to reach RT. The aqueous layer was separated and extracted with ether (3 x 36 ml). The combined organic layers were dried over MgSO₄, filtered, concentrated and dried *in vacuo*. Flash column chromatography, gradient elution (pet. ether; pet. ether/ether [39:1]; [29:1]) gave a mixture of the starting material phenyltris(trimethylsilyl)silane (PhSi(SiMe₃)₃) **174** and bis(trimethylsilyl)phenylsilane

(PhSi(H)(SiMe₃)₂) **217** (1.31 g, 2 % and 47 %, respectively, calculated from NMR). This was followed by the title compound as a colourless oil (1.23 g, 36 %); *R*_f (pet. ether/ether [9:1]) 0.41; *v*_{max} (thin film) 3582 and 3463 (broad, O-H), 3066, 3050, 2955, 2894, 1427, 1245, 1095, 835, 699 cm⁻¹; *δ*_H (400 MHz; CDCl₃) 7.53-7.50 (2 H, m, Ar-*H*), 7.34-7.31 (3 H, m, Ar-*H*), 4.09 (1 H, dd, *J* 11.0, 2.5, Si-C-*H*), 1.82-1.57 (3 H, m, 3'-*HH* and 2'-*H*₂), 1.37 (1 H, m, 3'-*HH*), 0.94 (3 H, t, *J* 7.0, 4'-*H*₃), 0.23 (9 H, s, Si(CH₃)₃), 0.22 (9 H, s, Si(CH₃)₃); *δ*_C (100 MHz; CDCl₃) 135.65 (*meta* Ar), 135.37 (*ipso* Ar), 128.18 (*para* Ar), 127.95 (*ortho* Ar), 65.39 (1'-C), 38.80 (2'-C), 20.44 (3'-C), 13.78 (4'-C), 0.28 (Si(CH₃)₃), 0.14 (Si(CH₃)₃); *m/z* (CI) 342 (M+NH₄⁺, 100 %), 325 (M+H⁺, 91 %), 308 (M+H⁺-OH, 72 %), 247 (34 %), 237 (45 %), 209 (16 %), 194 (16 %), 152 (28 %), 135 (20 %); HRMS (CI) Found: 342.2099 (C₁₆H₃₆NOSi₃ (M+NH₄⁺) requires 342.2103).

1,1,1,3,3,3-hexamethyl-2-phenyl-2-(1'-hydroxy-1'-cyclohexylmethyl)trisilane **229**

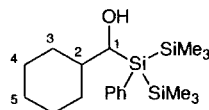

Methyl lithium (1.6 M solution in ether, 4.8 ml, 7.7 mmol) was added to a stirred solution of phenyltris(trimethylsilyl)silane **174** (2.39 g, 7.38 mmol) in THF (14 ml) at 0 °C. This was allowed to warm to RT and stirred for 16 h to produce a dark red solution of the silyl anion. The THF was evaporated directly using a vacuum manifold and ether (10 + 4 ml) was added. The resulting solution was added *via* canula to a suspension of magnesium bromide diethyl etherate (2.67 g, 10.33 mmol) in ether (14 ml). After becoming a homogeneous solution, the reaction mixture was stirred for 1 h and was then cooled to -78 °C.¹⁰ Cyclohexanecarboxaldehyde (1.34 ml, 11.07 mmol) (Kugelrohr distilled immediately prior to use) was added dropwise. The reaction was then stirred for 19 h. Saturated ammonium chloride solution (20 ml) was added and the mixture allowed to reach RT. The aqueous layer was separated and extracted with ether (3 x 20 ml). The combined organic layers were dried over MgSO₄, filtered, concentrated and dried *in vacuo*. Flash column chromatography (pet. ether/ether [100:1]) gave a mixture of the starting material phenyltris(trimethylsilyl)silane (PhSi(SiMe₃)₃) **174** and bis(trimethylsilyl)phenylsilane (PhSi(H)(SiMe₃)₂) **217** (0.48 g, 14 % and 8 %, respectively, calculated from NMR). This was followed by the title compound as a colourless oil (1.02g, 38 %); *R*_f (pet. ether/ether [9:1]) 0.56; *v*_{max} (thin film) 3591 and 3473 (broad, O-H), 3066, 3049, 2925, 2896, 2851, 1448, 1427, 1245, 835 cm⁻¹; *δ*_H (400 MHz; CDCl₃) 7.53-7.50 (2 H, m, Ar-*H*), 7.30-7.29 (3 H, m, Ar-*H*), 3.86 (1 H, d, *J* 7.2, Si-C-*H*), 1.99-0.98 (11 H, m, -(CH₂)₅-CH-), 0.24 (9 H, s, Si(CH₃)₃), 0.21 (9 H, s, Si(CH₃)₃); *δ*_C (100 MHz; CDCl₃) 136.57 (*ipso* Ar), 135.52 (Ar),

128.00 (*Ar*), 127.84 (*Ar*), 71.63 (Si-CH), 44.64 (2-C), 31.35 (-(CH₂)₅-), 30.44 (-(CH₂)₅-), 26.42 (-(CH₂)₅-), 26.30 (-(CH₂)₅-), 26.17 (-(CH₂)₅-), 0.43 (Si(CH₃)₃), 0.18 (Si(CH₃)₃); *m/z* (CI) 365 (M+H⁺, 2 %), 349 (M⁺-Me, 60 %), 291 (M⁺-SiMe₃, 41 %), 274 (29 %), 259 (71 %), 251 (PhSi(SiMe₃)₃⁺, 54 %), 215 (34 %), 200 (35 %), 195 (53 %), 190 (46 %), 177 (35 %), 135 (71 %); HRMS (ES⁺) Found: 387.1982 (C₁₉H₃₆NaOSi₃ (M+Na⁺) requires 387.1972).

1,1,1,3,3,3-hexamethyl-2-phenyl-2-(1'-hydroxyethyl)trisilane 230

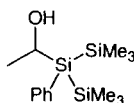

Methylolithium (1.6 M solution in ether, 5.8 ml, 9.3 mmol) was added to a stirred solution of phenyltris(trimethylsilyl)silane **174** (3.00 g, 9.3 mmol) in THF (18 ml) at 0 °C. This was allowed to warm to RT and stirred for 17 h to produce a dark red solution of the silyl anion. The THF was evaporated directly using a vacuum manifold and ether (14 + 4 ml) was added. The resulting solution was added *via* canula to a suspension of magnesium bromide diethyl etherate (3.35 g, 12.96 mmol) in ether (18 ml). After becoming a homogeneous solution, the reaction mixture was stirred for 1 h and was then cooled to -78 °C.¹⁰ Acetaldehyde (0.8 ml, 13.9 mmol) (distilled from CaSO₄ immediately prior to use) was added dropwise. The reaction was then stirred for 18 h. Saturated ammonium chloride solution (25 ml) was added and the mixture allowed to reach RT. The aqueous layer was separated and extracted with ether (3 x 25 ml). The combined organic layers were dried over MgSO₄, filtered, concentrated and dried *in vacuo*. Flash column chromatography (pet. ether/ether [19:1]) gave a mixture of the starting material phenyltris(trimethylsilyl)silane (PhSi(SiMe₃)₃) **174** and bis(trimethylsilyl)phenylsilane (PhSi(H)(SiMe₃)₂) **217** (0.86 g, 12 % and 21 %, respectively, calculated from NMR). This was followed by the title compound as a colourless oil (1.33g, 49 %); *R_f* (pet. ether/ether [9:1]) 0.19; *v*_{max} (thin film) 3441 (broad, O-H), 3067, 2950, 2893, 1427, 1245, 1049, 1068, 1029, 835 cm⁻¹; *δ*_H (500 MHz; CDCl₃) 7.54-7.52 (2 H, m, *Ar-H*), 7.33-7.32 (3 H, m, *Ar-H*), 4.24 (1 H, q, *J* 7.5, *CHOH*), 1.49 (3 H, d, *J* 7.5, *CH₃-COH*), 0.25 (9 H, s, Si(CH₃)₃), 0.21 (9 H, s, Si(CH₃)₃); *δ*_C (126 MHz; CDCl₃) 135.64 (*Ar*), 135.18 (*ipso Ar*), 128.23 (*Ar*), 127.99 (*Ar*), 61.52 (Si-CH), 22.79 (CH₃-COH), 0.31 (Si(CH₃)₃), 0.01 (Si(CH₃)₃); *m/z* (ES⁺) 319 (M+Na⁺, 100 %); HRMS (ES⁺) Found: 314.1786 (C₁₄H₃₂NOSi₃ (M+NH₄⁺) requires 314.1792).

1,1,1,3,3,3-hexamethyl-2-phenyl-2-(1'-hydroxy-2'-methylbutyl)trisilane 231

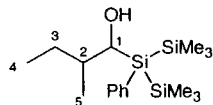

◦ **Method 1**

Methylolithium (1.6 M solution in ether, 6.8 ml, 10.9 mmol) was added to a stirred solution of phenyltris(trimethylsilyl)silane **174** (3.36 g, 10.37 mmol) in THF (18 ml) at 0 °C. This was allowed to warm to RT and stirred for 17 h to produce a dark red solution of the silyl anion. The THF was evaporated directly using a vacuum manifold and ether (15 + 3 ml) was added. The resulting solution was added *via* canula to a suspension of magnesium bromide diethyl etherate (3.75 g, 14.5 mmol) in ether (18 ml). After becoming a homogeneous solution, the reaction mixture was stirred for 1 h and was then cooled to -78 °C.¹⁰ 2-methylbutyraldehyde (1.66 ml, 15.6 mmol) (brand new bottle) was added dropwise. The reaction was then stirred for 26 h. Saturated ammonium chloride solution (30 ml) was added and the mixture allowed to reach RT. The aqueous layer was separated and extracted with ether (3 x 30 ml). The combined organic layers were dried over MgSO₄, filtered, concentrated and dried *in vacuo*. Flash column chromatography, gradient elution (pet. ether; pet. ether/ether [29:1]; [19:1]) gave a mixture of the starting material phenyltris(trimethylsilyl)silane (PhSi(SiMe₃)₃) **174** and bis(trimethylsilyl)phenylsilane (PhSi(H)(SiMe₃)₂) **217** (1.02 g, 12 % and 24 %, respectively, calculated from NMR). This was followed by the title compound as a colourless oil (1.84g, 52 %, 2.4:1 mixture of diastereoisomers).

• **Method 2**

Dry phenyltris(trimethylsilyl)silane **174** (3.34 g, 10.31 mmol) and potassium *tert*-butoxide (1.18 g, 10.51 mmol) were combined under Ar. THF (18 ml) was added and the resulting solution stirred for 2 h after which time it had become bright red.¹³⁰ The THF was evaporated directly using a vacuum manifold and ether (12 + 6 ml) was added. The resulting solution was added *via* canula to a freshly prepared suspension of magnesium bromide (13.40 mmol) in ether (18 ml). The reaction mixture was stirred for 1 h and was then cooled to -78 °C. Freshly distilled 2-methylbutyraldehyde (1.16 ml, 10.83 mmol) was added and the mixture stirred for 2 h 45 min. Saturated ammonium chloride solution (36 ml) was added and the mixture allowed to reach RT. The aqueous layer was separated and extracted with ether (3 x 36 ml). The combined organic layers were dried over MgSO₄, filtered, concentrated and dried *in vacuo*. Flash column chromatography, gradient elution (pet. ether; pet. ether/ether [39:1]; [29:1]) gave a mixture of the starting material

phenyltris(trimethylsilyl)silane (PhSi(SiMe₃)₃) **174** and bis(trimethylsilyl)phenylsilane (PhSi(H)(SiMe₃)₂) **217** (1.18 g, 11 % and 30 %, respectively, calculated from NMR). This was followed by the title compound as a colourless oil (2.02 g, 58 %); R_f (pet. ether/ether [9:1]) 0.61; ν_{max} (thin film) 3594 and 3472 (broad, O-H), 3067, 2959, 2893, 2875, 1461, 1427, 1245, 1093, 835 cm⁻¹; δ_H (300 MHz; CDCl₃) 7.56-7.51 (2.8 H, m, Ar-H), 7.32-7.29 (4.2 H, m, Ar-H), 4.01 (1 H, d, J 5.0, CHOH), 3.89 (0.4 H, d, J 5.0, CHOH*), 1.79-1.63 (1.8 H, m, 2-H, 2-H* and 3-HH*), 1.43 (1 H, m, 3-HH), 1.30-1.11 (1.4 H, m, 3-HH and 3-HH*), 0.95 (3 H, d, J 7.0, 5-H₃), 0.88 (3 H, t, J 7.5, 4-H₃), 0.86 (1.2 H, t, J 7.0, 4-H₃*), 0.86 (1.2 H, d, J 7.0, 5-H₃*), 0.24 (3.6 H, s, Si(CH₃)₃*), 0.23 (9 H, s, Si(CH₃)₃), 0.22 (9 H, s, Si(CH₃)₃), 0.21 (3.6 H, s, Si(CH₃)₃*); δ_C (100 MHz; CDCl₃) 136.56 (*ipso* Ar*), 136.40 (*ipso* Ar), 135.75 (Ar), 135.60 (Ar*), 128.07 (Ar and Ar*), 127.87 (Ar*), 127.84 (Ar), 71.44 (Si-CH*), 70.10 (Si-CH), 41.00 (2-C and 2-C*), 27.42 (3-C), 25.94 (3-C*), 17.17 (5-C*), 16.49 (5-C), 11.97 (4-C), 11.16 (4-C*), 0.50 (Si(CH₃)₃*), 0.36 (Si(CH₃)₃), 0.27 (Si(CH₃)₃), 0.23 (Si(CH₃)₃*); *m/z* (CI) 356 (M+NH₄⁺, 50 %), 338 (M+NH₄⁺-OH₂, 90 %), 268 (42 %); HRMS (CI) Found: 356.2266 (C₁₇H₃₈NOSi₃ (M+NH₄⁺) requires 356.2261).

* Data due to minor diastereoisomer.

1,1,1,3,3,3-hexamethyl-2-phenyl-2-(1'-hydroxy-2',2'-dimethylpropyl)trisilane **232**

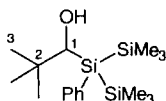

Dry phenyltris(trimethylsilyl)silane **174** (3.15 g, 9.72 mmol) and potassium *tert*-butoxide (1.15 g, 10.21 mmol) were combined under Ar. THF (18 ml) was added and the resulting solution stirred for 2.75 h after which time it had become bright red.¹³⁰ The THF was evaporated directly using a vacuum manifold and ether (15 + 3 ml) was added. The resulting solution was added *via* canula to a suspension of magnesium bromide diethyl etherate (3.26 g, 12.64 mmol) in ether (18 ml). The reaction mixture was stirred for 1 h and was then cooled to -78 °C. Freshly distilled trimethylacetaldehyde (1.11 ml, 10.21 mmol) was added and the mixture stirred for 18 h. Saturated ammonium chloride solution (18 ml) was added and the mixture allowed to reach RT. The aqueous layer was separated and extracted with ether (3 x 18 ml). The combined organic layers were dried over MgSO₄, filtered, concentrated and dried *in vacuo*. Flash column chromatography, gradient elution (pet. ether; pet. ether/ether [29:1]; [19:1]) gave a mixture of the starting material phenyltris(trimethylsilyl)silane (PhSi(SiMe₃)₃) **174** and bis(trimethylsilyl)phenylsilane (PhSi(H)(SiMe₃)₂) **217** (0.38 g, 2 % and 13 %, respectively, calculated from NMR). This was followed by the title compound as a colourless oil (1.22 g, 37 %); R_f (pet. ether/ether [9:1]) 0.66; ν_{max} (thin film) 3477 (broad, O-H), 3067, 3050, 2951, 2896, 2867, 2813, 1476,

1463, 1427, 1393, 1363, 1245, 1093, 975, 835, 699, 689 cm^{-1} ; δ_{H} (300 MHz; CDCl_3) 7.55-7.52 (2 H, m, Ar-*H*), 7.30-7.27 (3 H, m, Ar-*H*), 3.83 (1 H, d, *J* 6.0, CHOH), 1.30 (1 H, d, *J* 6.0, O-*H*), 0.92 (9 H, s, $\text{C}(\text{CH}_3)_3$), 0.30 (9 H, s, $\text{Si}(\text{CH}_3)_3$), 0.21 (9 H, s, $\text{Si}(\text{CH}_3)_3$); δ_{C} (101 MHz; CDCl_3) 137.03 (*ipso*-Ar), 136.06 (*meta*-Ar), 128.14 (*para*-Ar), 127.85 (*ortho*-Ar), 77.19 (CHOH), 36.64 ($\text{C}(\text{CH}_3)_3$), 28.05 ($\text{C}(\text{CH}_3)_3$), 1.02 ($\text{Si}(\text{CH}_3)_3$), 0.43 ($\text{Si}(\text{CH}_3)_3$); *m/z* (CI) 356 ($\text{M}+\text{NH}_4^+$, 15 %), 338 (M^+ , 7 %), 321 (M^+-OH , 100 %), 268 (12 %), 250 (14 %), 233 (20 %), 208 (30 %), 191 (44 %).

Trimethylacetylbis(trimethylsilyl)phenylsilane 234

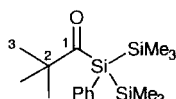

Dry phenyltris(trimethylsilyl)silane **174** (0.86 g, 2.66 mmol) and potassium *tert*-butoxide (0.31 g, 2.79 mmol) were combined under Ar. THF (5 ml) was added and the resulting solution stirred for 2.5 h after which time it had become bright red.¹³⁰ The THF was evaporated directly using a vacuum manifold and ether (4 + 1 ml) was added. The resulting solution was added *via* canula to a suspension of magnesium bromide diethyl etherate (0.89 g, 3.45 mmol) in ether (5 ml). The reaction mixture was stirred for 1.5 h.. Freshly distilled trimethylacetaldehyde (0.30 ml, 2.79 mmol) was added at RT and the mixture stirred for 3 h. Saturated ammonium chloride solution (10 ml) was added and the mixture allowed to reach RT. The aqueous layer was separated and extracted with ether (3 x 10 ml). The combined organic layers were dried over MgSO_4 , filtered, concentrated and dried *in vacuo*. Flash column chromatography, gradient elution (pet. ether; pet. ether/ether [29:1]; [19:1]) gave a mixture of the starting material phenyltris(trimethylsilyl)silane ($\text{PhSi}(\text{SiMe}_3)_3$) **174** and bis(trimethylsilyl)phenylsilane ($\text{PhSi}(\text{H})(\text{SiMe}_3)_2$) **217** (0.18 g, 1 % and 26 %, respectively, calculated from NMR). This was followed by the title compound as a colourless oil (0.32 g, 36 %); R_f (pet. ether/ether [9:1]) 0.95; ν_{max} (thin film) 3068, 3051, 2959, 2952, 2896, 1619 (C=O), 1475, 1427, 1361, 1245, 1093, 942, 857, 836, 699 cm^{-1} ; δ_{H} (500 MHz; CDCl_3) 7.61-7.58 (2 H, m, Ar-*H*), 7.35-7.34 (3 H, m, Ar-*H*), 0.95 (9 H, s, $\text{C}(\text{CH}_3)_3$), 0.25 (18 H, s, $\text{Si}(\text{Si}(\text{CH}_3)_3)_2$); δ_{C} (126 MHz; CDCl_3) 199.32 (C=O), 136.86 (Ar), 135.37 (Ar), 128.76 (Ar), 128.09 (Ar), 50.28 ($\text{C}(\text{CH}_3)_3$), 24.99 ($\text{C}(\text{CH}_3)_3$), 0.33 ($\text{Si}(\text{CH}_3)_3$); *m/z* (CI) 321 (M^+-Me , 8 %), 297 (9 %), 279 (M^+-tBu , 6 %), 257 (18 %), 241 (25 %), 226 (54 %), 209 (39 %), 208 (38 %), 191 (33 %), 179 (18 %), 166 (83 %).

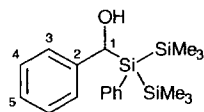
1,1,1,3,3,3-hexamethyl-2-phenyl-2-(1'-hydroxy-1'-phenylmethyl)trisilane 236¹⁰

Dry phenyltris(trimethylsilyl)silane **174** (3.48 g, 10.75 mmol) and potassium *tert*-butoxide (1.23 g, 10.96 mmol) were combined under Ar. THF (19 ml) was added and the resulting solution stirred for 2 h after which time it had become bright red. The THF was evaporated directly using a vacuum manifold and ether (10 + 9 ml) was added. The resulting solution was added *via* canula to a freshly prepared suspension of magnesium bromide (13.98 mmol) in ether (19 ml). The reaction mixture was stirred for 1 h and was then cooled to $-78\text{ }^{\circ}\text{C}$. Freshly distilled benzaldehyde (1.15 ml, 11.29 mmol) was added and the mixture stirred for 3 h. Saturated ammonium chloride solution (40 ml) was added and the mixture allowed to reach RT. The aqueous layer was separated and extracted with ether (3 x 40 ml). The combined organic layers were dried over MgSO_4 , filtered, concentrated and dried *in vacuo*. Flash column chromatography, gradient elution (pet. ether; pet. ether/ether [39:1]; [29:1]) gave a mixture of the starting material phenyltris(trimethylsilyl)silane ($\text{PhSi}(\text{SiMe}_3)_3$) **174** and bis(trimethylsilyl)phenylsilane ($\text{PhSi}(\text{H})(\text{SiMe}_3)_2$) **217** (0.36 g, 4 % and 9 %, respectively, calculated from NMR). This was followed by the title compound as a yellow crystalline solid (2.41 g, 63 %); R_f (pet. ether/ether [9:1]) 0.56; v_{max} (KBr disc) 3538, 3428 (broad, O-H), 3066, 3050, 3024, 2946, 2890, 1594, 1488, 1447, 1426, 1398, 1243, 1189, 1093, 1004, 840, 763, 734, 699 cm^{-1} ; δ_{H} (300 MHz; CDCl_3) 7.47 (2 H, m, Ar-H), 7.27 (2 H, m, Ar-H), 7.16 (3 H, m, Ar-H), 7.07 (3 H, m, Ar-H), 5.11 (1 H, s, CHOH), 0.06 (9 H, s, $\text{Si}(\text{CH}_3)_3$), 0.02 (9 H, s, $\text{Si}(\text{CH}_3)_3$); δ_{C} (126 MHz; CDCl_3) 145.50 (*ipso*-C-Ar), 136.21 (*meta*-Si-Ar), 135.15 (*ipso*-Si-Ar), 128.49 (*para*-Si-Ar), 128.23 (*ortho* or *meta*-C-Ar), 127.93 (*ortho*-Si-Ar), 125.98 (*para*-C-Ar), 125.08 (*ortho* or *meta*-C-Ar), 69.70 (CHOH), 0.15 ($\text{Si}(\text{CH}_3)_3$), 0.01 ($\text{Si}(\text{CH}_3)_3$); m/z (CI) 376 ($\text{M}+\text{NH}_4^+$, 8 %), 358 (M^+ , 100 %), 341 ($\text{M}^+\text{-OH}$, 33 %), 298 (12 %), 281 (31 %), 268 (16 %); all data from which agrees with that given by Griffiths.

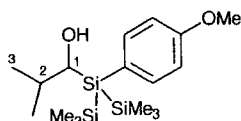
1,1,1,3,3,3-hexamethyl-2-*p*-methoxyphenyl-2-(1'-hydroxy-2'-methylpropyl)trisilane 237

Dry *p*-methoxyphenyltris(trimethylsilyl)silane (3.96 g, 11.19 mmol) and potassium *tert*-butoxide (1.32 g, 11.75 mmol) were combined under Ar. THF (21 ml) was added and the resulting solution stirred for 2 h after which time it had become bright red.¹³⁰ The THF was

evaporated directly using a vacuum manifold and ether (15 + 6 ml) was added. The resulting solution was added *via* canula to a suspension of magnesium bromide diethyl etherate (3.76 g, 14.54 mmol) in ether (21 ml). The reaction mixture was stirred for 1 h and was then cooled to $-78\text{ }^{\circ}\text{C}$. Freshly distilled isobutyraldehyde (1.07 ml, 11.75 mmol) was added and the mixture stirred for 2 h (after which time GC showed the reaction to have ceased although not complete. Saturated ammonium chloride solution (30 ml) was added and the mixture allowed to reach RT. The aqueous layer was separated and extracted with ether (3 x 30 ml). The combined organic layers were dried over MgSO_4 , filtered, concentrated and dried *in vacuo*.

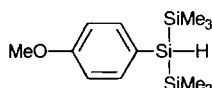

Flash column chromatography, gradient elution (pet. ether/ether [19:1]; [9:1]) gave bis(trimethylsilyl)-*p*-methoxyphenylsilane (1.49 g, 47 %); R_f (pet. ether/ether [9:1]) 0.89; ν_{\max} (thin film) 3079, 3059, 3017, 3001, 2951, 2893, 2834, 2067 (Si-H), 1593, 1497, 1276, 1245, 1180, 1099, 1034, 837 cm^{-1} , δ_H (500 MHz; CDCl_3) 7.35 (2 H, d, J 8.5, Ar-*H*), 6.85 (2 H, d, J 8.5, Ar-*H*), 3.83 (1 H, s, Si-*H*), 3.80 (3 H, s, O- CH_3), 0.18 (18 H, s, $\text{Si}(\text{CH}_3)_3$); δ_C (126 MHz; CDCl_3) 159.72 (MeO-*C*), 137.08 (Ar), 123.90 (Si-*C*), 113.74 (Ar), 54.91 (OCH₃), -0.18 ($\text{Si}(\text{CH}_3)_3$); m/z (GCMS, EI) 282 (M^+ , 61 %), 267 (M^+ -Me, 68 %), 209 (M^+ - SiMe_3 , 62 %), 208 (M^+ - SiMe_3 -H, 86 %), 207 (54 %), 194 (M^+ - SiMe_3 -Me, 64 %), 193 (M^+ - SiMe_3 -H-Me, 100 %), 179 (49 %), 165 (87 %), 163 (69 %), 151 (30 %), 149 (25 %), 135 (70 %).

This was followed by the title compound **237** as a colourless oil (1.27 g, 32 %); R_f (pet. ether/ether [9:1]) 0.32; ν_{\max} (thin film) 3558, 3476 (broad, O-H), 2954, 2893, 2835, 1591, 1499, 1274, 1244, 1181, 1095, 1033, 836 cm^{-1} ; δ_H (500 MHz; CDCl_3) 7.44 (2 H, d, J 9.0, Ar-*H*), 6.87 (2 H, d, J 9.0, Ar-*H*), 3.80 (3 H, s, O- CH_3), 3.74 (1 H, d, J 6.5, CHOH), 1.94 (1 H, oct, J 6.5, $\text{CH}(\text{CH}_3)_2$), 0.98 (3 H, d, J 6.5, $\text{CH}(\text{CH}_3)_2$), 0.88 (3 H, d, J 6.5, $\text{CH}(\text{CH}_3)_2$), 0.23 (9 H, s, $\text{Si}(\text{CH}_3)_3$), 0.20 (9 H, s, $\text{Si}(\text{CH}_3)_3$); δ_C (126 MHz; CDCl_3) 159.73 (MeO-*C*), 137.01 (Ar), 126.42 (Si-Ar), 113.75 (Ar), 72.45 (CHOH), 54.89 (OCH₃), 34.54 ($\text{CH}(\text{CH}_3)_2$), 21.17 ($\text{CH}(\text{CH}_3)_2$), 19.82 ($\text{CH}(\text{CH}_3)_2$), 0.46 ($\text{Si}(\text{CH}_3)_3$), 0.23 ($\text{Si}(\text{CH}_3)_3$); m/z (CI) 355 ($\text{M}+\text{H}^+$, 1 %), 337 (M^+ -OH, 11 %), 299 (9 %), 281 (M^+ - SiMe_3 , 12 %), 266 (15 %), 264 (M^+ - SiMe_3 -OH, 14 %), 249 (36 %), 208 (M^+ -2 SiMe_3 , 53 %), 191 (M^+ -2 SiMe_3 -OH, 100 %), 165 (24 %).

Trifluoroacetic acid 1-(1',1',1',3',3',3'-hexamethyl-2'-phenyl-trisilan-2'-yl)-2-methylpropyl ester 245

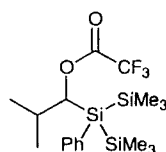

A mixture of silyl-alcohol **182** (0.28 g, 0.85 mmol) and triethylamine (0.18 ml, 1.28 mmol) in dry DCM (16 ml) was cooled to $-10\text{ }^{\circ}\text{C}$. Trifluoroacetic anhydride (0.14 ml, 0.98 mmol) was added dropwise. The solution was warmed to RT and stirred for 17 h. Water (15 ml) was then added. The aqueous layer was separated and extracted with DCM (3 x 15 ml). The combined organic extracts were dried over MgSO_4 , filtered, concentrated and dried *in vacuo*. Filtration through a pad of silica (hexane) gave the title compound as a clear oil (0.26 g, 73 %); R_f (hexane/ether [9:1]) 0.99; ν_{max} (thin film) 2963, 2896, 1777 (C=O), 1428, 1369, 1248, 1216, 1154, 1095, 837, 743, 735, 699 cm^{-1} ; δ_{H} (200 MHz; CDCl_3) 7.50-7.45 (2 H, m, Ar-H), 7.32-7.28 (3 H, m, Ar-H), 5.49 (1 H, d, J 6.8, CHOCOCF_3), 2.15 (1 H, octet, J 6.8, $\text{CH}(\text{Me})_2$), 0.90 and 0.86 (3 H, d, J 6.8, $\text{CH}(\text{CH}_3)_2$), 0.25 and 0.20 (9 H, s, $\text{Si}(\text{CH}_3)_3$); δ_{C} (63 MHz; CDCl_3) 157.75 (q, J 41.2, C=O), 135.56 (Ar), 134.35 (Ar), 128.61 (Ar), 128.04 (Ar), 114.86 (q, J 286.7, CF_3), 79.67 (Si-CH), 33.42 ($\text{CH}(\text{Me})_2$), 20.88 and 19.74 ($\text{CH}(\text{CH}_3)_2$), 0.16 ($\text{Si}(\text{CH}_3)_3$), 0.10 ($\text{Si}(\text{CH}_3)_3$); δ_{F} (188 MHz; CDCl_3) -74.85 (3 F, s, CF_3); m/z (CI) 438 ($\text{M}+\text{NH}_4^+$, 100 %), 342 (3 %), 324 ($\text{M}+\text{H}^+-\text{CF}_3\text{CO}$, 10 %), 308 (4 %), 268 (7 %); HRMS (ES^+) Found: 438.1927 ($\text{C}_{18}\text{H}_{34}\text{F}_3\text{NO}_2\text{Si}_3$ requires 438.1928).

1-Phenyl-1-trimethylsilyl-2-(prop-2'-yl)-3-methylsilacyclohex-4-ene 183

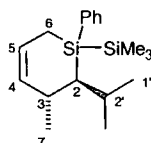

• Method 1¹⁰

Methylolithium (1.6 M solution in ether, 13.0 ml, 20.9 mmol) was added to a stirred solution of silyl alcohol **182** (6.76 g, 20.9 mmol) and 1,3-pentadiene (mixture of *cis* + *trans* isomers, 12.5 ml, 125.2 mmol) in ether (300 ml) at $-78\text{ }^{\circ}\text{C}$. The mixture was allowed to warm to $-30\text{ }^{\circ}\text{C}$ and stirred for 22 h, then to $0\text{ }^{\circ}\text{C}$ and stirred for 8 h. Saturated ammonium chloride solution (200 ml) was added and the mixture allowed to reach RT. The aqueous layer was separated and extracted with ether (3 x 200 ml). The combined organic layers were dried over MgSO_4 , filtered, concentrated and dried *in vacuo*. Flash column chromatography (hexane) gave the title compound as a mixture of diastereoisomers as a colourless oil (3.25 g, 52 %).

o Method 2

n-Butyllithium (1.6 M solution in hexane, 0.58 ml, 0.92 mmol) was added to a stirred solution of silyl alcohol **182** (0.29 g, 0.88 mmol) and 1,3-pentadiene (mixture of *cis* + *trans* isomers, 0.53 ml, 5.28 mmol) in dry ether (10 ml) at RT. The mixture was stirred for 2 h after which time TLC showed complete consumption of starting material. The solution was cooled to $-20\text{ }^{\circ}\text{C}$ and an anhydrous suspension of LiBr in ether (1.75 M, 0.5 ml, 0.88 mmol) was added and seen to go into solution. The mixture was stirred at $-20\text{ }^{\circ}\text{C}$ for 19.5 h after which time saturated ammonium chloride solution (10 ml) was added and the mixture allowed to reach RT. The aqueous layer was separated and extracted with ether (3 x 10 ml). The combined organic layers were dried over MgSO_4 , filtered, concentrated and dried *in vacuo*. Flash column chromatography (pet. ether) gave the title compound as a colourless oil (0.133 g, 50 %) as a mixture of diastereoisomers in a ratio of 83 : 9 : 8 % (ratio of product peak integrals by GC); R_f (hexane) 0.71; ν_{max} (thin film) 3067, 2997, 2958, 2872, 1461, 1396, 1246, 1108, 855, 838, 736, 702 cm^{-1} ; NMR data for major isomer: δ_{H} (200 MHz; CDCl_3) 7.51-7.48 (2 H, m, Ar-*H*), 7.31-7.28 (3 H, m, Ar-*H*), 5.82 (1 H, dtd, J 10.5, 5.2, 1.8, 5-*H*), 5.54 (1 H, dtd, J 10.5, 4.4, 1.8, 4-*H*), 2.36 (1 H, m, 3-*H*), 2.10 (1 H, septet d, J 6.8, 3.3, CH(CH₃)₂), 1.68 (1 H, dtd, J 17.2, 5.2, 1.8, 6-*HH*), 1.47 (1 H, dtd, J 17.2, 5.2, 1.8, 6-*HH*), 1.20 (1 H, dd, J 6.5, 3.3, 2-*H*), 1.03 (3 H, d, J 6.8, CH(CH₃)₂), 0.93 (3 H, d, J 7.2, 7-*H*₃), 0.88 (3 H, d, J 6.8, CH(CH₃)₂), 0.14 (9 H, s, Si(CH₃)₃); δ_{C} (126 MHz; CDCl_3) 139.36 (*ipso*-Ar), 137.41 (4-*C*), 134.48 (Ar), 128.19 (Ar), 127.66 (Ar), 123.56 (5-*C*), 38.21 (2-*C*), 32.77 (3-*C*), 30.02 (2'-*C*), 23.56 (7-*C*), 22.99 (1'-*C*), 22.45 (1'-*C*), 9.74 (6-*C*), -0.55 (Si(CH₃)₃); m/z (EI) 302 (M^+ , 7 %), 259 ($\text{M}^+ - \text{iPr}$, 4 %), 229 ($\text{M}^+ - \text{SiMe}_3$, 56 %), 218 (27 %), 203 (47 %), 185 (11 %), 173 (29 %), 161 (100 %), 145 (31 %), 135 (82 %), 121 (69 %); all data from which agrees with that given by Griffiths.¹⁰

4,6-Dimethyl hept-1-en-5-ol **267**¹⁰

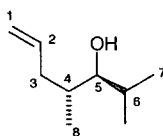

o Stage 1

To a solution of silacycle **183** (1.65 g, 5.46 mmol) in dry chloroform (130 ml) was added trifluoroborane-acetic acid complex (1.7 ml, 12.2 mmol). The mixture was stirred at RT for 30 min after which time saturated sodium hydrogen carbonate solution (60 ml) was added. The aqueous layer was separated and extracted with DCM (3 x 60 ml). The combined organic extracts were dried over MgSO_4 , filtered, concentrated and dried *in vacuo* to give a clear oil which was used immediately in stage 2.

◦ Stage 2

To the clear oil was added potassium hydrogen carbonate (1.05 g, 10.53 mmol) and potassium fluoride (0.63 g, 10.86 mmol). The mixture was dissolved in THF/MeOH solution (1:1, 37 ml) and hydrogen peroxide (35 % w/w solution in water, 6.3 ml, 65.1 mmol) was added. The mixture was heated to reflux and stirred for 18 h. The mixture was then allowed to cool to RT and saturated sodium thiosulfate solution (35 ml) was added together with ethyl acetate (40 ml). The aqueous layer was separated and extracted with ethyl acetate (3 x 40 ml). The combined organic extracts were dried over MgSO₄, filtered and concentrated [High vacuum was not used as it was thought the product may be volatile]. Flash column chromatography (pet. ether/ethyl acetate [9:1]) gave the title compound along with a trace amount of the diastereoisomer as a clear oil (0.34 g, 43 %); R_f (pet. ether/ethyl acetate [9:1]) 0.64; v_{max} (thin film) 3406 (broad, O-H), 3075, 2961, 2874, 1640 (C=C), 1463, 992, 909, 741 cm⁻¹; NMR data for major isomer: δ_H (500 MHz; CDCl₃) 5.82 (1 H, m, 2-*H*), 5.00 (1 H, d, J 17.5, 1-*H*, *cis*), 4.99 (1 H, d, J 10.5, 1-*H*, *trans*), 3.09 (1 H, dd, J 7.0, 5.0, 5-*H*), 2.36 (1 H, dm, J 14.0, 3-*HH*), 1.91 (1 H, ddd, J 14.0, 9.0, 9.0, 3-*HH*), 1.80 (1 H, m, 6-*H*), 1.66 (1 H, m, 4-*H*), 0.93 (3 H, d, J 7.0, CH(CH₃)₂), 0.88 (3 H, d, J 7.0, CH(CH₃)₂), 0.87 (3 H, d, J 7.0, 8-*H*₃); δ_C (126 MHz; CDCl₃) 137.66 (2-*C*), 115.89 (1-*C*), 80.59 (5-*C*), 36.44 (3-*C*), 35.79 (4-*C*), 30.01 (6-*C*), 20.00 (CH(CH₃)₂), 16.16 (8-*C*), 15.87 (CH(CH₃)₂); *m/z* (EI) 124 (M⁺-H₂O, 11 %), 123 (5 %), 110 (5 %), 109 (M⁺-H₂O-Me, 46 %), 108 (12 %), 101 (4 %), 100 (24 %), 99 (M⁺-ⁱPr, 100 %), 98 (32 %); all data from which agrees with that given by Griffiths and published in the literature.^{10, 198}

4,6-Dimethyl-5-oxy(4'-nitrobenzoyl)-hept-1-ene 268

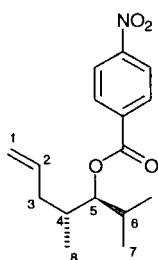

To a solution of alcohol **267** (0.10 g, 0.73 mmol) and DMAP (0.17 g, 1.38 mmol) in THF (20 ml) was added dropwise a solution of *p*-nitrobenzoyl chloride (1.39 g, 7.49 mmol) and triethylamine (1.5 ml, 10.9 mmol) in THF (20 ml).¹⁰ The mixture was stirred at RT for 21 h. Water (20 ml) and ether (20 ml) were then added. The aqueous layer was separated and extracted with ether (3 x 20 ml). The combined organic extracts were dried over MgSO₄, filtered, concentrated and dried *in vacuo*. Flash column chromatography (hexane/ethyl acetate [9:1]) gave the title compound as a thick clear oil along with a trace amount of the diastereoisomer (0.15 g, 73 %); R_f (hexane/ethyl acetate [9:1]) 0.71; v_{max} (thin film) 2967,

2935, 2877, 1722 (C=O), 1607, 1529, 1347, 1272, 1113, 1101, 719 cm^{-1} ; δ_{H} (500 MHz; CDCl_3) 8.29 (2 H, d, J 9.0, Ar-*H*), 8.21 (2 H, d, J 9.0, Ar-*H*), 5.75 (1 H, m, 2-*H*), 5.01-4.94 (3 H, m, 5-*H* and 1-*H*), 2.26 (1 H, m, 3-*HH*), 2.10 (1 H, m, 6-*H*), 1.99 (1 H, m, 4-*H*), 1.91 (1 H, ddd, J 14.0, 7.5, 7.5, 3-*HH*), 0.96 (3 H, d, J 7.0, $\text{CH}(\text{CH}_3)_2$), 0.94 (3 H, d, J 7.0, $\text{CH}(\text{CH}_3)_2$), 0.93 (3 H, d, J 7.0, 8-*H*₃); δ_{C} (126 MHz; CDCl_3) 164.56 (C=O), 150.42 (*ipso*-Ar), 136.53 (2-*C*), 135.84 (*ipso*-Ar), 130.66 (Ar), 123.51 (Ar), 116.38 (1-*C*), 83.59 (5-*C*), 36.27 (3-*C*), 34.45 (4-*C*), 29.38 (6-*C*), 19.69 ($\text{CH}(\text{CH}_3)_2$), 16.76 (8-*C*), 16.09 ($\text{CH}(\text{CH}_3)_2$); *m/z* (CI) 309 ($\text{M}+\text{NH}_4^+$, 100 %), 279 (15 %), 262 (11 %), 248 (4 %), 222 (4 %), 200 (5 %), 150 (21 %), 124 (M^+ -ArCO₂H, 31 %); HRMS (CI) Found: 309.1822 ($\text{C}_{16}\text{H}_{25}\text{N}_2\text{O}_4$ ($\text{M}+\text{NH}_4^+$) requires 309.1814).

1-Phenyl-1-trimethylsilyl-2-(prop-2'-yl)-3-methylsilacyclohexane **184**¹⁰

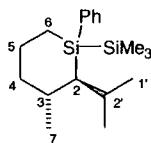

A mixture of silacycle **183** (1.00 g, 3.32 mmol) and Pd on carbon (10 % Pd, approx. 0.01 g) in dry toluene (20 ml) was repeatedly evacuated and flushed with hydrogen from a balloon. The mixture was then stirred under the hydrogen atmosphere for 6 h. It was then filtered through a celite pad and washed through with ether. The filtrate was concentrated and dried *in vacuo*. Flash column chromatography (hexane) gave the title compound as a colourless oil as a mixture of diastereoisomers (0.745 g, 74 %); R_f (hexane) 0.94; v_{max} (thin film) 3067, 2953, 2907, 2870, 1463, 1427, 1259, 1244, 1099, 853, 833, 755, 734, 699 cm^{-1} ; NMR data for major isomer: δ_{H} (500 MHz; CDCl_3) 7.57-7.55 (2 H, m, Ar-*H*), 7.33-7.30 (3 H, m, Ar-*H*), 2.16 (1 H, septet d, J 7.0, 3.8, $\text{CH}(\text{CH}_3)_2$), 1.95 (1 H, dm, J 13.0, 5-*HH*), 1.81 (1 H, m, 3-*H*), 1.74 (1 H, dm, J 13.5, 4-*HH*), 1.50 (1 H, qt, J 13.0, 3.0, 5-*HH*), 1.19 (1 H, m, 4-*HH*), 1.11 (1 H, dd, J 10.0, 3.8, 2-*H*), 1.07 (1 H, m, 6-*HH*), 1.02 (3 H, d, J 7.0, $\text{CH}(\text{CH}_3)_2$), 0.97 (3 H, d, J 6.5, 7-*H*₃), 0.79 (3 H, d, J 7.0, $\text{CH}(\text{CH}_3)_2$), 0.27 (9 H, s, $\text{Si}(\text{CH}_3)_3$); δ_{C} (126 MHz; CDCl_3) 140.62 (*ipso*-Ar), 134.53 (Ar), 128.10 (Ar), 127.61 (Ar), 40.54 (2-*C*), 39.03 (4-*C*), 34.16 (3-*C*), 28.73 (2'-*C*), 23.59 (7-*C*), 23.38 (5-*C*), 23.18 (1'-*C*), 22.53 (1'-*C*), 13.01 (6-*C*), 0.20 ($\text{Si}(\text{CH}_3)_3$); *m/z* (EI) 304 (M^+ , 37 %), 289 (M^+ -Me, 6 %), 231 (M^+ -SiMe₃, 100 %), 203 (5 %), 187 (10 %), 175 (25 %), 161 (33 %), 147 (19 %), 135 (49 %), 121 (65 %), 107 (28 %), 105 (37 %); all data from which agrees with that given by Griffiths.

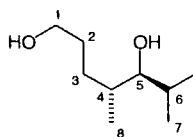
(±)-4(R*),6-Dimethyl-heptane-1,5(S*)-diol 186¹⁰

- **Stage 1**

To a solution of silacycle **184** (0.75 g, 2.45 mmol) in dry chloroform (28 ml) was added trifluoroborane-acetic acid complex (6.8 ml, 49.0 mmol). The mixture was then heated to reflux and stirred for 18 h. The solution was then allowed to cool to RT and saturated sodium hydrogen carbonate solution (40 ml) was added. The aqueous layer was separated and extracted with DCM (3 x 40 ml). The combined organic layers were then dried over MgSO₄, filtered, concentrated and dried *in vacuo* to give a dark orange oil which was used immediately in stage 2.

- **Stage 2**

To the dark orange oil was added potassium hydrogen carbonate (0.94 g, 9.43 mmol) and potassium fluoride (0.57 g, 9.75 mmol). The mixture was dissolved in THF/MeOH solution (1:1, 19 ml) and hydrogen peroxide (35 % w/w solution in water, 5.8 ml, 58.4 mmol) was added. The mixture was heated to reflux and stirred for 19 h. The mixture was then allowed to cool to RT and saturated sodium thiosulfate solution (19 ml) was added together with ethyl acetate (30 ml). The aqueous layer was separated and extracted with ethyl acetate (3 x 30 ml). The combined organic extracts were dried over MgSO₄, filtered, concentrated and dried *in vacuo*. Flash column chromatography (pet. ether/ethyl acetate [1:1]) gave the pure title compound as a colourless oil (0.332 g, 85 %); R_f (pet. ether/ethyl acetate [1:1]) 0.23; ν_{max} (thin film) 3346 (broad, O-H), 2959, 2932, 2872, 1465, 1054, 989, 971 cm⁻¹; δ_H (500 MHz; CDCl₃) 3.65 (2 H, t, J 5.5, 1-H₂), 3.09 (1 H, t, J 6.5, 5-H), 1.82 (1 H, octet, J 6.5, 6-H), 1.69 (2 H, m, 3-HH and 2-HH), 1.60 (1 H, m, 4-H), 1.50 (1 H, m, 2-HH), 1.18 (1 H, q, J 8.5, 3-HH), 0.93 (3 H, d, J 6.5, CH(CH₃)₂), 0.90 (3 H, d, J 6.5, 8-H₃), 0.89 (3 H, d, J 6.5, CH(CH₃)₂); δ_C (126 MHz; CDCl₃) 80.96 (5-C), 63.23 (1-C), 35.51 (4-C), 30.86 (2-C), 30.00 (6-C), 27.41 (3-C), 20.05 (CH(CH₃)₂), 16.41 (8-C), 16.00 (CH(CH₃)₂); m/z (ES⁺) 333 (M₂Na⁺, 4 %), 183 (M+Na⁺, 100 %); HRMS (ES) Found: 178.1813 (C₉H₂₄NO₂ (M+NH₄⁺) requires 178.1807); all data from which agrees with that given by Griffiths and published in the literature.¹⁹⁹

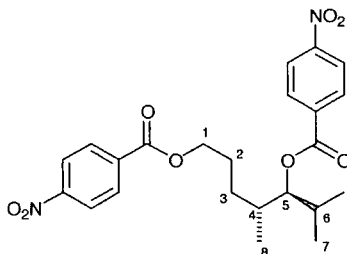
(±)-4(R*)-Dimethyl-heptane-1,5(S*)-dioxybenzoyl ester 269¹⁰

To a solution of diol **186** (0.05 g, 0.34 mmol) and DMAP (0.08 g, 0.64 mmol) in THF (10 ml) was added dropwise a solution of *p*-nitrobenzoyl chloride (0.64 g, 3.46 mmol) and triethylamine (0.7 ml, 5.1 mmol) in THF (10 ml). The mixture was stirred at RT for 21 h. Water (15 ml) and ether (15 ml) were then added. The aqueous layer was separated and extracted with ether (3 x 15 ml). The combined organic extracts were dried over MgSO₄, filtered, concentrated and dried *in vacuo*. Flash column chromatography (hexane/ethyl acetate [9:1]) gave the pure title compound as a thick orange oil (0.07 g, 43 %); R_f (hexane/ethyl acetate [9:1]) 0.33; ν_{\max} (thin film) 2960, 1719 (C=O), 1609, 1527, 1465, 1948, 1314, 1266, 1094, 1012, 875, 841, 786, 717 cm⁻¹; δ_{H} (400 MHz; CDCl₃) 8.25 (2 H, d, J 9.0, Ar-*H*), 8.21 (2 H, d, J 9.0, Ar-*H*), 8.18 (2 H, d, J 9.0, Ar-*H*), 8.11 (2 H, d, J 9.0, Ar-*H*), 4.97 (1 H, dd, J 5.2, 6.8, 5-*H*), 4.33 (2 H, td, J 6.8, 1.6, 1-*H*₂), 2.10 (1 H, octet, J 6.8, 6-*H*), 1.97 (2 H, m, 4-*H* and 2-*HH*), 1.77-1.59 (2 H, m, 2-*HH* and 3-*HH*), 1.31 (1 H, ddt, J 10.0, 9.6, 4.4, 3-*HH*), 1.00 (3 H, d, J 6.8, 8-*H*₃), 0.96 (3 H, d, J 6.8, CH(CH₃)₂), 0.94 (3 H, d, J 6.8, CH(CH₃)₂); δ_{C} (100 MHz; CDCl₃) 164.58 (C=O), 164.55 (C=O), 150.43 (*ipso*-Ar), 150.39 (*ipso*-Ar), 135.62 (*ipso*-Ar), 135.53 (*ipso*-Ar), 130.63 (Ar), 130.50 (Ar), 123.53 (Ar), 123.42 (Ar), 83.61 (5-*C*), 65.86 (1-*C*), 34.18 (4-*C*), 29.31 (6-*C*), 27.67 (3-*C*), 25.85 (2-*C*), 19.74 (CH(CH₃)₂), 16.67 (CH(CH₃)₂), 16.01 (8-*C*); *m/z* (CI) 476 (M+NH₄⁺, 13 %), 391 (14 %), 327 (13 %), 309 (21 %), 279 (40 %), 262 (99 %), 224 (71 %), 201 (7 %), 156 (13 %), 138 (33 %), 137 (37 %), 125 (31 %), 120 (41 %), 109 (25 %); HRMS (CI) Found: 476.2033 (C₂₃H₃₀N₃O₈ (M+NH₄⁺) requires 476.2030).

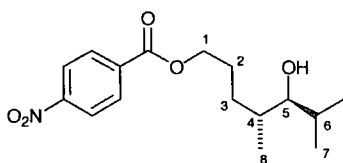

Further elution gave Benzoic acid 5-hydroxy-4,6-dimethyl heptyl ester **270** as a pale brown oil (0.03 g, 26 %); R_f (hexane/ethyl acetate [9:1]) 0.12; ν_{\max} (thin film) 3434 (broad, O-H), 2960, 2923, 1724 (C=O), 1528, 1465, 1350, 1276, 1230, 1103, 719 cm⁻¹; δ_{H} (500 MHz; CDCl₃) 8.29 (2 H, d, J 8.5, Ar-*H*), 8.21 (2 H, d, J 8.5, Ar-*H*), 4.38 (2 H, t, J 6.0, 1-*H*₂), 3.11 (1 H, t, J 5.5, 5-*H*), 1.93 (1 H, m, 2-*HH*), 1.82 (1 H, m, 6-*H*), 1.75 (2 H, m, 3-*HH* and 2-*HH*), 1.63 (1 H, m, 4-*H*), 1.28 (1 H, m, 3-*HH*), 0.94 (6 H, d, J 7.0, 8-*H*₃ and CH(CH₃)₂),

0.90 (3 H, d, J 7.0, CH(CH₃)₂); δ_C (126 MHz; CDCl₃) 164.75 (C=O), 150.47 (*ipso-Ar*), 135.82 (*ipso-Ar*), 130.65 (*Ar*), 123.51 (*Ar*), 80.84 (5-*C*), 66.36 (1-*C*), 35.49 (4-*C*), 30.03 (6-*C*), 27.61 (3-*C*), 26.22 (2-*C*), 19.97 (CH(CH₃)₂), 16.30 (9-*C*), 16.06 (CH(CH₃)₂); *m/z* (CI) 327 (M+NH₄⁺, 100 %), 310 (M+H⁺, 3 %), 292 (M⁺-OH, 34 %), 280 (23 %), 237 (6 %), 207 (2 %), 155 (4 %), 151 (8 %), 150 (8 %), 142 (8 %), 137 (7 %), 125 (58 %), 120 (22 %), 99 (38 %); HRMS (CI) Found: 327.1919 (C₁₆H₂₇N₂O₅ (M+NH₄⁺) requires 327.1920).

5(R*)-Methyl-6(S*)-isopropyl- δ -valerolactone 271

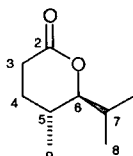

To a solution of diol **186** (0.05 g, 0.32 mmol) in dry DCM (4 ml) was added powdered molecular sieves (4 Å, approx. 0.1 g), NMO (0.15 g, 1.25 mmol) and TPAP (0.03 g, 0.08 mmol).¹⁶⁸⁻¹⁷⁰ The mixture was stirred at RT for 16 h. It was then diluted with ether (8 ml), filtered through silica and washed through with more ether. The filtrate was concentrated under reduced pressure. [High vacuum was not used as the product is volatile]. Flash column chromatography (pet. ether/ether [1:1]) gave the pure title compound as a clear oil along with a small amount of the opposite diastereoisomer in a ratio of 92 : 8 % (ratio of product peak integrals by GC) (0.04 g, 76 %); *R_f* (hexane/ether [1:1]) 0.41; *v*_{max} (thin film) 2966, 2940, 2884, 1738 (C=O), 1468, 1254, 1218, 1007 cm⁻¹; NMR data for the major isomer **271**: δ_H (500 MHz; CDCl₃) 3.80 (1 H, dd, J 10.0, 2.5, 6-*H*), 2.59 (1 H, ddd, J 17.5, 7.0, 4.0, 3-*HH*), 2.43 (1 H, ddd, J 17.5, 10.0, 7.0, 3-*HH*), 1.93 (1 H, septet d, J 7.0, 2.5, 7-*H*), 1.86 (1 H, ddt, J 13.5, 7.0, 4.0, 4_{eq}-*H*), 1.79 (1 H, m, 5-*H*), 1.51 (1 H, dtd, J 13.5, 10.0, 7.0, 4_{ax}-*H*), 1.05 (3 H, d, J 7.0, CH(CH₃)₂), 0.96 (3 H, d, J 7.0, 9-*H*₃), 0.88 (3 H, d, J 7.0, CH(CH₃)₂); δ_C (126 MHz; CDCl₃) 172.13 (C=O), 89.72 (6-*C*), 29.94 (5-*C*), 29.47 (3-*C*), 29.18 (7-*C*), 19.75 (CH(CH₃)₂), 17.13 (9-*C*), 14.18 (CH(CH₃)₂); *m/z* (EI) 156 (M⁺, 24 %), 128 (43 %), 114 (29 %), 113 (100 %), 95 (15 %), 86 (22 %), 85 (81 %), 84 (75 %), 71 (33 %), 69 (38 %), 67 (64 %); all data from which agrees with that given in the literature.¹⁷¹

4-Isobutyl-4-methylbutyrolactone 273¹⁷²

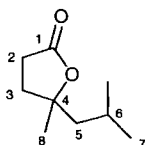

To magnesium turnings (1.03 g, 42.2 mmol) in ether (10 ml) was added dropwise a solution of isobutyl bromide (4.6 ml, 42.2 mmol) in ether (10 ml). After formation of the Grignard

reagent, approximately two-thirds of the ether was distilled from the mixture under nitrogen. To the residue was added dry benzene (10 ml) and the resulting solution was added over 25 min to a solution of ethyl levulinate (5.3 ml, 37 mmol) in dry benzene (15 ml) at 0 °C. The mixture was stirred at 0 °C for another 15 min and then poured onto a mixture of conc. sulfuric acid (10 ml) and ice (approx. 300 g). The mixture was extracted with ether (3 x 150 ml) and the combined extracts were washed with water (200ml) followed by aqueous sodium hydrogen carbonate solution (5 %, 200 ml) and then dried over MgSO₄, filtered and concentrated under reduced pressure. The resulting clear oil was purified by flash chromatography (pet. ether/ ether [6:4]) followed by vacuum distillation to give the title compound as a clear oil (2.95 g, 51 %); R_f (pet. ether/ether) 0.43; b.p. 101-105 °C @ 0.15 mm Hg (lit. 110 °C @0.5 mm Hg)¹⁷²; ν_{\max} (thin film) 2957, 2872, 1770 (C=O), 1466, 1382, 1229, 1207, 1162, 1135, 939 cm⁻¹; δ_{H} (500 MHz; CDCl₃) 2.56 (2 H, m, 2-*H*₂), 2.08-1.95 (2 H, m, 3-*H*₂), 1.79 (1 H, nonet, J 7.0, 6-*H*), 1.56 (2 H, dd, J 6.5, 6.5, 5-*H*₂), 1.36 (3 H, s, 8-*H*₃), 0.95 (3 H, d, J 7.0, CH(CH₃)₂), 0.92 (3 H, d, J 7.0, CH(CH₃)₂); δ_{C} (126 MHz; CDCl₃) 176.75 (C=O), 87.06 (4-*C*), 49.38 (5-*C*), 34.14 (3-*C*), 28.86 (2-*C*), 25.38 (8-*C*), 24.35 (6-*C*), 24.16 (CH(CH₃)₂) 23.89 (CH(CH₃)₂); *m/z* (EI) 156 (M⁺, 8 %), 141 (M⁺-Me, 63 %), 101 (50 %), 100 (49 %), 99 (100 %); all data from which agrees with that given in the literature.²⁰⁰

3-Methyl-2-isopropyl-2-cyclopenten-1-one 274¹⁷²

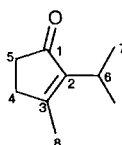

To a solution of P₂O₅ in H₃PO₄ (85 % aqueous solution, 14 ml) at 60 °C was added lactone 273. The mixture was heated to 98 °C and stirred for 5.5 h after which time the solution was poured on to ice (approx. 150 g). The mixture was extracted with ether (4 x 200 ml) and the combined extracts were washed with water (200 ml), dried over MgSO₄, filtered and concentrated [High vacuum was not used as the product is volatile]. Flash column chromatography, gradient elution (pet. ether/ether [9:1], [5:1]) gave the title compound as a clear oil (1.88 g, 72 %); R_f (pet. ether/ether [9:1]) 0.23; ν_{\max} (thin film) 2961, 2930, 2872, 1695 (C=O), 1637, 1458, 1439, 1385, 1340, 1297, 1271, 1116, 967 cm⁻¹; δ_{H} (500 MHz; CDCl₃) 2.75 (1 H, septet, J 7.0, 6-*H*), 2.41 (2 H, m, 5-*H*₂), 2.27 (2 H, m, 4-*H*₂), 2.02 (3 H, s, 8-*H*₃), 1.12 (6 H, d, J 7.0, 7-*H*₃); δ_{C} (126 MHz; CDCl₃) 209.36 (C=O), 168.78 (3-*C*), 144.53 (2-*C*), 34.46 (4-*C*), 31.59 (5-*C*), 24.63 (6-*C*), 20.17 (7-*C*); *m/z* (EI) 138 (M⁺, 91 %), 123 (M⁺-Me, 100 %), 110 (64 %), 95 (41 %), 81 (33 %), 67 (48 %); all data from which agrees with that given in the literature.²⁰¹

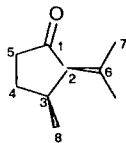
(±)-3(S*)-Methyl-2(S*)-isopropylcyclopentanone 275^{172, 202}

To a solution of pentenone **274** (1.80 g, 13.04 mmol) in dry hexane (360 ml) were added powdered sodium carbonate (4.60 g, 43.43 mmol) and rhodium on carbon (5 %, 0.6 g). The mixture was shaken vigorously under hydrogen (14-25 psi) in a Parr apparatus at RT for 23 h. The mixture was then filtered through celite, washed through with ether and then concentrated. Vacuum distillation gave the title compound as a clear oil (0.91 g, 50 %); b.p. 155 °C @ 27-28 mbar; ν_{\max} (thin film) 2958, 2876, 1738 (C=O), 1464, 1386, 1364, 1156, 996 cm^{-1} ; δ_{H} (500 MHz; CDCl_3) 2.48 (1 H, m, 3-*H*), 2.17 (2 H, m, 5-*H*₂), 1.95 (1 H, m, 4-*HH*), 1.88 (1 H, t, *J* 7.0, 2-*H*), 1.75 (1 H, octet, *J* 7.0, 6-*H*), 1.65 (1 H, m, 4-*HH*), 1.11 (3 H, d, *J* 7.0, $\text{CH}(\text{CH}_3)_2$), 0.91 (3 H, d, *J* 7.0, $\text{CH}(\text{CH}_3)_2$), 0.87 (3 H, d, *J* 7.0, 8-*H*₃); δ_{C} (126 MHz; CDCl_3) 60.53 (2-*C*), 35.25 (5-*C*), 33.13 (3-*C*), 27.66 (4-*C*), 25.29 (6-*C*), 21.73 ($\text{CH}(\text{CH}_3)_2$), 21.07 ($\text{CH}(\text{CH}_3)_2$), 14.55 (8-*C*); *m/z* (EI) 140 (M^+ , 70 %), 125 (M^+ -Me, 26 %), 111 (46 %), 98 (79 %), 96 (68 %), 83 (100 %); all data from which agrees with that given in the literature.

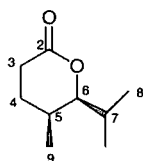
(±)-5(S*)-Methyl-6(S*)-isopropyl- δ -valerolactone 276¹⁷²

To a solution of ketone **275** (0.91 g, 6.50 mmol) in hexane (95 ml) was added sodium hydrogen carbonate (3.82 g, 45.50 mmol). The mixture was stirred at -4 °C and a solution of *m*-chloroperoxybenzoic acid (57 % w/w, 5.9 g) in DCM (45 ml) was added over 15 min. The mixture was stirred at 0 °C for 74 h, was then filtered over celite, washed through with pet. ether and concentrated. Flash column chromatography (pet. ether/ethyl acetate [9:1]) gave the title compound as a clear oil (0.41 g, 41 %); *R_f* (pet. ether/ethyl acetate [4:1]) 0.48; ν_{\max} (thin film) 2965, 2944, 2880, 1738 (C=O), 1472, 1386, 1370, 1362, 1330, 1245, 1210, 1183, 1124, 1068, 1008, 987 cm^{-1} ; δ_{H} (500 MHz; CDCl_3) 3.82 (1 H, dd, *J* 10.0, 2.5, 6-*H*), 2.49 (2 H, m, 3-*H*₂), 2.15 (1 H, m, 5-*H*), 2.02 (1 H, dtd, *J* 14.0, 9.0, 5.5, 4ax-*H*), 1.82 (1 H, m, 7-*H*), 1.64 (1 H, dddd, *J* 14.0, 6.5, 6.0, 3.5, 4eq-*H*), 1.04 (3 H, d, *J* 6.5, $\text{CH}(\text{CH}_3)_2$), 0.91 (3 H, d, *J* 7.0, 9-*H*₃), 0.86 (3 H, d, *J* 6.5, $\text{CH}(\text{CH}_3)_2$); δ_{C} (126 MHz; CDCl_3) 172.16 (C=O), 88.27 (6-*C*), 29.71 (7-*C*), 26.76 (5-*C*), 26.53 (4-*C*), 26.06 (3-*C*), 19.66 ($\text{CH}(\text{CH}_3)_2$), 17.95

(CH(CH₃)₂), 11.38 (9-C); *m/z* (EI) 156 (M⁺, 14 %), 128 (31 %), 113 (M⁺-ⁱPr, 100 %), 85 (84 %), 84 (88 %); all data from which agrees with that given in the literature.

1-Phenyl-1-trimethylsilyl-2-(prop-2'-yl)-4,5-dimethylsilacyclohex-4-ene **239**

1-Phenyl-1-isobutyl-2,2,2-trimethyl-1-(3-methyl-2-methylene-but-3-enyl)-disilane **277**

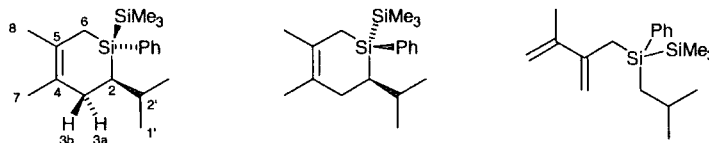

• Method 1¹⁰

Methylolithium (1.6 M solution in ether, 12.8 ml, 20.5 mmol) was added to a stirred solution of silyl alcohol **182** (6.65 g, 20.5 mmol) and 2,3-dimethylbutadiene (13.9 ml, 123.1 mmol) in ether (290 ml) at -78 °C. The mixture was allowed to warm to -30 °C and stirred for 16 h, then to 0 °C for 5 h. Saturated ammonium chloride solution (200 ml) was added and the mixture allowed to reach RT. The aqueous layer was separated and extracted with ether (3 x 150 ml). The combined organic layers were dried over MgSO₄, filtered, concentrated and dried *in vacuo*. Flash column chromatography (pet. ether) gave the title compounds as a colourless oil (2.93 g, 45 %) as a mixture in a ratio of 83 : 8 : 7 % (ratio of product peak integrals by GC), composed of 2 diastereoisomers of the title silacycle **239** and 1-Phenyl-1-isobutyl-2,2,2-trimethyl-1-(3-methyl-2-methylene-but-3-enyl)-disilane **277**.

• Method 2

n-Butyllithium (1.6 M solution in hexane, 0.22 ml, 0.35 mmol) was added to a stirred solution of silyl alcohol **182** (0.11 g, 0.35 mmol) and 2,3-dimethylbutadiene (0.23 ml, 2.07 mmol) in dry ether (5 ml) at RT. The mixture was stirred for 3 h after which time TLC showed complete consumption of starting material. The solution was cooled to -45 °C and an anhydrous suspension of LiBr in ether (0.31 M, 1.11 ml, 0.35 mmol) was added. The mixture was warmed to -30 °C and stirred for 19 h after which time saturated ammonium chloride solution (5 ml) was added and the mixture allowed to reach RT. The aqueous layer was separated and extracted with ether (3 x 5 ml). The combined organic layers were dried over MgSO₄, filtered, concentrated and dried *in vacuo*. Flash column chromatography (pet. ether) gave the title compounds as a colourless oil (0.05 g, 48 %) as a mixture in a ratio of 73 : 15 : 12 % (ratio of product peak integrals by GC); *R_f* (pet. ether) 0.70; *v*_{max} (thin film) 3067, 3049, 2953, 2925, 2866, 1464, 1443, 1430, 1390, 1246, 1121, 1108, 853, 838, 732, 706 cm⁻¹; NMR and MS data of major isomer **239**: δ_H (200 MHz; CDCl₃) 7.48-7.47 (2 H, m, Ar-*H*), 7.30-7.29 (3 H, m, Ar-*H*), 2.23 (1 H, dd, *J* 15.0, 5.0, 3a-*H*), 1.98 (1 H, dd, *J* 15.0, 11.0, 3b-*H*), 1.83 (1 H, m, CH(CH₃)₂), 1.74 (3 H, s, 8-*H*₃), 1.69 (3 H, s, 7-*H*₃), 1.58 (2 H, s,

6-*H*), 1.09 (1 H, ddd, *J* 11.0, 8.5, 5.0, 2-*H*), 0.99 (3 H, d, *J* 7.0, CH(CH₃)₂), 0.98 (3 H, d, *J* 7.0, CH(CH₃)₂), 0.11 (18 H, s, Si(Si(CH₃)₃)₂); δ_C (126 MHz; CDCl₃) 139.51 (*ipso-Ar*), 134.52 (*Ar*), 128.68 (4 or 5-*C*), 128.26 (*Ar*), 127.66 (*Ar*), 125.33 (4 or 5-*C*), 35.33 (3-*C*), 34.47 (2-*C*), 30.30 (2'-*C*), 24.89 (1'-*C*), 22.61 (8-*C*), 22.20 (1'-*C*), 20.74 (7-*C*), 18.92 (6-*C*), -0.33 (Si(Si(CH₃)₃)₂); *m/z* (GCMS, CI) 317 (M+H⁺, 100 %), 316 (M⁺, 65 %), 315 (M⁺-H, 15 %), 303 (25 %), 301 (M⁺-Me, 60 %), 273 (M⁺-^{*i*}Pr, 1 %), 243 (M⁺-SiMe₃, 79 %), 245 (13 %), 239 (M⁺-Ph, 23 %), 187 (24 %), 161 (21 %), 135 (17 %); all data from which agrees with that given by Griffiths; NMR and MS data for 1-phenyl-1-isobutyl-2,2,2-trimethyl-1-(3-methyl-2-methylene-but-3-enyl)-disilane 277: δ_H (200 MHz)(discernable peaks) 5.08 (1 H, s, =CH₂), 5.06 (1 H, s, =CH₂), 4.98 (1 H, s, =CH₂) and 4.86 (1 H, s, =CH₂); *m/z* (GCMS, EI) 316 (M⁺, 13 %), 259 (M⁺-(CH₃)₂CHCH₂, 9 %), 245 (10 %), 243 (M⁺-SiMe₃, 9 %), 235 (M⁺-CH₃CH(CH₂)CH(CH₂)CH₂, 8 %), 187 (72 %), 180 (55 %), 179 (100 %), 177 (22 %), 159 (20 %), 145 (29 %), 135 (84 %), 121 (40 %).

3,4-dimethyl-1-phenyl-6-(prop-2'-yl)-1-trimethylsilyl-silacyclohexane 283-286

1-(2,3-dimethyl-butyl)-1-isobutyl-2,2,2-trimethyl-1-phenyl-disilane 287



A mixture of silanes 239 and 277 (0.57 g, 1.79mmol) and platinum dioxide monohydrate (approx. 0.01 g, 0.04 mmol) in absolute ethanol (8 ml) was repeatedly evacuated and flushed with hydrogen from a balloon.^{175, 177} The mixture was then stirred under the hydrogen atmosphere for 21 h. It was then filtered through a celite pad and washed through with ether (15 ml). The filtrate was concentrated and dried *in vacuo*. Flash column chromatography (pet. ether) gave two separate mixtures:

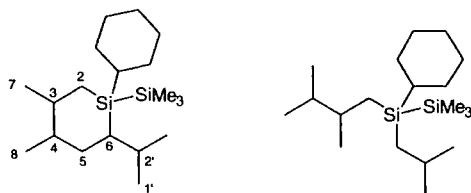

The first fraction (0.03 g, 6 %); R_f (pet. ether) 0.97; consisted of 3 isomers of 1-cyclohexyl-1-trimethylsilyl-3,4-dimethyl-6-(prop-2'-yl)-silacyclohexane; *m/z* (GCMS, EI) 324 (M⁺, 11 %), 251 (M⁺-SiMe₃, 79 %), 241 (M⁺-cyclohexyl, 12 %), 209 (9 %), 195 (24 %), 181 (32 %), 169 (58 %), 127 (45 %); and one of 1-cyclohexyl-1-trimethylsilyl-2-(prop-2'-yl)-4,5-dimethylsilacyclohex-4-ene; *m/z* (GCMS, EI) 322 (M⁺, 9 %), 249 (M⁺-SiMe₃, 50 %), 239

(M^+ -cyclohexyl, 11 %), 193 (48 %), 181 (23 %), 169 (26 %), 167 (27 %); in 15 : 62 : 11: 12 % ratio (ratio of product peak integrals by GC).

The second fraction (0.37 g, 64 %); R_f (pet. ether) 0.87; consisted of the title compounds in the ratio 51 : 30 : 6 : 5 : 8 (ratio of product peak integrals by GC), consisting of four diastereoisomers of the silacycle; m/z (GCMS, EI) 318 (M^+ , 22 %), 245 (M^+ -SiMe₃, 100 %), 203 (34 %), 189 (50 %), 175 (82 %), 161 (44 %), 147 (28 %), 135 (70 %), 121 (28 %), 111 (70 %); and

1-(2,3-dimethyl-butyl)-1-isobutyl-2,2,2-trimethyl-1-phenyl-disilane **287**; m/z (GCMS, EI) 320 (M^+ , 7 %), 247 (M^+ -SiMe₃, 38 %), 235(M^+ -(CH₃)₂CHCH(CH₃)CH₂, 3 %), 221 (4 %), 191 (73 %), 179 (66 %), 163 (39 %), 135 (71 %), 121 (100 %), 107 (82 %), 105 (51 %), 85 ((CH₃)₂CHCH(CH₃)CH₂⁺, 33 %).

(±)-(2R*,3S*,5R*) 2,3,6-Trimethylheptane-1,5-diol **288**

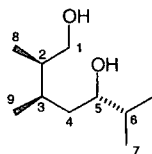

• Stage 1

To a solution of silacycle mixture **283-287** (1.55 g, 4.87 mmol) in dry chloroform (66 ml) was added trifluoroborane-acetic acid complex (13.5 ml, 97.5 mmol).¹⁰ The mixture was then heated to reflux and stirred for 17 h. The solution was then allowed to cool to RT and saturated sodium hydrogen carbonate solution (90 ml) was added. The aqueous layer was separated and extracted with DCM (3 x 90 ml). The combined organic layers were then dried over MgSO₄, filtered, concentrated and dried *in vacuo* to give a dark orange oil which was used immediately in stage 2.

• Stage 2

To the dark orange oil was added potassium hydrogen carbonate (1.88 g, 18.75 mmol) and potassium fluoride (1.12 g, 19.38 mmol). The mixture was dissolved in THF/MeOH solution (1:1, 38 ml) and hydrogen peroxide (35 % w/w solution in water, 11.6 ml, 116.2 mmol) was added. The mixture was heated to reflux and stirred for 21 h.¹⁰ The mixture was then allowed to cool to RT and saturated sodium thiosulfate solution (100 ml) was added together with ether (75 ml). The aqueous layer was separated and extracted with ether (3 x 100 ml). The combined organic extracts were dried over MgSO₄, filtered, concentrated and dried *in vacuo*. Flash column chromatography (pet. ether/ethyl acetate [3:2]) gave the pure title compound as a thick colourless oil (0.33 g, 39 %; R_f (pet. ether/ethyl acetate [1:1])

0.56; ν_{\max} (thin film) 3354 (broad, O-H), 2958, 2931, 2876, 1464, 1383, 1103, 1024, 948, 935 cm^{-1} ; δ_{H} (500 MHz; CDCl_3) 3.57 (1 H, dd, J 7.0, 11.0, 1-*HH*), 3.49 (1 H, dt, J 8.0, 5.0, 5-*H*), 3.46 (1 H, dd, J 10.5, 7.0, 1-*HH*), 1.82 (1 H, m, 3-*H*), 1.71 (1 H, m, 2-*H*), 1.66 (1 H, m, 6-*H*), 1.57 (1 H, ddd, J 14.0, 6.5, 5.0, 4-*HH*), 1.21 (1 H, ddd, J 14.0, 8.0, 7.0, 4-*HH*), 0.94 (3 H, d, J 7.0, 9-*H*₃), 0.92 (3 H, d, J 7.0, $\text{CH}(\text{CH}_3)_2$), 0.88 (3 H, d, J 7.0, $\text{CH}(\text{CH}_3)_2$), 0.87 (3 H, d, J 7.0, 8-*H*₃); δ_{C} (126 MHz; CDCl_3) 75.39 (5-*C*), 65.34 (1-*C*), 39.88 (2-*C*), 37.05 (4-*C*), 32.98 (6-*C*), 30.69 (3-*C*), 19.09 ($\text{CH}(\text{CH}_3)_2$), 18.43 (9-*C*), 16.54 ($\text{CH}(\text{CH}_3)_2$), 13.12 (8-*C*); m/z (ES^+) 197 ($\text{M}+\text{Na}^+$, 100 %); HRMS (ES^+) Found: 175.1697 ($\text{C}_{10}\text{H}_{23}\text{O}_2$ (M^+) requires 175.1698).

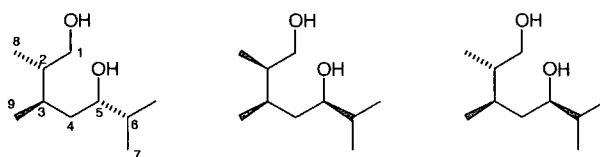

Further elution gave a mixture of diastereoisomers of 2,3,6-trimethylheptane-1,5-diol **289-291** as a white amorphous solid (0.20 g, 24 %); R_f (pet. ether/ethyl acetate [1:1]) 0.29; m.p. 42.0-43.5 °C; ν_{\max} (thin film) 3264 (broad, O-H), 2953, 2909, 2872, 1470, 1381, 1355, 1146, 1025, 989, 857 cm^{-1} ; NMR data for major isomer **289**: δ_{H} (500 MHz; CDCl_3) 3.54-3.39 (3 H, m, 1-*H*₂ and 5-*H*), 1.93 (1 H, m, 3-*H*), 1.79 (1 H, m, 2-*H*), 1.63 (1 H, m, 6-*H*), 1.47 (1 H, ddd, J 14.0, 9.0, 3.5, 4-*HH*), 1.28 (1 H, ddd, J 14.0, 9.0, 5.0, 4-*HH*), 0.92 (3 H, d, J 7.0, $\text{CH}(\text{CH}_3)_2$), 0.90 (3 H, d, J 7.0, $\text{CH}(\text{CH}_3)_2$), 0.82 (3 H, d, J 7.0, 9-*H*₃), 0.76 (3 H, d, J 7.0, 8-*H*₃); δ_{C} (126 MHz; CDCl_3) 73.92 (5-*C*), 66.70 (1-*C*), 38.91 (4-*C*), 37.36 (2-*C*), 33.72 (6-*C*), 29.11 (3-*C*), 18.80 ($\text{CH}(\text{CH}_3)_2$), 17.09 ($\text{CH}(\text{CH}_3)_2$), 15.00 (9-*C*), 10.59 (8-*C*); m/z (ES^+) 197 ($\text{M}+\text{Na}^+$); Elemental Analysis [Found: C, 69.08 %; H, 12.85 %; required for $\text{C}_{10}\text{H}_{23}\text{O}_2$: C, 68.92 %; H, 12.72].

(±)-(2*S**,3*R**,5*S**) 2,3,6-Trimethyl-heptane-1,5-dioxybenzoyl ester **294**

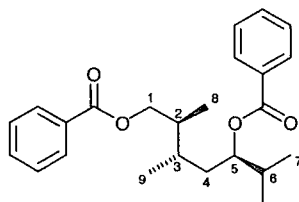

To a solution of diol **288** (0.03 g, 0.16 mmol) and DMAP (0.04 g, 0.30 mmol) in THF (6 ml) was added dropwise a solution of benzoyl chloride (0.19 ml, 1.60 mmol) and triethylamine (0.3 ml, 2.3 mmol) in THF (6 ml). The mixture was stirred at RT for 18 h. Water (10 ml) and ether (10 ml) were then added. The aqueous layer was separated and extracted with ether (3 x 10 ml). The combined organic extracts were dried over MgSO_4 , filtered, concentrated and dried *in vacuo*. Flash column chromatography (hexane/ethyl

acetate [9:1]) gave the pure title compound as a thick colourless oil (0.02 g, 32 %); R_f (hexane/ethyl acetate [4:1]) 0.90; ν_{\max} (thin film) 2964, 2907, 2878, 1714 (C=O), 1602, 1584, 1463, 1451, 1389, 1314, 1273, 1176, 1112, 1070, 1026, 971 cm^{-1} ; δ_H (500 MHz; CDCl_3) 8.05 (4 H, m, Ar-*H*), 7.56 (2 H, t, *J* 7.5, Ar-*H*), 7.44 (4 H, m, Ar-*H*), 5.18 (1 H, m, 5-*H*), 4.29 (1 H, dd, *J* 11.0, 6.0, 1-*HH*), 4.17 (1 H, dd, *J* 11.0, 7.0, 1-*HH*), 2.07 (1 H, m, 2-*H*), 1.97 (1 H, m, 6-*H*), 1.79 (1 H, m, 4-*HH*), 1.73 (1 H, m, 3-*H*), 1.59 (1 H, dt, *J* 13.5, 7.5, 4-*HH*), 1.00 (6 H, d, *J* 7.0, 8-*H*₃ and 9-*H*₃), 0.98 (3 H, d, *J* 7.0, $\text{CH}(\text{CH}_3)_2$), 0.96 (3 H, d, *J* 7.0, $\text{CH}(\text{CH}_3)_2$); δ_C (126 MHz; CDCl_3) 166.64 (C=O), 166.27 (C=O), 132.85 (Ar), 132.76 (Ar), 130.70 (*ipso* Ar), 130.36 (*ipso* Ar), 129.53 (Ar), 129.52 (Ar), 128.33 (Ar (x2)), 77.61 (5-*C*), 67.21 (1-*C*), 36.54 (2-*C*), 34.79 (4-*C*), 32.46 (3-*C*), 31.25 (6-*C*), 18.96 ($\text{CH}(\text{CH}_3)_2$), 16.90 (8 or 9-*C*), 16.72 ($\text{CH}(\text{CH}_3)_2$), 14.53 (8 or 9-*C*); m/z (CI) 400 ($\text{M}+\text{NH}_4^+$, 100 %), 383 ($\text{M}+\text{H}^+$, 4 %), 338 (8 %), 324 (4 %), 278 ($\text{M}-\text{PhCO}+\text{H}^+$, 38 %), 261 (M^+-PhCO_2 , 70 %), 218 (10 %), 200 (13 %), 183 (54 %), 156 (10 %); HRMS (CI) Found: 400.2483 ($\text{C}_{24}\text{H}_{33}\text{NO}_4$ ($\text{M}+\text{NH}_4^+$) requires 400.2488).

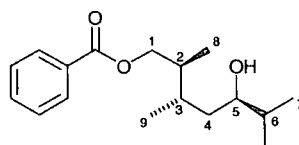

Further elution followed by washing with saturated aqueous sodium hydrogen carbonate solution to remove excess acid gave benzoic acid 5-hydroxy-2,3,6-trimethyl heptyl ester as a clear oil (0.01 g, 19 %); R_f (hexane/ethyl acetate [9:1]) 0.58; ν_{\max} (thin film) 3423 (broad, O-H), 2960, 2929, 2875, 1720 (C=O), 1601, 1451, 1383, 1275, 1213, 1175, 1113, 1070, 1026, 987 cm^{-1} ; δ_H (500 MHz; CDCl_3) 8.04 (2 H, d, *J* 8.5, Ar-*H*), 7.55 (1 H, m, Ar-*H*), 7.44 (2 H, t, *J* 7.5, Ar-*H*), 4.31 (1 H, dd, *J* 11.0, 6.5, 1-*HH*), 4.14 (1 H, dd, *J* 11.0, 7.5, 1-*HH*), 3.54 (1 H, dt, *J* 8.0, 4.5, 5-*H*), 2.04 (1 H, m, 2-*H*), 1.81 (1 H, m, 3-*H*), 1.69-1.60 (2 H, m's, 4-*HH* and 6-*H*), 1.29 (1 H, ddd, *J* 14.5, 8.0, 7.5, 4-*HH*), 1.03 (3 H, d, *J* 7.0, 8-*H*₃), 1.01 (3 H, d, *J* 7.0, 9-*H*₃), 0.93 (3 H, d, *J* 7.0, $\text{CH}(\text{CH}_3)_2$), 0.87 (3 H, d, *J* 7.0, $\text{CH}(\text{CH}_3)_2$); δ_C (126 MHz; CDCl_3) 166.69 (C=O), 132.86 (Ar), 130.57 (*ipso*-Ar), 129.51 (Ar), 128.35 (Ar), 75.04 (5-*C*), 67.38 (1-*C*), 37.95 (4-*C*), 36.31 (2-*C*), 33.13 (6-*C*), 32.66 (3-*C*), 19.09 ($\text{CH}(\text{CH}_3)_2$), 17.31 (9-*C*), 16.08 ($\text{CH}(\text{CH}_3)_2$), 14.62 (8-*C*); m/z (ES⁺) 579 (M_2Na^+ , 3 %), 301 ($\text{M}+\text{Na}^+$, 100 %); HRMS (CI) Found: 301.1779 ($\text{C}_{17}\text{H}_{26}\text{O}_3\text{Na}$ requires ($\text{M}+\text{Na}^+$) 301.1780).

2,3,6-Trimethyl-heptane-1,5-dioxybenzoyl ester 295-297

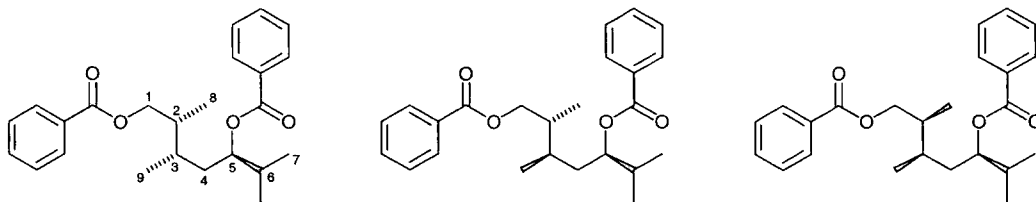

To a solution of diol mixture **289-291** (0.03 g, 0.18 mmol) and DMAP (0.04 g, 0.34 mmol) in THF (7 ml) was added dropwise a solution of benzoyl chloride (0.21 ml, 1.84 mmol) and triethylamine (0.37 ml, 2.68 mmol) in THF (7 ml). The mixture was stirred at RT for 19 h. Saturated sodium hydrogen carbonate solution (10 ml) and ether (10 ml) were then added. The aqueous layer was separated and extracted with ether (3 x 10 ml). The combined organic extracts were dried over MgSO_4 , filtered, concentrated and dried *in vacuo*. Flash column chromatography (pet. ether/ethyl acetate [9:1]) gave the title compounds as a thick clear oil (0.04 g, 60 %) as a mixture in a ratio of 82 : 12 : 6 (ratio of product peak integrals by GC); R_f (hexane/ethyl acetate [4:1]) 0.85; data for the major diastereoisomer **295**: ν_{max} (thin film) 2963, 2877, 1717 (C=O), 1601, 1584, 1491, 1465, 1451, 1388, 1370, 1314, 1275, 1176, 1112, 1069, 1026, 971, 711 cm^{-1} ; δ_{H} (500 MHz; CDCl_3) 8.04 (2 H, dd, J 7.5, 1.0, Ar-H), 7.93 (2 H, dd, J 7.5, 1.0, Ar-H), 7.55 (1 H, tt, J 7.5, 1.0, Ar-H), 7.49 (1 H, tt, J 7.5, 1.0, Ar-H), 7.42 (2 H, t, J 7.5, Ar-H), 7.30 (2 H, t, J 7.5, Ar-H), 5.17 (1 H, dt, J 9.0, 4.5, 5-H), 4.18 (1 H, d, J 7.5, 1-HH), 4.17 (1 H, d, J 6.5, 1-HH), 2.22 (1 H, m, 2-H), 1.97 (1 H, m, 6-H), 1.88 (1 H, m, 3-H), 1.74-1.61 (2 H, m, 4- H_2), 0.99 (3 H, d, J 5.0, $\text{CH}(\text{CH}_3)_2$), 0.98 (3 H, d, J 5.0, $\text{CH}(\text{CH}_3)_2$), 0.91 (3 H, d, J 7.0, 8- H_3), 0.90 (3 H, d, J 7.0, 9- H_3); δ_{C} (126 MHz; CDCl_3) 166.56 (C=O), 166.21 (C=O), 132.70 (Ar), 132.63 (Ar), 130.58 (*ipso* Ar), 130.28 (*ipso* Ar), 129.53 (Ar), 129.44 (Ar), 128.30 (Ar), 128.19 (Ar), 76.74 (5-C), 67.99 (1-C), 35.72 (4-C), 34.55 (2-C), 31.78 (6-C), 29.80 (3-C), 18.59 ($\text{CH}(\text{CH}_3)_2$), 17.33 ($\text{CH}(\text{CH}_3)_2$), 14.86 (9-C), 10.79 (8-C); m/z (GCMS, CI) 401 ($\text{M}+\text{NH}_4+\text{H}^+$, 60 %), 400 ($\text{M}+\text{NH}_4^+$, 100 %), 383 ($\text{M}+\text{H}^+$, 44 %), 278 (M^+-PhCO , 51 %), 261 (M^+-PhCO_2 , 90 %), 156 (13 %), 139 (36 %), 122 (30 %), 105 (61 %), 95 (32 %).

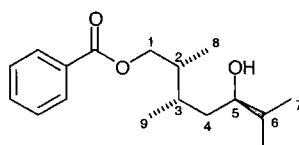

Further elution gave Benzoic acid 5-hydroxy-2,3,6-trimethyl heptyl ester as a clear oil (0.01 g, 26 %); R_f (hexane/ethyl acetate [4:1]) 0.56; ν_{max} (thin film) 3493 (broad, O-H), 2960, 2927, 2876, 1721 (C=O), 1602, 1468, 1452, 1383, 1276, 1177, 1115, 1070, 1027, 985 cm^{-1} ; δ_{H} (500 MHz; CDCl_3) 8.04 (2 H, d, J 8.0, Ar-H), 7.55 (1 H, m, Ar-H), 7.44 (2 H, t, J 8.0, Ar-H), 4.25 (1 H, dd, J 11.0, 4.0, 1-HH), 4.19 (1 H, dd, J 11.0, 7.0, 1-HH), 3.49 (1 H, dt, J

9.0, 4.5, 5-*H*), 2.11 (1 H, m, 2-*H*), 1.97 (1 H, m, 3-*H*), 1.65 (1 H, m, 4-*HH*), 1.53 (1 H, m, 6-*H*), 1.32 (1 H, m, 4-*HH*), 0.94 (3 H, d, *J* 7.0, CH(CH₃)₂), 0.91 (3 H, d, *J* 7.0, 8-*H*₃), 0.91 (3 H, d, *J* 7.0, 9-*H*₃), 0.90 (3 H, d, *J* 7.0, CH(CH₃)₂); δ_C (126 MHz; CDCl₃) 166.66 (C=O), 132.84 (*Ar*), 130.42 (*ipso Ar*), 129.51 (*Ar*), 128.34 (*Ar*), 74.30 (5-*C*), 68.63 (1-*C*), 38.89 (4-*C*), 34.75 (2-*C*), 33.63 (6-*C*), 30.30 (3-*C*), 18.85 (CH(CH₃)₂), 16.71 (CH(CH₃)₂), 15.25 (8-*C*), 10.97 (9-*C*); *m/z* (ES⁺) 579 (M₂Na⁺, 3 %), 301 (M+Na⁺, 100 %); HRMS (ES⁺) Found: 279.1963 (C₁₇H₂₇O₃ (M⁺) requires 279.1960).

(±)-(6*S**, 3*S**, 4*R**)-Isopropyl-3,4-dimethyl-tetrahydro-pyran-2-one **298**

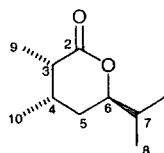

To a solution of diol **288** (0.07 g, 0.43 mmol) in dry DCM (6 ml) was added powdered molecular sieves (4 Å, approx. 0.3 g), NMO (0.20 g, 1.67 mmol) and TPAP (0.01 g, 0.02 mmol).¹⁶⁸⁻¹⁷⁰ The mixture was stirred at RT for 23 h. It was then diluted with ether (12 ml), filtered through silica and washed through with more ether. The filtrate was concentrated under reduced pressure. [High vacuum was not used as the product is volatile]. Flash column chromatography (pet. ether/ether [3:2]) gave the pure title compound as a clear oil (0.05 g, 63 %); *R_f* (hexane/ether [1:1]) 0.73; ν_{\max} (thin film) 2963, 2933, 2870, 1731 (C=O), 1457, 1387, 1181, 1133, 1088, 1032, 987 cm⁻¹; δ_H (500 MHz; CDCl₃) 4.22 (1 H, dt, *J* 11.0, 5.0, 6-*H*), 2.49 (1 H, qd, *J* 7.0, 5.0, 3-*H*), 2.12 (1 H, m, 4-*H*), 1.86-1.75 (2 H, m, 5eq-*H* and CH(CH₃)₂), 1.70 (1 H, dt, *J* 14.0, 5.0, 5ax-*H*), 1.16 (3 H, d, *J* 7.0, 9-*H*₃), 0.97 (3 H, d, *J* 7.5, 10-*H*₃), 0.93 (3 H, d, *J* 7.0, CH(CH₃)₂), 0.90 (3 H, d, *J* 7.0, CH(CH₃)₂); δ_C (100 MHz; CDCl₃) 174.67 (C=O), 81.61 (6-*C*), 40.58 (3-*C*), 33.04 (7-*C*), 32.66 (5-*C*), 30.15 (4-*C*), 17.61 (CH(CH₃)₂), 17.52 (CH(CH₃)₂), 14.04 (10-*C*), 13.67 (9-*C*); *m/z* (EI) 170 (M⁺, 32 %), 128 (26 %), 127 (M⁺-i-Pr, 56 %), 100 (27 %), 99 (63 %), 56 (100 %); HRMS (EI) Found: 170.1305 (C₁₀H₁₈O₂ (M⁺) requires 170.1307).

6-Isopropyl-3,4-dimethyl-tetrahydro-pyran-2-one **299-301**

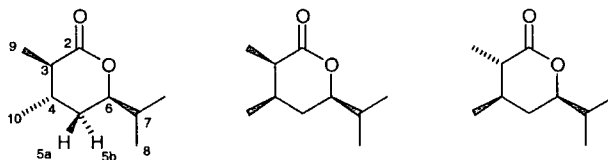

To a solution of diol mixture **289-291** (0.04 g, 0.25 mmol) in dry DCM (4 ml) was added powdered molecular sieves (4 Å, approx. 0.15 g), NMO (0.11 g, 0.97 mmol) and TPAP (0.01 g, 0.01 mmol).¹⁶⁸⁻¹⁷⁰ The mixture was stirred at RT for 19 h. It was then diluted with

ether (10 ml), filtered through silica and washed through with more ether. The filtrate was concentrated under reduced pressure. [High vacuum was not used as the product is volatile]. Flash column chromatography (pet. ether/ether [3:2]) gave the title compounds as a clear oil (0.03 g, 64 %) as a mixture of diastereoisomers in a ratio of 84 : 12 : 4 (ratio of product peak integrals by GC); R_f (hexane/ether [1:1]) 0.57; ν_{\max} (thin film) 2965, 2934, 2877, 1742 (C=O), 1456, 1373, 1358, 1259, 1237, 1199, 1138, 1097, 1049, 999 cm^{-1} ; NMR data for the major isomer **299**: δ_H (500 MHz; CDCl_3) 4.00 (1 H, ddd, J 11.0, 6.0, 3.0, 6-*H*), 2.15 (1 H, m, 3-*H*), 1.86 (1 H, m, 5a-*H*), 1.81 (1 H, m, $\text{CH}(\text{CH}_3)_2$), 1.70 (1 H, m, 4-*H*), 1.48 (1 H, dt, J 14.0, 3.5, 5b-*H*), 1.21 (3 H, d, J 7.0, 9- H_3), 1.11 (3 H, d, J 6.5, 10- H_3), 0.98 (3 H, d, J 7.0, $\text{CH}(\text{CH}_3)_2$), 0.93 (3 H, d, J 7.0, $\text{CH}(\text{CH}_3)_2$); δ_C (126 MHz; CDCl_3) 176.44 (C=O), 80.18 (6-*C*), 40.46 (3-*C*), 32.81 (5-*C*), 32.11 ($\text{CH}(\text{CH}_3)_2$), 31.03 (4-*C*), 21.19 (10-*C*), 18.01 ($\text{CH}(\text{CH}_3)_2$), 17.85 ($\text{CH}(\text{CH}_3)_2$), 14.20 (9-*C*); m/z (EI) 170 (M^+ , 8 %), 128 (20 %), 127 (M^+ - ^iPr , 100 %), 99 (83 %), 83 (33 %), 81 (73 %), 71 (34 %), 70 (52 %), 69 (50 %).

1-Phenyl-1-trimethylsilyl-2-(prop-2'-yl)-5-methylsilacyclohex-4-ene 302

1-Phenyl-1-trimethylsilyl-2-(prop-2'-yl)-4-methylsilacyclohex-4-ene 303

1-Phenyl-1-isobutyl-2,2,2-trimethyl-1-(2-methylene-but-3-enyl)-disilane 304

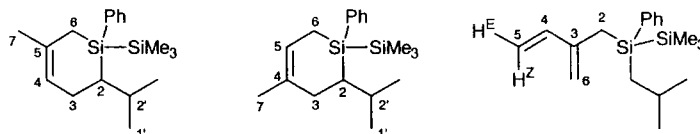

• **Method 1**¹⁰

Methylolithium (1.6 M solution in ether, 0.60 ml, 1.04 mmol) was added to a stirred solution of silyl alcohol **182** (0.34 g, 1.04 mmol) and isoprene (0.63 ml, 6.26 mmol) in ether (10 ml) at -78°C . The mixture was allowed to warm to -30°C and stirred for 18 h. Saturated ammonium chloride solution (15 ml) was added and the mixture allowed to reach RT. The aqueous layer was separated and extracted with ether (3 x 15 ml). The combined organic layers were dried over MgSO_4 , filtered, concentrated and dried *in vacuo*. Flash column chromatography (pet. ether) gave the title compounds as a colourless oil (0.08 g, 27 %); R_f (pet. ether) 0.73; as a mixture in a ratio of 84 : 11 : 5 % (ratio of product peak integrals by GC).

• **Method 2**

n-Butyllithium (1.6 M solution in hexane, 1.18 ml, 1.90 mmol) was added to a stirred solution of silyl alcohol **182** (0.61 g, 1.88 mmol) and freshly distilled isoprene (1.13 ml, 11.26 mmol) in dry ether (27 ml) at RT. The mixture was stirred for 3 h after which time TLC showed complete consumption of starting material. The solution was cooled to -45°C

and an anhydrous suspension of LiBr in ether (0.31 M, 6.04 ml, 1.88 mmol) was added. The mixture was warmed to $-30\text{ }^{\circ}\text{C}$ and stirred for 41 h after which time saturated ammonium chloride solution (30 ml) was added and the mixture allowed to reach RT. The aqueous layer was separated and extracted with ether (3 x 30 ml). The combined organic layers were dried over MgSO_4 , filtered, concentrated and dried *in vacuo*. Flash column chromatography (pet. ether) gave the title compounds as a colourless oil (0.23 g, 41 %) as a mixture in a ratio of 72 : 16 : 12 % (ratio of product peak integrals by GC), ν_{max} (thin film) 2954, 2927, 2893, 2869, 1462, 1445, 1427, 1244, 1101, 855, 833, 733, 719, 699 cm^{-1} ; data for major isomer, 1-phenyl-1-trimethylsilyl-2-(prop-2'-yl)-5-methylsilacyclohex-4-ene **302**: δ_{H} (500 MHz; CDCl_3) 7.51-7.49 (2 H, m, *meta* Ar-H), 7.32-7.31 (3 H, m, *ortho* and *para* Ar-H), 5.48 (1 H, m, 4-H), 2.34 (1 H, dt, J 15.5, 6.5, 3-HH), 1.96 (1 H, m, 3-HH), 1.87 (1 H, m, $\text{CH}(\text{CH}_3)_2$), 1.78 (3 H, s, 7- H_3), 1.53 (2 H, m, 6- H_2), 1.14 (1 H, m, 2-H), 0.96 (3 H, d, J 6.5, $\text{CH}(\text{CH}_3)_2$), 0.94 (3 H, d, J 6.5, $\text{CH}(\text{CH}_3)_2$), 0.18 (9 H, s, $\text{Si}(\text{CH}_3)_3$); δ_{C} (126 MHz; CDCl_3) 134.45 (*meta*-Ar), 128.34 (*para*-Ar), 127.71 (*ortho*-Ar), 123.80 (4-C), 32.34 (2-C), 30.27 (2'-C), 27.75 (3-C), 27.62 (7-C), 24.51 (1'-C), 21.90 (1'-C), 16.38 (6-C), -0.37 ($\text{Si}(\text{CH}_3)_3$); m/z (GCMS, CI) 303 ($\text{M}+\text{H}^+$, 39 %), 302 (M^+ , 96 %), 288 ($\text{M}+\text{H}^+$ -Me, 31 %), 287 (M^+ -Me, 100 %), 245 (16 %), 233 (10 %), 231 (18 %), 230 ($\text{M}+\text{H}^+$ - SiMe_3 , 29 %), 229 (M^+ - SiMe_3 , 86 %), 225 (35 %), 217 (13 %), 193 (14 %), 179 (14 %), 173 (23 %), 169 (13 %), 167 (11 %), 161 (48 %), 155 (24 %), 152 (16 %), 135 (49 %); HRMS (EI) Found: 302.1882 ($\text{C}_{18}\text{H}_{30}\text{Si}_2$ (M^+) requires 302.1886); data for 1-phenyl-1-trimethylsilyl-2-(prop-2'-yl)-4-methylsilacyclohex-4-ene **303**: δ_{H} (500 MHz; CDCl_3) (Discernable peak) 5.61 (1 H, m, 5-H); m/z (GCMS, CI) 303 ($\text{M}+\text{H}^+$, 24 %), 302 (M^+ , 93 %), 288 ($\text{M}+\text{H}^+$ -Me, 31 %), 287 (M^+ -Me, 100 %), 245 (17 %), 233 (11 %), 231 (20 %), 230 ($\text{M}+\text{H}^+$ - SiMe_3 , 33 %), 229 (M^+ - SiMe_3 , 94 %), 225 (29 %), 217 (13 %), 193 (21 %), 179 (31 %), 173 (31 %), 169 (13 %), 167 (14 %), 161 (62 %), 155 (24 %), 152 (20 %), 145 (10 %), 135 (49 %); data for 1-phenyl-1-isobutyl-2,2,2-trimethyl-1-(2-methylene-but-3-enyl)-disilane **304**: δ_{H} (500 MHz; CDCl_3) (Discernable peaks) 6.35 (1 H, dd, J 16.5, 10.5, 4-H), 5.11 (1 H, d, J 16.5, 5- H^Z), 5.01 (1 H, d, J 10.5, 5- H^E), 4.94 (1 H, s, 6-HH), 4.81 (1 H, s, 6-HH); m/z (GCMS, CI) 302 (M^+ , 13 %), 287 (M^+ -Me, 10 %), 247 (14 %), 246 (24 %), 245 (M^+ - CH_2^iPr , 50 %), 235 (M^+ - $\text{CH}_2\text{C}(\text{=CH}_2)\text{CH}=\text{CH}_2$, 23 %), 231 (31 %), 179 (100 %), 173 (13 %), 169 (15 %), 135 (26 %), 105 (12 %).

1-*p*-Methoxyphenyl-1-trimethylsilyl-2-(prop-2'-yl)-5-methylsilacyclohex-4-ene 306

1-*p*-Methoxyphenyl-1-trimethylsilyl-2-(prop-2'-yl)-4-methylsilacyclohex-4-ene 307

1-*p*-Methoxyphenyl-1-isobutyl-2,2,2-trimethyl-1-(2-methylene-but-3-enyl)-disilane 308

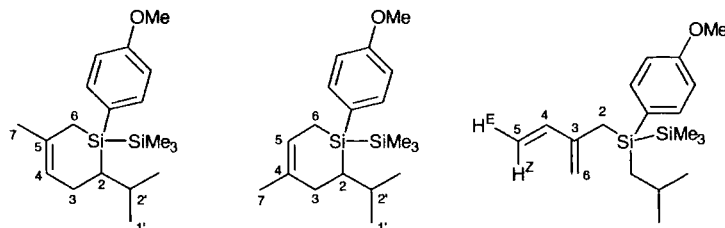

n-Butyllithium (1.6 M solution in hexane, 2.09 ml, 3.34 mmol) was added to a stirred solution of silyl alcohol **237** (1.17 g, 3.31 mmol) and isoprene (1.98 ml, 19.83 mmol) in dry ether (45 ml) at RT. The mixture was stirred for 3 h then cooled to $-45\text{ }^{\circ}\text{C}$. An anhydrous solution of LiBr in ether (0.31 M, 0.53 ml, 0.17 mmol) was added and the mixture was warmed to $-30\text{ }^{\circ}\text{C}$ and stirred for 18 h. Saturated ammonium chloride solution (45 ml) was added and the mixture allowed to reach RT. The aqueous layer was separated and extracted with ether (3 x 45 ml). The combined organic layers were dried over MgSO_4 , filtered, concentrated and dried *in vacuo*. Flash column chromatography, gradient elution (pet. ether, pet. ether/ether [49:1]) gave the title compounds as a colourless oil (0.15 g, 14 %); R_f (pet. ether/ether [19:1]) 0.75; as a mixture in a ratio of 74 : 12 : 14 % (ratio of product peak integrals by GC), ν_{max} (thin film) 2954, 2894, 2869, 2835, 1593, 1564, 1501, 1462, 1441, 1276, 1245, 1181, 1101, 1035, 856, 833 cm^{-1} ; data for 1-*p*-methoxyphenyl-1-trimethylsilyl-2-(prop-2'-yl)-5-methylsilacyclohex-4-ene **306**: δ_{H} (500 MHz; CDCl_3) 7.42 (2 H, d, J 9.0, *ortho*-Ar-*H*), 6.89 (2 H, d, J 9.0, *meta*-Ar-*H*), 5.47 (1 H, m, 4-*H*), 2.33 (1 H, dt, J 16.0, 5.5, 3-*HH*), 1.95 (1 H, m, 3-*HH*), 1.84 (1 H, m, $\text{CH}(\text{CH}_3)_2$), 1.78 (3 H, s, 7-*H*₃), 1.53 (1 H, d, 6-*HH*), 1.47 (1 H, d, 6-*HH*), 1.09 (1 H, ddd, J 11.0, 7.5, 5.5, 2-*H*), 0.95 (3 H, d, J 6.5, $\text{CH}(\text{CH}_3)_2$), 0.93 (3 H, d, J 6.5, $\text{CH}(\text{CH}_3)_2$), 0.18 (9 H, s, $\text{Si}(\text{CH}_3)_3$); δ_{C} (126 MHz; CDCl_3) 159.90 (MeO-*C*), 135.79 (*ortho*-Ar), 123.77 (4-*C*), 113.54 (*meta*-Ar), 54.92 (OCH₃), 32.54 (2-*C*), 30.25 (2'-*C*), 27.82 (3-*C*), 27.65 (7-*C*), 24.47 (1'-*C*), 21.19 (1'-*C*), 16.69 (6-*C*), -0.33 ($\text{Si}(\text{CH}_3)_3$); m/z (GCMS, EI) 332 (M^+ , 25 %), 317 (M^+ -Me, 13 %), 277 (37 %), 259 (M^+ - SiMe_3 , 79 %), 249 (34 %), 247 (22 %), 224 (30 %), 215 (15 %), 209 (48 %), 203 (78 %), 191 (100 %), 165 (72 %), 151 (73 %), 135 (74 %); data for 1-*p*-methoxyphenyl-1-trimethylsilyl-2-(prop-2'-yl)-4-methylsilacyclohex-4-ene **307**: δ_{H} (Discernable peak)(500 MHz; CDCl_3) 5.60 (1 h, m, 5-*H*); m/z (GCMS, EI) 332 (M^+ , 12 %), 317 (M^+ -Me, 3 %), 277 (16 %), 259 (M^+ - SiMe_3 , 71 %), 249 (14 %), 224 (14 %), 215 (15 %), 209 (21 %), 203 (75 %), 191 (100 %), 165 (60 %), 151 (65 %), 135 (60 %); data for 1-*p*-methoxyphenyl-1-isobutyl-2,2,2-trimethyl-1-(2-methylene-but-3-enyl)-disilane **308**: δ_{H} (Discernable peaks)(500 MHz; CDCl_3) 6.34 (1 H, dd, J 17.5, 10.5, 4-*H*), 5.12 (1 H, d, J 17.5, 4- H^Z), 5.00

(1 H, d, J 10.5, 4- H^E), 4.93 (1 H, s, 6- HH), 4.80 (1 H, s, 6- HH); m/z (GCMS, EI) 332 (M^+ , 4 %), 317 (M^+ -Me, 2 %), 275 (M^+ - t Bu, 25 %), 265 (M^+ - $CH_2CH(CH_2)CHCH_2$, 10 %), 261 (14 %), 224 (8%), 209 (100 %), 203 (55 %), 179 (60 %), 165 (84 %), 151 (42 %), 135 (75 %).

3-Methyl-1-phenyl-6-(prop-2'-yl)-1-trimethylsilyl-silacyclohexane 309-310

4-Methyl-1-phenyl-6-(prop-2'-yl)-1-trimethylsilyl-silacyclohexane 311

1-Phenyl-1-isobutyl-2,2,2-trimethyl-1-(2-methyl-butyl)-disilane 312

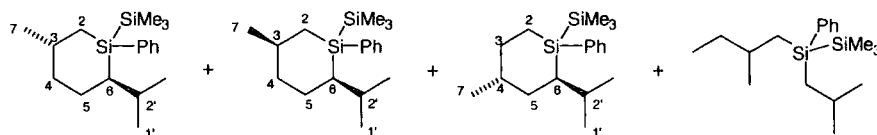

A mixture of silanes **302-304** (0.50 g, 1.66 mmol) and platinum dioxide hydrate (18 mg, 0.073 mmol) in ethyl acetate (15 ml) was repeatedly evacuated and flushed with hydrogen from a balloon.^{175, 177} The mixture was then stirred under the hydrogen atmosphere for 17 h. TLC at this time showed incomplete consumption of starting material and formation of product, so further platinum dioxide hydrate (28 mg, 0.114 mmol) was added and flushed with hydrogen. This was repeated after 48 h and stirred for a further 21 h after which time TLC showed complete conversion. The reaction mixture was filtered through celite and washed through with ether. The filtrate was concentrated and dried *in vacuo*. Flash column chromatography (pet. ether) gave the title compounds as a clear oil (0.29 g, 58 %); R_f (pet. ether) 0.79 as a mixture in a ratio of 62 : 16 : 8 : 4 : 10 % (ratio of product peak integrals by GC), which consisted of 4 silacyclohexane isomers **309-311**; m/z (GCMS, EI) 304 (M^+ , 32 %), 231 (M^+ -SiMe₃, 98 %), 189 (48 %), 175 (60 %), 161 (100 %), 135 (79 %), 121 (94 %), 107 (64 %), 105 (PhSi⁺, 73 %) and 1-(2-methyl-butyl)-1-isobutyl-2,2,2-trimethyl-1-phenyl-disilane **312**; m/z (GCMS, EI) 306 (M^+ , 14 %), 233 (M^+ -SiMe₃, 50 %), 179 (61 %), 177 (88 %), 163 (50 %), 135 (68 %), 121 (100 %), 107 (100 %), 105 (PhSi⁺, 47 %), 99 (Si-CH₂CH(CH₃)CH₂CH₃⁺, 38 %), 85 (Si-CH₂CH(CH₃)₂⁺, 20 %).

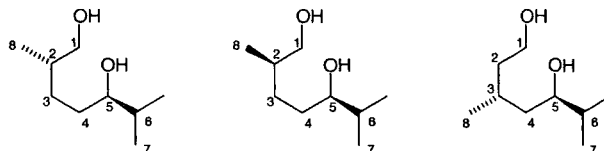
(±)-(2S*,5S*) 2,6-dimethylheptane-1,5-diol 313**(±)-(2R*,5S*) 2,6-dimethylheptane-1,5-diol 314****(±)-(3S*,5S*) 3,6-dimethylheptane-1,5-diol 315**

- **Stage 1**

To a solution of silane mixture **309-312** (0.30 g, 0.97 mmol) in dry chloroform (13 ml) was added trifluoroborane-acetic acid complex (2.70 ml, 19.47 mmol).¹⁰ The mixture was then heated to reflux and stirred for 19 h. The solution was then allowed to cool to RT and saturated sodium hydrogen carbonate solution (15 ml) was added. The aqueous layer was separated and extracted with DCM (3 x 15 ml). The combined organic layers were then dried over MgSO₄, filtered, concentrated and dried *in vacuo* to give an orange oil which was used immediately in stage 2.

- **Stage 2**

To the orange oil was added potassium hydrogen carbonate (0.38 g, 3.75 mmol) and potassium fluoride (0.23 g, 3.88 mmol). The mixture was dissolved in THF/MeOH solution (1:1, 8 ml) and hydrogen peroxide (35 % w/w solution in water, 2.3 ml, 23.2 mmol) was added. The mixture was heated to reflux and stirred for 17 h.¹⁰ The mixture was then allowed to cool to RT and saturated sodium thiosulfate solution (20 ml) and ethyl acetate (20 ml) was added. The aqueous layer was separated and extracted with ethyl acetate (3 x 20 ml). The combined organic extracts were dried over MgSO₄, filtered, concentrated and dried *in vacuo*. Flash column chromatography (pet. ether/ethyl acetate [1:1]) gave the title compounds as an inseparable mixture as a thick colourless oil (0.03 g, 19 %); R_f (pet. ether/ethyl acetate [1:1]) 0.20; ν_{max} (thin film) 3355 (broad, O-H), 2956, 2930, 2873, 1463, 1384, 1367, 1108, 1042, 993 cm⁻¹; NMR data for the major isomer **313**: δ_H (500 MHz; CDCl₃)(discernable peaks) 3.45 (2 H, m, 1-H₂), 3.32 (1 H, ddd, J 8.5, 5.0, 3.5, 5-H), 0.90 (3 H, d, J 6.5, 7-H₃ or 8-H₃), 0.90 (3 H, d, J 6.0 7-H₃ or 8-H₃), 0.89 (3 H, d, J 7.0, 7-H₃ or 8-H₃); δ_C (126 MHz; CDCl₃) 77.13 (5-C), 67.59 (1-C), 35.83, 33.49, 31.28, 29.43, 18.82 (7-C or 8-C), 17.10 (7-C or 8-C), 16.89 (7-C or 8-C); m/z (ES⁺) 183 (M+Na⁺, 100 %); HRMS (ES⁺) Found: 183.1364 (C₉H₂₀O₂Na (M+Na⁺) requires 183.1361).

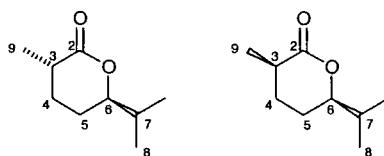
(±)-(6S*,3R*) 6-Isopropyl-3-methyl-tetrahydro-pyran-2-one 316**(±)-(6S*,3S*) 6-Isopropyl-3-methyl-tetrahydro-pyran-2-one 317**

To a solution of diol mixture **313-315** (35 mg, 0.22 mmol) in dry DCM (4 ml) was added powdered molecular sieves (4 Å, approx. 0.3 g), NMO (101 mg, 0.86 mmol) and TPAP (2.8 mg, 0.0081 mmol).¹⁶⁸⁻¹⁷⁰ The mixture was stirred at RT for 25 h. It was then diluted with ether, filtered through silica and washed through with more ether. The filtrate was concentrated under reduced pressure. [High vacuum was not used as the products are volatile]. Flash column chromatography, gradient elution (pet. ether/ether [5:1], [2:1]) gave the title compounds as a clear oil (12 mg, 35 %) as a mixture in 66 : 34 % ratio (by GC and NMR); R_f (pet. ether/ether [1:1]) 0.45; ν_{\max} (thin film) 2965, 2936, 2877, 1737 and 1731 (C=O), 1462, 1377, 1243, 1186, 1119, 1093, 1012, 996, 931 cm^{-1} ; δ_H (500 MHz; CDCl_3) 4.08 (1 H, ddd, J 11.0, 5.5, 3.0, 6-*H*), 4.01 (0.6 H, ddd, J 11.5, 6.5, 3.5, 6-*H**), 2.59 (0.6 H, m, 3-*H**), 2.40 (1 H, m, 3-*H*), 2.07 (0.6 H, m, 4-*HH**), 2.02 (1 H, m, 4-*HH*), 1.91-1.81 (3.2 H, m, 5-*H*, $\text{CH}(\text{CH}_3)_2$, 5-*HH** and $\text{CH}(\text{CH}_3)_2^*$), 1.68-1.46 (3.2 H, m, 5-*HH*, 4-*HH*, 5-*HH** and 4-*HH**), 1.29 (3 H, d, J 7.0, 9-*H*₃), 1.20 (1.8 H, d, J 6.5, 9-*H*₃*), 0.99 (1.8 H, d, J 7.0, $\text{CH}(\text{CH}_3)_2^*$), 0.97 (3 H, d, J 7.0, $\text{CH}(\text{CH}_3)_2$), 0.95 (3 H, d, J 7.0, $\text{CH}(\text{CH}_3)_2$), 0.94 (3 H, d, J 7.0, $\text{CH}(\text{CH}_3)_2^*$); δ_C (100 MHz; CDCl_3) 176.65 (C=O*), 174.66 (C=O), 86.41 (6-*C*), 82.70 (6-*C**), 36.21 (3-*C*), 32.98 (3-*C**), 32.92 ($\text{CH}(\text{CH}_3)_2$), 32.32 ($\text{CH}(\text{CH}_3)_2^*$), 28.44 (4-*C*), 25.64 (5-*C*), 25.52 (4-*C**), 23.41 (5-*C**), 17.97 ($\text{CH}(\text{CH}_3)_2^*$), 17.68 ($\text{CH}(\text{CH}_3)_2$), 17.61 ($\text{CH}(\text{CH}_3)_2$ and $\text{CH}(\text{CH}_3)_2^*$), 17.38 (9-*C*), 16.11 (9-*C**); m/z (EI)(both isomers) 156 (M^+ , 18 %), 114 (21 %), 113 ($\text{M}^+ - \text{Pr}$, 56 %), 97 (8 %), 86 (10 %), 84 (80 %).

*Data for minor diastereoisomer.

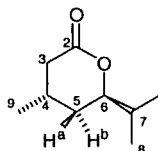

Further elution gave pure (±)-(6S*,4S*) 6-isopropyl-4-methyl-tetrahydro-pyran-2-one **318** as a clear oil (5 mg, 15 %); R_f (pet. ether/ether [1:1]) 0.33; ν_{\max} (thin film) 2961, 2930, 2875, 1740 (C=O), 1464, 1388, 1371, 1282, 1250, 1237, 1183, 1084, 1066, 1002 cm^{-1} ; δ_H (500 MHz; CDCl_3) 4.08 (1 H, ddd, J 10.5, 6.5, 4.0, 6-*H*), 2.55 (1 H, dd, J 9.0, 9.0, 3-*HH*), 2.18 (2 H, m, 3-*HH* and 4-*H*), 1.87 (1 H, oct, J 6.5, $\text{CH}(\text{CH}_3)_2$), 1.83 (1 H, ddd, J 14.0, 10.5, 7.0, 5a-*H*), 1.52 (1 H, ddd, J 14.0, 5.5, 4.0, 5b-*H*), 1.10 (3 H, d, J 6.5, 9-*H*₃), 1.01 (3 H, d, J 6.5, $\text{CH}(\text{CH}_3)_2$), 0.95 (3 H, d, J 6.5, $\text{CH}(\text{CH}_3)_2$); δ_C (101 MHz; CDCl_3) 172.91 (C=O), 81.61

(6-*C*), 37.28 (3-*C*), 32.43 (CH(CH₃)₂), 31.94 (5-*C*), 23.89 (4-*C*), 21.37 (9-*C*), 18.07 (CH(CH₃)₂), 18.02 (CH(CH₃)₂); *m/z* (EI) 156 (M⁺, 19 %), 138 (3 %), 128 (15 %), 114 (24 %), 113 (M⁺-ⁱPr, 97 %), 86 (12 %), 85 (100 %); all data from which agrees with that given in the literature.¹⁸⁰

1-phenyl-1-trimethylsilyl-2-(prop-2'-yl)-3,5-dimethylsilacyclohex-4-ene 319-320

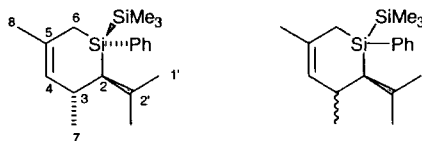

• Method 1¹⁰

Methylolithium (1.6 M solution in ether, 2.54 ml, 4.07 mmol) was added to a stirred solution of silyl alcohol **182** (1.32 g, 4.07 mmol) and *trans*-2-methyl-1,3-pentadiene (1 g, 12.20 mmol) in ether (45 ml) at -78 °C. The mixture was allowed to warm to -30 °C and stirred for 20 h. Saturated ammonium chloride solution (40 ml) was added and the mixture allowed to reach RT. The aqueous layer was separated and extracted with ether (3 x 40 ml). The combined organic layers were dried over MgSO₄, filtered, concentrated and dried *in vacuo*. Flash column chromatography (pet. ether) gave the title compound as a colourless oil (0.122 g, 9 %) together with small amounts of diastereoisomers in a ratio of 94 : 5 : 1 % (ratio of product peak integrals by GC).

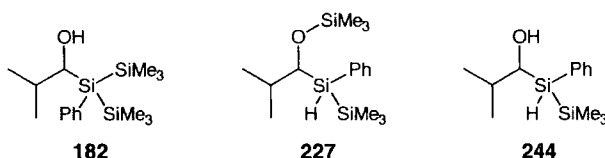

Further elution (pet. ether/ether [19:1]) gave a mixture of starting material **182**, 1-phenyl-1,1,1-trimethylsilyl-2-(1'-trimethylsilyloxy-2'-methylpropyl)silane **227** and 1,1,1-trimethyl-2-phenyl-2-(1'-hydroxy-2'-methylpropyl)silane **244** (0.85 g, ~64 %, (81 : 14 : 5)).

• Method 2

n-Butyllithium (1.6 M solution in hexane, 3.42 ml, 5.46 mmol) was added to a stirred solution of silyl alcohol **182** (1.75 g, 5.41 mmol) and 2-methyl-1,3-pentadiene (3.71 ml, 32.46 mmol) in dry ether (78 ml) at RT. The mixture was stirred for 3 h, then cooled to -45 °C. An anhydrous solution of LiBr in ether (0.31 M, 0.85 ml, 0.27 mmol) was added. The mixture was warmed to -30 °C and stirred for 18 h after which time saturated ammonium chloride solution (78 ml) was added and the mixture allowed to reach RT. The aqueous layer was separated and extracted with ether (3 x 78 ml). The combined organic layers were dried over MgSO₄, filtered, concentrated and dried *in vacuo*. Flash column chromatography

(pet. ether) gave the title compounds as a colourless oil (0.75 g, 44 %); R_f (pet. ether) 0.77 as a mixture of isomers in a ratio of 80 : 14 : 4 : 2 % (ratio of product peak integrals by GC); ν_{\max} (thin film) 2956, 2928, 2900, 2868, 1427, 1244, 1101, 855, 833, 725, 697 cm^{-1} ; NMR data for the major isomer **319**: δ_H (400 MHz; CDCl_3) 7.51-7.49 (2 H, m, Ar-*H*), 7.33-7.30 (3 H, m, Ar-*H*), 5.32 (1 H, m, 4-*H*), 2.33 (1 H, m, 3-*H*), 2.10 (1 H, m, $\text{CH}(\text{CH}_3)_2$), 1.82 (3 H, s, 8-*H*₃), 1.64 (1 H, d, J 16.8, 6-*HH*), 1.43 (1 H, d, J 16.8, 6-*HH*), 1.14 (1 H, ddd, J 6.4, 3.2, 0.8, 2-*H*), 1.03 (3 H, d, J 6.8, $\text{CH}(\text{CH}_3)_2$), 0.95 (3 H, d, J 6.8, 7-*H*₃), 0.89 (3 H, d, J 6.8, $\text{CH}(\text{CH}_3)_2$), 0.16 (9 H, s, $\text{Si}(\text{CH}_3)_3$); δ_C (101 MHz; CDCl_3) 139.71 (5-*C*), 135.20 (*ipso* Ar), 134.40 (Ar), 131.17 (4-*C*), 128.15 (Ar), 127.62 (Ar), 38.38 (2-*C*), 33.05 (3-*C*), 29.64 (2'-*C*), 28.27 (8-*C*), 23.56 (7-*C*), 22.81 (1'-*C* (x2)), 15.05 (6-*C*), 0.44 ($\text{Si}(\text{CH}_3)_3$); m/z (GCMS, EI) 316 (M^+ , 43 %), 301 (M^+ -Me, 4 %), 273 (M^+ -^{*i*}Pr, 3 %), 259 (6 %), 245 (27 %), 243 (M^+ -SiMe₃, 93 %), 232 (17 %), 219 (56 %), 217 (45 %), 201 (86 %), 187 (87 %), 161 (100 %), 135 (79 %), 121 (81 %), 109 (84 %); HRMS (EI⁺) Found: 316.2038 ($\text{C}_{19}\text{H}_{32}\text{Si}_2$ (M^+) requires 316.2043).

3,5-dimethyl-1-phenyl-6-(prop-2'-yl)-1-trimethylsilyl-silacyclohexane **321-323**

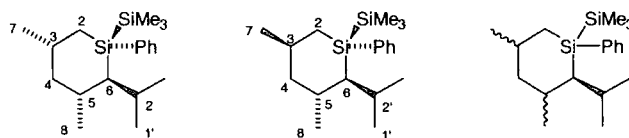

A mixture of silacycles **319-320** (0.75 g, 2.36 mmol) and platinum dioxide hydrate (30 mg, 0.122 mmol) in ethyl acetate (22 ml) was repeatedly evacuated and flushed with hydrogen from a balloon.^{175, 177} The mixture was then stirred under the hydrogen atmosphere for several days, but TLC at this time showed incomplete consumption of starting material. It was therefore filtered through a celite pad and washed through with ethyl acetate. Part of the solvent was removed in vacuo and the reaction begun again with platinum dioxide hydrate (24 mg, 0.098 mmol) and hydrogen. After stirring for 20 h, TLC showed complete consumption of starting material and formation of product. The reaction mixture was concentrated and dried *in vacuo*. Flash column chromatography (pet. ether) gave the product as a mixture of 5 isomers (0.56 g, 74 %); in a ratio of 44 : 39 : 9 : 6 : 1 : 1 % (ratio of product peak integrals by GC); R_f (pet. ether) 0.86; m/z (GCMS, EI) 318 (M^+ , 13 %), 303 (M^+ -Me, 1 %), 245 (M^+ -SiMe₃, 80 %), 203 (34 %), 189 (34 %), 175 (48 %), 161 (100 %), 147 (27 %), 135 (52 %), 125 (45 %), 121 (71 %).

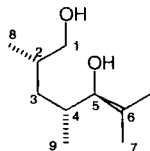
(±)-(2S*,4R*,5S*),2,4,6-trimethylheptane-1,5-diol 324

- **Stage 1**

To a solution of silacycle mixture **321-323** (0.37 g, 1.17 mmol) in dry chloroform (21 ml) was added trifluoroborane-acetic acid complex (3.25 ml, 23.4 mmol).¹⁰ The mixture was then heated to reflux and stirred for 19 h. The solution was then allowed to cool to RT and saturated sodium hydrogen carbonate solution (25 ml) was added. The aqueous layer was separated and extracted with DCM (3 x 25 ml). The combined organic layers were then dried over MgSO₄, filtered, concentrated and dried *in vacuo* to give an orange oil which was used immediately in stage 2.

- **Stage 2**

To the orange oil was added potassium hydrogen carbonate (0.45 g, 4.51 mmol) and potassium fluoride (0.27 g, 4.66 mmol). The mixture was dissolved in THF/MeOH solution (1:1, 22 ml) and hydrogen peroxide (35 % w/w solution in water, 2.8 ml, 27.9 mmol) was added. The mixture was heated to reflux and stirred for 20 h.¹⁰ The mixture was then allowed to cool to RT and saturated sodium thiosulfate solution (22 ml) was added. The aqueous layer was separated and extracted with ethyl acetate (3 x 22 ml). The combined organic extracts were dried over MgSO₄, filtered, concentrated and dried *in vacuo*. Flash column chromatography (pet. ether/ethyl acetate [3:2]) gave the pure title compound as a thick colourless oil (0.02 g, 10 %); R_f (pet. ether/ethyl acetate [1:1]) 0.47; ν_{max} (thin film) 3362 (broad, O-H), 2957, 2927, 2872, 1464, 1460, 1385, 1090 cm⁻¹; δ_H (500 MHz; CDCl₃) 3.53 (1 H, dd, J 5.0, 11.0, 1-HH), 3.50 (1 H, dd, J 5.0, 11.0, 1-HH), 3.07 (1 H, dd, J 6.5, 5.0, 5-H), 1.81 (1 H, septet d, J 6.5, 1.5, 6-H), 1.72 (1 H, m, 2-H), 1.65 (1 H, m, 4-H), 1.24 (2 H, m, 3-H₂), 0.97 (3 H, d, J 7.0, 8-H₃), 0.93 (3 H, d, J 7.0, CH(CH₃)₂), 0.90 (3 H, d, J 7.0, 9-H₃), 0.88 (3 H, d, J 7.0, CH(CH₃)₂); δ_C (126 MHz; CDCl₃) 81.73 (5-C), 67.03 (1-C), 36.03 (3-C), 33.72 (4-C), 33.42 (2-C), 29.92 (6-C), 20.04 (CH(CH₃)₂), 18.75 (8-C), 17.42 (9-C), 15.82 (CH(CH₃)₂); m/z (ES⁺) 197 (M+Na⁺, 100 %); HRMS (ES⁺) Found: 192.1955 (C₁₀H₂₆O₂N (M+NH₄⁺) requires 192.1958).

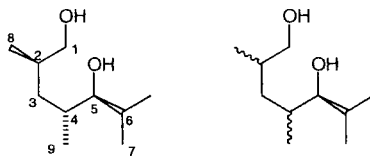

Further elution gave an inseparable mixture of diastereoisomers of 2,4,6-trimethylheptane-1,5-diol **325-326** as a clear oil (0.02 g, 10 %); R_f (pet. ether/ethyl acetate [1:1]) 0.32; ν_{\max} (thin film) 3353 (broad, O-H), 2961, 2935, 2877, 1468, 1385, 1076, 1050 cm^{-1} ; NMR data for the major isomer **325**: δ_H (500 MHz; CDCl_3) 3.45 (2 H, d, J 6.0, 1- H_2), 3.08 (1 H, d, J 6.0, 5- H), 1.80 (1 H, oct, 6- H), 1.75 (1 H, m, 2- H), 1.71 (1 H, m, 4- H), 1.34 (1 H, ddd, J 13.0, 10.0, 3.5, 3- HH), 1.25 (1 H, ddd, J 13.0, 10.0, 1.5, 3- HH), 0.92 (3 H, d, J 7.0, $\text{CH}(\text{CH}_3)_2$), 0.91 (3 H, d, J 7.0, $\text{CH}(\text{CH}_3)_2$), 0.90 (3 H, d, J 4.5, 9- H_3), 0.88 (3 H, d, J 4.0, 8- H_3); δ_C (126 MHz; CDCl_3) 81.56 (5- C), 69.13 (1- C), 34.30 (3- C), 32.94 (2- C), 32.48 (4- C), 30.09 (6- C), 19.85 ($\text{CH}(\text{CH}_3)_2$), 16.68 (9- C), 16.59 ($\text{CH}(\text{CH}_3)_2$), 16.00 (8- C); m/z (ES^+) 197 ($\text{M}+\text{Na}^+$); HRMS (ES^+) Found: 192.1961 ($\text{C}_{10}\text{H}_{26}\text{O}_2\text{N}$ ($\text{M}+\text{NH}_4^+$) requires 192.1958).

(±)-(6S*,3S*,5R*) 6-Isopropyl-3,5-dimethyl-tetrahydro-pyran-2-one 327

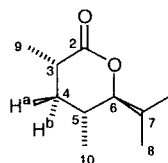

To a solution of diol **324** (20 mg, 0.115 mmol) in dry DCM (2 ml) was added powdered molecular sieves (4 Å, approx. 0.3 g), NMO (53 mg, 0.45 mmol) and TPAP (1.5 mg, 0.043 mmol).¹⁶⁸⁻¹⁷⁰ The mixture was stirred at RT for 25 h. It was then diluted with ether, filtered through silica and washed through with more ether. The filtrate was concentrated under reduced pressure. [High vacuum was not used as the product is volatile]. Flash column chromatography (pet. ether/ether [1:1]) gave the pure title compound as a clear oil (9 mg, 45 %); R_f (pet. ether/ether [1:1]) 0.68; ν_{\max} (thin film) 2965, 2935, 2877, 1731 (C=O), 1462, 1380, 1356, 1333, 1215, 1192, 1171, 1121, 1099, 1076, 1041, 996 cm^{-1} ; δ_H (500 MHz; CDCl_3) 3.83 (1 H, dd, J 10.5, 2.0, 6- H), 2.47 (1 H, m, 3- H), 1.94 (1 H, sept d, J 7.0, 2.0, $\text{CH}(\text{CH}_3)_2$), 1.92-1.82 (2 H, m, 4b- H and 5- H), 1.46 (1 H, q, J 13.0, 4a- H), 1.27 (3 H, d, J 7.0, 9- H_3), 1.08 (3 H, d, J 7.0, $\text{CH}(\text{CH}_3)_2$), 0.96 (3 H, d, J 7.0, 10- H_3), 0.89 (3 H, d, J 7.0, $\text{CH}(\text{CH}_3)_2$); δ_C (126 MHz; CDCl_3) 174.92 (C=O), 90.95 (6- C), 37.66 (4- C), 36.25 (3- C), 31.14 ($\text{CH}(\text{CH}_3)_2$), 29.34 (5- C), 19.94 ($\text{CH}(\text{CH}_3)_2$), 17.30 (9- C and 10- C), 14.15 ($\text{CH}(\text{CH}_3)_2$); m/z (EI) 170 (M^+ , 8 %), 142 (2 %), 129 (4 %), 127 ($\text{M}^+ - i\text{Pr}$, 80 %), 100 (12 %), 99 (71 %); all data from which agrees with that given in the literature.^{181, 182}

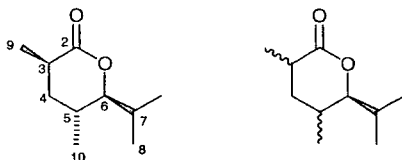
(±)-(6S*,3R*,5R*) 6-Isopropyl-3,5-dimethyl-tetrahydro-pyran-2-one 328-329

To a solution of diol mixture **325-326** (48 mg, 0.28 mmol) in dry DCM (4 ml) was added powdered molecular sieves (4 Å, approx. 0.3 g), NMO (127 mg, 1.08 mmol) and TPAP (3.6 mg, 0.010 mmol).¹⁶⁸⁻¹⁷⁰ The mixture was stirred at RT for 25 h. It was then diluted with ether, filtered through silica and washed through with more ether. The filtrate was concentrated under reduced pressure. [High vacuum was not used as the product is volatile]. Flash column chromatography (pet. ether/ether [1:1]) gave the title compounds as a clear oil (12 mg, 26 %); R_f (pet. ether/ether [1:1]) 0.63; as a mixture in a ratio of 79 : 11 : 8 : 2 % (ratio of product peak integrals by GC); ν_{\max} (thin film) 2966, 2934, 2875, 1743 (C=O), 1459, 1379, 1329, 1199, 1147, 1113, 1093, 1023, 997 cm^{-1} ; NMR data for the major isomer **328**: δ_H (500 MHz; CDCl_3) 3.80 (1 H, dd, J 10.0, 2.5, 6- H), 2.62 (1 H, d pent, J 8.5, 7.0, 3- H), 1.94 (1 H, m, 5- H), 1.90 (1 H, sept d, J 7.0, 2.5, $\text{CH}(\text{CH}_3)_2$), 1.68-1.64 (2 H, m, 4- H_2), 1.20 (3 H, d, J 7.0, 9- H_3), 1.06 (3 H, d, J 7.0, $\text{CH}(\text{CH}_3)_2$), 0.97 (3 H, d, J 7.0, 10- H_3), 0.92 (3 H, d, J 7.0, $\text{CH}(\text{CH}_3)_2$); δ_C (126 MHz; CDCl_3) 176.75 (C=O), 87.24 (6- C), 35.17 (4- C), 32.40 (3- C), 28.97 ($\text{CH}(\text{CH}_3)_2$), 28.59 (5- C), 19.95 ($\text{CH}(\text{CH}_3)_2$), 17.67 (10- C), 16.45 (9- C), 14.28 ($\text{CH}(\text{CH}_3)_2$); m/z (EI) 170 (M^+ , 10 %), 142 (2 %), 129 (4 %), 127 ($\text{M}^+ - i\text{Pr}$, 81 %), 100 (15 %), 98 (76 %).

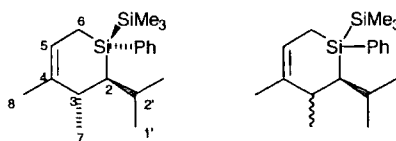
1-phenyl-1-trimethylsilyl-2-(prop-2'-yl)-3,4-dimethylsilacyclohex-4-ene 330-331

n-Butyllithium (1.6 M solution in hexane, 2.02 ml, 3.23 mmol) was added to a stirred solution of silyl alcohol **182** (1.04 g, 3.20 mmol) and *trans*-3-methyl-1,3-pentadiene (2.16 g, 19.19 mmol) in dry ether (47 ml) at RT. The mixture was stirred for 3 h after which time TLC showed complete consumption of starting material. The solution was cooled to $-45\text{ }^\circ\text{C}$ and an anhydrous solution of LiBr in ether (0.31 M, 0.51 ml, 0.16 mmol) was added. The mixture was warmed to $-30\text{ }^\circ\text{C}$ and stirred for 23 h. Saturated ammonium chloride solution (47 ml) was added and the mixture allowed to reach RT. The aqueous layer was separated and extracted with ether (3 x 47 ml). The combined organic layers were dried over MgSO_4 , filtered, concentrated and dried *in vacuo*. Flash column chromatography (pet. ether) gave the title compounds as a colourless oil (0.35 g, 38 %); R_f (pet. ether) 0.75 as a mixture of

four isomers in a ratio of 86 : 9 : 4 : 1 % (ratio of product peak integrals by GC); ν_{\max} (thin film) 2955, 2926, 2891, 2869, 1427, 1382, 1243, 1099, 1057, 1027, 854, 833, 699 cm^{-1} ; NMR and MS data for the major isomer **330**: δ_{H} (500 MHz; CDCl_3) 7.51-7.49 (2 H, m, *meta* Ar-H), 7.33-7.29 (3 H, m, *ortho* and *para* Ar-H), 5.56 (1 H, ddd, J 7.5, 4.0, 1.5, 5-H), 2.24 (1 H, qd, J 7.0, 2.5, 3-H), 2.00 (1 H, m, $\text{CH}(\text{CH}_3)_2$), 1.72 (3 H, s, 8- H_3), 1.71 (1 H, m, 6-HH), 1.55 (1 H, dd, J 15.5, 7.5, 6-HH), 1.24 (1 H, dd, J 5.0, 2.5, 2-H), 1.03 (3 H, d, J 7.0, $\text{CH}(\text{CH}_3)_2$), 0.93 (3 H, d, J 7.0, $\text{CH}(\text{CH}_3)_2$), 0.92 (3 H, d, J 7.0, 7- H_3), 0.09 (9 H, s, $\text{Si}(\text{CH}_3)_3$); δ_{C} (101 MHz; CDCl_3) 142.52 (5-C or *ipso* Ar), 140.16 (5-C or *ipso* Ar), 134.17 (Ar), 128.06 (Ar), 127.64 (Ar), 118.76 (Ar), 39.08 (2-C), 37.66 (3-C), 31.70 (2'-C), 24.95 (8-C), 24.06 (1'-C), 22.42 (7-C), 21.88 (1'-C), 9.32 (6-C), -0.72 ($\text{Si}(\text{CH}_3)_3$); m/z (GCMS, EI) 316 (M^+ , 7 %), 243 ($\text{M}^+ - \text{SiMe}_3$, 65 %), 217 (10 %), 215 (12 %), 187 (47 %), 161 (100 %), 135 (38 %), 121 (40 %), 110 (22 %), 105 (PhSi^+ , 29 %); HRMS (EI) Found: 316.2039 ($\text{C}_{19}\text{H}_{32}\text{Si}_2$ (M^+) requires 316.2037).

4,5-dimethyl-1-phenyl-6-(prop-2'-yl)-1-trimethylsilyl-silacyclohexane 332-334

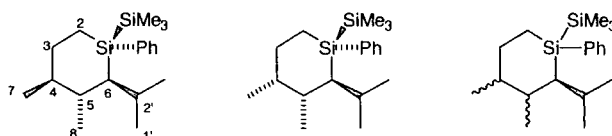

2.2 ml of a solution of $\text{Ir}(\text{P}(\text{C}_6\text{H}_{11})_3)(\text{cod})\text{pyr.PF}_6$ (207 mg, 0.257 mmol) in dry, degassed (freeze-pump-thaw method) DCM (10.3 ml) was added to a solution of silacycle mixture **330-331** (0.34 g, 1.08 mmol) in dry, degassed DCM (45 ml) under nitrogen. The vessel was repeatedly evacuated and flushed with hydrogen from a balloon and the mixture was stirred for 1 h. Another 2.2 ml of catalyst solution was added and stirred for 1 h. This was repeated twice more and stirred for 20 h. The remaining catalyst solution (1.5 ml) was added and the solution stirred for 160 h while the reaction was followed by TLC. The mixture was then concentrated in vacuo and pet. ether was added to form a suspension of the catalyst. This was filtered through celite and washed with pet. ether. The filtrate was concentrated and dried in vacuo. Flash column chromatography (pet. ether) gave the title compounds as a colourless oil (0.12 g, 35 %); R_f (pet. ether) 0.88 as a mixture of isomers in a ratio of 66 : 26 : 5 : 2 : 1 % (ratio of product peak integrals by GC); m/z (GCMS, EI) 318 (M^+ , 24 %), 303 ($\text{M}^+ - \text{Me}$, 2 %), 245 ($\text{M}^+ - \text{SiMe}_3$, 100 %), 217 (8 %), 203 (14 %), 189 (38 %), 175 (87 %), 161 (89 %), 135 (79 %), 121 (90 %).

Further elution gave starting silacycles **330-331** (0.07 g, 19 %).

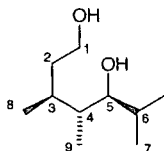
(±)-(3S*,4R*,5S*) 3,4,6-trimethylheptane-1,5-diol 335

- **Stage 1**

To a solution of silacycle mixture **332-334** (0.12 g, 0.38 mmol) in dry chloroform (5 ml) was added trifluoroborane-acetic acid complex (1.02 ml, 7.55 mmol).¹⁰ The mixture was then heated to reflux and stirred for 16 h. The solution was then allowed to cool to RT and saturated sodium hydrogen carbonate solution (7 ml) was added. The aqueous layer was separated and extracted with DCM (3 x 7 ml). The combined organic layers were then dried over MgSO₄, filtered, concentrated and dried *in vacuo* to give an orange oil which was used immediately in stage 2.

- **Stage 2**

To the orange oil was added potassium hydrogen carbonate (0.15 g, 1.45 mmol) and potassium fluoride (0.09 g, 1.50 mmol). The mixture was dissolved in THF/MeOH solution (1:1, 3 ml) and hydrogen peroxide (35 % w/w solution in water, 0.9 ml, 8.99 mmol) was added. The mixture was heated to reflux and stirred for 3 h.¹⁰ The mixture was then allowed to cool to RT and saturated sodium thiosulfate solution (10 ml) and ethyl acetate (10 ml) was added. The aqueous layer was separated and extracted with ethyl acetate (3 x 10 ml). The combined organic extracts were dried over MgSO₄, filtered, concentrated and dried *in vacuo*. Flash column chromatography (pet. ether/ethyl acetate [3:2]) gave the pure title compound as a thick colourless oil (7 mg, 11 %); *R_f* (pet. ether/ethyl acetate [1:1]) 0.28; *v*_{max} (thin film) 3358 (broad, O-H), 2959, 2931, 2875, 1463, 1383, 1367, 1058, 992 cm⁻¹; *δ*_H (500 MHz; CDCl₃) 3.76 (1 H, ddd, J 10.5, 6.5, 5.0, 1-HH), 3.63 (1 H, dd, J 10.5, 9.0, 5.5, 1-HH), 3.29 (1 H, dd, J 10.0, 2.5, 5-H), 2.11 (1 H, m, 3-H), 1.84 (1 H, sept d, J 7.0, 2.5, 6-H), 1.71 (1 H, m, 2-HH), 1.53 (1 H, m, 4-H), 1.21 (1 H, m, 2-HH), 1.00 (3 H, d, J 7.0, CH(CH₃)₂), 0.96 (3 H, d, J 7.0, 8-H₃), 0.83 (3 H, d, J 7.0, CH(CH₃)₂), 0.74 (3 H, d, J 7.0, 9-H₃); *δ*_C (126 MHz; CDCl₃) 77.59 (5-C), 61.88 (1-C), 41.01 (4-C), 33.26 (3-C), 29.36 (2-C), 28.61 (6-C), 20.82 (CH(CH₃)₂), 19.15 (8-C), 13.94 (CH(CH₃)₂), 10.50 (9-C); *m/z* (ES⁺) 197 (M+Na⁺, 100 %); HRMS (ES⁺) Found: 197.1527 (C₁₀H₂₂O₂Na (M+Na⁺) requires 197.1517).

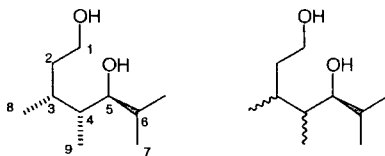

Further elution gave a mixture of diastereoisomers of 3,4,6-trimethylheptane-1,5-diol **336-337** as a clear oil (5 mg, 7 %); R_f (pet. ether/ethyl acetate [1:1]) 0.13; ν_{\max} (thin film) 3352 (broad, O-H), 2959, 2925, 2875, 1455, 1384, 1059, 988 cm^{-1} ; NMR data for major isomer **336**: δ_H (500 MHz; CDCl_3) 3.72 (1 H, dt, J 10.5, 7.0, 1- HH), 3.69 (1 H, dt, J 10.5, 7.0, 1- HH), 3.26 (1 H, dd, J 2.5, 10.0, 5- H), 2.15 (1 H, hex d, J 7.0, 2.5, 3- H), 1.83 (1 H, sept d, J 7.0, 2.5, 6- H), 1.56-1.50 (3 H, m, 2- H_2 and 4- H), 1.00 (3 H, d, J 7.0, $\text{CH}(\text{CH}_3)_2$), 0.82 (3 H, d, J 7.0, $\text{CH}(\text{CH}_3)_2$), 0.81 (3 H, d, J 7.0, 8- H_3), 0.71 (3 H, d, J 7.0, 9- H_3); δ_C (126 MHz; CDCl_3) 77.51 (5- C), 61.29 (1- C), 39.43 (3- C), 38.72 (6- C), 29.27 (2- C), 27.98 (4- C), 20.67 ($\text{CH}(\text{CH}_3)_2$), 13.69 ($\text{CH}(\text{CH}_3)_2$), 13.40 (8- C), 9.71 (9- C); m/z (ES^+) 197 ($\text{M}+\text{Na}^+$); HRMS (ES^+) Found: 197.1525 ($\text{C}_{10}\text{H}_{22}\text{O}_2\text{Na}$ ($\text{M}+\text{Na}^+$) requires 197.1517).

(±)-(6R*,4R*,5S*) 6-Isopropyl-4,5-dimethyl-tetrahydro-pyran-2-one 338

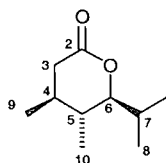

To a solution of diol **335** (8 mg, 0.046 mmol) in dry DCM (1 ml) was added powdered molecular sieves (4 Å, approx. 0.1 g), NMO (21 mg, 0.180 mmol) and TPAP (0.6 mg, 0.0017 mmol).¹⁶⁸⁻¹⁷⁰ The mixture was stirred at RT for 18 h. It was then concentrated under reduced pressure. [High vacuum was not used as the product is volatile]. Flash column chromatography (pet. ether/ether [2:1]) gave the pure title compound as a clear oil (1 mg, 13 %); R_f (pet. ether/ether [1:1]) 0.35; ν_{\max} (thin film) 2961, 2929, 2875, 2857, 1739 ($\text{C}=\text{O}$), 1462, 1378, 1247, 1197, 1114, 1013 cm^{-1} ; δ_H (500 MHz; CDCl_3) 3.83 (1 H, dd, J 10.0, 2.0, 6- H), 2.67 (1 H, dd, J 17.0, 6.0, 3eq- H), 2.12 (1 H, dd, J 17.0, 9.0, 3ax- H), 1.97 (1 H, sept d, J 7.0, 2.0, $\text{CH}(\text{CH}_3)_2$), 1.69 (1 H, m, 4- H), 1.38 (1 H, m, 5- H), 1.09 (3 H, d, J 7.0, $\text{CH}(\text{CH}_3)_2$), 1.02 (3 H, d, J 7.0, 9- H_3), 0.97 (3 H, d, J 7.0, 10- H_3), 0.89 (3 H, d, J 7.0, $\text{CH}(\text{CH}_3)_2$); δ_C (126 MHz; CDCl_3) 172.31 ($\text{C}=\text{O}$), 88.88 (6- C), 37.65 (3 or $\text{CH}(\text{CH}_3)_2$), 37.50 (3 or $\text{CH}(\text{CH}_3)_2$), 32.84 (4- C), 29.07 (5- C), 20.10 ($\text{CH}(\text{CH}_3)_2$), 19.99 (9- C), 14.83 (10- C), 13.96 ($\text{CH}(\text{CH}_3)_2$); m/z (EI) 170 (M^+ , 6 %), 152 (6 %), 142 (8 %), 128 (14 %), 127 (M^+ - ^iPr , 100 %), 109 (7 %), 99 (42 %), 98 (50 %).

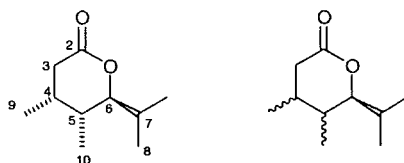
(±)-(6R*,4S*,5S*) 6-Isopropyl-4,5-dimethyl-tetrahydro-pyran-2-one 339-340

To a solution of diol mixture **336-337** (5 mg, 0.029 mmol) in dry DCM (1 ml) was added powdered molecular sieves (4 Å, approx. 0.1 g), NMO (13 mg, 0.114 mmol) and TPAP (0.4 mg, 0.0011 mmol).¹⁶⁸⁻¹⁷⁰ The mixture was stirred at RT for 20 h. It was then concentrated under reduced pressure. [High vacuum was not used as the product is volatile]. Flash column chromatography (pet. ether/ether [2:1]) gave the title compounds as a clear oil (3 mg, 60 %); R_f (pet. ether/ether [1:1]) 0.44 as a mixture of isomers in the ratio 87 : 10 : 3 % (ratio of product peak integrals by GC); ν_{\max} (thin film) 2963, 2930, 2878, 1734 (C=O), 1456, 1389, 1237, 1216, 1110, 1085, 1022, 990 cm^{-1} ; NMR data for major isomer **336**: δ_H (500 MHz; CDCl_3) 3.95 (1 H, dd, J 9.0, 4.0, 6-*H*), 2.55 (1 H, dd, J 17.5, 6.0, 3ax-*H*), 2.35 (1 H, dd, J 17.5, 5.0, 3eq-*H*), 2.08 (1 H, m, 4-*H*), 1.95 (1 H, m, 5-*H*), 1.88 (1 H, sept d, J 7.0, 4.0, $\text{CH}(\text{CH}_3)_2$), 1.05 (3 H, d, J 7.0, $\text{CH}(\text{CH}_3)_2$), 0.99 (3 H, d, J 7.0, 9- H_3), 0.96 (3 H, d, J 7.0, 10- H_3), 0.93 (3 H, d, J 7.0, $\text{CH}(\text{CH}_3)_2$); δ_C (126 MHz; CDCl_3) 171.77 (C=O), 86.94 (6-*C*), 37.47 (3-*C*), 32.67 (5-*C*), 29.94 ($\text{CH}(\text{CH}_3)_2$), 29.49 (4-*C*), 19.83 ($\text{CH}(\text{CH}_3)_2$), 15.30 ($\text{CH}(\text{CH}_3)_2$), 14.83 (9-*C*), 14.21 (10-*C*); m/z (EI) 170 (M^+ , 8 %), 152 (9 %), 142 (14 %), 128 (21 %), 127 ($\text{M}^+ - \text{Pr}$, 67 %), 109 (9 %), 99 (48 %), 98 (49 %).

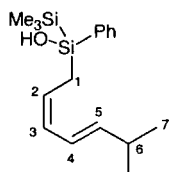
1-(1'-Hydroxy-1'-phenyl-1'-trimethylsilyl)silyl-6-methyl-2,4-heptadiene 342

Methylolithium (1.6 M solution in ether, 1.28 ml, 2.04 mmol) was added to a stirred solution of silyl alcohol **182** (0.661 g, 2.04 mmol) and 1-methoxy-1,3-butadiene (1.00 g, 12.2 mmol) in ether (20 ml) at -78°C . The mixture was allowed to warm to -30°C and stirred for 19 h.¹⁰ Saturated ammonium chloride solution (25 ml) was added and the mixture allowed to reach RT. The aqueous layer was separated and extracted with ether (3 x 25 ml). The combined organic layers were dried over MgSO_4 , filtered, concentrated and dried *in vacuo*. Flash column chromatography, gradient elution (pet. ether; pet. ether/ether [39:1]; [29:1]; [19:1]; [9:1]; [4:1]; ether) gave the starting material silyl alcohol **182** (0.320 g, 48 %).

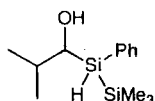

This was followed by 1,1,1-trimethyl-2-phenyl-2-(1'-hydroxy-2'-methylpropyl)silane **244** (0.047 g, 9 %); R_f (pet. Ether/ether [9:1]) 0.26; m.p. 43.0-44.5 °C; ν_{\max} (thin film) 3462 (broad, O-H), 2955, 2893, 2870, 2095 (Si-H), 1428, 1245, 1105, 1065, 858, 837 cm^{-1} ; δ_H (300 MHz; CDCl_3) 7.61-7.57 (2 H, m, Ar-H), 7.36-7.33 (3 H, m, Ar-H), 4.26 (1 H, d, J 3.0, Si-H), 3.60 (1 H, dd, J 4.4, 3.0, CHOH), 1.88 (1 H, septet, J 6.9, $\text{CH}(\text{CH}_3)_2$), 1.00 (3 H, d, J 6.9, $\text{CH}(\text{CH}_3)_2$), 0.96 (3 H, d, J 6.9, $\text{CH}(\text{CH}_3)_2$), 0.19 Si(CH_3)₃; δ_C (126 MHz; CDCl_3) 136.02 (Ar), 133.04 (*ipso*-Ar), 129.00 (Ar-H), 127.99 (Ar), 70.51 (CHOH), 33.40 ($\text{CH}(\text{CH}_3)_2$), 20.36 ($\text{CH}(\text{CH}_3)_2$), 19.10 ($\text{CH}(\text{CH}_3)_2$), -1.12 (Si(CH_3)₃); m/z (GCMS, CI) 237 (M^+ -Me, 9 %), 219 (M^+ -H₂O, 5 %), 195 (50 %), 194 (47 %), 181 (48 %), 179 (M^+ -SiMe₃ or PrCHOH , 52 %), 119 (96 %); HRMS (CI) Found: 270.1708 ($\text{C}_{13}\text{H}_{28}\text{NOSi}_2$ ($\text{M}+\text{NH}_4^+$) requires 270.1709).

Further elution afforded the title compound **342** as a yellow oil (0.047 g, 8 %); R_f (pet. ether) 0.70; ν_{\max} (thin film) 3069, 3049 2957, 2894, 1712, 1465, 1428, 1247, 1129, 1108, 1066, 839, 740, 699 cm^{-1} ; δ_H (300 MHz; CDCl_3) 7.55-7.52 (2 H, m, Ar-H), 7.38-7.35 (3 H, m, Ar-H), 6.21 (1 H, dd, J 15.0, 10.0, 4-H), 5.95 (1 H, t, J 10.0, 3-H), 5.61 (1 H, dd, J 15.0, 6.5, 5-H), 5.38 (1 H, q, J 10.0, 2-H), 2.32 (1 H, octet, J 6.5, 6-H), 2.14 (1 H, dd, J 14.0, 10.0, 1-H), 2.04 (1 H, dd, J 14.0, 10.0, 1-H), 0.99 (6 H, d, J 6.5, 7-H₆), 0.14 (9 H, s, Si(CH_3)₂); δ_C (126 MHz; CDCl_3) 141.46 (5-C), 138.44 (*ipso*-Ar), 133.08 (Ar), 129.26 (Ar-H), 128.12 (3-C), 127.90 (Ar), 123.92 (2-C), 122.45 (4-C), 31.35 (6-C), 22.42 (7-C), 19.65 (1-C), -2.02 (Si(CH_3)₃); m/z (GCMS, EI) 304 (M^+ , 38 %), 197 (50 %), 196 (64 %), 195 ($[\text{Ph}(\text{SiMe}_3)\text{SiOH}]^+$, 100 %), 179 ($[\text{Ph}(\text{SiMe}_3)\text{Si}]^+$, 64 %), 137 (57 %), 136 (63 %), 135 (95 %).

1,6-Dihydroxy-*trans-trans*-2,4-hexadiene **348**

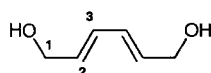

To a solution of Red-Al[®] (sodium bis(methoxyethoxy)aluminium hydride, 70 % w/w in toluene, 42.14 g, 145.9 mmol) in THF (75 ml) was added dropwise a solution of 2,4-hexadiyne-1,6-diol **347** (2.50 g, 22.7 mmol) in THF (150 ml).¹⁸⁸ The mixture was stirred for 18 h at RT. The reaction mixture was cooled to 0 °C and transferred dropwise *via* canula to a stirred saturated aqueous solution of Rochelle's salt (potassium sodium L-tartrate tetrahydrate, 227 ml). The aqueous layer was separated and extracted with ethyl acetate (3 x 60 ml). The combined organic layers were dried over MgSO₄, filtered, concentrated and dried *in vacuo*. Recrystallisation from ethyl acetate/hexane gave the title compound as pale cream needle crystals (2.098 g, 81 %); m.p. 99-100 °C (lit. 104-105 °C); ν_{\max} (thin film)

3278 (broad, OH), 2926, 2871, 1992, 1845, 1737, 1457, 1390, 1350, 1251, 1075, 1021, 989, 720 cm^{-1} ; δ_{H} (300 MHz; acetone- d_6) 6.24 (2 H, m, 2- H_2), 5.80-5.75 (2 H, m, 2- H_2), 4.09 (4 H, t, J 5.7, 1- H_4), 3.78 (2 H, t, J 5.7, OH); δ_{C} (63 MHz; acetone- d_6) 134.16 (2-C), 130.44 (3-C), 63.07 (1-C); m/z (EI) 114 (M^+ , 6 %), 96 ($\text{M}^+ - \text{H}_2\text{O}$, 46 %), 83 ($\text{M}^+ - \text{CH}_2\text{OH}$, 29 %), 67 (100 %); all data from which agrees with that given in the literature.¹⁸⁸

1,6-Dimethoxy-*trans-trans*-2,4-hexadiene 349

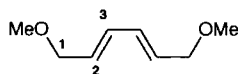

To a solution of 1,6-dihydroxy-*trans-trans*-2,4-hexadiene **348** (2.07 g, 18.2 mmol) in DMF (50 ml) was added slowly sodium hydride powder (0.51 g, 21.2 mmol) followed by methyl iodide (1.24 ml, 19.9 mmol) at 0 °C.^{189, 190} The mixture was stirred for 1 h, then a second equivalent of sodium hydride was added (0.51 g, 21.2 mmol) followed by methyl iodide (1.24 ml, 19.9 mmol) at RT. The reaction was stirred overnight at RT. Brine (17 ml) and ether (17 ml) were added dropwise. The aqueous layer was separated and extracted with ether (3 x 40 ml). The combined organic layers were washed with brine (40 ml) and water (40 ml), then dried over MgSO_4 , filtered, concentrated and dried *in vacuo*. The resulting brown oil was purified by Kugelrohr distillation to give the title compound as a clear oil (1.92 g, 74 %); b.p. 87-90 °C @ 9-12 mbar (lit. 80-85 °C @ 11 mm Hg); ν_{max} (thin film) 2984, 2926, 2890, 2821, 1466, 1451, 1378, 1361, 1190, 1113, 1103, 993 cm^{-1} ; δ_{H} (200 MHz; CDCl_3) 6.26 (2 H, m, 2- H_2), 5.82-5.69 (2 H, m, 3- H_2), 3.96 (4 H, d, J 5.4, 1- H_4), 3.33 (6 H, s, OCH_3); δ_{C} (63 MHz; CDCl_3) 131.86 (2-C), 129.77 (3-C), 72.56 (1-C), 57.85 (OCH_3); m/z (EI) 142 (M^+ , 27 %), 111 ($\text{M}^+ - \text{OMe}$, 65 %), 110 ($\text{M}^+ - \text{OMe} - \text{H}$, 93 %), 109 ($\text{M}^+ - \text{OMe} - 2\text{H}$, 93 %), 97 ($\text{M}^+ - \text{CH}_2\text{OMe}$, 100 %), 95 (91 %); all data from which agrees with that given in the literature.²⁰³

1-phenyl-1-trimethylsilyl-2-methyl-3-methylsilacyclohex-4-ene 355

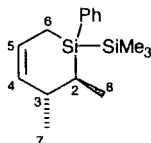

n-Butyllithium (1.6 M solution in hexane, 0.84 ml, 1.34 mmol) was added to a stirred solution of silyl alcohol **230** (0.39 g, 1.33 mmol) and 1,3-pentadiene (mixture of *cis* + *trans* isomers, 0.79 ml, 7.97 mmol) in dry ether (19 ml) at RT to give a yellow solution. The mixture was stirred for 3 h then cooled to -45 °C. An anhydrous solution of LiBr in ether (0.31 M, 0.21 ml, 0.066 mmol) was added and the mixture was warmed to -30 °C and stirred for 23 h. Saturated ammonium chloride solution (19 ml) was added and the mixture

allowed to reach RT. The aqueous layer was separated and extracted with ether (3 x 19 ml). The combined organic layers were dried over MgSO₄, filtered, concentrated and dried *in vacuo*. Flash column chromatography (pet. ether) gave the title compound as a colourless oil (0.10 g, 28 %); R_f (pet. ether) 0.58; as a mixture of isomers in a ratio of 89 : 7 : 4 % (ratio of product peak integrals by GC); ν_{\max} (thin film) 2998, 2951, 2867, 1427, 1243, 1102, 855, 833, 698 cm⁻¹; NMR data for major isomer **355**: δ_{H} (500 MHz; CDCl₃) 7.52-7.49 (2 H, m, Ar-H), 7.35-7.32 (3 H, m, Ar-H), 5.82 (1 H, m, 5-H), 5.48 (1 H, dm, J 10.5, 4-H), 2.13 (1 H, m, 3-H), 1.68 (1 H, ddd, J 18.0, 5.0, 2.0, 6-HH), 1.52 (1 H, ddd, J 18.0, 5.5, 2.0, 6-HH), 1.20 (3 H, d, J 7.5, 7-H₃), 1.08 (3 H, d, J 7.0, 8-H₃), 1.05 (1 H, m, 2-H), 0.16 (9 H, s, Si(CH₃)₃); δ_{C} (126 MHz; CDCl₃) 137.90 (*ipso*-Ar), 137.03 (4-C), 134.44 (*meta*-Ar), 128.53 (*para*-Ar), 127.76 (*ortho*-Ar), 124.12 (5-C), 38.00 (3-C), 23.87 (2-C), 21.35 (8-C), 15.97 (7-C), 9.70 (6-C), -0.50 (Si(CH₃)₃); *m/z* (GCMS, EI) 274 (M⁺, 42 %), 259 (M⁺-Me, 30 %), 245 (7 %), 231 (12 %), 218 (56 %), 203 (91 %), 200 (M⁺-H-SiMe₃, 95 %), 191 (73 %), 179 (48 %), 177 (51 %), 175 (57 %), 173 (56 %), 163 (46 %), 158 (78 %); HRMS (EI) Found: 274.1567 (C₁₆H₂₆Si₂ (M⁺) requires 274.1568).

1-phenyl-1-trimethylsilyl-2-methyl-3-methylsilacyclohexane **356**

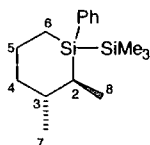

A mixture of silacycle **355** (48 mg, 0.175 mmol), Pd on carbon (10 % Pd, approx. 3 mg) in dry toluene (2 ml) was repeatedly evacuated and flushed with hydrogen from a balloon. The mixture was then stirred under the hydrogen atmosphere for 6 h.¹⁰ It was then filtered through a celite pad and washed through with ether (10 ml). The filtrate was concentrated and dried *in vacuo* to give the title compound as a colourless oil (43 mg, 90 %) as a mixture of four isomers in a ratio of 80 : 10 : 5 : 5 % (ratio of product peak integrals by GC); ν_{\max} (thin film) 3067, 3049, 2949, 2921, 2906, 2866, 2852, 1454, 1427, 1376, 1258, 1243, 1169, 1101, 1047, 851, 833, 791, 731, 698, 666 cm⁻¹; NMR data for major isomer **356**: δ_{H} (500 MHz; CDCl₃) 7.51-7.49 (2 H, m, *meta* Ar-H), 7.33-7.32 (3 H, m, *ortho* and *para* Ar-H), 2.05 (1 H, m, 5-HH), 1.73 (1 H, dq, J 14.0, 2.5, 2-H), 1.55-1.44 (2 H, m, 4-HH and 5-HH), 1.19 (3 H, d, J 7.5, 8-H₃), 1.16 (1 H, m, 6-HH), 1.03 (1 H, m, 4-HH), 1.00 (3 H, d, J 7.5, 7-H₃), 0.94-0.82 (2 H, m, 6-HH and 3-H), 0.18 (9 H, s, Si(CH₃)₃); δ_{C} (126 MHz; CDCl₃) 138.66 (*ipso*-Ar), 134.32 (*meta*-Ar), 128.34 (*para*-Ar), 127.70 (*ortho*-Ar), 39.03 (4-C), 38.76 (2-C), 26.23 (3-C), 24.37 (5-C), 21.77 (7-C), 15.90 (8-C), 12.06 (6-C), 0.18 (Si(CH₃)₃); *m/z* (EI) 276 (M⁺, 78 %), 261 (M⁺-Me, 9 %), 203 (M⁺-SiMe₃, 100 %), 187 (28 %), 175 (81 %),

161 (76 %), 147 (80 %), 140 (48 %), 135 (92 %), 125 (74 %), 121 (89 %), 107 (91 %), 105 (80 %), 97 (48 %); HRMS (EI) Found: 276.1723 ($C_{16}H_{28}Si_2$ (M^+) requires 276.1724).

(±)-(4R*,5S*) 4-Methyl-hexane-1,5-diol 357¹⁰

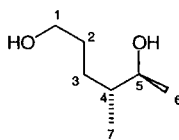

◦ **Stage 1**

To a solution of silacycle **356** (39 mg, 0.123 mmol) in dry chloroform (2 ml) was added trifluoroborane-acetic acid complex (0.33 ml, 2.45 mmol).¹⁰ The mixture was then heated to reflux and stirred for 17 h. The solution was then allowed to cool to RT and saturated sodium hydrogen carbonate solution (5 ml) and DCM (5 ml) was added. The aqueous layer was separated and extracted with DCM (3 x 5 ml). The combined organic layers were then dried over $MgSO_4$, filtered, concentrated and dried *in vacuo* to give a pale orange oil which was used immediately in stage 2.

◦ **Stage 2**

To the pale orange oil was added potassium hydrogen carbonate (14 mg, 9.43 mmol). The mixture was dissolved in THF/MeOH solution (1:1, 2 ml) and hydrogen peroxide (35 % w/w solution in water, 0.15 ml, 1.48 mmol) was added. The mixture was heated to reflux and stirred for 1.3 h.¹⁰ The mixture was then allowed to cool to RT and saturated sodium thiosulfate solution (5 ml) was added together with ethyl acetate (5 ml). The aqueous layer was separated and extracted with ethyl acetate (3 x 5 ml). The combined organic extracts were dried over $MgSO_4$, filtered, concentrated and dried *in vacuo*. Flash column chromatography (pet. ether/ethyl acetate [1:4]) gave the title compound as a mixture of diastereoisomers as a colourless oil (9 mg, 56 %); R_f (pet. ether/ethyl acetate [1:4]) 0.26; ν_{max} (thin film) 3354 (broad, O-H), 2964, 2927, 2876, 1456, 1379, 1269, 1098, 1056 cm^{-1} ; NMR data for major isomer **357**: δ_H (400 MHz; $CDCl_3$) 3.65 (3 H, m, 1-*H* and 5-*H*), 1.72-1.60 (3 H, m, 2-*HH* and OH's), 1.58-1.46 (3 H, m, 2-*HH*, 3-*HH* and 4-*H*), 1.18 (1 H, m, 3-*HH*), 1.15 (3 H, d, J 6.5, 6-*H*₃), 0.89 (3 H, d, J 7.0, 7-*H*₃); δ_C (101 MHz; $CDCl_3$) 71.71 (5-*C*), 63.12 (1-*C*), 39.85 (4-*C*), 30.15 (2-*C*), 28.53 (3-*C*), 19.74 (6-*C*), 14.79 (7-*C*); m/z (ES) 155 ($M+Na^+$, 100 %).

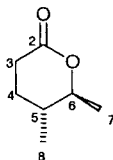
(±)-(6R*,5S*) 6-Methyl-5-methyl-tetrahydro-pyran-2-one 358

To a solution of diol **357** (9 mg, 0.068 mmol) in dry DCM (1 ml) was added powdered molecular sieves (4 Å, approx. 0.1 g), NMO (31 mg, 0.267 mmol) and TPAP (0.9 mg, 0.0025 mmol).¹⁶⁸⁻¹⁷⁰ The mixture was stirred at RT for 24 h. It was then concentrated under reduced pressure. [High vacuum was not used as the product is volatile]. Flash column chromatography, gradient elution (pet. ether/ether [2:1], [1:1]) gave the title compound along with its diastereoisomer as a clear oil (5 mg, 56 %) in a ratio of 89 : 11 % (by GC and NMR); R_f (pet. ether/ether [1:1]) 0.22; ν_{\max} (thin film) 2959, 2924, 2886, 2852, 1734 (C=O), 1458, 1383, 1351, 1251, 1225, 1095, 1046 cm^{-1} ; NMR data for the major isomer **358**: δ_H (500 MHz; CDCl_3) 4.05 (1 H, dq, J 9.5, 6.5, 6-*H*), 2.63 (1 H, ddd, J 17.5, 7.0, 4.0 3a-*H*), 2.48 (1 H, ddd, J 17.5, 10.0, 7.5, 3b-*H*), 1.90 (1 H, m, 4a-*H*), 1.65-1.51 (2 H, m, 5-*H* and 4b-*H*), 1.36 (3 H, d, J 6.0, 7- H_3), 1.00 (3 H, d, J 6.5, 8- H_3); δ_C (126 MHz; CDCl_3) 171.71 (C=O), 82.48 (6-*C*), 34.61 (5-*C*), 29.65 (3-*C*), 27.85 (4-*C*), 19.97 (7-*C*), 17.34 (8-*C*); m/z (EI) 128 (M^+ , 5 %), 113 (M^+ -Me, 4 %), 99 (1 %), 85 (10 %), 84 (M^+ - ^iPr , 80 %), 69 (8 %), 56 (100 %); all data from which agrees with that given in the literature.¹⁹¹

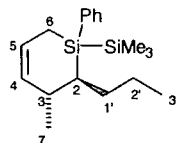
1-phenyl-1-trimethylsilyl-2-*n*-butyl-3-methylsilacyclohex-4-ene 359

n-Butyllithium (1.6 M solution in hexane, 2.28 ml, 3.65 mmol) was added to a stirred solution of silyl alcohol **218** (1.16 g, 3.58 mmol) and 1,3-pentadiene (mixture of *cis* + *trans* isomers, 2.14 ml, 21.48 mmol) in dry ether (52 ml) at RT to give a yellow solution. The mixture was stirred for 3 h then cooled to $-45\text{ }^\circ\text{C}$. An anhydrous solution of LiBr in ether (0.31 M, 0.58 ml, 0.18 mmol) was added and the mixture was warmed to $-30\text{ }^\circ\text{C}$ and stirred for 21 h. Saturated ammonium chloride solution (50 ml) was added and the mixture allowed to reach RT. The aqueous layer was separated and extracted with ether (3 x 50 ml). The combined organic layers were dried over MgSO_4 , filtered, concentrated and dried *in vacuo*. Flash column chromatography (pet. ether) gave the title compound as a colourless oil (0.13 g, 12 %); R_f (pet. ether) 0.65 as a mixture of diastereoisomers in a ratio of 81 : 12 : 7 % (ratio of product peak integrals by GC); ν_{\max} (thin film) 3066, 2997, 2953, 2925, 2869, 1460, 1427, 1396, 1243, 1101, 852, 833, 734, 698 cm^{-1} ; NMR data for major isomer **359**: δ_H

(400 MHz; CDCl₃) 7.51-7.49 (2 H, m, Ar-*H*), 7.34-7.31 (3 H, m, Ar-*H*), 5.83 (1 H, ddt, J 10.5, 5.0, 2.0, 5-*H*), 5.51 (1 H, ddt, J 10.5, 4.0, 2.0, 4-*H*), 2.25 (1 H, m, 3-*H*), 1.65 (1 H, ddt, J 17.5, 5.0, 2.0, 6-*HH*), 1.64-1.50 (3 H, m, 6-*HH* and 1'-*H*₂), 1.48-1.27 (3 H, m, 2-*H* and 2'-*H*₂), 1.03 (3 H, d, J 7.0, 7-*H*₃), 0.86 (3 H, t, J 7.5, 3'-*H*₃), 0.17 (9 H, s, Si(CH₃)₃); δ_C (126 MHz; CDCl₃) 136.95 (4-*C*), 134.50 (*ipso*-Ar), 134.43 (*meta*-Ar), 128.36 (*para*-Ar), 127.70 (*ortho*-Ar), 124.07 (5-*C*), 35.93 (3-*C*), 34.19 (6-*C*), 30.04 (1'-*C*), 23.44 (2'-*C*), 22.26 (7-*C*), 14.49 (3'-*C*), 9.87 (2-*C*), -0.57 (Si(CH₃)₃); *m/z* (GCMS, EI) 302 (M⁺, 18 %), 259 (M⁺-Me, 6 %), 259 (6 %), 229 (M⁺SiMe₃, 80 %), 218 (67 %), 203 (88 %), 201 (58 %), 187 (68 %), 177 (65 %), 175 (54 %), 173 (100 %), 163 (37 %), 161 (58 %), 159 (71 %), 145 (83 %), 135 (98 %), 121 (95 %).

1-phenyl-1-trimethylsilyl-2-*n*-butyl-3-methylsilacyclohexane **360**

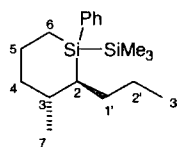

A mixture of silacycle **359** (0.23 g, 0.77 mmol), Pd on carbon (10 % Pd, approx. 10 mg) in dry toluene (5 ml) was repeatedly evacuated and flushed with hydrogen from a balloon. The mixture was then stirred under the hydrogen atmosphere for 23 h.¹⁰ It was then filtered through a celite pad and washed through with ether. The filtrate was concentrated and dried *in vacuo*. Flash column chromatography (pet. ether) gave the title compound as a colourless oil (80 mg, 34 %); R_f (hexane) 0.84 as a mixture of three diastereoisomers in a ratio of 81 : 11 : 8 % (ratio of product peak integrals by GC); ν_{max} (thin film) 3067, 3054, 2953, 2921, 2868, 1457, 1427, 1243, 1100, 851, 833, 732, 698 cm⁻¹; NMR data for major isomer **360**: δ_H (500 MHz; CDCl₃) 7.52-7.50 (2 H, m, *meta* Ar-*H*), 7.32-7.30 (3 H, m, *ortho* and *para* Ar-*H*), 1.97 (1 H, dm, J 13.5, 5-*HH*), 1.71 (1 H, dm, J 13.5, 4-*HH*), 1.60 (2 H, m, 3-*HH* and 1'-*HH*), 1.50 (2 H, m, 5-*HH* and 1'-*HH*), 1.25 (2 H, m, 2'-*H*₂), 1.08 (2 H, m, 4-*HH* and 6-*HH*), 0.97 (3 H, d, J 6.5, 7-*H*₃), 0.86 (1 H, m, 2-*H*), 0.83 (1 H, m, 6-*HH*), 0.80 (3 H, t, J 7.0, 3'-*H*₃), 0.20 (9 H, s, Si(CH₃)₃); δ_C (126 MHz; CDCl₃) 139.64 (*ipso*-Ar), 134.37 (*meta*-Ar), 128.20 (*para*-Ar), 127.64 (*ortho*-Ar), 38.30 (4-*C*), 37.41 (3-*C*), 34.14 (1'-*H*), 32.13 (2-*H*), 23.98 (2'-*H*), 23.67 (5-*H*), 22.66 (7-*H*), 14.63 (3'-*H*), 12.50 (6-*C*), 0.17 (Si(CH₃)₃); *m/z* (EI) 304 (M⁺, 40 %), 289 (M⁺-Me, 6 %), 231 (M⁺-SiMe₃, 99 %), 203 (24 %), 189 (23 %), 175 (71 %), 163 (51 %), 161 (80 %), 153 (42 %), 147 (73 %), 135 (92 %); HRMS (EI) Found: 304.2045 (C₁₈H₃₂Si₂ (M⁺) requires 304.2043).

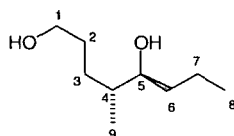
(±)-(4R*,5S*) 4-Methyl-octane-1,5-diol 361

- **Stage 1**

To a solution of silacycle **360** (84 mg, 0.276 mmol) in dry chloroform (6 ml) was added trifluoroborane-acetic acid complex (0.75 ml, 5.53 mmol).¹⁰ The mixture was then heated to reflux and stirred for 17 h. The solution was then allowed to cool to RT and saturated sodium hydrogen carbonate solution (6 ml) was added. The aqueous layer was separated and extracted with DCM (3 x 6 ml). The combined organic layers were then dried over MgSO₄, filtered, concentrated and dried *in vacuo* to give a pale orange oil which was used immediately in stage 2.

- **Stage 2**

To the pale orange oil was added potassium hydrogen carbonate (30 mg, 0.304 mmol). The mixture was dissolved in THF/MeOH solution (1:1, 6 ml) and hydrogen peroxide (35 % w/w solution in water, 0.33 ml, 3.31 mmol) was added. The mixture was heated to reflux and stirred for 19 h.¹⁰ The mixture was then allowed to cool to RT and saturated sodium thiosulfate solution (6 ml) was added together with ethyl acetate (6 ml). The aqueous layer was separated and extracted with ethyl acetate (3 x 6 ml). The combined organic extracts were dried over MgSO₄, filtered, concentrated and dried *in vacuo*. Flash column chromatography (pet. ether/ethyl acetate [1:1]) gave the title compound as a white solid (7 mg, 16 %) consisting of a mixture of two diastereoisomers in a ratio of 74 : 26 % by NMR; R_f (pet. ether/ethyl acetate [1:1]) 0.15; ν_{max} (thin film) 3355 (broad, O-H), 2956, 2930, 2874, 1460, 1372, 1108, 1059, 976 cm⁻¹; NMR data for major isomer **361**: δ_H (500 MHz; CDCl₃) 3.65 (2 H, t, J 7.0, 1-H₂), 3.45 (1 H, m, 5-H), 1.68 (1 H, m, 2-HH), 1.56-1.48 (3 H, m, 2-HH, 3-HH and 4-H), 1.44-1.32 (4 H, m, 6-H₂ and 7-H₂), 1.19 (1 H, m, 3-HH), 0.94 (3 H, t, J 7.0, 8-H₃), 0.91 (3 H, d, J 7.0, 9-H₃); δ_C (126 MHz; CDCl₃) 75.66 (5-C), 63.22 (1-C), 38.60 (4-C), 35.74 (6-C), 30.31 (2-C), 27.95 (3-C), 19.18 (7-C), 15.41 (9-C), 14.15 (8-C); *m/z* (CI) 178 (M+NH₄⁺, 12 %), 161 (M+H⁺, 3 %), 52 (100 %).

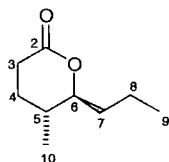
(±)-(6S*,5R*) 6-Propyl-5-methyl-tetrahydro-pyran-2-one 362

To a solution of diol **361** (7 mg, 0.044 mmol) in dry DCM (1.5 ml) was added powdered molecular sieves (4 Å, approx. 0.01 g), NMO (20 mg, 0.172 mmol) and TPAP (0.6 mg, 0.0016 mmol).¹⁶⁸⁻¹⁷⁰ The mixture was stirred at RT for 24 h. It was then concentrated under reduced pressure. [High vacuum was not used as the product is volatile]. Flash column chromatography, gradient elution (pet. ether/ether [2:1], [1:1]) gave the title compounds as a clear oil (2 mg, 29 %); R_f (pet. ether/ether [1:1]) 0.29 in a ratio of 72 : 28 % (ratio of product peak integrals by GC); ν_{\max} (thin film) 2960, 2931, 2874, 1736 (C=O), 1463, 1383, 1251, 1212, 1116, 1097, 1068, 1033, 1000 cm^{-1} ; NMR data for major isomer **362**: δ_H (500 MHz; CDCl_3) 3.94 (1 H, td, J 8.0, 3.0, 6-*H*), 2.61 (1 H, ddd, J 18.0, 7.0, 4.5 3a-*H*), 2.46 (1 H, ddd, J 18.0, 10.0, 7.0, 3b-*H*), 1.90 (1 H, ddt, J 13.5, 7.0, 5.0, 4a-*H*), 1.73-1.65 (2 H, m, 5-*H* and 7-*HH*), 1.60-1.51 (3 H, m, 7-*HH*, 8-*HH* and 4b-*H*), 1.43 (1 H, m, 8-*HH*), 1.00 (3 H, d, J 6.5, 10-*H*₃), 0.93 (3 H, t, J 7.5, 9-*H*₃); δ_C (126 MHz; CDCl_3) 171.92 (C=O), 85.67 (6-*C*), 35.54 (5-*C*), 32.23 (7-*C*), 29.52 (3-*C*), 27.78 (4-*C*), 17.72 (8-*C*), 17.44, (10-*C*), 13.90 (9-*C*); m/z (EI) 156 (M^+ , 1 %), 138 (1 %), 128 (6 %), 113 ($M^+ - n\text{Pr}$, 86 %), 85 (49 %), 84 (78 %).

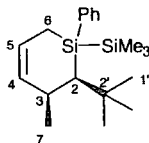
1-phenyl-1-trimethylsilyl-2-(*t*-butyl)-3-methylsilacyclohex-4-ene 363

n-Butyllithium (1.6 M solution in hexane, 5.22 ml, 8.36 mmol) was added to a stirred solution of silyl alcohol **232** (2.80 g, 8.27 mmol) and 1,3-pentadiene (mixture of *cis* + *trans* isomers, 4.5 ml, 44.8 mmol) in dry ether (107 ml) at RT to give a yellow solution. The mixture was stirred for 2 h then cooled to $-45\text{ }^\circ\text{C}$. An anhydrous solution of LiBr in ether (0.31 M, 1.19 ml, 0.37 mmol) was added and the mixture was warmed to $-30\text{ }^\circ\text{C}$ and stirred for 22 h. Saturated ammonium chloride solution (100 ml) was added and the mixture allowed to reach RT. The aqueous layer was separated and extracted with ether (3 x 100 ml). The combined organic layers were dried over MgSO_4 , filtered, concentrated and dried *in vacuo*. Flash column chromatography (pet. ether) gave the title compound as a colourless oil (0.81 g, 35 %); R_f (pet. ether) 0.65 together with small amounts of diastereoisomers in a ratio of 85 : 5 : 5 : 5 % (ratio of product peak integrals by GC); ν_{\max} (thin film) 3067, 3049, 2995, 2954, 2897, 2867, 1465, 1427, 1393, 1364, 1245, 1099, 853, 835, 737, 711, 699 cm^{-1} ;

NMR data for major isomer **363**: δ_{H} (500 MHz; CDCl_3) 7.53-7.52 (2 H, m, *Ar-H*), 7.33-7.29 (3 H, m, *Ar-H*), 5.85 (1 H, m, 5-*H*), 5.74 (1 H, dd, J 10.0, 7.0, 4-*H*), 2.53 (1 H, pent, J 7.0, 3-*H*), 1.75 (1 H, dd, J 16.5, 2.0, 6-*HH*), 1.50 (1 H, dd, J 16.5, 6.0, 6-*HH*), 1.24 (1 H, s, 2-*H*), 1.02 (9 H, s, $\text{C}(\text{CH}_3)_3$), 0.89 (3 H, d, J 7.0, 7-*H}_3*), 0.14 (9 H, s, $\text{Si}(\text{CH}_3)_3$); δ_{C} (126 MHz; CDCl_3) 140.40 (*ipso-Ar*), 136.88 (4-*C*), 134.49 (*meta-Ar*), 127.92 (*para-Ar*), 127.60 (*ortho-Ar*), 123.83 (5-*C*), 45.77 (2-*C*), 34.50 ($\text{C}(\text{CH}_3)_3$), 32.65 (3-*C*), 30.65 ($\text{C}(\text{CH}_3)_3$), 24.55 (7-*C*), 9.35 (6-*C*), -0.41 ($\text{Si}(\text{CH}_3)_3$); m/z (GCMS, EI) 316 (M^+ , 20 %), 301 (M^+ -Me, 7 %), 259 (21 %), 247 (26 %), 243 (M^+ -SiMe₃, 83 %), 218 (57 %), 203 (79 %), 175 (100 %).

1-phenyl-1-trimethylsilyl-2-methyl-3-methylsilacyclohexane **364**

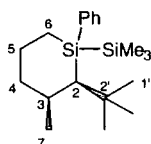

A mixture of silacycle **363** (0.80 g, 2.53 mmol) and $\text{PtO}_2 \cdot \text{H}_2\text{O}$ (18 mg, 0.073 mmol) in ethyl acetate (24 ml) was repeatedly evacuated and flushed with hydrogen from a balloon. The mixture was then stirred under the hydrogen atmosphere for 1 h.^{175, 177} It was then filtered through a celite pad and washed through with ether. The filtrate was concentrated and dried *in vacuo*. Flash column chromatography (pet. ether) gave the title compound as a colourless oil (0.70 g, 87 %); R_f (pet. ether) 0.84 as a mixture of 3 detectable diastereoisomers (it is believed a fourth has an identical GC retention time to the major product) in a ratio of 90 : 6 : 4 % (ratio of product peak integrals by GC); ν_{max} (thin film) 3066, 3049, 2954, 2911, 2862, 1469, 1427, 1391, 133, 1323, 1244, 1168, 1154, 1097, 835, 744, 733, 699 cm^{-1} ; NMR data for major isomer **364**: δ_{H} (500 MHz; CDCl_3) 7.51-7.49 (2 H, m, *meta-Ar-H*), 7.33-7.27 (3 H, m, *ortho* and *para-Ar-H*), 2.21 (1 H, m, 3-*H*), 1.81 (1 H, m, 5-*HH*), 1.70-1.62 (2 H, m, 5-*HH* and 4-*HH*), 1.39 (1 H, m, 4-*HH*), 1.24 (1 H, dt, J 15.0, 6.0, 6-*HH*), 1.08-1.07 (10 H, m, $\text{C}(\text{CH}_3)_3$ and 2-*H*), 0.82 (1 H, m, 6-*HH*), 0.75 (3 H, d, J 7.5, 7-*H}_3*), 0.05 (9 H, s, $\text{Si}(\text{CH}_3)_3$); δ_{C} (126 MHz; CDCl_3) 141.12 (*ipso-Ar*), 134.13 (*meta-Ar*), 127.52 (*ortho-Ar*), 127.49 (*para-Ar*), 44.68 (2-*C*), 34.28 ($\text{C}(\text{CH}_3)_3$), 33.78 (4-*C*), 31.77 (3-*C*), 31.51 ($\text{C}(\text{CH}_3)_3$), 24.30 (7-*C*), 17.94 (5-*C*), 8.73 (6-*C*), -1.06 ($\text{Si}(\text{CH}_3)_3$); m/z (EI) 318 (M^+ , 32 %), 303 (M^+ -Me, 6 %), 245 (M^+ -SiMe₃, 96 %), 217 (12 %), 189 (26 %), 187 (70 %), 175 (72 %), 167 (47 %), 161 (74 %), 147 (58 %), 145 (49 %), 135 (91 %), 121 (100 %).

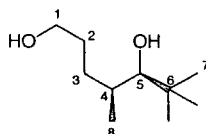
(±)-(4S*,5S*) 4,6,6-Trimethyl-hexane-1,5-diol 365

- **Stage 1**

To a solution of silacycle **364** (0.13 g, 0.39 mmol) in dry chloroform (8 ml) was added trifluoroborane-acetic acid complex (1.1 ml, 7.9 mmol).¹⁰ The mixture was then heated to reflux and stirred for 18 h. The solution was then allowed to cool to RT and saturated sodium hydrogen carbonate solution (10 ml) was added. The aqueous layer was separated and extracted with DCM (3 x 10 ml). The combined organic layers were then dried over MgSO₄, filtered, concentrated and dried *in vacuo* to give a pale orange oil which was used immediately in stage 2.

- **Stage 2**

To the pale orange oil was added potassium hydrogen carbonate (43 mg, 0.43 mmol). The mixture was dissolved in THF/MeOH solution (1:1, 8 ml) and hydrogen peroxide (35 % w/w solution in water, 0.47 ml, 4.72 mmol) was added. The mixture was heated to reflux and stirred for 3 h.¹⁰ The mixture was then allowed to cool to RT and saturated sodium thiosulfate solution (8 ml) was added together with ethyl acetate (8 ml). The aqueous layer was separated and extracted with ethyl acetate (3 x 8 ml). The combined organic extracts were dried over MgSO₄, filtered, concentrated and dried *in vacuo*. Flash column chromatography (pet. ether/ethyl acetate [1:1]) gave the title compound as a mixture of diastereoisomers as a colourless oil (14 mg, 21 %); R_f (pet. ether/ethyl acetate [1:4]) 0.32; ν_{max} (thin film) 3388 (broad, O-H), 2956, 2874, 1482, 1468, 1104, 1064 cm⁻¹; NMR data for major diastereoisomer **365**: δ_H (500 MHz; CDCl₃) 3.62 (2 H, t, J 6.0, 1-H₂), 3.11 (1 H, d, J 3.0, 5-H), 1.73-1.65 (2 H, m, 4-H and 2-HH), 1.62 (1 H, m, 3-HH), 1.48 (1 H, m, 2-HH), 1.13 (1 H, m, 3-HH), 1.00 (3 H, d, J 7.0, 8-H₃), 0.92 (9 H, s, C(CH₃)₃); δ_C (126 MHz; CDCl₃) 84.05 (5-C), 63.20 (1-C), 35.89 (6-C), 33.91 (4-C), 30.82 (2-C), 27.12 (3-C), 26.65 (C(CH₃)₃), 20.45 (8-C); *m/z* (ES⁺) 197 (M+Na⁺, 100 %); HRMS (ES⁺) Found: 197.1503 (C₁₀H₂₂O₂Na (M+Na⁺) requires 197.1517).

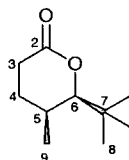
(±)-(6*S,5*S**) 6-*tert*-butyl-5-methyl-tetrahydro-pyran-2-one 366**

To a solution of diol **365** (34 mg, 0.029 mmol) in dry DCM (4 ml) was added powdered molecular sieves (4 Å, approx. 0.1 g), NMO (90 mg, 0.764 mmol) and TPAP (2.5 mg, 0.0072 mmol).¹⁶⁸⁻¹⁷⁰ The mixture was stirred at RT for 20 h. It was then concentrated under reduced pressure. [High vacuum was not used as the product is volatile]. Flash column chromatography (pet. ether/ether [3:1]) gave the title compound as a clear oil (12 mg, 36 %); R_f (pet. ether/ether [1:1]) 0.43 as a mixture of diastereoisomers in a ratio of 87 : 13 % (ratio of product peak integrals by GC); ν_{\max} (thin film) 2959, 2930, 2873, 1742 (C=O), 1482, 1460, 1380, 1368, 1328, 1244, 1197, 1081, 1061, 1003 cm^{-1} ; NMR data for major isomer **366**: δ_H (500 MHz; CDCl_3) 3.71 (1 H, d, J 7.0, 6-*H*), 2.46 (1 H, ddd, J 17.5, 8.5, 5.0, 3ax-*H*), 2.32 (1 H, ddd, J 17.5, 9.0, 5.0, 3eq-*H*), 2.01 (1 H, m, 5-*H*), 1.85 (1 H, m, 4ax-*H*), 1.57 (1 H, m, 4eq-*H*), 1.11 (3 H, d, J 7.0, 9- H_3), 0.99 (9 H, s, $\text{C}(\text{CH}_3)_3$); δ_C (126 MHz; CDCl_3) 173.04 (C=O), 92.54 (6-*C*), 36.17 (3-*C*), 28.69 (4-*C*), 27.86 (5-*C*), 27.75 ($\text{C}(\text{CH}_3)_3$), 25.98 ($\text{C}(\text{CH}_3)_3$), 21.41 (9-*C*); m/z (EI) 170 (M^+ , 1 %), 155 (M^+ -Me, 1 %), 142 (1 %), 127 (4 %), 114 (44 %), 113 (M^+ -^tBu, 100 %), 99 (12 %), 85 (62 %); HRMS (EI) Found: 170.1302 ($\text{C}_{10}\text{H}_{18}\text{O}_2$ (M^+) requires 170.1301); all data from which agrees with that given in the literature.¹⁹²

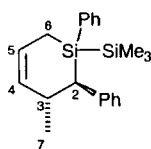
1-phenyl-1-trimethylsilyl-2-phenyl-3-methylsilacyclohex-4-ene 370

n-Butyllithium (1.6 M solution in hexane, 4.21 ml, 6.74 mmol) was added to a stirred solution of silyl alcohol **236** (2.34 g, 6.61 mmol) and 1,3-pentadiene (mixture of *cis* + *trans* isomers, 3.95 ml, 39.66 mmol) in dry ether (96 ml) at RT. The mixture was stirred for 3 h then cooled to -45 °C. An anhydrous solution of LiBr in ether (0.31 M, 1.06 ml, 0.33 mmol) was added and the mixture was warmed to -30 °C and stirred for 22 h. Saturated ammonium chloride solution (90 ml) was added and the mixture allowed to reach RT. The aqueous layer was separated and extracted with ether (3 x 90 ml). The combined organic layers were dried over MgSO_4 , filtered, concentrated and dried *in vacuo*. Flash column chromatography (pet. ether) gave the title compound as a colourless oil (1.00 g, 45 %); R_f (pet. ether) 0.40 as a mixture of three diastereoisomers in a ratio of 74 : 20 : 6 % (ratio of

product peak integrals by GC); ν_{\max} (thin film) 3065, 3019, 2998, 2951, 2920, 2890, 2868, 1597, 1490, 1449, 1427, 1243, 1102, 857, 834, 783, 735, 699 cm^{-1} ; NMR data for major isomer **370**: δ_{H} (500 MHz; CDCl_3) 7.33-7.27 (5 H, m, Ar-*H*), 7.17-7.12 (3 H, m, Ar-*H*), 6.02 (1 H, dtd, *J* 10.5, 5.5, 2.5, 5-*H*), 5.68 (1 H, ddt, *J* 10.5, 3.0, 2.0, 4-*H*), 2.88 (1 H, m, 3-*H*), 2.46 (1 H, d, *J* 9.5, 2-*H*), 1.89 (1 H, ddt, *J* 17.0, 5.0, 2.0, 6-*HH*), 1.69 (1 H, ddt, *J* 17.0, 5.5, 2.0, 6-*HH*), 1.01 (3 H, d, *J* 7.0, 7-*H*₃), -0.02 (9 H, s, $\text{Si}(\text{CH}_3)_3$); δ_{C} (126 MHz; CDCl_3) 144.53 (*ipso*-Ar), 136.62 (4-*C*), 134.45 (Ar), 134.00 (Ar), 128.52 (Ar), 128.34 (Ar), 128.09 (Ar), 127.59 (Ar), 124.62 (Ar), 124.58 (5-*C*), 40.90 (2-*C*), 36.22 (3-*C*), 22.02 (7-*C*), 9.57 (6-*C*), -1.29 ($\text{Si}(\text{CH}_3)_3$); *m/z* (GCMS, EI) 336 (M^+ , 36 %), 321 (M^+ -Me, 10 %), 268 (93 %), 253 (100 %), 235 (42 %), 221 (57 %), 207 (49 %), 203 (76 %), 197 (44 %), 185 (67 %), 183 (78 %), 177 (61 %), 175 (73 %), 159 (54 %), 145 (70 %), 135 (91 %); HRMS (EI) Found: 336.1726 ($\text{C}_{21}\text{H}_{28}\text{Si}_2$ (M^+) requires 336.1730).

1-phenyl-1-trimethylsilyl-2-phenyl-3-methylsilacyclohexane **371**

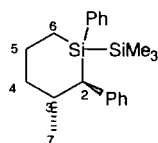

A mixture of silacycle **370** (0.87 g, 2.59 mmol) and Pd on carbon (10 % Pd, approx. 27 mg) in dry toluene (17 ml) was repeatedly evacuated and flushed with hydrogen from a balloon.¹⁰ The mixture was then stirred under the hydrogen atmosphere for 22 h. It was then filtered through a celite pad and washed through with ether. The filtrate was concentrated and dried *in vacuo*. Flash column chromatography (pet. ether) gave the title compound as a colourless oil (0.71 g, 81 %); *R_f* (hexane) 0.36 as a mixture of 2 detectable diastereoisomers (it is believed the third has an identical GC retention time to the major product and indeed that peak has a shoulder) in a ratio of 93 : 7 % (ratio of product peak integrals by GC); ν_{\max} (thin film) 3067, 3028, 2948, 2922, 2908, 2868, 2856, 1600, 1487, 1451, 1427, 1243, 1101, 855, 832, 763, 733, 699 cm^{-1} ; NMR data for major isomer **371**: δ_{H} (400 MHz; CDCl_3) 7.32-7.11 (8 H, m, Ar-*H*), 7.01 (2 H, d, *J* 7.5, Ar-*H*), 2.24 (1 H, m, 3-*H*), 2.21 (1 H, m, 5eq-*H*), 2.10 (1 H, d, *J* 12.5, 2-*H*), 1.94 (1 H, dm, *J* 14.0, 4eq-*H*), 1.70 (1 H, qt, *J* 14.0, 3.0, 5ax-*H*), 1.33 (1 H, dm, *J* 14.0, 6eq-*H*), 1.21 (1 H, qd, *J* 14.0, 2.5, 4ax-*H*), 1.08 (1 H, td, *J* 14.0, 5.0, 6ax-*H*), 0.86 (3 H, d, *J* 6.5, 7-*H*₃), 0.08 (9 H, s, $\text{Si}(\text{CH}_3)_3$); δ_{C} (101 MHz; CDCl_3) 144.01 (Ar), 137.30 (Ar), 134.79 (Ar), 128.43 (Ar), 128.46 (Ar), 128.07 (Ar), 127.37 (Ar), 124.43 (Ar), 44.30 (2-*C*), 38.88 (4-*C*), 36.69 (3-*C*), 24.47 (5-*C*), 22.71 (7-*C*), 11.76 (6-*C*), -0.32 ($\text{Si}(\text{CH}_3)_3$); *m/z* (EI) 338 (M^+ , 68 %), 323 (M^+ -Me, 33 %), 268 (70 %), 265 (M^+ -SiMe₃, 81 %), 253 (70 %), 237 (67 %), 233 (66 %), 197 (84 %), 189 (70 %), 188 (77 %), 183 (93 %), 159 (72 %), 145 (80 %), 135 (100 %).

1-Fluoro-1-trimethylsilyl-2-phenyl-3-methylsilacyclohexane 372

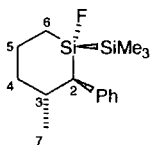

To a solution of silacycle **371** (0.55 mg, 1.63 mmol) in dry chloroform (32 ml) was added trifluoroborane-acetic acid complex (4.4 ml, 32.54 mmol).¹⁰ The mixture was then heated to reflux and stirred for 17 h. The solution was then allowed to cool to RT and saturated sodium hydrogen carbonate solution (32 ml) and DCM (32 ml) was added. The aqueous layer was separated and extracted with DCM (3 x 32 ml). The combined organic layers were then dried over MgSO₄, filtered, concentrated and dried *in vacuo*. Flash column chromatography (pet. ether) gave the pure title compound as a colourless oil (0.21 g, 45 %); R_f (pet. ether) 0.36; ν_{max} (thin film) 3062, 3023, 2949, 2921, 2859, 1596, 1490, 1451, 1247, 1169, 1086, 1072, 1039, 936, 861, 839, 801, 753, 733, 699, 670, 537 cm⁻¹; δ_H (500 MHz; CDCl₃) 7.26 (2 H, m, Ar-*H*), 7.15 (3 H, m, Ar-*H*), 2.22 (1 H, md, J 3.0, 3-*H*), 2.06 (1 H, dm, J 14.0, 5eq-*H*), 1.89 (1 H, dm, J 14.0, 4eq-*H*), 1.80 (1 H, qt, J 14.0, 2.5, 5ax-*H*), 1.63 (1 H, dd, J 17.5, 12.0, 2-*H*), 1.20 (1 H, dm, J 14.0, 6eq-*H*), 1.15 (1 H, qm, J 14.0, 4ax-*H*), 0.79 (3 H, d, J 6.5, 7-*H*₃), 0.50 (1 H, dtd, J 21.0, 14.0, 5.5, 6ax-*H*), -0.12 (9 H, s, Si(CH₃)₃); δ_C (126 MHz; CDCl₃) 142.58 (*ipso*-Ar), 128.54 (Ar), 128.31 (Ar), 124.91 (Ar), 45.35 (2-C), 38.36 (4-C), 35.80 (3-C), 22.67 (7-C), 22.18 (5-C), 14.46 (6-C), -2.74 (Si(CH₃)₃); δ_F (282 MHz; CDCl₃) -194.12 (m); *m/z* (GCMS, EI) 280 (M⁺, 14 %), 265 (M⁺-Me, 5 %), 188 (M⁺-SiMe₃-F, 86 %), 173 (27 %), 160 (54 %), 146 (66 %), 145 (65 %), 110 (100 %).

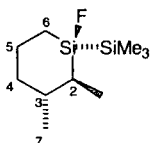

Further elution gave pure 1-Fluoro-1-trimethylsilyl-2-phenyl-3-methylsilacyclohexane **375** as a clear oil (0.08 g, 18 %); R_f (pet. ether) 0.26; ν_{max} (thin film) 3084, 3062, 3025, 2950, 2923, 2868, 2860, 1602, 1497, 1456, 1404, 1374, 1245, 1034, 863, 835, 809, 766, 741, 699, 620, 508 cm⁻¹; δ_H (500 MHz; CDCl₃) 7.44 (2 H, m, Ar-*H*), 7.29 (3 H, m, Ar-*H*), 2.32 (2 H, m, 2-*H* and 3-*H*), 2.26 (1 H, dm, J 14.0, 5eq-*H*), 2.05 (1 H, dm, J 14.0, 4eq-*H*), 1.57 (1 H, qt, J 14.0, 2.5, 5ax-*H*), 1.44 (1 H, dm, J 14.0, 6eq-*H*), 1.35 (1 H, qd, J 14.0, 2.5, 4ax-*H*), 1.11 (3 H, d, J 6.0, 7-*H*₂), 1.00 (1 H, tdd, J 14.0, 5.0, 4.0), 0.09 (9 H, s, Si(CH₃)₃); δ_C (126 MHz; CDCl₃) 142.18 (*ipso*-Ar), 128.44 (Ar), 127.51 (Ar), 124.61 (Ar), 45.75 (d, J 6.0, 2-C), 37.91 (4-C), 34.90 (d, J 3.5, 3-C), 22.56 (d, J 4.5, 5-C), 21.98 (7-C), 14.67 (d, J 8.0, 6-C), -2.06 (Si(CH₃)₃); δ_F (282 MHz; CDCl₃) -182.71 (m); *m/z* (GCMS, EI) 280 (M⁺, 21 %), 265 (M⁺-

Me, 13 %), 188 (M^+ -SiMe₃-F, 85 %), 173 (48 %), 160 (68 %), 146 (70 %), 145 (79 %), 110 (100 %).

(±)-(4R*5S*) 4-Methyl-5-phenylpentane-1,5-diol 373

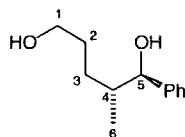

To fluorosilane **372** (0.144 g, 0.514 mmol) was added potassium hydrogen carbonate (57 mg, 0.566 mmol). The mixture was dissolved in THF/MeOH solution (1:1, 10 ml) and hydrogen peroxide (35 % w/w solution in water, 0.62 ml, 6.17 mmol) was added. The mixture was heated to reflux and stirred for 35 min.¹⁰ The mixture was then allowed to cool to RT and saturated sodium thiosulfate solution (10 ml) was added together with ethyl acetate (10 ml). The aqueous layer was separated and extracted with ethyl acetate (3 x 10 ml). The combined organic extracts were dried over MgSO₄, filtered, concentrated and dried *in vacuo*. Flash column chromatography (pet. ether/ethyl acetate [1:1]) gave the pure title compound as a waxy solid (29 mg, 29 %); R_f (pet. ether/ethyl acetate [1:1]) 0.22; ν_{\max} (thin film) 3255 (broad, O-H), 1493, 1463, 1454, 1385, 1310, 1261, 1134, 1108, 1076, 1051, 1009, 928, 915, 761, 703, 555 cm⁻¹; δ_H (500 MHz; CDCl₃) 7.30 (5 H, m, Ar-*H*), 4.39 (1 H, d, *J* 7.5, 5-*H*), 3.63 (2 H, t, *J* 6.5, 1-*H*), 1.84 (1 H, m, 4-*H*), 1.79-1.66 (2 H, m, 2-*HH* and 3-*HH*), 1.51 (1 H, m, 2-*HH*), 1.24 (1 H, m, 3-*HH*), 0.74 (3 H, d, *J* 7.5, 6-*H*); δ_C (126 MHz; CDCl₃) 143.47 (*ipso*-Ar), 128.22 (Ar-*H*), 127.49 (*para*-Ar), 126.67 (Ar-*H*), 79.03 (5-*C*), 62.92 (1-*C*), 39.71 (4-*C*), 28.83 (2-*H*), 28.31 (3-*C*), 15.86 (6-*C*); m/z (CI) 212 (M^+ +NH₄⁺, 44 %), 194 (M^+ , 100 %), 177 (M^+ -OH, 58 %). The identical diol was obtained by similar reaction of fluorosilane **375** (7 mg, 29 %).

(±)-(6S*,5R*) 6-Phenyl-5-methyl-tetrahydro-pyran-2-one 374

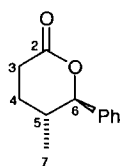

To a solution of diol **373** (7 mg, 0.036 mmol) in dry DCM (1.5 ml) was added powdered molecular sieves (4 Å, approx. 0.01 g), NMO (17 mg, 0.141 mmol) and TPAP (0.5 mg, 0.0013 mmol).¹⁶⁸⁻¹⁷⁰ The mixture was stirred at RT for 24 h. It was then concentrated under reduced pressure. [High vacuum was not used as the product is volatile]. Flash column chromatography, gradient elution (pet. ether/ether [2:1], [1:1]) gave the pure title compound as a clear oil (5 mg, 71 %); R_f (pet. ether/ether [1:1]) 0.21; ν_{\max} (thin film) 3066, 3030, 2966, 2932, 2880, 1731 (C=O), 1455, 1382, 1247, 1221, 1201, 1147, 1084, 1036, 1016,

755, 701 cm^{-1} ; δ_{H} (500 MHz; CDCl_3) 7.39-7.34 (3 H, m, Ar-H), 7.31-7.29 (2 H, m, Ar-H), 4.85 (1 H, d, J 10.5, 6-H), 2.77 (1 H, ddd, J 17.5, 7.0, 4.0 3a-H), 2.65 (1 H, ddd, J 17.5, 10.0, 6.5, 3b-H), 2.06-1.97 (2 H, m, 4a-H and 5-H), 1.71 (1 H, m, 4b-H), 0.85 (3 H, d, J 6.5, 7-H); δ_{C} (126 MHz; CDCl_3) 171.23 (C=O), 138.39 (*ipso*-Ar), 128.65 (Ar), 128.50 (Ar), 127.12 (Ar), 88.34 (6-C), 34.75 (5-C), 29.71 (3-C), 27.81 (4-C), 17.18 (7-C); m/z (EI) 190 (M^+ , 69 %), 162 (28 %), 148 (14 %), 128 (6 %), 120 (16 %), 118 (52 %), 117 (54 %), 105 (93 %), 91 (38 %), 84 (79 %), 77 (Ph^+ , 70 %); all data from which agrees with that given in the literature.¹⁹²

(±)-(4R*,5S*) 4-Methyl-oct-1-en-5-ol **377**

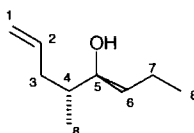

◦ Stage 1

To a solution of silacycle **359** (47 mg, 0.156 mmol) in dry chloroform (4 ml) was added trifluoroborane-acetic acid complex (0.05 ml, 0.35 mmol).¹⁰ The mixture was stirred at RT for 1 h after which time saturated sodium hydrogen carbonate solution (4 ml) was added. The aqueous layer was separated and extracted with DCM (3 x 4 ml). The combined organic extracts were dried over MgSO_4 , filtered, concentrated and dried *in vacuo* to give a clear oil which was used immediately in stage 2.

◦ Stage 2

To the clear oil was added potassium hydrogen carbonate (30 mg, 0.301 mmol) and potassium fluoride (18 mg, 0.310 mmol). The mixture was dissolved in THF/MeOH solution (1:1, 2 ml) and hydrogen peroxide (35 % w/w solution in water, 0.18 ml, 1.86 mmol) was added. The mixture was heated to reflux and stirred for 18 h.¹⁰ The mixture was then allowed to cool to RT and saturated sodium thiosulfate solution (5 ml) was added together with ethyl acetate (5 ml). The aqueous layer was separated and extracted with ethyl acetate (3 x 5 ml). The combined organic extracts were dried over MgSO_4 , filtered and concentrated [High vacuum was not used as it was thought the product may be volatile]. Flash column chromatography (pet. ether/ethyl acetate [19:1]) gave the title compound as a clear oil (4 mg, 18 %); R_f (pet. ether/ethyl acetate [9:1]) 0.29 as a mixture of isomers in a ratio of 84 : 16 % (ratio of product peak integrals by GC); NMR data for major isomer **377**: δ_{H} (500 MHz; CDCl_3) 5.82 (1 H, m, 2-H), 5.05 (1 H, d, J 18.5, 1- H^Z), 5.01 (1 H, d, J 11.0, 1- H^E), 3.46 (1 H, ddd, J 8.5, 5.5, 3.0, 5-H), 2.26 (1 H, ddd, J 14.0, 6.5, 5.0, 3-HH), 1.94 (1 H, dt, J 14.0, 7.5, 3-HH), 1.60 (1 H, m, 4-H), 1.55-1.31 (4 H, m, 6- H_2 and 7- H_2), 0.94 (3 H,

t, J 7.0, 8-*H*₃), 0.90 (3 H, d, J 7.0, 9-*H*₃); δ_C (126 MHz; CDCl₃) 137.57 (2-*C*), 115.90 (1-*C*), 75.43 (5-*C*), 38.66 (4-*C*), 36.81 (3-*C*), 35.86 (6-*C*), 19.09 (7-*C*), 15.41 (8-*C*), 14.14 (9-*C*).

1-Fluoro-2,2,2-trimethyl-1-(2-methyl-1-phenyl-pent-4-enyl)-1-phenyl-disilane **378**¹⁰

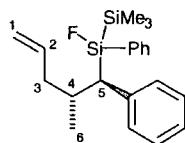

To a solution of silacycle **370** (86 mg, 0.256 mmol) in dry chloroform (7 ml) was added trifluoroborane-acetic acid complex (0.08 ml, 0.57 mmol).¹⁰ The mixture was stirred at RT for 1 h after which time saturated sodium hydrogen carbonate solution (7 ml) was added. The aqueous layer was separated and extracted with DCM (3 x 7 ml). The combined organic extracts were dried over MgSO₄, filtered, concentrated and dried *in vacuo*. Flash column chromatography (pet. ether) gave the title compound as a clear oil (68 mg, 75 %); R_f (pet. ether) 0.21 as a mixture of 3 isomers in a ratio of 82 : 13 : 5 % (ratio of product peak integrals by GC); ν_{\max} (thin film) 3071, 3024, 2957, 2930, 2895, 1638, 1597, 1490, 1450, 1428, 1378, 1246, 1109, 995, 913, 861, 837, 802, 741, 700, 525 cm⁻¹; NMR data for major isomer **378**: δ_H (500 MHz; CDCl₃) 7.52 (2 H, d, J 7.0, Ar-*H*), 7.39 (3 H, m, Ar-*H*), 7.24 (3 H, m, Ar-*H*), 7.08 (2 H, d, J 8.0, Ar-*H*), 5.78 (1 H, ddt, J 17.0, 10.0, 7.0, 2-*H*), 5.04 (2 H, m, 1-*H*₂), 2.51 (1 H, dd, J 8.5, 6.0, 5-*H*), 2.43 (1 H, m, 3-*HH*), 2.15 (1 H, m, 4-*H*), 2.00 (1 H, dt, J 14.0, 7.0, 3-*HH*), 0.81 (3 H, d, J 6.5, 6-*H*₃), -0.02 (9 H, s, Si(CH₃)₃); δ_C (101 MHz; CDCl₃) 133.62 (Ar), 130.23 (Ar), 129.64 (Ar), 128.34 (Ar), 128.28 (Ar), 127.97 (Ar), , 127.83 (Ar), 125.58 (2-*C*), 116.28 (1-*C*), 43.95 (d, J 11.0, 5-*C*), 40.90 (3-*C*), 34.81 (4-*C*), 19.05 (6-*C*), -2.28 (Si(CH₃)₃); δ_F (282 MHz; CDCl₃) -180.28 (m); *m/z* (EI) 356 (M⁺, 3 %), 341 (M⁺-Me, 2 %), 283 (M⁺-SiMe₃, 56 %), 264 (M⁺-SiMe₃-F, 42 %), 223 (19 %), 205 (39 %), 197 (97 %), 165 (67 %), 146 (68 %), 135 (100 %).

(±)-(4R*,5R*) 4-Methyl-5-phenylpent-1-en-5-ol **379**

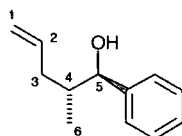

To fluorosilane **378** (68 mg, 0.191 mmol) was added potassium hydrogen carbonate (37 mg, 0.369 mmol) and potassium fluoride (22 mg, 0.380 mmol). The mixture was dissolved in THF/MeOH solution (1:1, 3 ml) and hydrogen peroxide (35 % w/w solution in water, 0.22 ml, 2.28 mmol) was added. The mixture was heated to reflux and stirred for 19 h.¹⁰ The mixture was then allowed to cool to RT and saturated sodium thiosulfate solution (3 ml) was added together with ethyl acetate (3 ml). The aqueous layer was separated and extracted

with ethyl acetate (3 x 3 ml). The combined organic extracts were dried over MgSO_4 , filtered and concentrated. Flash column chromatography, gradient elution (pet. ether/ethyl acetate [29:1], [19:1]) gave the pure title compound as a clear oil (20 mg, 59 %); R_f (pet. ether/ethyl acetate [9:1]) 0.27; ν_{max} (thin film) 3385 (broad, O-H), 3066, 3028, 2972, 2927, 2908, 2878, 1639, 1492, 1453, 1376, 1121, 1074, 1018, 994, 911, 762, 701 cm^{-1} ; δ_{H} (400 MHz; CDCl_3) 7.37-7.32 (5 H, m, *Ar-H*), 5.85 (1 H, m, 2-*H*), 5.07 (1 H, d, J 15.0, 1- H^Z), 5.04 (1 H, d, J 9.5, 1- H^E), 2.42 (1 H, m, 3-*HH*), 2.04-1.84 (2 H, m, J 14.0, 3-*HH* and 4-*H*), 0.75 (3 H, d, J 7.5, 6- H_3); δ_{C} (101 MHz; CDCl_3) 143.29 (*ipso-Ar*), 137.16 (2-*C*), 128.26 (*Ar*), 127.56 (*para-Ar*), 126.68 (*Ar*), 78.67 (5-*C*), 39.94 (3-*C*), 37.02 (4-*C*), 15.67 (6-*C*); m/z (CI) 194 ($\text{M}+\text{NH}_4^+$, 24 %), 176 (M^+ , 100 %), 159 (M^+-OH , 30 %).

1-phenyl-1-trimethylsilyl-2-(prop-2'-yl)-3-methyl-4-hydroxysilacyclohexane 387-388

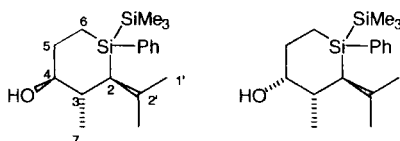

To a solution of borane-THF complex (1 M, 0.66 ml, 0.66 mmol) in THF at 0 °C was added a solution of silacycle **183** (0.19 g, 0.63 mmol) in THF (5 ml) dropwise. The mixture was stirred for 2 h, then warmed to RT and stirred for a further 1 h. Water (0.5 ml) was then added and the evolution of gas bubbles was observed. This was followed by aqueous NaOH solution (3 M, 0.42 ml, 1.26 mmol) and then aqueous hydrogen peroxide solution (35 %, 0.42 ml, 4.18 mmol). The mixture was then heated to 65 °C and stirred for 6 h. Saturated sodium thiosulfate solution (5 ml) was then added. The aqueous layer was separated and extracted with ethyl acetate (3 x 5 ml). The combined organic extracts were dried over MgSO_4 , filtered, concentrated and dried *in vacuo*. Flash column chromatography, gradient elution (pet. ether, pet. ether/ether [14:1], [9:1], [4:1], [2:1]) gave the title compounds as a thick colourless oil, as a mixture of isomers in a ratio of 76 : 24 % (by NMR), (43 mg, 21 %); R_f (pet. ether/ether [9:1]) 0.06; ν_{max} (thin film) 3402, 3310 (broad, O-H), 2966, 2926, 2883, 1464, 1428, 1244, 1098, 1046, 1034, 856, 834, 760, 738, 698 cm^{-1} ; NMR data for major isomer **387**: δ_{H} (400 MHz; CDCl_3) 7.81-7.77 (2 H, m, *Ar-H*), 7.32-7.29 (3 H, m, *Ar-H*), 3.26 (1 H, ddd, J 10.5, 10.0, 3.5, 4-*H*), 3.23-2.15 (2 H, m, $\text{CH}(\text{CH}_3)_2$ and 5-*HH*), 1.71 (1 H, m, 3-*H*), 1.60 (1 H, m, 5-*HH*), 1.21 (1 H, dd, J 11.0, 4.0, 2-*H*), 1.14 (3 H, d, J 6.5, 7- H_3), 1.10 (1 H, dd, J 5.0, 4.0, 6-*HH*), 1.01 (3 H, d, J 6.5, $\text{CH}(\text{CH}_3)_2$), 0.91 (1 H, m, 6-*HH*), 0.75 (3 H, d, J 6.5, $\text{CH}(\text{CH}_3)_2$), 0.30 (9 H, s, $\text{Si}(\text{CH}_3)_3$); δ_{C} (101 MHz; CDCl_3) 139.97 (*Ar*), 134.52 (*Ar*), 128.40 (*Ar*), 127.74 (*Ar*), 77.81 (4-*C*), 41.60 (3-*C*), 38.49 (2-*C*), 33.48 (5-*C*), 28.19 ($\text{CH}(\text{CH}_3)_2$), 23.48 ($\text{CH}(\text{CH}_3)_2$), 22.08 ($\text{CH}(\text{CH}_3)_2$), 18.35 (7-*C*), 9.57 (6-*C*), 0.29 ($\text{Si}(\text{CH}_3)_3$); m/z (ES^+) 343 ($\text{M}+\text{Na}^+$, 100 %); NMR data for minor isomer **388**: δ_{H} (400 MHz;

CDCl_3 (Discernable peaks) 3.89 (1 H, dt, J 8.0, 2.5, 4-*H*), 2.11-1.96 (3 H, m, 5-*HH*, 3-*H* and *CH*(CH_3)₂), 1.45 (1 H, dd, J 8.0, 4.5, 2-*H*), 1.04 (3 H, d, J 7.5, 7-*H*₃), 0.91 (3 H, d, J 7.0, *CH*(CH_3)₂), 0.86 (3 H, d, J 7.0, *CH*(CH_3)₂).

Appendix

Research Conferences Attended

- Apr 2003 'Young Chemists in Industry XII', SCI International Headquarters, 14/15
Belgrave Square, London.
- Dec 2002 'Modern Aspects of Stereochemistry', Sheffield Stereochemistry
- Dec 2001 'Modern Aspects of Stereochemistry', Sheffield Stereochemistry
- Dec 2000 'Modern Aspects of Stereochemistry', Sheffield Stereochemistry

Poster Presentations by the Author

- Mar 2003 Perkin Division North East Annual Meeting, Newcastle, UK
- Dec 2002 Avecia Poster Competition, Durham University, UK
- Dec 2002 Pfizer Organic Chemistry Poster Symposium, London, UK
- Jul 2002 BOSS-9 International Conference, Namur, Belgium
- Apr 2002 Perkin North East Division Meeting, York, UK

Oral Presentations by the Author

- June 2003 3rd Year Ph.D Presentation, University of Durham
- Apr 2003 SCI Postgraduate Symposium (North), Leeds, UK (1st prize)

Papers Published

'Silenes as novel synthetic reagents: Synthesis of diols and lactones from simple alkyldienes', Malcolm B. Berry, Russell J. Griffiths, Mahesh J. Sanganee, Patrick. G. Steel and Daniel K. Whelligan, *Tetrahedron Lett.*, **2003**, *44*, 9135-9138

'Novel Synthesis of Aryltris(trimethylsilyl)silanes', Mahesh J. Sanganee, Patrick. G. Steel and Daniel K. Whelligan, *J. Org. Chem.*, **2003**, *68*, 3337-3339

References

- 1 S. Patai and Z. Rappoport, 'The Chemistry of Organic Silicon Compounds', Wiley-Interscience, Chichester, **1989**.
- 2 A. G. Brook and M. A. Brook, *Adv. Organomet. Chem.*, **1996**, 39, 71.
- 3 L. E. Gusel'nikov and N. S. Nametkin, *Chem. Rev.*, **1979**, 79, 529.
- 4 N. Wiberg, *J. Organomet. Chem.*, **1984**, 273, 141.
- 5 J. Hermanns and B. Schmidt, *J. Chem. Soc., Perkin Trans. 1*, **1998**, 2209.
- 6 R. West, *Polyhedron*, **2002**, 21, 467.
- 7 J. Clayden, N. Greeves, S. Warren, and P. Wothers, 'Organic Chemistry', ed. M. Rodgers, Oxford University Press Inc., New York, **2001**.
- 8 S. E. Thomas, 'Organic Synthesis The Roles of Boron and Silicon', Oxford University Press Inc., New York, **1997**.
- 9 E. W. Colvin, 'Silicon Reagents in Organic Synthesis', Academic Press Ltd., London, **1988**.
- 10 R. Griffiths, PhD Thesis, 'Novel Synthetic Reagents for Olefin Functionalisation', University of Durham, **2000**.
- 11 J. March, 'Advanced Organic Chemistry', Wiley-Interscience, New York, **1992**.
- 12 G. Raabe and J. Michl, 'Multiple Bonds to Silicon' in 'The Chemistry of Organosilicon Compounds Part 2', ed. S. Patai and Z. Rappoport, Wiley, Chichester, **1989**.
- 13 W. Schlenck and J. Renning, *Justus Liebigs Ann. Chem.*, **1912**, 394, 221.
- 14 F. S. Kipping, *J. Chem. Soc.*, **1927**, 104.
- 15 R. West, *J. Am. Chem. Soc.*, **1954**, 76, 6012.
- 16 L. E. Gusel'nikov and M. C. Flowers, *Chem. Comm.*, **1967**, 864.
- 17 A. K. Mal'tsev, V. N. Khabashesku, and O. M. Nefedov, *Izv. Akad. Nauk SSSR, Ser. Khim.*, **1976**, 1193.
- 18 O. M. Nefedov, A. K. Maltsev, V. N. Khabashesku, and V. A. Korolev, *J. Organomet. Chem.*, **1980**, 201, 123.
- 19 L. E. Gusel'nikov, V. V. Volkova, V. G. Avakyan, and N. S. Nametkin, *J. Organomet. Chem.*, **1980**, 201, 137.
- 20 O. L. Chapman, C.-C. Chang, J. Kolc, M. E. Jung, J. A. Lowe, T. J. Barton, and M. L. Tumey, *J. Am. Chem. Soc.*, **1976**, 98, 7844.
- 21 M. R. Chedekel, M. Skoglund, R. L. Creeger, and H. Shechter, *J. Am. Chem. Soc.*, **1976**, 98, 7846.
- 22 H. B. Schlegel, S. Wolfe, and K. Mislow, *J. Chem. Soc., Chem. Commun.*, **1975**, 246.
- 23 A. G. Brook, J. W. Harris, J. Lennon, and M. E. Sheikh, *J. Am. Chem. Soc.*, **1979**, 101, 83.
- 24 A. G. Brook, S. C. Nyburg, F. Abdesaken, B. Gutekunst, G. Gutekunst, R. Krishna, M. R. Kallury, Y. C. Poon, Y. M. Chang, and W. Wong-Ng, *J. Am. Chem. Soc.*, **1982**, 104, 5667.
- 25 A. G. Brook, F. Abdesaken, B. Gutekunst, G. Gutekunst, R. Kallury, Y. Poon, Y. Chang, and W. Nong-Ng, *J. Chem. Soc., Chem. Commun.*, **1981**, 191.
- 26 H. F. Schaefer, *Acc. Chem. Res.*, **1982**, 15, 283.
- 27 A. G. Brook, *J. Organomet. Chem.*, **1986**, 300, 21.
- 28 N. Wiberg and G. Wagner, *Angew. Chem. Int. Ed. Engl.*, **1983**, 22, 1005.
- 29 N. Wiberg, G. Wagner, G. Reder, J. Riede, and G. Muller, *Organometallics*, **1987**, 6, 35.
- 30 N. Wiberg and H. Köpf, *J. Organomet. Chem.*, **1986**, 315, 9.
- 31 K. Schmohl, H. Reinke, and H. Oehme, *Eur. J. Inorg. Chem.*, **2001**, 481.

- 32 M. Pötter, U. Bäumer, M. Mickoleit, R. Kempe, and H. Oehme, *J. Organomet. Chem.*, **2001**, 621, 261.
- 33 M. Mickoleit, R. Kempe, and H. Oehme, *Chem. Eur. J.*, **2001**, 7, 987.
- 34 N. Wiberg, G. Wagner, and G. Müller, *Angew. Chem. Int. Ed. Engl.*, **1985**, 24, 229.
- 35 N. Wiberg and G. Wagner, *Chem. Ber.*, **1986**, 119, 1467.
- 36 N. Wiberg, T. Passler, and K. Polborn, *J. Organomet. Chem.*, **1997**, 531, 47.
- 37 G. Delpon-Lacaze and C. Couret, *J. Organomet. Chem.*, **1994**, 480, C14.
- 38 G. Delpon-Lacaze, C. d. Battisti, and C. Couret, *J. Organomet. Chem.*, **1996**, 514, 59.
- 39 Y. Apeloig, M. Bendikov, M. Yuzefovich, M. Nakash, and D. Bravo-Zhivotovskii, *J. Am. Chem. Soc.*, **1996**, 118, 12228.
- 40 M. Bendikov, Y. Apeloig, S. Bukalov, I. Garbuzova, and L. Leites, *J. Phys. Chem. A*, **2002**, 106, 4880.
- 41 J. Buffy, R. West, M. Bendikov, and Y. Apeloig, *J. Am. Chem. Soc.*, **2001**, 123, 978.
- 42 K. Sakamoto, J. Ogasawara, Y. Kon, T. Sunagawa, C. Kabuto, and M. Kira, *Angew. Chem. Int. Ed.*, **2002**, 41, 1402.
- 43 V. V. Volkova, E. A. Volnina, E. N. Buravtseva, and L. E. Gusel'nikov, Abstracts Xth International Symposium on Organosilicon Chemistry, Poznan, Poland, 1993, p. 170.
- 44 G. Maier, G. Mihm, and H. P. Resienauer, *Chem. Ber.*, **1984**, 117, 2351.
- 45 T. J. Barton, S. A. Burns, I. M. T. Davidson, S. I. Maghsoodi, and I. T. Wood, *J. Am. Chem. Soc.*, **1984**, 106, 6367.
- 46 I. M. T. Davidson, K. J. Hughes, and S. Ijadi-Magshood, *Organometallics*, **1987**, 6, 646.
- 47 T. J. Barton and W. D. Wulff, *J. Am. Chem. Soc.*, **1979**, 101, 2735.
- 48 T. J. Barton and J. A. Kilgour, *J. Am. Chem. Soc.*, **1976**, 98, 7746.
- 49 C. Eaborn, D. A. R. Happer, P. B. Hitchcock, S. P. Hopper, K. D. Safa, S. S. Washburne, and D. R. M. Walton, *J. Organomet. Chem.*, **1980**, 186, 309.
- 50 L. E. Gusel'nikov, Y. P. Polyakov, E. A. Volnina, and N. S. Nametkin, *J. Organomet. Chem.*, **1985**, 292, 189.
- 51 J. C. Calandra, M. L. Keplinger, E. J. Hobbs, and E. J. Tyler, *Div. Polymer Chem., Am. Chem. Soc.*, **1976**, 17, 12.
- 52 D. Bravo-Zhivotovskii, S. Melamed, M. Kapon, and Y. Apeloig, *Organometallics*, **2002**, 21, 2049.
- 53 M. Ishikawa, T. Fuchikami, and M. Kumada, *J. Organomet. Chem.*, **1978**, 149, 37.
- 54 W. Ando, A. Sekiguchi, T. Hagiwara, T. Migita, V. Chowdhry, F. H. Westheimer, S. L. Kammula, M. Green, and M. Jones, *J. Am. Chem. Soc.*, **1979**, 101, 6393.
- 55 T. J. Barton and K. Hoekman, *J. Am. Chem. Soc.*, **1980**, 102, 1584.
- 56 A. G. Brook and J. W. Harris, *J. Am. Chem. Soc.*, **1976**, 98, 3381.
- 57 K. M. Baines, A. G. Brook, R. R. Ford, P. D. Lickiss, A. K. Saxena, W. J. Chatterton, J. F. Sawyer, and B. A. Behnam, *Organometallics*, **1989**, 8, 693.
- 58 D. Tzeng, R. H. Fong, H. S. D. Soysa, and W. P. Weber, *J. Organomet. Chem.*, **1981**, 219, 153.
- 59 Y. Nakadaira, S. Kanouchi, and H. Sakurai, *J. Am. Chem. Soc.*, **1974**, 96, 5621.
- 60 B. J. Cornett, K. Y. Choo, and P. P. Gaspar, *J. Am. Chem. Soc.*, **1980**, 102, 377.
- 61 P. R. Jones, M. E. Lee, and L. T. Lin, *Organometallics*, **1983**, 2, 1039.
- 62 N. Wiberg, G. Preiner, O. Scheida, and G. Fischer, *Chem. Ber.*, **1981**, 114, 3505.
- 63 D. J. Peterson, *J. Org. Chem.*, **1968**, 33, 780.
- 64 V. G. Becker, W. Uhl, and H.-J. Wessely, *Z. Anorg. Allg. Chem.*, **1981**, 479, 41.
- 65 H. Oehme and R. Wustrack, *Z. Anorg. Allg. Chem.*, **1987**, 552, 215.
- 66 H. Oehme and R. Wustrack, *J. Organomet. Chem.*, **1988**, 352, 95.

- 67 H. Oehme, R. Wustrack, A. Heine, G. M. Sheldrick, and D. Stalke, *J. Organomet. Chem.*, **1993**, 452, 33.
- 68 C. Krempner, H. Reinke, and H. Oehme, *Chem. Ber.*, **1995**, 128, 143.
- 69 Y. Apeloig, D. Bravo-Zhivotovskii, V. Braude, A. Stanger, and M. Kapon, *Organometallics*, **1992**, 11, 2326.
- 70 K. Sternberg, H. Reinke, and H. Oehme, *Z. Anorg. Allg. Chem.*, **1999**, 625, 467.
- 71 J. Ohshita, Y. Masaoka, and M. Ishikawa, *Organometallics*, **1991**, 10, 3775.
- 72 J. Ohshita, Y. Masaoka, S. Masaoka, M. Ishikawa, A. Tachibana, T. Yano, and T. Yamabe, *J. Organomet. Chem.*, **1994**, 473, 15.
- 73 J. Ohshita, E. Nekoda, S. Masaoka, and M. Ishikawa, *J. Organomet. Chem.*, **1997**, 544, 49.
- 74 J. Ohshita, S. Masaoka, Y. Morimoto, M. Sano, and M. Ishikawa, *Organometallics*, **1997**, 16, 1123.
- 75 C. Krempner and H. Oehme, *J. Organomet. Chem.*, **1994**, 464, C7.
- 76 H. Oehme, H. Reinke, and F. Luderer, *Chem. Ber.*, **1996**, 129, 15.
- 77 F. Luderer, H. Reinke, and H. Oehme, *Z. Anorg. Allg. Chem.*, **1998**, 624, 1519.
- 78 H. Oehme, C. Krempner, and H. Reinke, *Chem. Ber.*, **1995**, 128, 1083.
- 79 H. Reinke, F. Luderer, and H. Oehme, *J. Organomet. Chem.*, **1996**, 510, 181.
- 80 K. Sternberg, M. Michalik, and H. Oehme, *J. Organomet. Chem.*, **1997**, 533, 265.
- 81 H. Oehme and K. Sternberg, *Eur. J. Inorg. Chem.*, **1998**, 177.
- 82 N. Auner, C.-R. Heikenwalder, and W. Ziche, *Chem. Ber.*, **1993**, 126, 2177.
- 83 D. Hoffmann, H. Reinke, and H. Oehme, *J. Organomet. Chem.*, **1999**, 585, 189.
- 84 D. Hoffmann, T. Gross, R. Kempe, and H. Oehme, *J. Organomet. Chem.*, **2000**, 598, 395.
- 85 C. Krempner, D. Hoffman, H. Oehme, and R. Kempe, *Organometallics*, **1997**, 16, 1828.
- 86 K. Schmohl, M. Blach, H. Reinke, R. Kempe, and H. Oehme, *Eur. J. Inorg. Chem.*, **1998**, 1667.
- 87 I. Fleming, 'Pericyclic Reactions', Oxford University Press Inc., New York, **1999**.
- 88 A. G. Brook, K. Vorspohl, R. R. Ford, M. Hesse, and W. J. Chatterton, *Organometallics*, **1987**, 6, 2128.
- 89 N. Auner, W. Ziche, and E. Herdtweck, *J. Organomet. Chem.*, **1992**, 426, 1.
- 90 N. Auner, C. Seidenschwarz, E. Herdtweck, and N. Sewald, *Angew. Chem. Int. Ed. Engl.*, **1991**, 30, 444.
- 91 N. Auner, C. Seidenschwarz, and N. Sewald, *Organometallics*, **1992**, 11, 1137.
- 92 N. Sewald, W. Ziche, A. Wolff, and N. Auner, *Organometallics*, **1993**, 12, 4123.
- 93 N. Auner, *J. Organomet. Chem.*, **1988**, 353, 275.
- 94 I. El-Sayed, T. Guliashvili, R. Hazell, A. Gogoll, and H. Ottosson, *Org. Lett.*, **2002**, 4, 1915.
- 95 N. Auner, *J. Organomet. Chem.*, **1987**, 336, 83.
- 96 Y. Apeloig and M. Karni, *J. Am. Chem. Soc.*, **1984**, 106, 6676.
- 97 N. Wiberg, K. Schurz, and G. Fischer, *Chem. Ber.*, **1986**, 119, 3498.
- 98 A. S. Batsanov, I. M. Clarkson, J. A. K. Howard, and P. G. Steel, *Tetrahedron Lett.*, **1996**, 37, 2491.
- 99 A. G. Brook, W. J. Chatterton, J. F. Sawyer, D. W. Hughes, and K. Vorspohl, *Organometallics*, **1987**, 6, 1246.
- 100 A. G. Brook, W. J. Chatterton, and R. Kumarathasan, *Organometallics*, **1993**, 12, 3666.
- 101 G. Maas, M. Alt, K. Schneider, and A. Fronda, *Chem. Ber.*, **1991**, 124, 1295.
- 102 A. G. Brook, S. S. Hu, W. J. Chatterton, and A. J. Lough, *Organometallics*, **1991**, 10, 2752.
- 103 T. L. Morkin and W. J. Leigh, *Acc. Chem. Res.*, **2001**, 34, 129.

- 104 T. Veszprémi, M. Takahashi, B. Hajgató, and M. Kira, *J. Am. Chem. Soc.*, **2001**, *123*, 6629.
- 105 T. L. Morkin, W. J. Leigh, T. T. Tidwell, and A. D. Allen, *Organometallics*, **2001**, *20*, 5707.
- 106 A. G. Brook, P. Chiu, J. McClenaghan, and A. J. Lough, *Organometallics*, **1991**, *10*, 3292.
- 107 M. A. Cook, C. Eaborn, and D. R. M. Walton, *J. Organomet. Chem.*, **1970**, *23*, 85.
- 108 L. F. Brough and R. West, *J. Organomet. Chem.*, **1982**, 113.
- 109 H. J. Sipe and R. West, *J. Organomet. Chem.*, **1974**, *70*, 353.
- 110 H. Shizuka and H. Obuchi, *J. Chem. Soc., Faraday Trans. 1*, **1984**, *80*, 383.
- 111 H. Shizuka, Y. Sato, and Y. Ueki, *J. Chem. Soc., Faraday Trans. 1*, **1984**, *80*, 341.
- 112 M. Ishikawa, K. Nakagawa, and M. Kumada, *J. Organomet. Chem.*, **1980**, *190*, 117.
- 113 K. Oka and R. Nakao, *J. Organomet. Chem.*, **1990**, *390*, 7.
- 114 T. Kusukawa and W. Ando, *J. Organomet. Chem.*, **1998**, 559, 11.
- 115 U. Herzog and G. Roewer, *J. Organomet. Chem.*, **1997**, *544*, 217.
- 116 H. Gilman and C. L. Smith, *J. Am. Chem. Soc.*, **1964**, *86*, 1454.
- 117 H. Gilman and C. L. Smith, *J. Organomet. Chem.*, **1968**, *14*, 91.
- 118 G. Gutekunst and A. G. Brook, *J. Organomet. Chem.*, **1982**, *225*, 1.
- 119 H. Gilman, J. M. Holmes, and C. L. Smith, *Chem. Ind.*, **1965**, 848.
- 120 C. Eaborn, 'Organosilicon Compounds', Butterworth, London, **1960**.
- 121 H. Gilman and R. L. Harrell, *J. Organomet. Chem.*, **1966**, *5*, 199.
- 122 D. B. Puranik and M. J. Fink, *J. Chem. Crystallography*, **1994**, *24*, 293.
- 123 U. Baumeister, K. Schenzel, R. Zink, and K. Hassler, *J. Organometallic Chem.*, **1997**, *543*, 117.
- 124 W. C. Still, *J. Org. Chem.*, **1976**, *41*, 3063.
- 125 T. Mukhopadhyay and D. Seebach, *Helv. Chim. Acta*, **1982**, *65*, 385.
- 126 M. Bochmann, M. L. H. Green, A. K. Powell, J. SaBmannshausen, M. U. Triller, and S. Wocadlo, *J. Chem. Soc., Dalton Trans.*, **1999**, 43.
- 127 H. Bock, J. Meuret, and K. Ruppert, *J. Organomet. Chem.*, **1993**, *445*, 19.
- 128 J. Watson and J. Eastham, *J. Organomet. Chem.*, **1967**, *9*, 165.
- 129 J.-P. Dulcère and J. Rodriguez, *Synth. Commun.*, **1990**, *20*, 1893.
- 130 C. Marschner, *Eur. J. Inorg. Chem.*, **1998**, 221.
- 131 Y. Matsunaga and K. Imafuku, *Bull. Chem. Soc. Jpn.*, **1992**, *65*, 295.
- 132 A. Naka, M. Hayashi, S. Okazaki, and M. Ishikawa, *Organometallics*, **1994**, *13*, 4994.
- 133 M. Suginome, H. Oike, S.-S. Park, and Y. Ito, *Bull. Chem. Soc. Jpn.*, **1996**, *69*, 289.
- 134 F. Ozawa, M. Sugawara, and T. Hayashi, *Organometallics*, **1994**, *13*, 3237.
- 135 S. Cros, B. Bennetau, J. Dunoguès, and P. Babin, *J. Organomet. Chem.*, **1994**, *468*, 69.
- 136 P. Babin, B. Bennetau, M. Theurig, and J. Dunoguès, *J. Organomet. Chem.*, **1993**, *446*, 135.
- 137 L. J. Gooben and A.-R. S. Ferwanah, *Synlett*, **2000**, *12*, 1801.
- 138 T. Hayashi, M. Konishi, M. Fukushima, T. Mise, M. Kagotani, M. Tajika, and M. Kumada, *J. Am. Chem. Soc.*, **1982**, *104*, 180.
- 139 T. Hayashi, M. Konishi, Y. Kobori, M. Kumada, T. Higuchi, and K. Hirotsu, *J. Am. Chem. Soc.*, **1984**, *106*, 158.
- 140 H. Hayami, M. Sato, S. Kanemoto, Y. Morizawa, K. Oshima, and H. Nozaki, *J. Am. Chem. Soc.*, **1983**, *105*, 4492.
- 141 Y. Okuda, Y. Morizawa, K. Oshima, and H. Nozaki, *Tetrahedron Lett.*, **1984**, *25*, 2483.
- 142 H. C. Holtkamp, G. Schat, C. Blomberg, and F. Bickelhaupt, *J. Organomet. Chem.*, **1982**, *240*, 1.

- 143 P. R. Markies, R. M. Altink, A. Villena, O. S. Akkerman, and F. Bickelhaupt, *J. Organomet. Chem.*, **1991**, *402*, 289.
- 144 Y. Ogata and A. Kawasaki, *Tetrahedron*, **1969**, *25*, 929.
- 145 M. Bordeau, J. Dédier, E. Frainnet, J.-P. Fayet, and P. Mauret, *J. Organomet. Chem.*, **1973**, *59*, 125.
- 146 A. E. Canavan and C. Eaborn, *J. Chem. Soc.*, **1962**, 592.
- 147 G. A. Molander, E. R. Burkhardt, and P. Weinig, *J. Org. Chem.*, **1990**, *55*, 4990.
- 148 G. A. Molander and C. Köllner, *J. Org. Chem.*, **2000**, *65*, 8333.
- 149 K. Takaki, T. Maeda, and M. Ishikawa, *J. Org. Chem.*, **1989**, *54*, 58.
- 150 D. J. Ager, I. Fleming, and S. K. Patel, *J. Chem. Soc., Perkin Trans. I*, **1981**, 2520.
- 151 E. C. Ashby, G. F. Willard, and A. B. Goel, *J. Org. Chem.*, **1979**, *44*, 1221.
- 152 D. W. Goebel, J. L. Hencher, and J. P. Oliver, *Organometallics*, **1983**, *2*, 746.
- 153 K. W. Henderson, R. E. Mulvey, W. Clegg, and P. A. O'Neil, *J. Organomet. Chem.*, **1992**, *439*, 237.
- 154 R. Goddard, C. Krüger, N. A. Ramadan, and A. Ritter, *Angew. Chem. Int. Ed. Engl.*, **1995**, *34*, 1030.
- 155 D. Wittenberg and H. Gilman, *J. Am. Chem. Soc.*, **1958**, *80*, 4529.
- 156 J. A. Soderquist, I. Rivera, and A. Negron, *J. Org. Chem.*, **1989**, *54*, 4051.
- 157 J. A. Soderquist and H. C. Brown, *J. Org. Chem.*, **1980**, *45*, 3571.
- 158 J. W. Wilt, F. G. Belmonte, and P. A. Zieske, *J. Am. Chem. Soc.*, **1983**, *105*, 5665.
- 159 S. Bienz and A. Chapeaurouge, *Helv. Chim. Acta*, **1991**, *74*, 1477.
- 160 R. K. Crossland and K. L. Servis, *J. Org. Chem.*, **1970**, *35*, 3195.
- 161 K. Tamao, N. Ishida, T. Tanaka, and M. Kumada, *Organometallics*, **1983**, *2*, 1694.
- 162 K. Tamao, T. Kakui, M. Akita, T. Iwahara, R. Kanatani, J. Yoshida, and M. Kumada, *Tetrahedron*, **1983**, *39*, 983.
- 163 G. R. Jones and Y. Landais, *Tetrahedron*, **1996**, *52*, 7599.
- 164 K. Tamao, T. Hayashi, and Y. Ito, 'Frontiers of Organosilicon Chemistry' in , ed. A. R. Bassindale and P. P. Gaspar, Royal Society of Chemistry, Cambridge, **1991**.
- 165 I. Fleming, R. Henning, and H. Plaut, *J. Chem. Soc., Chem. Commun.*, **1984**, 29.
- 166 I. Fleming and P. E. J. Sanderson, *Tetrahedron Lett.*, **1987**, *28*, 4229.
- 167 I. Fleming, R. Henning, D. C. Parker, H. E. Plaut, and P. E. J. Sanderson, *J. Chem. Soc., Perkin Trans. I*, **1995**, 317.
- 168 R. Carter, K. Hodgetts, J. McKenna, P. Magnus, and S. Wren, *Tetrahedron*, **2000**, *56*, 4367.
- 169 W. P. Griffith, S. V. Ley, G. P. Whitcombe, and A. D. White, *J. Chem. Soc., Chem. Commun.*, **1987**, 1625.
- 170 S. V. Ley, J. Norman, W. P. Griffith, and S. P. Marsden, *Synthesis*, **1994**, 639.
- 171 M. T. Crimmins, R. S. Al-awar, I. M. Vallin, J. W G Hollis, R. O'Mahony, J. G. Lever, and D. M. Bankaitis-Davis, *J. Am. Chem. Soc.*, **1996**, *118*, 7513.
- 172 F. Kazmierczak and P. Helquist, *J. Org. Chem.*, **1989**, *54*, 3988.
- 173 E. L. Eliel and S. H. Wilen, 'Stereochemistry of Organic Compounds', John Wiley and Sons, Inc., New York, **1994**.
- 174 M. Omote, T. Tokita, Y. Shimizu, I. Imae, E. Shirakawa, and Y. Kawakami, *J. Organomet. Chem.*, **2000**, *611*, 20.
- 175 C. Shih, E. L. Fritzen, and J. S. Swenton, *J. Org. Chem.*, **1980**, *45*, 4462.
- 176 M. Lounasmaa and P. Hanhinen, *Heterocycles*, **1999**, *51*, 2227.
- 177 S. Siegel and G. V. Smith, *J. Am. Chem. Soc.*, **1960**, *82*, 6082.
- 178 R. H. Crabtree and M. W. Davis, *J. Org. Chem.*, **1986**, *51*, 2655.
- 179 P. N. Rylander, 'Hydrogenation Methods', Academic Press Ltd., **1990**.
- 180 A. Barbero, D. C. Blakemore, I. Fleming, and R. N. Wesley, *J. Chem. Soc., Perkin Trans I*, **1997**, 1329.
- 181 G.-Q. Lin and W.-C. Xu, *Tetrahedron*, **1996**, *52*, 5907.

- 182 I. Shin, H. Zhou, N. Loida, and H. Liu, *J. Org. Chem.*, **1993**, 58, 2923.
183 S. V. N. Raju and B. Pandey, *Tetrahedron Lett.*, **1994**, 35, 1439.
184 N. J. Cusack, C. B. Reese, A. C. Risius, and B. Roozpeikar, *Tetrahedron*, **1976**, 32, 2157.
185 J. W. Suggs, S. D. Cox, R. H. Crabtree, and J. M. Quirk, *Tetrahedron Lett.*, **1981**, 22, 303.
186 R. H. Crabtree and M. W. Davies, *Organometallics*, **1983**, 2, 681.
187 R. H. Crabtree, P. C. Demou, D. Eden, J. M. Mihelcic, C. A. Parnell, J. M. Quirk, and G. E. Morris, *J. Am. Chem. Soc.*, **1982**, 104, 6994.
188 W. R. Roush, M. L. Reilly, K. Koyama, and B. B. Brown, *J. Org. Chem.*, **1997**, 62, 8708.
189 B. A. Stoochnoff and N. L. Benoiton, *Tetrahedron Lett.*, **1973**, 1, 21.
190 S. E. deSousa, PhD Thesis, , York, **2000**.
191 S. V. Ley, N. J. Anthony, A. Armstrong, M. G. Brasca, T. Clarke, D. Culshaw, C. Greck, P. Grice, A. B. Jones, B. Lygo, A. Madin, R. N. Sheppard, A. M. Z. Slawin, and D. J. Williams, *Tetrahedron*, **1989**, 45, 7161.
192 N. Asao, T. Ohishi, K. Sato, and Y. Yamamoto, *Tetrahedron*, **2002**, 58, 8195.
193 J. Hermanns and B. Schmidt, *J. Chem. Soc., Perkin Trans. 1*, **1999**, 81.
194 J. J. Eisch, *Organometal. Synth.*, **1981**, 2, 110.
195 D. D. Perrin and W. L. F. Armarego, 'Purification of Laboratory Chemicals', Pergamon Press plc, Oxford, **1988**.
196 M. Ishikawa, K. Nakagawa, and M. Kumada, *J. Organomet. Chem.*, **1979**, 178, 105.
197 X. Creary, *J. Org. Chem.*, **1987**, 52, 5026.
198 B. Mudryk and T. Cohen, *J. Am. Chem. Soc.*, **1993**, 115, 3855.
199 M. Reggelin, P. Tebben, and D. Hoppe, *Tetrahedron Lett.*, **1989**, 30, 2915.
200 D. H. Davies, N. A. Haire, J. Hall, and E. H. Smith, *Tetrahedron*, **1992**, 48, 7839.
201 G. Carr, C. Dean, and D. Whittaker, *J. Chem. Soc., Perkin. Trans. II*, **1989**, 71.
202 W. Barth and L. A. Paquette, *J. Org. Chem.*, **1985**, 50, 2438.
203 K. Tamao, H. Matsumoto, T. Kakui, and M. Kumada, *Tetrahedron Lett.*, **1979**, 13, 1137.

