



## Durham E-Theses

---

### *Bogomol'nyi equations on constant curvature spaces*

Hickin, D. G.

#### How to cite:

---

Hickin, D. G. (2004) *Bogomol'nyi equations on constant curvature spaces*, Durham theses, Durham University. Available at Durham E-Theses Online: <http://etheses.dur.ac.uk/3037/>

#### Use policy

---

The full-text may be used and/or reproduced, and given to third parties in any format or medium, without prior permission or charge, for personal research or study, educational, or not-for-profit purposes provided that:

- a full bibliographic reference is made to the original source
- a [link](#) is made to the metadata record in Durham E-Theses
- the full-text is not changed in any way

The full-text must not be sold in any format or medium without the formal permission of the copyright holders.

Please consult the [full Durham E-Theses policy](#) for further details.

# Bogomol'nyi Equations on Constant Curvature Spaces

D. G. Hickin

*A copyright of this thesis rests  
with the author. No quotation  
from it should be published  
without his prior written consent  
and information derived from it  
should be acknowledged.*

A thesis presented for the degree of  
Doctor of Philosophy



Department of Mathematical Sciences  
University of Durham  
England

July 2004



20 APR 2005

*Dedicated to*

My family, for all their support over the years.

# Bogomol'nyi Equations on Constant Curvature Spaces

D. G. Hickin

Submitted for the degree of Doctor of Philosophy

July 2004

## Abstract

This thesis is concerned with the anti-self-dual Yang-Mills equations and their reductions to Bogomol'nyi equations on constant curvature spaces.

Chapters 1 and 2 contain introductory material. Chapter 1 discusses the origin of the equations in particle physics and their role in integrable systems. Chapter 2 describes the equations and the reduction process and outlines the construction of solutions via the twistor transform. In Chapter 3 we consider Bogomol'nyi equations on  $(2 + 1)$ -dimensional manifolds and show that for constant curvature space-times the equations are integrable and consider solutions in the negative scalar curvature case. In Chapter 4 we cover the negative scalar curvature case in more detail, constructing a number of soliton solutions including non-trivial scattering and consider the zero-curvature limit. In Chapter 5 we consider Bogomol'nyi equations in 3-dimensional hyperbolic space, derive an ansatz for solutions of the equation and use it to construct a number of new solutions. Chapter 6 contains concluding remarks.

# Declaration

The work in this thesis is based on research carried out at the Department of Mathematical Sciences, University of Durham, England. No part of this thesis has been submitted elsewhere for any other degree or qualification and it all my own work unless referenced to the contrary in the text. No originality is claimed for Chapters 1 and 2, Sections 3.1, 4.1 and 5.1, and for Appendix A.

**Copyright © 2004 by D. G. Hickin.**

“The copyright of this thesis rests with the author. No quotations from it should be published without the author’s prior written consent and information derived from it should be acknowledged”.

# Acknowledgements

I would like to thank my family for all their help and support during my PhD. I would also like to thank my supervisor Professor R. S. Ward for his guidance, the Engineering and Physical Sciences Council for financial support, M. Imran for his assistance with L<sup>A</sup>T<sub>E</sub>X, all the staff and students of the University of Durham who assisted me during my studies, and everyone who helped me during my time at the University of Warwick, especially Mario Micallef.

# Contents

<b>Abstract</b>	<b>iii</b>
<b>Declaration</b>	<b>iv</b>
<b>Acknowledgements</b>	<b>v</b>
<b>1 Introduction</b>	<b>1</b>
1.1 Instantons and Monopoles . . . . .	3
1.2 Integrable Systems . . . . .	15
<b>2 Twistors and the ASDYM Equations</b>	<b>18</b>
2.1 The ASDYM Equations . . . . .	18
2.2 Twistor Methods . . . . .	21
2.3 Reductions . . . . .	29
2.4 Minitwistor Spaces . . . . .	35
2.5 Application to Instantons and Monopoles . . . . .	38
<b>3 Bogomol'nyi Equations on Constant Curvature Space-times</b>	<b>50</b>
3.1 Minkowski Space-time . . . . .	51
3.2 Anti-deSitter Space-time . . . . .	56
3.3 deSitter Space-time . . . . .	63

3.4	Solutions for ADS Space-time . . . . .	68
3.5	Bundles for ADS Space-time . . . . .	70
<b>4</b>	<b>Solutions of the Bogomol'nyi Equations on ADS Space-time</b>	<b>74</b>
4.1	Solutions for Minkowski Space-time . . . . .	74
4.2	1-Solitons . . . . .	80
4.3	Trivial Scattering . . . . .	85
4.4	Limiting Cases and Non-trivial Scattering . . . . .	90
4.5	Zero-Curvature Limit . . . . .	99
<b>5</b>	<b>Hyperbolic Monopoles</b>	<b>104</b>
5.1	Hyperbolic Monopoles and Instantons . . . . .	105
5.2	An Ansatz for Hyperbolic Monopoles . . . . .	110
5.3	1-Monopole Solutions . . . . .	112
5.4	2-Monopole Solutions . . . . .	113
5.5	Higher-charge Monopoles . . . . .	116
5.6	Ansätze for Higher- $p$ Monopoles . . . . .	118
<b>6</b>	<b>Outlook</b>	<b>121</b>
	<b>Appendix</b>	<b>123</b>
<b>A</b>	<b>Vector Bundles and Connections</b>	<b>123</b>
A.1	Vector Bundles . . . . .	123
A.2	Principal Bundles, Associated Bundles and the Adjoint Bundle . . . .	125
A.3	Connections and Curvature . . . . .	126
	<b>Bibliography</b>	<b>129</b>



# List of Figures

4.1	Example 4.4 — $\ \Phi\ ^2$ for various values of $t$ . . . . .	84
4.2	Soliton paths for various values of the scale parameter $a$ . . . . .	85
4.3	Example 4.4 — $\ \Phi\ ^2$ for various values of $s$ . . . . .	86
4.4	Example 4.4 — Energy density $\mathcal{E}$ at $t = 0$ . . . . .	87
4.5	Example 4.5 — $\ \Phi\ ^2$ at $s = 0$ for various values of $a$ . . . . .	88
4.6	Example 4.6 — $\ \Phi\ ^2$ for various values of $s$ . . . . .	89
4.7	Example 4.7 — $\ \Phi\ ^2$ at $s = 0$ . . . . .	91
4.8	Example 4.8 — $\ \Phi\ ^2$ at $t = 0$ . . . . .	92
4.9	Example 4.8 — $\ \Phi\ ^2$ at $s = 0$ . . . . .	93
4.10	Example 4.9 — $\ \Phi\ ^2$ at $s = 0.64$ for various values of $a$ . . . . .	96
4.11	90° scattering. Example 4.10 — $\ \Phi\ ^2$ for various values of $s$ . . . . .	97
4.12	60° scattering. Example 4.11 — $\ \Phi\ ^2$ for various values of $s$ . . . . .	98
5.1	A monopole of charge 1. . . . .	113
5.2	A number of 2-monopole solutions. . . . .	115
5.3	An axially-symmetric monopole of charge 2. . . . .	116
5.4	An axially-symmetric monopole of charge 3. . . . .	117
5.5	A 2-monopole / 1-monopole configuration . . . . .	118

# Chapter 1

## Introduction

This thesis is concerned with the anti-self-dual Yang-Mills equations and their reductions, in particular their reduction to Bogomol'nyi equations.

The equations have been of interest to mathematicians and physicists for a number of years. They first arose in the study of nonabelian gauge theories (Yang-Mills theories) in elementary particle physics. These theories in their quantised form are used to model the interaction between matter by the strong and electro-weak forces. The Euler-Lagrange equations of the theory are in general difficult to solve, however for fields satisfying the simpler anti-self-dual Yang-Mills (ASDYM) equations the Euler-Lagrange equations are automatically satisfied. Instantons, finite action solutions in Euclidean space  $\mathbb{E}^4$ , provide the dominant contributions to the Euclidean functional integrals and play a role in a number of calculations in the quantum theory.

The second application of the ASDYM equations in theoretical physics is to magnetic monopoles. These are soliton solutions of certain Yang-Mills-Higgs gauge theories classified by a topological charge — the monopole number. In the full quantum theory these solutions correspond to particle states. From a distance they resemble a configuration of magnetic charges, the total charge being proportional to the monopole number. In the limit when the Higgs potential of the theory is taken to be zero, the Prasad-Sommerfield limit, the monopoles correspond to solutions of the Bogomol'nyi equations in  $\mathbb{E}^3$  and these in turn correspond to solutions of



the ASDYM equations in  $\mathbb{E}^4$  invariant under a 1-dimensional group of translations. These are not instantons though since they have infinite action.

A key feature of the ASDYM equations is that they are an example of an integrable system. Integrability is in general difficult to define, but in this case it is a consequence of Ward's version of the twistor transform. This relates solutions of the ASDYM equations to holomorphic vector bundles over a complex 3-manifold, the twistor space, which is all or part of the complex projective space  $\mathbb{C}\mathbb{P}^3$ . The Bogomol'nyi equations in  $\mathbb{E}^3$  are integrable since they are obtained from the ASDYM equations by imposing symmetry. This reduction takes place at the twistor level too —the solutions correspond to holomorphic vector bundles over a complex 2-manifold, namely the holomorphic tangent bundle of the Riemann sphere.

This suggests a programme of obtaining integrable systems from the ASDYM equations by imposing (conformal) symmetries. A number of well known integrable systems, including the Korteweg-deVries (KdV), nonlinear Schrödinger (NLS) and sine-Gordon (SG) equations, can all be obtained this way. By considering ASDYM fields in  $(2+2)$ -dimensions invariant under a 1-dimensional group of translations, we can obtain solutions of the Bogomol'nyi equations in  $(2+1)$ -dimensional space-time. Again these solutions correspond to bundles over the holomorphic tangent bundle of the Riemann sphere (but the conditions which are needed to ensure real solutions are different).

The Bogomol'nyi equations make sense in curved space-times but in general are not integrable. However we shall show in this thesis that when the space-time has constant curvature the equations are indeed integrable. There are three standard space-times of constant curvature classified by whether the scalar curvature is zero, positive or negative. These are Minkowski space-time, which was mentioned earlier, deSitter space-time and anti-deSitter space-time respectively. The Bogomol'nyi equations can be obtained from the ASDYM equations by imposing symmetry under “rotations” in the case of deSitter space-time and “Lorentz boosts” in the case of anti-deSitter space-time. The solutions correspond to bundles over the reduced twistor space, which is  $\mathbb{C}\mathbb{P}^1 \times \mathbb{C}\mathbb{P}^1$ . This is analogous to the situation on Riemannian

3-manifolds. The Bogomol'nyi equations on hyperbolic 3-space, a space of constant curvature and negative scalar curvature, can be obtained by imposing rotational symmetry on ASDYM fields in Euclidean space.

We shall now review two of the main motivations for studying ASDYM equations, namely Yang-Mills theories and integrable systems.

## 1.1 Instantons and Monopoles

Before discussing the two classes of solutions of nonabelian gauge theory in which we are interested, namely Yang-Mills instantons and BPS monopoles, we shall outline the basics of gauge theories. There are a number of good references for gauge theories such as [1, 2, 3, 4]. We shall focus on classical gauge theories, the quantum theory is described in many references such as [5]. The role of solitons and instantons is described in [6]. There are a number of good reviews of monopoles including [7] and [8].

### Gauge Theories

Gauge theories are generalisations of Maxwell's theory of electromagnetism. The essential feature is that these theories are invariant *locally* under a Lie group of internal symmetries. In the case of Maxwell theory the Lie group is  $U(1)$ . Nonabelian gauge theories or Yang-Mills theories involve replacing  $U(1)$  with a nonabelian Lie group. Such theories are used to model not just electromagnetic forces but also the strong and weak nuclear forces. The theory is attractive mathematically — gauge theory is most naturally described by the language of differential geometry.

Let  $\mathbb{M}^{3+1}$  be  $(3 + 1)$ -dimensional Minkowski space-time. This is  $\mathbb{R}^4$  with coordinates  $(x_0, x_1, x_2, x_3)$  and metric

$$ds^2 = dx_0^2 - dx_1^2 - dx_2^2 - dx_3^2.$$

Let  $G$  be a Lie group with Lie algebra  $\mathfrak{g}$ . A gauge potential  $A = A_\mu dx^\mu$  is a 1-form taking values in the Lie algebra. The field strength corresponding to  $A$  is a  $\mathfrak{g}$ -valued

2-form  $F = \frac{1}{2}F_{\mu\nu}dx^\mu \wedge dx^\nu$ , where

$$F_{\mu\nu} = \partial_\mu A_\nu - \partial_\nu A_\mu + [A_\mu, A_\nu].$$

To define a Lagrangian one needs a Killing form, that is to say an inner product  $(\cdot, \cdot)$  on  $\mathfrak{g}$ . One then defines the Lagrangian of pure Yang-Mills theory to be

$$\mathcal{L} = -\frac{1}{4}(F_{\mu\nu}, F^{\mu\nu}).$$

If  $G$  is  $SU(N)$  then its Lie algebra consists of traceless skew-symmetric  $N \times N$  matrices and the Killing form is

$$(A, B) = -\frac{1}{2}\text{tr}(AB).$$

The Lagrangian is then

$$\mathcal{L} = \frac{1}{8}\text{tr}(F_{\mu\nu}, F^{\mu\nu}).$$

The action  $S$  is the integral of the Lagrangian and can be written in terms of forms as

$$S = \frac{1}{8} \int \text{tr}(F \wedge *F),$$

where  $*$  is the Hodge star

$$*F_{\mu\nu} = \frac{1}{2}\epsilon_{\mu\nu\alpha\beta}F^{\alpha\beta}.$$

If  $g$  is a  $G$ -valued function on  $M$ , one can consider the transformation

$$A_\mu \longrightarrow g^{-1}A_\mu g + g^{-1}\partial_\mu g, \tag{1.1}$$

under which the field strength transforms as

$$F_{\mu\nu} \longrightarrow g^{-1}F_{\mu\nu}g.$$

In particular, if  $F_{\mu\nu} = 0$  then  $A_\mu = g^{-1}\partial_\mu g$  for some  $g$ . Transformations of this kind are called gauge transformations and preserve the Lagrangian.

So far we have only considered pure gauge theory. To couple fields to the gauge field one uses the principle of minimal coupling. One considers a collection of fields, which must be representations of the gauge group, and replaces ordinary derivatives

$\partial_\mu$  in the Lagrangian with covariant derivatives  $D_\mu$ . For example, if a field  $\Phi$  is in the fundamental representation, i.e. is column vector-valued, then

$$D_\mu \Phi = \partial_\mu \Phi + A_\mu \Phi,$$

and if  $\Phi$  is in the adjoint representation, i.e. taking values in the Lie algebra of  $G$ , then

$$D_\mu \Phi = \partial_\mu \Phi + [A_\mu, \Phi].$$

Under gauge transformations (1.1),  $\Phi$  and its covariant derivative transform as

$$\begin{aligned} \Phi &\longrightarrow g^{-1}\Phi, \\ D_\mu \Phi &\longrightarrow g^{-1}D_\mu \Phi, \end{aligned}$$

for the fundamental representation and

$$\begin{aligned} \Phi &\longrightarrow g^{-1}\Phi g, \\ D_\mu \Phi &\longrightarrow g^{-1}D_\mu \Phi g, \end{aligned}$$

for the adjoint representation. The commutator  $[D_\mu, D_\nu]\Phi$  is  $F_{\mu\nu}\Phi$  for the fundamental representation, and  $[F_{\mu\nu}, \Phi]$  for the adjoint representation.

One example is QCD where one has an  $SU(3)$  gauge field and Dirac spinor fields in the fundamental representation coupled to it. Another example which will be important to us is a Yang-Mills-Higgs theory. One can consider a gauge field and a scalar field, a Higgs field, in the adjoint representation, with Lagrangian

$$\mathcal{L} = -\frac{1}{4}(F_{\mu\nu}, F^{\mu\nu}) + \frac{1}{2}(D_\mu \Phi, D^\mu \Phi) - V(\Phi)$$

for some function  $V$ .

A key feature of gauge theories is the possibility of spontaneous symmetry breaking. This occurs when the ground state or vacuum of the theory is degenerate. A given choice of ground state is not preserved by the full gauge group but by a subgroup  $H$  called the residual group. We say the gauge group  $G$  is broken to  $H$ . One then considers perturbations around this ground state. For example in the Weinberg-Salam model of electro-weak theory  $SU(2) \times U(1)$  is broken to  $U(1)$ . This

mechanism gives masses to some of the gauge particles, which would otherwise be massless since mass terms are not gauge invariant. In the Yang-Mills-Higgs theory above with gauge group  $SU(N)$  if the set of minima of  $V$  is degenerate and a ground state has eigenvalues  $\lambda_1, \dots, \lambda_r$  with degeneracies  $N_1, \dots, N_r$  then  $SU(N)$  is broken to  $SU(N_1) \times \dots \times SU(N_r) \times U(1)^{r-1}$ . This is of interest in Grand Unified Theories (GUTs), which are an attempt to unify the strong and electro-weak forces. An example is  $SU(5)$  gauge theory, which, when  $N_1 = 3$ ,  $N_2 = 2$ , is broken to  $SU(3) \times SU(2) \times U(1)$ .

Let us consider classical solutions of these theories, i.e. solutions of the Euler-Lagrange equations for critical points of the Lagrangian (of course one must consider the quantum theory to get any realistic understanding of the theory, but we shall not do this here). For pure Yang-Mills theory the Euler-Lagrange equations are

$$D*F = 0,$$

in other words,

$$D_\mu F^{\mu\nu} = 0,$$

where of course  $D*F \equiv d*F + [A, *F]$ ,  $D_\mu F \equiv \partial_\mu F + [A_\mu, F]$ . The gauge field automatically satisfies the Bianchi identity

$$DF = 0,$$

or in components,

$$D_\mu *F^{\mu\nu} = 0,$$

Thus if  $*F = \lambda F$  for a constant  $\lambda$ , then the Bianchi identity implies  $D*F = 0$ , and thus the Euler-Lagrange equations of the theory are satisfied. However for a two-form  $B$  on Minkowski space-time,  $**B = -B$ , and  $\lambda$  would have to be  $\pm i$ . So for real gauge groups, which include groups such as  $SU(N)$  in which we are particularly interested, there are no solutions except for the trivial case when  $F = 0$ . One way around this is to consider gauge fields on *Euclidean* space. We shall consider this possibility later.

For the Yang-Mills-Higgs theory above the Lagrangian gives Euler-Lagrange

equations

$$\begin{aligned} D_\mu D^\mu \Phi + \frac{\partial V}{\partial \Phi} &= 0, \\ D_\mu \Phi &= -[\Phi, D_\mu \Phi]. \end{aligned}$$

The objects discussed in the previous section — gauge potentials, field strength and so on — can be most naturally described in the language of differential geometry. The operator  $D_\mu$  defines a connection on a bundle  $E$  over  $M$  with curvature  $F$ . Fields coupled to the gauge field are sections of associated bundles over  $M$ . Gauge transformations correspond to bundle automorphisms, or locally to changes in the choice of trivialisations of the bundle. Alternatively, one can describe the theory in terms of principal bundles. The gauge potential  $A$  is the pullback of a connection 1-form on a principal bundle  $P$  over  $M$  under a section  $s$  of the bundle,  $F$  is the pullback of the curvature 2-form on  $P$ , a gauge transformation is a bundle automorphism or locally is equivalent to a choice of section  $s$ . Again the fields coupled to the gauge field are sections of associated bundles. When Minkowski space-time is replaced by a (general) 4-manifold these geometric and topological considerations become important.

## Yang-Mills Instantons

As was mentioned previously, for real gauge groups there are no non-trivial solutions of  $*F = \lambda F$  for Minkowski space-time. However for a 2-form  $B$  on Euclidean space  $\mathbb{E}^4$ ,  $**B = B$ . Thus if we define gauge theories on  $\mathbb{E}^4$ , then  $\lambda = \pm 1$ , and there is the possibility of non-trivial solutions. When  $*F = F$  the Yang-Mills field is said to be self-dual, and when  $*F = -F$ , anti-self-dual, and these equations are the self-dual and anti-self-dual Yang-Mills equations respectively. The extension of gauge theories from Minkowski space-time to Euclidean space is straightforward. One simply replaces the Minkowski metric with that of Euclidean space, using it in particular to raise and lower indices. It is also customary to define the Euclidean action density to be

$$\mathcal{L} = \frac{1}{4}(F_{\mu\nu}, F^{\mu\nu}) = -\frac{1}{8}\text{tr}(F_{\mu\nu}F^{\mu\nu})$$



so that it is positive definite. The Euclidean action is then

$$S = \frac{1}{4} \|F\|^2 \equiv \frac{1}{8} \int \text{tr}(F \wedge *F).$$

It is not entirely obvious what role such solutions should play in gauge theory, since they are, after all, solutions on Euclidean space  $\mathbb{E}^4$ . The reason is that in the QFT of Yang-Mills fields one is interested in functional integrals of the form

$$\int \mathcal{D}[A_\mu] e^{iS[A_\mu]} P(A_\mu),$$

where  $S$  is the action of the theory,  $P$  a polynomial in  $A_\mu$ ,  $\mathcal{D}[A_\mu]$  is a suitable measure and the integral is taken over a suitable space of fields. These integrals are not well-defined, however we can analytically continue to  $\mathbb{E}^4$ , the integrals becoming

$$\int \mathcal{D}[A_\mu] e^{-S[A_\mu]} P(A_\mu).$$

An example is in determining the true vacuum of Yang-Mills theory. The classical vacua of the theory occur when  $F_{\mu\nu} = 0$ , i.e. when  $A$  is a pure gauge  $g^{-1}\partial_\mu g$ . In quantising the theory we choose a gauge with  $A_0 = 0$  and assume  $g \rightarrow 1$  at infinity. Thus  $g$  extends to a map from  $S^3$  to the gauge group which we shall assume is  $SU(2)$ . Such maps are classified up to homotopy by  $\pi_3(S^3) \cong \mathbb{Z}$ . The integer  $N$  labelling the class is given by

$$\begin{aligned} N &= \frac{1}{24\pi^2} \int (g^{-1}dg)^3 \\ &= \frac{1}{24\pi^2} \int d^3x \epsilon_{ijk} \text{tr}(g^{-1}g_i)(g^{-1}g_j)(g^{-1}g_k). \end{aligned}$$

Around each homotopy sector one constructs a vacuum state  $|N\rangle$ . These states are not orthogonal and tunnelling takes place between states. This tunnelling amplitude between the  $N^-$  and  $N^+$  states is determined by the Euclidean function integral

$$\int \mathcal{D}[A_\mu] e^{-S[A_\mu]},$$

where the integral is taken over Euclidean gauge fields which tend to pure gauges in the  $N^\pm$  sectors as  $x_0$  tends to  $\pm\infty$ . The dominant contributions of such integrals will be provided by the critical points of the action, and in particular the local minima. These critical points are of course given by the Euler-Lagrange equations.

Uhlenbeck [9] showed that if we have a gauge potential on  $\mathbb{E}^4$  with finite action, then it extends to the 1-point compactification of  $\mathbb{E}^4$ , namely the 4-sphere  $S^4$ . In other words, there is bundle  $E$  over  $S^4$  and connection  $D$  which extends the connection on  $\mathbb{E}^4$ . Thus we are interested in connections on  $S^4$  which satisfy the Yang-Mills equations. Such solutions are called instantons. For simple gauge groups  $G$ , such as  $SU(N)$ , the bundles over  $S^4$  are classified by a topological invariant, the second Chern class  $c_2(E)$ , given by

$$\begin{aligned} c_2(E) &= \frac{1}{8\pi^2} \int_{S^4} \text{tr}(F \wedge F) \\ &= \frac{1}{8\pi^2} \int_{S^4} \text{tr}(F_{\mu\nu} * F^{\mu\nu}). \end{aligned}$$

The integer  $k = -c_2(E)$  is called the instanton number.

Recall that self-dual and anti-self-dual gauge-fields are critical points of the action. In fact they are local minima. If we split  $F$  into its self-dual and anti-self-dual parts, i.e.  $F = F^+ + F^-$  where  $F^\pm = \frac{1}{2}(F \pm *F)$ , then substituting into the expression for instanton number and action we have

$$8\pi^2 k = \|F^+\|^2 - \|F^-\|^2, \quad S = \frac{1}{4}(\|F^+\|^2 + \|F^-\|^2),$$

and thus the action is bounded below by  $8\pi^2|k|$  with equality when  $F$  is self-dual, for  $k \geq 0$ , and anti-self-dual, for  $k \leq 0$ . One can define the instanton number in terms of the gauge potential at infinity. The condition of finite action  $F_{\mu\nu} = 0$  on the 3-sphere  $S^3$  at infinity, so it is a pure gauge, i.e.  $A_\mu = g^{-1}\partial_\mu g$ . Maps from  $S^3$  to  $SU(N)$  are classified up to homotopy by  $\pi_3(SU(N))$ . In more geometric language, to define a connection on  $S^4$  one covers the 4-sphere with two ‘hemispherical’ coordinate patches whose intersection is a thickening of the equator  $S^3$  and defines gauge potentials on each patch. On the intersection the potentials differ by a gauge transformation whose homotopy class is again classified by  $\pi_3(SU(N))$ .

Now one can write (see [3, 4])

$$\begin{aligned} \text{tr}(F \wedge F) &= d(\text{tr}(A \wedge dA + \frac{2}{3}A^3)) \\ &= d(\text{tr}(A \wedge F - \frac{1}{3}A^3)). \end{aligned}$$

So on a 3-sphere at infinity  $A = g^{-1}dg$  and, using Stokes' theorem,

$$\frac{1}{8\pi^2} \int \text{tr}(F \wedge F) = -\frac{1}{24\pi^2} \int (g^{-1}dg)^3.$$

The right-hand-side is the Brouwer index for  $g$ , and this relates the two topological classifications. As an example, if  $g = |x|^{-1}(x_0 + x_j\sigma^j)$  then  $k = 1$ , and  $k = n$  if we replace  $g$  by  $g^n$ .

In the context of our discussion on tunnelling between vacua, one can take the 3-sphere to be a 'cylinder at infinity' consisting of 2 large 3-discs at  $x_0 = \pm\infty$  and the cylindrical surface joining them. If we choose a gauge in which  $A_0 = 0$  then the contribution from the walls of the cylinder to the expression for the Brouwer index is zero, and the contributions from the discs are  $N^+$  and  $-N^-$ . Thus instantons with instanton number  $N^+ - N^-$  connect the  $N^-$  and  $N^+$  sectors.

The best known class of solutions of the anti-self-dual Yang-Mills equations is obtained using the t'Hooft ansatz. If one defines a gauge potential

$$A_\mu = i\sigma_{\mu\nu}\partial^\nu \log(\phi),$$

where  $\phi$  is a solution of the Laplace equation on  $\mathbb{E}^4$  and  $\sigma_{\mu\nu}$  are  $2 \times 2$  complex matrices with  $\sigma_{\mu\nu} = -\sigma_{\nu\mu}$  and  $\sigma_{\mu\nu} = -*\sigma_{\mu\nu}$ , then  $A_\mu$  is self-dual. If we take

$$\phi = \sum_{\alpha=0}^k \frac{\lambda_\alpha}{|x - x_\alpha|^2}$$

or the limiting case when  $x_0$  is at infinity then we get a finite action self-dual field with instanton number  $k$ . If we replace  $\sigma_{\mu\nu}$  by self-dual matrices,  $\tilde{\sigma}_{\mu\nu} = *\tilde{\sigma}_{\mu\nu}$  then the field is anti-self-dual.

Not all solutions are of this form. The ansatz contains  $5k - 4$  parameters. However Atiyah, Hitchin and Singer showed that the set of instantons up to gauge equivalence, the moduli space, is a  $(8k - 3)$ -manifold [10].

## BPS Monopoles

One interesting class of solutions of nonabelian gauge theories is that of magnetic monopoles. These arise in Yang-Mills-Higgs gauge theory when the gauge group  $G$  is spontaneously broken to a residual gauge group  $H$ . As was mentioned this is relevant

in, for example, Grand Unified Theories. The solutions are classified topologically by  $\pi_2(G/H)$ . The simplest case is  $G = SU(2)$ , and we shall concentrate on this. Consider an  $SU(2)$ -gauge field with an adjoint Higgs,

$$\mathcal{L} = -\frac{1}{4}(F_{\mu\nu}, F^{\mu\nu}) + \frac{1}{2}(D_\mu\Phi, D^\mu\Phi) - \frac{1}{8}\lambda(1 - \|\Phi\|^2)^2.$$

This has a minimum energy solution  $A_\mu = 0$ ,  $\Phi = \Phi_0$  for a constant  $\Phi_0$  with  $\|\Phi\| = 1$ . Under a gauge transformation,  $\Phi_0 \longrightarrow g^{-1}\Phi_0g$  so is preserved by a  $U(1)$  subgroup of  $SU(2)$ , namely by those  $g$  of the form  $\exp(\chi\Phi)$  for a real number  $\chi$ . In other words,  $SU(2)$  is broken to  $U(1)$ . The residual symmetry group is identified with the gauge group of electromagnetism, and one can define electric and magnetic fields by

$$b_i = (B_i, \widehat{\Phi}), \quad e_i = (E_i, \widehat{\Phi}),$$

where  $\widehat{\Phi}$  is  $\Phi/\|\Phi\|$ ,  $E_i = F_{0i}$  and  $B_i = *F_{0i} = \frac{1}{2}\epsilon_{ijk}F^{ij}$ . We shall be interested in solutions which are static and purely magnetic, in other words,  $A_0 = 0$ , and  $\Phi$  and  $A_i$  are independent of the time coordinate  $x_0$ . The energy density is thus

$$\mathcal{H} = \frac{1}{4}(F_{ij}, F^{ij}) + \frac{1}{2}(D_i\Phi, D^i\Phi) + \frac{1}{8}\lambda(1 - \|\Phi\|^2)^2.$$

Finite energy implies  $\|\Phi\| \longrightarrow 1$  as  $|x| \longrightarrow \infty$ , and so we have a map from the 2-sphere at infinity to the unit 2-sphere in the Lie algebra of  $SU(2)$ . Topological solutions are classified up to homotopy by  $\pi_2(S^2) \cong \mathbb{Z}$ , in other words by an integer  $n$  which is the winding number or Brouwer degree of the map, which is given (see [11]) by

$$n = \frac{1}{8\pi} \int \text{tr}(B_i D^i \Phi) d^3x.$$

This  $n$ , in the context of monopoles, is called the topological charge or monopole number. Note since  $SU(2)$  acts transitively on the unit sphere  $S^2$  in  $\mathfrak{su}(2)$  with stabiliser  $U(1)$ , the sphere can be identified with the coset space  $SU(2)/U(1)$ , and, by a standard result of algebraic topology (see [5]),

$$\pi_2(SU(2) \times U(1)) \cong \pi_1(U(1)).$$

On the sphere at infinity  $b_i = \frac{1}{2}\text{tr}(B_i\Phi)$ . So one can compute the magnetic charge

$$\begin{aligned} Q &= \int_{S^2} b \\ &= \int_{\mathbb{E}^3} db \\ &= \frac{1}{2} \int_{\mathbb{E}^3} \text{tr}(B_i D^i \Phi) \\ &= 4\pi n. \end{aligned}$$

Thus the topological charge is proportional to the magnetic charge.

An argument due to Bogomol'nyi [12] allows us to estimate the energy of the configuration in terms of the topological charge. If we expand the inequality

$$-\text{tr}((B_i \pm D_i \Phi)(B^i \pm D^i \Phi)) \geq 0$$

and substitute into the energy, then we obtain

$$\mathcal{H} \geq \frac{1}{8} \lambda (1 - \|\Phi\|^2)^2 \pm \text{tr}(B_i D^i \Phi).$$

The energy satisfies

$$E \geq \int \frac{1}{8} \lambda (1 - \|\Phi\|^2)^2 d^3x \pm 8\pi n,$$

with equality if and only if  $B_i = \mp D_i \Phi$ .

Now let us consider solutions of the theory. 'tHooft and Polyakov constructed a spherically symmetric monopole of charge 1 in terms of radial profile functions by applying an existence theorem for ODEs. The solution cannot be expressed in terms of elementary functions for  $\lambda > 0$ . However Prasad and Sommerfield showed [13] that when  $\lambda = 0$  the gauge potential and Higgs field are given by

$$\begin{aligned} A_i &= -i\epsilon_{ijk}\sigma_j x_k \frac{\sinh r - r}{r^2 \sinh r}, \\ \Phi &= i\sigma_j x_j \frac{r \cosh r - \sinh r}{r^2 \sinh r}, \end{aligned}$$

where  $r$  is the radial distance in  $\mathbb{E}^3$ . From now on we shall concentrate on the limiting case with  $\lambda = 0$ , but retaining the boundary condition  $\|\Phi\| = 1$  at infinity, the Prasad-Sommerfield limit. In this case the energy estimate is saturated and so

such solutions are stable. The fields satisfy the Bogomol'nyi equations and such solutions are called Bogomol'nyi-Prasad-Sommerfield (BPS) monopoles.

The energy density can be calculated from the Higgs field alone, since the Bianchi identity  $D_i B^i = 0$  and the Bogomol'nyi equations imply

$$-\text{tr}((D_i \Phi)(D^i \Phi)) = \Delta \|\Phi\|^2,$$

where  $\Delta = \partial_i \partial^i$  is the Laplacian in  $\mathbb{E}^3$ , so that

$$\begin{aligned} n &= \frac{1}{8\pi} \int \text{tr}(B_i D^i \Phi) d^3x \\ &= \frac{1}{8\pi} \int \text{tr}(D_i \Phi D^i \Phi) d^3x \\ &= \frac{1}{8\pi} \int \Delta \|\Phi\|^2 d^3x, \end{aligned}$$

and thus  $\|\Phi\| = 1 - \frac{n}{r} + O(r^{-2})$  as  $r \rightarrow \infty$ .

The energy density of the t'Hooft-Polyakov monopole is localised around, and takes its maximum value at, the origin, and the Higgs field  $\Phi$  has a zero there. A general  $n$ -monopole solution has  $n$  zeros counted with multiplicities (see [11]), and one regards a zero of  $\Phi$  as the location of a monopole. The set of gauge equivalence classes of smooth, charge  $n$  solutions is a  $(4n - 1)$ -manifold  $M_n$  [14]. For the 1-monopole these 3 parameters are the position coordinates of the centre. The dimension of  $M_n$  is more obvious for  $n \geq 2$  if one considers the gauge transformations with  $g = \exp(\chi \Phi)$  for real  $\chi$ . If one takes  $\chi$  to vary linearly with time, then one obtains a dyon, a configuration with both electric and magnetic charges, and  $\chi$  can be thought of as a conjugate variable to electric charge. One should think of BPS  $n$ -monopoles as configurations of  $n$  1-monopoles, at least when the monopoles are widely separated. Each monopole is determined by 3 position coordinates and a phase. After removing a global phase we are left with  $4n - 1$  parameters.

For  $G = SU(N)$  one assumes  $\Phi$  is asymptotically in the gauge orbit of

$$i \text{diag}(\mu_1, \dots, \mu_N)$$

with  $\mu_1 \geq \mu_2 \geq \dots \geq \mu_N$  and  $\mu_1 + \mu_2 + \dots + \mu_N = 0$ . For distinct  $\mu_i$  (maximal symmetry breaking),  $H = U(1)^{N-1}$  and

$$\pi_2(SU(N)/U(1)^{N-1}) \cong \pi_2(U(1)^{N-1}) \cong \mathbb{Z}^{N-1}$$

Asymptotically the Higgs field is

$$\Phi = i\text{diag}(\mu_1, \dots, \mu_N) - \frac{i}{r}\text{diag}(n_1, \dots, n_N) + O(r^{-2}),$$

and the topological charges are  $n_1, n_1 + n_2, \dots, n_1 + \dots + n_{N-1}$ .

## 1.2 Integrable Systems

The ASDYM equations, as we mentioned earlier, are an example of an integrable system, by virtue of the twistor construction which we shall outline in Chapter 2. The equations in fact play an important role in the study of integrable systems since a great many equations can be obtained from the ASDYM equations by imposing symmetry and inherit the integrability of the original system as a result. As Ward puts it [15]

*“many of the ordinary and partial differential equations that are regarded as being integrable or soluble may be obtained from the [anti-]self-dual gauge field equations (or its generalisations) by reduction.”*

In general integrability is difficult to define, hence the phrase “regarded as being integrable”. The subject consists largely of examples and techniques which apply to them — techniques which do not always readily extend from one system to another.

For Hamiltonian systems of classical mechanics the notion of integrability is relatively straightforward. A  $2n$ -dimensional system is completely integrable if one can find functions  $F_1 \dots F_n$  which Poisson commute with the Hamiltonian of the system and each other and whose differentials are linearly independent. The level surfaces of these functions when compact are  $n$ -tori. If  $Q_1 \dots Q_n$  are angular coordinates on the tori then one can replace  $F_1 \dots F_n$  with functions  $P_1 \dots P_n$ , which again Poisson commute with the Hamiltonian and each other and have linearly independent differentials, such that  $\{Q_i, P_j\} = \delta_{ij}$ . With respect to these action-angle coordinates the equations of motion are

$$\frac{dP_i}{dt} = 0, \quad \frac{dQ_i}{dt} = \frac{\partial H}{\partial P_i} = \text{constant}.$$

The situation is more complicated in infinite dimensions. One can take a similar phase-space approach, which requires the imposition of boundary conditions. This is not so satisfactory since integrability should be a property of the equation and not depend on the boundary conditions. This approach also cannot be easily extended to elliptic equations or equations of other signatures. A number of properties are often possessed by integrable systems though. One has methods of constructing



solutions — often explicitly, there exist a large number of constants of motion - thus ruling out chaotic behaviour, one can find non-linear superpositions of solutions, and there are also properties such as the Painlevé property [1, 16].

A classic example is the KdV  $u_t = 6uu_x + u_{xxx}$ , which displays most of these properties. There are a number of techniques for solving the KdV, the most notable being the inverse scattering transform. In this approach one imposes the boundary condition  $u \rightarrow 0$  rapidly as  $x \rightarrow \pm\infty$  and considers eigenvalues  $v$  of the operator  $L = \partial_{xx} + u$  with eigenvalues  $\lambda$  for each value of  $t$ . If the  $t$ -evolution of the eigenfunctions is given by  $v_t = Mv$ , where  $M = (\gamma + u_x)v + (4\lambda + 2u)v_x$  for some real  $\gamma$ , then this is compatible with the eigenvalue equation if and only if  $u$  satisfies the KdV. The set of eigenvalues together with certain information obtained from the asymptotic behaviour of the eigenfunctions is called the scattering data. One finds the scattering data at  $t = 0$  for the initial condition  $u(x, 0) = f(x)$ , using the  $t$ -evolution equation to find the scattering data at time  $t$  and recover  $u(x, t)$  for the scattering data — the inverse scattering problem. This last problem is equivalent to solving a Riemann-Hilbert problem (see [16]), which is related to the splitting of the patching matrix in the twistor transform which we shall discuss in Chapter 2. If one has functions  $X$  and  $T$  of  $x, t$  and  $u$  and its derivatives satisfying  $D_t X + D_x T = 0$ , where  $D$  denotes a total derivative, then if  $X(x, t, u, \dots)$  disappears sufficiently rapidly then

$$\int_{-\infty}^{\infty} T(x, t, u, \dots) dx$$

is constant. The KdV possesses an infinite number of such conservation laws, see [16]. One can write the KdV as a Hamiltonian system and can define action-angle variables in terms of the scattering data. There are soliton solutions which correspond to discrete eigenvalues of  $L$ , and one can find nonlinear superpositions of solutions by considering scattering data with  $n$  discrete eigenvalues. These solutions pass through each other, although there is a time shift.

The inverse scattering transform can be generalised to other systems such as the sine-Gordon (SG) and nonlinear Schrödinger (NLS) equations. Lax showed that a scattering problem  $Lv = \lambda v$  and a time evolution equation  $v_t = Mv$  are compatible if and only if  $L_t + [L, M] = 0$ . Such a pair of linear operators is called

a Lax pair. Most integrable systems are solved by writing them as compatibility conditions for a system of linear equations, although they may be more general systems than those considered by Lax. The KdV can be obtained from the ASDYM by reduction (although the Lax pair above is different from that obtained from the ASDYM equations) as can the SG, NLS, the Minkowski space-time Bogomol'nyi equations and the integrable chiral equation. These last two related systems have a Lax pair which we shall describe in Section 3.1. One approach to this system uses the 'Riemann method with zeros' to generate solutions of the linear system rather than the inverse scattering transform. These systems have soliton solutions which can be superposed to obtain multi-soliton solutions which pass through each other and solutions which exhibit  $90^\circ$  scattering. There is a conserved 'energy' density in the case of the integrable chiral model as well as an infinite number of conservation laws.

# Chapter 2

## Twistors and the ASDYM Equations

In this chapter we shall describe the solutions of the ASDYM equations, and their reductions, by the twistor transform. Twistors were first introduced by Roger Penrose in his paper “Twistor Algebra” [17]. The aim of the twistor programme was to describe the equations of mathematical physics using objects called twistors. In this approach the twistors are the fundamental objects of the theory and the space-time points, which are usually regarded as fundamental, are derived from them. There is an extensive literature from this viewpoint (see for example [18]). From the viewpoint of this thesis we shall concentrate on the role of twistors in the ASDYM equations and integrable systems. The references closest to this point of view are [1] and [2]. The ASDYM equations are best described in terms of connections on vector or principal bundles and these are described in the appendix.

### 2.1 The ASDYM Equations

Let  $D$  be connection on a vector bundle  $E$  over a smooth manifold  $M$  with metric  $g$  of Riemannian, Lorentzian or ultrahyperbolic  $(++--)$  signature.  $D$  is *self-dual*

(SD) if its curvature  $F$  satisfies  $F = *F$  and *anti-self-dual* (ASD) if

$$F = -*F,$$

where  $*$  is the Hodge star.

We shall mostly be concerned with connections on manifolds covered by a single chart, in which case  $D = d + A$  for a  $\mathfrak{gl}(k, \mathbb{C})$ -valued 1-form. In any case,  $D$  is locally of this form. Given a Lie group  $G$ , the gauge group, with Lie algebra  $\mathfrak{g}$ , we can consider connections such that  $A$  is  $\mathfrak{g}$ -valued. For example, if  $D$  is compatible with an Hermitian structure on  $E$  then we can take  $G = U(k)$ . The curvature  $F$  is a  $\mathfrak{g}$ -valued 2-form with

$$F_{\mu\nu} = \partial_\mu A_\nu - \partial_\nu A_\mu + [A_\mu, A_\nu].$$

The connection is ASD if  $D$  satisfies the anti-self-dual Yang-Mills equations

$$*F_{\mu\nu} \equiv \frac{1}{2} \Delta \epsilon_{\mu\nu\alpha\beta} F^{\alpha\beta} = -F_{\mu\nu},$$

where  $\Delta = \det(g_{\mu\nu})^{1/2}$ . The ASDYM equations are conformally invariant with conformal weight zero. This means means that they have the property that if we replace the metric  $g_{\mu\nu}$  with  $\Omega^2 g_{\mu\nu}$  for some positive function  $\Omega$ , then a connection which is ASD with respect to the first metric is also ASD with respect to the second.

If we consider  $\mathbb{R}^4$  there are 3 standard signature cases, namely Euclidean space, Minkowski space-time and ultrahyperbolic space-time. In Euclidean space  $\mathbb{E}^4$ , with metric  $ds^2 = (dx^1)^2 + (dx^2)^2 + (dx^3)^2 + (dx^4)^2$ , the equations are

$$F_{12} = -F_{34}, \quad F_{13} = -F_{42}, \quad F_{14} = -F_{23}.$$

In Minkowski space-time, with metric  $ds^2 = -(dx^0)^2 + (dx^1)^2 + (dx^2)^2 + (dx^3)^2$ , the equations are

$$F_{01} = -iF_{23}, \quad F_{02} = -iF_{31}, \quad F_{03} = -iF_{12}.$$

For ultrahyperbolic space-time, with metric  $ds^2 = (dx^1)^2 + (dx^2)^2 - (dx^3)^2 - (dx^4)^2$ , the equations are

$$F_{12} = -F_{34}, \quad F_{13} = +F_{42}, \quad F_{14} = -F_{23}.$$

Clearly, if  $G$  is a real group such as  $SU(2)$ , then there are no solutions in the case of Minkowski space-time, except the trivial solution  $F = 0$ .

It will be convenient to consider ASD connections on complex space-times. This allows us to handle the various signature space-times in a unified way and brings out the analytic and geometric structure of the equations. In particular we shall be interested in complexified Minkowski space-time  $\mathbb{CM}$ . This is the complex manifold  $\mathbb{C}^4$  with coordinates  $w, z, \tilde{w}$  and  $\tilde{z}$  (called double-null coordinates), metric  $ds^2 = dzd\tilde{z} - dwd\tilde{w}$  and volume form  $\nu = \frac{1}{4}dw \wedge d\tilde{w} \wedge dz \wedge d\tilde{z}$ . The various signature space-times (Euclidean, Minkowski and ultrahyperbolic) are all embedded in  $\mathbb{CM}$  as 4-dimensional real slices (in other words copies of  $\mathbb{R}^4$ ). One recovers Euclidean space as the real slice  $\tilde{w} = -\bar{w}, \tilde{z} = \bar{z}$ . If one defines coordinates  $x^1, \dots, x^4$  by

$$\begin{pmatrix} \tilde{z} & w \\ \tilde{w} & z \end{pmatrix} = \begin{pmatrix} x^1 + ix^2 & -x^3 + ix^4 \\ x^3 + ix^4 & x^1 - ix^2 \end{pmatrix},$$

then  $ds^2$  is the Euclidean metric on the real slice. Similarly if we define coordinates by

$$\begin{pmatrix} \tilde{z} & w \\ \tilde{w} & z \end{pmatrix} = \begin{pmatrix} x^0 + x^1 & x^2 - ix^4 \\ x^2 + ix^3 & x^0 - x^1 \end{pmatrix},$$

the metric is that of Minkowski space-time. For the ultrahyperbolic case there are two possible slices. The first,  $\mathbb{U}_1$ , is obtained by taking  $w, \tilde{w}, z$  and  $\tilde{z}$  real. The other  $\mathbb{U}_2$  is the real slice  $\tilde{w} = \bar{w}, \tilde{z} = \bar{z}$ .

In double-null coordinates the ASDYM equations become

$$F_{wz} = 0, \quad F_{w\tilde{w}} - F_{z\tilde{z}} = 0, \quad F_{\tilde{w}\tilde{z}} = 0.$$

The advantage of double-null coordinates is that in these coordinates the Lax pair for the equations takes a relatively simple form. The Lax pair is the basis for the twistor methods which we describe in the next section.

## 2.2 Twistor Methods

### Lax Pairs

The ASDYM equations are equivalent to  $[L, M] = 0$ , where

$$L = D_w - \zeta D_{\tilde{z}}, \quad M = D_z - \zeta D_{\tilde{w}}.$$

This is the compatibility condition for the over-determined linear system

$$Ls = 0, \quad Ms = 0$$

to have a solution for each value of  $\zeta$ . If  $l$  and  $m$  are respectively the vectors  $\partial_w - \zeta \partial_{\tilde{z}}$ ,  $\partial_z - \zeta \partial_{\tilde{w}}$  in  $\mathbb{CM}$  then the compatibility condition is equivalent to  $F(l, m) = 0$ . If one replaces  $l$  and  $m$  by linear combinations  $l'$ ,  $m'$  of  $l$  and  $m$  then  $F(l', m')$  is still zero (but  $L' = D_{l'}$  and  $M' = D_{m'}$  only commute modulo linear combinations of  $L'$  and  $M'$ ). Thus the equations are a statement about a certain family of planes, namely that the restriction of the curvature to the planes spanned by the vectors  $l$  and  $m$  is zero.

Let us consider these planes in more detail. A 2-plane in  $\mathbb{CM}$  is totally null if for all vectors  $X, Y$  in the plane  $g(X, Y) = 0$ . Given vectors spanning a plane  $\pi = X \wedge Y$  is determined up to a scalar multiple by the plane. If the plane is null then  $*\pi_{\mu\nu} = \pm\pi_{\mu\nu}$ . (This is because  $\pi$  is determined up to scalar multiple by the condition  $\pi_{\mu\nu}X^\mu = 0$  for all vectors  $X$  in the plane. However for null planes  $\pi_{\mu\nu}X^\mu = 0$  and thus  $\pi_{\mu\nu} = \lambda\pi_{\mu\nu}$ . Since  $** = 1$ ,  $\lambda = \pm 1$ .) This divides null 2-planes into 2 families of planes — self-dual or  $\alpha$ -planes for which  $\pi_{\mu\nu} = *\pi_{\mu\nu}$  and anti-self-dual or beta-planes for which  $\pi_{\mu\nu} = -*\pi_{\mu\nu}$ . Connections are ASD if the curvature vanishes on  $\alpha$ -planes (and SD if it vanishes on  $\beta$ -planes).

Self-dual planes through a given point form a 1-parameter family, parameterised by  $\zeta$ . In fact the set of  $\alpha$ -planes through a given point is a Riemann sphere. The quantities

$$\lambda = \zeta w + \tilde{z}, \quad \mu = \zeta z + \tilde{w}$$

are annihilated by  $l$  and  $m$  and so are constant on an  $\alpha$ -plane with parameter  $\zeta$ . Since an  $\alpha$ -plane  $Z$  is of codimension-2,  $\lambda$  and  $\mu$  together with  $\zeta$  determine  $Z$  and

the set of  $\alpha$ -planes is a (complex) 3-manifold  $\mathcal{P}$  with local coordinates  $\lambda$ ,  $\mu$  and  $\zeta$ . The set of pairs of points  $x$  in  $\mathbb{CM}$  and  $\alpha$ -planes  $Z$  through them is a 5-manifold  $\mathcal{F}$  with coordinates  $w$ ,  $\tilde{w}$ ,  $z$ ,  $\tilde{z}$  and  $\zeta$ . There is an obvious projection map from  $\mathcal{F}$  to  $\mathbb{CM}$  taking a typical point  $(x, Z)$  in  $\mathcal{F}$  to the point  $x$  and in local coordinates  $(w, \tilde{w}, z, \tilde{z}, \zeta)$  which is obtained by ignoring the  $\zeta$  coordinate. The compatibility condition means that if we pullback the bundle  $E$  and connection  $D$  to  $\mathcal{F}$  then there are local sections  $s$  of the pullback bundle  $E''$  such that  $D_l s = 0$  and  $D_m s = 0$ , where here by  $l$  and  $m$  we mean the lifts to  $\mathcal{F}$  of  $l$  and  $m$  assuming the  $\partial_\zeta$  component is zero. We can put together  $n$  linearly independent solutions to obtain a matrix-valued function  $f$  called a fundamental solution which satisfies  $D_l f = 0$ ,  $D_m f = 0$ . The solution can be made to vary holomorphically on  $\zeta$ , but cannot be extended to a regular function on the Riemann sphere including the point at infinity (except for trivial solutions). We can also find a solution  $\tilde{f}$  which is regular at  $\zeta = \infty$  but again cannot be extended to a regular function across the whole Riemann sphere. Given such a function  $f$  we can recover the gauge potential since

$$A_w - \zeta A_z = -l(f)f^{-1}, \quad A_z - \zeta A_{\tilde{w}} = -m(f)f^{-1}.$$

The equation  $F_{\tilde{w}\tilde{z}} = 0$  implies that a gauge may be chosen so that  $A_z$  and  $A_{\tilde{w}}$  are zero. Then putting  $A_w = A$   $A_z = B$  the Lax pair becomes

$$L = \partial_w - \zeta \partial_z + A, \quad M = \partial_w - \zeta \partial_{\tilde{w}} + B.$$

### J-matrix

Another way of approaching the ASDYM equations is through the  $J$ -matrix. Again the equation  $F_{\tilde{w}\tilde{z}} = 0$  implies we can find a matrix-valued function  $\tilde{h}$  of the space-time coordinates such that

$$D_{\tilde{w}} \tilde{h} = 0, \quad D_{\tilde{z}} \tilde{h} = 0.$$

Similarly the condition  $F_{wz} = 0$  implies the existence of another function  $h$  such that

$$D_w h = 0, \quad D_z h = 0$$

Then if we define  $J = \tilde{h}^{-1}h$  then the remaining self-duality equation, namely  $F_{w\tilde{w}} - F_{z\tilde{z}} = 0$ , is equivalent to the J-matrix equation

$$\partial_w(J^{-1}\partial_{\tilde{w}}J) - \partial_z(J^{-1}\partial_{\tilde{z}}J) = 0.$$

## Twistor Methods

In this section we shall outline the Ward transform which relates solutions of the ASDYM equations to holomorphic vector bundles over twistor space. This material can be found in a number of books and papers — the references [2] and especially [1] are closest to the approach taken here.

First we need to expand further on our description of the geometry of twistor space introduced earlier in this section. An  $\alpha$ -plane through point with coordinates  $w, z, \tilde{w}$  and  $\tilde{z}$  of  $\mathbb{CM}$  is spanned by vectors

$$l = Z^0\partial_w - Z^1\partial_{\tilde{z}}, \quad m = Z^0\partial_z - Z^1\partial_{\tilde{w}},$$

where  $(Z^0, Z^1)$  is a pair of complex numbers, not both zero. For a non-zero complex number  $c$ ,  $(cZ^0, cZ^1)$  and  $(Z^0, Z^1)$  determine the same  $\alpha$ -plane and so the set of  $\alpha$ -planes through a given point is a Riemann sphere with homogeneous coordinates  $Z^0, Z^1$  and inhomogeneous coordinate  $\zeta = Z^1/Z^0$  (the spectral parameter) taking values in  $\mathbb{C} \cup \{\infty\}$ . The quantities

$$Z^2 = wZ^1 + \tilde{z}Z^0, \quad Z^3 = zZ^1 + \tilde{w}Z^0 \tag{2.1}$$

are constant on a given  $\alpha$ -plane and the set of quadruples  $Z^\alpha = (Z^0, Z^1, Z^2, Z^3)$  forms a 4-dimensional complex vector space  $\mathbb{T}$ , which we call the twistor vector space. The quadruple  $Z^\alpha$  determines the  $\alpha$ -plane and an  $\alpha$ -plane in  $\mathbb{CM}$  determines a vector  $Z^\alpha$  in  $\mathbb{T}$ , with  $Z^0, Z^1$  not both zero, up to a non-zero complex multiple. Thus  $\alpha$ -planes are in 1-1 correspondence with the points of the region of the projective space  $P(\mathbb{T})$  with the projective line  $Z^0 = Z^1 = 0$  removed. We call this the twistor space,  $\mathcal{P}$ , of  $\mathbb{CM}$ . On the region  $\zeta \neq \infty$  we can take inhomogeneous coordinates

$$\lambda = Z^2/Z^0, \quad \mu = Z^3/Z^0, \quad \zeta = Z^1/Z^0,$$

and for  $\zeta \neq 0$  we can take inhomogeneous coordinates

$$\tilde{\lambda} = Z^2/Z^1, \quad \tilde{\mu} = Z^3/Z^1, \quad \tilde{\zeta} = Z^0/Z^1.$$



By fixing  $(Z^0, Z^1)$ , (2.1) shows how  $\alpha$ -planes correspond to 1-dimensional subspaces of  $\mathbb{T}$ . Alternatively, fixing  $w, z, \tilde{w}$  and  $\tilde{z}$  shows that points of  $\mathbb{CM}$  correspond to 2-dimensional subspaces of  $\mathbb{T}$ , i.e. projective lines in  $P(\mathbb{T})$ . This is the twistor correspondence —  $\alpha$ -planes in  $\mathbb{CM}$  correspond to points in  $P(\mathbb{T})$  and points in  $\mathbb{CM}$  correspond to lines in  $P(\mathbb{T})$ . This correspondence can be made exact by taking the conformal compactification  $\mathbb{CM}^\#$  of  $\mathbb{CM}$ . This is the the set of lines in  $P(\mathbb{T})$  or put another way, the Grassmannian  $\text{Gr}(\mathbb{T})$  of 2-dimensional subspaces of  $\mathbb{T}$ . Each line in  $P(\mathbb{T})$  corresponds to an  $\alpha$ -plane in  $\mathbb{CM}^\#$ .

Given an  $\alpha$ -plane  $Z$  through a point  $x$ , we have a 2-dimensional subspace  $S_2$  of  $\mathbb{T}$  corresponding to  $x$  and a 1-dimensional subspace  $S_1$  of  $S_2$  corresponding to  $Z$ . The set of such pairs  $(S_1, S_2)$  is an example of a flag manifold and is denoted  $F_{12}(\mathbb{T})$ . Thus the set of points and  $\alpha$ -planes through them, called the correspondence space, is just  $F_{12}(\mathbb{T})$  and the correspondence space is a 5-manifold with local coordinates  $w, z, \tilde{w}, \tilde{z}$  and  $\zeta$ .

Now consider an open subset  $U$  of  $\mathbb{CM}$ . We define the twistor space  $\mathcal{P} = \hat{U}$  of  $U$  to be the subset of  $P(\mathbb{T})$  corresponding to  $\alpha$ -planes which meet  $U$  and the correspondence space  $\mathcal{F} = \tilde{U}$  to be the set of pairs of points in  $U$  and  $\alpha$ -planes through them. We have the double fibration:

$$\begin{array}{ccc} & \hat{U} & \\ \mu \swarrow & & \searrow \nu \\ \hat{U} & & U \end{array}$$

where  $\mu(x, Z) = Z$  and  $\nu(x, Z) = x$ . Given a subset  $S$  of  $\mathbb{CM}^\#$ , we will denote  $\nu^{-1}(S)$  by  $\tilde{S}$  and  $\mu(\nu^{-1}(S))$  by  $\hat{S}$  and given a subset  $T$  of  $P(\mathbb{T})$  we will denote  $\nu(\mu^{-1}(T))$  by  $\tilde{T}$ . Note that for  $Z \in P(\mathbb{T})$ ,  $\tilde{Z}$  is an  $\alpha$ -plane and for  $x \in \mathbb{CM}$   $\hat{x}$  is a projective line (i.e. Riemann sphere) in  $P(\mathbb{T})$ .

Now we shall outline the correspondence due to Ward [19] between ASDYM fields and holomorphic vector bundles over twistor space. Suppose  $U$  is an open subset of  $\mathbb{CM}$  with the property that for each  $\alpha$ -plane  $Z$  meeting  $U$ , the intersection of  $U$  and  $Z$  is simply connected. Then we have the following

**Theorem 2.1** *There is a 1-1 correspondence between:*

a) *ASDYM fields with gauge group  $GL(n, \mathbb{C})$  on  $U$  (modulo gauge equivalence)*

*and*

b) *Rank- $n$  holomorphic vector bundles over  $\mathcal{P}$  whose restriction to  $\hat{x}$  is trivial for all  $x$  in  $U$ .*

The proof is as follows. Suppose we are given an ASDYM field on  $U$ , i.e. suppose we have a bundle  $E$  over  $U$  and covariant derivative  $D$  such that the curvature 2-form vanishes when restricted to  $\alpha$ -planes. Then for any  $Z \in \mathcal{P}$  the set of covariantly constant sections of  $E|_{\tilde{Z} \cap U}$ , which we call  $E'_Z$ , is a complex  $n$ -dimensional vector space. For if  $x_0 \in \tilde{Z} \cap U$  and  $s_0 \in E_{x_0}$  then there is a unique covariantly constant section  $s$  with  $s(x_0) = s_0$  given by the formal solution

$$s(x) = \mathbf{P} \exp\left(- \int_{\gamma} A_{\mu} dx^{\mu}\right) s_0,$$

where  $\gamma$  is a curve in  $\tilde{Z} \cap U$  joining  $x_0$  to  $x$  and  $\mathbf{P}$  denotes path ordering. This definition is independent of the choice of  $\gamma$ , as can be seen by using the simple-connectedness of  $\tilde{Z} \cap U$  together with the zero-curvature condition. Choosing  $n$  linearly-independent vectors in  $E_{x_0}$  gives  $n$  covariant constant sections through them which form a basis for  $E'_Z$ . This procedure is holomorphic and thus gives a rank- $n$  holomorphic vector bundle over  $\mathcal{P}$ . Given a point  $x \in U$ , we can take  $n$  linearly independent vectors in  $E_x$ . For each  $Z \in \mathcal{P}$  meeting  $x$ , we can define  $n$  covariantly constant sections, i.e. elements of  $E'_Z$ , one through each vector in  $E_x$ . By varying  $Z \in \hat{x}$  this gives  $n$  linearly independent sections of  $E|_{\hat{x}}$  and thus it is trivial. When  $U$  is  $\mathbb{CM}$ ,  $\mathcal{P}$  is covered by two charts,  $W$  and  $\tilde{W}$ , corresponding to  $\zeta \neq \infty$  and  $\zeta \neq 0$  respectively, over which  $E'$  is trivial. A holomorphic bundle over  $\mathcal{P}$  is determined by a holomorphic patching matrix  $F(Z)$  on  $W \cap \tilde{W}$ . If  $\xi, \tilde{\xi}$  are sections of the trivial bundles  $E_W, E_{\tilde{W}}$  then the patching matrix is defined by

$$\tilde{\xi} = F(Z)\xi.$$

If  $P$  and  $Q$  are the  $\alpha$ -planes with homogeneous coordinates  $Z^{\alpha} = (0, 1, 0, 0)$ ,  $Z^{\alpha} = (1, 0, 0, 0)$  respectively, then any  $Z \in W \cap \tilde{W}$  meets  $P$  in a single point  $x_P \in \mathbb{CM}$

and meets  $Q$  in another point  $x_Q \in \mathbb{CM}$ . Then the patching matrix is given by

$$F(Z) = \mathbf{P} \exp\left(-\int_{\gamma} A_{\mu} dx^{\mu}\right),$$

where  $\gamma$  joins  $x_P$  to  $x_Q$  in  $\tilde{Z} \cap \mathbb{CM}$ . If  $x \in \mathbb{CM}$  and we define

$$H(\zeta) = \mathbf{P} \exp\left(-\int_{x_P}^x A_{\mu} dx^{\mu}\right), \quad \tilde{H}(\zeta) = \mathbf{P} \exp\left(-\int_{x_Q}^x A_{\mu} dx^{\mu}\right),$$

where the integration is taken along  $\gamma$ , then  $H$  is holomorphic for  $\zeta \neq \infty$  and  $\tilde{H}$  for  $\zeta \neq 0$ , and we have

$$F(\mu(x, Z)) = \tilde{H}(\zeta)H(\zeta)^{-1}.$$

This ‘splitting’ of  $F(\mu(x, Z))$  into functions of the spectral parameter holomorphic for  $\zeta \neq \infty$  and  $\zeta \neq 0$  implies  $E'|_{\hat{x}}$  is trivial.

Conversely suppose we are given a holomorphic vector bundle  $E'$  such that  $E'|_{\hat{x}}$  is trivial for all  $x \in U$ . We could show how this gives a ASD gauge field abstractly but instead we assume  $\mathcal{P}$  is covered by two charts  $W, \tilde{W}$  over which  $E'$  is trivial and such that  $\zeta \neq \infty$  on  $W$  and  $\zeta \neq 0$  on  $\tilde{W}$ . This assumption is valid for the cases we shall be interested in. Then for each  $x \in U$  we can find a splitting

$$F(\mu(x, Z)) = \tilde{H}(\zeta)H(\zeta)^{-1},$$

and  $H, \tilde{H}$  can be chosen to vary holomorphically with  $x$ . Since  $F$  is a function on twistor space, we have

$$H^{-1}l(H) = \tilde{H}^{-1}l(\tilde{H}) \tag{2.2}$$

where  $l = \partial_w - \zeta \partial_{\tilde{z}}$  is one of the vectors  $l, m$  which span the  $\alpha$ -plane with spectral parameter  $\zeta$  and a similar formula holds for  $m$ . Since  $H$  is holomorphic for  $\zeta \neq \infty$  and  $\tilde{H}$ , for  $\zeta \neq 0$ , a Liouville-type argument shows that the quantity in (2.2) is of the form

$$A_w - \zeta A_{\tilde{z}},$$

for functions  $A_w, A_{\tilde{z}}$  of  $w, x, \tilde{w}$  and  $\tilde{z}$  but crucially not  $\zeta$ , and a similar argument applied to  $m$  gives us functions  $A_z$  and  $A_{\tilde{w}}$ . This defines a gauge potential  $A$  on  $U$ . If we apply the operator  $l$  to the expression for  $A_m = A_z - \zeta A_{\tilde{w}}$  and the operator

$m$  to the expression for  $A_l = A_w - \zeta A_{\bar{z}}$ , we find  $l(A_m) - m(A_l) = -[A_l, A_m]$  and so  $D = d + A$  is anti-self-dual.

It is easy to see that the construction of bundles from gauge fields and of gauge fields from bundles are mutual inverses and this completes the proof. This argument extends easily to the gauge group  $SL(n, \mathbb{C})$  where now the bundles have the extra property that the bundle  $\det E'$  whose transition functions are the determinants of the transition functions of  $E'$  is trivial. In terms of transition matrices this implies we can take transition matrices with unit determinant.

Now we shall consider how to reduce the gauge group from  $GL(n, \mathbb{C})$  (or  $SL(n, \mathbb{C})$ ) to  $U(2)$  (or  $SU(2)$ ) on the real slices. First we need the definition of a real structure on  $\mathbb{C}\mathbb{M}$ . A real structure  $\sigma$  is an anti-holomorphic involution on  $\mathbb{C}\mathbb{M}$ , i.e. a map  $\sigma : \mathbb{C}\mathbb{M} \rightarrow \mathbb{C}\mathbb{M}$  with  $\sigma^2 = 1$ ). Consider the following four real structures:

$$\begin{aligned}\sigma_1(w, z, \tilde{w}, \tilde{z}) &= (-\bar{\tilde{w}}, \bar{\tilde{z}}, -\bar{w}, \bar{z}), \\ \sigma_2(w, z, \tilde{w}, \tilde{z}) &= (\bar{\tilde{w}}, \bar{\tilde{z}}, \bar{w}, \bar{z}), \\ \sigma_3(w, z, \tilde{w}, \tilde{z}) &= (\bar{w}, \bar{z}, \bar{\tilde{w}}, \bar{\tilde{z}}), \\ \sigma_4(w, z, \tilde{w}, \tilde{z}) &= (\bar{\tilde{w}}, \bar{\tilde{z}}, \bar{w}, \bar{z}).\end{aligned}$$

The fixed point set of each of these real structures is a real slice, i.e. a copy of  $\mathbb{R}^4$  embedded in  $\mathbb{C}\mathbb{M}$ . For  $\sigma_1$ , the fixed point set is 4-dimensional Euclidean space, for  $\sigma_2$  it is Minkowski space and for  $\sigma_3$  and  $\sigma_4$  it is the two versions of ultrahyperbolic space introduced earlier in this section. A real structure clearly maps null 2-planes to null 2-planes. In the second example  $\sigma_2$  maps  $\alpha$ -planes to  $\beta$ -planes, but in the other cases the real structure takes  $\alpha$ -planes to  $\alpha$ -planes and  $\beta$ -planes to  $\beta$ -planes. Thus  $\sigma_1$ ,  $\sigma_2$  and  $\sigma_4$  give rise to anti-holomorphic involutions on the twistor space  $\mathcal{P} = \mathbb{C}\mathbb{P}^3 - \mathbb{C}\mathbb{P}^1$  which extend in an obvious way to the whole of  $P(\mathbb{T})$ . They are given by

$$\begin{aligned}\sigma_1(Z^\alpha) &= (\bar{Z}^1, -\bar{Z}^0, \bar{Z}^3, -\bar{Z}^2), & \sigma_1(\lambda, \mu, \zeta) &= (\bar{\zeta}^{-1}\bar{\mu}, \bar{\zeta}^{-1}\bar{\lambda}, -\bar{\zeta}^{-1}), \\ \sigma_3(Z^\alpha) &= (\bar{Z}^0, \bar{Z}^1, \bar{Z}^2, \bar{Z}^3), & \sigma_3(\lambda, \mu, \zeta) &= (\bar{\lambda}, \bar{\mu}, \bar{\zeta}), \\ \sigma_4(Z^\alpha) &= (\bar{Z}^1, \bar{Z}^0, \bar{Z}^3, \bar{Z}^2), & \sigma_4(\lambda, \mu, \zeta) &= (\bar{\zeta}^{-1}\bar{\mu}, \bar{\zeta}^{-1}\bar{\lambda}, \bar{\zeta}^{-1}).\end{aligned}$$

In the Euclidean and ultrahyperbolic cases, the condition that the gauge group

reduces from  $SL(2, \mathbb{C})$  to  $SU(2)$  is that there be an anti-holomorphic map  $\tau : E' \longrightarrow E'^*$ , where  $E'^*$  is the dual bundle of  $E'$ , such that the following diagram commutes:

$$\begin{array}{ccc} E' & \xrightarrow{\tau} & E'^* \\ \downarrow & & \downarrow \\ \mathcal{P} & \xrightarrow{\sigma} & \mathcal{P} \end{array}$$

(see [2, 1] for example). The condition that  $E|_{\hat{x}}$  is trivial need only hold for real space-time points.

Now we shall see what conditions we must put on the transition matrices of the bundle to obtain such a  $\tau$ . If we take  $\sigma = \sigma_1$  we can cover  $\mathcal{P}$  by charts which are interchanged by  $\sigma$ . The charts  $W, \tilde{W}$  with coordinates  $(\lambda, \mu, \zeta)$  and  $(\tilde{\lambda}, \tilde{\mu}, \tilde{\zeta})$  have this property. Over  $W$ , the bundles  $E'$  and  $E'^*$  are trivial and we can represent points of the bundles by pairs  $(Z, \xi), (Z, \mu)$ , respectively, where  $\xi$  is a column vector and  $\mu$  is row vector. Similarly we can represent points of  $E'|_{\tilde{W}}$  and  $E'^*|_{\tilde{W}}$  by pairs  $(Z, \tilde{\xi}), (Z, \tilde{\mu})$ .

We can define  $\tau$  on  $E'|_W$  by

$$\tau(Z, \xi) = (\sigma(Z), \xi^*),$$

where  $*$  denotes hermitian conjugation, and on  $E'|_{\tilde{W}}$  by a similar formula. For this to be well-defined on the overlap of the coordinate systems  $W \cap \tilde{W}$  we require  $\xi^* F(Z) = \xi^* F(Z)^*$  and hence

$$F^\dagger = F,$$

where  $\dagger$  is defined by

$$F^\dagger(Z) = F(\sigma(Z))^*.$$

For  $\sigma_3$  and  $\sigma_4$  the argument is the same except that in the case of  $\sigma_3$  we should now take  $W, \tilde{W}$  so that  $\sigma_3$  maps  $W$  to  $\tilde{W}$  and  $\tilde{W}$  to  $W$ , i.e. by choosing  $W$  and  $\tilde{W}$  containing  $\text{Im}(\zeta) > 0$  and  $\text{Im}(\zeta) < 0$  and . Again the condition on  $F$  is  $F^\dagger = F$ .

## 2.3 Reductions

In this section we shall review the process of obtaining integrable systems from the ASDYM equations by imposing conformal symmetries, concentrating on reductions by a 1-dimensional group of symmetries, and the corresponding reduction of the twistor transform. First let us consider the most well known reduction — obtaining the Bogomol'nyi equations in Euclidean space  $\mathbb{E}^3$  from the ASDYM equations in  $\mathbb{E}^4$ .

### The Bogomol'nyi Equations on $\mathbb{E}^3$

Consider an ASD connection  $D = d + A$  on  $\mathbb{E}^4$ . If  $A$  is invariant under the 1-dimensional subgroup of translations generated by  $\partial_4$ , i.e. if  $A_1, \dots, A_4$  depend only on  $x^1, x^2$  and  $x^3$ , then if we put set  $\Phi = A_4$ , the ASDYM equations imply the Bogomol'nyi equations

$$D_1\Phi = -F_{23}, \quad D_2\Phi = -F_{31}, \quad D_3\Phi = -F_{12}$$

or equivalently

$$D\Phi = -*F.$$

If we perform a gauge transformation  $g$ , where  $g$  depends on  $x^4$  then the gauge potential is no longer independent of  $x^4$ , although of course it is gauge equivalent to one that is. It is therefore better to have a notion of an invariance which does not depend on the particular choice of gauge.

### Invariant Connections

Another way of expressing the notion of invariance in the previous example is to say that for all translations  $\rho$  in the  $x^4$  direction the pullback  $\rho^*A$  of the form  $A$  is itself  $A$ . The way of making the definition independent of the choice of gauge is to define the pullback of a connection. Suppose  $H$  is a group of transformations on a manifold  $M$  with Lie algebra  $\mathfrak{h}$ . To define the action of  $H$  on the connection we need the notion of a lift of  $H$  to the bundle  $E$ . This is an assignment to each  $\rho \in H$  of a map  $\rho_* : E \rightarrow E$  such that for each  $x \in M$ ,  $\rho_*$  restricted to  $E_x$  is an isomorphism onto  $E_{\rho(x)}$  and  $(\rho_1\rho_2)_* = \rho_{1*}\rho_{2*}$ . Given a local section  $s : U \rightarrow E$  on an open set

$U$ , we can define the pullback section of  $s$  by  $\rho \in H$  on  $\rho^{-1}(U)$  by

$$\rho^*s(x) = \rho_*^{-1}(s(\rho(x))).$$

Then if  $D = d + A$  with respect to a trivialisation, i.e. a frame  $\{e_i\}$  of local sections  $e_i : U \rightarrow E$ , we define the pullback connection  $\rho^*D$  by  $\rho^*D = d + \rho^*A$  with respect to the frame  $\{\rho^*e_i\}$ . The connection is invariant if  $\rho^*D = D$ . If we choose an invariant frame, i.e. one for which  $\rho^*e_i = e_i$ , on  $U \cap \rho^{-1}(U)$ , then the connection is invariant if  $\rho^*A = A$ . The lift enables us to define a Lie derivative  $\mathcal{L}$  on sections of  $E$ , which is given locally by  $\mathcal{L}_X s = X(s) + \theta_X s$ , where  $X \in \mathfrak{h}$  and  $\theta_X$  is a matrix valued function. The condition that a section is invariant is  $\mathcal{L}_X s = 0$  and with respect to an invariant frame  $\theta_X = 0$ . Of course choosing such a frame corresponds to fixing a gauge, which we call an invariant gauge. Such invariant gauges can be chosen locally as long as the action on  $M$  is free. Given a connection invariant under  $X \in \mathfrak{h}$ , we define the Higgs field  $\Phi$  as the difference between the covariant derivative and the Lie derivative in the direction of the infinitesimal generator  $X$ , given locally by  $\Phi_X = A(X) - \theta_X$ . Under gauge transformations  $\Phi_X \rightarrow g^{-1}\Phi_X g$ . In more geometric language  $\Phi_X$  is a section of the adjoint bundle of  $E$ .

For example suppose one considers ASD connections on a bundle  $E$  over a manifold  $M$  which is  $\mathbb{E}^4$  with the plane  $x^3 = 0, x^4 = 0$  removed. If we choose polar coordinates  $x^3 = r \cos \theta, x^4 = r \sin \theta$  and put  $x^1 = x, x^2 = y$  then the ASDYM equations are

$$F_{xy} = -\frac{1}{r}F_{r\theta}, \quad F_{yr} = -\frac{1}{r}F_{x\theta}, \quad F_{rx} = -\frac{1}{r}F_{y\theta}.$$

Now consider connections invariant under  $X = \partial_\theta$ . In a gauge which is invariant under  $X$ ,  $\theta_X = 0$  so that the Higgs field  $\Phi = \Phi_X$  is just  $A_\theta$ , and the components of the gauge potential  $A_x, A_y$  and  $A_r$  together with  $\Phi$  are independent of  $\theta$ . The equations are then equivalent to

$$F_{xy} = -\frac{1}{r}D_r\Phi, \quad F_{yr} = -\frac{1}{r}D_x\Phi, \quad F_{rx} = -\frac{1}{r}D_y\Phi.$$

These are just the Bogomol'nyi equations  $D\Phi = -*F$  where  $*$  is the Hodge star on hyperbolic space  $H^3$ . This is the open upper half-space

$$H^3 = \{(x, y, r) \in \mathbb{R}^3 : r > 0\}$$

equipped with the metric

$$ds^2 = \frac{dx^2 + dy^2 + dr^2}{r^2}.$$

To understand why this is true note that  $M$  is conformally equivalent to the product of  $H^3$  and the circle  $S^1$ . The ASDYM equations are conformally invariant with conformal weight zero, so a solution on one space is also a solution on the other. Then just as for the Euclidean case, imposing invariance with respect to the coordinate on the 1-manifold gives the Bogomol'nyi equation on the 3-manifold  $H^3$ . This equation was considered by Atiyah [20]. Its solutions, with appropriate boundary conditions, correspond to monopoles on  $H^3$ . We shall discuss these further in Chapter 5. Note that, even if the bundle  $E$  is trivial, the corresponding frame need not be invariant as  $M$  is not topologically trivial and a gauge potential satisfying  $\rho^*A = A$  may not exist globally. This is still the case if the connection is defined on a bundle over the whole of  $\mathbb{E}^4$  as the action of  $H$  fixes the plane  $r = 0$  and is not free. In this case, if the gauge group is  $SU(2)$  then the action of  $\theta \rightarrow \theta + \alpha$  on the fibre of  $E$  above a point of  $r = 0$  is conjugate to

$$\begin{pmatrix} e^{ip\alpha} & 0 \\ 0 & e^{-ip\alpha} \end{pmatrix},$$

for some integer  $p \geq 0$ . This integer corresponds to the asymptotic value of the norm of the Higgs field and such monopoles are called integral hyperbolic monopoles. Non-integral monopoles correspond to connections on bundles over  $M$  which do not extend to the whole of  $\mathbb{E}^4$ .

### Conformal Symmetries and Isometries

If  $U \subseteq \mathbb{CM}$  and  $\rho : U \rightarrow \rho(U)$ , then  $\rho$  is conformal if  $\rho^*g = \Omega^2g$  for some function  $\Omega$  and proper if  $\rho^*\nu = \Omega^4\nu$ . If  $K$  is the infinitesimal generator of  $\rho$  (the conformal Killing vector), then this condition is

$$\partial_{(\lambda}K_{\mu)} = \frac{1}{4}g_{\lambda\mu}\partial_\nu K^\nu,$$

i.e. the left-hand-side is proportional to the metric tensor. If  $\Omega = 1$  then  $\rho$  is an isometry and in terms of the Killing vector  $\partial_\nu K^\nu = 0$ . In double null coordinates the equations are

$$\partial_w a + \partial_{\tilde{w}} \tilde{a} = \partial_w a + \partial_{\tilde{w}} \tilde{b},$$



$$\begin{aligned}\partial_z a &= \partial_{\tilde{w}} \tilde{b}, & \partial_z \tilde{a} &= \partial_w b, & \partial_z a &= \partial_{\tilde{w}} b, & \partial_z \tilde{a} &= \partial_{\tilde{w}} b \\ \partial_{\tilde{w}} a &= \partial_{\tilde{w}} \tilde{z} = \partial_w \tilde{a} = \partial_w \tilde{b} & & & & & & = 0.\end{aligned}$$

Since a conformal transformation preserves the metric up to scale, it takes null 2-planes to null 2-planes. If the transformation is proper (i.e. orientation preserving), it takes  $\alpha$ -planes to  $\alpha$ -planes (and  $\beta$ -planes to  $\beta$ -planes). Thus a conformal transformation generated by  $X$  induces a flow on the twistor space  $\mathcal{P}$  and the correspondence space  $\mathcal{F}$ . Clearly if  $X$  is of the form

$$a\partial_w + b\partial_z + \tilde{a}\partial_{\tilde{w}} + \tilde{b}\partial_{\tilde{z}}$$

then  $X''$  is of the form

$$a\partial_w + b\partial_z + \tilde{a}\partial_{\tilde{w}} + \tilde{b}\partial_{\tilde{z}} + Q\partial_\zeta,$$

for some function  $Q$ , i.e.  $\nu_* X'' = X$ . For example when  $X$  generates a translation it maps  $\alpha$ -planes to parallel  $\alpha$ -planes, thus  $\zeta$  remains constant along the flow and  $Q$  is zero. In general this will not be the case. If we put  $w = re^{i\theta}$ ,  $\tilde{w} = -re^{-i\theta}$  then the image of an  $\alpha$ -plane under a “rotation” generated by  $\partial_\theta$  will no longer be parallel. The  $\alpha$ -plane is spanned by vectors  $l' = e^{i\theta}l$  and  $m$  so since

$$l' = \frac{1}{2}\partial_r + \frac{i}{2}\partial_\theta - \zeta e^{i\theta}\partial_z, \quad m = \partial_z - \zeta e^{i\theta}\left(-\frac{1}{2}\partial_r + \frac{i}{2}\partial_\theta\right)$$

the transformation  $\theta \mapsto \theta + \alpha$  clearly takes  $\zeta$  to  $\zeta e^{-i\alpha}$  and  $Q = -i\zeta$ .

More generally the condition for  $X''$  to generate the flow in  $\mathcal{F}$  corresponding to the behaviour of  $\alpha$ -planes under  $X$  is that the Lie derivative  $\mathcal{L}_{X''}l = 0$ ,  $\mathcal{L}_{X''}m = 0$ , modulo linear combinations of  $l$  and  $m$ . If we take  $Q = \zeta^2 a_z + \zeta(\tilde{b}_z - a_w) - \tilde{b}_w$  then  $X''$  has the desired property.

If we consider the form of the twistor variables

$$\lambda = \zeta w + \tilde{z}, \quad \mu = \zeta z + \tilde{w}$$

then clearly

$$X' = (\zeta a + \tilde{b} + wQ)\partial_\lambda + (\zeta b + \tilde{a} + zQ)\partial_\mu + Q\partial_\zeta. \quad (2.3)$$

If  $X'$  acts freely on  $\mathcal{P}$  then the set of orbits of  $\mathcal{P}$  under the flow generated by  $X'$  (i.e. the quotient space) is called the reduced twistor space,  $\mathcal{R}$ .

## Reductions of the twistor transform and reduced twistor space

If a connection is invariant under the action of a conformal symmetry  $h \in H$ , then the action maps parallel sections of  $E$  over  $Z$  to parallel sections over  $h(Z)$ , and thus the action of  $H$  on  $\mathcal{P}$  lifts to the bundle  $E'$ . The converse also holds. Thus

**Proposition 2.2** *An ASDYM connection on a bundle  $E$  over  $U$  is invariant under the action a subgroup  $H$  of the conformal group if and only if the holomorphic action of  $H$  on  $\mathcal{P}$  lifts to  $E'$ .*

Away from the singular set — the set of points in  $\mathcal{P}$  which remain fixed by  $X'$  — there exist local invariant sections of  $E'$ . The pullbacks to  $\mathcal{F}$  satisfy  $\mathcal{L}_{X''}s = 0$  as well as of course  $D_l s = D_m s = 0$ . One can eliminate the ignorable space-time coordinate — i.e. the coordinate along  $X$  to obtain a Lax pair on the quotient of  $U$  by the action of  $H$ . For example if  $X = \partial_w + \partial_{\tilde{w}}$  and  $y = \frac{1}{2}(w - \tilde{w})$  then the linear system becomes

$$Ls = (D_y + \Phi - 2\zeta D_z)s, \quad Ms = (2D_z - \zeta(-D_y + \Phi))s$$

where the section  $s$  is a function of  $z, \tilde{z}, y$  and  $\zeta$ . We shall discuss this example further in Section 3.1.

In general  $X$  will not map  $\alpha$ -planes to parallel  $\alpha$ -planes. Then  $X''$  will have a non-zero component in the  $\zeta$  direction. In this case we take coordinates on the quotient of the correspondence space under the action of  $H$ , consisting of coordinates on the quotient of the space-time by  $H$  and an invariant spectral parameter which is constant along  $X''$ . If we take  $w = re^{i\theta}$ ,  $\tilde{w} = -re^{-i\theta}$  and  $X$  to be

$$\partial_\theta = i(w\partial_w - \tilde{w}\partial_{\tilde{w}})$$

then

$$X'' = \partial_\theta - i\zeta\partial_\zeta.$$

If we put  $\sigma = \zeta e^{i\theta}$  then  $X''(\sigma) = 0$  so  $\sigma$  is an appropriate choice of spectral parameter. If  $s$  is a section of  $E''$  satisfying  $\mathcal{L}_{X''}s = 0$  then in an invariant gauge  $s$  is a function of  $z, \tilde{z}, r$  and  $\sigma$  only.

In obtaining the appropriate reduction of the Lax pair one needs to be careful in handling derivatives. In these coordinates

$$\begin{aligned} Ls &= \left( D_r + \frac{1}{ir} D_\theta - 2\zeta e^{i\theta} D_z \right) s \\ Ms &= \left( 2D_z - \zeta e^{i\theta} \left( -D_r + \frac{1}{ir} D_\theta \right) \right) s. \end{aligned}$$

The  $\theta$  derivative is taken with  $\zeta$  held fixed. If we take a section invariant under  $X''$  then one should replace the  $\zeta$ -fixed  $\theta$ -derivative  $(\partial_\theta)_\zeta$  with the combination  $(\partial_\theta)_\sigma + i\sigma\partial_\sigma$ . Then  $s$  is a function of  $z$ ,  $\tilde{z}$ ,  $r$  and  $\sigma$  and the Lax pair becomes

$$\begin{aligned} Ls &= \left( D_r + \frac{1}{ir} \Phi + \frac{\sigma}{r} \partial_\sigma - 2\sigma D_z \right) s \\ Ms &= \left( 2D_z - \sigma \left( -D_r + \frac{1}{ir} \Phi + \frac{\sigma}{r} \partial_\sigma \right) \right) s. \end{aligned}$$

If one chooses a spectral parameter which is a twistor variable then the Lax pair involves no derivative with respect to the spectral parameter. For example we may choose  $\lambda$  as our spectral parameter, in which case

$$\begin{aligned} \lambda &= \zeta w + \tilde{z} \\ &= \zeta r e^{i\theta} + \tilde{z} \\ &= r\sigma + \tilde{z} \end{aligned}$$

and the Lax pair becomes

$$\begin{aligned} Ls &= \left( D_r + \frac{1}{ir} \Phi - 2 \frac{(\lambda - \tilde{z})}{r} D_z \right) s \\ Ms &= \left( 2D_z - \frac{(\lambda - \tilde{z})}{r} \left( -D_r + \frac{1}{ir} \Phi \right) \right) s. \end{aligned}$$

If  $X'$  acts freely on  $\mathcal{P}$  then the set of orbits of  $\mathcal{P}$  under the flow generated by  $X'$  (i.e. the quotient space) is called the reduced twistor space,  $\mathcal{R}$ . This means, when  $H$  is 1-dimensional and  $X'$  acts freely on  $\mathcal{P}$ ,  $\mathcal{R}$  is 2-dimensional and invariant bundles  $E'$  over  $\mathcal{P}$  are the pullbacks of bundles, which we shall call  $E'$  also, over  $\mathcal{R}$ .

### Examples

1. If  $U = \mathbb{CM}$  and  $X = \partial_w + \partial_{\bar{w}}$  then the lift of  $X$  to  $\mathcal{P} = \mathbb{CP}^3 - \mathbb{CP}^1$  is  $X' = \zeta\partial_\lambda + \partial_\mu = \partial_{\tilde{\lambda}} + \tilde{\zeta}\partial_{\tilde{\mu}}$ . Then the quantities  $\zeta$  and  $\tilde{\zeta}$  are preserved by the action of

$H$ , as are the quantities  $\eta = \zeta\mu - \lambda$  and  $\tilde{\eta} = \tilde{\zeta}\tilde{\lambda} - \tilde{\mu}$ . Then  $(\eta, \zeta)$  and  $(\tilde{\eta}, \tilde{\zeta})$  provide coordinate systems for  $\mathcal{R}$ . Since for  $\zeta \in \mathbb{C} - \{0\}$ , we have  $\tilde{\eta} = \eta\zeta^{-2}$  we recognise this as  $T\mathbb{CP}^1$ , the holomorphic tangent bundle of  $\mathbb{CP}^1$ , or the standard line bundle  $\mathcal{O}(2)$ . Given a point  $p$  in  $U$ , the corresponding line  $\hat{p} \subseteq \mathcal{P}$  corresponds in  $\mathcal{R}$  to the Riemann sphere  $\eta = z\zeta^2 - 2y\zeta - \tilde{z}$  for complex  $z, \tilde{z}, y$ , i.e. it is a section of the bundle.

2. If  $U$  is

$$\{(w, z, \tilde{w}, \tilde{z}) \in \mathbb{CM} : w, \tilde{w} \neq 0\}$$

then the lift of  $X = w\partial_w - \tilde{w}\partial_{\tilde{w}}$  to  $\mathcal{P}$  is  $X' = -\mu\partial_\mu - \zeta\partial_\zeta$ . The quantities  $\lambda$  and  $\omega = \mu/\zeta = \tilde{\mu}$  are constant along the flow generated by  $X'$  and thus provide local coordinates for  $\mathcal{R}$ . Globally we find that  $\mathcal{R}$  is covered by four charts with coordinates  $(\lambda, \omega), (\lambda, \omega^{-1}), (\lambda^{-1}, \omega)$  and  $(\lambda^{-1}, \omega^{-1})$  and thus  $\mathcal{R}$  is  $\mathbb{CP}^1 \times \mathbb{CP}^1$ . Given a point  $p$  in  $U$ , the corresponding line  $\hat{p} \subseteq \mathcal{P}$  corresponds to the Riemann sphere  $\omega = z - \frac{r^2}{\lambda - \tilde{z}}$  in the reduced twistor space, for complex  $z, \tilde{z}, r$ .

## 2.4 Minitwistor Spaces

In this section we discuss how the reduced twistor spaces of Section 2.3 arise from the intrinsic geometry of space-time. In this context we will call them minitwistor spaces. This approach was first considered by Hitchin [21, 22] and expanded by Jones and Tod [23]. There is a correspondence between minitwistor spaces and a type of complex 3-manifold called a Einstein-Weyl manifold. For more details, in particular how this correspondence relates to that between twistor spaces and 4-manifolds, see the above references.

First recall the definition of an Einstein-Weyl manifold. Let  $W$  be a complex 3-manifold with an affine connection arising from a covariant derivative  $\nabla$  and a conformal structure — an equivalence class of conformally equivalent metrics. The conformal structure is determined by a null cone, a set of vectors given by the vanishing of a non degenerate quadratic form. Further if  $g$  is a representative metric assume that  $\nabla$  satisfies a compatibility condition  $\nabla_i g_{jk} = \omega_i g_{jk}$  for some 1-form  $\omega$ .

This is a Weyl space. In general, the Ricci tensor  $R_{ij}$  of  $\nabla$  is not symmetric since the connection is not necessarily a Levi-Civita connection. However, if in addition the symmetrisation  $R_{(ij)}$  of the Ricci tensor  $R_{ij}$  is a constant multiple  $\Lambda$  of the metric,

$$R_{(ij)} = \Lambda g_{ij}, \quad (2.4)$$

then  $W$  is called Einstein-Weyl.

A minitwistor space  $\mathcal{T}$  is a complex 2-manifold containing a rational curve (i.e. a holomorphic embedding of a Riemann sphere) whose normal bundle is  $\mathcal{O}(2)$ . We shall call such a curve special. Then, by a theorem of Kodaira, there is a three-parameter family of such curves (see [24]). We refer to these rational curves as special and call  $\mathcal{T}$  a minitwistor space. Now the parameter space  $W$  of special curves is a 3-manifold whose tangent space at a point  $x$  is  $\Gamma(C_x, N_x)$ , the holomorphic sections of the normal bundle  $N_x$  of the special curve  $C_x$  corresponding to the point  $x$ . This is a 3-dimensional vector space since  $N_x$  is isomorphic to  $\mathcal{O}(2)$ , and sections of this bundle are quadratic functions of the base space coordinate. A generic section of  $N_x$  has two distinct zeros. When a section has a duplicated root, the discriminant of the associated quadratic is zero and we call the corresponding vector null. So we can equip  $M$  with a conformal structure, i.e. a set of null-vectors, defined by the vanishing of a non-degenerate quadratic form, at each space-time point. To define a connection it is equivalent to define a set of geodesics. Given a non-null vector  $V$  at a point of  $\mathcal{T}$  we consider the 1-parameter family of special curves through the two zeros of the section corresponding to  $V$ . If  $V$  is null we choose the 1-parameter family of curves meeting the duplicated root tangentially. This defines a curve in  $W$  which we shall say is the (Weyl) geodesic in the direction of  $V$ . The parameter space with this conformal structure and connection is an Einstein-Weyl space. The set of special curves through a given point  $x$  of  $W$  is a hypersurface, which is null in the sense that the restriction to the hypersurface of a representative metric of the conformal structure is degenerate. The null hypersurface is totally geodesic, i.e. if one has vector tangent to it, the corresponding geodesic lies entirely within the hypersurface.

This motivates the converse construction: given an Einstein-Weyl space  $W$  the

set  $\mathcal{T}$  of null, totally geodesic hypersurfaces is a complex 2-manifold. The set of such hypersurfaces through a point of  $W$  defines a special curve and thus  $\mathcal{T}$  is a minitwistor space. Thus there is a correspondence between minitwistor spaces and Einstein-Weyl manifolds which we shall call the Hitchin correspondence.

The two standard examples of minitwistor spaces are the holomorphic tangent bundle of the Riemann sphere  $T\mathbb{CP}^1$  and the quadric  $\mathbb{CP}^1 \times \mathbb{CP}^1$  (see [23]).

### $T\mathbb{CP}^1$

The special curves are precisely the holomorphic sections of the bundles. If  $\zeta$  is a base space coordinate and  $\eta$  is the fibre coordinate then the sections are of the form  $\eta(\zeta) = z\zeta^2 - 2y\zeta - \tilde{z}$ , for complex  $z$ ,  $\tilde{z}$  and  $y$ . The geodesics are straight lines in  $\mathbb{C}^3$  and thus  $\nabla$  is the Levi-Civita connection of the metric  $dz d\tilde{z} + dy^2$ . Thus the connection arising from  $\nabla$  is flat. The totally geodesic null hypersurfaces are null 2-planes, i.e. 2-planes whose normal vector is null.

### $\mathbb{CP}^1 \times \mathbb{CP}^1$

Consider  $\mathbb{CP}^1 \times \mathbb{CP}^1$  with coordinates  $(\lambda, \omega)$ . A straightforward calculation shows that the rational curve  $\{(\sigma, \sigma) : \sigma \in \mathbb{CP}^1\} \subseteq \mathbb{CP}^1 \times \mathbb{CP}^1$  is a special curve. If one performs a Möbius transformation on one of copies of  $\mathbb{CP}^1$  then this too is a special curve and one has a 3-parameter family. The set of special curves can be parameterised by complex coordinates  $r$ ,  $z$  and  $\tilde{z}$  with  $r$  non-zero as

$$\left\{ \left( r\sigma + \tilde{z}, -\frac{r}{\sigma} + z \right) : \sigma \in \mathbb{C} \cup \infty \right\}$$

or equivalently

$$\left\{ \left( \lambda, z - \frac{r^2}{\lambda - \tilde{z}} \right) : \lambda \in \mathbb{C} \cup \infty \right\}.$$

These are of course the same curves as for the reduced twistor space. The Weyl geodesics are those of the Levi-Civita connection of the metric  $dz d\tilde{z} + dr^2$  and thus the connection is the corresponding Levi-Civita connection.

## 2.5 Application to Instantons and Monopoles

In this section we shall outline how twistor methods can be applied to instantons and monopoles, focussing on those results in the monopole theory of Euclidean space which have analogues in hyperbolic space and in particular on results which are analogous to those results presented in Chapter 5. We shall concentrate on the gauge group  $SU(2)$ .

One of the major problems of the twistor transform is given a patching matrix for a bundle, can we perform the splitting? When the bundle rank,  $n$ , is one then the splitting is easily performed using Cauchy integrals. For  $n = 2$ , or for higher gauge groups, the splitting cannot necessarily be carried out explicitly. However when the bundle is an extension of one line bundle by another it is possible. Such bundles actually include those for all instantons and monopoles. The splitting leads to a number of ‘ansätze’  $\mathcal{A}_1, \mathcal{A}_2, \dots$  which relate solutions of linear equations to solutions of the ASDYM equations.

These ansätze are closely related to one method of constructing instanton bundles — the method of curves. A second method known as the ADHM construction uses another method of describing bundles, namely the monad construction of Horrocks. In the case of monopoles, all  $n$ -monopole solutions can be constructed from the ansatz  $\mathcal{A}_n$ , which involves the choice of a curve (the spectral curve) in minitwistor space, or by a version of the ADHM construction called the Nahm transform. There is also a description involving rational maps of the Riemann sphere. These methods allow the construction of a number of interesting solutions.

### The Ansätze $\mathcal{A}_n$

A rank-2 bundle is an extension of a line bundle  $L_1$  by another  $L_2$  if there is an exact sequence of bundles

$$0 \longrightarrow L_1 \xrightarrow{\alpha} E \xrightarrow{\beta} L_2 \longrightarrow 0.$$

In other words, each map is linear on its fibres,  $\alpha$  is injective,  $\beta$  is surjective and  $\text{im } \alpha = \ker \beta$ . If  $\Xi_i$  is the transition matrix for the bundle  $L_i$  from one neighbourhood

to another, then, in a suitable basis, the patching matrix  $F$  for  $E$  is

$$\begin{pmatrix} \Xi_1 & \Gamma \\ 0 & \Xi_2 \end{pmatrix}.$$

If  $U$  is a region of complexified Minkowski space-time whose twistor space  $\hat{U}$  is covered by two coordinate patches, then extensions of  $L_1$  by  $L_2$  are thus described by  $\Gamma$ . In fact  $\Gamma$  corresponds to an element of a certain vector space  $H^1(\hat{U}, \mathcal{O}(L_1 \otimes L_2^{-1}))$ , which is an example of a sheaf cohomology group. These are described in detail in [2]. Elements of such groups correspond to a solution of a linear equation, in this case a massless helicity- $(k-1)$  field coupled to a Maxwell field (this is the linear Penrose twistor transform). Suppose  $\Xi_1 = \Xi_2^{-1} = \zeta^k \exp(f)$  for some integer  $k$  and some function  $f$  of  $Z^\alpha$ , and put  $g = f \circ \mu$  and  $\Omega = \Gamma \circ \mu$ , where  $\mu$  is the projection from correspondence space to twistor space. In this case we can split the patching matrix, i.e. find functions  $H, \tilde{H}$  such that  $G = \tilde{H}H^{-1}$ , i.e.

$$\begin{pmatrix} \zeta^k e^g & \Omega \\ 0 & \zeta^{-k} e^{-g} \end{pmatrix} = \begin{pmatrix} \tilde{a} & \tilde{b} \\ \tilde{c} & \tilde{d} \end{pmatrix} \begin{pmatrix} a & b \\ c & d \end{pmatrix}^{-1},$$

where we can assume  $ad - bc = 1$ . One can split  $g$ , as in the rank-1 case, as  $h - \tilde{h}$ , where  $h$  is holomorphic for  $\zeta < 1$  and  $\tilde{h}$  is holomorphic for  $\zeta > 1$ . Since  $ce^h = \tilde{c}\tilde{h}\zeta^k$ , and a similar result for  $d$  and  $\tilde{d}$ , we must have  $k \geq 0$ , else by a Louville argument  $c = d = 0$ . If  $\Delta_r$  are the Laurent coefficients given by

$$\Omega e^{-h-\tilde{h}} = \sum_{r=-\infty}^{\infty} \Delta_{-r} \zeta^r$$

then  $a, \dots, d$  are given by (see [2])

$$a = -e^h \zeta^{-k} \sum_{r=1}^{\infty} \theta_r \zeta^r, \quad b = -e^h \zeta^{-k} \sum_{r=1}^{\infty} \phi_r \zeta^r, \quad c = e^{-h} \sum_{r=0}^k c_r \zeta^r, \quad d = e^{-h} \sum_{r=0}^k d_r \zeta^r$$

and  $\tilde{a}, \dots, \tilde{d}$  by

$$\tilde{a} = e^{\tilde{h}} \zeta^{-k} \sum_{r=1}^{\infty} \theta_r \zeta^r, \quad \tilde{b} = e^{\tilde{h}} \zeta^{-k} \sum_{r=1}^{\infty} \phi_r \zeta^r, \quad \tilde{c} = e^{-\tilde{h}} \sum_{r=0}^k c_r \zeta^{r-k}, \quad \tilde{d} = e^{-\tilde{h}} \sum_{r=0}^k d_r \zeta^{r-k}.$$

where

$$\theta_r = \sum_{j=0}^k c_j \Delta_{j-k}, \quad \phi_r = \sum_{j=0}^k d_j \Delta_{j-k},$$



for constants  $c_0, \dots, c_k$ , and  $d_0, \dots, d_k$  such that  $c_0\phi_k - d_0\theta_k = 1$  and  $\theta_r = \phi_r = 0$  for  $1 \leq r \leq k$ , but which are otherwise arbitrary and correspond to a choice of gauge. This is possible if  $\det M \neq 0$ , where

$$M = \begin{pmatrix} \Delta_{-k+1} & \cdots & \Delta_0 \\ \vdots & \ddots & \vdots \\ \Delta_0 & \cdots & \Delta_{k-1} \end{pmatrix}. \quad (2.5)$$

Corresponding to the splitting  $g = h - \tilde{h}$  there is a Maxwell field given by

$$B_w - \zeta B_{\bar{z}} = -(\partial_w - \zeta\partial_{\bar{z}})h = -(\partial_w - \zeta\partial_{\bar{z}})\tilde{h}.$$

with a similar result for  $B_z - \zeta B_{\bar{w}}$ . For  $k > 1$  the  $\Delta_r$  satisfy

$$(\partial_w + 2B_w)\Delta_r = (\partial_{\bar{z}} + 2B_{\bar{z}})\Delta_{r+1}, \quad (\partial_z + 2B_z)\Delta_r = (\partial_{\bar{w}} + 2B_{\bar{w}})\Delta_{r+1},$$

for  $-k+1 \leq r \leq k-2$  and in the case  $k=1$

$$(\partial_\mu + 2B_\mu)(\partial^\mu + 2B^\mu)\Delta_0.$$

These are the equations of a massless field of helicity  $k-1$  coupled to a field  $B = B_\mu dx^\mu$ . There is a choice of gauge, called Yang's R-gauge, which corresponds to  $c_0 = d_k$ ,  $d_0 = c_k$ . If we take the corner elements of the inverse of the matrix  $M$  above,  $E = (M^{-1})_{11}$ ,  $F = (M^{-1})_{1k}$  and  $G = (M^{-1})_{kk}$ , then in this gauge

$$\begin{aligned} A_z &= \frac{1}{2F} \begin{pmatrix} \bar{\partial}_z F & 0 \\ -2\bar{\partial}_{\bar{w}} G & -\bar{\partial}_z F \end{pmatrix}, & A_{\bar{z}} &= \frac{1}{2F} \begin{pmatrix} -\bar{\partial}_{\bar{z}} F & -2\bar{\partial}_w E \\ 0 & \bar{\partial}_z F \end{pmatrix} \\ A_w &= \frac{1}{2F} \begin{pmatrix} \bar{\partial}_w F & 0 \\ -2\bar{\partial}_{\bar{z}} E & -\bar{\partial}_w F \end{pmatrix}, & A_{\bar{w}} &= \frac{1}{2F} \begin{pmatrix} -\bar{\partial}_{\bar{w}} F & -2\bar{\partial}_z E \\ 0 & \bar{\partial}_{\bar{w}} F \end{pmatrix}, \end{aligned}$$

where  $\bar{\partial}_\mu = \partial_\mu - 2B_\mu$ . In particular taking  $k=1$  and  $f=0$  gives the t'Hooft ansatz,

$$A_\mu = i\tilde{\sigma}_{\mu\nu}\partial^\nu \log \Delta_0$$

Although an upper triangular  $F$  cannot satisfy the reality condition  $F^\dagger = F$ , it is enough that it is equivalent to one, i.e. that there are matrices  $K, \tilde{K}$  on  $W, \tilde{W}$  such that  $F' = \tilde{K}^{-1}FK$ . The R-gauge is not necessarily real, although it is equivalent to one that is.

**Example 2.1** Take  $k$  odd,  $f^\dagger = -f$  and  $\Gamma^\dagger = \Gamma$ . We shall use this in Chapter 5.

**Example 2.2** Take  $f^\dagger = f$ ,  $\Gamma = Q^{-1}(e^f + (-1)^k e^{-f})$  where  $Q = (Z^0 Z^1)^{-k} P(Z^\alpha)$  for a homogenous polynomial  $P$  of degree  $2k$  in the twistor variables satisfying  $P^\dagger = (-1)^k P$ . This example can in particular be used to construct BPS monopoles.

These two ansätze can be seen to satisfy the reality condition by taking  $\tilde{K}$  to be the identity in each case and  $K$  to be respectively

$$\begin{pmatrix} 0 & -1 \\ 1 & 0 \end{pmatrix} \quad \text{and} \quad \begin{pmatrix} 0 & -1 \\ 1 & \zeta^k Q \end{pmatrix}.$$

### Instantons

Instanton bundles, that is bundles  $E'$  corresponding to instanton solutions, are bundles over the full twistor space  $\mathbb{CP}^3$  and are, by a theorem of Serre, algebraic. In other words the transition matrices are rational functions of the twistor variables  $Z^\alpha$ . The second Chern class  $c_2(E')$  of the instanton bundle is  $-k$  where  $k$  is the instanton number of the bundle since its the pullback of  $E$ . The other invariant, the first Chern class of the bundle  $c_1(E')$ , is zero since the restriction of the bundle to a real line is trivial.

The first method of constructing such bundles is the method of curves. If  $z_0, \dots, z_n$  are homogenous coordinates on  $\mathbb{CP}^n$  then the hyperplane section bundle is a line bundle whose transition matrix from the patch  $U_\alpha = \{z_\alpha \neq 0\}$  to the patch  $U_\beta$  is  $z_\beta/z_\alpha$ . If one takes the hyperplane section bundle  $H$ , then  $E'(n) = E' \otimes H^n$  admits a global section  $s$  if  $n$  is sufficiently large. Such a section exists if  $n > (3c_2 + 1)^{1/2} - 2$ . If  $Y$  is the zero set of  $S$  and  $Y'$  its complement, then, because of the existence of  $s$ , there is a trivial line bundle  $I$  over  $Y'$  which is a subbundle of  $E'(n)|_{Y'}$  whose fibre  $I_x$  is the span of  $s(x)$ . So  $E'(n)$  is an extension of  $I$  by  $H^{2n}$  and is classified by an element of the sheaf cohomology group  $H^1(\tilde{U}, \mathcal{O}(H^{-2n}))$  and the gauge potential can be recovered as in the previous section. Thus the solution is determined by the curve. By choosing  $n$  sufficiently large one can ensure  $Y$  is connected, although it is often better to allow  $Y$  to be composed of connected components  $Y_1, \dots, Y_r$  and

to keep  $n$  as small as possible. In this case an element  $\Gamma$  of the sheaf cohomology group is a linear combination  $\sum_{i=1}^r \lambda_i \Gamma_i$  of elements of the cohomology groups over the complements of the connected components, and the solution is determined by the  $Y_i$  and by the  $\lambda_i$  up to an overall factor. If  $Y_i$  has genus  $g_i$  and degree  $d_i$  then  $g_i = (n-2)d_i + 1$  and  $\sum_{i=1}^r d_i = c_2 + n^2$ . For example if  $n = 1$  then  $d_i$  is 1,  $g_i = 0$  and  $c_2 = r - 1$ , and  $Y$  is the disjoint union of  $r$  lines. For each line one has an element  $\Gamma_i$  of the sheaf cohomology group  $H^1(Y_i', \mathcal{O}(H^{-2}))$  which corresponds to a solution of the Laplace equation, namely  $(x - x_i)^{-2}$ , and then  $\Gamma$  corresponds to the solution

$$\Delta_0 = \sum_{i=1}^r \frac{\lambda_i}{(x - x_i)^2}.$$

The second method is the method of monads. A monad is a sequence of bundles

$$F \xrightarrow{A} G \xrightarrow{B} H,$$

with  $\text{im } \alpha \subseteq \ker \beta$ . One can define a bundle by  $E' = \ker B / \text{im } A$ . For instantons we have a symplectic form  $\omega$  on  $G$ , so we can identify  $G$  with its dual and take  $H$  and  $B$  to be the duals of  $F$  and  $A$  respectively. To construct instanton bundles we take  $G$  to be trivial and  $F$  to be  $k$  copies of  $\mathcal{O}(-1)$ . We take  $V, W$  to be complex vector spaces of dimension  $2k+2$  and  $k$  respectively, and for each  $Z$  we let  $A(Z) : W \rightarrow V$  be a linear map depending linearly on the twistor variables, i.e.  $A(Z) = A_\alpha Z^\alpha$ . We require that  $\text{rank } A(Z)$  be  $k$  and the isotropy condition  $\text{Im } A(Z) \subseteq (\text{Im } A(Z))^\circ$  where  $U^\circ = \{v \in V : \forall w \in U \omega(u, v)\}$ . To reduce the gauge group to  $SU(2)$  we require  $A$  to satisfy a reality condition. If  $\sigma_W : W \rightarrow W$  and  $\sigma_V : V \rightarrow V$  are anti-holomorphic maps which satisfy  $\sigma_W^2 = 1$  and  $\sigma_V^2 = -1$  and which are compatible with the symplectic form in the sense that  $\omega(\sigma_V v_1, \sigma_V v_2) = \overline{\omega(v_1, v_2)}$ . The reality condition is then  $\sigma_V A(Z)w = A(\sigma Z)\sigma_W w$ . Such a map  $A$  is equivalent to another  $A'$  if there are matrices  $M \in Sp(k+1)$ ,  $N \in Gl_n(\mathbb{R})$  such that  $A' = MAN$ . Counting parameters shows that this gives an  $(8k-3)$ -dimensional space of solutions. If we identify a point  $(x^0, x^1, x^2, x^3)$  in  $\mathbb{E}^4$  with the quaternion  $x = x^0 - x^1 \mathbf{i} - x^2 \mathbf{j} - x^3 \mathbf{k}$ , choose suitable bases for  $V$  and  $W$  and identify and the Pauli matrices  $\sigma_1, \sigma_2, \sigma_3$  with  $-\mathbf{i}, -\mathbf{j}, -\mathbf{k}$  then the reality condition implies that we can regard  $A$  as a  $(k+1) \times k$  quaternion matrix  $M(x)$  with  $M(x) = B - C.x$  where  $B, C$  are quaternion-valued

matrices and  $\cdot$  denotes quaternion multiplication. The rank and isotropy conditions above are equivalent to the  $k \times k$  matrix  $M^*M$  being real and non-singular, where  $*$  denotes the quaternion conjugate transpose. If  $v$  is a  $(k+1)$ -dimensional quaternionic vector satisfying

$$v^*M = 0, \quad v^*v = 1, \quad (2.6)$$

then the a real gauge potential corresponding to  $E'$  is given by  $A_\mu = v^*\partial_\mu v$ . This is the ADHM construction. If one takes

$$M(x) = \begin{pmatrix} \lambda_1 & \lambda_2 & \dots & \lambda_k \\ x_1 - x & 0 & \dots & 0 \\ 0 & x_2 - x & & \\ \vdots & & \ddots & 0 \\ 0 & 0 & & x_k - x \end{pmatrix}$$

and

$$u^* = \left( 1 \quad \frac{\lambda_1}{x_1 - x} \quad \frac{\lambda_2}{x_2 - x} \quad \dots \quad \frac{\lambda_k}{x_k - x} \right), \quad v = \frac{u}{\|u\|},$$

then we recover the t'Hooft solution. Other solutions can be found by allowing the  $\lambda_i$  above to take quaternion values and taking the zero entries of  $M(x)$  to be non-zero.

The vector spaces in the monad construction correspond to sheaf cohomology groups. Thus the vector spaces  $V$ ,  $W$  and the dual of  $W$  correspond to solutions of linear field equations on  $S^4$  by the linear Penrose transform. For example the dual of  $W$  is the space of solutions of the Dirac equation in the presence of an instanton field and  $V$  is a space of pairs consisting of a solution of the Dirac equation together with a solution of the covariant Laplacian. When the instanton field is replaced by an ASD field corresponding to a BPS monopole, these solution spaces become infinite-dimensional.

## BPS Monopoles

These are solutions of the Bogomol'nyi equations  $D\Phi = -*F$  on  $\mathbb{E}^3$  satisfying certain boundary conditions, in particular

$$\|\Phi\| = 1 - \frac{n}{r} + O(r^{-2}), \quad (2.7)$$

where  $r$  is the radial distance  $(x^2 + y^2 + z^2)^{1/2}$  and  $n$  is the monopole number. Solutions of the Bogomol'nyi equations of course correspond to solutions of the ASDYM equations invariant under a 1-dimensional group of translations. Manton showed that one can construct the 1-monopole solution from the t'Hooft ansatz by putting  $\Delta_0 = \tilde{\Delta}_0 e^{ix^4}$  where  $\tilde{\Delta}_0 = 2r^{-1} \sinh r$ . The R-gauge does not give a real solution — this requires a complex gauge transformation. Manton also showed however that no other monopoles can be found this way.

One can construct higher charge solutions though by using the ansätze  $\mathcal{A}_n$  for  $n \geq 2$  and in particular taking  $\Gamma$  to be of the form of Example 2.2. Ward [25] constructed an axially-symmetric 2-monopole solution depending on 5-parameters, 3 position parameters and 2 parameters corresponding to the choice of axis, from the ansatz  $\mathcal{A}_2$ . Prasad and Rossi [26] constructed similar 5-parameter axially-symmetric solutions for  $n \geq 3$  generalising that of Ward, but did not show that these were smooth (by showing  $\det M$  is never zero). Ward's result was arrived at independently by Forgács, Horváth and Palla [27] using traditional integrable systems techniques. The 2-monopole Moduli space is 7-dimensional and Ward constructed a solution depending on the full 7 parameters [28] and showed that it was smooth when the monopoles were sufficiently close together. Corrigan and Goddard then constructed a full  $(4n - 1)$ -parameter family of solutions [29].

We shall now describe these solutions. To obtain translationally-invariant solutions we choose  $f$  and  $\Gamma$  to be dependent on the twistor variables only through the minitwistor variables introduced in Section 2.3, namely  $\zeta$  and  $\eta$ . In this case one has

$$\|\Phi\|^2 = 1 - \Delta \log D, \quad (2.8)$$

where  $D$  is the determinant of the matrix  $M$  in (2.5) above. One can take  $\Gamma$  as in Example 2.2 for some suitable  $Q$ . Take  $f$  to be a polynomial in  $\gamma = \eta/\zeta$  and choose  $\Gamma$  to be of the form,

$$\Gamma = \frac{\zeta^k}{S} (e^f + (-1)^k e^{-f}),$$

for a polynomial  $S$  of the form

$$S(\eta, \zeta) = \eta^n + a_1(\zeta)\eta^{n-1} + \dots + a_{n-1}(\zeta)\eta + a_n(\zeta),$$

where  $a_{n-k}(\zeta)$  is a polynomial in  $\zeta$  of degree less than or equal to  $2k$ . Since under the real structure  $\zeta^\dagger = -1/\bar{\zeta}$  and  $-\eta^\dagger = \bar{\eta}\bar{\zeta}^{-2}$  the reality condition is  $a_k(\zeta) = (-1)^k \zeta^{2k} \overline{a_k(-1/\bar{\zeta})}$ . Corrigan and Goddard showed that with such a  $\Gamma$  the boundary condition (2.7) is satisfied and also that for  $f = \eta/\zeta$  any choice of  $\Gamma$  is equivalent to one of the form above. They showed that to obtain non-singular solutions the  $(n+1)^2 - 1$  real parameters must satisfy  $(n-1)^2$  constraints, giving a full  $4n-1$  parameters. In fact in [21] Hitchin showed that we can obtain any monopole by taking  $f = \eta/\zeta$ .

**Example 2.3** The t'Hooft-Polyakov 1-monopole solution described in Chapter 1 can be constructed by putting  $S = \eta$ . Then  $\Delta_0 = 2r^{-1} \sinh r$  and by (2.8)  $\|\Phi\| = \coth r - r^{-1}$ . The solution is spherically symmetric and in particular its surfaces of constant energy density are spheres.

**Example 2.4** For  $n = 2$  take

$$S = \eta^2 + \pi^2 \zeta^2 / 4.$$

This is Ward's axially-symmetric 2-monopole. By applying translations and rotations one obtains a 5-parameter family. The Higgs field  $\Phi$  has a double zero at the origin so one thinks of this as the location of a monopole of charge 2. A surface of constant energy density is a torus.

**Example 2.5** One obtains the Prasad and Rossi solution by taking

$$S = \sum_{r=1}^n \left( \eta - \frac{1}{2} i\pi(n+1-2r)\zeta \right).$$

This generalises Ward's solution. Again the solutions are axially-symmetric and toroidal with an  $n$ -tuple zero at the origin.

**Example 2.6** If we take

$$S = \eta^2 - \frac{K^2}{4} (m + 2(m-2)\zeta^2) + m\zeta^4$$

where  $m \in [0, 1)$  and  $K$  is the complete elliptic integral of the first kind

$$\int_0^{\pi/2} \frac{d\theta}{\sqrt{1 - m \sin^2 \theta}}$$

45

This represents a 2-monopole configuration and the parameter  $m$  is related to the distance between the monopole. When  $m = 0$  this reduces to Ward's 2-monopole solution, Example 2.4, and as  $m$  tends to 1,  $S$  is asymptotic to the product

$$S = \left(\eta + \frac{K}{2}(1 - \zeta^2)\right)\left(\eta - \frac{K}{2}(1 - \zeta^2)\right)$$

and represents a pair of monopoles with zeros at  $(\pm K, 0, 0)$ . This gives a 1-parameter family of solutions; one can add 6 further parameters by applying rotations and translations. One thinks of these parameters as the locations of the two monopoles plus a relative phase. The solutions are not axisymmetric, rotations about the axis joining the zeros change the relative phase of the monopoles. This solution was originally presented by Ward in a slightly different form. He took  $f = \frac{1}{2}\pi\gamma/\sqrt{2\delta}$ ,  $Q = f^2 + \gamma$  where

$$\delta = \frac{1}{2}pq(\zeta - \zeta^{-1}) + q,$$

where the branch of the square root with positive real part is taken,  $p$  is a real parameter and  $q$  (also real) is given in terms of an elliptic integral,

$$\sqrt{q} = \frac{1}{4} \int_0^{2\pi} \frac{d\theta}{\sqrt{1 + ip \sin \theta}}.$$

In terms of bundles the solutions correspond to bundles over  $\mathcal{T} = T\mathbb{C}P^1$ . Hitchin [21] showed that we can think of  $\mathcal{T}$  as the space of oriented straight lines in  $\mathbb{E}^3$ . From our point of view a point in  $\mathcal{T}$  is a null plane in  $\mathbb{C}^3$ . The intersection of this plane with the set of real points is a straight line (Recall that real points correspond to real sections of  $\mathcal{T}$  — those preserved by the real structure  $(\eta, \zeta) \mapsto (\bar{\gamma}\bar{\zeta}^{-2}, -\bar{\zeta}^{-1})$ , which is the one appropriate for  $\mathbb{E}^3$ ). The image of a null plane under the real structure determines the same line. The vector

$$\left( \frac{2 \operatorname{Re}(\zeta)}{1 + |\zeta|^2}, \frac{2 \operatorname{Im}(\zeta)}{1 + |\zeta|^2}, \frac{1 - |\zeta|^2}{1 + |\zeta|^2} \right)$$

is a unit vector in the direction of the line and is reversed by the real structure. Thus we can regard the points of minitwistor space as oriented lines whose orientation is reversed by the real structure.

The fibre of the bundles  $E'$  over an oriented straight line is the solution space of

$$(D_u - i\Phi)s = 0,$$

where  $D_u$  denotes the covariant derivative in the (positive) direction of that line. The fibre  $E'_l$  contains a 1-dimensional subspace  $I_l$  of solutions which decay exponentially as one approaches infinity in the positive direction of the directed line. This determines a line bundle which is a sub-bundle and thus all monopoles can be obtained from the ansätze  $\mathcal{A}_i$ . (In fact all  $n$ -monopoles can be obtained from  $\mathcal{A}_n$ ). Those lines for which the subspaces of solutions which decay exponentially in the positive and negative direction coincide forms a holomorphic curve in  $\mathcal{T}$ . In fact it is algebraic and given by the vanishing of the polynomial  $S$  above. This curve is called the spectral curve and is a curve of genus  $(n - 1)^2$ .

Donaldson [30] showed the moduli space of monopole solutions (including a global phase) is diffeomorphic to the space of degree  $k$  based rational maps  $R : \mathbb{CP}^1 \longrightarrow \mathbb{CP}^1$ , that is maps of the form

$$R(z) = \frac{a(z)}{b(z)}$$

where  $b$  is a polynomial of degree  $k$  and  $a$  is a polynomial of degree less than  $k$ , with no factors in common with  $b$ . A concrete description of this was provided by Hurtubise [31]. The subspace  $I_l$  of  $E_l$  defines a point of  $\mathbb{CP}^1$ . If one fixes a directed line in  $\mathbb{E}^3$ , say the  $z$ -axis, then the set of directed lines parallel to this (with the same orientation) can be identified with  $\mathbb{C}$ . The map  $R$  is given by mapping  $z \in \mathbb{C}$  to the point of  $\mathbb{CP}^1$  corresponding to  $I_l$ , where  $l$  corresponds to  $z$ . The main problem with this method is that it is difficult to recover any information about the monopole from the rational map. In a similar description due to Jarvis one fixes a point  $P$  and identifies the points  $z$  in  $\mathbb{CP}^1$  with directed lines through  $P$ . One then defines  $R(z)$  as before. The maps are no longer based, so  $a$  can have degree up to and including  $k$ , a gauge transformation corresponds to an  $SU(2)$  Möbius transformation.

Just as for instantons one can construct monopole solutions using the method of monads. This approach is due to Nahm [32] and is called the ADHMN (Atiyah-Drinfeld-Hitchin-Manin-Nahm) construction or Nahm transform. The vector spaces analogous to the  $W$  and  $V$  in the instanton case are now infinite-dimensional. One way of understanding this is that, for example, the solution space of the Dirac equation in the presence of solutions of the ASDYM, which correspond to the dual



of  $V$ , is infinite-dimensional when the gauge field is translationally-invariant.

The Nahm data for constructing a  $k$ -monopole consists of  $k \times k$  matrices  $T_1, T_2, T_3$  depending on a parameter  $s \in [0, 2]$  such that

i) The  $T_i$  satisfy

$$\frac{dT_1}{ds} = [T_2, T_3]$$

and cyclic permutations,

ii)  $T_i$  are regular in  $(0, 2)$  with simple poles at 0 and 2,

iii) the residues of the poles of  $(T_1, T_2, T_3)$  at 0 and 2 form the irreducible  $k$ -dimensional representation of  $SU(2)$ ,

iv)  $T_i(s) = -T_i^\dagger(s)$ ,

v)  $T_i(s) = T_i^t(2 - s)$ .

Hitchin showed an equivalence between Monopoles and Nahm data [33].

Recall that in the ADHM construction one considers  $(k + 1)$ -dimensional vectors  $v(x)$  satisfying (2.6). In the monopole case  $v$  is a function of the three space coordinates and takes values in  $\mathbb{C}^k \otimes \mathbb{C}^2 \otimes \mathcal{L}^2(0, 2)$ . Here we can think of  $\mathbb{C}^2$  as the quaternions and  $v$  as  $k$ -dimensional quaternion or  $\mathbb{C}^k \otimes \mathbb{C}^2$ -valued function  $v(x^i, s)$ .

The analogues of  $v^*v = 1$  and  $v^*M = 0$  are

$$\int_0^2 v^*v ds = 1$$

and

$$\left(i \frac{d}{ds} + \mathbf{1}_k \otimes x^j \sigma_j + iT_i \otimes \sigma_j\right)v = 0$$

respectively, where  $\mathbf{1}_k$  is the  $k \times k$  identity matrix. One recovers the gauge potential and Higgs field as

$$A_i = \int_0^2 v^* \partial_i v ds, \quad \Phi = \int_0^2 sv^*v ds.$$

The advantage with Nahm's method is that the fields above are guaranteed to be smooth — there are no difficult singularity conditions.

If one writes

$$\Lambda = (T_1 + T_2) - 2T_3\zeta + (T_1 - T_2)\zeta^2, \quad \Lambda_+ = -iT_3 + (T_1 - iT_2)\zeta$$

then the Nahm equations have a Lax-type description

$$\frac{d}{ds}\Lambda = [\Lambda, \Lambda_+].$$

This means in particular that for each  $\zeta$  the eigenvalues of  $\Lambda$  are constant. The union of points of the form  $(\eta, \zeta)$  where  $\eta$  is an eigenvalue of  $\Lambda$  is an algebraic curve (since it satisfies the eigenvalue equation) and is in fact the spectral curve.

These methods can be used to construct a number of examples of monopoles. However the difficulty of implementing these increases with the monopole number, and they soon become intractable. Progress has been made though in constructing monopole configurations with a number of symmetries [34]. For example there is a 3-monopole with tetrahedral symmetry. Its Higgs field has 5 zeros, four zeros with positive winding number at the corners of a tetrahedron and one with negative winding number at the centre (an anti-monopole). There is also a cubic 4-monopole with no anti-monopoles, an octahedral 5-monopole with 6 monopoles at the vertices and an anti-monopole at the centre and a dodecahedral 7-monopole.

# Chapter 3

## Bogomol'nyi Equations on Constant Curvature Space-times

In this chapter we shall discuss Bogomol'nyi equations in  $(2 + 1)$ -dimensions. Recall that the Bogomol'nyi equations on a 3-manifold  $M$  are

$$D\Phi = -*F,$$

where  $D$  is a connection on a bundle  $E$  over  $M$ ,  $\Phi$  is a section of the adjoint bundle and  $*$  is the Hodge star. In components

$$D_\mu\Phi \equiv \partial_\mu\Phi + [A_\mu, \Phi] = -\frac{1}{2}\Delta\epsilon_{\mu\alpha\beta}F^{\alpha\beta},$$

where  $\Delta = \sqrt{|\det(g_{\mu\nu})|}$ ,  $\epsilon$  is the Levi-Civita symbol with  $\epsilon_{123} = 1$  and the volume form is  $\nu = \Delta dx^1 \wedge dx^2 \wedge dx^3$ . One can of course also consider solutions of the equation  $D\Phi = *F$  which is equivalent to changing the orientation of the space-time (i.e. changing the sign of the volume form).

For Minkowski space-time the equations are obtained by considering ASD connections in  $(2 + 2)$ -dimensional ultrahyperbolic space-time invariant under a 1-dimensional group of translations and thus are an example of an integrable system. For arbitrary manifolds the equations are not integrable. However in this chapter we shall show that when the manifold has constant curvature the equations can be obtained from the ASDYM equations in  $(2 + 2)$ -dimensions and thus are integrable.

Recall that an  $n$ -manifold  $M$  with metric  $g$  and Levi-Civita connection  $\nabla$  has curvature

$$R(X, Y)Z = (\nabla_X \nabla_Y - \nabla_Y \nabla_X - \nabla_{[X, Y]})Z$$

or in coordinates

$$R(X, Y)Z = R_{\kappa\lambda\mu}{}^\nu X^\kappa Y^\lambda Z^\mu \partial_\nu$$

where

$$R_{\kappa\lambda\mu}{}^\nu \partial_\nu = (\nabla_\kappa \nabla_\lambda - \nabla_\lambda \nabla_\kappa) \partial_\mu$$

The Ricci curvature is given by

$$R_{\kappa\mu} \equiv R_{\kappa\lambda\mu}{}^\lambda$$

and the scalar curvature by

$$R = R_\kappa{}^\kappa.$$

A space-time is of constant curvature if

$$R_{\kappa\lambda\mu\nu} = \frac{1}{n(n-1)} R (g_{\kappa\mu} g_{\lambda\nu} - g_{\kappa\nu} g_{\lambda\mu}).$$

This is equivalent to

$$R_{\kappa\lambda} = \frac{1}{n} R g_{\kappa\lambda}.$$

There are three standard space-times of constant curvature — Minkowski space-time, deSitter space-time and anti-deSitter space-time — with (constant) zero, positive or negative scalar curvature.

### 3.1 Minkowski Space-time

The constant curvature manifold with zero scalar curvature is of course Minkowski space-time. Ward considered Bogomol'nyi equations on  $(2+1)$ -dimensional space-time in [35, 36, 37, 38], mostly from the point of view of the related integrable chiral model. We shall take Minkowski space-time  $\mathbb{M}^{2+1}$  to be  $\mathbb{R}^3$  with coordinates  $(x, y, t)$ , metric  $dx^2 + dy^2 - dt^2$  and volume form  $dx \wedge dy \wedge dt$ .

The Bogomol'nyi equations are

$$D_t\Phi = -F_{xy}, \quad D_x\Phi = +F_{yt}, \quad D_y\Phi = +F_{tx}.$$

These are equivalent to the ASDYM equations on  $(2+2)$ -dimensional ultrahyperbolic space-time  $\mathbb{U}$  invariant under a 1-dimensional group of time-like translations. If we take  $\mathbb{U}$  to be  $\mathbb{R}^4$  with coordinates  $(x, y, t, u)$ , metric  $dx^2 + dy^2 - dt^2 - du^2$  and volume form  $dx \wedge dy \wedge dt \wedge du$  then the ASDYM equations are

$$F_{ut} = -F_{xy}, \quad F_{xu} = +F_{yt}, \quad F_{yu} = +F_{tx}.$$

If  $A_x, A_y, A_t, A_u$  are independent of  $u$  and we put  $A_u = \Phi$  then these reduce to the Bogomol'nyi equations on  $\mathbb{M}^{2+1}$ . In terms of double-null coordinates we take the real slice  $\mathbb{U}_1$  introduced in Section 2.1, fixed by  $\sigma_3$ , corresponding to  $z, \tilde{z}, w, \tilde{w}$  real, and take coordinates

$$\begin{pmatrix} \tilde{z} & w \\ \tilde{w} & z \end{pmatrix} = \begin{pmatrix} x+t & y+u \\ -y+u & x-t \end{pmatrix}.$$

Then ASD connections on a neighbourhood  $U$  of  $\mathbb{U}_1$  invariant under the group  $H$  of translations generated by  $\partial_w + \partial_{\tilde{w}}$  correspond to (real analytic) solutions of the Bogomol'nyi equations on  $\mathbb{M}^{2+1}$ . In fact these are solutions of  $D\Phi = *F$  since the volume form  $\frac{1}{4}dw \wedge d\tilde{w} \wedge dz \wedge d\tilde{z}$  is  $-dx \wedge dy \wedge dt \wedge du$ .

Recall from Section 2.3 that the lift of  $X = \partial_w + \partial_{\tilde{w}}$  is  $X'' = \partial_w + \partial_{\tilde{w}}$ . Since the connection is invariant under  $H$  we can find sections  $s$  satisfying the linear system  $Ls = 0, Ms = 0$  satisfying  $\mathcal{L}_{X''}s = 0$ , and in an invariant gauge the Lax pair becomes

$$\begin{aligned} L &= (D_y + \Phi) - \zeta(D_x + D_t) \\ M &= (D_x - D_t) - \zeta(-D_y + \Phi). \end{aligned}$$

If  $f$  is a fundamental matrix solution of the linear system we can recover the gauge potential and Higgs field as

$$\begin{aligned} (A_y + \Phi) - \zeta(A_x + A_t) &= -l(f)f^{-1} \\ (A_x - A_t) - \zeta(-A_y + \Phi) &= -m(f)f^{-1}, \end{aligned}$$

where  $l = \partial_y - \zeta(\partial_x + \partial_t)$ ,  $m = \partial_x - \partial_t + \zeta\partial_y$ . If  $f$  is a  $2 \times 2$  matrix and satisfies the reality condition

$$f(x, y, t, \bar{\zeta})^* = f(x, y, t, \zeta)^{-1}$$

for real  $x, y, t$  then  $A$  and  $\Phi$  are  $\mathfrak{su}(2)$ -valued.

The compatibility condition for the Lax pair implies we can find functions  $h, \tilde{h}$  such that

$$(D_y + \Phi)h = 0, \quad (D_x - D_t)h = 0$$

and

$$(D_x + D_t)\tilde{h} = 0, \quad (-D_y + \Phi)\tilde{h} = 0.$$

If we define  $J = \tilde{h}h^{-1}$  then  $J$  satisfies the  $J$ -matrix equation

$$-(J^{-1}J_t)_t + (J^{-1}J_x)_x + (J^{-1}J_y)_y + [J^{-1}J_x, J^{-1}J_t] = 0.$$

If we choose a gauge in which  $\Phi = -A_y$ ,  $A_x = A_t$  then

$$\Phi = -A_y = -\frac{1}{2}J^{-1}J_y, \quad A_x = A_t = \frac{1}{2}J^{-1}J_x + \frac{1}{2}J^{-1}J_t.$$

When  $J$  is  $SU(2)$ -valued the gauge potential and Higgs field are  $\mathfrak{su}(2)$ -valued.

The equation of the  $SU(2)$  chiral model on  $\mathbb{M}^{2+1}$  is

$$-(J^{-1}J_t)_t + (J^{-1}J_x)_x + (J^{-1}J_y)_y = 0,$$

where  $J$  is  $SU(2)$ -valued. Thus the  $J$ -matrix equation is the equation of the chiral model on  $\mathbb{M}^{2+1}$  with an extra ‘‘torsion term’’  $[J^{-1}J_x, J^{-1}J_t]$ . Ward calls this system the integrable chiral model. The chiral equation also has a stress-energy-momentum tensor satisfying a conservation law and in particular a conserved energy density. This energy is also a conserved quantity for the integrable chiral model because of the similarity of the equations. We shall describe this in detail in Section 4.1. Note also that, if we take the gauge group to be  $U(1)$ , the  $J$ -matrix equation reduces to the wave equation. For if  $J = e^{i\phi}$  then  $\phi$  satisfies the  $\mathbb{M}^{2+1}$  wave equation

$$-\phi_{tt} + \phi_{xx} + \phi_{yy} = 0.$$

Recall that the lift of  $X$  to  $\mathcal{P}$  is  $X' = \zeta\partial_\lambda + \partial_\mu$  and the reduced twistor space  $\mathcal{R}$  is  $T\mathbb{CP}^1$  with coordinates  $(\eta, \zeta)$ . The real structure  $\sigma = \sigma_3$  on  $\mathbb{CM}$  under which

the ultrahyperbolic space-time  $\mathbb{U}_1$  induces a real structure on  $\mathcal{P}$ . This in turn gives a real structure on  $\mathcal{R}$  given by  $\sigma((\eta, \zeta)) = (\bar{\eta}, \bar{\zeta})$ . The space-time points in  $\mathbb{M}^{2+1}$  correspond to real sections of the bundle  $T\mathbb{C}\mathbb{P}^1$ , i.e. those fixed by the real structure. The space-time point  $(x, y, t)$  corresponds to the section  $\eta = (x-t)\zeta^2 - 2y\zeta - (x+t)$ .

Solutions of the Bogomol'nyi equations correspond to bundles  $E'$  over  $\mathcal{R}$ . The condition that  $E'_{|_x}$  be trivial for points of  $\mathbb{U}_1$  corresponds to the condition that  $E'_{|_s}$  is trivial for all real sections  $s$ . If  $U$  and  $\tilde{U}$  are subsets of  $T\mathbb{C}\mathbb{P}^1$  covering the regions  $\{\text{Im}(\zeta) \geq 0\}$  and  $\{\text{Im}(\zeta) \leq 0\}$  and  $F$  is the corresponding patching matrix then  $F^\dagger = F$  where

$$F^\dagger(\eta, \zeta) \equiv F(\sigma(\eta, \zeta))^* = F(\bar{\eta}, \bar{\zeta})^*.$$

Thus we have the following:

**Theorem 3.1** *There is a 1-1 correspondence between:*

a) *Solutions of the Bogomol'nyi with gauge group  $SU(2)$  on  $\mathbb{M}^{2+1}$  (modulo gauge equivalence)*

and

b) *Rank-2 holomorphic vector bundles  $E'$  over  $T\mathbb{C}\mathbb{P}^1$  satisfying*

1.  *$E'_{|_s}$  is trivial for all real sections  $s$ ,*
2.  *$F^\dagger = F$  and*
3.  *$\det F = 1$ .*

Ward considered in [37] solutions which correspond to bundles over a compactification  $\bar{T}$  of  $T\mathbb{C}\mathbb{P}^1$  formed by adding a “section at infinity”. This can be constructed by considering the bundle  $\mathcal{O}(2) \oplus \mathcal{O}(0)$  and forming the projectivised bundle  $P(\mathcal{O}(2) \oplus \mathcal{O}(0))$  by taking the projective space of each fibre.

The condition that  $E'_{|_s}$  is trivial for real sections implies that we can split  $F$  as

$$F((x-t)\zeta^2 - 2y\zeta - (x+t), \zeta) = \tilde{H}H^{-1},$$

where  $H$  and  $\tilde{H}$  are invertible and holomorphic in  $\zeta$  on regions of the Riemann sphere containing  $\{\text{Im}(\zeta) \geq 0\}$  and  $\{\text{Im}(\zeta) \leq 0\}$  respectively. Since  $F$  depends only

on  $\zeta$  and  $\eta$  it follows that  $l(F) = 0$ ,  $m(F) = 0$ . And thus that

$$\tilde{H}^{-1}l(\tilde{H}) = H^{-1}l(H),$$

and a similar result for  $m$ . Since the two sides of this equation are holomorphic on the two halves of the Riemann sphere it follows by a Liouville-type argument that its value is of the form  $A + \zeta A'$  where  $A$ ,  $A'$  are independent of  $\zeta$ . This defines a gauge potential by putting

$$H^{-1}l(H) = A_x - A_t - \zeta(-A_y + \Phi)$$

and similarly for  $m$

$$H^{-1}m(H) = A_y + \Phi - \zeta(A_x + A_t).$$

With this connection and Higgs field,  $H^{-1}$  and  $\tilde{H}^{-1}$  are fundamental matrix solutions of the linear system.

Let us consider the geometry of the minitwistor space in more detail. First note that the real minitwistor space, i.e. that part of the Minitwistor space fixed by the real structure  $\sigma(\eta, \zeta) = (\bar{\eta}, \bar{\zeta})$  is topologically  $S^1 \times \mathbb{R}$ . It consists of the null 2-planes in  $\mathbb{M}^{2+1}$ . (Recall that a plane is null if the restriction of the metric to the plane is degenerate, or, equivalently, if the normal vector is null. To see this choose fixed real  $\zeta$  and  $\eta$  and put  $\zeta = \cot \frac{1}{2}\theta$ . Then the real minitwistor correspondence

$$\eta = (x - t)\zeta^2 - 2y\zeta - (x + t)$$

implies that  $x \cos \theta - y \sin \theta - t$  is constant and this represents a plane with null normal vector  $(\cos \theta, -\sin \theta, 1)$ . One could in fact start with the real twistor space and obtain  $\mathcal{T}$  as a complexification of it.

One might ask what the points of  $\mathcal{T}$  correspond to in  $\mathbb{M}^{2+1}$  under the minitwistor correspondence. If  $\eta$  and  $\zeta$  are real then of course this gives a null 2-plane. If  $\zeta$  is real and  $\eta$  complex then there are no solutions. If however  $\zeta$  is complex then the solution of the minitwistor correspondence are time-like geodesics, i.e. straight lines in time-like directions. The direction in coordinates  $(x, y, t)$  is  $(1 - |\zeta|^2, 2\text{Re}(\zeta), -(1 + |\zeta|^2))$ . Clearly  $(\eta, \zeta)$  and  $(\bar{\eta}, \bar{\zeta})$  determine the same line and thus remains fixed under the real structure. We think of those points with  $\text{Im}(\zeta) > 0$  representing future pointing



geodesics and  $\text{Im}(\zeta) < 0$  past-pointing ones and thus the real structure interchanges future and past pointing vectors.

Given two generic points in  $\mathbb{M}^{2+1}$ , the two corresponding sections will interact twice, with one point of intersection when the points are null-separated. When there are two points of intersection, the real structure will either interchange the two points, in which case the points are time-like separated or leaves them both fixed, in which case they are space-like separated.

## 3.2 Anti-deSitter Space-time

The constant curvature manifold with negative scalar curvature is anti-deSitter space-time. We shall first briefly describe  $(2 + 1)$ -dimensional anti-deSitter space-time and introduce some coordinates which will be useful later. More information, albeit about the  $(3 + 1)$ -dimensional case, can be found in [39]. The Bogomol'nyi equations in  $(2 + 1)$ -dimensional space-time were first described in [40].

Consider  $\mathbb{R}^4$  with coordinates  $(p, q, u, v)$  and metric  $dp^2 + dq^2 - du^2 - dv^2$ . Anti-deSitter space-time is the hyperboloid  $p^2 + q^2 - u^2 - v^2 = -1$  with the metric inherited from the ambient space. It is a constant curvature space-time, with scalar curvature  $-6$  (using the conventions of [39]). If one puts

$$p = \sinh \psi \cos \theta, \quad q = \sinh \psi \sin \theta, \quad u = \cosh \psi \cos \tau, \quad v = \cosh \psi \sin \tau,$$

then in these coordinates the metric becomes  $-\cosh^2 \psi d\tau^2 + d\psi^2 + \sinh^2 \psi d\theta^2$ . Topologically this is  $S^1 \times \mathbb{R}^2$  and so is not simply-connected. One often takes anti-deSitter space-time to be the universal covering space which is topologically  $\mathbb{R}^3$ , obtained by letting the  $\theta$  coordinate take all values in  $\mathbb{R}$ . Part of the space is covered by coordinates

$$p = \cos s \cosh \chi, \quad q = \cos s \sinh \chi \cos \theta, \quad u = \cos s \cosh \chi \sin \theta, \quad v = \sin s,$$

and in these coordinates the metric is

$$ds^2 + \cos^2 s (d\chi^2 + \sinh^2 \chi d\theta^2). \tag{3.1}$$

We shall work with the ‘‘Poincaré space-time’’

$$\{(x, r, t) \in \mathbb{R}^3 : r > 0\}$$

with metric

$$\frac{dx^2 + dr^2 - dt^2}{r^2}$$

and volume form  $r^{-3}dx \wedge dr \wedge dt$ , which is isometric to that part of anti-deSitter space-time above. We shall generally refer to this as anti-deSitter space-time,  $AdS^{2+1}$ .

The time-like geodesics in  $AdS^{2+1}$  are of the form

$$r = \frac{1}{\sqrt{T^2 - X^2}} \sec s, \quad x = \frac{X}{T^2 - X^2} \tan s + X_0, \quad t = \frac{T}{T^2 - X^2} \tan s + T_0,$$

where  $-\frac{1}{2}\pi < s < \frac{1}{2}\pi$  is proper time and  $|X| < T$ , or equivalently

$$r^2 + (x - X_0)^2 - (t - T_0)^2 = \frac{1}{T^2 - X^2}, \quad (x - X_0)T = (t - T_0)X.$$

In particular, if one puts  $r = R \sec s$ ,  $t = R \tan s$ ,  $R > 0$ , then  $x$ ,  $R$ ,  $s$  form coordinates for  $AdS^{2+1}$  in which the metric takes the form

$$-ds^2 + \cos^2 s \left( \frac{dx^2 + dR^2}{R^2} \right)$$

This last bracketed term is the metric for the familiar Poincaré half-plane, which is isometric to the Poincaré unit disc  $\{(X, Y) \in \mathbb{R}^2 : X^2 + Y^2 < 1\}$  with metric

$$\frac{4(dX^2 + dY^2)}{(1 - X^2 - Y^2)^2}.$$

Finally, if we take polar coordinates  $(\rho, \theta)$  on the unit disc and put  $\rho = \tanh(\chi/2)$  then we recover the metric (3.1) above.

The Bogomol’nyi equations  $D\Phi = -*F$  on  $AdS^{2+1}$  are

$$D_t\Phi = -rF_{xr}, \quad D_x\Phi = +rF_{rt}, \quad D_r\Phi = +rF_{tx}.$$

Solutions of these equations correspond to solutions of the ASDYM on the region of  $\mathbb{U}$

$$M = \{(x, y, t, u) \in \mathbb{U} : y > |u|\}$$

invariant under the 1-dimensional group of ‘‘Lorentz boosts’’ generated by  $X = y\partial_u + u\partial_y$ . If we put  $y = r \cosh \theta$ ,  $u = r \sinh \theta$ , the metric on  $M$  becomes  $dx^2 +$

$dr^2 - dt^2 - r^2 d\theta^2$ , and so  $M$  is conformally equivalent to the product of  $AdS^{2+1}$  and  $\mathbb{R}$  with metric

$$\frac{dx^2 + dr^2 - dt^2}{r^2} - d\theta^2. \quad (3.2)$$

In these coordinates the ASDYM equations are

$$F_{t\theta} = -rF_{xr}, \quad F_{x\theta} = +rF_{rt}, \quad F_{r\theta} = +rF_{tx}.$$

For solutions invariant under boosts  $\rho$  generated by  $X = \partial_\theta$ , in an invariant gauge,  $\rho^*A = A$ . This is equivalent to the components  $A_x$ ,  $A_t$ ,  $A_r$  and  $A_\theta$  of the gauge potential being independent of  $\theta$ . Putting  $A_\theta = \Phi$  gives the Bogomol'nyi equations on  $AdS^{2+1}$ .

In terms of double null coordinates we can take a neighbourhood  $U$  in  $\mathbb{CM}$  of the subset of  $\mathbb{U}_1$  with  $w - \tilde{w} > |w + \tilde{w}|$ , take coordinates

$$\begin{pmatrix} \tilde{z} & w \\ \tilde{w} & z \end{pmatrix} = \begin{pmatrix} x+t & re^\theta \\ -re^\theta & x-t \end{pmatrix},$$

and consider ASD connections on bundles  $E$  over  $U$  invariant under the group of conformal transformations generated by  $w\partial_w + \tilde{w}\partial_{\tilde{w}}$ . With these coordinates the usual volume form is  $-r dx \wedge dr \wedge dt \wedge d\theta$ . So in fact with these conventions ASD connections on  $U$  correspond to SD connections on  $M$  and, if invariant under  $\partial_\theta$ , solutions of  $D\Phi = *F$ .

The lift of the action of  $H$  to  $\mathcal{F}$  is generated by  $X'' = w\partial_w + \tilde{w}\partial_{\tilde{w}} - \zeta\partial_\zeta$ , i.e.  $\partial_\theta - \zeta\partial_\zeta$ . The invariance condition implies that one can find sections of the bundle  $E''$  over the pullback of  $U$  to correspondence space which satisfy  $\mathcal{L}_{X''}s = 0$  as well as  $Ls = 0$  and  $Ms = 0$ . The quantity  $\sigma = \zeta e^\theta$  is an invariant spectral parameter, as are  $\lambda = r\sigma + x + t$  and  $\omega = -r/\sigma^{-1} + x - t$ . The quantities  $x$ ,  $r$ ,  $t$  and  $\sigma$  form coordinates on the reduced correspondence space, i.e. the quotient of  $\mathcal{F}$  under  $X''$ .

The Lax pair becomes

$$\begin{aligned} Ls &= \left( D_r + \frac{1}{ir}\Phi + \frac{\sigma}{r}\partial_\sigma - \sigma(D_x + D_t) \right) s \\ Ms &= \left( (D_x - D_t) - \sigma(-D_r + \frac{1}{ir}\Phi + \frac{\sigma}{r}\partial_\sigma) \right) s \end{aligned}$$

where  $s$  is a function of  $\sigma$  ( as well as  $x, r, t$ ). If we take coordinates  $x, r, t$  and  $\lambda$  then the Lax pair becomes

$$\begin{aligned} Ls &= \left( D_r + \frac{1}{r}\Phi - \frac{(\lambda - (x+t))}{r}(D_x + D_t) \right) s \\ Ms &= \left( (D_x - D_t) - \frac{(\lambda - (x+t))}{r}(-D_r + \frac{1}{r}\Phi) \right) s. \end{aligned}$$

This second Lax pair first appeared in [40].

If  $f(\lambda)$  is a fundamental matrix solution of the linear system, the gauge potential and Higgs field are given by

$$\begin{aligned} A_r + \frac{1}{r}\Phi - \frac{(\lambda - (x+t))}{r}(A_x - A_t) &= -l(f)f^{-1}, \\ A_x - A_t - \frac{(\lambda - (x+t))}{r}(-A_r + \frac{1}{r}\Phi) &= -m(f)f^{-1}, \end{aligned}$$

where

$$\begin{aligned} l &= \partial_r - \frac{(\lambda - (x+t))}{r}(\partial_x + \partial_t), \\ m &= (\partial_x - \partial_t) + \frac{(\lambda - (x+t))}{r}\partial_r. \end{aligned}$$

The real structure  $\sigma_3$  on  $\mathbb{CM}$ , which fixes the real slice  $\mathbb{U}_1$ , induces a real structure on the correspondence space which takes  $\sigma$  to  $\bar{\sigma}$  and  $\lambda$  to  $\bar{\lambda}$ . Thus the reality condition

$$f(x, r, t, \bar{\lambda})^* = f(x, r, t, \lambda)^{-1}$$

for real  $x, r$  and  $t$  gives  $\mathfrak{su}(2)$ -valued gauge potential and Higgs field (with a similar result for  $\sigma$ ). One can define a  $J$ -matrix by  $J = \tilde{h}^{-1}h$ , where  $h$  and  $\tilde{h}$  satisfy

$$\left( D_r + \frac{1}{r}\Phi \right) h = 0, \quad (D_x - D_t)h = 0$$

and

$$(D_x + D_t)\tilde{h} = 0 \quad \left( -D_r + \frac{1}{r}\Phi \right) \tilde{h} = 0,$$

respectively. The  $J$ -matrix satisfies

$$-(J^{-1}J_t)_t + (J^{-1}J_x)_x + (J^{-1}J_r)_r + \frac{1}{r}(J^{-1}J_r) + [J^{-1}J_x, J^{-1}J_t] = 0.$$

In a gauge in which  $A_r = -\Phi/r$  and  $A_x = A_t$

$$\begin{aligned} A_x = A_t &= \frac{1}{2}J^{-1}J_x + \frac{1}{2}J^{-1}J_t, \\ A_r = -\Phi/r &= \frac{1}{2}J^{-1}J_r. \end{aligned}$$

When  $J$  is  $SU(2)$ -valued this give  $\mathfrak{su}(2)$ -valued solutions.

We might expect the  $J$ -matrix equation on  $AdS^{2+1}$  to be the chiral equation on  $AdS^{2+1}$  plus a torsion term as for the Minkowski space-time. The chiral equation is defined as

$$\nabla^\mu (J^{-1} \nabla_\mu J) = 0,$$

where  $\nabla$  is the Levi-Civita connection. Recall that the action of  $\nabla$  on a vector field  $v$  is given by

$$\nabla_\mu v^\nu = \partial_\mu v^\nu + \Gamma^\nu_{\mu\lambda} v^\lambda, \quad (3.3)$$

where the  $\Gamma$  are the connection coefficients. The non-zero coefficients for anti-deSitter space-time are

$$\Gamma^t_{tr} = \Gamma^t_{rt} = \Gamma^x_{xr} = \Gamma^x_{rx} = \Gamma^r_{rr} = \Gamma^r_{tt} = -\Gamma^r_{xx} = -r^{-1}. \quad (3.4)$$

So the chiral equation on  $AdS^{2+1}$  is

$$-(J^{-1} J_t)_t + (J^{-1} J_x)_x + (J^{-1} J_r)_r - \frac{1}{r} (J^{-1} J_r) = 0,$$

which is not the  $J$ -matrix equation without torsion.

The reason is due to the fact that the region  $M$  is only *conformally equivalent* to  $AdS^{2+1} \times \mathbb{R}$ . In the case of the ASDYM equations, the equations are conformally invariant, so solutions of the equations on  $M$  correspond to solutions on  $AdS^{2+1} \times \mathbb{R}$ , and  $\theta$ -invariant solutions correspond to solutions of the Bogomol'nyi equations on  $AdS^{2+1}$ . For the  $J$ -matrix on  $AdS^{2+1}$  defined above, the  $J$ -matrix equation is actually the  $\theta$ -invariant  $J$ -matrix equation on  $M$ , which is the  $\theta$ -invariant chiral equation on  $M$  plus torsion terms. However this is not the  $AdS^{2+1}$  chiral equation plus torsion terms because it is not conformally invariant.

In particular, consider the special case when the gauge group is  $U(1)$ .  $J$  is  $U(1)$ -valued and we can write  $J = e^{i\phi}$ . The  $J$ -matrix equation then reduces to

$$-\phi_{tt} + \phi_{xx} + \phi_{rr} + \frac{1}{r} \phi_r = 0. \quad (3.5)$$

The  $J$ -matrix equation in  $(2+2)$ -dimensions reduces in the  $U(1)$  case to the ultra-hyperbolic wave equation, which in coordinates  $(x, r, t, \theta)$  is

$$-\phi_{tt} + \phi_{xx} + \phi_{rr} + \frac{1}{r} \phi_r - \frac{1}{r^2} \phi_{\theta\theta} = 0, \quad (3.6)$$

so (3.5) is just the  $\theta$ -invariant version of (3.6). On the other hand the  $AdS^{2+1}$  chiral equation reduces to the  $AdS^{2+1}$  wave equation

$$-\phi_{tt} + \phi_{xx} + \phi_{rr} - \frac{1}{r}\phi_r = 0.$$

So the  $J$ -matrix equation is not the  $AdS^{2+1}$  wave equation as one might have expected. Again this is because the region  $M$  of  $\mathbb{U}$  is only conformally equivalent to the product of  $AdS^{2+1}$  and  $\mathbb{R}$ , and the ultrahyperbolic wave equation is not conformally invariant. However there is a conformally invariant version of the ultrahyperbolic wave equation, obtained by adding a term  $-\frac{1}{6}R\phi$ , which is conformally invariant with conformal weight  $-1$ . (Recall an equation is said to be conformally invariant with weight  $s$  if, whenever  $\phi$  is a solution of the equation for the metric  $g$ ,  $\hat{\phi} = \Omega^s\phi$  is a solution for the metric  $\Omega^2g$ ). If we take a solution  $\phi$  of the wave equation on  $M$ , then  $\hat{\phi} = r\phi$  satisfies the conformally invariant wave equation on the space with metric (3.2). If  $\phi$  (and so  $\hat{\phi}$ ) is invariant under  $\partial_\theta$ , then  $\hat{\phi}$  satisfies the equation

$$r^2(-\hat{\phi}_{tt} + \hat{\phi}_{xx} + \hat{\phi}_{rr} - \frac{1}{r}\hat{\phi}_r) + \hat{\phi} = 0,$$

which is the wave equation plus the term  $\hat{\phi} = -\frac{1}{6}R\hat{\phi}$ .

Recall that the action of  $X$  on  $U \subseteq \mathbb{CM}$  induces an action on  $\mathcal{P}$  generated by  $X' = -\mu\partial_\mu - \zeta\partial_\zeta$ . Then  $\lambda$  and  $\omega = \mu/\zeta$  are coordinates on reduced twistor space. If  $U$  contains all of  $\mathbb{U}_1$ , then the reduced twistor space  $\mathcal{R}$  is  $\mathbb{CP}^1 \times \mathbb{CP}^1$ , covered by four coordinate patches with coordinates  $(\lambda, \omega)$ ,  $(\lambda, \omega^{-1})$ ,  $(\lambda^{-1}, \omega)$  and  $(\lambda^{-1}, \omega^{-1})$  for the four cases. Since  $M$  is only part of  $\mathbb{U}_1$ , if  $U$  is sufficiently small then  $\mathcal{R}$  could be part of  $\mathbb{CP}^1 \times \mathbb{CP}^1$ , however it will certainly contain the region where the imaginary parts of  $\lambda$  and  $\omega$  have the same sign as can be seen by taking imaginary part in the the minitwistor correspondence for real space-time points. Again, as for the Minkowski space-time case, the real structure  $\sigma_3$  on  $\mathcal{P}$ , described previously, gives rise to a real structure on  $\mathcal{R}$ , this time given by  $\sigma(\lambda, \omega) = (\bar{\lambda}, \bar{\omega})$ .

Solutions of the Bogomol'nyi equations on  $AdS^{2+1}$  correspond to bundles over  $\mathcal{R}$ . Recall from Section 2.3 that the lines  $\hat{p}$  in  $\mathcal{P}$  correspond to curves in  $\mathcal{R}$  of the form

$$\omega = z - \frac{r^2}{\lambda - \bar{z}}$$

and from Section 2.4 that these curves are special, as defined in that section. The triviality condition is here that  $E'_s$  is trivial, where  $s$  is a special curve which is real in the sense that it is fixed by the real structure, i.e. a curve of the form

$$\omega = x - t - \frac{r^2}{\lambda - (x + t)},$$

for  $x, t, r$  real,  $r > 0$ .

The reality condition is that the patching matrix of bundle satisfies

$$F^\dagger(\lambda, \omega) \equiv F(\bar{\lambda}, \bar{\omega})^* = F(\lambda, \omega).$$

Thus we have the following

**Theorem 3.2** *There is a 1-1 correspondence between:*

a) *Solutions of the Bogomol'nyi with gauge group  $SU(2)$  on  $AdS^{2+1}$  (modulo gauge equivalence)*

*and*

b) *Rank-2 holomorphic vector bundles  $E'$  over  $\mathcal{R}$  satisfying*

1.  $E'_s$  *is trivial for all real special curves  $s$*
2.  $F^\dagger = F$ , *and*
3.  $\det F = 1$ .

We shall construct examples of these bundles in Section 3.5.

Again let us consider the geometry of the minitwistor space in more detail as we did for Minkowski space-time. First the real minitwistor space, i.e. that part fixed by the real structure  $\sigma(\lambda, \omega) = (\bar{\lambda}, \bar{\omega})$  is  $\mathbb{R}\mathbb{P}^1 \times \mathbb{R}\mathbb{P}^1$ . It consists of the totally geodesic, null, hypersurface in  $AdS^{2+1}$ . One could in fact again start with the real minitwistor space and obtain  $\mathcal{T}$  as a complexification of it.

Suppose  $\lambda$  and  $\omega$  have non-zero imaginary parts which are of the same sign. Then the set of real points on the curve is a time-like geodesic. Specifically if the imaginary parts are positive and one puts

$$\lambda = X_0 + T_0 + \frac{1}{T - X}i, \quad \omega = X_0 - T_0 + \frac{1}{T + X}i,$$

then the real points correspond to the time-like geodesic.

$$r^2 = (x - X_0)^2 - (t - T_0)^2 = \frac{1}{T^2 - X^2}, \quad (x - X_0)Y = (y - Y_0)X.$$

If  $\lambda$  and  $\omega$  have the opposite sign then they determine the same geodesic. As for the Minkowski space-time case we regard the geodesics as being future-pointing when  $\text{Im}(\lambda) > 0$ , and past-pointing when  $\text{Im}(\lambda) < 0$ . Clearly with this definition the real structure interchanges future-pointing and past-pointing geodesics.

Two generic special curves intersect in two points in minitwistor space, with one point of intersection when the points are null-separated. When we consider real space-time points, then as in the Minkowski case the points are interchanged by the real structure if they are time-like-separated and left fixed if they are space-like separated. To see this consider, without loss of generality, space-time points  $(x_0, r_0, t_0)$  and  $(0, a, 0)$ . To find the points of intersection one solves a quadratic equation in  $\lambda$ . The roots are

$$\lambda = \frac{(x^2 - t^2 + r^2 - a^2) \pm \sqrt{(x^2 - t^2 + r^2 - a^2)^2 + 4a^2(x^2 - t^2)}}{(x - t)}.$$

This discriminant is negative for time-like-separated points and positive for space-like-separated points. If we consider a space-like curve

$$r = \frac{1}{\sqrt{T^2 - X^2}} \sec s, \quad x = \frac{X}{T^2 - X^2} \tan s, \quad t = \frac{T}{T^2 - X^2} \tan s,$$

with  $T^2 - X^2 = a^{-1}$ , then the discriminant is  $-4a^4 \tan^2 s$  for all points on the curve.

If on the other hand we consider a space-like curve

$$r = \frac{1}{\sqrt{X^2 - T^2}} \text{sech } s, \quad x = \frac{X}{X^2 - T^2} \tanh s, \quad t = \frac{T}{X^2 - T^2} \tanh s,$$

with  $X^2 - T^2 = a^{-1}$ , then the discriminant is  $4a^4 \tanh^2 s$  for all points on the curve.

### 3.3 deSitter Space-time

The standard example of a constant curvature manifold with positive scalar curvature is deSitter space-time. We shall briefly describe the  $(2 + 1)$ -dimensional version here. There is a more detailed discussion of the  $(3 + 1)$ -dimensional version in [39].



Consider  $\mathbb{R}^4$  with coordinates  $(p, u, v, w)$  and metric  $-dp^2 + du^2 + dv^2 + dw^2$  and define  $(2+1)$ -dimensional deSitter space-time to be the hyperboloid  $-p^2 + u^2 + v^2 + w^2 = 1$  with metric induced from the ambient space. This is a  $(2+1)$ -dimensional manifold with constant curvature and scalar curvature  $+6$ . If one takes coordinates on the hyperboloid

$$p = \sinh T, \quad u = \cosh T \cos \chi, \quad v = \cosh T \sin \chi \cos \theta, \quad w = \cosh T \sin \chi \sin \theta,$$

then in these coordinates the metric becomes

$$ds^2 = -dT^2 + \cosh^2 T(d\chi^2 + \cos^2 \chi d\theta^2).$$

The region of space-time corresponding to  $\cos \chi > -\tanh T$  is isometric to the ‘‘Poincaré’’ space-time  $\{(x, y, t) : t > 0\}$  with metric

$$\frac{dx^2 + dy^2 - dt^2}{t^2}.$$

To see this define coordinates by

$$\begin{aligned} t^{-1} &= \cosh T \cos \chi + \sinh T, \\ xt^{-1} &= \cosh T \sin \chi \cos \theta, \\ yt^{-1} &= \cosh T \sin \chi \sin \theta. \end{aligned}$$

Again we shall consider this Poincaré space-time rather than the full deSitter space-time and refer to this as deSitter space-time  $dS^{2+1}$ . It has time-like geodesics

$$x = \frac{X}{X^2 + Y^2} \coth s + X_0, \quad y = \frac{Y}{X^2 + Y^2} \coth s + Y_0, \quad t = \frac{1}{\sqrt{X^2 + Y^2}} \operatorname{cosech} s,$$

or equivalently

$$(x - X_0)^2 + (y - Y_0)^2 = \frac{1}{X^2 + Y^2} + t^2, \quad (x - X_0)y = (y - Y_0)x$$

for real constants  $X, Y, X_0, Y_0$  with  $X$  and  $Y$  not both zero, where  $s$  is proper time.

If we equip  $dS^{2+1}$  with the volume form  $t^{-3}dx \wedge dy \wedge dt$  then the Bogomol’nyi equations corresponding to  $D\Phi = -*F$  are

$$D_t \Phi = -tF_{xy}, \quad D_x \Phi = +rF_{yt}, \quad D_y \Phi = +tF_{tx}.$$

Solutions of these correspond to solutions of the ASDYM equations in  $(2 + 2)$ -dimensions invariant under a 1-dimensional group of “rotations”. Let  $\mathbb{U}$  be  $\mathbb{R}^4$  with coordinates  $(x, y, u, v)$  metric  $dx^2 + dy^2 - du^2 - dv^2$  and consider the region

$$M = \{(x, y, u, v) : u^2 + v^2 > 0\}.$$

If we put  $u = t \cos \theta$  and  $v = t \sin \theta$  the metric becomes  $dx^2 + dy^2 - dt^2 - t^2 d\theta^2$  which is conformally equivalent to the product of  $dS^{2+1}$  and  $\mathbb{R}$ . In these coordinates the ASDYM equations are

$$F_{t\theta} = -tF_{xy}, \quad F_{x\theta} = +tF_{yt}, \quad F_{y\theta} = +tF_{tx}.$$

Imposing invariance under  $\theta$  gives the Bogomol’nyi equations.

In terms of double-null coordinates we can take a neighbourhood  $U$  in  $\mathbb{CM}$  of the subset of the real slice  $\mathbb{U}_2$  with  $w$  and  $\tilde{w}$  not both zero and take coordinates

$$\begin{pmatrix} \tilde{z} & w \\ \tilde{w} & z \end{pmatrix} = \begin{pmatrix} x + iy & te^{i\theta} \\ te^{-i\theta} & x - iy \end{pmatrix}.$$

ASD connections on bundles  $E$  over  $U$  which are invariant under the group of transformations generated by  $X = i(w\partial_w - \tilde{w}\partial_{\tilde{w}})$  correspond to solutions of the Bogomol’nyi equations in  $dS^{2+1}$ . With these coordinates the usual volume form on  $\mathbb{CM}$  is  $+t dx \wedge dy \wedge dt \wedge d\theta$  and so this time ASD connections correspond to solutions of  $D\Phi = -*F$  rather than  $D\Phi = *F$ .

The lift  $X''$  of  $X$  to the correspondence space  $\mathcal{F}$  is  $i(w\partial_w - \tilde{w}\partial_{\tilde{w}} - \zeta\partial_\zeta)$ . The invariance condition implies that one can find sections of the bundle  $E''$  over  $\mathcal{F}$  which satisfy  $\mathcal{L}_{X''}s = 0$  as well as  $Ls = 0$ ,  $Ms = 0$ . Exactly the same issues arise with the choice of lift of the action arise as in the hyperbolic case.

The quantity  $\sigma = \zeta e^{i\theta}$  is an invariant spectral parameter as are  $\lambda = t\sigma + (x + iy)$  and  $\omega = t/\sigma + (x - iy)$ . The quantities  $x, y, t$  and  $\sigma$  form coordinates on the reduced correspondence space, i.e. the quotient of  $\mathcal{F}$  under  $X''$ . The Lax pair becomes

$$\begin{aligned} Ls &= \left( D_t + \frac{1}{it}\Phi + \frac{\sigma}{t}\partial_\sigma - \sigma(D_x - iD_y) \right) s(\sigma), \\ Ms &= \left( (D_x + iD_y) - \sigma(D_t - \frac{1}{it}\Phi - \frac{\sigma}{t}\partial_\sigma) \right) s(\sigma), \end{aligned}$$

where  $s$  is a function of  $\sigma$  (as well as  $x, y, t$ ). If we take coordinates  $x, y, t$  and  $\lambda$  then the Lax pair becomes

$$\begin{aligned} Ls &= \left( D_t + \frac{1}{it}\Phi - \frac{(\lambda - (x + iy))}{r}(D_x - iD_y) \right) s(\lambda), \\ Ms &= \left( (D_x + iD_y) - \frac{(\lambda - (x + iy))}{t}(D_t - \frac{1}{it}\Phi) \right) s(\lambda). \end{aligned}$$

If  $f(\lambda)$  is a fundamental matrix solution of the linear system, the gauge potential and Higgs field are given by

$$\begin{aligned} A_t + \frac{1}{it}\Phi - \frac{(\lambda - (x + iy))}{t}(A_x - iA_y) &= -l(f)f^{-1}, \\ A_x + iA_t - \frac{(\lambda - (x + iy))}{t}(A_t - \frac{1}{it}\Phi) &= -m(f)f^{-1}, \end{aligned}$$

where

$$\begin{aligned} l &= \partial_t - \frac{(\lambda - (x + iy))}{t}(\partial_x - i\partial_y), \\ m &= (\partial_x + i\partial_y) + \frac{(\lambda - (x + iy))}{t}\partial_t, \end{aligned}$$

with a similar result using  $\sigma$  as the spectral parameter. The real structure  $\sigma_4$  on  $\mathbb{CM}$  which fixes the real slice  $\mathbb{U}_2$  induces a real structure on the correspondence space which takes  $\sigma$  to  $\bar{\sigma}^{-1}$ . Thus the reality condition is

$$f(x, r, t, \bar{\sigma}^{-1})^* = f(x, r, t, \sigma)^{-1},$$

and this gives  $\mathfrak{su}(2)$ -valued gauge potential and Higgs field. The condition for fundamental solutions  $f(\lambda)$  is more complicated since

$$(x, y, t, \lambda) \longrightarrow (\bar{x}, \bar{y}, \bar{t}, \bar{z} + \bar{t}^2/(\bar{\lambda} - \bar{z})).$$

One can define a  $J$ -matrix by  $J = \tilde{h}^{-1}h$ , where  $h$  and  $\tilde{h}$  satisfy

$$\left( D_t + \frac{1}{it}\Phi \right) h = 0, \quad (D_x + iD_y)h = 0$$

and

$$(D_x - iD_y)\tilde{h} = 0 \quad \left( D_t - \frac{1}{it}\Phi \right) \tilde{h} = 0,$$

respectively. The  $J$ -matrix satisfies

$$-(J^{-1}J_t)_t - \frac{1}{t}(J^{-1}J_t) + (J^{-1}J_x)_x + (J^{-1}J_y)_y - i[J^{-1}J_x, J^{-1}J_y] = 0.$$

In a gauge in which  $A_t = \Phi/it$  and  $A_x = iA_y$

$$\begin{aligned} A_x = iA_y &= \frac{1}{2}J^{-1}J_x - i\frac{1}{2}J^{-1}J_y \\ A_t = \Phi/(it) &= \frac{1}{2}J^{-1}J_t. \end{aligned}$$

When the gauge group is  $G = U(1)$  the  $J$ -matrix equation reduces to

$$-\phi_{tt} - \frac{1}{t}\phi_t + \phi_{xx} + \phi_{yy} = 0$$

which is again not the wave equation on  $dS^{2+1}$ , for the same reasons as for  $AdS^{2+1}$

The action on  $\mathcal{P}$  induced by  $X$  is generated by  $X' = -\mu\partial_\mu - \zeta\partial_\zeta$  and the reduced twistor space (minitwistor space) is  $\mathbb{CP}^1 \times \mathbb{CP}^1$  and  $\lambda$  and  $\omega$  are coordinates. The real structure  $\sigma_4$  on  $\mathbb{CM}$  of course induces a real structure on  $\mathcal{P}$  and so induces a real structure on the reduced twistor space given by

$$\sigma_4(\lambda, \omega) = (\bar{\omega}, \bar{\lambda}).$$

Solutions of the Bogomol'nyi equations on  $dS^{2+1}$  correspond to bundles over  $\mathcal{R}$ . The triviality condition is here that  $E'_{|_s}$  is trivial where  $s$  is a ‘‘special curve’’ which is real in the sense that it is fixed  $\sigma_4$ , i.e. a curve of the form

$$\omega = x - iy + t^2/(\lambda - (x + iy))$$

for  $x, y, t$  real. The reality condition is that the patching matrix  $F$  is equivalent to

$$F^\dagger(\lambda, \omega) \equiv F(\bar{\lambda}, \bar{\omega})^* = F(\lambda, \omega)$$

where  $*$  denotes hermitian conjugation.

The real minitwistor space is that part of the minitwistor space fixed by the real structure and consists of totally geodesic, null hypersurfaces. It corresponds to the set of points  $(\lambda, \omega)$  with  $\lambda = \bar{\omega}$  and so can be identified with  $S^2$ .

Other points in the minitwistor space correspond to time-like geodesics. If  $\lambda \neq \bar{\omega}$  and one puts

$$\lambda = X_0 + iY_0 + \frac{1}{X - iY}i, \quad \omega = X_0 - iY_0 + \frac{1}{X + iY}i,$$

then the real points correspond to the time-like geodesic.

$$(x - X_0)^2 + (y - Y_0)^2 = \frac{1}{X^2 + Y^2} + t^2, \quad (x - X_0)Y = (y - Y_0)X.$$

If  $\lambda$  and  $\omega$  have the opposite sign then they determine the same geodesic. As for the Minkowski space-time case we regard the geodesics as being future-pointing when  $\text{Im}(\lambda) > 0$ , and past-pointing when  $\text{Im}(\lambda) < 0$ . Clearly the real structure interchanges these geodesics.

Again as for the Minkowski and anti-deSitter spaces the special curves corresponding to two space-time points intersect in two points in minitwistor which are interchanged by the real structure when time-like-separated and fixed by when space-like separated.

### 3.4 Solutions for ADS Space-time

In this section we shall construct explicit soliton solutions of the Bogomol'nyi equations on anti-deSitter space-time, with gauge group  $SU(2)$ , using a method due to Zakharov and Shabat [41, 42] and used by Ward in the Minkowski space-time case [35]. The ASDYM equations imply we can take a gauge in which  $A_r = r^{-1}\Phi$  and  $A_x = -A_t$ . If  $\psi(\lambda)$  is a fundamental matrix solution of the linear system

$$L\psi = \left( D_r + \frac{1}{r}\Phi - \frac{(\lambda - (x+t))}{r}(D_x + D_t) \right) \psi, \quad (3.7)$$

$$M\psi = \left( (D_x - D_t) - \frac{(\lambda - (x+t))}{r}(-D_r + \frac{1}{r}\Phi) \right) \psi, \quad (3.8)$$

then we recover the gauge potential and Higgs field from the linear system

$$A_r = r^{-1}\Phi = -\frac{1}{2}(\partial_r + \frac{(x+t)}{r}(\partial_x + \partial_t))\psi(0)\psi(0)^{-1}, \quad (3.9)$$

$$A_x = -A_t = -\frac{1}{2}(\partial_x - \partial_t - \frac{(x+t)}{r}(\partial_r))\psi(0)\psi(0)^{-1}, \quad (3.10)$$

and in particular,

$$\Phi = -(r\partial_r + (x+t)(\partial_x + \partial_t))\psi(0)\psi(0)^{-1}. \quad (3.11)$$

We shall impose the reality condition described in Section 3.2, namely

$$\psi(x, r, t, \bar{\lambda})^* = \psi(x, r, t, \lambda)^{-1}, \quad (3.12)$$

where we have used  $*$  to denote hermitian conjugation. In particular  $\psi(0)$  is unitary, and hence the gauge potential and Higgs field take values in  $\mathfrak{su}(2)$ .

To obtain soliton solutions, we assume  $\psi$  has the form

$$\psi_{ab} = \delta_{ab} + \sum_{k=1}^N (\lambda - \mu_k)^{-1} n_a^k m_b^k, \quad (3.13)$$

for some  $N$ , where  $a = 1, 2$ ,  $b = 1, 2$  label the rows and columns of  $\psi$  respectively. Here  $\mu_1 \dots \mu_n$  are constants with non-zero imaginary part and the  $n_a^k$  and  $m_b^k$  are functions of  $r$ ,  $x$  and  $t$ , but not  $\lambda$ .

The reality condition (3.12) implies that the quantity  $\psi(\lambda)\psi(\bar{\lambda})^*$  is the identity, and hence it has only removable singularities, which is the case if and only if

$$n_a^k = \sum_{l=1}^2 (\Gamma^{-1})^{kl} \bar{m}_a^l, \quad (3.14)$$

where

$$\Gamma^{kl} = \sum_{a=1}^2 (\bar{\mu}_k - \mu_l)^{-1} \bar{m}_a^k m_a^l. \quad (3.15)$$

For  $A_x$ ,  $A_r$ ,  $A_t$  and  $\Phi$  to satisfy the linear system (3.7), (3.8) and be independent of  $\lambda$  we require the apparent poles in (3.7) and (3.8) to be removable. This imposes differential equations on the functions  $m_a^k$  and these satisfied when they depend on  $x$ ,  $r$  and  $t$  only through the combination

$$\omega_k = x - t - \frac{r^2}{\mu_k - (x + t)} \quad (3.16)$$

which is annihilated by the operators

$$l_k = \partial_r + \frac{(x + t)}{r} (\partial_x + \partial_t) - \mu_k (\partial_x + \partial_t),$$

and

$$m_k = \partial_x - \partial_t - \frac{(x + t)}{r} \partial_r + \mu_k \frac{1}{r} \partial_r.$$

If  $c$  is an arbitrary function of the space-time variables then replacing  $(m_1^k, m_2^k)$  by  $(cm_1^k, cm_2^k)$  determines the same function  $\psi$ . Thus we shall assume  $(m_1^k, m_2^k) = (1, f_k)$  for some function  $f_k$  of  $\omega_k$ .

We shall assume further that  $f_k$  are rational functions of  $\omega_k$ . This is by analogy with the Minkowski space-time case, where choosing  $f_k$  to be rational gives a smooth solution satisfying certain boundary conditions. In particular the conserved “energy” for the  $J$ -matrix equation is finite for  $f_k$  rational (see [35]). Assuming all the functions  $f_k$  have degree 1, this gives an  $8N$ -parameter family of solutions of the linear system (3.7), (3.8) —  $N$  complex parameters  $\mu_k$  and  $3N$  complex parameters determining  $f_k$  — and hence an  $(8N - 3)$ -parameter family of solutions of the Bogomol’nyi equations, taking into account a global  $SU(2)$  factor.

One can obtain solutions of the  $J$ -matrix by re-writing  $\psi(\lambda)$  as a function of  $\sigma$  and putting  $h = \psi(\sigma=0)$ ,  $\tilde{h} = \psi(\sigma=\infty)$  — in other words by putting  $h = \psi(\lambda=(x+t))$  and  $\tilde{h} = \psi(\lambda=\infty) = \text{id}$ .

### 3.5 Bundles for ADS Space-time

We showed that real-analytic  $SU(2)$  Yang-Mills-Higgs solitons on the Poincaré space correspond to holomorphic vector bundles over the reduced twistor space  $\mathcal{R}$ , an open subset of  $\mathbb{CP}^1 \times \mathbb{CP}^1$  which contains the real twistor space  $\mathbb{RP}^1 \times \mathbb{RP}^1$ , subject to certain conditions which reduce the gauge group from  $GL(2, \mathbb{C})$  to  $SU(2)$  and a triviality condition which allow the patching matrix to be split. In this section we shall construct the holomorphic bundles corresponding to the 5-parameter family of 1-solitons found in Section 3.4. In this case the solutions of the linear problem are defined and holomorphic on the whole of  $\mathbb{CM}$  (or more correctly on its correspondence space) and so give holomorphic vector bundles over the whole of  $\mathbb{CP}^1 \times \mathbb{CP}^1$ .

In terms of local coordinates, we cover  $\mathcal{R}$  by four (or more) charts. A bundle  $E'$  over  $\mathcal{R}$  is defined in terms of patching matrices  $F = F(\lambda, \omega)$  such that for all points  $(x, r, t)$  in the Poincaré space there exist matrices  $H(\lambda)$  and  $\tilde{H}(\lambda)$ , holomorphic on the the halves of the Riemann sphere  $\{\lambda : \text{Im}(\lambda) \geq 0\}$ ,  $\{\lambda : \text{Im}(\lambda) \leq 0\}$ , satisfying

$$F\left(\lambda, x - t - \frac{r^2}{\lambda - (x+t)}\right) = \tilde{H}(\lambda)H(\lambda)^{-1}, \quad (3.17)$$

and such that

$$\det(F) = 1, \quad (3.18)$$

$$F^\dagger = F \tag{3.19}$$

where

$$F^\dagger(\lambda, \omega) = F(\bar{\lambda}, \bar{\omega}). \tag{3.20}$$

Now since the transition matrices depend only on the twistor variables  $\lambda$  and  $\omega$ ,  $l(F) = 0$  and  $m(F) = 0$ , where  $l = (\partial_r + r^{-1}(x+t)(\partial_x + \partial_t)) - \lambda(\partial_x + \partial_t)$  and  $m = (\partial_x - \partial_t - r^{-1}(x+t)\partial_r) + \lambda r^{-1}\partial_r$  and thus

$$H^{-1}l(H) = \tilde{H}^{-1}l(\tilde{H}). \tag{3.21}$$

The left-hand side is holomorphic for  $\text{Im}(\lambda) \geq 0$  and the right for  $\text{Im}(\lambda) \leq 0$ . Thus by a Liouville-type argument the quantity is of the form  $A + \lambda A'$ , for functions  $A, A'$  of  $x, r$  and  $t$  but not  $\lambda$ . Similarly  $H^{-1}m(H)$  is of the form  $B + \lambda B'$  for functions  $B, B'$  independent of  $\lambda$ . If we put  $A = A_r + r^{-1}\Phi$ ,  $A' = A_x + A_t$ ,  $B = A_x - A_t$  and  $B' = -A_r + r^{-1}\Phi$  then  $A_\mu$  and  $\Phi$  satisfy the Bogomol'nyi equation on  $AdS^{2+1}$ . By an appropriate gauge choice  $A', B'$  can be set to zero.

The patching matrices then satisfy

$$D_l(H^{-1}) = 0, \quad D_l(\tilde{H}^{-1}) = 0, \tag{3.22}$$

where  $D_l = l + A$ , and a similar pair of equations for  $m$ . Thus  $H^{-1}$  and  $\tilde{H}^{-1}$  are fundamental matrix solutions. However the singularity structure of these solutions is different from that of the solutions of the previous section. For  $\text{Im}(\lambda) \geq 0$ , the splitting matrix  $H$  is invertible and has no singularities. Similarly for  $\text{Im}(\lambda) \leq 0$ , the splitting matrix  $\tilde{H}$  is invertible with no singularities. However the 1-soliton fundamental solution of Section 3.4 has a singularity at  $\lambda = \mu_1$  and is non-invertible at  $\lambda = \bar{\mu}_1$ . We can, though, use our fundamental solution  $\psi$  to find splitting matrices  $H, \tilde{H}$ . Since  $\psi$  and  $H^{-1}$  are annihilated by  $D_l$  and  $D_m$  it follows that  $l(K) = m(K) = 0$ , where  $K = H\psi$ . Thus  $H = K\psi^{-1}$  where  $K$  is a matrix-valued function depending on  $x, r$  and  $t$  only through the twistor variables  $\lambda$  and  $\omega$ . Similarly  $\tilde{K} = \tilde{H}\psi$  depends on  $\lambda$  and  $\omega$  only. So to find a patching matrix for the bundle corresponding to our fundamental solution  $\psi$  we need to find a matrices  $K$  and  $\tilde{K}$ , holomorphic in  $\lambda$  and  $\omega$ , such that  $K\psi^{-1}$  is defined and invertible for  $\text{Im}(\lambda) \geq 0$



and  $\tilde{K}\psi^{-1}$  is holomorphic for  $\text{Im}(\lambda) \leq 0$ . Then

$$F = \tilde{H}H^{-1} = \tilde{K}K^{-1} \quad (3.23)$$

One choice which works is

$$K = \begin{pmatrix} \beta^{-1} & \beta^{-1}f(\omega) \\ 0 & -1 \end{pmatrix} \quad (3.24)$$

and

$$\tilde{K} = (K^\dagger)^{-1} = \begin{pmatrix} \beta^{-1} & 0 \\ f^\dagger(\omega) & -1 \end{pmatrix}, \quad (3.25)$$

where  $\beta = (\lambda - \mu_1)/(\lambda - \bar{\mu}_1)$ . Note that  $|\beta| \leq 1$  if and only if  $\text{Im}(\lambda) \geq 0$  and  $|\beta| \geq 1$  if and only if  $\text{Im}(\lambda) \leq 0$ . It is easy to check that the matrices  $H$  and  $\tilde{H}$  corresponding to  $K$  and  $\tilde{K}$  are invertible and holomorphic on the appropriate halves of the Riemann sphere, for those values of  $x, r, t$  and  $\lambda$  where  $f$  is holomorphic. If  $f$  has a pole then we replace  $f$  by  $g = 1/f$  and  $K$  and  $\tilde{K}$  by

$$K' = \begin{pmatrix} \beta^{-1}g(\omega) & \beta^{-1} \\ 1 & 0 \end{pmatrix}, \quad (3.26)$$

for  $|\beta| \leq 0$ , and

$$\tilde{K}' = \begin{pmatrix} 0 & \beta^{-1} \\ 1 & g^\dagger(\omega) \end{pmatrix}, \quad (3.27)$$

for  $|\beta| \leq 0$ .

So we can cover  $\mathbb{CP}^1 \times \mathbb{CP}^1$  by four coordinate patches

$$U : |\beta| \leq 1, \quad |f(\omega)| \leq 1$$

$$\tilde{U} : |\beta| \geq 1, \quad |f(\omega)| \leq 1$$

$$U' : |\beta| \leq 1, \quad |f(\omega)| \geq 1$$

$$\tilde{U}' : |\beta| \geq 1, \quad |f(\omega)| \geq 1.$$

We also have four matrix-valued functions of  $\beta$  and  $\omega$ ,  $K, \tilde{K}, K'$  and  $\tilde{K}'$  from which we can construct the patching matrices of the bundle. So, for example, the patching matrix from  $U$  to  $\tilde{U}$  is  $\tilde{K}K^{-1}$  and from  $U'$  to  $\tilde{U}'$  is  $\tilde{K}'K'^{-1}$  and so on.

Now examine the bundle in a neighbourhood of the line  $\lambda = \mu_1$ , (or  $\beta = 0$ ). This neighbourhood is covered by the two charts  $U$  and  $U'$ , and the patching matrix from  $U$  to  $U'$  is

$$K'K^{-1} = \begin{pmatrix} f(\omega)^{-1} & 0 \\ \beta & f(\omega) \end{pmatrix}. \quad (3.28)$$

So if we restrict the bundle  $E'$  to a line  $\lambda = \lambda'$ , then

$$E'_{|\lambda=\lambda'} = \mathcal{O}(0) \oplus \mathcal{O}(0), \quad (3.29)$$

when  $\lambda' \neq \mu_1, \bar{\mu}_1$  and

$$E'_{|\lambda=\mu_1} = E'_{|\lambda=\bar{\mu}_1} = \mathcal{O}(n) \oplus \mathcal{O}(-n), \quad (3.30)$$

where  $n$  is the degree of the rational function  $f$ .

In other words, the bundle  $E'$  is trivial over the lines  $\lambda = \lambda'$  except for  $\lambda = \mu_1$ . The line  $\lambda = \mu_1$  is said to be a jumping line of type  $(n, -n)$ . Similarly the line  $\lambda = \bar{\mu}_1$  will also be a jumping line of type  $(n, -n)$ . Generally the  $m$ -soliton solutions of Section 3.4 will correspond to bundles with  $2m$  jumping lines occurring when  $\lambda$  is  $\mu_1, \bar{\mu}_1 \dots \mu_m, \bar{\mu}_m$ . The type of the jumping lines will of course be determined by the degree of the rational functions  $f_1 \dots f_m$ .

# Chapter 4

## Solutions of the Bogomol'nyi Equations on ADS Space-time

In the last chapter we saw that the Bogomol'nyi equations in  $AdS^{2+1}$  were integrable and constructed solutions using the Riemann problem with zeros method. In this chapter we shall examine these solutions in more detail. These solutions have been considered independently by Zhou [43, 44] and Ioannidou [45, 46, 47]. The situation is of course similar to the case of Minkowski space-time  $\mathbb{M}^{2+1}$ , so we shall review this first.

### 4.1 Solutions for Minkowski Space-time

The Minkowski case was first considered by Ward, the most important papers from our point of view being [35, 36, 37, 48]. There have been other important contributions, the most relevant here is [49].

Recall that the Bogomol'nyi equations  $D\Phi = *F$  are

$$D_t\Phi = -F_{xy}, \quad D_x\Phi = +F_{yt}, \quad D_y\Phi = +F_{tx},$$

and are compatibility conditions for an over-determined linear system which in an

appropriate gauge is

$$\begin{aligned} Ls &= ((\partial_y + A) - \zeta(\partial_x + \partial_t))s, \\ Ms &= ((\partial_x - \partial_t + B) + \zeta\partial_y)s. \end{aligned}$$

Ward [35] took fundamental solutions of the form

$$\psi_{ab} = \delta_{ab} + \sum_{k=1}^N (\zeta - \mu_k)^{-1} n_a^k m_b^k. \quad (4.1)$$

To satisfy the reality condition

$$\psi(x, y, t, \bar{\zeta})^* = \psi(x, r, t, \zeta)^{-1},$$

we take

$$n_a^k = \sum_{l=1}^2 (\Gamma^{-1})^{kl} \bar{m}_a^l, \quad (4.2)$$

where

$$\Gamma^{kl} = \sum_{a=1}^2 (\bar{\mu}_k - \mu_l)^{-1} \bar{m}_a^k m_a^l. \quad (4.3)$$

By a homogeneity property of the  $m^k$  one can assume they are of the form  $(1, f_k)$  for some functions  $f_k$ . For  $A, B$  to be  $\zeta$ -independent  $f_k$  must depend on  $x, y, t$  only as a holomorphic function of

$$\gamma_k = \frac{1}{2}\mu_k^{-1}(x+t) + y - \frac{1}{2}\mu_k(x-t).$$

Ward took the  $f_k$  to be rational functions of  $\gamma_k$ . His motivation was the  $J$ -matrix equation for Minkowski space-time, i.e. the integrable chiral equation. Recall that if  $J$  is an  $SU(2)$  matrix satisfying

$$-(J^{-1}J_t)_t + (J^{-1}J_x)_x + (J^{-1}J_y)_y + [J^{-1}J_x, J^{-1}J_t] = 0,$$

$A, B$  are given by  $A = J^{-1}J_y$ ,  $B = J^{-1}J_x - J^{-1}J_t$ , and that if  $\psi$  is a fundamental solution (normalised so that  $\det \psi(0) = 1$ ), then  $J = \psi(0)^{-1}$  is a solution of the integrable chiral equation.

The integrable chiral model is the chiral model,

$$-(J^{-1}J_t)_t + (J^{-1}J_x)_x + (J^{-1}J_y)_y = 0,$$

plus the torsion term  $[J^{-1}J_x, J^{-1}J_t]$ . Now the chiral model has a conserved ‘energy’ density [35]. If we put

$$\begin{aligned} P_t &= -\frac{1}{2}((J^{-1}J_t)^2 + (J^{-1}J_x)^2) + (J^{-1}J_y)^2, \\ P_x &= -\text{tr}((J^{-1}J_t)(J^{-1}J_x)), \\ P_y &= -\text{tr}((J^{-1}J_t)(J^{-1}J_y)), \end{aligned}$$

then we have

$$(P_t)_t - (P_x)_x - (P_y)_y = -\text{tr}((J^{-1}J_t)(-(J^{-1}J_t)_t + (J^{-1}J_x)_x + (J^{-1}J_y)_y)),$$

so for solutions of the chiral equation we have the conservation law

$$(P_t)_t - (P_x)_x - (P_y)_y = 0.$$

Since the J-matrix equation differs from the chiral equation only by the torsion term  $[J_x^{-1}, J_t^{-1}]$  and

$$-\text{tr}((J^{-1}J_t)[J_x^{-1}, J_t^{-1}]) = 0,$$

it follows that the same conservation law applies for solutions of the J-matrix equation. Ward chose the functions  $f_k$  to be rational since, in this case, the Energy

$$E = \int \int \mathcal{E} dx dy$$

is finite and is conserved.

The  $N = 1$  solution is of the form

$$\psi(\zeta) = \mathbf{1}_2 - \frac{1}{(\zeta - \mu)} \frac{(\bar{\mu} - \mu)}{(1 + |f|^2)} \begin{pmatrix} 1 & f \\ \bar{f} & |f|^2 \end{pmatrix},$$

where we have written  $\mu$  and  $f$  for  $f_1$  and  $\mu_1$  respectively. The corresponding  $J$ -matrix is

$$J = \frac{1}{|\mu|(1 + |f|^2)} \begin{pmatrix} \mu + \bar{\mu}|f|^2 & (\mu - \bar{\mu})f \\ (\mu - \bar{\mu})\bar{f} & \bar{\mu} + \mu|f|^2 \end{pmatrix}.$$

Here of course  $f$  is a function of

$$\gamma = \frac{1}{2}\mu^{-1}(x + t) + y - \frac{1}{2}\mu(x - t).$$

In particular, if  $\mu = i$  then  $\gamma = -ix + y$  and the solution is static.

The quantity  $\|\Phi\|^2 = -\text{tr} \Phi^2$  is gauge invariant and positive definite. For the  $N = 1$  solution

$$\|\Phi\|^2 = |\gamma_y|^2 P = P,$$

where

$$P = 8 \frac{(\text{Im} \mu)^2}{|\mu|^2} \frac{|f'|^2}{(1 + |f|^2)^2},$$

and the energy density is

$$\begin{aligned} \mathcal{E} &= \frac{1}{2} (|\gamma_x|^2 + |\gamma_y|^2 + |\gamma_t|^2) P \\ &= \frac{(1 + |\mu|^2)^2}{4|\mu|^2} P \\ &= 2 \frac{(1 + |\mu|^2)^2 (\text{Im} \mu)^2}{|\mu|^4} \frac{|f'|^2}{(1 + |f|^2)^2}. \end{aligned}$$

So both quantities are constant multiples of  $P$ .

Recall from Section 3.1 that the solution of the equation  $\gamma = c$  is a time-like line in  $\mathbb{M}^{2+1}$  in the direction  $(2 \text{Re} \mu, 1 - |\mu|^2, -(1 + |\mu|^2))$ . Thus if  $\mu = m e^{i\theta}$  it represents a point moving in the  $xy$ -plane with velocity

$$(v_x, v_y) = \left( -\frac{2m \cos \theta}{1 + m^2}, \frac{1 - m^2}{1 + m^2} \right)$$

whose position at  $t = 0$  is given by  $c = -ix + y$ . Since  $\psi_0$  depends on  $x$ ,  $y$  and  $t$  only through  $\gamma$ , it follows that the gauge potential and Higgs field and as well as  $J$  and its associated energy are constant on the lines  $\gamma = c$ , and thus the  $N = 1$  solution represents travelling wave solution with the above velocity. In particular, if  $\mu = \pm i$  then the solution is stationary, if  $\mu$  is pure imaginary then it moves parallel to the  $x$ -axis, and for  $\mu$  with unit modulus it moves parallel to the  $y$ -axis.

If  $f(\gamma) = a(\gamma - b)$  and  $\xi$  is the point corresponding to  $\gamma = b$  for each value of  $t$ , then  $P$  and hence  $\|\Phi\|^2$  and  $\mathcal{E}$  take their its maximum values at  $\xi$  and are localised around the point. Thus the  $N = 1$  solution represents a lump which travels in a straight line with constant velocity. We regard  $\xi$  as the position of the lump and the corresponding line its path. The argument of  $a$  affects the shape of the soliton but not the location of the maximum values of  $\|\Phi\|^2$  and  $\mathcal{E}$ . For  $\mu = \pm i$  the solitons are static and are rotated by a change in the argument, with a more complicated

change for  $\mu \neq \pm i$ . The modulus  $|a|$  is a scale parameter. The maximum values of  $\|\Phi\|^2$  and  $\mathcal{E}$  are proportional to  $|a|^2$ . For large  $|a|$  the lump is more localised around  $\gamma = b$  than for small  $|a|$ , that is to say  $\|\Phi\|^2$  and  $\mathcal{E}$  decrease more rapidly away from  $\xi_k$  for large  $|a|$  than for small  $|a|$ . In fact the energy  $E$  is independent of the scale parameter.

One obtains the same result if one takes  $f = (a(\gamma - b))^{-1}$ . If  $f$  has both a pole and a zero it also represents a lump travelling on a time-like line. If  $f$  is of the form  $f(\gamma) = a(\gamma - b_1)(\gamma - b_2)$ , then, assuming  $b_1, b_2$  are sufficiently widely separated, it represents a two lumps located around  $\gamma = b_1, \gamma = b_2$ .

Crudely speaking  $\mu$  determines the velocity and  $f$  determines the shape. If  $f = (a(\gamma - b))^n$  for  $n \geq 2$ , then  $P$  is zero on  $\xi$  and takes its maximum on the solution  $C$  of  $|\gamma - b| = a^{-1}(2n - 1)^{1/n}$ , which for each fixed  $t$  is topologically a circle around  $\xi$ . Thus we have a ring soliton with zeros of the Higgs field  $\Phi$  and of the energy density  $\mathcal{E}$  at  $\xi$  and maxima of  $\|\Phi\|^2$  and  $\mathcal{E}$  on  $C$ . Similar results hold for poles of order  $n$ .

For  $N > 1$  the solutions represent a configuration of  $N$  lumps which travel along the paths  $\xi_k$  of the 1 lump solution corresponding to  $\mu_k$  and  $f_k(\gamma_k)$  which travel without scattering or changing shape. We shall thus refer to the solutions as solitons.

One can consider  $\psi$  with poles of higher multiplicity [35], e.g. a double pole

$$\psi(\zeta) = \mathbf{1}_2 + \frac{R_1}{\zeta - \mu} + \frac{R_2}{(\zeta - \mu)^2},$$

where  $R_1, R_2$  are independent of  $\zeta$ . The unitarity condition is satisfied if and only if  $\psi$  factorises as

$$\psi(\zeta) = \left( \mathbf{1}_2 + \frac{(\bar{\mu} - \mu) q^* \otimes q}{(\zeta - \mu) \|q\|^2} \right) \left( \mathbf{1}_2 + \frac{(\bar{\mu} - \mu) p^* \otimes p}{(\zeta - \mu) \|p\|^2} \right)$$

for 2-vectors  $p$  and  $q$  which are functions of  $\gamma$  only. A similar result holds for poles of multiplicity  $n$  —  $\psi$  satisfies the unitarity condition if and only if it can be written as the product of  $n$  such factors. To ensure  $A, B$  are independent of  $\zeta$  one takes a suitable limit of  $N = 2$  solutions with simple poles  $\mu_1, \mu_2$  such that  $\mu_k \rightarrow \mu$ .

Let us take  $\mu_1 = \mu + \epsilon$ ,  $\mu_2 = \mu - \epsilon$  then  $\psi$  is smooth in the limit  $\epsilon \rightarrow 0$  only if  $f_1 - f_2 \rightarrow 0$ . Writing  $f_1 = f + \epsilon h$ ,  $f_2 = f - \epsilon h$  and taking the limit as  $\epsilon \rightarrow 0$  gives a smooth solution  $\psi$  satisfying the unitarity condition and such that  $A, B$  are  $\zeta$ -independent with [48, 49]

$$p = (1, f), \quad (4.4)$$

$$q = (1 + |f|^2)(1, f) + (\bar{\mu} - \mu)g(\bar{f}, -1), \quad (4.5)$$

where

$$\begin{aligned} g &= \frac{\partial f_1}{\partial \epsilon} \\ &= \phi f' + h \end{aligned}$$

and

$$\begin{aligned} \phi &= \left. \frac{\partial \gamma_1}{\partial \epsilon} \right|_{\epsilon=0} \\ &= \frac{1}{2}(x - t) + \frac{1}{2}\mu^{-2}(x + t). \end{aligned}$$

In particular, if  $\mu = i$  then  $\phi = t$ . A number of examples have been described by Ward [48] and Ioannidou [49]:

**Example 4.1** If one takes  $\mu = i$ ,  $f(\gamma) = \gamma$  and  $h = 0$ , then the energy density  $\mathcal{E}$  and  $\|\Phi\|^2$  are rotationally-invariant for all  $t$ . For  $|t|$  sufficiently large  $\mathcal{E}$  takes its maximum value on a ring around the origin which for large  $|t|$  is of radius proportional to  $\sqrt{t}$  and takes a maximum value proportional to  $1/t$  (for small  $|t|$  it is a lump located at the origin). The quantity  $\|\Phi\|^2$  is also localised around a ring for  $|t|$  large (and again a lump for small  $|t|$  except for  $t = 0$  when  $\Phi \equiv 0$ ). Note that at the origin, which for each value of  $t$  is the solution of  $\gamma = 0$ ,  $\|\Phi\|^2$  is non-zero except when  $t = 0$ .

**Example 4.2** If one takes  $\mu = i$ ,  $f(\gamma) = \gamma^2$  and  $h = 0$ , then again  $\|\Phi\|^2$  and  $\mathcal{E}$  are rotationally symmetric for all  $t$ . For small  $|t|$  the energy density takes its maximum value on a ring around the origin, with the value at the origin non-zero except for  $t = 0$ . For large  $|t|$  the energy has a peak at the origin of height proportional to  $t^2$  and a ring of radius proportional to  $t^{1/3}$  and height proportional to  $t^{-2/3}$ . The situation is the same for  $\|\Phi\|^2$  except that  $\Phi \equiv 0$  at  $t = 0$ .



**Example 4.3** Perhaps the most interesting example is the scattering solution of Ward [48]. He took  $\mu = i$ ,  $f(\gamma) = \gamma$  and  $h(\gamma) = \gamma^2$ . If  $r = (x^2 + y^2)^{1/2}$  is the radial distance, then for large  $r$   $J$  will tend to its asymptotic value except when  $g = t + (-y + ix)^2$  is near to zero. Thus the solution represents two solitons at approximately  $x = 0$ ,  $y = \pm\sqrt{-t}$  for  $t < 0$  and  $x = \pm\sqrt{t}$ ,  $y = 0$  for  $t > 0$ . In other words two solitons collide head on and undergo a  $90^\circ$  scattering. More generally one can construct  $N$ -soliton solutions which scatter through an angle of  $180^\circ/N$  by taking  $\mu = i$ ,  $f(\gamma) = \gamma$  and  $h(\gamma) = \gamma^N$ .

Since one can take any rational functions  $f, h$  of  $\gamma$ , there are many other examples one can construct. For example, if  $\mu = i$ ,  $f(\gamma) = \gamma^2$  and  $h(\gamma) = \gamma^3$ , then  $g = t(-y + ix) + (-y + ix)^3$ , and, as one might expect, the solution consists of a soliton at the origin, plus two other solitons which undergo a  $90^\circ$  scattering at the origin.

One can of course consider also higher order poles (see for example [49]). For example, one can take  $\mu_1 = \mu + \epsilon$ ,  $\mu_2 = \mu$ ,  $\mu_3 = \mu - \epsilon$

$$\text{and } f_1 = f + \epsilon h + \epsilon^2 k, \quad f_2 = f, \quad f_3 = f - \epsilon h + \epsilon^2 k.$$

It is clear that for a triple pole there are even more possibilities than with a double pole.

## 4.2 1-Solitons

Now we shall look at solutions of the Bogomol'nyi equations in  $AdS^{2+1}$ . We shall start by considering the solutions obtained by the Riemann method with zeros in Section 3.4. In particular, in this section we shall consider the  $N = 1$  sector. We shall write  $\mu_1$  for  $\mu$ ,  $\omega_1$  for  $\omega$  and  $f_1$  for  $f$ .

The  $N = 1$  fundamental matrix solution is of the form

$$\psi(\lambda) = \mathbf{1}_2 - \frac{1}{(\lambda - \mu)} \frac{(\bar{\mu} - \mu)}{(1 + |f|^2)} \begin{pmatrix} 1 & f \\ \bar{f} & |f|^2 \end{pmatrix}.$$

By analogy with the Minkowski space-time solutions we shall take  $f$  to be a rational

function of

$$\omega = x - t - \frac{r^2}{\mu - (x + t)}.$$

In particular,

$$\psi(0) = \frac{1}{|\mu|(1 + |f|^2)} \begin{pmatrix} \bar{\mu} + \mu|f|^2 & (\bar{\mu} - \mu)f \\ (\bar{\mu} - \mu)\bar{f} & \mu + \bar{\mu}|f|^2 \end{pmatrix}$$

We shall define the norm-squared of the Higgs field by  $\|\Phi\|^2 = -4\text{tr}\Phi^2$ . Here it is given by

$$\|\Phi\|^2 = |l_0(\omega)|^2 P \tag{4.6}$$

$$= \frac{4r^4|\mu|^2}{|\mu - (x + t)|^4} P, \tag{4.7}$$

where

$$l_0 = r\partial_r + (x + t)(\partial_x + \partial_t),$$

and as before

$$P = 8 \frac{(\text{Im } \mu)^2}{|\mu|^2} \frac{|f'|^2}{(1 + |f|^2)^2}. \tag{4.8}$$

Recall from Section 3.2 that if one chooses a value  $\mu$  then the solution of the equation  $\omega = c$  is a time-like geodesic, when  $\text{Im } c$  and  $\text{Im } \mu$  have the same sign. The quantity  $P$  is a function of  $\omega$  only, so it is constant on the 2-parameter family of geodesics of the form  $\omega = c$  corresponding to  $\mu$ . This is analogous to the quantity  $P$  in the Minkowski space-time case which is constant on the 2-parameter family of time-like lines in the direction determined by  $\mu$ . However  $\|\Phi\|^2$  is not, as in the flat case, a constant multiple of  $P$ , since  $|l_0(\omega)|^2$  is a function of the space-time variables  $x$ ,  $r$ , and  $t$ . It is though constant on the geodesics  $\omega = c$ . It is easily verified that on such geodesics

$$|l_0(\omega)|^2 = \frac{4|\mu|^2(\text{Im } c)^2}{(\text{Im } \mu)^2}.$$

Thus the maximum of  $\|\Phi\|^2$  occurs on one of these geodesics, but it is not the one one might have expected from the Minkowski space-time case. In particular, if one takes  $f(\omega) = a(\omega - b)$ , where  $\text{Im } b$  has the same sign as  $\text{Im } \mu$ , then the maximum occurs not on  $\omega = b$  but on the geodesic  $\omega = c$ , where  $\text{Re } c = \text{Re } b$  and

$$(\text{Im } c)^2 = (\text{Im } b)^2 + |a|^{-2}.$$

Generally if one is given a solution in anti-deSitter space-time one can compare its behaviour with the analogous Minkowski space-time solution. For 1-solitons the behaviour in the curved space-time case is only approximately that of the flat case. The best one can say is that the maximum of  $\|\Phi\|^2$  is obtained near to  $\omega = b$  with this approximation best for large  $|a|$ , essentially because  $P$  depends on the scale parameter  $|a|$  and  $|l_0(\omega)|^2$  does not. We shall see that this is typical of the anti-deSitter space-time solutions. Their behaviour resembles that of the Minkowski space-time solutions and this approximation is best when the solution represents solitons which are highly localised, in particular when we discuss behaviour described in terms of geodesics. Intuitively we might have expected this result to hold — the effect of the curvature will be less over a small area and so if the solitons are more localised the behaviour of the solution will resemble closely the behaviour of the flat case. We shall give a more rigorous description of this idea when we discuss zero-curvature limits. For now it is enough to note that it is useful to consider the behaviour of our solutions in terms of their Minkowski equivalents, even if they do not do exactly what we expect. This will be useful when we consider the scattering solutions in Section 4.4, for example. It is also worth pointing out that some properties carry through exactly. We shall see this when we consider for example the  $N = 1$  solitons with higher degree  $f$  —  $\Phi$  has a zero lying on the same geodesic as for the flat case.

**Example 4.4** Let us take  $\mu = i$ ,  $f(\omega) = \omega - i$ . Plots of  $\|\Phi\|^2$  are shown for various values of  $t$  in Figure 4.1. The solution of  $\omega = i$  is the geodesic  $x = 0$ ,  $r^2 = 1 + t^2$ , but the maximum value of  $\|\Phi\|^2$  is attained on  $\omega = \sqrt{2}i$ , which is the geodesic  $x = (2\sqrt{2} - 3)t$ ,  $r^2 = \sqrt{2} + (12\sqrt{2} - 16)t^2$ . If one replaces  $f$  with  $f(\omega) = a(\omega - i)$ , then the path approaches  $\omega = i$  as  $|a| \rightarrow \infty$ . Paths for various values of  $a$  are shown in Figure 4.2. The argument of  $a$  affects the shape of the soliton, but the position depends on  $a$  only through its modulus, as in the Minkowski space-time case. The maximum value of  $\|\Phi\|^2$  is proportional to  $|a|^2$  and is more localised for large  $|a|$ . This is again similar to the Minkowski space-time case. We will make considerable use of the  $(X, Y, s)$  coordinate system introduced in Section 3.2. Figure 4.3 shows plots for several values of  $s$ . The geodesic  $\omega = i$  is in fact the origin in

these coordinates, and so the soliton is located approximately there. One can see that the size of the soliton in these coordinates changes with  $s$ . It is worth pointing out that if one takes  $\mu$  pure imaginary then the geodesic through the origin is the  $X$ -axis and if  $\mu$  has unit modulus then it is the  $Y$ -axis.

One might ask if there is an energy density for the  $J$ -matrix, just as there is for the chiral equation in the Minkowski space-time case. If we take

$$\begin{aligned} P_t &= -\frac{1}{2}r \operatorname{tr} ((J^{-1}J_t)^2 + (J^{-1}J_x)^2 + (J^{-1}J_r)^2), \\ P_x &= -r \operatorname{tr} ((J^{-1}J_t)(J^{-1}J_x)), \\ P_r &= -r \operatorname{tr} ((J^{-1}J_t)(J^{-1}J_r)), \end{aligned}$$

then we have

$$(P_t)_t - (P_x)_x - (P_r)_r = -r \operatorname{tr} ((J^{-1}J_t)(-(J^{-1}J_t)_t + (J^{-1}J_x)_x + \frac{1}{r}(rJ^{-1}J_r)_r))$$

But by the properties of trace this last expression is clearly the same as

$$-r \operatorname{tr} ((J^{-1}J_t)(-(J^{-1}J_t)_t + (J^{-1}J_x)_x + \frac{1}{r}(rJ^{-1}J_r)_r) + [J^{-1}J_x, J^{-1}J_t])$$

and this is of course zero for solutions of the  $J$ -matrix equation. However for the 1-solitons constructed above the integral of the energy density  $\mathcal{E} = P_t$  is not finite. In fact  $\mathcal{E}$  does not even tend to zero at infinity for our 1-solitons — see Figure 4.4 for the case of Example 4.4.

So far we have only considered examples where  $f$  is a rational function of degree 1. We can again consider  $f$  of degree  $n \geq 2$ . Let us take  $f = (a(\omega - b))^n$  and we shall assume that  $\operatorname{Im} b$  and  $\operatorname{Im} \mu$  are of the same sign so that  $\omega = b$  is a geodesic. Then, as in the flat case,  $P$  has a zero on  $\omega = b$  and takes its maximum value on the solution  $C$  of  $|\omega - b| = |a|^{-1}(2n - 1)^{1/n}$  which again is topologically a circle around  $\omega = b$  for each value of  $t$  (or  $s$ ). From (4.7) it is clear that  $\Phi$  has a zero on  $\omega = b$ , exactly as in the Minkowski space-time case. The solution represents crudely a ring soliton located around  $C$ . However this behaviour is not an exact analogue of the flat case, the maximum of  $\|\Phi\|^2$  is not located on  $C$  for example, since  $\|\Phi\|^2$  is not a constant multiple of  $P$ . The best one can say is, as for  $f$  of degree greater than 1,

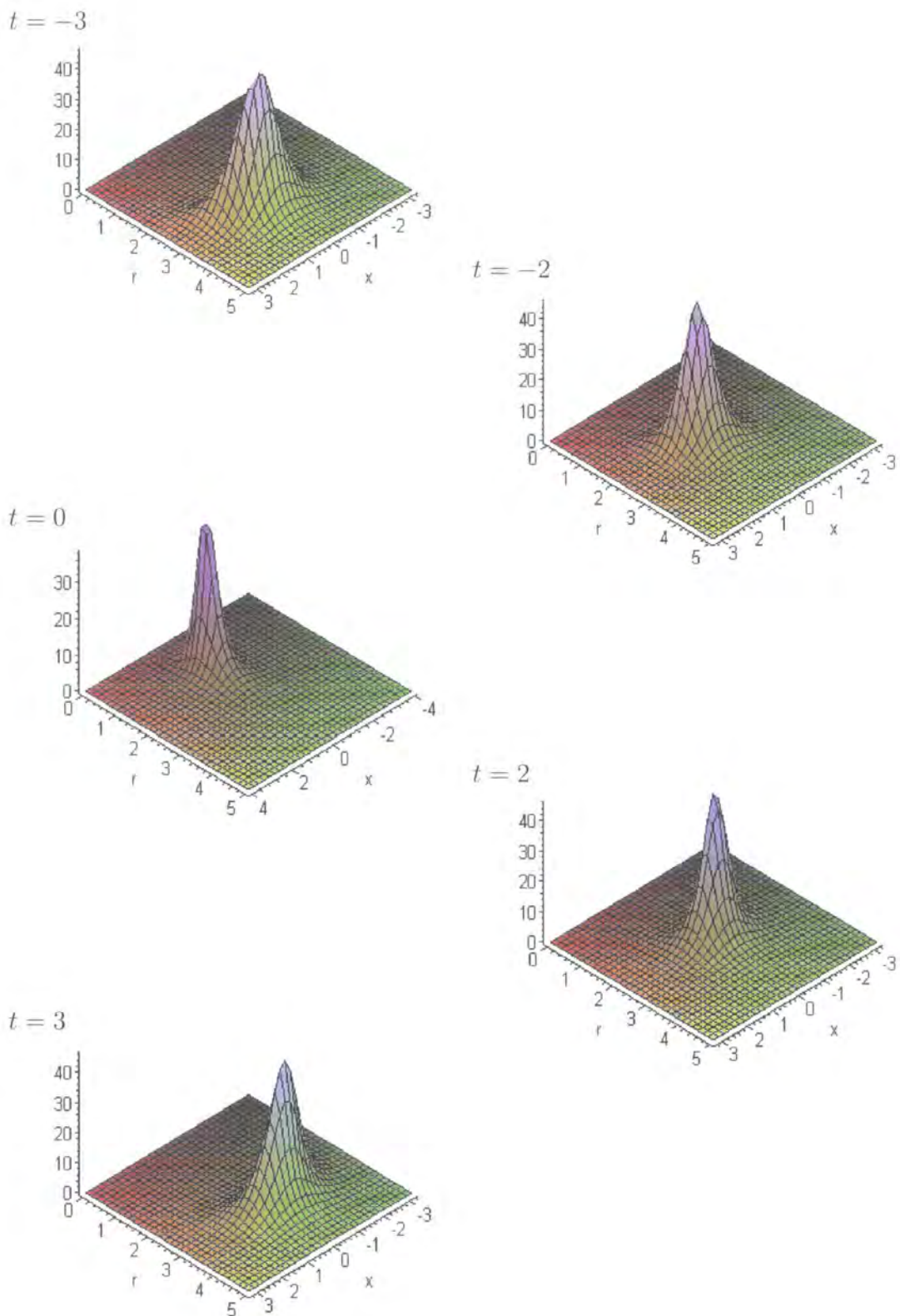

Figure 4.1: Example 4.4 —  $\|\Phi\|^2$  for various values of  $t$ .

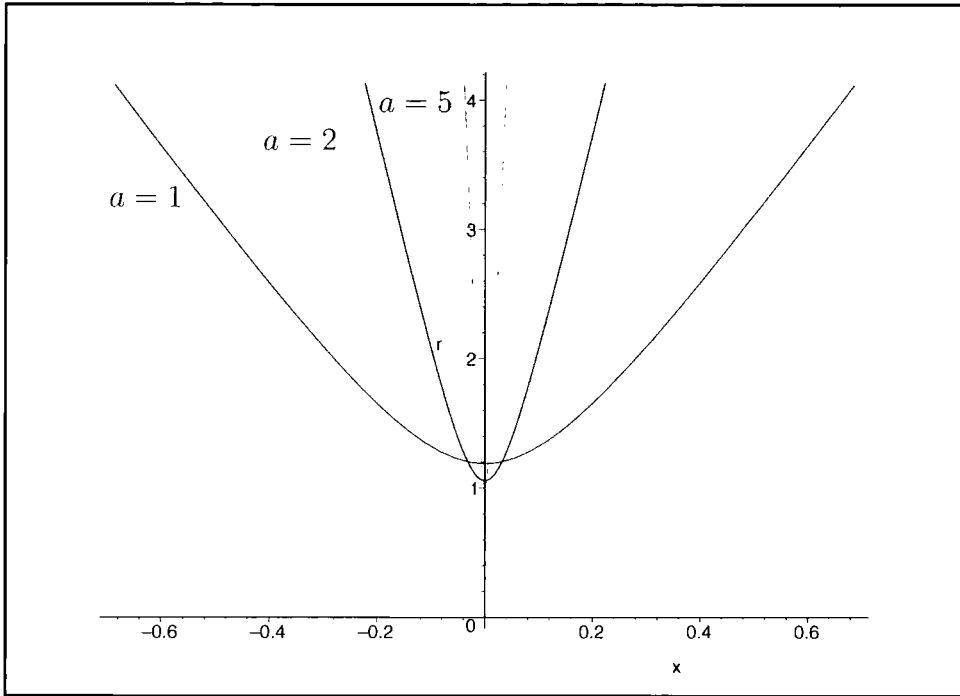

Figure 4.2: Soliton paths for various values of the scale parameter  $a$ .

that, since  $P$  depends on  $a$  and  $|l_0(\omega)|$  does not, the behaviour in the anti-deSitter case best resembles that of the Minkowski case when  $|a|$  is large.

**Example 4.5** Take  $\mu = i$ ,  $f = (a(\omega - i))^2$ .  $\Phi$  has a zero on  $x = 0$ ,  $r^2 = 1 + t^2$  or equivalently at  $X = 0$ ,  $Y = 0$  in the  $(X, Y, s)$  coordinate system. Figure 4.5 shows  $\|\Phi\|^2$  for various values of  $a$  at  $s = 0$ .

### 4.3 Trivial Scattering

Now we shall consider the solutions for  $N \geq 2$ . In fact we shall focus on the  $N = 2$  case, although many conclusion will extend to  $N > 2$ .

Let us take the  $N = 2$  solution of Section 3.4 with poles  $\mu_1$  and  $\mu_2$  and with  $f_k = a_k(\omega_k - b_k)$  for constants  $a_k, b_k$ . If one takes the limit of the fundamental matrix solution  $\psi$  as  $|f_2| \rightarrow \infty$  with  $f_1$  held constant, then one obtains an  $N = 1$  fundamental matrix solution  $\psi_1$ . This solution is not the solution corresponding to  $\mu_1$  and  $f_1$  — there is a change of scale parameter by a factor of  $|(\mu_2 - \mu_1)/(\bar{\mu}_2 - \mu_1)|$ .

$s = -1$

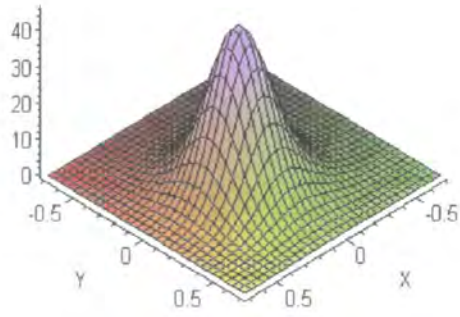

$s = -0.7$

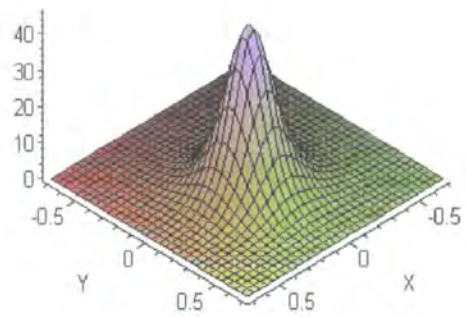

$s = 0$

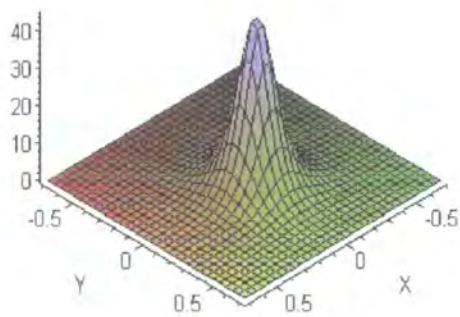

$s = 0.7$

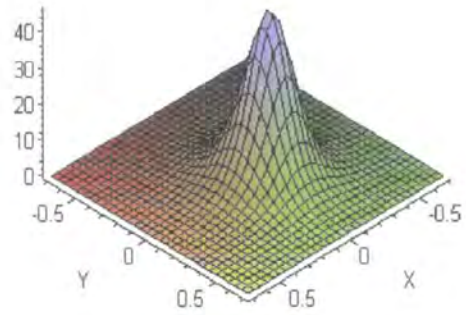

$s = 1$

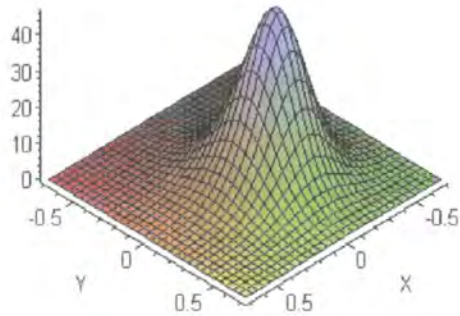

Figure 4.3: Example 4.4 —  $\|\Phi\|^2$  for various values of  $s$ .

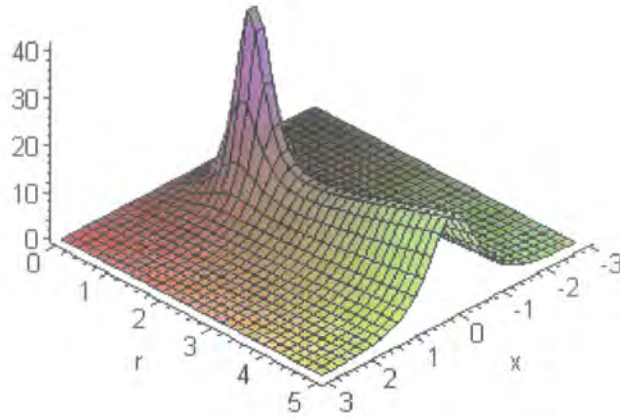

Figure 4.4: Example 4.4 — Energy density  $\mathcal{E}$  at  $t = 0$ .

In fact the relevant solution is  $\mu = \mu_1$  and  $f = ((\mu_2 - \mu_1)/(\bar{\mu}_2 - \mu_1))f_1$ . There is a similar result of course if we hold  $\omega_2$  fixed and take the limit of  $\psi$  as  $|f_1| \rightarrow \infty$ . Call the corresponding  $N = 1$  solution  $\psi_2$ . Now on the geodesic  $\omega_1 = c$ , if we let  $|t| \rightarrow \infty$  (or  $|s| \rightarrow \infty$ ), then  $|\omega_2|$  becomes infinite and hence so does  $|f_2|$ . So, for large  $|t|$  (or large  $|s|$ ),  $\psi$  is given approximately by  $\psi_1$  on the geodesic. Since a similar result holds for geodesics of the form  $\omega_2 = c$ , it follows that the  $N = 2$  solutions behave like two solitons which interact without scattering. This behaviour is the same as for the Minkowski space-time case except that the paths of the solitons are not given exactly by  $\omega_k = b_k$ , but are close for large  $|a_k|$  just as in the flat case.

**Example 4.6** Figure 4.6 shows the solution for  $\mu_1 = i$ ,  $\mu_2 = 2i$ ,  $f_1 = 5(\omega_1 - i)$ ,  $f_2 = 10(\omega_2 - i/2)$ . Because of the choice of scale parameters the solitons are located approximately on  $\omega_1 = i$  and  $\omega_2 = i/2$  for large values of  $s$ . These paths are respectively the origin and the  $X$ -axis. (The exact paths are  $\omega_1 = \sqrt{26/25}i$  and  $\omega_2 = \sqrt{13/25}i$ ).



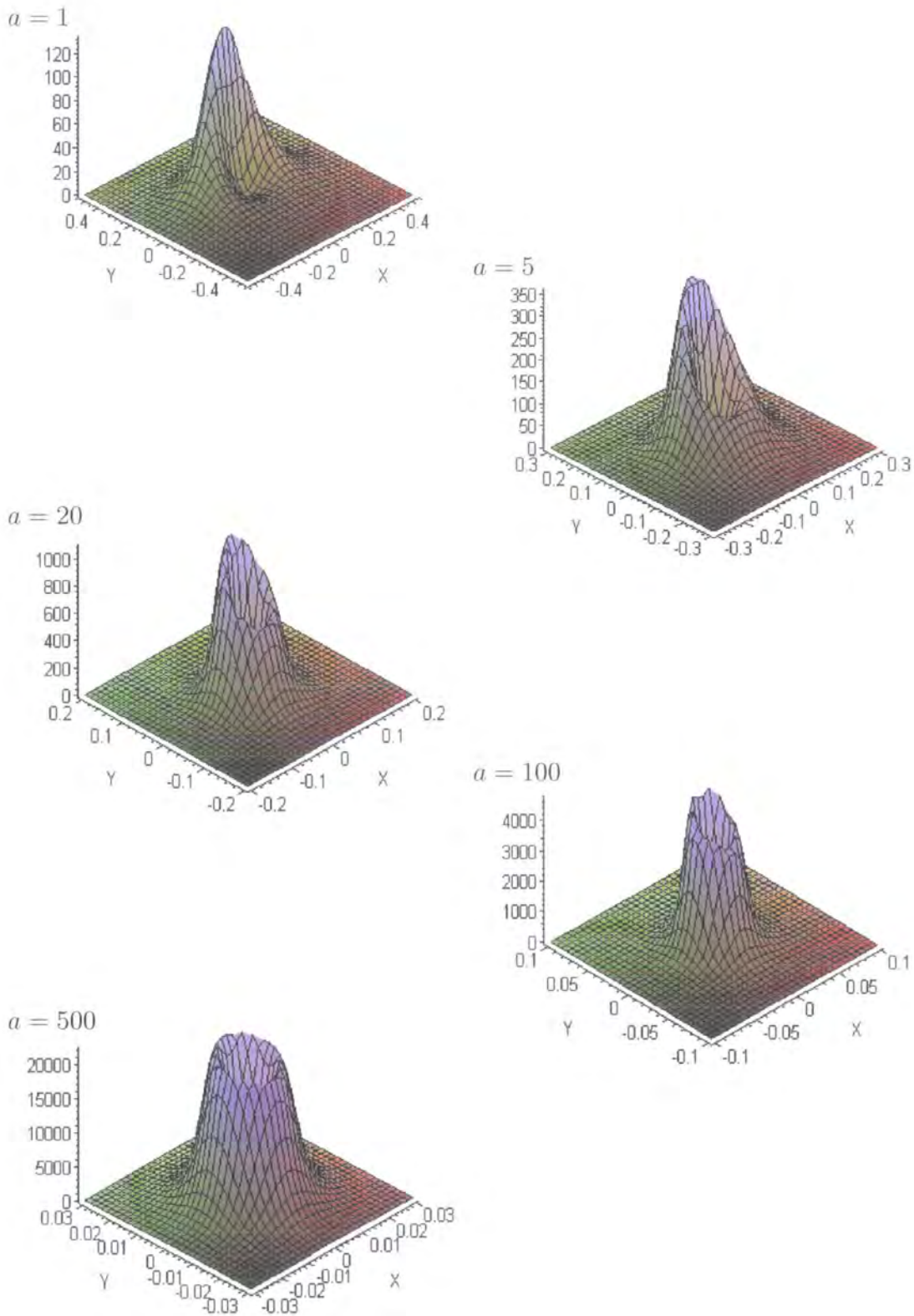
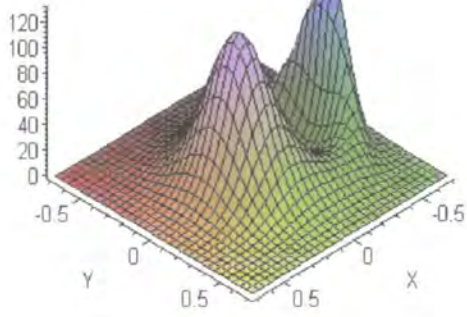
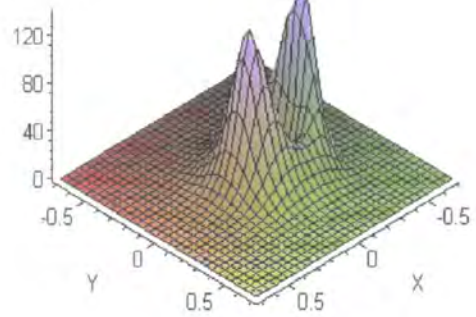

Figure 4.5: Example 4.5 —  $\|\Phi\|^2$  at  $s=0$  for various values of  $a$ .

$s = -1.18$



$s = -0.81$



$s = 0$

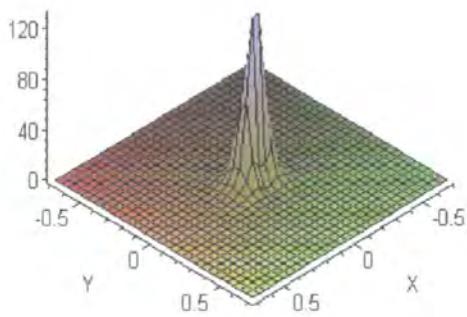

$s = 0.81$

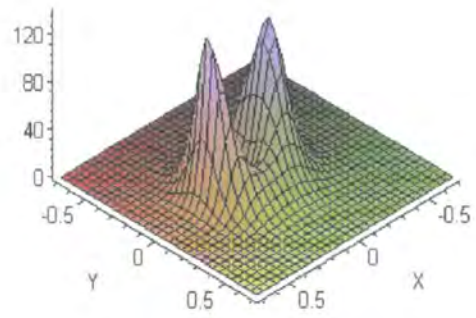

$s = 1.18$

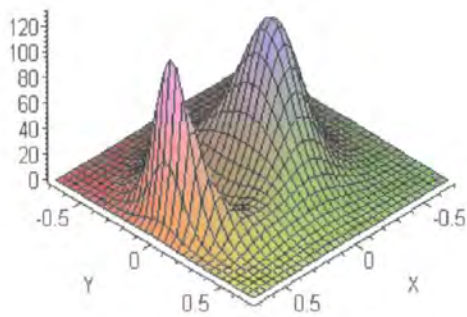

Figure 4.6: Example 4.6 —  $\|\Phi\|^2$  for various values of  $s$ .

## 4.4 Limiting Cases and Non-trivial Scattering

As in the Minkowski space-time case one can consider fundamental matrix solutions with a double pole, i.e. of the form

$$\psi(\lambda) = \mathbf{1}_2 + \frac{R_1}{\lambda - \mu} + \frac{R_2}{(\lambda - \mu)^2},$$

where  $R_1, R_2$  are functions of  $\omega$ . The extension of the Minkowski-case solutions to anti-deSitter space-time is straightforward. Again the unitarity condition is satisfied if and only if

$$\psi(\lambda) = \left( \mathbf{1}_2 + \frac{(\bar{\mu} - \mu) q^* \otimes q}{(\lambda - \mu) \|q\|^2} \right) \left( \mathbf{1}_2 + \frac{(\bar{\mu} - \mu) p^* \otimes p}{(\lambda - \mu) \|p\|^2} \right)$$

for 2-vectors  $p$  and  $q$ , which are functions of  $\omega$  only. As for the flat case we ensure the gauge potential and Higgs field are independent of  $\lambda$  by taking appropriate limits of the  $N = 2$  solutions discussed previously.

An obvious thing to try and do is to consider the anti-deSitter analogues of the Minkowski space-time solution of Section 4.1. As a first attempt we consider  $N = 2$  solution with poles at  $\mu_1 = \mu + \epsilon$ ,  $\mu_2 = \mu - \epsilon$  and take  $f_1(\omega_1) = f(\omega_1) + \epsilon h(\omega_1)$ ,  $f_2(\omega_2) = f(\omega_2) - \epsilon h(\omega_2)$ . Then in the limit  $\mu \rightarrow 0$ , exactly as in the flat case [48, 49],

$$p = (1, f), \tag{4.9}$$

$$q = (1 + |f|^2)(1, f) + (\bar{\mu} - \mu)g(\bar{f}, -1), \tag{4.10}$$

where

$$g = \left. \frac{\partial f_1}{\partial \epsilon} \right|_{\epsilon=0} \tag{4.11}$$

$$= \phi f' + h \tag{4.12}$$

$$\text{and} \tag{4.13}$$

$$\phi = \frac{\partial \omega}{\partial \epsilon} \tag{4.14}$$

$$= \frac{r^2}{(\mu - (x + t))^2}. \tag{4.15}$$

Ioannidou has obtained this result in [45].

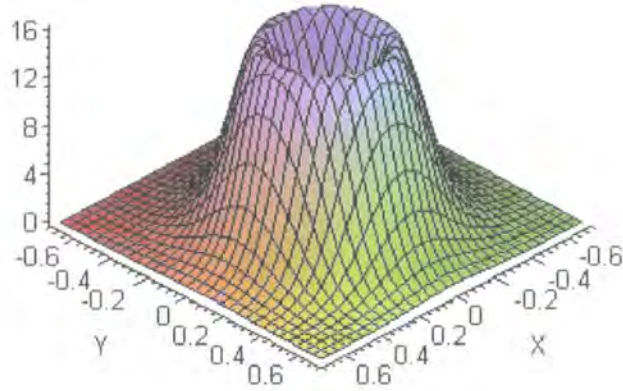

Figure 4.7: Example 4.7 —  $\|\Phi\|^2$  at  $s = 0$ .

**Example 4.7** Take  $\mu = i$ ,  $f(\omega) = \omega - i$ . Then  $\|\Phi\|^2$  actually depends on  $x$ ,  $r$  and  $t$  only as a function of  $\omega$  and is given by

$$\|\Phi\|^2 = 128 \frac{(\text{Im } \omega)^2 ((2 + |\omega|^2)^2 - 8(\text{Im } \omega)^2)}{((2 + |\omega|^2)^2 + 4 \text{Im } \omega (2(\text{Im } \omega - 1) - |\omega|^2))^2}.$$

This gives a ring soliton with a zero of  $\Phi$  on  $\omega = \sqrt{2}i$  and with  $\|\Phi\|^2$  taking its maximum on  $|\omega - 2i| = \sqrt{2}$ , see Figure 4.7. One should not think of this as the analogue of Example 4.1 as one might think at first from our choice of  $\mu$ ,  $f$  and  $h$  (we shall discuss what is later). For one thing  $\|\Phi\|^2$  is not just a function of  $\omega$  in the Minkowski case — if it were it would be time independent. In particular in this example  $\Phi$  has a zero for all  $t$  (or equivalently for all  $s$ ).

Ioannidou considered a similar example in [45]. She took  $f(\omega) = \omega$ ,  $h = 0$ . Again this is a function of  $\omega$  only. This has a zero at the solution of  $\omega = i$ , i.e.  $x = 0$ ,  $r^2 = 1 + t^2$ . In the  $X$ ,  $Y$ ,  $s$  coordinate system this solution is dependent only on  $S$  and the radial distance  $\rho = (X^2 + Y^2)^{1/2}$ .

**Example 4.8** Take  $\mu = i$ ,  $f(\omega) = (\omega - i)^2$ . This gives a soliton with a “spike” approximately located at  $\omega = i$  and surrounded by a ring-like structure (see Figures 4.8 and 4.9). It is thus similar to the Minkowski case Example 4.2, however it too should not be thought of as the analogous case to Example 4.2 as we shall see.

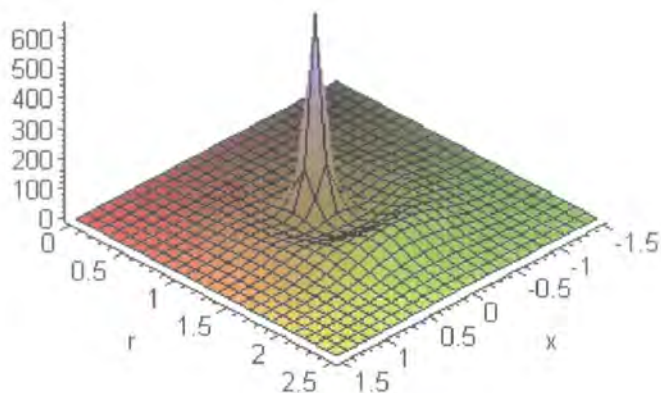

Figure 4.8: Example 4.8 —  $\|\Phi\|^2$  at  $t = 0$ .

Perhaps the most interesting thing to attempt is to find solutions that undergo scatterings as in the Minkowski case. It is difficult to make sense of the idea of a  $90^\circ$ -scattering, for example, in the  $(x, r, t)$  system. However in the  $(X, Y, s)$  coordinate system one can make sense of it. We shall aim to construct solutions consisting of 2 or more solitons which meet at the origin at  $s = 0$  and scatter at various angles. By analogy with the flat case one might expect taking  $\mu = i$ ,  $f(\omega) = \omega - i$  and  $h(\omega) = (\omega - i)^2$  might do the job. However the result is two solitons which hardly move in the  $(X, Y)$ -plane. (One might also have expected  $f(\omega) = \omega$ ,  $h(\omega) = \omega^2$  to work but this gives even worse results). Again as in Example 4.7 the behaviour of the Minkowski case does not seem to go over to the anti-deSitter case, even to the extent that the  $N$ -soliton solutions did.

The problem is in the choice of solutions whose limit is taken, or equivalently in our choice of  $\omega_k$ . For each singularity we could have chosen any combination of  $x$ ,  $r$  and  $t$  which is eliminated by the operators

$$l_k = \partial_r + \frac{\mu_k - (x + t)}{r}(\partial_x + \partial_t) \quad (4.16)$$

and

$$m_k = \partial_x - \partial_t + \frac{\mu_k - (x + t)}{r}\partial_r. \quad (4.17)$$

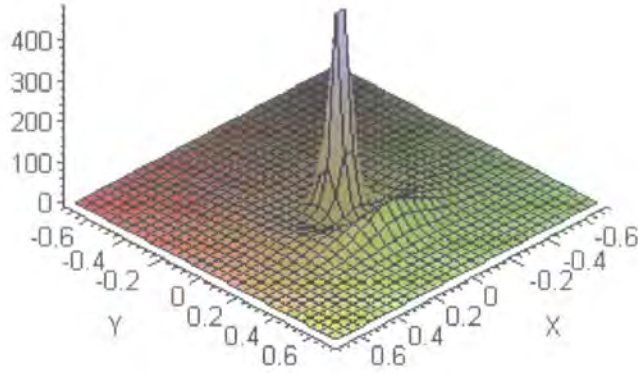

Figure 4.9: Example 4.8 —  $\|\Phi\|^2$  at  $s = 0$ .

The way we have chosen the  $\omega_k$  they may seem to bear little resemblance to the corresponding Minkowski space-time quantity used in Section 4.1,

$$\frac{1}{2}\mu_k^{-1}(x+t) + y - \frac{1}{2}\mu_k(x-t).$$

However if we multiply  $\omega_k$  by  $\mu_k$  then we obtain

$$\mu_k(x-t) - \frac{r^2}{1 - \mu_k^{-1}(x+t)},$$

which looks much more similar. In fact if we consider  $\gamma_k = \mu_k\omega_k + 1$  and put  $r = 1 + y$  then for small  $x, y, t$  (i.e. to first order)

$$\gamma_k \approx \mu_k(x-t) - 2y - \mu_k^{-1}(x+t), \quad (4.18)$$

which is the Minkowski space-time quantity (except for a factor of  $-2$ ). In particular when  $\mu = i$  one has  $2i(x + iy)$ . A better argument is to use the coordinates  $(X, Y, s)$  coordinate system. To lowest order in  $X, Y$ , and  $s$ ,  $x \approx 2X$ ,  $r \approx 1 - 2Y$ , and  $t \approx s$ . So if we express  $\gamma_k$  in terms of  $X, Y$  and  $s$  then, again to lowest order,

$$\gamma_k \approx \mu_k(2X - s) + 4Y - \mu_k^{-1}(2X + s),$$

which is again the Minkowski space-time quantity if we identify  $2X$  with  $x$ ,  $-2Y$  with  $y$  and  $s$  with  $t$  (the factors of 2 occur because of our choice of coordinates in

the  $(X, Y, s)$  coordinate system and in particular our decision to make  $(X, Y)$  lie within a unit disc rather than the more natural choice of a disc of radius  $1/2$ ). Both these approximations will resurface when we consider zero-curvature limits in the next section. All this suggests that we should use  $\gamma_k$  in place of  $\omega_k$  to obtain solution analogous to those in the Minkowski case.

So as before we shall take  $\mu_1 = \mu + \epsilon$ ,  $\mu_2 = \mu - \epsilon$  but this time we replace  $\omega_k$  with  $\gamma_k$ , i.e. we take  $f_1(\gamma_1) = f(\gamma_1) + \epsilon h(\gamma_1)$ ,  $f_2(\gamma_2) = f(\gamma_2) - \epsilon h(\gamma_2)$ . In the limit  $\mu \rightarrow \infty$  one obtains a similar factorisation of  $\psi(\lambda)$  with  $p$  and  $q$  and given by (4.9), (4.10), but this time  $g$  is given by

$$\left( (x-t) + \frac{r^2}{(1-\mu^{-1}(x+t))^2} \mu^{-2}(x+t) \right) f'(\gamma) + h(\gamma).$$

Note that again to first order  $\phi$  is given by

$$(x-t) - \mu^{-2}(x+t)$$

or, in terms of  $X, Y$  and  $s$ ,

$$(2X-s) - \mu^{-2}(2X+s).$$

which is the same as the equivalent Minkowski space-time quantity (again with the factor of -2), further suggesting that this is the right approach. Again in particular when  $\mu = i$  and  $\phi = -2t$ . (Note that we could have carried out our analysis of the 1-soliton and trivial scattering solutions using  $\gamma_k$  in place of  $\omega_k$  — the conclusions would be the same since the set of rational functions of  $\gamma_k$  is the same as the set of rational functions of  $\omega_k$  — and in fact this would be the more natural approach.)

With all this one might hope that one could use this method to construct scattering solutions analogous to the Minkowski solutions by choosing a limit of solitons which are highly localised by the choice of a large scale parameter. For small time intervals around  $t = 0$  and in a neighbourhood of  $x = 0$ ,  $r = 1$  (or equivalently for small time intervals around  $s = 0$  and in a neighbourhood of  $X = 0$ ,  $Y = 0$ ) the closeness of the the anti-deSitter space-time quantity  $\gamma$  to its Minkowski space-time equivalent would mean hopefully that the solitons meeting at  $x = 0$ ,  $r = 1$  at  $t = 0$  would scatter as in the Minkowski case, although the long-term behaviour might be

different. We shall see that this is indeed the case. First however we shall return to the question of what solutions (if any) most naturally correspond in the anti-deSitter case to Example 4.1 in the Minkowski case.

**Example 4.9** Take  $\mu = i$  and  $f(\gamma) = a\gamma$ ,  $h(\gamma) = 0$  where we shall assume  $a > 0$ . For  $s$  small it represents a lump located around  $X = 0$ ,  $Y = 0$ . For larger values of  $s$  the solution represents a more ring-like structure (see Figure 4.10). This mostly resembles the Minkowski space-time case for  $a$  large as one might expect.

We now shall construct the solutions analogous to the Minkowski space-time scattering solutions described in Section 4.1. Recall that if one chooses  $\mu = i$ ,  $f(\gamma) = \gamma$  and  $h(\gamma) = \gamma^N$  then one obtains a solution corresponding to a configuration of  $N$  solitons which undergo a  $180^\circ/N$ -scattering at the origin at  $t = 0$ . More generally if one considers  $f = a\gamma$ ,  $h = ba^N\gamma^N$ , then one obtains a configuration of solitons located at points  $(x, y)$  where  $-y + ix$  given by the  $N^{\text{th}}$  roots of  $-t/b$ .

So we shall take  $\mu = i$ ,  $f = a\gamma$ ,  $h = ba^N\gamma^N$ , ( $a, b$  real) for the anti-deSitter case also. Choosing  $a$  large and considering small intervals of  $s$ , gives solutions which undergo an approximate  $180^\circ/N$ -scattering at the origin, although they leave these paths for large  $s$ . One can crudely rotate this configuration by an angle of  $\phi$  by replacing  $b$  with  $be^{iN\theta}$ .

**Example 4.10** Take  $N = 2$ ,  $a = 4$ ,  $b = 4$ . Figure 4.11 shows this solution. Two solitons approach the origin roughly along the  $Y$ -axis for  $s < 0$ , begin to interact with each other, form a ring soliton at  $s = 0$  and then exit along the  $X$ -axis for  $s > 0$ . Note that the paths are not exactly the axes, the solitons are not the same height and the ring soliton is not exactly symmetric. It is however clearly similar to the corresponding Minkowski space-time case.

**Example 4.11** Take  $N = 3$ ,  $a = 4$ ,  $b = 4$ . Figure 4.12 shows this solution. Three solitons approach the origin roughly at angles of  $120^\circ$  to each other, one along the positive  $Y$ -axis for  $s < 0$ , begin to interact with each other, form a ring soliton at  $s = 0$  and then exit undergoing a  $60^\circ$ -scattering  $s > 0$ . As in the previous example the behaviour is analagous to the behaviour seen in the Minkowski case.



$a = 1$

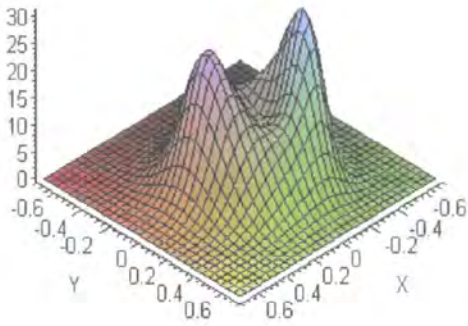

$a = 2$

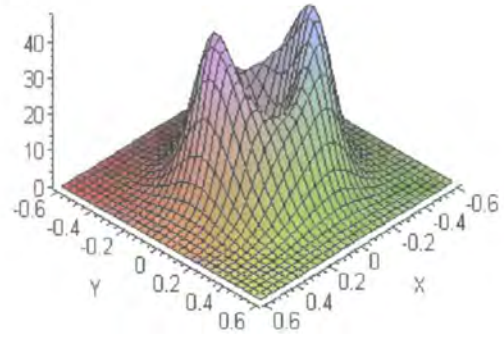

$a = 5$

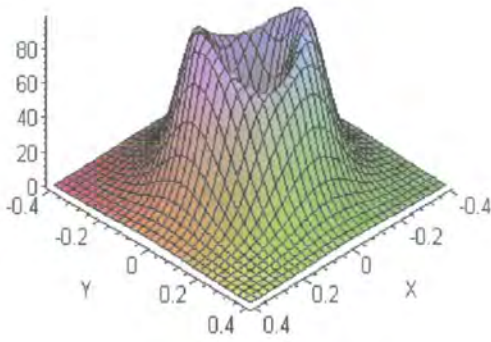

$a = 10$

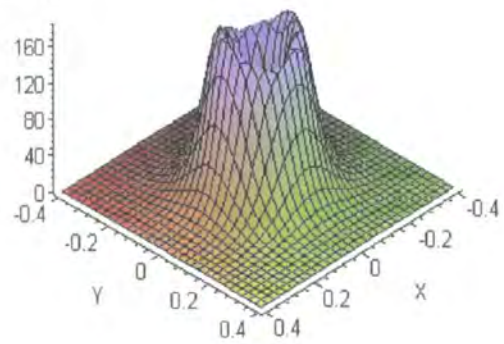
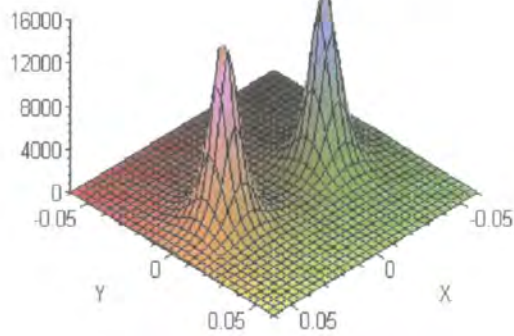
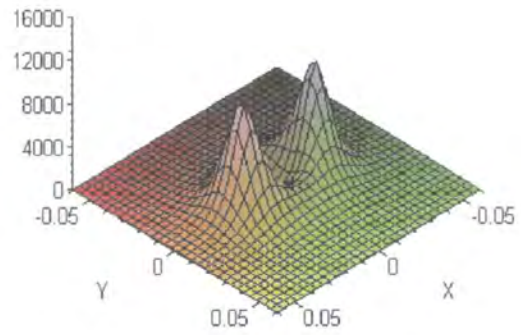

Figure 4.10: Example 4.9 —  $\|\Phi\|^2$  at  $s = 0.64$  for various values of  $a$ .

$s = -0.1$



$s = -0.04$



$s = 0$

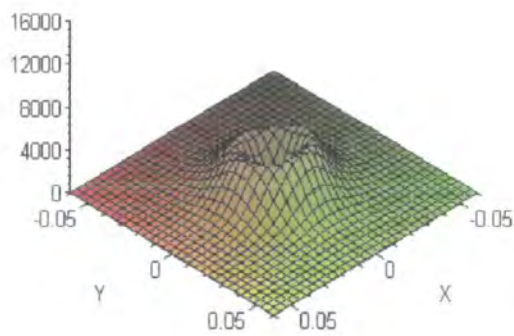

$s = 0.04$

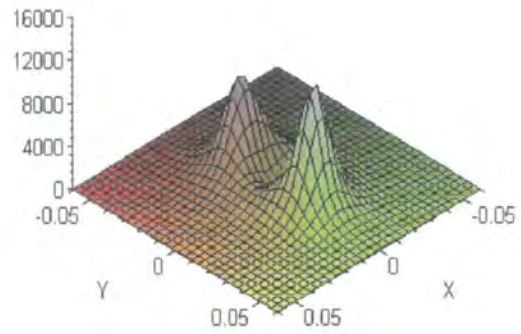

$s = 0.1$

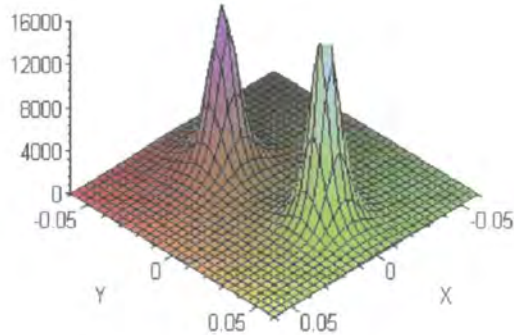
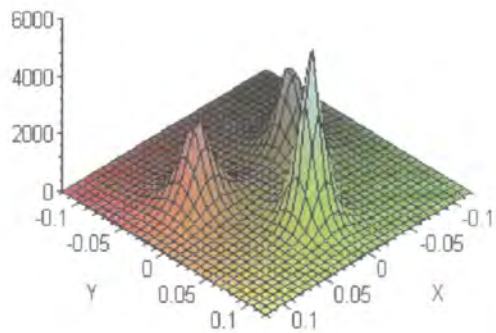
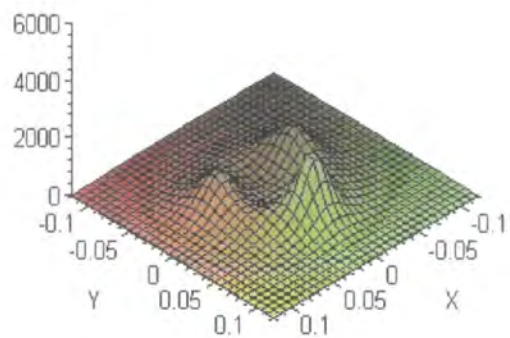

Figure 4.11:  $90^\circ$  scattering. Example 4.10 —  $\|\Phi\|^2$  for various values of  $s$ .

$s = -0.1$



$s = -0.025$



$s = 0$

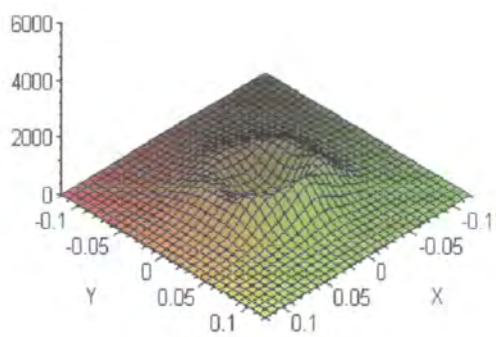

$s = 0.025$

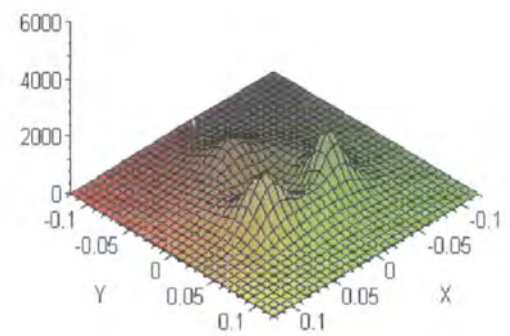

$s = 0.1$

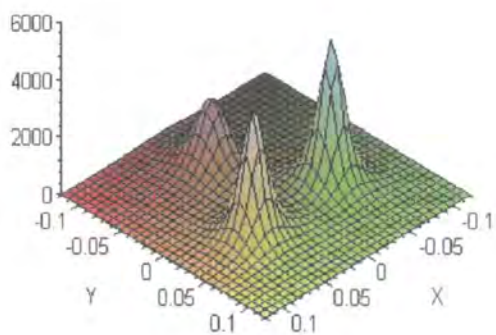

Figure 4.12:  $60^\circ$  scattering. Example 4.11 —  $\|\Phi\|^2$  for various values of  $s$ .

## 4.5 Zero-Curvature Limit

In [20] Atiyah described the process whereby one considers families of monopole solutions on hyperbolic spaces, one solution for each value of the scalar curvature of the space and recovers Euclidean monopoles by taking a suitable limit as the scalar curvature tends to zero. This is equivalent, by a rescaling argument, to taking a family of hyperbolic monopoles on a space with a given scalar curvature but with different boundary conditions (different asymptotic values for the Higgs field) in each case.

In this section we shall attempt to perform the analogous process for solutions of the Bogomol'nyi equations in the  $(2 + 1)$ -dimensional case. One reason for doing this is it helps explain the similarity between the behaviour of the solutions in anti-deSitter and Minkowski space-times.

There are a number of ways of carrying out this limiting process. We shall consider two basic approaches although there are a number of variations on each of these. One is to recover the Minkowski space-time solutions directly from the anti-deSitter solutions. This involves recovering Minkowski space-time itself as a zero-curvature limit of a family of anti-deSitter space-times. The second approach is to consider solutions of the ASDYM on a family of regions in ultrahyperbolic space-time which are each invariant under a 1-dimensional group of "Lorentz boosts", which converge to a solution on the whole of  $\mathbb{U}$  which is invariant under a 1-dimensional group of translations and so corresponds to a solution of the Minkowski space-time equations. This approach as we shall see can be viewed as a zero curvature limit and is basically the same as the first. This is analogous to a process described by Atiyah where one considers families of solutions of the ASDYM equations parameterised by a real number  $p$ , invariant under a 1-dimensional group of rotations in which the invariant plane is taken to infinity along one axis

We shall start with the latter approach. We shall work with the ultrahyperbolic slice  $\mathbb{U}_1$  with coordinates  $x$ ,  $y$ ,  $t$  and  $u$  as in Section 3.1. For each  $p > 0$  we shall consider the wedge  $y + p > |s|$ , as we did (with  $p = 0$ ) in Section 3.2. Take

coordinates

$$\begin{aligned} y &= r \cosh(\theta) - p \\ u &= r \sinh(\theta). \end{aligned}$$

We shall look for solutions of the ASDYM which are invariant under  $\partial_\theta = (y+p)\partial_y - u\partial_u$  (that is  $(w+p)\partial_w - (\tilde{w}-p)\partial_{\tilde{w}}$  in the double-null coordinate system). These will of course correspond to solutions of the Bogomol'nyi equations in anti-deSitter space-time. Note that  $p^{-1}\partial_\theta \longrightarrow \partial_u = (\partial_w + \partial_{\tilde{w}})$  and so the limit of such a family of solutions corresponds to a solution of the Minkowski space-time Bogomol'nyi equations. What we shall actually do is look for fundamental matrix solutions of the Lax pair for the ASDYM invariant under  $\theta$  which in a suitable limit converge to solutions invariant under  $u$  as in the Minkowski case, which will in turn give the appropriate ASDYM solutions. We shall start by looking at the  $N$ -soliton solutions and then discuss the limiting cases and scattering solutions.

The  $N$ -soliton solutions described in Section 3.4 are described in terms of an invariant spectral parameter. To construct the required family of solutions one needs an invariant spectral parameter which converges to  $\zeta$  as  $p \longrightarrow \infty$ . The generalisation of the usual invariant spectral parameter is

$$\begin{aligned} \lambda &= \zeta r e^\theta + x + t \\ &= \zeta(w+p) + \tilde{z}. \end{aligned}$$

If one defines  $\nu = \lambda/p$  then, as  $p \longrightarrow \infty$ ,  $\nu \longrightarrow \zeta$  so we shall work  $\nu$  as our invariant spectral parameter.

One can repeat the analysis of Section 3.4 with  $\nu$  in place of  $\lambda$ , and one finds that  $\psi(\nu)$  is given by (3.13) as before, but  $m_k^a$  are functions of

$$\omega_k = (x-t) - \frac{r^2}{p\mu_k - (x+t)}$$

Instead we shall take the  $m_k^a$  to depend on  $x, r, t$  as a rational function  $f_k$  of

$$\gamma_k = \mu_k(x-t) - \frac{r^2}{p - \mu_k^{-1}(x+t)} + p.$$

As functions of  $x$ ,  $y$ ,  $t$  and  $u$

$$\begin{aligned}
\gamma_k &= \mu_k(x+t) - \frac{(p+y)^2 - u^2}{p - \mu_k(x+t)} + p \\
&= \mu_k(x-t) - p((1+y/p)^2 - (u/p)^2)(1 - \mu^{-1}(x+t)/p)^{-1} + p \\
&= \mu_k(x-t) - p((1+y/p)^2 - (u/p)^2)(1 + \mu^{-1}(x+t)/p + \dots) + p \\
&\longrightarrow \mu_k(x-t) - 2y - \mu_k^{-1}(x+t),
\end{aligned}$$

as  $p \longrightarrow \infty$ . The fundamental matrix solution  $\psi(\nu)$  defined with a given set of poles  $\mu_1 \dots \mu_N$  and rational functions  $f_1 \dots f_N$  converges to the usual Minkowski space-time function  $\psi(\zeta)$  described in Section 4.1 with the same  $\mu_k$  and  $f_k$ . To be more precise, given a point  $q$  of  $\mathbb{U}_1$  then for each value of  $\zeta$ ,  $\psi(\nu)$  defines a value at  $q$  for all  $p$  sufficiently large, and this converges (pointwise) to  $\psi(\zeta)$ . It is also the case that the gauge potential corresponding to  $\psi(\nu)$  converges to the gauge potential corresponding to  $\psi(\zeta)$ .

The anti-deSitter solutions obtained as limiting cases of the  $N$  solitons described in Section 4.4 in the zero-curvature limit give the limiting cases in the Minkowski space-time, i.e. the two limiting processes are interchangeable. To see this, first recall that  $\psi$  is given in the anti-deSitter and Minkowski cases by expressions involving only  $\frac{\partial\gamma}{\partial\mu}$  which differ only in the definition of  $\gamma$  — for Minkowski space-time we shall take

$$\gamma = \mu(x-t) - 2y - \mu^{-1}(x+t)$$

(which differs by a factor of  $-2$  from the more usual definition given in Section 4.1) and in the anti-deSitter space-time it is

$$\gamma = \mu(x-t) - \frac{r^2}{p - \mu^{-1}(x+t)} + p.$$

Second the limit of  $\frac{\partial\gamma}{\partial\mu}$  in the anti-deSitter space-time case as  $p \longrightarrow \infty$  (with  $x$ ,  $t$ ,  $y$  and  $u$  fixed) is the corresponding Minkowski space-time quantity, since

$$\begin{aligned}
\frac{\partial\gamma}{\partial\mu} &= (x-t) - \frac{r^2}{(p - \mu^{-1}(x+t))^2} (x+t)\mu^{-2} \\
&= (x-t) - \frac{((p-y)^2 - s^2)}{(p - \mu^{-1}(x+t))^2} (x+t)\mu^{-2} \\
&\longrightarrow (x-t) + \mu^{-2}(x+t).
\end{aligned}$$



This last quantity is the Minkowski space-time quantity  $\frac{\partial\gamma}{\partial\mu}$ , which shows that the limits are interchangeable.

The second approach is to consider the solutions of the Bogomol'nyi equations in the  $(2+1)$ -dimensional anti-deSitter space-time and take a suitable limit. Recall that anti-deSitter space-time has constant curvature and scalar curvature  $-6$ . If one replaces the metric  $g$  with  $p^2g$  for some  $p > 0$  then the scalar curvature becomes  $-6/p^2$ . The Bogomol'nyi equations are then

$$D_t\Phi = -\frac{r}{p}F_{xr}, \quad D_x\Phi = +\frac{r}{p}F_{rt}, \quad D_r\Phi = +\frac{r}{p}F_{tx}.$$

If  $(A, \Phi)$  is a solution for metric  $g$ , then  $(A, \Phi/p)$  is a solution for metric  $p^2g$ . Of course we cannot just take a limit of a solution  $(A, \Phi/p)$  as  $p \rightarrow \infty$  — one obtains  $(A, 0)$ , which satisfies the limiting equation  $D_t\Phi = 0 \cdot F_{xr}$ . There is also the issue of recovering Minkowski space-time from the various curvature anti-deSitter space-times. The solution is first of all to consider a family of the  $N$ -solitons parameterised by  $p$  and increase the scale parameters  $a_k$  in proportion to  $p$ . We shall start with the  $N = 1$  case. Since  $\|\Phi\|$  is proportional to  $a = a_1$  this gives us a chance that our family of solutions will converge. However the apparent size of the base of the soliton in the  $AdS^{2+1}$  coordinates is proportional to  $1/a$ , so this family will not converge to a limit. However since the metric is proportional to  $p$  the actual size of the base tends to a constant. (One also has to make sure that the position of the soliton is chosen in a suitable way its distance from the origin of the  $p$  solution in the metric  $p^2g$  tends to a limit and the position in the rescaled coordinates tends to a limit).

Now we shall describe the general case for  $N$ -solitons in detail. We take the  $f_k$  to be functions of

$$\gamma_k = \mu_k(x - t) - \frac{r^2}{1 - \mu_k^{-1}(x + t)} + 1$$

and choose

$$f_k(\gamma_k) = pa_k\gamma_k + c_k$$

or more generally  $f_k(\gamma_k) = g_k(p\gamma_k)$  for rational functions  $g_k$ . One expresses the connection  $A$  and Higgs field  $\Phi$  in terms of the coordinates  $X, Y, s$ , then rescales

the Higgs field  $\Phi \rightarrow \Phi/b$  to obtain a solution on the scalar curvature  $-6/p^2$  space-time. If one rescales the coordinates so  $X \rightarrow X/2p$ ,  $Y \rightarrow Y/2p$ ,  $s \rightarrow s/p$  the metric

$$4p^2 \cos^2 s \frac{dX^2 + dY^2}{(1 - (X^2 + Y^2))^2} - p^2 ds^2$$

becomes

$$\cos^2(s/p) \frac{dX^2 + dY^2}{(1 - (X^2 + Y^2)/p^2)^2} - ds^2$$

so pointwise converges to the usual Minkowski space-time metric (identifying  $X$  with  $x$  and so on). Note that by rescaling,  $s$  becomes proper time again. If we take a limit as  $p \rightarrow \infty$  then  $A_X$ ,  $A_Y$ ,  $A_s$  and  $\Phi$  converge to the Minkowski space-time equivalents. In particular if one takes  $N = 1$ ,  $\mu = i$  and  $f(\gamma) = p\gamma$ , then in the limit as  $p \rightarrow \infty$  then the connection and gauge potential converge to their Minkowski equivalents if we take  $\mu = i$ ,  $f(\gamma) = \gamma$ . In particular

$$\|\Phi\|^2 \rightarrow 32 \frac{1}{(1 + 4X^2 + Y^2)^2},$$

which is the value of  $\|\Phi\|^2$  in the Minkowski case.

The two methods described are closely related, since under the isometry  $x \rightarrow px$ ,  $y \rightarrow py$ ,  $t \rightarrow pt$

$$\gamma = \mu(x - t) - \frac{r^2}{p - \mu^{-1}(x + t)} + p$$

becomes

$$p \left( \mu(x - t) - \frac{r^2}{1 - \mu^{-1}(x + t)} + 1 \right).$$

So the first method can be thought of as taking a limit as the scale parameter tends to infinity as we did in the second method.



# Chapter 5

## Hyperbolic Monopoles

In this chapter we shall construct explicit examples of hyperbolic monopoles. Hyperbolic monopoles are topological solitons which are Yang-Mills-Higgs configurations on a constant curvature space  $H^3$  with negative scalar curvature, analogous to the monopoles described on  $\mathbb{E}^3$  previously. They are solutions to the Bogomol'nyi equation on  $H^3$  subject to suitable boundary conditions and are local minima of the Yang-Mills-Higgs energy density on  $H^3$ . Solutions of the Bogomol'nyi equations correspond to solutions of the ASDYM invariant under a 1-dimensional group of rotations and so the Bogomol'nyi equations are integrable. Atiyah first considered hyperbolic monopoles in [20] and observed that they correspond to rotationally-invariant instantons, at least when the asymptotic value of the Higgs field  $p$  is an integer. One reason for studying hyperbolic monopoles is that they are often easier to find and their solutions can be expressed explicitly in simple forms using rational functions. Also it was suggested by Atiyah that Euclidean solutions can be recovered from the hyperbolic case by taking a suitable limit as the scalar curvature tends to zero. By a rescaling argument this corresponds to taking a limit as  $p$  tends to infinity. Some rigorous results have been established in this area by Jarvis and Norbury [50].

We shall construct a number of solutions in the case  $p = 1/2$ . Apart from the 1-monopole sector which is well-known, these include a 7-parameter family of 2-monopole solutions, axially-symmetric monopoles of arbitrary charge and higher-

charge configurations.

## 5.1 Hyperbolic Monopoles and Instantons

Recall that hyperbolic 3-space is the open upper half-space

$$H^3 = \{(x, y, r) \in \mathbb{R}^3 : r > 0\}$$

equipped with the metric

$$ds^2 = a^2 \frac{dx^2 + dy^2 + dr^2}{r^2}.$$

This is a manifold of constant curvature and (constant) scalar curvature  $-6/a^2$ . The geodesics are semi-circles meeting the plane  $r = 0$  perpendicularly (along with the limiting case of half-lines parallel to the  $r$ -axis) and has volume form

$$\Omega = (a/r)^3 dx \wedge dy \wedge dr.$$

It is isometric to the ball of radius  $2a$  in  $\mathbb{R}^3$  with metric  $(1 - (x^2 + y^2 + z^2)/4a^2)^{-2}(dx^2 + dy^2 + dz^2)$ . In this case the geodesics are semi-circles meeting the sphere at infinity perpendicularly with a limiting case of a straight line segment through the origin. From now on we will concentrate on the case  $a = 1$ .

The Bogomol'nyi equation on  $H^3$  is  $D\Phi = -*F$ , where  $F$  is the curvature of a connection  $A$ ,  $\Phi$  is a section of the adjoint bundle,  $D\Phi$  is the covariant derivative with respect to  $A$  and  $*$  is the Hodge star relative to the metric on  $H^3$ . Explicitly the equation is

$$D_x \Phi = -r F_{yr}, \quad D_y \Phi = -r F_{rx}, \quad D_r \Phi = -r F_{xy}.$$

Hyperbolic monopoles are solutions of the Bogomol'nyi equation subject to certain boundary conditions, the principal one being that the asymptotic value of the norm of the Higgs field  $p$  is a fixed positive number. Also the energy

$$\int (F \wedge *F + D\Phi^* D\Phi) \equiv \int \mathcal{E} \Omega \tag{5.1}$$

is finite, where bracket denote the inner product and  $\mathcal{E}$  is energy density. The Bogomol'nyi argument used in Section 1.1 goes through in the hyperbolic case just as in the Euclidean case. So solutions of the Bogomol'nyi equations are local minima of  $\mathcal{E}$ .

In this thesis we shall deal exclusively with  $SU(2)$  monopoles using inner product  $(A, B) = -(1/2) \text{tr}(AB)$  and its norm  $\|A\|^2 = -(1/2)A^2$ . The monopoles are classified by a topological charge  $n$  given by

$$\frac{1}{4\pi p} \int -\text{tr} D\Phi \wedge F,$$

which can be thought of as an element  $\pi_2(SU(2))$ .

Consider an anti-self-dual connection  $W$  on Euclidean space  $\mathbb{E}^4$  with curvature  $G$ , so  $*G = -G$ , where  $*$  is defined with respect to the Euclidean metric. Recall that instanton solutions have finite Euclidean action

$$\int -\frac{1}{2} \text{tr}(G \wedge *G),$$

that this implies that the connection extends to a bundle over the conformal compactification  $S^4$ , and instantons are classified by a topological charge which is the second Chern class of the bundle over  $S^4$  and is given by

$$c_2 = \frac{1}{8\pi^2} \int -\text{tr}(G \wedge G).$$

Recall also that if  $x_0, \dots, x_3$  are the standard coordinates on  $\mathbb{E}^4$  then putting  $x_0 = x$ ,  $x_1 = y$  and choosing polar coordinates  $(r, \theta)$  in the  $(x_2, x_3)$ -plane the Euclidean metric becomes

$$ds^2 = r^2 \left( \frac{dx^2 + dy^2 + dr^2}{r^2} + d\theta^2 \right),$$

and thus  $\mathbb{E}^4$  with the plane  $r = 0$  removed is conformally equivalent to the product of hyperbolic space  $H^3$  and the circle  $S^1$ . Atiyah observed [20] that it follows that  $S^1$ -invariant ASDYM fields correspond to solutions of the Bogomol'nyi equations on  $H^3$  and moreover that instantons correspond to finite energy solutions — we described this reduction in Section 2.3. We (locally) choose a gauge in which the components  $W_x, W_y, W_r$  and  $W_\theta$  are independent of  $\theta$  and put  $W_x = A_x, W_y = A_y, W_r = A_r$  and  $W_\theta = \Phi$ . Then  $F_{xy} = G_{xy}$  and  $D_x\Phi = G_{x\theta}$  and so on. This is analogous to

Euclidean monopoles, which correspond to translation-invariant ASDYM fields, but with infinite action. Recall that there is however one subtlety here not present in the translation-invariant case. The notion of  $S^1$ -invariance of  $W$  involves lifting the  $S^1$ -action on  $\mathbb{E}^4$  to an action on the principal bundle on which  $W$  is defined. If we restrict our attention to the gauge group  $SU(2)$  work with the bundle  $V$  associated to the fundamental representation of  $SU(2)$  we must now lift the action to one on  $V$ . Such an action, on restriction to the plane  $r = 0$ , is (up to conjugacy)

$$\alpha \rightarrow \begin{pmatrix} e^{ip\alpha} & 0 \\ 0 & e^{-ip\alpha} \end{pmatrix},$$

for some integer  $p$ , where  $\alpha$  is the angle of rotation. Thus the possible lifts of the  $S^1$ -action are classified topologically by the integer  $p$ . In fact  $p$  is the asymptotic value of the norm of the Higgs field as  $r$  tends to zero. This is because the Higgs field is the difference between the covariant and Lie derivatives in the  $\theta$  direction. From the expressions for monopole charge  $n$  and instanton number we see immediately that  $c_2 = 2pn$ .

The strict notion of an  $S^1$ -invariant instanton implies that  $p$  is an integer and the instanton number is even. Nash [51] pointed out that hyperbolic monopoles with half-integral  $p$  correspond to instantons with odd instanton number (we will be interested especially in the case  $p = 1/2$ ) and we shall also refer to these as  $S^1$ -invariant instantons even though under a  $2\pi$  rotation  $A$  is transformed to  $-A$ . The final possibility is that  $p$  be neither integral nor half-integral. Such a monopole corresponds to an ASDYM field which does not extend to the plane  $r = 0$  and these have been considered, for example, by Murray and Singer [55].

Atiyah considered integral hyperbolic monopoles and the corresponding vector bundles, both over the full twistor space, which is  $\mathbb{CP}^3$ , and over minitwistor space. The minitwistor space is  $\mathbb{CP}^1 \times \mathbb{CP}^1$  (see Sections 2.3 and 2.4). This space can be identified with the space of oriented geodesics, with the orientation reversed by the real structure  $\sigma(\lambda, \omega) = (\bar{\omega}, \bar{\lambda})$ , which corresponds to the real structure  $\sigma_3$  in Section 2.3. To see this, we can identify a point  $\lambda \in \mathbb{CP}^1$  with the point  $(\operatorname{Re} \lambda, \operatorname{Im} \lambda, 0)$  in the plane  $r = 0$ , and one can think of the first factor in the minitwistor space as the

plane  $r = 0$  together with a point at infinity in the open upper half-plane model (or the boundary sphere in the ball model). It is straightforward to show that a point  $(\lambda_1, \bar{\lambda}_2)$  in the minitwistor space corresponds to the geodesic which meets  $r = 0$  in the points given by  $\lambda_1$  and  $\lambda_2$  using the minitwistor correspondence. Clearly the real structure swaps the corresponding end points and so can be thought of as changing the orientation. The points of the form  $(\lambda, \bar{\lambda})$  are mapped to themselves by the real structure, that is to say the set of such points forms the real twistor space and corresponds to the plane  $r = 0$  in the open upper half-space model (and of course the boundary sphere in the ball model).

Atiyah obtained a number of results for hyperbolic monopole bundles both over the full twistor space and over the minitwistor space. In particular the bundle  $E'$  over minitwistor space has two splittings

$$0 \longrightarrow \mathcal{L}^+ \longrightarrow E' \longrightarrow (\mathcal{L}^+)^* \longrightarrow 0,$$

$$0 \longrightarrow \mathcal{L}^- \longrightarrow E' \longrightarrow (\mathcal{L}^-)^* \longrightarrow 0,$$

where  $\mathcal{L}^+$ ,  $\mathcal{L}^-$  are line bundles equivalent to  $H_+^{-p-k} \otimes H_-^p$ ,  $H_+^{-p} \otimes H_-^{-p-k}$  respectively, where  $H_+$  ( $H_-$ ) is the pull-back to  $\mathbb{CP}^1 \times \mathbb{CP}^1$  of the Hopf line-bundle under the projection map onto the first (second) factor of the product. (The Hopf line bundle is the line bundle whose fibre above a point of  $\mathbb{CP}^1$  is the corresponding 1-dimensional subspace of  $\mathbb{C}^2$ ). Atiyah showed that the monopole is determined by a spectral curve as in the Euclidean case.

Atiyah also gave a rational map description of hyperbolic monopoles. One considers solutions of  $(D_\rho + i\Phi)s = 0$  where  $\rho = \log r$ . There are solutions  $s_\pm$  which are asymptotic to  $\exp(\pm p\rho)$  as  $\rho \rightarrow -\infty$  and similar solutions  $s'_\pm$  as  $\rho \rightarrow +\infty$ . Writing  $s_+ = as'_+ + bs'_-$  one defines the rational map by  $f(x + iy) = a/b$ . Under this description, hyperbolic  $n$ -monopoles correspond to based rational maps of degree  $n$ . This method involves choosing a direction in  $H^3$ , namely that of the  $r$ -axis, and of course one could have chosen any other direction. Just as in the Euclidean case there is a Jarvis rational map description involving fixing a point  $P$  and considering  $(D_u + i\Phi)s = 0$  on lines through  $P$  with unit tangent  $u$ .

Nash [51] constructed examples of the 1-monopole sector explicitly using the ball model and by taking solutions of the form

$$A_i = -\frac{(P-1)}{R^3} \epsilon_{ijk} x^j \frac{\sigma_j}{2i}, \quad \Phi = \frac{Q}{R} x^i \frac{\sigma_j}{2i},$$

where  $R^2 = x^i x_i$ . He found,

$$P = \frac{B \sinh s}{\sinh Bs}, \quad Q = \frac{1}{P} \frac{dP}{ds},$$

where  $s = 2 \tanh^{-1} R/2$  is the (hyperbolic) distance from the centre of the ball and  $B-1$  is (with our conventions for the norm of  $\Phi$ ) twice the asymptotic value of the norm of the Higgs field. Nash also described these solutions in terms of the corresponding instantons in the case that  $p$  is integral or half-integral. The instantons can be obtained from the t'Hooft ansatz by taking  $2p+1$  equally weighted singularities equally spaced on a circle of radius 2 around the plane of rotation. This gives an  $S^1$ -invariant instanton despite the fact that the solution of the Laplace equation is not rotationally invariant. These solutions were also constructed by Chakrabati [52] using a traditional integrable systems approach and a number of complicated coordinate transformations.

There are a number of other papers on hyperbolic monopoles, including the following. Braam and Austin [53] have considered integral and in particular half-integral hyperbolic monopoles as invariant instantons using the ADHM construction. The analogue of the Nahm equation is discrete, being defined on a lattice of  $2p+1$  points. They also showed that the monopole is determined by its asymptotic value on the boundary sphere, i.e. by the restriction of the instanton connection on  $S^4$  to the invariant  $S^2$ .

Murray and Singer [55] generalised the twistor description to non-integral  $p$  showing that hyperbolic monopoles correspond to bundles over a twistor space which is  $\mathbb{CP}^1 \times \mathbb{CP}^1$  minus the diagonal corresponding to the real twistor space. They generalised some of Atiyah's results for integral  $p$ , namely the existence of two splittings for the monopole bundle and the fact that the monopole is determined by its spectral curve.

Jarvis and Norbury [50] showed that the limit of the Jarvis rational map for

hyperbolic monopoles is the Jarvis map for Euclidean monopoles.

Sutcliffe and Ioannidou [54] have constructed some interesting solutions for higher gauge groups.

## 5.2 An Ansatz for Hyperbolic Monopoles

In this section we will construct an ansatz for hyperbolic monopoles in the case  $p = 1/2$ , by considering the corresponding instantons. We saw in Section 2.5 that in general the problem of constructing instantons is a difficult one. The simplest and best-known class of solutions is that of solutions obtained from the t'Hooft ansatz

$$W_\mu = i\tilde{\sigma}_{\mu\nu}\partial^\mu \log \phi. \quad (5.2)$$

Here the  $\tilde{\sigma}_{\mu\nu}$  are multiples of Pauli matrices, satisfying  $\tilde{\sigma}_{\mu\nu} = -\tilde{\sigma}_{\nu\mu}$ , which are self-dual (i.e.  $\tilde{\sigma}_{\mu\nu} = (1/2)\epsilon_{\mu\nu\kappa\lambda}\tilde{\sigma}^{\kappa\lambda}$ ). Explicitly we shall take

$$\begin{aligned} \tilde{\sigma}_{01} &= \tilde{\sigma}_{23} = \frac{1}{2}\sigma_3, \\ \tilde{\sigma}_{02} &= -\tilde{\sigma}_{13} = -\frac{1}{2}\sigma_2, \\ \tilde{\sigma}_{03} &= \tilde{\sigma}_{12} = \frac{1}{2}\sigma_1. \end{aligned} \quad (5.3)$$

The gauge potential satisfies the ASDYM equation if  $\phi$  satisfies Laplace's equation on  $\mathbb{E}^4$ . To get the correct boundary conditions  $\phi$  is of the form

$$\phi = \sum_{\alpha=0}^{c_2} \frac{\lambda_\alpha}{|x - x_\alpha|^2}, \quad (5.4)$$

where  $x_0 \dots x_{c_2}$  are (distinct) points in  $\mathbb{E}^4$  and  $\lambda_0 \dots \lambda_{c_2}$  are positive real numbers and  $|x|$  is distance in  $\mathbb{E}^4$ . As a special case we may choose one of the singularities to be the point at infinity

$$\phi = 1 + \sum_{\alpha=1}^{c_2} \frac{\lambda_\alpha}{|x - x_\alpha|^2}. \quad (5.5)$$

A 1-monopole corresponds to an instanton of topological charge  $2p$ . To construct such an instanton Nash [51] suggested using the t'Hooft ansatz and choosing the  $2p + 1$  singularities to be equally spaced on the circle  $x = 0, y = 0, r = 2$ .

Instead we shall restrict our attention to the case  $p = 1/2$ . To construct the corresponding instanton we assume that the singularities of  $\phi$  all lie in the plane  $r = 0$  (including the special case that one of the singularities is at infinity). Thus the derivative  $\phi_\theta = 0$ . This idea was suggested by Chakrabati in [52].

We shall use letters  $i, j, k$  and so on taking values 1, 2, 3 to label coordinates  $x, y, r$ . Thus  $W_3$  will refer to  $W_r$  in this context. The t'Hooft ansatz becomes

$$\begin{aligned} W_i &= -\frac{1}{2i}\epsilon_{ijk}L_j\sigma'_k, & i = 1, 2, 3 \\ W_\theta &= \frac{1}{2i}rL_i\sigma'_i, \end{aligned}$$

where  $L$  is  $\log \phi$ ,  $L_i$  refers to the derivative in the  $i$ -direction,

$$\begin{aligned} \sigma'_1 &= \cos \theta \sigma_1 + \sin \theta \sigma_2 \\ \sigma'_2 &= -\sin \theta \sigma_2 + \cos \theta \sigma_1 \end{aligned}$$

and  $\sigma'_3 = \sigma_3$ . If  $g = \exp \frac{\sigma}{2i}\theta$ , then under the gauge transformation corresponding to  $g$

$$W_i \rightarrow g^{-1}W_i g, \quad i = 1, 2, 3$$

and

$$W_\theta \rightarrow g^{-1}W_\theta g + g^{-1}\partial_\theta g.$$

(Again this transformation appears in [52].) If we put  $W_\theta = \Phi$ ,  $W_i = A_i$  and  $\tau_j = \frac{\sigma_j}{2i}$ , then we obtain the ansatz

$$A_i = -\epsilon_{ijk}L_j\tau_k, \quad i = 1, 2, 3 \tag{5.6}$$

$$\Phi = rL_i\tau_i + \tau_3. \tag{5.7}$$

In polar coordinates the (Laplace) equation for  $\phi$  is

$$\phi_{xx} + \phi_{yy} + \phi_{rr} + \frac{1}{r}\phi_r = 0$$

or in terms of  $L$

$$L_{xx} + L_{yy} + L_{rr} + \frac{1}{r}L_r + (L_x^2 + L_y^2 + L_r^2) = 0.$$



Notice that this implies that

$$\begin{aligned}
\|\Phi\|^2 &= \frac{1}{4} \left( (rL_x)^2 + (rL_y)^2 + (rL_r + 1)^2 \right) \\
&= \frac{1}{4} \left( 1 - r^2(L_{xx} + L_{yy} + L_{rr} - \frac{1}{r}L_r) \right) \\
&= \frac{1}{4}(1 - \Delta L),
\end{aligned}$$

where  $\Delta$  is the Laplacian on  $H^3$ .

### 5.3 1-Monopole Solutions

In this section the 1-monopole solutions are constructed using the ansatz above. To do this  $\phi$  must have two singularities. Take one singularity in  $\phi$  to be at  $\infty$  and one in the plane  $r = 0$ . By performing a translation we can assume that the second singularity is at  $x = 0, y = 0$ . In other words

$$\phi = 1 + \frac{\lambda}{x^2 + y^2 + r^2}.$$

Then the gauge potential is

$$A_i = \frac{2\lambda\epsilon_{ijk}x_j\tau_k}{(x^2 + y^2 + r^2 + \lambda)(x^2 + y^2 + r^2)},$$

and the Higgs field is

$$\Phi = \frac{-2\lambda r x_i \tau_i}{(x^2 + y^2 + r^2 + \lambda)(x^2 + y^2 + r^2)} + \tau_3.$$

The square of the norm of the Higgs field is

$$\frac{1}{4} - \frac{\lambda r^2}{(x^2 + y^2 + r^2 + \lambda)^2}, \tag{5.8}$$

and the energy density  $\mathcal{E}$  is

$$\frac{24\lambda^2 r^4}{(x^2 + y^2 + r^2 + \lambda)^4}. \tag{5.9}$$

The definition of the position of a monopoles is usually taken to be where the Higgs field vanishes, and here this happens at  $x = 0, y = 0$  and  $r = \sqrt{\lambda}$ . Note that the energy takes its maximum value there also. As  $r$  tends to infinity the norm of

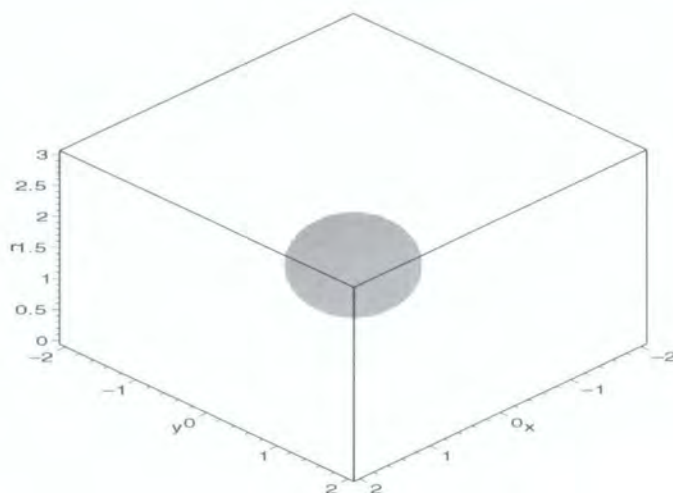

Figure 5.1: A monopole of charge 1.

the Higgs tends to  $1/2$  as expected. Figure 5.1 shows a plot of a surface of constant energy for a 1-monopole (in the upper half-space model). Of course this solution is the analogue of the Euclidean 1-monopole.

An alternative is to take both singularities in the plane  $r = 0$ . Let

$$\phi = \frac{\lambda}{(x+a)^2 + y^2 + r^2} + \frac{1}{(x-a)^2 + y^2 + r^2}. \quad (5.10)$$

Then we obtain a 1-monopole at  $x = a(-1 + \lambda)/(1 + \lambda)$ ,  $y = 0$ ,  $r = 2a\sqrt{\lambda}/(1 + \lambda)$ . Notice that in both cases the zero of the monopole lies on the geodesic joining the two singularities,  $r = 0$  in the first case and  $x^2 + r^2 = a^2$  in the second. The position on this geodesic is determined by the weight  $\lambda$ .

## 5.4 2-Monopole Solutions

Consider  $\phi$  of the form

$$\phi = 1 + \frac{\lambda}{(x-a)^2 + y^2 + r^2} + \frac{\mu}{(z+a)^2 + y^2 + r^2}. \quad (5.11)$$

For the most we will be concerned with the case  $\lambda = \mu$ . There are 3 main possibilities.

$a^2 > \lambda/4$

For large  $a$  this represents two monopoles at approximately  $x = a, y = 0, r = \sqrt{\lambda}$  and  $x = -a, y = 0, r = \sqrt{\lambda}$  (or more generally  $r = \sqrt{\mu}$ ), see the first plot of Figure 5.2. As  $a^2$  approaches  $\lambda/4$  the monopoles begin to interact with each other and this description begins to break down (Plot ii).

$$\underline{a^2 = \lambda/4}$$

The Higgs field has a double zero at  $x = 0, y = 0, r^2 = 3\lambda/4$ . This is the analogue of the charge 2 solution of Ward [25] described in Example 2.4 (Plot iii).

$$\underline{a^2 < \lambda/4}$$

In this case the Higgs field has 2 zeros lying on the  $r$ -axis at

$$r = \sqrt{-a^2 + \lambda \pm \sqrt{-4\lambda a^2 + \lambda^2}}$$

(see Plots iv and v). Notice that although one monopole looks much larger than the other this is due to the factor of  $r^{-3}$  in the volume form. Rotating this solution in the  $(x, y)$ -plane gives a 1-parameter family of gauge inequivalent solutions, all with the same zeros. This is the same as the Euclidean case, where, for a choice of the two positions of the zeros of the Higgs field, there is again a family of gauge inequivalent solutions parameterised by a relative internal phase. Moreover we can apply isometries to a family of solutions parameterised by the distance between the two monopoles (including the two monopole solution). I believe this generates the whole 2-monopole space, but this requires some proof.

We could of course take all 3 singularities away from infinity in the plane  $r = 0$ . Particularly interesting is to take the singularities to be the vertices of an equilateral triangle:

$$\phi = \frac{1}{(x-a)^2 + y^2 + r^2} + \frac{1}{(x + \frac{1}{2}a)^2 + (y - \frac{\sqrt{3}}{2}a)^2 + r^2} + \frac{1}{(x + \frac{1}{2}a)^2 + (y + \frac{\sqrt{3}}{2}a)^2 + r^2}.$$

If  $\rho$  is radial distance in the  $xy$ -plane, then

$$\|\Phi\|^2 = \frac{1}{4} \left( 1 - \frac{a^2 r^2 (3K_+^2 - 2K_+ K_- + 3K_-^2)}{K_+^2 K_-^2} \right),$$

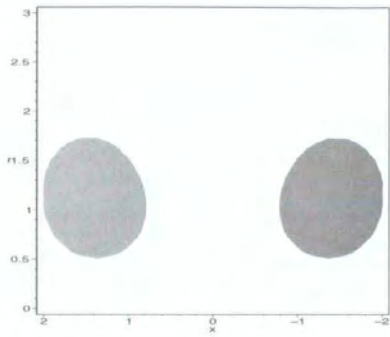

Plot i

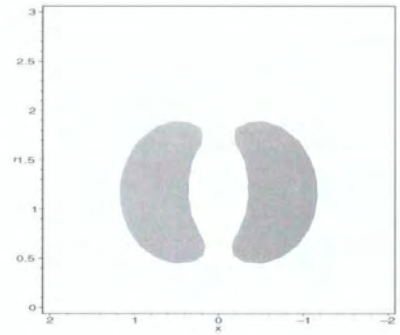

Plot ii

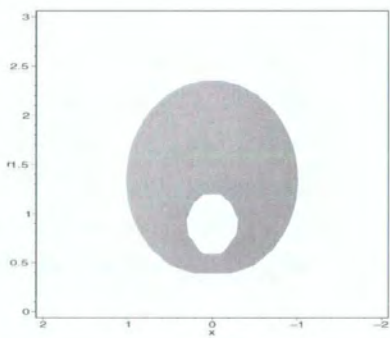

Plot iii

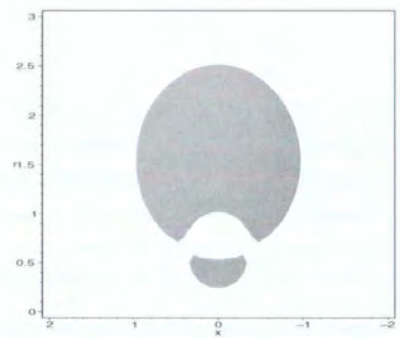

Plot iv

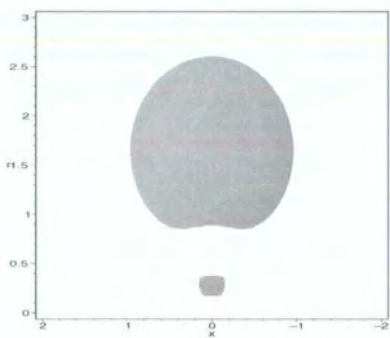

Plot v

Figure 5.2: A number of 2-monopole solutions.

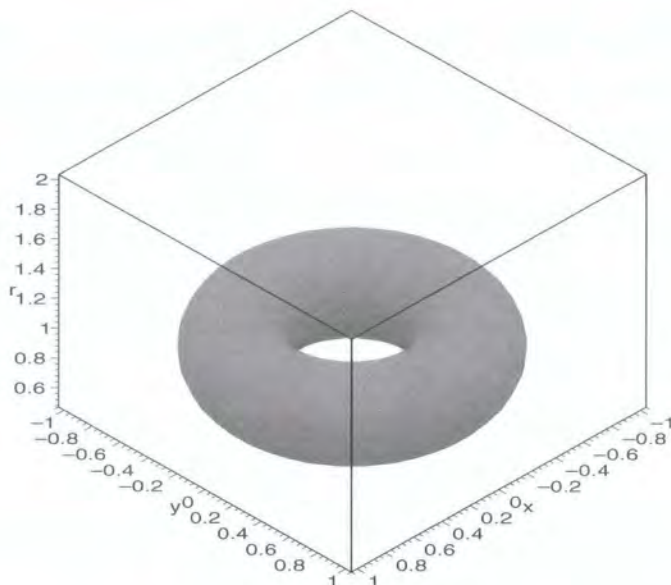

Figure 5.3: An axially-symmetric monopole of charge 2.

and

$$\mathcal{E} = \frac{a^4 r^4 (27K_+^4 - 12K_+^3 K_- - 14K_+^2 K_-^2 - 12K_+ K_-^3 + 27K_-^4)}{K_+^4 K_-^4},$$

where  $K_{\pm} = (r^2 + a^2 \pm a\rho + \rho^2)$ . This solution is again the hyperbolic version of Ward's toroidal 2-monopole solution and is shown in Figure 5.3.

## 5.5 Higher-charge Monopoles

By analogy with Euclidean monopoles we expect the moduli space of hyperbolic monopoles of charge  $n$  to be a  $(4n - 1)$ -manifold. Since the ansatz of Section 5.2 has  $3n + 2$  parameters and thus we can hope at best to use it to construct the 1-monopole, 2-monopole and possibly 3-monopole sectors, but in general the problem of finding the data for a given monopole seems intractable. However we can still use our ansatz to find a number of interesting solutions.

We may generalise the construction of the previous section and choose  $n + 1$  singularities ( $n > 1$ ) equally spaced on the circle  $r = 0$ ,  $\rho = a$  and with equal weights. This represents a charge- $n$  torus, analogous to the solution of Prasad and Rossi [26], whose Higgs field has one  $n$ -fold zero on the  $r$ -axis at  $r = a$ . For example,

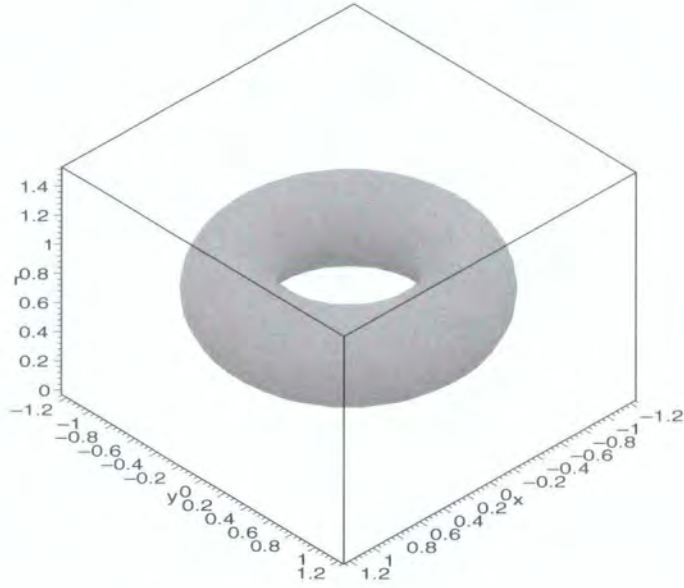

Figure 5.4: An axially-symmetric monopole of charge 3.

if

$$\phi = \frac{1}{(x-a)^2 + y^2 + r^2} + \frac{1}{(x+a)^2 + y^2 + r^2} + \frac{1}{x^2 + (y-a)^2 + r^2} + \frac{1}{x^2 + (y+a)^2 + r^2},$$

then this is a charge 3 torus whose Higgs field has its zero on the  $r$ -axis at  $r = a$  (Figure 5.4), and

$$\|\Phi\|^2 = \frac{1}{4} - \frac{4a^2 r^2 (K_+^2 - 2K_+ K_- + 5K_-^2)(5K_+^2 - 2K_+ K_- + K_-^2)}{(K_+ + K_-)^2 (K_+^2 - 6K_+ K_- + K_-^2)^2}.$$

One final solution is to take

$$\phi = 1 + \frac{1}{(x-a)^2 + y^2 + r^2} + \frac{1}{(x + \frac{1}{2}a)^2 + (y - \frac{\sqrt{3}}{2}a)^2 + r^2} + \frac{1}{(x + \frac{1}{2}a)^2 + (y + \frac{\sqrt{3}}{2}a)^2 + r^2}.$$

For  $a^2 < 3\lambda/8$  this represents a configuration of a toroidal 2-monopole and a 1-monopole (Figure 5.5).



Figure 5.5: A 2-monopole / 1-monopole configuration .

## 5.6 Ansätze for Higher- $p$ Monopoles

One of the most obvious questions we might ask is whether we can find solutions for higher  $p$ . Our ansatz for  $p = 1/2$  came from assuming that the solutions of the Laplace equation  $\phi$  used in the t'Hooft ansatz were  $S^1$ -invariant. The gauge transformation  $g = \exp(\sigma_3/(2i))$  gives rise to a term  $\sigma_3/(2i)$  in the expression for  $\Phi$  which for appropriate  $\phi$  ensures that  $\|\Phi\| = 1/2$  at infinity. One possible approach to higher  $p$  solutions would be to consider using  $S^1$ -invariant helicity- $(l - 1)$  fields in higher ansätze  $\mathcal{A}_l$ ,  $l \geq 2$ . It should be pointed out that it is not necessary to use rotationally-invariant fields in the ansätze to get rotationally-invariant gauge fields, the solution of Nash for  $\mathcal{A}_1$  where  $\phi$  has equally-spaced, equally-weighted singularities around the invariant plane is a prime example. However this approach might prove fruitful as with the  $p = 1/2$  case.

Consider the ansatz  $\mathcal{A}_l$  (see Section 2.5). Put  $\tilde{z} = x + iy$ ,  $z = x - iy$ ,  $w = re^{i\theta}$ ,  $\tilde{w} = -re^{-i\theta}$ , so that  $S^1$ -invariant connections are invariant under the transformation generated by  $X = w\partial_w - \tilde{w}\partial_{\tilde{w}}$ . Take  $f = 0$ ,  $l = 2p$  and suppose  $\Gamma$  is a function of the minitwistor variables  $\lambda$ ,  $\omega$  only. Consider the Laurent expansion of  $\Gamma$

$$\Gamma = \sum_{s=-\infty}^{\infty} \Delta_s \zeta^s$$

for functions  $\Delta_s$  of  $x$ ,  $y$ ,  $r$ ,  $\theta$ . Since  $\lambda = r\sigma + x + iy$ ,  $\omega = -r/\sigma + x - iy$ , where

$\sigma = \zeta e^{i\theta}$  is the invariant spectral parameter, one can write

$$\Gamma = \sum_{s=-\infty}^{\infty} \tilde{\Delta}_s \sigma^s,$$

where the  $\tilde{\Delta}_s$  are functions of  $x$ ,  $y$  and  $r$  only and thus  $\Delta_s = \tilde{\Delta}_s e^{-is\theta}$ . The inverse of the banded matrix

$$M = \begin{pmatrix} \Delta_{-2p+1} & \cdots & \Delta_0 \\ \vdots & \ddots & \vdots \\ \Delta_0 & \cdots & \Delta_{2p-1} \end{pmatrix}$$

is then given by

$$(M^{-1})_{ij} = (\tilde{M}^{-1})_{ij} e^{-i(2p+1-i-j)\theta},$$

where

$$\tilde{M} = \begin{pmatrix} \tilde{\Delta}_{-2p+1} & \cdots & \tilde{\Delta}_0 \\ \vdots & \ddots & \vdots \\ \tilde{\Delta}_0 & \cdots & \tilde{\Delta}_{2p-1} \end{pmatrix}.$$

In particular the corner elements  $E = (M^{-1})_{11}$ ,  $F = (M^{-1})_{1,2p}$ ,  $G = (M^{-1})_{2p,2p}$  are given by

$$E = \tilde{E} e^{-i(2p-1)\theta}, \quad (5.12)$$

$$F = \tilde{F}, \quad (5.13)$$

$$G = \tilde{G} e^{i(2p-1)\theta}. \quad (5.14)$$

In the coordinates  $x$ ,  $y$ ,  $r$  and  $\theta$  the gauge potential in the R-gauge is

$$A_x = \frac{1}{2F} \begin{pmatrix} iF_y & -e^{-i\theta}(E_r + \frac{1}{ir}E_\theta) \\ -e^{i\theta}(-G_r + \frac{1}{ir}G_\theta) & -iF_y \end{pmatrix},$$

$$A_y = \frac{1}{2F} \begin{pmatrix} -iF_x & -ie^{-i\theta}(E_r + \frac{1}{ir}E_\theta) \\ ie^{i\theta}(-G_r + \frac{1}{ir}G_\theta) & iF_x \end{pmatrix},$$

$$A_r = \frac{1}{2F} \begin{pmatrix} \frac{1}{ir}F_\theta & e^{-i\theta}(E_x + iE_y) \\ -e^{i\theta}(G_x - iG_y) & -\frac{1}{ir}F_\theta \end{pmatrix},$$

$$A_\theta = \frac{1}{2F} \begin{pmatrix} irF_r & -ire^{-i\theta}(\tilde{E}_x + i\tilde{E}_y) \\ -ire^{i\theta}(\tilde{G}_x - i\tilde{G}_y) & -irF_r \end{pmatrix}.$$



Using (5.12) to (5.14) and applying the gauge transformation with  $g = \exp(p\sigma_3/(2i))$  these become

$$\begin{aligned} A_x &= \frac{1}{2F} \begin{pmatrix} iF_y & -\tilde{E}_r + \frac{2p-1}{r}\tilde{E} \\ \tilde{G}_r + \frac{2p-1}{r}\tilde{G} & -iF_y \end{pmatrix}, \\ A_y &= \frac{1}{2F} \begin{pmatrix} -iF_x & -i\tilde{E}_r + i\frac{2p-1}{r}\tilde{E} \\ -i\tilde{G}_r - i\frac{2p-1}{r}\tilde{G} & iF_x \end{pmatrix}, \\ A_r &= \frac{1}{2F} \begin{pmatrix} 0 & (\tilde{E}_x + i\tilde{E}_y) \\ -(\tilde{G}_x - i\tilde{G}_y) & 0 \end{pmatrix}, \end{aligned}$$

and

$$A_\theta = \frac{1}{2F} \begin{pmatrix} irF_r & -ir(\tilde{E}_x + i\tilde{E}_y) \\ -ir(\tilde{G}_x - i\tilde{G}_y) & -irF_r \end{pmatrix} + \begin{pmatrix} -\frac{ip}{2} & 0 \\ 0 & \frac{ip}{2} \end{pmatrix}.$$

If we take the reality condition  $\Gamma = \Gamma^\dagger$ , i.e.  $\Gamma(\lambda, \omega) = \Gamma(\bar{\lambda}, \bar{\omega})$ , so that

$$\overline{\Delta_s} = (-1)^s \overline{\Delta_{-s}},$$

then if we assume that  $2p$  is odd then  $F$  is real and  $\overline{\tilde{E}} = \tilde{G}$ . If we put  $\tilde{E} - \frac{2p-1}{r}\tilde{E} = P + iQ$  and  $\tilde{G} + \frac{2p-1}{r}\tilde{G} = P - iQ$  for  $P, Q$  real then we obtain

$$\begin{aligned} A_x &= \frac{iF_y}{2F}\sigma_3 + \frac{iP_r}{2F}\sigma_2 - \frac{iQ_r}{2F}\sigma_1, \\ A_y &= \frac{iF_x}{2F}\sigma_3 - \frac{iP_r}{2F}\sigma_2 - \frac{iQ_r}{2F}\sigma_1, \\ A_r &= \frac{iQ_x + iP_y}{2F}\sigma_1 - \frac{iP_x - iQ_y}{2F}\sigma_2, \\ A_\theta &= \frac{1}{2} \left( \frac{rF_r}{r} - p \right) \sigma_3 - r \frac{P_x - Q_y}{2F} \sigma_1 - r \frac{P_x + Q_y}{2F} \sigma_2. \end{aligned}$$

After putting  $A_\theta = \Phi$  we have ansätze for  $SU(2)$ -valued for the Bogomol'nyi equations in  $H^3$ . If the derivatives of  $F, P$  and  $Q$  decay sufficiently rapidly then this solution will have asymptotic Higgs  $p$ . In particular when  $p = 1/2$  we recover the original ansatz presented in Section 5.2. So far however I have been unable to find solutions for  $p > 1/2$ .

# Chapter 6

## Outlook

In this thesis we have seen that the Bogomol'nyi equations on constant curvature space-time are integrable and constructed a number of solutions. The methods of solution have involved a number of interesting concepts and methods from many branches of mathematics, especially geometry. We have seen that much of the results for the flat cases extend to the curved cases, and that, in the case of anti-deSitter space-time, as for hyperbolic space, one can recover the flat case as a zero-curvature limit. The solutions we have constructed display a number of attractive 3-dimensional soliton solutions in the case of hyperbolic monopoles. In the anti-deSitter case there are many interesting solutions including solitons undergoing non-trivial scattering.

A number of further problems suggest themselves. In the anti-deSitter case one can construct a number of further solutions including higher poles. Ioannidou has also constructed some soliton-antisoliton solutions and more work could be done here. It would be interesting to see if one could construct a better “energy density” than the one constructed in this thesis, one whose integral was finite, perhaps using  $\psi(\lambda = 0)^{-1}$  in place of our  $J$ -matrix. It would also be interesting to consider alternative coordinate systems. In particular one could consider a coordinate system with 2 spatial coordinates and a proper time coordinate such that all geodesics corresponding to  $\mu = i$  represent points in space static with respect to the time coordinate, just as we have with Minkowski space-time.

We have not constructed solutions in the deSitter space-time although some have been constructed by Kotecha [57]. There is room for much more investigation into this case. In particular the zero curvature limit and non-trivial scatterings.

In the case of hyperbolic monopoles one might try to generalise the solutions here to higher half-integral  $p$  or to general values of  $p$ . One can also look at the zero-curvature limit and try to recover well-known or new Euclidean monopole configurations. One could also try to relate the solutions to other monopoles methods — bundles over minitwistor space, spectral curves, Nahm (Braam-Austin) equations and rational maps.

Beyond the Bogomol'nyi equations, there are many other integrable systems, soliton phenomena and other questions of nonlinear science which one can address. In particular, there are many more equations obtainable from the ASDYM equations and their generalisations which can be studied.

# Appendix A

## Vector Bundles and Connections

This appendix gathers the basic definitions of vectors bundles, connections and curvature which are used throughout this thesis. This material is discussed in more detail in [1], [2], [3] and [4].

### A.1 Vector Bundles

A smooth, rank- $k$ , real *vector bundle* over a smooth manifold  $M$  is a smooth manifold  $E$ , together with a smooth map  $\pi : E \rightarrow M$  onto  $M$ , such that for each point  $x \in M$  the *fibre*  $E_x = \pi^{-1}(x)$  has the structure of a real vector space and there is a cover of  $M$  by open sets  $\{U_\alpha : \alpha \in A\}$  together with diffeomorphisms  $h_\alpha : \pi^{-1}(U_\alpha) \rightarrow U_\alpha \times \mathbb{R}^k$  such that  $h_{\alpha|E_x}$  is linear. Essentially, it is a smooth family of vector spaces parameterised by  $M$ . The manifold  $M$  is called the *base space*,  $E$  the *total space*,  $\pi$  the *projection map* and the maps  $h_\alpha$  are called *local trivialisations*. If we replace real vector spaces with complex vector spaces then  $E$  is a complex vector bundle. If in addition  $M$  is a complex manifold, the projection map is holomorphic of maximal rank and the local trivialisations are biholomorphic equivalences then  $E$  is *holomorphic*. Unless otherwise stated we shall assume  $E$  is complex.

Given two sets  $U_\alpha, U_\beta$  in the cover with non-zero intersection, one can consider the functions  $h_\beta \circ h_\alpha^{-1} : U_\alpha \cap U_\beta \times \mathbb{C}^k \rightarrow U_\alpha \cap U_\beta \times \mathbb{C}^k$ . Under this function  $(x, v)$

is mapped to  $(x, g_{\beta\alpha}v)$  for matrix valued functions  $g_{\beta\alpha}$  on  $U_\alpha \cap U_\beta$  called *transition matrices*. On  $U_\alpha \cap U_\beta \cap U_\gamma$  the matrices satisfy

$$g_{\alpha\gamma}g_{\gamma\beta}g_{\beta\alpha} = \text{id}. \quad (\text{A.1})$$

Conversely, to define a vector bundle it is enough to give an open cover of  $M$  and transition matrices satisfying (A.1). If the matrices can be chosen to lie in a subgroup  $G$  of  $GL(n, \mathbb{C})$ , then  $G$  is said to be the structure group of  $E$ .

A *section* of  $E$  is a map  $s : M \rightarrow E$  satisfying  $\pi \circ s = \text{id}_M$ . If  $s$  is instead defined only on an open subset of  $M$  it is a local section and we denote by  $\Gamma(M, E)$  the set of sections of  $E$ . One can find local sections  $(e_1, \dots, e_k)$  which are linearly independent at each point. Such a choice of sections is called a *frame*. Given a local trivialisation  $h_\alpha$  there is an obvious choice of frame, namely the one consisting of the sections corresponding to the standard basis in  $\mathbb{C}^k$ . If  $(e_1, \dots, e_k)$  is a frame on  $U_\alpha$ ,  $(\tilde{e}_1, \dots, \tilde{e}_k)$  is a frame on  $U_\beta$  and  $g = g_{\beta\alpha}$  is the transition matrix then

$$\tilde{e}_\rho = g_\rho^\sigma e_\sigma.$$

A section  $s$  is then given locally by  $s = s^\rho e_\rho = \tilde{s}^\rho \tilde{e}_\rho$  with

$$s^\rho = g_\sigma^\rho \tilde{s}^\sigma = \tilde{s}^\rho \tilde{e}_\rho. \quad (\text{A.2})$$

Conversely, to define a (global) section of  $E$  it is enough to give functions  $\{s^\rho\}$  on each open set of the cover satisfying (A.2).

If  $E$  has extra structure, then one can reduce the structure group  $G$  of  $E$  to a proper subgroup of  $GL(n, \mathbb{C})$ . For example if  $E$  has a Hermitian structure (in other words a Hermitian inner product on each fibre) then we can take  $G$  to be  $U(k)$  by replacing frames with orthonormal ones by a Gram-Schmidt process.

Given vector bundles  $E, F$ , one can construct other bundles analogous to the various operations on vector spaces. For example, one can find the dual bundle  $E^*$  whose fibre at  $X$  is the dual space  $E_x^*$  of  $E_x$ , the direct sum and tensor product bundles  $E \oplus F$  and  $E \otimes F$  whose fibres are  $E_x \oplus F_x$  and  $E_x \otimes F_x$  respectively and the homomorphism bundle  $\text{Hom}(E, F)$  whose fibre is the set of homomorphisms  $\text{Hom}(E_x, F_x)$  from  $E_x$  to  $F_x$ . In particular, one can form the endomorphism bundle

$\text{End}(E) = \text{Hom}(E, E)$  which is isomorphic to  $E \otimes E^*$ . One can also consider symmetric and anti-symmetric tensor products to obtain the symmetric tensor bundles  $\odot^p E$ , exterior product bundles  $\bigwedge^p E$  and the exterior algebra bundle  $\bigwedge^* E$ .

The tangent bundle, the collection of tangent spaces at each point of a manifold, is an important example of a vector bundle. One can consider the tensor algebra of bundles obtained from  $TM$ , especially the cotangent bundle  $T^*M$  and its exterior product  $\bigwedge^p(M) = \bigwedge^p T^*M$ . Sections of  $\bigwedge^p(M)$  are called  $p$ -forms and the set of  $p$ -forms  $\Gamma(M, \bigwedge^p(M))$  is denoted  $\Omega^p(M)$ . One can form the tensor product bundle  $E \otimes \bigwedge^p(M)$  and consider its sections, the set of which  $\Gamma(M, E \otimes \bigwedge^p(M))$  is denoted  $\Omega^p(E)$ . Such a section  $\omega \in \Omega^p(E)$  is called an  $E$ -valued  $p$ -form and takes vector fields  $X_1, \dots, X_p$  to a section of  $E$ .

One final bundle construction is the pullback bundle. Given manifolds  $M, N$ , a smooth map  $f : M \rightarrow N$  and a bundle  $E$  over  $N$ , one can obtain a bundle  $f^*E$  over  $M$ , called the pullback bundle, whose fibre at  $x$  is  $E_{f(x)}$  and whose transition matrices  $h_{\alpha\beta}$  for the cover  $\{f^{-1}(U_\alpha) : \alpha \in A\}$  are given by  $h_{\alpha\beta}(x) = g_{\alpha\beta}(f(x))$ . In particular, if  $M$  is a submanifold of  $N$  and  $i : M \rightarrow N$  is the inclusion map then  $i^*E$  is the restriction of  $E$  to  $M$  denoted  $E|_M$ .

## A.2 Principal Bundles, Associated Bundles and the Adjoint Bundle

A principal bundle is an object analogous to a vector bundle whose fibre at a point  $x$  is a Lie group  $G$  (which we shall assume is a subgroup of  $GL(k, \mathbb{C})$ ) instead of a vector space. More precisely, a principal bundle over  $M$  is a smooth manifold  $P$  together with a smooth map  $\pi : P \rightarrow M$  such that the fibres  $P_x = \pi^{-1}(x)$  have the structure of a Lie group isomorphic to  $G$ .  $P$  has an open cover  $\{U_\alpha : \alpha \in A\}$  and diffeomorphisms (local trivialisations)  $h_\alpha : \pi^{-1}(U_\alpha) \rightarrow U_\alpha \times G$ . Under the maps  $h_\beta \circ h_\alpha^{-1} : U_\alpha \cap U_\beta \times G \rightarrow U_\alpha \cap U_\beta \times G$ ,  $(x, M)$  is mapped to  $(x, g_{\beta\alpha}M)$  for  $G$ -valued functions. Given a vector bundle  $E$  one can obtain a principal  $GL(k, \mathbb{C})$  bundle with the same transition matrices. If  $E$  has structure group  $G$  then one can

obviously form a principal  $G$  bundle.

Suppose one has a principal  $G$  bundle. Given a vector space  $V$  and a representation  $\rho : G \longrightarrow GL(V)$  of  $G$  one can define a bundle in a similar way as we did for vector and principal bundles by patching  $(x, v)$  to  $(x, \rho(g_{\beta\alpha})v)$ . Such a bundle is called an associated bundle and of course has fibre  $V$ . The most important examples for us are obtained by the fundamental and adjoint representations.

In the fundamental representation of a subgroup  $G$  of  $GL(k, \mathbb{C})$  the elements of  $G$  act on column  $k$ -vectors by left multiplication, i.e.  $\rho(g)v = gv$ . The associated bundle is just the vector bundle with transition matrices  $g_{\beta\alpha}$ .

If  $G$  is a Lie group with Lie algebra  $\mathfrak{g}$ , then for each  $g \in G$  one can define a map  $Ad_g \in GL(\mathfrak{g})$  by  $Ad_g(T) = gTg^{-1}$ . The associated bundle given by the representation  $g \longrightarrow Ad_g$  is called the adjoint bundle. If  $P$  is obtained from a vector bundle  $E$ , we shall denote the adjoint bundle by  $\text{adj}(E)$ . The bundle is patched by mapping  $(x, T)$  to  $(x, g_{\beta\alpha}Tg_{\beta\alpha}^{-1})$ .

### A.3 Connections and Curvature

A *connection*  $D$  on a vector bundle  $E$  over  $M$  is a map

$$D : \Omega^0(E) \longrightarrow \Omega^1(E),$$

in other words taking sections of  $E$  to  $E$ -valued 1-forms, satisfying

$$D(f \cdot s) = f \cdot Ds + df \cdot s.$$

Given a vector field  $X$ , one can define the covariant derivative

$$D_X : \Omega^0(E) \longrightarrow \Omega^0(E)$$

in the direction  $X$  given by interior multiplication  $D_X s = X \lrcorner Ds$ .

If we choose a frame  $(e_1 \dots e_k)$  then with respect to this frame

$$Ds = ds + As$$

for a  $\mathfrak{gl}(k, \mathbb{C})$ -valued 1-form  $A$ . If  $\{x^\mu\}$  are coordinates on  $M$ ,  $A = A_\mu dx^\mu$  and  $Ds = D_\mu s dx^\mu$ , then

$$D_\mu s = \partial_\mu s + A_\mu s.$$

If a second frame  $(\tilde{e}_1 \dots \tilde{e}_k)$  frame satisfies  $\tilde{e}_\rho = e_\sigma g_\rho^\sigma$ , then with respect to the second frame  $D = d + \tilde{A}$ , where  $\tilde{A} = g^{-1}Ag + g^{-1}dg$ . If  $E$  has trivialisations such that one can reduce the structure group to a Lie group  $G$ , one can consider connections  $D$  such that with respect to these trivialisations  $A$  takes values the Lie algebra  $\mathfrak{g}$  of  $G$ . For example, when  $E$  has an Hermitian structure  $\langle \cdot, \cdot \rangle$  and one can take  $G$  to be  $U(k)$  by choosing an orthonormal frame then  $A$  is  $\mathfrak{u}(k)$ -valued if  $D$  is compatible with the Hermitian structure in the sense that

$$d\langle s, t \rangle = \langle Ds, t \rangle + \langle s, Dt \rangle.$$

One can extend  $D$  to  $p$ -forms by  $D(s \otimes \omega) = Ds \wedge \omega + s \otimes d\omega$  for  $\omega \in \Omega^p(M)$  and  $s \in \Gamma(M, E)$ . Locally  $D$  is given by  $D\omega = d\omega + A \wedge \omega$ .

Thus one can consider the *curvature*  $F$  of the connection  $D$  given by

$$F \equiv D^2 : \Omega^0(E) \longrightarrow \Omega^2(E).$$

Locally the curvature is given by  $D^2s = (dA + A \wedge A) \wedge s$ , so it does not involve derivatives and  $F \in \Omega^2(\text{End}(E))$ , i.e. an  $(\text{End}(E))$ -valued 2-form. In fact  $F$  takes values in the adjoint bundle  $\text{adj}(E)$ . For vectors  $X$  and  $Y$ ,  $F$  is given by

$$F(X, Y) = D_X D_Y s - D_Y D_X s - D_{[X, Y]} s.$$

Locally the curvature is given by  $F = \frac{1}{2} F_{\mu\nu} dx^\mu \wedge dx^\nu$ , where

$$F_{\mu\nu} = \partial_\mu A_\nu - \partial_\nu A_\mu + [A_\mu, A_\nu]$$

and with respect to a second frame  $\tilde{F} = g^{-1}Fg$ .

Given a connection  $D$  on a vector bundle  $E$  one can define a connection on the adjoint bundle  $\text{End}(E)$  which is given locally by

$$Ds = ds + [A, s].$$



In particular we can apply  $D$  to  $F$ . The connection satisfies the Bianchi identity  $DF = 0$ .

Finally, we can consider the pullback bundle  $f^*E$  of a bundle with connection  $D$ . One can define a pullback connection by  $f^*D = d + f^*A$ , where  $f^*A$  is the usual pullback of forms.

# Bibliography

- [1] L. J. Mason and N.M.J. Woodhouse, *Integrability, Self-Duality and Twistor Theory*, OUP (1996).
- [2] R. S. Ward and R. O. Wells, *Twistor Geometry and Field Theory*, CUP (1990).
- [3] C. Nash and S. Sen, *Topology and Geometry for Physicists*, Academic Press, London (1983).
- [4] C. M. Nakahara, *Geometry, Topology and Physics*, IOP (1990).
- [5] L. H. Ryder, *Quantum Field Theory*, CUP (1985).
- [6] R. J. Rajaraman, *Solitons and Instantons*, North Holland, Amsterdam (1982).
- [7] M. F. Atiyah and N. J. Hitchin, *The Geometry and Dynamics of Magnetic Monopoles*, Princeton University Press (1988).
- [8] P. M. Sutcliffe, *Int. Journal Modern Phys.* **A12**, 4663-4706 (1997).
- [9] K. K. Uhlenbeck, *Comm. Math. Phys.* **83**, 11-27 (1982).
- [10] M. F. Atiyah, N. J. Hitchin and I. M. Singer, *Proc. Royal Soc.* **A362**, 425-461 (1978).
- [11] A. Jaffe and C. Taubes, *Vortices and Monopoles*, Birkhäuser, Boston (1980).
- [12] E. B. Bogomol'nyi, *Sov. J. Nucl. Phys.* **24**, 449 (1978).
- [13] M. K. Prasad and C. M. Sommerfield, *Phys. Rev. Lett.* **35**, 760-762 (1975).
- [14] E. J. Weinberg, *Phys. Rev.* **D20**, 936-944 (1979).

- [15] R. S. Ward, *Phil. Trans. Royal Society* **A315**, 451-457 (1985).
- [16] M. J. Ablowitz and P. A. Clarkson, *Solitons, Nonlinear Evolution Equation and Inverse Scattering*, London Mathematical Society Note Series **149** (1991).
- [17] R. Penrose, *J. Math. Phys.* **8**, 345-366 (1967).
- [18] R. Penrose and W. Rindler, *Spinors and Space-time Vol. I*, CUP (1984), *Spinors and Space-time Vol. II*, CUP (1986).
- [19] R. S. Ward, *Phys. Lett.* **61A**, 81-82 (1977).
- [20] M. F. Atiyah, Magnetic monopoles in hyperbolic space, Proc. Bombay Colloquium 1984 on *Vector Bundles on Algebraic Varieties*, 1-33, OUP (1987).
- [21] N. J. Hitchin, *Comm. Math. Phys.* **83**, 579-602 (1982).
- [22] N. J. Hitchin, Complex manifolds and Einstein's equations, in *Twistor Geometry and Nonlinear systems*, Lecture notes in Mathematics **970**, 73-99 (1982).
- [23] P. E. Jones and K. P. Tod, *Classical and Quantum Gravity* **2**, 565-577 (1985).
- [24] K. Kodaira, *Ann. Math.* **84**, 146-162 (1962).
- [25] R. S. Ward, *Comm. Math. Phys.* **79**, 317-325 (1981).
- [26] M. K. Prasad and P. Rossi, *Phys. Rev. Lett.* **46**, 806-809 (1981).
- [27] P. Forgacs, Z. Horvath and L. Palla, *Phys. Lett.* **99B**, 232 (1981).
- [28] R. S. Ward, *Phys. Lett.* **102B**, 136 (1981).
- [29] E. Corrigan and P. Goddard, *Comm. Math. Phys.* **80**, 575-589 (1981).
- [30] S. K. Donaldson, *Comm. Math. Phys.* **96**, 387-407 (1984).
- [31] J. Hurtubise, *Comm. Math. Phys.* **100**, 191-196 (1985).
- [32] W. Nahm, The construction of all monopoles by the ADHM method, in *Monopoles in Quantum Field Theory*, World Scientific, 87-94 (1982).

- [33] N. J. Hitchin, *Comm. Math. Phys.* **83**, 145-190 (1983).
- [34] N. J. Hitchin, N. S. Manton and M. K. Murray, 661-692 (1995).
- [35] R. S. Ward, *J. Math. Phys.* **29**, 386-389 (1988).
- [36] R. S. Ward, *J. Math Phys.* **30**, 2246-2251 (1989).
- [37] R. S. Ward, *Comm. Math. Phys.* **128**, 319-332 (1990).
- [38] R. S. Ward, Twistors, Geometry and Integrable Systems, in *The Geometric Universe*, eds S. A. Huggett et al, OUP, (1998).
- [39] S. W. Hawking and G. R. Ellis, *The Large Scale Structure of Space-time*, CUP (1973).
- [40] R. S. Ward, *Asian J. Math.* **3**, 325-332 (1999).
- [41] V. E. Zakharov and A. B. Shabat, *Functional Analysis Appl.* **8**, 226-35 (1974).
- [42] V. E. Zakharov and A. B. Shabat, *Functional Analysis Appl.* **13**, 166-73 (1976).
- [43] Zixiang Zhou, *J. Math. Phys.* **42**, 1085-1099 (2001).
- [44] Zixiang Zhou, *J. Math. Phys.* **42**, 4938-4947 (2001).
- [45] T. Ioannidou, *Nonlinearity* **15**, 1489-1497 (2002).
- [46] T. Ioannidou, *Int. J. Mod. Phys.*, **18** 4975-4998 (2003).
- [47] T. Ioannidou, *Theor. Math. Phys* **137**, 1472-1475 (2003).
- [48] R. S. Ward, *Phys. Lett.* **208A**, 203-208 (1995).
- [49] T. Ioannidou, *PhD Thesis*, University of Durham (1996).
- [50] S. Jarvis and P. Norbury, *Bulletin of the LMS* **29**, 737-744 (1997).
- [51] C. Nash, *J. Math. Phys.* **27**, 2160-2164 (1986).
- [52] A. Chakrabati, *J. Math. Phys.* **27**, 340-347 (1984).

- [53] P. J. Braam and D. M. Austin, *Nonlinearity* **3**, 809-823 (1990).
- [54] T. Ioannidou and P. M. Sutcliffe, *J. Math. Phys.* **40**, 5440-5455 (1999).
- [55] M. Murray and M. Singer, *Nonlinearity* **9**, 973-997 (1996) .
- [56] R. Jackiw, C. Nohl and C. Rebbi, *Phys. Rev.* **D15**, 189-192 (1977).
- [57] V. Kotecha, *J. Math. Phys.* **42**, 1018-1025 (2001).

