



## Durham E-Theses

---

### *Relating onshore wind turbine reliability to offshore application*

RICHARDSON, PAUL

#### How to cite:

---

RICHARDSON, PAUL (2010) *Relating onshore wind turbine reliability to offshore application*, Durham theses, Durham University. Available at Durham E-Theses Online: <http://etheses.dur.ac.uk/1408/>

#### Use policy

---

The full-text may be used and/or reproduced, and given to third parties in any format or medium, without prior permission or charge, for personal research or study, educational, or not-for-profit purposes provided that:

- a full bibliographic reference is made to the original source
- a [link](#) is made to the metadata record in Durham E-Theses
- the full-text is not changed in any way

The full-text must not be sold in any format or medium without the formal permission of the copyright holders.

Please consult the [full Durham E-Theses policy](#) for further details.

**Paul Richardson**  
**Relating onshore wind turbine reliability to offshore application**

**Abstract**

With the award of the latest Round 3 offshore wind farm sites around the UK coast the wind industry is moving from the operation of near inshore to truly offshore wind farms. This has two major implications, the first being that wind turbines are now being specifically designed for offshore deployment, a key feature being that the new wind turbines are likely to be two to four times the size of the largest current onshore machines. The second is that due to the limitations of access to offshore wind turbines, their availability needs to be in the order of 98% or greater if reasonable costs of energy are to be achieved. The distance of the wind turbines from shore means that more attention needs to be given to the availability, reliability and maintainability of these offshore wind turbines.

The research discussed in this report set out to examine these factors in more depth, using the reliability data of Clipper Windpower's onshore 2.5 MW Liberty machine as the practical evidence for doing so. In analysing the data the primary aim was to build a picture of typical fault type and duration and more specifically alarm type, distribution and alarm quantity. These results were then compared with an external data source to identify common trends or major divergences and the findings used to identify potential improvements in availability, reliability and maintainability for the design of Clipper Windpower's offshore Britannia 10 MW machine.

The key conclusions of the research are that:

- \* The Britannia wind turbine pitch system needs dramatic improvement on that of the Liberty wind turbine and this requires further detailed investigation.
- \* The ability to access the wind farms quickly and cost effectively will be critical to maintaining the required levels of wind turbine availability.
- \* The Britannia wind turbine needs to be designed for reliability and availability not simply for keeping the wind turbine in a safe mode.
- \* The number and classification of alarms built into the wind turbine monitoring system needs to be critically reviewed with the aim of reducing and rationalising responses where possible.



Durham  
University

School of Engineering  
and Computing Sciences

# Relating Onshore Wind Turbine Reliability to Offshore Application.

Paul Richardson  
**2010**

*Project for the Degree of  
Master of Science (by research)*

New & Renewable Energy Group  
School of Engineering & Computing Sciences  
Durham University  
United Kingdom



This Project Received Funding From One North East

**Copyright © 2010 Paul Richardson and Professor Peter J. Tavner**  
The copyright of this report rests with the author and Professor Peter J. Tavner.  
No quotations from it should be published without the author and Professor Tavner's  
prior written consent and information derived from it should be acknowledged

## Table of Contents

<b>Abbreviations</b>	1
<b>Declaration</b>	2
<b>Acknowledgements</b>	3
<b>1. Introduction</b>	4
<b>2. Literature Review</b>	7
2.1 Reliability	11
2.2 Availability	17
2.3 Maintainability	17
2.4 Serviceability and Repair	18
2.5 Site Accessibility	18
2.6 Operations and Maintenance	21
2.7 Summary	24
<b>3. Taxonomy of the Wind Turbine</b>	25
3.1 IEC 61400 Standards	25
3.2 Reference Designation System for Power Plants Standard	26
3.3 Germanischer Lloyd	27
3.4 Clipper Taxonomy	28
3.5 Summary	29
<b>4. Structure of Wind Turbine Data</b>	30
4.1 Alarm Number and Type	33
4.2 Reducing Total Number of Alarms	35
4.3 Aggregate Alarms	36
4.4 Reduce Alarm Severity	37
4.5 Automated Reset	39
4.6 Summary	39
<b>5. Performance Data Analysis</b>	<b>40</b>
5.1 Cube Data Analysis	41
5.2 ReliaWind v Clipperwind Failure rate Comparison	41
5.3 ReliaWind v Clipperwind Down Time Comparison	43
5.4 Summary	50
<b>6. Site Accessibility Options</b>	<b>51</b>
6.1 Helicopters	52
6.2 Vessels without Access Systems	55
6.3 Vessels with Access Systems	57
6.4 Mobile Fixed Installation Jack-up	65
6.5 Fixed Installations	66
6.6 Potential Option for the Future	67
6.7 Weather Prediction	68
6.8 Onshore v Offshore Costs	69
6.9 Summary	70
<b>7. Discussion</b>	<b>71</b>
7.1 Design	71
7.2 Operational Strategy	74

7.3 Maintenance Strategy	76
<b>8. Conclusions and Further Work</b>	<b>83</b>
8.1 Conclusions	84
8.2 Future Research	85
<b>Appendix A: Liberty v Britannia Specifications</b>	<b>87</b>
<b>Appendix B: Structure for the research developed by the author</b>	<b>89</b>
<b>Clipper Windpower Internal References</b>	<b>90</b>
<b>External References</b>	<b>90</b>

## Figures

Figure 1.	The geographic location for Round 1 & 2 sites giving some idea of the distance from shore and scale of the sites involved	8
Figure 2.	The geographic location for Round 3 sites giving some idea of the distance from shore and scale of the sites.	10
Figure 3.	Availability as a function of machine properties site accessibility and maintenance strategy.	11
Figure 4.	WT sub-assembly failure rate and downtime per failure for two surveys including respectively 15400 and 5800 of onshore WT years of data.	12
Figure 5.	Onshore –Offshore WT market overlap and bifurcation.	14
Figure 6.	Multi Level control system in an integrated design approach.	16
Figure 7.	Site conditions v accessibility and gross energy yield v availability for Offshore Wind Energy Converter Systems (OWECS).	19
Figure 8.	Example of weather making WT inaccessible with a 1.5/2.5m wave height.	20
Figure 9.	Schematic overview of different maintenance types.	22
Figure 10.	Freeze Frame from a wind farm animation	24
Figure 11.	TCU Control Logic- part 1	31
Figure 12.	TCU Control Logic - part 2	32
Figure 13.	Proportion of alarms by Sub-system - % Annual Alarms & Lost Time Hours v Alarms as % of total on WTG	34
Figure 14.	Temporary Remote Reset rules for Battery Warning flow diagram.	38
Figure 15.	Overall fault rate for Clipper’s Liberty Wind Turbine	43
Figure 16.	Normalised Fault rate of sub-systems and assemblies for WT’s of multiple manufacturers in the ReliaWind database.	44
Figure 17.	Normalised hours lost per WT per year to faults in sub-systems for Clipper’s Liberty WT.	46
Figure 18.	Normalised hours lost per WT per year to faults in sub-systems for Clipper’s Liberty WT.	47

Figure 19.	Breakdown of Fault Alarm Count and Fault Hours for the Pitch System.	49
Figure 20.	The three Battery Boxes installed in the Liberty Hub.	50
Figure 21.	Examples of offshore access to Vestas V80 WTs at Horns Rev by helicopter.	53
Figure 22.	Examples of access by transfer boats.	55
Figure 23.	Example of a field support vessel (FSV).	57
Figure 24.	Ampelmann Offshore Access System.	59
Figure 25.	Vessel size influences the Ampelmann window of operation.	60
Figure 26.	Offshore Access System (OAS).	61
Figure 27.	Personnel Transfer System (PTS).	62
Figure 28.	SLILAD: Passive System WT-mounted.	64
Figure 29.	MOMAC Offshore Transfer System (MOTS).	64
Figure 30.	Example of a Mobile Fixed or Jack-up installation as used during the construction of Horns Rev and Kentish Flats wind farms.	65
Figure 31.	Example of a Fixed Substation Installation at Horns Rev Wind Farm.	67
Figure 32.	ABS+A1 Mobile Offshore Unit DP3 – Concept vessel.	67
Figure 33.	Ultracapacitor EPU sub module for a 1MW rated WT.	72
Figure 34.	A forward looking laser used to proactively measure wind speed.	73
Figure 35.	Movement of Information around a Wind Farm.	75
Figure 36.	Example format of an Electronic Maintenance & Repair report.	77
Figure 37.	Schematic of Routine v Arbitrary v Optimised Maintenance Systems.	78
Figure 38.	“Finger Prints” of blade pair for WT1087.	80
Figure 39.	“Finger Prints” of blade pair for WT1082.	81
Figure 40.	“Finger Prints” of blade pair for WT1114.	82
Figure A2	Comparative Size of Nacelles for the Liberty WT and the Britannia WT (to scale).	87
Figure A3	Comparative Size of the Two WTs Compared with well known Geographical Features.	87
Figure B1	Structure for the research developed by the author	88

## **Tables**

Table 1.	Overview of the Round 3 Sites Awarded.	9
Table 2.	Varying Taxonomy (Collated by Author).	25
Table 3.	Summary of Germanischer Lloyd CMS measurement requirements.	28
Table 4.	Restart rules for PCU Alarms 929/930/931.	38
Table 5.	Round 1 and 2 Wind Farm Distances from Shore.	51
Table 6.	Distance from major UK East coast ports to the two largest new Sites.	52
Table 7.	Calculation of hourly maintenance cost using helicopters.	53
Table 8.	Comparison of various sized helicopters.	54
Table 9.	Calculation of hourly maintenance cost using transfer boats.	56
Table 10.	Calculation of Estimated hourly maintenance of an FSV.	58
Table 11.	Calculation of Estimated hourly maintenance for onshore WT.	69
Table 12.	Comparison of hourly maintenance costs based on transportation cost	69
Table A1	Proposed Britannia WT Specification Compared with Liberty WT Specifications.	88

## **Equations**

Equation 1.	Definition of availability.	17
-------------	-----------------------------	----

## Abbreviations

A	Availability of the Wind Turbine to generate electricity
CBM	Condition Based Maintenance.
CMS	Condition Monitoring Systems.
DIN	Deutsches Institute Für Normung
DP	Dynamic Positioning.
EPU	Emergency Power Unit.
EU	European Union.
EWEA	European Wind Energy Association.
FMEA	Failure Modes and Effect Analysis
FSV	Field Supply Vessel.
GCU	Generator Control Unit.
GW	Gigawatt.
H <sub>m</sub>	Maximum Wave Height
H <sub>s</sub>	Significant Wave Height
IEC	International Electrotechnical Commission.
I/O	Input/Output (Of data)
ISO/TS	International Standards Organisation / Technical Standard
Kg	Kilogramms
Km	Kilometres
LDT	Logistic Down Time
KKS	Kraftwerk Kennzeichen System
KWh	KiloWatt Hour
LWK	Landwirtschaftkammer
MOB	Man Overboard Boat.
MTBF	Mean Time Between Failures.
MTTF	Mean Time To Failure.
MTTR	Mean Time To Repair.
MW	Megawatt.
NAREG	New And Renewables Energy Group
OAS	Offshore Access System.
O&M	Operations and Maintenance.
OWEC(S)	Offshore Wind Energy Converter (Systems).
PCU	Pitch Control Unit
PTS	Personnel Transfer System.
QA/QC	Quality Assurance / Quality Control.
RDS-PP	Reference Designation System for Power Plants.
SCADA	Supervisory Control And Data Acquisition.
SEA	Strategic Environmental Assessment
SLB	Sealed Lead Acid Battery.
SOC	State Of Charge.
SOH	State Of Health.
T	Time
TCE	The Crown Estates.
TCU	Turbine Control Unit.
TWh	Terawatt hours.
VDAS	Versatile Data Acquisition System.
VTT	Valtion Teknillinen Tutkimuskesus
WMEP	Wissenschaftliches Mess und EvaluieringsProgramm
WT	Wind Turbine.



## **Declaration**

The work described in this report is based on research carried out under the supervision of Professor Peter J. Tavner in the New and Renewable Energy Group (NAREG) of the School of Engineering and Computing Sciences of Durham University. The research was funded by a One North East Studentship grant.

## **Acknowledgements**

The Author would like to thank the following individuals for their support.

Clipper Windpower Marine Limited and in particular their engineering manager Dr Bill Grainger for providing the industrial mentoring element of the project. Also for allowing me access to the company's databases, use of their office facilities and general support.

Professor Tavner and Dr Dominy for supervising my work, providing support, guidance and encouragement throughout the year. Fellow research students in the NAREG department at the University for their comradeship, support and help throughout the year.

My brother in-law, Professor Toni Slabas, for alerting me to the sponsorship opportunity. My sister Dr Pat Richardson and Toni for providing accommodation when staying in Durham and for the encouragement they both provided throughout the year.

Last but not least One North East for providing financial support for the project.

## 1. Introduction

Europe is faced with the global challenges of climate change, depleting indigenous energy resources, increasing fuel costs and the threat of energy supply disruptions. Over the next 12 years, according to the European Commission (EU), 360 GW of new electricity capacity, that is 50% of current capacity, needs to be built to replace ageing power plants and meet the expected increase in demand [1]. Europe is using the opportunity created by this large turnover in capacity to construct a new, modern power system with significant renewable energy generation capacity to meet the energy and climate change challenges of the 21st century, while enhancing Europe's competitiveness and energy independence.

The new EU 'climate-energy legislative package' has set an ambitious mandatory national target corresponding to a 20% share for renewable energies in overall Community energy consumption by 2020 [1]. As a proven source of clean, affordable energy, wind resources have a vital role to play in helping to realise this goal. In response the wind power sector has grown enormously in the EU in recent years. At the end of 2008, there were 65 gigawatts (GW) of wind power capacity installed in the EU- 27 countries producing 142 terawatt hours (TWh) of electricity, meeting 4.2 % of EU electricity demand. By comparison the total electrical energy production for the UK in 2008 was approximately 360 TWh.

In 2009, the European Wind Energy Association (EWEA) increased its 2020 target for installed wind power capacity to 230GW, including 40 GW offshore wind. To reach 40 GW of offshore wind power capacity in the EU by 2020 is a challenging task. It would require an average growth of 28% in annual wind turbine (WT) installations i.e. an increase from 366MW in 2008 to 6,900MW in 2020. In the 12 year period from 1992-2004, the market for onshore wind capacity in the EU grew by an average 32% annually: from 215MW to 5,749MW. There is nothing to suggest that this historic rate of onshore wind development could not be repeated offshore but it will require a high degree of industrialisation in the manufacture, logistics and deployment of offshore WT to achieve it [2]. An entire new offshore wind power industry and a new supply chain must be developed on a scale that will match that of the North Sea oil and gas endeavour of the 1960s and 1970s.

An important factor in the growth of offshore wind is the ability to operate and maintain offshore WTs cost-effectively. However, operations & maintenance (O&M) of offshore wind farms will be more difficult and therefore more costly than equivalent activities in onshore wind farms. Collecting and interpreting data efficiently and automatically from remote offshore wind farms will become more critical because of this factor alone. Accessibility for routine servicing and maintenance is a major concern. During harsh winter weather, a complete wind farm may be inaccessible for a number of days due to sea, wind and visibility conditions. Even given favourable weather conditions, offshore O&M tasks will be more expensive than onshore, being influenced by the distance of the WTs from shore and harbour, the exposure of the site, the size and reliability of the WTs, the maintenance strategy under which they are operated and health & safety considerations. Offshore installations require the use of specialised lifting equipment to both install and change out major components and this must be scheduled well in advance [3]. The severe weather conditions experienced by an offshore wind farm dictate the requirement for high reliability components coupled with adequate environmental protection for virtually all components exposed to sea conditions.

In the early days of offshore wind farms onshore WTs, that had been adapted for the marine environment, were placed offshore with disastrous results. For example at Horns Rev site off Jutland in Denmark 80 Vestas V80 WT nacelles had to be taken back onshore, refurbished and upgraded after only two years of low reliability operation. The next generation of offshore WTs will need to be specifically designed for offshore use, rather than using onshore WTs that have been poorly adapted for the marine environment.

It was in this policy context and operational environment that the research presented in this document was undertaken. The aim of the research was to examine in more depth the availability, reliability and maintainability of Clipper Windpower's onshore Liberty 2.5 MW WT. The primary objective was to build a picture of typical fault types and durations, to extrapolate that to offshore conditions and to help focus design effort on a new Clipper Windpower offshore 10 MW WT which is to be known as the Britannia. Specifications of the two turbines are given in Appendix A1. An indication of the relative size of the two nacelles and the scale of the two turbines compared to the Statue of Liberty in New York and the "Gherkin" building in London is presented in Appendix A2 and A3 respectively.

The approach taken by the research is detailed in Appendix B.

In chapter 2 a review of the literature surrounding the wind power industry and WT performance in particular is presented. This examines the scale of current problems, assesses current know how and investigates the future direction of the industry. Chapter 3 examines and compares the various methods of labelling the structural components or taxonomy of a WT. It also shows how the different systems used for describing a WT make the comparison of direct reliability data very difficult. In Chapter 4 the existing structure of the Liberty WT is defined and the alarm architecture is examined using the company's internal specification documentation for the WT [A], fault logic, control logic [B] and data collection description [C]. This chapter also describes proposed improvements to the alarm structure. Chapter 5 discusses the core primary data analysis. The live Supervisory Control and Data Acquisition (SCADA) database from Clipper Windpower, known as the 'CUBE', was interrogated for one year to establish actual fault and lost time data by sub-assembly. This dataset was then compared against the results of an independent external study. Chapter 6 addresses the issue of accessibility, which is of critical importance when moving far offshore. and Chapter 7 discusses the findings with proposed solutions 7. Finally Chapter 8 summarises conclusions from research and outlines proposed further work.

## **2. Literature Review**

The literature review was conducted with three primary aims. Firstly to assess the scale of the problems currently faced by the industry and those projected for the future with the move to large offshore wind farms. Secondly to identify current 'know-how' and experience in preventing and tackling these problems. Thirdly to investigate the future direction of industry developments that may give solutions to projected or predicted /possible problems in the future.

In December 2000 The Crown Estate announced the first round of UK offshore wind farm development. This Round 1, as it was known, was intended to act as a 'demonstration' providing prospective developers with an environment in which they could gain technological, economic and environmental experience. Round 1 was intended to cater for projects of up to 30 turbines. The selection of sites was largely driven by the developers. Eighteen sites were awarded, with a combined capacity of up to 1.5 GW [4].

In 2002 a government report 'Future Offshore' set out the framework for offshore wind development in the UK. This report identified three strategic areas for development and a strategic environmental assessment (SEA) was carried out for each of the following areas, the Greater Wash, the Thames Estuary and Liverpool Bay in the northwest. The Round 2 tender process was for commercial scale projects within these three areas, with the aim of meeting the offshore wind capacities identified by the SEA. The fifteen successful commercial scale projects awarded Crown Estate agreements for lease amounted to 7.2 GW and included sites beyond territorial waters [4].

Whilst the official map provided by The Crown Estate in Figure 1 is of low resolution it does illustrate the scale and distance from shore of the Round 1 & 2 wind farm sites.

With the award of the latest offshore wind farm sites, in Round 3, the United Kingdom (UK) wind industry is moving from near inshore to true offshore wind farms. The furthest proposed outer edge from land for offshore wind farms is 195km and the closest 13km, compared with a previous maximum of around 12km for existing offshore wind farms [5]. The distance from shore means that more

focus is needed on the availability, reliability and maintainability of the offshore WT.

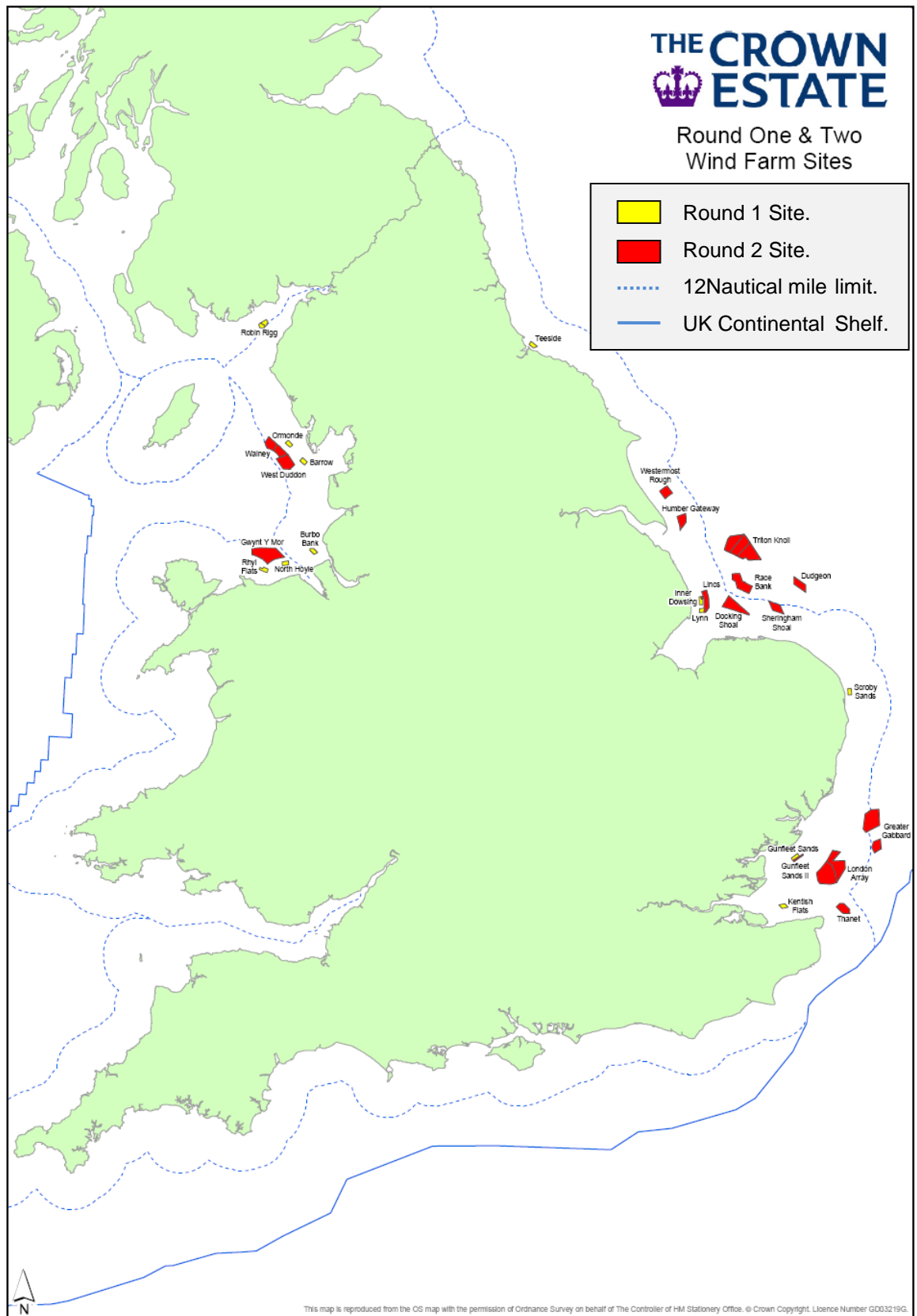

Figure 1: The geographic location for Round 1 & 2 giving some idea of the distance from shore and scale of the sites [4].

Historically offshore WTs have had availability levels of 60-90%, due to the lost time associated with failures and access limitations [6]. Offshore WT availability will need to be in the order of 98% or greater if reasonable costs of energy are to be achieved [7,8]. The main details of each of the nine offshore wind farm sites awarded by The Crown Estates in Round 3 are summarised in Table 1 below and their locations are shown in Figure 2.

Assuming an onshore WT availability of 97% it has been demonstrated that offshore availability could become some 76% for a location 15 km offshore assuming a moderate 25% inaccessibility factor due to high winds and/or waves [6]. It can be seen from Table 1 that only three sites out of the 9 UK Round 3 sites match to this. The other 6 sites are two to eight times further offshore, where improving WT availability will be even more critical.

**Table 1: Overview of the Round 3 Sites Awarded [5]**

Zone	Name	Possible Power (GW)	Min Distance to Zone (km)	Max Distance to Zone (km)	Zone Area (km <sup>2</sup> )	Min Water Depth (m)	Max Water Depth (m)
1	Moray Firth	1.3	28*	-	520	30	57
2	Firth of Forth	3.5	53.8	80	2852	30	80
3	Dogger Bank	9	125	195	8660	18.6	63.5
4	Hornsea	4	19	34	4735	30	70
5	Norfolk Bank	7.2	55.5*	-	6037	5	70.1
6	Hastings	0.6	13	26	270.2	19	62
7	W. of Isle of Wight	0.9	20.7*	-	723.7	27.8	56.3
8	Bristol Channel	1.5	24.4*	-	949.7	19.5	60.9
9	Irish Sea	4.2	15	40	2200	28	78

\* NB: Distance given is to the centre of the zone.

Source: Compiled by the author from data given at The Crown Estates website <http://www.thecrownestate.co.uk/round3>



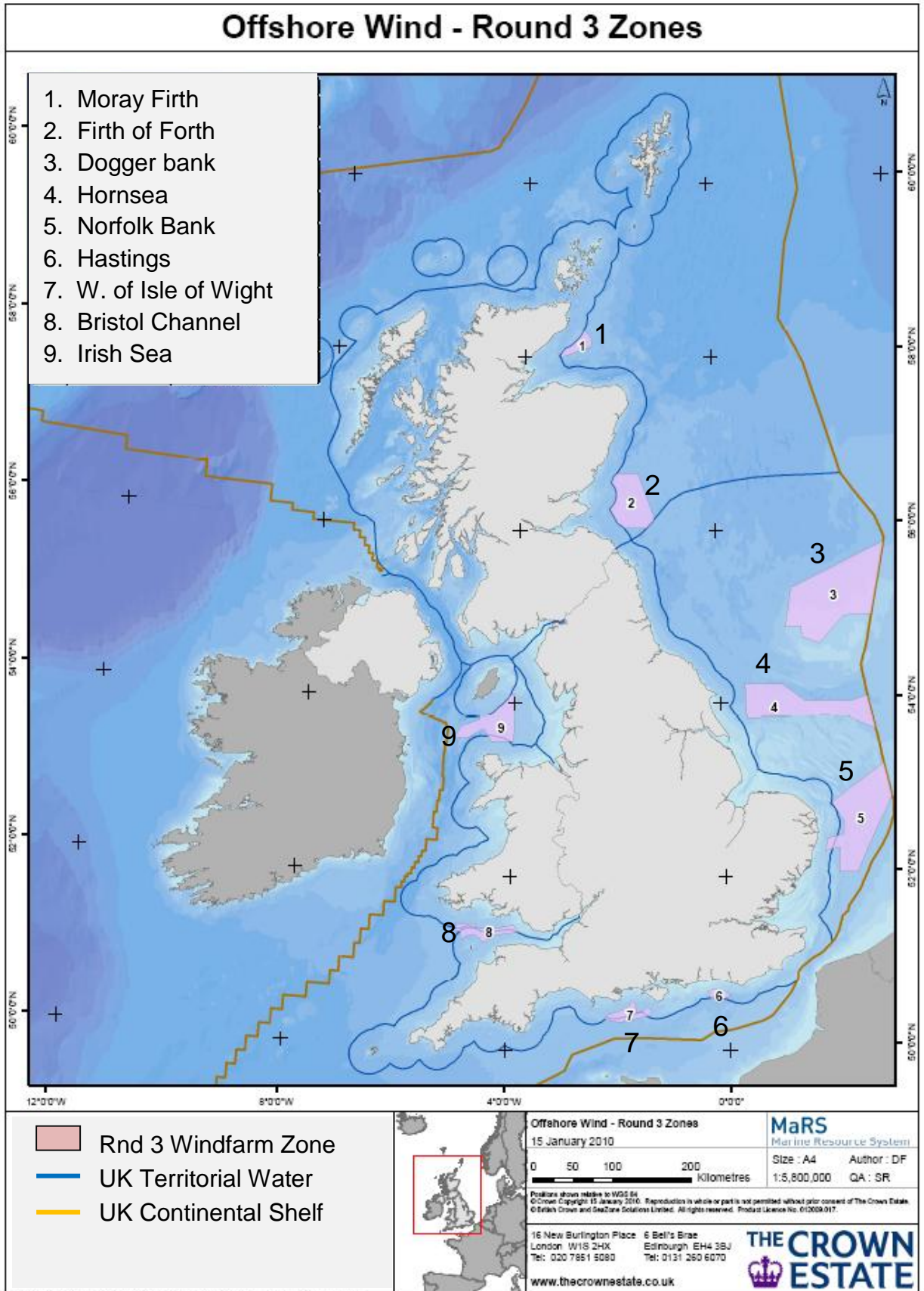
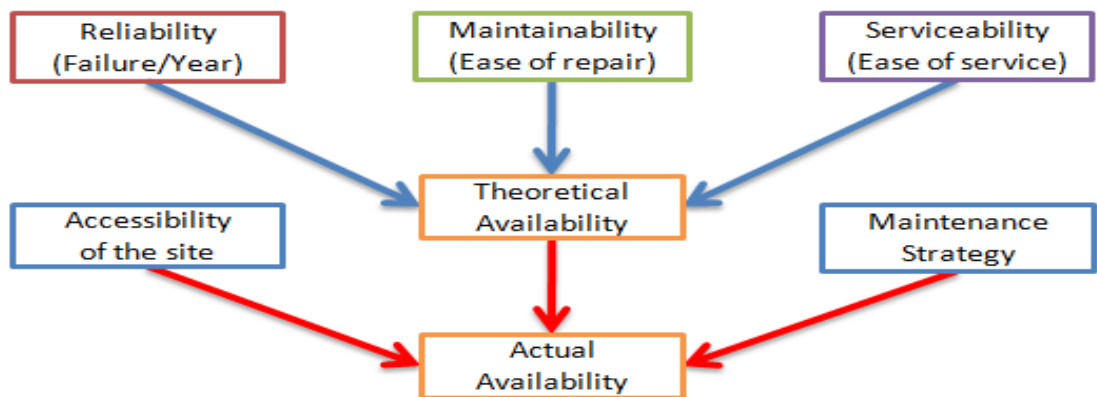

Figure 2: The geographic location for Round 3 sites giving some idea of the distance from shore and scale of the sites [5].

In looking at the availability of any WT there are a number of factors or issues that need to be considered and these factors affect the theoretical availability and more importantly the actual availability of WTs. Figure 3 below illustrates the main factors or “building blocks” identified by the author for this research.

**Figure 3: Availability as a function of machine properties site accessibility and maintenance strategy [3]**



The research examines each of these “building blocks” in some detail and the factors surrounding each are discussed below.

## 2.1 Reliability

Improving the reliability of offshore WTs is paramount to the success of offshore wind energy in the future. The larger the machine and further away from the coast, the larger the economic loss for non-operation and associated maintenance.

Reliability or failures of a system per year is the probability that the system will perform its tasks. This probability is usually determined as a percentage of time. For a WT this indicates the percentage of time it is producing the power that corresponds to the acting wind according to its nominal power curve [6]. Reliability analysis is of necessity a backward looking process and rarely produces data for the wider industry which is less than 5 years old. However, the advantage of reliability data is that it is numerical and comparable. WT failure rates and downtimes (Figure 4) can be used as a datum against which future designs could be measured. For example, while an average reliability of 1 failure per WT per year could be acceptable onshore, it is unlikely to be acceptable offshore where access may be limited to only one visit a year [9]. During this research it has been found that mean time between failures onshore are measured in weeks, whilst mean time to repair is measured in hours. Offshore this would need to be months

between failures as mean time to repair would be in the order of days as discussed later.

**Figure 4: WT sub-assembly failure rate and downtime per failure for two surveys including respectively 15400 and 5800 of onshore WT years of data [11].**

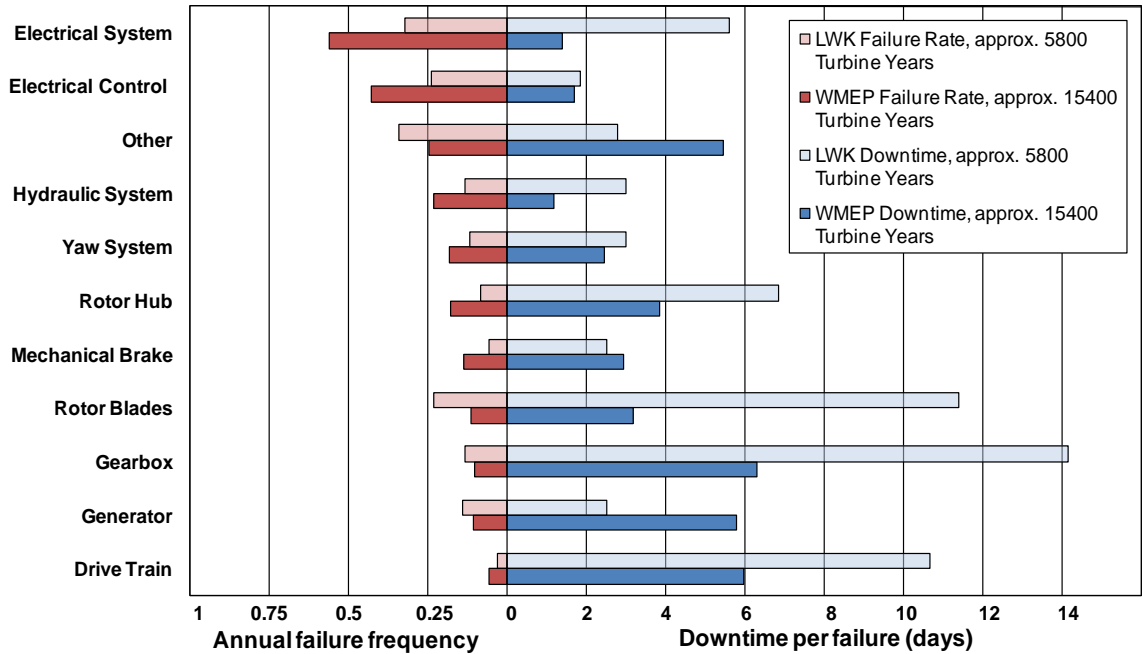

Experience has shown that the profitability of wind farms is increasingly affected by poor system reliability and hence high maintenance costs. The effect of low reliability on WT downtime has been seen most acutely during the move to offshore wind farms, such as at Horns Rev, the first large offshore wind farm off Jutland in Denmark. It is widely believed that many of the recent problems at Horns Rev were due to design issues resulting from the rapid up-scaling of onshore WT ratings, as well as an inadequate understanding of the commissioning needed for the WT and the complex and potentially aggressive loads to which offshore WTs are subjected [10]. In order to establish large WT production volumes, several pressing demands have to be met. This could be realised through a continuous, incremental improvement strategy based on current WT system concepts.

Alongside this incremental improvement strategy, offshore project designers and operators are requesting the development of completely new concepts. This approach is also an opportunity to make significant reductions in the cost of energy by developing innovative concepts. As Gray et Al discussed in their research these two strategies are usually best developed in parallel [10].

One example of a simple approach to improved reliability, taken by Enercon, has been to remove the gearbox and use a direct drive WT configuration, hence reducing the number of moving parts. Enercon has also adopted an all-electric approach, avoiding for pitch or yaw control the use of hydraulics with their associated hydraulic fluid cleanliness, pump failure and fluid leakage problems [9]. Although these improvements were for an onshore WT such improvements could be even more applicable to offshore WTs.

Figure 5 illustrates the move towards offshore-specific WT designs and the trend for the ever increasing size of WTs for offshore use. In summary:

- It shows the top 10 global suppliers, by market share, only for the onshore wind supply market with the addition of Repower, a major investor in offshore WT design.
- The circles represent product offerings where the size of the circle corresponds to the power rating of the WT.
- The green circles show the onshore WTs; the light blue circles are transition models of WTs that have been used both onshore and offshore; the dark blue are WTs designed for offshore use that are currently in use or are under production and the lilac circles to the right are proposed offshore WTs currently under design.
- The bracketed percentages represent their respective global market share in 2008.

This diagram clearly illustrates that proposed WTs are becoming larger as wind farms move offshore with the intention to move far offshore. The aim being to reduce the cost of foundations and maximise energy production with reduced turbine numbers or maintain the same number of turbines per unit of ground achieving more energy per unit.

Figure 5: Onshore –Offshore WT market overlap and bifurcation [12].

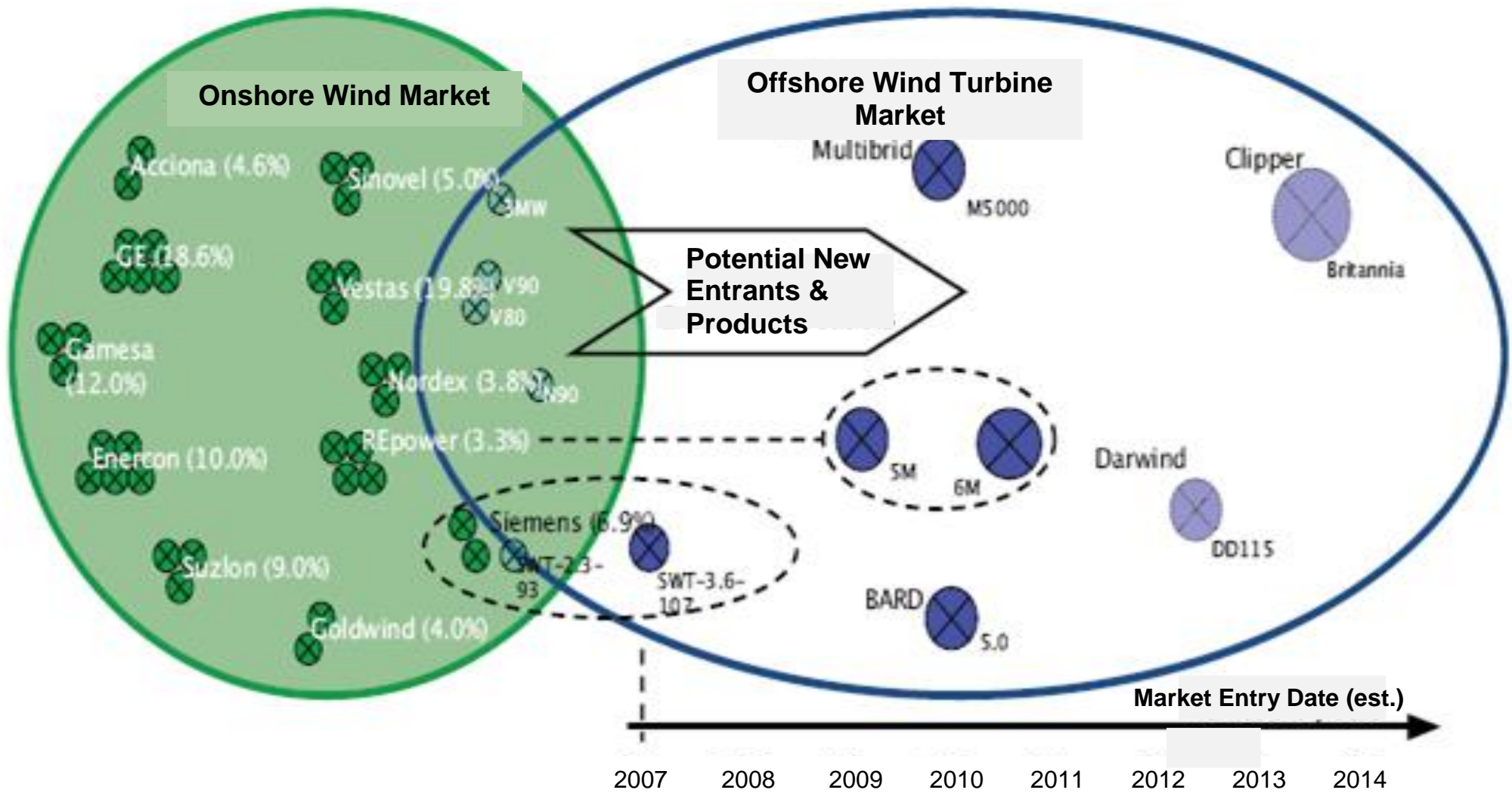

Current WTs, greater than or equal to 2 MW, are much larger and weight and efficiency optimised than earlier smaller models less than or equal to 1 MW. They need a number of major overhauls during their lifetime to ensure efficient operation, as does any conventional power generation plant. WTs are currently designed in such a way that the change of main assemblies or sub-assemblies, such as the blades gearbox or generator, is time-consuming and costly. More efficient and newer 'drive train'<sup>1</sup> concepts are needed to address these issues and bring WT reliability and availability up to required levels. A more modular drive train build-up with more inbuilt redundancy could promote faster, cheaper and more efficient WT maintenance. Innovative concepts, including direct-drive, variable speed offshore WTs are currently emerging, incorporating some of these aims and limiting the number of moving parts. The target must always be to increase the mean time between failures (MTBF) through developing more reliable systems and improving the strength and quality of materials used. The significant increase in expense of producing WTs using more advanced and highest quality materials will limit the cost-effectiveness of such improvements [13]. This is offset by the increasing economies of scale producing larger rated WTs.

Figure 6 shows the key factors that governing WT operations in the broadest sense. The left hand column shows the interrelationship between the WT design, at the assembly and sub-assembly levels, and the various system aspirations and goals that drive the overall process.

---

<sup>1</sup> The components of a WT (shafts and gearing) that connect the driving blades and hub to the generator.

Figure 6: Multi Level control system in an integrated design approach [14].

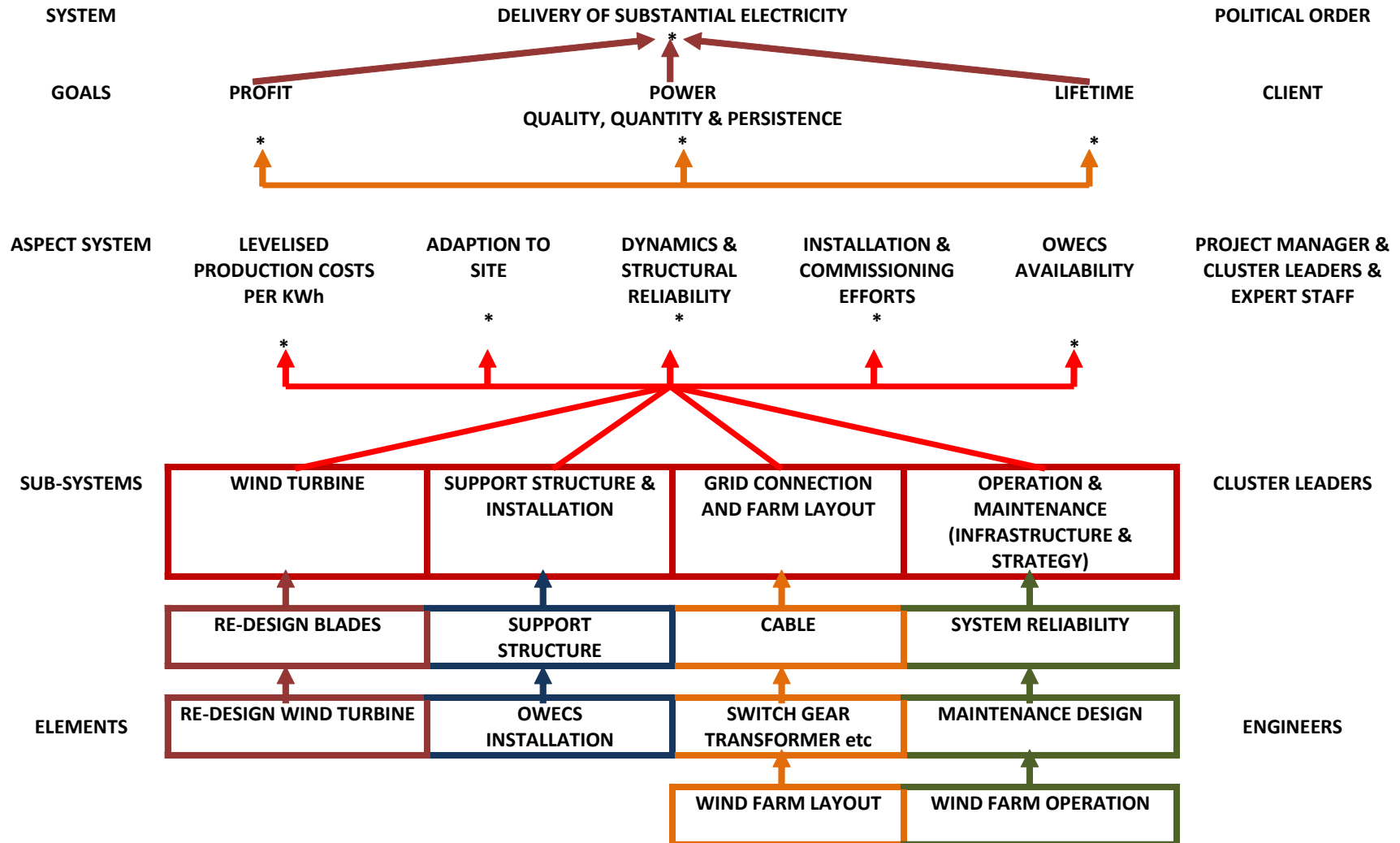

## 2.2 Availability

Availability is defined as the probability that a WT is operating satisfactorily. The major difference between reliability and availability is the operations and maintenance (O&M) strategy of the WT, which controls the downtime that WTs experience as a result of a failure. A WT can be very reliable, i.e. its failure frequency can be extremely low, but when no maintenance or repair action is taken after a failure its availability still becomes poor [6]. Availability is a fundamental outcome of reliability. It combines both the outage time when a failure has occurred and the frequency of failures. The concept of a component's availability has several different definitions. A commonly used definition of the probability that the component or system is capable of functioning at a time  $T$ . The availability  $A$  is thus defined as:

$$A = \frac{MTTF}{MTTF + MTTR}$$

Equation 1 - Definition of availability

where  $MTTF$  is mean time to failure,  $MTTR$  is mean time to repair.  $MTBF$  is mean time between failures [15].  $MTBF=MTTF+MTTR$ .

## 2.3 Maintainability

Maintainability or ease of repair is a more qualitative factor and addresses the ease of repair. It is normally expressed and quantified in terms of hours needed to complete a repair action [6]. This is referred to as the mean time to repair or  $MTTR$ . A 'no maintenance' strategy for offshore wind farms is not an option. A combination of reduced failure rates (25-45%) and improved maintenance regime will be necessary to re-establish onshore availability levels (96-98 %) for an offshore site with modest storm levels (18 %) [16].

The overall aim for any offshore wind farm reliability design will be to reduce the  $MTTR$  through various initiatives such as:

- Better and specific targeted training of maintenance engineers.
- More efficient and improved specialist maintenance equipment.
- Increased condition monitoring and advanced planning of maintenance schedules.



- Reducing as far as possible the logistic down time (LDT = Waiting on parts/personnel/equipment). LDT can be reduced by the establishment of an on-site, or near-site, storage of spare parts.
- More built-in redundancy to reduce the requirement for WT maintenance interventions [13].

A typical offshore wind farm of 100 WTs will need a permanent crane facility to take advantage of weather windows to achieve desired MTTRs. A modified self-propelled jack-up platform equipped with a crane could be part of the investment in such a large-scale wind farm [16].

#### **2.4 Serviceability and Repair**

Serviceability is the ease of regular or scheduled service [6], and many maintainability criteria discussed above are applicable to serviceability. In addition to these common criteria a more modular attitude to the build-up of WT components could improve serviceability. The inclusion of built-in nacelle cranes that can be used to lower components to the foundation level, negate the need for large external lift barges for routine servicing of components, which is proving advantageous. These cranes also mean that modular replacement components, repaired/refurbished onshore, can be rapidly swapped-out with failed component, saving time on site because fault-finding and repair can be done onshore [13]. Preventive and automatic systems that can carry out oil, brush and filter changes without human intervention would greatly improve serviceability. Also multi-coated blades that keep blade servicing to a minimum is a new technology that is helping to increase serviceability [2]. Other new technologies that could further improve serviceability are discussed in Chapter 7.

#### **2.5 Site Accessibility**

Site accessibility is the percentage of time that an offshore site can be accessed. Accessibility is highly dependent upon the method and equipment used to gain access to the site [6]. Figure 7 shows the qualitative relationship between site conditions, accessibility and gross energy yield, on the one hand and availability, with respective energy costs for different levels of design reliability, on the other hand.

As early as 1997 the question of offshore wind farm site accessibility was raised. Not only is installation more difficult and more costly but offshore WT maintenance accessibility also has a major cost impact. It may well be that a complete wind farm is inaccessible by boat or helicopter for periods of one or two months because of harsh weather conditions, such as wind, waves, fog, snow and ice.

**Figure 7: Site conditions v accessibility and gross energy yield v availability for Offshore Wind Energy Converter Systems (OWECS) [14]**

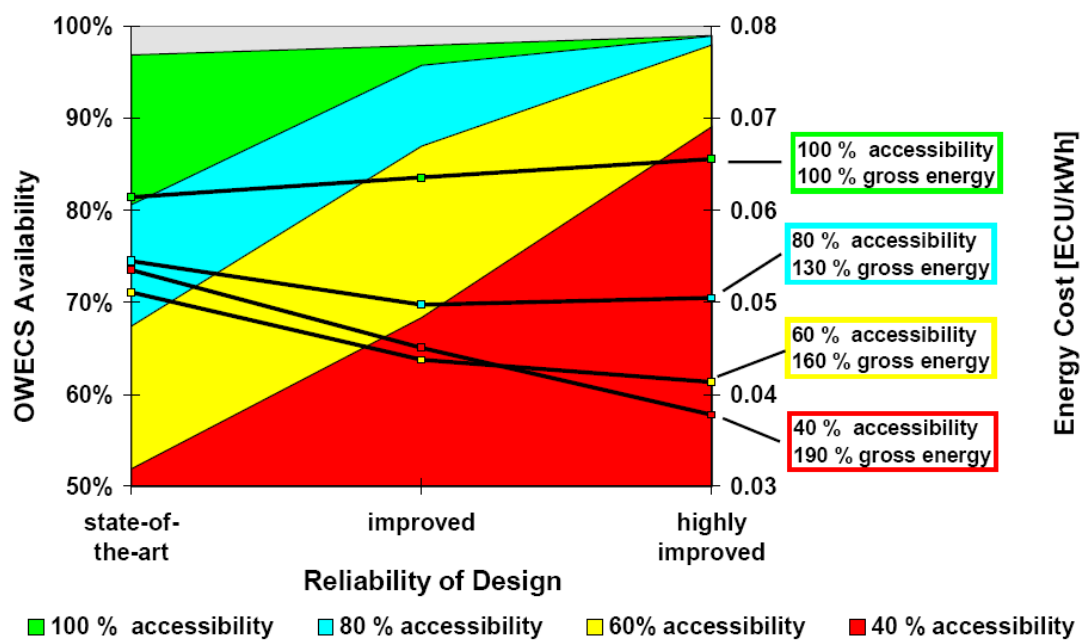

Even when the weather permits access to the WTs, the cost of offshore maintenance is far higher than the equivalent job onshore because of the additional access costs associated with boat or helicopter hire, and the time taken to physically get to a site.. Lifting actions are performed relatively easily on land, but in an offshore environment they are specialised, and therefore costly using sometimes scarce equipment. The question of accessibility is discussed in more detail in chapter 6.

The advantages and disadvantages of the three main means of accessing offshore sites are outlined below

### Helicopters

The helicopter has been suggested as a means of transport to and from offshore WTs, indeed the 80 MW Horns Rev WTs were equipped for helicopter access. However, the use of helicopters has turned out to be unfavourable. It requires the provision of a helicopter landing platform on each WT, which are expensive to construct and maintain even for large WTs. Helicopters are limited in the number

of personnel that can be transported and delivered to the WT. The cost of maintenance operations using helicopters is very high [16] and could be prohibitive. The amount of equipment/spares that can be carried offshore in a helicopter and lowered to the WT also severely limits the work that can be carried out limiting it in most cases to the most basic rudimentary servicing and maintenance. However it will be shown in Chapter 6 that small helicopters can be effective for minor interventions with far offshore sites on a cost basis.

### Small Vessels

Experience has shown that accessing individual WTs by vessel instead of a helicopter is frequently more economical [16]. Typically inshore/near-shore sites have an average accessibility by vessel of around 85% of time. These vessels would normally be rubber dirigible, rib or small catamaran vessels. These vessels rely upon some of the following WT foundation features to make them feasible:

- Platforms fixed to the WT tower above the splash-zone with fender posts to absorb vessel impact.
- Flexible gangways extended from the vessel and held in the lee of the WT base.
- Installation of friction posts on the WT base against which the vessel maintains a forward thrust during transfer [3].

The size of the vessel and mode of personnel transfer means that they cannot be used in seas with significant waves greater than  $H_s$  1.5m as shown by Figure 8 [3, 17].

Figure 8: Example of weather making WT inaccessible with 1.5/2.5m wave heights

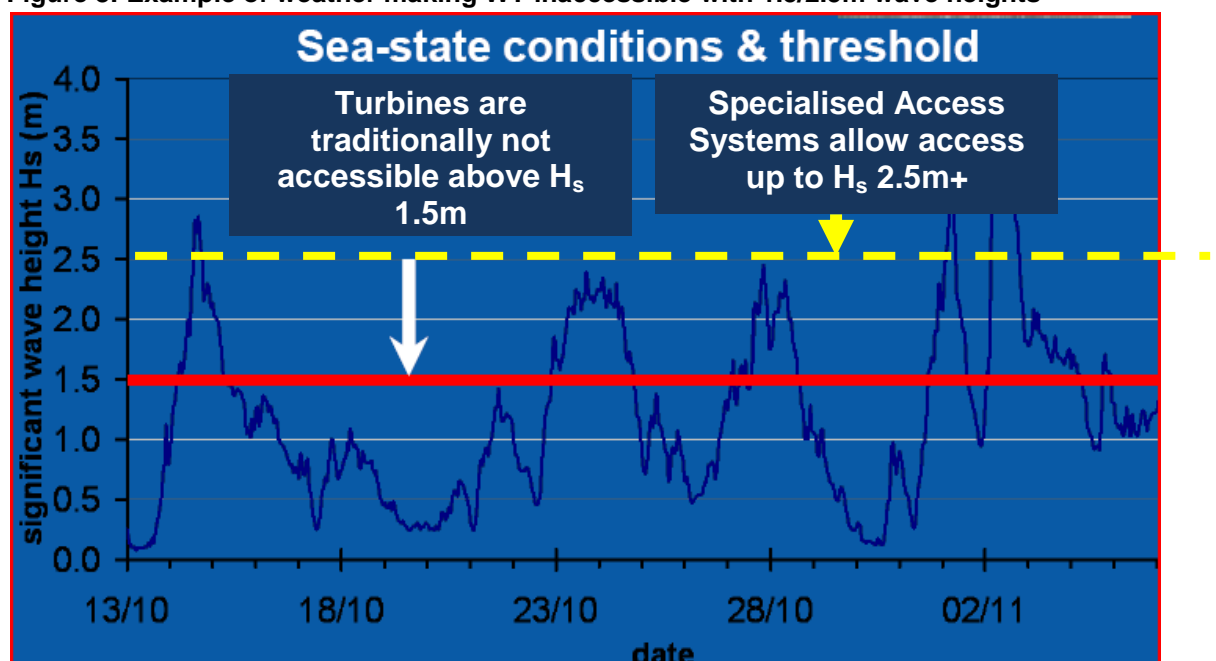

For harsher North Sea conditions, the accessibility with such vessels may well drop to values as low as 60%. Simulations show that in order to maintain wind farm availability above 90% use should be made of systems with a site accessibility of at least 82%, which rules out simple options, such as rubber boats [17]. In addition sailing times to the Dogger Bank, for example, will be in the order of 12 to 24 hours making small vessels unsuitable with respect to accommodation, personnel comfort and ability to cope with rapid weather changes. However it is clear that small vessels would be very beneficial as “Infield” transportation as discussed in Chapter 6.

### **Large Vessels with Access Systems**

These systems envisage the use of an oil field supply vessel (FSV) designed to accommodate 50 – 70 crew and personnel and have many advantages as regards regular access. They are designed to operate in the harsh North Sea environment and are capable of staying at sea for a month at a time if required. In addition they may have dynamic positioning which allows them to hold fixed position with respect to a WT foundation. A large deck area is available for containerised workshops/spares. They can also be fitted with heave compensated cranes allowing safe transfer of containers from a moving vessel to a stationary WT foundation. The key deck item for offshore wind farm operation would be a proprietary human and equipment access or transfer system. There are several proprietary access systems on the market an example of which, the ‘Offshore Access System’ (OAS) has been used successfully in the oil and gas industry and has been proven to achieve safe access with waves of up to  $H_s$  of 2.5m [18]. This would significantly increase offshore WT accessibility as shown by the yellow line in Figure 8. For a baseline wind farm consisting of 80 x 6 MW WTs located 43 km off the coast -simulations have shown that an accessibility factor of at least 82% is required in order to maintain a farm availability above 90%. This supports the case for use of an OAS [17]. Various access systems are discussed further in chapter 6.

## **2.6 Operations and Maintenance**

### **Design Aspects of O&M**

The O&M costs for offshore wind farms are substantially higher than for onshore. O&M costs are predicted to contribute about 25–30% to offshore generation costs, and a considerable percentage will be caused by unexpected failures leading to a requirement for corrective maintenance [19]. These figures emphasize the need to

optimise offshore wind farm O&M. The use of adequate diagnostics based on condition monitoring techniques could be critical to this optimization. The number of inspection visits and corrective maintenance actions must be lowered to reduce related costs and downtime [19]. The O&M demand of an offshore wind farm must be assessed in conjunction with the other design parameters such as the following system aspects [14] Levelised production cost per KWh; Adaption to the specific site; dynamics & structural reliability; installation and commissioning efforts and OWECS availability. The goal being to deliver power quality and quantity persistently ensuring profitability over the lifetime of the offshore wind farm. These parameters are illustrated in the right hand column of figure 7 shown earlier.

O&M activities aim to optimise the availability and capacity factor of a wind farm whilst keeping costs to an acceptable level. Maintenance falls into two broad categories - that which is preventive and that which is corrective. The detailed breakdown of sub categories is illustrated in Figure 9.

**Figure 9: Schematic overview of different maintenance types [19].**

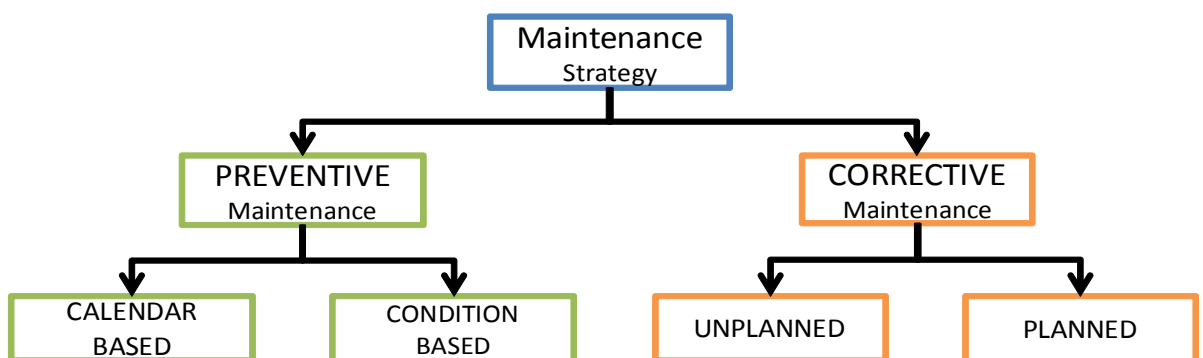

Preventive maintenance consists of:

- Calendar-based maintenance, based on fixed time intervals or on fixed numbers of operating hours.
- Condition-based maintenance, based on the measured health of the system.

Corrective maintenance consists of:

- Planned maintenance, based on the observed degradation of a system or a component failure, is expected in due time and should be maintained before it occurs.
- Unplanned maintenance, is that which is necessary after an unexpected failure of a system or component.

## **SCADA and CMS Systems**

Wind farms are monitored remotely using supervisory control and data acquisition (SCADA) and condition monitoring systems (CMS) and locally by active inspections. Review of SCADA data and prognostic CMS can help to time preventative maintenance before failure occurs. O&M of offshore WTs is still very much in its infancy with each wind farm project having its own approach. As the number of operational offshore units increase, the O&M function will have to be certified and unified to create an offshore wind O&M industry. There are good reasons for understanding in greater detail the performance of operational wind farms. This can be achieved by collecting sufficient, good quality SCADA and CMS data, careful data management and intelligent interrogation to 'finger print' failure modes which in turn will result in the development of a good preventative maintenance program. Combining SCADA and CMS data on operation, alarm status, vibration, temperature and lubricant quality will prove a powerful tool in reaching the desired availability levels required.

SCADA data could be used to graphically represent a wind farm's operation using time-lapse animation, giving a 'bird's eye view' of a wind farm's historical performance over a meaningful time period such as for example, one month.

Figure 10 gives an indication of how a graphic representation of a wind farm may appear in a control room onshore for a 40 WT field [20].

The lack of practical wind industry experience with CMS onshore and offshore to date, has resulted in difficulties in interpreting data and includes the risk of false or missed alarms. One driving factor is that present techniques may not be suited to all types of WTs. A second driving factor is that developing reliable WT condition monitoring techniques requires complex and lengthy collaboration between WT operators and manufacturers in the field [21], which may be precluded by contractual difficulties during warranty periods.

Figure 10: Freeze Frame from a wind farm animation [20].

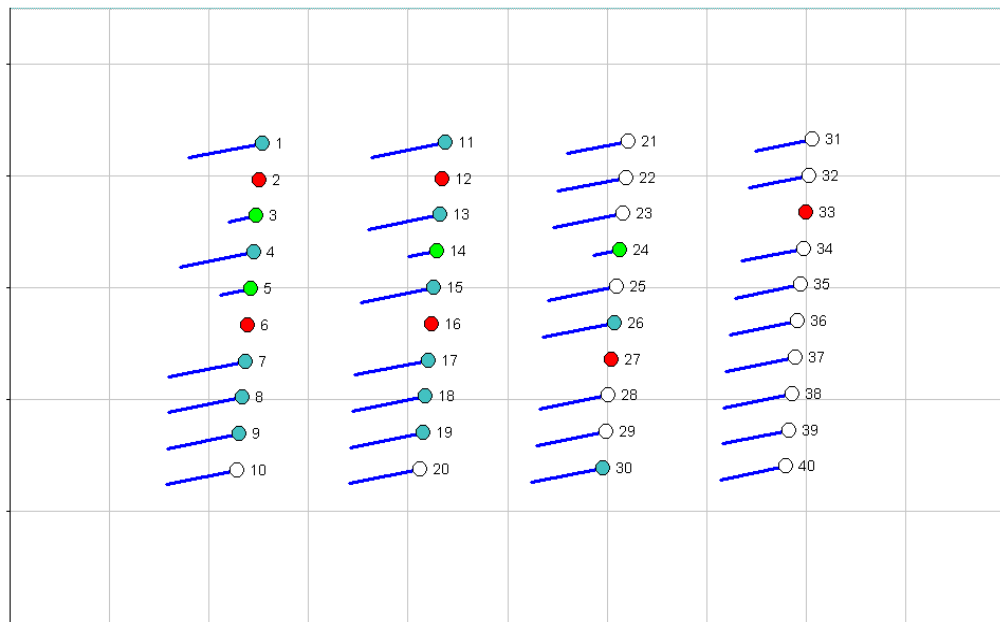

Legend

1	Individual turbine identifying number
●	Turbine not available (awaiting maintenance / repair)
○	Turbine operating at full capacity
●	Turbine operating at restricted capacity
●	Turbine operating & being monitored as an alarm condition has been noted
—	Indication of turbine power output and wind direction

## 2.7 Summary

Having reviewed the literature concerning factors that impact on the availability of WTs and especially WTs placed offshore, the following appear to be the key issues that need to be considered as regards offshore power production:

- That the reliability and availability of WTs and their subassemblies needs to be improved for offshore wind farms.
- An offshore WT requires a customised design rather than adopting an onshore WT design for offshore use.
- Increasing WT size has in the past resulted in lower initial reliability.
- Common standards for the documentation of offshore WT O&M are needed if offshore WT reliability and availability is to be improved.
- Uniformity of O&M databases from offshore WTs is needed if offshore WT reliability and availability is to be improved.
- Improving accessibility to offshore WTs is crucial for making them cost effective.

These points will now be considered in more detail examining Clipper Wind's actual performance data for their onshore 2.5 MW Liberty machine.

### 3 Wind Turbine Taxonomy

A major problem in undertaking this research has been the difficulty in being able to compare like with like as regards WT assemblies and subassemblies. This is because there is no standardisation in the industry of the WT taxonomy and the terms used by WT manufacturers, WT operators, in various studies, or in the available standards.

Table 2 illustrates this by comparing the taxonomy used in one academic report, four national studies, two standards and Clipper Windpower's own categories.

**Table 2: Varying Taxonomy (Collated by Author)**

Durham University	Danish LWK	German WMEP	Swedish Elforsk	Finnish VTT	VGB (MD) Wind Turbine Sys	IEC - 2006 (E) 61400-25-2 WTUR	CLIPPER In-house
Rotor	Blades	Rotor Blades Rotor Hub	Hub	Rotor Blades	MDA Rotor Sys	WROT	*
Air Brake	Rotor Brake	*	*	*	*	*	*
Main Shaft	Shaft Bearings	<u>Drive Mech?</u>	Drive Train	Drive Train & Hub	MDK10 Main/Rotor Shaft	WTRM	*
Gearbox	Gearbox	Gears	Gears	Gearbox	MDK20 Gearbox	WTRM ?	GB
Mech Brake	Brake	Mech Brake	Mech Brake	Brake (Not Specified)	MDK30 Brake System	WTRM ?	PB
Generator	Generator	Generators	Generator	Generator	MKA Generator Sys	WGEN	GEN
Converter	Electronics Inverter	Electronic Ctrl	Control Sys	Control Sys	MKY Control	WCNV	GC, GCU TCU
Yaw System	Yaw System	<u>Drive Mech?</u>	Yaw System	Yaw System	MDL Yaw System	WYAW	YAW, YBS
Hydraulics	Hydraulics	Hydraulic Plnt	Hydraulics	Hydraulics	MDX Hydraulic System	WTUR ?	HPU
Electrical System	Electrics	Electrics	Electrical Sys	Electrical Sys	MDY10 Elec Control Sys	MMXU	PDP, DJB CBMS
Pitch Control	pitch Mechanism	*	Blades/Pitch	*	MDC Blade Adjustment	WROT ?	PCU, EPU
Other	Anemometry Sensors,	Sensors Wind Dir Tracking	Sensors	Heating Slipring Nacelle	MDY	WMET	MET
*	*	*	*	*	MUD Machinery Encl	WNAC	*
*	*	Support/ Housing	Structure / Entire Unit	*	UMD Structure WTG	WTOW	*
*	Other	*	*	Other Unknown	N/A	*	*

\* Indicates no data in this category for the relevant study / standard.

There is little consistency across the board and more importantly certain sub-systems have been grouped differently in each study, making direct data comparison difficult between specific aspects of WTs.

#### 3.1 IEC 61400 Standards

The International Electrotechnical Commission (IEC) is a worldwide organization for standardisation bringing together IEC National Committees [22]. The object of the IEC is to promote international cooperation on all questions concerning standardization in the electrical, electronic and associated fields. The IEC publishes International Standards prepared by Technical Committees established



as a result of representations from National Committees. Any IEC National Committee interested in the subject may participate in the preparatory work for an IEC standard. International, governmental and non-governmental organizations liaising with the IEC also participate in the preparation of IEC standards. The IEC collaborates closely with the International Organization for Standardization (ISO). The formal decisions or agreements of the IEC on technical matters express an international consensus of opinion on the relevant subjects since each technical committee has representation from all interested National Committees. The documents produced are for international use and are published in the form of standards, technical reports or guides. The relevant standard applicable to WTs is IEC 61400 and it contains the following sub-system categories:

- WT General Information (WTUR)
- WT Rotor Information (WROT)
- WT transmission Information (WTRM)
- WT Generator Information (WGEN)
- WT converter Information (WCNV)
- WT transformer Information (WTRF)
- WT nacelle Information (WNAC)
- WT yawing Information (WYAW)
- WT tower Information (WTOW)
- Wind Power plant meteorological Info. (WNAC)
- Wind Power plant alarm Information (WALM)
- WT state log Information (WSLG)
- WT analogue log Information (WALG)
- WT yawing Information (WREP)
- Wind Power plant active power control Info. (WAPC)
- Wind Power plant reactive power control Info. (WRPC)

### **3.2 Reference Designation System for Power Plants Standard.**

The main objective of this standard was to arrive at a sector-specific approach to the naming and labelling of all systems, assemblies and sub-systems in power plants. The Reference Designation System for Power Plants (RDS-PP) results from the further development of the successful Kraftwerk Kennzeichen System (KKS) for the identification of Power Station components [23]. The German company VGB organised a working panel that was jointly developed by

manufacturers and operators and contributed to national and international standardisation activities. It has the characteristic features of a proven identification system which are:

- Applicability to all power plant types.
- Consistency throughout the entire life cycle.
- Identity in sense for all technical disciplines.
- Language independence.

The RDS-PP is based on structuring principles, designation rules and letter codes specified in international standards published by IEC and ISO. It complies with the national/international sector-specific standards for power plants DIN 6779-10:2007-04 and ISO/TS 16952-10. The system also satisfies the requirements of European Directives in terms of:

- Operational safety.
- Ergonomics.
- Procurement.
- Declaration of conformity.

The System is powerful in that it gives a structure for identifying parts of any WT down to the level of individual nuts, bolts and washers. The fact that it is 'Language Independent' does, however, mean that it is not an intuitive system. System, assembly and sub-assembly numbers are used rather than names or abbreviations making it more difficult to implement.

Examples of RDS-PP designators for four types of valve with abbreviations are given below.

- Safety valve            FL
- Isolating valve        QM
- Control valve          QN
- Non-return valve      RM

It can be seen from this that although they are all valve related there is no single letter, for example V, in any valve designator.

### **3.3 Germanischer Lloyd.**

Germanischer Lloyd (GL) has produced a document entitled "*Guideline for the Certification of Condition Monitoring Systems for Wind Turbines*" [24]. It was developed in response to the fact that insurers could find no concrete

specifications in the wind energy sector for certification of WT systems. As such it is not wholly proscriptive for the whole WT and its focus is mainly on the monitoring of the drive train. However for WT producers to achieve certification this forces them to amend their taxonomy accordingly and has some affect on the I/O of the WT. Table 3 below gives some examples of the specific measurements required by GL.

**Table 3: Summary of Germanischer Lloyd CMS measurement requirements.**

<b>Temperatures</b>	<b>Vibration</b>	<b>Miscellaneous</b>
Gear box Oil Inlet	Rotor bearing Radial	Generator Bearing Clearance
Gear box Oil Outlet	Gearbox Ring Gear	Actual Electrical power
External Air	Gearbox Sun Pinion Shaft	Rotational Speed
Main Bearing	Gearbox Output Gear	Wind direction & Speed
Bearing in Gearbox	Gearbox Radial	WT Intervention Messages
Generator Bearing	Nacelle & Tower Radial	Active Yaw Movement
Generator Windings	Nacelle & Tower Transversal	Hydraulic Pump activated
Hydraulic Oil		Metallic Particles in gear box oil

### **3.4 Clipper Taxonomy.**

Clipper Windpower uses a very simple naming system in its taxonomy in so much that the named parts are easily identifiable to English speaking engineers [A]. It is also easy to identify components by their simplified two or three letter abbreviations used throughout documentation. The main sub-systems of the WT and their associated abbreviation are listed below.

- Generator Control Unit (GCU)
- Turbine Control Unit (TCU)
- Pitch Control Unit (PCU)
- Hydraulic Power Unit (HPU)
- Gearbox (GB)
- Generator (GN)
- Power Distribution Panel (PDP)
- Meteorological Sensors (MT)
- Yaw System (YS)

This taxonomy satisfies the requirements of Germanischer Lloyd and is also compliant with the IEC-61400 standard.

### **3.5 Summary**

The main findings as regards issues concerning the structure of a WT are as follows:

- No one taxonomy standard is dominant in the industry. Different countries, companies and even research studies adopt their own nomenclature making direct comparison of data difficult.
- To gain certification of a CMS certain external requirements on taxonomy such as those required by Germanische Lloyd have to be met regardless of the type or design of WT. And
- Clipper is unlikely to adopt the Taxonomy of RDS-PP or IEC16400. However some sort of 'dictionary' to 'translate' Clipper terms into the equivalent IEC or RDS-PP terminology could be advantageous for future data comparison with external sources.

Having determined the structure of the WT and its sub-systems the next chapter will address the structure of the data collected on these individual components during operations.

## **4 Structure of Wind Turbine Data**

The aim is to examine key reliability issues to be considered in the design of Clipper Wind's new offshore WT. Analysis of the raw SCADA data from the 'Cube' for the Liberty WT is critical to identifying current reliability issues [G]. The results can then be used to focus on areas that should be improved for the Britannia WT.

The SCADA data consists of a Versatile Data Acquisition System (VDAS) the system has 434 separate sensor parameters and 480 individual alarm descriptions. SCADA records sensor and alarms at 10 minute intervals and stores them all in the 'Cube' database with the exception of some 2 second data, commonly called 1/2 Hz data. However, when a fault occurs at a given WT, 20 Hz 'burst' data can be collected for a period of about 30s before and 30s after the event that initiated the fault condition.

The block diagrams given in Figures 11 and 12 shows the complexity of the logic used by the Turbine Control Unit (TCU) to control the WT and collect the SCADA data. This is in addition to its role of 'Health' monitoring the WT's sub components.

Figure 11: TCU Control Logic Part 1 [C]

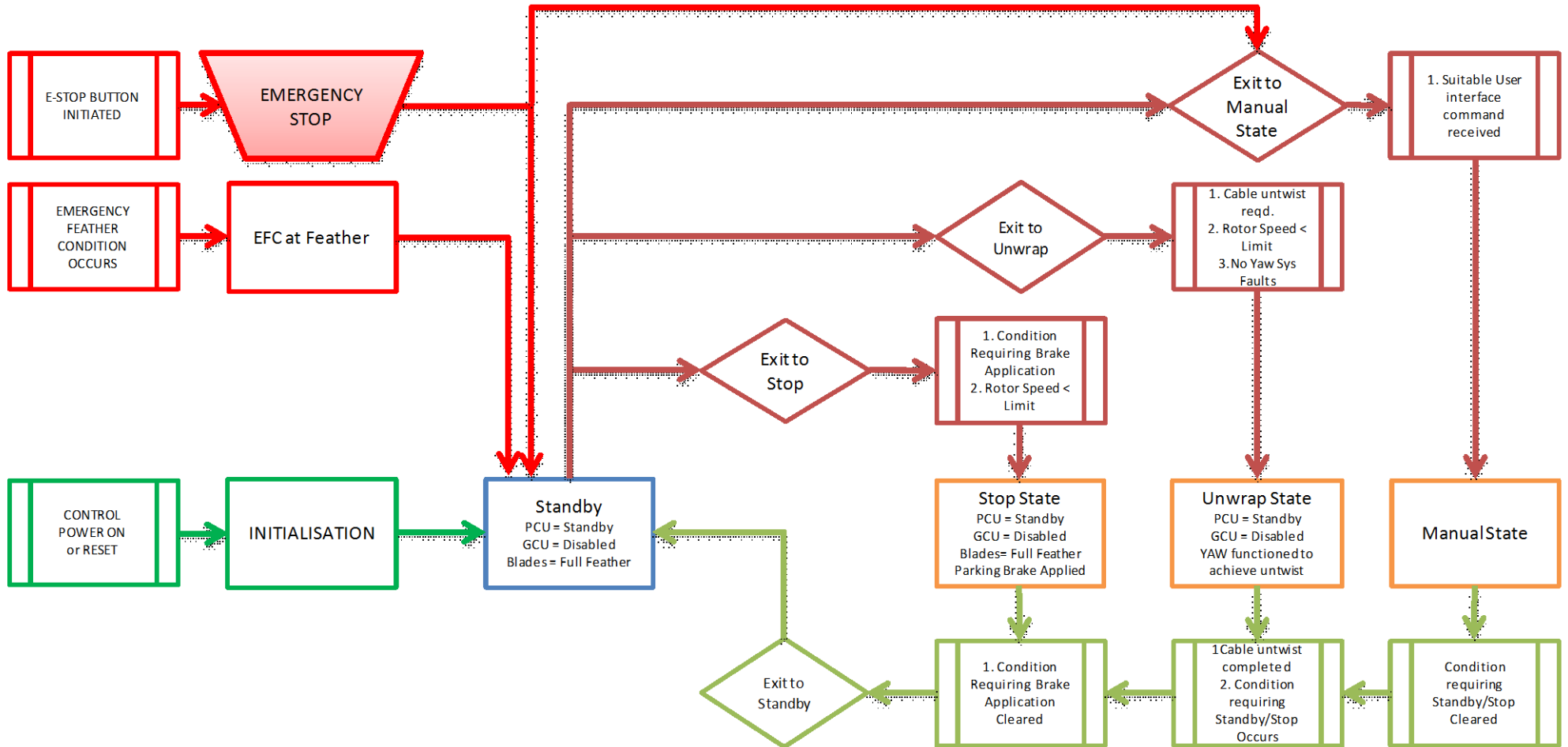
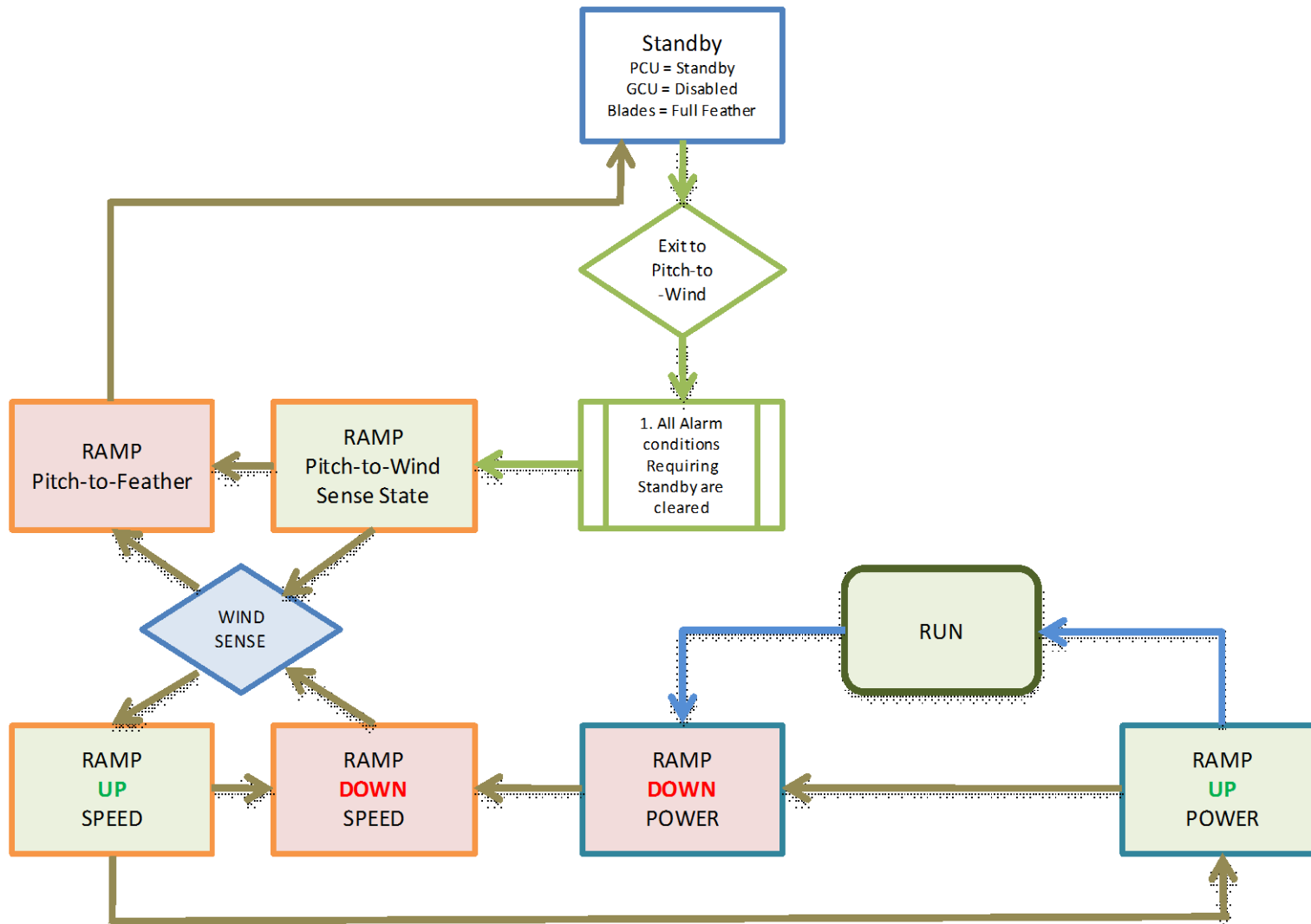

Figure 12: TCU Control Logic - part 2 [C]



#### 4.1 Alarm Number and Type

Most research into reliability in the wind industry concentrates on fault type, fault duration and failure modes of equipment and sub-systems. In this section the number, category and distribution of alarms throughout the WT is investigated to see if any conclusions can be drawn.

Figure 13 presents an analysis from one year's worth of 'Cube' data from Clipper Liberty 2.5 MW variable speed WTs showing the percentage of total detection devices for each sub-system in the WT represented by histogram columns. These columns are further broken down into the three alarm categories:

- Never remote reset the faulted device (Red).
- Remote reset the device after following certain rules that have been applied to that particular fault (Yellow).
- Remote reset the device automatically only taking note of the fault condition (Green).

The number of alarms attributed to each WT sub-assembly as a percentage of the total alarms for the whole WT annually is illustrated by the red dots.

The lost time attributed to each sub-assembly as a percentage of the whole WT's annual lost time is illustrated by the purple dots.

Taking the first subsystem the Generator Control Unit in Figure 13 as an example:

- The total column height is 44.5% - this is the percentage of the total monitoring devices on the WT that are installed on this sub-system.
- The breakdown of this 44.5% is as follows:
  - 32.5% is Red – Fault alarms that cannot be remotely set.
  - 1%+ is Yellow – Fault alarms that can be reset with rules.
  - 1%- is Green – Fault alarms that can be automatically reset.
- The red dot indicates that this sub-system accounts for 15% of the annual alarms for the whole WT.
- The purple dot indicates that this sub-system accounts for 18% of the annual lost time for the WT.



Figure 12: Proportion of alarms by Sub-system - % Annual Alarms & Lost Time Hours v Alarms as % of total on WTG [D]

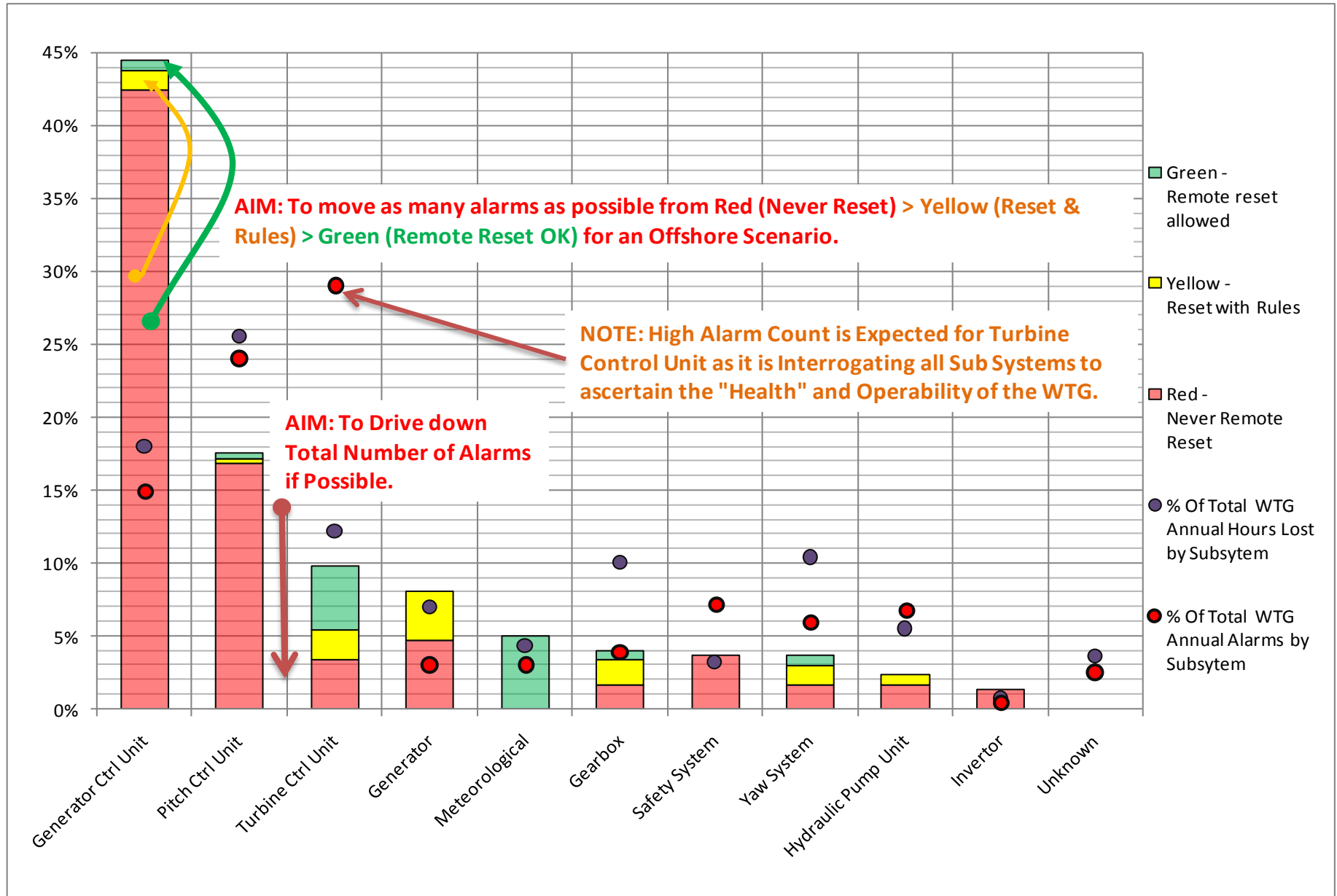

From this research into the alarm type and performance records for the Liberty WT the following points were deduced:

- The GCU accounts for nearly 45% of the total WT alarms yet only 18% of the annual lost hours are attributed to it;
- The PCU has just over 16% of the total WT alarms but just under 26% of the annual lost hours are attributed to it;
- 76.5% of the alarms in total *cannot* be remotely reset and require intervention by maintainers;
- As few as 12% of the total alarms may be *potentially reset* if certain ‘rules’ can be complied with; and,
- Only 11.5% of the total alarms *can be* remotely reset without following any rules or requiring any intervention.

From the above data the following three action items were highlighted:

- Aggregate alarms into groups to make better sense of the ‘whole picture’ of a WT’s health and prevent reacting to single alarms for a system.
- Reduce the alarm severity meaning and moving as many alarms as possible from “Red” (Never remote reset) into “Yellow” (Reset with rules) or “Green” (Remote reset) categories. Also move as many “Yellow” alarms as possible into the “Green” category.
- Where possible at the design phase to eliminate the requirement for alarms and hence reduce the total number of alarms. Ways to do this will be described in more detail in Chapter 7.

#### **4.2 Reducing Total Number of alarms**

One of the main ways to reduce the total number of alarms is through the careful selection or specification of third party equipment incorporated in the WT. Two different commercially supplied generator control units have been used in the Liberty WT. A Xantrex unit with 114 Alarms, and a Magnetek unit with 149 Alarms, that is 30% more alarms than the Xantrex unit yet achieving the same functionality. As the GCU accounts for nearly 45% of the total alarms in the complete WT system it is critical to reduce their number, as far as practically possible, without risking loss of functionality or protection.

It is worth noting that both the GCU and PCU systems are supplied by third party vendors and that they have the highest number of alarms and highest number of the Red alarms that are never remotely reset. It has been noted in maintenance

reports that for many of these non-resettable alarms a vendor-provided engineer has to be called out to investigate and repair the fault at chargeable rates [F]. It is not proven but it is likely that this is to prevent the third parties being held liable for damage to other parts of the whole WT resulting from a fault originating in their own equipment. This will only be solved by careful discussion of requirements and liabilities at the contractual stage. In some cases some alarms cannot be removed as they are a required to satisfy third party certification bodies such as Germanischer Lloyd [24].

### 4.3 Aggregate Alarms

One way of reducing the time addressing alarm issues is to aggregate alarms. The aim of aggregating alarms is not to respond to an individual alarm but to look at a number of interrelated alarms/sensors to determine the actual situation.

Example 1: this can be illustrated using a maintainer’s report consulted as part of the research[F]. An engineer was called out to a WT that had shut down due to the alarm 307 Gearbox oil level low, which is a ‘*never remotely reset*’ alarm. The engineer checked the oil level and found it to be extremely low but within the accepted operating levels. The engineer monitored tower sway against the oil low level alarm. It was found that the alarm was triggering on and off in time with the sway of the tower. The recorded cause was tower sway with a low gear box oil level. In this case because the maintainer was present the oil level was filled to the maximum level.

An alternative action is proposed based on this research, which could have avoided the WT being shut down and an engineer being despatched. That is:

- As the alarm was found to be intermittent it should not have generated an immediate reaction – a 30-40 minute trend (3-4x 10 minute) of signals could have been observed.
- As this is a known problem the following sensor data could have been cross-referenced to determine the WT condition in support of the proposal that low gearbox oil level combined with tower sway caused the intermittent alarm.

Nacelle Acceleration, Axis 1 (Fore/Aft)
Nacelle Acceleration, Axis 1 & 2, Omni directional, Misc.
Nacelle Wind Speed

- To support the belief that there is still sufficient oil for the WT to function adequately the following alarms status could be cross-checked.

300	GB Bearing Temp High 1	Reset w/ Rules
301	GB Bearing Temp High 2	Reset w/ Rules
302	GB Bearing Temp High 3	Reset w/ Rules
303	GB Bearing Temp High 4	Reset w/ Rules
304	GB Oil Temp High	Reset w/ Rules
306	GB Oil Pressure Low	Never Reset

The WT could then have been kept on line. It could have been put under a 'Health' monitoring regime whereby it was observed on a more regular basis in the Control Centre. Replenishing the oil could then have been programmed for the next scheduled visit to the WT if the problem remained manageable.

#### 4.4 Reduce Alarm Severity

Reducing alarm severity is also important to improving the availability and the aim is to achieve two objectives here.

- To challenge as many "Red" Alarms (Never remote reset) into the 'Yellow' (Reset with rules) or "Green" (Remote reset) categories.
- To challenge as many "Yellow" alarms as possible into the 'Green' category.

Example 2: [F] The following rule illustrated in Figure 14 was found in the fault trouble-shooting guide as a temporary measure during commissioning due to the large number of battery problems experienced. "Red" alarms 993/994/995, Pitch Control Battery warning 1/2/3, could be changed from "Red" to "Yellow" by following this simple guideline during normal operations and not just during commissioning.

Example 3: [F] The following solution was found in the fault trouble-shooting guide that would allow the Pitch Motor red alarms 929/930/931, Pitch motor rms 1/2/3, to be changed from 'Red' to 'Yellow' by following some simple rules. The stated cause for getting these three alarms can be 'moisture condensate on the pitch motor windings'. This is a typical failure mode when the WT is started from a cold state if the Pitch Motors have not had power for a period of time and the motor temperature is less than the external ambient temperature. A typical example would be in the early morning after a frosty night.

The solution is to place the PCU in standby state 18 and then allow the Pitch Motor Heaters to operate for at least half an hour before trying the Pitch System again.

Figure 13: Temporary Remote Reset rules for Battery Warning flow diagram.

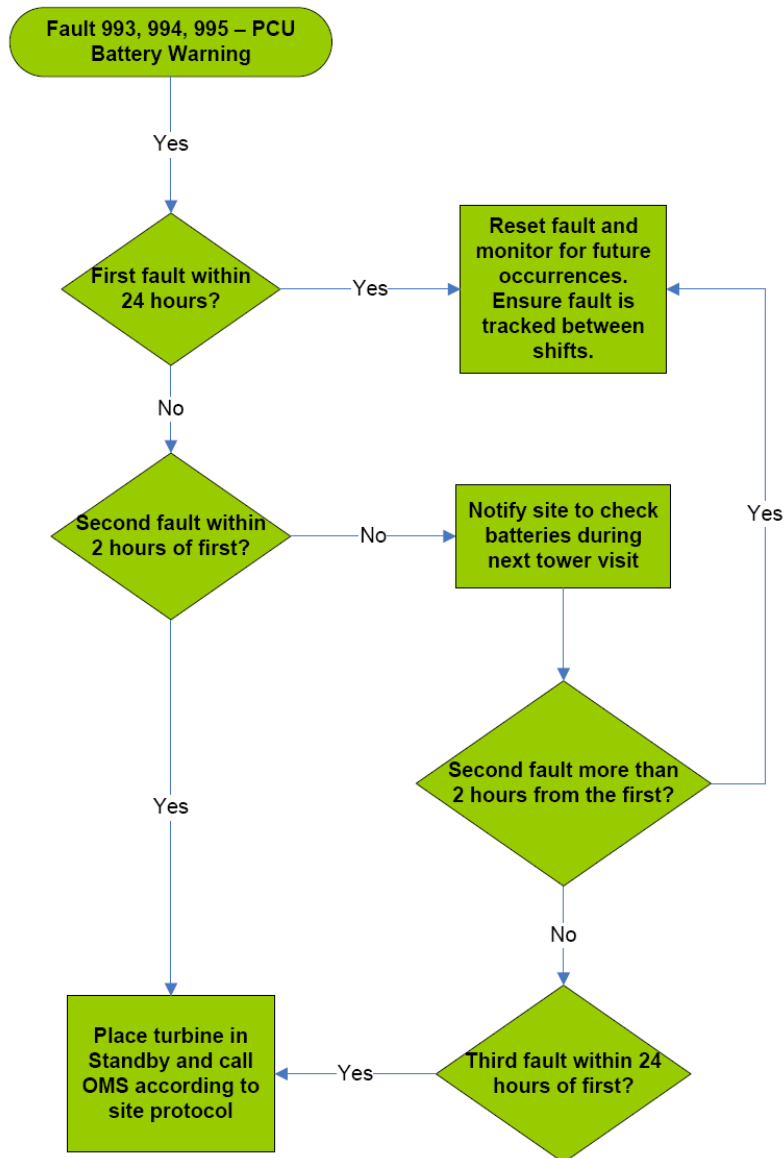

The motor temperature should be monitored to ensure the heaters are operating. So based upon this suggestion the simplified alarm rule may look like that presented in Table 4.

Table 4: Restart rules for PCU Alarms 929/930/931

1	Alarm 929/930/931 activated.
2	Check log and confirm that WT has been inactive for 24hours or more.
3	Check winding temperature is less than ambient temperature.
4	Set PCU to standby state 18
5	Monitor motor temperature and confirm increase in temperature for a minimum of half an hour.
6	Restart the WT and confirm unit is working correctly.

By following this simple rule the WT could be potentially restarted within an hour or so rather than requiring a technician to visit the site, which offshore could be days.

#### **4.5 Automated Reset**

In the case of category “Green” alarms the TCU should be programmed to automatically reset the alarm as no rules apply to these faults. It would appear that they are for WT information-gathering and health-monitoring and are not critical to the safe operation of the WT.

#### **4.6 Summary**

The main points emerging from the above research as regards to the structure of the WT data are:

- Alarms need to be minimised as far as possible without risking WT catastrophic failure.
- The ‘severity’ of alarms should be made as low as practically possible.
- The TCU should not react to single alarms in some cases but should interrogate several alarms to confirm an actual failure.
- Three practical examples have been given of how alarms could be aggregated or reduced in severity.
- ‘Green’ alarms should be automatically reset by the TCU and not require operator intervention.
- Such exercises should be further developed between Clipper Liberty WT designers, operators and maintainers.
- These approaches should be applied to the Clipperwind Britannia WT.

Having established the structure of the sub-systems of the WT and their associated alarms the next step was to analyse the actual fault data and this is detailed in the next chapter.

## 5 Performance Data Analysis

The SCADA data from Clipper Windpower's 'Cube' database was analysed for the first nine months of 2009 [F]. This dataset is for one WT type the Liberty 2.5MW onshore WT. The Clipper data used represents in total 366 WT years of raw unfiltered data compared to respectively 15400 and 5800 WT years of data in Figure 5. (Note: More data became available as more WTs were brought online during the year so this figure is the average for the year.)

Once the analysis had been completed the results were then compared against the results of the ReliaWind dataset [25]. The ReliaWind Project commenced on 15th March 2008, ran over three years and is due to be completed in March 2011. It had a total budget of €7.7 Million, which included €5.2 Million from the EU. The Project's main goal is to usher in a new generation of more efficient and reliable WTs. It provides practical results that can be used by others working in the fields of in WT design, operations and maintenance.

The Project aims to achieve better efficiency for WTs, through the deployment of new systems with reduced maintenance requirements and increased availability. To this end, the project proposes architecture directed at a modular design more immune to environmental conditions, permitting the replacement of components simply and quickly; to improve monitoring systems for components and thus achieve more accurate diagnosis; and to develop preventive maintenance algorithms for failure anticipation. These new technologies will be integrated in future generations of WT components, wind turbines and wind farms.

The data from ReliaWind represents 240 wind farm months for 290 WT years. The ReliaWind data, unlike Clipper, is not raw SCADA data but is extracted from service records, work orders and alarm logs, as well as SCADA, and has been filtered according to a series of agreed rules, for example no fault of less than 1 hour's interruption was included in the failures. The ReliaWind data was reformatted to match the format used for the Clipper data so that the data could be more easily compared. Both the Clipper and ReliaWind data have a detailed but different taxonomy. The ReliaWind data also covers WTs of 2-3MW, similar in size to the Liberty 2.5MW machine, but includes geared, pitch controlled and variable speed configurations.

## 5.1 Cube Data Analysis

The 'Cube' data has been converted into percentages in order to maintain confidentiality of the Clipper data and to help make it comparable with the ReliaWind dataset. The data is for WTs that have completed commissioning and are accepted by the end operator so it does not include start up faults.

Given the 'Cube' data was in a raw some quality assurance and quality control (QA/QC) had to undertaken to the initial results to eliminate erroneous entries. For example on the initial processing of data the following was found in the allocated fault hours against specific generator alarms<sup>2</sup>:

- Fault 421 - DC Power generator 1 = 224hrs
- *Fault 422 - DC Power generator 2 = 1hr*
- Fault 423 - DC Power generator 3 = 117hrs
- Fault 424 - DC Power generator 4 = 122hrs

It is clear that the 422 faults for generator three out of four must be an order of magnitude in error. On further investigation this was found to be an error in the pivot table used for analyses.

## 5.2 ReliaWind v Clipperwind Failure Rate Comparison.

In the following two pages Figure 15 shows the failure rate for Clipperwind's Liberty machine and Figure 16 shows the failure rate for ReliaWind's various machines.

The Clipper and ReliaWind WT fault counts in Figures 15 and 16 show the number of times a particular fault has been triggered during the period. As this data is sensitive and commercially valuable actual count numbers have not been shown. The fault count for each sub-system has been expressed as a percentage of the total for comparative uses.

As noted in Chapter 3 seldom is an identical taxonomy available between two data sets. The same applies to the Clipper and ReliaWind data. ReliaWind data was provided from an external source in a preset format. The author then attempted to duplicate the same format with the Clipper data set so some attempt could be

---

<sup>2</sup> Note that the Liberty turbine is unusual in that it has four separate generators arranged around a single central drive shaft. Details of both the Liberty and Britannia WT are summarised in Appendices A Table A1



made at comparing data. The two data sets do not compare exactly like for like but trends by subsystem can be noted.

Also it should be noted that Reliawind percentage figures for a similar system will always be slightly lower than Clipper for a directly comparable system. This is due to the fact that Reliawind includes three categories not covered in Clippers dataset that account for approximately 4% of the reported failures and downtime in the Reliawind datasets. The three categories are Structural Module, Whole of Farm and CMS to the right of the graph. It is felt that their combined value is so low as to be almost negligible.

Note: These two points also apply to the data set analysed in section 5.3

What is also significant in the ReliaWind dataset is 11% of faults have been classified as purely 'unknown' and not even allocated to any specific subsystem. This separate 'unknown' category is indicative of the filtering that has taken place in this dataset, which is not raw SCADA data. The Clipper 'CUBE' dataset only has 2.5% of 'unknown' faults not allocated to any sub-system. The Reliawind data set also does not account for any event under one hour compared to Clipper which is based on raw SCADA data that is sampled at a minimum of every 10minutes.

Comparison of the fault count data for the two datasets shows some similarity. For Clipper the worst sub-system is the Turbine Control Unit (TCU) at 28%. However it should be noted that some of these are not faults in the TCU itself but are the TCU reacting to faults monitored in other parts of the WT, for which the TCU is a hub. For ReliaWind the Power Module is the worst offender but with a comparable failure rate of 27.7%.

The second worst sub-system for both is the Pitch Control Module (PCU) for Clipper at 24% and the Rotor Module for ReliaWind at 19.2%. On closer examination of the Clipper PCU data by removing the blade related faults (Blade symmetry; FOT; XOT and FLT Loss) the failure rate for the pitch system alone comes to around 20%. For Reliawind 16% of the failures are specifically for the pitch system only (Pitch System is clearly identified within the Rotor Module).

Figure 14: Overall fault rate for Clipper's Liberty WT

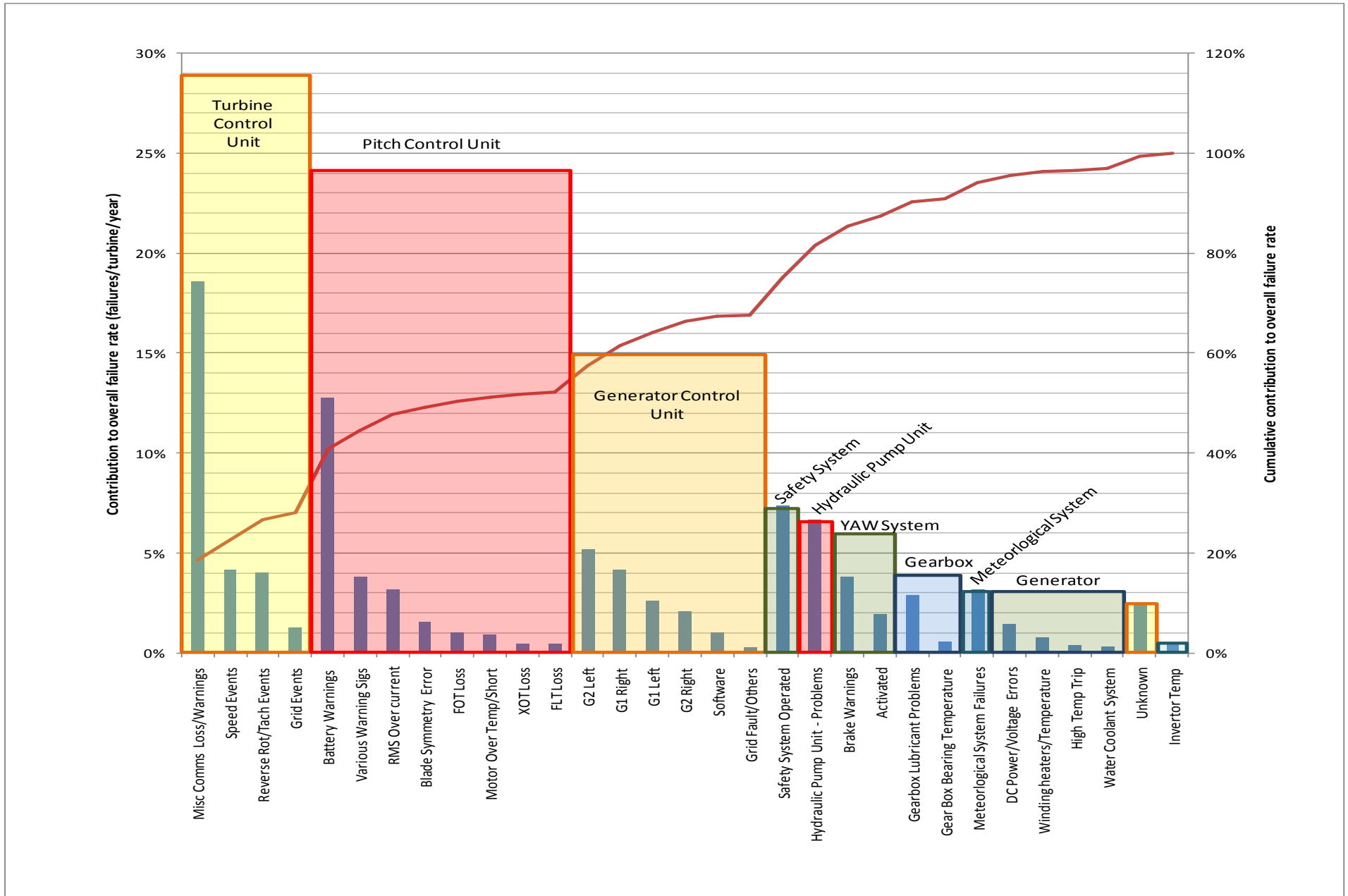
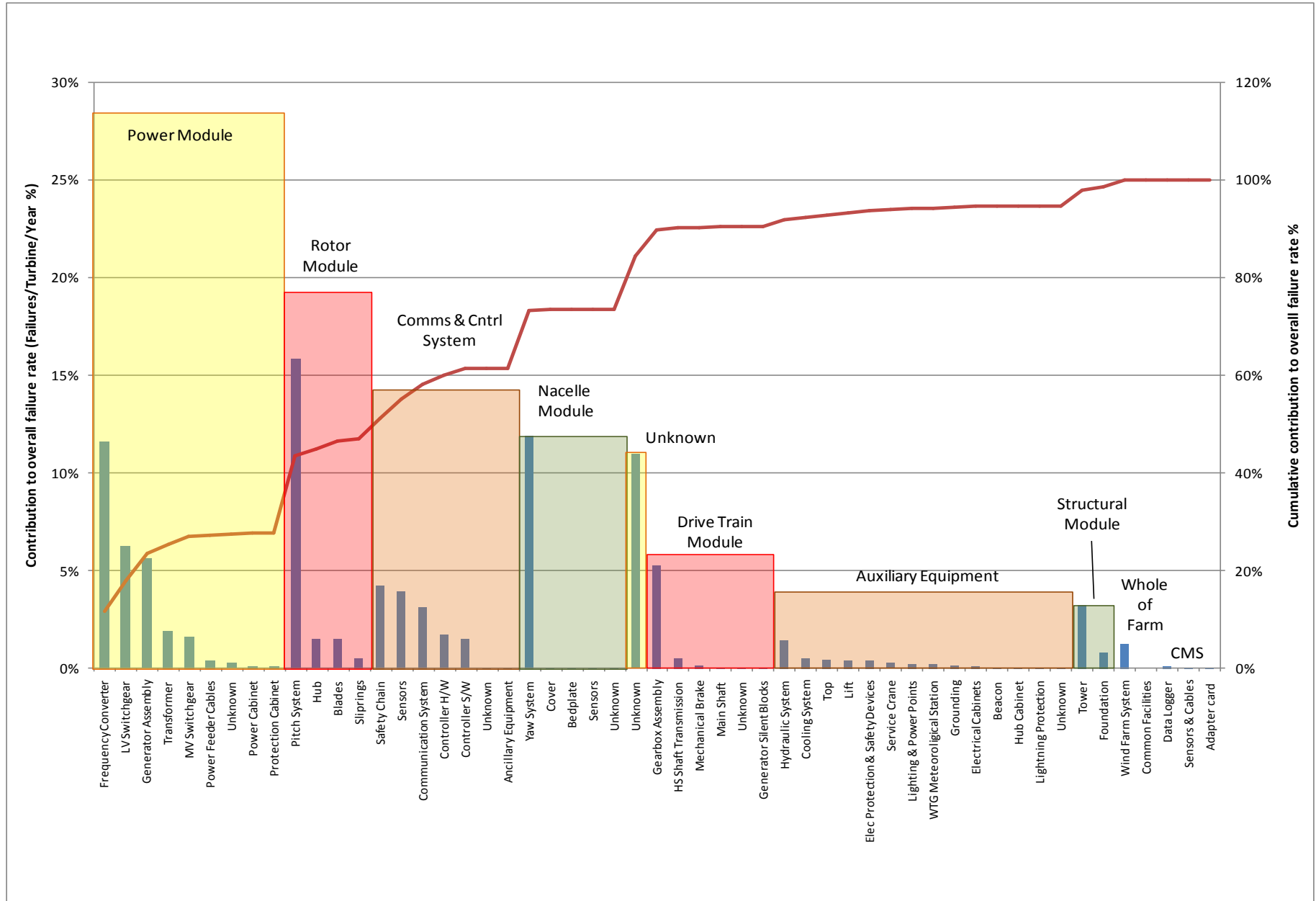

Figure 15: Normalised Fault rate of sub-systems and assemblies for WT's of multiple manufacturers in the ReliaWind database.



A direct comparison can be made for the Safety System. This is 7% for Clipper and just under 4% for Reliawind (Safety Chain is clearly identified within the Comms & Cntrl Module). This is a significant difference between the two data sets.

The Hydraulic System is 6.5% for Clipper and just under 2% for Reliawind (Hydraulic System is clearly identified within the Auxiliary Equipment). This is again a significant difference between the two data sets.

The Yaw System is 6% for Clipper and just over 12% for Reliawind (Yaw System is clearly identified within the Nacelle Module). A significant difference between the two data sets.

A direct comparison can be made for the Gearbox. This is 4% for Clipper and just over 5% for Reliawind (Gearbox is clearly identified within the Drive Train Module). This is a surprisingly comparative figure as it would be expected that Clipper would have a higher figure having four separate generators with associated gearing per turbine against a conventional single generator per turbine.

For Clipper the PCU is shown as the worst sub-system requiring attention, ignoring the TCU as its function is to gather faults. It is also notable that 13% of PCU faults are battery-related. These batteries are part of the three emergency power units (EPU), used to power the individual blade pitch motors in the event of an emergency when normal power is lost. They provide sufficient power to drive the individual blades into the emergency feather condition safely braking the rotation of the WT and allowing the parking brake to be applied. Currently these power packs are sealed lead acid battery (SLB) packs mounted in the hub. They are installed in the hub to be as close as possible to the pitch motors.

### **5.3 ReliaWind v Clipperwind Down Time Comparison**

To help look at the down time for each set of figures the following two pages show Figure 17 with the normalised hours lost for Clipperwind's Liberty machine and then in Figure 18 the normalised hours lost for ReliaWind's various machines.

Figure 16: Normalised hours lost per WT per year to faults in sub-systems for Clipper's Liberty WT.

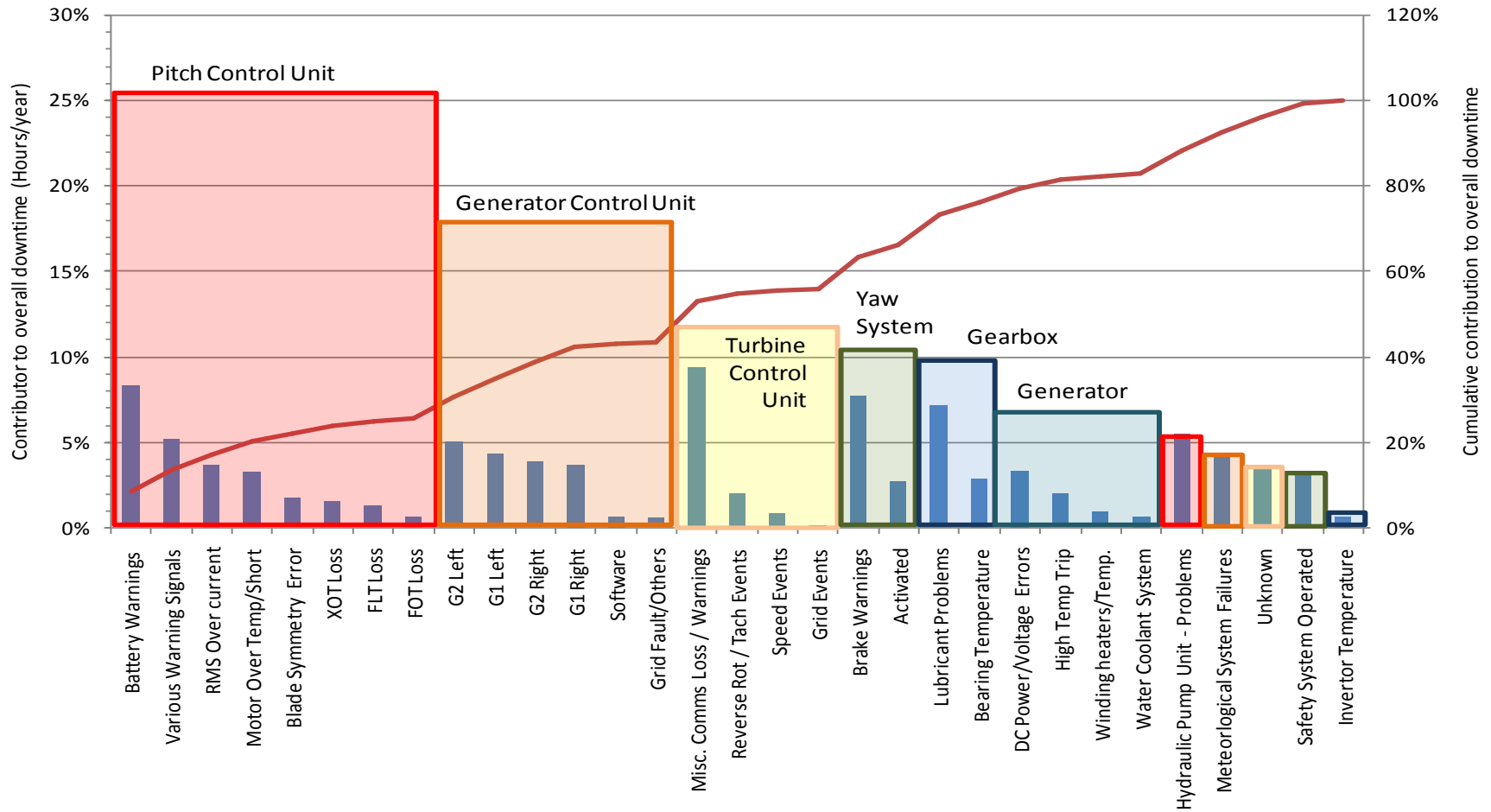
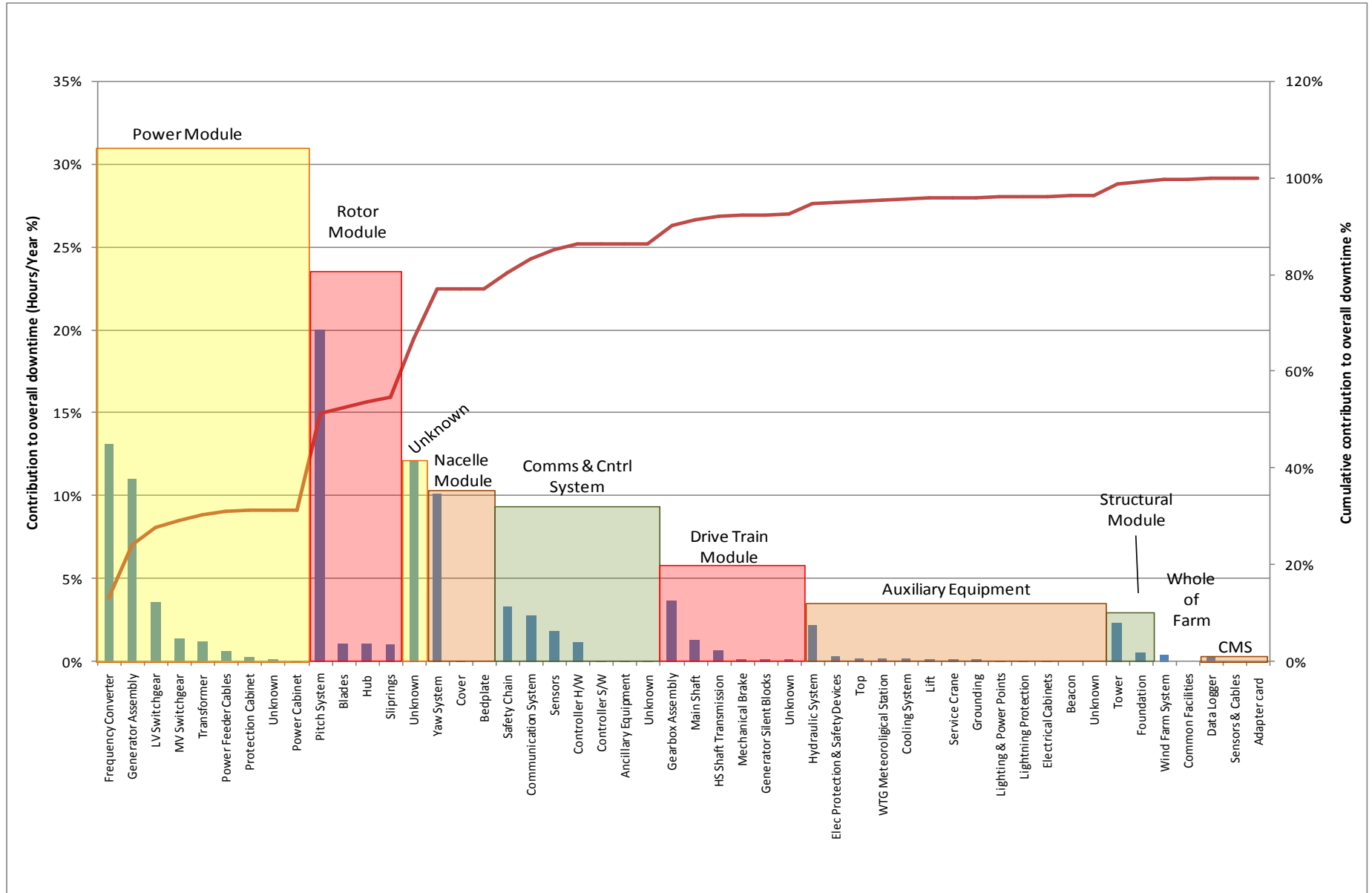

Figure 17: Normalised hours lost per WT per year to faults in sub-systems and assemblies for WTs of multiple manufacturers in the ReliaWind database.



The hours lost per WT in Figures 17 and 18 is the amount of time the WT is not functional for a fault in a particular sub-system. Again this data is sensitive and commercially valuable therefore actual hours lost not shown. The hours lost for each sub-system have been expressed as a percentage of the total as was done for the fault count.

Comparison of the lost hour data shows that for Clipper the PCU was again the worst sub-system at 25.5% of the total attributable lost time. Two fifths of this PCU lost time was accountable to the battery system, this represents 8% of the total WT down time. The Pitch System under the Rotor Module accounted for 23.5% of the lost hours similar in scale to that for Clipper.

On closer examination of the Clipper PCU data by removing the blade related faults (Blade symmetry; FOT; XOT and FLT Loss) the failure rate for the pitch system alone comes to around 20%. For Reliawind 20% of the failures are specifically for the pitch system only (Pitch System is clearly identified within the Rotor Module). This would indicate that all operators are experiencing similar downtime due to Pitch System failures.

For ReliaWind the worst sub-system at 31.4% was the Power Module.

Other comparisons are as follows:

A direct comparison can be made for the Safety System. This is 3% for Clipper and the same 3% for Reliawind (Safety Chain is clearly identified within the Comms & Cntrl Module). This is indicative of the systems performing exactly the same function.

The Hydraulic System is 5.5% for Clipper and just under 2% for Reliawind (Hydraulic System is clearly identified within the Auxiliary Equipment). This is a significant difference between the two data sets.

A direct comparison can be made for the Yaw System. This is 10.5% for Clipper and just over 10% for Reliawind (Yaw System is clearly identified within the Nacelle Module). A surprising result as in the previous fault count data set Reliawind recorded twice the number of faults as compared to Clipper.

The Gearbox is 10% for Clipper and just over 3.5% for Reliawind (Gearbox is clearly identified within the Drive Train Module). This is not surprising as it would be expected that Clipper would have a higher figure having four separate generators with associated gearing per turbine against a conventional single generator per turbine and is therefore more complex to repair.

A further piece of more detailed analysis conducted on the Clipper data, by a fellow researcher at Durham University gives more detail about the Pitch system fault alarms and lost hours. This is illustrated in Figure 19 below [25].

**Figure 18: Breakdown of Fault Alarm Count and Fault Hours for the Pitch System.  
(Courtesy M Clarkson)**

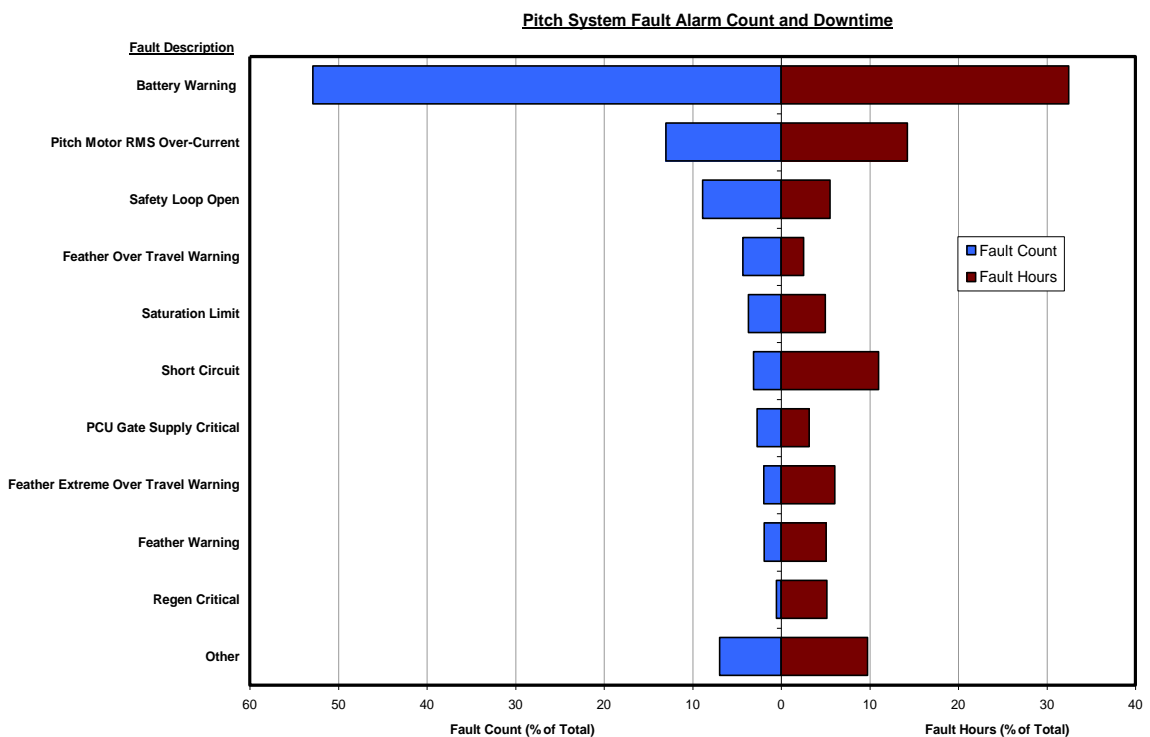

It clearly shows that the EPU batteries are the worst item both in terms of fault count and hours lost. There is evidence from maintenance reports that some of the other faults such as short circuits, damage to the printed circuit boards in the PCU and those described as attributable to acid from damaged EPU battery packs [F]. The fault hours are high for repairs of the PCU mainly due to the difficulty in accessing the Hub from the Nacelle, its restricted working space, the slow and manually-operated lifting devices used there, and the rigorous safety procedures needed to enter the Hub. The confined nature of the hub is shown in Figure 20.



**Figure 19** The three Battery Boxes installed in the Liberty Hub.

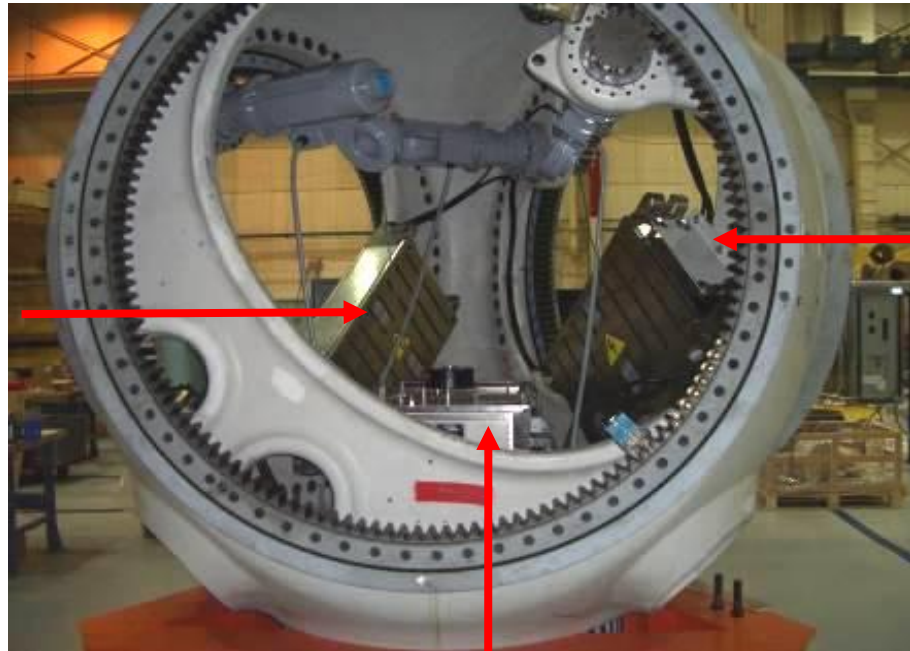

Location of battery boxes, indicated by arrows

#### **5.4 Summary**

The Clipper data and ReliaWind data show a similar pattern in alarm patterns and time lost to faults. The main conclusions for the Liberty WT are:

- The pitch system is shown in both the Clipper and Reliawind data to be the largest cause of downtime.
- Within the pitch system the EPU batteries are shown in the Clipper data to be the most unreliable component.
- A lot of secondary damage is caused by damaged battery packs, for example to printed circuit boards by acid leakage.
- Fault hours are raised due to accessibility issues associated with hub entry to repair pitch system faults.

Having identified the fault pattern and associated them with the failure mode the next item to study is accessibility. Moving the wind farms offshore will lengthen downtime simply due to the site accessibility issues discussed in Chapter 2. The implications of access issues on performance are discussed in further detail in the next chapter.

## 6 Site Accessibility Options

The ability to gain good access to the offshore farms is pivotal to achieving the desired reliability and hence availability. This question of access has become more critical with the latest WT wind farm sites that have been awarded in Round 3. To give some idea of the increasing distances involved Table 5 below gives the distance from land to existing wind farms to date. Table 6 overleaf summarises the distance from 4 United Kingdom East coast harbours to two of the largest fields recently awarded by the Crown Estates in Round 3.

**Table 5: Round 1 and 2 Wind Farm Distances from Shore**

Existing Wind farms after 2005, > 25x WT			nm	km	km	
Cap (MW)	No. of WTs	Wind farm Name	Min	Min	Max	
90	30	Barrow	5.9	7.0		UK
90	25	Burbo Bank	4.4	5.2		UK
90	30	Kentish Flats	7.2	8.5		UK
60	30	North Hoyle	6.4	7.5		UK
60	30	Scroby Sands	2.5	3.0		UK
90	27	Inner Dowsing	4.4	5.2		UK
97	30	Lynn	4.4	5.2		UK
90	25	Rhyl Flats	6.8	8.0		UK
90	30	Robin Rigg A	8.1	9.5		UK
90	30	Robin Rigg B	8.1	9.5		UK
108	36	Egmond aan Zee	6.8	8.0	12.0	NL
120	60	Princess Amalia	19.5	23.0		NL
160	80	Horns Rev	11.9	14.0	20.0	DK
165.6	72	Nysted	5.1	6.0		DK
110	48	Lilligrund	8.5	10.0		SE
Average			7.3	8.6	16.0	

(Source: Various references collated by author)

It is easy to see that physical access is not a major problem for the current sites of wind farms that are 3 to 23 kilometres offshore. A small vessel will take an hour to reach the furthest field and helicopter flying times will be measured in minutes. With the new sites of 30 to 212 Kilometres offshore access will become critical. An

oilfield support vessel travelling from Blyth to the nearest edge of Dogger Bank will take 10 hours sailing time and 17 hours to the furthest edge of the site.

**Table 6: Distance from major UK East coast ports to the two largest New Sites**

Round Three	nm		km	
	min	max	min	max
Distance: Harbour -> Windfarm				
Blyth – Z3 Dogger Bank	100.0	170.0	118.0	200.6
Blyth – Z4 Hornsea	89.0	180.0	105.0	212.4
Tyne – Z3 Dogger Bank	95.0	167.0	112.1	197.1
Tyne – Z4 Hornsea	83.0	175.0	97.9	206.5
Tees – Z3 Dogger Bank	87.0	165.0	102.7	194.7
Tees – Z4 Hornsea	65.0	155.0	76.7	182.9
Humber – Z3 Dogger Bank	91.0	177.0	107.4	208.9
Humber – Z4 Hornsea	25.0	95.0	29.5	112.1
Average	79.4	160.5	93.7	189.4

(Source: Calculated from Google maps by author)

The advantages and disadvantages of various means of physically getting to offshore sites are discussed below .

### **6.1 Helicopters**

Although helicopters have been used as a means of transport to and from European and UK Round 1 and 2 WTs these tend to be near shore up to 20 km from land, for example as at Horns Rev.

The fact that the physical dropping off/recovering of crew members has to be done in daylight (visibility) would also limit the amount of time available to work on the WT especially in winter. Psychologically being left offshore with no cover and being more than 2 hour’s flying time away from base may prove difficult for maintenance crews to accept and result in important health and safety problems if a casualty occurs<sup>3</sup>. Another safety consideration is that the fields further offshore will not be covered by inshore lifeboats and there may therefore be a requirement to have a “Standby Vessel” in field to provide safety cover when using helicopters adding to the cost. Such vessels are currently required in the oil and gas industry.

<sup>3</sup> *It is worth noting that the oil and gas industry has tried to limit the use of helicopters and personnel movements in them to an absolute minimum. This is because historically and statistically this is the most dangerous aspect of work an offshore worker is exposed to. This is based on the authors 20 years of hands on experience with the practices and procedures of major international offshore oil.*

**Figure 20: Examples of offshore access to Vestas V80 WT's at Horns Rev by helicopter**



Examples of the cost per hour of maintenance for two types of helicopters are presented in Table 7 overleaf . The figures in Table 7 show that smaller helicopters tend to be cheaper to hire and run. However, it is likely that offshore maintenance crews will not be less than three persons, for safety reasons. Also the need for a helicopter winch operator indicates that the larger helicopters will be likely to be required for maintenance at these distant sites.

**Table 7: Calculation of hourly maintenance cost using helicopters.**

Four seat Helicopter (Pilot +3)	400 £/hour			
Seven Seat Helicopter (Two Pilots + 5)	1200 £/hour			
<i>Source: www.fly-q.co.uk</i>				
Eurocopter	137 knots cruising speed			
	nm		km	
Distance	min	max	min	max
Blyth - Z3 Dogger Bank	100.0	170.0	118.0	200.6
Blyth - Z4 Hornsea	89.0	180.0	105.0	212.4
Tyne - Z3 Dogger Bank	95.0	167.0	112.1	197.1
Tyne - Z4 Hornsea	83.0	175.0	97.9	206.5
Tees - Z3 Dogger Bank	87.0	165.0	102.7	194.7
Tees - Z4 Hornsea	65.0	155.0	76.7	182.9
Humber - Z3 Dogger Bank	91.0	177.0	107.4	208.9
Humber - Z4 Hornsea	25.0	95.0	29.5	112.1
	79.38	160.50	93.66	189.39
AVERAGE	<b>119.94</b>		<b>141.53</b>	
Flight time out (assume inland +/-17Nm)	1			
Take of landing and drop off/pick up	0.5			
Flight time in	1			
Total Trip	2.5 hours			
Cost 7 Seater	£3,000.00		Cost 4 Seater	£1,000.00
& Return	£6,000.00		& Return	£2,000.00
8 Hour Shift - 3 Travel time = 5 Working Hours				
Cost / Hour	£1,200.00			£400.00

These larger helicopters are significantly more expensive due to running/crew costs. The larger helicopters are also in demand by the Oil & Gas industry so the Wind Industry will be in direct competition for these machines. With the safety briefing, flying time and winching time on site the work period is very limited. As previously noted the payload of spares/tools will also be limited.

In Table 7 only two examples of small helicopters have been considered for the following reasons. There are two limiting factors to the size of helicopter that can be used. First is the rotor size. As illustrated in Figure 21 even for a small helicopter, with a rotor diameter of circa 10m, an extension landing basket is required in order to get a safe stand off for the helicopter rotor from the WT blades. The second is the down draft or “rotor wash” generated by the helicopter whilst hovering. In any helicopter above the small size the strength of the down draft will create unacceptable stress on the nacelle and landing basket.

Table 8 compares various helicopter rotor sizes and useful load capacity which is proportional to the down draft generated.

**Table 8: Comparison of various helicopter sizes**

Name	# Crew/ passengers	Rotor Diameter (M)	Useful Load (Kg)	Range (Km)
<b>*Small</b>				
Bell 206B-3	1/4	10.16	674	693
Eurocopter EC135	1/7	10.2	1,455	635
MBB/Kawasaki BK 117	1/10	11.0	1623	541
<b>* Medium</b>				
Bell 212 Twin Huey	2/13	14.64	2119	439
Eurocopter EC155 B1	2/13	12.6	2301	857
Sikorsky S-76 Spirit	2/12	13.41	2129	639
<b>* Large</b>				
Bell 214ST	2/16	15.85	3638	858
Sikorsky S-92	2/19	17.17	4990	999
Eurocopter EC225 Super Puma Mk II+	2/24	16.2	12633	857
<b>** Heavy Lift</b>				
Boeing CH-47 Chinook	3/55	18.3 (x2)	12495	2252

Source: All accessed 09/05/2011

\* [http://en.wikipedia.org/wiki/Bristow\\_Helicopters\\_Fleet](http://en.wikipedia.org/wiki/Bristow_Helicopters_Fleet)

\*\* [http://en.wikipedia.org/wiki/Chinook\\_helicopter#Specifications\\_.28CH-47D.29](http://en.wikipedia.org/wiki/Chinook_helicopter#Specifications_.28CH-47D.29)

Perceived advantages of helicopters:

- Quick access for assessing maintenance requirements or minor repairs.
- Suitable for close inshore wind farms where the helicopter can be quickly mobilised.
- Fast turn-around for emergency recovery of personnel direct to shore.
- They can operate independent of sea-state

Perceived disadvantages:

- Helicopter platforms on each WT are expensive, even for large WTs.
- The cost of maintenance operations using helicopters may be prohibitive.
- The amount of equipment/spares that can be carried offshore and lowered to the WT will limit the maintenance possible to rudimentary servicing.
- They are still weather dependant due to Fog/ Winds/ Visibility.
- Can only drop off/pick up at the WT in daylight.

## 6.2 Vessels without Access Systems

These vessels have a cruising speed of 20knots so take ½ to 1 hour to get on site where they then remain on standby till the maintenance crew need to return. They normally have a complement of around about 12 personnel and 2 crew. Cooking and toilet facilities onboard make a pleasant working condition for the crews. Their catamaran hull design also makes them very stable.

They have been successfully used, again in near shore wind farms up to 10-20km offshore in Round 1 & 2.

**Figure 21: Examples of access by transfer boats [27].**



These vessels tend to be rated MCA Class 2 allowing them to travel up to 60 nautical miles from a safe harbour. However it is unlikely that they would be used for trips

more than 40 nautical miles from shore because of the need for a sailing time of four hours. Referring to table 6 it can be seen that these vessels would not be able to cover the Dogger Bank and Hornsea wind farms from the main North East cost port facilities likely to be used in Round 3.

**Table 9: Calculation of hourly maintenance cost using transfer boats.**

	Average Day Rate*	£1,500.00	
	Spot Market Fuel £/mt**	£300.00	
12 Hour Trip vessel Rental		£1,500.00	Rental
Fuel Costs			
Sail out & return journey ( 2x 40Nm) <i>(Based on 20knot cruising speed giving 0.4MT fuel used)</i>		£120.00	Fuel Cost
8 hours on location <i>(With no heavy seas and light sailing gives 0.4MT fuel used)</i>		£120.00	Fuel Cost
	Vessel Hire & Fuel Costs / Trip	<u>£1,740.00</u>	
Work Hours/day estimated at 3x 4man crews x 8 hours <i>(This is based on 12 hour shift less 4 hour sailing out &amp; return time )</i>		24	hours
Cost / Hour of O&M work		<u><b>£72.50</b></u>	
* <a href="http://www.thecrownstate.co.uk/guide_to_offshore_windfarm.pdf">www.thecrownstate.co.uk/guide_to_offshore_windfarm.pdf</a> (accessed 10/05/11)			
** <a href="http://www.bunkerworld.com/prices/index/bwi">www.bunkerworld.com/prices/index/bwi</a> (accessed 05/09/10)			
Consumption figures from <a href="http://www.wildcat-marine.com">http://www.wildcat-marine.com</a> . [Accessed: 29th June 2010][27]			

Perceived Advantages: [27].

- Simple marine engines that are easily maintained.
- Low cost with fuel consumption at 100 litres/hour when cruising at a maximum 30knots
- Limited specialist training required for maintenance crews.
- Quick and responsive, already used on sites up to 10 - 20km from shore.
- Could be used as an 'infield' vessel launching from a 'mother ship' or fixed platform.

Perceived Disadvantages:

- Weather dependant, especially on sea state which must be < 1.5mHs, making achieving 98%+ accessibility impossible.
- Transfer from the vessel to the tower is normally basic, the boat butts up against ladder and crew members 'jump' onto the ladders.
- Limited amount of equipment/tools can be transferred to the WT.

### 6.3 Vessels with Access Systems

To achieve the access levels needed to effectively operate an offshore wind farm an oil field support vessel (FSV) is required. The size of vessel with dynamic positioning<sup>4</sup> and a suitable access system has been used successfully in the oil and gas industry to access unmanned offshore platforms.

Figure 22: Example of a field support vessel (FSV) [28].



The vessel pictured has a dead weight of 4,577mt, is 90m long with a deck length of 79m, capable of taking 2,500mt deck cargo. The crane pictured is heave compensated<sup>5</sup> capable of lifting 200mt. Maximum draft is 7.8m. Maximum speed is 16.2 knots and cruising speed is 12 knots (Note respective fuel consumption is 62/29 metric tonnes per day!). The vessel crew is 18 and up to 68 additional personnel can be accommodated if required. It has the ability to stay at sea for five to seven weeks depending on sea conditions and fuel consumption.

Perceived Advantages:

- Will achieve the required level of access needed year round.
- Experience in operating these vessels has been obtained in the oil and gas industry.
- Able to remain on location to take advantage of short weather windows.

---

<sup>4</sup> Dynamic positioning (DP) is a computer controlled system to automatically maintain a vessels position and heading by using her own propellers and thrusters.

<sup>5</sup> Heave Compensation is a hydro-pneumatic system that takes into account vessel heave (Vertical Movement) to ensure the crane hook stays stationary relative to the seabed or fixed object external to the vessel.



- Capacity to carry a large range of spares and heavier components.
- Facilities on board enable crews achieve a longer more 'stable' shift pattern.

Perceived Disadvantages:

- Potentially competing with the oil and gas industry for the same vessels.
- Volatility in the day rate based on demand.
- Volatility in the bunker price for fuel.(FSVs consume large amounts of fuel compared with helicopters or small transfer boats described earlier)

The calculation in Table 10 shows the hourly cost of maintenance using such a vessel. It assumes 4 crews working two 12 hour shifts (2x day / 2x night) and covering two WTs at each shift change. With preshift briefings and preparation, transfer times and rest periods during the shift it is estimated 9 hours useful work can be achieved per crew per shift based on experience from the oil and gas industry.

**Table 10: Calculation of Estimated hourly maintenance of an FSV.**

	Average Day Rate*	£10,000.00
	Spot Market Fuel £/mt**	£300.00
14 Days / Trip vessel Rental		£140,000.00 Rental
Fuel Costs		
Sail out & return journey ( 2x 120Nm)		£6,947.92 Fuel Cost
<i>(Based on 12knot cruising speed giving 29MT/24hrs fuel used)</i>		
1 Day in Port		£431.25 Fuel Cost
<i>(1.5MT for power generation)</i>		
12 days on location		£22,425.00 Fuel Cost
<i>(With no heavy seas and light sailing gives 6.5MT/24hours fuel used)</i>		
		Vessel Hire & Fuel Costs / Trip
		£169,804.17
Work Hours/day estimated at 4 shifts x 9 hours		36 hours
<i>(This is based on 24hour working with 2x day and 2x night shifts)</i>		
12 days / Trip		432 hours
Cost / Hour of O&M work		<b>£393.07</b>
* <a href="http://www.oilpubs.com/oso/article.asp?v1=9323">www.oilpubs.com/oso/article.asp?v1=9323</a> (accessed 05/09/10)		
** <a href="http://www.bunkerworld.com/prices/index/bwi">www.bunkerworld.com/prices/index/bwi</a> (accessed 05/09/10)		
All consumption figures are calculated from Maersk shipping data [28]		

There are two very volatile elements in this costing. First is the vessel day-rate which varies with daily demand and contract duration,. The figure used in Table 10 is from the Oil & Gas industry vessel spot market for a three month contract. Second is the cost of fuel oil which varies with supply and demand. Despite these

variances the calculation above does give an indication that the hourly cost compares very favourably with helicopters, especially for the more distant wind farm sites. The main advantage however is the ability to operate 24 hour working with two 12 hour shifts giving a good 8 – 10 hours of useful work on the WT per shift. Such shift patterns are common in the oil and gas industry so should not be problematic in the wind industry. The access systems available to facilitate the use of these vessels and increase accessibility are discussed in the following paragraphs.

### **Ampelmann System.**

The Ampelmann is a ship-based, self-stabilizing offshore access system that provides safe, easy and fast access to offshore structures by actively compensating the wave-induced motions of the vessel. This innovative system shown in Figure 24 uses the unique combination of flight simulator technology with the latest development in real-time motion measurement equipment. Relative motions between the vessel and the offshore structure make marine transfer of personnel difficult or even impossible as wave heights increase. The Ampelmann solves this problem by constantly compensating all ship-motions providing safe, easy and fast marine personnel transfer from any vessel to any offshore structure.

**Figure 23: Ampelmann Offshore Access System [29].**

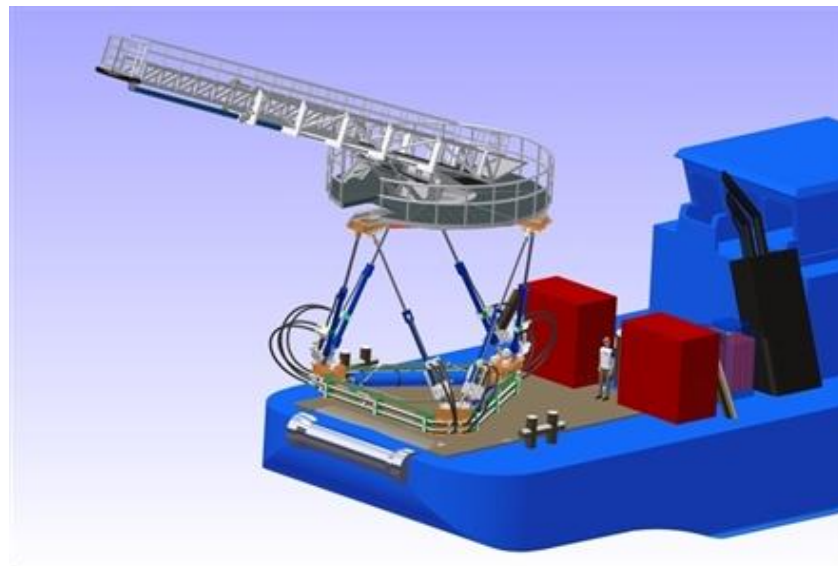

The Ampelmann system saves transfer time, but also increases the weather window from  $H_s = 1,5\text{m}$  for crew boats, see section 7.3 above, to  $H_s = 2,5\text{m}$ . On a 50m multi-purpose vessel, a significant wave height up to 2.5m can be safely managed up to  $H_{\text{max}}=4.5\text{m}$ . This increases the accessibility of offshore

structures in the southern part of the North Sea from a current maximum of 90% to 93%. On a 70m supply vessel, a significant wave height up to 3.0m can be safely managed. This also increases the accessibility level to 97% depending on the size of vessel in use as illustrated in Figure 25.

**Figure 24: Vessel size influences the Ampelmann window of operation**

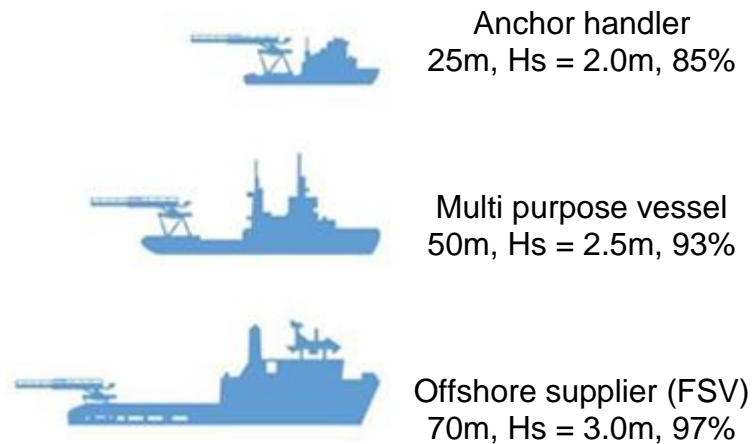

The difference between the various vessels illustrated above are briefly described below.

- Anchor Handling vessels perform anchor handling for semi-submersible drilling rigs and other types of offshore equipment. They tend to have a shorter deck designed to accommodate anchors which makes them less stable. They are however more powerful vessels with a higher bollard pull (power rating).
- Multi purpose vessels are medium sized vessels designed primarily inspection duties and as platforms for Remotely Operated Vessels (ROV) used to inspect subsea cabling and pipelines. Multi-purpose vessels normally have very good station keeping characteristics. They tend not to have the large deck and carrying capacity of a field support vessel.
- Field support vessels (Also known as Platform Supply Vessels) are the work horse of the Oil & Gas industry. They are designed to have large capacity decks to carry material from onshore to offshore installations. They are powerful vessels with good station keeping abilities and handling characteristics. They can also remain on station offshore for extended periods.

Perceived Advantages.

- Achieves the required WT access level required.
- Can be moved with ease between vessels as required.

- Field-proven technology already used offshore in the wind and oil and gas industry.
- No special anchor points or other equipment required on the WT foundation.
- Operated by trained operator, for example vessel crew member or supplier, so no additional training required for maintenance crews.

Perceived Disadvantages:

- The platform remains fixed 'floating' above the vessel's deck. This makes it difficult to run utilities between the ship and the WT. It also means that the platform has to be activated/ deactivated for personnel to transfer between the vessel and WT.
- The hydraulic systems are exposed and vulnerable to damage, although they are backed-up.
- It is a complex system.

**Offshore Access System (OAS)**

The Offshore Access System heave-compensation system<sup>6</sup>, which maintains the end of an access walkway at a constant height, is automatically enabled into 'approach' mode when the walkway is slewed outboard from its cradle. The walkway is then extended and slewed against the vertical pole on the installation. A constant force system ensures that pressure is exerted against the pole before the walkway is retracted to engage the latching mechanism.

**Figure 25: Offshore Access System (OAS) [30].**



<sup>6</sup> Active Heave Compensation System – This system incorporates a motion reference unit in its active hydraulic system which, when engaged, maintains the walkway tip at a constant height relative to the horizon. This allows the walkway to be connected safely in sea states currently up to 2.5m significant wave height.

Once secured, the walkway is then lowered onto the horizontal platform and the heave-compensation system is disengaged. This allows the walkway to “float” between the vessel and the installation. At this point, the walkway is robustly connected to the fixed structure and automatically compensates for the six movement planes of the vessel motion, thereby allowing the safe transfer of personnel to commence.

Perceived Advantages:

- Achieves the required WT access level required.
- Can be moved between vessels as required with ease.
- Field-proven and already used offshore in the wind, oil and gas industries
- The walkway remains fixed between the vessel’s deck and WT foundation. This allows for utilities to be run from the vessel to the WT. It also means that crew members can transit safely between the vessel and WT as required.
- Operated by trained operator, vessel crew member or supplier, so no additional training required for maintenance crews.
- Is a simple and seaworthy system.

Perceived Disadvantages:

- An anchor point needs to be provided on the WT foundation which will probably require annual certification to be compliant with regulatory requirements.

### **Personnel Transfer System (PTS)**

A PTS, as illustrated in Figure 27 can increase the accessibility of offshore structures in the North Sea from approximately 54% to 88% by negating the need for mooring manoeuvres around the offshore structure at sea.

**Figure 26: Personnel Transfer System (PTS) [31].**

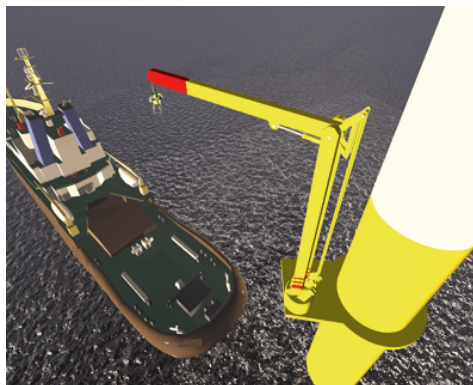

This could dramatically increase the technical availability of offshore wind energy converters. In addition, this system can be used in conditions up to 3.0m significant wave height and up to force 8 winds. Design parameters of the PTS are 500 kg capacity with a 15 m range. By reducing the range, the capacity can be increased for the transfer of heavy goods. Redundancy and intensively trained personnel will help to reduce injuries which can occur during boat transfer. Increased technical availability enabled by the PTS adds significant economic benefit to the offshore wind farm.

Perceived Advantages:

- Requires no specialist equipment to be installed on the vessel.

Perceived Disadvantages:

- Does not achieve the required WT access level required.
- Personnel require specialist training to use the system.
- The system is mounted on the WT foundation and will require maintenance and annual inspection and certification.
- Limited lifting capacity and range of the arm.
- Only a single person can be transferred at a time making crew changing a slow and laborious process.
- Inspecting the arm prior to first use after a long period of inaction whilst being exposed to the offshore elements.

### **MOMAC Offshore Access Systems.**

The offshore access company called MOMAC has two access systems. The first called SLILAD (Sliding Ladder) is a 'Passive' system mounted onto the WT foundation that requires no crew transfer boat modifications. This is shown in Figure 28.

Perceived Advantages:

- Requires no specialist equipment to be installed on the vessel.
- No specialist training required by maintenance crews.

Perceived Disadvantages:

- Does not achieve the required WT access level required
- Requires the installation of additional 'jewellery' onto the WT foundation.
- Moveable ladder and friction brake will require maintenance.
- Compensation for movement is limited by the capabilities of the vessel.

Figure 27: SLILAD: Passive System WT-mounted [32].

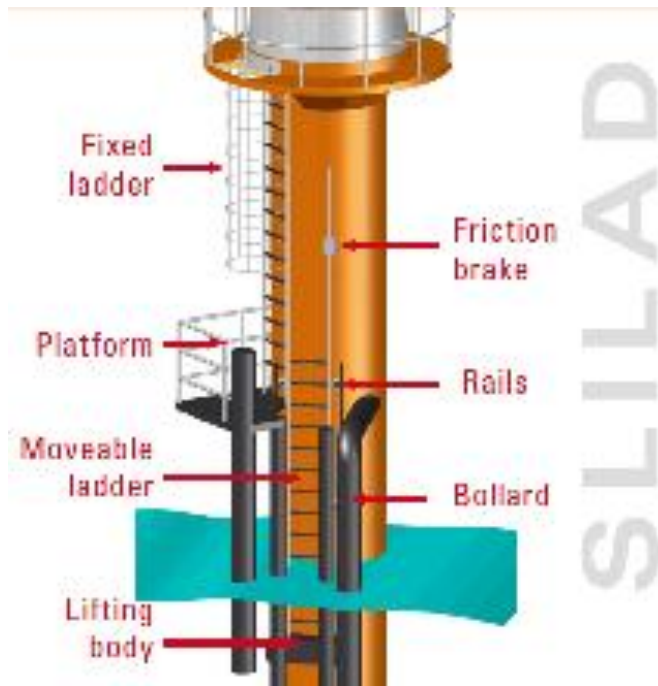

- The vessel locks on to the ladder so that it can follow the heave motion.
  - Personnel step onto the sliding ladder (No relative motion)
  - The vessel disengages from the ladder. The ladder becomes fixed to the tower
  - Automatic tide level adjustment prevents marine growth on the used part of the ladder.
- Simple and seaworthy construction

The second system called the Momac Offshore Transfer System (MOTS) is an 'active' ship mounted system and shown in Figure 29.

Figure 28: MOMAC Offshore Transfer System (MOTS) [32].

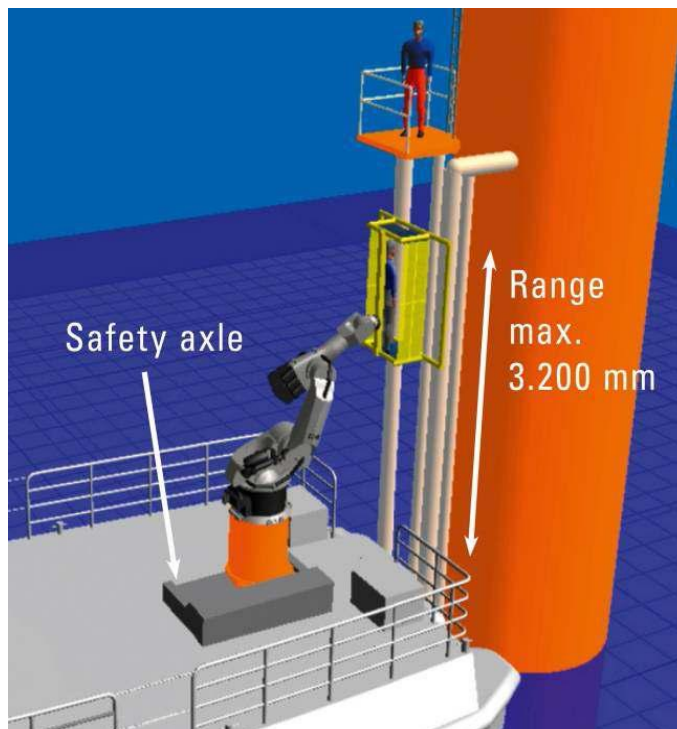

- Self-stabilizing system that provides safe access to offshore structures by actively compensating for the motions of the vessel
- Combination of proven robotics technology and real time motion measurement equipment
- Installation possible in small and fast vessels without Dynamic Positioning (DP)
- Can be used on existing transfer structures without modification
- Safe system, even in case of power breakdown or other failures
- Low-maintenance and seaworthy construction

Perceived Advantages:

- Achieves the required WT access level required.
- Can be moved between vessels as required with ease.

Perceived Disadvantages:

- Personnel require specialist training to use the system.
- Limited lifting capacity and range of the arm.
- Only a single person can be transferred at a time making crew changing a slow and laborious process.
- The vessel still has to approach close to the WT foundation with the indicated 3.2m maximum range it is unlikely that a non DP vessel could be used.

#### **6.4 Mobile Fixed Installation, Jack-up**

Jack-up installations are mainly used during the construction phase of a wind farm. They give a fixed stable base for cranes to be able to precision lift larger components such as Nacelles and blades into position. They also have the advantage of being relatively unaffected by weather conditions once in place with the legs down set on the seabed and the main hull jacked out of the water. They will probably be required during the life of the field for major refits, maintenance or repair jobs that will require large lifting capacity. For more major and longer duration repairs they provide a fixed platform to work from and can be connected directly to the WT foundation by the means of a gangway that allows for easy continuous access between the workshop facilities on the Jack-up and the WT.

**Figure 29: Example of a Mobile Fixed or Jack-up installation as used during the construction of Horns Rev and Kentish Flats wind farms.**





A jack-up as illustrated in Figure 30 will have the following sort of dimensions: Length 120m.x breadth 30m x laden draft 4.43m. It has a deck space in the order of 3300m<sup>2</sup> and capable of carrying in up to 12,250 tonnes when fully laden [33].

Perceived Advantages:

- Will achieve the required level of access needed year round.
- Experience from operating these vessels in the oil and gas industry.
- Able to remain on location to take advantage of short weather windows.
- Capacity to carry a large range of spares and heavier components.
- Facilities on board enable crews achieve a longer more 'stable' shift pattern.
- Provides a stable platform for heavy lifts.

Perceived Disadvantages:

- Can only operate at one WT at a time.
- Requires very good weather to jack up/down and move between locations.

## **6.5 Fixed Installation**

Fixed installations are already in use on some offshore wind farms. Their primary use is to house substations and they were constructed using oil and gas platform techniques. To date they have not been continuously manned and are often only used as refuges in the event of rapid change in weather conditions. In the far offshore fields it is highly likely that these installations could be manned all year round or at least for periods such as maintenance campaigns. The substation platform shown below in Figure 31 is from the Horns Rev wind farm off Denmark. It is designed as a tubular steel foundation and building. It has a surface area of approx. 20 x 28 m, placed some 14 m above mean sea level. The platform shown as an example accommodates the following technical installations:

- 36 kV switch gear.
- 36/150 kV transformer.
- 150 kV switch gear.
- Control and instrumentation system, and communication unit.
- Emergency diesel generator, incl. 2 x 50 tonnes of fuel.
- Sea water-based fire-extinguishing equipment.
- Staff and service facilities.
- Helipad.
- Crawler crane.
- Man Over Board boat (MOB).

**Figure 30: Example of a Fixed Substation Installation at Horns Rev Wind Farm**



For more remote fields the staff and service facilities could easily be upgraded for permanent occupation. The MOB boat could also be upgraded to a transfer boat (See discussion in section 6.3). The advantage of being on site is that short weather windows could be utilised. Minor WT resets can be quickly achieved and more serious outages quickly investigated assessed and the information passed back to shore for action.

### **6.6 Potential Option for the Future**

The future for distant offshore wind farm accessibility will be purpose-built vessels such as shown in Figure 32. With 20 plus year contracts and wind farms with WT numbers potentially into three figures for a wind farm financially it will be worthwhile building such vessels at the outset of a new development.

**Figure 31: ABS+A1 Mobile Offshore Unit DP3 – Concept vessel [34].**



These vessels will be semi-submersible or catamaran hull type design for improved stability and high wave-height operability. They will be dynamically positioned to negate the need to anchor up over seabed cables/utilities and speed up positioning. Accommodation could be for up to 100-150 marine crew technicians and specialists as required. A helideck will allow for crew changes by helicopter or medical evacuation if required. The vessel will be easily capable of staying on station for 1 – 2 months before having to return to port for resupply. As these vessels have yet to be built it is difficult to know how much they will cost to purchase, hire or run.

## **6.7 Weather Prediction**

Weather prediction will be a critical factor in the efficient accessing and operation of far offshore wind farms. Advanced detailed weather reports will be needed to assess accurately when conditions are safe for operators to access the WT or to remain on-site. This is especially important when assessing high risk parameters such as lightning. They will be used to assess in advance when to remove people off-site if severe weather conditions are forecast. Accurate weather reporting will help to decrease overall O&M costs through being able to plan maintenance around forecast downtime when there are periods of light winds and conversely avoid planning maintenance for periods of high winds and rough sea states. O&M costs should also be reduced by maximising weather windows and ensuring that WTs will be accessible before despatching vessels or costly rental equipment.

There are a range of forecasting services available to the wind industry such as VisualEyes™ [35] and Safesee™ [35] from the Met Office. VisualEyes™ is an intuitive, web-based weather alert system designed specifically to help monitor and manage operating conditions effectively on wind farms. Safesee™ is an online, one-stop weather system designed specifically to help the marine and offshore industries with operational decision-making helping to reduce exposure to weather related risk and uncertainty.

Other service providers are companies such as Oceanroutes<sup>7,8</sup> and Fugro<sup>9</sup> that have been providing offshore weather data to the oil industry for many years. These systems could be made available to the Master and Maintenance manager located on the FSV, transfer vessel, fixed installation as well as onshore.

---

<sup>7</sup> Based on the authors experience of both companies in the offshore oil & gas industry

<sup>8</sup> [www.oceanroutes.co.uk](http://www.oceanroutes.co.uk)

<sup>9</sup> [www.fugroweather.com](http://www.fugroweather.com)

## 6.8 Onshore v Offshore Costs

A basic hourly cost of maintenance for onshore wind farms has been calculated in table 11. This allows a comparison to be made with the hourly cost of various offshore solutions discussed earlier in this chapter as has been done in table 12.

**Table 11: Calculation of Estimated hourly maintenance for onshore.**

Average Day Rate*	£250.00
milage allowance**	£0.44
Daily Vehicle rental specialist 4x4	£250.00 Rental
Fuel Costs	
Drive to and from location ( 2x 40 miles) <i>(Based on 40 mile distance from base to windfarm)</i>	£35.20 Fuel Cost
	£285.20
Vehicle Hire & Fuel Costs / Trip	
Work Hours/day estimated at 6 hours <i>(This is based on 8 hour shift less 2 hour drive time)</i>	6 hours
Cost / Hour of O&M work	<b>£47.53</b>
* www.hertz.co.uk (accessed 10/05/11)	
** Clipper Windpower Expense allowances (accessed 10/05/11)	

**Table 12: Comparison of hourly maintenance costs based on transportation cost.**

Transportation method	Cost	Factor
Onshore cost	£47.53	1.00
Offshore Transfer Boat	£72.50	1.53
Offshore Field Support Vessel	£393.07	8.27
Offshore Small Helicopter	£400.00	8.42
Offshore Large Helicopter	£1,200.00	25.25

Table 12 clearly illustrates that the cost of transportation offshore is anything from 1.5 times to up to 25 times more expensive than that onshore depending on the mode of transportation. This comparison assumes that the maintenance work carried out is of equal value. It does not however take into account the fact that offshore workers tend to be paid special additional allowances and are therefore more expensive than their onshore counterparts.

It also shows that transfer boats are by far the cheapest means of accessing offshore WT, but suffer from limited range and reduced weather operating window.

Surprisingly FSVs and small helicopters have comparable costs, but with their associated advantages and limitations as discussed earlier.

## **6.9 Summary**

For the bigger offshore wind farm sites, such as Dogger Bank and Hornsea, their size and distance offshore means that no one method from those described above will solve the access problem. It is more likely that several systems will be used at various stages in the wind farm's life, depending on the time of year and prevalent weather conditions. Helicopters may be used for rapid minor intervention and 'scouting' trips to assess the extent of damage or nature of faults. Substations may have permanent or partial occupation with small dirigibles or catamarans to move about the field doing light maintenance and fault assessment. The work horse for the majority of the maintenance is likely to be an FSV with access system due to its ability to stay on station and carry considerable spares. Specialist Jack-up vessels will probably be required for major overhauls. The most likely future option given the size of these large fields, the extent of their planned life and the number of WTs involved will no doubt be specialist built vessels designed for the wind industry

## 7 Discussion

As far back as 2005 statements such as that given below have indicated that WTs have been designed to make sure that the system always remains in a safe state.

*“The classical principle of wind turbine control and monitoring is to ensure that the wind turbine is always in a safe state – this is not automatically the same as ensuring that the operating time is maximised” [36].*

However as the second part of the statement correctly states, this quest for keeping the machine safe should not mitigate against effective operating time. Operators locating WTs offshore will demand the maximisation of operating time.

In the following paragraphs the critical factors influencing maximisation of operating time without compromising safety will be discussed and some examples of proposed solutions and improvements suggested.

### 7.1 Design

The findings discussed in previous sections have shown that operations and maintenance for offshore WTs must be considered at the design phase of a WT as this will be critical to improving its reliability and availability offshore [37].

The findings have shown that in the first instance Clipper should concentrate on the Electric Pitch System as this has been responsible for 25% of all fault down time in the Clipper Liberty WT and this is in agreement with the results from Reliawind.

In Chapter 5 analysis of the SCADA data showed that the worst offending system for poor reliability and lost time was the EPU of the pitch system. Currently the EPU consists of sealed lead acid batteries (SLB) mounted in the hub. The SLB packs are mounted in the hub so as to be as close as possible to the pitch motors that they operate during an emergency shutdown situation. This is to reduce as far as practical the connections between the SLBs and pitch motors as they are designed to provide independent redundancy for the operation of each blade. This means that the batteries are subject to rotational forces and other shock loads which are not beneficial to the effective performance of lead acid batteries.

In the design of the 10MW Britannia offshore WT as a first example of O&M improvement, SLB battery packs have been dispensed with and ultracapacitors will be used in the EPU instead. These ultracapacitors are especially suitable for offshore and remote wind power applications because of their high reliability, efficiency and operating lifetime. They are however expensive due to the specialist materials used in their manufacture [38]. Ultracapacitors are viewed as maintenance-free devices that do not require costly test runs and expensive management systems unlike batteries, which require ongoing evaluation of their state of health (SOH) and state of charge (SOC). An additional advantage of using ultracapacitors is that the alarms associated with monitoring the three EPU batteries SOH and SOC will no longer be required. Figure 33 illustrates an ultracapacitor sub-module for a 1MW rated WT. It is constructed of 32 separate 2.5V capacitors giving a nominal total voltage of 75 VDC. To obtain the standard nominal voltage of 300 VDC used for a 5 MW WT with rotor diameter of up to 110 m, four 75 V sub-modules are connected in series [38].

**Figure 32 Ultracapacitor EPU sub module for a 1MW rated WT (Containing 32 capacitors)**



A second proposal for improving WT O&M through design would be the use of a forward-looking laser-based wind sensor to measure wind speed and direction. WTs currently operate reactively to the wind because the anemometers are mounted at the back of the nacelle in the WT's rotor wake. This means that current anemometers are measuring the disturbed wind flow in the wake of the blades. These aerodynamic or ultra-sonic anemometers detect the wind speed and direction, averaging out variations and providing control signals to the pitch and yaw system to adjust the WT's operation. The resultant averaging and time delay, often several minutes long, means that the WT is operating reactively the wind. Therefore there are yaw and pitch misalignments which generate unnecessary blade, yaw and tower stresses, causing premature wear and damage to themselves and key WT components such as the pitch mechanism.

A forward-looking, laser-based wind sensor would address these issues enabling the WT to react to wind conditions at 100m to 200m out before it reaches the WT adjusting the WT's attitude accordingly. An example of an externally mounted laser is shown in Figure 34. This particular laser is a stand alone model that has been added to an existing WT for a trial. Ideally the laser would in future be designed into the hub assembly so as to remove blade interference completely. This technology is currently expensive but costs would reduce as installed numbers rise.

**Figure 33: A forward looking laser used to proactively measure wind speed [39].**



### **Failure Modes and Effects Analysis**

A successful Failure Modes and Effects Analysis (FMEA) activity helps to identify potential failure modes based on past experience with similar products or processes [39]. This enables failures to be designed out of the system with the minimum of effort and resource expenditure, thereby reducing development time and costs. It can also be used to model proposed improvements to see if they would prove robust enough. One area that could be the subject of an FMEA would be to examine the proposal to move the pitch control unit EPU batteries or ultracapacitors out of the hub into the nacelle. This proposal would increase the slip ring complexity between the EPU and the pitch motors introducing a potential weak link which could be quantified by carrying out an FMEA on the two arrangements. If this change is feasible it would make the EPU more easily accessible for repair or maintenance, the EPU would not be subject to the dynamic



loads currently experienced in the hub and it would be in the climate controlled environment of the nacelle.

## **7.2 Operational Strategy**

As stated in the introduction the classic principle of WT design has always been to ensure the WT remains in a safe state which is not the same as maximising operating time. With wind energy providing a greater percentage of the overall electrical energy input into the grid and the increased focus from operators on maximise operating time having the correct operational strategy is critical. The correct strategy offshore is even more important due to the problems of accessibility.

One of the main challenges to stream-lining operational activities is the volume of data that currently needs to be analysed. In Figure 35 the author has collated from Clipper data the current information flowing around a wind farm [B,C,D,E and F]. It can be seen that the amount of data and “Handling” points is very complex. This complexity when multiplied by the large number of WTs in a wind farm and a large volume of SCADA data per WT becomes a challenging management task.

The Clipper ‘CUBE’ database only records SCADA data. Maintenance and repair reports are held on separate data base as is design information. Data also sits under various “Custodians” in different locations. For example in Figure 35 the following applies:

- The purple boxes to the top right of the diagram are data provided by external sources (Vendors and industry)
- The dark blue boxes to the lower right are the design data produced during the design of the WT and ongoing upgrade works (Geographical location 1)
- The light green input box at the bottom of the diagram is the team that deals with long term asset management and warranty issues (location 2)
- Above this, in orange, is the maintenance controllers they organise scheduled routine maintenance and unscheduled repair work. (location 3)
- Above this, in red, is operations control room which monitors the health of the WT and controls their output to the grid on a continuous basis (location 4)
- To the top left, in lilac, is the field owner/operator who also requires access to certain data for contractual reasons (Geographical location 5)

Figure 34: Movement of Information around a Wind Farm. [B, C, D, E,F]

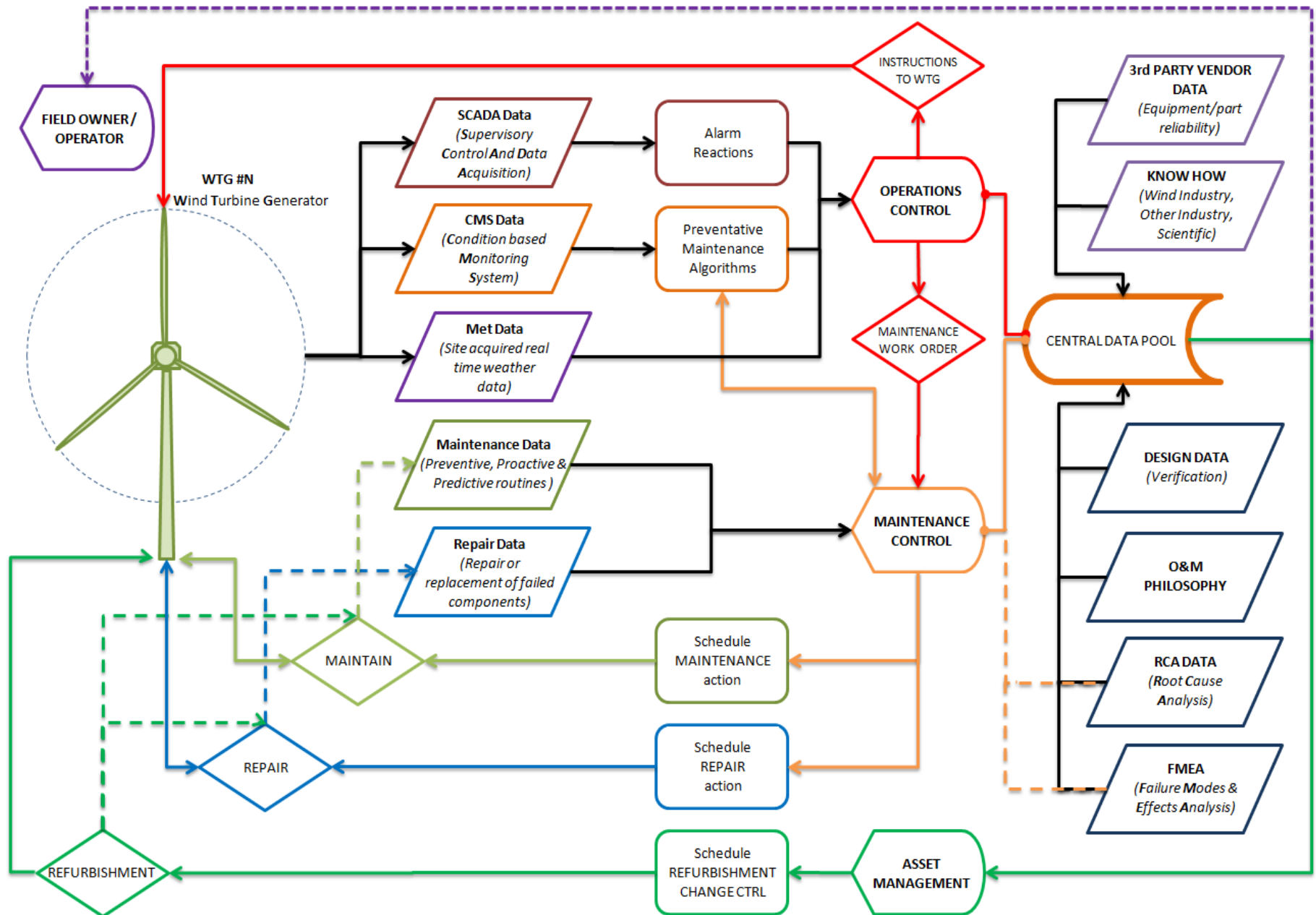

Often several of these locations will be cross accessing databases. For example designers will want to access maintenance and repair data. Currently this is not easily achieved as currently what does not exist but is proposed and illustrated in Figure 35 acts as a central data pool. Provision of such a central data pool or “Super Cube” would hopefully improve information flow, access and analysis for all parties.

### **7.3 Maintenance Strategy**

The maintenance strategy for offshore wind farms will have to be much more carefully planned than is currently the case for onshore, both because of the likelihood of a higher number of failures but also because weather affects access as shown in earlier sections. The overall cost of access to offshore WTs is much greater than that of access onshore which will have a significant effect upon the relative cost of maintenance between the two. Also the journey time to the WT is much greater. Onshore MTTR is often measured in hours as maintenance crews may already be on-site maintaining another WT so their transit time to the WT needing repair is negligible. Offshore MTTR is likely to be measured in days due to access problems.

What has also become apparent during the course of this research is that maintenance and repair work is not well documented. What is needed to make the job of maintenance technicians easier is to have more structured information gathering on faults/repairs. An electronic maintenance report format could help with this and could be installed on either a hand-held device or laptop used by the maintenance technician on-site and then transmitted to headquarters centrally and stored for later analysis. An example of such a report taken from the German WMEP programme [11] is given in Figure 36.

Figure 35: Example format of an Electronic Maintenance & Repair report

***** (Company name)		Work done on:		Report No:				
<b>Maintenance and repair report</b>		3	5	2011				
		Date	Month	Year				
Post code	Plant ID number							
Operator								
Wind Turbine manufacturer & model								
<b>Cause work</b>			<b>Cause of malfunction</b>					
<input type="checkbox"/> Scheduled maintenance (only examination and functional check) <input type="checkbox"/> Scheduled maintenance with replacement of worn parts or repair of defects <input type="checkbox"/> Unscheduled maintenance or repair after malfunction			<input type="checkbox"/> High wind <input type="checkbox"/> Grid failure <input type="checkbox"/> Lightning <input type="checkbox"/> Idling <input type="checkbox"/> Malfunction of control system <input type="checkbox"/> Component wear or failure <input type="checkbox"/> Component loosening <input type="checkbox"/> Other cause <input type="checkbox"/> Unknown cause					
<b>Down times</b>			<b>Effect of malfunction</b>					
<input type="checkbox"/> Not stopped <input type="checkbox"/> Stopped From 2 2 2011 To 3 4 2011 Date    Month    Year Reading of hour counter:			<input type="checkbox"/> Overspeed <input type="checkbox"/> Overload <input type="checkbox"/> Noise <input type="checkbox"/> Vibrations <input type="checkbox"/> Reduced power output <input type="checkbox"/> Causing follow up damages <input type="checkbox"/> Plant stoppage <input type="checkbox"/> Other consequences					
<b>Cost according to calculation</b>			<b>Removal of malfunction</b>					
Material _____ E Labour _____ E Journey _____ E Total cost (Incl. tax) _____ E			Faultless operation without later repair: <input type="checkbox"/> Control reset <input type="checkbox"/> Changing control parameters					
<b>Comments</b>			<b>Repaired or replaced components:</b>					
			<input type="checkbox"/> Rotor hub <input type="checkbox"/> Hub body <input type="checkbox"/> Pitch mechanism <input type="checkbox"/> Pitch bearing <input type="checkbox"/> Rotor blades <input type="checkbox"/> Blade bolts <input type="checkbox"/> Blade shell <input type="checkbox"/> Aerodynamic brakes <input type="checkbox"/> Generator <input type="checkbox"/> Windings <input type="checkbox"/> Brushes <input type="checkbox"/> Bearings <input type="checkbox"/> Electrical system <input type="checkbox"/> Inverter <input type="checkbox"/> Fuses <input type="checkbox"/> Switches <input type="checkbox"/> Cables/connections <input type="checkbox"/> Sensors <input type="checkbox"/> Anemometer/Wind vane <input type="checkbox"/> Vibration switch <input type="checkbox"/> Temperature switch <input type="checkbox"/> Oil pressure switch <input type="checkbox"/> Power sensor <input type="checkbox"/> Rev counter <input type="checkbox"/> Control system <input type="checkbox"/> Electronic control unit <input type="checkbox"/> Relay <input type="checkbox"/> Measurement cables and connections			<input type="checkbox"/> Gear box <input type="checkbox"/> Bearings <input type="checkbox"/> Gear-wheels <input type="checkbox"/> Gear shaft <input type="checkbox"/> Sealings <input type="checkbox"/> Mechanical brakes <input type="checkbox"/> Brake disc <input type="checkbox"/> Brake pads <input type="checkbox"/> Brake shoe <input type="checkbox"/> Drive train <input type="checkbox"/> Rotor bearings <input type="checkbox"/> Drive shafts <input type="checkbox"/> Couplings <input type="checkbox"/> Hydraulic system <input type="checkbox"/> Hydraulic pump <input type="checkbox"/> Pump motor <input type="checkbox"/> Valves <input type="checkbox"/> Hydraulic pipes/hoses <input type="checkbox"/> Yaw system <input type="checkbox"/> Yaw bearings <input type="checkbox"/> Yaw motor <input type="checkbox"/> Wheels and pinions <input type="checkbox"/> Structural parts/Housing <input type="checkbox"/> Foundation <input type="checkbox"/> Tower/Tower bolts <input type="checkbox"/> Nacelle frame <input type="checkbox"/> Nacelle cover <input type="checkbox"/> Ladder/lift		
			<b>The operator</b>			<b>Main component exchanged</b>		
Place/Date _____ Signature _____			Please check if complete component is exchanged <input type="checkbox"/> Nacelle <input type="checkbox"/> Rotor blades <input type="checkbox"/> Rotor hub <input type="checkbox"/> Gear box <input type="checkbox"/> Generator <input type="checkbox"/> Yaw system <input type="checkbox"/> Tower <input type="checkbox"/> Control system cabinet <input type="checkbox"/> Grid transformer					

### Condition Monitoring System [E]

The intent of a Condition Monitoring System (CMS) is to identify significant degradation of the WT before a catastrophic failure occurs and feed data to a Condition Based Maintenance (CBM) system. The CMS should be designed to record vibration data, wear debris, and revolutions/minute data.

The CMS would have three alarm levels, warning, alert and danger, which represent an increase in urgency depending on the situation of the alarm. These alarm levels require a different amount of additional data from other sources to confirm or increase the recommended response.

- Level 1: “Warning” means parameter levels have increased above normal, however no obtrusive maintenance actions are required at present.
- Level 2: “Alert” means parameter levels are unacceptable and repair actions are required at the next maintenance opportunity.
- Level 3: “Danger” parameter levels are dangerously high and urgent repair actions are required, serious damage may be occurring.

Figure 37 illustrates what CMS is trying to achieve with wear debris measurement. The figure of 90% wear is arbitrary for illustration purposes only. The aim will be to allow the WT to operate as close as practicable to 100% wear without risking catastrophic failure.

**Figure 36: Schematic of Routine v Arbitrary v Optimised Maintenance Systems**

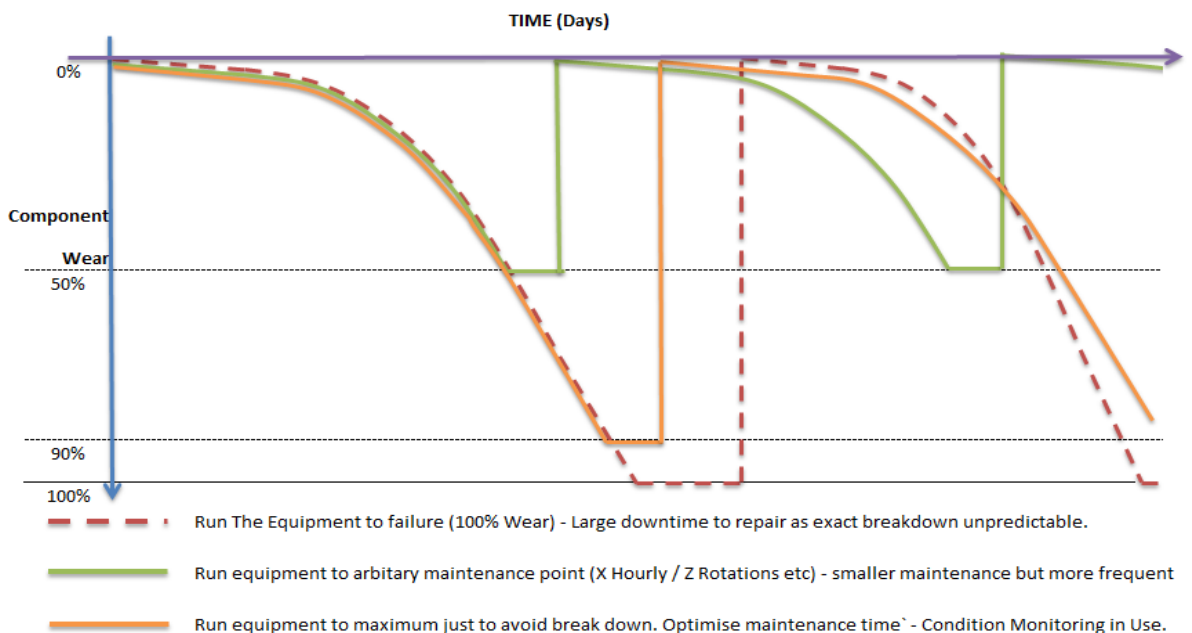

Another requirement within CMS is the derivation of algorithms for sub-systems or individual items of equipment that can be used to monitor performance and predict failures in advance. Such automation is still in its infancy and can be difficult to develop as WT manufacturers are not ready to release performance and operational data for their products as it may interfere with their warranty liabilities. However, as operators are now demanding greater WT reliability this information is becoming more forth-coming.

An exciting example of such automation is based on the work of a Durham University researcher which is able to create a “*Finger print*” for a WT Electric Pitch System [40]. Figures 38, 39, and 40 illustrate the change in the “*Finger print*” due to the effect of O&M. The Pitch Motor torque was plotted against 10 minute

mean wind speed and power output. The three paired sets of the Pitch Motor output for two blades on the same WT show that, although they are similar between WTs they are almost identical for the same WT. What is also noticeable is the shift in “shape” of the characteristic before and after maintenance. Observing changes in these “finger prints” for individual turbines may be a good tool for optimising planning of maintenance or imminent failure of components.

For information in the diagrams the axis are as follows

Vertical:                    The ten minute mean power output in KW

Left Horizontal:        The ten minute mean wind speed in metres per second

Right Horizontal:      The ten minute mean motor torque in Newton metres

Note that the WTs are of an identical model all located in a single wind farm but are not Liberty Turbines.

Figure 37: “Finger Prints” of blade pairs for WT 1087 (Courtesy J Moore [40])

WT 1087. Blade 1 is the left plot. Blade two is the right plot. The dark blue dots are after O&M the light blue dots are before O&M.

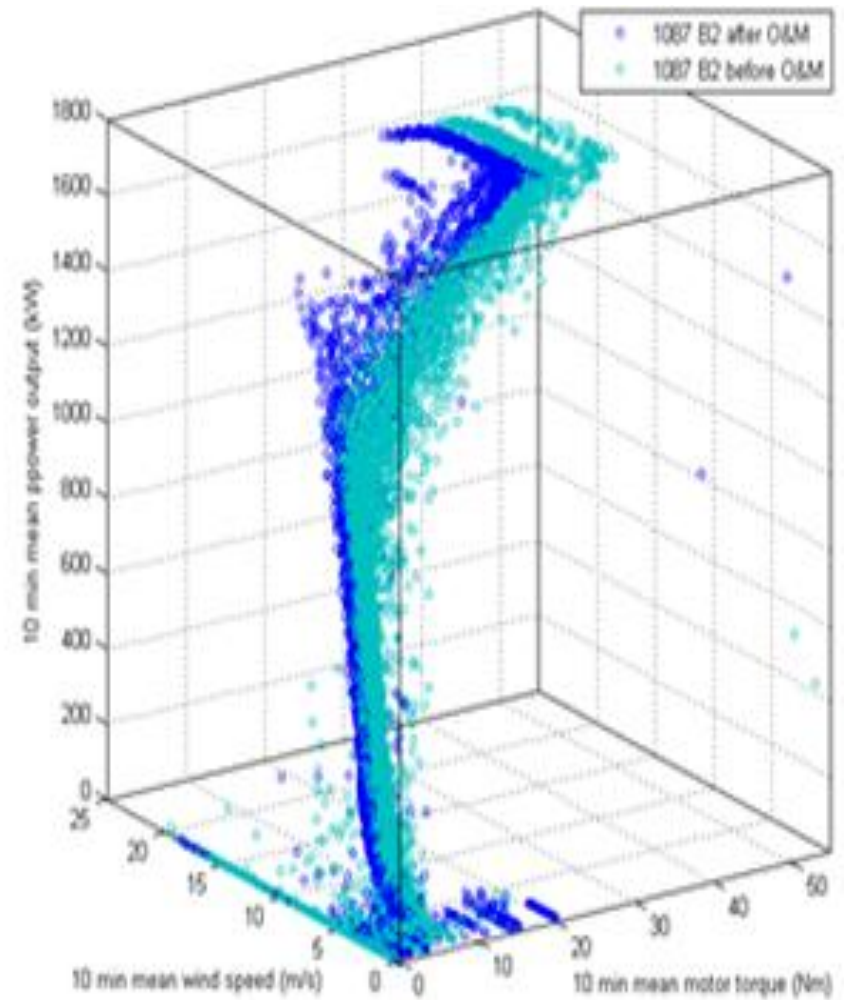
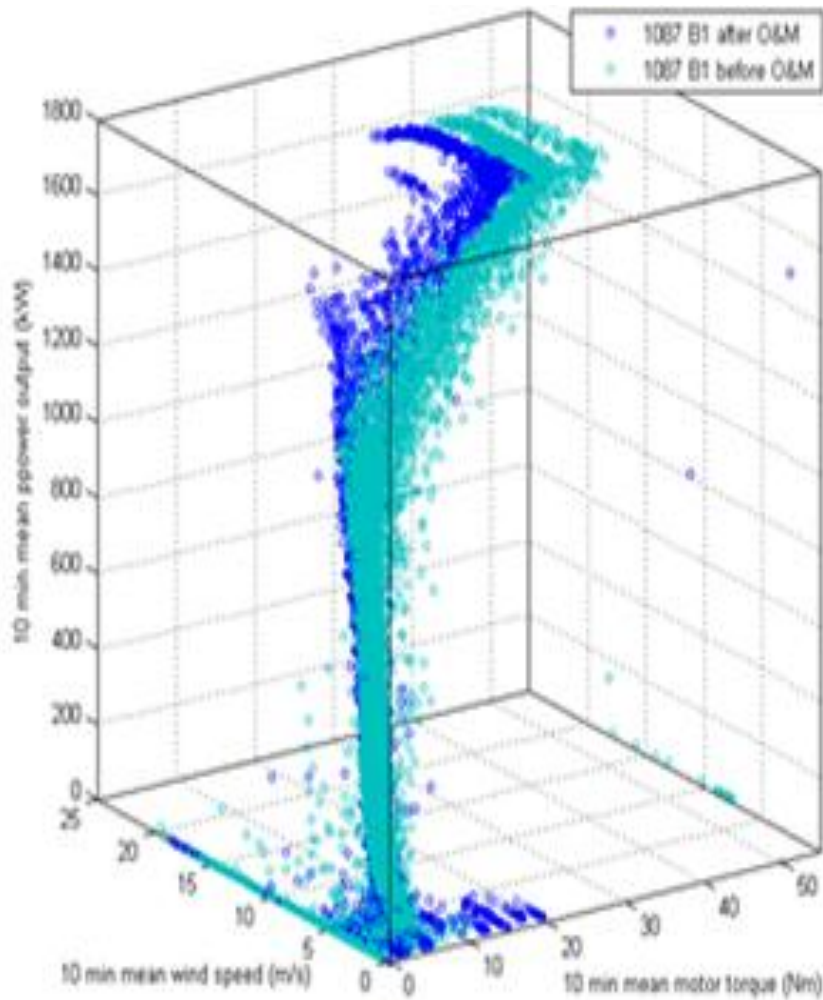

Figure 39: “Finger Prints” of blade pairs for WT 1082 (Courtesy J Moore [40])

WT 1082. Blade 1 is the left plot. Blade two is the right plot. The Purple dots are after O&M the light blue dots are before O&M

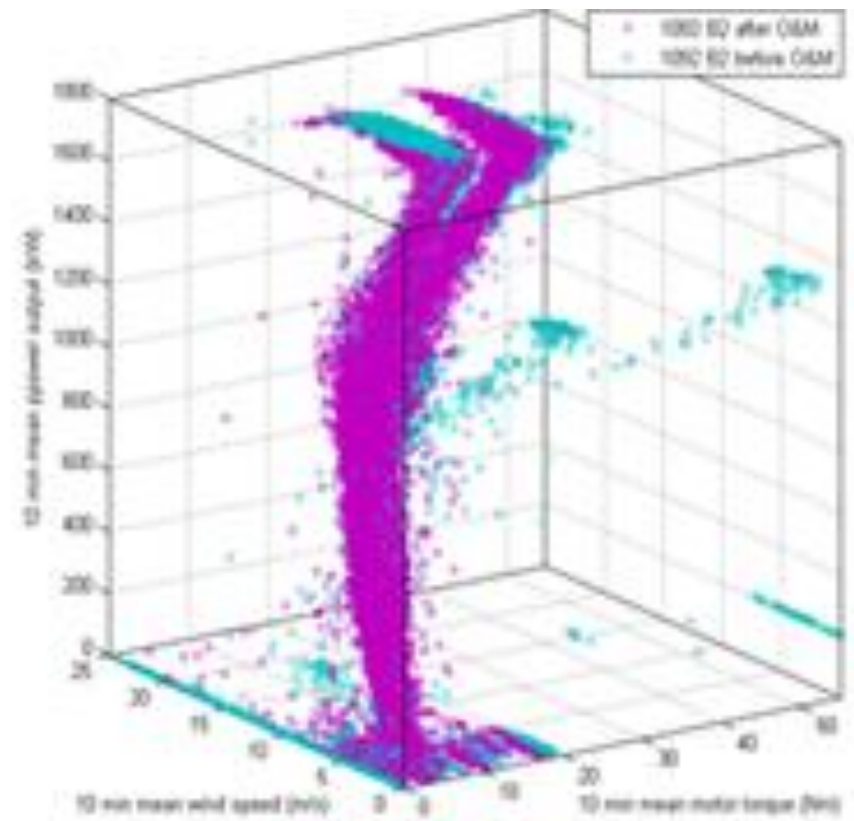
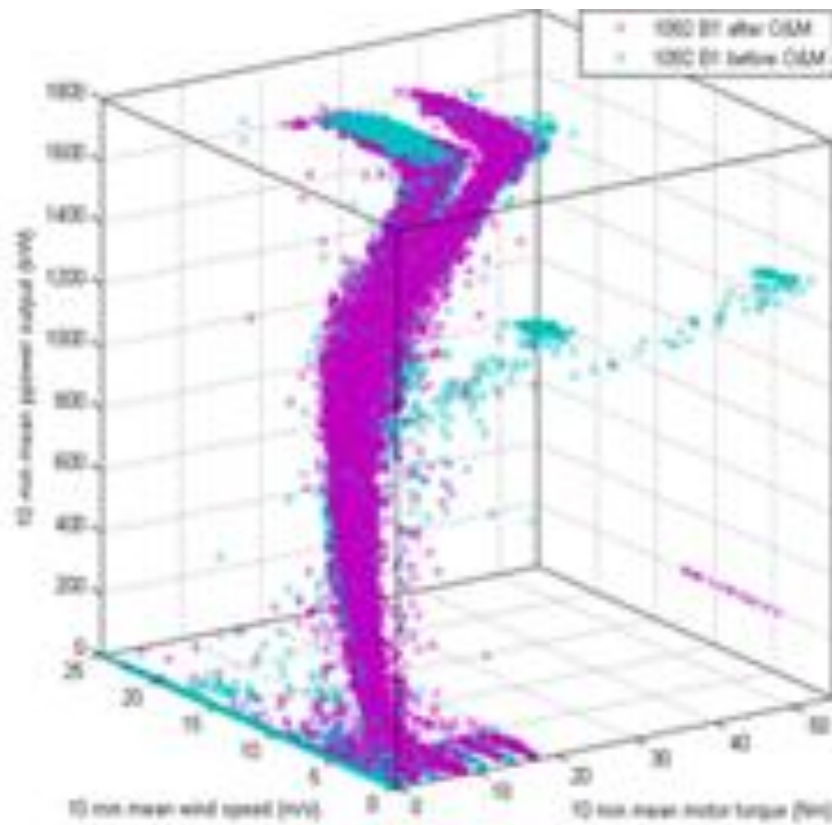
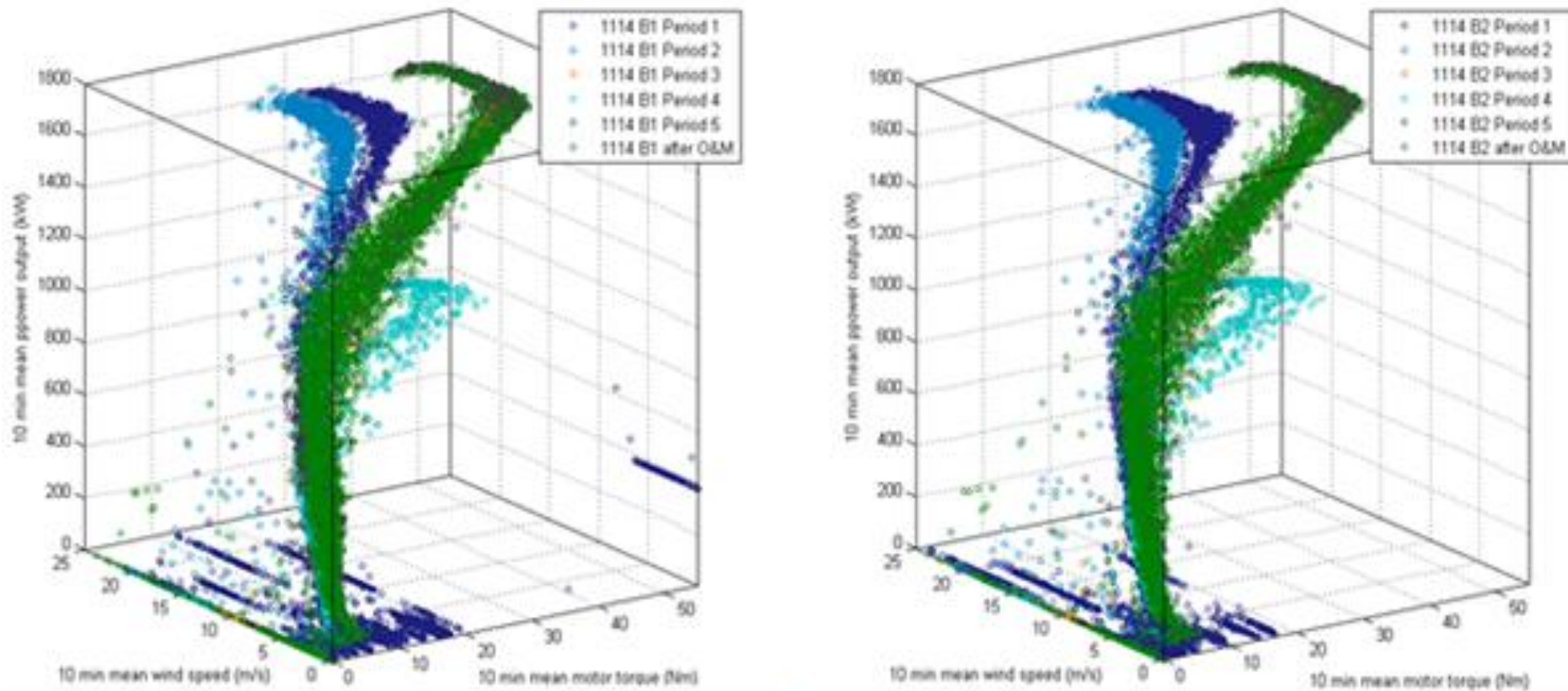



Figure 40: “Finger Prints” of blade pairs for WT 1114 (Courtesy J Moore [40])

WT 1114. Blade 1 is the left plot. Blade two is the right plot. The Green dots are after O&M the other dots are plots before O&M for set time periods and various wind conditions.



## **8 Conclusions and Further Work**

This research set out to examine the factors impacting on the availability, reliability and maintainability of offshore WTs. More specifically it has used the reliability data of Clipper Windpower's onshore 2.5 MW Liberty machine as the practical evidence for doing so. The primary aim in analysing this data was to build a picture of typical fault type and duration and more specifically alarm type, distribution and alarm quantity. These results were then compared with ReliaWind data to identify common trends or major divergences. The findings used to identify potential improvements in availability, reliability and maintainability for the design of Clipper Windpower's offshore Britannia 10 MW machine.

Onshore windfarms currently have availability levels of 96-98% which means that reasonable costs of energy are achievable. For an offshore windfarm availability levels must be 98% or greater for reasonable cost of energy. To achieve 98% availability offshore failure rates need to be reduced by a minimum of 25% and ideally 45%. One of the main contributors to these failure rates currently is alarms that cannot be remotely reset and requires the manual intervention of a maintainer. Unique analysis in this thesis has shown that 76.5% of the total alarms in a WT cannot be remotely reset and require intervention by maintainers. Such intervention is easily achievable at low cost on a daily basis for an onshore windfarm. Offshore such interventions cost 8 to 25 times more, on access costs alone and often apply to single turbines and not a whole windfarm. In addition offshore farms may not be accessible for 15% or more of the year due to weather. Minimising the total number of alarms or reducing the alarm severity as far as possible without risking WT catastrophic failure will go a long way in achieving the 25-45% reduction in failure rates. This can be done for an initial fixed cost resulting in long term improvement in overall availability, achieving the desired cost of energy.

## 8.1 Conclusions

The key conclusions from this research are outlined below.

The number and classification of alarms built into the whole system needs to be critically reviewed with the aim of reducing and rationalising responses where possible. This is critical for reducing the number of “false alarms” and overall interventions required particularly for the offshore WT where there are the associated difficulties of access.

- The pitch system for Liberty and especially the Britannia WT will need to be dramatically improved and requires further detailed investigation and redesign/design. This is required as the pitch system contributes the most faults and lost time for the WT. The part solution for the Britannia is to replace the EPU SLB with ultracapacitors as this is economical for offshore scenarios. For the onshore Liberty WT the use of ultracapacitors is likely to be uneconomic. Another viable means of improving performance would be to move the EPU into the Nacelle. Both WTs could benefit from the use of forward-looking laser technology to improve pitch and yaw response to the wind and reduce stresses on the pitch and yaw systems.
- The ability to access the wind farms quickly and cost effectively will be critical to maintaining the required levels of WT availability. This will be especially critical for future true offshore fields which involve there are much greater distances from shore than the current near shore fields.
- Britannia WT needs to be designed for reliability and availability not just for keeping the WT in a safe mode. Reliability maximisation is critical for reducing the number of interventions and associated difficulties of access to a minimum. Availability maximisation is critical for reducing the overall cost of energy. This includes but is not limited to reviewing and redesigning the pitch system, critically reviewing the SCADA alarm architecture and accessibility issues such as foundation design.

- Currently performance operational and maintenance records are held in different formats in different locations. These need to be brought together in some form of central data pool. This data pool could then be more easily interrogated for a number of purposes, including failure modes, downtime allocation, and performance data.

## **8.2 Future research**

It is suggested that in order to improve understanding of the issues highlighted above that further research includes but is not limited to the following areas:

- Critically review alarms with respect to the overall numbers. Explore how individual alarms could be grouped to provide better clarity of what the root cause is. Limit the severity level and required response as far as possible. The benefit of this work would be to help reduce the number of interventions required to the absolute minimum necessary based on alarm signals.
- Currently the electric pitch system is the biggest contributor to faulting and lost availability of the WT. Therefore it is important to investigate methods to improve the reliability of the electric pitch system in the Britannia WT. This could involve: replacement of the batteries with ultracapacitors; risk assessing the implications of repositioning the EPU in the nacelle and improving the response time of individual blades to actual wind conditions.
- Develop and better understand predictive algorithms for use in the condition monitoring of the sub-system or specific items of equipment to assist in condition monitoring of the WT. This would enable proactive prediction of failures and hence improved planning of maintenance and maintenance scheduling to prevent total failure.
- “Finger print” the planned prototype Britannia test WT to validate and assess whether these techniques will be effective in service. As with the previous point this may help to improve the proactive prevention of failures.
- Assess the relative benefits and costs of the various offshore access methods that exist and recommend individual methods or combination of methods to improve offshore accessibility. Access will be ever more critical as the wind farms increase in size, complexity and distance from shore.

- Creation of a central database to hold the full life cycle and operational data for a WT is important. Currently data is held in a variety of formats and stored in many separate locations under different ownership. A central data base would improve the ability to access historical data of all forms to be able to better analyse it in detail.

## Appendix A: Liberty v Britannia Specifications

**A1: Proposed Britannia WT specification compared with Liberty WT specifications**

	<b>BRITANNIA (Proposed)</b>	<b>LIBERTY</b>			
Model	C150	C89	C93	C96	C100
Power Output (kW)	10,000	2500	2500	2500	2500
Wind Class	la*	la*	IIa	IIb	IIIb
Operation (rpm)	6.05 - 11.5	9.6 - 15.5			
Rotor Diameter (m)	150	89	93	96	100
Swept Area (m <sup>2</sup> )	17672	6221	6793	7238	7854
Blades (m)	71.5	43.2	45.2	46.7	48.7
Cut in (m/s - 10min ave)	4	4	4	4	4
Cut out (m/s - 10min ave)	25	25	25	25	25
Pitch System	3x Electric-Mechanical Gearmotor Servo Drives with Capacitor Back-up	3x Electric-Mechanical Gearmotor Servo Drives with Capacitor Back-up			
<b>GENERATOR</b>					
Type	Synchronous Permanent Magnet	Synchronous Permanent Magnet			
Rated Power Each (kW@rpm)	2600 @ 2270	660 @ 1133			
Number of Units	4	4			
Voltage (VAC-VDC at rated power)	3600	1320			
<b>CONTROLLER</b>					
Type	Embedded Motorola Power PC	Embedded Motorola Power PC			
Voltage	3 Phase 400VAC 50Hz	3 Phase 400VAC 50Hz			
<b>POWER CONVERTER</b>					
Type	4x Voltage Source converters with IGBT bridges 6 Pulse Inverter Bridges	4x Voltage Source converters with IGBT bridges 6 Pulse Inverter Bridges			
Voltage	2400 VAC 50/60Hz	2400 VAC 50/60Hz			
<b>YAW SYSTEM</b>					
Yaw Drive	4 Electro-Mech Motors & Planetary Drives	4 Electro-Mech Motors & Planetary Drives			
Yaw Bearing	External Gear - Ball Bearing	External Gear - Ball Bearing			
Yaw Brake System	Disc Active Hydraulic Brake Calipers	Disc Active Hydraulic Brake Calipers			
<b>BRAKE</b>					
Parking Brake System	Disc Active Hydraulic Brake Calipers	Disc Active Hydraulic Brake Calipers			
Parking Brake Location	Intermediate Stage of Gearbox	Intermediate Stage of Gearbox			
<b>MAINTENANCE</b>					
Post Commissioning	700hrs	700hrs			
Routine Planned	6 Months	6 Months			

\*Class Ia - All parameters are the same as IEC Class Ia except 50-Year return gust value is 64.5m/s instead of 70m/s

**A2: Comparative size of Nacelles for the Liberty WT (Top) and the Britannia WT (Bottom) to scale.**

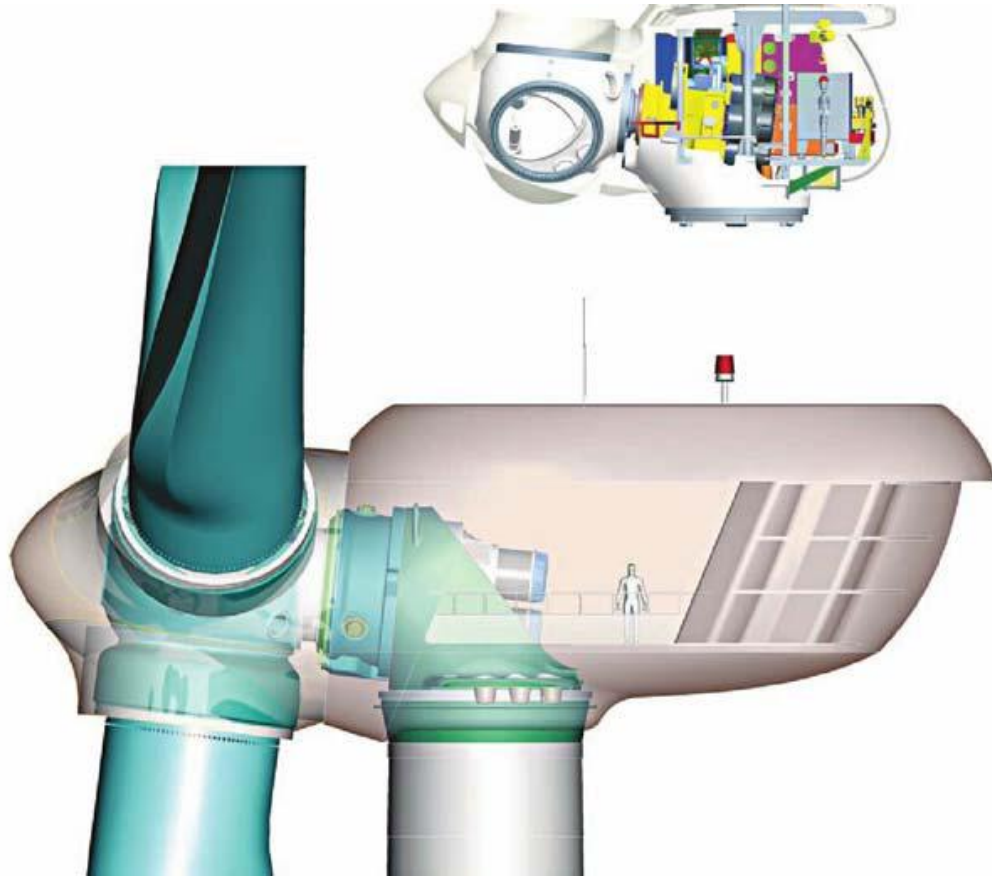

**A3: Comparative size of the two WT's compared with well known geographical features.**

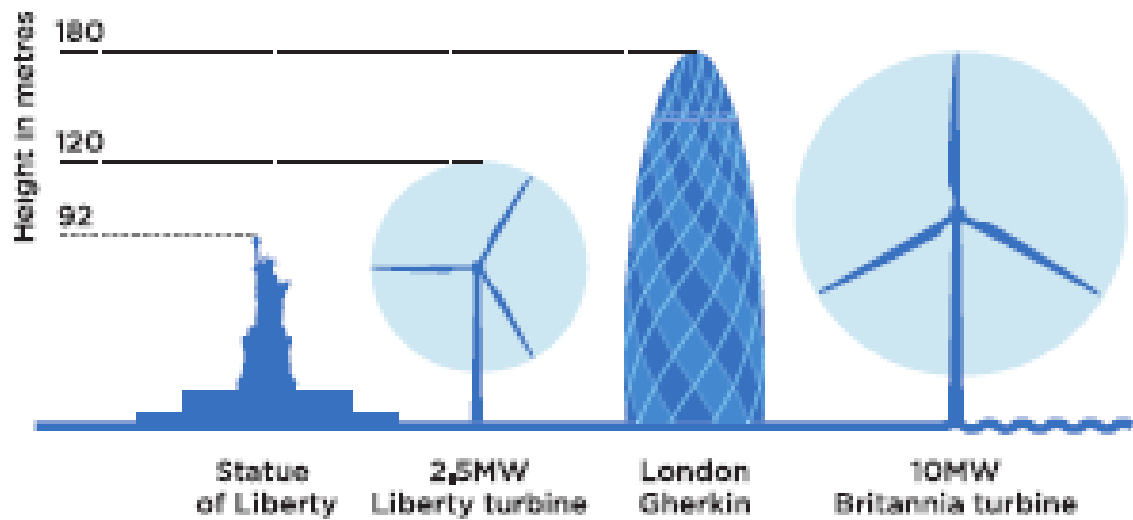

Appendix B 1: Figure B Structure for the research developed by the author

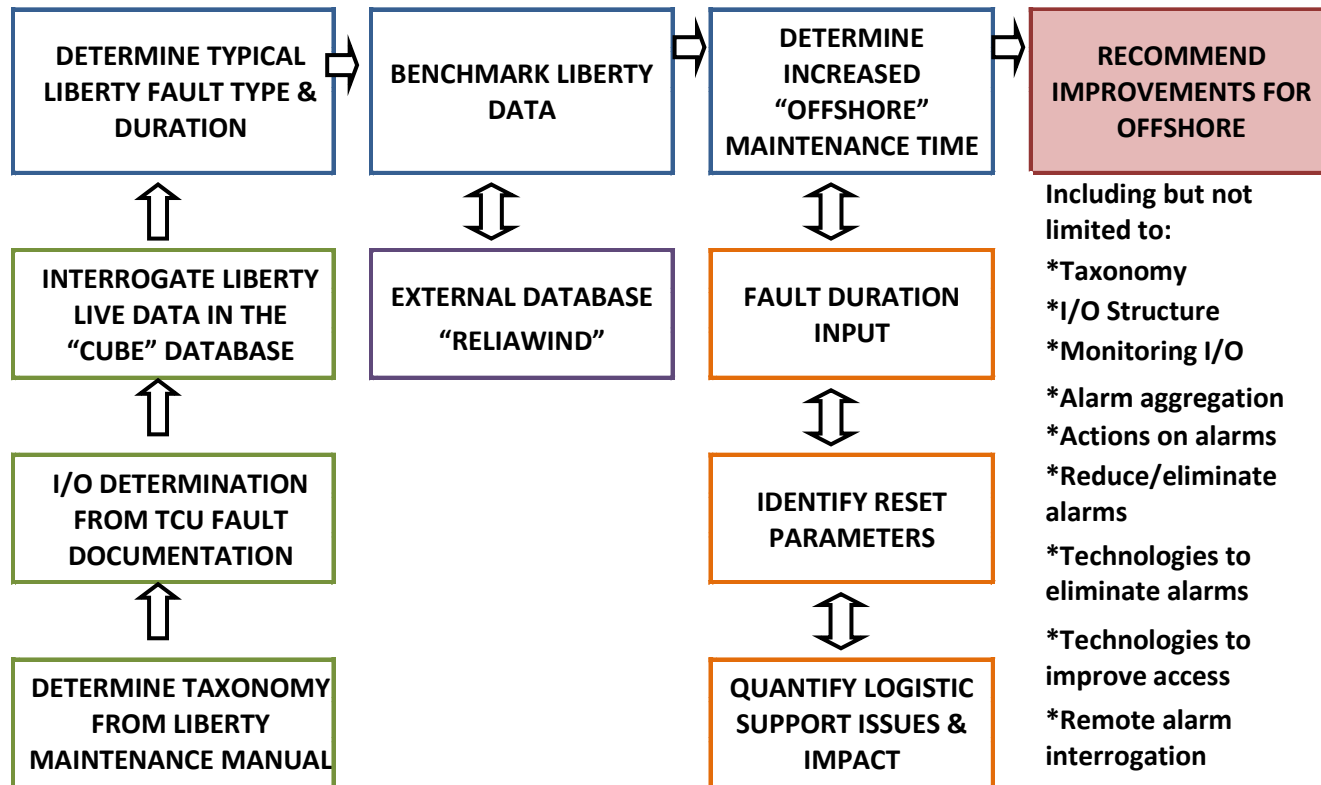



## References

### Clipper Windpower Internal References

- A. Yarala R., (2009) "2.5 MW "Clipper Wind Turbine" product Specification and Codes. DC-013559-01 Rev C. Clipper Windpower, Unpublished
- B. Gardener M., (2009) TCU Fault, Control Logic and Sensor Tables DC-009309-01 Rev C. Clipper Windpower, Unpublished
- C. Gardener M., (2009) TCU Control Logic and I/O Description DC-009308-01 Rev C. Clipper Windpower, Unpublished
- D. Danker A., (2009) SCADA Specification (Application) DC-005788-01 Rev D. Clipper Windpower, Unpublished
- E. Gardener M., (2009) TCU Control Logic and I/O Description DC-009308-01 Rev C. Clipper Windpower, Unpublished
- F. Datastay Database., (2009) Fault Trouble Shooting Guidelines. Clipper Windpower, Unpublished
- G "CUBE" Database., (2009) Computer based SCADA data Storage and interrogation system. Clipper Windpower, Unpublished

### External References

1. Uslu A et al (2009) *Europe's onshore and offshore wind energy potential - An assessment of environmental and economic constraints* [Online] European Environment Agency. Office for Official Publications of the European Communities. Available from <http://www.eea.europa.eu/publications/europes-onshore-and-offshore-wind-energy-potential> [Accessed 10 October 2009] DOI 10.2800/11373
2. Azau S, Rose C, Fichaux N, Wilkes J. (2009) *Oceans of Opportunity - Harnessing Europe's largest domestic energy resource* [Online] Belgium. European Wind Energy Association. Available from [http://www.ewea.org/fileadmin/ewea\\_documents/documents/publications/reports/Offshore\\_Report\\_2009.pdf](http://www.ewea.org/fileadmin/ewea_documents/documents/publications/reports/Offshore_Report_2009.pdf) [Accessed 1 November 2009]
3. Van Bussel GJW, Henderson AR, Morgan CA, Smith B, Barthelmie R, Argyriadis K, Arena A, Niklasson G, Peltola E. (2001) *State of the Art and Technology Trends for Offshore Wind Energy: Operation and Maintenance Issues* [Online] Delft University of Technology. European Commission. Available from [http://www.tudelft.nl/live/pagina.jsp?id=3dcbe092-4334-4d47-9f82-dff9ed15ab5e&lang=en&binary=/doc/owec2001\\_ca.pdf](http://www.tudelft.nl/live/pagina.jsp?id=3dcbe092-4334-4d47-9f82-dff9ed15ab5e&lang=en&binary=/doc/owec2001_ca.pdf) [Accessed 12 October 2009]

4. The Crown Estate. (2010). *Offshore Wind Energy History*. [Online]. October 2010. Available from: [http://www.thecrownestate.co.uk/newscontent/offshore\\_wind\\_energy](http://www.thecrownestate.co.uk/newscontent/offshore_wind_energy). [Accessed: 1st October May 2010]
5. The Crown Estate. (2010). *The Crown Estate Announces R3 Offshore Wind Development Partners*. [Online]. March 2010. Available from: [www.thecrownestate.co.uk/newscontent/round3](http://www.thecrownestate.co.uk/newscontent/round3). [Accessed: 30th March 2010]
6. Van Bussel G J W, Zaaijer M B. (2001) *DOWEC Concepts Study, Reliability, Availability And Maintenance Aspects*. European Wind Energy Conference. Copenhagen, Monday 2<sup>nd</sup> to Friday 6<sup>th</sup> July 2001 Copenhagen
7. Fichaux N, Wilkes J. (2009) *Oceans of Opportunity - Harnessing Europe's largest domestic energy resource* [Online] European Wind Energy Association. Available from [http://www.ewea.org/fileadmin/ewea\\_documents/documents/publications/reports/Offshore\\_Report\\_2009.pdf](http://www.ewea.org/fileadmin/ewea_documents/documents/publications/reports/Offshore_Report_2009.pdf) [Accessed 14 October 2009]
8. Tavner P J, Xiang J, Spinato F. (2007) *Reliability Analysis for Wind Turbines* Wind Energy. 10: p1-18 DOI 10.1002/we.204
9. Spinato F, Tavner P J, Van Bussel G J W, Koutoulakos E. (2009) *Reliability of wind turbine subassemblies*. IET Renewable Power Generation. 3 (4) p 387-401. DOI 10.1049/iet-rpg.2008.0060
10. Gray C S, Watson S J. (2009) *Physics of Failure Approach to Wind Turbine Condition Based Maintenance*. Wind Energy. 13: p395–405 DOI 10.1002/we.360
11. Faulstich S, Hahn B, Jung H, Rafik K, Ringhandt A. (2008) *Appropriate failure statistics and reliability characteristics*. DEWEK Conference. Bremen, Wednesday 26<sup>th</sup> to Thursday 27<sup>th</sup> July 2008 Bremen.
12. British Wind Energy Association. (2009) *UK Offshore Wind: Charting the Right Course Scenarios for offshore capital costs for the next five years* [Online] British Wind Energy Association. Available from <http://www.bwea.com/pdf/publications/ChartingtheRightCourse.pdf> [Accessed 24 October 2009]
13. Higgins, A. (2010). *Development of the Failure Modes and Effects Analysis Method for Onshore and Offshore Wind Turbines*. A Dissertation Submitted in partial fulfilment of the Requirements of Durham University for the Degree of Master of Engineering. Durham: Durham University.

14. Kühn M, Bierbooms WAAM, Van Bussel GJW, Ferguson MC, Göransson B, Cockerill TT, *et al.* (1997) *Structural and Economic Optimisation of Bottom-Mounted Offshore Wind Energy Converters*. Delft University of Technology. European Commission. ISBN 90-76468-01-X
15. Nilsson J, Bertling L. (2007) *Maintenance management of wind power systems using condition monitoring systems - Life cycle cost analysis for two case studies..* IEEE Transactions on Energy Conversion. 22 (1): p 223-229 DOI 10.1109/Tec.2006.889623
16. Van Bussel GJW, Schöntag C. (1997) *Operation and Maintenance Aspects of Large Offshore Windfarms*. [Online] Delft University of Technology. European Commission. Available from <http://www.ewi.tudelft.nl/live/binaries/3dcbe092-4334-4d47-9f82-dff9ed15ab5e/doc/EWEC97new.pdf>. [Accessed 22 October 2009]
17. Bierbooms WAAM, Van Bussel GJW. (2003) *The impact of different means of transport on the operation and maintenance strategy for offshore wind farms* [Online] Delft University of Technology. DOWEC project. Available from [http://administration.ewi.tudelft.nl/live/binaries/3dcbe092-4334-4d47-9f82-dff9ed15ab5e/doc/OWEMES2003\\_GvB.pdf](http://administration.ewi.tudelft.nl/live/binaries/3dcbe092-4334-4d47-9f82-dff9ed15ab5e/doc/OWEMES2003_GvB.pdf) . [Accessed 26 October 2009]
18. Offshore Access Systems BV. (2010). *Offshore Access System* [Online]. March 2010. Available from: <http://www.offshore-solutions.nl>. [Accessed: 19th March 2010]
19. Wiggelinkhuizen E, Verbruggen T, Braam H, Rademakers L, Xiang J, Watson S. (2008). *Assessment of Condition Monitoring Techniques for Offshore Wind Farms*. Journal of Solar Energy Engineering. 130 (3): p 1004-1-1004-9 DOI 10.1115/1.2931512.
20. Harman KD, Raftery PG. (2003) *Analytical Techniques For Understanding The Performance Of Operational Wind Farms*. European Wind Energy Conference. Madrid, Monday 16<sup>th</sup> to Thursday 19<sup>th</sup> June 2003 Madrid.
21. Yang W, Tavner PJ, Crabtree CJ, Wilkinson M. (2009) *Cost-Effective Condition Monitoring for Wind Turbines*. IEEE Transactions. 57 (1): p 263-271 DOI 10.1109/TIE.2009.2032202
22. Switzerland. International Electrotechnical Commission. (1999) *IEC PART 415: Wind Turbine Generator Systems*. Geneva. International Electrotechnical commission. (CEI / IEC 60050-415:1999)
23. Germany. Powertech VGB. (2007) *Reference designation system for power plants RDS-PP*. Essen. Powertech VGB. (VGB-B 116 D2)

24. Germany. Germanischer Lloyd.. (2007) *Guideline for the Certification of Condition Monitoring Systems for Wind Turbines*. Hamburg. Germanischer Lloyd Industrial Services.
25. Wilkinson M, Hendriks B, Spinato F, Gomez E, Bulacio H, Roca J, Tavner PJ, Feng Y, Long H. (2010) *Methodology and Results of the Reliawind Reliability Field Study*. European Wind Energy Conference. Warsaw, Tuesday 20<sup>th</sup> to Friday 23<sup>th</sup> April 2010 Warsaw.
26. Clarkson M. (2010). *The Rationalisation of Wind Turbine Reliability Data and Turbine Structure or Taxonomy to Assist in the Development of a Reliability-Centric Design for a Large 10MW Offshore Wind Turbine*. A Thesis Submitted in partial fulfilment of the Requirements of Durham University for the Degree of Master of Science. Durham: Durham University.
27. Wildcat Marine. (2010). *Windfarm transfer vessels in the Irish Sea*. [Online]. June 2010. Available from: <http://www.wildcat-marine.com>. [Accessed: 29th June 2010]
28. Maersk Supply Service. (2010). *Field And Subsea Support Vessels Craned A-Type* [Online]. June 2010. Available from: <http://www.maersksupplyservice.com/Fleet/FieldAndSubseaSupportVessels/Craned%20A-Type/Pages/MaerskAttender.aspx> [Accessed: 29th June 2010]
29. Ampelmann BV. (2010). *Ampelmann offshore Access System* [Online]. July 2010. Available from: <http://www.ampelmann.nl>. [Accessed: 14th July 2010]
30. Offshore Solutions BV. (2010). *Offshore Access System* [Online]. March 2010. Available from: <http://www.offshore-solutions.nl>.. [Accessed: 19th March 2010]
31. PTS –Personnel Transfer System GmbH. (2010). *Personnel Transfer System* [Online]. July 2010. Available from: <http://www.pts-offshore.com/en/aufgabe.htm>. [Accessed: 14th July 2010]
32. Momac GmbH. (2010). *Momac-Offshore-Access-Systems*. [Online]. July 2010. Available from: <http://www.momac.de>. [Accessed: 14th July 2010]
33. Harland & Wolff. (2001) *Offshore Wind transport and installation vessel*. Department of Trade and Industry. Crown Publishers. ETSU W/61/00570/rep
34. Payne J. (2009) *A ship operator/owner reponse to the subsea market - a design for beyond 2009*. OSJ Conference. London, Tuesday 24<sup>th</sup> to Wednesday 25<sup>th</sup> February 2009 London.
35. Metoffice. (2009). *Together - Work with us to plan, construct and maintain your renewable energy projects*. [Online]. July 2009. Available from: <http://www.metoffice.gov.uk/marine>. [Accessed: 14th July 2009]

36. Stiesdal H, Hauge-Madsen P. (2005) *Design For reliability*. Offshore Wind Conference. Copenhagen, day 26<sup>th</sup> to day 28<sup>th</sup> October 2005 Copenhagen.
37. Feng Y, Tavner PJ, Long H. (2010) *Early experiences with UK round 1 offshore wind farms*. Proceedings of the Institution of Civil Engineers. 163 (1): p 1-15 DOI 10.1680/ener.2010.163.0.1
38. Schneuwly A. (2009) *Ultracapacitors Improve Reliability For Wind Turbine Pitch Systems*. Maxwell Technologies Inc. [Online]. July 2009. Available from: <http://www.maxwell.com> [Accessed: 14th September 2010]
39. Arabian-Hoseynabadi H, Oraee H, Tavner P.J. (2010) *Failure Modes and Effects Analysis (FMEA) for wind turbines* Electrical Power and Energy Systems. 32 (7): p 817-824 DOI 10.1016/j.ijepes.2010.01.019
40. Moore J. (2010). *Analysis of SCADA Data from Large Wind Farms to Provide Incipient Fault Detection (MLS)*. A Thesis Submitted in partial fulfilment of the Requirements of Durham University for the Degree of Master of Science. Durham: Durham University.