



Durham E-Theses

The Basis of Freezing Tolerance Between and Within Species Across Environmental Gradients with a Focus on Arctic, Alpine and Moorland Plants

ROWLAND, ALICE,VICTORIA

How to cite:

ROWLAND, ALICE,VICTORIA (2019) *The Basis of Freezing Tolerance Between and Within Species Across Environmental Gradients with a Focus on Arctic, Alpine and Moorland Plants*, Durham theses, Durham University. Available at Durham E-Theses Online: <http://etheses.dur.ac.uk/13128/>

Use policy

The full-text may be used and/or reproduced, and given to third parties in any format or medium, without prior permission or charge, for personal research or study, educational, or not-for-profit purposes provided that:

- a full bibliographic reference is made to the original source
- a [link](#) is made to the metadata record in Durham E-Theses
- the full-text is not changed in any way

The full-text must not be sold in any format or medium without the formal permission of the copyright holders.

Please consult the [full Durham E-Theses policy](#) for further details.

The Basis of Freezing Tolerance
Between and Within Species
Across Environmental Gradients
with a Focus on Arctic, Alpine and
Moorland Plants

Alice Victoria Rowland



Department of Biosciences

Submitted for the Degree of Doctor of Philosophy by Research

January 2019

Abstract

Freezing events have devastating impacts on crops around the world. Climate change is resulting in more extreme freezing events as well as an increase in winter warm periods and shorter winters which can alter the process of acclimation and deacclimation leading to greater freezing susceptibility. Genes involved in freezing tolerance therefore need to be targeted by crop breeders to improve crop resistance to these events. The *CBF* family is one of these potential targets due to their presence across the Spermatophyta, including crop species, and their role in acclimation as transcription factors which activate cold response (*COR*) genes, thereby increasing freezing tolerance. Plants adapted to environments with frequent and very low temperature freezing events, such as arctic and alpine locations may, therefore, already possess modifications to these genes which improve freezing tolerance. The ability of native, dominant cover species to endure and adapt to these climatic changes can also be investigated via the study of variation within *CBF* over a species range.

CBF sequences were isolated from numerous arctic and alpine species. Several common polymorphisms in key *CBF* regions were identified and applied to *Arabidopsis thaliana CBF1*. The effect upon freezing tolerance and CRT/DRE activation of these modified *A. thaliana CBF1* sequences were then tested. No definitive conclusions could be drawn, however potential routes of further investigation are highlighted and discussed.

CBF sequences of *Empetrum nigrum* samples from a wide distribution and both high and low altitude were compared, no differences between sequences which correlated with sample location, were found. However preliminary expression studies indicated a difference in the kinetics of *CBF* expression between samples from different locations. Further study of *CBF* expression kinetics within this species is highly recommended.

Routes of further exploration leading to potential targets for crops are discussed, alongside suggested routes of further investigation for *Empetrum nigrum* and *Calluna vulgaris*.

Table of Contents

Abstract	i
Table of Contents	ii
List of Tables and Figures	viii
List of Abbreviations	x
Acknowledgements.	xiv
Chapter 1: Introduction	1
1.1 General Background.....	1
1.1.1 Freezing.....	1
1.1.2 Acclimation	2
1.2 The Effect of Climate Change.....	4
1.2.1 The Effect of Climate Change upon Acclimation and Native Plants	4
1.2.2 The Effect of Climate Change upon Crops	6
1.3 Potential Gene Sources For use in Crops	7
1.4 C-Repeat Binding Factor (CBF)	8
1.4.1 The Importance of CBF in Cold Acclimation and Freezing Tolerance	8
1.4.2 Key Domains within the CBF Protein	10
1.5 Scope of the Thesis	11
1.5.1 Thesis Aims & Rationales	12
Chapter Two: Materials and Methods	16
2.1 Sample Collection	16
2.1.1 Collection	16
2.1.2 Transport and Storage	17
2.1.3 Identification.....	17
2.1.4 Soil pH Calculation	18

2.2 Live Test Species Selection and Growth Conditions	43
2.2.1 Selection and Growth of Alpine Model Plants.....	43
2.2.1.1 Selection Criteria.....	43
2.2.1.2 Germination and Growth Media.....	44
2.2.1.3 Germination Conditions.....	44
2.2.1.4 Growth Conditions of Seedlings.....	45
2.2.2 Growth of <i>Empetrum nigrum</i> and <i>Calluna vulgaris</i> From Cuttings	45
2.2.2.1 Conditions	45
2.2.2.2 Rooting of Cuttings	46
2.2.3 <i>Nicotiana benthamiana</i> Growth Conditions	47
2.2.4 Growth of <i>Arabidopsis thaliana</i>	47
2.2.4.1 MS Media	47
2.2.4.2 Seed Sterilisation	48
2.2.4.3 Germination and Growth.....	48
2.2.4.4 GA ₃ stock for topical application	49
2.3 Freezing and Chilling Treatments for Live Samples	49
2.3.1 <i>Empetrum nigrum</i> Chilling Time-course for qPCR	49
2.3.2 <i>Arabidopsis thaliana</i> Visual Freezing Assay	52
2.4 Measuring Indicators of Plant Health	52
2.4.1 Chlorophyll Content.....	52
2.4.1.1 Freezing Tests for Chlorophyll Extractions.....	52
2.4.1.2 Chlorophyll Extraction.....	53
2.5 Primers & Gene Blocks.....	54
2.5.1 Primer Design.....	54
2.5.1.1 Standard Primers	62
2.5.1.2 Primers for Cloning	68
2.5.1.3 Primers for qPCR.....	68
2.5.2 Synthetic Gene Design	68
2.5.3 Primer Sequences	70
2.6 DNA and RNA Extraction.....	70
2.6.1 DNA Extraction.....	70
2.6.1.1 Edwards Extraction	70
2.6.1.2 Powerplant® Pro DNA Isolation	71
2.6.2 RNA Extraction	72
2.6.2.1 RNA Extraction from <i>Arabidopsis thaliana</i>	72

2.6.2.2 RNA Extraction from <i>Empetrum nigrum</i>	72
2.6.3 cDNA Synthesis	73
2.7 PCR Amplification and Product Purification	74
2.7.1 PCR Amplification.....	74
2.7.1.1 PCR Mixes.....	74
PCR mix 1.....	74
PCR mix 2.....	74
MYTAQ PCR	75
2.7.1.2 PCR Conditions.....	75
PCR1-3	75
PCR 4 (KAPA3G).....	76
MY TAQ PCR	76
2.7.2 Gels.....	76
2.7.2.1 TBE Gels.....	76
2.7.2.2 Imaging Gels.....	77
2.7.3 PCR Product Purification	77
2.7.3.1 Gel Extraction.....	77
2.7.3.2 Direct From Product Band Extraction	79
2.7.4 Sequencing and Analysis of Sequence Results.....	79
2.7.4.1 Quality Control and Cleaning of Sequences.....	79
2.7.4.2 Protein Translation and Comparison	80
2.7.5 Quantitative PCR	80
2.8 Cloning	81
2.8.1 Media	81
LB agar.....	81
LB.....	81
2.8.2 Selection of <i>Escherichia coli</i> Containing the pEntr-D-TOPO Vector.....	81
2.8.3 Plasmid Extraction.....	82
2.8.4 Digestion	83
Plasmid Digestion.....	83
Insert Digestion	83
2.8.5 Ligation.....	83
2.8.6 Transformation Into <i>Escherichia coli</i>	84
2.8.7 Gibson Assembly and Transformation of Gene Blocks	84
2.8.8 Transformation into <i>Agrobacterium tumefaciens</i>	86

2.8.9 Plasmid Quality Control	86
2.8.10 Transient Expression by Infiltration in <i>Nicotiana benthamiana</i>	86
2.8.11 Stable Transformation of <i>Arabidopsis thaliana</i>	88
2.8.12 Stocks and Storage	89
2.8.12.1 Glycerol Stocks	89
2.9 Phenotypic Scoring.....	89

Chapter 3: Isolating and Analysing C-Repeat Binding Factor

(CBF) Sequences from Arctic, Alpine and Moorland Plant

Species 91

3.1 Results.....	92
3.1.1 CBF Nucleotide Sequences.....	92
3.1.1.1 Brassicaceae	92
3.1.1.2 Ericaceae	96
3.1.1.3 All Other Species	99
3.1.2 Translated CBF sequences	104
3.1.2.1 CBF Signature Sequences and the AP2 Domain.....	109
3.1.2.1.1 Differences Between <i>Arabidopsis thaliana</i> CBF1-4 AP2 and CBF Signature Sequences, and Comparison to All Other Sequences.....	109
3.1.2.1.2 The AP2 Domain.....	109
3.1.2.1.3 The N terminus CBF signature sequence	110
3.1.2.1.4 The C-Terminus CBF Flanking Sequence	110
3.1.3 MATK sequences.....	111
3.1.3.1 Collected vs NCBI Database <i>Calluna vulgaris</i> Sequences	116
3.2 Discussion.....	120
3.2.1 CBF Sequences	120
3.2.1.1 CBF Amplification	120
3.2.1.2 CBF Sequence Quality	121
3.2.1.3 CBF Nucleotide Sequences.....	123
3.2.1.3.1 Brassicaceae	123
3.2.1.3.2 Ericaceae	125
3.2.1.3.3 All Other Species	127
3.2.1.4 Translated CBF Sequences	129
3.2.1.4.1 Full CBF Sequence Comparisons	131

3.2.1.4.2 AP2 and CBF Signature Flanking Sequences	132
3.2.1.4.3 The C-Terminus CBF Flanking Sequence	135
3.2.2 MATK Sequences.....	137

Chapter 4: Introducing Mutations into *Arabidopsis thaliana*

CBF1 that Represent Common Polymorphisms Seen in Arctic and Alpine Plants and Testing for Effect upon Function 140

4.1 Results.....	141
4.1.1 Transient Expression of <i>CBF1</i> Mutations in <i>Nicotiana benthamiana</i>	141
4.1.2 Overexpression of <i>CBF1</i> Constructs in <i>Arabidopsis thaliana</i>	147
4.1.2.1 Establishment of Stable Transgenic <i>Arabidopsis thaliana</i> lines.....	147
4.1.2.2 Expression of <i>CBF1</i> and <i>COR</i> Genes in Transgenic <i>Arabidopsis thaliana</i> Lines.	150
4.1.2.3 Ability of Different <i>CBF1</i> Constructs to Activate <i>COR</i> Genes in Transgenic <i>Arabidopsis thaliana</i>	154
4.1.2.4 Ability of Transgenic <i>Arabidopsis thaliana</i> to Survive Freezing in Relation to the Degree of <i>CBF1</i> and <i>COR</i> Gene Expression	156
4.2 Discussion.....	170
4.2.1 Effect of <i>CBF1</i> Mutations Upon CRT/DRE Activation when Transiently Expressed in <i>Nicotiana benthamiana</i>	170
4.2.2 Effect of Stable Overexpression of <i>CBF1</i> Constructs in <i>Arabidopsis thaliana</i>	176
4.2.2.1 Establishment of Stable Transformed <i>Arabidopsis thaliana</i> Lines	176
4.2.2.2 Levels of <i>CBF</i> and <i>COR</i> Gene Expression in Stable Transformed <i>Arabidopsis thaliana</i> Lines	179
4.2.2.3 Effect of Freezing Upon Transformed <i>Arabidopsis thaliana</i> lines and The Relation to <i>CBF</i> and <i>COR</i> Gene Expression	183

Chapter 5: Natural Variation in *Empetrum nigrum* and

***Calluna vulgaris* from Differing Environments 187**

5.1 Results.....	188
5.1.1 Establishment of Arctic/Alpine Model Plants	188
5.1.2 <i>CBF</i> Sequence Comparison from <i>Empetrum nigrum</i> Plants from Differing Environments	188
5.1.3 <i>CBF</i> Expression in <i>Empetrum nigrum</i>	198

5.1.3.1 Identification, Design and Testing of Primers for use in qPCR on cDNA from <i>Empetrum nigrum</i>	198
5.1.3.2 Identification of the Optimal <i>Empetrum nigrum</i> cDNA Dilution for qPCR.....	200
5.1.3.3 Effect of chilling upon <i>CBF</i> Expression in <i>Empetrum nigrum</i>	201
5.1.3.4 Kinetics of <i>CBF</i> Expression in Response to Chilling in <i>Empetrum nigrum</i> Between Plants Originating From Different Environments	202
5.1.3.4.1 qPCR Amplification Irregularities	202
5.1.3.4.2 Results.....	205
5.1.4 Changes in Chlorophyll Content Of <i>Empetrum nigrum</i> and <i>Calluna vulgaris</i> in Response to Freezing	208
5.1.5 The Association of the Environmental Origin of the Parent Donor Plant with the Morphology of Common Garden Grown Cuttings of <i>Empetrum nigrum</i> and <i>Calluna vulgaris</i>	210
5.1.5.1 <i>Empetrum nigrum</i>	210
5.1.5.2 <i>Calluna vulgaris</i>	211
5.2 Discussion.....	218
5.2.1 Potential Model Plants.....	218
5.2.2 The <i>CBF</i> sequence of <i>Empetrum nigrum</i>	218
5.2.3 <i>CBF</i> expression in <i>Empetrum nigrum</i>	221
5.2.3.1 Suitability of Primers Designed for qPCR	221
5.2.3.2 Optimal dilution of <i>Empetrum nigrum</i> cDNA for qPCR.....	223
5.2.3.3 The Effect of Chilling upon <i>CBF</i> Expression in <i>Empetrum nigrum</i>	224
5.2.3.4 Kinetics of <i>CBF</i> Expression in Response to Chilling in <i>Empetrum nigrum</i> Between Plants Originating From Different Environments	226
5.2.3.4.1 Irregular Amplification	226
5.2.3.4.2 Kinetics of <i>CBF</i> Expression	228
5.2.4 The use of Chlorophyll Content to Assess Freezing Tolerance in <i>Empetrum nigrum</i> and <i>Calluna vulgaris</i>	234
5.2.4.1 <i>Calluna vulgaris</i>	234
5.2.4.2 <i>Empetrum nigrum</i>	237
5.2.5 The Association of the Environmental Origin of the Parent Donor Plant with the Morphology of Common Garden Grown Cuttings of <i>Empetrum nigrum</i> and <i>Calluna vulgaris</i>	240
5.2.6 A Note on <i>Empetrum nigrum</i> Subspecies	247
Chapter 6: General Discussion	251
Bibliography	258

List of Tables and Figures

Figure 1.1.2.1	3
Figure 1.4.2.1	11
Table 2.1.5.....	19
Figure 2.3.1.1.	51
Table 2.5.1.....	55-61
Figure 2.5.1.1	67
Table 2.5.2.1.....	69
Figure 2.8.7.1	85
Figure 3.1.1.1.1	94-95
Figure 3.1.2.2	108
Figure 3.1.3.1	113
Figure 3.1.3.1.1	117
Figure 4.1.1.1	143
Figure 4.1.1.2	144
Figure 4.1.1.3	145
Figure 4.1.1.4	146
Table 4.1.2.1.1.....	148
Table 4.1.2.1.2.....	149
Figure 4.2.1.1	175
Figure 5.1.2.1	190-195
Figure 5.2.1.2	196-197
Table 5.1.3.1.1.....	198
Figure 5.1.3.2.1	200
Figure 5.1.3.3.1	201

Figure 5.1.3.4.1.1	203
Figure 5.1.3.4.1.2	204
Figure 5.1.3.4.2.1	206
Figure 5.1.3.4.2.2	207
Figure 5.1.4.1	209
Table 5.1.5.3.1	212
Figure 5.1.3.2	213
Figure 5.1.3.3	214
Figure 5.1.3.4	215
Figure 5.1.3.5	216
Figure 5.1.3.6	217

List of Abbreviations

CBF – C-Repeat Binding Factor

COR – Cold Responsive

CRT/DRE – C-Repeat/Dehydration Response Element

EDTA - Ethylenediaminetetraacetic acid

ICE1 – Inducer of *CBF* Expression 1

LTI78 – Low Temperature Protein 78

MATK – Maturase K

PCR – Polymerase Chain Reaction

PEX4 – Peroxin 4

pp – Primer Pair

qPCR – Quantitative Polymerase Chain Reaction

TBE – Tris/Borate/EDTA

Nucleotides

A – Adenine

T – Thymine

C – Cytosine

G – Guanine

Amino Acids

A – Alanine

R – Arginine

N – Asparagine

D – Aspartic acid

C – Cysteine

E – Glutamic acid

Q – Glutamine

G – Glycine

H – Histidine

I – Isoleucine

L – Leucine

K – Lysine

M – Methionine

F – Phenylalanine

P – Proline

S – Serine

T – Threonine

W – Tryptophan

Y – Tyrosine

V – Valine

“I certify that all of the work described in this thesis is my own original research unless otherwise acknowledged in the text or by references, and has not been previously submitted for a degree in this or any other university”

“The copyright of this thesis rests with the author. No quotation from it should be published without the author's prior written consent and information derived from it should be acknowledged.”

Acknowledgements

I feel that anything I write here will never give justice to all those wonderful people who have helped see me through this. I could probably write a whole chapter in an attempt to include everyone and all they have done. Needless to say, there are many names and deeds that should doubtless be included here but are not.

First and foremost, my thanks have to go to my supervisor Prof. Marc Knight for endless support, patience and for maintaining faith in my abilities when I faltered. Your assistance goes far beyond that of the role of supervisor and truly made a difference.

My thanks to Dr. Bob Baxter for inspiring me throughout my undergrad and masters and continuing to offer help and support throughout my PhD. I always know I can go to you for friendly help and advice.

Thanks have to go to Dr. Heather Knight, for offering different perspectives but most importantly for hiding the lab19 “food crate” and being a conspirator for delivering celebrations.

My thanks to all the wonderful people in or that have passed through lab 19 who have made that lab such a joy to be in. With special thanks: To Paige, my co-conspirator, for all the walks and talks and general silliness, you made a huge difference. To May for your hugs, enthusiasm and ability to follow and engage the bizarre tracks of conversation my mind takes at times. To Bryony for your complete insanity and the joy and happiness such madness brings. To Tracey for providing some balance and sanity. To Fieka and Steph for your (apparent!) calm and common sense. Finally, to Beccy for tolerating all the questions and helping to keep the lab running.

Thanks to BBSRC for providing funding.

Thanks go to my parents for their massive support at every stage.

To Sam and Finn; two truly good dogs. To Sam for trying to see me through from my first undergrad year to last PhD (although you did not quite make it, I know that you tried and would have met the news of completion with your customary grin and tail wag). To Finn for bravely stepping up to the plate keeping me sane during the final stages of writing, keeping careful watch by my side, providing moral support and companionship as I wrote and reminding me there is always still time to go outside.

Finally, to Rob, for being there and supporting through my entire university career and everything the PhD and life has thrown at me. For always listening to my ramblings and for tirelessly keeping the rest of life running in the background whilst I wrote and providing me with, and reminding me to eat, proper food.

“It's a dangerous business... going out your door. You step onto the road, and if you don't keep your feet, there's no knowing where you might be swept off to.”

Chapter 1: Introduction

1.1 General Background

1.1.1 Freezing

Freezing events can be problematic for plants. When exposed to temperatures below their tolerance level severe damage and death can occur. The level of tolerance of plants varies greatly: some plants cannot tolerate temperatures below 0 °C, whilst others have been shown as being capable of surviving temperatures below -196 °C (Stushnoff and Junttila, 1986). -196 °C is colder than any temperature ever recorded upon Earth; the lowest ever recorded temperature being -92 °C in Antarctica (Phillips, 2013), although plants do not grow at this location due to other limiting factors (and temperatures this low incur other problems aside from freezing; such as the transition of CO₂ from gaseous to solid phase). It is therefore possible for some plants to tolerate the minimum temperature of any earthly environment where other requirements for growth are met. However, other plants are incapable of surviving temperatures below freezing point and a wide spectrum of tolerances between these two extremes exist.

The freezing tolerance of a species limits its distribution. This is demonstrated by hardiness zone maps on which locations are scored given their annual average extreme minimum temperature and then plants are categorised to a zone hardiness based on the minimum temperatures they can tolerate. The most commonly used is The United States Department of Agriculture (USDA) plant hardiness zone system (United States Department of Agriculture, 2018). This system is heavily used worldwide to identify where plants can be grown without dying due to low/freezing temperatures. Species cannot expand into (or be cultivated in) environments which may be otherwise favourable if they are incapable of surviving the minimum temperature of that environment. This

also limits available crop species that can be grown in certain environments. Therefore, understanding the mechanisms of freezing tolerance and how species respond to freezing is key to understanding, and modifying, their distribution as well as predicting distribution changes in response to climate change.

1.1.2 Acclimation

The ability to tolerate freezing is not a static state but is induced (or increased) via the process of cold acclimation. Not all plants are capable of cold acclimating and are therefore incapable of surviving freezing. One of the stimuli known to induce acclimation is exposure to low, but non-freezing, temperatures. This results in a change in the transcriptome (Fowler and Thomashow, 2002, Wang et al., 2013, Winfield et al., 2010, Hannah et al., 2005, Svensson et al., 2006, Lee et al., 2005) with the regulation of an estimated >10,000 genes altering in response to cold in *Arabidopsis thaliana* (Hannah et al., 2005). This leads to a variety of biochemical changes which increases freezing tolerance (Cook et al., 2004, Gilmour et al., 2000). One cold response pathway, that leads to acclimation is the CBF (C-repeat Binding Factor) pathway (simplified in Fig. 1.1.2.1). The basic premise of the response is that upon sensing low (non freezing) temperatures a signalling cascade leads to the increase in the transcription factor ICE1 (Inducer of CBF Expression 1) which upregulates the CBF transcription factors, which, in turn, alter expression of a large number (414 In *Arabidopsis thaliana* (Zhao et al., 2016)) of *COR* genes leading to acclimation. This pathway responds rapidly, with the time between exposure to low (non freezing) temperatures and increased *CBF* expression taking approximately ~15 minutes in *Arabidopsis thaliana* and peaking at around 2 hours (Gilmour et al., 1998, Medina et al., 1999). Evidence exists for other pathways which also lead to acclimation (such as the change in gene regulation due to cold estimated to be >10,000 genes (Hannah et al., 2005) as opposed to 414 genes by CBF transcription factors

(Zhao et al., 2016)) but are not as highly studied as the *CBF* pathway (which, itself, is still not fully understood). Reduction or loss of freezing tolerance occurs via deacclimation, one of the stimuli which is associated with this process is prolonged warm temperatures (Kalberer et al., 2006).

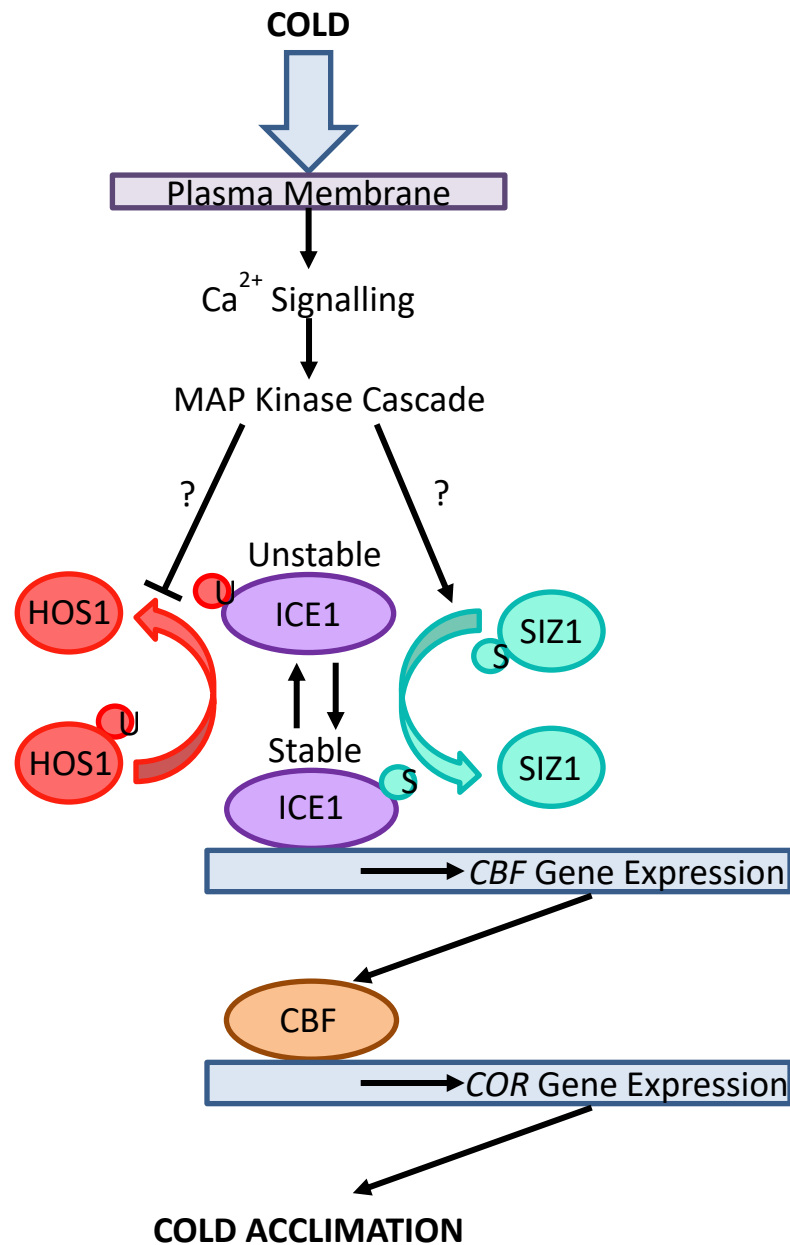

Figure 1.1.2.1 Depicting current proposed model for the CBF pathway of cold acclimation, as based upon *Arabidopsis thaliana*. S denotes SUMO and U denotes ubiquitin. CBF stands for the cold responsive members of the CBF transcription family (CBF1-3 in *Arabidopsis thaliana*).

1.2 The Effect of Climate Change

1.2.1 The Effect of Climate Change upon Acclimation and Native Plants

Climate change is affecting when plants acclimate and deacclimate due to altering the timing of stimuli which naturally induce acclimation or deacclimation as well as altering winter temperatures. Shortened winters lead to later acclimation and earlier deacclimation putting plants at greater risk of sudden frosts occurring outside of their acclimated period. More extreme winter freezing temperatures are also predicted to occur (Petoukhov and Semenov, 2010) which could kill plants incapable of tolerating those temperatures. Winter warm periods are also increasing in frequency and length (Shabbar and Bonsal, 2003, Beniston, 2005, IPCC Working Group I, 2013) therefore increasing the likelihood of midwinter deacclimation. These warm periods, coupled with increased rainfall can also result in the loss of insulating snow cover (Räsänen and Eklund, 2012, IPCC Working Group II, 2014) which, upon a decrease in temperatures again, exposes plants to colder than usual temperatures. Loss of snow cover has been shown to lead to the death of more sensitive plants which rely upon snow cover in alpine environments (Wheeler et al., 2014, Rixen et al., 2012) and severe damage to plants in arctic environments (Bokhorst et al., 2009). It is unlikely that this damage is exclusively due to the loss of insulating snow cover but rather deacclimation (or a reduction in the degree of acclimation) for example *Empetrum nigrum* has been recorded as capable of tolerating -80 °C upon acclimation (with a 70 % survival rate) (Yamori et al., 2005) yet severe damage of this species after the loss of snow-cover has been observed in subarctic (Bokhorst et al., 2009) and alpine (Rixen et al., 2012) environments. It is unlikely that temperatures as low as or lower than -80 °C were experienced after the snow melt, however *Empetrum nigrum* is only capable

of tolerating temperatures around -15 °C (~80 % survival rate) prior to acclimation (Yamori et al., 2005). It therefore seems likely that this warm period also resulted in full or partial deacclimation therefore leaving *Empetrum nigrum* susceptible to low temperature damage. It should be noted, however, that the freezing tolerance study was performed upon samples from the Japanese Mt Iwo whereas the survival studies were performed in the Swiss Alps and Northern Scandinavia. They are therefore not directly comparable, as it is possible there is also natural variation in the populations effecting freezing tolerance.

Empetrum nigrum is a dominant understory species in the subarctic and is also common throughout moorlands. *Calluna vulgaris* is a dominant moorland species in the UK. Both of these environments are key carbon stores. Loss or severe damage to these species due to winter warming would have a large impact upon these environments. For example; loss of these cover species would result in areas of exposed peat or tundra. Exposed areas, now lacking the stabilising plant cover, are subject to erosion of surface soils. Re-establishment of plants on these easily eroded surfaces can prove difficult as exemplified by the necessity of peatland restoration programs in areas where peatland plant cover has been lost due to other environmental and anthropological factors. This is especially difficult where further weathering has resulted in steep slopes of peak tussocks which must be flattened prior to reintroduction to enable establishment of plants (Moors For The Future Partnership, 2019). This erosion combined with oxidation and cessation of carbon uptake due to loss of species results in carbon storage loss, increasing the problems of climate change (Evans et al., 2006). Heavily damaged areas of bare environment lose the “cultural service value” i.e. the effects of landscape beauty such as health and wellbeing, tourism, recreation etc (North Pennines AONB Partnership, 2019). Loss of these species can also impact upon the commercial and cultural value, for example *Empetrum nigrum* is a minor crop in its own right and is also grazed by reindeer herds (Inga and Öje, 2012)

which are vital for the livelihoods of indigenous reindeer herders such as the Sami (Heikkilä, 2002). Change in the dominant species cover also disrupts the ecosystem, altering plant diversity and therefore the animal and fungal life which relies on these species. Even if the loss of cover of these species occurred gradually allowing for changes in vegetation rather than sudden loss (which would depend upon the natural variation in tolerance within the population – which this study, in part, intends to investigate) Changes in vegetation distribution may also alter how much of the incident solar radiation is reflected back or absorbed via altering the albedo (i.e. altering the reflectivity of the earth's surface), changing carbon storage and uptake, soil-vegetation interactions and impacting upon other ecological processes (ACIA, 2005). Therefore, understanding the molecular mechanisms and timings of freezing tolerance acquisition and maintenance in these species is of high importance to both predict how this species will be affected by climate change and also determine if variation exists within the species which is capable of tolerating these changes. If so this information can be utilised to influence reintroduction and maintenance programs. Cost of restoring greater than that of maintaining (North Pennines AONB Partnership, 2019) therefore prioritising maintenance via knowledge of susceptibility of different systems is also economically advisable.

1.2.2 The Effect of Climate Change upon Crops

Changes in climate, especially early and late frosts (relative to the acclimated period) are also a significant problem for crops, resulting in large scale crop loss worldwide e.g. (Brammer, 2018, News Staff, 2012, Ewing, 2013, The Local, 2017, Park, 2018) there is therefore great impetus to breed crops capable of surviving these events. Increased hardiness is also desirable to increase viable locations for crops to be grown and prepare for predicted increases in winter extreme freezing events (Petoukhov and Semenov, 2010). Genes involved in cold acclimation and freezing resistance therefore need to be

targeted by crop breeders to improve crop resistance to these climatic events. Plants already adapted to environments which experience extreme freezing events plus year-round frosts, such as those in arctic and alpine locations, are likely to already possess genetic differences which account for improved freezing tolerance and hence it is logical to investigate the potential of these genes as targets for crop breeding.

1.3 Potential Gene Sources For use in Crops

Arctic and alpine plants are generally, by necessity, very freezing tolerant. For example, on a yearly basis, weather stations within a 120 mile radius of one of our Swedish collection sites, Abisko (68.3500°N, 18.8167 E°) record winter extreme lows of -35 °C to -50 °C (Norwegian Meteorological Institute and Norwegian Broadcasting Corporation, 2007-2014). Plants exposed to these temperatures, especially those above the snow-lie, therefore need to be capable of surviving these, and potentially lower, temperatures. In their 1986 paper Stushnoff & Junttilla identified the LST66 (lowest survival temperature at which 66 % of samples showed no damage) of 17 species from nearby northern Norway, four of which included crop genera - namely: *Rubus*, *Ribes* and *Prunus*. The LST66 of these species ranged from -15 °C (where the plants probably rely on sheltered spots or deep snow lie to insulate them from the coldest temperatures) to -50 °C for the crop genera and from -15 °C to below -196 °C for all other species (Stushnoff and Junttilla, 1986). Yamori et al., (2005) studied a further nine species from alpine locations in Japan, which after acclimation, showed over a 60 % survival rate at -80 °C. Prior to acclimation these species were “only” freezing tolerant (with an LT60) to between -10 °C and -20 °C (Yamori et al., 2005). These plants are therefore able to tolerate freezing events (to between -10 and -20 °C) pre-acclimation. The majority of crop plants however are killed at much warmer subzero temperatures outside of the acclimated winter period therefore

an understanding of how arctic and alpine plants tolerate freezing could prove highly advantageous to the breeding of crops.

Likely targets of altered molecular function to improve freezing tolerance are genes involved in acclimation; influencing the degree of freezing tolerance, when acclimation occurs and at what rate. A large number of genes are upregulated in response to cold (Fowler and Thomashow, 2002, Winfield et al., 2010, Wang et al., 2013, Hannah et al., 2005, Svensson et al., 2006, Lee et al., 2005), therefore large scale modification of numerous genes would be required to alter freezing tolerance at the end of the pathway. Genes activated early in the process of acclimation which encode transcription factors which influence a large number of other genes are, therefore, more likely targets of selection. A likely candidate gene family encoding transcription factors which influence freezing tolerance is the *CBF* (C-repeat Binding Factor) family.

1.4 C-Repeat Binding Factor (CBF)

1.4.1 The Importance of CBF in Cold Acclimation and Freezing Tolerance

Some members of the *CBF* family are rapidly upregulated in response to cold (Gilmour et al., 2004, Gilmour et al., 1998) and/or a shortened photoperiod (Lee and Thomashow, 2012), as part of the acclimation pathway (Fig. 1.1.2.1). CBFs bind to the C-Repeat/Dehydration Response Element (CRT/DRE) found in promoters of cold regulated (*COR*) genes (Canella et al., 2010, Stockinger et al., 1997, Liu et al., 1998) and alter the activation of these *COR* genes ultimately resulting in increased freezing tolerance (Thomashow et al., 2001, Gilmour et al., 2000, Gilmour et al., 1998, Gilmour et al., 2004, Jaglo-Ottosen et al., 1998). *CBF* genes are found even in plants that cannot tolerate freezing (Zhang et al., 2004, Ito et al., 2006). Introduction of *CBF* genes from a species

which can cold acclimate to tolerate freezing into one that is freezing sensitive has been shown to confer freezing tolerance to the freezing sensitive species such as *A. thaliana* *CBFs* in *Solanum tuberosum* (Pino et al., 2007) and *Triticum spp. CBFs* in *Nicotiana benthamiana* (Takumi et al., 2008). However introduction of non-native *CBF* genes does not always confer freezing tolerance to all freezing sensitive species such as seen in *A. thaliana CBF* genes in *Solanum lycopersicum* (Zhang et al., 2004). Constitutive overexpression of native *CBF* genes in freezing tolerant species confers constitutive freezing tolerance (Jaglo-Ottosen et al., 1998, Gilmour et al., 2000). However, this often results in reduced yields and a dwarf phenotype (Achard et al., 2008, Gilmour et al., 2000, Liu et al., 1998, Suo et al., 2012). As with previous overexpression studies constitutive overexpression of *A. thaliana CBF* genes in *Solanum tuberosum* also resulted in smaller leaves, stunted plants, delayed flowering, and reduced, or lack of, tuber production (Pino et al., 2007). However, addition of these *CBF* under a stress-inducible promoter (as opposed to a constitutive promoter), provided the ability for that species to acclimate and tolerate mild freezing with no change in yield (Pino et al., 2007). Interestingly overexpression of *Triticum spp. CBF* into tobacco did not result in reduced growth but did increase freezing tolerance (Takumi et al., 2008). It is therefore possible that mutations may exist in *CBF* genes that do not result in the associated stunted growth and reduced yield. This stunting may also be overcome by use of a cold-inducible *CBF* promoter, as seen in *Solanum tuberosum* (Pino et al., 2007). Since *CBF* genes are capable of altering freezing tolerance, either within a species via upregulation or via insertion of *CBF* genes from more freezing tolerant species into less freezing tolerant species and are present in numerous species, across the Spermatophyta, including crop and arctic species it seems likely mutations may exist naturally that confer greater freezing tolerance. This family of transcription factors are therefore a likely candidate for investigation for

understanding differences in freezing tolerance between and within species and as a target for crop breeding.

1.4.2 Key Domains within the CBF Protein

Two main protein sequence domains have been identified as important in the activity of CBF: The *COR* binding domain, consisting of the AP2/ERF domain (Sakuma et al., 2002) and the flanking PKKP/RAGR_xKF_xETRHP (PKKPAGR) and DSAWR sequences (Canella et al., 2010), and the COOH terminus (Wang et al., 2005) (Fig. 1.4.2.1).

Within the RKKFR motif (a region predicted to form an α -helix) of the PKKPAGR sequence several key amino acids related to binding have been identified, namely; R(7) and F(10) (Canella et al., 2010). Substitution of these amino acids affects the ability of CBF to bind to the CRT/DRE element. Conserved and non-conserved substitution of R(7) significantly impaired binding. Non-conserved substitution of F(10) with A or P prevented binding however a conserved substitution of F(10) to Y greatly enhanced binding (Canella et al., 2010). Other substitutions in this region namely K(8) to R (conserved) and A (non conserved), K(9) to R (conserved) and A (non conserved) and R(11) to S (non conserved); all had no significant effect on binding (Canella et al., 2010). Another amino acid that was found to be key to binding is V(14) in the AP2/ERF domain; a conserved substitution of which with A prevented binding (Sakuma et al., 2002). It is therefore possible that substitutions in these regions, altering the binding ability of CBF to the CRT/DRE element may therefore result in a different degree of expression of the target genes. A series of hydrophobic loops in the COOH domain have been shown to affect the ability of CBF to activate target genes (Wang et al., 2005). The authors found this trend of groups of hydrophobic clusters to be conserved across several plant taxa.

However there was a high degree of redundancy in the system whereby multiple loops could be disrupted before there was any effect upon activity (Wang et al., 2005).

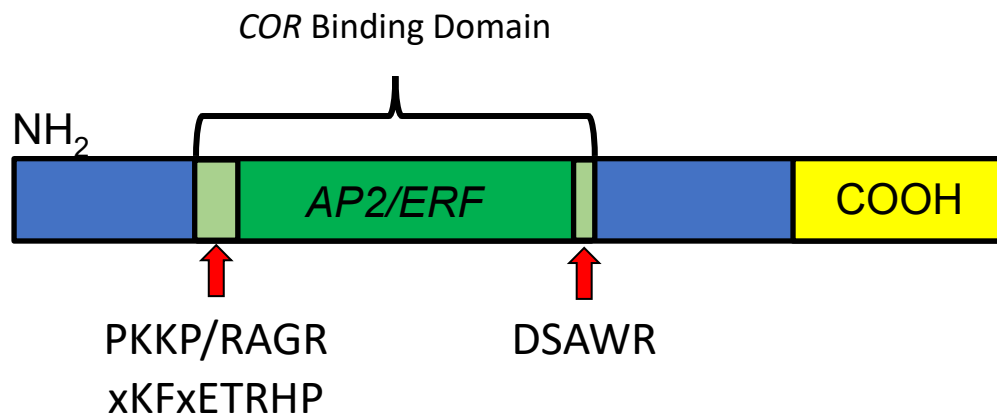

Figure 2.4.2.1 Schematic of CBF protein sequence based upon *Arabidopsis thaliana* CBF1-4, showing relative positions domains discussed: The COOH terminus (yellow) and the COR binding domain (green) consisting of the AP2/ERF domain (dark green) and CBF signature sequences PKKP/RAGR xKFxETRHP and DSAWR (pale green). *NOT TO SCALE*

1.5 Scope of the Thesis

The aforementioned information about the structure of CBF proteins and their influence on binding and activation activity can therefore be used to predict the activity of proteins from sequenced *CBF* genes from arctic and alpine plants. Protein sequences of the same species from different locations which experience a different degree of freezing stress can also be compared, which may indicate key polymorphisms which may correlate with greater freezing tolerance. This information can then be used to assess the potential of these polymorphisms as a target for crop breeding. Data from the same species from different locations can also be used to assess the genetic plasticity of these species and their robustness against upcoming climatic change.

1.5.1 Thesis Aims & Rationales

There are two main overarching rationales for the studies undertaken in this project:

1. To protect the world's crop food sources against freezing damage and loss *via* an attempt to identify, if possible, a way to alter freezing tolerance or freezing response without impacting upon yield.
2. To identify methods to predict key plant species responses to climate change and the genetic variation in responses to climate change in order to influence restoration and conservation projects.

Therefore, two approaches were used:

- A. Plants from environments which experience extreme winter temperatures and regular risk of frosts may contain mutations in their *CBF* genes which confer greater freezing tolerance. By comparing *CBF* sequences from these species it may be possible to identify polymorphisms which confer greater freezing tolerance which could then ultimately be screened for in crop species to identify potentially more freezing resistant strains, without the need for genetic modification. (Aims 1-3)
- B. A species that occupies a wide environmental range, therefore experiencing differing maxima and timing of freezing events, may therefore, exhibit differing freezing responses across this environmental range. If a difference is present, knowledge of this and the genetic basis, would prove useful to restoration and conservation projects. Introduction of plants from areas with certain genetic responses to freezing which would prove the most favourable for successful establishment and growth in the environment (or predicted future environment) undergoing restoration would be advantageous. Knowledge of the genetic

variability would also be useful in conservation projects to prioritise conservation efforts, to avoid loss of this genetic variability. Any genetic differences identified could also potentially prove useful in informing further studies for crop breeding as in point A. (Aims 4-8)

To this end the specific aims and rationale for experiments undertaken in this thesis were:

1. To isolate novel *CBF* sequences from a wide variety of arctic, alpine and moorland plants (Chapter 3);
 - In order to provide a large collection of *CBF* sequences from a wide range of species that naturally experience extreme freezing and/or early late frosts in order to provide a basis from which to address aim 2.
2. To identify polymorphisms common across multiple arctic and alpine species which may be of interest for altering freezing tolerance (Chapter 3);
 - In order to identify the most likely polymorphisms that alter *CBF* binding or activity and therefore freezing tolerance which could then be tested empirically for inducing changes to freezing tolerance (aim 3).
3. To test the effect of these polymorphisms upon freezing tolerance and the ability to activate *COR* genes when introduced into *Arabidopsis thaliana* *CBF1* (Chapter 4);
 - In order to empirically test the polymorphisms identified in aim 2 for changes in binding and activation, downstream gene expression and overall freezing tolerance. Any advantageous polymorphisms identified could then, (outside the scope of this thesis) be tested in crops with the aim of informing crop breeding.
4. To identify and assess the potential for specific arctic, alpine or moorland species to be experimental models (Chapter 5);

- In order to identify suitable species and methods of growth and propagation to address aims 5-8.
5. To compare and identify differences between *CBF* sequences from *Empetrum nigrum* samples taken from across a wide environmental range (Chapter 5);
 - In order to identify if polymorphisms exist in the sequence of *Empetrum nigrum CBF* across the environmental range which could be responsible for different freezing tolerances or responses. If present, these polymorphisms could be tested as per aim 3.
 6. To establish methods to assess *CBF* expression kinetics and freezing tolerance in *Empetrum nigrum* (Chapter 5);
 - In order to identify if these methods can be successfully adapted to this species in order to address aim 7.
 7. To identify if there is any difference in *CBF* expression kinetics between *Empetrum nigrum* plants grown in common garden conditions from cuttings taken from differing environmental locations (Chapter 5);
 - In order to see if the same species from different environments has different *CBF* expression kinetics, indicating local selection of different freezing responses. If so, this could influence the survival chances of plants from certain populations when introduced elsewhere during restoration programs and could be used to predict probable responses of those populations to environmental changes. If a difference is present this could also form the basis of further exploration into the possible cause and effect and provide potential gene targets for crop breeding.
 8. To assess if there is any correlation between observed morphology of *Empetrum nigrum* and *Calluna vulgaris* plants grown in common garden conditions from

cuttings taken from differing environmental locations and the environment of origin (Chapter 5).

- To identify if there is a genetic or epigenetic influence of origin upon morphology which may indicate population differences. This would be useful knowledge for predicting responses to environmental change, and to influence reintroduction & conservation programs.

Chapter Two: Materials and Methods

2.1 Sample Collection

2.1.1 Collection

Seventy-seven plant samples were collected from various sites across Abisko, Northern Sweden (Table 2.1.5) between 17/07/14 & 19/07/14. One *Fragaria vesca* sample was collected on 21/07/14 in the Northern Pennines, UK (Table 2.1.5) by Professor Marc Knight and Dr. Heather Knight. A further fifty samples were collected from the sites across the Northern Pennines, UK on 23/07/14 & 24/7/14 (Table 2.1.5).

Forty samples were collected by Dr. Adrian Brennan on 18/06/2015 from various sites across Abisko, Northern Sweden. In August 2016 nine samples from Abisko, Northern Sweden were collected by Dr. Johan Olofsson and ten samples from near Trondheim, Norway were collected by Dr. Annika Hofgaard (Table 2.1.5).

Calluna vulgaris var. Con Brio and *Calluna vulgaris var. kinlochruel* plants rooted in 2 l pots were purchased from Poplar Tree Garden Centre, Durham in April 2016.

Cuttings from six plants were collected from various sites across Nags Head, North Pennines, UK on 13/11/15. A further six were collected from sites across the North Pennines (Table 2.1.5) on 16/11/2015. Numerous samples were taken for both DNA and propagation across the UK: Fifty samples were taken from various sites across the Cairngorms, Highland Scotland between 12-14/07/2016, twenty-one samples were taken from sites across Exmoor, Southern England between 27-28/07/2016, twenty samples from Galloway, Southeast Scotland between 23-24/08/2016, thirty-one samples from the Yorkshire Moors, Northeast England between 30-31/08/2016, twenty-five samples from

south Wales between 13-14/09/2016 and twenty Seven from Derbyshire, Midlands, England on 19-20/09/2016 (Table 2.1.5).

2.1.2 Transport and Storage

Samples collected from Abisko, Northern Sweden in 2014 were kept cool and damp (for a maximum of 3 Days) until return to Durham University, UK where they were then stored at -80 °C. After collection, samples from the Northern Pennines, UK were immediately transported to Durham University, UK and stored at -80 °C.

Samples from sites across the UK were stored in cool bags with damp tissue. For a maximum of 3 days before transport back to Durham University, UK. Tissue for cuttings were treated as per section 2.2.2 and (where samples were sufficiently large) some tissue was stored at -80 °C whilst the remainder was dried on Sigma-aldrich Honeywell Silica Gel Orange in a drying oven, before storing in vacuum desiccators or boxes containing Sigma-aldrich Honeywell Silica Gel Orange.

Samples collected by Dr. Annika Hofgaard and Dr. Johan Olofsson were dried prior to postage to Durham University, UK and upon arrival they were stored in vacuum desiccators. Samples collected by Dr. Adrian Brennan, were bagged before travelling back to Durham University, UK where they were then dried on Sigma-aldrich Honeywell Silica Gel Orange.

2.1.3 Identification

Photos for species identification after 10/2/14 were taken at the time of collection using a combination of Nikon D80 DSLR, Olympus OMD EM10II and a Pentax WG1 compact camera.

Species identification was performed using a combination of identification guides: British Bryological Society (2010), Cope and Gray (2009), Poland and Clement (2009), Stenberg and Mossberg (2006), Rose (2006), Blamey et al. (2003), Fitter et al. (1992), Rose (1989), Jermy et al. (1982).

2.1.4 Soil pH Calculation

Soil samples were taken at sites where *Empetrum nigrum* and *Calluna vulgaris* samples for cuttings were collected, where possible, using a soil auger. This soil was stored at 4 °C for a maximum of 4 months until measured. 50 % soil was mixed with 50 % H₂O swirled and left to settle for 15 minutes. The pH measurement was then taken using a Milwaukee Mi 180 Bench Meter.

Table 2.1.5a. Table listing details for samples collected as per section 2.1.1. Showing the individual sample code, name of the collector of the sample, species identification (N.B. “?” indicates uncertainty with identification either due to being outside of the expected range or due to altered morphology under extreme environments often combined with limitations of vegetative identification), Site code, general location collected from, altitude (m above sea level), latitude and longitude of the collection site (either in the degrees, minutes, seconds or decimal degrees format) slope and aspect (where present), Soil pH (where recorded) and any additional details recorded.

Sample code	Collector	Species	Site	Location	Altitude (m)	Latitude	Longitude	decimal latitude	decimal longitude	Slope/ aspect	pH	Additional Details
1	Alice Rowland	<i>Deschampsia cespitosa??</i> <i>Avena??</i>	1	Sweden; Abisko	576	N 68° 19.131'	E 018° 50.560'	68.31885	18.842667		N/A	
2	Alice Rowland	<i>Diapensia lapponica</i>	2 (north)	Sweden; Abisko	590	N 68° 19.044'	E 018° 50.751'				N/A	
3	Alice Rowland	<i>Arctostaphylos alpina</i>	2 (north)	Sweden; Abisko	590	N 68° 19.044'	E 018° 50.751'				N/A	
4	Alice Rowland	<i>Betula nana</i>	2 (north)	Sweden; Abisko	590	N 68° 19.044'	E 018° 50.751'				N/A	
5	Alice Rowland	<i>Empetrum nigrum</i>	2 (north)	Sweden; Abisko	590	N 68° 19.044'	E 018° 50.751'				N/A	
6	Alice Rowland	<i>Loiseleuria procumbens</i>	2 (north)	Sweden; Abisko	590	N 68° 19.044'	E 018° 50.751'				N/A	
7	Alice Rowland	<i>Polytrichum piliferum?</i>	2 (north)	Sweden; Abisko	590	N 68° 19.044'	E 018° 50.751'				N/A	
8	Alice Rowland	<i>Dryas octopetala</i>	2 (west)	Sweden; Abisko	589	N 68° 19.038'	E 018° 50.753'				N/A	
9	Alice Rowland	<i>Silene acaulis</i>	2 (west)	Sweden; Abisko	589	N 68° 19.038'	E 018° 50.753'				N/A	
10	Alice Rowland	<i>Vaccinium vitis-idaea</i>	2 (S/E)	Sweden; Abisko	590	N 68° 19.037'	E 018° 50.776'				N/A	
11	Alice Rowland	<i>Deschampsia sp?</i>	2 (S/E)	Sweden; Abisko	590	N 68° 19.037'	E 018° 50.776'				N/A	
12	Alice Rowland	<i>Poaceae sp.</i>	2 (S/E)	Sweden; Abisko	590	N 68° 19.037'	E 018° 50.776'				N/A	
13	Alice Rowland	<i>Juniperus communis</i>	2 (S/E)	Sweden; Abisko	590	N 68° 19.037'	E 018° 50.776'				N/A	
14	Alice Rowland	<i>Linnaea borealis</i>	2 (S/E)	Sweden; Abisko	590	N 68° 19.037'	E 018° 50.776'				N/A	
15	Alice Rowland	<i>Polytrichum sp. Commune?</i>	2 (S/E)	Sweden; Abisko	590	N 68° 19.037'	E 018° 50.776'				N/A	
16	Alice Rowland	<i>Pleurozium schreberi</i>	2 (S/E)	Sweden; Abisko	590	N 68° 19.037'	E 018° 50.776'				N/A	
17	Alice Rowland	<i>Peltigera aphthosa</i>	2 (S/E)	Sweden; Abisko	590	N 68° 19.037'	E 018° 50.776'				N/A	
18	Alice Rowland	<i>Andromeda polifolia</i>	3	Sweden; Abisko	576	N 68° 19.057'	E 018° 50.754'				N/A	

Table 2.1.5b. Table listing details for samples collected as per section 2.1.1. Showing the individual sample code, name of the collector of the sample, species identification (N.B. “?” indicates uncertainty with identification either due to being outside of the expected range or due to altered morphology under extreme environments often combined with limitations of vegetative identification), Site code, general location collected from, altitude (m above sea level), latitude and longitude of the collection site (either in the degrees, minutes, seconds or decimal degrees format) slope and aspect (where present), Soil pH (where recorded) and any additional details recorded.

Sample code	Collector	Species	Site	Location	Altitude (m)	Latitude	Longitude	decimal latitude	decimal longitude	Slope/ aspect	pH	Additional Details
19	Alice Rowland	<i>Lycopodium annotinum</i>	4	Sweden; Abisko	475	N 68° 20.458'	E 018° 49.660'				N/A	
20	Alice Rowland	<i>Parmelia olivacea</i> (colour 1)	4	Sweden; Abisko	475	N 68° 20.458'	E 018° 49.660'				N/A	
21	Alice Rowland	<i>Parmelia olivacea</i> (colour 2)	4	Sweden; Abisko	475	N 68° 20.458'	E 018° 49.660'				N/A	
22	Alice Rowland	<i>Cladonia uncialis</i> (prob subsp <i>biuncialis</i>)	4	Sweden; Abisko	475	N 68° 20.458'	E 018° 49.660'				N/A	
23	Alice Rowland	<i>Diphasiastrum complanatum</i>	4	Sweden; Abisko	475	N 68° 20.458'	E 018° 49.660'				N/A	
24	Alice Rowland	<i>Cetrelia olivetorum?</i>	4	Sweden; Abisko	475	N 68° 20.458'	E 018° 49.660'				N/A	
25	Alice Rowland	<i>Equisetum palustre</i>	4	Sweden; Abisko	475	N 68° 20.458'	E 018° 49.660'				N/A	
26	Alice Rowland	<i>Cornus suecica</i>	5	Sweden; Abisko	430	N 68° 25.924'	E 018° 31.018'				N/A	
27	Alice Rowland	<i>Juncus trifidus</i>	6	Sweden; Abisko	507	N 68° 26.091'	E 018° 06.740'	68.43485	18.112333		N/A	Exposed ground near Norway
28	Alice Rowland	<i>Carex cabescens?</i>	6	Sweden; Abisko	507	N 68° 26.091'	E 018° 06.740'	68.43485	18.112333		N/A	Exposed ground near Norway
29	Alice Rowland	<i>Luzula pilosa?</i>	6	Sweden; Abisko	507	N 68° 26.091'	E 018° 06.740'	68.43485	18.112333		N/A	Exposed ground near Norway
30	Alice Rowland	<i>lcmadophila ericetorum?</i>	6	Sweden; Abisko	507	N 68° 26.091'	E 018° 06.740'	68.43485	18.112333		N/A	Exposed ground near Norway
31	Alice Rowland	<i>Cladonia coccifera</i>	6	Sweden; Abisko	507	N 68° 26.091'	E 018° 06.740'	68.43485	18.112333		N/A	Exposed ground near Norway
32	Alice Rowland	<i>Stereocaulon sp.</i> (<i>pileatum, dactylophyllum, nanodes or vesuvianum</i>)	6	Sweden; Abisko	507	N 68° 26.091'	E 018° 06.740'	68.43485	18.112333		N/A	Exposed ground near Norway
33	Alice Rowland	<i>Eriphorum scheuchzeri</i>	6	Sweden; Abisko	507	N 68° 26.091'	E 018° 06.740'	68.43485	18.112333		N/A	Exposed ground near Norway
34	Alice Rowland	<i>Carex nigra var juncea</i>	6	Sweden; Abisko	507	N 68° 26.091'	E 018° 06.740'	68.43485	18.112333		N/A	Exposed ground near Norway

Table 2.1.5c. Table listing details for samples collected as per section 2.1.1. Showing the individual sample code, name of the collector of the sample, species identification (N.B. “?” indicates uncertainty with identification either due to being outside of the expected range or due to altered morphology under extreme environments often combined with limitations of vegetative identification), Site code, general location collected from, altitude (m above sea level), latitude and longitude of the collection site (either in the degrees, minutes, seconds or decimal degrees format) slope and aspect (where present), Soil pH (where recorded) and any additional details recorded.

Sample code	Collector	Species	Site	Location	Altitude (m)	Latitude	Longitude	decimal latitude	decimal longitude	Slope/ aspect	pH	Additional Details
35	Alice Rowland	<i>Physcia caesia</i> (several other possibilities)	6	Sweden; Abisko	507	N 68° 26.091'	E 018° 06.740'	68.43485	18.112333		N/A	Exposed ground near Norway
36	Alice Rowland	<i>Huperzia selago</i>	6	Sweden; Abisko	507	N 68° 26.091'	E 018° 06.740'	68.43485	18.112333		N/A	Exposed ground near Norway
37	Alice Rowland	<i>Kiaeria falcata?</i>	6	Sweden; Abisko	507	N 68° 26.091'	E 018° 06.740'	68.43485	18.112333		N/A	Exposed ground near Norway
38	Alice Rowland	<i>Gymnomitrium coninnatum</i>	6	Sweden; Abisko	507	N 68° 26.091'	E 018° 06.740'	68.43485	18.112333		N/A	Exposed ground near Norway
39	Alice Rowland	<i>Tetralophozia setiformis</i>	6	Sweden; Abisko	507	N 68° 26.091'	E 018° 06.740'	68.43485	18.112333		N/A	Exposed ground near Norway
40	Alice Rowland	<i>Vaccinium vitis-idaea</i>	6	Sweden; Abisko	507	N 68° 26.091'	E 018° 06.740'	68.43485	18.112333		N/A	Exposed ground near Norway
41	Alice Rowland	<i>Sphagnum compactum</i>	6	Sweden; Abisko	507	N 68° 26.091'	E 018° 06.740'	68.43485	18.112333		N/A	Exposed ground near Norway
42	Alice Rowland	<i>Dicranum scoparium??</i>	6	Sweden; Abisko	507	N 68° 26.091'	E 018° 06.740'	68.43485	18.112333		N/A	Exposed ground near Norway
43	Alice Rowland	<i>Andromeda polifolia</i>	6	Sweden; Abisko	507	N 68° 26.091'	E 018° 06.740'	68.43485	18.112333		N/A	Exposed ground near Norway
44	Alice Rowland	<i>Xanthoria candelaria</i>	6	Sweden; Abisko	507	N 68° 26.091'	E 018° 06.740'	68.43485	18.112333		N/A	Exposed ground near Norway
45	Alice Rowland	several possibilities inc. <i>Carbonea vitellinaria</i> , <i>Caloplaca xantholyta</i> , <i>Candelariella vitellina</i>	6	Sweden; Abisko	507	N 68° 26.091'	E 018° 06.740'	68.43485	18.112333		N/A	Exposed ground near Norway
46	Alice Rowland	<i>Ophioparma ventosa</i> (poss. Sub. <i>Festiva</i>)	6	Sweden; Abisko	507	N 68° 26.091'	E 018° 06.740'	68.43485	18.112333		N/A	Exposed ground near Norway
47	Alice Rowland	<i>Calluna domestic escapee?</i>	6	Sweden; Abisko	507	N 68° 26.091'	E 018° 06.740'	68.43485	18.112333		N/A	Exposed ground near Norway
48	Alice Rowland	<i>Ochrolechia frigida</i>	6	Sweden; Abisko	507	N 68° 26.091'	E 018° 06.740'	68.43485	18.112333		N/A	Exposed ground near Norway
49	Alice Rowland	<i>Solidago virgaurea</i> prob. ssp <i>alpestris</i>	6	Sweden; Abisko	507	N 68° 26.091'	E 018° 06.740'	68.43485	18.112333		N/A	Exposed ground near Norway

Table 2.1.5d. Table listing details for samples collected as per section 2.1.1. Showing the individual sample code, name of the collector of the sample, species identification (N.B. “?” indicates uncertainty with identification either due to being outside of the expected range or due to altered morphology under extreme environments often combined with limitations of vegetative identification), Site code, general location collected from, altitude (m above sea level), latitude and longitude of the collection site (either in the degrees, minutes, seconds or decimal degrees format) slope and aspect (where present), Soil pH (where recorded) and any additional details recorded.

Sample code	Collector	Species	Site	Location	Altitude (m)	Latitude	Longitude	decimal latitude	decimal longitude	Slope/ aspect	pH	Additional Details
50	Alice Rowland	<i>Athyrium sp.</i>	6	Sweden; Abisko	507	N 68° 26.091'	E 018° 06.740'	68.43485	18.112333		N/A	Exposed ground near Norway
51	Alice Rowland	<i>Salix herbacea</i>	6	Sweden; Abisko	507	N 68° 26.091'	E 018° 06.740'	68.43485	18.112333		N/A	Exposed ground near Norway
52	Alice Rowland	<i>Parnassia palustris</i>	6	Sweden; Abisko	507	N 68° 26.091'	E 018° 06.740'	68.43485	18.112333		N/A	Exposed ground near Norway
53	Alice Rowland	<i>Cladonia sulphurina?</i> (check which is 53 and which is 54)	6	Sweden; Abisko	507	N 68° 26.091'	E 018° 06.740'	68.43485	18.112333		N/A	Exposed ground near Norway
54	Alice Rowland	<i>Cladonia coccifera, polydacta?</i>	6	Sweden; Abisko	507	N 68° 26.091'	E 018° 06.740'	68.43485	18.112333		N/A	Exposed ground near Norway
55	Alice Rowland	-	6	Sweden; Abisko	507	N 68° 26.091'	E 018° 06.740'	68.43485	18.112333		N/A	Exposed ground near Norway
56	Alice Rowland	<i>Saussurea alpina</i>	7	Sweden; Abisko	369	N 68° 21.356'	E 018° 46.214'				N/A	Near River
57	Alice Rowland	<i>Antennaria alpina Or dioica</i>	8	Sweden; Abisko	397	N 68° 21.340'	E 018° 46.044'				N/A	
58	Alice Rowland	<i>Trifolium repens</i>	9	Sweden; Abisko	370	N 68° 21' 16"	E 018° 14' 57"				N/A	Research Station
59	Alice Rowland	<i>equisetum fluviatile</i>	10	Sweden; Abisko	482	N 68° 20.357'	E 018° 49.626'				N/A	Boggy board-walk
60	Alice Rowland	<i>Pseudobryum cinclidioides</i>	10	Sweden; Abisko	482	N 68° 20.357'	E 018° 49.626'				N/A	Boggy board-walk
61	Alice Rowland	<i>Sphagnum subnitens</i>	10	Sweden; Abisko	482	N 68° 20.357'	E 018° 49.626'				N/A	Boggy board-walk
62	Alice Rowland	ID not poss.	10	Sweden; Abisko	482	N 68° 20.357'	E 018° 49.626'				N/A	Boggy board-walk
63	Alice Rowland	<i>matricaria recutita?</i> (not that far north, but invaded?)	11	Sweden; Abisko	425	N 68° 20.737'	E 018° 49.870'				N/A	Disturbed ground near helipad and carpark
64	Alice Rowland	<i>Barbarea vulgaris?</i>	11	Sweden; Abisko	425	N 68° 20.737'	E 018° 49.870'				N/A	Disturbed ground near helipad and carpark

Table 2.1.5e. Table listing details for samples collected as per section 2.1.1. Showing the individual sample code, name of the collector of the sample, species identification (N.B. “?” indicates uncertainty with identification either due to being outside of the expected range or due to altered morphology under extreme environments often combined with limitations of vegetative identification), Site code, general location collected from, altitude (m above sea level), latitude and longitude of the collection site (either in the degrees, minutes, seconds or decimal degrees format) slope and aspect (where present), Soil pH (where recorded) and any additional details recorded.

Sample code	Collector	Species	Site	Location	Altitude (m)	Latitude	Longitude	decimal latitude	decimal longitude	Slope/ aspect	pH	Additional Details
65	Alice Rowland	<i>Hesperis matronalis?</i>	11	Sweden; Abisko	425	N 68° 20.737'	E 018° 49.870'				N/A	Disturbed ground near helipad and carpark
66	Alice Rowland	<i>Cardaminopsis arenosa</i>	11	Sweden; Abisko	425	N 68° 20.737'	E 018° 49.870'				N/A	Disturbed ground near helipad and carpark
67	Alice Rowland	<i>Anthriscus sylvestris??</i> <i>Really not sure carrot family like? (NOT A FERN!)</i>	11	Sweden; Abisko	425	N 68° 20.737'	E 018° 49.870'				N/A	Disturbed ground near helipad and carpark
68	Alice Rowland	<i>Capsella bursa-pastoris?</i>	12	Sweden; Abisko	405	N 68° 20.843'	E 018° 49.868'				N/A	Near Tourist-station and road
69	Alice Rowland	<i>Arabis alpina???</i>	12	Sweden; Abisko	405	N 68° 20.843'	E 018° 49.868'				N/A	Near Tourist-station and road
70	Alice Rowland	<i>Rumex acetosa?</i>	12	Sweden; Abisko	405	N 68° 20.843'	E 018° 49.868'				N/A	Near Tourist-station and road
71	Alice Rowland	<i>Arabis hirsuta?</i>	12	Sweden; Abisko	405	N 68° 20.843'	E 018° 49.868'				N/A	Near Tourist-station and road
72	Alice Rowland	<i>Pinus sylvestris</i>	13	Sweden; Abisko	N/A	N/A	N/A	N/A	N/A		N/A	
73	Alice Rowland	<i>Pinus sylvestris</i>	13	Sweden; Abisko	N/A	N/A	N/A	N/A	N/A		N/A	
74	Prof. Marc Knight & Dr. Heather Knight	<i>Fragaria vesca (Heather)</i>	14	England; North Pennines; Weardale	70	N 54° 44.582'	W 002° 08.839'				N/A	
75	Alice Rowland	<i>Picea abies</i>	15	England; North Pennines; Weardale	293	N 54° 44.285'	W 002° 08.797'				N/A	
76	Alice Rowland	<i>Juncus (inflexus? More resembles maritimus but not brackish...)</i>	16	England; North Pennines; Weardale	308	N 54° 44.508'	W 002° 08.828'				N/A	
77	Alice Rowland	<i>Trifolium repens</i>	16	England; North Pennines; Weardale	308	N 54° 44.508'	W 002° 08.828'				N/A	
78	Alice Rowland	<i>Fragaria vesca</i>	16	England; North Pennines; Weardale	308	N 54° 44.508'	W 002° 08.828'				N/A	

Table 2.1.5f. Table listing details for samples collected as per section 2.1.1. Showing the individual sample code, name of the collector of the sample, species identification (N.B. “?” indicates uncertainty with identification either due to being outside of the expected range or due to altered morphology under extreme environments often combined with limitations of vegetative identification), Site code, general location collected from, altitude (m above sea level), latitude and longitude of the collection site (either in the degrees, minutes, seconds or decimal degrees format) slope and aspect (where present), Soil pH (where recorded) and any additional details recorded.

Sample code	Collector	Species	Site	Location	Altitude (m)	Latitude	Longitude	decimal latitude	decimal longitude	Slope/ aspect	pH	Additional Details
79	Alice Rowland	<i>Ranunculus flammula</i>	16	England; North Pennines; Weardale	308	N 54° 44.508'	W 002° 08.828'				N/A	
80	Alice Rowland	<i>Juncus castaneus</i>	16	England; North Pennines; Weardale	308	N 54° 44.508'	W 002° 08.828'				N/A	
81	Alice Rowland	<i>Ranunculus acaris</i>	16	England; North Pennines; Weardale	308	N 54° 44.508'	W 002° 08.828'				N/A	
82	Alice Rowland	<i>Rumex sanguineus</i>	16	England; North Pennines; Weardale	308	N 54° 44.508'	W 002° 08.828'				N/A	
83	Alice Rowland	<i>Thuidium tamariscinum, Delicatulum, assimile (only distinguishable via microscopic features)</i>	17	England; North Pennines; Weardale	321	N 54° 44.503'	W 002° 08.833'				N/A	
84	Alice Rowland	<i>Dryopteris sp. (cristata?)</i>	17	England; North Pennines; Weardale	321	N 54° 44.503'	W 002° 08.833'				N/A	
85	Alice Rowland	<i>Carex sylvatica</i>	17	England; North Pennines; Weardale	321	N 54° 44.503'	W 002° 08.833'				N/A	
86	Alice Rowland	<i>Luzula sylvatica</i>	17	England; North Pennines; Weardale	321	N 54° 44.503'	W 002° 08.833'				N/A	
87	Alice Rowland	<i>Rhizomnium punctatum</i>	18	England; North Pennines; Weardale	290	N 54° 44.747'	W 002° 08.834'				N/A	
88	Alice Rowland	<i>plagiomnium undulatum</i>	18	England; North Pennines; Weardale	290	N 54° 44.747'	W 002° 08.834'				N/A	
89	Alice Rowland	<i>Anthriscus sylvestris?? Really not sure carrot family like? (NOT A FERN!)</i>	18	England; North Pennines; Weardale	290	N 54° 44.747'	W 002° 08.834'				N/A	
90	Alice Rowland	<i>Leucanthemum vulgare (note hairs so poss. not)</i>	19	England; North Pennines; Weardale	295	N 54° 44.366'	W 002° 08.762'				N/A	
91	Alice Rowland	<i>Xanthoria parietina?</i>	20	England; North Pennines; Weardale	290	N 54° 44.281'	W 002° 08.874'				N/A	
92	Alice Rowland	<i>Caloplaca sp??</i>	20	England; North Pennines; Weardale	290	N 54° 44.281'	W 002° 08.874'				N/A	
93	Alice Rowland	<i>Equisetum arvense</i>	21	England; North Pennines; Weardale	293	N 54° 44.250'	W 002° 09.845'				N/A	

Table 2.1.5g. Table listing details for samples collected as per section 2.1.1. Showing the individual sample code, name of the collector of the sample, species identification (N.B. “?” indicates uncertainty with identification either due to being outside of the expected range or due to altered morphology under extreme environments often combined with limitations of vegetative identification), Site code, general location collected from, altitude (m above sea level), latitude and longitude of the collection site (either in the degrees, minutes, seconds or decimal degrees format) slope and aspect (where present), Soil pH (where recorded) and any additional details recorded.

Sample code	Collector	Species	Site	Location	Altitude (m)	Latitude	Longitude	decimal latitude	decimal longitude	Slope/ aspect	pH	Additional Details
94	Alice Rowland	<i>Trifolium repens</i>	22	England; North Pennines; Weardale	497	N 54° 40.363'	W 002° 17.902'				N/A	
95	Alice Rowland	<i>Juncus conglomeratus</i>	22	England; North Pennines; Weardale	497	N 54° 40.363'	W 002° 17.902'				N/A	
96	Alice Rowland	<i>Yellow sedge, Carex flava, demissa or serotina</i>	22	England; North Pennines; Weardale	497	N 54° 40.363'	W 002° 17.902'				N/A	
97	Alice Rowland	<i>Pleurozium schreberi</i>	22	England; North Pennines; Weardale	497	N 54° 40.363'	W 002° 17.902'				N/A	
98	Alice Rowland	<i>Juncus squarrosus</i>	22	England; North Pennines; Weardale	497	N 54° 40.363'	W 002° 17.902'				N/A	
99	Alice Rowland	<i>Ranunculus repens</i>	22	England; North Pennines; Weardale	497	N 54° 40.363'	W 002° 17.902'				N/A	
100	Alice Rowland	<i>Deschampsia cespitosa</i>	22	England; North Pennines; Weardale	497	N 54° 40.363'	W 002° 17.902'				N/A	
101	Alice Rowland	<i>Equisetum palustre</i>	22	England; North Pennines; Weardale	497	N 54° 40.363'	W 002° 17.902'				N/A	
102	Alice Rowland	<i>Climacium dendroides</i>	22	England; North Pennines; Weardale	497	N 54° 40.363'	W 002° 17.902'				N/A	
103	Alice Rowland	<i>Equisetum palustre?</i>	22	England; North Pennines; Weardale	497	N 54° 40.363'	W 002° 17.902'				N/A	
104	Alice Rowland	<i>Didymodon insulanus?</i>	22	England; North Pennines; Weardale	497	N 54° 40.363'	W 002° 17.902'				N/A	
105	Alice Rowland	<i>Thymus polytrichus</i>	22	England; North Pennines; Weardale	497	N 54° 40.363'	W 002° 17.902'				N/A	
106	Alice Rowland	<i>Cladonia uncialis (prob subsp biuncialis)</i>	22	England; North Pennines; Weardale	497	N 54° 40.363'	W 002° 17.902'				N/A	
107	Alice Rowland	<i>Minuartia verna</i>	22	England; North Pennines; Weardale	497	N 54° 40.363'	W 002° 17.902'				N/A	
108	Alice Rowland	<i>Cladonia sp. (probably a more unusual one)</i>	22	England; North Pennines; Weardale	497	N 54° 40.363'	W 002° 17.902'				N/A	
109	Alice Rowland	<i>Trentepohlia sp. (Green alga!)</i>	22	England; North Pennines; Weardale	497	N 54° 40.363'	W 002° 17.902'				N/A	
110	Alice Rowland	<i>Rumex acetosa</i>	23	England; North Pennines; Weardale	522	N 54° 40.450'	W 002° 17.830'				N/A	

Table 2.1.5h. Table listing details for samples collected as per section 2.1.1. Showing the individual sample code, name of the collector of the sample, species identification (N.B. “?” indicates uncertainty with identification either due to being outside of the expected range or due to altered morphology under extreme environments often combined with limitations of vegetative identification), Site code, general location collected from, altitude (m above sea level), latitude and longitude of the collection site (either in the degrees, minutes, seconds or decimal degrees format) slope and aspect (where present), Soil pH (where recorded) and any additional details recorded.

Sample code	Collector	Species	Site	Location	Altitude (m)	Latitude	Longitude	decimal latitude	decimal longitude	Slope/ aspect	pH	Additional Details
111	Alice Rowland	<i>Rhytidiadelphus squarrosus</i>	23	England; North Pennines; Weardale	522	N 54° 40.450'	W 002° 17.830'				N/A	
112	Alice Rowland	<i>Aulacomnium palustre?</i>	24	England; North Pennines; Weardale	519	N 54° 40.483'	W 002° 17.756'				N/A	
113	Alice Rowland	<i>Juncus castaneus</i>	24	England; North Pennines; Weardale	519	N 54° 40.483'	W 002° 17.756'				N/A	
114	Alice Rowland	<i>Vaccinium myrtillus</i>	25	England; North Pennines; Weardale	626	N 54° 47.436'	W 002° 13.022'				N/A	
115	Alice Rowland	<i>Eriophorum angustifolium</i> (possibly others)	25	England; North Pennines; Weardale	626	N 54° 47.436'	W 002° 13.022'				N/A	
116	Alice Rowland	<i>Calluna vulgaris</i>	25	England; North Pennines; Weardale	626	N 54° 47.436'	W 002° 13.022'				N/A	
117	Alice Rowland	<i>Sphagnum sp. Angustifolium??</i> - check freezer sample more closely	25	England; North Pennines; Weardale	626	N 54° 47.436'	W 002° 13.022'				N/A	
118	Alice Rowland	<i>Vaccinium vitis idea</i>	25	England; North Pennines; Weardale	626	N 54° 47.436'	W 002° 13.022'				N/A	
119	Alice Rowland	<i>Anaptychia ciliaris??</i>	25	England; North Pennines; Weardale	626	N 54° 47.436'	W 002° 13.022'				N/A	
120	Alice Rowland	<i>Polytrichum juniperinum</i>	25	England; North Pennines; Weardale	626	N 54° 47.436'	W 002° 13.022'				N/A	
121	Alice Rowland	<i>Huperzia selago?</i>	26	England; North Pennines; Weardale	629	N 54° 42.051'	W 002° 12.863'				N/A	
122	Alice Rowland	<i>Cladonia coccifera</i> (poss. polydactyla)	26	England; North Pennines; Weardale	629	N 54° 42.051'	W 002° 12.863'				N/A	
123	Alice Rowland	<i>Lycopodium clavatum</i>	27	England; North Pennines; Weardale	629	N 54° 41.968'	W 002° 12.889'				N/A	
124	Alice Rowland	<i>Diphasiastrum/lycopodium alpinum</i>	27	England; North Pennines; Weardale	629	N 54° 41.968'	W 002° 12.889'				N/A	
125	Alice Rowland	<i>Lecideia lapicida?</i>	6	Sweden; Abisko	507	N 68° 26.091'	E 018° 06.740'	68.43485	18.112333		N/A	Exposed ground near Norway
126	Alice Rowland	<i>Lecanora polytropa??</i>	6	Sweden; Abisko	507	N 68° 26.091'	E 018° 06.740'	68.43485	18.112333		N/A	Exposed ground near Norway

Table 2.1.5i. Table listing details for samples collected as per section 2.1.1. Showing the individual sample code, name of the collector of the sample, species identification (N.B. “?” indicates uncertainty with identification either due to being outside of the expected range or due to altered morphology under extreme environments often combined with limitations of vegetative identification), Site code, general location collected from, altitude (m above sea level), latitude and longitude of the collection site (either in the degrees, minutes, seconds or decimal degrees format) slope and aspect (where present), Soil pH (where recorded) and any additional details recorded.

Sample code	Collector	Species	Site	Location	Altitude (m)	Latitude	Longitude	decimal latitude	decimal longitude	Slope/ aspect	pH	Additional Details
127	Alice Rowland	<i>Buellia aethalea?</i> <i>Rhizocarpon</i>	6	Sweden; Abisko	507	N 68° 26.091'	E 018° 06.740'	68.43485	18.112333		N/A	Exposed ground near Norway
128	Alice Rowland	<i>Toninia aromatica???</i> - <i>really not sure</i>	6	Sweden; Abisko	507	N 68° 26.091'	E 018° 06.740'	68.43485	18.112333		N/A	Exposed ground near Norway
130	Dr. Adrian Brennan	<i>Dryas octopetala</i>	28	Sweden; Abisko	520	N 68°19'32.3"	E 018° 50'47.6"			NE	N/A	Vegetated Hummocks
131	Dr. Adrian Brennan	<i>Dryas octopetala</i>	28	Sweden; Abisko	520	N 68°19'32.3"	E 018° 50'47.6"			NE	N/A	Vegetated Hummocks
132	Dr. Adrian Brennan	<i>Dryas octopetala</i>	28	Sweden; Abisko	520	N 68°19'32.3"	E 018° 50'47.6"			NE	N/A	Vegetated Hummocks
133	Dr. Adrian Brennan	<i>Empetrum nigrum</i>	28	Sweden; Abisko	520	N 68°19'32.3"	E 018° 50'47.6"			NE	N/A	Vegetated Hummocks
134	Dr. Adrian Brennan	<i>Empetrum nigrum</i>	28	Sweden; Abisko	520	N 68°19'32.3"	E 018° 50'47.6"			NE	N/A	Vegetated Hummocks
135	Dr. Adrian Brennan	<i>Empetrum nigrum</i>	28	Sweden; Abisko	520	N 68°19'32.3"	E 018° 50'47.6"			NE	N/A	Vegetated Hummocks
136	Dr. Adrian Brennan	<i>Empetrum nigrum</i>	28	Sweden; Abisko	520	N 68°19'32.3"	E 018° 50'47.6"			NE	N/A	Vegetated Hummocks
137	Dr. Adrian Brennan	<i>Saxifraga azoides</i>	28	Sweden; Abisko	520	N 68°19'32.3"	E 018° 50'47.6"			NE	N/A	Vegetated Hummocks
138	Dr. Adrian Brennan	<i>Saxifraga azoides</i>	28	Sweden; Abisko	520	N 68°19'32.3"	E 018° 50'47.6"			NE	N/A	Vegetated Hummocks
139	Dr. Adrian Brennan	<i>Saxifraga azoides</i>	28	Sweden; Abisko	520	N 68°19'32.3"	E 018° 50'47.6"			NE	N/A	Vegetated Hummocks
140	Dr. Adrian Brennan	<i>Dryas octopetala</i>	29	Sweden; Abisko	530	N 68°19'25.5"	E 018° 50'15.7"			None	N/A	Vegetated Hummocks with Wet Depressions
141	Dr. Adrian Brennan	<i>Dryas octopetala</i>	29	Sweden; Abisko	530	N 68°19'25.5"	E 018° 50'15.7"			None	N/A	Vegetated Hummocks with Wet Depressions
142	Dr. Adrian Brennan	<i>Dryas octopetala</i>	29	Sweden; Abisko	530	N 68°19'25.5"	E 018° 50'15.7"			None	N/A	Vegetated Hummocks with Wet Depressions
143	Dr. Adrian Brennan	<i>Empetrum nigrum</i>	29	Sweden; Abisko	530	N 68°19'25.5"	E 018° 50'15.7"			None	N/A	Vegetated Hummocks with Wet Depressions
144	Dr. Adrian Brennan	<i>Empetrum nigrum</i>	29	Sweden; Abisko	530	N 68°19'25.5"	E 018° 50'15.7"			None	N/A	Vegetated Hummocks with Wet Depressions

Table 2.1.5j. Table listing details for samples collected as per section 2.1.1. Showing the individual sample code, name of the collector of the sample, species identification (N.B. “?” indicates uncertainty with identification either due to being outside of the expected range or due to altered morphology under extreme environments often combined with limitations of vegetative identification), Site code, general location collected from, altitude (m above sea level), latitude and longitude of the collection site (either in the degrees, minutes, seconds or decimal degrees format) slope and aspect (where present), Soil pH (where recorded) and any additional details recorded.

Sample code	Collector	Species	Site	Location	Altitude (m)	Latitude	Longitude	decimal latitude	decimal longitude	Slope/ aspect	pH	Additional Details
145	Dr. Adrian Brennan	<i>Empetrum nigrum</i>	29	Sweden; Abisko	530	N 68°19'25.5"	E 018° 50'15.7"			None	N/A	Vegetated Hummocks with Wet Depressions
146	Dr. Adrian Brennan	<i>Saxifraga azoides</i>	29	Sweden; Abisko	530	N 68°19'25.5"	E 018° 50'15.7"			None	N/A	Vegetated Hummocks with Wet Depressions
147	Dr. Adrian Brennan	<i>Saxifraga azoides</i>	29	Sweden; Abisko	530	N 68°19'25.5"	E 018° 50'15.7"			None	N/A	Vegetated Hummocks with Wet Depressions
148	Dr. Adrian Brennan	<i>Saxifraga oppositifolia</i>	29	Sweden; Abisko	530	N 68°19'25.5"	E 018° 50'15.7"			None	N/A	Vegetated Hummocks with Wet Depressions
149	Dr. Adrian Brennan	<i>Saxifraga oppositifolia</i>	29	Sweden; Abisko	530	N 68°19'25.5"	E 018° 50'15.7"			None	N/A	Vegetated Hummocks with Wet Depressions
150	Dr. Adrian Brennan	<i>Saxifraga oppositifolia</i>	29	Sweden; Abisko	530	N 68°19'25.5"	E 018° 50'15.7"			None	N/A	Vegetated Hummocks with Wet Depressions
151	Dr. Adrian Brennan	<i>Saxifraga oppositifolia</i>	29	Sweden; Abisko	530	N 68°19'25.5"	E 018° 50'15.7"			None	N/A	Vegetated Hummocks with Wet Depressions
152	Dr. Adrian Brennan	<i>Empetrum nigrum</i>	30	Sweden; Abisko	510	N 68°19'49.8"	E 018° 50'00.0"			S	N/A	Birch Woodland with <i>Empetrum</i> understorey
153	Dr. Adrian Brennan	<i>Empetrum nigrum</i>	30	Sweden; Abisko	510	N 68°19'49.8"	E 018° 50'00.0"			S	N/A	Birch Woodland with <i>Empetrum</i> understorey
154	Dr. Adrian Brennan	<i>Empetrum nigrum</i>	30	Sweden; Abisko	510	N 68°19'49.8"	E 018° 50'00.0"			S	N/A	Birch Woodland with <i>Empetrum</i> understorey
155	Dr. Adrian Brennan	<i>Empetrum nigrum</i>	31	Sweden; Abisko	510	N 68°19'46.9"	E 018° 50'02.6"			N	N/A	Birch Woodland with <i>Empetrum</i> understorey
156	Dr. Adrian Brennan	<i>Empetrum nigrum</i>	31	Sweden; Abisko	510	N 68°19'46.9"	E 018° 50'02.6"			N	N/A	Birch Woodland with <i>Empetrum</i> understorey
157	Dr. Adrian Brennan	<i>Empetrum nigrum</i>	31	Sweden; Abisko	510	N 68°19'46.9"	E 018° 50'02.6"			N	N/A	Birch Woodland with <i>Empetrum</i> understorey
158	Dr. Adrian Brennan	<i>Empetrum nigrum</i>	32	Sweden; Abisko	250	N 68°29'23.3"	E 017° 45'42.6"			W	N/A	Disturbed gravelly soil

Table 2.1.5k. Table listing details for samples collected as per section 2.1.1. Showing the individual sample code, name of the collector of the sample, species identification (N.B. "?" indicates uncertainty with identification either due to being outside of the expected range or due to altered morphology under extreme environments often combined with limitations of vegetative identification), Site code, general location collected from, altitude (m above sea level), latitude and longitude of the collection site (either in the degrees, minutes, seconds or decimal degrees format) slope and aspect (where present), Soil pH (where recorded) and any additional details recorded.

Sample code	Collector	Species	Site	Location	Altitude (m)	Latitude	Longitude	decimal latitude	decimal longitude	Slope/ aspect	pH	Additional Details
159	Dr. Adrian Brennan	<i>Saxifraga oppositifolia</i>	32	Sweden; Abisko	250	N 68°29'23.3"	E 017° 45'42.6"			W	N/A	Distrubed gravelly soil
160	Dr. Adrian Brennan	<i>Dryas octopetala</i>	33	Sweden; Abisko	1030	N 68°17'09.6"	E 018° 51'52.8"			NE	N/A	Low Vegetation with Bare Rock
161	Dr. Adrian Brennan	<i>Dryas octopetala</i>	33	Sweden; Abisko	1030	N 68°17'09.6"	E 018° 51'52.8"			NE	N/A	Low Vegetation with Bare Rock
162	Dr. Adrian Brennan	<i>Dryas octopetala</i>	33	Sweden; Abisko	1030	N 68°17'09.6"	E 018° 51'52.8"			NE	N/A	Low Vegetation with Bare Rock
163	Dr. Adrian Brennan	<i>Empetrum nigrum</i>	33	Sweden; Abisko	1030	N 68°17'09.6"	E 018° 51'52.8"			NE	N/A	Low Vegetation with Bare Rock
164	Dr. Adrian Brennan	<i>Empetrum nigrum</i>	33	Sweden; Abisko	1030	N 68°17'09.6"	E 018° 51'52.8"			NE	N/A	Low Vegetation with Bare Rock
165	Dr. Adrian Brennan	<i>Empetrum nigrum</i>	33	Sweden; Abisko	1030	N 68°17'09.6"	E 018° 51'52.8"			NE	N/A	Low Vegetation with Bare Rock
166	Dr. Adrian Brennan	<i>Saxifraga oppositifolia</i>	33	Sweden; Abisko	1030	N 68°17'09.6"	E 018° 51'52.8"			NE	N/A	Low Vegetation with Bare Rock
167	Dr. Adrian Brennan	<i>Saxifraga oppositifolia</i>	33	Sweden; Abisko	1030	N 68°17'09.6"	E 018° 51'52.8"			NE	N/A	Low Vegetation with Bare Rock
168	Dr. Adrian Brennan	<i>Saxifraga oppositifolia</i>	33	Sweden; Abisko	1030	N 68°17'09.6"	E 018° 51'52.8"			NE	N/A	Low Vegetation with Bare Rock
169	Alice Rowland	<i>Empetrum nigrum</i>	34	England; North Pennines; Nags Head	645	N 54° 46' 33.3"	W 002° 18' 19.0"			NEE	N/A	
170	Alice Rowland	<i>Vaccinium vitis idea</i>	34	England; North Pennines; Nags Head	645	N 54° 46' 33.3"	W 002° 18' 19.0"			NEE	N/A	
171	Alice Rowland	<i>Rubus chamaemorus</i>	35	England; North Pennines; Nags Head	653	N 54° 46' 37.8"	W 002° 18' 18.9"			S	N/A	
172	Alice Rowland	<i>Rubus chamaemorus</i>	35	England; North Pennines; Nags Head	653	N 54° 46' 37.8"	W 002° 18' 18.9"			S	N/A	
173	Alice Rowland	<i>Calluna vulgaris</i>	35	England; North Pennines; Nags Head	653	N 54° 46' 37.8"	W 002° 18' 18.9"			S	N/A	
174	Alice Rowland	<i>Empetrum nigrum</i>	35	England; North Pennines; Nags Head	653	N 54° 46' 37.8"	W 002° 18' 18.9"			S	N/A	
175	Alice Rowland	<i>Empetrum nigrum</i>	36	England; North Pennines; Long man	533	N 54° 40' 54.1"	W 002° 00' 20.6"			NE	N/A	Mostly Bare Patch

Table 2.1.5I. Table listing details for samples collected as per section 2.1.1. Showing the individual sample code, name of the collector of the sample, species identification (N.B. “?” indicates uncertainty with identification either due to being outside of the expected range or due to altered morphology under extreme environments often combined with limitations of vegetative identification), Site code, general location collected from, altitude (m above sea level), latitude and longitude of the collection site (either in the degrees, minutes, seconds or decimal degrees format) slope and aspect (where present), Soil pH (where recorded) and any additional details recorded.

Sample code	Collector	Species	Site	Location	Altitude (m)	Latitude	Longitude	decimal latitude	decimal longitude	Slope/ aspect	pH	Additional Details
176	Alice Rowland	<i>Vaccinium myrtillus</i>	36	England; North Pennines; Long man	533	N 54° 40' 54.1"	W 002° 00' 20.6"			NE	N/A	Mostly Bare Patch
177	Alice Rowland	<i>Calluna vulgaris</i>	36	England; North Pennines; Long man	533	N 54° 40' 54.1"	W 002° 00' 20.6"			NE	N/A	Mostly Bare Patch
178	Alice Rowland	<i>Calluna vulgaris</i>	38	England; Dartmoor	288	N 50°29'12.5"	W 004° 00'48.9"	50.486806	-4.013583		N/A	
179	Alice Rowland	<i>Calluna vulgaris</i>	39	England; North Pennines; Teesdale	414	N 54°39'02.1"	W 002° 15'52.8"	54.650594	-2.264654		N/A	
180	Alice Rowland	<i>Calluna vulgaris</i>	40	England; North Pennines; Hedleyhope Fell	192	N 54° 46' 12.5"	W 001° 46' 23.3"	54.770139	-1.7731389	NWW	N/A	Steep slope
181	Alice Rowland	<i>Empetrum nigrum</i>	41	England; North Pennines; Hedleyhope Fell	200	N 54° 46' 09.5"	W 001° 46' 28.0"	54.769306	-1.7744444	NWW	N/A	Large overhang, <i>Calluna</i> and <i>Empetrum</i> dangling through
182	Alice Rowland	<i>Calluna vulgaris</i>	41	England; North Pennines; Hedleyhope Fell	200	N 54° 46' 09.5"	W 001° 46' 28.0"	54.769306	-1.7744444	NWW	N/A	Large overhang, <i>Calluna</i> and <i>Empetrum</i> dangling through
183	Alice Rowland	<i>Empetrum nigrum</i>	42	England; North Pennines; Hedleyhope Fell	215	N 54° 46' 01.2"	W 001° 46' 37.8"	54.767	-1.7771667	N	N/A	slight slope, bank of boggy area
184	Alice Rowland	<i>Calluna vulgaris</i>	42	England; North Pennines; Hedleyhope Fell	215	N 54° 46' 01.2"	W 001° 46' 37.8"	54.767	-1.7771667	N	N/A	Slight slope, bank of boggy area
185	Alice Rowland	<i>Calluna vulgaris</i>	43	England; North Pennines; Nenthead Mines	451	N 54° 47' 02.4"	W 002° 20' 17.9"	54.784	-2.3383056	NE	N/A	N/E slope near stream
186	Alice Rowland	<i>Empetrum nigrum</i>	44	Scotland; Cairngorms; Braemar	493.18			56.995007	-3.412244	N	N/A	Rock
187	Alice Rowland	<i>Calluna vulgaris</i>	44	Scotland; Cairngorms; Braemar	493.18			56.995007	-3.412244	N	N/A	Rock
188	Alice Rowland	<i>Empetrum nigrum</i>	45	Scotland; Cairngorms; Braemar; Morrone	497.86			56.994921	-3.412361	W	N/A	Sheltered ledge
189	Alice Rowland	<i>Calluna vulgaris</i>	45	Scotland; Cairngorms; Braemar; Morrone	497.86			56.994921	-3.412361	W	N/A	Sheltered ledge

Table 2.1.5m. Table listing details for samples collected as per section 2.1.1. Showing the individual sample code, name of the collector of the sample, species identification (N.B. “?” indicates uncertainty with identification either due to being outside of the expected range or due to altered morphology under extreme environments often combined with limitations of vegetative identification), Site code, general location collected from, altitude (m above sea level), latitude and longitude of the collection site (either in the degrees, minutes, seconds or decimal degrees format) slope and aspect (where present), Soil pH (where recorded) and any additional details recorded.

Sample code	Collector	Species	Site	Location	Altitude (m)	Latitude	Longitude	decimal latitude	decimal longitude	Slope/ aspect	pH	Additional Details
190	Alice Rowland	<i>Empetrum nigrum</i>	46	Scotland; Cairngorms; Braemar; Morrone	637.26			56.991598	-3.419635		N/A	Exposed rock top (slight E slant for <i>E. nigrum</i> slight W slant for <i>C. vulgaris</i>)
191	Alice Rowland	<i>Calluna vulgaris</i>	46	Scotland; Cairngorms; Braemar; Morrone	637.26			56.991598	-3.419635		N/A	Exposed rock top (slight E slant for <i>E. nigrum</i> slight W slant for <i>C. vulgaris</i>)
192	Alice Rowland	<i>Calluna vulgaris</i>	47	Scotland; Cairngorms; Braemar; Morrone	774.05			56.985393	-3.422861	Flattish	N/A	N side
193	Alice Rowland	<i>Empetrum nigrum</i>	47	Scotland; Cairngorms; Braemar; Morrone	774.05			56.985393	-3.422861	Flattish	N/A	N side
194	Alice Rowland	<i>Calluna vulgaris</i>	48	Scotland; Cairngorms; Braemar; Morrone	850.14			56.981033	-3.4301		N/A	Top of Morrone
195	Alice Rowland	<i>Empetrum nigrum</i>	48	Scotland; Cairngorms; Braemar; Morrone	850.14			56.981033	-3.4301		N/A	Top of Morrone
196	Alice Rowland	<i>Calluna vulgaris</i>	49	Scotland; Cairngorms; Braemar; Morrone	851.88			56.980669	-3.430129		N/A	Top of Morrone
197	Alice Rowland	<i>Empetrum nigrum</i>	49	Scotland; Cairngorms; Braemar; Morrone	851.88			56.980669	-3.430129		N/A	Top of Morrone
198	Alice Rowland	<i>Calluna vulgaris</i>	50	Scotland; Cairngorms; Braemar; Morrone	845.48			56.98008	-3.430013	SW	N/A	
199	Alice Rowland	<i>Empetrum nigrum</i>	50	Scotland; Cairngorms; Braemar; Morrone	845.48			56.98008	-3.430013	SW	N/A	
200	Alice Rowland	<i>Calluna vulgaris</i>	51	Scotland; Cairngorms; Braemar; Morrone	809.38			56.978748	-3.429565	SE	N/A	
201	Alice Rowland	<i>Empetrum nigrum</i>	51	Scotland; Cairngorms; Braemar; Morrone	809.38			56.978748	-3.429565	SE	N/A	
202	Alice Rowland	<i>Calluna vulgaris</i>	52	Scotland; Cairngorms; Braemar; Morrone	706.61			56.975483	-3.426292	E	N/A	Sheltered large "crater" warmer and damper environemt (diff. vegetation obvious)

Table 2.1.5n. Table listing details for samples collected as per section 2.1.1. Showing the individual sample code, name of the collector of the sample, species identification (N.B. “?” indicates uncertainty with identification either due to being outside of the expected range or due to altered morphology under extreme environments often combined with limitations of vegetative identification), Site code, general location collected from, altitude (m above sea level), latitude and longitude of the collection site (either in the degrees, minutes, seconds or decimal degrees format) slope and aspect (where present), Soil pH (where recorded) and any additional details recorded.

Sample code	Collector	Species	Site	Location	Altitude (m)	Latitude	Longitude	decimal latitude	decimal longitude	Slope/ aspect	pH	Additional Details
203	Alice Rowland	<i>Empetrum nigrum</i>	52	Scotland; Cairngorms; Braemar; Morrone	706.61			56.975483	-3.426292	E	N/A	Sheltered large "crater" warmer and damper environemt (diff. vegetation obvious)
204	Alice Rowland	<i>Calluna vulgaris</i>	53	Scotland; Cairngorms; Creag Dubh	408.32			57.037646	-4.18528	S	N/A	Rocky outcrop
205	Alice Rowland		53	Scotland; Cairngorms; Creag Dubh	408.32			57.037646	-4.18528	S	N/A	Rocky outcrop
206	Alice Rowland	<i>Calluna vulgaris</i>	54	Scotland; Cairngorms; Creag Dubh	479.49			57.036996	-4.187389		4.04	Boggy flatland
207	Alice Rowland	<i>Empetrum nigrum</i>	55	Scotland; Cairngorms; Creag Dubh	N/A	N/A	N/A	N/A	N/A	N	N/A	Rock
208	Alice Rowland	<i>Calluna vulgaris</i>	55	Scotland; Cairngorms; Creag Dubh	N/A	N/A	N/A	N/A	N/A	N	N/A	Rock
209	Alice Rowland	<i>Calluna vulgaris</i>	56	Scotland; Cairngorms; Creag Dubh	606.05			57.040812	-4.186332	W	N/A	Rock
210	Alice Rowland	<i>Empetrum nigrum</i>	56	Scotland; Cairngorms; Creag Dubh	606.05			57.040812	-4.186332	W	N/A	Rock
211	Alice Rowland	<i>Calluna vulgaris</i>	57	Scotland; Cairngorms; Creag Dubh	663.65			57.043354	-4.18419		4.22	Top near path
212	Alice Rowland	<i>Empetrum nigrum</i>	57	Scotland; Cairngorms; Creag Dubh	663.65			57.043354	-4.18419		4.22	Top near path
213	Alice Rowland	<i>Calluna vulgaris</i>	58	Scotland; Cairngorms; Ben Macdui	643.55			57.13212	-3.674385	nw	4.08	
214	Alice Rowland	<i>Empetrum nigrum</i>	58	Scotland; Cairngorms; Ben Macdui	643.55			57.13212	-3.674385	nw	4.08	
215	Alice Rowland	<i>Calluna vulgaris</i>	59	Scotland; Cairngorms; Ben Macdui	692.29			57.124714	-3.679581	Slightly N	5.21	
216	Alice Rowland	<i>Empetrum nigrum</i>	59	Scotland; Cairngorms; Ben Macdui	692.29			57.124714	-3.679581	Slightly N	5.21	
217	Alice Rowland	<i>Calluna vulgaris</i>	60	Scotland; Cairngorms; Ben Macdui	757.32			57.120221	-3.683789	v.slightly N	4.22	wet

Table 2.1.5o. Table listing details for samples collected as per section 2.1.1. Showing the individual sample code, name of the collector of the sample, species identification (N.B. “?” indicates uncertainty with identification either due to being outside of the expected range or due to altered morphology under extreme environments often combined with limitations of vegetative identification), Site code, general location collected from, altitude (m above sea level), latitude and longitude of the collection site (either in the degrees, minutes, seconds or decimal degrees format) slope and aspect (where present), Soil pH (where recorded) and any additional details recorded.

Sample code	Collector	Species	Site	Location	Altitude (m)	Latitude	Longitude	decimal latitude	decimal longitude	Slope/ aspect	pH	Additional Details
218	Alice Rowland	<i>Empetrum nigrum</i>	60	Scotland; Cairngorms; Ben Macdui	757.32			57.120221	-3.683789	v. slightly N	4.22	wet
219	Alice Rowland	<i>Calluna vulgaris</i>	61	Scotland; Cairngorms; Ben Macdui	832.84			57.115853	-3.685988	slight N	N/A	
220	Alice Rowland	<i>Empetrum nigrum</i>	61	Scotland; Cairngorms; Ben Macdui	832.84			57.115853	-3.685988	slight N	N/A	
221	Alice Rowland	<i>Calluna vulgaris</i>	62	Scotland; Cairngorms; Ben Macdui	913.42			57.112778	-3.689726	slight N	4.47	
222	Alice Rowland	<i>Empetrum nigrum</i>	62	Scotland; Cairngorms; Ben Macdui	913.42			57.112778	-3.689726	slight N	4.47	
223	Alice Rowland	<i>Empetrum nigrum</i>	63	Scotland; Cairngorms; Ben Macdui	1030.3			57.108391	-3.691205		4.46	Rocky
224	Alice Rowland	<i>Empetrum nigrum</i>	64	Scotland; Cairngorms; Ben Macdui	1089.6			57.09834	-3.690388		4.62	
225	Alice Rowland	<i>Silene acaulis</i>	65	Scotland; Cairngorms; Ben Macdui	1154			57.08474	-3.678577		N/A	Rock top
226	Alice Rowland	<i>Silene acaulis</i>	65	Scotland; Cairngorms; Ben Macdui	1154			57.08474	-3.678577		N/A	Rock top
227	Alice Rowland	<i>Silene acaulis</i>	65	Scotland; Cairngorms; Ben Macdui	1154			57.08474	-3.678577		N/A	Rock top
228	Alice Rowland	<i>Silene acaulis</i>	65	Scotland; Cairngorms; Ben Macdui	1154			57.08474	-3.678577		N/A	Rock top
229	Alice Rowland	<i>Silene acaulis</i>	65	Scotland; Cairngorms; Ben Macdui	1154			57.08474	-3.678577		N/A	Rock top
230	Alice Rowland	<i>Silene acaulis</i>	66	Scotland; Cairngorms; Ben Macdui	1262.2			57.075247	-3.669697		N/A	Rock top
231	Alice Rowland	<i>Silene acaulis</i>	67	Scotland; Cairngorms; Ben Macdui	1303.1			57.070451	-3.669158		4.2	rock top
232	Alice Rowland	<i>Empetrum nigrum</i>	68	Scotland; Cairngorms; Ben Macdui	1100.1			57.112233	-3.654376		N/A	sheltered dip on rock
233	Alice Rowland	<i>Empetrum nigrum</i>	69	Scotland; Cairngorms; Ben Macdui	1103.8			57.112217	-3.654602		N/A	lightly sheltered
234	Alice Rowland	<i>Empetrum nigrum</i>	70	Scotland; Cairngorms; Ben Macdui	912.25			57.121848	-3.660385	slight N/W	4.98	

Table 2.1.5p. Table listing details for samples collected as per section 2.1.1. Showing the individual sample code, name of the collector of the sample, species identification (N.B. “?” indicates uncertainty with identification either due to being outside of the expected range or due to altered morphology under extreme environments often combined with limitations of vegetative identification), Site code, general location collected from, altitude (m above sea level), latitude and longitude of the collection site (either in the degrees, minutes, seconds or decimal degrees format) slope and aspect (where present), Soil pH (where recorded) and any additional details recorded.

Sample code	Collector	Species	Site	Location	Altitude (m)	Latitude	Longitude	decimal latitude	decimal longitude	Slope/ aspect	pH	Additional Details
235	Alice Rowland	<i>Calluna vulgaris</i>	70	Scotland; Cairngorms; Ben Macdui	912.25			57.121848	-3.660385	slight N/W	4.98	
236	Alice Rowland	<i>Calluna vulgaris</i>	71	England; Exmoor; near Minehead	338.36			51.047209	-3.485905	flattish	3.9	
237	Alice Rowland	<i>Erica</i>	71	England; Exmoor; near Minehead	338.36			51.047209	-3.485905	flattish	3.9	
238	Alice Rowland	<i>Calluna vulgaris</i>	72	England; Exmoor; near Minehead	350.8			51.047342	-3.482884	flattish	4.04	
239	Alice Rowland	<i>Calluna vulgaris</i>	73	England; Exmoor; near Minehead	341.06			51.048369	-3.481563	slight N	3.9	
240	Alice Rowland	<i>Calluna vulgaris</i>	74	England; Exmoor; near Minehead	N/A	N/A	N/A	N/A	N/A	N	4.17	
241	Alice Rowland	<i>Calluna vulgaris</i>	75	England; Exmoor; near Minehead	301.01			51.049423	-3.474745	slight N slope	4.13	
242	Alice Rowland	<i>Calluna vulgaris</i>	76	England; Exmoor; near Minehead	322.7			51.046746	-3.475084	flattish	4.32	more gorse and other shrubs present
243	Alice Rowland	<i>Calluna vulgaris</i>	77	England; Exmoor; near Minehead	329.64			51.046761	-3.478684		4.09	
244	Alice Rowland	<i>Calluna vulgaris</i>	78	England; Exmoor; Dunkery Beacon	491.71			51.160928	-3.59412	flattish	4.18	
245	Alice Rowland	<i>Empetrum nigrum</i>	78	England; Exmoor; Dunkery Beacon	491.71			51.160928	-3.59412	flattish	4.18	
246	Alice Rowland	<i>Calluna vulgaris</i>	79	England; Exmoor; Dunkery Beacon	498.85			51.161835	-3.590186	flattish	4.14	
247	Alice Rowland	<i>Empetrum nigrum</i>	79	England; Exmoor; Dunkery Beacon	498.85			51.161835	-3.590186	flattish	4.14	
248	Alice Rowland	<i>Calluna vulgaris</i>	80	England; Exmoor; Dunkery Beacon	517.36			51.162548	-3.586045	flattish	4.15	shallow soil
249	Alice Rowland	<i>Empetrum nigrum</i>	80	England; Exmoor; Dunkery Beacon	517.36			51.162548	-3.586045	flattish	4.15	shallow soil
250	Alice Rowland	<i>Calluna vulgaris</i>	81	England; Exmoor; Dunkery Beacon	476.06			51.163464	-3.578501		4.24	dip near path
251	Alice Rowland	<i>Empetrum nigrum</i>	81	England; Exmoor; Dunkery Beacon	476.06			51.163464	-3.578501		4.24	dip near path

Table 2.1.5q. Table listing details for samples collected as per section 2.1.1. Showing the individual sample code, name of the collector of the sample, species identification (N.B. “?” indicates uncertainty with identification either due to being outside of the expected range or due to altered morphology under extreme environments often combined with limitations of vegetative identification), Site code, general location collected from, altitude (m above sea level), latitude and longitude of the collection site (either in the degrees, minutes, seconds or decimal degrees format) slope and aspect (where present), Soil pH (where recorded) and any additional details recorded.

Sample code	Collector	Species	Site	Location	Altitude (m)	Latitude	Longitude	decimal latitude	decimal longitude	Slope/ aspect	pH	Additional Details
252	Alice Rowland	<i>Calluna vulgaris</i>	82	England; Exmoor; Dunkery Beacon	394.06			51.169812	-3.560574	SE/S	4.22	
253	Alice Rowland	<i>Calluna vulgaris</i>	83	England; Exmoor; Dunkery Beacon	350.83			51.170979	-3.553356	E	4.2	
254	Alice Rowland	<i>Calluna vulgaris</i>	84	England; Exmoor; Dunkery Beacon	336.59			51.172035	-3.55249	NE	4.35	
255	Alice Rowland	<i>Calluna vulgaris</i>	85	England; Exmoor; Dunkery Beacon	356.26			51.174008	-3.555352	NNE	4.02	hard ground pH unreliable
256	Alice Rowland	<i>Calluna vulgaris</i>	86	England; Exmoor; Dunkery Beacon	383.3			51.174429	-3.559254	NNE	3.97	
257	Prof. Annika Hofgaard	<i>Calluna vulgaris</i>	87	Norway; Grødalalen	1000	N/A	N/A	N/A	N/A		N/A	treeline
258	Prof. Annika Hofgaard	<i>Empetrum nigrum</i>	88	Norway; Kongsvoll	1000	N/A	N/A	N/A	N/A		N/A	Forest line
259	Prof. Annika Hofgaard	<i>Phyllodoce caerulea</i>	88	Norway; Kongsvoll	1000	N/A	N/A	N/A	N/A		N/A	Forest line
260	Prof. Annika Hofgaard	<i>Diapensia lapponica</i>	87	Norway; Grødalalen	1000	N/A	N/A	N/A	N/A		N/A	treeline
261	Prof. Annika Hofgaard	<i>Loiseleuria procumbens</i>	88	Norway; Kongsvoll	1000	N/A	N/A	N/A	N/A		N/A	Forest line
262	Prof. Annika Hofgaard	<i>Arctostaphylos uv-ursi</i>	88	Norway; Kongsvoll	1000	N/A	N/A	N/A	N/A		N/A	Forest line
263	Prof. Annika Hofgaard	<i>Arctostaphylos alpina</i>	88	Norway; Kongsvoll	1000	N/A	N/A	N/A	N/A		N/A	Forest line
264	Prof. Annika Hofgaard	<i>Vaccinium myrtillus</i>	88	Norway; Kongsvoll	1000	N/A	N/A	N/A	N/A		N/A	Forest line
265	Prof. Annika Hofgaard	<i>Vaccinium uliginosum</i>	88	Norway; Kongsvoll	1000	N/A	N/A	N/A	N/A		N/A	Forest line
266	Prof. Annika Hofgaard	<i>Vaccinium vitis-idaea</i>	88	Norway; Kongsvoll	1000	N/A	N/A	N/A	N/A		N/A	Forest line
267	Alice Rowland	<i>Calluna vulgaris</i>	89	Scotland; Dumfries and Galloway; Portpatrick	6.7541			54.865224	-5.145795	Slightly NNW	5.78	rock facing out to sea
268	Alice Rowland	<i>Calluna vulgaris</i>	89	Scotland; Dumfries and Galloway; Portpatrick	6.7541			54.865224	-5.145795	Slightly NNW	5.78	rock facing out to sea

Table 2.1.5r. Table listing details for samples collected as per section 2.1.1. Showing the individual sample code, name of the collector of the sample, species identification (N.B. “?” indicates uncertainty with identification either due to being outside of the expected range or due to altered morphology under extreme environments often combined with limitations of vegetative identification), Site code, general location collected from, altitude (m above sea level), latitude and longitude of the collection site (either in the degrees, minutes, seconds or decimal degrees format) slope and aspect (where present), Soil pH (where recorded) and any additional details recorded.

Sample code	Collector	Species	Site	Location	Altitude (m)	Latitude	Longitude	decimal latitude	decimal longitude	Slope/ aspect	pH	Additional Details
269	Alice Rowland	<i>Calluna vulgaris</i>	90	Scotland; Dumfries and Galloway; Portpatrick	3.7428			54.866653	-5.144319	SW	N/A	SW facing rock sheltered from sea by larger rock
270	Alice Rowland	<i>Calluna vulgaris</i>	91	Scotland; Dumfries and Galloway; Portpatrick	6.7122			54.867877	-5.144627	slight SW	4.92	rock facing out to sea
271	Alice Rowland	<i>Calluna vulgaris</i>	92	Scotland; Dumfries and Galloway; Portpatrick	5.7			54.868093	-5.144428	NNW	N/A	rock
272	Alice Rowland	<i>Calluna vulgaris</i>	93	Scotland; Dumfries and Galloway; Portpatrick	22.91			54.862023	-5.14468	W	4.92	
273	Alice Rowland	<i>Calluna vulgaris</i>	94	Scotland; Dumfries and Galloway; Portpatrick	23.511			54.857729	-5.141591	SW	3.99	
274	Alice Rowland	<i>Calluna vulgaris</i>	95	Scotland; Dumfries and Galloway; Portpatrick	50.827			54.853987	-5.137544	NE	3.98	
275	Alice Rowland	<i>Calluna vulgaris</i>	96	Scotland; Dumfries and Galloway; Portpatrick	44.381			54.853513	-5.137316	NW	N/A	rock
276	Alice Rowland	<i>Calluna vulgaris</i>	97	Scotland; Dumfries and Galloway; Portpatrick	22.305			54.851351	-5.133886	NNE	5.19	sheltered area with overhang
277	Alice Rowland	<i>Empetrum nigrum</i>	97	Scotland; Dumfries and Galloway; Portpatrick	22.305			54.851351	-5.133886	NNE	5.19	sheltered area with overhang
278	Alice Rowland	<i>Calluna vulgaris</i>	98	Scotland; Dumfries and Galloway; Portpatrick	5.7649			54.851304	-5.130704	W	4.48	
279	Alice Rowland	<i>Calluna vulgaris</i>	99	Scotland; Dumfries and Galloway; Portpatrick	8.8097			54.850459	-5.128882	NW	5.49	
280	Alice Rowland	<i>Calluna vulgaris</i>	100	Scotland; Galloway; Glen Trool	136.37			55.080224	-4.525737	SW	3.82	iron rich rock
281	Alice Rowland	<i>Calluna vulgaris</i>	101	Scotland; Galloway; Glen Trool	105.64			55.081918	-4.519367		4.84	slope birch understory by path - tall plant
282	Alice Rowland	<i>Calluna vulgaris</i>	102	Scotland; Galloway; Glen Trool	92.189			55.073593	-4.512777	W	N/A	rock
283	Alice Rowland	<i>Calluna vulgaris</i>	103	Scotland; Galloway; Glen Trool	64.669			55.0762	-4.516981		3.79	ditch near path, birch understory
284	Alice Rowland	<i>Calluna vulgaris</i>	104	Scotland; Galloway; Glen Trool	65.885			55.075843	-4.518165		4.63	near black pond

Table 2.1.5s. Table listing details for samples collected as per section 2.1.1. Showing the individual sample code, name of the collector of the sample, species identification (N.B. “?” indicates uncertainty with identification either due to being outside of the expected range or due to altered morphology under extreme environments often combined with limitations of vegetative identification), Site code, general location collected from, altitude (m above sea level), latitude and longitude of the collection site (either in the degrees, minutes, seconds or decimal degrees format) slope and aspect (where present), Soil pH (where recorded) and any additional details recorded.

Sample code	Collector	Species	Site	Location	Altitude (m)	Latitude	Longitude	decimal latitude	decimal longitude	Slope/ aspect	pH	Additional Details
285	Alice Rowland	<i>Calluna vulgaris</i>	105	Scotland; Galloway; Glen Trool	N/A	N/A	N/A	N/A	N/A		N/A	under pine
286	Alice Rowland	<i>Calluna vulgaris</i>	106	Scotland; Galloway; Glen Trool	67.07			55.071041	-4.541832		4.42	near river
287	Alice Rowland	<i>Calluna vulgaris</i>	107	England; Yorkshire; Moors near Fylindales	212.78			54.430163	-0.570075		N/A	
288	Alice Rowland	<i>Empetrum nigrum</i>	108	England; Yorkshire; Moors near Fylindales	212.69			54.430226	-0.570282		N/A	
289	Alice Rowland	<i>Calluna vulgaris</i>	109	England; Yorkshire; Moors near Fylindales	210.44			54.431404	-0.571897		N/A	
290	Alice Rowland	<i>Empetrum nigrum</i>	109	England; Yorkshire; Moors near Fylindales	210.44			54.431404	-0.571897		N/A	
291	Alice Rowland	<i>Calluna vulgaris</i>	110	England; Yorkshire; Moors near Fylindales	209.45			54.43299	-0.572405		N/A	regenerating burn
292	Alice Rowland	<i>Empetrum nigrum</i>	110	England; Yorkshire; Moors near Fylindales	209.45			54.43299	-0.572405		N/A	regenerating burn
293	Alice Rowland	<i>Calluna vulgaris</i>	111	England; Yorkshire; Eskdaleside cum Ugglebarnby	191.9			54.440159	-0.667083		3.98	
294	Alice Rowland	<i>Empetrum nigrum</i>	111	England; Yorkshire; Eskdaleside cum Ugglebarnby	191.9			54.440159	-0.667083		3.98	
295	Alice Rowland	<i>Empetrum nigrum</i>	112	England; Yorkshire; Eskdaleside cum Ugglebarnby	194.37			54.441189	-0.66966	NNW	3.62	hollow
296	Alice Rowland	<i>Calluna vulgaris</i>	112	England; Yorkshire; Eskdaleside cum Ugglebarnby	194.37			54.441189	-0.66966	NNW	3.62	hollow
297	Alice Rowland	<i>Empetrum nigrum</i>	113	England; Yorkshire; Eskdaleside cum Ugglebarnby	212.33			54.439667	-0.676668	slightly N	3.72	
298	Alice Rowland	<i>Calluna vulgaris</i>	113	England; Yorkshire; Eskdaleside cum Ugglebarnby	212.33			54.439667	-0.676668	slightly N	3.72	

Table 2.1.5t. Table listing details for samples collected as per section 2.1.1. Showing the individual sample code, name of the collector of the sample, species identification (N.B. “?” indicates uncertainty with identification either due to being outside of the expected range or due to altered morphology under extreme environments often combined with limitations of vegetative identification), Site code, general location collected from, altitude (m above sea level), latitude and longitude of the collection site (either in the degrees, minutes, seconds or decimal degrees format) slope and aspect (where present), Soil pH (where recorded) and any additional details recorded.

Sample code	Collector	Species	Site	Location	Altitude (m)	Latitude	Longitude	decimal latitude	decimal longitude	Slope/ aspect	pH	Additional Details
299	Alice Rowland	<i>Calluna vulgaris</i>	114	England; Yorkshire; Eskdaleside cum Ugglebarnby	250.61			54.439241	-0.686467		3.94	
300	Alice Rowland	<i>Calluna vulgaris</i>	114	England; Yorkshire; Eskdaleside cum Ugglebarnby	250.61			54.439241	-0.686467		3.94	
301	Alice Rowland	<i>Calluna vulgaris</i>	115	England; Yorkshire; Moors near Hutton-le-Hole	197.54			54.316042	-0.930714		4.01	
302	Alice Rowland	<i>Empetrum nigrum</i>	115	England; Yorkshire; Moors near Hutton-le-Hole	197.54			54.316042	-0.930714		4.01	
303	Alice Rowland	<i>Calluna vulgaris</i>	116	England; Yorkshire; Moors near Hutton-le-Hole	196.14			54.315984	-0.930004		3.91	regenerating burn
304	Alice Rowland	<i>Empetrum nigrum</i>	116	England; Yorkshire; Moors near Hutton-le-Hole	196.14			54.315984	-0.930004		3.91	regenerating burn
305	Alice Rowland	<i>Calluna vulgaris</i>	117	England; Yorkshire; Moors near Hutton-le-Hole	144.85			54.315566	-0.923258	W	3.91	near stream
306	Alice Rowland	<i>Calluna vulgaris</i>	118	England; Yorkshire; Moors near Hutton-le-Hole	144.76			54.315442	-0.923008	W	N/A	further from stream
307	Alice Rowland	<i>Empetrum nigrum</i>	118	England; Yorkshire; Moors near Hutton-le-Hole	144.76			54.315442	-0.923008	W	N/A	further from stream
308	Alice Rowland	<i>Calluna vulgaris</i>	119	England; Yorkshire; Moors near Hutton-le-Hole	151.66			54.315586	-0.921248		4.08	
309	Alice Rowland	<i>Calluna vulgaris</i>	120	England; Yorkshire; Moors near Hutton-le-Hole	158.99			54.315765	-0.919813		N/A	thick billberry patch
310	Alice Rowland	<i>Empetrum nigrum</i>	120	England; Yorkshire; Moors near Hutton-le-Hole	158.99			54.315765	-0.919813		N/A	thick billberry patch
311	Alice Rowland	<i>Calluna vulgaris</i>	121	England; Yorkshire; Moors near Hutton-le-Hole	216.56			54.323427	-0.916739		3.63	
312	Alice Rowland	<i>Calluna vulgaris</i>	122	England; Yorkshire; Moors near Hutton-le-Hole	219.13			54.32382	-0.916636		3.67	
313	Alice Rowland	<i>Empetrum nigrum</i>	122	England; Yorkshire; Moors near Hutton-le-Hole	219.13			54.32382	-0.916636		3.67	
314	Alice Rowland	<i>Calluna vulgaris</i>	123	England; Yorkshire; Moors near Hutton-le-Hole	264.18			54.331656	-0.917853		4.04	

Table 2.1.5u. Table listing details for samples collected as per section 2.1.1. Showing the individual sample code, name of the collector of the sample, species identification (N.B. “?” indicates uncertainty with identification either due to being outside of the expected range or due to altered morphology under extreme environments often combined with limitations of vegetative identification), Site code, general location collected from, altitude (m above sea level), latitude and longitude of the collection site (either in the degrees, minutes, seconds or decimal degrees format) slope and aspect (where present), Soil pH (where recorded) and any additional details recorded.

Sample code	Collector	Species	Site	Location	Altitude (m)	Latitude	Longitude	decimal latitude	decimal longitude	Slope/ aspect	pH	Additional Details
315	Alice Rowland	<i>Calluna vulgaris</i>	124	England; Yorkshire; Moors near Hutton-le-Hole	270.95			54.334102	-0.918089		3.82	over knee high plant
316	Alice Rowland	<i>Calluna vulgaris</i>	125	England; Yorkshire; Moors near Hutton-le-Hole	314.56			54.341785	-0.921009		3.75	Boggy
317	Alice Rowland	<i>Empetrum nigrum</i>	126	England; Yorkshire; Moors near Hutton-le-Hole	316.78			54.341925	-0.921397		N/A	
318	Dr. Johan Olofsson	<i>Calluna vulgaris</i>	N/A	N/A	N/A	N/A	N/A	N/A	N/A	N/A	N/A	
319	Dr. Johan Olofsson	<i>Rhododendron lapponum</i>	N/A	N/A	N/A	N/A	N/A	N/A	N/A	N/A	N/A	
320	Dr. Johan Olofsson	<i>Andromeda polifolia</i>	N/A	N/A	N/A	N/A	N/A	N/A	N/A	N/A	N/A	
321	Dr. Johan Olofsson	<i>Empetrum hermaphroditum</i>	N/A	N/A	N/A	N/A	N/A	N/A	N/A	N/A	N/A	
322	Dr. Johan Olofsson	<i>Arctostaphylus alpinus</i>	N/A	N/A	N/A	N/A	N/A	N/A	N/A	N/A	N/A	
323	Dr. Johan Olofsson	<i>Phyllodoce caerulea</i>	N/A	N/A	N/A	N/A	N/A	N/A	N/A	N/A	N/A	
324	Dr. Johan Olofsson	<i>Cassiope tetragona</i>	N/A	N/A	N/A	N/A	N/A	N/A	N/A	N/A	N/A	
325	Dr. Johan Olofsson	<i>Loiseleuria procumbens</i>	N/A	N/A	N/A	N/A	N/A	N/A	N/A	N/A	N/A	
326	Dr. Johan Olofsson	<i>Pyrula minor</i>	N/A	N/A	N/A	N/A	N/A	N/A	N/A	N/A	N/A	
327	Alice Rowland	<i>Calluna vulgaris</i>	128	Wales; Brecon Beacons	408.32			51.85496	-3.468621	SW slope	5.53	Roadsided
328	Alice Rowland	<i>Calluna vulgaris</i>	129	Wales; Brecon Beacons	468.7			51.868522	-3.467467	W	4.1	
329	Alice Rowland	<i>Calluna vulgaris</i>	130	Wales; Brecon Beacons	496.06			51.869194	-3.464969	W	4.44	Near path
330	Alice Rowland	<i>Calluna vulgaris</i>	131	Wales; Brecon Beacons	593.08			51.878613	-3.457791	N	N/A	cliff edge by stream
331	Alice Rowland	<i>Calluna vulgaris</i>	132	Wales; Brecon Beacons	667.81			52.021619	-3.104595	Slight W	3.74	
332	Alice Rowland	<i>Empetrum nigrum</i>	132	Wales; Brecon Beacons	667.81			52.021619	-3.104595	Slight W	3.74	

Table 2.1.5v. Table listing details for samples collected as per section 2.1.1. Showing the individual sample code, name of the collector of the sample, species identification (N.B. “?” indicates uncertainty with identification either due to being outside of the expected range or due to altered morphology under extreme environments often combined with limitations of vegetative identification), Site code, general location collected from, altitude (m above sea level), latitude and longitude of the collection site (either in the degrees, minutes, seconds or decimal degrees format) slope and aspect (where present), Soil pH (where recorded) and any additional details recorded.

Sample code	Collector	Species	Site	Location	Altitude (m)	Latitude	Longitude	decimal latitude	decimal longitude	Slope/ aspect	pH	Additional Details
333	Alice Rowland	<i>Calluna vulgaris</i>	133	Wales; Brecon Beacons	670.4			52.022082	-3.103914		3.65	
334	Alice Rowland	<i>Empetrum nigrum</i>	133	Wales; Brecon Beacons	670.4			52.022082	-3.103914		3.65	
335	Alice Rowland	<i>Calluna vulgaris</i>	134	Wales; Brecon Beacons	672.82			52.022882	-3.101938		3.58	
336	Alice Rowland	<i>Empetrum nigrum</i>	134	Wales; Brecon Beacons	672.82			52.022882	-3.101938		3.58	
337	Alice Rowland	<i>Calluna vulgaris</i>	135	Wales; Brecon Beacons	663.79			52.019552	-3.096422		3.54	
338	Alice Rowland	<i>Calluna vulgaris</i>	136	Wales; Brecon Beacons	662.18			52.018906	-3.095584		3.88	
339	Alice Rowland	<i>Empetrum nigrum</i>	136	Wales; Brecon Beacons	662.18			52.018906	-3.095584		3.88	
340	Alice Rowland	<i>Calluna vulgaris</i>	137	Wales; Brecon Beacons	692.49			52.015125	-3.088687		3.54	
341	Alice Rowland	<i>Empetrum nigrum</i>	137	Wales; Brecon Beacons	692.49			52.015125	-3.088687		3.54	
342	Alice Rowland	<i>Calluna vulgaris</i>	138	Wales; Brecon Beacons	700.32			52.00855	-3.08601		3.66	patchy landscape
343	Alice Rowland	<i>Empetrum nigrum</i>	138	Wales; Brecon Beacons	700.32			52.00855	-3.08601		3.66	patchy landscape
344	Alice Rowland	<i>Calluna vulgaris</i>	139	Wales; Brecon Beacons	663.27			51.997474	-3.076552		3.92	
345	Alice Rowland	<i>Empetrum nigrum</i>	139	Wales; Brecon Beacons	663.27			51.997474	-3.076552		3.92	
346	Alice Rowland	<i>Calluna vulgaris</i>	140	Wales; Brecon Beacons	623.05			51.989496	-3.070013		3.63	
347	Alice Rowland	<i>Empetrum nigrum</i>	140	Wales; Brecon Beacons	623.05			51.989496	-3.070013		3.63	
348	Alice Rowland	<i>Calluna vulgaris</i>	141	Wales; Brecon Beacons	482.81			51.982589	-3.093898		N/A	
349	Alice Rowland	<i>Calluna vulgaris</i>	132	Wales; Brecon Beacons	667.81			52.021619	-3.104595	Slight W	3.74	
350	Alice Rowland	<i>Empetrum nigrum</i>	132	Wales; Brecon Beacons	667.81			52.021619	-3.104595	Slight W	3.74	
351	Alice Rowland	<i>Calluna vulgaris</i>	143	Wales; Brecon Beacons	661.66			51.997794	-3.109974		3.69	
352	Alice Rowland	<i>Empetrum nigrum</i>	143	Wales; Brecon Beacons	661.66			51.997794	-3.109974		3.69	
353	Alice Rowland	<i>Empetrum nigrum</i>	144	England; Derbyshire; Bealey Moor	N/A	N/A	N/A	N/A	N/A		3.91	woodland near road

Table 2.1.5w. Table listing details for samples collected as per section 2.1.1. Showing the individual sample code, name of the collector of the sample, species identification (N.B. “?” indicates uncertainty with identification either due to being outside of the expected range or due to altered morphology under extreme environments often combined with limitations of vegetative identification), Site code, general location collected from, altitude (m above sea level), latitude and longitude of the collection site (either in the degrees, minutes, seconds or decimal degrees format) slope and aspect (where present), Soil pH (where recorded) and any additional details recorded.

Sample code	Collector	Species	Site	Location	Altitude (m)	Latitude	Longitude	decimal latitude	decimal longitude	Slope/ aspect	pH	Additional Details
354	Alice Rowland	<i>Calluna vulgaris</i>	144	England; Derbyshire; Bealey Moor	N/A	N/A	N/A	N/A	N/A		3.91	woodland near road
355	Alice Rowland	<i>Calluna vulgaris</i>	145	England; Derbyshire; Bealey Moor	322.91			53.216389	-1.538042		3.98	flattish
356	Alice Rowland	<i>Calluna vulgaris</i>	146	England; Derbyshire; Bealey Moor	323.07			53.216359	-1.538876		3.58	on tussock
357	Alice Rowland	<i>Empetrum nigrum</i>	146	England; Derbyshire; Bealey Moor	323.07			53.216359	-1.538876		3.58	on tussock
358	Alice Rowland	<i>Calluna vulgaris</i>	147	England; Derbyshire; Bealey Moor	N/A	N/A	N/A	N/A	N/A	mild SSW slope	3.98	knee high
359	Alice Rowland	<i>Calluna vulgaris</i>	148	England; Derbyshire; Bealey Moor	318.55			53.215186	-1.541475	slight NNE	3.85	
360	Alice Rowland	<i>Empetrum nigrum</i>	149	England; Derbyshire; Bealey Moor	327.33			53.214914	-1.544077		4	Possible burn site
361	Alice Rowland	<i>Calluna vulgaris</i>	149	England; Derbyshire; Bealey Moor	327.33			53.214914	-1.544077		4	Possible burn site
362	Alice Rowland	<i>Calluna vulgaris</i>	150	England; Derbyshire; Bealey Moor	333.97			53.214604	-1.549234		3.91	
363	Alice Rowland	<i>Empetrum nigrum</i>	150	England; Derbyshire; Bealey Moor	333.97			53.214604	-1.549234		3.91	
364	Alice Rowland	<i>Calluna vulgaris</i>	151	England; Derbyshire; Bealey Moor	358.79			53.213578	-1.555351		3.83	
365	Alice Rowland	<i>Calluna vulgaris</i>	152	England; Derbyshire; Bealey Moor	294.3			53.212275	-1.580897		N/A	little hillock
366	Alice Rowland	<i>Calluna vulgaris</i>	153	England; Derbyshire; Bealey Moor	292.24			53.213007	-1.581507		3.85	centre of stone circle
367	Alice Rowland	<i>Calluna vulgaris</i>	154	England; Derbyshire; Bealey Moor	513.44			53.434909	-1.867804		3.48	
368	Alice Rowland	<i>Empetrum nigrum</i>	154	England; Derbyshire; Bealey Moor	513.44			53.434909	-1.867804		3.48	
369	Alice Rowland	<i>Empetrum nigrum</i>	155	England; Derbyshire; Bealey Moor	556.51			53.44463	-1.854526		3.56	

Table 2.1.5x. Table listing details for samples collected as per section 2.1.1. Showing the individual sample code, name of the collector of the sample, species identification (N.B. “?” indicates uncertainty with identification either due to being outside of the expected range or due to altered morphology under extreme environments often combined with limitations of vegetative identification), Site code, general location collected from, altitude (m above sea level), latitude and longitude of the collection site (either in the degrees, minutes, seconds or decimal degrees format) slope and aspect (where present), Soil pH (where recorded) and any additional details recorded.

Sample code	Collector	Species	Site	Location	Altitude (m)	Latitude	Longitude	decimal latitude	decimal longitude	Slope/ aspect	pH	Additional Details
370	Alice Rowland	<i>Empetrum nigrum</i>	156	England; Derbyshire; Bealey Moor	560.7			53.448028	-1.862098		3.44	
371	Alice Rowland	<i>Calluna vulgaris</i>	157	England; Derbyshire; Bealey Moor	605.36			53.448856	-1.86733		4.09	
372	Alice Rowland	<i>Empetrum nigrum</i>	158	England; Derbyshire; Bealey Moor	606.73			53.450676	-1.86459		3.38	
373	Alice Rowland	<i>Calluna vulgaris</i>	158	England; Derbyshire; Bealey Moor	606.73			53.450676	-1.86459		3.38	
374	Alice Rowland	<i>Calluna vulgaris</i>	159	England; Derbyshire; Bealey Moor	601.63			53.452622	-1.862828		3.59	
375	Alice Rowland	<i>Empetrum nigrum</i>	159	England; Derbyshire; Bealey Moor	601.63			53.452622	-1.862828		3.59	
376	Alice Rowland	<i>Calluna vulgaris</i>	160	England; Derbyshire; Bealey Moor	613.78			53.458049	-1.859905		3.67	
377	Alice Rowland	<i>Empetrum nigrum</i>	160	England; Derbyshire; Bealey Moor	613.78			53.458049	-1.859905		3.67	
378	Alice Rowland	<i>Empetrum nigrum</i>	161	England; Derbyshire; Bealey Moor	625.59			53.461137	-1.860756		4.75	
379	Alice Rowland	<i>Calluna vulgaris</i>	161	England; Derbyshire; Bealey Moor	625.59			53.461137	-1.860756		4.75	

2.2 Live Test Species Selection and Growth Conditions

2.2.1 Selection and Growth of Alpine Model Plants

2.2.1.1 Selection Criteria

Different geographic locations experience different seasonal day/night cycles, freezing extremes and frequency. Therefore genetic, molecular and physiological study of different populations of the same species in different geographic locations may aid in elucidating the mechanisms involved in freezing tolerance, especially where differences are seen. Hence a study species which could be grown in controlled conditions from seed collected from different locations was required. A requirements shortlist was constructed to aid in selection of such a species (see below) and species distributions were checked in Encyclopaedia of Life (EOL, 2014) and Global Biodiversity Information Facility (Global Biodiversity Information Facility). The shortlist of species which met these requirements to be taken for further tests consisted of *Dianthus superbus*, *Dryas octopetala*, *Gentiana verna*, *Minuartia verna*, *Saxifraga azoides* and *Saxifraga oppositifolia*. Initially horticultural seed was used to assess germination ease and rate, growth rate, ability to force under glass and, in some cases such as *Dianthus superbus*, freezing tolerance.

Required criteria:

- Overwinters above ground
- Good freezing tolerance
- Hermaphroditic or monoecious
- No incompatibility systems
- Wide distribution covering different temperatures and day/night cycles

Preferred criteria:

- Rapid growth rate
- Rapid seed set
- Able to force, under glass
- Fast germination rate possible to induce
- Vegetative propagation possible
- Molecular literature available
- Horticultural seed for initial tests available

2.2.1.2 Germination and Growth Media

Each species had a specific soil requirement which was kept consistent for both germination and growth: *Dianthus superbus* - 4 parts John Innes seed compost to 1 parts horticultural sand. *Dryas octopetala* - 1 parts John Innes seed compost to 2 parts horticultural sand, *Gentiana verna* - 5 parts John Innes seed compost to 1 part horticultural sand, *Minuartia verna* - John Innes seed compost only and *Saxifraga azoides* & *Saxifraga oppositifolia* - equal parts John Innes seed compost to horticultural sand. These substrate requirements were estimated to provide the desired degree on drainage using descriptions of preferred growth media from the following online-sources for each species: *Dianthus superbus* (Seedaholic.com), *Dryas octopetala* (GardenersHQ.com, Alpiner, 2005), *Gentiana verna* (Upward, RHS) *Minuartia verna* (BluestonePerennials), *Saxifraga* (McGregor).

2.2.1.3 Germination Conditions

Seeds for preliminary tests were ordered from Jelitto Perennial Seeds, St Ives, Huntingdon, Cambridgeshire. Initially all seeds were soaked in 1 mM GA₃ overnight prior to sowing. This was then switched to 0.3 mM GA₄₊₇ for all seeds except *Dianthus*

superbus which was switched to sowing directly, due to previously displayed rapid germination. Seeds were sown in half seed trays in the appropriate media (see 2.7.2) with a basal gravel filling. Trays were then placed in large bags to keep humidity high. After the first attempt *Dryas octopetalla* seeds were sown in tall pots instead of trays due to the observed very early development of long roots for which seed trays were not sufficiently deep. Once sown seed trays/pots were placed in a growth chamber (Weiss Gallenkamp, Loughborough, UK) set at 20 °C, 70 % humidity, 18h day length with 600 $\mu\text{mol m}^{-2} \text{s}^{-1}$ light with a one hour sunrise and one hour sunset of 300 $\mu\text{mol m}^{-2}\text{s}^{-1}$ and supplemental red light from tungsten lamps during programmed daylight hours.

2.2.1.4 Growth Conditions of Seedlings

Once germinated, the growth temperature was altered to 16 °C during daylight hours, 15 °C during simulated sunrise and sunset and 14 °C during the night. All other chamber settings remained the same as during germination. Upon reaching first true leaves plants were potted on and pots placed in plunge beds made from horticultural sand to keep roots cool, humidity high and provide a consistent supply of moisture.

2.2.2 Growth of *Empetrum nigrum* and *Calluna vulgaris* From Cuttings

2.2.2.1 Conditions

Cuttings were, when possible, grown in a growth chamber (Weiss Gallenkamp, Loughborough, UK) set at 16 °C during simulated daylight hours dropping to 14 °C over night, 70 % humidity, 16h day length with 600 $\mu\text{mol m}^{-2} \text{s}^{-1}$ light with a one hour sunrise and one hour sunset of 300 $\mu\text{mol m}^{-2}\text{s}^{-1}$ and supplemental red light from tungsten lamps during programmed daylight hours.

During frequent multiple mechanical failures of the growth chambers and long periods of downtime, plants from rooted cuttings experienced a variety of temperatures, a maximum of around 35 °C during some failures which resulted in the loss of a number of samples. Whilst awaiting repair to these facilities, plants went into a variety of non-controlled conditions including outdoor conditions (spring/summer) and greenhouse conditions (with seasonal dependant lighting). A datalogger tracked the temperature changes.

2.2.2.2 Rooting of Cuttings

The best method of rooting of cuttings of the selected species of interest, *Empetrum nigrum* and *Calluna vulgaris*, was investigated. Numerous cuttings from Nags Head, North Pennines, UK were collected. These cuttings included a mix of sizes and tissue ages including cuttings consisting of only this season's growth and those with older, more woody tissue. Several rooting methods were then attempted. Both species from a mixture of locations and cutting types were used for each rooting method (unless otherwise stated) and all cuttings had several leaves stripped back leaving just a few leaves remaining which remained above the substrate. The methods attempted were as follows:

- Planting in peat-plugs (Jiffy Products, International AS, Norway);
- Planting in sand;
- Planting in John Innes seed compost;
- Immersion in de-ionised water in 50 ml falcon tubes;
- Placed horizontally on damp filter paper in petri-dishes (only cuttings of woody tissue that was found growing horizontally in the wild were used in these tests).

After initial tests, rooting in falcon tubes with de-ionised water was chosen as the optimal rooting method and used for all further rooting of cuttings.

Upon the visible development of a root system with greater than two roots or branches and at a length greater than 250 mm rooted cuttings were potted up into black sphagnum peat in 90 mm diameter pots, the wet roots were dipped into Empathy Rootgrow Ericoid Mycorrhizal fungi which was also sprinkled into the planting hole prior to the addition of further peat. Pots were then well watered and returned to standard growing conditions (Section 2.2.2.1).

Due to limited availability of space, the maximum size pot for plants was 90 mm diameter, therefore upon testing, all samples were heavily pot-bound. However, this was consistent across all samples.

2.2.3 *Nicotiana benthamiana* Growth Conditions

Nicotiana benthamiana plants were grown in temperature controlled rooms at 25 °C with 12 hours daylight 12 hours night cycle with a light intensity of 250-300 $\mu\text{mol m}^{-2} \text{sec}^{-1}$.

2.2.4 Growth of *Arabidopsis thaliana*

Wildtype line Col-0 of *Arabidopsis thaliana* was used for all transformations and wildtype controls. All *Arabidopsis thaliana* were grown at 20 °C with a light intensity of 150 $\mu\text{mol m}^{-2} \text{s}^{-1}$ with varying day/night cycles.

2.2.4.1 MS Media

Murashige and Skoog (MS) media was added at a ratio of 4.3 g per litre to MilliQ water. This was increased to a pH of 5.8 using KOH, then added to Sigma plant agar at a ratio of 8 g L⁻¹. This was then autoclaved for 20 minutes at 121 °C at 105 Pa. Once hand-hot, the antibiotics Timentin at 200 $\mu\text{g ml}^{-1}$ and Hygromycin at 50 $\mu\text{g ml}^{-1}$ were added if required and then poured into petri dishes (of varying size, dependant upon experiment).

2.2.4.2 Seed Sterilisation

Two methods of seed surface sterilisation were used for growth of *Arabidopsis thaliana* seeds: short seed sterilisation for wildtype and established lines and long seed sterilisation for seeds collected from transformed plants.

Short seed sterilisation: Seeds (max. volume of approx. 150 μ l) were shaken in a 1.5 ml Eppendorf filled with 70 % ethanol for 5 minutes, before being left to dry on filter paper in a Microflow Horizontal Laminar flowhood. Once dried, seeds were either stored or plated out.

Long seed sterilisation: 50 ml Falcon tubes containing seeds to be sterilised were filled with 70 % ethanol and shaken for 5 minutes. The ethanol was then decanted and a mixture containing 0.25 % (w/v) sodium dodecyl sulphate (SDS) and 10 % (v/v) sodium hypochlorite in sterile (autoclaved, reverse osmosis filtered) water was added. Tubes were then shaken for 10 minutes. This mixture was then decanted and the seeds washed in sterile water. This washing step was repeated seven times. Seeds were then resuspended in a volume of water approximately twice the volume of the seeds, and then plated out.

Upon surface sterilisation, seeds were sprinkled (short sterilisation) or pipetted (long sterilisation) onto MS Agar plates (section 2.2.4.1). For selection of seeds from transformed plants, plates containing the antibiotics 200 μ g ml⁻¹ Timentin and 50 μ g ml⁻¹ Hygromycin were used. These plates were then placed in the dark at 4 °C for a minimum of 48 hours before transferal to germination conditions (Section 2.2.4.3)

2.2.4.3 Germination and Growth

Seeds were germinated on MS agar plates in a 16 h day 8 h night cycle in a Plant Climatics Percival CU-3615D.

Once seedlings had reached an appropriate size on plates (approx. at 7-10 days for wild type) or were showing distinction from non-transformed seeds on selection plates, seedlings were transferred to re-hydrated sterile 44 mm peat plugs (Jiffy Products, International AS, Norway) at a ratio of 1 seedling per plug for experiments and bulking of seed and 3 seedlings per plug for dipping.

Seedlings were then transferred to a 12 hour day 12 hour night cycle at 100 % humidity (by covering with plastic) for 24 hours, humidity was then reduced (by partial removal of plastic covering) for a further 24 hours before complete removal of the plastic covering. Upon approaching mature plant size, or displaying evidence of the formation of flower primordia, plants were transferred to a 16 h day 8 h night cycle.

10 days prior to dipping, plants for dipping had the flower bolts trimmed to a few millimetres above the surface of the rosette.

2.2.4.4 GA₃ stock for topical application

Some *Arabidopsis thaliana* plants transformed to overexpress synthetic *CBF* genes (Section 2.8.11) showed extreme dwarfism, a topical application of GA₃ was applied to these plants to assist growth. A 20 mM stock of GA₃ (in ethanol) was produced and then diluted in water to produce a 100 µM solution. This solution was then applied to plants displaying extreme dwarfism via a soft bristled paintbrush.

2.3 Freezing and Chilling Treatments for Live Samples

2.3.1 *Empetrum nigrum* Chilling Time-course for qPCR

Empetrum nigrum plants to undergo chilling for tissue collection for RNA extraction for qPCR, after growth as per section 2.2.2.1, were subjected to a period of chilling at 5 °C in growth chambers (Weiss Gallenkamp, Loughborough, UK). Tissue was sampled at 0,

2, 4, 8, 14 and 24 hours as per Figure 2.3.1.1 then frozen in liquid nitrogen and stored at -80 °C.

5 °C was chosen as a low, but non-freezing, temperature to attempt induce acclimation and *CBF* expression. This is the standard chilling temperature used in the Knight lab for inducing *CBF* expression in *Arabidopsis thaliana*. Since there is no knowledge on the temperature required to induce *CBF* expression in *Empetrum nigrum*, and a temperature above freezing was desired for initial tests, 5 °C was selected.

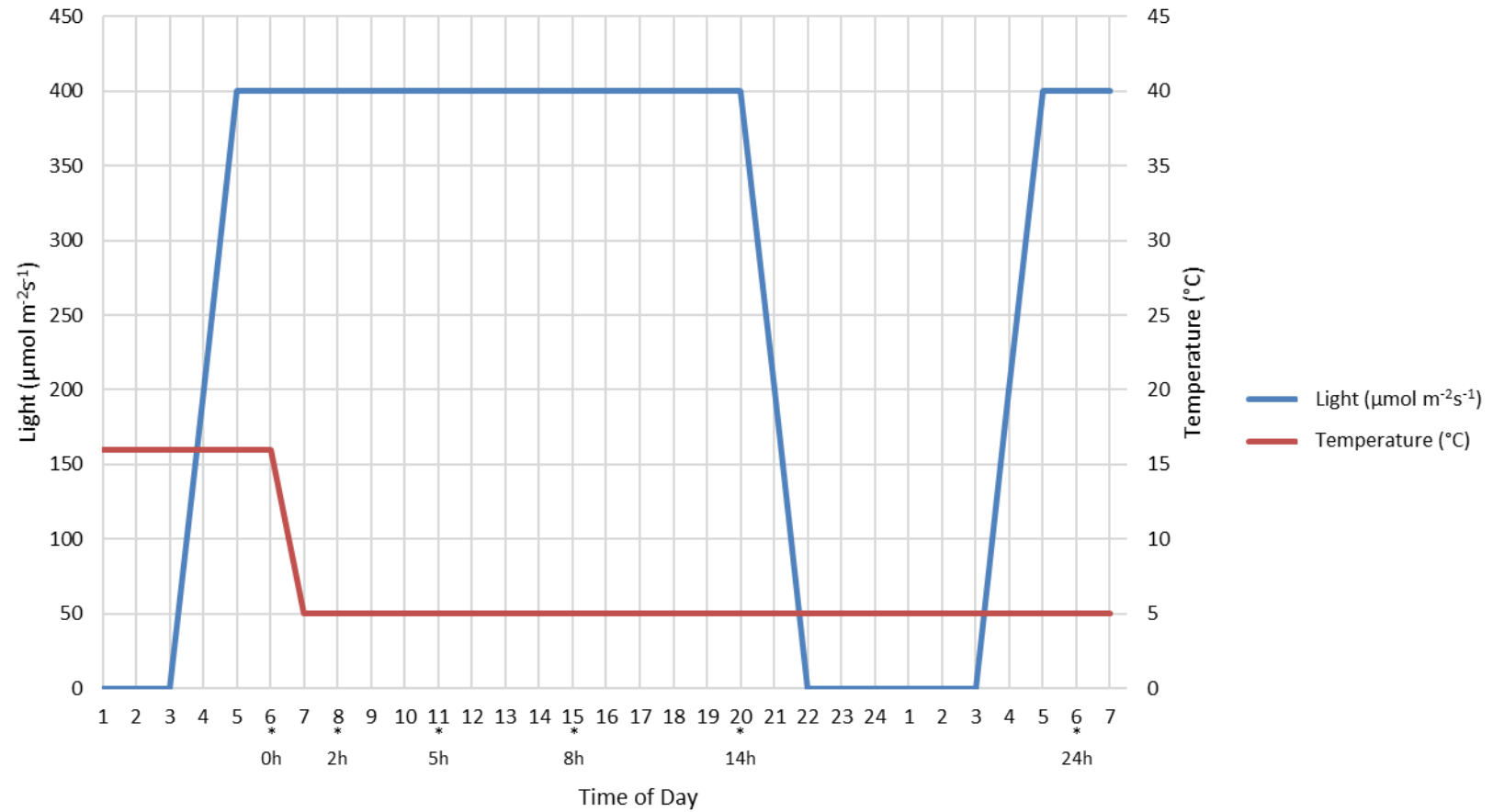

Figure 3.3.1.1. Showing changes in light intensities (blue, primary axis) and temperature (red, secondary axis) across the timecourse in *which Empetrum nigrum* tissue samples were collected for CBF expression analysis. The time of day at which each timepoint at which tissue was collected are marked with a *. Light cycle (blue) was kept consistent from previous growing conditions; temperature was dropped from previous growing conditions (16°C) to 5°C.

2.3.2 *Arabidopsis thaliana* Visual Freezing Assay

Plants were grown as per methods 2.2.4 and members of each line were given a colour coded marker. At an age of 4 weeks, plants were reorganised into repeating patterns to evenly distribute members of the same line, to avoid potential edge effects by having members of the same line clustered together, and were photographed. They were then placed at -7 °C for 24 h followed by 24h at 5 °C, then placed back in growing conditions (methods 2.2.4) and subsequently photographed after 3 days.

-7 °C was selected as the freezing temperature because previous studies found the LT50 for wildtype Col-0 plants was -5 °C for non-acclimated and -10 °C for acclimated plants (when grown in 16-h photoperiod with a day/night temperature of 20 °C/18 °C – similar to our growth conditions) (Hannah et al., 2006). Therefore, since the *CBF* constructs are under a constitutive promoter (simulating activation during acclimation), -7 °C was predicted to be cold enough to isolate non-functional *CBF* constructs from functional ones, with a predicted shift in survival percentages reflecting construct potency.

-7 °C freezing shock was followed by 24 h at 5 °C to gently thaw and return the plants to growth temperatures and reduce sudden heat shock.

2.4 Measuring Indicators of Plant Health

2.4.1 Chlorophyll Content

2.4.1.1 Freezing Tests for Chlorophyll Extractions

Samples for testing were clipped from plants and wrapped in aluminium foil and kept at either; 16 °C, -20 °C or -80 °C for 24 hours then left to defrost at 16 °C for 1 hour before photographing (fresh samples were immediately frozen and stored at -80 °C before being taken onto the extraction step). Samples were then placed in darkened petri dishes at

16 °C and photographed at 24, 51 and 78 hours after removal from freezing. Samples were then frozen in liquid nitrogen and transferred to -80 °C for storage prior to freeze drying.

-20 °C and -80 °C were selected as the preliminary test freezing temperatures to assess the feasibility of this method primarily due to pragmatic reasons; namely the easy availability of freezers at these temperatures (maintaining a steady -15 °C, for example, not being possible with the available laboratory equipment). Had the chlorophyll extraction method been further explored, so would avenues of achieving other freezing temperatures. The main purpose of the initial study was to identify if it was possible to easily perform chlorophyll extractions and clearly identify between living and dead tissue. However, there was also some basis in biology for selecting these temperatures: Previous studies found that ~-15°C is a temperature at which *Calluna vulgaris* is freezing tolerant during months in which it is likely to be acclimated (Sæbø et al., 2001, Caporn et al., 1994), however the sample selected for chlorophyll extraction was likely to experience temperatures below -15 °C in its natural environment (WeatherOnline, 1999-2018, Met-Office, 1959-2018). Therefore, -20°C was deemed an appropriate test temperature. *Empetrum nigrum* has been shown to withstand ~-15 °C prior to acclimation (Yamori et al., 2005) and survive at -80 °C (Yamori et al., 2005) post acclimation, therefore -80 °C was chosen as a second freezing temperature.

2.4.1.2 Chlorophyll Extraction

Chlorophyll content of *Empetrum nigrum* and *Calluna vulgaris* samples was calculated using a modified method from Monni et al. (2001). Samples for chlorophyll extraction were frozen in liquid nitrogen and stored in a -80 °C freezer prior to freeze drying. Freeze dried material was then ground and separated into 10 mg aliquots and 3 ml of 80 % acetone was added and stored overnight at 4 °C. The solution was transferred to a 5 ml

Eppendorf and spun at 3900 G for 3 minutes in a Beckman Coulter Allegra X-22R Centrifuge. Supernatant was transferred into cuvettes and the absorbance measured on a Boeco S-20 spectrophotometer at 647 and 664 nm. If absorbance was too high samples were diluted in 80 % acetone and the equations adjusted accordingly. Chlorophyll *a* and *b* ($\mu\text{mol l}^{-1}$) were calculated using the equations, based on MacKinney's coefficient (Graan and Ort, 1984); Chlorophyll *a* ($\mu\text{mol l}^{-1}$) = $13.19 \times A_{664} - 2.57 \times A_{647}$, and chlorophyll *b* ($\mu\text{mol l}^{-1}$) = $22.10 \times A_{647} - 5.26 \times A_{664}$. The results were then expressed as chlorophyll content per gram of tissue dry weight.

2.5 Primers & Gene Blocks

2.5.1 Primer Design

A full list of primers designed and used in this project can be found in table 2.5.1a-g. Standard pre-existing primers were used for qPCR from *Arabidopsis thaliana* and are therefore not included in the table.

Table 2.5.1a. List of primers designed and used in this project. Showing Primer number code, full primer name (containing species, genus or family designed for), primer sequence and the direction in which the primer primes.

Primer Number	Primer Name	Primer Sequence	Direction
5	Fv-CBF-F	ATGGATGGTGGTTTCTCAGCTTTGT	Forward
6	Fv-CBF-R	CTAAATGGAGTAACTCCATAGTGACACATCA	Reverse
7	Rumex-CBF-F	ATGGAAGAATTTTCAGCTGATATCTACAAGCC	Forward
8	Rumex-CBF-Rev	TCAGAAGCTCCAGAGTGGTAAGTCC	Reverse
9	Ranu-CBF-F	ATGGATTATTCGCAGTACGGTTATCCTTCT	Forward
10	Ranu-CBF-R	TTAATCGTTCCACAAGGACAACCTCCATG	Reverse
11	Trifolieae-SB-CBF-F	ATGTTTACTATGAATCAATTTTCGGAGTCACATGA T	Forward
12	Lamiaceae-KC776910.1-CBF-F	ATGAACAATAAAGACCCTTTATTAGATAGGGATTC ATTAAT	Forward
13	Trifolieae-SC-CBF-F	ATGAATCAATTTTCGGAGTCACATGATCCA	Forward
14	Trifolieae-GA-CBF-F	ATGGATATGTTTACAAATAATAACTCTATTACAC CCC	Forward
15	Asteraceae-GD-CBF-F	ATGAACATGAATGAATCTTATAACTCTTTCCGTCT TC	Forward
16	Asteraceae-GA-CBF-F	ATGAACATGRATAWGWACGCYTCCWACR	Forward
17	Rosaceae-GH-CBF-F	ATGGACKTGCTSAACTTTCCGAC	Forward
18	Rosaceae-GC-CBF-F	ATGGTCATGGACATGATCTTCGCTC	Forward
19	Rosaceae-SA-CBF-F	ATGGATGGTGGATTTTCAGCTTTCCC	Forward
20	Caryophyllales-GB-CBF-F	ATGGCCTCTTTTCGATTACGACAAAGC	Forward
21	Asteraceae-GE-CBF-F	ATGRCTACTTTTATCCAATTTAATGCTGGGAATATT MC	Forward
22	Trifolieae-SA-CBF-F	ATGGATTTCTTCATGTCATCATTTAGTGACTACTCA GA	Forward
23	Asteraceae-GC-CBF-F	ATGRATAYCTTTATCGAAWCMYATAWCCCATTTCC CW	Forward
24	Lamiaceae-HQ443516.1-CBF-F	ATGGATTCATTAGGTTTCATGTTCTGATCCAAATC	Forward
25	Asteraceae-SA-CBF-F	ATGGATATGTACGCCTCCAACAAATCTTATAAC	Forward
26	Trifolieae-GC-CBF-F	ATGTATCCAWCTAMMAACTCTGTCTCTTCYTCT	Forward
27	Caryophyllales-GA-CBF-F	ATGGCTGCTGCAATAGATACATATAGTAGCT	Forward
28	Caryophyllales-SA-CBF-F	ATGGCTACAGCTATTGATATTTACAGTGGT	Forward
29	Ericaceae-CBF-F	ATGGAATATWACTCWAGTCCACATTCGGT	Forward
30	Trifolieae-GB-CBF-F	ATGTTTMCWWCWAASAACYCTTCCTMTTCACA	Forward
31	Rosaceae-SC-CBF-F	ATGAATACGATCTTCAGTCAAATCTCCGA	Forward
32	Lamiaceae-KC776908.1-CBF-F	ATGGACATGTTCTCAAACCTCGTCTGATTC	Forward
33	Rosaceae-GF-CBF-F	ATGAACAGGTTCTTCTCTATTTTTCTGACT	Forward
34	Rosaceae-SB-CBF-F	ATGAATACGATCTTCAGTCAACTCTCCG	Forward

Table 2.5.1b. List of primers designed and used in this project. Showing Primer number code, full primer name (containing species, genus or family designed for), primer sequence and the direction in which the primer primes.

Primer Number	Primer Name	Primer Sequence	Direction
35	Lamiaceae-AY536056.1-CBF-F	ATGGCAGTTTATGATCAGAGTGGAGATAGA	Forward
36	Rosaceae-GE-CBF-F	ATGGATWTGATCTACAGCCAGGTCTCTG	Forward
37	Rosaceae-GA-CBF-F	ATGGATGSTTKCTCTMATTACTACGTGGA	Forward
38	asteraceae-GB-CBF-F	ATGGCTACCCTTATCCMATTCAACACT	Forward
39	Rosaceae-GB-CBF-F	ATGGATGGTTTTTGTCTTACTACGTCTG	Forward
40	Rosaceae-GG-CBF-F	ATGRACACRATCTCCAGACAACTCT	Forward
41	Trifolieae-GD-CBF-F	ATGTWTACWARTAACAAYGGGGAGGGG	Forward
42	Caryophyllales -SB-CBF-F	ATGTGTGGAGGAGCAGTAATCTCC	Forward
43	Poeae-FpB-CBF-F	ATGTGTCCCATCAAGAAAGAGATGAGC	Forward
44	Caryophyllales-SD-CBF-F	ATGAGCTACTCATACCCACCTCCAC	Forward
45	Rosaceae-GD-CBF-F	ATGGACATGTTCTYCKCTCARC	Forward
46	Rosaceae-SD-CBF-F	ATGCTTGAATCGTCGTCGCA	Forward
47	Poeae-SaA-CBF-F	ATGTGCGGGATCAAGCGAGA	Forward
48	Poeae-As-CBF-F	ATGGACATGASC GGCTCSG	Forward
49	asteraceae-SB-CBF-F	ATGGATATCGAATCACACTACCAACATCAAGA	Forward
50	Lamiaceae-KC776909.1-CBF-F	ATGGCGTTCACTGGCTGC	Forward
51	Caryophyllales-SD-CBF-R	TTAAGATGATGATGATAATATAGCATCCCAATCAATCTCA	Reverse
52	Poeae-SaFp-CBF-R	CTAGCTCTGGTAGCTCCAGAGC	Reverse
53	Rosaceae-GF-CBF-R	TYAMTTTGAGAAGCTCCACAGAYTGAC	Reverse
54	Rosaceae-GA-CBF-R	CTAAATGGARWAACTCCAYARTGRCACGT	Reverse
55	Rosaceae-GE-CBF-R	TTAAWYSGAAWAACTCCATARKGSCACGT	Reverse
56	Trifolieae-GD-CBF-R	TCAAAC T GAAAACTCCATAGTGACACCTC	Reverse
57	Lamiaceae-KC776909.1+KC776908.1-CBF-R	TCARAWTGAGTAACTCCAWARTGACACGTC	Reverse
58	Rosaceae-GB-CBF-R	TCAGATAGAGAARCTCCAYARBTTGGVAT	Reverse
59	Lamiaceae-HQ443516.1-CBF-R	TCAAATAGAATAGCTCCAAAGCTCCATCTCA	Reverse
60	Rosaceae-GD-CBF-R	TTAAWTGGAGAACTCCACAAYTGAYATCAG	Reverse
61	Rosaceae-GC-CBF-R	TCAAATAGWAAAACTCCACAGTTTCAAATCATCATCA	Reverse
62	Trifolieae-SB-CBF-R	TCAAATAGAGAAGTTCCAAAGTGAAACTAATTGATGATCA	Reverse

Table 2.5.1c. List of primers designed and used in this project. Showing Primer number code, full primer name (containing species, genus or family designed for), primer sequence and the direction in which the primer primes.

Primer Number	Primer Name	Primer Sequence	Direction
63	Trifolieae-GB-CBF-R	TTAAAATGAGTAACTCCACAATGAAACTTCAGTTT CA	Reverse
64	Caryophyllales-GA-CBF-R	TTAAAGAGAATCCCAGTCAATTTCAAGGGAAG	Reverse
65	Rosaceae-SA-CBF-R	TTATGAGAAGCTCCACAGACTGACGT	Reverse
66	Caryophyllales-SB-CBF-R	TCAGAAGACTCCCCAGGGAAG	Reverse
67	Poeae-As2-CBF-R	TCAGTAGCTCCAGAGCGCG	Reverse
68	Poeae-As1-CBF-R	TCAGCTCCTCCACCGTCTC	Reverse
69	Lamiaceae-KC776910.1-CBF-R	TCAATAGCTCCATAAGGACACGTCAG	Reverse
70	Asteraceae-SaSA-CBF-R	CTAAAAGCTCCATAAAGACGCTTACCA	Reverse
71	Asteraceae-SA-CBF-R	CTAAGAACACCACAACGACATGTCATCA	Reverse
72	Trifolieae-SA-CBF-R	TCAGAAGTTCATAGCGATACCTCTTCA	Reverse
73	Asteraceae-GA-CBF-R	CTARAAGTTCATARVGACATGTYAGCACA	Reverse
74	Caryophyllales-GB-CBF-R	TTACATACCGAGTTCATCAAGATCCAGAAA	Reverse
75	Lamiaceae-AY536056.1-CBF-R	TTAGTTCTCCAGATCCAAGTAACTCAAGTCG	Reverse
76	Asteraceae-SaGB-CBF-R	TYARAACTCCATAATGAMRCRTCAACAMWAA	Reverse
77	Caryophyllales-SA-CBF-R	TCAATCGATCTCCATAGACGGAAAATTATCCA	Reverse
78	Trifolieae-GC-CBF-R	TTAGAAGTTCATAGKGATACCTCWTCATCTTGA	Reverse
79	Asteraceae-GB-CBF-R	TCAAAACTCCATAATGACACRTCAACACTAAAT C	Reverse
80	Asteraceae-SaSB-CBF-R	CTAGAACTCCATAAAGGTAAGTCAACACAGAATT C	Reverse
81	Asteraceae-SvGB-CBF-R	TTAGAACTCCATAATGAAGCGTCAACAAAAAATT C	Reverse
82	Trifolieae-GA-CBF-R	TTAAAAAYTCCAYAGTRATACYTCYTCATCTTGWA ARTCT	Reverse
83	Ericaceae-CBF-R	CTAACTCCACAACGAGACCTCAACATC	Reverse
84	Salicaceae-GA-CBF-F	ATGGATGTTTTCTGTAGTTATTCTGATCAGAACC	Forward
85	Salicaceae-GA-CBF-R	TYAACAGAAAACTCCATAATGACATGTCDGTG	Reverse
86	Salicaceae-SA-CBF-F	ATGGGTACTCTTGATCAATATTCTAAAGCTACTTCT ATG	Forward
87	Salicaceae-SA-CBF-R	TCAAAATCCCAAGTTGAAGTACCCTTCTG	Reverse
88	Salicaceae-GB-CBF-F	ATGGTCHTGGGAGGATCAAATTCST	Forward

Table 2.5.1d. List of primers designed and used in this project. Showing Primer number code, full primer name (containing species, genus or family designed for), primer sequence and the direction in which the primer primes.

Primer Number	Primer Name	Primer Sequence	Direction
89	Salicaceae-GB-CBF-R	TTAACTACTCCACAACGACCAATCAGC	Reverse
90	Salicaceae-SB-CB-F	ATGGAATTTGAGAATCACTCACCATCAATATCTTC	Forward
91	Salicaceae-SB-CB-R	CTAGTCCTCCTCCATAATGTCAAGTCC	Reverse
92	Salicaceae-SC-CBF-F	ATGCCCAATGACAGGCAAGAAG	Forward
93	Salicaceae-SC-CBF-R	CTAATAACTCCATAACGACAAATCAGAACCATTCTC	Reverse
94	Salicaceae-SD-CBF-F	ATGTGTTTATTGTGTCCAACATATGTAACCTTCATGT	Forward
95	Salicaceae-SD-CBF-R	TCACTGAGAATCTAAGTAGTCGTCCTCC	Reverse
96	Salicaceae-SE-CB-F	ATGCTAGCTTCGAGGAATCCGAAG	Forward
97	Salicaceae-SE-CB-R	CTATATAGAAAACTCCATAATGGCATATCAGCGTC	Reverse
98	Corylus-CBF-F	ATGGATATCTTCGCCGATACTCAGA	Forward
99	Corylus-CBF-R	TTAGATTGAGAACTCCATAAAGAACTTCATCAGC	Reverse
100	Betula-CBF-F	ATGGATGTTTTCTCYCAATATTCGTSGGA	Forward
101	Betula-CBF-R	TCAAATTGAGTAACTCCACAATGAAACKTCG	Reverse
102	Brassicaceae-GA-CBF-F	ATGGATCCATTTTACACTTCTTTCTCAGACT	Forward
103	Brassicaceae-SA-CBF-F	ATGAACTCACTTTCTACTATGTTTGGCTCC	Forward
104	Brassicaceae-GB-CBF-F	ATGASCTCATTYCTRCYTTYTCTGAAMTGW	Forward
105	Brassicaceae-GC-CBF-F	ATGGACTCTTTTTCTGCTTTTTCTGAGGTG	Forward
106	Brassicaceae-GD-CBF-F	ATGAACTCATTTTCWGCBTYKCTGARATG	Forward
107	Brassicaceae-SB-CBF-F	ATGAACTCATCATCATTCTCTGCTTTCTCTGA	Forward
108	Brassicaceae-SC-CBF-F	ATGAACTCAGTCTCTACTCTTTCTGAAGTTCTTG	Forward
109	Brassicaceae-SD-CBF-F	ATGGTTGGCTCCGAGAACGAG	Forward
110	Brassicaceae-GE-CBF-F	ATGGATAACWAYGATGRKAYTAWKCTGGCG	Forward
111	Brassicaceae-GF-CBF-F	ATGGAAAACRACRACAWTKYCYTGGC	Forward
112	Brassicaceae-SA-CBF-R	TTAATAGTTGTAACCTCCACAGTGACATATCTTGGT	Reverse
113	Brassicaceae-GA-CBF-R	TTARTAACKGTAACCTCCASAGTGAYRTRTCTTCA	Reverse

Table 2.5.1e. List of primers designed and used in this project. Showing Primer number code, full primer name (containing species, genus or family designed for), primer sequence and the direction in which the primer primes.

Primer Number	Primer Name	Primer Sequence	Direction
114	Brassicaceae-SB-CBF-R	TTAGTAACTCCAAAGTGACAGCTCTTCGT	Reverse
115	Brassicaceae-SC-CBF-R	TTAATAGCTCCATAAGGACACGTCATCATCA	Reverse
116	Brassicaceae-SD-CBF-R	TCAGATTCTCCAAAGGGACACGT	Reverse
117	Brassicaceae-GB-CBF-R	CTARWAACTCCARAGKGACACGTCAG	Reverse
118	Brassicaceae-GC-CBF-R	YTAATAACTCCAGAGGTTYATGTCMRCAWCT	Reverse
119	Brassicaceae-GD-CBF-R	TTAATAGCTCCATAAGGACACGTCATCATCT	Reverse
120	Brassicaceae-GE-CBF-R	TTAATARCTCCATAASGAYACGTCRTCATCWY	Reverse
121	Brassicaceae-GF-CBF-R	TTAGTAACTCCAAAGCGACACGTCAC	Reverse
122	Brassicaceae-GG-CBF-R	TTAATAAYTCCAWAGCGACAVRTCATCWYCR	Reverse
123	Brassicaceae-GH-CBF-R	TTAATAACTCCAWAGGGRCAYGTCRGC	Reverse
124	Brassicaceae-SE-CBF-R	CTATTCTTCGTAACACCTTTCTTCTCCACG	Reverse
125	Rosaceae CBF central region fwd1	GCBGGDMGGARRRDDTT	Forward
126	Rosaceae CBF central region fwd2	GCBGGDMGGARRRDDTTYMR	Forward
127	Rosaceae CBF central region Rev	NGAGTCNGSRAARTTNADVCA	Reverse
128	SAH control 1 (fwd)	TGC AAC ATM TTC TCM ACY AGG	Forward
129	SAH control 2 (rev)	TTR TCA AAC TTG CTC TTG GTR AC	Reverse
130	Ribosomal_S11b_F	ATGGCNGAVCARACNGARARRKC	Forward
131	Ribosomal_S11b_O L06G01490_F	ATGGCTGCCGAGCAACAC	Forward
132	Ribosomal_S11b_O T06G01700_F	ATGCGCGACGCGCAAACC	Forward
133	Ribosomal_S11b_Micromonas_F	ATGGCGGCTGAGCAGACT	Forward
134	Ribosomal_S11b_R	GGCCTGCAYTGNCRRATRV	Reverse
135	Ribosomal_S11b_al gal_R	TTGAADCGRACRGTCTTSGASARV	Reverse
136	ATCBF2_TOPO_F	GCGCGCGCCGCATAACAATGAACTCATTTTCTGCCTTTTCTG	Forward
137	ATCBF2_TOPO_R	GCGCGCGCGCCTTAATAGCTCCATAAGGACACGTC	Reverse
138	LUC-F	GCGCCATTCTATCCGCTAGAGGA	Forward

Table 2.5.1f. List of primers designed and used in this project. Showing Primer number code, full primer name (containing species, genus or family designed for), primer sequence and the direction in which the primer primes.

Primer Number	Primer Name	Primer Sequence	Direction
139	LUC-R	GCTGCGAAATGTTCACTG	Reverse
140	VrCBF4-F	GATTCCTGAATTTGCCTGA	Forward
141	VrCBF4-R	ATGTCATCTCCACCGTAGCC	Reverse
142	GUSPLUS-F	CCGTCCCAAGCAGTTACAAT	Forward
143	GUSPLUS-R	TTCGGAATCTCCACGTTACC	Reverse
144	FiLUC outward p-check Rev	GCCTTATGCAGTTGCTCTCC	Reverse
145	GUS+ outward p-check Rev	AGTGTCGGTCAGCTTGCTTT	Reverse
146	RiLUC outward p-check Fwd	ACCACTGCGGACCAGTTATC	Forward
147	vrCBF4 outward p-check Fwd	TCAGGCAAATTCAGGGAATC	Forward
148	VrCBF4 outward sequencing rev	ATGGCTACGGTGGAGATGAC	Reverse
149	RiLUC outward sequencing rev	AATCGGACCCAGGATTCTTT	Reverse
150	FiLUC outward sequencing fwd	CGTCGCCAGTCAAGTAACAA	Forward
151	bpeCBF1FWD	ATGGATGTTTTCTCTCAATAT	Forward
152	bpeCBF2FWD	ATGGATGTTTTCTCCAATAT	Forward
153	bpeCBF1,2REV	TCAAATTGAGTAACTCCACA	Reverse
154	At CBF1 FWD	ATGAACTCATTTTCTGCTTTTCTGAAATGTTTGG	Forward
155	At CBF1 REV	TTAGTAACTCCAAAGCGACACGTCAC	Reverse
156	VrCBF4 fwd	ATGAATACTTCTCCACCATATTCCGACC	Forward
157	VrCBF4 Rev	CTAAATAGAGTAACTCCATAACGACATGTCAGC	Reverse
26T	26. Trifolieae-GC-CBF-F-TOPO	GCGCGCGCCGCATAACAATGTATCCAWCTAMM AACTCTGTCTCTTCYTCT	Forward
30T	30. Trifolieae-GB-CBF-F-TOPO	GCGCGCGCCGCATAACAATGTTTMCWWCWAA SAACYCTTCTMTTCACA	Forward
14T	14. Trifolieae-GA-CBF-F-TOPO	GCGCGCGCCGCATAACAATGGATATGTTTACAA ATAATAACTCTATTACACCCC	Forward
15T	15. Asteraceae-GD-CBF-F-TOPO	GCGCGCGCCGCATAACAATGAACATGAATGAAT CTTATAACTCTTTCCGTCTTC	Forward
56T	56. Trifolieae-GD-CBF-R-TOPO	GCGCGCGCGCCTCAAACGAAAACCTCCATAGT GACACCTC	Reverse
78T	78. Trifolieae-GC-CBF-R-TOPO	GCGCGCGCGCCTTAGAAGTTCCATAGKGATACCT CWTCATCTTGA	Reverse
82T	82. Trifolieae-GA-CBF-R-TOPO	GCGCGCGCGCCTTAAAAAYTCCAYAGTRATACYT CYTCATCTTGWAAARTCT	Reverse
73T	73. Asteraceae-GA-CBF-R-TOPO	GCGCGCGCGCCTTARAAGTTCCATARVGCATG TYAGCACA	Reverse

Table 2.5.1g. List of primers designed and used in this project. Showing Primer number code, full primer name (containing species, genus or family designed for), primer sequence and the direction in which the primer primes.

Primer Number	Primer Name	Primer Sequence	Direction
29T	29. Ericaceae-CBF-F-TOPO	GCGCGCGCCGCATAACAATGGAATATWACTCW AGTCCACATTCCGGT	Forward
83T	83. Ericaceae-CBF-R-TOPO	GCGCGCGCGCCCTAACTCCACAACGAGACCTCA ACATC	Reverse
22T	22. Trifolieae-SA-CBF-F-TOPO	GCGCGCGCCGCATAACAATGGATTTCTTCATGTC ATCATTTAGTGACTACTCAGA	Forward
62T	62. Trifolieae-SB-CBF-R-TOPO	GCGCGCGCGCCTCAAATAGAGAAGTTCCAAAAGT GAAACTAATTGAGTATCA	Reverse
158	CV EN MATK FWD	KAATTTASGATCAATTCATTCAATATTTC	Forward
159	CV EN MATK REV	AAKGATCCGCTATGATAATGAGAAKATTT	Reverse
160	FWD ERICALES INTERNAL (3)	CACCCVRTDTACMGVGGWGT	Forward
161	FWD ERICACEAE INTERNAL (3)	CACCCVRITYACAGAGGMGT	Forward
162	REV ERICALES INTERNAL (8)	CAMRCYGARTCNGCRAA	Reverse
163	REV ERICACEAE INTERNAL (8)	CACACYGAGTCKGCRAA	Reverse
164	fwd Empetrum specific	GAGACGATGATAAACTGGCTTC	Forward
165	Rev Empetrum specific	CACCCCTTCCATATCCAAAACC	Reverse
166	E.nigrumCBFRTa_F	AAGCCAGCCGGAAGAAAGAA	Forward
167	E.nigrumCBFRTa_R	CCTCGACTTCTTGTTCCGGCT	Reverse
168	E.nigrumCBFRT7_F	AGCGTTATGGTTTCCCCTGG	Forward
169	E.nigrumCBFRT7_R	CCCTCCGCCAATGTCAAAA	Reverse
170	RPB2Ia_F	CAACAGGTTGCGCTTGATTA	Forward
171	RPB2Ia_R	TCTTTGGCATACTGATCCTC	Reverse
172	RPB2Ib_F	GTTGACAACGGAAGGATGT	Forward
173	RPB2Ib_R	TTGTCCCCAGTCCCAGTAG	Reverse
174	35S FWD	ACGTAAGGGATGACGCACAATCCCAC	Forward

2.5.1.1 Standard Primers

The Encyclopaedia of Life (EOL, 2014) was used to find the full NCBI taxonomic classification for each species collected and each classification was recorded in MS Excel. These data were then used to perform NCBI nucleotide searches (Geer et al., 2010) to find the nearest relative(s) of these samples with already sequenced *CBF* genes. Initial searches were performed using the actual species then progressively higher taxa with the search terms *CBF*, DREB1, *DREB* and C-Repeat Binding Factor. A BLASTn (Basic Local Alignment Tool) (Altschul et al., 1990) search was then performed on the nucleotide sequences of any results to identify further relatives with sequenced *CBF* genes within the database. These sequences were then recorded in a Microsoft word 2010 document along with, where present, the protein translation. From these sequences, only those sequences with full coding regions and that were identified as *CBF* genes, rather than other similar sequences, were selected. For each sample the coding sequences of the nearest relatives were imported into Bioedit Sequence Alignment Editor version 7.1.7 (Hall, 1999). Separately the 5' and 3' ends of the sequences were manually aligned and then grouped to create a number of consensus sequences. Groups were based on similarity so that primers designed from the consensus sequence would not contain more than 7 degenerate bases (example: Fig. 2.5.1.1.1). SnapGene version 2.4, using default settings, was used to create primers from these consensus sequences. Since the sequences which were grouped to form a particular forward primer did not necessarily group together to form a reverse primer a list of primer pairings had to be produced. This was performed by recording which forward and reverse primers went together for each sequence. Therefore, only those primer pairs which could have amplified some of the sequences they were designed from were run together with the collected samples. The following is a list of primer pair codes and the two primers which make up that pair (see table 2.5.1a-g) that were used for attempted isolation of *CBF* from members of the named taxon:

Primer pair 1: 11. Trifolieae-SB-CBF-F + 63. Trifolieae-GB-CBF-R

Primer pair 2: 12. Lamiaceae- KC776910.1-CBF-F + 69. Lamiaceae-KC776910.1-CBF-R

Primer pair 3: 13. Trifolieae-SC-CBF-F + 63. Trifolieae-GB-CBF-R

Primer pair 4: 14. Trifolieae-GA-CBF-F + 82. Trifolieae-GA-CBF-R

Primer pair 5: 15. Asteraceae-GD-CBF-F + 73. Asteraceae-GA-CBF-R

Primer pair 6: 16. Asteraceae-GA-CBF-F + 73. Asteraceae-GA-CBF-R

Primer pair 7: 17. Rosaceae-GH-CBF-F + 60. Rosaceae-GD-CBF-R

Primer pair 8: 18. Rosaceae-GC-CBF-F + 58. Rosaceae-GB-CBF-R

Primer pair 9: 19. Rosaceae-SA-CBF-F + 54. Rosaceae-GA-CBF-R

Primer pair 10: 20. Caryophyllales-GB-CBF-F + 74. Caryophyllales-GB-CBF-R

Primer pair 11: 21. Asteraceae-GE-CBF-F + 76. Asteraceae-SaGB-CBF-R

Primer pair 12: 21. Asteraceae-GE-CBF-F + 79. Asteraceae-GB-CBF-R

Primer pair 13: 22. Trifolieae-SA-CBF-F + 62. Trifolieae-SB-CBF-R

Primer pair 14: 23. Asteraceae-GC-CBF-F + 70. Asteraceae-SaSA-CBF-R

Primer pair 15: 23. Asteraceae-GC-CBF-F + 80. Asteraceae-SaSB-CBF-R

Primer pair 16: 24. Lamiaceae- HQ443516.1-CBF-F + 59. Lamiaceae-HQ443516.1-CBF-R

Primer pair 17: 25. Asteraceae-SA-CBF-F + 73. Asteraceae-GA-CBF-R

Primer pair 18: 7. Rumex-CBF-F + 8. Rumex-CBF-Rev

Primer pair 19: 26. Trifolieae-GC-CBF-F + 82. Trifolieae-GA-CBF-R

Primer pair 20: 27. Caryophyllales-GA-CBF-F + 64. Caryophyllales-GA-CBF-R

Primer pair 21: 28. Caryophyllales-SA-CBF-F + 77. Caryophyllales-SA-CBF-R

Primer pair 22: 29. Ericaceae-CBF-F + 83. ericaceae-CBF-R

Primer pair 23: 30. Trifolieae-GB-CBF-F + 56. Trifolieae-GD-CBF-R

Primer pair 24: 30. Trifolieae-GB-CBF-F + 78. Trifolieae-GC-CBF-R

Primer pair 25: 31. Rosaceae-SC-CBF-F + 65. Rosaceae-SA-CBF-R

Primer pair 26: 32. Lamiaceae- KC776908.1-CBF-F + 57.Lamiaceae-
KC776909.1+KC776908.1-CBF-R

Primer pair 27: 33. Rosaceae-GF-CBF-F + 60. Rosaceae-GD-CBF-R

Primer pair 28: 34. Rosaceae-SB-CBF-F + 73. Rosaceae-GF-CBF-R

Primer pair 29: 35. Lamiaceae- AY536056.1-CBF-F + 75. Lamiaceae-AY536056.1-
CBF-R

Primer pair 30: 36. Rosaceae-GE-CBF-F + 61. Rosaceae-GC-CBF-R

Primer pair 31: 9. Ranu-CBF-F + 10.Ranu-CBF-R

Primer pair 32: 37.Rosaceae-GA-CBF-F + 55. Rosaceae-GE-CBF-R

Primer pair 33: 37.Rosaceae-GA-CBF-F + 54. Rosaceae-GA-CBF-R

Primer pair 34: 38. asteraceae-GB-CBF-F + 76. Asteraceae-SaGB-CBF-R

Primer pair 35: 38. asteraceae-GB-CBF-F + 81. Asteraceae-SvGB-CBF-R

Primer pair 36: 39. Rosaceae-GB-CBF-F + 55. Rosaceae-GE-CBF-R

Primer pair 37: 40. Rosaceae-GG-CBF-F + 73. Rosaceae-GF-CBF-R

Primer pair 38: 41.Trifolieae-GD-CBF-F + 72. Trifolieae-SA-CBF-R

Primer pair 39: 41.Trifolieae-GD-CBF-F + 78. Trifolieae-GC-CBF-R

Primer pair 40: 42. Caryophyllales -SB-CBF-F + 66. Caryophyllales-SB-CBF-R

Primer pair 41: 43.Poeae-FpB-CBF-F + 52. Poeae-SaFp-CBF-R

Primer pair 42: 44. Caryophyllales-SD-CBF-F + 51. Caryophyllales-SD-CBF-R

Primer pair 43: 45. Rosaceae-GD-CBF-F + 58. Rosaceae-GB-CBF-R

Primer pair 44: 46. Rosaceae-SD-CBF-F + 60. Rosaceae-GD-CBF-R

Primer pair 45: 47.Poeae-SaA-CBF-F + 52. Poeae-SaFp-CBF-R

Primer pair 46: 48.Poeae-As-CBF-F + 67.Poeae-As2-CBF-R

Primer pair 47: 48.Poeae-As-CBF-F + 68. Poeae-As1-CBF-R

Primer pair 48: 49. asteraceae-SB-CBF-F + 71. Asteraceae-SA-CBF-R

Primer pair 49: 50. Lamiaceae- KC776909.1-CBF-F + 57. Lamiaceae-
C776909.1+KC776908.1-CBF-R

Primer pair 50: 5. Fv-CBF-F + 6. Fv-CBF-R

Primer pair 51: 84. Salicaceae-GA-CBF-F + 85. Salicaceae-GA-CBF-R

Primer pair 52: 86. Salicaceae-SA-CBF-F + 87. Salicaceae-SA-CBF-R

Primer pair 53: 88. Salicaceae-GB-CBF-F + 89. Salicaceae-GB-CBF-R

Primer pair 54: 90. Salicaceae-SB-CB-F + 91. Salicaceae-SB-CB-R

Primer pair 55: 92. Salicaceae-SC-CBF-F + 93. Salicaceae- SC-CBF-R

Primer pair 56: 94. Salicaceae-SD-CBF-F + 95. Salicaceae-SD-CBF-R

Primer pair 57: 96. Salicaceae-SE-CB-F + 97. Salicaceae-SE-CB-R

Primer pair 58: 98. Corylus-CBF-F + 99. Corylus-CBF-R

Primer pair 59: 100. Betula-CBF-F + 101. Betula-CBF-R

Primer pair 60: 102. Brassicaceae-GA-CBF-F + 117. Brassicaceae-GB-CBF-R

Primer pair 61: 103. Brassicaceae-SA-CBF-F + 122. Brassicaceae-GG-CBF-R

Primer pair 62: 104. Brassicaceae-GB-CBF-F + 117. Brassicaceae-GB-CBF-R

Primer pair 63: 104. Brassicaceae-GB-CBF-F + 116. Brassicaceae-SD-CBF-R

Primer pair 64: 104. Brassicaceae-GB-CBF-F + 123. Brassicaceae-GH-CBF-R

Primer pair 65: 105. Brassicaceae-GC-CBF-F + 122. Brassicaceae-GG-CBF-R

Primer pair 66: 106. Brassicaceae-GD-CBF-F + 119. Brassicaceae-GD-CBF-R

Primer pair 67: 106. Brassicaceae-GD-CBF-F + 120. Brassicaceae-GE-CBF-R

Primer pair 68: 106. Brassicaceae-GD-CBF-F + 123. Brassicaceae-GH-CBF-R

Primer pair 69: 106. Brassicaceae-GD-CBF-F + 115. Brassicaceae-SC-CBF-R

Primer pair 70: 106. Brassicaceae-GD-CBF-F + 121. Brassicaceae-GF-CBF-R

Primer pair 71: 107. Brassicaceae-SB-CBF-F + 122. Brassicaceae-GG-CBF-R

Primer pair 72: 108. Brassicaceae-SC-CBF-F + 118. Brassicaceae-GC-CBF-R

Primer pair 73: 109. Brassicaceae-SD-CBF-F + 118. Brassicaceae-GC-CBF-R

Primer pair 74: 110. Brassicaceae-GE-CBF-F + 112. Brassicaceae-SA-CBF-R

Primer pair 75: 110. Brassicaceae-GE-CBF-F + 113. Brassicaceae-GA-CBF-R

Primer pair 76: 111. Brassicaceae-GF-CBF-F + 114. Brassicaceae-SB-CBF-R

Primer pair 77: 111. Brassicaceae-GF-CBF-F + 124. Brassicaceae-SE-CBF-R

Primer pair bpeCBF1: bpeCBF1FW + bpeCBF1,2REV

Primer pair bpeCBF2: bpeCBF2FWD + bpeCBF1,2REV

	10	20	30	40	50	60	70	80	90	100	110	120	130
gi 161897786 gb E	ATGGATATGTTTACAAATAA	TAACTCCTATT	---CACACCCCTTTTCTCCAA	---	CTTGCTCCGAGAGTTCA	TTCC	---	CGAATTCAGAGGGCTCGCAAGGGATG	TCAATTTCCAA	CGAGGAGGTGAG			
gi 525031623 gb K	ATGGATATGTTTACAAATAA	TAACTCCTATT	---CACACCCCTTTTCTCCAA	---	CTTGCTCCGAGAGTTCA	TTCC	---	CGAATTCAGAGGGCTCGCAAGGGATG	TCAATTTCCAA	CGAGGAGGTGAG			
Group A Consensus	ATGGATATGTTTACAAATAA	TAACTCCTATT	---CACACCCCTTTTCTCCAA	---	CTTGCTCCGAGAGTTCA	TTCC	---	CGAATTCAGAGGGCTCGCAAGGGATG	TCAATTTCCAA	CGAGGAGGTGAG			
gi 525031602 gb K	ATGTTTCCATCAAAGAAC	CCCTTCTTCCACATCCCTC	TTCCCTCAAAACCTTCAT	CTTCCCTCACACACAA	TACACTTCCAAATTTAGAGG	TCTCTCGTGGGATGTTT	GTTACCAACGAGG	TC	CGAGGTC	CG			
gi 525031604 gb K	ATGTTTCCATCAAAGAAC	CCCTTCTTCCACATCCCTC	TTCCCTCAAAACCTTCAT	CTTCCCTCACACACAA	TACACTTCCAAATTTAGAGG	TCTCTCGTGGGATGTTT	GTTACCAACGAGG	TC	CGAGGTC	CG			
gi 110559315 gb D	ATGTTTACTACTAACAACT	CTTCTTCCACACTCCATT	CTCAGAACATCTTCTTCT	ACTATAACTCAT	TAC	---	CGGAATC	---	GGAGAT	ACG			
Group B Consensus	ATGTTTMCWNCWAASAA	ACYCTTCTTCTTCCAC	BYCCWBTTCTCARAASC	WCWTCCTTCTTMMY	YAMMYATYACTTC	CRRAWTYAGAGG	TCTCTCGTGGGATGTTT	GTTACCAACGAS	GAGRTM	CG			
gi 161897788 gb E	ATGTATCCA	ACTA	---CAAACCTGTCTCTT	CCT	---	CTTCCCTCCGACATGTC	CGCTGC	---	CGAATTCAGAGGGCTCTCAT	TGGATGTCAATTTGCAAC	CGAGGAGATGCG		
gi 82400105 gb DQ	ATGTATCCA	ACTA	---CAAACCTGTCTCTT	CCT	---	CTTCCCTCCGACATGTC	CGCTGC	---	CGAATTCAGAGGGCTCTCAT	TGGATGTCAATTTGCAAC	CGAGGAGATGCG		
gi 525031611 gb K	ATGTATCCA	ACTA	---CAAACCTGTCTCTT	CCT	---	CTTCCCTCCGACATGTC	CGCTGC	---	CGAATTCAGAGGGCTCTCAT	TGGATGTCAATTTGCAAC	CGAGGAGATGCG		
gi 525031609 gb K	ATGTATCCA	ACTA	---CAAACCTGTCTCTT	CCT	---	CTTCCCTCCGACATGTC	CGCTGC	---	CGAATTCAGAGGGCTCTCAT	TGGATGTCAATTTGCAAC	CGAGGAGATGCG		
gi 525031607 gb K	ATGTATCCA	ACTA	---CAAACCTGTCTCTT	CCT	---	CTTCCCTCCGACATGTC	CGCTGC	---	CGAATTCAGAGGGCTCTCAT	TGGATGTCAATTTGCAAC	CGAGGAGATGCG		
gi 525031615 gb K	ATGTATCCA	ACTA	---CAAACCTGTCTCTT	CCT	---	CTTCCCTCCGACATGTC	CGCTGC	---	CGAATTCAGAGGGCTCTCAT	TGGATGTCAATTTGCAAC	CGAGGAGATGCG		
Group C Consensus	ATGTATCCA	ACTA	---CAAACCTGTCTCTT	CCT	---	CTTCCCTCCGACATGTC	CGCTGC	---	CGAATTCAGAGGGCTCTCAT	TGGATGTCAATTTGCAAC	CGAGGAGATGCG		
gi 357481744 ref	ATGGATTTCTT	CATGTCATCATTTAG	TGATTACTCAGACACTT	CTTCAT	---	CAGAAA	CAGCTTCATC	---	AAACCGTACAAG	TTCTTCAGAA	GTGAT		
Sequence A	ATGGATTTCTT	CATGTCATCATTTAG	TGATTACTCAGACACTT	CTTCAT	---	CAGAAA	CAGCTTCATC	---	AAACCGTACAAG	TTCTTCAGAA	GTGAT		
gi 302952542 gb H	ATGTTTACTATGAAT	CAATTTT	---	CGGAGT	CACATGAT	CC	---	ATGTT	CATCATCTT	CAGAGAGG	TTT		
Sequence B	ATGTTTACTATGAAT	CAATTTT	---	CGGAGT	CACATGAT	CC	---	ATGTT	CATCATCTT	CAGAGAGG	TTT		
gi 357444088 ref	ATGAATCAATTTT	---	---	CGGAGT	CACATGAT	CC	---	ATGTT	CATCATCTT	CAGAGAGG	TTT		
Sequence C	ATGAATCAATTTT	---	---	CGGAGT	CACATGAT	CC	---	ATGTT	CATCATCTT	CAGAGAGG	TTT		
gi 525031629 gb K	ATGTATA	CAAGTAA	CAACG	GGGGAG	GGGGCG								
gi 525031635 gb K	ATGTATA	CAAGTAA	CAACG	GGGGAG	GGGGCG								
gi 525031633 gb K	ATGTATA	CAAGTAA	CAACG	GGGGAG	GGGGCG								
Group D consensus	ATGTATA	CAAGTAA	CAACG	GGGGAG	GGGGCG								

Figure 2.5.1.1. Example of forward primer design for members of the Fabaceae from NCBI sequences in Bioedit. Consensus sequences from which primers were designed highlighted in blue. Primers designed highlighted in green.

2.5.1.2 Primers for Cloning

Primers that successfully amplified a product that we wished to take forward for cloning were re-ordered with a 5' sequence addition to add NOT1 (highlighted yellow) and ASC1 (highlighted pink) restriction sites and a translational initiation consensus sequence (green) to the PCR products. These additional sequences were GCGC^{GCGGCCGC}^{ATAACA} and GCGC^{GGCGCGCC} for the forward and reverse primer respectively.

2.5.1.3 Primers for qPCR

Primers for qPCR from *Empetrum nigrum* RNA were designed using Primer3 to amplify a fragment of between 80 and 1200 base pairs in length. The *CBF* sequence isolated as per sections 2.5.1.1 and 2.7 was used as the template for the test gene. The two best sequences were then ordered, tested and the one that showed best results chosen for future qPCR reactions. The housekeeping gene for *Empetrum nigrum* was selected by searching all sequenced genes of *Empetrum nigrum* in NCBI. Only RPB2I was found to be a suitable housekeeping gene. Primers were then designed to exons in this sequence and tested; the one that worked reliably was then used in further experiments.

Existing qPCR primers for *Arabidopsis thaliana* *CBF*, *KIN2* and *LTI78* were used to investigate gene expression in *A. thaliana* plants.

2.5.2 Synthetic Gene Design

The CBF signature sequences PKKP/RAGR_xKF_xETRHP, identified as crucial for binding of CBF1 to the CRT/DRE element in *A. thaliana* by Canella et al., (2010), and DSAWR were compared between *A. thaliana* CBF 1-4 and sequenced samples. Any amino acid differences in collected sequences within these regions, relative to *A. thaliana*

CBF sequences, were identified and noted. Single amino acid changes were then performed in *A. thaliana* CBF1 to match the amino acid sequence differences within these regions from collected sequences (See Table 2.5.2.1 for list of synthetic genes created and amino acid changes relative to *A. thaliana* CBF1). For sequences with several amino acid changes multiple modified *A. thaliana* CBF1 sequences were produced; sequences with just the singular version of each differing amino acid, then pairs (no more than two amino acid differences within each sequence were observed). A codon usage table was used to select the most appropriate codon for the new amino acid, namely a codon with the most similar usage to the native *A. thaliana* codon. Flanking sequences containing a translational initiation sequence, BAMHI, NOTI, SACI and ASCI cut sites were then added.

These modified *CBF* sequences under a 35S promoter were then ordered from Integrated DNA Technologies Inc. (Glasgow, UK). Gene blocks were supplied dehydrated and were then rehydrated in H₂O to form a 100 µM stock

Table 2.5.2.1. The CBF signature sequences of the synthetic CBF genes created. Changes to *Arabidopsis thaliana* wild type CBF1 highlighted in yellow. No further changes to the CBF1 sequence were made. Short hand names for synthetic genes also shown. CBF WT is a synthetic copy of native *Arabidopsis thaliana* CBF1.

CBF WT	P	K	K	P	A	G	R	K	K	F	R	E	T	R	H	P	...	D	S	A	W	R
PKK	P	K	K	P	A	G	R	K	K	F	K	E	T	R	H	P	...	D	S	A	W	R
DSAWQ	P	K	K	P	A	G	R	K	K	F	R	E	T	R	H	P	...	D	S	A	W	Q
DSLWR	P	K	K	P	A	G	R	K	K	F	R	E	T	R	H	P	...	D	S	L	W	R
DSVWQ	P	K	K	P	A	G	R	K	K	F	R	E	T	R	H	P	...	D	S	V	W	Q
DSVWR	P	K	K	P	A	G	R	K	K	F	R	E	T	R	H	P	...	D	S	V	W	R

2.5.3 Primer Sequences

Primers were ordered from FisherScientific (Loughborough, Leicestershire, UK) and Integrated DNA Technologies Inc. (Glasgow, UK). Primers were supplied dehydrated and were then rehydrated in H₂O to form a 100µM stock.

2.6 DNA and RNA Extraction

2.6.1 DNA Extraction

2.6.1.1 Edwards Extraction

(From Edwards, Johnstone and Thompson, 1991)

Edwards Buffer (All chemicals used were supplied by Sigma-Aldrich Ltd. (Dorset, UK))

for 5 ml buffer:

1 ml of 1 M pH 7.5 Tris-HCl,

1.25 ml of 1 M NaCl,

0.25 ml of 0.5 M pH 8.0 EDTA,

0.25 ml of 10 % SDS,

2.25 ml of H₂O.

DNA was extracted from *Arabidopsis thaliana* using the Edwards extraction method.

Samples were frozen in liquid nitrogen and then ground with a plastic micropestle in a 1.5 ml eppendorf tube. Samples were then vortexed using a Labnet vortex mixer VX100 for 5 seconds after the addition of 400 µl of Edwards extraction buffer. The samples were then spun down in a microcentrifuge (eppendorf AG centrifuge 5415D) at full speed for one minute. 300 µl of the supernatant was then transferred to a fresh 1.5 ml eppendorf and 300 µl of isopropanol added and left at room temperature for 2 minutes. The samples

were then spun at full speed in a microcentrifuge (Eppendorf AG centrifuge 5415D) for 5 minutes and the supernatant removed, the remaining sample was respun for one minute and re-aspirated. The remaining pellet was then spun to dryness using a spin vacuum desiccator (Eppendorf concentrator 5301). The pellet was then resuspended in 30 μ l H₂O and left to dissolve at 4 °C overnight.

2.6.1.2 Powerplant® Pro DNA Isolation

DNA was extracted from all other samples using a modified version of the protocol supplied with PowerPlant® Pro DNA Isolation Kit from Mo Bio Laboratories Inc, USA.

To labelled bead beating tubes 410 μ l of solution PD1 and 40 μ l of Phenolic separation solution were added. Frozen tissue samples were ground in a liquid nitrogen chilled mortar and pestle and added to the bead beating tubes (to a maximum amount of ground tissue of ~1 ml) along with 50 μ l of solution PD2 and 3 μ l of RNase A. Each tube was briefly mixed on a Labnet vortex mixer VX100 then heated at 65 °C for 10 minutes and shaken on a flat-bed vortex (Labnet VX100) at maximum speed for a further 10 minutes. Tubes were then spun at 13000 G for 2 minutes and the resulting supernatant removed to 1.5 ml Eppendorf tubes. To the supernatant 250 μ l of solution PD3 was added, mixed for 5 seconds and then incubated at 4 °C for 5 minutes. After incubation the samples were spun at 13000 G for 2 minutes and a maximum of 600 μ l supernatant, from each sample, was removed to new 1.5 ml Eppendorf tubes. To this supernatant 600 μ l of solution PD4 and 600 μ l of solution PD6 were added and mixed for 5 seconds then ~600 μ l of the mix was loaded onto a spin filter and spun at 10,000 G for 30 seconds, flow through was discarded and ~600 μ l more of the mix added to the spin filter and spun and so forth until all the mix was used. To each spin filter 500 μ l of solution PD5 was then added and they were spun at 10,000 G for 30 seconds and the flow through discarded. Then 500 μ l of solution PD6 was added to each spin filter and they were spun at 10,000 G for 30 seconds

and the flow through discarded. Filters were spun again at 16,000 G for 2 minutes, to remove residual solution PD6 and then placed into new collection tubes. To elute the DNA, 50 µl of 37 °C Nuclease free H₂O was then added to the centre of each spin filter and incubated at room temperature for 2 minutes. After incubation spin filters were spun at 10,000 G for 30 seconds. The spin filter was then placed into another collection tube and the same elution procedure repeated. To check for DNA presence 2 µl of the elution, mixed with 6 µl H₂O and 2 µl loading dye was then run on an 8 % agarose gel. The first DNA elution was then stored at 4 °C and the second at -20 °C.

2.6.2 RNA Extraction

2.6.2.1 RNA Extraction from *Arabidopsis thaliana*

RNA was extracted from using the Promega ReliaPrep™ RNA Tissue Miniprep system as per the protocol using the volumes for less than 5 mg of tissue (even when greater than 5 mg of tissue was used). RNA was then stored at -80 °C prior to cDNA synthesis.

2.6.2.2 RNA Extraction from *Empetrum nigrum*

Numerous methods and kits were tried to extract RNA from *Empetrum nigrum* with various modifications to the protocols. This included QuiAgen RNeasy mini kit, Mo Bio Powerplant® RNA isolation kit and CTAB which all met with limited to no success. Ultimately RNA was extracted from *Empetrum nigrum* samples using a modified GeneAll Ribospin™ Plant protocol. Numerous adaptations were tried until the following modified protocol was selected:

Plant tissue was frozen in liquid nitrogen then ground in a liquid nitrogen chilled mortar. 100 mg was then weighed out into a 1.5 ml Eppendorf. 700 µl of buffer RPL was added and the sample vortexed vigorously prior to incubation at room temperature for 3 minutes.

The sample was then transferred to the EzPure™ filter and centrifuged at 10,000 G for 30 s, the filter was then removed and discarded and the flow through centrifuged at 16,000 G for 2 minutes. The supernatant was then transferred to a new 1.5 ml Eppendorf, an equal volume of 70 % ethanol added, mixed via inversion the applied to a type W spin column (any clots seen in the solution were not transferred). The column was then spun at 10,000 G for 30 s and the flow through discarded. 500 µl of buffer RBW was added to the column, spun again at 10,000 G for 30 s and flow through discarded. 70 µl of DNase I mixture (2 µl DNase I + 70 µl buffer DRB) was then applied to the column and the column incubated at room temperature for 10 minutes. 500 µl of buffer RBW was then added and the column stood for a further 2 minutes before centrifugation at 10,000 G for 30s. Flow through was discarded and 500 µl of buffer RNW was added prior to centrifugation at 10,000 G for 30 s this step was then repeated. A final spin at 10,000 G for 1 minute was then performed before transferal to a new collection tube. 30 µl RNase free water was then added to column and incubated at room temperature for 5 minutes before elution at 16,000 G for 1 minute. The elution step was then repeated for a second or third elution. RNA was then stored at -80 °C prior to cDNA Synthesis.

2.6.3 cDNA Synthesis

cDNA was synthesised from RNA using Applied Biosystems™ High Capacity cDNA Synthesis Kit.

For each CDNA synthesis from *Arabidopsis thaliana* 1 µg of RNA was used. For each CDNA synthesis (for different qPCR experiments) from *Empetrum nigrum* the amount of RNA in 10 µl of the lowest concentration sample was used (0.4297 µg for the timecourse, other concentrations were used for the various qPCR optimisation steps and testing of newly designed qPCR primers).

Per reaction to 10 µl of RNA and water (to desired amount of RNA) 4.2 µl of nuclease free water, 2 µl 10X RT buffer, 2 µl random primers, 0.8 µl 25X 100 mM DNTP mix and 1 µl multiscribe reverse transcriptase were added. For the no reverse transcriptase and no template controls the reverse transcriptase and template RNA, respectively, were replaced with an equal volume of nuclease free water. The samples were then placed in a Hybaid PCRExpress machine set at the following program: 25 °C 10 minutes, 37 °C 120 minutes, 85 °C 5 seconds, 4 °C Hold. cDNA was then stored at -20 °C.

2.7 PCR Amplification and Product Purification

2.7.1 PCR Amplification

2.7.1.1 PCR Mixes

PCR mix 1

Per 50 µl reaction:

39.5 µl, PCR H₂O

5 µl, Bioline 10X buffer

1.5, 50 µM MgCl₂

0.5 µl, 100 µM fwd primer

0.5 µl, 100 µM rev primer

1 µl, 10 µM DNTPs

1 µl, DNA

1 µl, TaQ

PCR mix 2

Per 50 µl reaction:

25 µl KAPA plant PCR buffer + DNTPs (2X) 1.5 mM Mg at 1X

1.5 µl 10µM Forward primer

1.5 μ l 10 μ M Reverse primer
1 μ l DNA
0.4 μ l KAPA3G plant DNA polymerase

MYTAQ PCR

Per 50 μ l reaction:

10 μ l MyTaq Buffer (red)
0.2 μ l 100 μ M Forward primer
0.2 μ l 100 μ M Reverse primer
1 μ l DNA
1 μ l MyTaq DNA polymerase

2.7.1.2 PCR Conditions

Several different annealing step temperatures were used in the following PCR order to find the optimal temperature for the designed primers to anneal. A Thermo PX2 Thermal Cycler and a Hybaid PCR Express were used for PCR.

PCR1-3

1X:

94 °C, 2 minutes

40X:

94 °C, 30 seconds

X °C, 30 s (PCR1: 60-65 °C, PCR2: 48-58 °C, PCR3: 53 °C)

72 °C 45 seconds

1X:

72 °C 10 minutes

4 °C Hold

PCR 4 (KAPA3G)

1X:

95 °C 5 minutes

40X

95 °C 30 seconds

55 °C 15 seconds

72 °C 45 seconds

1X

72 °C 45 seconds

4 °C hold

MY TAQ PCR

X1:

95 °C 1 minute

30X

95 °C 15 seconds

58 °C 15 seconds

72 °C 10 seconds

4 °C hold

2.7.2 Gels

2.7.2.1 TBE Gels

All chemicals used were supplied by Sigma-Aldrich Ltd. (Dorset, UK)

For 5X TBE stock:

54 g l⁻¹ Tris base,

27.5 g l⁻¹ Boric acid,
20 ml l⁻¹ 0.5M pH8 EDTA,
H₂O to desired volume.

In a 500 ml conical flask, 0.5 g agarose (for PCR products) or 0.4 g agarose (for genomic DNA) was dissolved in 50 ml of 0.5X TBE buffer using a Kenwood 850W microwave on full power. Once cooled 2.5 µl Midori Green Direct was mixed into the solution and then poured into an 8cm long gel tank and left to set. Gels were run on a Consort EV243 powerpack at 100V and 35 mAmps for 1 h.

For testing for the presence of DNA after extraction a mixture of 2 µl DNA, 6 µl water and 2 µl 5X orange loading dye was run for each sample on a TBE gel.

For testing for the presence of PCR products a mixture of 8 µl DNA and 2 µl 5X orange loading dye was used and run on a TBE gel.

2.7.2.2 Imaging Gels

Gels were imaged using a Fotodyne Inc. (Wisconsin, USA) UV transilluminator.

2.7.3 PCR Product Purification

2.7.3.1 Gel Extraction

For PCR products with multiple bands, PCR products were purified using gel extraction.

PCR products for gel extraction were run on 0.8 % agarose gels. After sufficient time to allow easy distinction between the bands to be cut out, ~2 hours, gels were dabbed dry with tissue to remove excess TBE. Bands were cut out on a Fotodyne UV transilluminator using scalpel blades. The weight of each gel slice was calculated by deducting the weight

of the 1.5 ml Eppendorf tube before the addition on the gel slice from the weight of the 1.5 ml Eppendorf with the gel slice.

The DNA was extracted from the gel using either a modified version of the protocol from the QIAquick Gel Extraction kit for PCR products to be sequenced (Qiagen, Sussex, UK) (see below) or Monarch® DNA Gel Extraction Kit Protocol (New England Biolabs, UK) as per supplied protocol.

Modified QIAquick Gel Extration Protocol; To one volume of gel 3 1/2 volumes of buffer QG were added and then placed on a Stuart roller mixer SRT6 at room temperature for 15 minutes until the gel had dissolved. One gel volume of ice cold IPA was then added and mixed using a Labnet vortex mixer VX100 for 5 seconds. The sample was then applied to a Promega (Wisconsin, USA) spin column and spun at full speed in a Progen GenFuge 24D centrifuge for 30 seconds. The flow through was then reapplied and re-spun at full speed for 30 seconds. Flow through was discarded and 500 µl of QG buffer added to column and spun at full speed for 1 minute. Flow through was discarded again and 750 µl of buffer PE was then added to the column, incubated at room temperature for 2-5 minutes then spun at 13000RPM for 1 minute. Flow through was again discarded and the column spun at full speed for an additional 2 minutes. The column was then placed in a clean 1.5 ml Eppendorf, and DNA was eluted using 50 µl of warm (~37 °C) H₂O applied to the centre of the column membrane. The column and Eppendorf were left to stand for 2 minutes, then spun at 13000RPM for 1 minute and then the elution procedure was repeated.

DNA concentration was then calculated by running 2 µl of flow through with 6 µl H₂O and 2 µl orange loading dye on an 0.8 % gel and calculating concentration from Hyperladder I relative to band brightness. If necessary elutions were then dried down to

at least 25 ng μl^{-1} using a spin vacuum desiccator (Eppendorf concentrator 5301) in order to be sent for sequencing.

2.7.3.2 Direct From Product Band Extraction

For PCR products showing only a single clearly defined band, PCR products were purified using either the EXO-SAP method or Omega Bio-tek E.Z.N.A cycle pure kit as per protocol

EXO-SAP method: To 16 μl of PCR product 2 μl of EXO-SAP mix (0.2 μl EXO1, 1 μl SAP and 2.8 μl) was added and briefly vortexed on a Labnet vortex mixer VX100. Samples were heated to 37 °C for 15 minutes then 80 °C for a further 15 minutes. Product was then stored at 4 °C prior to being sent to sequencing.

2.7.4 Sequencing and Analysis of Sequence Results

Sanger DNA sequencing was performed by DBS Genomics, Durham University.

2.7.4.1 Quality Control and Cleaning of Sequences

Raw sequences were entered into BLASTX (Altschul et al., 1990) to check for similarity to *CBF* and the results recorded in MS Excel. Chromas LITE version 2.1 was then used to visually inspect sequences for read out accuracy, sequence purity and clarity. Where peak quality or clarity was consistently low sequences were not used for further analysis. Sequences that passed this quality control were again checked for correct base calling, edited manually if necessary, and then exported as a FASTA file. Forward and reverse sequences of the same sample were imported into either BioEdit Sequence Alignment Editor version 7.1.7 (Hall, 1999) and pairwise aligned (with ends allowed to slide) or Jalview Desktop (Waterhouse et al., 2009) and manually aligned. These aligned sequences, where possible, were combined to make one complete sequence. Any

sequences which contained primer sequences had the primer sequences removed from the sequence; this is because we cannot be certain that the primer sequence used was an exact match to the true native sequence. These consensus sequences were then exported as a FASTA file.

2.7.4.2 Protein Translation and Comparison

Nucleotide sequences were then translated into protein sequences using SnapGene version 2.4, Jalview Desktop (Waterhouse et al., 2009) or ExPASy (Gasteiger et al., 2003). The correct reading frame was found via combination of BlastX (Altschul et al., 1990) searches, identification of primer fragments where possible in longer sequences, and using SnapGene-which highlights the ORF with the longest sequence without a stop codon. A search was then performed using BLASTp (Altschul et al., 1990) using these protein sequences to confirm that the correct ORF was chosen via similarity to other CBF protein sequences.

Protein sequences were viewed in Jalview Desktop (Waterhouse et al., 2009) and aligned using Clustal (McWilliam et al., 2013).

2.7.5 Quantitative PCR

A 1:50 dilution of cDNA was used for all qPCR experiments (after initial testing of *Empetrum nigrum* cDNA at 1:10, 1:20, 1:50, 1:100 and 1:200). To 96 wells plates 5 µl of diluted cDNA was added to 10 µl of mastermix consisting of 7.5 µl Promega GoTaq® qPCR 2X SYBR mix with added CXR reference dye, 0.9 µl forward primer, 0.9 µl reverse primer and 0.7 µl nuclease free water per reaction. Three technical replicates were performed for each test sample or control. Reactions with primers for housekeeping genes (*PEX4* for *Arabidopsis thaliana*, and *RPB2I* for *Empetrum nigrum*) were also run on the same plate as the reactions for the test gene with the same cDNA. The plate was then spun

down qPCR performed using the Applied biosystems 7300 qPCR machine. The $\Delta\Delta$ Ct method (Livak and Schmittgen, 2001) was used to calculate gene expression levels and further analysis of the qPCR data was performed using algorithms described in Relative Quantitation (RQ) algorithms, Applied Biosystems Real-Time PCR Systems Software, July 2007 and implemented by (Moffat et al., 2012) namely results were normalised to their respective housekeeping genes via subtraction of Log2 and converted to fold difference relative to WT or time 0.

2.8 Cloning

2.8.1 Media

All chemicals were supplied by Melford laboratories Ltd., Suffolk.

LB agar

20 g l⁻¹ Granulated LB broth Low Salt

15 g l⁻¹ agar

De-ionised water

LB

20 g l⁻¹ Melford Granulated LB broth low salt

De-ionised water

2.8.2 Selection of *Escherichia coli* Containing the pEntr-D-TOPO Vector

Escherichia coli cells containing the pEntr-D-TOPO entry vector plasmid encoding kanamycin resistance and containing Not1 and Asc1 cleavage sites were isolated from a dormant glycerol stock on 10 % concentration kanamycin LB agar plates. Individual

colonies were lifted and re-suspended in 5 ml of LB containing 10 % Kanamycin. Cells were then grown on in an N-Biotek NB-205 shaking incubator at 37 °C shaking at a speed of ~220RPM for approximately 16 hours.

2.8.3 Plasmid Extraction

Plasmids were extracted from the *E.coli* cells using Promega winzard® plus SV minipreps DNA purification system kit with a modified protocol: The LB/*E. coli* mix was transferred into 15 ml Eppendorfs and spun and 10,000 G for 5 minutes in a Beckman Coulter Allegra X-22R Centrifuge. The supernatant was then removed and discarded. The pellet was re-suspended in 250 µl of Cell Resuspension Solution and transferred to a 1.5 ml Eppendorf. To the re-suspended pellet, 250 µl of cell lysis solution was added and mixed by inversion until the solution became transparent. The solution was then incubated at room temperature for 3 minutes followed by the addition of 10 µl of alkaline protease solution, mixed by inversion and incubated at room temperature for a further 3 minutes. After incubation 350 µl of neutralization solution was added, mixed by inversion and spun at 11000 G for 10 minutes in a Progen GenFuge 24D centrifuge. The supernatant was then transferred to a spin column and spun at 11,000 G for 1 minute. Flow through was discarded and 750 µl of wash solution was added prior to spinning at 11,000 G for 1 minute. Again, flow through was discarded and the column spun at 11,000 G for another 2 minutes before being placed in a new tube. The plasmids were then eluted from the spin column by applying 50 µl nuclease free water to the column membrane and spinning the column at 11,000 G for 1 minute. Concentration was then calculated using a Labtech NanoDrop ND-1000 Spectrophotometer and plasmids stored at -20 °C.

2.8.4 Digestion

New England BioLabs' online double digest finder tool (New England BioLabs Inc.) was used to select the buffer and concentrations required for the enzymes. Reactions were performed in a total of 40 μl . Digests were mixed using a Labnet vortex mixer VX100 and Left in 37 °C Water bath overnight to digest. The desired digested fragments were isolated via gel extraction (See section: 2.7.3.1)

Plasmid Digestion

X μl Plasmid*

1 μl Not1HF or BAMHI-HF

1 μl Asc1 or SACI-HF

4 μl 10X CutSmart buffer

To a total of 40 μl with Water

*Where X is the amount of a known concentration of the plasmid to make an overall concentration of 25 $\text{ng } \mu\text{l}^{-1}$ of plasmid.

Insert Digestion

34 μl insert DNA containing NOT1 and Asc1 restriction sites.

1 μl NOT1HF or BAMHI-HF

1 μl Asc1 or SACI-HF

4 μl cut smart buffer

2.8.5 Ligation

A 3:1 molar ratio of vector to insert was used for ligation. Using between 20-200 $\text{ng } \mu\text{l}^{-1}$ of vector per reaction and a maximum concentration of 10 $\text{ng } \mu\text{l}^{-1}$ of insert DNA in the whole reaction. Of the total reaction volume, 0.5 % of T4 DNA ligase and 10 % of 10X

T4 DNA Ligase buffer were also added and the remainder of the volume was made up with water. A control for each reaction was also run where the insert was replaced by water. Ligations were performed in a total volume of 20 μ l and incubated at 16 °C overnight. The ligation was then heat inactivated at 65 °C for 10 minutes.

2.8.6 Transformation Into *Escherichia coli*

Ligation reactions were deactivated via heat shock at 70 °C for 15 minutes using a Thermo PX2 Thermal Cycler or a Hybaid PCR Express. To 40 μ l of α silver competent *E. coli* cells, 4 μ l of the deactivated ligation were added, mixed and placed on ice for 30 minutes. The *E.coli*/ligation mix was then heat shocked to 42 °C using a water-bath in a 42 °C oven for 40 seconds, then placed upon ice again for 2 minutes. To this mixture, 1 ml of 37 °C LB was added and then shaken horizontally for 1 hour. Onto 37 °C pre-warmed 10 % kanamycin LB agar plates, 200 μ l of the transformant was then spread. The remaining mixture was then spun at full speed in a Beckman Coulter Allegra X-22R Centrifuge for 1 minute and the resulting pellet re-suspended in 200 μ l of the supernatant, discarding excess supernatant. This more concentrated transformant solution was then also spread onto 37 °C pre-warmed 10 % kanamycin LB agar plates. All plates were then incubated at 37 °C overnight.

2.8.7 Gibson Assembly and Transformation of Gene Blocks

Synthetic gene blocks were inserted into pENTR-D-TOPO vectors using Gibson assembly as per the protocol (New England Biolabs, Gibson Assembly® Cloning Kit Manual V3.2). Plasmid constructs were then transformed into competent *E. coli* cells either via the cells and protocol provided in the kit or as per 2.8.6 using DH α silver competent cells minus the initial deactivation step. Cells were then spread onto 37 °C pre-warmed 10 % kanamycin LB agar plates and incubated at 37 °C overnight. Single

colonies were then selected, grown in 5 ml LB agar overnight and used to create glycerol stocks (section 2.8.12.1)

For transient expression in *Nicotiana benthamiana* these transformed cells were grown up in 5 ml LB agar at 37 °C overnight then the plasmids extracted as per section 2.8.3 these plasmids were then cut with BAMHI-HF and SACTI-HF alongside PCambia 1305.1 effector plasmid (Nassuth et al., 2014; Fig. 2.8.7.1), run on a gel to isolate the Geneblock insert and the PCambia effector plasmid from their respective digests, gel extracted as per section 2.7.3.1 and ligated and transformed as per sections 2.8.5 and 2.8.6.

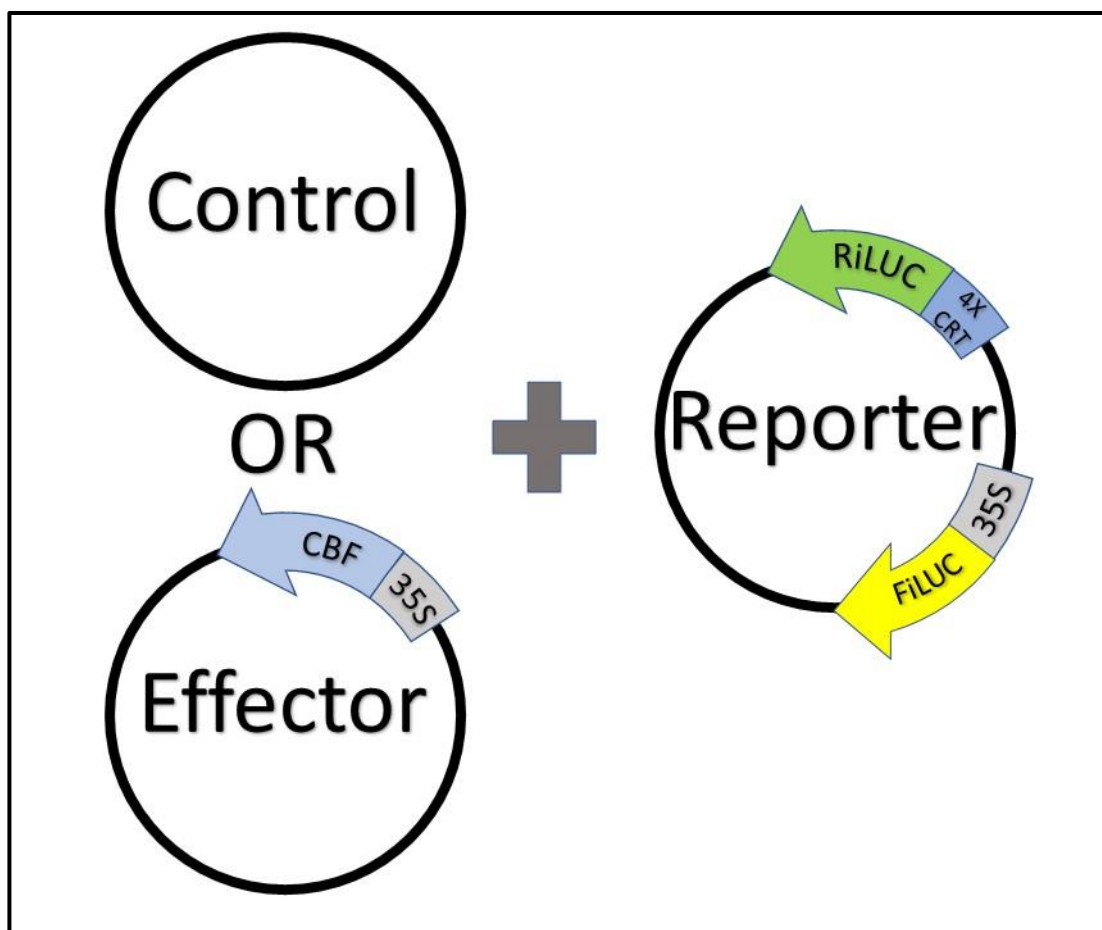

Figure 2.8.7.1 Simplified schematic representation of control, effector and reporter plasmids showing only relevant features. Based on diagram from Nassuth et al.,2014. 35S promoter is a constitutive promoter. The CRT motif is activated by CBF binding. For transient expression studies a combination of either control + reporter or effector + reporter were infiltrated into the leaf.

2.8.8 Transformation into *Agrobacterium tumefaciens*

Two *Agrobacterium tumefaciens* strains were used; GV3101 for transient expression in *Nicotiana benthamiana* or C58C1 for stable transformation into *Arabidopsis thaliana*. 100 μl of cells were used per reaction, to which 1 μg plasmid DNA was added and mixed gently via inversion. Cells and plasmids were then heat shocked at 37 °C for 5 minutes then added to 1 ml of LB which was shaken at 20 °C at 150RPM for 2-4hours. This was then transferred to a 1.5 ml Eppendorf and spun in an eppendorf AG centrifuge 5415D for 30s. The majority of the supernatant was then removed and the pellet resuspended in approximately 200 μl supernatant then plated onto LB plates containing 100 $\mu\text{g ml}^{-1}$ rifampicin and 100 $\mu\text{g ml}^{-1}$ kanamycin. Then incubated at 28 °C for 3 days.

2.8.9 Plasmid Quality Control

At various points cells were checked to ensure they contained the correct plasmid and geneblock insert. This was done via plasmid extraction (section 2.8.3) followed by PCR amplification (Section 2.7.1) using primers 138-157 (table 2.5.1e-f) dependant on what was being checked.

2.8.10 Transient Expression by Infiltration in *Nicotiana benthamiana*

A day prior to infiltration 4 week old *Nicotiana benthamiana* plants were watered and placed in an autoclave bag to increase humidity and open stomata.

Glycerol stocks of *Agrobacteria tumefaciens* containing the binary vectors to be studied; the effector vectors now containing the *CBF* gene blocks, the dual luciferase reporter and pCAMBIA1305.1 control vectors (Nassuth et al., 2014; Fig. 2.8.7.1) were streaked out onto LB-agar plates containing 100 $\mu\text{g ml}^{-1}$ rifampicin and 100 $\mu\text{g ml}^{-1}$ kanamycin and

grown at 29 °C for 3 days. Single colonies were then used to inoculate 5 ml bottles of LB containing the same antibiotics and grown for 24 h at 29 °C shaking at 150RPM in a Jeio Tech SI-300R incubated shaker. The culture was then spun down at 3000 G using a Beckman Coulter Allegra X-22R Centrifuge, supernatant was then discarded and the pellet resuspended in 1 ml 10 mM MgCl₂. 20 µl of this solution was added to 980 µl H₂O and the absorbance measured using a Boeco S-20 spectrophotometer at 600nm wavelength. 10µM MgCl₂ was then added to reach an optical density of 0.3 using the equation $(OD \times 50) / \text{Desired OD} = \text{ml of } 10 \mu\text{M MgCl}_2 \text{ to add to } 1 \text{ ml of construct}$. *Nicotiana benthamiana* leaves were then infiltrated using a 1 ml syringe (without needle) applied with pressure to the underside of the leaf. One half of the leaf contained the effector and reporter plasmid (Fig. 2.8.7.1), the other contained the control (the same plasmid as the effector but without the added *CBF* gene or 35S promoter) and reporter plasmid for comparison (Fig. 2.8.7.1). The edge of the infiltrated area was then marked with black marker. Three leaves, per construct, per experiment, on different individual plants were infiltrated. Plants were then transferred back to previous growth conditions for 48 hours. Three leaf disks, per infiltration, of area 64mm² were then taken and individually floated abaxial side up in aluminium wells filled with 500 µl H₂O. 500 µl of substrate solution (20µM coelenterazine for RiLUC, 2 mM D-Luciferin for FiLUC) was then added and disks were imaged using a Photek photon counting camera and analysed using Photek Image 32.

Photons emitted from the leaf disks were counted over a set period of time (1200 seconds for Fig 4.1.1.3 & 4.1.1.4 and 879 seconds for Fig. 4.1.1.2) and the emission per unit area across the three repeats was calculated, the background reading was then deducted.

FiLUC activation was indicative of the amount of expression due to the constitutive 35S promoter whilst RiLUC was indicative of the degree of activation by *CBF* of the CRT motif (See Fig. 2.8.7.1). Therefore, photon count values for RiLUC (CRT motif) were

divided by corresponding values for FilUC (35S promoter) to normalise for the amount of reporter plasmid. This result for the reporter affected by the control (an effector plasmid lacking the 35S promoter and *CBF* sequence (Fig. 2.8.7.1), was then deducted from the result for the matching reporter affected by the effector plasmid leaf disks (infiltrated on the other half of the leaf to the control) to account for any CRT activation by native *CBFs* or by the introduction of the plasmid.

For figure 4.1.1.1 data were compared across all infiltration events via further normalisation by setting the wildtype overexpressor for each plate as an arbitrary value of 1 and expressing the other constructs as fold changes in CRT expression relative to this.

2.8.11 Stable Transformation of *Arabidopsis thaliana*

Stable transformations were achieved via floral dipping (Clough and Bent, 1998). *Agrobacteria* from previously prepared glycerols were streaked onto LB plates containing 100 µg ml⁻¹ rifampicin and 100 µg ml⁻¹ kanamycin and grown at 29 °C for 3 days, single colonies were transferred to a 5 ml LB containing 100 µg ml⁻¹ rifampicin and 100 µg ml⁻¹ kanamycin and grown at 29 °C for 48 h in a Jeio Tech SI-300R incubated shaker at 150RPM. These cultures were then used to inoculate a 200 ml LB flask containing the same concentration of antibiotics. This was grown at 29 °C for 24 h in a shaking incubator Jeio Tech SI-300R incubated shaker at 150RPM. The cultures were then centrifuged at 3500 G for 15 minutes using a Beckman Coulter Allegra X-22R Centrifuge and the supernatant discarded. The pellet was then gently resuspended in 200 ml of 5 % sucrose solution plus 0.5 µl ml⁻¹ of Lehle Vac-In-Stuff silwet L-77. Plants prepared for dipping (section 2.2.4) were then physically dipped head first in a beaker of this solution and swilled round. Plants were then lain on their side in a tissue lined plastic tray and covered with clingfilm to maintain high humidity for 24 h. Clingfilm and tissue was then removed

and plants righted and watered and grown in long day conditions (section 2.2.4) until ready for seed harvesting.

2.8.12 Stocks and Storage

2.8.12.1 Glycerol Stocks

Glycerol stocks were made from 0.525 ml culture added to 0.25 ml 100 % glycerol. The stock was then flash frozen in liquid nitrogen and stored at -80 °C.

2.9 Phenotypic Scoring

All *Empetrum nigrum* and *Calluna vulgaris* plants grown from cuttings were photographed using an Olympus OM-D EM-5 on 13/08/18 and 20/08/18 respectively. Two photographs per plant were taken, one top-down view and one side view with the pots laid on their side to accommodate the sprawling nature of several specimens. All photographs were then added to a excel spreadsheet documenting various details of each specimen including, code, location harvested from (including GPS location and altitude) (see supplementary disk Excel documents “Morphology *Calluna vulgaris*” and “Morphology *Empetrum nigrum*”). All specimens were given a random number code then just the code and associated photographs were transferred to a separate sheet and sorted by random number to maintain anonymity of sample details and avoid unconscious bias. All samples were then given a rank code by eye based on the morphology of the sample; ranging from 1 for very leggy samples with very little/no branching, long stems, widely spaced leaves and thin stems, to 10 for highly compact samples with frequent branching, short branches, closely bunched leaves and thick stems. This was repeated three times to avoid potential influence of previous image(s) morphology on the score of the following image. The mean of these scores was then used.

Results were then visualised using Microsoft Excel 2016 to produce scatter graphs of the data; each series then being colour-coded based on locale. The data were then imported into R (R Core Team, 2014) and Spearman's Rank Correlation tests performed for each comparison.

Chapter 3: Isolating and Analysing C-Repeat Binding Factor (CBF) Sequences from Arctic, Alpine and Moorland Plant Species

Aims and Objectives

The aims of this chapter were to isolate full *CBF* coding sequences from a wide variety of Arctic, alpine and moorland species and to compare these *CBF* sequences, in order to identify any polymorphisms which could affect *CBF* activity, particularly any polymorphisms common between distantly related species. The majority of species collected had no previous *CBF* sequence data available, therefore primers were designed from pre-existing sequences of the closest known relatives of the species collected (methods section: 2.5.1.1). In order to isolate the full coding sequences these primers were designed to the 3' and 5' end of the sequence, which contain a high degree of sequence variation. Therefore, it was unknown if these primers would be sufficiently specific to isolate corresponding *CBF* sequences from related species. The primary objective of this chapter was therefore to identify if primers designed in this manner could amplify *CBF* sequences from other species and, if so, for each collected species, which of these primers could be used to isolate *CBF* sequences from that particular species.

Hypotheses

- It is possible to isolate full *CBF* sequences from a wide range of species using primers designed to the 3' and 5' ends of pre-existing *CBF* sequences of closely related species.

- *CBF* sequences from Arctic, alpine and moorland species will contain polymorphisms in regions previously identified as influencing CBF binding and activity.
- Common polymorphisms will be observed across distantly related Arctic, alpine and moorland species.

3.1 Results

3.1.1 *CBF* Nucleotide Sequences

CBF sequences could not be successfully isolated from a large number of species. Of those that were successfully isolated Clustal (Larkin et al., 2007) alignments of *CBF* nucleotide sequences were split into three groups for ease of analysis. Brassicaceae (Fig. 3.1.1.1.1 a-b), Ericaceae (Fig. 3.1.1.2.1 a-b) and all other remaining genera (Fig. 3.1.1.3.1 a-c). All were compared to *Arabidopsis thaliana CBF1-4* sequences. When sorted by Clustal *Arabidopsis thaliana CBF1-4* sequences grouped together except in the case of the Brassicaceae alignment (of which *Arabidopsis* is itself a member) (Fig. 3.1.1.1.1 a-b).

3.1.1.1 Brassicaceae

Sample 68 *Capsella bursa-pastoris* consisted of four distinct sequences. The sequences amplified by primer pair 61 and 71 (Table 2.5.1a-g) were very similar to one another except for 1 nucleotide difference near the start of the primer pair 61 sequence (T to G) (Fig. 3.1.1.1.1 a). The sequences were otherwise identical except for some degenerate bases and that the readable sequence amplified by primer pair 61 was shorter (Fig. 3.1.1.1.1 a-b). Another set of sequences which were identical to one another (except that a shorter section of sequence was readable for the sequence amplified by primer pair 64) were amplified primer pairs 64 and 68 (Table 2.5.1a-g) (Fig. 3.1.1.1.1 a-b). A unique

sequence was amplified by primer pair 75 (Table 2.5.1a-g) (Fig. 3.1.1.1.1 a-b). Another distinct sequence was amplified by primer pair 76 (Table 2.5.1a-g) (Fig. 3.1.1.1.1 a-b).

Two distinct sequences were amplified from sample 66 *Cardaminopsis arenosa*. One sequence, amplified by primer pair 77 (Table 2.5.1a-g) was identical to that amplified from sample 68 *Capsella bursa-pastoris* using primer pair 76 (Table 2.5.1a-g) (Fig. 3.1.1.1.1 a-b). Three sequences identical to one another (except for one degenerate base) but distinct from other sequences were amplified using primer pair 66, 69 and 67 (Table 2.5.1a-g) (Fig. 3.1.1.1.1 a-b).

One sequence was amplified from sample 69 *Arabis alpina* using primer pair 77 (Table 2.5.1a-g). This sequence was very similar to the sequence amplified from sample 68 *Capsella bursa-pastoris* using primer pair 76 and sample 66 *Cardaminopsis arenosa* primer pair 77 (Fig. 3.1.1.1.1 a-b).

One sequence was amplified from sample 64 *Barbarea vulgaris* using primer pair 60 (Table 2.5.1a-g). This sequence displayed a large number of differences when compared to all other *Brassicaceae* *CBF* sequences except for *Arabidopsis thaliana* *CBF4* to which it showed greater similarity and grouped with during Clustal sorting (Fig. 3.1.1.1.1 a-b).

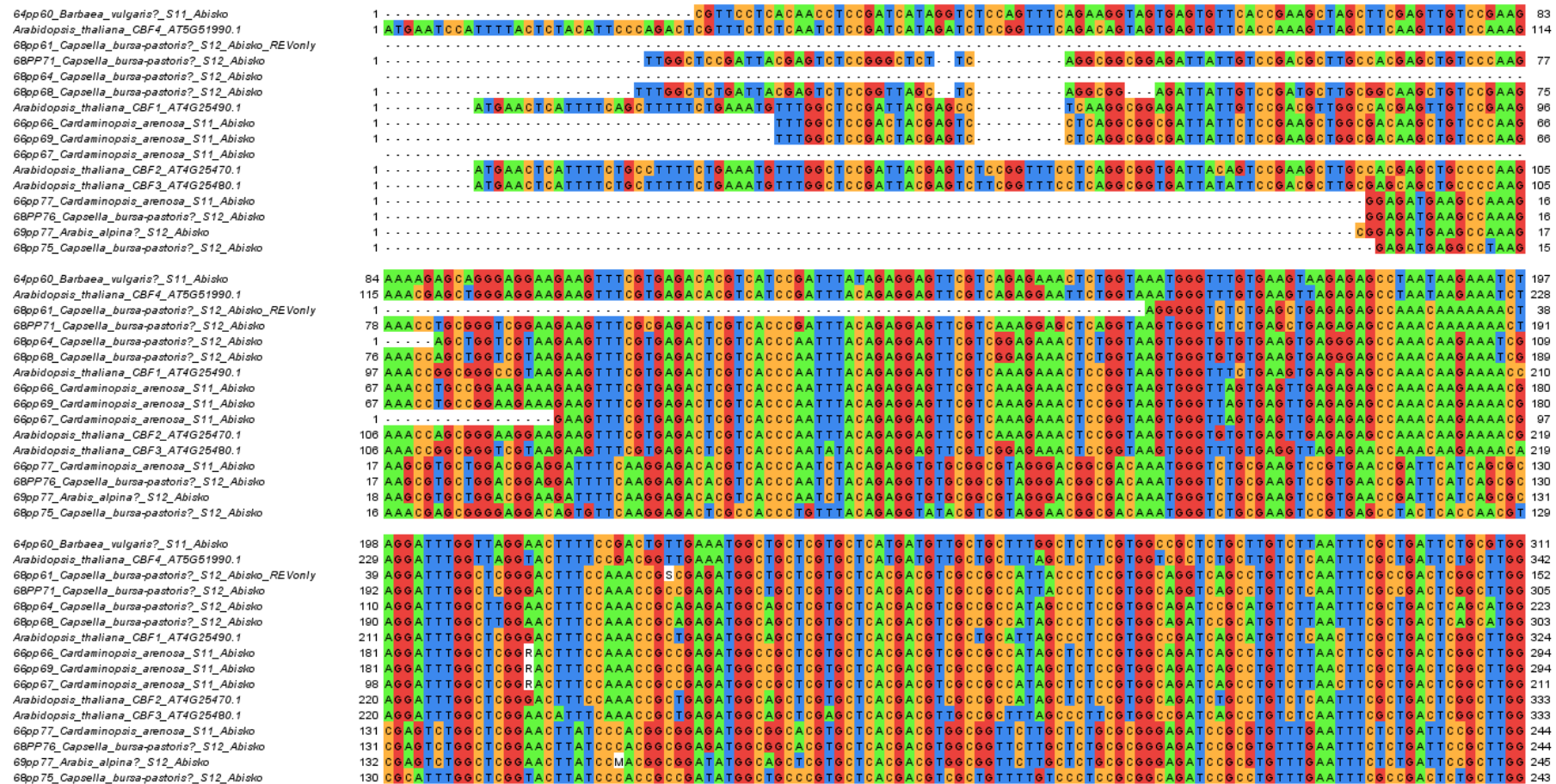

Figure 4.1.1.1.a Clustal alignment of *CBF* nucleotide sequences isolated from members of the *Brassicaceae* compared to *Arabidopsis thaliana CBF1-4* genbank sequences. Sequences are ordered by Clustal sorting. Names are in the form “Species code pp primer pair code_Genus_Species_Site code_Location”. Genbank gene names are in the form “Genus_Species_Gene_Genbank code”.

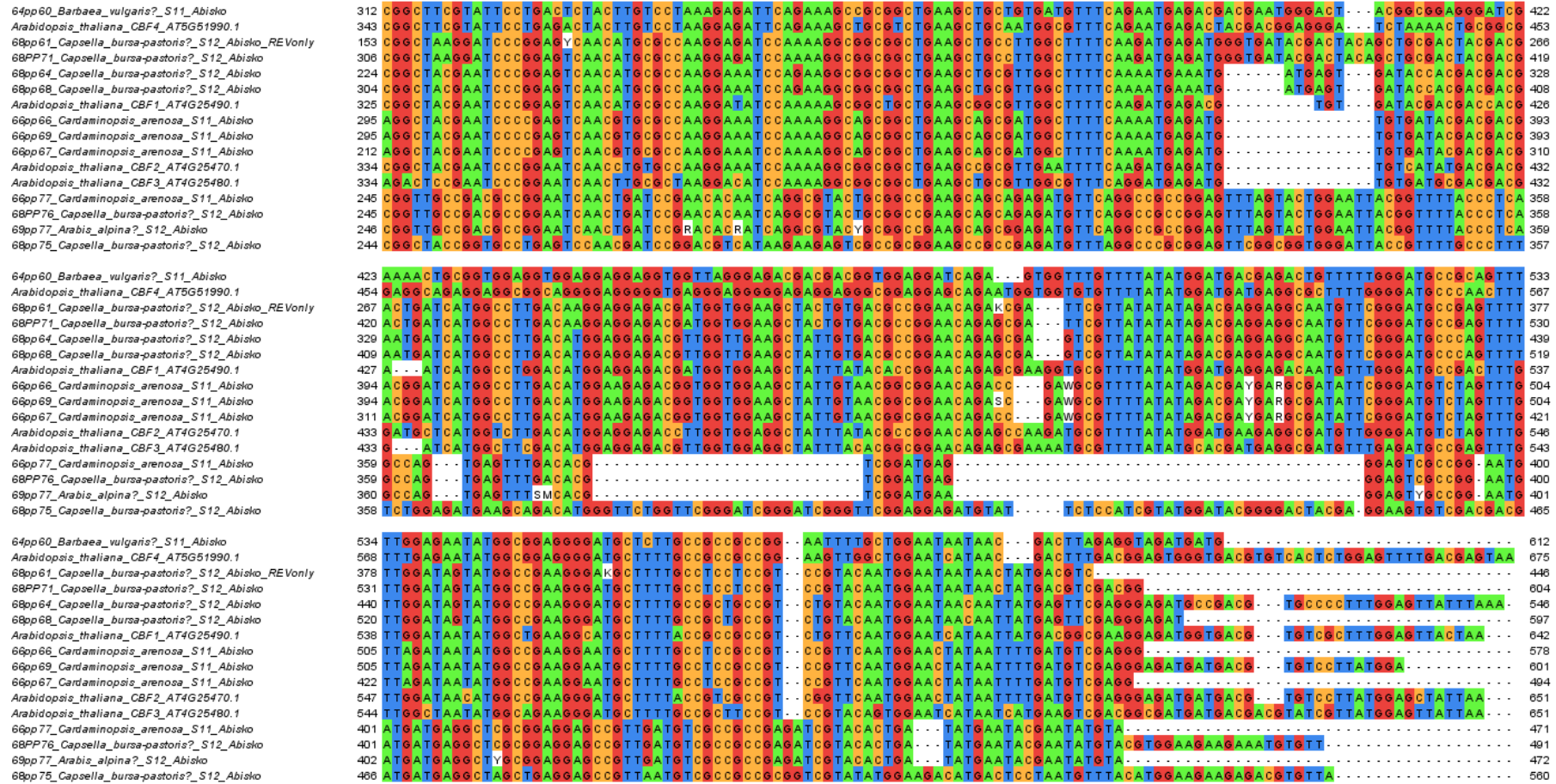

Figure 3.1.1.1.1 b. Clustal alignment of CBF nucleotide sequences isolated from members of the Brassicaceae compared to Arabidopsis thaliana CBF1-4 genbank sequences. Sequences are ordered by Clustal sorting. Names are in the form “Species code pp primer pair code_Genus_Species_Site code_Location”. Genbank gene names are in the form “Genus_Species_Gene_Genbank code”.

3.1.1.2 *Ericaceae*

All *Ericaceae* sequences were more similar to one another than to the *Arabidopsis thaliana* sequences (Fig. 3.1.1.2.1 a-b). Only one primer pair was used for all *Ericaceae* *CBF* amplification (primer pair 22 – For primer pair list see section 2.5.1.1 and Table 2.5.1a-g)

All *Andromeda polifolia* sequences from sample 43 (bands A-D) (Abisko, Sweden) and sample 18 (Abisko, Sweden) were very similar to one another (Fig. 3.1.1.2.1 a-b). The sequence isolated from band A of sample 43 was more similar to the sequence from sample 18pp22 than to bands B, C and D isolated from sample 43 (Fig. 3.1.1.2.1 a-b). However, similarity was still high across all sequences, more-so than seen between the different *CBF* genes (1-4) within *Arabidopsis thaliana* (Fig. 3.1.1.2.1 a-b).

Vaccinium vitis-idaea samples 10 (Abisko, Sweden), 40 (Abisko, Sweden) and 118 (Weardale, UK) had identical *CBF* sequences except for two degenerate bases seen in sample 10 (Fig. 3.1.1.2.1 a-b).

The sequence from *Vaccinium myrtillus* sample 114 was more similar to *Vaccinium vitis-idaea* sequences than sequences from other species but was definitely a distinct sequence to the *Vaccinium vitis-idaea* sequence (Fig. 3.1.1.2.1 a-b).

The three *Empetrum nigrum* sequences from sample 5 (sequences A-C isolated by TOPO cloning) were almost identical to one another except for a small number of substitutions between sequences (Fig. 3.1.1.2.1 a-b).

Sample 3 *Arctostaphylos alpina* and sample 2 *Diapensia lapponica* had identical sequences to sequence A from sample 5 (Fig. 3.1.1.2.1 a-b).

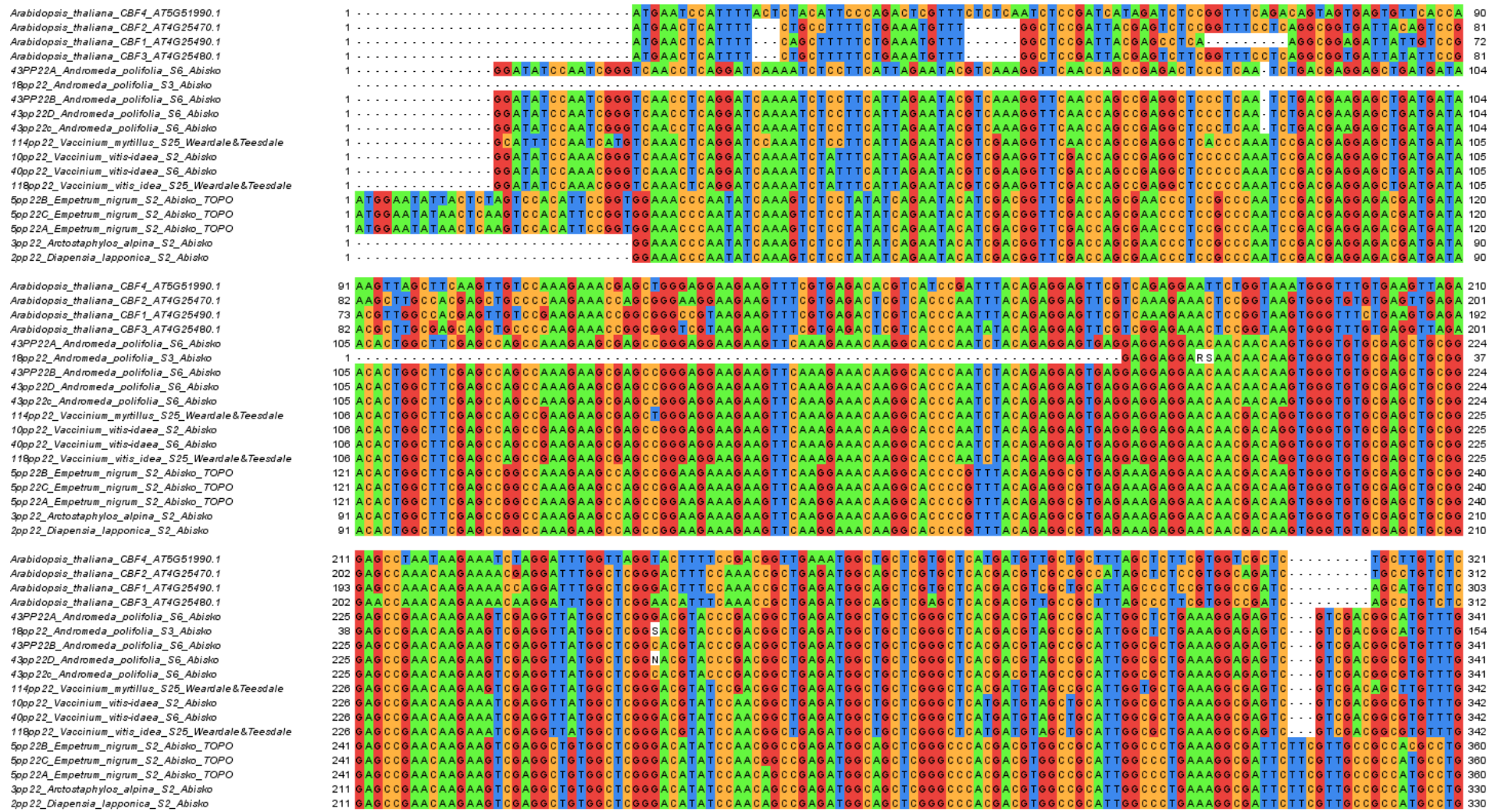

Figure 3.1.1.2.1.a. Clustal alignment of *CBF* nucleotide sequences isolated from members of the *Ericaceae* compared to *Arabidopsis thaliana CBF1-4* genbank sequences. Sequences are ordered by Clustal sorting. Names are in the form “Species code pp primer pair code_Genus_Species_Site code_Location”. Genbank gene names are in the form “Genus_Species_Gene_Genbank code”.

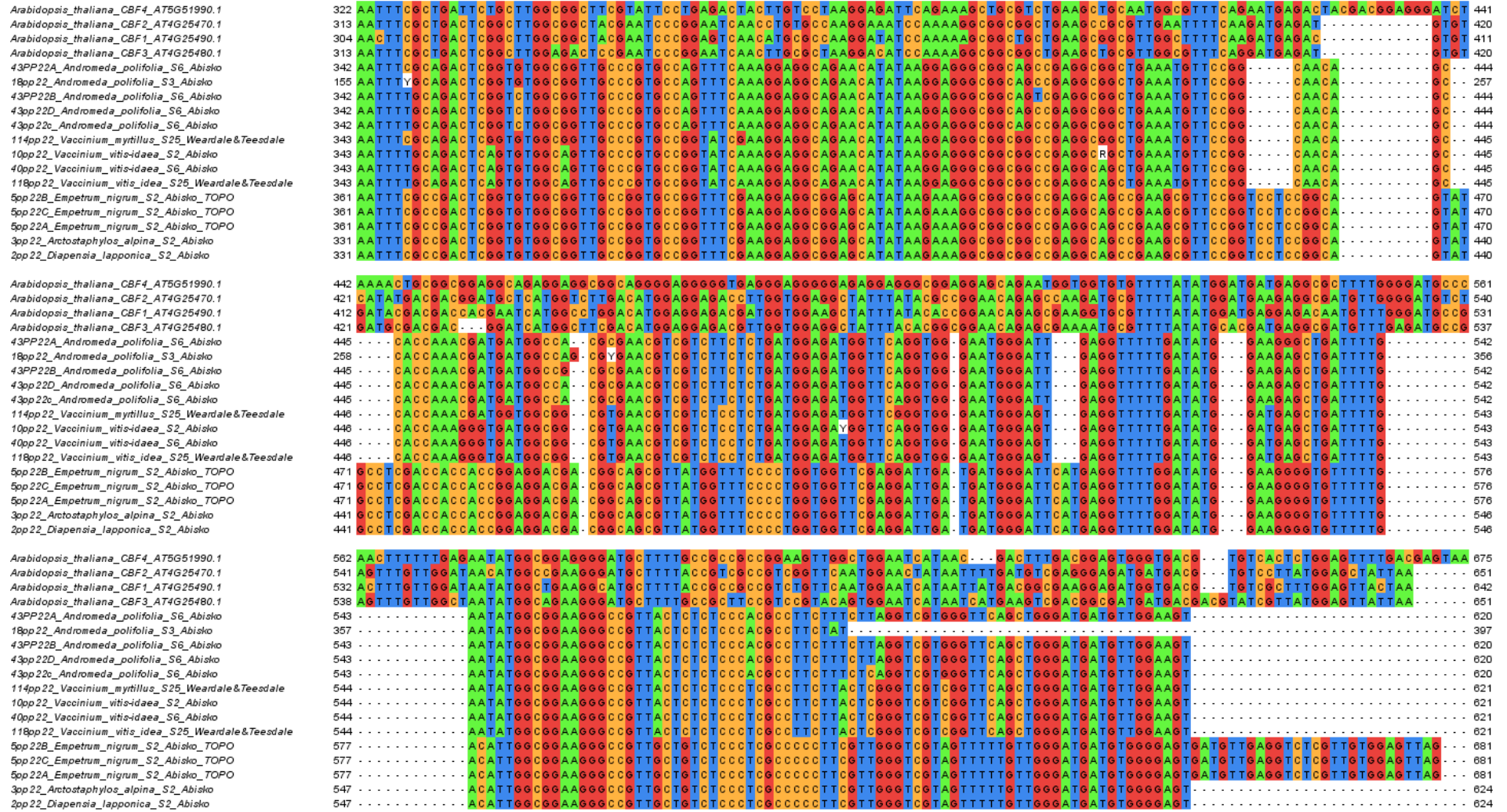

Figure 3.1.1.2.1 b. Clustal alignment of CBF nucleotide sequences isolated from members of the *Ericaceae* compared to *Arabidopsis thaliana* CBF1-4 genbank sequences. Sequences are ordered by Clustal sorting. Names are in the form “Species code pp primer pair code_Genus_Species_Site code_Location”. Genbank gene names are in the form “Genus_Species_Gene_Genbank code”.

3.1.1.3 All Other Species

Two distinct sequences were isolated from *Trifolium repens*. One sequence isolated from samples 58 (Abisko, Sweden), 77 (Weardale, UK) and 94 (Weardale, UK) using primer pair 13 (Table 2.5.1a-g) contained an 18 base insertion (Fig. 3.1.1.3.1 b) not seen in other *CBF* sequences (which would result in an additional 6 amino acids). The sequences were mostly identical to one another except for some degenerate bases. The second sequence was isolated from the same samples using different primer pairs; sample 58 using primers 19 and 23, sample 77 using primer pairs 19, 23 and 24 and sample 94 using primer pairs 19 and 23 (Table 2.5.1a-g), these sequences were very similar to one another with some substitutions and degenerate bases (Fig. 3.1.1.3.1 a-c).

All sequences isolated from *Betula nana* (sample 4 and sample “nula” (both from Abisko, Sweden)) using primer pairs CBF1, CBF2 and 59 (Table 2.5.1a-g) were very similar to one another (Fig. 3.1.1.3.1 a-c).

Fragaria vesca samples 74 (Abisko, Sweden) and 78 (Weardale, UK) had identical *CBF* sequences (Fig. 3.1.1.3.1 a-c) amplified using primer pair 50 (Table 2.5.1a-g).

Two distinct sequences were amplified from *Salix herbacea* sample 51 using primer pairs 51 and 53 (Table 2.5.1a-g). Not only were these sequences very different from one another they were also very different from any of the other sequenced *CBFs* (Fig. 3.1.1.3.1 a-c). However, megablast (NCBI, 2018) indicated high similarity to *CBF* sequences from a variety of *Populus* species.

CBF sequences isolated from sample 63, *Matricaria recutita* using primer pairs 5, 6 and 17 (Table 2.5.1a-g) were very similar to one another (Fig. 3.1.1.3.1 a-c) except for some degenerate bases and variation at the start of the sequence (Fig. 3.1.1.3.1 a).

Sample 90, *Leucanthemum vulgare*, had a *CBF* sequence (amplified by primer pair 12 – See section 2.5.1.1) distinct from but very similar to that of sample 63 *Matricaria recutita* (Fig. 3.1.1.3.1 a-c).

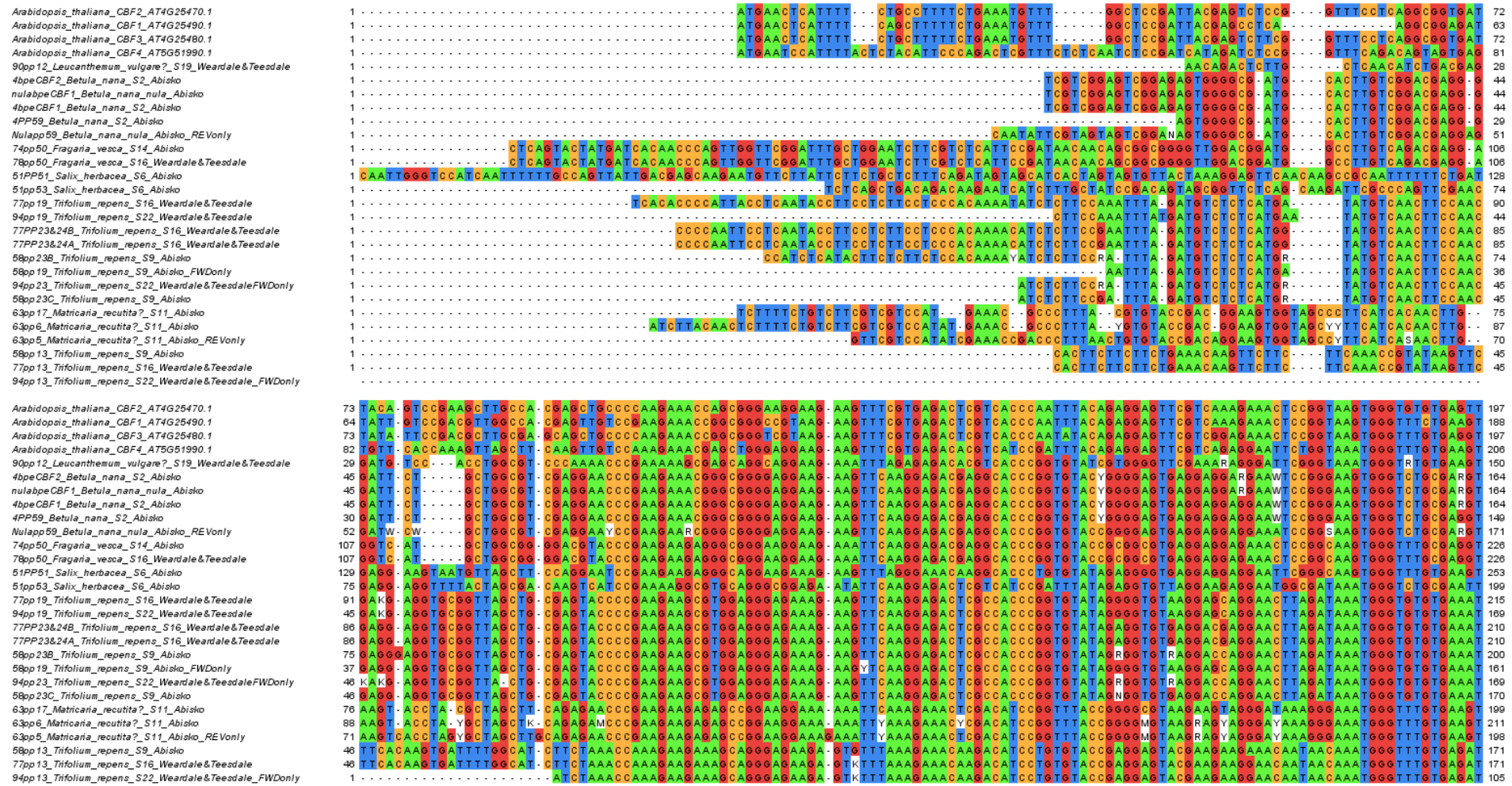

Figure 3.1.1.3.1 a. Clustal alignment of *CBF* nucleotide sequences isolated from all other species that were not members of the *Ericaceae* or *Brassicaceae* compared to *Arabidopsis thaliana* *CBF1-4* genbank sequences. Sequences are ordered by Clustal sorting. Names are in the form “Species code pp primer pair code_Genus_Species_Site code_Location”. Genbank gene names are in the form “Genus_Species_Gene_Genbank code”.

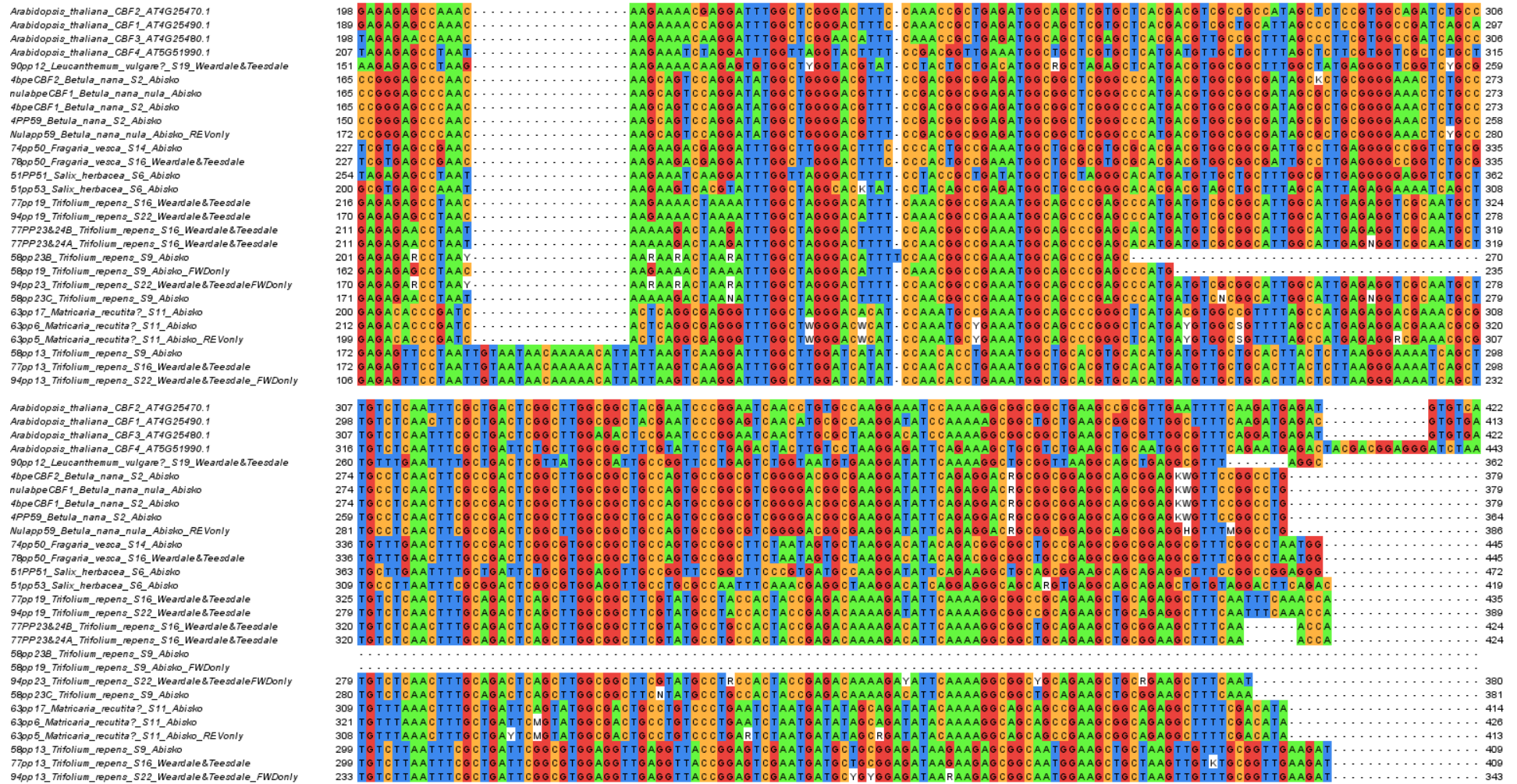

Figure 3.1.1.3.1 b. Clustal alignment of *CBF* nucleotide sequences isolated from all other species that were not members of the *Ericaceae* or *Brassicaceae* compared to *Arabidopsis thaliana* *CBF1-4* genbank sequences. Sequences are ordered by Clustal sorting. Names are in the form “Species code pp primer pair code_Genus_Species_Site code_Location”. Genbank gene names are in the form “Genus_Species_Gene_Genbank code”.

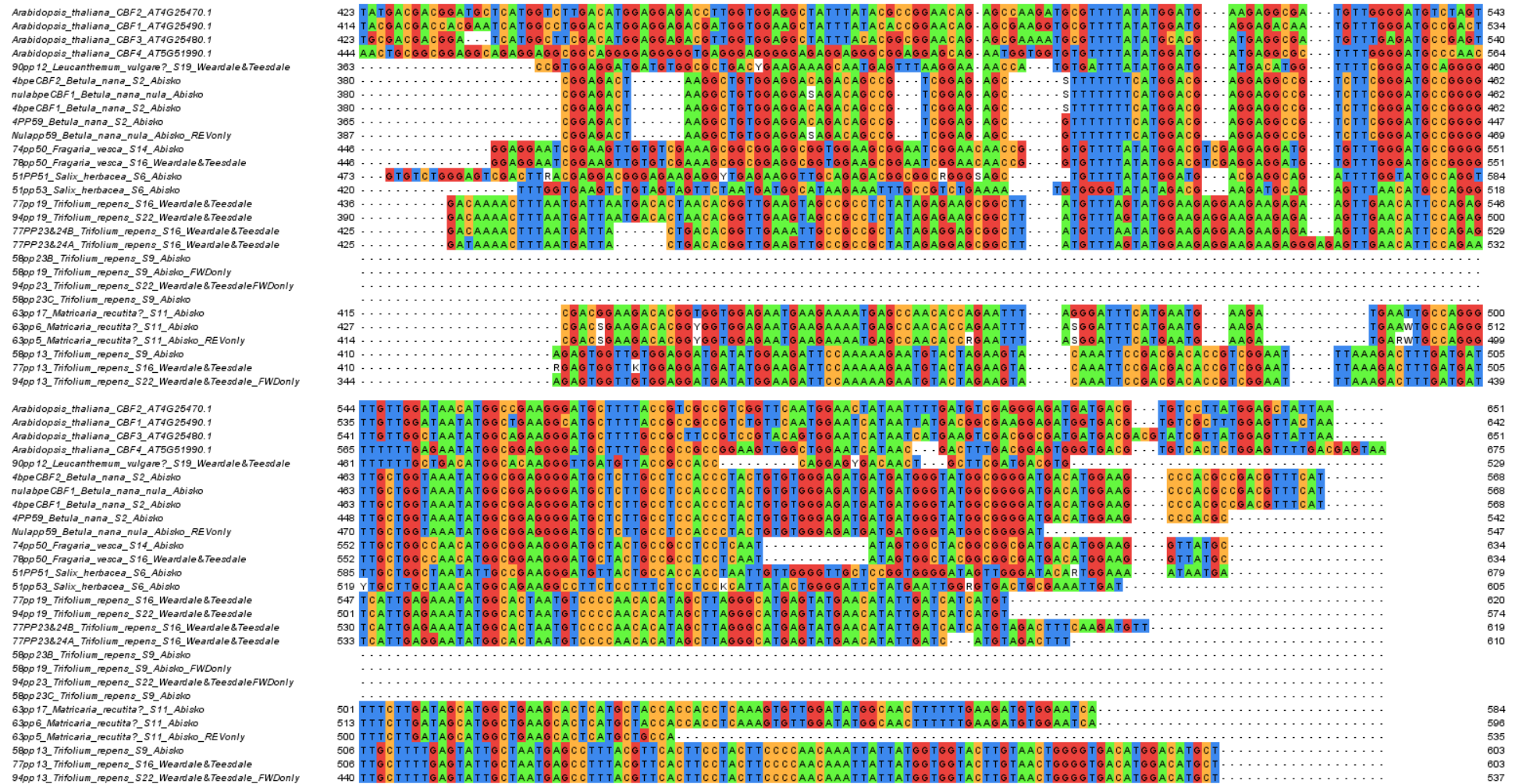

Figure 3.1.1.3.1 c. Clustal alignment of *CBF* nucleotide sequences isolated from all other species that were not members of the *Ericaceae* or *Brassicaceae* compared to *Arabidopsis thaliana* CBF1-4 genbank sequences. Sequences are ordered by Clustal sorting. Names are in the form "Species code pp primer pair code_Genus_Species_Site code_Location". Genbank gene names are in the form "Genus_Species_Gene_Genbank code".

3.1.2 Translated CBF sequences

*Note: The terms substitution, insertion or deletion are used simply relative to *Arabidopsis thaliana* CBF1; they do not have any evolutionary significance.*

There was greater amino acid sequence conservation across all species than nucleotide conservation (Fig. 3.1.2.1a-b vs Fig. 3.1.1.1.1 a-b, Fig. 3.1.1.2.1 a-b, Fig. 3.1.1.3.1 a-c).

All sequences, where sequence reads covered those regions, had CBF signature sequences with the possible exception of 63pp5 *Matricaria recutita* which had numerous differences in this region relative to other sequences (Fig 3.1.2.2).

The majority of variation between species was in the COOH-terminus (Fig. 3.1.2.1 b). Members of the same family tend to be similar to one another.

Arabidopsis thaliana CBF1-3, *Cardaminopsis arenosa* 66pp66, 66pp69, 66pp67 and *Capsella bursa-pastoris* 68pp61, 68pp71 and 68pp64 were all very similar to one another (Fig. 3.1.2.1 b). *Arabidopsis thaliana* CBF4 and *Barbarea vulgaris* (64pp60) were also somewhat similar to this group of *Brassicaceae* sequences however they display greater similarity to one another than to the other members of this group (Fig. 3.1.2.1 b).

A secondary distinct pairing of *Brassicaceae* sequences was seen consisting of sequences *Cardaminopsis arenosa* 66pp77 and *Arabis alpina* 69pp77 (Fig. 3.1.2.1 b).

Capsella bursa-pastoris 68pp75 had a distinct COOH-terminus which was not similar to any other sequence (Fig. 3.1.2.1 b).

All *Ericaceae* samples were very similar to one another; *Vaccinium vitis-idaea* 10pp22, 118pp22, 40pp22, *Vaccinium myrtillus* 114pp22, *Andromeda polifolia* 43pp22C, 43pp22D, 43pp22A, 43pp22B and 18pp22 with the exception of *Empetrum nigrum* 5a, b and c which displayed a different COOH-terminus sequence (Fig. 3.1.2.1 b). This COOH-

terminus sequence did, however, show greater similarity to the other members of the *Ericaceae* than to any other group (Fig. 3.1.2.1 b). 2pp22 *Diapensisa lapponica* and 3pp22 *Arctostaphylos alpina* had identical sequences to *Empetrum nigrum* 5a, b and c (Fig. 3.1.2.1 b).

Two distinct groups of COOH-terminus sequences were seen for *Trifolium repens*, one group consisted of sequences 58pp13, 7pp13, and 94pp3 with almost identical COOH-termini (Fig. 3.1.2.1 b). The second group consisted of sequences 77pp19, 94pp19, 77pp23&24B, 77pp23&24A, which had very similar, but not identical, COOH-termini to one another (Fig. 3.1.2.1 b).

All *Betula nana* sequences were identical to one another (Fig. 3.1.2.1 a-b).

Fragaria vesca 74 (Abisko, Sweden) and 78 (Weardale) had identical sequences (Fig. 3.1.2.1 a-b).

Salix herbacea had two distinct sequences 51pp51 and 51pp53 which had little similarity to one another (relative to all other sequences). 51pp53 had a distinct COOH-terminus which was very different from other species (Fig. 3.1.2.1 b).

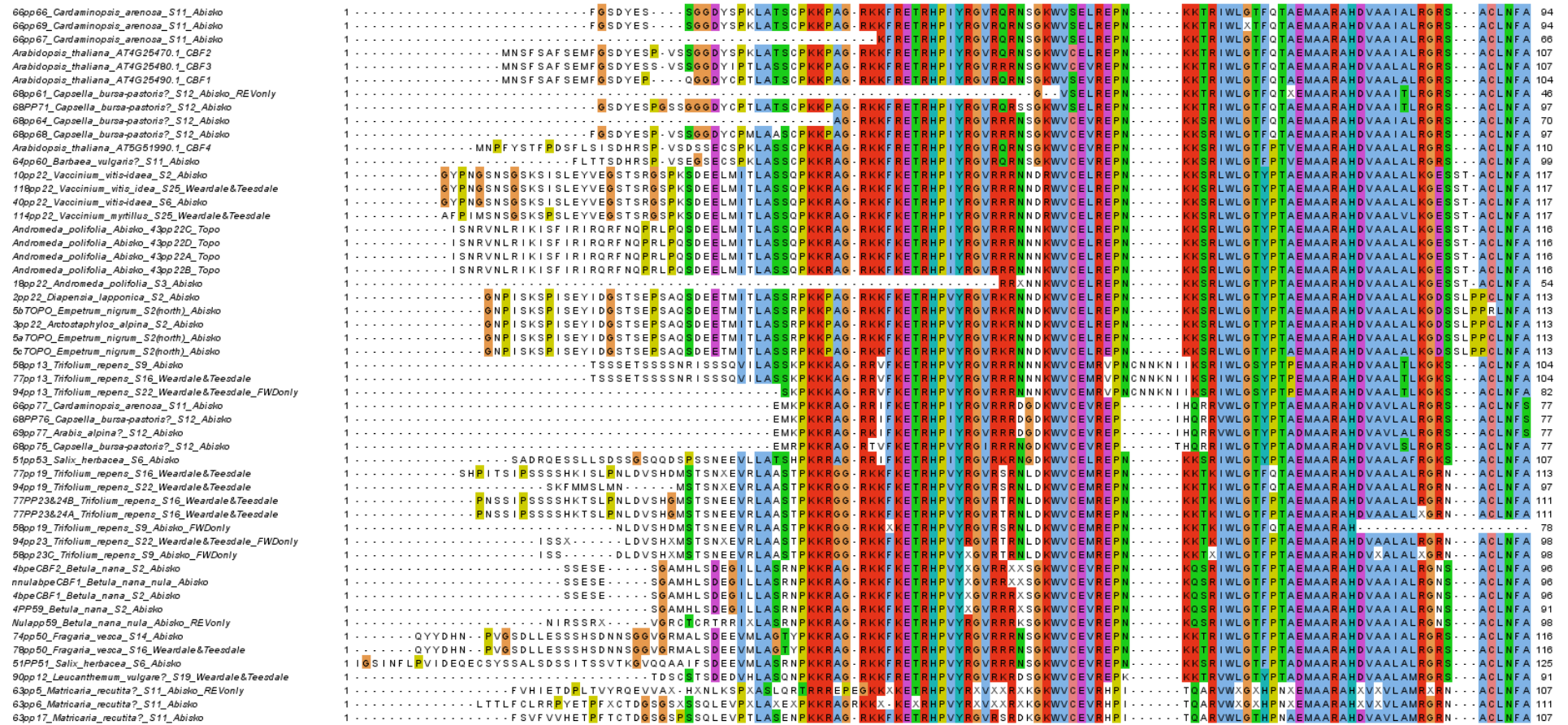

Figure 3.1.2.1.a Clustal alignment of translated CBF nucleotide sequences isolated from collected samples compared to *Arabidopsis thaliana* CBF1-4 genbank sequences. Sequences are ordered by Clustal sorting. Names are in the form “Species code pp primer pair code_Genus_Species_Site code_Location”. Genbank gene names are in the form “Genus_Species_Gene_Genbank code”.

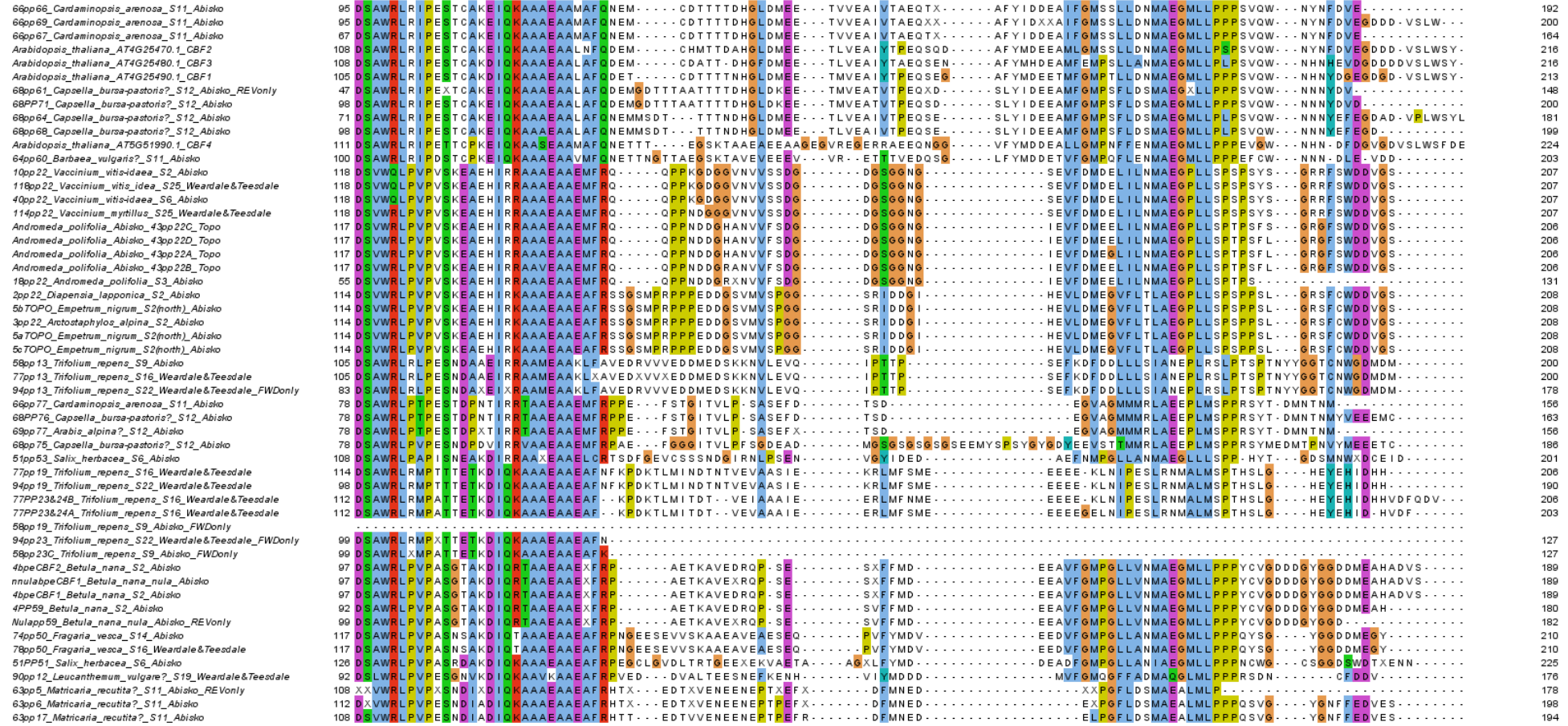

Figure 3.1.2.1 b. Clustal alignment of translated CBF nucleotide sequences isolated from collected samples compared to *Arabidopsis thaliana* CBF1-4 genbank sequences. Sequences are ordered by Clustal sorting. Names are in the form “Species code_UV primer pair code_Genus_Species_Site code_Location”. Genbank gene names are in the form “Genus_Species_Gene_Genbank code”.



Figure 3.1.2.2. Clustal alignment of the CBF signature sequences and AP2 domain only of translated CBF nucleotide sequences isolated from collected samples compared to *Arabidopsis thaliana* CBF1-4 genbank sequences. CBF signature sequences highlighted. Sequences are re-ordered by Clustal sorting. Names are in the form “Species code pp primer pair code_Genus_Species_Site code_Location”. Genbank gene names are in the form “Genus_Species_Gene_Genbank code”.

3.1.2.1 CBF Signature Sequences and the AP2 Domain.

The CBF signature sequences and AP2 domain (the sequence between the CBF signature sequences) was highly conserved across all species (Fig 3.1.2.2).

3.1.2.1.1 Differences Between *Arabidopsis thaliana* CBF1-4 AP2 and CBF Signature Sequences, and Comparison to All Other Sequences.

In *Arabidopsis thaliana* the only differences in the CBF signature sequences and AP2 domain between the 4 CBFs was that CBF4 had an R instead of P (4 amino acids into the CBF signature sequence) and P instead of Q (55 amino acids in) relative to *Arabidopsis thaliana* CBF1-3 (Fig 3.1.2.2). Both of these differences were unconserved.

These two substitutions (R₄ to P and P₅₅ to Q) were seen in multiple species however they were not constant in their pairing (i.e. some sequences had both substitutions and some only had one). The majority of sequences had R rather than P (Fig 3.1.2.2). The exceptions being *Arabidopsis thaliana* CBF1-3, *Cardaminopsis arenosa* 66pp66, pp69, (pp77 has R), *Capsella bursa-pastoris* 68pp 71 and 68 (pp75 and 76 have R), *Diapensia lapponica* 2pp22 *Empetrum nigrum* 5 TOPO(a-c) and *Arctostaphylos alpina* 3pp22 (Fig 3.1.2.2). The three *Trifolium repens* sequences with an insert in the AP2 domain (58pp13, 77pp13 and 94pp13) displayed a substitution not seen in any other at this locus, a conserved (relative to R) substitution to K (Fig 3.1.2.2).

The majority of sequences also had P rather than Q, the exceptions being *Arabidopsis thaliana* CBF1-3, *Cardaminopsis arenosa* 66pp66, pp67 and pp69, *Capsella bursa-pastoris* 68pp61, pp71, pp64 and pp68 and *Trifolium repens* 77pp19, 58pp19, 94pp19 (Fig 3.1.2.2).

3.1.2.1.2 The AP2 Domain

Numerous differences not seen between the four *Arabidopsis thaliana* CBF sequences were seen in the AP2 region when they were compared to all other sequences.

The most notable differences in the AP2 domain were a 6 amino acid insertion (sometimes aligned as two 3 amino acids insertions) seen in *Trifolium repens* 77pp19, 58pp19, 94pp19 (Fig 3.1.2.2) and the different two or three amino acid insertion seen in all *Ericaceae* and *Diapensia lapponica* (Fig 3.1.2.2).

3.1.2.1.3 The N terminus CBF signature sequence

Aside from the previously discussed R to P substitution 4 amino acids into the sequence (Section 3.2.1.1), two other differences in the N-terminus CBF signature sequences were seen. There was an unconserved substitution at amino acid 10, the majority of sequences had K at this point (including all *Arabidopsis thaliana* sequences) however some sequences had either I or V (Fig 3.1.2.2). Those sequences with I were *Cardaminopsis arenosa* 66pp77, *Capsella bursa-pastoris* 68pp76, *Arabis alpina* 69pp77 and *Salix herbacea* 51pp53 (Fig 3.1.2.2). Those sequences with V were *Trifolium repens* 58pp13 and 77pp13 and *Capsella bursa pastoris* 66pp66 (Fig 3.1.2.2).

A conserved R to K substitution at amino acid 12 occurs in all non-*Brassicaceae* species except *Salix herbacea* 51pp51 (note *Salix herbacea* 51pp53 has this substitution) and *Leucanthemum vulgare* 90pp12 (Fig 3.1.2.2). Several *Brassicaceae* also show this substitution namely *Cardaminopsis arenosa* 66p77, *Capsella bursa-pastoris* 68pp76, 68pp75 and *Arabis alpina* 69pp77 (Fig 3.1.2.2).

3.1.2.1.4 The C-Terminus CBF Flanking Sequence

The C-terminus CBF flanking sequence consists of five amino acids (DSAWR in *Arabidopsis thaliana*). D was conserved across all species (Fig 3.1.2.2). S was either conserved or unknown (X) across all species (Fig 3.1.2.2). A was mostly conserved across all species with the conserved amino acid substitution V (All *Ericaceae*, *Diapensia lapponica* and *Matricaria recruta*) or L (*Leucanthemum vulgare*) also seen (Fig 3.1.2.2). W was conserved across all species (Fig 3.1.2.2). R was conserved across all species

except for the unconserved substitution of Q in all *Vaccinium vitis-idaea* sequences (Fig 3.1.2.2).

3.1.3 *MATK* sequences

MATK sequences were isolated from several samples to check for the possibility of contamination, following the sequencing of identical *CBF* sequences (matching that of an *Empetrum nigrum* *CBF* sequence) from all *Calluna vulgaris* DNA extracted prior to a certain date. It was not possible to isolate *CBF* from DNA extracted or re-extracted on subsequent dates (data not shown). Sequence 173_C.vulgaris_NagsHead_MATK (amplified from the older DNA extraction) displayed 100 % identity to *Empetrum nigrum* *MATK* sequences rather than the expected *Calluna vulgaris* sequence (Fig 3.1.3.1 a-c). All other *Calluna vulgaris* sequences were obtained from subsequent DNA extractions and did not match the *Empetrum nigrum* *MATK* sequences and had a unique sequence. This sequence had high similarity to the complete *MATK* coding sequence for *Calluna vulgaris* (U61326.1) from the NCBI database with a few differences (Fig 3.1.3.1 a-c) (see section 3.1.3.1 for further details).

The isolated *Phyllodoce caerulea* *MATK* sequence predominantly matched the NCBI (U61318.1) sequence, with two key differences. In the NCBI sequence there was an insertion of a G that was not seen in the isolated *Phyllodoce caerulea* sequence or any other aligned *MATK* sequence (Fig 3.1.3.1b). Eight bases downstream from this the NCBI sequence also had a deletion of a T that is present in all other *MATK* sequences (Fig 3.1.3.1b). Several substitutions also occur towards the end of the sequence (Fig 3.1.3.1b) whilst they differ from one another, these substitutions are seen in other *MATK* sequences (Fig 3.1.3.1b).

Cassiope tetragona showed 100 % identity between the isolated sequence, from Abisko, Sweden, and the NCBI sequence (KC474423.1), from Canada.

All *Empetrum sp.* sequences had 100 % identity to one another (Fig 3.1.3.1 a-c). This includes sequences sampled from across the UK, Abisko; Sweden, Canada and Boston; North America (N.B. the North American sample was from the Harvard arboretum so could have originally been collected from elsewhere). This includes MATK sequences from two samples recorded as *Empetrum hermaphroditum* (also referred to as *Empetrum nigrum subsp. hermaphroditum*) all others being *Empetrum nigrum* (also referred to as *Empetrum nigrum subsp. nigrum*) (Please see discussion section 5.2.6 on nonclamature and identification of *Empetrum nigrum & hermaphroditum*).

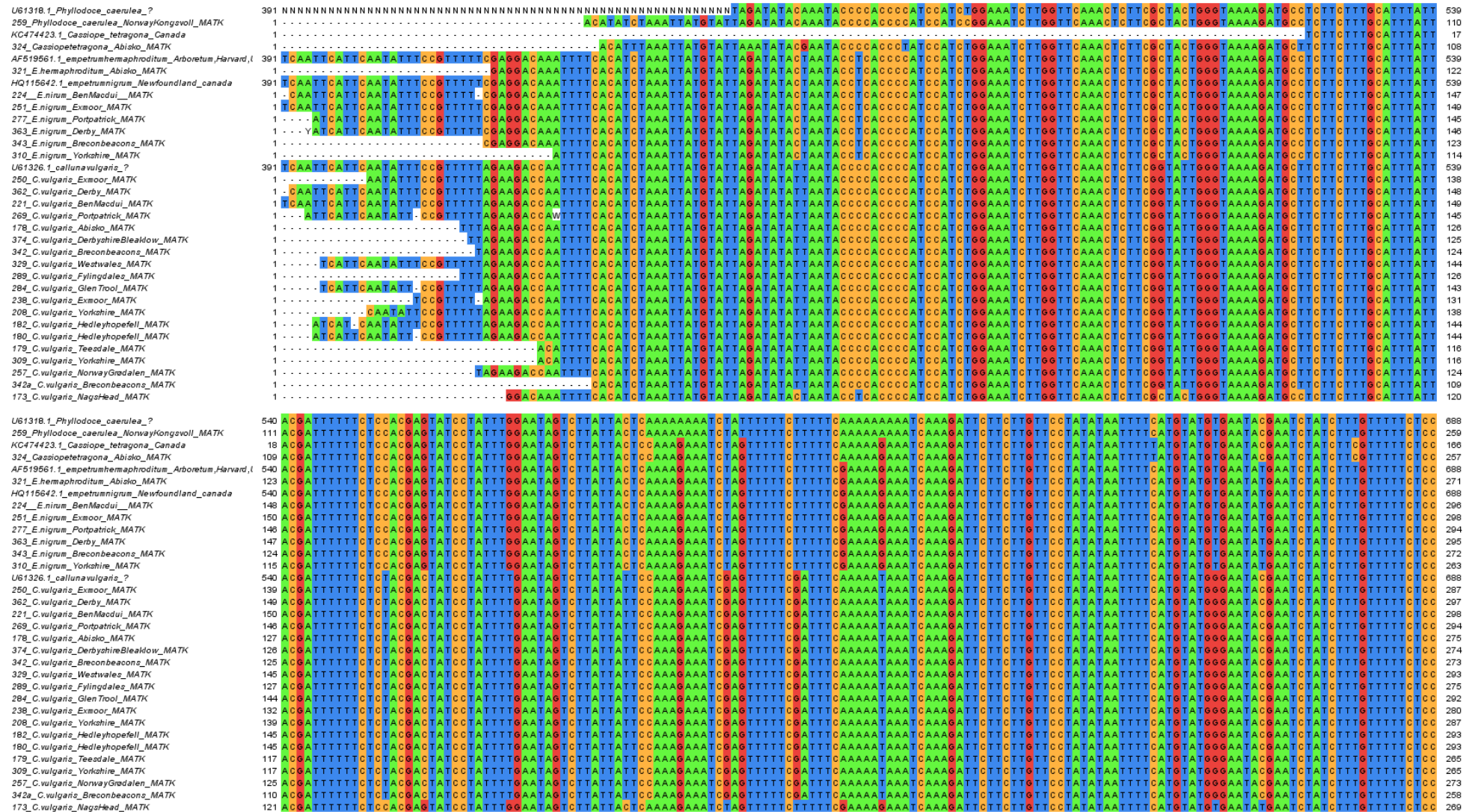

Figure 3.1.3.1 a. Clustal alignment of MATK nucleotide sequences from collected Ericaceae samples compared to one another and NCBI sequences. Only the section of NCBI sequences that are cover the sequenced section from collected samples is shown. Names are in the form genbank Code (NCBI sequences) or species code (study samples)_Species_Location (where known)

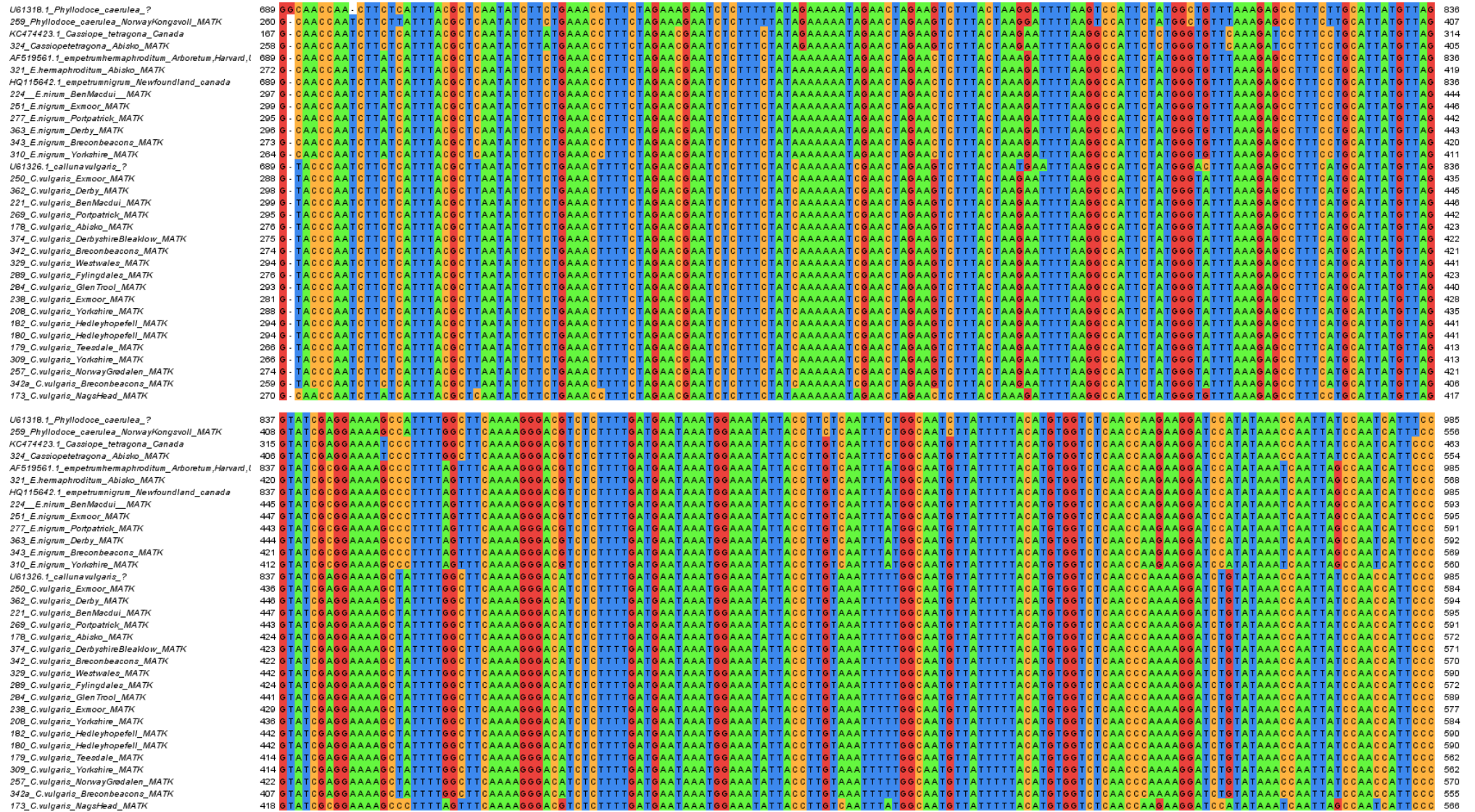

Figure 3.1.3.1 b. Clustal alignment of MATK nucleotide sequences from collected *Ericaceae* samples compared to one another and NCBI sequences. Only the section of NCBI sequences that are cover the sequenced section from collected samples is shown. Names are in the form genbank Code (NCBI sequences) or species code (study samples)_Species_Location (where known)

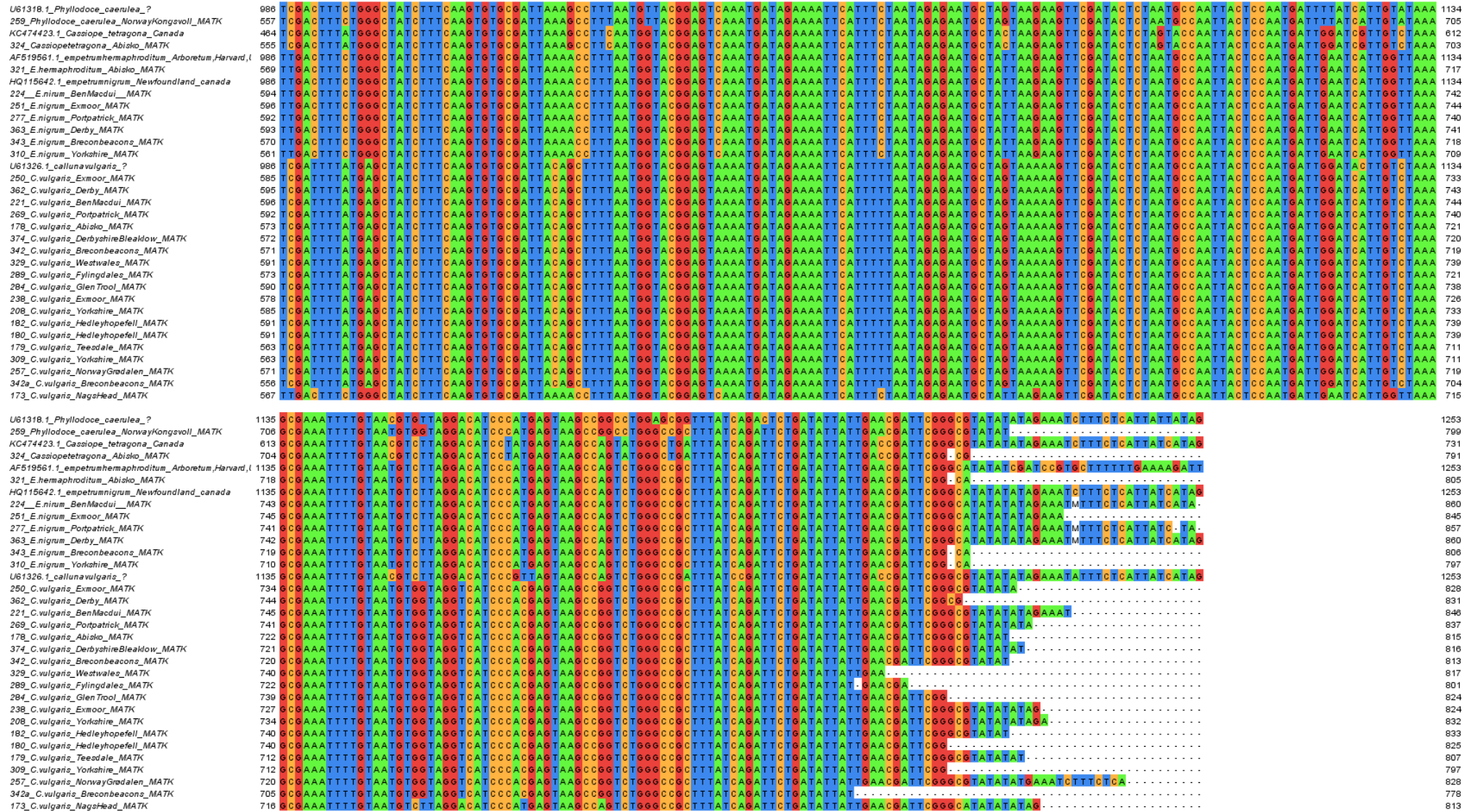

Figure 3.1.3.1 c. Clustal alignment of MATK nucleotide sequences from collected *Ericaceae* samples compared to one another and NCBI sequences. Only the section of NCBI sequences that are cover the sequenced section from collected samples is shown. Names are in the form genbank Code (NCBI sequences) or species code (study samples) Species_Location (where known)

3.1.3.1 Collected vs NCBI Database *Calluna vulgaris* Sequences

The *Calluna vulgaris* MATK sequences from the more recent DNA extractions did not perfectly match the MATK complete coding sequence from NCBI (U61326.1) (Fig 3.1.3.1 a-c). Therefore, they were also compared to all *Calluna vulgaris* MATK partial sequences on the NCBI database and the location of collection for all sequences was noted (Fig. 3.1.3.1.1a-c). Alignments showed that all sequences were very similar except between ~ base 783-807 (relative to the full coding sequence) and from from ~base 1148 (relative to the full coding sequence) to the end of the sequence (Fig. 3.1.3.1.1b). Two distinct sequence types were seen; there was the sequence common to the complete coding sequence (U61326.1), sequences from Portugal (HM850861.1) and Italy (HE966891, HE966890 and HE966889). The other sequence was common to samples from the UK (JN895888.1, JN895864.1 and JN894846.1), Denmark (KX821257, KX821258, KX821259 and KX821260) and collected samples from the UK, Northern Sweden and Norway (samples 250, 362, 221, 269, 178, 374, 342, 329, 289, 284, 238, 208, 182, 180, 179, 257, 309 and 342a). The specimen used by Kron (1997) to get a complete coding sequence which matched samples from Portugal and Italy, but not the UK or Scandinavia was vouchered as coming from the Royal Botanic Gardens Edinburgh. Upon querying this with the Royal Botanic Gardens Edinburgh we were directed to the record of this plant (Data.rbge.org.uk/living/19721433) where it was recorded as the cultivar “Rannoch” and not wildtype *Calluna vulgaris*.

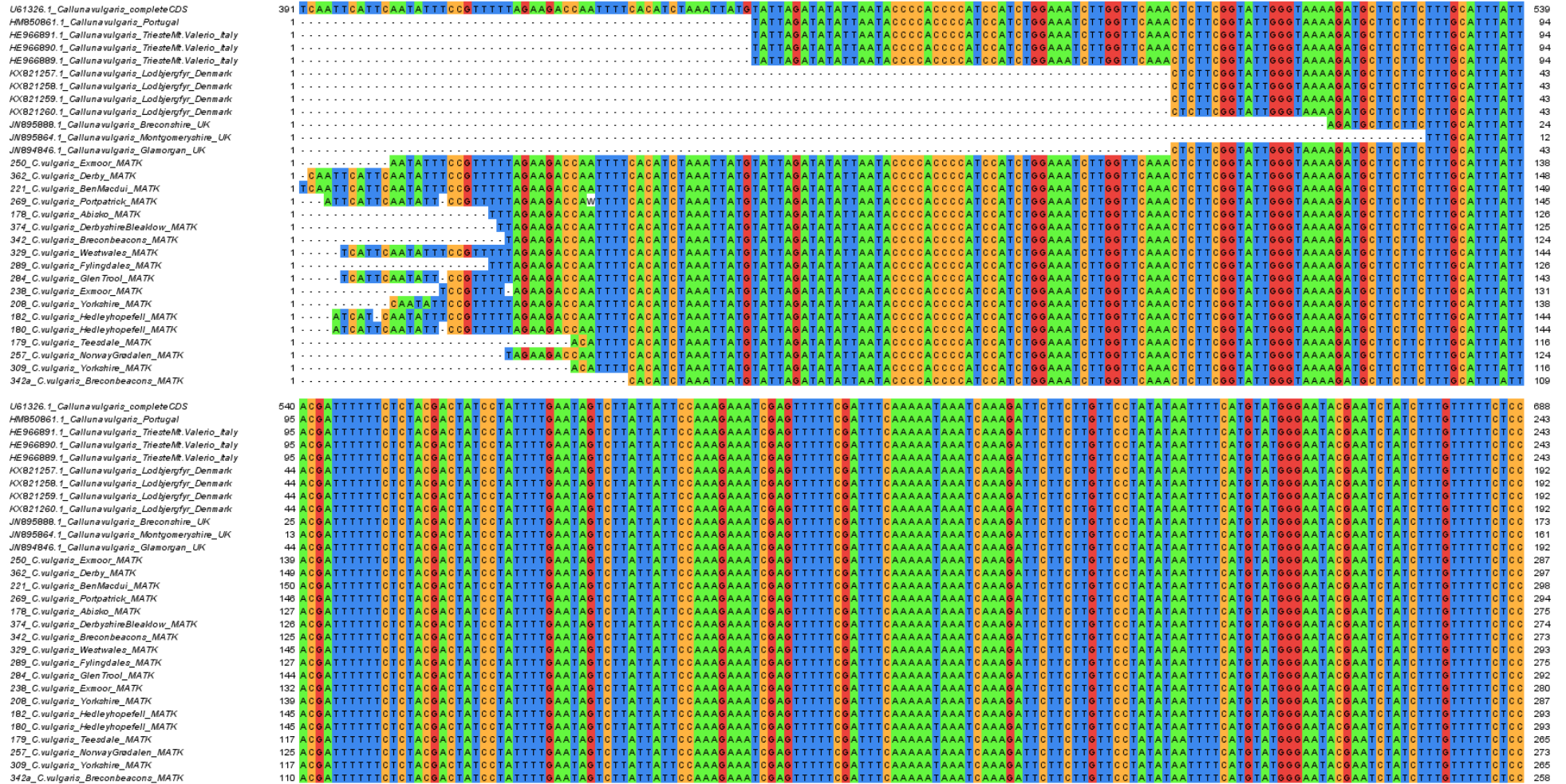

Figure 3.1.3.1.1.a Clustal alignment of all *Calluna vulgaris* MATK nucleotide sequences available from NCBI at the time of writing with sequences from study samples. Sample 173 (previously identified as incorrect – section 3.2.2) has been removed from the analysis. The NCBI full coding sequence is only showing the section of sequence comparable to the other sequences, starting at base 391. Names are in the form genbank Code (NCBI sequences) or species code (study samples)_Species_Location (where known)

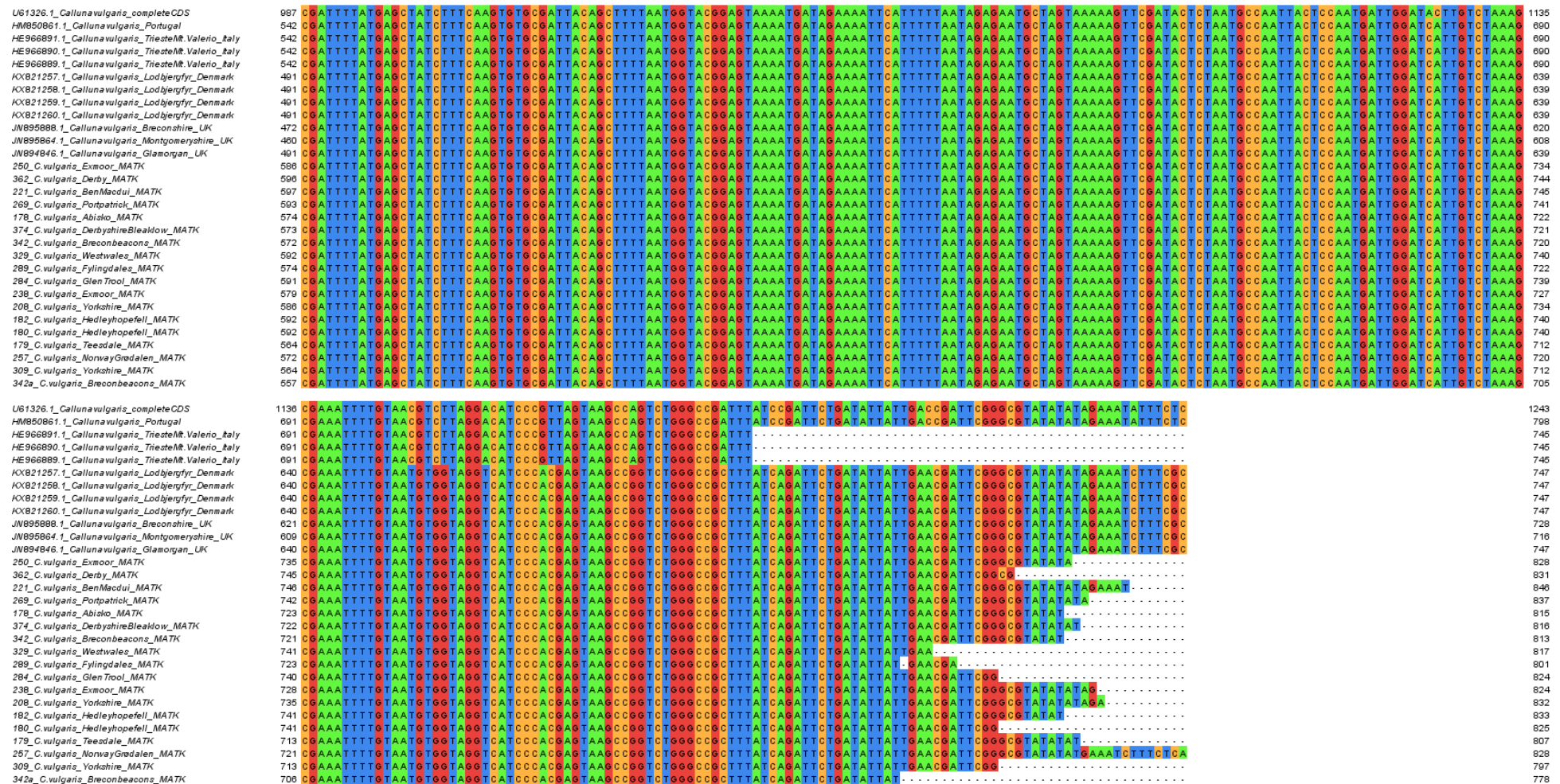

Figure 3.1.3.1.1 c. Clustal alignment of all *Calluna vulgaris* MATK nucleotide sequences available from NCBI at the time of writing with sequences from study samples. Sample 173 (previous identified as incorrect – section 3.2.2) has been removed from the analysis. The NCBI full coding sequence is only showing the section of sequence comparable to the other sequences, starting at base 391. Names are in the form genbank Code (NCBI sequences) or species code (study samples)_Species_Location (where known)

3.2 Discussion

3.2.1 *CBF* Sequences

3.2.1.1 *CBF* Amplification

There are several possibilities as to why *CBF* sequences could not be amplified from numerous species. One possible factor is DNA quality; one of the risks with samples from highly freezing tolerant species being DNA degradation in the -80 °C freezer. Many arctic species can survive when exposed to temperatures of -80 °C and below (Yamori et al., 2005, Stushnoff and Junttila, 1986), including several of the species sampled. Prior to acclimation, freezing tolerance is greatly reduced (Yamori et al., 2005). However, samples collected included species about which there are little to no data on their freezing tolerances and the impact of acclimation. Samples were collected in July at a point when late frosts were over and plants were most likely to have deacclimated. All DNA extracted showed single clear bands when run on an agarose gel, indicating that no DNA degradation had occurred and therefore -80 °C was sufficient to stop or greatly slow metabolic activity in the collected samples. Therefore, DNA degradation is unlikely to have resulted in the failure to isolate *CBF* sequences. Another possibility is that of contaminants inhibiting PCR: Arctic and alpine species have a propensity to contain high levels of phenolic compounds, likely due to the environmental pressures such as cold, UV and herbivory which can all increase plant phenolics (Semerdjieva et al., 2003, Rivero et al., 2001, Hartley and Firn, 1989), which can inhibit PCR reactions (Maltas et al., 2011, Paterson et al., 1993, Guillemaut and Maréchal-Drouard, 1992, Couch and Fritz, 1990). The KAPA3G Plant PCR Kit claims to contain a novel DNA polymerase with improved tolerance to PCR inhibitors such as polyphenolics and polysaccharides (KapaBiosystems, 2015). Many samples that previously did not produce any amplification with normal TaQ polymerase did indeed amplify with KAPA3G plant polymerase, indicating that PCR

inhibitors were present in many DNA samples. However, *CBF* sequences still could not be amplified from numerous species indicating that either the inhibitor content might have been too high or that other factors were also affecting amplification.

Another possibility are the primer sequences themselves: The majority of collected samples did not have previously sequenced *CBF* genes or even members of the same genera with previously sequenced *CBFs*. Therefore, primers had to be designed based on *CBF* sequences from familial relatives of samples or, occasionally, a higher taxon level. Primers were designed to the 5' and 3' end of known *CBF* coding sequences. The 3' and 5' ends are not highly conserved, even between family members (e.g. Fig.2.5.1.1). The 5' end, to which the forward primers are designed, has not been identified as important in *CBF* function, hence mutations in this region are less likely to affect protein function and this region is, therefore, not likely to be subject to active selection to minimise mutations. The 3' terminus, to which reverse primers were designed, has been identified in likely having gene activation function in *CBF* proteins (Wang et al., 2005). However, it shows high functional redundancy and limited conservation (Wang et al., 2005), (primer design alignments – data not shown). This high variation in the 3' and 5' regions reduces the probability of having similar 3' and 5' *CBF* sequences between differing species (the probability decreasing further as species diverge). Therefore, primers designed to these ends have a decreasing probability of amplifying *CBF* sequences the further diverged the test species is from the species the primers were designed from. This likely explains the majority of failed PCR reactions.

3.2.1.2 *CBF* Sequence Quality

Several sequences failed quality control due to poor sequence data (data not included). There were several probable reasons for these failures, namely copy number, ploidy and heterozygosity. Typically, sequences failed due to multiple overlapping base peaks, the

pattern displayed being typical of several sequences overlapping (Personal Obs.). This is highly likely to be occurring given that different genes from the *CBF* family are often around the same size (e.g. *Arabidopsis thaliana* *CBFs* 1-4) and that the sample species are wild and therefore not necessarily homozygous (they may also have a large ploidy number). This is further supported by raw BLASTX (Altschul et al., 1990) data (data not shown) where the majority of sequences that failed quality control all still showed similarity to *CBF* sequences. Despite the inaccuracy of automatic base calling in these sequences it is likely that small sections of conserved identifiable regions, were sufficiently clear across the multiple overlapped sequences which the BLASTX (Altschul et al., 1990) search was able to detect. Those that did not show similarity to *CBFs* with a BLASTX search (Altschul et al., 1990) typically did not show any similarity to anything in the database. There are a couple of possibilities for the overlapping sequence effect in these cases. The overlapping sequences could be multiple *CBF* family genes that happen to differ slightly in size, due to insertions or deletions, but insufficiently different to be seen on a gel, this would result in misalignment of the conserved recognisable areas so raw data would not show these areas clearly. The multiple sequences could also be other similar size sections of non *CBF* family genes also amplified by the primers, but the likelihood of these other DNA sections being the same size as the expected *CBF* product is low. The multiple sequences could also consist of *CBF* gene relatives of similar size (such as other members of the AP2 family) or a *CBF* gene paralogue which has not required maintenance of the typical conserved regions due to taking on a different genetic function. It was thus expected that sequencing PCR products from wild samples with primers designed to amplify members of a gene family would produce overlapping sequences, as appears to have occurred. However, by sequencing straight from PCR products, samples with multiple sequences in these products could be identified for future isolation of sequences via cloning.

3.2.1.3 *CBF* Nucleotide Sequences

There is a great deal of variation in the nucleotide sequence of *CBFs*, isolated from various samples (Fig. 3.1.1.3.1 a-c, Fig. 3.1.1.2.1 a-b and Fig. 3.1.1.1.1). When these sequences are sorted via Clustal (Larkin et al., 2007) they form family groups (Fig. 3.1.1.3.1 a-c, Fig. 3.1.1.2.1 a-b and 3.1.1.1.1). Indicating that the difference in *CBF* nucleotide sequence has more to do with evolutionary relatedness of the species than freezing tolerance. This familial grouping also indicates that the various *Arabidopsis thaliana* *CBF*1-4 have more in common with one another and other Brassicaceae *CBFs* than *CBFs* from different families, indicating the divergence of *CBF* 1-4 occurred after the split of the Brassicaceae from the other families studied here, as supported by Xiong and Fei (2006).

It should be noted that some species identifications are tentative (those marked with a “?”) and therefore their species identification is not certain, although the genus is highly likely to be correct. In some cases, this is due to the presence outside of the expected distribution of that plant. In others, slight morphological differences (possibly due to environmental stress or subspecies) hindered identification and several identifications were made upon vegetative tissue only further hindering identification at the species level.

3.2.1.3.1 Brassicaceae

Unlike Xiong and Fei, (2006) *CBF*1-3 of *Arabidopsis thaliana* did not group together separately from all other Brassicaceae. However, it should be noted that Xiong and Fei, (2006) only used the species *Brassica napus* and *Capsella bursa-pastoris*. The *Cardaminopsis arenosa* sequences from this study are interspersed between *Arabidopsis thaliana* *CBF*1, 2 and 3 showing greater similarity to individual *A. thaliana* *CBFs* than to other *CBF* sequences from the same species (Fig. 3.1.1.1.1), indicating that *CBF*1-3 divergence occurred before the split of these two species. This fits with some

phylogenetic studies, suggesting *Cardaminopsis* is nested within *Arabidopsis* genus (Yang et al., 1999). Indeed *Cardaminopsis* has recently been moved to the *Arabidopsis* genus (Kew, 2013). It therefore seems likely that the split of *CBF1*, 2 and 3, and their differentiation, occurred within the *Arabidopsis* genus before speciation of *A. thaliana* from *Cardaminopsis arenosa* (aka. *Arabidopsis arenosa*).

Cardaminopsis arenosa also has a *CBF* sequence which is identical to one from *Capsella bursa-pastoris* and highly similar to one from *Arabis alpina* that is not seen in *Arabidopsis thaliana* (Fig. 3.1.1.1.1). Since *Arabidopsis thaliana* is fully genome sequenced, that it does not have this sequence is not due to a failure to isolate it. That this sequence is present in multiple genera, including *Arabidopsis* (to which *Cardaminopsis* is now assigned) but not *Arabidopsis thaliana* suggests that it was possibly an ancestral sequence which has been lost or heavily modified in *Arabidopsis thaliana*.

A sequence was isolated from *Barbarea vulgaris* which had high similarity to *Arabidopsis thaliana CBF4*. Both these sequences were distinctly different from all other sequences (Fig. 3.1.1.1.1). It is therefore likely that these two sequences share a common ancestor, likely branching before *A. thaliana CBF* 1-3 differentiated from one another, this is supported by Xiong and Fei, (2006) who found that *Arabidopsis thaliana CBF4* differentiated before the split of *A. thaliana CBF* 1-3. It is therefore possible that, like *Arabidopsis thaliana CBF4* (Haake et al., 2002), the *CBF* isolated from *Barbarea vulgaris* by primer pair 60 is induced by drought rather than cold, assuming that the change in regulation occurred early in the differentiation of *CBF4* from *CBF1-3*.

The Brassicaceae family had more *CBF* sequences per species than all other families studied. However, this is likely to be an artefact of the ability to produce primers to already known *CBF* sequences, as this family has a great deal of genetic study performed on it as well as containing multiple crop species and the model plant species *Arabidopsis*

thaliana. Eighteen primer pairs were produced for the Brassicaceae family, whereas only 1-2 primer pairs could be produced for the majority of the other families (for example Ericaceae only had one primer pair that could be designed for amplification of *CBF*).

3.2.1.3.2 Ericaceae

There is less variance between sequences in the *Ericaceae* family than in the *Brassicaceae* family. This is likely due to 1 primer pair being used to isolate and amplify *CBF* as opposed to 18 primer pairs in Brassicaceae rather than being truly representative of less diversity within the Ericaceae.

Four subtly different, but highly similar, *CBF* sequences were isolated from *Andromeda polifolia* sample 43. This is unlikely to be due to different alleles as they would show as one singular band when run on a gel with overlapping sequence data resulting in degenerate bases. However, gene duplication in tandem could result in the different banding patterns seen but similar sequencing results; amplification may continue past the end of one *CBF* gene into another resulting in different reannealing patterns. This would explain the banding pattern seen namely a band of expected size (1 *CBF* strand + 1 *CBF* strand) a larger band (a 1 ½ size band: 1 *CBF* strand + double *CBF* strand) and an even larger band (a 2X band: double *CBF* strand + double *CBF* strand) and possibly a fourth larger band (1 *CBF* strand + 3 *CBF* strands). Only bands between ~400-1500bp were sequenced so if more than 2-3 repeats existed, they would not have been sequenced, nor were they likely to be amplified due to a typical *CBF* sequence being ~600bp long and the probability of successful amplification dropping off as length increases. This would also explain why, when sequenced, all bands of different sizes gave sequence products of the same size and highly similar sequence. The occasional different base-pair would not disrupt sequencing and, given that typical sequence reads were less than 600bp long (the forward and reverse being amalgamated to form the full sequence), if sequences were sufficiently similar (as implied) the beginning of 1 *CBF* may have been combined with

the end of a second *CBF* in the tandem sequence. Tandem arrangement of multiple *CBFs* is a likely possibility as tandem alignment of varying copy number of *CBF* genes is common for example such as seen in *Arabidopsis thaliana* (Gilmour et al., 1998, Medina et al., 1999), *Medicago truncatula* (Tayeh et al., 2013) *Lolium perenne* (Xiong and Fei, 2006) *Prunus perscia* (Wisniewski et al., 2011) and *Triticum monococcum* (Miller et al., 2006). Frequent duplication of the *CBF* gene is also believed to have been a common occurrence as supported by the *CBF* phylogenetic study by Xiong and Fei, (2006). Greater *CBF* copy number has been linked with increased winter hardiness in barley and wheat cultivars (Knox et al., 2010, Wurschum et al., 2017) so multiple *CBF* copy numbers in highly freezing tolerant plants (as studied here) would be likely.

A similar situation as seen in *Andromeda polifolia* (namely multiple copy number of *CBF* in tandem) is likely to also be occurring in *Empetrum nigrum* as multiple banding patterns were also observed for this species with all bands giving similar sequence reads. If multiple copy number of *CBF* increases winter hardiness, as suggested by Knox et al., (2010) and Wurschum et al., (2017) this could also explain the association of tetraploids of *Empetrum nigrum* (often identified as *Empetrum nigrum subsp. hermaphroditum*) with more cold environments (see section 5.2.6 “A note on *Empetrum nigrum* subspecies”) as an increase in ploidy level would be a rapid way to increase *CBF* copy number and would certainly merit further study.

That the sequences from *Arctostaphylos alpina* and *Diapensia lapponica* were identical to one of the *Empetrum nigrum* sequences is highly suspicious, especially given that *Diapensia lapponica*, although closely related to the *Ericaceae*, is not a member of the *Ericaceae* (included in the *Ericaceae* lineup here due to identical sequence). This is the same sequence as found in the *Calluna vulgaris* samples (removed and not shown) that showed 100 % identity to *Empetrum nigrum* MATK sequences. MATK sequences were not successfully checked from these two samples, so it is therefore possible that they

suffer from the same contamination as some of the *Calluna vulgaris* sequences and therefore the validity of their *CBF* sequence is highly suspect.

The high similarity in *CBF* sequence between the two *Vaccinium* species would indicate that the *CBF* gene sequenced has a recent common ancestor however differentiation has occurred between the species.

3.2.1.3.3 All Other Species

There is a great deal of variance in nucleotide sequence between different species from different families. Given the variance seen within families (see section Ericaceae and Brassicaceae) this high variance across families is unsurprising.

The *Trifolium repens* sequence containing an 18 base insert not seen in any other species but seen across *Trifolium repens* samples from both Sweden and the UK indicates that this insert is not a recent mutation that has occurred and is specific to a local area, but that it has been retained by *T. repens* from differing locales alongside *CBF* sequence(s), in the same plant, without this insertion. This would indicate that, if it does not have functional activity, it is not a detrimental mutation. That the insert is 18 bases long (divisible by 3) indicates that it may be functional as no shift in reading frame occurs as a result. (This mutation is further discussed in the translated sequence section).

There has been no differentiation in the *CBF* sequence between *Fragaria vesca* from the UK and Sweden, indicating that no modification, to this particular sequence has occurred in response to differing environments.

Two highly distinct (both form one another, and other sequences) *CBF* sequences were isolated from *Salix herbacea*. Although distinct from *CBF* sequences isolated within this project a high similarity to *CBF* sequences from *Populus* species was found when MegaBLAST was performed (Morgulis et al., 2008). *Populus* is a highly studied genus within the *Salicaceae* of which *Salix herbacea* is another member. Unlike most other

families (where 1-2 was standard (section 2.5.1.1)) 7 primer pairs were able to be produced to attempt to amplify *CBF* from members of the *Salicaceae*. This is likely why two highly different sequences were able to be isolated from *Salix herbacea*, as with members of the Brassicaceae (see section 3.2.1.3.1), the greater number of primers is likely the cause of the isolation of very different *CBF* sequences from the same species rather than these species being the only ones with multiple highly differentiated *CBF* sequences.

All *Matricaria recutita* sequences, from the same sample, are very similar bar some degenerate bases and variation at the start and end of the sequence. This could either indicate that there are several *CBF* sequences with subtly different initial and terminal sequences (that result in different primer pairs binding) or that all primer pairs bound to the same sequence but there are some errors in the sequence read. Only the reverse sequence amplified by primer pair 5 produced a clear useable sequence read and this is also the sequence with apparent insertions in the sequence briefly changing the reading frame, it therefore seems likely that this is due to poor sequence reading towards the end of the reverse sequence (i.e. the start of the *CBF* sequence) rather than true insertions. However, the other two sequences read well in both the forward and reverse directions. Since all sequence chromatograms were manually checked for degenerate bases and correct basal calls, it seems more likely that there are at least two highly similar *CBF* sequences where different primers preferentially bind to one sequence over another. Given that the sequence amplified by primer pair 6 has the same sequence as that amplified by primer pair 17 but with extra degenerate bases (one base of which matches the other sequence amplified by primer pair 17) it is feasible that primer pair 6 is amplifying the same sequence as primer pair 17 alongside another similar but subtly different sequence.

Leucanthemum vulgare, had a *CBF* sequence very similar to that of sample *Matricaria recutita*. This is unsurprising since these are closely related species and both members of the Anthemideae (within the Asteraceae family).

There was a large degree of failed amplification of *CBF* genes from DNA, only successfully amplified sequences which passed quality control are shown in Fig. 3.1.1.3.1 a-c, Fig. 3.1.1.2.1 a-b and Fig. 3.1.1.1.1. No successful amplification was achieved from all other species (Table 2.1.5). The large degree of failed amplification is likely due to the unavailability of sequences of closely related species from which to design primers. As evident from these line ups (Fig. 3.1.1.3.1 a-c, Fig. 3.1.1.2.1 a-b and Fig. 3.1.1.1.1) there is a great deal of variation in nucleotide sequence and therefore the design of primers to the beginning and end sequence of the *CBF* which can amplify non-closely related species was not possible. Primers which were used to attempt to isolate *CBF* sequences from species greater than family level always failed. That there is very little conservation between the beginning and end of the sequence indicates that these regions undergo a great deal of differentiation. If, as discussed in section 3.2.1.3.2, copying of *CBF* genes appears to be common, that would therefore result in more opportunities for variation to occur within the copied genes. Also, as previously discussed, where multiple primers were available different *CBF* sequences were often isolated and therefore that some families only had one primer pair available means that it is likely that other *CBF* sequences were not isolated.

3.2.1.4 Translated CBF Sequences

*Note: as with the results section, comparisons (unless stated otherwise) are made against *Arabidopsis thaliana* CBF1. Therefore, the terms substitution, insertion or deletion are used simply relative to *Arabidopsis thaliana* CBF1; they do not have any evolutionary significance.*

There are two known domains which predominately impact upon the activity of CBF. One of these is the COOH terminus consisting of clusters of hydrophobic residues forming loops, involved in activation activity with high functional redundancy (Wang et al., 2005). Of greater interest, due to the apparent lack of redundancy, is the *COR* binding domain consisting of; the AP2/ERF domain (common to all AP2 gene family members) (Sakuma et al., 2002) and the CBF flanking domains (specific to CBF); PKKP/RAGR_xKF_xETRHP (PKKPAGR) and DSAWR sequences (Canella et al., 2010). Single amino acid mutations in the *COR* binding domain can significantly impact on binding to the CRT/DRE element (Canella et al., 2010, Sakuma et al., 2002). Canella et al., (2010) tested multiple single amino acid mutations within the RKKFR motif (a region predicted to form an α -helix) of the PKKPAGR sequence. K(8) to R (conserved) and A (non conserved), K(9) to R (conserved) and A (non conserved) and R(11) to S (non conserved); all had no significant effect on binding (Canella et al., 2010). Substitution of R(7) with either K (conserved) or S (non-conserved) significantly impaired binding. Substitution of F(10) with A or P (non-conserved) abolished binding and substitution with Y (conserved) greatly enhanced binding (Canella et al., 2010). Another amino acid that was found to be key to binding is V(14) in the AP2/ERF domain, a conserved substitution to A which prevents binding to the DRE/CRT element of *COR* genes (Sakuma et al., 2002). Therefore, naturally occurring amino acid substitutions within the CBF flanking sequences, and to a lesser extent the AP2/ERF domain, were of interest for their potential effect upon CBFs ability to bind, and therefore activate *COR* genes.

One natural substitution which was found in this study, was a substitution of one of the amino acid residues tested by Canella et al., (2010), namely R(11). Canella et al., (2010) artificially substituted this R with S (non conserved) which had no significant effect on binding. However, the naturally occurring substitution was a conserved substitution of R to K. This was found in all non-Brassicaceae, bar one of the *Salix herbacea* sequences

which also had R (Fig. 3.1.2.2). This substitution was therefore selected for further study. Other naturally occurring substitutions of interest were found in the DSAWR flanking region, which had not previously been tested for CRT/DRE binding efficiency. These substitutions (relative to *Arabidopsis thaliana* CBF1) are highlighted in Table 2.5.2.1. With the exception of R to Q (only seen in *Vaccinium vitis-idaea*) all substitutions in this region are conserved substitutions (Fig. 3.1.2.2).

3.2.1.4.1 Full CBF Sequence Comparisons

All translated sequences display the CBF flanking signatures (Fig. 3.1.2.2) indicating that all sequences amplified were CBF sequences and were not other AP2 proteins. Whilst the PKKPAGR sequence of *Matricaria recutita* amplified by primer pair 5 does not match what is expected it is more likely that this is due to the aforementioned read problems which resulted in apparent base insertions (Section 3.2.1.3.3) rather than being an entirely different product.

The majority of difference seen between sequences is in the COOH terminus. Wang et al., (2005) found that there was high functional redundancy in the COOH region where a large number of mutations and disruption of several of the hydrophobic loops were required in order for any impact on activation of *CBF* target genes to occur. Therefore, high variance in this region and even large areas of deletions are unlikely to have a significant effect and similarity is more likely to indicate genetic relatedness than a relatedness in activity. Due to this high redundancy the COOH terminus was disregarded for further study.

Given the greater similarity of *Arabidopsis thaliana* CBF1-3 to one another than to other CBF sequences, and *A. thaliana* CBF4 having greater similarity to *A. thaliana* 1-3 than some other Brassicaceae sequences (namely: *Cardaminopsis arenosa* 66pp77 and *Arabis alpina* 69pp77 and *Capsella bursa-pastoris* 68pp75) and all other species sequences, no

assumptions about activity can be made based upon structural similarity to *A. thaliana* sequences.

3.2.1.4.2 AP2 and CBF Signature Flanking Sequences

The CBF signature sequences and AP2 domain (the sequence between the CBF signature sequences) was highly conserved across all species (Fig. 3.1.2.2). One exception is the six base insertion found in some CBF sequences from *Trifolium repens*. All *Trifolium repens* samples sequenced had a CBF sequence with this insertion as well as a CBF sequence without this insertion. This included samples from both Abisko, Sweden and the North Pennines, UK. This indicates that this CBF with an insertion is common and not a recent local adaptation. That this gene seems to be widespread indicates that it is of at least no negative influence upon *Trifolium repens*. It is unlikely that this insertion improves freezing tolerance as the LT50 of *Trifolium repens* is around -16 °C after acclimation (Svenning et al., 2001, Olsen et al., 2008) this is a much higher temperature than several other species studied here which do not have this insertion (Stushnoff and Junttila, 1986, Yamori et al., 2005). However, it is possible that this gene does have retained functionality given that the insertion maintains the reading frame. How this functionality is affected however is unknown. Binding tests (such as electrophoretic mobility shift assays as exemplified by (Canella et al., 2010)) would have to be performed, synthetic *CBF* genes for transient and stable transformation could also be produced and tested (as described in sections 2.5.2 and 2.8) to analyse the effect of this insertion. However, since this was unlikely to improve freezing tolerance (as previously discussed), and areas of greater interest were identified this was not studied further within this project.

V(14 – counting from the start of the AP2 domain) in the AP2/ERF domain previously identified as key for CBF binding to the DRE/CRT element of *COR* genes (Sakuma et al., 2002) was conserved across all sequences (Fig. 3.1.2.2) .

That CBF4 in *Arabidopsis thaliana* has two unconserved amino acid substitutions in the AP2 & CBF signature sequences (an R instead of P, 4 amino acids into the CBF signature sequence and P instead of Q, 55 amino acids in) relative to CBF1-3 is likely a reflection of its evolutionary history; diverging from the progenitor of CBF1-3 prior to the differentiation of CBF1-3 (Xiong and Fei, 2006) (and as discussed in section 3.2.1.3.1). That the majority of sequences from all species had R (4) rather than P(4) and P(55) rather than Q(55) (Fig. 3.1.2.2) could indicate that R(4) and Q(55) is the ancestral state i.e. that P substituted R (4) and Q substituted P (55) in the progenitor of *A. thaliana* CBF1-3 after the split of the progenitor of *A.thaliana* CBF1-3 from CBF4. Therefore, *Cardaminopsis arenosa* 66pp66, pp69 and *Capsella bursa-pastoris* 68pp 71 and 68 sequences (all with the P(4) and Q(55) substitution) likely descended from the same progenitor as *A. thaliana* CBF1-3 after these substitutions occurred and that *Cardaminopsis arenosa* 66pp77 and *Capsella bursa-pastoris* 68pp75 and 76 descended from a different progenitor prior to these substitutions arising. (It should be noted that sequence data does not cover the 4th base of the CBF signature sequence for sequences *Cardaminopsis arenosa* 66pp67 and *Capsella bursa-pastoris* 68pp61. It is therefore unknown which amino acid is at this location). This evolutionary history is supported by the similarity in nucleotide sequences. However, these substitutions have likely occurred more than once as *Diapensia lapponica* 2pp22, *Empetrum nigrum* 5 TOPO(a-c) and *Arctostaphylos alpina* 3pp22 (Fig. 3.1.2.2) also have the P(4) rather than R(4) but not the Q(55) rather than P (55) substitution, the rest of the sequence (both amino acid and nucleotide) also shows greater similarity to other members of the *Ericaceae* than to any member of the *Brassicaceae* indicating a separate substitution event. *Trifolium repens* 77pp19, 58pp19, 94pp19 conversely has the

Q(55) substitution rather than the P (55) substitution but not the P(4) rather than R(4) substitution indicating a separate mutation event for p(55) to Q(55). The three *Trifolium repens* sequences with an insert in the AP2 domain 58pp13, 77pp13 and 94pp13 also displayed a substitution not seen in any other at the R(4) locus; a conserved (relative to R) substitution to K (Fig. 3.1.2.2). Multiple substitution events at this site suggests that either this is a locus of little import, where substitutions have little to no effect upon binding ability of CBF or, since the same substitutions occur multiple times, it is more likely that there is convergent evolution at this site and that these substitutions do confer a different binding behaviour or protein stability. Unfortunately, no comparison between the binding strength or stability of CBF4 vs CBF1-3 in *A. thaliana* has been undertaken by way of comparison. There is, however, no link between these substitutions and the freezing tolerance of the species with these mutations. The presence of these substitutions alongside CBFs without these substitutions within the same plant combined with the lack of a link between these substitutions and the freezing tolerance of the species studied, indicated a lack of role in altering freezing tolerance. Therefore, substitutions more likely to affect freezing tolerance were preferentially studied and these particular substitutions (described above) were not further investigated.

As well as the aforementioned P/R(4) site common substitutions, K(10) also seems prone to substitutions namely the unconserved substitution to I and V seen in some *Brassicaceae* and *Trifolium repens* sequences. This is in the RKKFR motif predicted to form an α -helix (Canella et al., 2010) however conserved (R) and non-conserved (A) substitutions performed at this position in *Arabidopsis thaliana* CBF1 were previously found to have no significant effect on binding (Canella et al., 2010). It seems therefore likely these naturally found substitutions also have no effect upon binding.

That all species studied excluding some members of the Brassicaceae (including all *Arabidopsis thaliana* sequences), one of the *Salix herbacea* sequences and the

Leucanthemum vulgare sequence, have K rather than R at amino acid 12 is extremely interesting. Canella et al., (2010) performed a non-conserved substitution of this amino acid in *Arabidopsis thaliana* CBF1 which resulted in no change in binding. However, no conserved substitution, as observed, was tested. Given that substitution of the neighbouring F with a conserved amino acid greatly enhanced binding (Canella et al., 2010) it is possible that this conserved change could influence binding and therefore the level of activation of target genes. This substitution was therefore selected for further analysis and generation of a synthetic *Arabidopsis thaliana* CBF1 gene containing this substitution performed.

3.2.1.4.3 The C-Terminus CBF Flanking Sequence

The CBF flanking sequence (known as DSAWR due to the sequence in *Arabidopsis thaliana*) has not been previously studied with regards to how substitutions may affect binding. The majority of the sequence was highly conserved across all species. D, S and W were always conserved perhaps indicating that these amino acids cannot change without negative effects upon activity.

A was mostly conserved across all species, however two conserved amino acid substitutions were seen, to V (All Ericaceae, *Diapensia lapponica* and *Matricaria recrutita*) and L (*Leucanthemum vulgare*) (Fig. 3.1.2.2). The effect of this conserved substitution, if any, cannot be predicted, however given that conserved substitutions in the N-terminus AP2 flanking CBF signature sequence have been associated with increased binding (Canella et al., 2010) these substitutions were therefore investigated further via the generation of a synthetic *Arabidopsis thaliana* CBF1 gene containing these substitutions.

R was conserved across all species except for *Vaccinium vitis-idaea* which had a non-conserved substitution of Q at this site. Previous studies of *Vaccinium vitis-idaea* with

this substitution found that this substitution was not present in Chinese samples of *V. vitis-idaea* (Oakenfull et al., 2013). That it is present in both Swedish and UK samples (Fig. 3.1.2.2) indicates that this is a mutation that has been maintained across multiple related populations. Interestingly Oakenfull et al., (2013) found that *V. vitis-idaea* CBF (containing the Q substitution) had greatly reduced ability to activate *COR* genes in *Arabidopsis thaliana*, whereas the almost identical sequence of *V. myrtillus* could (Oakenfull et al., 2013). Further *Vaccinium vitis-idaea* is a highly freezing tolerant species, with no decrease in survival, once acclimated, at -80 °C (Yamori et al., 2005). However, the plant tested by Yamori, et al., (2005) to identify this tolerance was from Mt. Iwo, in the Yatsugatake mountains, Japan (2760 m above sea level) and the CBF amino acid sequence is unknown. *Vaccinium vitis-idaea* from Norway was found to be hardy (LST 66) to -35 °C in December months (Stushnoff and Junttila, 1986). It is likely that this sample does have the Q substitution due to the proximity to Swedish samples. It is therefore possible that the Q substitution does reduce the efficacy of CBF, especially if it is assumed that the Japanese sample, similarly to the Chinese *V. vitis-idaea* does not contain this substitution. However, that other factors involved in freezing tolerance, such as upstream and downstream genes, other *CBF* genes, or other parts of the *Vaccinium vitis-idaea* sequence do result in a high freezing tolerance, even upon reduction in the activity of that particular CBF. Further, it should be noted that two different methods were used to assess freezing damage in *Vaccinium vitis-idaea*; Yamori et al., (2005) used the FDA staining method whereas Stushnoff and Junttila, (1986) used visual estimation and they are therefore they are not directly comparable. The effect of this Q substitution was therefore investigated further, both with the associated A -> V substitution and without, via the generation of a synthetic *Arabidopsis thaliana CBF1* gene containing this substitution.

3.2.2 *MATK* Sequences

There was a strong indication that all *Calluna vulgaris* *CBF* sequences isolated were in fact contaminated with *Empetrum nigrum* DNA, as surmised from the matching *CBF* sequences. Upon amplification of *MATK* from suspected contaminated DNA this was shown to be the case: the *MATK* sequence isolated from *Calluna vulgaris* DNA extracted prior to a certain date had 100 % identity to *Empetrum nigrum* *MATK* sequences and differed greatly from *MATK* sequences isolated from *Calluna vulgaris* DNA extracted after that date (Fig. 3.1.3.1). Therefore, all *CBF* sequences isolated from likely contaminated *Calluna vulgaris* samples were discarded. *CBF* could not be isolated from *Calluna vulgaris* DNA extracted after the suspected contamination date, which had accurate *MATK* sequences, further indicating that contamination had indeed occurred in the previous sample. It also seems likely that the two other samples with 100 % *CBF* sequence identity to *Empetrum nigrum* (*Diapensia lapponica* and *Arctostaphylos alpina*), (Fig. 3.1.1.2.1) also sequenced around the same time as the *Calluna vulgaris* contaminated samples, but upon which *MATK* sequencing was not performed, were also contaminated and therefore should be disregarded from analysis.

The *Calluna vulgaris* *MATK* sequence from later DNA samples did not show 100 % identity to the GenBank *MATK* sequence (U61326.1) (Fig. 3.1.3.1) therefore these differences were investigated further and compared to more published *Calluna vulgaris* sequences. Upon comparison, two groupings of *MATK* sequences were found for *Calluna vulgaris* one common to samples from the UK, Denmark, Sweden and Norway and another from Portugal and Italy which matched the original reference; indicating two distinct and diverging populations. The original reference sequence, which matched sequences from Portugal and Italy was, however, recorded as being wildtype *Calluna vulgaris* coming from the Royal Botanic Gardens Edinburgh (Kron, 1997) this was

incorrectly recorded by the author and the specimen was not wildtype but was the cultivar “Rannoch” (RBG Edinburgh, 2018b). The similarity of the *MATK* sequence of the Rannoch cultivar to wild *Calluna vulgaris* from Portugal and Italy and dissimilarities to those from the UK and Scandinavia (Fig. 3.1.3.1) indicates that the cultivar has ancestry from *Calluna vulgaris* plants outside of the UK or Scandinavia, possibly from southern Europe. The more recent DNA extractions from *Calluna vulgaris* having 100 % match to other *Calluna vulgaris* *MATK* sequences from Scandinavia and the UK further confirmed that the recent DNA extractions from *Calluna vulgaris* were indeed from *Calluna vulgaris* samples and are not DNA contamination by another species.

The GenBank *Phyllodoce caerulea* sequence (U61318.1) had an extra G insertion not present in any other *MATK* sequences including the collected sample of *Phyllodoce caerulea* (Fig 3.1.3.1b). It therefore seems likely that this G insertion is due to a sequence read error, especially given that that it occurred immediately after another G strongly indicating that the automatic base calling software read one peak as two, and that this was not corrected by the author. Eight bases downstream of this insertion in the GenBank sequence (U61318.1) there is a deletion of T. It therefore seems likely this is also another error, possibly due to a slight misalignment in the base-calling program used. This miscalling can frequently occur, especially a misread of one large peak as two followed by the skipping of a later peak (pers. Obs.). Manual checking of all base calls on all sequences were made in this project to alleviate this risk (as well as checks for degenerate bases). Other differences between the GenBank sequence and collected sequence occur toward the end of the amplified fragment, these are substitutions rather than insertions and deletions so are more likely to be accurate. In both the *MATK* from collected *Phyllodoce caerulea* and the Genbank sample there are sections that differ from one another but match other *MATK* sequences (Fig. 3.1.3.1). Given that *MATK* sequences from plants from different locations can vary (see *Calluna vulgaris* *MATK* above) it is

possible that the Genbank sequence comes from a plant from a different location than the collected sample (Norway). Unfortunately this is unknown, as the Genbank sample was collected from a cultivated plant at the RBG Edinburgh (Kron, 1997) however no origin data on the plant exists (RBG Edinburgh, 2018a).

The 100 % identity between *Cassiope tetragona* from Abisko, Sweden, and the Genbank sequence (KC474423.1), from Canada (Fig. 3.1.3.1) indicates that these two populations have not greatly diverged.

The 100 % identity between all *Empetrum nigrum* sequences indicates very little divergence between these populations (Abisko, Canada and North America). Interestingly there is also 100 % identity with two plants identified as *Empetrum hermaphroditum* (now typically not recognised as a second species but as the subspecies *Empetrum nigrum* subsp. *hermaphroditum*). It is notoriously difficult to distinguish between the two subspecies (and the method of identification is also debated) (see section: 5.2.6) so it is possible that these two specimens have been mis-identified (note: no attempt was made to distinguish between the two subspecies in samples collected in this project, see: section 5.2.6 for justification). Alternatively, these results might indicate that these are not separate subspecies, showing greater similarity to one another than different populations of the same species (*Calluna vulgaris*) do to one another (Fig. 3.1.3.1). For further discussion on *Empetrum nigrum* subspecies please see: Section 5.2.6.

Chapter 4: Introducing Mutations into *Arabidopsis thaliana* CBF1 that Represent Common Polymorphisms Seen in Arctic and Alpine Plants and Testing for Effect upon Function

Aims and Objectives

The aim of this chapter was to test the polymorphisms identified in Chapter 3 to assess if they alter freezing tolerance. The main objectives were, therefore: to establish stable overexpressing transformed *Arabidopsis thaliana* lines with a range of levels of expression for each synthetic gene; to test the ability of these synthetic genes to induce *COR* gene expression; to assess the viability of the transient plasmid system provided by Nassuth et al., 2014 as a tool to compare the ability of these synthetic genes to bind and activate the CRT promoter motif.

Hypotheses:

9. The polymorphisms identified in Chapter 3 will alter the binding and/or activity of CBF when introduced into *Arabidopsis thaliana* CBF1.
10. The polymorphisms identified in Chapter 3 will alter the degree of *COR* gene expression, relative to wildtype *Arabidopsis thaliana* CBF1, when introduced into *Arabidopsis thaliana* CBF1 and stably transformed into *Arabidopsis thaliana*.
11. The polymorphisms identified in Chapter 3 infer greater freezing tolerance, relative to wildtype *Arabidopsis thaliana* CBF1, when introduced to *Arabidopsis thaliana* CBF1 and stably transformed into *Arabidopsis thaliana*.

4.1 Results

4.1.1 Transient Expression of *CBF1* Mutations in *Nicotiana benthamiana*

Synthetic *Arabidopsis CBF1* genes containing amino acid mutations based upon differences seen in wild plants (Table. 2.5.2.1 and section 3.2.1.4) were transiently expressed in *Nicotiana benthamiana* alongside reporter plasmids containing a CRT/DRE element (see Fig. 2.8.7.1 and methods section 2.8.10)

Results across all infiltration events were amalgamated, via further normalisation by setting the wildtype overexpressor for each experiment as 1 and expressing the other constructs as fold changes in CRT expression relative to wildtype (Fig. 4.1.1.1). This indicated very little difference in activation of CRT by the altered *CBF* genes DSAWQ, DSLWR, DSVWQ and DSVWR relative to *CBF1* wildtype overexpressor. The only *CBF* to demonstrate a change in CRT activation was the PKK synthetic gene which caused a decrease in CRT activation to an average of 0.24X that of the wildtype (Fig. 4.1.1.1).

There was a large variance in normalised photon count (indicating the degree of CRT activation – see section 2.8.10) across different infiltration experiments varying from 0.09 (Fig. 4.1.1.4) to 16.3 (Fig. 4.1.1.3) for wildtype *CBF* overexpressor. The other synthetic genes showed a similar variance with photon counts for individual experiments of the same order of magnitude as the corresponding wild type *CBF* overexpressor.

Different patterns were seen across different experiments. In the initial experiment (Fig. 4.1.1.2) DSAWQ showed a 2.0 fold increase in activation of CRT relative to wildtype (6.9 vs 3.5) with no overlap in standard error bars. DSVWQ and DSVWR also showed a possible 1.6 and 2.0 fold increase respectively compared to the *CBF* wildtype

overexpressor (5.5 and 6.9 vs 3.5) however standard error bars overlap those of the wild type overexpressor. DSLWR showed a decrease in activation to 0.085X that of the wild type overexpressor (0.3 vs 3.5) with clearly separated standard error bars.

In contrast to the increase seen in Fig. 4.1.1.2 in Fig 4.1.1.3 DSAWQ, DSVWQ and DSVWR all showed a decrease in CRT activation to 0.32X, 0.42X and 0.26X that of the *CBF* wild type overexpressor (5.2, 6.9 and 4.3 vs 16.3 respectively) with no overlap of error bars (Fig. 4.1.1.3). PKK also showed a decrease to 0.036X that of the *CBF* wild type overexpressor (0.05 vs 1.4) with no overlap of error bars which is consistent with results seen in Fig. 4.1.1.2. DSLWR also showed a possible 2.6X increase (3.6 vs 1.4) in contrast to Fig. 4.1.1.2 however the error bars overlapped (Fig. 4.1.1.3).

Again, a different pattern was seen in the third experiment (Fig. 4.1.1.4) very little difference was seen between DSAWQ and the wildtype overexpressor (0.09 vs 0.087) (Fig. 4.1.1.4). DSVWQ, DSVWR in concordance with (Fig. 4.1.1.3) but in contrast to (Fig. 4.1.1.2) showed a potential decrease in CRT activation to 0.86X and 0.78X that of the *CBF* wild type overexpressor (0.075, 0.068 vs 0.087 respectively) however all error bars overlap (Fig. 4.1.1.4). DSLWR also showed a decrease relative to the wild type overexpressor to 0.61X that of the wildtype (0.053 vs 0.087) in concordance with (Fig. 4.1.1.2) but in contrast to (Fig. 4.1.1.3) with no overlap of error bars (Fig. 4.1.1.4). PKK was consistent with (Fig. 4.1.1.2 and 4.1.1.3) and showed a decrease 0.55X that of the *CBF* wild type overexpressor (0.048 vs 0.087) with no overlap of error bars (Fig. 4.1.1.4).

The only *CBF* construct to show consistent activation behaviour across all experiments (Fig. 4.1.1.2, 4.1.1.3, 4.1.1.4) was PKK which consistently displayed a decrease relative to *CBF* wildtype with no overlap in error bars which is reflected in the amalgamated data (Fig 4.1.1.1).

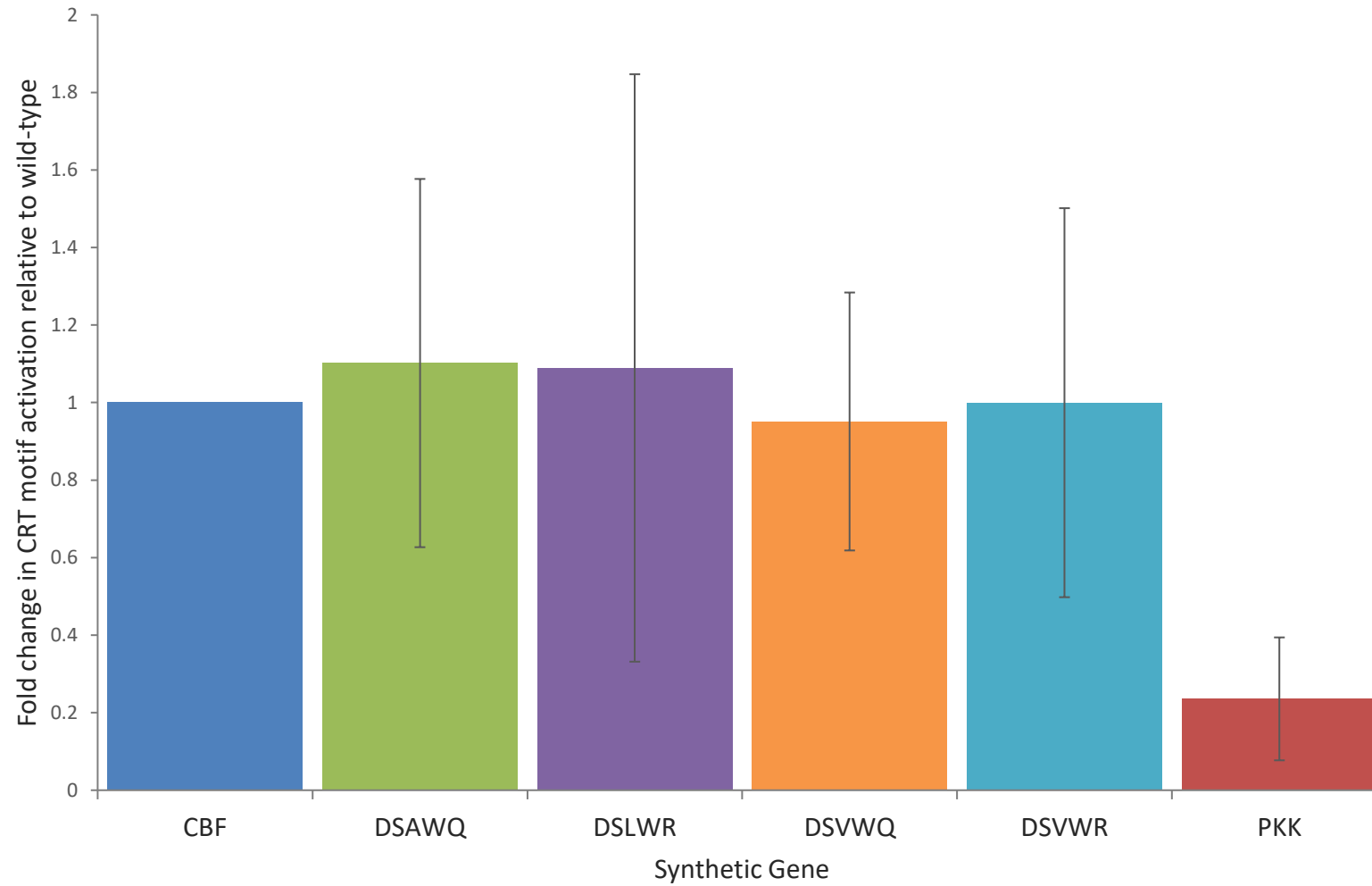

Figure 5.1.1.1. Data from multiple transient expression experiments (see section 2.8.10), depicting fold increase in activation of CRT by various synthetic genes (Table 2.5.2.1) relative to *A. thaliana* wild type *CBF1* (*CBF* normalised to 1). Error bars denote standard error from the mean (n=3).

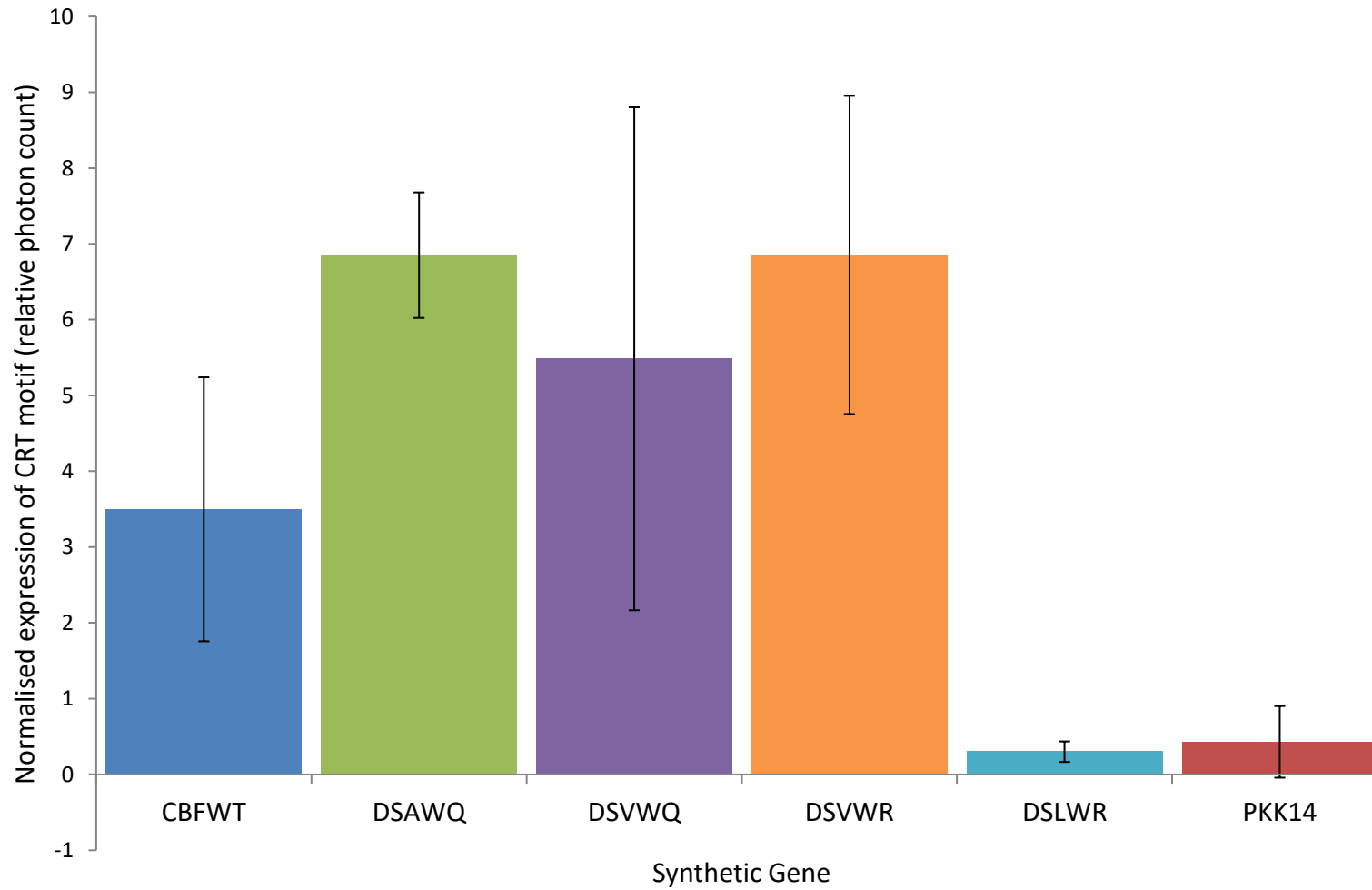

Figure 4.1.1.2. Data from a transient expression experiment (see section 2.8.10). Bars represent mean normalised photon count (see section 2.8.10 for explanation of normalisation) from the activation of CRT by various synthetic *CBF* genes (Table 2.5.2.1). Error bars denote standard error from the mean ($n=3$).

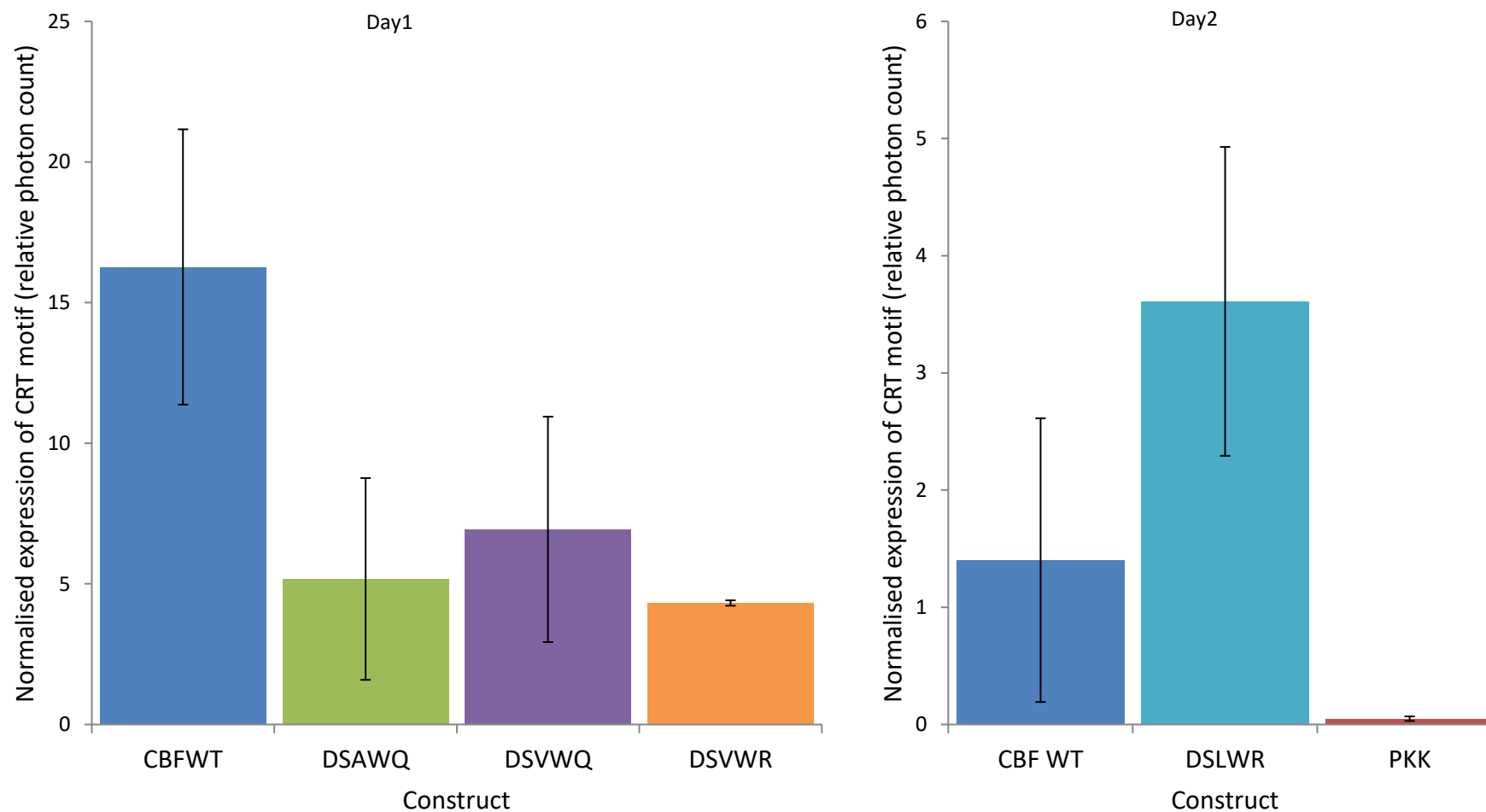

Figure 4.1.1.3. Data from a transient expression experiment (see section 2.8.10) performed across two consecutive days. Bars represent mean normalised photon count (see section 2.8.10 for explanation of normalisation) from the activation of CRT by various synthetic *CBF* genes (Table 2.5.2.1). Error bars denote standard error from the mean (n=3).

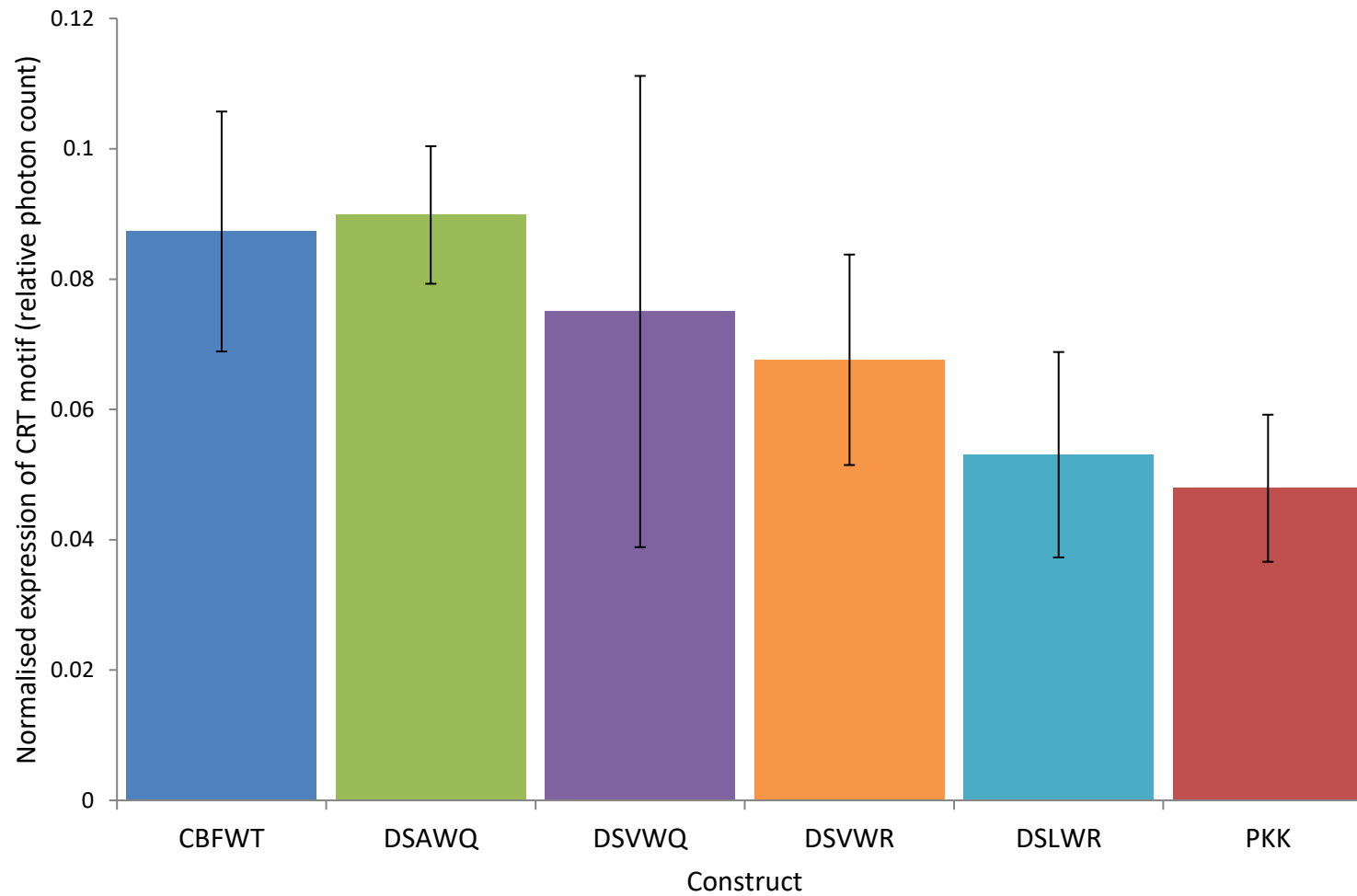

Figure 4.1.1.4. Data from a transient expression experiment (see section 2.8.10). Bars represent mean normalised photon count (see section 2.8.10 for explanation of normalisation) from the activation of CRT by various synthetic *CBF* genes (Table 2.5.2.1). Error bars denote standard error from the mean ($n=3$).

4.1.2 Overexpression of *CBF1* Constructs in *Arabidopsis thaliana*

4.1.2.1 Establishment of Stable Transgenic *Arabidopsis thaliana* lines

Survival of transformant plants was low with approximately 56 % of all transformed seedlings dying before seed-set (Table 4.1.2.1.1). PKK transformants showed the highest death rate with only three viable seedlings growing from dipped seed and of those three two died before seed-set (Table 4.1.2.1.1). DSAWQ was the most prolific line with 43 seedlings, 25 of which died and 18 survived through to set seed. DSLWR had the greatest survival rate with only 50 % of plants dying (Table 4.1.2.1.1). Of those that survived to set seed, the amount of seed produced was highly variable (Table 4.1.2.1.2). Samples with low seed volumes were not taken forward for freezing assays, saving seed for expression analyses.

Table 4.1.2.1.1 Number of plants germinated and grown from transformed seed (total number of lines), of these the number that survived to set seed (Number of surviving lines) and the number of lines that died before setting seed (Number of deceased lines). The percentage of plants that died prior to seed set is also shown.

Synthetic Gene	Synthetic Gene Code	Total Number of Lines	Number of Surviving Lines	Number of Deceased Lines	Percentage of Plants that Died
DSAWQ	114	43	18	25	58
DSLWR	122	12	6	6	50
DSVWR	126	13	6	7	54
WT	106	30	13	17	57
DSVWQ	118	18	8	10	56
PKK	110	3	1	2	67
Total		119	52	67	56

Table 4.1.2.1.2. Series of tables indicating approximate volume of seed harvested from each independent transgenic plant (the progenitor of a seed line). Tables separated by synthetic gene (see section 2.5.2 for full details on synthetic genes). Volumes $\leq 30\mu\text{l}$ are highlighted in red.

DSAWQ			DSLWR			DSVWR			WT		
~Volume of Seed (μl)	Gene Code	Line	~Volume of Seed (μl)	Gene Code	Line	~Volume of Seed (μl)	Gene Code	Line	~Volume of Seed (μl)	Gene Code	Line
5	114	5	50	122	1	40	126	1	200	106	4
300	114	7	5	122	3	200	126	4	30	106	7
100	114	8	180	122	4	100	126	5	100	106	8
5	114	14	50	122	7	200	126	8	150	106	9
100	114	15	100	122	11	250	126	9	0.5	106	10
200	114	17	100	122	12	150	126	10	80	106	12
150	114	19							40	106	14
100	114	20							250	106	16
250	114	22							5	106	19
250	114	23							70	106	21
100	114	24							40	106	22
150	114	25							250	106	23
400	114	26							0.5	106	25
3	114	28									
200	114	31									
300	114	32									
300	114	34									
5	114	35									

DSVWQ			PKK		
~Volume of Seed (μl)	Gene Code	Line	~Volume of Seed (μl)	Gene Code	Line
5	118	2	125	110	3
125	118	4			
500	118	5			
200	118	8			
90	118	13			
85	118	14			
125	118	16			
300	118	18			

4.1.2.2 Expression of *CBF1* and *COR* Genes in Transgenic *Arabidopsis thaliana* Lines

Fold increase in expression levels of the two different *COR* genes (*KIN2* and *LTI78*) relative to the fold increase of *CBF* expression was, overall, highly consistent within individual plant lines when comparing between the two *COR* genes *KIN2* (Fig. 4.1.2.2.1) and *LTI78* (Fig. 4.1.2.2.2). One exception was the extremely high expressing DSAWQ line (2057 fold increase in *CBF* expression) which had a 45 fold increase in *KIN2* expression (Fig. 4.1.2.2.1) which increased to a 110 fold increase in *LTI78* expression (Fig. 4.1.2.2.2). This resulted in this line having the highest expression of *LTI78* of all plants studied: whereas it was the 5th highest expresser of *KIN2*.

At high levels of *COR* gene expression (>7X) there was very little evidence of a pattern that might suggest one synthetic gene line expresses *COR* genes to a higher level relative to *CBF* expression than any other (Fig. 4.1.2.2.1 and Fig. 4.1.2.2.2). There was some slight indication that the overexpressor of the native wild-type *CBF1* may express *COR* genes to a greater level for a given increase in *CBF* expression however this was minimal (Fig. 4.1.2.2.1 and 4.1.2.2.2). There was no evidence of a linear relationship between increasing *CBF* expression and *COR* gene expression for any synthetic gene.

At low levels of *COR* gene expression <7X (see zoomed in sections of Fig. 4.1.2.2.1 and 4.1.2.2.2) there was a similar apparent random distribution between different synthetic genes. DSVWQ possibly showed a slight trend of lower *COR* gene expression relative to *CBF* expression level.

There were three examples of very low fold increase in *COR* gene expression associated with a high increase in *CBF* expression; DSVWQ 6x vs 85x, DSVWR 3x vs 96x and DSAWQ 3x vs 310x (Fig. 4.1.2.2.1 and 4.1.2.2.2).

There were several plant lines which show a fold decrease in *CBF* expression relative to the non-overexpressing wild-type plants but an increase in *COR* gene expression. Some lines from all synthetic genes exhibited this, with the exception of PKK. However, it should be noted there was only one line expressing this gene. Further, the DSVWQ lines and DSVWR lines show *COR* gene expression close to 1 (Fig. 4.1.2.2.1 and Fig. 4.1.2.2.2).

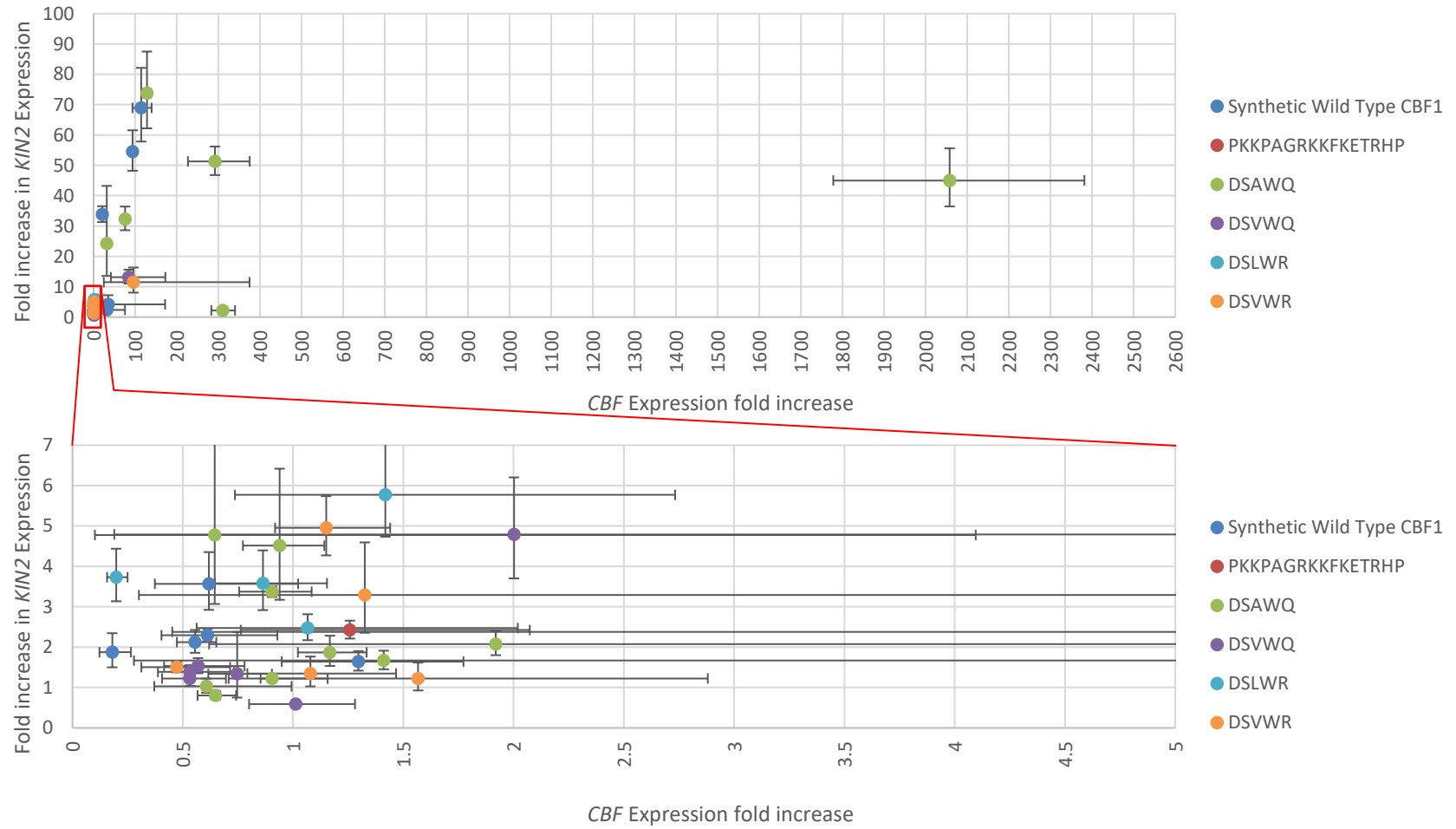

Figure 4.1.2.2.1. Points indicate fold increase in *CBF* expression relative to wildtype (see section 2.7.5 for details) vs fold increase in *COR* gene *KIN2* expression relative to wildtype. Each sample consists of RNA extracted from multiple seedlings of the same genotype. Error bars denote standard error of the mean (n=3 technical repeats)

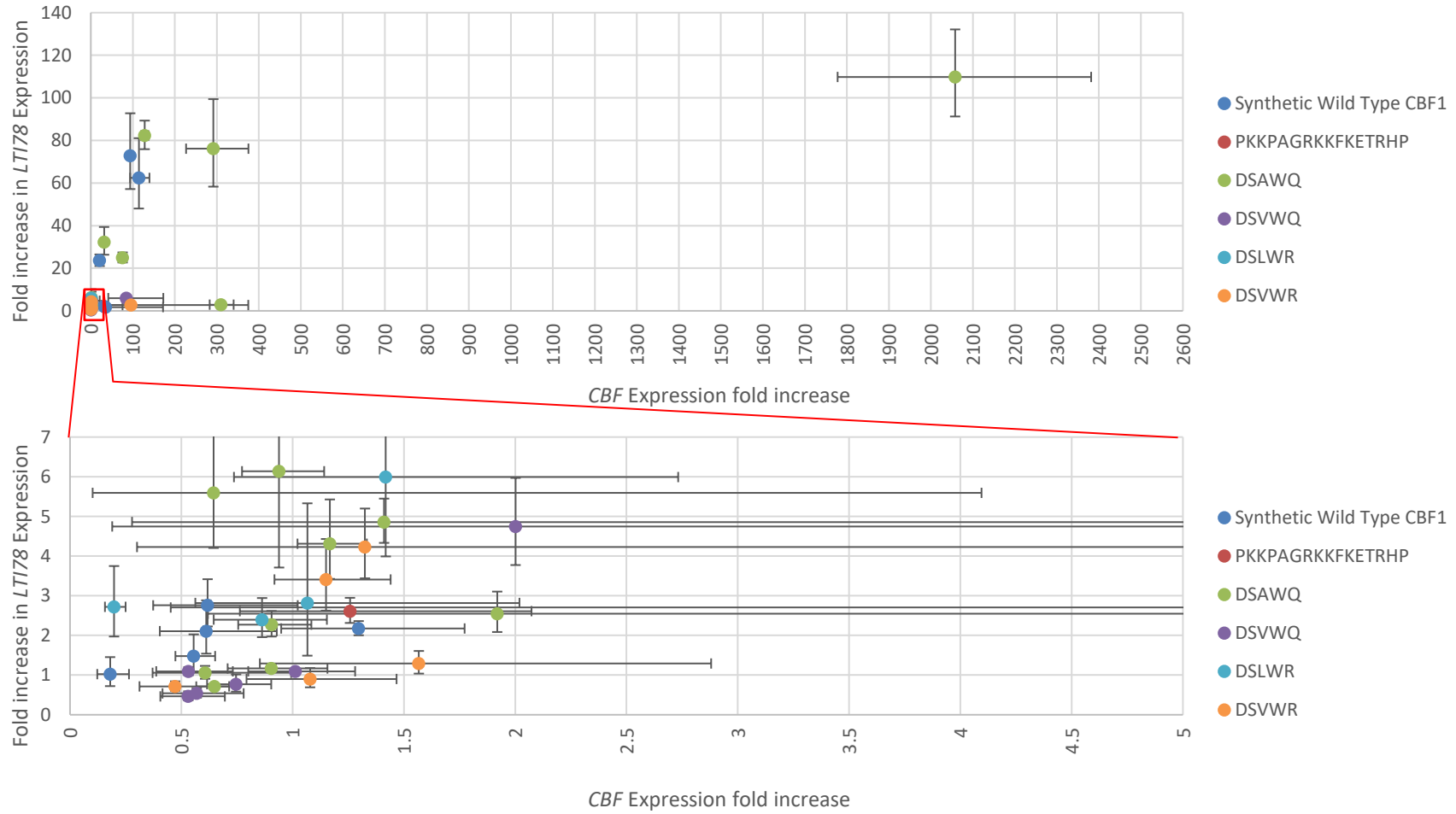

Figure 4.1.2.2.2. Points indicate fold increase in *CBF* expression relative to wildtype (see section 2.7.5 for details) vs fold increase in *COR* gene *LTI78* expression relative to wildtype. Each sample consists of RNA extracted from multiple seedlings of the same genotype. Error bars denote standard error of the mean (n=3 technical repeats)

4.1.2.3 Ability of Different *CBF1* Constructs to Activate *COR* Genes in Transgenic *Arabidopsis thaliana*

On average DSLWR had a greater fold increase in expression of *KIN2* and *LTI78* relative to *CBF* expression (indicating a greater activation ability) than all other synthetic genes (Fig. 4.1.2.3.1). For *KIN2* the error bars of DSLWR overlapped those of the wildtype *CBF1* overexpressor (Fig. 4.1.2.3.1) however for *LTI78* the error bars did not overlap with any other synthetic gene (Fig. 4.1.2.3.1). The other synthetic genes all had a similar degree of activation ability with overlapping error bars (Fig. 4.1.2.3.1).

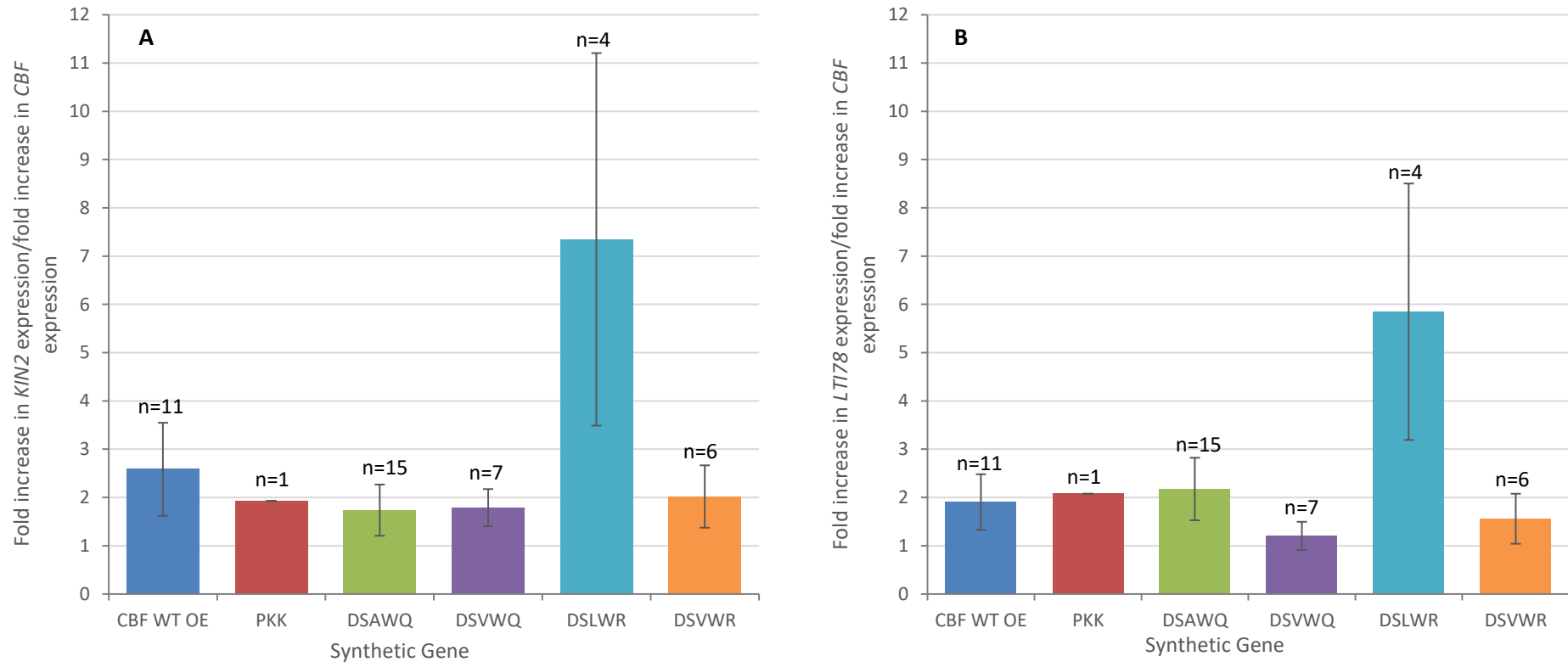

Figure 4.1.2.3.1. Activation ability of various overexpressed *CBF* synthetic genes (see section 2.5.2) expressed as fold increase in *COR* gene (A) *KIN2* and (B) *LTI78* expression relative to wild-type/fold increase in *CBF* expression relative to wild-type. Error bars denote standard error of the mean, n=X above bars indicates number of independent transgenic plant lines successfully generated for that synthetic gene contributing qPCR data used for calculation of the mean.

4.1.2.4 Ability of Transgenic *Arabidopsis thaliana* to Survive Freezing in Relation to the Degree of *CBF1* and *COR* Gene Expression

When subjected to a sudden freezing shock of -7 °C for 24 h, the majority of plants died (Figs. 4.1.2.4.2, 4.1.2.4.3 & 4.1.2.4.4). However, several plants survived completely, whilst others showed partial survival. Those plants which had little to no negative response to the freezing shock had a compact dwarf phenotype. All plants with this phenotype survived (Figs. 4.1.2.4.2, 4.1.2.4.3 & 4.1.2.4.4). Whilst there were some small plants, such as a couple of examples of Wild-type CBF 1 overexpressor Line 7 (“u” top row Fig 4.1.2.4.3a B&D and middle row 4.1.2.4.4a A&C) that did not survive, they did not show the compactness associated with the phenotype of the dwarf surviving plants (for example as seen with plant DSAWQ line25 (“n” Fig. 4.1.2.4.2c A&B)).

Those plants which survived were;

- Line DSAWQ 125 (n) where 2/5 plants demonstrated dwarfism and complete freezing survival (Fig 4.1.2.4.2b A,C top row and Fig. 4.1.2.4.2c A,B bottom row)
- Line *CBF* WT L21 (k) where 1/6 plants demonstrated high survival with partial dwarfism (Fig. 4.1.2.4.2b B,D bottom row)
- Line DSAWQ L24 (£) where 4/12 plants demonstrated dwarfism with high survival (Fig. 4.1.2.4.3b B,D central row, Fig. 4.1.2.4.4a B,D central row, Fig. 4.1.2.4.4b A,C top row and Fig. 4.1.2.4.4c A,B bottom row. A further plant showed no dwarfism and very little survival, with only the central meristem showing green Fig. 4.1.2.4.3c.
- Line DSAWQ L20 (x) where 2/12 plants demonstrated partial freezing survival. One plant had some green still visible in the central meristem (Fig. 4.1.2.4.4a B,D) and the other showed more green tissue in the central meristem (Fig. 4.1.2.4.4b A, C bottom row).

- Line DSAWQ (t) L23 where 1/12 plants demonstrated partial freezing survival with green tissue still seen in the central meristem (Fig. 4.1.2.4.4b B,D top row).

Those plant lines containing individuals which demonstrated full survival and dwarfism (DSAWQ L25, CBF WT L21 and DSAWQ L24) were also high expressers of both *CBF* and tested *COR* genes with a greater than 50 fold increase in *CBF* expression and greater than 20 fold increase in *COR* gene expression (Fig. 4.1.2.4.5 and Fig. 4.1.2.4.6). Two other plant lines, DSAWQ L15 and CBF WT L14 which also underwent visual freezing tests, also had a greater than 20-fold increase in both *COR* genes tested, however their *CBF* expression was lower than that of the survivors at 20X and 32X respectively (highlighted in yellow Fig. 4.1.2.4.5 and Fig. 4.1.2.4.6). These two lines demonstrated no freezing survival in the freezing assay tests (with 0/6 plants showing survival in both cases) and large healthy plants prior to freezing “e” and “j” (Fig. 4.1.2.4.2a-c)

The plants lines with some plants demonstrating partial survival, DSAWQ L20 and DSAWQ L23, had relatively low *CBF* and *COR* gene expression and were nested among numerous other plant lines which did not show any survival (Fig. 4.1.2.4.5 and Fig. 4.1.2.4.6)

The following observations were made when seeds were germinated for freezing assays. Numerous plates had variance in seedling size and this was especially evident in DSAWQ L24, which had a wide range of seedling size coupled with low germination. Examples from all sizes were taken to grow on for the freezing assays. CBF WT L7 had very low germination with extremely small plants and translucent cotyledons.

Table 4.1.2.4.1. Letters/symbols correspond to those of figures 4.1.2.4.2, 4.1.2.4.3 and 4.1.2.4.4. OE Gene is the synthetic *CBF1* gene that the plant line has been transformed to overexpress (Table 2.5.2.1). No OE denotes that the plant has not been transformed i.e. is untransformed wildtype *Arabidopsis thaliana*. Line indicates the code given to each independent transgenic line and therefore which transgenic line corresponds with which letter/symbol from figures 4.1.2.4.2, 4.1.2.4.3 and 4.1.2.4.4.

Code	OE Gene	Line
a	DSAWQ	134
b	DSVWQ	114
c	DSVWQ	113
d	DSVWR	14
e	DSAWQ	115
f	PKK	134
g	DSLWR	111
h	no OE	Wildtype
i	CBF1 WT	116
j	CBF1 WT	114
k	CBF1 WT	121
l	DSVWR	15
m	DSLWR	14
n	DSAWQ	125
o	DSLWR	L7
p	DSAWQ	L32
q	DSAWQ	L31
r	DSAWQ	L8
s	DSAWQ	L22
t	DSAWQ	L23
u	CBF1 WT	L7
v	DSLWR	L1
w	DSVWR	L1
x	DSAWQ	L20
y	CBF1 WT	L12
z	no OE	Wildtype
£	DSAWQ	L24



Figure 4.1.2.4.2a. T1 generation of *Arabidopsis thaliana* plants transformed to constitutively overexpress synthetic *CBF1* lines (Table 2.5.2.1) (a-g, i-n) and wildtype *A. thaliana* plants (h). Before (A, B) and 3 days after (C, D) being subjected to a -7°C freezing shock (section 2.3.2). Letters correspond to the plant line studied (table 4.1.2.4.1).

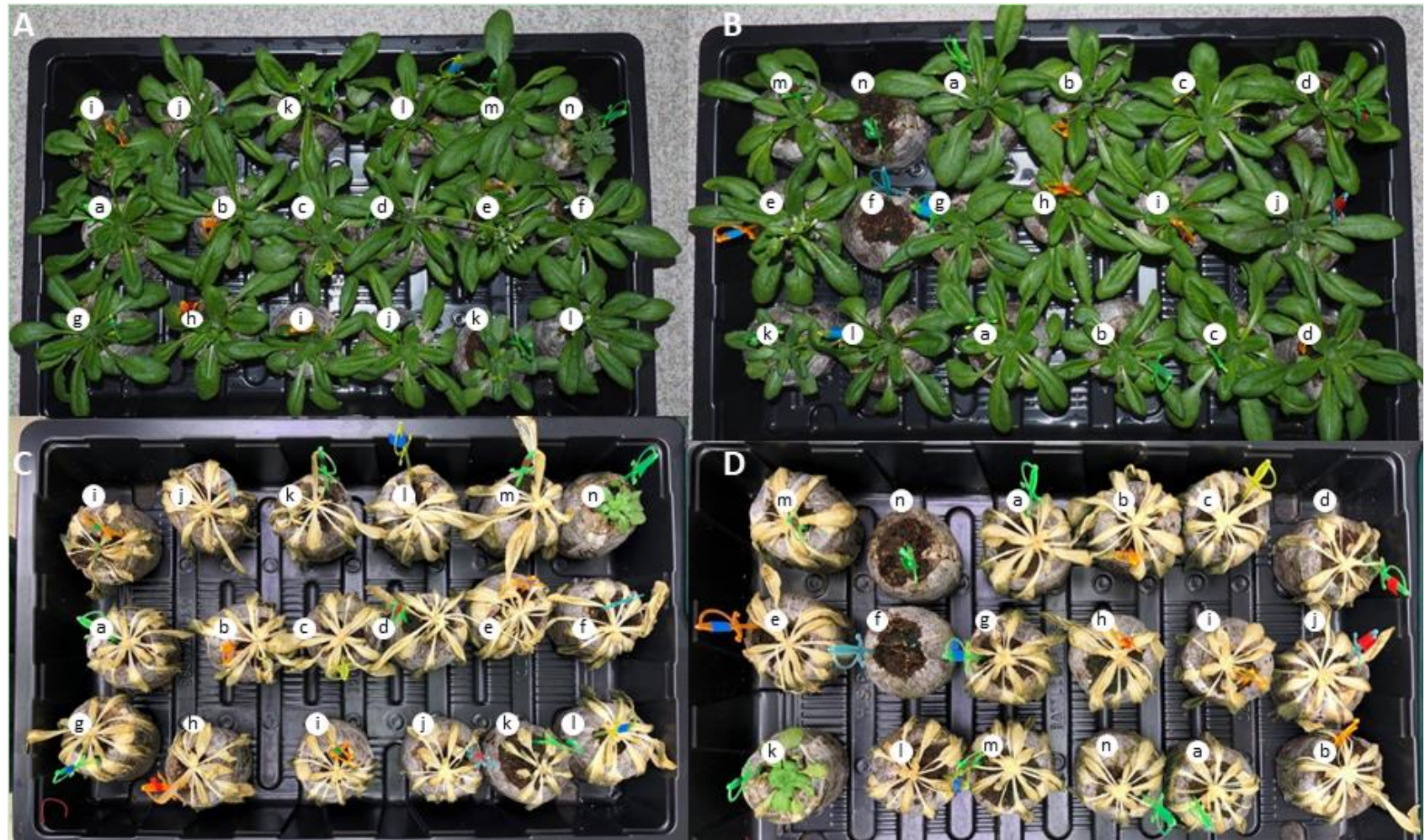

Figure 4.1.2.4.2b. T1 generation of *Arabidopsis thaliana* plants transformed to constitutively overexpress synthetic *CBF1* lines (Table 2.5.2.1) (a-g, i-n) and wildtype *A. thaliana* plants (h) Before (A, B) and 3 days after (C, D) being subjected to a -7°C freezing shock (section 2.3.2). Letters correspond to the plant line studied (table 4.1.2.4.1).



Figure 4.1.2.4.2c. T1 generation of *Arabidopsis thaliana* plants transformed to constitutively overexpress synthetic *CBF1* lines (Table 2.5.2.1) (c-g, i-n) and wildtype *A. thaliana* plants (h) Before (A) and 3 days after (B) being subjected to a -7°C freezing shock (section 2.3.2). Letters correspond to the plant line studied (table 4.1.2.4.1).



Figure 4.1.2.4.3a. T1 generation of *Arabidopsis thaliana* plants transformed to constitutively overexpress synthetic *CBF1* lines (Table 2.5.2.1) (o-y, £) and wildtype *A. thaliana* plants (z) Before (A, B) and 3 days after (C, D) being subjected to a -7°C freezing shock (section 2.3.2). Letters correspond to the plant line studied (table 4.1.2.4.1).



Figure 4.1.2.4.3b. T1 generation of *Arabidopsis thaliana* plants transformed to constitutively overexpress synthetic *CBF1* lines (Table 2.5.2.1) (o-y, £) and wildtype *A. thaliana* plants (z) Before (A, B) and 3 days after (C, D) being subjected to a -7°C freezing shock (section 2.3.2). Letters correspond to the plant line studied (table 4.1.2.4.1).



Figure 4.1.2.4.3c. T1 generation of *Arabidopsis thaliana* plants transformed to constitutively overexpress synthetic *CBF1* lines (Table 2.5.2.1) (y, ε) and wildtype *A. thaliana* plants (z) Before (A) and 3 days after (B) being subjected to a -7°C freezing shock (section 2.3.2). Letters correspond to the plant line studied (table 4.1.2.4.1).



Figure 4.1.2.4.4a. T1 generation of *Arabidopsis thaliana* plants transformed to constitutively overexpress synthetic *CBF1* lines (Table 2.5.2.1) (o-y, £) and wildtype *A. thaliana* plants (z) Before (A, B) and 3 days after (C, D) being subjected to a -7°C freezing shock (section 2.3.2). Letters correspond to the plant line studied (table 4.1.2.4.1).

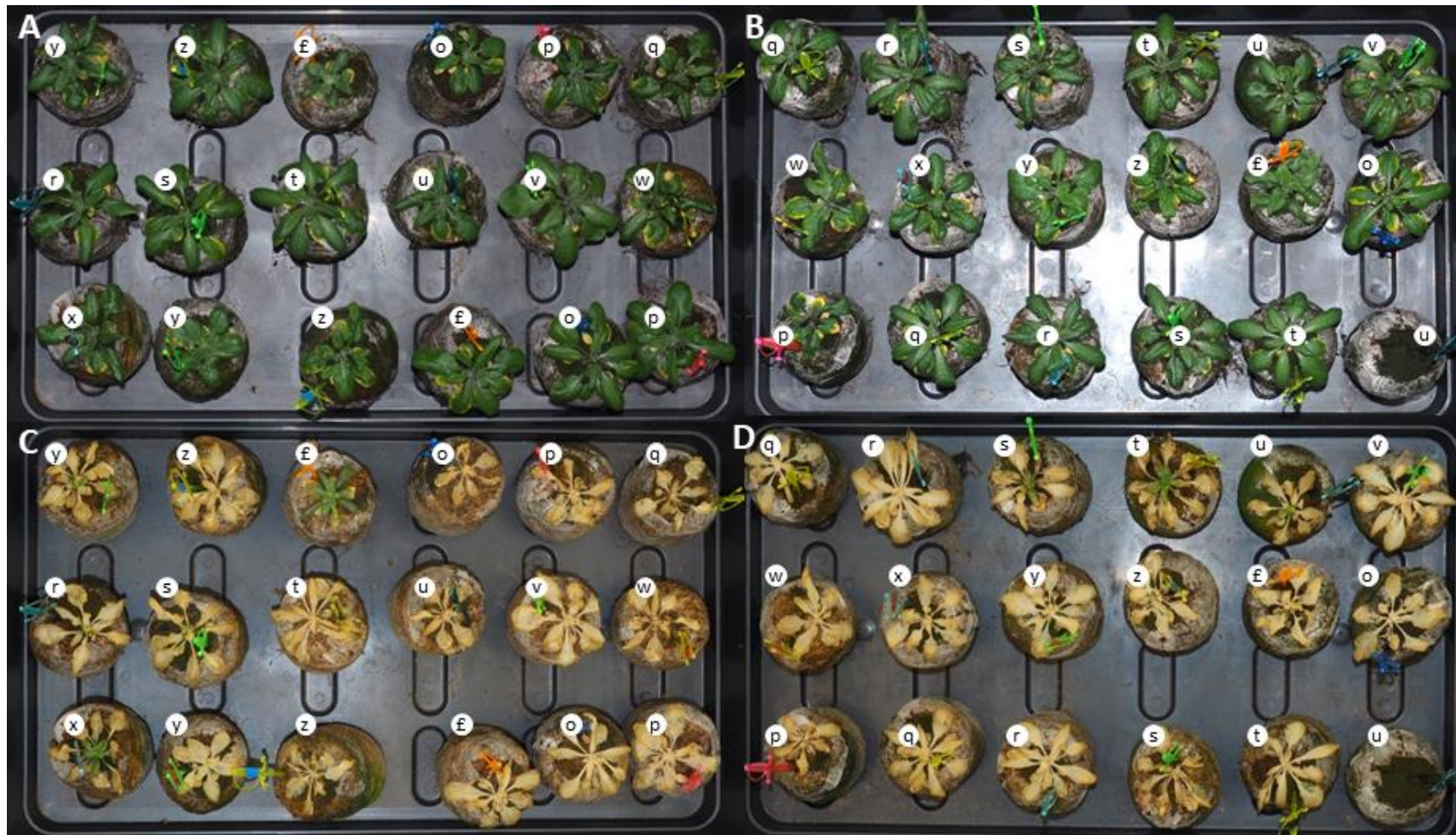

Figure 4.1.2.4.4b. T1 generation of *Arabidopsis thaliana* plants transformed to constitutively overexpress synthetic *CBF1* lines (Table 2.5.2.1) (o-y, £) and wildtype *A. thaliana* plants (z) Before (A, B) and 3 days after (C, D) being subjected to a -7°C freezing shock (section 2.3.2). Letters correspond to the plant line studied (table 4.1.2.4.1).



Figure 4.1.2.4.4c. T1 generation of *Arabidopsis thaliana* plants transformed to constitutively overexpress synthetic *CBF1* lines (Table 2.5.2.1) (v-y, £) and wildtype *A. thaliana* plants (z) Before (A) and 3 days after (B) being subjected to a -7°C freezing shock (section 2.3.2). Letters correspond to the plant line studied (table 4.1.2.4.1).

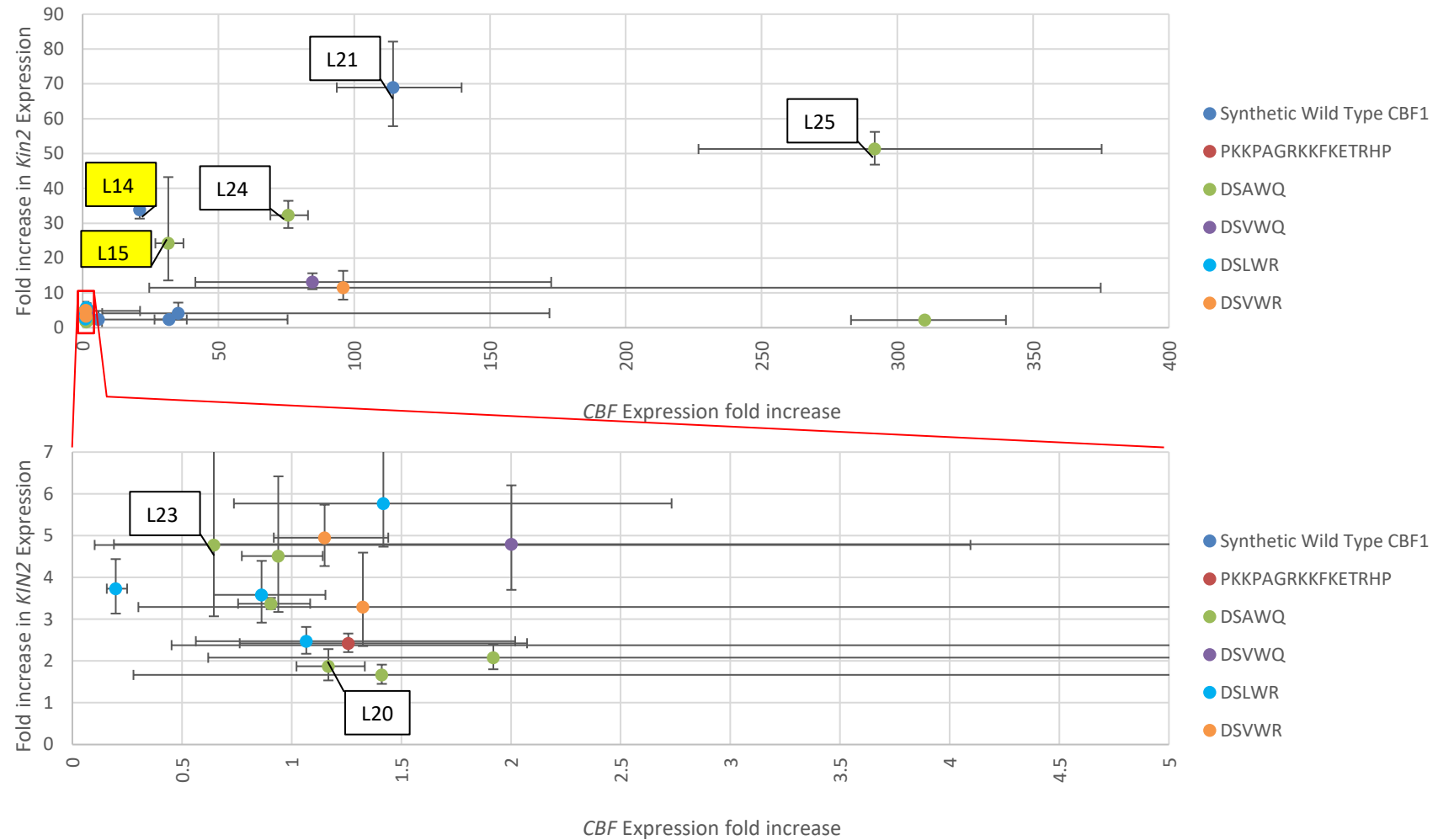

Figure 4.1.2.4.5. figure 4.1.2.2.1 depicting only those results from plants which were successfully grown for visual freezing assays. Plants which showed full or partial survival from freezing (see section 4.1.2.4) are labelled with their line name. Two other points of interest; those which did not show any survival in response to freezing are labelled with their line name and highlighted in yellow. Points indicate fold increase in *CBF* expression relative to wildtype (see section 2.7.5 for details) vs fold increase in *KIN2* expression relative to wildtype, each sample consists of RNA from multiple seedlings of the same genotype. Error bars denote standard error of the mean (n=3 technical repeats).

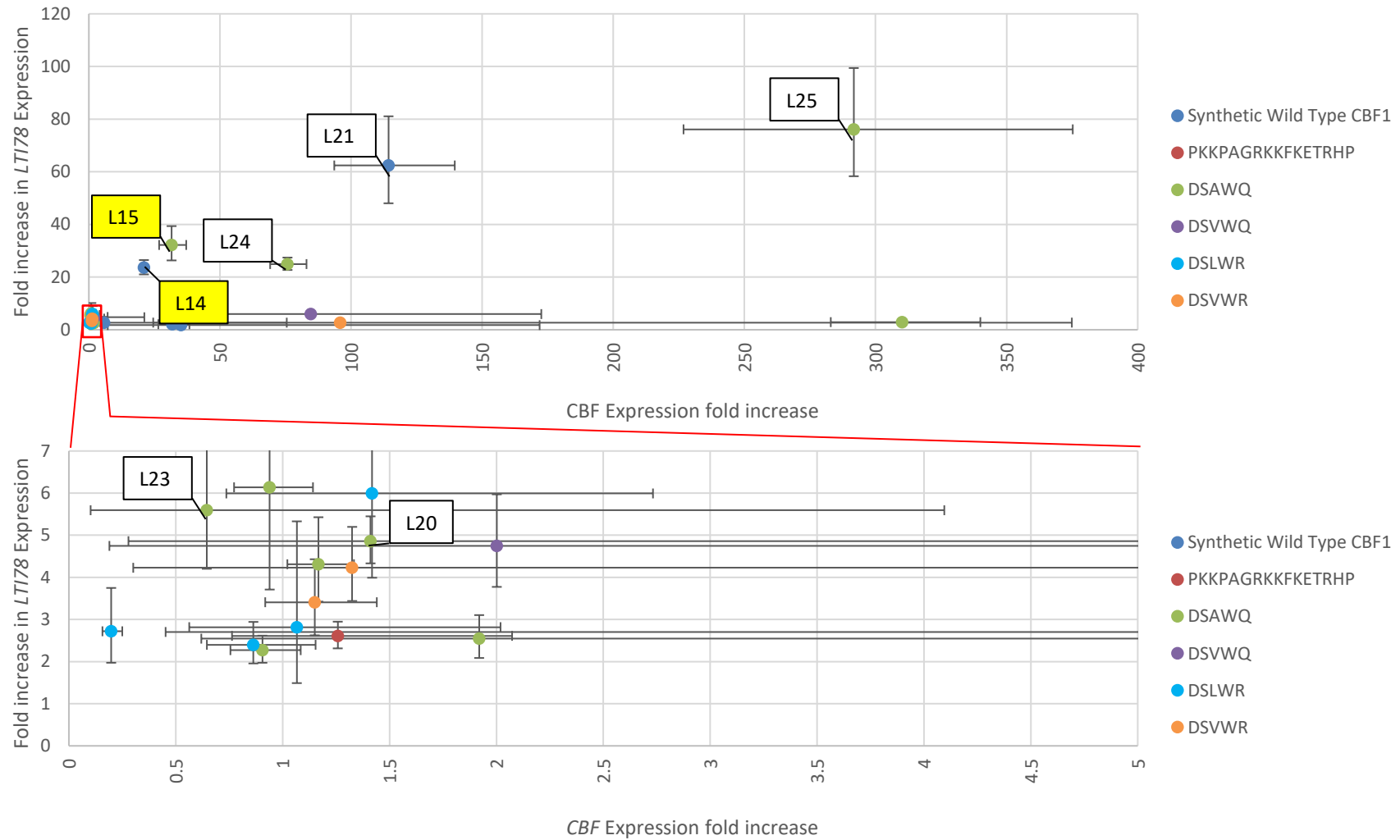

Figure 4.1.2.4.6. figure 4.1.2.2.2 depicting only results from plants which were successfully grown on for visual freezing assays. Plants which showed full or partial survival from freezing (see section 4.1.2.4) are labelled with their line code. Two other points of interest; those which did not show any survival in response to freezing are labelled with their line name and highlighted in yellow. Points indicate fold increase in CBF expression relative to wildtype (see section 2.7.5 for details) vs fold increase in *LTI78* relative to wildtype, each sample consists of RNA from multiple seedlings of the same genotype. Error bars denote standard error of the mean (n=3 technical repeats).

4.2 Discussion

4.2.1 Effect of *CBF1* Mutations Upon CRT/DRE Activation when Transiently Expressed in *Nicotiana benthamiana*

(See section 3.2.1.4 for discussion of the mutations performed in *CBF1* and their likely significance).

The only synthetic CBF to activate the CRT/DRE element with a consistent difference in expression level relative to wild-type was PKK (Table 2.5.2.1). This is reflected in the amalgamated data in being the only synthetic gene to show a difference from wildtype with no overlap of error bars (Fig. 4.1.1.1). The PKK substitution (R(11) to K) had greatly reduced activation of the CRT gene relative to wildtype (Fig. 4.1.1.1). Interestingly a previously unconserved (positively charged to neutral) substitution of this amino acid (R to S) had been shown to cause no significant effect upon CBF's ability to bind the CRT element (Canella et al., 2010), whereas R to K was highly conserved; both polar, positively charged and hydrophilic with a similar structure. Two possibilities for this reduced activation exist: either the R to K substitution greatly hinders binding to the CRT element, or it results in strong binding which is deleterious to the plant. It seems unlikely that the R to K substitution hinders binding, given that an un-conserved substitution does not affect binding (Canella et al., 2010). It has also been shown that *Vaccinium myrtillus* CBF (a sequence including the R to K substitution) is able to activate *COR* genes in *Arabidopsis thaliana* and synthetic CRT reporters in *Nicotiana benthamiana* (the same species as used in these experiments) (Oakenfull et al., 2013). It is also unlikely that all species sequenced bar the Brassicaceae have a greatly reduced ability of CBF to bind and activate *COR* genes, especially given their cold origin environments. It therefore seems more likely that the PKK substitution is deleterious. This is supported by the stable

transformations of *Arabidopsis thaliana* where, after dipping, very few viable seeds were collected and of these successfully germinated individuals (three) only one individual survived to produce seed (Table. 4.1.2.1.1). Plants from this surviving line had a very low *CBF* expression (similar to that of wildtype) (Figs. 4.1.2.4.5 & 4.1.2.4.6). So, it is therefore possible that this remaining line is either an extremely low expressor (thereby limiting the potential deleterious effect) or not actually expressing the PKK synthetic gene at all. One possibility to explain the deleterious nature of the PKK substitution is that this conserved substitution is an extremely strong binder (as with the conserved F10 to Y substitution a performed by Canella et al, 2010). Although the CBF sequence of *Nicotiana benthamiana* is unknown, other members of the Solanaceae have the R(11) rather than K (uniport accession: Q8S9N5) as seen in members of the Brassicaceae (Fig. 3.1.2.2). Therefore, strong binding could result in a higher than usual activation of native *COR* genes leading to cell dormancy (in preparation for chilling and/or drought) or death from an extreme response. One possible example might be that a large increase in sugars, upregulated by CBF (Cook et al., 2004), could lead to cell toxicity or a high influx of water leading to cell rupture. High levels of activation of expression could also be activating native downregulators. 24 hours pass between infiltration and imaging so in this time expression of the CRT/DRE could be silenced. Alternatively, high levels of CBF protein, especially of those which have high affinity and bind strongly, could result in saturation and lead to non-specific binding to elements similar to the CRT/DRE (for example, other AP2 targets). This would result in the upregulation of numerous genes, some of which could be toxic to the cell in high concentrations or lead to the activation of programmed cell death, which other AP2 family transcription factors are involved in (Mase et al., 2013). It is known that various AP2 family members (of which CBF is itself a member) can bind to the binding elements of other members of the AP2 family with differing strengths (Agarwal et al., 2017). It is therefore possible that if the binding

strength and quantity of CBF protein is changed it may bind to other AP2 binding promoters outside of the usual CRT/DRE.

An alternative possible explanation is that of squelching: whereby an excess of transcription factor binds to regulators of transcription off of the DNA, they then sequester these regulators preventing DNA transcription (Ptashne, 1988, Simon et al., 2015). This sequestration would be more severe in strong, stable binders. It is known that mediator is involved in the activation of *COR* genes (Targets of CBF) in *Arabidopsis thaliana*, with mutants in certain mediator subunits being unable to activate *COR* genes (Hemsley et al., 2014). It has been postulated that CBF binds directly with these subunits (Hemsley et al., 2014) therefore, it is possible that, due to an excess of CBF, CBF is binding to the mediator complex external to the DRE/CRT motif. CBF is able to bind to the CRT/DRE without mediator (Hemsley et al., 2014), recruiting mediator which regulates transcription via polymerase II. However, if the excess CBF has tightly bound free mediator, activation of genes with the CRT/DRE promoter (even with CBF bound) will be downregulated due to the reduced ability to recruit the mediator complex. It is even possible that the PKK mutation is involved with the recruitment and binding of mediator, hence the stronger response. This would also explain the poor survival of stable line transformation of the PKK mutant, as mediator is involved in the regulation of activation of numerous genes (Hemsley et al., 2014, Mathur et al., 2011).

All DSAWR constructs (DSAWQ, DSVWQ, DSVWR, DSLWR) caused different expression levels relative to wildtype for different experiments but this resulted in no difference relative to wildtype when data from the three experiments was amalgamated (Fig. 4.1.1.1). At the lowest levels (Fig. 4.1.1.4), with a normalised photon count of 0.08 for wildtype, all error bars (bar those of DSLWR) overlapped those of wildtype however the general trend was toward a decrease in activation (apart from DSAWQ which showed no difference). At medium/low expression levels (normalised photon count of 1.4 for

wildtype) DSLWR had increased activation of the CRT/DRE, however error bars overlapped that of wildtype (the other DSAWR constructs were not tested against this wildtype example) (Fig. 4.1.1.3 day 2). At medium expression levels ((fig 4.1.1.2) normalised photon count of 3.5 for wildtype) all, bar DSLWR, showed an increase in CRT/DRE activation although only DSAWQ did so without overlap of error bars. DSLWR showed a decrease with no overlap of error bars. At the highest expression levels (Fig. 4.1.1.3 day 1) (normalised photon count of 16.2 for wildtype) all DSAWR constructs (bar DSLWR which was not tested) showed a decrease in CRT/DRE activation. The overall trend is therefore: at low expression levels all DSAWR constructs activate CRT/DRE to a lesser degree than, or the same as, wildtype. At medium expression levels the activation is greater than wildtype and at the highest expression levels activation is once again lower. This trend is inferred from only three points and with error bars overlapping in some cases. However, that all examples follow this trend to some extent increases the likelihood of a genuine trend. Further repeats with differing levels would have to be performed to assess if this is a true trend. The explanation for this trend could be that all constructs are more potent than wildtype at activating the DRE/CRT as exemplified at medium expression levels. The reduced activation at higher levels of expression relative to the wildtype overexpressor could be due to numerous factors as discussed with the PKK mutation namely: downregulation via native genes, squelching, non-specific binding or high expression of *COR* genes leading to dormancy or death due to stronger binding or activation activity of the construct *CBF* genes.

At lower expression levels, activation is also lower in the construct *CBF* genes than the wildtype overexpressor. It is possible that, if the construct *CBF*'s bind more strongly, they bind preferentially to the native CRT/DRE elements in *Nicotiana benthamiana* and do not disassociate as readily as the wildtype *CBF* therefore resulting in a reduced expression of the test gene. This is then overcome at medium expression levels resulting in higher

activation than the *CBF* wildtype overexpressor (Fig. 4.1.1.2 & 4.1.1.3). Assuming this pattern is not an artefact, DSLWR & DSAWQ are possibly the strongest binders or activators out of the DSAWR constructs (DSAWQ, DSVWQ, DSVWR, DSLWR), as this trend is shifted the furthest towards higher CRT/DRE activation at lower expression levels for these constructs (see Fig. 4.2.1.1 for conceptual diagram of trend shifts).

The transient expression experiments displayed a great deal of variability in results and large error bars that often overlapped (Fig. 4.1.1.2, 4.1.1.3 & 4.1.1.4), they were, therefore, deemed too variable for further exploration and thus stable lines were explored further instead. It would be interesting to perform *in vitro* studies upon the binding of these constructs to CRT/DRE elements, specifically electrophoretic mobility shift assays as exemplified by Canella et al., (2010). This could identify if the PKK substitution is capable of binding and if, as postulated, a strong binding effect is found. Similar tests could be performed upon all constructs. Other tests studying the health of transformed plants could also be performed such as chlorophyll fluorescence prior to and 24 h after introduction of the construct to identify the effect of the construct upon survival of the infiltrated leaves.

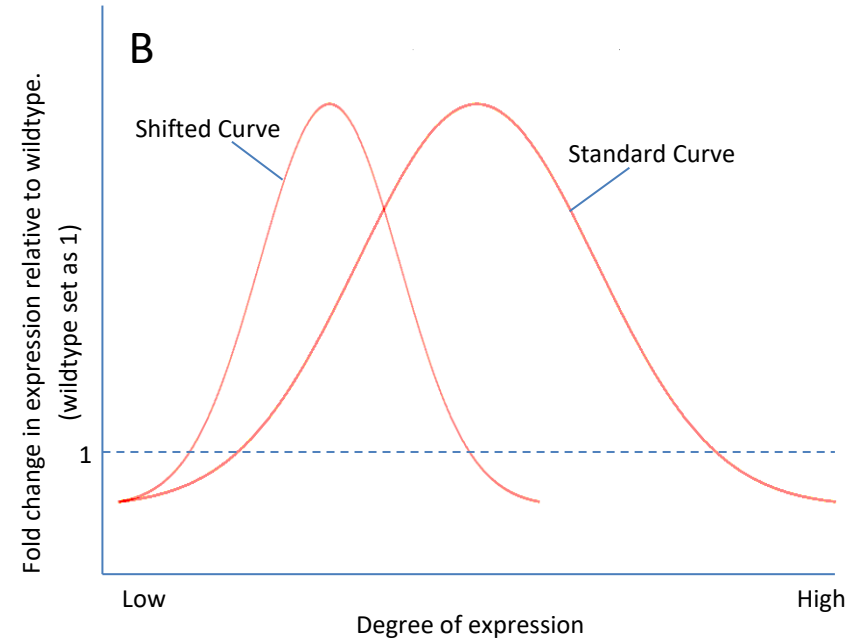
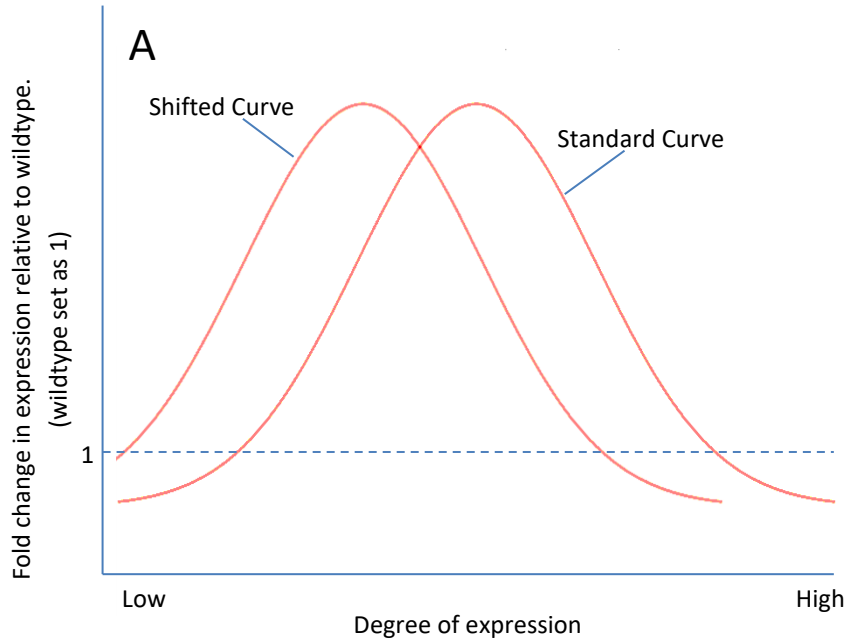

Figure 4.2.1.1. Conceptual diagram illustrating the two possible types of trend shift in fold change in *CBF* expression (relative to wildtype, set as 1) in A. DSAWQ, depicting a shift of curve to the left and B. DSLWR depicting a narrower spread resulting in earlier peak.

4.2.2 Effect of Stable Overexpression of *CBF1* Constructs in *Arabidopsis thaliana*

4.2.2.1 Establishment of Stable Transformed *Arabidopsis thaliana* Lines

Problems were encountered with the development of stable transformed lines. Multiple transformation events were undertaken. However, survival to seed set was poor, especially in plants transformed with the PKK construct. Of those seeds successfully collected germination rate was variable and especially poor in plants transformed with the PKK construct (Table 4.1.2.1.1). Survival of plants grown for bulking seed was also poor with an average of 56 % of plants dying before seed-set (Table 4.1.2.1.1). Possible explanations for poor survival and germination are discussed below.

Overexpression of *CBF1* (the gene used for the wild-type overexpressing control and basis for the synthetic genes) results in increased expression of *CBF1* target genes (Jaglo-Ottosen et al., 1998). One such target includes members the LEA protein family many of which have a CRT/DRE promoter element (Hundertmark and Hinch, 2008). Amongst other processes, members of this family are involved in is seed desiccation and maturation (Hundertmark and Hinch, 2008). It is therefore possible that overexpression of *CBF*, even at the flower bud infiltration stage, is causing premature seed maturation and desiccation resulting in infertile seeds and possibly bud termination leading to the observed low seed set.

CBF1 overexpression leads to an increase in expression of GA oxidase (Achard et al., 2008) which results in reduce accumulation of GA (Achard et al., 2008) which is involved in the breakdown of growth-repressing DELLA proteins (Achard et al., 2008). Among other activities, members of the DELLA protein subfamily repress germination (Tyler et

al., 2004). Therefore, *CBF1* overexpressors, due to reduced GA levels, have higher DELLA protein levels and are consequently more likely to have repressed germination. Indeed inhibition of *CBF* expression has been indicated as a requirement to promote germination (Kendall et al., 2011). Therefore, the low germination rates of *CBF* overexpressors observed is to be expected, especially in those expressing to a high level or with high activation ability which would result in reduction of numbers of individual transgenic lines or even total loss of those lines.

The aforementioned reduced GA expression, resulting in reduced breakdown of DELLA proteins, leads to a dwarf phenotype (Achard et al., 2008). This phenotype was frequently observed in plants grown from transformed seed. As well as a dwarf phenotype the lower leaves frequently curled down at the edges and tightly hugged the substrate, with leaves higher in the rosette hugging the leaves below. This likely led to the formation of humid microclimates on the leaf underside possibly encouraging pathogen attack and resulting in further plant losses. Likewise, *CBF* overexpression is known to increase the concentration of various sugars (Cook et al., 2004) which could make the overexpressor more susceptible to pathogen attack and preferential targets for consumption by fly larvae, coupled with leaves closer to the growth substrate. Flies were observed around the plants during line establishment and appeared to show preference for the *CBF* overexpressor plants. Others overexpressing *CBF* in *Arabidopsis thaliana* have also reported this problem with flies (pers. com. Dr. R. Oakenfull). Increased susceptibility to pathogen and pest attack could therefore also explain some of the losses observed and signs of pathogen and pest attack were observed (pers. obs.).

Dwarfing of plants led to smaller inflorescences which therefore produced less seed. Gal (involved in the GA biosynthesis pathway) knockout mutants also have sterile flowers (Tyler et al., 2004), therefore the reduced concentration of GA in *CBF* overexpressors

(Achard et al., 2008) may also result in reduced flower fertility, leading to lower seed amounts (Table 4.1.2.1.2).

Despite observations of late flowering in plants overexpressing *CBF1* (Achard et al., 2008, Gilmour et al., 2004). Early flowering was observed in these construct lines. It is possible that differing growth conditions or other environmental factor(s) (such as watering conditions, growth media etc) may alter the effect upon flowering time of *CBF1* overexpressors. This is supported by previous *CBF1* overexpressors from the same research group not displaying this delayed flowering phenotype ((Gilmour et al., 2004) in reference to Jaglo-Ottosen et al. (1998). Although not explicitly stated in Jaglo-Ottosen et al., (1998), Gilmour is also an author on this paper and it is therefore assumed her reference to this as a record of a lack of previous delayed flowering was an observation at the time). This indicates that other factors can affect the effect of *CBF1* upon flowering time. It is also possible that different *A. thaliana* accessions have different flowering time responses to *CBF1* overexpression; Columbia-0 was used in these experiments (early flowering phenotype), Jaglo-ottosen et al., 1998 used RLD (no change in flowering time), Gilmour et al., 2004 used Wassilewskija (late flowering) and Achard et al., 2008 used Landsberg *erecta* (late flowering). Indeed different accessions are known to have different freezing tolerances (Hannah et al., 2006, Cvetkovic et al., 2017) with Columbia-0 tolerating lower freezing temperatures after acclimation than Landsberg *erecta* (Hannah et al., 2006). Whereas, Wassilewskija tolerates lower temperatures than Col-0 after acclimation (Cvetkovic et al., 2017) (RLD was not tested) (Hannah et al., 2006, Cvetkovic et al., 2017). It has also been shown that exposure of Col-0 and Wassilewskija to cold (which would result in the upregulation of *CBF* (Gilmour et al., 1998)) can induce early bolting (Cvetkovic et al., 2017). However, this earlier bolting in response to prior cold exposure is not consistently seen each year (Cvetkovic et al., 2017) indicating that other factors also affect the time until bolting and whether cold exposure induces early bolting.

It seems likely, therefore, that either some element of the growth conditions in this project and previous projects within the Knight group (pers. com.) promoted early flowering in *CBF1* overexpressors, not seen in experiments from other labs and/or that it is due to the use of a different accession (Col-0). This early flowering resulted in greatly reduced seed numbers, or in some cases where the plant was very small, death likely due to insufficient energy resources prior to seed set. Plants transformed with the PKK mutation appeared to be more severely affected. This could indicate that the PKK mutation is highly damaging, possibly by strong binding to the CRT/DRE element (as discussed in section 4.2.1). This is supported by the only PKK line that survived having very low expression (Fig. 4.1.2.2.1 and 4.1.2.2.2). Therefore, it is possible that all higher expressors of the PKK mutation were not viable.

4.2.2.2 Levels of *CBF* and *COR* Gene Expression in Stable Transformed *Arabidopsis thaliana* Lines

LTI78 (also known as *RD29A* or *COR78*) and *KIN2* (*COR6.6*) are both *COR* genes with the CRT/DRE regulatory promoter element (Yamaguchi-Shinozaki and Shinozaki, 1994, Nordin et al., 1993) and upregulated by *CBF1* (Gilmour et al., 2004). Therefore, that the fold increase in expression in these genes, relative to wildtype, remains consistent between the two genes for each line is unsurprising (Fig. 4.1.2.2.2 and Fig. 4.1.2.2.1). The exception (the highest overexpressor of *CBF* - a DSAWQ line with a 2057 fold increase in *CBF* expression) had the highest expression of *LTI78* of all plants studied whereas it was the 5th highest expresser of *KIN2* (Fig. 4.1.2.2.2 and Fig. 4.1.2.2.1). This is unlikely to be a peculiarity of DSAWQ as other DSAWQ lines did not show this pattern (Fig. 4.1.2.2.2 and Fig. 4.1.2.2.1). Therefore, it seems likely that this response has something to do with the large overexpression of *CBF*. *LTI78* has 4 copies of the DRE/CRT element (Nordin et al., 1993) whereas *KIN2* has 1 (Wang et al., 1995).

Therefore, it is possible that, dependent upon the positioning, these extra DRE/CRT elements result in a higher expression of *LTI78*, under normal circumstances, than *KIN2*. It is therefore possible that upon reaching very high expression levels of *KIN2* another factor is downregulating *KIN2* expression, whereas the possibly much higher expressed *LTI78* may not have a down-regulatory gene that responds to *LTI78* concentrations or downstream responses. It is also possible that very high overexpression of *CBF* is activating other genes which, at high concentrations are influencing *KIN2* expression but not *LTI78*. It is not known exactly what *LTI78* and *KIN2* do in the plant, so a mechanism for this cannot be proposed.

All lines were compared to expression levels in wildtype, which was set arbitrarily as 1. Several lines have error bars which overlap 1 for both *CBF* and *KIN2* or *LTI78* expression. It is possible some lines were not successfully transformed, despite selection on hygromycin, as this weakens rather than directly kills the untransformed seedlings. An alternative is that only partial transformation may have occurred resulting in hygromycin resistance but not insertion of the synthetic *CBF* gene. Another alternative is that the gene may have inserted into an inactive section of the genome. Interestingly some lines show less than 1 for *CBF* expression (i.e. less than wild-type) even accounting for error bars, but higher than 1 for *COR* gene expression (*KIN2* or *LTI78*). It would be expected that non-transformed plants or non-expressors would show the same profile as untransformed wildtype (i.e. 1). An example of this is a DSLWR line which has a fold change of 0.20 in *CBF* but 3.70 in *KIN2* with error bars not overlapping the fold change of 1 (Fig. 4.1.2.2.1). A line overexpressing wildtype *CBF1* also has a *CBF* expression clearly less than 1 (0.18) with no overlap of error bars with 1 and a *COR* gene expression of either 1.00 (Fig. 4.1.2.2.2) or 1.88 (Fig. 4.1.2.2.1). This indicates that this is not a response due to the mutation in synthetic *CBF* genes, since the wildtype *CBF1* overexpressors have a synthetic gene identical to their native *CBF1*. The same amount of RNA is used in qPCR

so this cannot affect results. The time from sowing of the seed to RNA extraction is the same for all plants so in theory the seedlings should all be the same age. However, as previously discussed (section 4.2.2.1), *CBF* overexpression can result in dwarfing and delayed germination. Therefore, *CBF* overexpressing plants may be at a different growth stage to their wildtype control if there is a delay in germination and/or altered growth rate (e.g. dwarfing). This would result in a different ratio of different tissues which would result in different RNA expression. Another possible, but less likely, compounding factor is that although all plates were grown in the same growth cabinet where conditions should all be the same the exact location of the light strips and slight fluctuations in MS media firmness could also affect growth form and rate also affecting RNA expression. Therefore, as well as resulting in fold changes that appear less than wildtype, those which appear to be the same as wildtype may not necessarily be non-transformed or non-expressors.

From the scatter graphs there was no apparent difference or clear pattern that indicates any mutation results in greater *COR* gene expression for a relative level of *CBF* expression than any other (including wildtype) (Fig 4.1.2.2.1 and 4.1.2.2.2). However, when the ratio of fold increase in *COR* gene expression relative to wildtype over the fold increase in *CBF* expression relative to wildtype was taken (Fig. 4.1.2.3.1), DSLWR was shown to be expressing *COR* genes to a greater level for a relative level of *CBF* expression when compared to wildtype *CBF* overexpressors. This could indicate that the DSLWR mutation (from DSAWR -> DSLWR) more strongly activates *COR* genes, either via stronger binding or increased activity, which fits with the results seen from transient expression (see sections 4.1.1 and 4.2.1). However, there were only four independent lines expressing the DSLWR construct. These four independent lines are all low expressors, with a maximum *CBF* expression fold increase of 1.5 (Fig. 4.1.2.2.1 and 4.1.2.2.2) (which explains why a clear trend could not be seen from the scatter graphs

alone). One of these lines is also the aforementioned very low expressor of *CBF* with high *COR* gene expression. As discussed in transient expression (Section 4.2.1), expression levels of *CBF* to *COR* gene are not linear (neither are they logarithmic); at high levels of *CBF* expression relative *COR* gene expression drops, this can also be seen on the scatter graphs (Fig. 4.1.2.2.1 and 4.1.2.2.2). This tending towards a plateau, or even drop, in expression at higher levels would bring the averages down for all lines with higher expression. Therefore, DSLWR not having and high *CBF* expression examples, whereas there were high *CBF* expression samples for the wildtype *CBF1* overexpressor, could mean that for DSLWR the average is not brought down by the higher expressors resulting in an apparent higher expression level. A way to address this problem would be to transform and establish more DSLWR lines, hopefully obtaining some high expressors, along with increased numbers of lines for other synthetic genes, including the PKK line. With a wide range of evenly distributed expression levels of *CBF* for each line, expression could be compared over different ranges of *CBF* expression as well as comparing the shift of any potential curves, as was the original intent. However, there are other problems which result in greater errors within the data to overcome first, including the problem of growth stage after a certain number of days. One potential way to address this is the application of GA to speed up germination and overcome growth inhibition of *CBF* overexpressors, however GA greatly alters the transcriptome (e.g. (Ju et al., 2018, Upadhyay et al., 2018, Xie et al., 2016)) so would likely interfere with results to an even greater degree. All plants including controls would therefore have to be subjected to GA treatment and it is unknown how this may alter relative results. Cotlydon size rather than number of days could be used to assess the growth stage of the seedling prior to harvesting, however the effect of number of days growing and slight fluctuations in environment and time of harvesting may also affect the transcriptome, therefore the best approach is to still use seedlings of the same age but to remain aware of potential

limitations e.g. via noting any morphological differences at that stage. Comparison with *CBF1* overexpressors also helps to overcome this limitation to a degree with the exception that this limitation will be more pronounced for stronger binders/activators. Another limitation is that the data will include individuals within the lines which are not expressing i.e. non-transformed individuals. This is because RNA extraction was performed on T1 seedlings and this will be mixed population from a heterozygous parent so should include $\frac{1}{4}$ homozygous transformed, $\frac{1}{2}$ heterozygous and $\frac{1}{4}$ homozygous untransformed (i.e. wildtype). However as discussed in (Section 4.2.2.1) seeds which are overexpressing *CBF* (i.e. the transformed homozygotes and heterozygotes) are less likely to germinate and/or have delayed germination, they are also more likely to be dwarf and slow growing with potentially less genetic material. The more potent the gene and the greater the expression the greater this problem will be. Since a small number of seedlings are taken for RNA extraction (~10) this variation and bias towards untransformed individuals could easily skew expression results. One way to address this problem would be to extract from a large number of seedlings, however this would not account for the cumulative effect of more potent expressors having a greater skew towards germination and growth of the $\frac{1}{4}$ homozygous wildtype therefore altering the ratio of wildtype to non-wildtype. Therefore, the optimum way to address this problem would be the removal of the wildtype allele via the establishment of homozygous expressing lines.

4.2.2.3 Effect of Freezing Upon Transformed *Arabidopsis thaliana* lines and The Relation to *CBF* and *COR* Gene Expression

The only plants to completely survive the sudden freezing shock (at -7 °C) were dwarf plants, and all dwarf plants showed complete survival. These were lines 24 & 25 of DSAWQ and 21 of synthetic wild-type which all expressed *CBF* and *COR* genes to a relatively high level (Figs. 4.1.2.4.5 & 4.1.2.4.5). As previously discussed *CBF1*

overexpression leads to dwarfing (Achard et al., 2008) and *CBF1* overexpression results in increased freezing tolerance relative to non-acclimated plants (Jaglo-Ottosen et al., 1998) therefore, that dwarf plants survived and that these were high *CBF* expressors is unsurprising. Not all plants from these lines survived nor were they dwarf (4/12, 2/5 and 1/6 for DSAWQ 24, 25 and wildtype OE 25 respectively were dwarf and survived). This is likely due to the mixed population of offspring from the heterozygous parent namely that the offspring, if there is a single insertion of the transgene, should consist of $\frac{1}{4}$ homozygous transformed, $\frac{1}{2}$ heterozygous and $\frac{1}{4}$ homozygous untransformed (i.e. wildtype). Therefore, given random selection $\frac{3}{4}$ of the offspring seedlings should be *CBF1* overexpressors. This is not the case $\frac{1}{4}$, $\frac{2}{5}$ and $\frac{1}{6}$ is seen. The imbalance seen is likely due to the aforementioned (section 4.2.2.1) inhibited and/or delayed germination and growth of *CBF* overexpressors as well as reduced survival. Indeed, it was noted that DSAWQ L24 had a highly variable range of seedling sizes and poor germination (Section 4.1.2.4). Whilst during selection an attempt was made to select a range of sizes of seedlings representing the proportions on the plate, this would not always be perfect, with larger plants giving the impression of a larger proportion. Also, if some seeds did not germinate, their percentage was not counted with the smaller seedlings. Therefore, this would very likely skew the expected ratio of seedlings towards the untransformed individuals. This could also explain the lack of representation of two other lines with high expression of *LTI78* and *KIN2* (namely wildtype overexpressor line 14 and DSAWQ line 15 highlighted in yellow Fig. 4.1.2.4.5 & 4.1.2.4.6) for which no examples survived freezing, nor did they any examples with a dwarf phenotype. These lines did however have lower *CBF* expression than some lines which express *LTI78* and *KIN2* to a lesser degree (including members of the same construct – i.e. DSAWQ lines and wildtype overexpressing lines). It is therefore possible that, although *LTI78* and *KIN2* have been

expressed to high levels in these lines, other *COR* genes may not be as highly activated; this is however, unlikely.

A couple of lines showed partial freezing tolerance; these were DSAWQ L20 and L23 (2/12 and 1/12 plants respectively). These plants were large, non-dwarfed plants and only showed partial green survival of the central meristem. These lines were both low expressors of *CBF* and *COR* genes (Fig. 4.1.2.4.5 & 4.1.2.4.6). That these were also DSAWQ lines is interesting (DSAWQ being the only line to show dwarfing and complete survival except for a wildtype overexpressor), this could indicate that the DSAWQ mutation induces greater freezing tolerance, even with lower apparent expression of *CBF* and *COR* genes (*KIN2* and *LTI78*), perhaps via preferential upregulation of specific *COR* genes at the expense of others (such as *KIN2* and *LTI78*), or that this line suffers particularly from the limitations discussed in section 4.2.2.2 resulting in an apparent lower expression via preferential selection of wildtype plants. However other low expressing DSAWQ lines were also tested and this improved freezing tolerance with no dwarfing was not seen (Fig. 4.1.2.4.5 & 4.1.2.4.6). It is possible that this is due to positioning in the freezer, in both cases the DSAWQ 120 plants that showed partial survival were in corners of the trays (Fig 4.1.2.4.4a&b), and the DSAWQ 123 plant that showed partial survival was on an edge (Fig 4.1.2.4.4b). It is possible that, they were therefore furthest from the chilling element or close to a possible leak in the door seal and may have experienced marginally warmer temperatures than other plants.

Unfortunately, due to the limitations of this experiment and the high mortality rate, no conclusions can be firmly drawn about the efficacy of various mutations relative to wildtype. The high mortality upon freezing resulted in survival of only very high expressing, dwarfed individuals. It is possible therefore that a higher temperature could perhaps distinguish between lower expressors. The plants were subjected to -7 °C for 24 h followed by 24 h at 5 °C then placed back in growing conditions and photographed after

3 days. Hannah et al., (2006) found that the LT50 for wildtype Col-0 plants grown in 16-h photoperiod with a day/night temperature of 20 °C/18 °C was -5 °C for non-acclimated and -10 °C for acclimated plants. Therefore -7 °C should be a good test temperature. However, although these test plants were grown in the same photoperiod, they were transferred from a -20 °C growth room to a higher temperature growth room (~23 °C) due to refurbishment of the previous growth room. They also would not experience the cooler night time temperatures of the plants studied by Hannah et al., (2006). The plants were therefore accustomed to a higher temperature and the change to -7 °C was therefore a much greater relative drop than those tested by Hannah et al., (2006). There were also signs of stress in the test plants prior to freezing (especially evident in Figs. 4.1.2.4.4a-c in the form of leaf yellowing), likely due to higher temperatures. Therefore, future tests may give better results if plants were grown at a temperature of 20 °C day /18 °C night prior to freezing tests at -7 °C or, if higher growing temperatures were necessary, if higher freezing temperatures were also used.

Chapter 5: Natural Variation in *Empetrum nigrum* and *Calluna vulgaris* from Differing Environments

Aims and Objectives

The aim of this chapter was to investigate whether species which grow across a wide environmental range have local genetic adaptations which may alter their freezing tolerance response. Therefore, the objectives were: to explore the possibility of establishing a model Arctic or alpine plant; to isolate and compare CBF sequences from a single species across a wide environmental range; to assess the possibility of using chlorophyll content as a proxy of damage for freezing tests on *Empetrum nigrum* and *Calluna vulgaris*; to adapt and assess the feasibility of using qPCR to study CBF expression kinetics in *Empetrum nigrum* from samples across a wide environmental gradient.

Hypotheses:

12. Polymorphisms exist within CBF sequences from the same species.
13. Polymorphisms in CBF within the same species are associated with the environmental conditions of the site of their collection.
14. CBF expression kinetics differ across the environmental range of a species.
15. Different morphologies observed in common garden grown cuttings of *Empetrum nigrum* and *Calluna vulgaris* are due to the influence of the environmental origin of the parent donor plant.

5.1 Results

5.1.1 Establishment of Arctic/Alpine Model Plants

Growth of alpine plants in the attempt to establish a model plant for study (section 2.2.1) proved unsuccessful. Germination was unreliable, and many plants were lost due to mechanical and software failure of growth chambers. Of those that did survive, growth was slow combined with being slow to flower (and therefore produce seed) alongside a lack of consistency in flowering time. *Dryas octopetala* showed the most rapid flowering time of around 2 years after germination. *CBF* sequences could also not be isolated from these species. However, had other criteria been met, full genome sequencing would have been performed allowing for identification of *CBF* genes.

5.1.2 *CBF* Sequence Comparison from *Empetrum nigrum* Plants from Differing Environments

There was a high degree of conservation across all *Empetrum nigrum CBF* nucleotide sequences (Fig. 5.1.2.1a-f). Of the differences seen there was no apparent link between these and the location the sample was collected from (country or altitude or noted surroundings). These differences also are not linked (i.e. having one does not change the likelihood of having another).

Once translated, the sequences had even greater conservation (Fig. 5.1.2.2a-b). The key differences (only those seen in more than one sequence) were at amino acid 109 and 148 (using top sequence for count) (Fig. 5.1.2.2a-b). At amino acid 109 there was an unconserved substitution with some sequences having P, some L and some both (X) (Fig. 5.1.2.2a-b). At amino acid 148 another substitution occurs, some sequences have M, some T and some both (X), one sequence (158) has K rather than M or T (Fig. 5.1.2.2a-b). The

148 M substitution is always associated with 109 P. However, 109 P is not always associated with 148 M. There was no link between these alleles and the location the sample was collected from (country or altitude or noted surroundings).

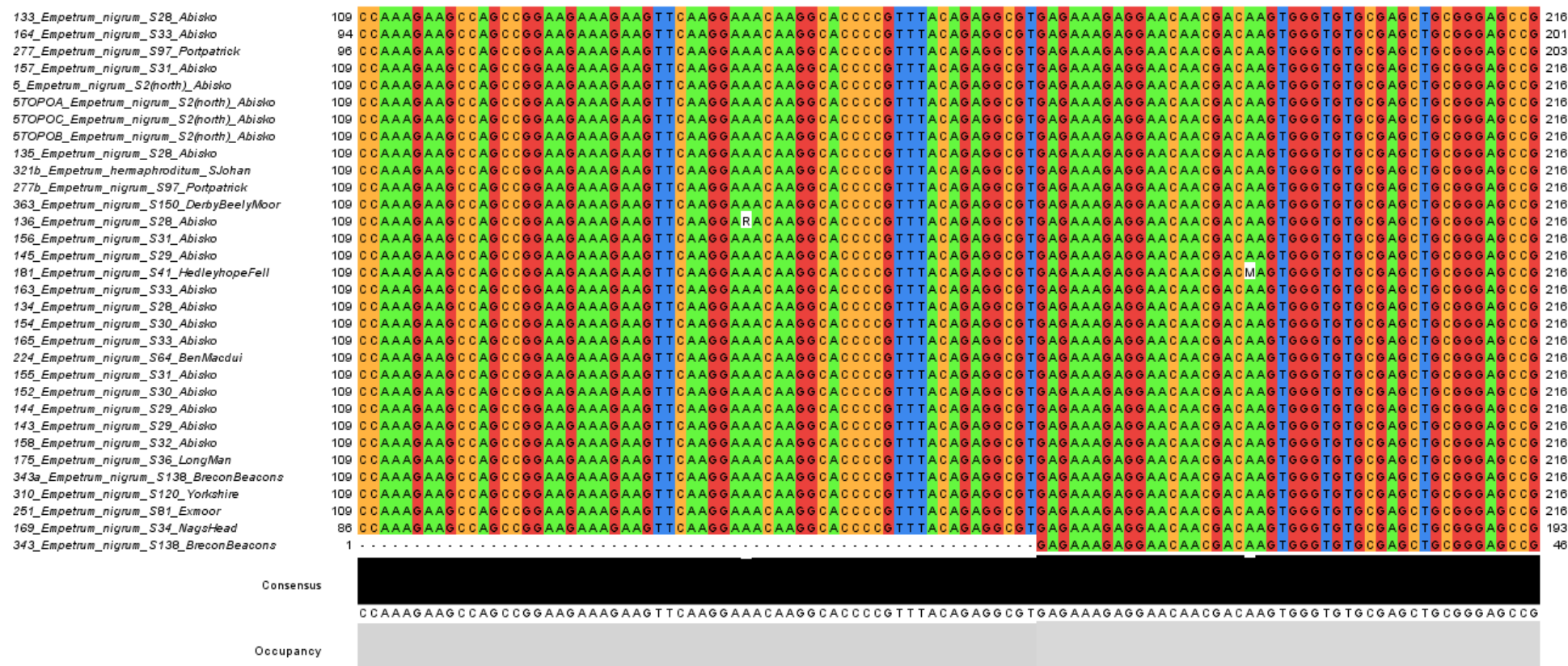

Figure 5.1.2.1 b. Clustal alignment of *CBF* nucleotide sequences isolated from *Empetrum nigrum* samples. Sequences are ordered by Clustal sorting. Names are in the form “Species code_Genus_Species_Site code_Location” TOPO indicates that the sequence was isolated via TOPO cloning. Consensus bar shows degree of consensus between sequences, occupancy bar shows degree of nucleotide presence at that site.

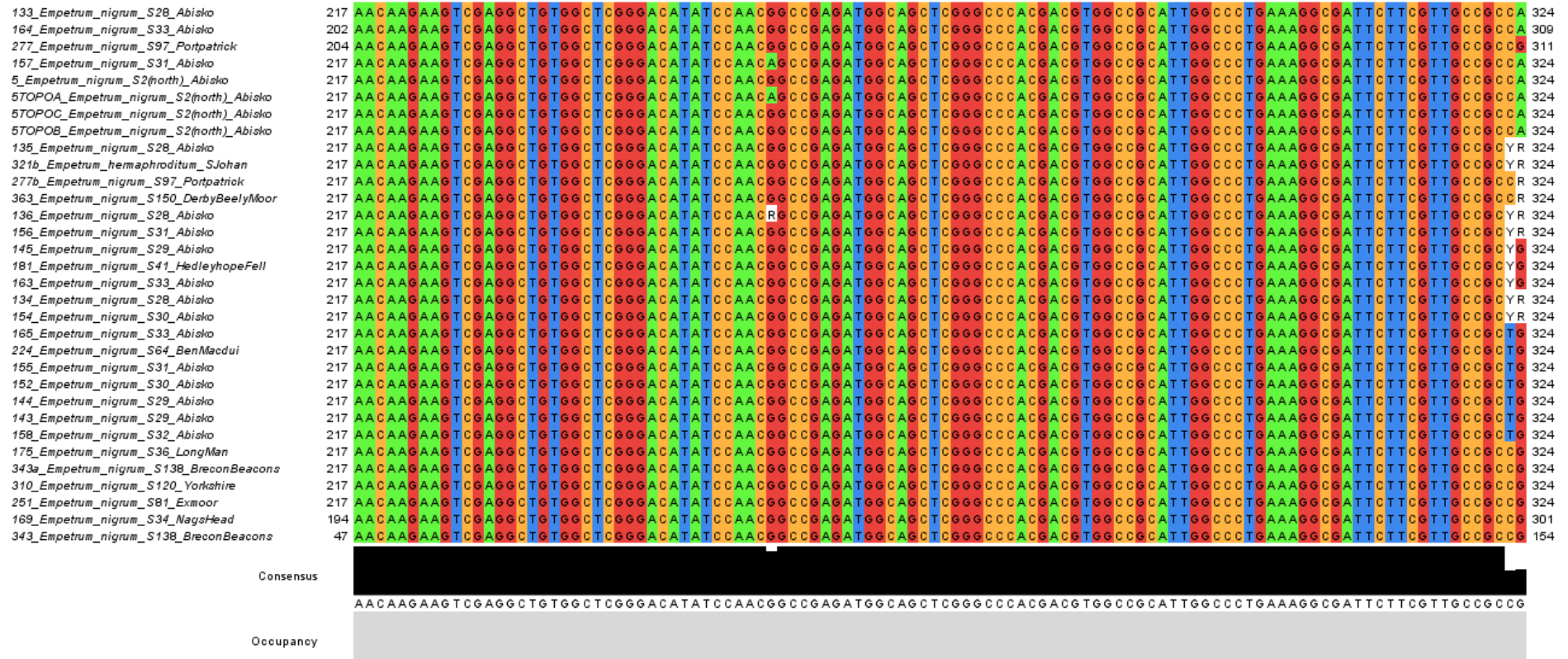

Figure 5.1.2.1 c. Clustal alignment of CBF nucleotide sequences isolated from *Empetrum nigrum* samples. Sequences are ordered by Clustal sorting. Names are in the form “Species code_Genus_Species_Site code_Location” TOPO indicates that the sequence was isolated via TOPO cloning. Consensus bar shows degree of consensus between sequences, occupancy bar shows degree of nucleotide presence at that site.

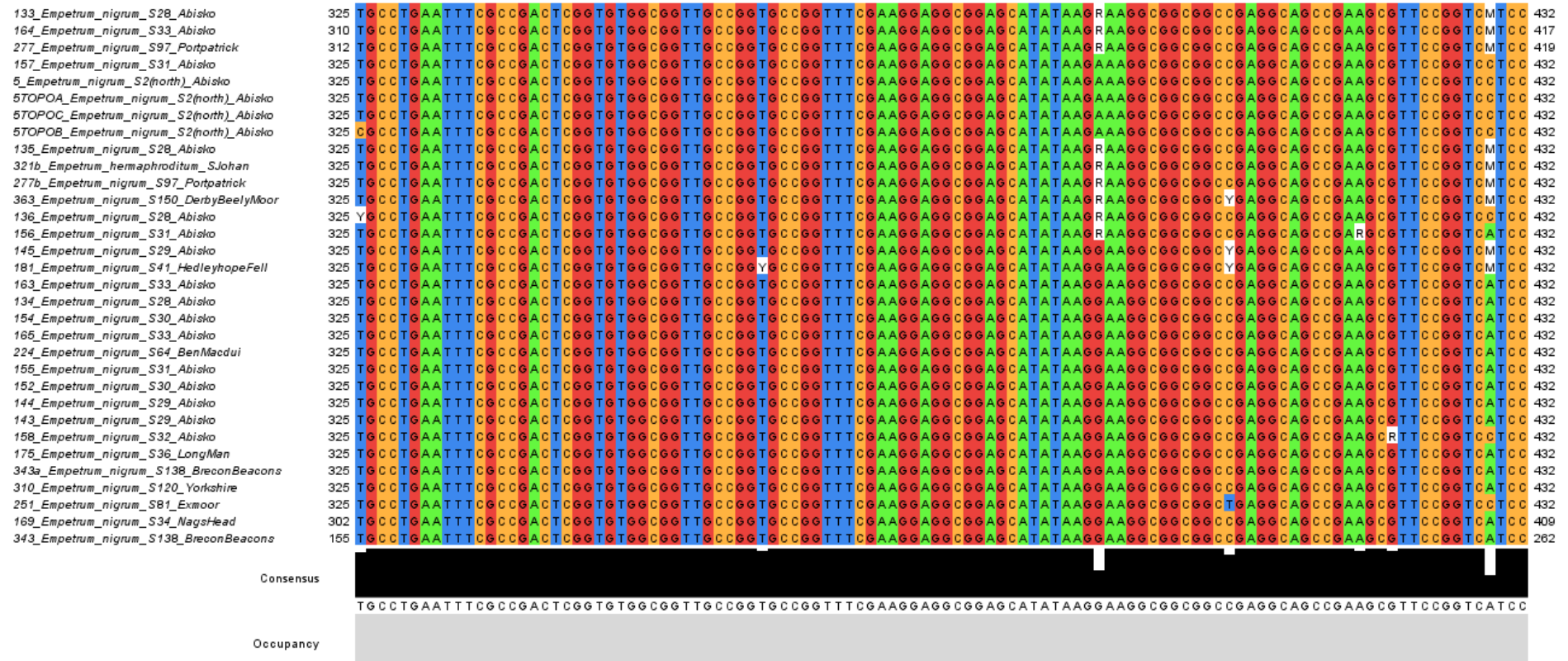

Figure 5.1.2.1 d. Clustal alignment of *CBF* nucleotide sequences isolated from *Empetrum nigrum* samples. Sequences are ordered by Clustal sorting. Names are in the form “Species code_Genus_Species_Site code_Location” TOPO indicates that the sequence was isolated via TOPO cloning. Consensus bar shows degree of consensus between sequences, occupancy bar shows degree of nucleotide presence at that site.

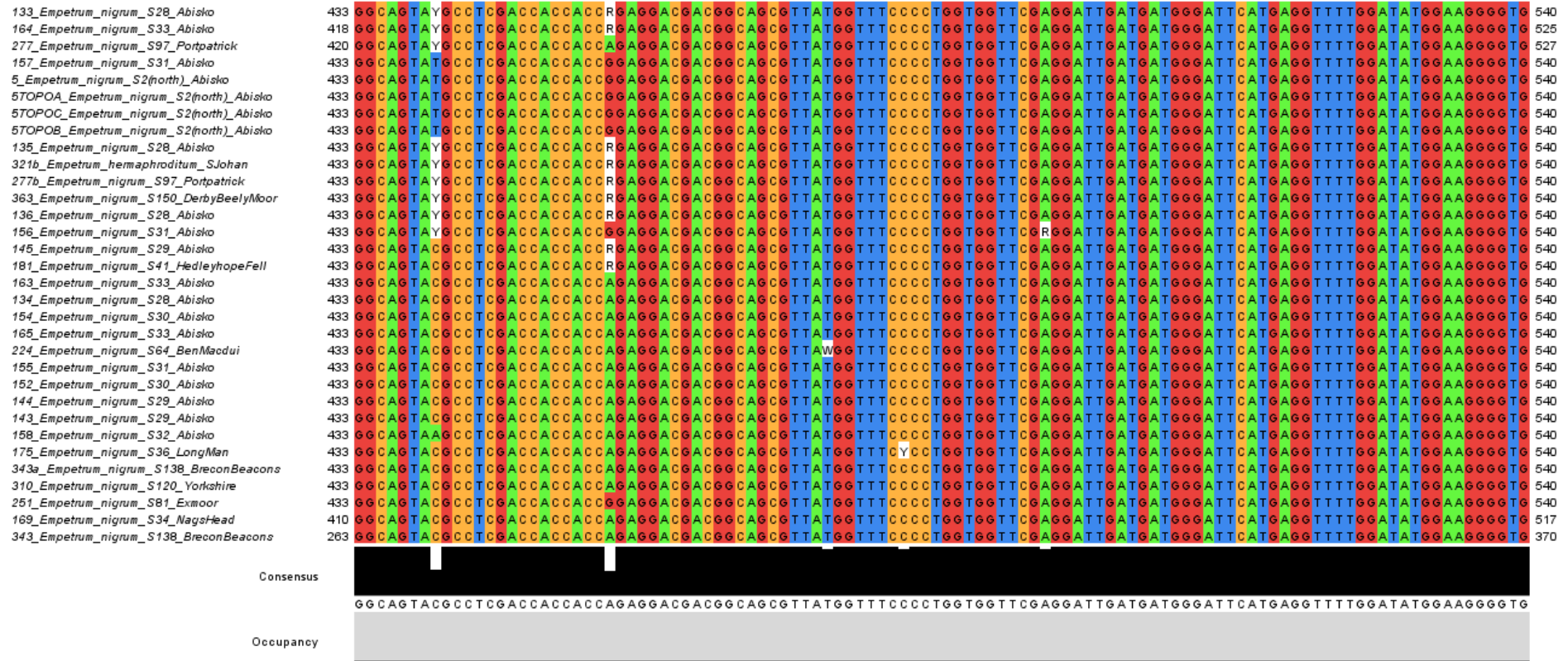

Figure 5.1.2.1 e. Clustal alignment of *CBF* nucleotide sequences isolated from *Empetrum nigrum* samples. Sequences are ordered by Clustal sorting. Names are in the form “Species code_Genus_Species_Site code_Location” TOPO indicates that the sequence was isolated via TOPO cloning. Consensus bar shows degree of consensus between sequences, occupancy bar shows degree of nucleotide presence at that site.

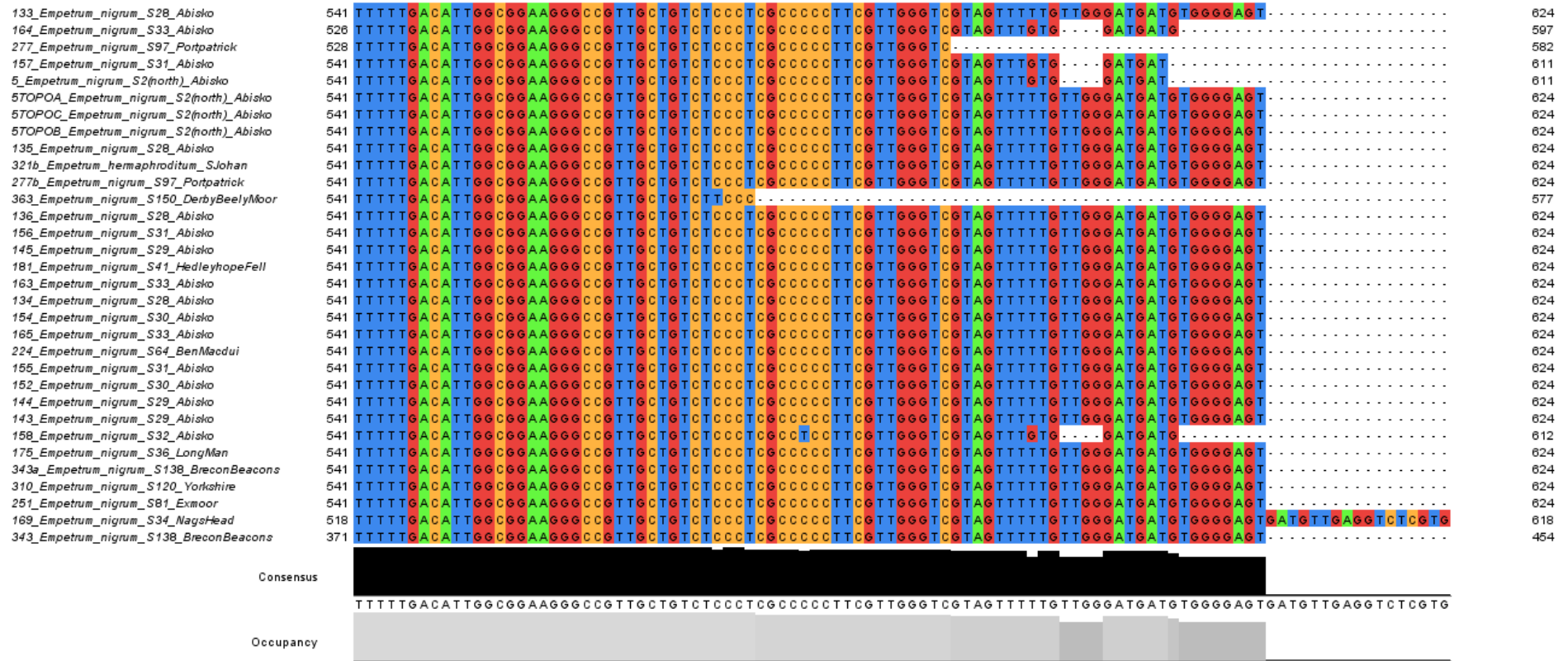

Figure 5.1.2.1 f. Clustal alignment of *CBF* nucleotide sequences isolated from *Empetrum nigrum* samples. Sequences are ordered by Clustal sorting. Names are in the form “Species code_Genus_Species_Site code_Location” TOPO indicates that the sequence was isolated via TOPO cloning. Consensus bar shows degree of consensus between sequences, occupancy bar shows degree of nucleotide presence at that site.

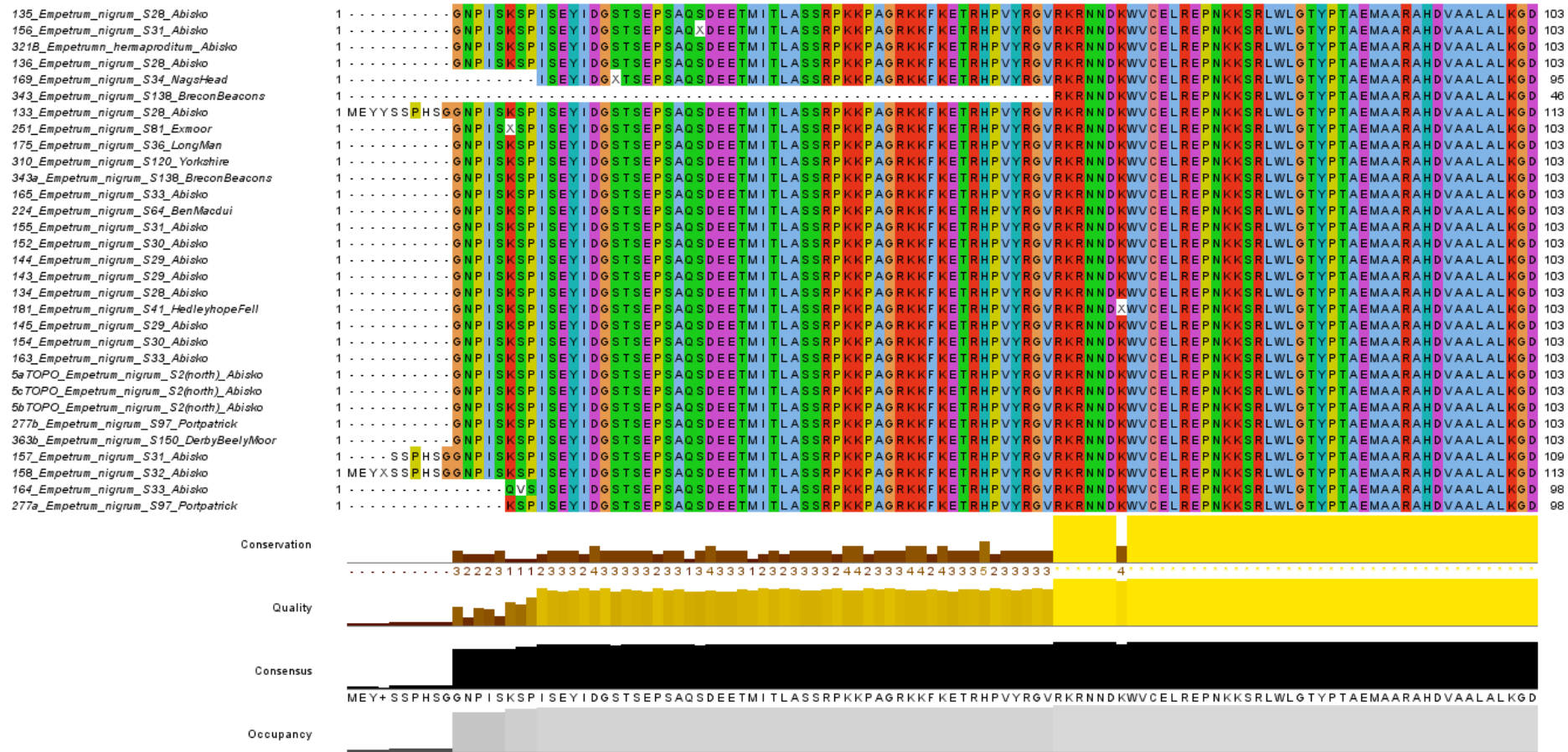

Figure 5.2.1.2 a. Clustal alignment of translated CBF nucleotide sequences isolated from *Empetrum nigrum*. Sequences are ordered by Clustal sorting. Names are in the form “Sample code_Genus_Species_Site code_Location”. TOPO indicates that the sequence was isolated via TOPO cloning. Conservation histogram indicates the degree of conservation of physicochemical properties between sequences, quality histogram indicates the likelihood of observing mutations at that point, consensus histogram shows degree of consensus between sequences and to the auto-calculated consensus below, occupancy bar shows degree of nucleotide presence at that site.

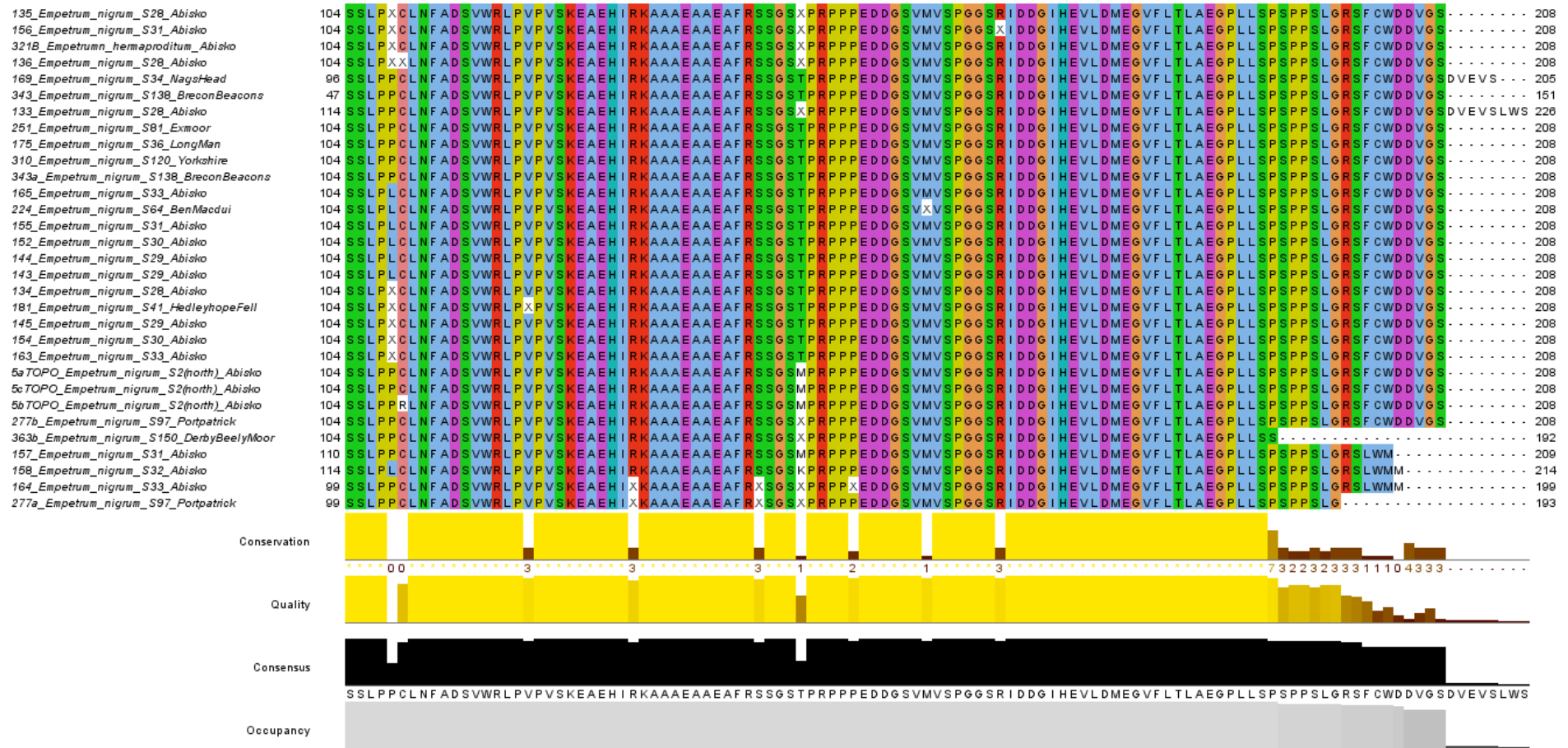

Figure 5.1.2.2 b. Clustal alignment of translated CBF nucleotide sequences isolated from *Empetrum nigrum*. Sequences are ordered by Clustal sorting. Names are in the form “Sample code_Genus_Species_Site code_Location”. TOPO indicates that the sequence was isolated via TOPO cloning. Conservation histogram indicates the degree of conservation of physicochemical properties between sequences, quality histogram indicates the likelihood of observing mutations at that point, consensus histogram shows degree of consensus between sequences and the auto-calculated consensus below, occupancy bar shows degree of nucleotide presence at that site.

5.1.3 CBF Expression in *Empetrum nigrum*

5.1.3.1 Identification, Design and Testing of Primers for use in qPCR on cDNA from *Empetrum nigrum*

Table 5.1.3.1.1. Testing newly designed real time primers with *Empetrum nigrum* cDNA. Showing A. CT values and B. TM values from q-PCR for four different real-time primers sets. Two designed to amplify from previously isolated and sequenced *Empetrum nigrum* CBF gene (Section 5.1.2) CBF(1) (primer pair 166+167) and CBF(2) (primer pair 168+169) and two designed to amplify *RPB2I* gene RPB2Ia (primer pair 170 + 171) and RPB2Ib (primer pairs 172 +173) See 2.5.1.1. *Empetrum nigrum* sample 232 cDNA was used along side No Reverse transcriptase (NRT), and no template control (NTC) control.

A. CT Values				
	CBF(1) (166+167)	CBF(2) (168+169)	RPB2Ia (170 + 171)	RPB2Ib (172+173)
cDNA	27.7923	29.1057	Undetermined	31.7811
cDNA	25.1645	28.6158	Undetermined	28.185
cDNA	24.8097	28.3155	Undetermined	27.0379
NRT Control	23.5356	28.4306	36	25.1799
NRT Control	23.5977	28.7515	30.7635	25.0653
NRT Control	23.8078	28	35.6571	25
NTC Control	38.5218	Undetermined	Undetermined	Undetermined
NTC Control	Undetermined	Undetermined	Undetermined	Undetermined
NTC Control	36	Undetermined	Undetermined	Undetermined

B. TM Values				
	CBF(1) (166+167)	CBF(2) (168+169)	RPB2Ia (170 + 171)	RPB2Ib (172+173)
cDNA	83.9	80.1	76.9	78.1
cDNA	83.9	79.9	77.9	78.3
cDNA	84.2	79.9	69.8	78.3
NRT Control	83.9	79.9	86.3	77.9
NRT Control	83.9	79.7	77.4	77.6
NRT Control	83.9	79.7	77.6	77.9
NTC Control	77.9	70.7	70.9	69.8
NTC Control	70.4	74.9	74	74.9
NTC Control	77.6	73.6	70	70

Initial tests were performed on the novel primers designed to amplify *CBF* and *RPB2I* from *Empetrum nigrum* RNA (Table 5.1.3.1.1). Between the two *CBF* primers CBF(1) had the highest TM which was furthest from the TMs of the *RPB2I* primers averaging 84 °C compared to 80 °C for CBF(2) with *RPB2I* average TMs being 72.5 °C for RPB2Ia and 78.2 °C for RPB2Ib. There was a great deal of variation in the TM of RPB2Ia with a

maximum difference of 8.1 °C vs a maximum difference of 0.2 °C for RPB2Ib, 0.3 °C for CBF(1) and 0.2 °C for CBF(2). T_M values indicate the temperature at which 50 % of the cDNA will disassociate and become single stranded allowing primer binding and amplification. When comparing between two genes (housekeeping and test gene) similar T_M values are desirable so that amplification occurs at a similar temperature.

Some amplification was seen in the no template control for CBF(1) primers however the CT values (the number of cycles at which a set amount of amplification occurs) were very high and close to the maximum number of cycles (40), a slightly higher CT target value would have also have lead to these being registered as undetermined (Table 5.1.3.1.1).

Amplification in the no reverse transcriptase control (a control to test for amplification from genomic DNA contamination that was not removed during RNA isolation rather than amplification from cDNA) was greater than from the cDNA when using CBF(1) primers, averaging 23.6470 cycles to reach the set amount of amplification vs 26.9222 cycles for the cDNA. CBF(2) however showed close to equal amplification between the no reverse transcriptase control and amplification from cDNA averaging 28.3940 for the control and 28.6790 for cDNA. Again a great deal of variation was seen between the repeats for CBF(1) primers with a maximum difference of 2.9826 cycles vs a maximum difference of only 0.7902 cycles for CBF(2) primers (Table 5.1.3.1.1).

RPB2Ia primers showed no amplification from the cDNA and minimal amplification from the no reverse transcriptase control. RPB2Ib primers did amplify from cDNA however they showed great variation in CT values with a maximum difference of 4.7432 cycles. The no reverse transcriptase also showed greater amplification than the cDNA averaging 25.0817 cycles vs 29.0013 cycles for cDNA (Table 5.1.3.1.1).

Primer pairs CBF(2) and RPB2Ib were therefore selected as the primers to use for further experimentation.

5.1.3.2 Identification of the Optimal *Empetrum nigrum* cDNA Dilution for qPCR

A steady increase in both CT and TM value was seen (Fig. 5.1.3.2.1) with increasing dilutions of cDNA for both primer pairs. Variability in results, as indicated by error bars, increased from the 1:50 dilution for CBF primers and from 1:100 for RPB2I.

The dilution factor of 1:20 was, therefore, selected for future real-time experiments.

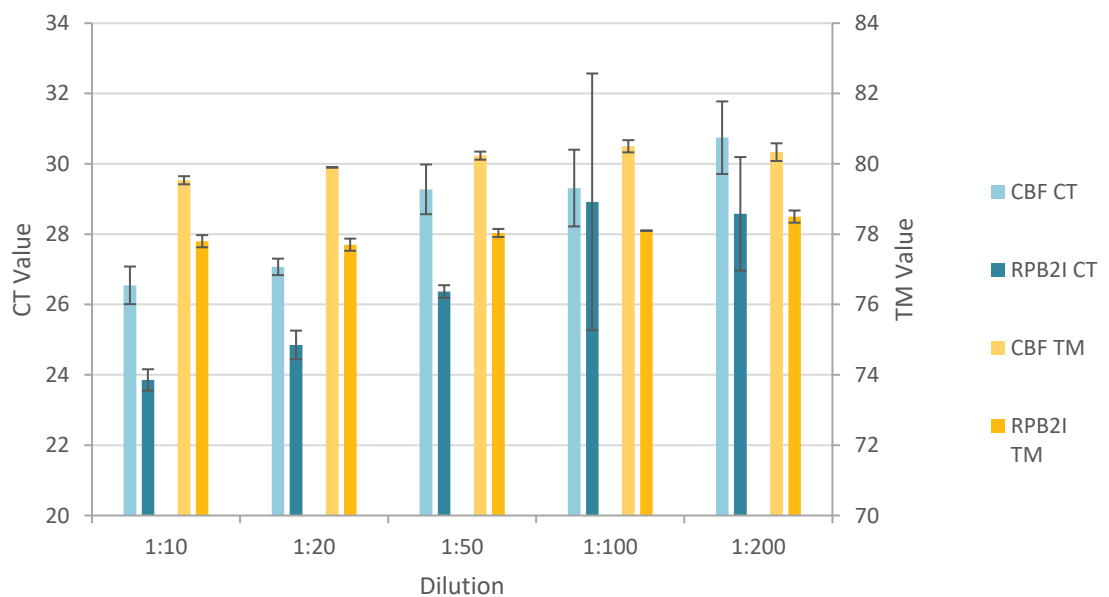

Figure 5.1.3.2.1. Showing CT values (blue) and TM values (orange) for several dilutions of *Empetrum nigrum* sample 232 cDNA, for both CBF primers (Pale) and RPB2I primers (Dark). Error bars show standard deviation of the mean of three technical repeats.

5.1.3.3 Effect of chilling upon *CBF* Expression in *Empetrum nigrum*

Expression of *CBF* decreases (0.18X that of fresh tissue) after being clipped from the plant and submerged in ice for 3 hours with no overlap of error bars (Fig 5.1.3.3.1).

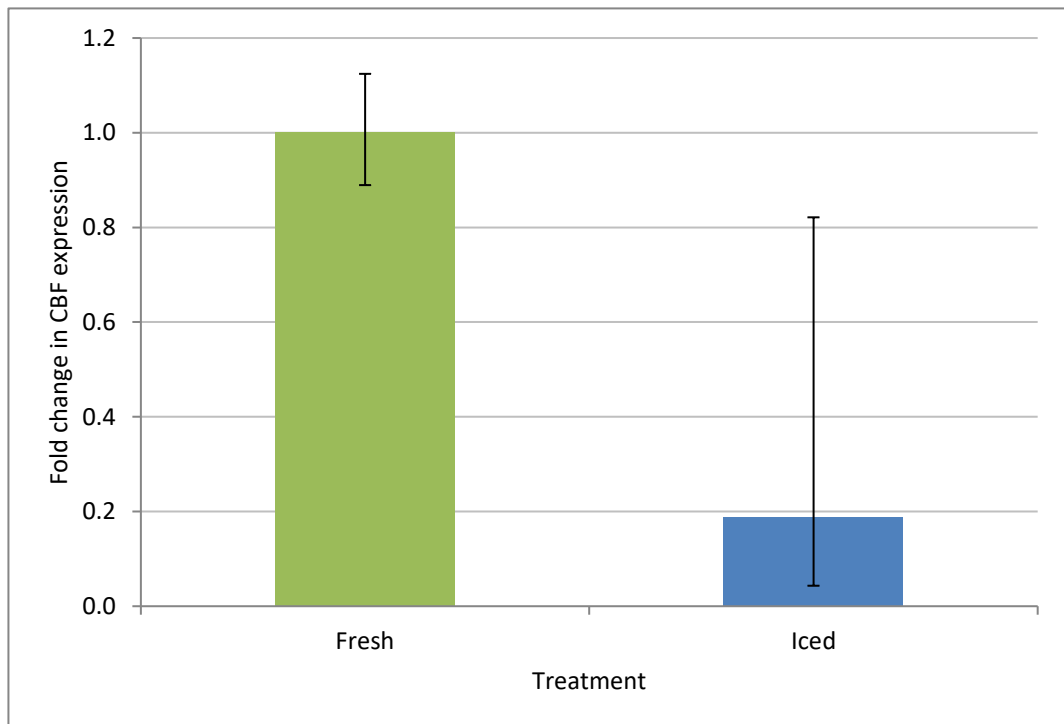

Figure 5.1.3.3.1. Showing fold change in *CBF* expression in *Empetrum nigrum* plant 310 (nr. Hutton-le-hole, Yorkshire, England 159m altitude) between RNA extracted from tissue freshly cut vs RNA from tissue cut from the plant and subjected to burial in ice for 3 h. RNA from fresh tissue is normalised to 1. Error bars show standard error of three technical repeats.

5.1.3.4 Kinetics of *CBF* Expression in Response to Chilling in *Empetrum nigrum* Between Plants Originating From Different Environments

5.1.3.4.1 qPCR Amplification Irregularities

Amplification irregularities occurred with the timecourse at 2 h from both sample 232 and 251 (highlighted in red; Fig. 5.1.3.4.1.1). There is apparently extremely rapid amplification of 232 2hCBF (within the second cycle) and similar rapid amplification from around cycle 13 of 251 2hCBF and RPB2I. A repeat of this experiment with a new dilution of both 2hsamples produced similar irregularities (Fig. 5.1.3.4.1.2) however the extremely rapid amplification of 232 2h within the second cycle is with the housekeeping RPB2Ib primers on this occasion and 251 2h*CBF* showing rapid amplification then drops off.

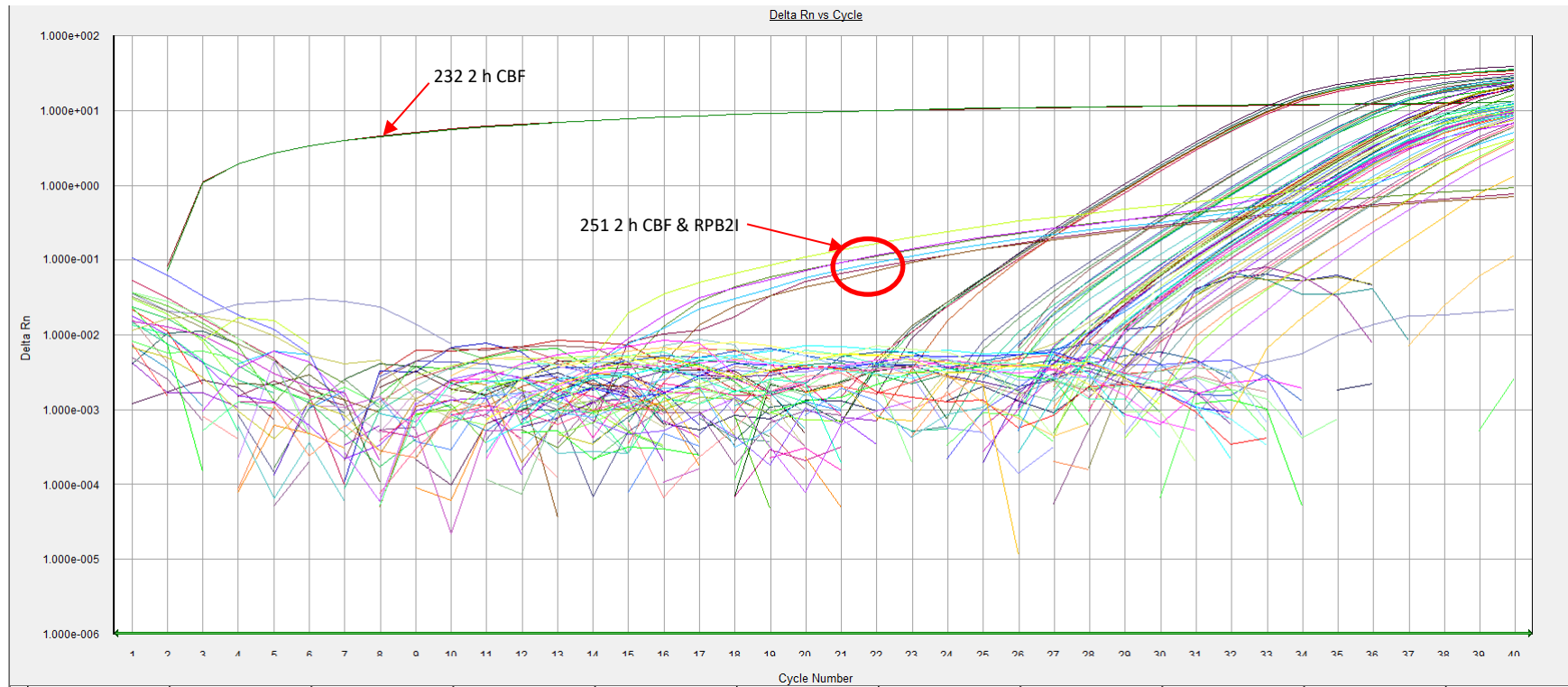

Figure 5.1.3.4.1.1 Realtime amplification plot 1 corresponding with Fig. 5.1.3.4.2.1. Showing amplification of CBF and RPB2I per PCR cycle (X axis). Each coloured line represents one well. Each reaction is repeated across three wells. Unusual amplification patterns are highlighted.

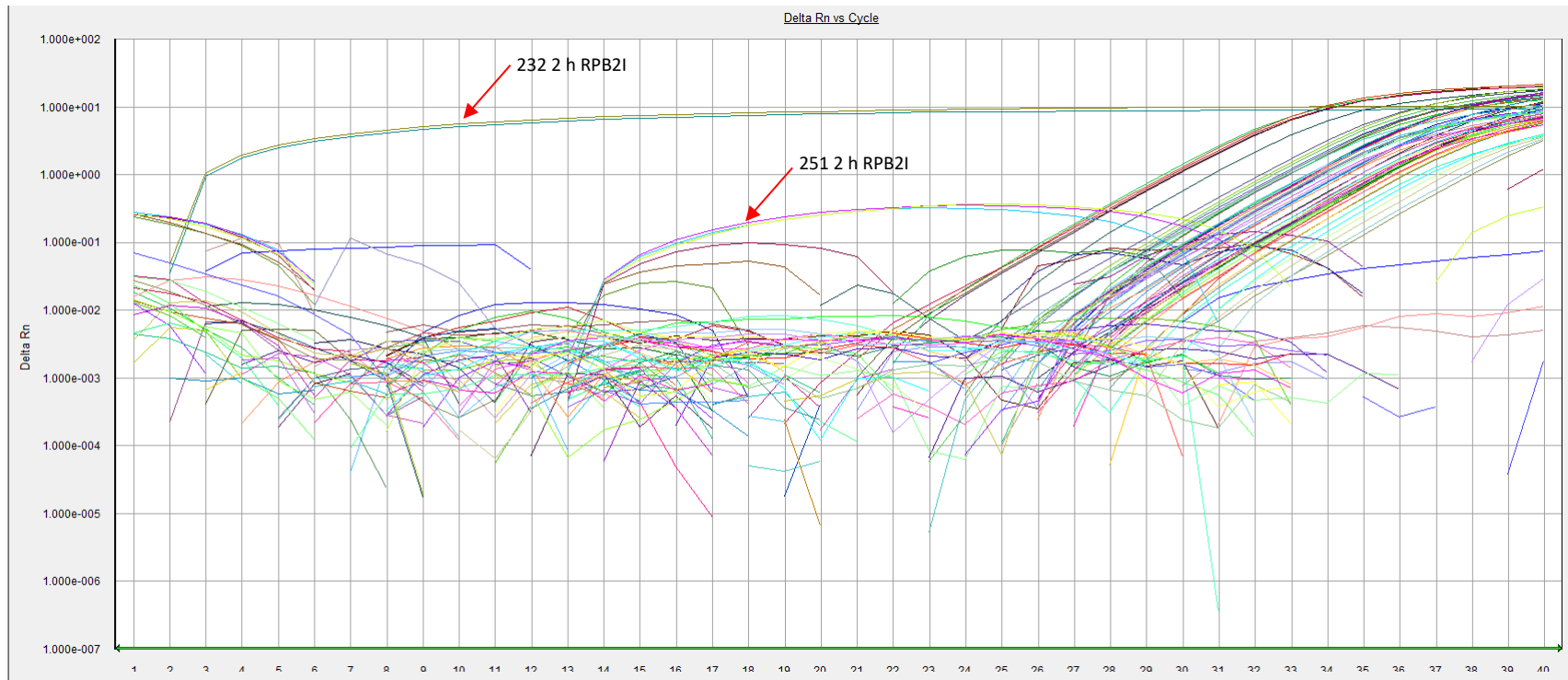

Figure 5.1.3.4.1.2 Realtime amplification plot 2 corresponding with Fig. 5.1.3.4.2.2. Showing amplification of CBF and RPB2I per PCR cycle (X axis). Each coloured line represents one well. Each reaction is repeated across three wells. Unusual amplification patterns are highlighted.

5.1.3.4.2 Results

Several results were discounted, namely 232 2h (from both Fig. 5.1.3.4.2.1 & Fig. 5.1.3.4.2.2) 251 0 h from Fig. 5.1.3.4.2.1 and 251 2 h from Fig. 5.1.3.4.2.2 due to all results being undetermined. Likewise 251 2 h from Fig. 5.1.3.4.2.2, despite showing results for 3 repeats, was also discounted due to the irregularities mentioned in sections 5.1.3.4.1 & 5.2.3.4.1.

For both runs expression of *CBF* in sample 232 showed a general trend of decreasing then gradually rising and reaching basal levels of expression between 8 and 14 hours then increasing above the basal 0 h reading from 14 h.

The complete lack of a 0 h result for sample 251 in the first run and only 1 example in the second run made comparisons with its 0 h timepoint difficult. However, the general trend across both runs showed an increase from 5 to 8 h which rapidly dropped back down by 14 hours and continuing to drop by 24 hours.

Although based on only one sample for 0 h (for sample 251), it appears that sample 232 had a higher basal expression level (at 0 h) of *CBF* with sample 251 only showing 0.17x the level of expression of 232 at 0 h (Fig. 5.1.3.4.2.2). It is not known if sample 251 would also show a decrease in *CBF* expression prior to an increase, however its maximal expression is a greater total level than sample 232, also given the possible lower basal *CBF* expression level of sample 251 the fold increase is much greater at 17.7x vs 2.8x (Fig. 5.1.3.4.2.2).

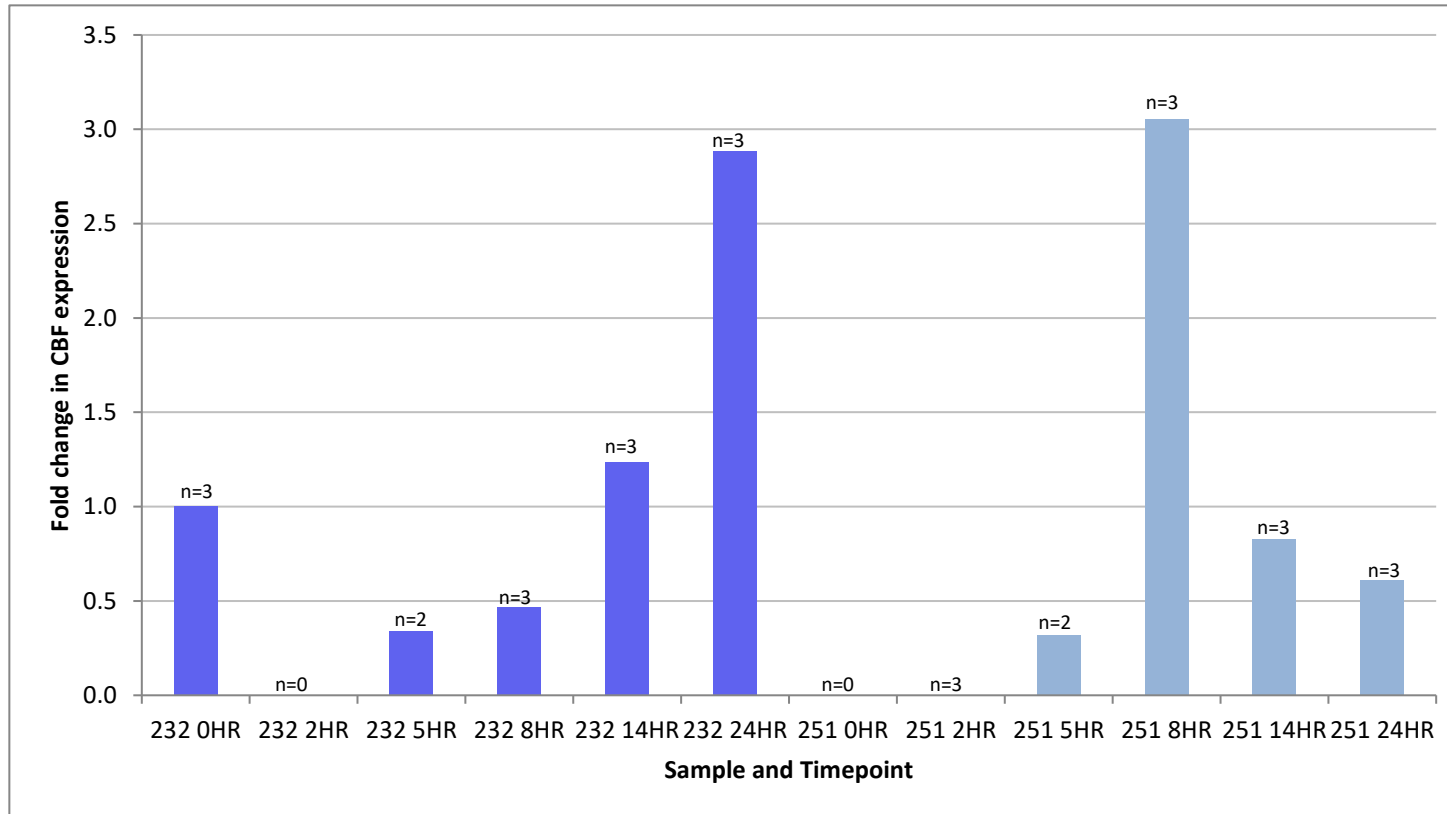

Figure 5.1.3.4.2.1. Showing change in *CBF* expression in response to chilling at 5 °C (see section 2.3.1), 0 h sampled immediately before chilling at 16 °C. Two *Empetrum nigrum* plants were used; 232 (Ben Macdui, Cairngorms, Scotland 1100m altitude) and 251 (Dunkery Beacon, Exmoor, England 476m altitude). 232 0 h sample set to an arbitrary value of 1. Bars show the mean of 3 technical repeats, however in some cases 1 or more result was undetermined so stats were not applied. n=x indicates number of technical repeats that were used in the calculation of the mean of the corresponding bar (i.e. were not undetermined). For timepoints 232 2 h and 251 0 h all results were undetermined.

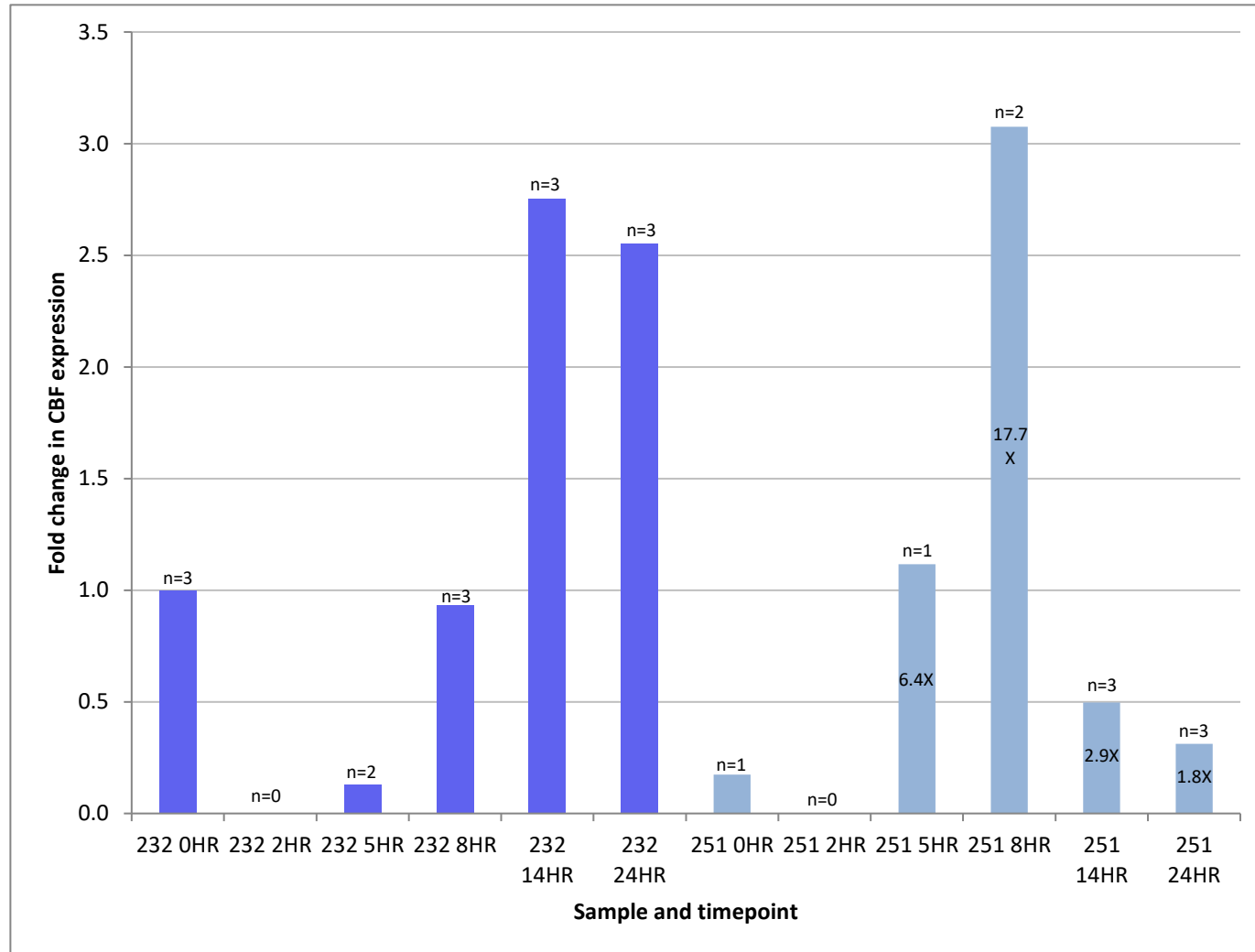

Figure 5.1.3.4.2.2. Showing change in CBF expression in response to chilling at 5 °C (see section 2.3.1), 0 h sampled immediately before chilling at 16 °C. Two *Empetrum nigrum* plants were used; 232 (Ben Macdui, Cairngorms, Scotland 1100m altitude) and 251 (Dunkery Beacon, Exmoor, England 476m altitude). 232 0 h sample set to an arbitrary value of 1. Bars show the mean of 3 technical repeats, however in some cases 1 or more result was undetermined so stats were not applied. n=x indicates number of technical repeats that were used in the calculation of the mean of the corresponding bar (i.e. were not undetermined). For timepoints 232 2 h and 251 2 h all results were undetermined. Numbers on bars from sample 251 show fold change from the 251 0 h timepoint.

5.1.4 Changes in Chlorophyll Content Of *Empetrum nigrum* and *Calluna vulgaris* in Response to Freezing

The freezing shocks of -20 °C and -80 °C cause an apparent reduction in chlorophyll content (of chlorophyll a, b and total chlorophyll) relative to the 16 °C treated samples in *Calluna vulgaris* sample 208 (Fig. 5.1.4.1). However, a significant difference ($p < 0.05$, as assessed by a 1-way ANOVA followed by Tukey's post hoc test) was only seen between the fresh cut 16 °C sample and -20 °C treated sample for chlorophyll a, b and total chlorophyll and between the fresh cut 16 °C sample and -80 °C treated sample for chlorophyll a. There was, however, no significant ($P < 0.05$) difference between either the fresh cut tissue and the 102 hours at 16 °C tissue, nor any significant ($P < 0.05$) difference between the -20 °C or -80 °C treatments for chlorophyll a, b or total chlorophyll. There is also no significant ($P < 0.05$) difference between the 102 hour 16 °C cut tissue and the -20 °C and -80 °C treatments for chlorophyll a and b and total chlorophyll content.

A different trend, relative to that seen for *Calluna vulgaris* sample 208, was seen for *Empetrum nigrum* sample 232 (fig. 5.1.4.1.) For chlorophyll a, b and total chlorophyll; the 102 hours at 16 °C tissue had a significant ($p < 0.05$) (Chlorophyll b: 102 hours at 16 °C vs -80 °C) or highly significant ($P < 0.01$) (all other samples) greater chlorophyll content than the fresh cut tissue or freezing shocked tissue. There was also a significantly ($P < 0.05$) greater chlorophyll a content in the -80 °C treated tissue relative to both the -20 °C and fresh cut 16 °C treatments, but this is not seen for chlorophyll b or total chlorophyll. There was no significant difference between fresh cut tissue and the -20 °C treatment for any chlorophyll content.

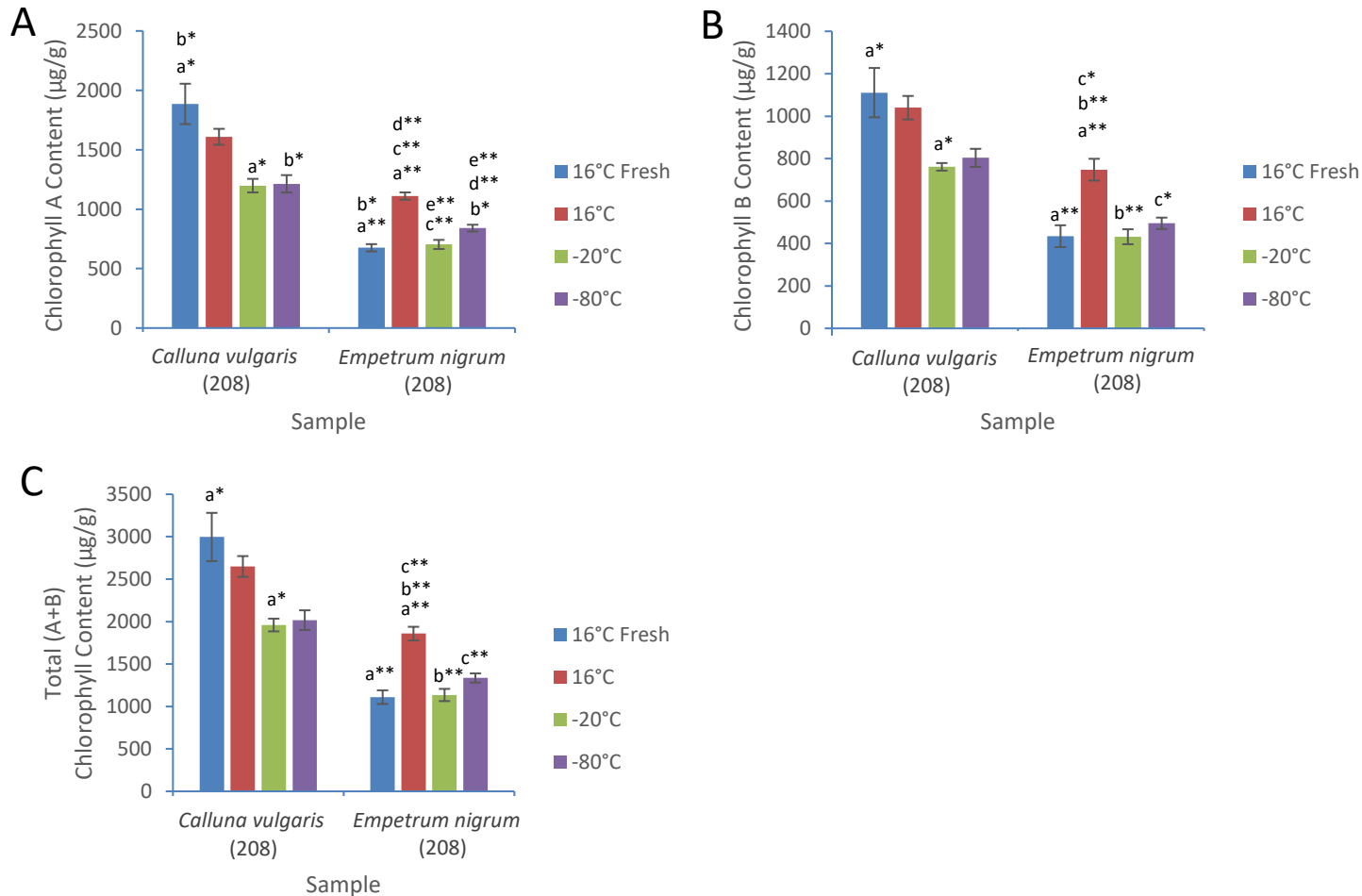

Figure 5.1.4.1 showing μg of chlorophyll A (A), B (B) and Total A+B (C) per g tissue from two living plants of *Calluna vulgaris* (208) and *Empetrum nigrum* (232) from cuttings collected from Creag Dubh and Ben Macdui, Cairngorms, Scotland, UK respectively (see table 2.1.1.1) after four different treatments. 16°C Fresh - Tissue collected from the plant at the same time as the other samples and immediately frozen in liquid nitrogen and stored at -80°C prior to extraction, 16°C – clipped tissue spent 102 hours at 16°C prior to extraction, -20°C – clipped tissue spent 24 hours at -20°C and 78 hours at 16°C prior to extraction, -80°C - clipped tissue spent 24 hours at -80°C and 78 hours at 16°C prior to extraction. Error bars show standard error of the mean ($n=2$ for *Calluna vulgaris* 208 16°C and $n=3$ for all other samples). Letters above bars indicate a significant difference (1 way ANOVA and post hoc Tukey's test) between that bar and the bar with the matching letter for the same species and chlorophyll type. * = $p < 0.05$ ** = $p < 0.01$.

5.1.5 The Association of the Environmental Origin of the Parent Donor Plant with the Morphology of Common Garden Grown Cuttings of *Empetrum nigrum* and *Calluna vulgaris*

5.1.5.1 *Empetrum nigrum*

Empetrum nigrum had a highly significant ($p < 0.01$) strong negative correlation (-0.8 coefficient) between compactness and longitude (Table 5.1.5.3.1 & Fig. 5.1.5.3.3) indicating that the further west that the parent donor plant came from the greater the likelihood that the sample would be compact. There was also a highly significant ($P < 0.01$) positive (0.5) correlation between compactness and latitude (Table 5.1.5.3.1 & Fig. 5.1.5.3.3.) indicating that the further north the parent donor plant came from the greater the likelihood that the sample would be compact. Likewise, there was a highly significant ($P < 0.01$) strong positive (0.7) correlation between compactness and altitude (Table 5.1.5.3.1 & Fig. 5.1.5.3.3.) indicating that the higher the altitude that the parent donor plant came from the more compact the sample was likely to be. The one sample from Galloway: Portpatrick appears as an outlier in both the longitude and compactness correlation and the altitude and compactness correlation (Fig. 5.1.5.3.3).

The correlation tests checking for sampling location bias in *Empetrum nigrum* indicated no association between latitude and altitude (Table 5.1.5.3.1 & Fig. 5.1.5.3.4.). However, some areas have a larger range of altitudes than others (which is unsurprising given that some areas of the UK are more mountainous than others). There was a highly significant ($P < 0.01$) strong negative correlation (-0.7) between longitude and altitude (Table 5.1.5.3.1 & Fig. 5.1.5.3.4.) indicating that samples that came from the greatest altitude were also the most westerly. The Galloway: Portpatrick sample was, again, a clear outlier in this case, being the most westerly and the lowest altitude (Fig. 5.1.5.3.4). There was

also a highly significant ($p < 0.01$) negative correlation (-0.4) between longitude and latitude, indicating that the more northerly the site the greater the likelihood that it was more westerly (Table 5.1.5.3.1 & Fig. 5.1.5.3.4).

5.1.5.2 *Calluna vulgaris*

For *Calluna vulgaris* visually the correlations appeared less strong than those seen for *Empetrum nigrum* (Fig. 5.1.5.3.5 & Fig. 5.1.5.3.3). However, *Calluna vulgaris* had a greater number of samples ($n=68$ vs $n=37$ for *Empetrum nigrum*) increasing the robustness of the Spearman's rank tests. There was a highly significant ($P < 0.01$) negative correlation (-0.4) between compactness and longitude (Fig. 5.1.5.3.5 & Table 5.1.5.3.1) indicating, as with *Empetrum nigrum*, that the further west that the parent donor plant came from the greater the likelihood that the sample would be compact. This correlation (-0.4) was weaker than seen in *Empetrum nigrum* samples (-0.8) (Table 5.1.5.3.1). The Yorkshire samples (further east) seem to be the predominant cause of this weakened trend with several very compact individuals (Fig. 5.1.5.3.5). There was a highly significant ($P < 0.01$) positive (0.5) correlation between compactness and latitude (Fig. 5.1.5.3.5 & Table 5.1.5.3.1) indicating that the further north the parent donor plant came from the greater the likelihood that the sample would be compact. This was identical with the same rank coefficient (0.5) to the pattern seen in *Empetrum nigrum* (Table 5.1.5.3.1). However, there is a greater range in compactness at each latitude in *Calluna vulgaris* (Fig. 5.1.5.3.5 & Fig. 5.1.5.3.3). There was a highly significant ($P < 0.01$) negative correlation (-0.4) between altitude and compactness (Fig. 5.1.5.3.5 & Table 5.1.5.3.1) indicating that there is a greater probability of more compact plants from lower altitudes. This is the opposite of what was seen for *Empetrum nigrum* which had a strong positive correlation (0.7) (Fig. 5.1.5.3.5 & Fig. 5.1.5.3.3 & Table 5.1.5.3.1.)

The correlation tests checking for sampling location bias showed no significant trend between latitude and altitude as with *Empetrum nigrum* (Table 5.1.5.3.1 & Fig. 5.1.5.3.6). There was also no significant correlation between longitude and altitude (Table 5.1.5.3.1 & Fig. 5.1.5.3.6), unlike *Empetrum nigrum* which had a strong negative correlation (Table 5.1.5.3.1). However, as with *Empetrum nigrum*, there was a highly significant ($P < 0.01$) negative correlation (-0.5) between longitude and latitude (Table 5.1.5.3.1 & Fig. 5.1.5.3.6) again, indicating that the more northerly the site the greater the likelihood that it was further west.

Table 5.1.5.3.1. Spearman's coefficients and p-values comparing correlation of compactness with longitude, latitude and altitude and location parameters with one another (longitude, latitude and altitude).

	<i>Empetrum nigrum</i>			<i>Calluna vulgaris</i>		
	Spearman's Rank Coefficient	p value	Significance: *= $P \leq 0.05$ **= $P \leq 0.01$ ***= $P \leq 0.001$	Spearman's Rank Coefficient	p value	Significance: *= $P \leq 0.05$ **= $P \leq 0.01$ ***= $P \leq 0.001$
Compactness & Longitude	-0.756771	5.99×10^{-8}	***	-0.4357726	2.04×10^{-4}	***
Compactness & Latitude	0.4805234	2.61×10^{-3}	**	0.4800531	3.43×10^{-5}	***
Compactness & Altitude	0.6875309	2.59×10^{-6}	***	-0.3655773	2.17×10^{-3}	**
Latitude & Altitude	0.2202466	0.19		-0.1410738	0.25	
Longitude & Altitude	-0.679706	6.88×10^{-6}	***	0.2221947	0.069	
Longitude & Latitude	-0.4397819	6.91×10^{-3}	**	-0.4670459	5.94×10^{-5}	***

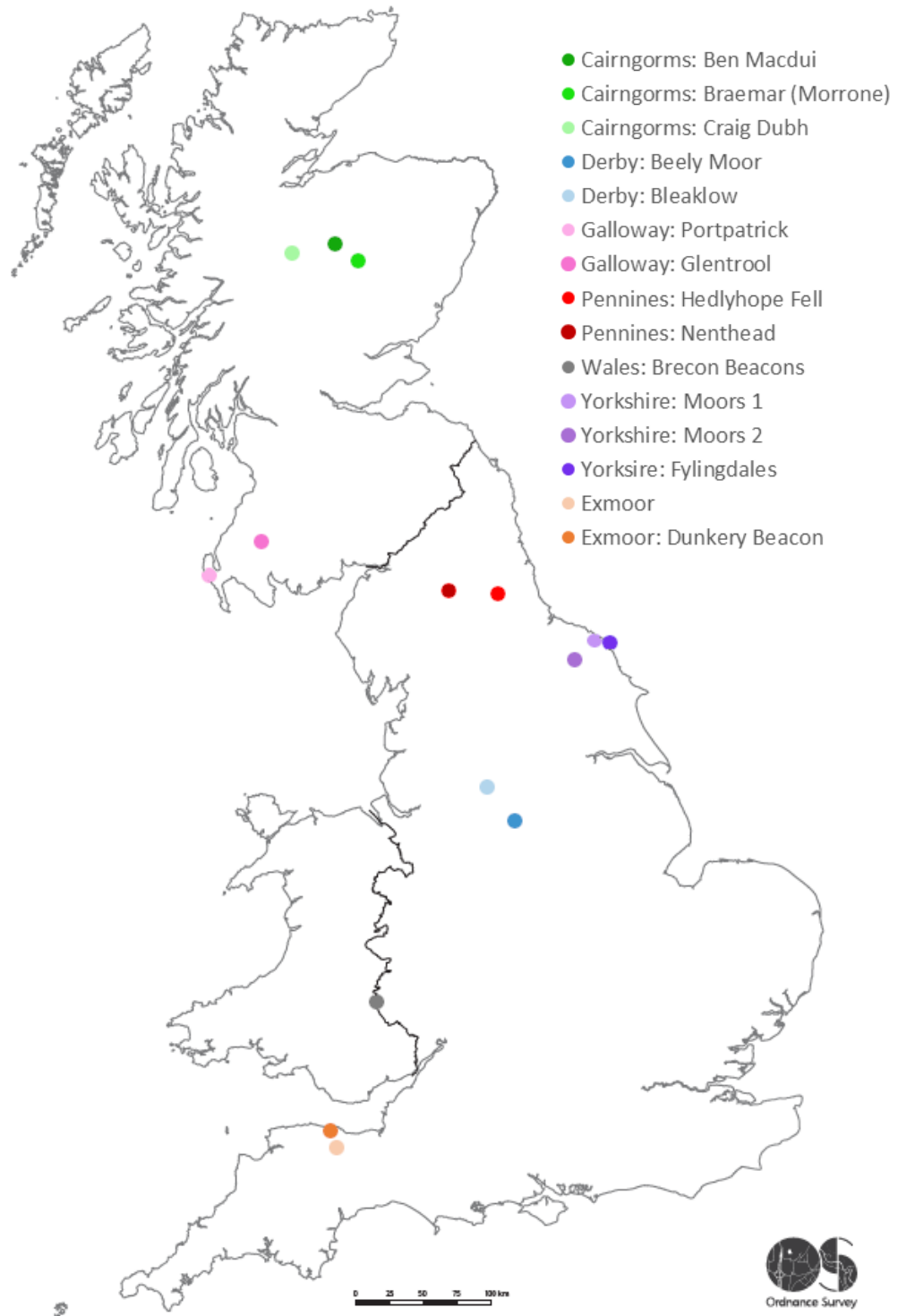

Figure 5.1.3.2. Depicting locations of parent donor plants from which cuttings were collected and grown on. Cairngorms (greens) consisting of: Ben Macdui (Sites 59, 61-63, 68 & 70 table 2.1.5), Braemar (Sites 44-46, 50 & 52 table 2.1.5) and Craig Dubh (Sites 53-57 table 2.1.5). Derby (blues) consisting of: Beely Moor (Sites 144-153 table 2.1.5) and Bleaklow (Sites 154-161 table 2.1.5). Galloway (pinks) consisting of: Portpatrick (Sites 89-99 table 2.1.5) and Glentool (Sites 100-104, 106 table 2.1.5). Pennines (reds) consisting of: Hedlyhope Fell (Sites 40-42 table 2.1.5) and Nenthead (Site 43 table 2.1.5). Wales (grey) consisting of Brecon Beacons (Sites 132-139 & 143 table 2.1.5). Yorkshire (purple) consisting of: Moors 1 (Sites 111, 113 & 114 table 2.1.5), Moors 2 (Sites 115-126 table 2.1.5) and Fylingdales (Sites 107-110 table 2.1.5). Exmoor (oranges) consisting of: Exmoor (Sites 71 & 73 table 2.1.5) and Dunkery Beacon (Sites 78-81 & 83-86 table 2.1.5).

Outline map: Contains OS data © Crown copyright and database right 2018.

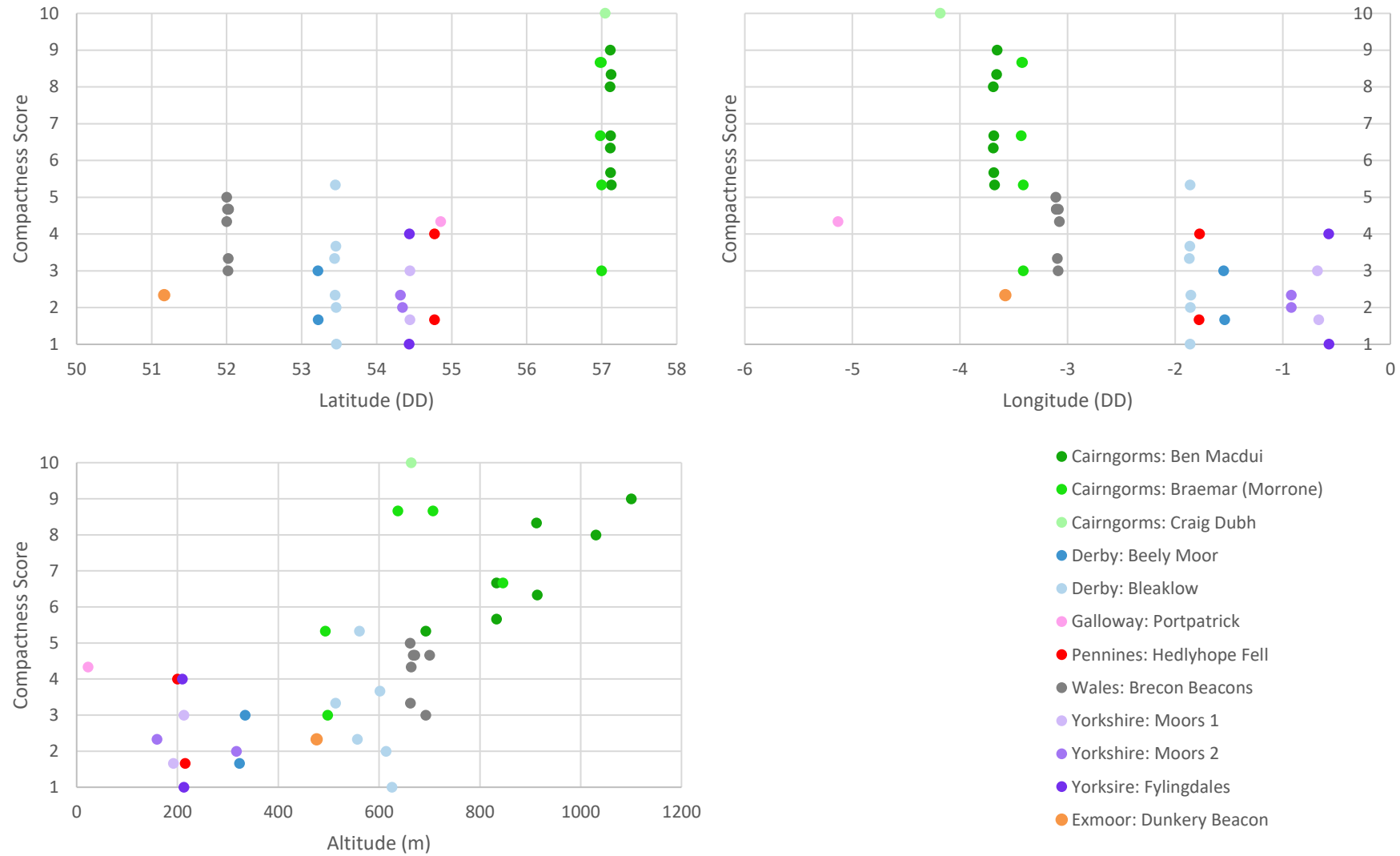

Figure 5.1.5.3.3. Average ($n=3$) observed compactness of common garden grown *Empetrum nigrum* plants grown from cuttings taken from wild plants from various sites across the UK vs. location (Degree Decimal (DD) Latitude, Longitude and Altitude (m)) of parent donor plant. Compactness ranges from a score of 1 for very leggy samples with very little/no branching, long stems, widely spaced leaves and thin stems to 10 for highly compact samples with frequent branching, short branches, closely bunched leaves and thick stems.

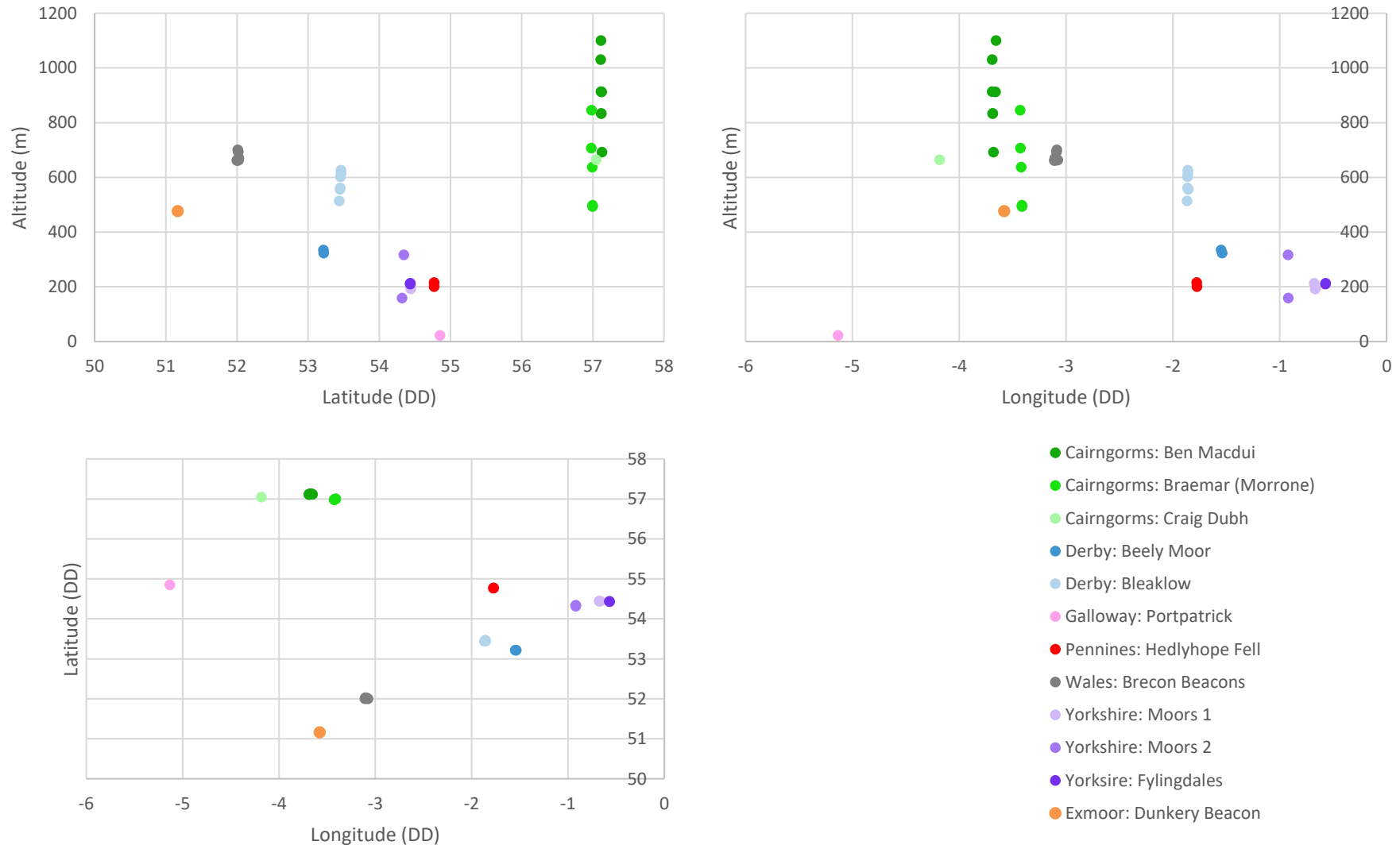

Figure 5.1.5.3.4. Location distribution data for parent donor plant of common garden grown cuttings of *Empetrum nigrum* used for scoring compactness. Each of the three factors (Degree Decimal (DD) Latitude, Longitude and Altitude (m)) are plotted against one another to check for location bias based correlations.

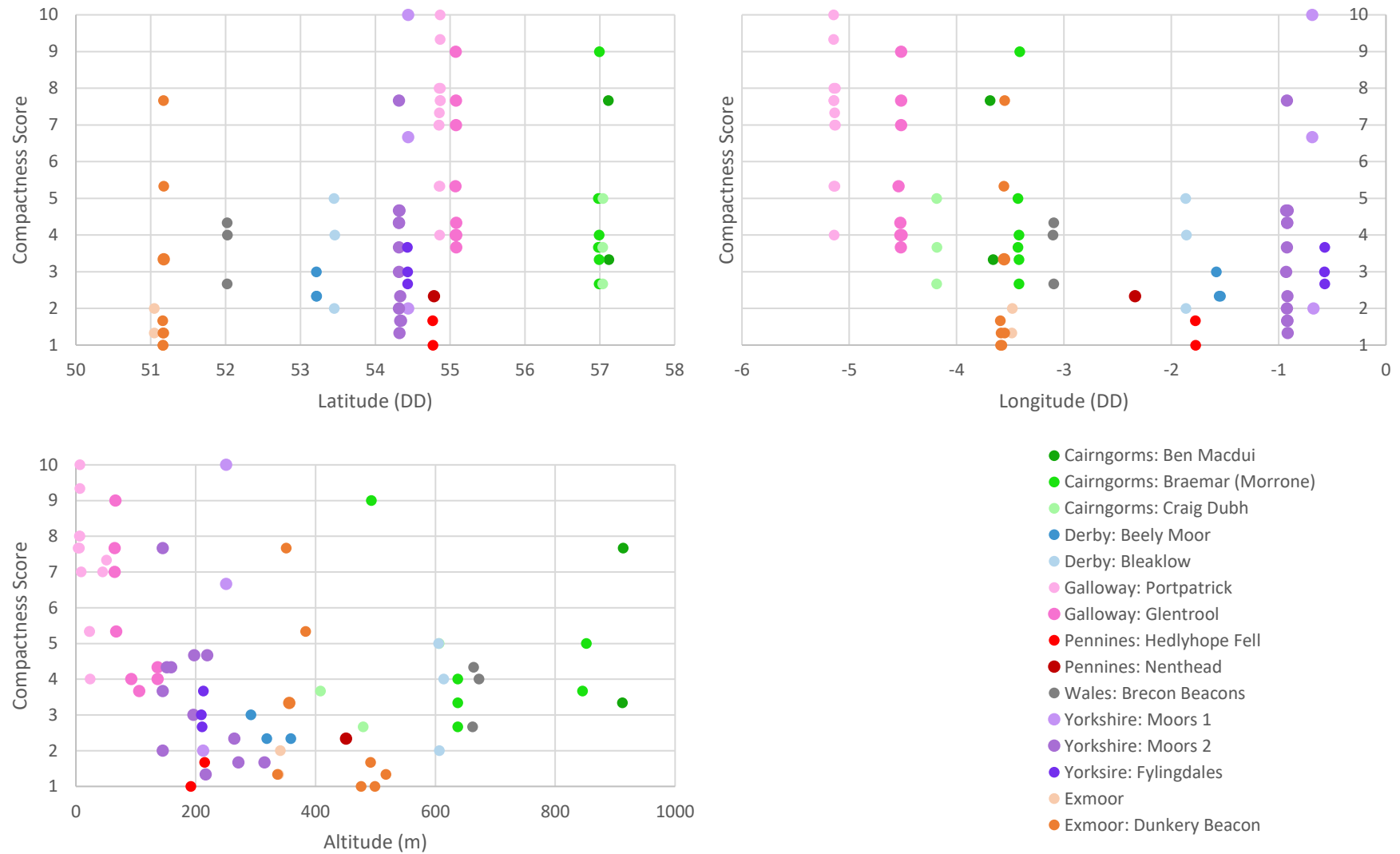

Figure 5.1.5.3.5. Average ($n=3$) observed compactness of common garden grown *Calluna vulgaris* plants grown from cuttings taken from wild plants from various sites across the UK vs. location (Degree Decimal (DD) Latitude, Longitude and Altitude (m)) of parent donor plant. Compactness ranges from a score of 1 for very leggy samples with very little/no branching, long stems, widely spaced leaves and thin stems to 10 for highly compact samples with frequent branching, short branches, closely bunched leaves and thick stems.

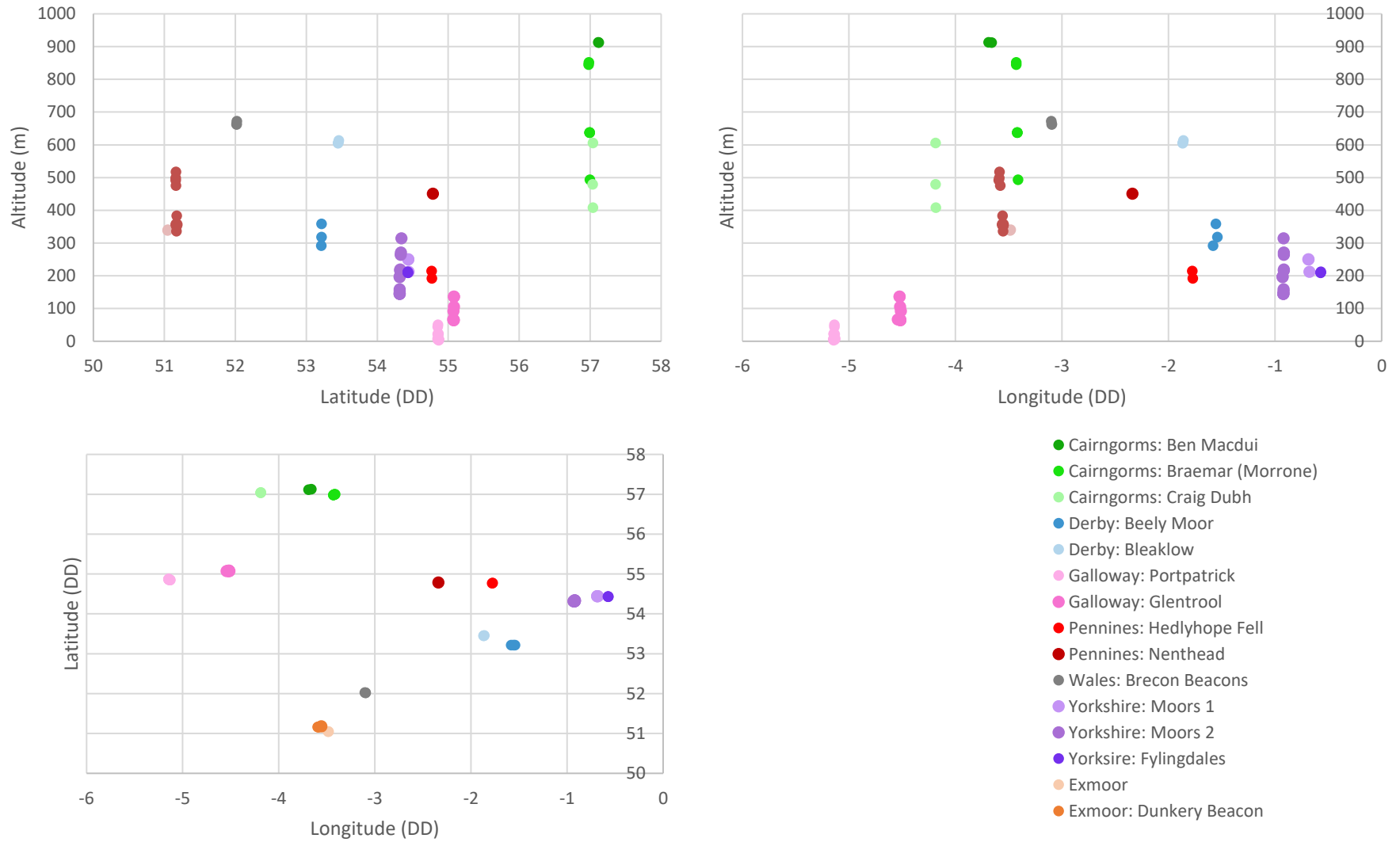

Figure 5.1.5.3.6. Location distribution data for parent donor plant of common garden grown cuttings of *Calluna vulgaris* used for scoring compactness. Each of the three factors (Degree Decimal (DD) Latitude, Longitude and Altitude (m)) are plotted against one another to check for location bias based correlations.

5.2 Discussion

5.2.1 Potential Model Plants

Attempts at growing model plants from seed were unsuccessful; growth and flowering was too slow to be of productive use as a model plant in the timescale of the PhD. Therefore, further exploration of this avenue was discontinued. However, of the species studied *Dryas octopetala* showed the greatest potential, growing well from seed and flowering after 2 years. It could thus be further explored as a potential species of interest for the establishment of a model plant from high altitude and northern distribution.

Calluna vulgaris grew well from cuttings and flowered readily (continuously under ideal conditions (pers. obs)), which resulted in seed set and easy growth from this seed. Although not displaying as high an altitudinal or latitudinal distribution as the original model species candidates, *Calluna vulgaris* may, however, prove a good target for establishment of a model moorland shrub species. *Calluna vulgaris* specifically may be of interest for further study, especially given its dominant distribution in moorland habitats and commercial value for moorland game. That *MATK* sequences could be isolated from *Calluna vulgaris* despite the inability to isolate *CBF* indicates that lack of DNA purity is not the cause of this failed *CBF* isolation and therefore *Calluna vulgaris* could be a target for full genome sequencing and possible establishment as a model species.

5.2.2 The *CBF* sequence of *Empetrum nigrum*

The *Empetrum nigrum* samples sequenced came from a wide range of environments and altitudes (Table. 2.1.5a-x) which represent an array of different maximum freezing temperatures and likelihood of freezing events (Met-Office, 1981-2010). It was therefore predicted that there might be differences in maximal freezing tolerance and onset of

acclimation in *Empetrum nigrum* plants which experience different maxima and timing of freezing events. One possible mechanism of any difference could be via the transcription factor CBF which is involved in acclimation and acquisition of freezing tolerance (Jaglo-Ottosen et al., 1998, Gilmour et al., 1998, Thomashow et al., 2001). Changes to the protein structure of the CBF sequence could alter protein stability, binding and/or activation of *COR* genes (the targets of CBF) altering freezing tolerance. Once compared there were, however, very few differences between the nucleotide, and hence translated, sequences of CBF in *Empetrum nigrum* from a wide variety of environments (Fig. 5.1.2.2a-b).

The key differences (those seen in more than one sequence) were at amino acid 109 (P or L) and 148 (M or T, one sequence had K). The first difference falls within the AP2 region, the latter within the COOH terminus. The COOH terminus has a high degree of functional redundancy and even large changes in this sequence do not affect binding or activity (Wang et al., 2005). It is therefore unlikely that the variance at site 148 has any effect on the functionality of the CBF. The mutation in the AP2 region may affect CBF binding as key amino acids for binding have been identified in the AP2 region previously (Sakuma et al., 2002) however this position is not one that has been previously identified. There was no link between location and the presence of one amino acid at this position over another and numerous samples were degenerate for this amino acid at that base (i.e. had a degenerate codon in the nucleotide sequence, which resulted in P and L or M and T from the same sample, seen as X in the translated sequence (Fig. 5.1.2.2a-b)). Therefore, this suggests that these are different alleles which are both present throughout the species, with some homozygous and heterozygous individuals existing in the populations studied, and is therefore unlikely to alter CBF binding. That 148(M) is always associated with 109 (P), but not the other-way-around, suggests that the M substitution arose from a sequence with 109 (P).

Given the high overall conservation and the ubiquity of the few changes seen, it does not appear that changes to the CBF sequence have occurred in response to differing environments. It is possible that there is no variance in freezing tolerance in *Empetrum nigrum* between different environments, all reaching maximal freezing tolerance once acclimated. However, given that *CBF* expression has a negative effect upon growth (Achard et al., 2008, Suo et al., 2012, Liu et al., 1998, Gilmour et al., 2000, Pino et al., 2007), unless a bypass for this growth retardation has evolved, it seems unlikely that all plants from differing environments, and therefore differing freezing risk, would respond in the same manner to cold events (i.e. if a plant which frequently experiences cold without freezing activates CBF, as readily as one which does not, it will suffer with frequently reduced growth). It is possible that other *CBF* genes are involved; Only one gene was isolated here but many plants have more than one *CBF* gene (Medina et al., 1999, Xiong and Fei, 2006, Skinner et al., 2005, Xiao et al., 2008, Miller et al., 2006). Whilst it is also possible that the *COR* genes (targets of CBF) have changed to alter freezing tolerance, this is unlikely due to the large number of *COR* genes and their individual effects upon freezing tolerance. For example, constitutive overexpression of *COR15A* increases freezing tolerance of chloroplasts and protoplasts in *A. thaliana* (Artus et al., 1996). However this is at the expense of reduced survival at higher (however still freezing) temperatures (Artus et al., 1996). Whereas, expression of multiple *COR* genes via overexpression of *CBF1* increases freezing tolerance to a greater degree than *COR15A* alone (Jaglo-Ottosen et al., 1998). Therefore, changes to *COR* genes would have to occur over multiple *COR* genes to affect all aspects of increased freezing tolerance, and control of this tolerance would still be required (provided by *CBF*). Therefore, it seems more likely CBF would change. However, given that there is no change to CBF protein itself it is more likely that the control of CBF has altered. This could be via changes in the promoter sequence (Zarka et al., 2003) or upstream regulators of CBF such as ICE1, a

positive transcription factor that regulates CBF transcription (Chinnusamy et al., 2003). Therefore, the individual freezing tolerances of plants from different locations were investigated, to identify if different freezing tolerances are associated with different locations, alongside *CBF* expression studies to identify any changes in extent and timing of *CBF* expression responses to cold based upon the location of origin of the parent plant (of common garden grown cutting plants).

5.2.3 *CBF* expression in *Empetrum nigrum*

5.2.3.1 Suitability of Primers Designed for qPCR

No previous research utilising qPCR has been reported on *Empetrum nigrum*. Therefore, several methodological steps (optimised for *Arabidopsis thaliana*) had to be re-optimised.

qPCR requires primers which are specific to the gene of interest and, ideally, perfectly match the sequence. Therefore, the sequence data for *CBF* gathered in this project for *Empetrum nigrum* was used for primer design. There is no full genome data for *Empetrum nigrum* and therefore the possibility of priming elsewhere in the genome could not be ascertained in any other way than performing PCR itself. As no previous research utilising qPCR has been reported for *Empetrum nigrum*, there were no known and tested primers for housekeeping genes (i.e. genes whose expression remains constant to normalise the change in expression of the test gene against), nor had any likely housekeeping gene candidates been previously identified. After searching the NCBI database (NCBI, 2018) for sequenced *Empetrum nigrum* genes which could be of use as housekeeping genes, only *RPB2I* was identified as a potential candidate. *RPB2I* was selected as it was the only nuclear gene sequence found covering an exon that was not ribosomal RNA or likely to respond to stress. Two pairs of primers for each gene (*CBF* and *RPB2I*) were then designed and tested. Upon testing, primers *CBF*(2) were chosen over *CBF*(1) due to

having a T_M closer to the housekeeping genes, less variation in CT values between repeats and the amplification from the genomic control (NRT) relative to the cDNA being lower than seen for *CBF(1)*. The T_M value is the temperature at which 50 % of the primer DNA disassociates; therefore having similar T_M values is advantageous. The CT value is the number of cycles taken to reach a set amount of amplification product; less variation between matching reactions indicates more reliable reactions, although this variation could be due to pipetting error. The higher amplification in the genomic control may indicate that *CBF(1)* was priming elsewhere in the genome. *RPB2Ib* was chosen over *RPB2Ia* because primers *RPB2Ia* did not amplify from cDNA and had highly variable T_M values indicating a failure to bind the site of interest. This could possibly be due to non-specific binding at multiple sites within the genome, and/or the formation of primer dimers and/or that the sequence of *RPB2I* in these collected samples was not the same as for the sample used. The *Empetrum nigrum* specimen from which *RPB2I* was amplified was from Washington, USA (Goetsch et al., 2005) whereas the test samples used were from across the UK. Further it is also not stated which subspecies of *Empetrum nigrum* was used by Goetsch et al., (2005) to obtain the *RPB2I* gene in the NCBI database. It is therefore possible that the UK specimens have a different *RPB2I* gene sequence. However, given that the MATK sequences for samples of *Empetrum nigrum* from across the world (including north America and the UK) and from alleged different subspecies are identical (the existence of subspecies is also in question: see section: 5.2.6) and that the *RPB2I* exons encode a vital protein (RNA polymerase subunit 2) the probability of differing *RPB2I* exons is greatly reduced. However, this inability to amplify meant that *RPB2a* primers could not be used for amplification of the housekeeping gene. There was higher amplification from the genomic control than from the cDNA with primers *RPB2Ib* which indicated that the primers were priming elsewhere in the genome. However, since no other potential housekeeping genes were sequenced at the time of study and no other

viable primer design sites were present in the *RPB2I* sequence primers *RPB2Ib* were used. In all cases the genomic control (NRT: RNA with no reverse transcriptase added when making cDNA – so no cDNA is formed) had lower CT values (i.e. a set amount of product reached with fewer cycles) than the cDNA samples. Similar CT values would be expected if there was preferential binding to the genomic DNA (as there would also be genomic contamination in the cDNA test – as it was amplified from the same RNA as the genomic tests). It therefore seemed possible that in the absence of high levels of target sequence (genomic control) primers were binding to less specific sites which would not occur, or be greatly reduced, in the presence of appropriate target (cDNA) and therefore these primers were taken forward for use.

5.2.3.2 Optimal dilution of *Empetrum nigrum* cDNA for qPCR

A 1:20 dilution of cDNA is the standard used in the Knight lab for qPCR on *Arabidopsis thaliana* cDNA. However, due to using a species not previously studied via qPCR (*Empetrum nigrum*) a variety of dilutions were tested to find the optimum dilution and test for the presence of inhibitors. The steady increase seen in CT value as starting material is diluted is as expected (since less target sequence, the limiting factor, means a longer time is taken to reach a certain amount of product). The regularity of this increase indicates that the RNA is unlikely to contain inhibitors which would otherwise show low amplification at high concentrations (as the concentration of inhibitor would be higher) and greater amplification at lower concentrations, as the inhibitor is diluted. A 1:50 dilution was selected as optimum due to a reasonable amplification rate, limited variation between results (i.e. small error bars) and a larger dilution therefore maximising usage of cDNA and hence RNA (which was vital due to low RNA yields).

5.2.3.3 The Effect of Chilling upon *CBF* Expression in *Empetrum nigrum*

An apparent decrease in *CBF* expression was seen upon subjecting tissue to chilling in ice for 3 h. This is contrary to what is typically seen for the *CBF* response in *Arabidopsis thaliana* (Gilmour et al., 1998, Medina et al., 1999). Assuming that the decrease seen is real and not an artefact, it is possible that this *CBF* gene is a negative regulator of other *CBF* genes and therefore downregulated in response to cold to allow for rapid increase in activation of *COR* genes by other *CBF* genes. Negative regulators of other *CBF* genes have been proposed in *Arabidopsis thaliana*, namely that *CBF2* is a negative regulator of *CBF1* and 3 (Novillo et al., 2004). It is unknown how many *CBF* genes are present in *Empetrum nigrum*; only one gene was isolated using the method described in sections 2.5-2.8. However, this does not exclude the possibility of multiple *CBF* genes in *Empetrum nigrum*, merely a failure to isolate them. There are other possible causes of this apparent reduction in expression. It is possible that this apparent decrease could be due to the tissue being cut from the plant for 3 hours whilst submerged in ice whereas the ambient sample was taken straight from the plant and submerged in liquid nitrogen. Removal from the plant could result in changes in the priority of expression, preparation for potential freezing being of lesser importance than severance from roots. It is known that *Empetrum nigrum* roots easily from cuttings (section 2.2.2.2), therefore it is possible that priority RNA expression is given to wounding responses and preparing for tissue regeneration and rooting. Also, whilst regulation of *RPB2* (the gene chosen as a housekeeping gene for *Empetrum nigrum*) does not change in response to cold in *Arabidopsis thaliana* (Kilian et al., 2007, Winter et al., 2007, TAIR, 2018), it should be noted that expression of *RPB2* is slightly upregulated in response to wounding in *A. thaliana* (Kilian et al., 2007, Winter et al., 2007, TAIR, 2018). *A. thaliana* has a very different growth habit and lifecycle to *Empetrum nigrum* and does not root easily from cuttings (a form of wounding), unlike *E. nigrum*. Therefore, the degree of this change in

expression of *RPB2* may be different in *E. nigrum* relative to *A. thaliana*. If expression of *RPB2I* is upregulated slightly or to an even greater degree than seen in *Arabidopsis thaliana* in response to wounding this could result in an apparent decrease in *CBF* expression, due to an increase in the background reading which is assumed to remain constant. Another possibility, or potentially compounding factor, is that in response to cold there could be an increase in metabolites that act as inhibitors to qPCR in the plant, such as phenolics and polysaccharides (Schrader et al., 2012), whilst inhibitors were not a problem for RNA from fresh tissue, likely having been successfully removed in the extraction steps, they could overload the removal process at high concentrations resulting in inhibitors in the extracted RNA. This inhibition would increase the apparent CT value, however the baseline housekeeping gene would also have an increase CT value as a result of inhibition, therefore inhibition is unlikely to be the sole cause.

Another possibility for the apparent decrease is the effect of circadian rhythm. The fresh sample was placed immediately into liquid nitrogen whereas the sample exposed to the ice treatment was cut at the same time then spent 3 hours on ice. The basal level of *CBFs* and the level to which *CBFs* can be induced is known to fluctuate with the circadian clock in *Arabidopsis thaliana* (Fowler et al., 2005); the three hour difference could therefore result in different basal levels. For example, the fresh tissue could have been taken at a time where there is a higher basal *CBF* level, therefore *CBF* may be induced in the 3hour iced sample relative to the basal level 3 h later (which may be significantly lower). This seems unlikely however as it would be expected that ice should still induce *CBF* to a higher level than even the highest basal level. Another possibility is that 3 hours is insufficient time for *CBF* to be induced, either due to a general slow response or being less responsive for the time of day. For *Arabidopsis thaliana* *CBF* transcripts increase rapidly within 15 mins and continue to do so for up to the next 2 h, although levels then drop (yet remain higher than plants not exposed to cold) (Gilmour et al., 1998, Medina et

al., 1999), it therefore seems likely that an increase would be seen in *Empetrum nigrum* after 3 hours. However, it is possible, that due to *Empetrum nigrum* coming from a colder natural environment, where cold periods are frequent, combined with a lower basal freezing tolerance prior to acclimation (approx.. -15 °C) (Yamori et al., 2005) relative to *Arabidopsis thaliana* (-4 °C to -8 °C) (Hannah et al., 2006), that a much slower induction of *CBFs* occurs in *Empetrum nigrum*. This could be because induction of genes involved with acclimation for freezing are not required until temperatures below -15 °C are expected. Cool temperatures are likely frequently experienced and so longer periods of cold may be required to upregulate *CBF*.

In order to investigate the change of expression over time a timecourse was performed with set sampling intervals. The whole plant was also cooled to avoid potential issues caused by prolonged periods separated from the plant.

5.2.3.4 Kinetics of *CBF* Expression in Response to Chilling in *Empetrum nigrum* Between Plants Originating From Different Environments

5.2.3.4.1 Irregular Amplification

Whilst the qPCR amplification plots for the majority of samples and timepoints (Figs.5.1.3.4.1.1 & 5.1.3.4.1.2) display standard amplification patterns, the 2 h timepoint for both sample 232 and 251 exhibit abnormal amplification. This abnormal amplification takes the form of an apparently extremely rapid amplification of both the test gene (*CBF*) and the housekeeping gene (*RPB2I*) in sample 232 and rapid then failed amplification in sample 251 (Figs .5.1.3.4.1.1 & 5.1.3.4.1.2). A dilution error (namely a higher concentration) would result in apparent rapid amplification of both the test and housekeeping gene as seen in sample 232 due to higher initial template. However, this possibility was excluded by re-running the qPCR with a new cDNA dilution of this sample and the same anomaly still occurred (Fig. 5.1.3.4.1.2). Likewise, the re-run also

removed the possibility of contamination at the plate preparation stage (e.g. too much reporter probe), and also a mastermix was always used during preparation of both plates which significantly reduced the likelihood of this situation occurring initially. That abnormal amplification is seen for both samples at the 2 h timepoint and across re-runs, suggests this is due to something that occurred at this timepoint. A high increase in *CBF* would explain the rapid increase in *CBF* read but not the corresponding increase in the housekeeping *RPB2I* gene which should not change in expression. It is possible that *RPB2I* is not a true housekeeping gene and is also being upregulated, although *RPB2* has previously been found to be suitable as a housekeeping gene in parthenogenic fungi (Jacob et al., 2012) and does not respond to cold in *Arabidopsis thaliana* (Kilian et al., 2007, Winter et al., 2007, TAIR, 2018) it does not exclude the possibility that expression does change in *Empetrum nigrum* however the probability is reduced. It is also possible that something else is being upregulated in the genome (alongside *CBF*) which the *RPB2Ib* primers are also priming to. This is supported by the primer tests (see section 5.2.3.1) which indicated the possibility of the *RPB2Ib* primers priming elsewhere in the genome. If expression of this/these other sites to which *RPB2Ib* primers are priming to are upregulated after 2 h this would explain the increase in *RPB2I* expression. It is also possible the plants are not responding to the chilling but to some other environmental factor that may have occurred at the 2 h timepoint. The growth chambers are constantly monitored and no record of an unexpected change in the environment was recorded. However, it is possible that a very brief sudden change would not be recorded due to the infrequency of the sampling by the monitor. The likelihood of this resulting in a change in *RPB2I* expression seems unlikely, given extreme transience of such an event and the general stability of expression *RPB2I* in response to stresses in *A. thaliana* (Kilian et al., 2007, Winter et al., 2007, TAIR, 2018). The abnormal readings could alternatively, or additionally, be the cause of an accumulation of inhibitors such as phenolics or

polysaccharides (Schrader et al., 2012). This is unlikely to be a direct response, however, since inhibitors, inhibit qPCR rather than resulting in an apparent increase. One possibility is that inhibitors, via the inhibition of amplification, are resulting in the promotion of the formation of primer dimers; if the target sequence is sequestered due to inhibitors primer dimers may be more likely to form. SYBR green binds non-specifically to any dsDNA (Giglio et al., 2003, ThermoFisher, 2018b), disassociating upon DNA melting. Therefore, it will bind to primer dimers giving a false fluorescence response, which could explain the apparent rapid increase in product (which is in fact primer dimers) in both the test (*CBF*) and housekeeping (*RPB2I*) genes. Whilst low target sequence could also result in primer dimers it would not explain the apparent increase in *RPB2I* which should remain constant. However, evidence of primer dimers should appear on the dissociation curves (ThermoFisher, 2018a) and this was not seen.

5.2.3.4.2 Kinetics of *CBF* Expression

There was very little amplification of *CBF* in the 0 h timepoint for sample 251 (Exmoor), resulting in several results being undetermined (undetermined samples being those that do not reach the designated amount of product within 40 cycles), those which were not undetermined had a very high CT values. This indicates that either there was some problem with amplification, possibly due to contaminants in the RNA (for example inhibitors such as phenolics or polysaccharides) or that there was very little to no basal level of *CBF* expression in sample 251. The latter possibility is plausible; 16 °C, with light cycles mimicking summer, is not a temperature and season in which a low altitude and southernly Exmoor sample (sample 251: Dunkery Beacon, Exmoor, England 476m altitude) is likely to experience a freezing event (Met-Office, 1981-2010) therefore there may indeed be no or very little basal level of *CBF* expression. Sample 232 however, being from a northernly and high altitude location (Ben Macdui, Cairngorms, Scotland 1100m altitude), would possibly experience freezing events in summer (and was collected from

above snow lie in July) where sudden changes in temperature are likely common. For example on the 30th September 2015 the lower altitude (339m) met-office recording station at Braemar recorded a maximum temperature of 24 °C and a minimum of -1.3 °C (Met-Office, 2016). Therefore sample 231 having a higher basal expression level of *CBF* expression relative to 251 might be to be expected.

Both samples show a pattern of an initial drop in *CBF* expression upon chilling, followed by an increase in expression. In sample 251 (Exmoor) the *CBF* expression drops back down between 8 and 14 h, whereas sample 232 (Cairngorms) does not appear to decrease after 24 hours. *CBF* expression in *Arabidopsis thaliana* starts to increase after ~15 minutes and peaks at around 2 h before dropping back down (Gilmour et al., 1998, Medina et al., 1999). Based on these expression patterns it would appear that the response in *Empetrum nigrum* is much slower peaking at around 14-24 h for the Cairngorms sample (232) and around 8 h for the Exmoor sample (251). It should be noted, however, that it is not known what happens between 15 minutes and the 5 h timepoint and there are still some amplification issues after 5 h (as exemplified by n<3 (Figs. 5.1.3.4.2.1 & 5.3.4.2.2)). As discussed in section 5.2.3.4.1 readings within these timepoints are not reliable due to interference with the qPCR meaning the fluorescence signal cannot be correctly read. It is therefore possible that there is an initial early increase in *CBF* expression which is not seen in these results. Multiple peaks in *CBF* expression has been reported in *Arabidopsis thaliana* in response to chilling, a second peak occurring around 2-3 h (depending on *CBF* gene and plant accession) (McKhann et al., 2008). It is therefore possible that the missing data may cover an initial peak in *CBF* expression and that the observed decrease followed by an increase is a later peak. Assuming, that the apparent slower than *A. thaliana* response is correct this slower response could be due to the higher basal freezing tolerance of *Empetrum nigrum* (approx. -15 °C) (Yamori et al., 2005) over *Arabidopsis thaliana* (-4 °C to -8 °C) (Hannah et al., 2006). The risk due to a further drop

in temperature is therefore of less risk to *Empetrum nigrum* than to *Arabidopsis thaliana*, therefore a slower response allows for assessment of the temperature drop to identify if the new temperature is consistent or merely a fluctuation. This would also explain the apparent slower response in the Cairngorms sample than the Exmoor sample. A prolonged period of 5 °C in Exmoor is more likely to indicate the onset of winter than a prolonged period of 5 °C at high elevation in the Cairngorm mountains where drops to 5 °C would be common even in summer. For example, the lower altitude (339m) Braemar weather station records a minimum close to 5 °C or lower almost every month (Met-Office, 1959-2018), this higher altitude sample (1100m) would therefore regularly experience 5 °C. The Cairngorms sample also has an apparent higher basal level expression on *CBF*. If this is actually the case (see problems discussed earlier) it is possible that, prior to acclimation, it is more freezing tolerant than the Exmoor sample, therefore providing another reason for the lack of requirement to respond as quickly as the Exmoor sample. That the expression of *CBF* in the Cairngorms sample does not drop after 24 h is also interesting and there are several possibilities to explain this. One is that it is a slow and steady response relying on a slower and longer expression of *CBF* to achieve high freezing tolerance rather than an initial high increase in expression of *CBF*, allowing for easy and rapid reversal should the cold period not persist. Another possibility is that because the 24hour timepoint is 2 hours after the lights switch on in the chambers, this would cause a slight warming effect, it is known that *CBF1-3* expression also increases during de-acclimation in *Arabidopsis thaliana* (Zuther et al., 2015), and in warm spells in acclimated overwintering birch (Welling and Palva, 2008). However, the temperature fluctuation would be very minor (a degree or two) so this seems unlikely. Another possibility is that the maintained high *CBF* expression after 24hours is a new basal *CBF* expression level for the Cairngorms sample and this is higher after exposure to cold than the Exmoor sample: Although *CBF* expression decreases after an initial peak

the overall level usually remains higher than before acclimation in *Arabidopsis thaliana* (McKhann et al., 2008) and the degree of increase is dependent on the accession, with more freezing tolerant accessions tending towards a greater increase (McKhann et al., 2008). It has also been shown that a maintained high level of *CBF* is associated with increased freezing tolerance, with a more freezing tolerant winter wheat maintaining a higher *CBF* expression level upon exposure to cold than a less freezing tolerant Spring wheat variety (Kume et al., 2005). Indeed, the winter wheat variety still maintained a high *CBF* transcript level (and still some evidence of still increasing expression) after 63 days in the cold whereas the transcript level for a spring wheat variety started to decrease after 21 days (after a steady increase up to that point) (Kume et al., 2005). This long-term increase *CBF* expression level in wheat varieties was not apparent upon a 24hour scale, with both varieties appearing to decrease in *CBF* expression by 24 hours (Kume et al., 2005). Therefore, it is highly possible that, if studied over a much longer time scale, a different pattern of *CBF* expression may be seen for the *Empetrum nigrum* samples.

Another possible explanation for the apparent expression pattern is that the *CBF* sequenced could be a negative regulator of other *CBFs*. It has been proposed that *CBF2* regulates expression of *CBF1* and 3 in *Arabidopsis thaliana* (Novillo et al., 2004). The Cairngorms sample may have a consistent higher basal level of such a regulator as it would be subject to regular temperature drops which could result in energy loss if constant acclimation and declamation occurred. It would also be important at high altitude and latitude to maximise the growing period therefore continuing to grow at low temperatures whereas this would be of less import to a low altitude and latitude plant where there are more, longer and more optimal growing degree days. The initial apparent decrease in *CBF* expression in both samples could be the removal of the negative regulator in response to the rapid temperature drop, therefore allowing upregulation of the other *CBFs* to cold acclimate. The negative regulating *CBF* then increases to a high level to cease

upregulation of the other *CBFs*. The relatively low altitude and latitude Exmoor sample then reduces expression of this regulator again to continue at the current, new level of acclimation. The high altitude sample, upon sensing no further drop in temperature, may continue with a high level of negative regulation both in preparation for removal of the negative regulation to rapidly increase freezing tolerance and acclimate in response to a further decrease in temperature but also to inhibit dormancy and maintain metabolic and growth activities at the current lower temperature.

Due to high variability in results and amplification issues no reliable conclusions could be drawn from the study. Even between repeats with the same cDNA samples, variation in the pattern was seen indicating high error and amplification issues. Potential causes include the initial RNA isolation step where genomic contamination could be present as indicated in section 5.2.3.1. The RNA could also be contaminated with inhibitors. Although the dilution tests indicated no presence of inhibitors at ambient temperatures it is possible that inhibitors, such as polysaccharides (Schrader et al., 2012) would accumulate in response to *CBF* expression, as seen in *Arabidopsis thaliana* (Cook et al., 2004) and therefore timepoints with higher expression of *CBF* may also have inhibitors present. Primer issues seem the most likely cause (as identified in section 5.2.3.1 and 5.2.3.4.1). It is possible that the housekeeping primers were non-specific and the *CBF* primers may also have been relatively non-specific. However, this specificity issue cannot be addressed by the creation of new primers, as no alternative sequences are known to design the primers to. RNA transcript level could also be assessed via other methods such as RNA Gel-Blot Hybridization Analysis as described in Gilmour et al., (1998) and Fowler et al., (2005), however there is a loss of finer detail using this method rather than qPCR. The ideal solution would be to fully genome sequence *Empetrum nigrum* to identify all potential *CBF* genes and design of specific primers for each. This would overcome the non-specificity issue and would also allow for the analysis of all *CBF*

sequence responses which could aid in the identification of whether the *CBF* assessed in this timecourse was a negative regulator of possible other *CBF* sequences or not. Full genome sequencing would also allow for the identification of multiple potential housekeeping genes which could be further tested, such as via RNAseq, and the optimum (or a selection of several) housekeeping gene(s) could then be used to improve robustness of the data and baseline readings. The possible issues with inhibitors or extremely high transcript levels could also be assessed and addressed by further dilution tests at multiple timepoints. Once the qPCR technical issues were addressed, further biological complications could be assessed. Repeat timecourses could be run to identify what happens at the 2 hour timepoint that is missing from this experiment due to the issues described above. The issue of circadian cycling could be assessed via a timecourse without chilling to assess how the baseline expression of *CBF* cycles throughout the day, which could then be compared to the same timepoints after a chilling event. More frequent earlier timepoints could also be taken to assess early changes in *CBF* expression and if multiple peaks in expression is seen. Later timepoints, over days and weeks exposed to the new cold temperature, could assess if the increased *CBF* expression is truly a new basal level or a slow increase in *CBF* expression response, and comparisons could be made between the length of maintenance and degree of *CBF* expression between plants from different environmental origins. Freezing assays on plants from different locales could also be performed to assess if the basal level of freezing tolerance differs between samples from different locales and if this correlates with the basal *CBF* expression level. More timepoints and/or freezing assays would however require the generation of more tissue, plants would have to be grown on to a larger size or multiple cuttings taken in order to have multiple clone plants to test. The possibility of delayed dormancy in plants which are more prone to cold periods outside of winter such as 232 could also be assessed

by infra-red gas analysis (IRGA) to assess the change in photosynthesis upon chilling relative to plants from warmer climates.

Despite inherent unreliability of results and resultant difficulty in interpretation, the preliminary data does, however, suggest that there may be a difference in regulation and timing of *CBF* expression between plants collected from differing locations. Therefore, further investigation to assess if this is consistently the case and follows a specific pattern and, if so, the mechanism for this difference, is warranted.

5.2.4 The use of Chlorophyll Content to Assess Freezing Tolerance in *Empetrum nigrum* and *Calluna vulgaris*

5.2.4.1 *Calluna vulgaris*

The lack of any significant difference between the chlorophyll content of fresh cut *Calluna vulgaris* tissue and tissue excised and stored at 16 °C (Fig. 5.1.4.1) may suggest that any effect on chlorophyll content due to time cut from the plant was minimal. Therefore, the time spent cut from the plant during and after thawing of the test samples could be discounted as an influencing factor. However, significant ($p < 0.05$) differences in chlorophyll content between tissue exposed to freezing temperatures and those at 16 °C only occur between the frozen and fresh tissue and not between the frozen and the cut and stored at 16 °C tissue (Fig 5.1.4.1). This indicates that the length of time cut from the plant does have an effect. This effect, however, cannot be the sole cause of the significant difference in chlorophyll content between fresh cut tissue and frozen tissue: If the observed difference between the 16 °C fresh tissue and the frozen tissue was purely a factor of the time the frozen tissue spent excised from the plant, there should also be a significant difference in chlorophyll content between the 16 °C fresh tissue and the 16 °C excised and stored tissue; which does not occur (Fig. 5.1.4.1). Additionally, given that

cooler temperatures should at the very least slow, if not stop, degradation, if the observed difference between fresh cut 16 °C tissue and frozen tissue was purely due to the time spent cut from the plant by the frozen tissue, it would be expected that the chlorophyll content of the frozen tissue would be higher than that of the tissue cut and stored at 16 °C. However, the data indicates a trend (although not significant) towards less chlorophyll content in the frozen tissue relative to the cut and stored at 16 °C tissue (Fig. 5.1.4.1). This would suggest that time cut from the plant is not solely responsible for the significantly reduced chlorophyll content in the frozen tissue relative to the fresh tissue, however, time cut from the plant does have enough of an effect to add sufficient variance to the chlorophyll content to remove any significant effect of damage by freezing. A further compounding factor is that the 16 °C excised and stored tissue control favours an artificially reduced difference between it and the frozen tissue: This is because during the 24 hours at 16 °C, whilst the frozen test samples are at -20 or -80 °C, the metabolism at 16 °C is not slowed, as it is in the frozen samples. Therefore, damage as a result of being cut from the plant, will be more severe in the excised 16 °C sample relative to the frozen samples. Despite this limitation the possibility of the length of time excised from the plant having an effect (even whilst frozen) does have to be accounted for by running this comparison as no studies have been performed upon the metabolic activity of these species at these temperatures; therefore, it is unknown if degradation may occur whilst frozen. Given the general, yet non-significant, trend of reduced chlorophyll content in samples exposed to freezing temperatures, relative to the excised and stored at 16°C tissue, and that standard error bars between frozen tissue and tissue not exposed to freezing do not overlap, it seems likely that with more replicates of multiple tissue fragments (for this experiment three chlorophyll extractions were performed on one or two plant fragments) this variance may be minimised resulting in a significant difference between tissue excised and stored at 16 °C and frozen tissue.

There was no difference in chlorophyll content of *Calluna vulgaris* samples between -20 °C and -80 °C (Fig. 5.1.4.1), indicating that both temperatures are equally damaging. Given the reduced chlorophyll content, therefore implying reduced plant health, of samples exposed to freezing shocks of -20 °C and -80 °C relative to the 16 °C samples (Fig. 5.1.4.1), it seems likely that this sample is not constitutively freezing tolerant (at least to -20 °C). The sample comes from an altitude between 500 and 600m above sea level and records show that temperatures of -20 °C are occasionally reached in winter at the nearby station, Aviemore (228m above sea level) (WeatherOnline, 1999-2018), with occasional summer freezing temperatures (WeatherOnline, 1999-2018) and a high variability in summer temperature. For example a weather station in Braemar (also nearby and 327m above sea level) recorded the UK highest and lowest temperature maxima and minima on the same day in September 2015 (24 °C and - 0.3 °C) (Met-Office, 2016). Either these summer freezing temperatures are sufficiently rare that although minimal damage may occur, the risk outweighs the benefit of increased growth through a lack of constitutive freezing tolerance (Achard et al., 2008, Suo et al., 2012, Liu et al., 1998, Gilmour et al., 2000, Pino et al., 2007) or, more likely, there is a basal freezing tolerance conferred for mild freezing temperatures (greater than the -20 °C tested). This basal level is either then increased upon acclimation signals for more extreme freezing events or regular low temperatures maintain acclimation. However, once plants are in controlled warm environments this basal level is lost. Previous studies indicate that *Calluna vulgaris* is freezing tolerant to around -15 °C in the wild, during months they are likely to be acclimated (April and October) (Sæbø et al., 2001, Caporn et al., 1994) which would explain the inability to tolerate temperatures below -15 °C prior to acclimation and support the evidence that the tissue was killed at both -20 °C and -80 °C. However, it seems unlikely that all *Calluna vulgaris* plants are incapable of tolerating temperatures below -15 °C after acclimation, given that the parent plant donor plant likely experienced

temperatures below -20 °C in its natural environment (WeatherOnline, 1999-2018, Met-Office, 1959-2018). Comparisons between freezing tolerance (such as via electrolyte leakage assays) before and after acclimation for *Calluna vulgaris*, coupled with realtime results of *CBF* expression (if *CBF* could be isolated from *Calluna vulgaris* via another method such as full genome sequencing) may, therefore, isolate differences between plants with differing environmental origins.

5.2.4.2 *Empetrum nigrum*

The significantly higher chlorophyll content in the cut tissue stored at 16 °C relative to the freshly cut tissue (Fig. 5.1.4.1) would indicate that the fresh tissue has potentially undergone a damaging incident not experienced by the tissue stored at 16 °C. Since all tissue samples were cut at the same time, this cannot be explained by any stress experienced by the plant prior to the collection of fresh tissue, but post collection of the stored at 16 °C tissue. The fresh cut tissue was immediately frozen in liquid nitrogen (~-196 °C) prior to transfer and storage at -80 °C. It was then re-transferred to liquid nitrogen immediately prior to freeze drying. *Empetrum nigrum* has thick, fleshy and waxy leaves, it is therefore possible that damage occurred whilst warming, due to prior freezing, during the 24 hour freeze drying process if sublimation did not reliably occur. The 16 °C stored tissue may not have experienced as much damage as it would have already undergone some desiccation from having spent time excised from plant. Therefore, it would undergo less freezing damage when stored in the -80 °C due to less available water to result in ice formation and it would also be quicker to desiccate when freeze-dried due to being partially desiccated prior to being freeze-dried. Another possibility is that the prior desiccation may have resulted in increased freezing tolerance as it is known from other species that there are shared pathways between drought and freezing acclimation; one inferring tolerance to the other (Haake et al., 2002). It is also been shown that

acclimated *Empetrum nigrum* can survive at -80 °C (Yamori et al., 2005), therefore, the tissue stored at 16 °C may have been acclimated and as a result less damaged by freezing at -80 °C and immersion in liquid nitrogen.

Another and potentially compounding possible factor was that -80 °C may be insufficient to completely cease all metabolic activity, no studies have been performed on the metabolic activity of *Empetrum nigrum* at -80 °C however *Empetrum nigrum* is able to survive at -80 °C after acclimation (Yamori et al., 2005). Therefore, it is possible that the “fresh” tissue, after undergoing potentially severe freezing damage in liquid nitrogen, may have started to degrade at -80 °C. Therefore, the fresh sample stored at -80 °C (for 4 days longer than all other samples) may have undergone degradation after damaging freezing stress in liquid nitrogen whereas the sample stored at 16 °C was immediately transferred to -80 °C (with no liquid nitrogen step) and stored for two days prior to being placed in liquid nitrogen for freeze drying.

Other explanations or compounding factors include that tissue age may influence chlorophyll content, although young tissue was preferentially selected it is possible that tissue of a different age, with a differencing level of chlorophyll content, was used for the fresh sample. However, the most likely explanation is that the fresh sample (containing a higher water content due to lack of 72 hours at 16 °C which would result in partial desiccation in the other samples) did not undergo full desiccation during freeze drying, therefore when weighed prior to grinding water would still be present adding to the apparent “dry” weight therefore reducing the apparent chlorophyll content per gram of dry weight result.

The chlorophyll a content of tissue exposed to -80 °C was significantly higher than for the -20 °C ($P < 0.01$) and 16 °C fresh tissue ($P < 0.05$) however this is not seen for chlorophyll b or total (a+b) chlorophyll (Fig. 5.1.4.1). That there is significantly more

chlorophyll a but not b may be a reflection of the scale, namely that there is more of a than b so slight variations in readings have a greater effect on the error of chlorophyll b. The significantly higher chlorophyll a content in the -80 °C sample could therefore imply that the -20 °C and 16 °C samples have undergone greater damage. A possible explanation as to why the 16 °C and -20 °C tissue may have showed signs of greater damage than the -80 °C sample could be that -20 °C does not entirely stop metabolic activity. Therefore, being removed from the plant has initiated degradation and chlorophyll loss to the 16 °C fresh and -20 °C tissue but not the -80 °C treated tissue where metabolic activity has ceased. Alternatively, If the -20 °C and 16 °C fresh samples had a different initial chlorophyll a:b ratio than the -80 °C treated sample this could explain the significant difference in chlorophyll a but not b or total chlorophyll. Differences in chlorophyll a:b ratios could be due to shading by other parts of the plant, as shading is known to increase chlorophyll b relative to a (Shao et al., 2014, Muhidin et al., 2018) or differing tissue ages (Day et al., 1996). Total chlorophyll loss, however, remains constant across all three treatments (Fig. 5.1.4.1). Given the significant, and larger, decrease in both chlorophyll a and b at -80 °C and -20 °C relative to the 16 °C excised tissue and the aforementioned probable decrease in apparent chlorophyll content in the 16 °C fresh tissue; it is more likely that both the -20 °C and -80 °C treated tissue samples have been severely damaged. Therefore, the apparent variation in chlorophyll a is more likely due to the aforementioned possible differences in tissue and initial chlorophyll a:b ratios as opposed to greater survival at -80 °C.

Despite compounding factors and an unusual fresh tissue result, these results do indicate, however, that the plant sample studied (232) is not constitutively acclimated to withstand freezing shocks of -20 °C; sample 232 was a cutting from a plant found 1100m above sea level where freezing events would be common (and was collected above patches of mountain snow lie in July (personal obs.)). For example, the nearby lower altitude (339m)

Braemar weather station records a minimum close to 5 °C or lower almost every month (Met-Office, 1959-2018), therefore the plant at 1100 m above sea level would likely experience much lower and freezing temperatures all year round. Yamori et al., (2005) found that *Empetrum nigrum* can withstand ~-15 °C prior to acclimation, indicating that basal freezing tolerance is high and therefore increased freezing tolerance is not required except in response to consistent low or freezing temperatures. It is therefore probable that -20 °C and -80 °C killed the non-acclimated tissue samples and the variation seen is due to other factors (discussed above).

Another way of assessing freezing tolerance *Empetrum nigrum* may be via electrolyte leakage freezing assays. However given the ability to tolerate extremely low temperatures, especially after acclimation (Yamori et al., 2005) precision temperature drops within the desired range -10 °C to -90 °C would be difficult to achieve. An alternative possibility would be to investigate the effect of mild freezing on photosynthetic activity and plant health upon recovery, to identify if any difference in tolerance and rate of recovery is seen between plants from different locations. This could be assessed via methods such as chlorophyll fluorescence and infra red gas analysis (IRGA).

5.2.5 The Association of the Environmental Origin of the Parent Donor Plant with the Morphology of Common Garden Grown Cuttings of *Empetrum nigrum* and *Calluna vulgaris*

Different plants taken from cuttings from wild plants displayed a variety of different morphologies when grown in common conditions, implying that there is a genetic influence upon the morphology. Possible causes of these differences include: Genetic selection favouring certain morphologies under certain environmental conditions; genetic drift within the populations due to spatial separation of populations due to fragmented

environments (both manmade and natural); epigenetic traits carried across in the cuttings i.e. cutting grown plants carried over a genetic memory, and therefore activation of genes appropriate for their previous environment. These genetic differences could also be either inherent (i.e. always the case e.g. compact plants came from cuttings from compact donor parent plants) or plastic with the morphology changing relative to the parent donor plant due to the change of environment in which the cuttings were grown relative to the environment of origin (i.e. plants from different environments may alter their morphologies in different ways in response to the change of environment given their previous environment, e.g. the common garden temperature may be, on average, warmer or cooler than previous environment, nitrogen status may be more or less than previous environment, different light levels etc).

The presence of significant correlations in the controls; longitude with altitude and longitude with latitude for *Empetrum nigrum* and longitude with latitude for *Calluna vulgaris* means that these factors cannot be isolated from one another to analyse their effect upon morphology. Other environmental factors not recorded which may also correlate in some way could also have an impact upon morphology. One factor, for example, could be related to the samples from Galloway (the west-coast of Scotland) frequently being outliers as well as being the furthest west and lowest altitude samples. For example these locations, being on the west coast, are also from the wettest location (although not substantially wetter than the Cairngorms) (Met-Office, 1981-2010) and the majority of Galloway: Portpatrick samples were collected on the beach edge where they would experience salt stress. There was only one example of *Empetrum nigrum* that could be found in Galloway, this was an individual extremely large plant on a coastal beach path under a large overhang, no nearby plants could be found. Therefore, as well as the problems associated with inferring a pattern with only one example from a location it also seems likely that this particular example may not be from the area and a recent invader,

potentially via seed spread by users of the coastal path. The correlation of longitude with altitude does not occur in *Calluna vulgaris*. Samples of *Empetrum nigrum* and *Calluna vulgaris* were collected from the same sites wherever possible so the cause of no correlation in *Calluna vulgaris* is not due to different collection site locations but due to the much higher number of samples collected from low altitude in Galloway (furthest west site) where *Empetrum nigrum* was not present in abundance. If the Galloway samples were removed from the analysis, *Calluna vulgaris* would show a similar correlation between longitude and altitude.

These problems are further compounded in *Empetrum nigrum* by the samples from the Cairngorms: they are both the most northerly and highest altitude plants with the largest representation from the various locations. They are also the only specimens with compact forms (i.e. greater than 5.5). If the Cairngorms group were removed from the scatter plots the positive trend between compactness and latitude would be lost, in contrast a slight negative trend may be seen (Fig. 5.1.5.3.3). This indicates that it is unlikely that latitude has as significant effect upon morphology as shown by the statistical tests. If the Cairngorms samples were removed from the longitude scatter graphs, however, a similar negative correlation pattern would still be seen. Given that longitude and latitude are themselves negatively correlated with one another the negative correlation of one factor with compactness could be driving the other towards an apparent negative correlation. Given the more consistent negative correlation of longitude with compactness (i.e. not altering upon addition/removal of Cairngorms samples) it seems likely that longitude will be impacting upon the apparent negative correlation (upon removal of the cairngorms samples) of compactness with latitude. However, given the current data this cannot be tested. The strong correlation of altitude with compactness appears to be the most reliable correlation: If the Cairngorms samples are removed a positive trend between altitude and compactness is still present. If the Cairngorms data points are analysed in isolation of all

other samples the positive trend is still seen and this eliminates the compounding factors of latitude and longitude. It therefore seems probable that given sufficient adjustment to collection methods to reduce compounding factors (see later) this correlation may still be seen. However, no reliable conclusions can be drawn with the current limitations.

Arctic and alpine plants have a dwarf and frequently compact growth form (D. Billings, 1973) so a correlation in compactness with altitude is not unexpected. However, this compact form or dwarfism is typically associated with separate species rather than within the same species. Well known examples include trees such as the prostrate willow *Salix herbacea* and cushion plants such as *Silene acaulis* which have taller, non-dwarf, counterparts in the same genus at lower latitudes and altitudes. The dwarfism of the majority of arctic and alpine plants is clearly genetic, as they are frequently grown in low altitude and latitude gardens as ornamental plants, with the dwarf morphology continuing through future lowland-grown generations. The genetic cause of this dwarfism is unknown, and indeed may not be a single cause for all species. Dwarf *Arabidopsis thaliana* can be found on swiss mountain slopes (Luo et al., 2015) and these plants have greater fitness in alpine locations than non-dwarf *A. thaliana* (Luo et al., 2015). Upon investigation Luo et al., (2015) found that the cause of the dwarfism in two dwarf accessions (of 12) was a single nucleotide deletion in the gene encoding GA 20-oxidase (*GA5*) (an enzyme in the GA_3 pathway). However this does not indicate that this is the causative factor for all species and indeed was not found in other dwarf accessions within the species (Luo et al., 2015), 10 of 12 accessions remaining unexplained, including the highest altitude accession. Overexpression of *CBF* genes is associated with dwarfism (Achard et al., 2008, Suo et al., 2012) and since this infers constitutive freezing tolerance (Knight and Knight, 2012) as well as inferring the advantages of compact dwarfism in these environments (such as remaining near the boundary layer, limiting damage from wind and ice, producing own microclimate and taking advantage of microclimates) would

also protect against freezing all year round, assuming the same mechanism of freezing tolerance is utilised by these plants. However arctic and alpine plants do acclimate (Yamori et al., 2005, Stushnoff and Junttila, 1986) so are not constitutively acclimated, though upon acclimation they are able to tolerate temperatures much lower than plants typically studied for *CBF* overexpression, such as *Arabidopsis thaliana* and *Glycine max* (Achard et al., 2008, Suo et al., 2012, Hannah et al., 2006). The basal level of freezing tolerance is also higher (tolerating lower temperatures) than the basal level of typically studied *A. thaliana* and crop species (Yamori et al., 2005, Stushnoff and Junttila, 1986, Odasz, 1990, Jaglo-Ottosen et al., 1998, Hannah et al., 2006, Staggenborg et al., 1996). This indicates that either a secondary mechanism is involved or there is a greater expression of *CBF* or a more potent form with a basal level of expression all year round which increases to a much higher level upon acclimation. Whilst greater expression or more potent *CBF* genes would be an interesting explanation for arctic and alpine dwarfism this has not been studied and preliminary tests on a high altitude and latitude *Empetrum nigrum* vs a low altitude and latitude *Empetrum nigrum* are inconclusive (see section 5.2.3). It is however possible that the sample from a higher altitude and latitude does have a higher basal expression of *CBF* (See sections 5.1.3.4.2 and 5.2.3.4.2). However, expression results are highly unreliable and further study would be needed.

The greater number of *Calluna vulgaris* plants increased the robustness of the Spearman's rank correlation tests but confounding factors, predominantly related to collection site, are still a problem. A weaker correlation between compactness and longitude was seen for *Calluna vulgaris* (-0.4 vs -0.8 for *Empetrum nigrum*) the correlation in this case appears less strong due to several compact samples from Yorkshire. Rather than another environmental aspect of Yorkshire having an effect upon morphology weakening the apparent trend, it seems more probable that this apparent negative trend may be a symptom of a very small number of plants from several sites in the longitude range

between the Cairngorms and Yorkshire (North Pennines (n=3), Wales (n=3) and Derbyshire (n=6)) which score with a less compact morphology. Given the large range of compactness scores at each longitude where there are a larger number of samples it seems likely that the score range when only a small number of samples were taken will not be representative of the true range. The positive trend between compactness and latitude is similarly unreliable, as well as being unable to distinguish effects due to longitude vs latitude (due to the correlation of the two variables), this trend is due to the higher compactness levels of the two Scottish samples (Galloway and The Cairngorms). These locations have previously been identified as unusual, in that the Cairngorm samples are from the highest altitude far surpassing that of any other site and not having any low altitude examples. Therefore, the effect of altitude in this case cannot be discounted. Both Galloway and the Cairngorms also receive higher rainfall than all other sample sites (Met-Office, 1981-2010) and Galloway samples are also typical outliers with the lowest altitude and no high altitude examples. Galloway samples were also collected from on, or immediately adjacent to, the beach (Portpatrick) or from under woodland (Glentroot) so other environmental factors are of especially high risk in this case (such as shade or salt adaptations) therefore the reliability of this apparent correlation is in question. The apparent negative correlation (-0.4) between altitude and compactness is also in question. This relatively weak correlation seems primarily driven by the low altitude Galloway samples which all display a much more compact morphology relative to other sites. If these samples were removed this trend would be substantially weakened. Unlike in *Empetrum nigrum*, neither a positive nor negative trend is immediately apparent from the scatter plot when looking only at the Cairngorms samples thereby removing the majority of other influencing environmental factors. It therefore seems likely that this correlation between altitude and compactness is not reliable and that other environmental factors are causing this correlation.

It should also be noted that compactness ranks between *Calluna vulgaris* and *Empetrum nigrum* are not directly comparable. Criteria for compactness were subtly different; a score of 1 was used for the most leggy plant and 10 for the most compact, this range varied between the two species. Leggy *Calluna vulgaris* is still quite bushy whereas leggy *Empetrum nigrum* was typically one or two long continuous creeping stems. *Empetrum nigrum* seemed much more plastic in its morphology, therefore the range of morphologies between 1 and 10 for *Empetrum nigrum* was much larger than the range between 1 and 10 for *Calluna vulgaris*.

Some of the aforementioned limitations and confounding factors preventing clear analysis could be overcome via a comprehensive and strategically planned collection. The samples were not collected with this analysis in mind, sample locations were chosen to cover large sections of the UK in a limited window of time (with two collection days at each site, 3 in the Cairngorms). These sites were also chosen for convenience, differing maxima and timing of freezing events (Met-Office, 1981-2010) and where there were known records of both *Calluna vulgaris* and *Empetrum nigrum* plants growing (BSBI, n.d.). Numerous plants also died prior to study due to regular failures of the growth chambers greatly reducing plant numbers. The effect of latitude vs compactness and altitude vs compactness is of the most interest for this study, due to increased severity and frequency of freezing events with increasing latitude (Met-Office, 1981-2010) and altitude (Met-Office, 2017). It is harder to limit environmental effects across a latitudinal gradient and it is limited by the geology of the study area, however the robustness of this study could still be greatly improved by collecting numerous samples across multiple latitudinal gradients thus limiting longitudinal effects. Altitude had the strongest evidence for a possible correlation in *Empetrum nigrum* and would be of the greatest interest for further study. The indication that a correlation can be seen across an altitudinal gradient at one site (Fig 5.1.5.3.3: Cairngorms) indicates that multiple studies limited to one altitudinal

gradient each may be possible, which would limit other potential environmental factors. Numerous altitudinal gradients on both slope sides, to account for other potential differing conditions on different faces, could be analysed both individually (i.e. 1 mountain and facing) grouped (all mountains of one facing) and all together (i.e. all mountains and facings). The factor of longitude and latitude would be essentially removed (due to being on too small a scale to cause an effect) and environmental differences would be largely removed. Altitude would still tend to have compounding factors such as soil quality and depth generally decreasing as higher altitudes are reached along with a change in the degree of wind exposure however microclimates would also have an effect and would alter not with the altitudinal gradient but with topology. The possible effect of ploidy level on morphology (see 5.2.6 A Note on *Empetrum nigrum* subspecies) could also be addressed in such a study and it would be interesting to compare distribution, ploidy level and flower morphology with overall plant morphology.

5.2.6 A Note on *Empetrum nigrum* Subspecies

It should be noted that a potential compounding factor in the analysis of *Empetrum nigrum* samples is that there are two subspecies of *Empetrum nigrum* (*subsp. nigrum* and *subsp. hermaphroditum*). These two subspecies are almost identical. Debate surrounds the defining characteristics between the two species and is not recent (e.g. (Bell and Tallis, 1973)). Initial description of (at the time described as a new species) indicated that *E. nigrum subsp. hermaphroditum* was a tetraploid (whereas *E. nigrum subsp. nigrum* was diploid) with hermaphroditic flowers (Hagerup, 1927). Traditional identification resources indicate that the flower morphology is the key identifying factor; *E. nigrum subsp. nigrum* is dioecious whereas *E. nigrum subsp. hermaphroditum* is hermaphroditic (Rich et al., 1992). However (Suda et al., 2004) found some examples of diploid plants with hermaphroditic flowers (the archetypical feature for *Empetrum nigrum subsp.*

hermaphroditum) in the Czech republic. Diploid plants with hermaphroditic flowers have also been identified within the UK (Blackburn, 1938). Whilst all tetraploids studied by Suda et al., (2004) had hermaphroditic flowers, sterile triploid individuals were also observed (Suda et al., 2004). Both those identified morphologically as *E. nigrum subsp. hermaphroditum* and *subsp. nigrum* covered a wide range of overlapping altitudes and environments; the predominate separating feature being different mountain ranges (Suda et al., 2004). Similar overlapping ranges have been reported elsewhere using ploidy level as the defining characteristic between the two species (Suda, 2002). Traditional identification guides also refer to “atypical” individuals when morphologically identifying between the two subspecies (Rich et al., 1992) and that the ranges of the two subspecies overlap (BSBI et al., n.d., Rich et al., 1992). It can therefore be argued that these two subspecies cannot be reliably identified between using flower morphology or range. Mention of differing growth morphology has been made between the two alleged subspecies, namely that *Empetrum nigrum subsp. nigrum* has a propensity to be more sprawling whereas *Empetrum nigrum subsp. hermaphroditum* is typically more compact (Rich et al., 1992). However, no mention of how these subspecies were originally identified prior to making this observation is made, it is unlikely to be ploidy level given that the source is an identification guide, leaving either flower morphology or location which as previously discussed are not reliable indicators. This study also found a continuing gradient of morphologies with no clear differentiation into two groups (Fig. 5.1.5.3.3). If altitude and latitude does affect morphology (see sections 5.1.5 & 5.2.5), the apparent more compact form *Empetrum nigrum subsp. hermaphroditum* may have more to do with its association with high altitude and latitude locations rather than distinguishing features of two subspecies. Ploidy level would, therefore, have to be taken as the defining characteristic, as triploids have been reported as sterile and no evidence of backcrossing has been found (Suda, 2002, Suda et al., 2004) however this was a limited

study and does not exclude the possibility of backcrossing. The majority of identification will likely still rely on morphology therefore previous identifications of one subspecies over another cannot be taken as reliable. *MATK* sequencing suggests no difference between the two subspecies (Fig. 3.1.3.1a-c) however it is unknown how those species were identified (by ploidy, flower morphology or distribution). Interestingly in other species which have both diploids and tetraploids, the diploid is often the more cold tolerant and found in glacial refugia (with the tetraploid found in previously glaciated areas) (Parisod et al., 2010). Whilst the references for other species seem accurate in Parisod et al.'s (2010) review these authors also claim that the tetraploid of *Empetrum nigrum* is more cold tolerant referencing Elvebakk and Spjelkavik, (1995) in support of this. Unfortunately, Elvebakk and Spjelkavik (1995) merely discuss the presence and distribution of *Empetrum nigrum subsp. hermaphroditum* in Svalbard, using flower morphology as the identifying factor, yet no study of ploidy level is made (Elvebakk and Spjelkavik, 1995). It seems likely Parisod et al., assumed that all *Empetrum nigrum subsp. hermaphroditum* are hermaphroditic and tetraploid, however as earlier discussed this is not the case. Phlogenetic trees based on multiple plastid genes found examples of both tetraploid and diploid *Empetrum nigrum* in two clades (Popp et al., 2011). The separate ploidy levels did not separate out with some samples of *Empetrum nigrum* (both diploid and tetraploid) showing greater similarity to a subclade of *Empetrum rubrum* than to other *Empetrum nigrum* (both diploid and tetraploid) (Popp et al., 2011). It therefore seems likely that multiple ploidy events have occurred within *Empetrum nigrum* and therefore that ploidy level cannot be reliably used as subspecies identification either. There was no discussion of flower morphology associated with the phylogenetic tree (Popp et al., 2011), however it seems likely as discussed earlier, that flower morphology is not necessarily a reliable indicator either. It is therefore possible that these two subspecies are indeed not subspecies, but represent plasticity within the genus. Therefore, for the

purpose of this study no attempt to distinguish between the two alleged subspecies was made. However, the possible effect of polyploidy upon cold and freezing tolerance in *Empetrum nigrum* would be of interest for further study.

Chapter 6: General Discussion

Although none of the amino acid mutations within *CBF1* were conclusively demonstrated as influencing freezing tolerance, several paths for further investigation into these amino acid changes were identified. Continued investigation into single amino acid changes to native *CBFs* is a route of interest for crop breeding because single amino acid mutations are possible to achieve without use of standard genetic modification. Therefore, if a single amino acid mutation is found to beneficially alter freezing tolerance, conventional breeding techniques (which includes mutagenic breeding) could be used and the mutation screened for via marker assisted selection thereby avoiding restrictions imposed with genetic modification. Simple amino acid changes are, therefore, preferential to the introduction of entirely new *CBF* genes. Since the results gathered with single amino acid changes were inconclusive further study would be beneficial. Constitutive overexpression of *CBFs* containing these mutations resulted in the same dwarfing and reduced yield issues as seen with overexpression of native *Arabidopsis thaliana* *CBF* genes (Achard et al., 2008, Gilmour et al., 2000, Liu et al., 1998). Replacement of the native promoter with a constitutive promoter or the addition of a constitutive promoter to native *CBFs* would be nigh impossible using traditional (non GM) breeding methods due to the large changes that would need to be made. Therefore, on two fronts, *CBF* overexpression is only of interest as a diagnostic tool and not as a solution for improving crop plants. The behaviour of mutated *CBFs* under the control of standard *CBF1* promoters would therefore be of interest and bypass the growth problems associated with overexpression (see section 4.2.2.1). The effect of these mutations, if any, could then be studied both prior and post acclimation. In this way it could be assessed if these mutations result in any change in the basal pre-acclimation freezing/cold tolerance and if there is any effect upon plant growth, as well as assessing any change in maximal freezing tolerance upon acclimation. Increased basal tolerance would be advantageous to crops in providing protection against

early or late frosts and, possibly, midwinter de-acclimation. An increase in maximal freezing tolerance would allow for growth in locations where winter conditions are too cold for the crop to currently be grown or where extreme winter freezing events are likely to increase. Therefore, either, or both, of these changes would prove desirable crop traits. However, there is a risk that any increased basal tolerance may result in similar, but milder, unwanted effects as seen in overexpressors; namely dwarfing and reduced yield. Therefore, if the *CBF* mutations proved to be more potent and alter basal freezing tolerance, further study would therefore be required to assess if growth limitations occur and whether benefit to the crop outweighs that of any potential loss in yield.

The first step to assess the possibility of single amino acid changes altering either maximal (upon acclimation) and/or basal (pre-acclimation) freezing tolerance would be to further investigate the binding and potency of CBF proteins containing these mutations. Binding ability could be assessed via *in vitro* electrophoretic mobility shift assays as exemplified by Canella et al., (2010) and potency could be assessed via improved realtime expression methods as discussed in section 4.2.2. If more potent or stronger binders were found they could be introduced either additionally to the native *CBFs* (i.e. as per sections 2.5.2 and 2.8 but with a normal promoter as opposed to a constitutive 35S promoter) or by modifying the native *CBF1* via site directed mutagenesis (genome editing). Modification of the native *CBF1* by site directed mutagenesis would be preferential as it would not result in the introduction of additional *CBF* genes (as with normal transformation) and therefore would not alter the *CBF* copy number (see below). Changes in freezing tolerance, both pre- and post acclimation, could then be compared alongside assessments, under non-acclimated conditions, on the effect, if any, upon health and yield (as discussed above). Other cold regulated native *CBF* genes could also be mutated (*Arabidopsis thaliana CBF2* & *CBF3*) as it is possible that different mutations may affect different *CBF* genes differentially or result in different degrees of effect.

One possible method of increasing freezing tolerance worthy of further investigation is that of increasing *CBF* copy number. Greater *CBF* copy number has been associated with increased winter hardiness in barley and wheat cultivars (Knox et al., 2010, Wurschum et al., 2017). There is also a possibility that tetraploidy (therefore containing twice the gene copy number of diploid plants) in *Empetrum nigrum* is associated with environments that experience lower temperatures than the diploid plants (see section 5.2.6). It would be extremely interesting to artificially change the *CBF* copy number (under normal promoters) in *Arabidopsis thaliana* and assess the change, if any, upon maximal and basal freezing tolerance. There are a variety of methods which could be used to explore this possibility. To explore the possibility of the effect of polyploidy upon freezing tolerance a complete genome duplication event could be initiated via methods such as the application of colchicine (Nebel, 1937) . Another study, purely looking at the increase in *CBF* genes, could also be performed using stable transformation (as per sections 2.5.2 and 2.8). Different numbers of tandem copies per gene insert could be used to insert tandem repeats of varying copy number into the genome. Alternatively, a variety of different strains of agrobacterium, with different virulence, could be used to induce varying numbers of multiple transformation events. The number of transformation events per line could then be calculated. *CBF* copies would not be in tandem using this method instead they would be scattered through the genome. These transformed plants could then be assessed as per section 4.1.2. Depending on the results the effect of tandem vs scattered increased copy number could also be assessed. Polyploidy and tandem duplication (as opposed to a scattered increase in copy number) are the most likely genetic alterations that could be induced in crops without resorting to genetic modification and therefore of greater interest.

Another route of exploration is the effect of differing *CBF* expression kinetics. The ability to alter the kinetics of *CBF* expression in crops would be of great interest, potentially

being able to change the rate of acclimation, change freezing tolerance levels, alter the time to reach maximal freezing tolerance, alter responses to freeze thaw cycles and alter the timing of deacclimation. Changing the rate or responsiveness of *CBF* expression and therefore the rate of acclimation would allow for breeding of crops with more rapid responses to low temperatures (in areas where low temperatures are likely to indicate freezing) or slower responses (where low temperature fluctuations are regular without freezing). Changes to the basal freezing tolerance levels could protect against unexpected cold/freezing events that would otherwise be damaging e.g. (Brammer, 2018, News Staff, 2012, Ewing, 2013, The Local, 2017, Park, 2018). Whereas changes to the maximal freezing tolerance would protect against lower freezing temperatures in winter. This could allow growth of crops in new colder areas or continued growth of crops in areas where temperatures in winter more likely to experience extremes as a result of climate change (such as currently experienced in the eastern US (Cohen et al., 2018, Massey and Samuel, 2018)). The degree of acclimation could potentially also be able to be altered, introducing levels of acclimation between the unacclimated basal level and the maximal freezing tolerance level, these intermediate levels would be of great advantage especially during autumn/spring where early and late frosts are of great risk to crops e.g. (Brammer, 2018, News Staff, 2012, Ewing, 2013, The Local, 2017, Park, 2018) but do not result in freezing to the same degree as midwinter temperatures. An intermediate acclimation level would therefore be able to tolerate milder freezing temperatures whilst potentially still taking advantage of growing degree days during this period. If these differing levels of acclimation occur in wild populations they are most likely to be found in plants which need to maximise use of growing degree days whilst being prepared for freezing temperatures (such as in arctic and alpine environments) and, as per this study, are the most promising candidates for investigation. Response to freeze-thaw cycles and longer warm periods is also of interest due to the risk of deacclimation. The kinetics of *CBF*

expression has been found to be involved in maintaining freezing tolerance during freeze-thaw cycles in birch (Welling and Palva, 2008) Therefore, the ability to prevent crops from deacclimating whilst risk of freezing persists would be extremely advantageous. Likewise altering the rate of deacclimation could result in prolonged freezing tolerance where severe late freezing events are a risk, or during prolonged periods of warm winter temperatures where return to freezing temperatures can decimate crops e.g. Strassmann, (2017).

An excellent route of investigation of differing *CBF* kinetics would be via the species *Empetrum nigrum* and *Calluna vulgaris* as preliminarily studied within this report. These species occupy a wide range of environments, providing the potential to be able to identify differences, within a species (thereby reducing the occurrence of mutations due to divergence), which may alter *CBF* expression kinetics. This study provided preliminary data suggesting that *Empetrum nigrum* plants from different environments of origin have identical *CBF* sequences but differing *CBF* kinetics. As well as *Empetrum nigrum* and *Calluna vulgaris* potentially being useful to identify differences which alter *CBF* expression kinetics which may prove of use for crops, these species are also worthy of investigation in their own right. Both of these species are dominant ground cover species in subarctic and moorland environments, so further understanding of how these populations are composed and how climate change may affect their distribution and survival is of utmost importance. This understanding could also help guide peatland restoration and reintroduction programs. As well as being of high environmental value they are also of commercial and cultural value: *Calluna vulgaris* is vital for grouse moorlands providing a primary diet for red grouse and is an iconic moorland species the loss of which would affect tourism. *Empetrum nigrum* is a minor crop in its own right and is also grazed by reindeer herds (Inga and Öje, 2012) which are vital for the livelihoods of indigenous reindeer herders such as the Sami (Heikkilä, 2002). There is,

therefore, a strong case for full genome sequencing of both these species. Full genome sequencing would allow for identification of all *CBF* genes; a limitation of the project project is the inability to assess if other *CBF* genes are present and if so how many are present, their sequence and how their expression changes. Additionally, quantitative transcriptome sequencing could also be performed which would then allow for identification of which stimuli these *CBF* genes respond to e.g. cold like *Arabidopsis thaliana* *CBF1-3* (Gilmour et al., 1998) or drought as with *A. thaliana* *CBF4* (Haake et al., 2002). Genome sequencing would also overcome some of the problems discussed in section 5.2.3 and 3.2.1.1 and allow for easier and more complete further study of these species. Once sequences are known for one member of the species primers could be designed to isolate genes of interest from multiple members of that species and compare these genes for the possibility of regional differences. Having a full genome sequence would also make the study of the *CBF* promoters (of unknown sequence) possible. *Calluna vulgaris* *CBF* sequences could also be isolated and the species studied as with *Empetrum nigrum*. The first step would be to first optimise the qPCR, which has a far greater chance of success with a full genome sequence (Section 5.2.3) and perform expression analyses on all *CBF* sequences on multiple samples to check for differences in expression kinetics. Long (weeks-months) time courses could also be performed to determine how expression varies over a prolonged period as discussed in section 5.2.3. The sequence and relative positioning of the promoters of these samples could then be studied and compared between samples showing different expression kinetics. If sequence differences were present their effect and significance could be investigated in vivo in *Arabidopsis thaliana* as were performed with the *CBF* sequence differences found in this project. Full genome sequencing on multiple samples of the same species from different locations could also allow for the comparison of *CBF* copy number (as discussed above). Other genes involved in cold acclimation could also be investigated and isolated

from multiple samples following full genome sequencing. A prime candidate gene for further study would be ICE1; a transcription factor involved in the upregulation of *CBF* (Chinnusamy et al., 2003).

In conclusion, *CBF* continues to be a worthwhile route of continued investigation for analysing and altering acclimation and freezing tolerance. Likely routes of further study have been proposed. Amino acid modifications of interest are highlighted along with suggested methods of further analysis. The copy number of *CBF* and the effect of ploidy is also a possible factor that effects freezing tolerance and acclimation and deserves further investigation; suggested methodology is described above. *CBF* expression kinetics are highlighted as being of interest. Continued exploration of *CBF* expression kinetic differences within a species is warranted to elucidate the origin of these differing kinetics and their effect upon freezing tolerance and acclimation. *Empetrum nigrum* is identified as a key species ideally suited for such studies.

Bibliography

- ACHARD, P., GONG, F., CHEMINANT, S., ALIOUA, M., HEDDEN, P. & GENSHCHIK, P. 2008. The cold-inducible CBF1 factor-dependent signaling pathway modulates the accumulation of the growth-repressing DELLA proteins via its effect on gibberellin metabolism. *Plant Cell*, 20, 2117-29.
- ACIA 2005. Arctic Climate Impact Assessment. *Cambridge University Press*.
- AGARWAL, P. K., GUPTA, K., LOPATO, S. & AGARWAL, P. 2017. Dehydration responsive element binding transcription factors and their applications for the engineering of stress tolerance. *Journal of Experimental Botany*, 68, 2135-2148.
- ALPINER. 2005. *Starting Seeds for Dryas and Fritilaria* [Online]. Available: <http://forums.gardenweb.com/discussions/1719221/starting-seeds-for-dryas-and-fritilaria> [Accessed 2014].
- ALTSCHUL, S. F., GISH, W., MILLER, W., MYERS, E. W. & LIPMAN, D. J. 1990. Basic local alignment search tool. *J Mol Biol*, 215, 403-10.
- ARTUS, N. N., UEMURA, M., STEPONKUS, P. L., GILMOUR, S. J., LIN, C. & THOMASHOW, M. F. 1996. Constitutive expression of the cold-regulated Arabidopsis thaliana COR15a gene affects both chloroplast and protoplast freezing tolerance. *Proceedings of the National Academy of Sciences*, 93, 13404.
- BELL, J. N. B. & TALLIS, J. H. 1973. *Empetrum Nigrum L.* *Journal of Ecology*, 61, 289-305.
- BENISTON, M. 2005. Warm winter spells in the Swiss Alps: Strong heat waves in a cold season? A study focusing on climate observations at the Saentis high mountain site. *Geophysical Research Letters*, 32.
- BLACKBURN, K. 1938. On The Occurrence of a Hermaphrodite Plant of *Empetrum Nigrum L.* *The Journal Of Botany*, 76, 306-307.
- BLAMEY, M., FITTER, R. & FITTER, A. 2003. *Wild Flowers of Britain and Ireland*, London, A&C Black.
- BLUESTONEPERENNIALS. *Minuartia verna Caespitosa* [Online]. Available: <https://www.bluestoneperennials.com/MIIM.html> [Accessed 2014].
- BOKHORST, S. F., BJERKE, J. W., TØMMERVIK, H., CALLAGHAN, T. V. & PHOENIX, G. K. 2009. Winter warming events damage sub-Arctic vegetation: consistent evidence from an experimental manipulation and a natural event. *Journal of Ecology*, 97, 1408-1415.
- BRAMMER, J. 2018. Frost and freezing temperatures cause damages Wheatbelt grain crop. *PerthNow*.
- BRITISH BRYOLOGICAL SOCIETY 2010. *Mosses and Liverworts of Britian and Ireland a Field Guide*, United Kingdom, Bitish Bryological Society.
- BSBI. n.d. *Distribution Maps* [Online]. Available: <https://bsbi.org/maps> [Accessed 2016].
- BSBI, BRC, CEH; & JNCC. n.d. *Online Atlas of the British and Irish Flora* [Online]. Available: <https://www.brc.ac.uk/plantatlas/plant/empetrum-nigrum-subsp-hermaphroditum> [Accessed 16/12/18].
- CANELLA, D., GILMOUR, S. J., KUHN, L. A. & THOMASHOW, M. F. 2010. DNA binding by the Arabidopsis CBF1 transcription factor requires the PKKP/RAGRxFxETRHP signature sequence. *Biochimica et Biophysica Acta (BBA) - Gene Regulatory Mechanisms*, 1799, 454-462.
- CAPORN, S. J. M., RISAGER, M. & LEE, J. A. 1994. Effect of Nitrogen Supply on Frost Hardiness in *Calluna vulgaris* (L.) Hull. *The New Phytologist*, 128, 461-468.
- CHINNUSAMY, V., OHTA, M., KANRAR, S., LEE, B. H., HONG, X., AGARWAL, M. & ZHU, J. K. 2003. ICE1: a regulator of cold-induced transcriptome and freezing tolerance in Arabidopsis. *Genes Dev*, 17, 1043-54.

- CLOUGH, S. J. & BENT, A. F. 1998. Floral dip: a simplified method for *Agrobacterium*-mediated transformation of *Arabidopsis thaliana*. *Plant J*, 16, 735-43.
- COHEN, J., PFEIFFER, K. & FRANCIS, J. A. 2018. Warm Arctic episodes linked with increased frequency of extreme winter weather in the United States. *Nature Communications*, 9, 869.
- COOK, D., FOWLER, S., FIEHN, O. & THOMASHOW, M. F. 2004. A prominent role for the CBF cold response pathway in configuring the low-temperature metabolome of *Arabidopsis*. *Proceedings of the National Academy of Sciences of the United States of America*, 101, 15243-15248.
- COPE, T. & GRAY, A. 2009. *Grasses of the British Isles BSBI Handbook 13*, Greater London, Botanical Society of the British Isles & Royal Botanic Gardens, Kew.
- COUCH, J. & FRITZ, P. 1990. Isolation of DNA from plants high in polyphenolics. *Plant Molecular Biology Reporter*, 8, 8-12.
- CVETKOVIC, J., MÜLLER, K. & BAIER, M. 2017. The effect of cold priming on the fitness of *Arabidopsis thaliana* accessions under natural and controlled conditions. *Scientific reports*, 7, 44055-44055.
- D. BILLINGS, W. 1973. *Adaptations and Origins of Alpine Plants*.
- DAY, T. A., HOWELLS, B. W. & RYHLAND, C. T. 1996. Changes in growth and pigment concentrations with leaf age in pea under modulated UV-B radiation field treatments. *Plant, Cell & Environment*, 19, 101-108.
- ELVEBAKK, A. & SPJELKAVIK, S. 1995. The ecology and distribution of *Empetrum nigrum* ssp. hermaphroditum on Svalbard and Jan Mayen. *Nordic Journal of Botany*, 15, 541-552.
- EOL 2014. Encyclopedia of Life [Online] Available from: eol.org [Accessed: 2014-2015].
- EVANS, M., WARBURTON, J. & YANG, J. 2006. Eroding blanket peat catchments: Global and local implications of upland organic sediment budgets. *Geomorphology*, 79, 45-57.
- EWING, R. 2013. Exclusive: Frost damages nearly fifth of Brazil sugar cane crop: analyst. *Reuters*.
- FITTER, R., FITTER, A. & FARRER, A. 1992. *Grasses Sedges, Rushes and Ferns of Britain and Northern Europe*, Glasgow, HarperCollinsManufacturing.
- FOWLER, S. & THOMASHOW, M. F. 2002. *Arabidopsis* Transcriptome Profiling Indicates That Multiple Regulatory Pathways Are Activated during Cold Acclimation in Addition to the CBF Cold Response Pathway. *The Plant Cell*, 14, 1675.
- FOWLER, S. G., COOK, D. & THOMASHOW, M. F. 2005. Low Temperature Induction of *Arabidopsis CBF1*, 2 and 3 Is Gated by the Circadian Clock. *Plant Physiology*, 137, 961.
- GARDENERSHQ.COM. *Guide to Growing Mountain Avens and White Dryas* [Online]. Available: <https://www.gardenershq.com/Dryas-Mountain-Avens.php> [Accessed 2014].
- GASTEIGER, E., GATTIKER, A., HOOGLAND, C., IVANYI, I., APPEL, R. D. & BAIROCH, A. 2003. ExpASY: The proteomics server for in-depth protein knowledge and analysis. *Nucleic Acids Res*, 31, 3784-8.
- GEER, L. Y., MARCHLER-BAUER, A., GEER, R. C., HAN, L., HE, J., HE, S., LIU, C., SHI, W. & BRYANT, S. H. 2010. The NCBI BioSystems database. *Nucleic Acids Research*, 38, D492-D496.
- GIGLIO, S., MONIS, P. T. & SAINT, C. P. 2003. Demonstration of preferential binding of SYBR Green I to specific DNA fragments in real-time multiplex PCR. *Nucleic acids research*, 31, e136-e136.
- GILMOUR, S. J., FOWLER, S. G. & THOMASHOW, M. F. 2004. *Arabidopsis* Transcriptional Activators CBF1, CBF2, and CBF3 have Matching Functional Activities. *Plant Molecular Biology*, 54, 767-781.
- GILMOUR, S. J., SEBOLT, A. M., SALAZAR, M. P., EVERARD, J. D. & THOMASHOW, M. F. 2000. Overexpression of the *Arabidopsis* CBF3 Transcriptional Activator Mimics Multiple Biochemical Changes Associated with Cold Acclimation. *Plant Physiology*, 124, 1854.
- GILMOUR, S. J., ZARKA, D. G., STOCKINGER, E. J., SALAZAR, M. P., HOUGHTON, J. M. & THOMASHOW, M. F. 1998. Low temperature regulation of the *Arabidopsis* CBF family

- of AP2 transcriptional activators as an early step in cold-induced COR gene expression. *Plant J*, 16, 433-42.
- GLOBAL BIODIVERSITY INFORMATION FACILITY. Available: <http://www.gbif.org/> [Accessed 2015].
- GOETSCH, L., J. ECKERT, A. & HALL, B. 2005. *The Molecular Systematics of Rhododendron (Ericaceae): A Phylogeny Based Upon RPB2 Gene Sequences*.
- GRAAN, T. & ORT, D. R. 1984. Quantitation of the rapid electron donors to P700, the functional plastoquinone pool, and the ratio of the photosystems in spinach chloroplasts. *J Biol Chem*, 259, 14003-10.
- GUILLEMAUT, P. & MARÉCHAL-DROUARD, L. 1992. Isolation of plant DNA: A fast, inexpensive, and reliable method. *Plant Molecular Biology Reporter*, 10, 60-65.
- HAAKE, V., COOK, D., RIECHMANN, J., PINEDA, O., THOMASHOW, M. F. & ZHANG, J. Z. 2002. Transcription Factor CBF4 Is a Regulator of Drought Adaptation in Arabidopsis. *Plant Physiology*, 130, 639.
- HAGERUP, O. 1927. *Empetrum Hermaphroditum (Lge) Hagerup: A New Tetraploid, Bisexual Species*, H. Hagerup.
- HALL, T. 1999. BioEdit: a User-Friendly Biological Aequence Alignment Editor and Analysis Program for Windows 95/98/NT. *Nucleic Acids Symposium Series*, 41, 95-98.
- HANNAH, M. A., HEYER, A. G. & HINCHA, D. K. 2005. A Global Survey of Gene Regulation during Cold Acclimation in Arabidopsis thaliana. *PLOS Genetics*, 1, e26.
- HANNAH, M. A., WIESE, D., FREUND, S., FIEHN, O., HEYER, A. G. & HINCHA, D. K. 2006. Natural Genetic Variation of Freezing Tolerance in Arabidopsis. *Plant Physiology*, 142, 98.
- HARTLEY, S. E. & FIRN, R. D. 1989. Phenolic biosynthesis, leaf damage, and insect herbivory in birch (*Betula pendula*). *J Chem Ecol*, 15, 275-83.
- HEIKKILÄ, L. 2002. Reindeer herding and other traditional means of livelihood in modern context — planning a study in a Sami area in Finland. *Rangifer*, 22, 27-32.
- HEMSLEY, P., HURST, C., KALIYADASA, E., LAMB, R., KNIGHT, M., A DE COTHI, E., STEELE, J. & KNIGHT, H. 2014. *The Arabidopsis mediator complex subunits MED16, MED14, and MED2 regulate mediator and RNA polymerase II recruitment to CBF-responsive cold-regulated genes*.
- HUNDERTMARK, M. & HINCHA, D. K. 2008. LEA (late embryogenesis abundant) proteins and their encoding genes in Arabidopsis thaliana. *BMC genomics*, 9, 118-118.
- INGA, B. & ÖJE, D. 2012. Traditional ecological knowledge among Sami reindeer herders in northern Sweden about vascular plants grazed by reindeer. *Rangifer*, 32, 1-17.
- IPCC WORKING GROUP I 2013. Climate Change 2013 The Physical Science Basis.
- IPCC WORKING GROUP II 2014. Climate Change 2014, Impacts, adaptation, and Vulnerability Part B: Regional Aspects.
- ITO, Y., KATSURA, K., MARUYAMA, K., TAJI, T., KOBAYASHI, M., SEKI, M., SHINOZAKI, K. & YAMAGUCHI-SHINOZAKI, K. 2006. Functional Analysis of Rice DREB1/CBF-type Transcription Factors Involved in Cold-responsive Gene Expression in Transgenic Rice. *Plant and Cell Physiology*, 47, 141-153.
- JACOB, T. R., PERES, N. T. A., PERSINOTI, G. F., SILVA, L. G., MAZUCATO, M., ROSSI, A. & MARTINEZ-ROSSI, N. M. 2012. rpb2 is a reliable reference gene for quantitative gene expression analysis in the dermatophyte *Trichophyton rubrum*. *Medical Mycology*, 50, 368-377.
- JAGLO-OTTOSEN, K. R., GILMOUR, S. J., ZARKA, D. G., SCHABENBERGER, O. & THOMASHOW, M. F. 1998. Arabidopsis CBF1 overexpression induces COR genes and enhances freezing tolerance. *Science*, 280, 104-6.
- JERMY, A., TUTIN, T., AOCHATER, A. & DAVID, R. 1982. *Sedges of the British Isles BSBI Handbook No1*, London, The Botanical Society of the British Isles.
- JU, Y., FENG, L., WU, J., YE, Y., ZHENG, T., CAI, M., CHENG, T., WANG, J., ZHANG, Q. & PAN, H. 2018. Transcriptome analysis of the genes regulating phytohormone and cellular patterning in Lagerstroemia plant architecture. *Scientific Reports*, 8, 15162.

- KALBERER, S. R., WISNIEWSKI, M. & ARORA, R. 2006. Deacclimation and reacclimation of cold-hardy plants: Current understanding and emerging concepts. *Plant Science*, 171, 3-16.
- KAPABIOSYSTEMS 2015. KAPA3G Plant PCR Kit, Technical Data Sheet, version 1.11.
- KENDALL, S., HELLWEGE, A., MARRIOT, P., WHALLEY, C., GRAHAM, I. & PENFIELD, S. 2011. *Induction of Dormancy in Arabidopsis Summer Annuals Requires Parallel Regulation of DOG1 and Hormone Metabolism by Low Temperature and CBF Transcription Factors*.
- KEW, R. 2013. *The Plant List Record: Arabidopsis arenosa* [Online]. Available: <http://www.theplantlist.org/tpl1.1/record/kew-2645201?ref=tpl1> [Accessed 2018].
- KILIAN, J., WHITEHEAD, D., HORAK, J., WANKE, D., WEINL, S., BATISTIC, O., D'ANGELO, C., BORNBERG-BAUER, E., KUDLA, J. & HARTER, K. 2007. The AtGenExpress global stress expression data set: protocols, evaluation and model data analysis of UV-B light, drought and cold stress responses. *Plant J*, 50, 347-63.
- KNIGHT, M. R. & KNIGHT, H. 2012. Low-temperature perception leading to gene expression and cold tolerance in higher plants. *New Phytologist*, 195, 737-751.
- KNOX, A. K., DHILLON, T., CHENG, H., TONDELLI, A., PECCHIONI, N. & STOCKINGER, E. J. 2010. CBF gene copy number variation at Frost Resistance-2 is associated with levels of freezing tolerance in temperate-climate cereals. *Theoretical and Applied Genetics*, 121, 21-35.
- KRON, K. A. 1997. Phylogenetic relationships of Rhododendroideae (Ericaceae). *American Journal of Botany*, 84, 973-980.
- KUME, S., KOBAYASHI, F., ISHIBASHI, M., OHNO, R., NAKAMURA, C. & TAKUMI, S. 2005. Differential and coordinated expression of *Cbf* and *Cor/Lea* genes during long-term cold acclimation in two wheat cultivars showing distinct levels of freezing tolerance. *Genes & Genetic Systems*, 80, 185-197.
- LARKIN, M. A., BLACKSHIELDS, G., BROWN, N. P., CHENNA, R., MCGETTIGAN, P. A., MCWILLIAM, H., VALENTIN, F., WALLACE, I. M., WILM, A., LOPEZ, R., THOMPSON, J. D., GIBSON, T. J. & HIGGINS, D. G. 2007. Clustal W and Clustal X version 2.0. *Bioinformatics*, 23, 2947-2948.
- LEE, B.-H., HENDERSON, D. A. & ZHU, J.-K. 2005. The *Arabidopsis* Cold-Responsive Transcriptome and Its Regulation by ICE1. *The Plant Cell*, 17, 3155.
- LEE, C.-M. & THOMASHOW, M. F. 2012. Photoperiodic regulation of the C-repeat binding factor (CBF) cold acclimation pathway and freezing tolerance in *Arabidopsis thaliana*. *Proceedings of the National Academy of Sciences of the United States of America*, 109, 15054-15059.
- LIU, Q., KASUGA, M., SAKUMA, Y., ABE, H., MIURA, S., YAMAGUCHI-SHINOZAKI, K. & SHINOZAKI, K. 1998. Two Transcription Factors, DREB1 and DREB2, with an EREBP/AP2 DNA Binding Domain Separate Two Cellular Signal Transduction Pathways in Drought- and Low-Temperature-Responsive Gene Expression, Respectively, in *Arabidopsis*. *The Plant Cell*, 10, 1391.
- LIVAK, K. J. & SCHMITTGEN, T. D. 2001. Analysis of relative gene expression data using real-time quantitative PCR and the 2^{(-Delta Delta C(T))} Method. *Methods*, 25, 402-8.
- LUO, Y., DONG, X., YU, T., SHI, X., LI, Z., YANG, W., WIDMER, A. & KARRENBERG, S. 2015. A Single Nucleotide Deletion in Gibberellin20-oxidase1 Causes Alpine Dwarfism in *Arabidopsis*. *Plant Physiol*, 168, 930-7.
- MALTAS, E., VURAL, H. C. & YILDIZ, S. 2011. Extraction of genomic DNA from polysaccharide and phenolics-rich *Ginkgo biloba*. *Journal of Medicinal Plants Research*, 5, 332-339.
- MASE, K., ISHIHAMA, N., MORI, H., TAKAHASHI, H., KAMINAKA, H., KODAMA, M. & YOSHIOKA, H. 2013. Ethylene-responsive AP2/ERF transcription factor MACD1 participates in phytotoxin-triggered programmed cell death. *Mol Plant Microbe Interact*, 26, 868-79.
- MASSEY, J. & SAMUEL, L. 2018. Extreme Cold: The Impact of Cold Weather on Farming. *Climate Fieldview*.
- MATHUR, S., VYAS, S., KAPOOR, S. & TYAGI, A. K. 2011. The Mediator Complex in Plants: Structure, Phylogeny, and Expression Profiling of Representative Genes in a Dicot

- (Arabidopsis) and a Monocot (Rice) during Reproduction and Abiotic Stress. *Plant Physiology*, 157, 1609.
- MCGREGOR, M. *Saxifrages From Seed* [Online]. The Saxifrage Society. Available: <http://www.saxifraga.org/publications/magazine/article1a.htm> [Accessed 2014].
- MCKHANN, H. I., GERY, C., BÉRARD, A., LÉVÊQUE, S., ZUTHER, E., HINCHA, D. K., DE MITA, S., BRUNEL, D. & TÉOULÉ, E. 2008. Natural variation in CBF gene sequence, gene expression and freezing tolerance in the Versailles core collection of Arabidopsis thaliana. *BMC Plant Biology*, 8, 105.
- MCWILLIAM, H., LI, W., ULUDAG, M., SQUIZZATO, S., PARK, Y. M., BUSO, N., COWLEY, A. P. & LOPEZ, R. 2013. Analysis Tool Web Services from the EMBL-EBI. *Nucleic Acids Research*, 41, W597-W600.
- MEDINA, J., BARGUES, M., TEROL, J., PÉREZ-ALONSO, M. & SALINAS, J. 1999. The Arabidopsis CBF gene family is composed of three genes encoding AP2 domain-containing proteins whose expression is regulated by low temperature but not by abscisic acid or dehydration. *Plant physiology*, 119, 463-470.
- MET-OFFICE. 1959-2018. *Braemar Station Data* [Online]. Available: <https://www.metoffice.gov.uk/pub/data/weather/uk/climate/stationdata/braemardata.txt> [Accessed 2018].
- MET-OFFICE. 1981-2010. *Climate Maps* [Online]. Available: <https://www.metoffice.gov.uk/public/weather/climate/> [Accessed 2018].
- MET-OFFICE. 2016. *UK Climate Summaries September 2015* [Online]. Available: <https://www.metoffice.gov.uk/climate/uk/summaries/2015/september> [Accessed 2018].
- MET-OFFICE. 2017. *Mountain Weather* [Online]. Available: <https://www.metoffice.gov.uk/services/mountain/weather> [Accessed 2018].
- MILLER, A. K., GALIBA, G. & DUBCOVSKY, J. 2006. A cluster of 11 CBF transcription factors is located at the frost tolerance locus Fr-Am2 in Triticum monococcum. *Mol Genet Genomics*, 275, 193-203.
- MOFFAT, C. S., INGLE, R. A., WATHUGALA, D. L., SAUNDERS, N. J., KNIGHT, H. & KNIGHT, M. R. 2012. ERF5 and ERF6 play redundant roles as positive regulators of JA/Et-mediated defense against Botrytis cinerea in Arabidopsis. *PLoS One*, 7, e35995.
- MONNI, S., UHLIG, C., HANSEN, E. & MAGEL, E. 2001. Ecophysiological responses of Empetrum nigrum to heavy metal pollution. *Environ Pollut*, 112, 121-9.
- MOORS FOR THE FUTURE PARTNERSHIP. 2019. *Repairing Bare Peat* [Online]. Available: <https://www.moorsforthefuture.org.uk/our-work/restoring-blanket-bog/repairing-bare-peat> [Accessed].
- MORGULIS, A., COULOURIS, G., RAYTSELIS, Y., MADDEN, T. L., AGARWALA, R. & SCHAFFER, A. A. 2008. Database indexing for production MegaBLAST searches. *Bioinformatics*, 24, 1757-64.
- MUHIDIN, SYAM'UN, E., KAIMUDDIN, MUSA, Y., SADIMANTARA, G. R., USMAN, LEOMO, S. & RAKIAN, T. C. 2018. The effect of shade on chlorophyll and anthocyanin content of upland red rice. *IOP Conference Series: Earth and Environmental Science*, 122, 012030.
- NASSUTH, A., SIDDIQUA, M., XIAO, H., MOODY, M. A. & CARLOW, C. E. 2014. Newly developed quantitative transactivation system shows difference in activation by Vitis CBF transcription factors on DRE/CRT elements. *Plant Methods*, 10, 32.
- NCBI 2018. Database resources of the National Center for Biotechnology Information. *Nucleic Acids Res*, 46, D8-d13.
- NEBEL, B. R. 1937. Mechanism of Polyploidy through Colchicine. *Nature*, 140, 1101.
- NEW ENGLAND BIOLABS INC. *Double Digest Finder* [Online]. Available: <https://www.neb.com/tools-and-resources/interactive-tools/double-digest-finder> [Accessed 2015].
- NEWS STAFF. 2012. Ontario fruit crops decimated by frost. *CityNews*.

- NORDIN, K., VAHALA, T. & PALVA, E. T. 1993. Differential expression of two related, low-temperature-induced genes in *Arabidopsis thaliana* (L.) Heynh. *Plant Mol Biol*, 21, 641-53.
- NORTH PENNINES AONB PARTNERSHIP 2019. North Pennines Area of Outstanding Natural Beauty Management Plan 2019-24.
- NORWEGIAN METEOROLOGICAL INSTITUTE AND NORWEGIAN BROADCASTING CORPORATION. 2007-2014. Norwedian records. Available: <http://www.yr.no/place/Norway/rekorder.html?visaar=1#kulderekord> [Accessed].
- NOVILLO, F., ALONSO, J. M., ECKER, J. R. & SALINAS, J. 2004. CBF2/DREB1C is a negative regulator of CBF1/DREB1B and CBF3/DREB1A expression and plays a central role in stress tolerance in *Arabidopsis*. *Proc Natl Acad Sci U S A*, 101, 3985-90.
- OAKENFULL, R. J., BAXTER, R. & KNIGHT, M. R. 2013. A C-Repeat Binding Factor Transcriptional Activator (CBF/DREB1) from European Bilberry (*Vaccinium myrtillus*) Induces Freezing Tolerance When Expressed in *Arabidopsis thaliana*. *PLOS ONE*, 8, e54119.
- ODASZ, A. M. 1990. Freezing resistance of arctic tundra plants on Svalbard. *58th Annual Western Snow Conference*. Sacramento, California: Western Snow Conference.
- OLSEN, K., XA, M., UNGERER, M., XA & C 2008. Freezing Tolerance and Cyanogenesis in White Clover (*Trifolium repens* L. Fabaceae). *International Journal of Plant Sciences*, 169, 1141-1147.
- PARISOD, C., HOLDEREGGER, R. & BROCHMANN, C. 2010. Evolutionary consequences of autopolyploidy. *New Phytologist*, 186, 5-17.
- PARK, B. 2018. FROST BITES: Valencia region suffers '€35 million in crop losses' due to weather. *EuroWeekly*.
- PATERSON, A., BRUBAKER, C. & WENDEL, J. 1993. A rapid method for extraction of cotton (*Gossypium* spp.) genomic DNA suitable for RFLP or PCR analysis. *Plant Molecular Biology Reporter*, 11, 122-127.
- PETOUKHOV, V. & SEMENOV, V. A. 2010. A link between reduced Barents-Kara sea ice and cold winter extremes over northern continents. *Journal of Geophysical Research: Atmospheres*, 115.
- PHILLIPS, T. 2013. *The Coldest Place in the World* [Online]. NASA. Available: http://science.nasa.gov/science-news/science-at-nasa/2013/09dec_coldspot/ [Accessed 14/04/2015 2015].
- PINO, M.-T., SKINNER, J. S., PARK, E.-J., JEKNIĆ, Z., HAYES, P. M., THOMASHOW, M. F. & CHEN, T. H. H. 2007. Use of a stress inducible promoter to drive ectopic AtCBF expression improves potato freezing tolerance while minimizing negative effects on tuber yield. *Plant Biotechnology Journal*, 5, 591-604.
- POLAND, J. & CLEMENT, E. 2009. *The Vegetative Key to the British Flora*, Southampton, ohn Poland in association with the Botanical Society of the British Isles.
- POPP, M., MIRRÉ, V. & BROCHMANN, C. 2011. A single Mid-Pleistocene long-distance dispersal by a bird can explain the extreme bipolar disjunction in crowberries (*Empetrum*). *Proceedings of the National Academy of Sciences*, 108, 6520-6525.
- PTASHNE, M. 1988. How eukaryotic transcriptional activators work. *Nature*, 335, 683.
- R CORE TEAM. 2014. *R: A language and environment for statistical computing*. R Foundation for Statistical Computing, Vienna, Austria. [Online]. Available: <http://www.R-project.org/> [Accessed].
- RÄISÄNEN, J. & EKLUND, J. 2012. *Northern Europe: a high-resolution view from ENSEMBLES regional climate models*. *Clim Dyn*.
- RBG EDINBURGH. 2018a. *Catalogue of the Living collections: RBGE Accession number 19401013* [Online]. Available: http://data.rbge.org.uk/search/livingcollection/?cfg=allacc.cfg&acc_num=19401013 [Accessed 2018].
- RBG EDINBURGH. 2018b. *Catalogue of the Living collections: RBGE Accession number 19721433* [Online]. Available: [Data.rbge.org.uk/living/19721433](http://data.rbge.org.uk/living/19721433) [Accessed 2018].

- RHS. *Gentiana verna* [Online]. Available: <https://www.rhs.org.uk/plants/details?plantid=4476> [Accessed 2014].
- RICH, T., CORNER, R. & SWAN, G. 1992. *Plant Crib; Empetrum nigrum*, Botanical Society of the British Isles.
- RIVERO, R. M., RUIZ, J. M., GARCIA, P. C., LOPEZ-LEFEBRE, L. R., SANCHEZ, E. & ROMERO, L. 2001. Resistance to cold and heat stress: accumulation of phenolic compounds in tomato and watermelon plants. *Plant Sci*, 160, 315-321.
- RIXEN, C., DAWES, M. A., WIPF, S. & HAGEDORN, F. 2012. Evidence of enhanced freezing damage in treeline plants during six years of CO₂ enrichment and soil warming. *Oikos*, 121, 1532-1543.
- ROSE, F. 1989. *Colour Identification Guide to the Grasses, Sedges, Rushes and Ferns of the British Isles and North-Western Europe*, London, The Penguin Group.
- ROSE, F. 2006. *The Wildflower Key (2nd ed.) Revised and updated by: O'Reilly, C.*, London, Frederick Warne.
- SÆBØ, A., HÅLAND, Å., SKRE, O. & MORTENSEN, L. M. 2001. Influence of Nitrogen and Winter Climate Stresses on *Calluna vulgaris*(L.) Hull. *Annals of Botany*, 88, 823-828.
- SAKUMA, Y., LIU, Q., DUBOUZET, J. G., ABE, H., SHINOZAKI, K. & YAMAGUCHI-SHINOZAKI, K. 2002. DNA-binding specificity of the ERF/AP2 domain of Arabidopsis DREBs, transcription factors involved in dehydration- and cold-inducible gene expression. *Biochem Biophys Res Commun*, 290, 998-1009.
- SCHRADER, C., SCHIELKE, A., ELLERBROEK, L. & JOHNE, R. 2012. PCR inhibitors – occurrence, properties and removal. *Journal of Applied Microbiology*, 113, 1014-1026.
- SEEDAHOLIC.COM. *Dianthus superbis* [Online]. Available: <https://www.seedaholic.com/dianthus-superbus.html> [Accessed 2014].
- SEMERDJIEVA, S. I., SHEFFIELD, E., PHOENIX, G. K., GWYNN-JONES, D., CALLAGHAN, T. V. & JOHNSON, G. N. 2003. Contrasting strategies for UV-B screening in sub-Arctic dwarf shrubs. *Plant Cell Environ*, 26, 957-964.
- SHABBAR, A. & BONSAI, B. 2003. An Assessment of Changes in Winter Cold and Warm Spells over Canada. *Natural Hazards*, 29, 173-188.
- SHAO, Q., WANG, H., GUO, H., ZHOU, A., HUANG, Y., SUN, Y. & LI, M. 2014. Effects of Shade Treatments on Photosynthetic Characteristics, Chloroplast Ultrastructure, and Physiology of *Anoectochilus roxburghii*. *PLOS ONE*, 9, e85996.
- SIMON, T. W., BUDINSKY, R. A. & ROWLANDS, J. C. 2015. A Model for Aryl Hydrocarbon Receptor-Activated Gene Expression Shows Potency and Efficacy Changes and Predicts Squelching Due to Competition for Transcription Co-Activators. *PLOS ONE*, 10, e0127952.
- SKINNER, J. S., VON ZITZEWITZ, J., SZÚCS, P., MARQUEZ-CEDILLO, L., FILICHKIN, T., AMUNDSEN, K., STOCKINGER, E. J., THOMASHOW, M. F., CHEN, T. H. H. & HAYES, P. M. 2005. Structural, Functional, and Phylogenetic Characterization of a Large CBF Gene Family in Barley. *Plant Molecular Biology*, 59, 533-551.
- STAGGENBORG, S., DHUYVETTER, K., FJELL, D. & VANDERLIP, R. 1996. *Fall Freeze Damage in Summer Crops*, Kansas State University.
- STENBERG, L. & MOSSBERG, B. 2006. *Svensk Fältflora*, Värnamo, Wahlström & Widstrand.
- STOCKINGER, E. J., GILMOUR, S. J. & THOMASHOW, M. F. 1997. Arabidopsis thaliana CBF1 encodes an AP2 domain-containing transcriptional activator that binds to the C-repeat/DRE, a cis-acting DNA regulatory element that stimulates transcription in response to low temperature and water deficit. *Proceedings of the National Academy of Sciences of the United States of America*, 94, 1035-1040.
- STRASSMANN, M. 2017. Crops Fall Victim to Winter 2017's Drastic Temperature Swings. *CBS News*.
- STUSHNOFF, C. & JUNTILLA, O. 1986. Seasonal development of cold stress resistance in several plant species at a coastal and a continental location in North Norway. *Polar Biology*, 5, 129-133.

- SUDA, J. 2002. New DNA ploidy level in *Empetrum* (Empetraceae) revealed by flow cytometry. *Annales Botanici Fennici*, 39, 133-141.
- SUDA, J., MALCOVÁ, R., ABAZID, D., BANAŠ, M., PROCHÁZKA, F., ŠÍDA, O. & ŠTECH, M. 2004. Cytotype distribution in *Empetrum* (Ericaceae) at various spatial scales in the Czech Republic. *Folia Geobotanica*, 39, 161-171.
- SUO, H., MA, Q., YE, K., YANG, C., TANG, Y., HAO, J., ZHANG, Z. J., CHEN, M., FENG, Y. & NIAN, H. 2012. Overexpression of AtDREB1A Causes a Severe Dwarf Phenotype by Decreasing Endogenous Gibberellin Levels in Soybean [*Glycine max* (L.) Merr.]. *PLOS ONE*, 7, e45568.
- SVENNING, M. M., RØSNES, K., LUND, L. & JUNTILA, O. 2001. Vegetative Growth and Freezing Tolerance of White Clover (*Trifolium repens* L.) Genotypes from Svalbard. *Acta Agriculturae Scandinavica, Section B — Soil & Plant Science*, 51, 10-16.
- SVENSSON, J. T., CROSATTI, C., CAMPOLI, C., BASSI, R., STANCA, A. M., CLOSE, T. J. & CATTIVELLI, L. 2006. Transcriptome Analysis of Cold Acclimation in Barley Albina and Xantha Mutants. *Plant Physiology*, 141, 257.
- TAIR. 2018. *Locus: AT4G21710* [Online]. Available: <https://www.arabidopsis.org/servlets/TairObject?name=AT4G21710&type=locus> [Accessed 2018].
- TAKUMI, S., SHIMAMURA, C. & KOBAYASHI, F. 2008. Increased freezing tolerance through up-regulation of downstream genes via the wheat CBF gene in transgenic tobacco. *Plant Physiology and Biochemistry*, 46, 205-211.
- TAYEH, N., BAHRMAN, N., SELIER, H., BLUTEAU, A., BLASSIAU, C., FOURMENT, J., BELLEC, A., DEBELLÉ, F., LEJEUNE-HÉNAUT, I. & DELBREIL, B. 2013. A tandem array of CBF/DREB1 genes is located in a major freezing tolerance QTL region on Medicago truncatula chromosome 6. *BMC genomics*, 14, 814-814.
- THE LOCAL. 2017. Swiss authorities look to help farmers after ‘frost of the century’ wiped out crops. *The Local ch*.
- THERMOFISHER. 2018a. *Amplification of the No Template Control (NTC)* [Online]. Available: <https://www.thermofisher.com/uk/en/home/life-science/pcr/real-time-pcr/real-time-pcr-learning-center/real-time-pcr-basics/real-time-pcr-troubleshooting-tool/gene-expression-quantitation-troubleshooting/amplification-no-template-control.html> [Accessed 2018].
- THERMOFISHER. 2018b. *TaqMan vs. SYBR Chemistry for Real-Time PCR* [Online]. Available: <https://www.thermofisher.com/uk/en/home/life-science/pcr/real-time-pcr/real-time-pcr-learning-center/real-time-pcr-basics/taqman-vs-sybr-chemistry-real-time-pcr.html> [Accessed 2018].
- THOMASHOW, M. F., GILMOUR, S. J., STOCKINGER, E. J., JAGLO-OTTOSEN, K. R. & ZARKA, D. G. 2001. Role of the Arabidopsis CBF transcriptional activators in cold acclimation. *Physiologia Plantarum*, 112, 171-175.
- TYLER, L., THOMAS, S. G., HU, J., DILL, A., ALONSO, J. M., ECKER, J. R. & SUN, T.-P. 2004. DELLA Proteins and Gibberellin-Regulated Seed Germination and Floral Development in Arabidopsis. *Plant Physiology*, 135, 1008.
- UNITES STATES DEPARTMENT OF AGRICULTURE. 2018. *USDA Plant Hardiness Zone Map* [Online]. Available: <https://planthardiness.ars.usda.gov/> [Accessed 2018].
- UPADHYAY, A., MASKE, S., JOGIAH, S., KADOO, N. Y. & GUPTA, V. S. 2018. GA3 application in grapes (*Vitis vinifera* L.) modulates different sets of genes at cluster emergence, full bloom, and berry stage as revealed by RNA sequence-based transcriptome analysis. *Funct Integr Genomics*, 18, 439-455.
- UPWARD, M. *Gentiana (Spring Flowering)* [Online]. Alpine Garden Society. Available: <http://www.alpinegardensociety.net/plants/plant-portraits/Gentiana+Spring+flowering/68/> [Accessed 2014].
- WANG, H., DATLA, R., GEORGES, F., LOEWEN, M. & CUTLER, A. J. 1995. Promoters from kin1 and cor6.6, two homologous Arabidopsis thaliana genes: transcriptional regulation and

- gene expression induced by low temperature, ABA, osmoticum and dehydration. *Plant Molecular Biology*, 28, 605-617.
- WANG, X.-C., ZHAO, Q.-Y., MA, C.-L., ZHANG, Z.-H., CAO, H.-L., KONG, Y.-M., YUE, C., HAO, X.-Y., CHEN, L., MA, J.-Q., JIN, J.-Q., LI, X. & YANG, Y.-J. 2013. Global transcriptome profiles of *Camellia sinensis* during cold acclimation. *BMC Genomics*, 14, 415.
- WANG, Z., TRIEZENBERG, S., THOMASHOW, M. & STOCKINGER, E. 2005. Multiple hydrophobic motifs in Arabidopsis CBF1 COOH-terminus provide functional redundancy in trans-activation. *Plant Molecular Biology*, 58, 543-559.
- WATERHOUSE, A. M., PROCTER, J. B., MARTIN, D. M. A., CLAMP, M. & BARTON, G. J. 2009. Jalview Version 2—a multiple sequence alignment editor and analysis workbench. *Bioinformatics*, 25, 1189-1191.
- WEATHERONLINE. 1999-2018. *Aviemoire* [Online]. Available: <https://www.weatheronline.co.uk/weather/maps/city?LANG=en&WMO=03063&ART=MIN&CONT=ukuk&R=150&LEVEL=150®ION=0003&LAND=&NOREGION=0&MOD=&TMX=&TMN=&SON=&PRE=&MONAT=&OFFS=&SORT=> [Accessed 2018].
- WELLING, A. & PALVA, E. T. 2008. Involvement of CBF transcription factors in winter hardiness in birch. *Plant Physiol*, 147, 1199-211.
- WHEELER, J. A., HOCH, G., CORTÉS, A. J., SEDLACEK, J., WIPF, S. & RIXEN, C. 2014. Increased spring freezing vulnerability for alpine shrubs under early snowmelt. *Oecologia*, 175, 219-229.
- WINFIELD, M. O., LU, C., WILSON, I. D., COGHILL, J. A. & EDWARDS, K. J. 2010. Plant responses to cold: transcriptome analysis of wheat. *Plant Biotechnology Journal*, 8, 749-771.
- WINTER, D., VINEGAR, B., NAHAL, H., AMMAR, R., WILSON, G. V. & PROVART, N. J. 2007. An “Electronic Fluorescent Pictograph” Browser for Exploring and Analyzing Large-Scale Biological Data Sets. *PLOS ONE*, 2, e718.
- WISNIEWSKI, M., NORELLI, J., BASSETT, C., ARTLIP, T. & MACARISIN, D. 2011. Ectopic expression of a novel peach (*Prunus persica*) CBF transcription factor in apple (*Malus × domestica*) results in short-day induced dormancy and increased cold hardiness. *Planta*, 233, 971-983.
- WURSCHUM, T., LONGIN, C. F., HAHN, V., TUCKER, M. R. & LEISER, W. L. 2017. Copy number variations of CBF genes at the Fr-A2 locus are essential components of winter hardiness in wheat. *Plant J*, 89, 764-773.
- XIAO, H., TATTERSALL, E. A. R., SIDDIQUA, M. K., CRAMER, G. R. & NASSUTH, A. 2008. CBF4 is a unique member of the CBF transcription factor family of *Vitis vinifera* and *Vitis riparia*. *Plant, Cell & Environment*, 31, 1-10.
- XIE, J., TIAN, J., DU, Q., CHEN, J., LI, Y., YANG, X., LI, B. & ZHANG, D. 2016. Association genetics and transcriptome analysis reveal a gibberellin-responsive pathway involved in regulating photosynthesis. *J Exp Bot*, 67, 3325-38.
- XIONG, Y. & FEI, S.-Z. 2006. Functional and phylogenetic analysis of a DREB/CBF-like gene in perennial ryegrass (*Lolium perenne* L.). *Planta*, 224, 878-888.
- YAMAGUCHI-SHINOZAKI, K. & SHINOZAKI, K. 1994. A novel cis-acting element in an Arabidopsis gene is involved in responsiveness to drought, low-temperature, or high-salt stress. *The Plant Cell*, 6, 251.
- YAMORI, W., KOGAMI, H. & MASUZAWA, T. 2005. Freezing tolerance in alpine plants as assessed by the FDA-staining method. *Polar bioscience*, 18, 73-81.
- YANG, Y.-W., LAI, K.-N., TAI, P.-Y., MA, D.-P. & LI, W.-H. 1999. Molecular Phylogenetic Studies of Brassica, Rorippa, Arabidopsis and Allied Genera Based on the Internal Transcribed Spacer Region of 18S–25S rDNA. *Molecular Phylogenetics and Evolution*, 13, 455-462.
- ZARKA, D. G., VOGEL, J. T., COOK, D. & THOMASHOW, M. F. 2003. Cold induction of Arabidopsis CBF genes involves multiple ICE (inducer of CBF expression) promoter elements and a cold-regulatory circuit that is desensitized by low temperature. *Plant Physiol*, 133, 910-8.
- ZHANG, X., FOWLER, S. G., CHENG, H., LOU, Y., RHEE, S. Y., STOCKINGER, E. J. & THOMASHOW, M. F. 2004. Freezing-sensitive tomato has a functional CBF cold response pathway, but

- a CBF regulon that differs from that of freezing-tolerant Arabidopsis. *The Plant Journal*, 39, 905-919.
- ZHAO, C., ZHANG, Z., XIE, S., SI, T., LI, Y. & ZHU, J.-K. 2016. Mutational Evidence for the Critical Role of CBF Transcription Factors in Cold Acclimation in Arabidopsis. *Plant physiology*, 171, 2744-2759.
- ZUTHER, E., JUSZCZAK, I., LEE, Y. P., BAIER, M. & HINCHA, D. K. 2015. Time-dependent deacclimation after cold acclimation in Arabidopsis thaliana accessions. *Scientific reports*, 5, 12199-12199.