



Durham E-Theses

Measurements of precipitation electricity

Merry, G. H.

How to cite:

Merry, G. H. (1959) *Measurements of precipitation electricity*, Durham theses, Durham University.
Available at Durham E-Theses Online: <http://etheses.dur.ac.uk/10396/>

Use policy

The full-text may be used and/or reproduced, and given to third parties in any format or medium, without prior permission or charge, for personal research or study, educational, or not-for-profit purposes provided that:

- a full bibliographic reference is made to the original source
- a [link](#) is made to the metadata record in Durham E-Theses
- the full-text is not changed in any way

The full-text must not be sold in any format or medium without the formal permission of the copyright holders.

Please consult the [full Durham E-Theses policy](#) for further details.

"Measurements of Precipitation Electricity"

by

G.H. Merry, B.Sc.

Submitted in candidature for the degree of
Master of Science in the University of Durham.

December, 1959.



CONTENTS

	<u>Page</u>
Abstract	
Chapter I Historical Introduction	
1.1 General	1
1.2 A present-day picture	3
1.3 Previous Measurements on Precipitation Current	6
Chapter II Apparatus. Design and Construction	
2.1 The Rain Collector	10
2.2 The Field Mills	13
2.3 Recording	15
2.4 The Vibrating Reed Electrometer	16
2.5 Amplifiers	16
2.6 Other Apparatus	17
Chapter III Calibration and Performance of Equipment	
3.1 Field Mills	19
3.2 Vibrating Reed Electrometer	22
3.3 The Upper Mill	25
Chapter IV Results and Discussion	27
Suggestions for Further Work	32
Appendix	34
Acknowledgments	35
References	36

ABSTRACT

Early workers in Atmospheric Electricity, found that in steady continuous rain, when fields were in the range ± 400 V/m., the Potential Gradients at the top and bottom of a high mast were positive and negative, respectively, giving a charge at top and bottom of negative and positive. This indicates the presence of negative space charge in the layers of air between the ground and the top of the mast. As yet this phenomena has received no satisfactory explanation and the problem in hand was to investigate the origin of this negative space charge.

The proposed idea was to measure precipitation currents at the ground and at various heights above the ground, using a 30 metre mast, situated in a field adjoining Durham Observatory. Simultaneous measurements of Potential Gradient would serve to show the height to which the space charge extended.

Shielded rain collectors were situated at ground level and at 30 metres above the ground together with Field Mills for Potential Gradient measurements. Precipitation currents and Field changes were recorded photographically by connecting the respective outputs to four mirror galvanometers. The Field Mill amplifiers and a monitoring panel were situated in a separate room at the Observatory.

Unfortunately, once all the apparatus was in working order, only two periods of suitable conditions arose. The results so obtained could not possibly give any conclusive evidence in view of the small number of readings taken. A large difference in value of the Precipitation Currents at the two levels was observed, and is discussed in Chapter IV. Potential Gradient signs and values were much as expected from previous workers' results.

CHAPTER I

Historical Introduction

1.1 General.

The earliest reference to the idea of electricity existing in the air, appears to be that of Wall (1708), who observed a flash when amber was held a short distance from his finger, and who went so far as to liken it to a lightning flash. Winkler (1746) went a stage further and suggested that the origin of the electricity in the atmosphere was due to the friction of the particles existing there.

The first determination of sign of charge received from the thunder cloud however was made by Franklin (1752). He stored the charge received from a number of elevated points beneath a thunder cloud, in Leyden Jars, and compared its sign with that of an artificially produced charge.

Lemonnier (1752) originally observed fine weather effects, and although he suspected the existence of daily variations in the atmospheric electric parameters, it was left to Beccaria (1775) to confirm that these variations actually occurred. Beccaria also observed for the first time, the difference in sign of charge received in disturbed and fine weather. The first to confirm that there was an



annual variation in the magnitude of atmospheric electric effects was De Saussure (1779), and perhaps his greatest contribution to the subject was measurements he made with his moveable plate. This really can be considered as the original of many present day methods of measuring potential gradient.

These early workers accounted for the effects observed by supposing the atmosphere to carry a positive space charge, increasing with height above the ground. Volta (1800) provided an explanation of its origin by saying that the change of state of water from liquid to vapour, was accompanied by a separation of charge. He further said that some positive charge as well as latent heat was necessary for this conversion, and hence the earth would have a negative charge; the first time its existence had been recognised.

Many workers following Volta made very important contributions, but those of Kelvin (1859-60), mainly his advances in the theory of electrostatics, and his application of them to Atmospheric Electricity, appear to be the next big step forward in the subject. Apart from perfecting an electrometer more sensitive than anything then in use,

he also introduced the important concept of potential, and said that positive charges associated with the negative charge on the earth's surface must be inside the conducting region of the higher atmosphere.

Earlier workers had established that air was conducting but it was left to Linss (1887), to estimate that at the rate the charge leaked away from the earth, the total on any one portion of the earth's surface would leak away entirely in a period of approximately 10 minutes. This brings us to what is still the fundamental problem in the subject, viz: How is the negative charge on the earth maintained?

1.2 A present-day picture.

Recent advances in the use of radio techniques have helped to solve many difficult problems in the scientific field generally, and in no small measure, have contributed to a clearer understanding of the problems of Atmospheric Electricity. Radio wave reflections from points in the earth's atmosphere, have shown that at heights of 100 kms. and more, there is a highly ionised region, split into different layers and completely surrounding the earth. It has been known for quite a long time, that air is a conductor

but for the purposes of Atmospheric Electricity, the region above 50-60 kms. can be considered as a good conductor. The name Ionosphere has been allotted to this region, but for radio wave reflections it is considerably higher.

The zero of potential in Atmospheric Electricity is taken as the earth, although this is not strictly true because it carries a surface charge. Since, however, all formulae in the subject are concerned with differences and not absolute values, it serves as a convenient choice. Now the rate of change of Potential with distance $\frac{dV}{dx}$ gives the force acting on a body, such that the body with positive charge moves to a region of lower potential. Also, the ratio of the force acting on the body to the charge it possesses gives the electric field strength E, in Newtons/Coulomb.

$$E = - \frac{dV}{dx}$$

Where $\frac{dV}{dx}$ is the Potential Gradient in volts/metre.

In fine weather there is a positive potential gradient, and positive charge is brought down by conduction to the earth's surface, enough as was shown by Scrases (1933) measurements of Air-Earth current, to neutralise the charge on 1 square metre of the earth's surface in 48 minutes.

This, however, does not happen and it is now generally agreed that the earth's negative charge is maintained in those regions of the world experiencing bad or disturbed weather. As stated before, the potential gradient in fine weather is positive, i.e. the potential rises on rising in the atmosphere, thus making the Ionosphere positive with respect to the earth. Calculations show this value to lie between 3 to 4 x 10⁵V.

Several workers have calculated an electrical balance sheet, and it is generally agreed that the main carriers of charge to earth are in fine weather conduction current, and in disturbed weather precipitation, lightning, and point discharge current. Measurement of any one of these four processes, then could add to the picture already obtained of the conditions existing in our atmosphere, and in the case of the latter three, to the processes of charge separation occurring in clouds. Since either water droplets or ice particles are the vehicles by which this separation is effected, measurement of precipitation currents at the earth's surface, or at different levels in the earth's atmosphere, would appear to be a good starting point in trying to understand the separation process.

1.3 Previous Measurements on Precipitation Current.

The first suggestion that the charge carried on rain should be measured, appears to have been made by Kelvin (1860), but the first experiments of this nature were carried out by Ekster and Goitel (1888) using one of the two methods generally used for precipitation current measurements. Their instrument consisted of a collector for catching the rain, insulated, and connected to a measuring device, and surrounded by an earthed shield to prevent changes in Potential Gradient affecting the readings. The other form of collector is completely exposed, and although it registers the total precipitation current unlike the first form which may miss small wind borne drops, it also registers currents due to changing bound charge. Measurements using an exposed type receiver were made by Weiss (1906) using a wire brush, and Herath (1914) using a large expanse of suspended cloth. Wilson (1916) suggested making conditions more nearly natural, by surrounding and covering the collector with soil or grass. More recently Adamson (1959) using this method has compensated for Potential Gradient Changes.

Using a method similar to that of Elster and Geitel, Simpson (1909), Kahler (1908) and Baldit (1910), all found

an excess of positive charge. Benndorf (1908-10) first observed what is referred to as the mirror image effect and is a simultaneous increase or decrease of rain current and potential gradient but in opposite senses. Scrase (1938) and Simpson (1949) using essentially the same apparatus, made continuous recordings over a period of time, and hence were able to give instantaneous values as well as averages, unlike all the earlier workers. One serious disadvantage with their apparatus was the fact that the tipping bucket arrangement was not in electrical connection with the collector, and drops leaving the collector will carry charge away with them. This will tend to reduce the final value of the rain current.

Every one of the methods mentioned so far entails making measurements at ground level, but Kelvin (1860) and Chauveau (1900) made measurements of Potential Gradient at different heights in the atmosphere using towers. In the case of Chauveau it was the Eiffel Tower. More recently Gunn (1950) has made precipitation measurements from an aircraft actually flying in, above, and below cloud.

Both Kelvin and Chauveau found that in steady rain conditions, the potential gradient at the ground is usually negative, but at the top of their respective towers, it

often remained positive. This means in other words that the charge on the earth's surface is positive, but on the surface at the top of the mast is negative. Hence there must be a negative space charge between the top and bottom of the tower, and there arises the problem of the origin of this space charge. Two explanations so far put forward are:-

1. The splashing of the rain drops at the earth's surface releases a negative charge to the air, leaving the drops with a positive charge. This is the Lenard effect.
2. The drops of water break in gusts of wind near to the earth. Recent work has shown, however, that drops 4 mms. diameter are exceptionally stable and for rupture to occur must be subjected to great disturbing forces.

A further explanation suggested by Adkins (1959) said that possibly the precipitation was snow at the top of the mast and that it melted on the way down giving rise to the observed effect. In Chauveau's original paper, however, he says the effect was observed many times, and it seems unlikely that he would have omitted to make reference to this fact if it had been so.

The present work is directed towards finding an explanation of this effect by taking simultaneous readings of rain current and potential gradient at the top and bottom of a mast 34 metres high, situated adjacent to Durham Observatory.

CHAPTER II

Apparatus. Design and Construction.

2.1 The Rain Collectors.

The following chapter deals with the construction of the apparatus, the difficulties encountered during trial runs, and the modifications made as a consequence.

The Rain Collectors were constructed after a design by Scrase (1938), with slight modifications to suit the auxiliary apparatus used by the present worker. They each consist of an earthed outer shield, cylindrical in shape, and an inner conical shield as shown in FIGURE 1. This shielding was essential in the case of the upper collector, to guard against field changes at the top of the mast. Here, of course, the Potential Gradient was very great due to the concentration of lines of force on the earthed mast. Although the concentration of lines of force at the bottom collector was not nearly as great, it was constructed on exactly the same lines so that the area over which the rain was collected was the same. Beneath the conical shield, and supported on Polystyrene insulators, was a funnel for actually collecting the rain, and this was connected by a short piece of co-axial cable to the head unit of a Vibrating Reed Electrometer. Initially it was intended to

have the head unit and collector separated by about two feet, but it was found that very small vibrations and movements of the connecting cable, gave large deflections on the galvanometer connected to the output. This was attributed to the polystyrene insulation of the cable acquiring induced charges. Eventually the Head Unit was bolted to the outer shield thus making the connecting wire much shorter, completely enclosed and, in effect, rigid, hence eliminating the large zero deflections.

The angle θ shown in FIGURE 1 was arranged so that the opening was the same as that of a standard rain gauge. This meant that the outer shield was smaller than that required for complete shielding from Potential Gradient changes, but since these changes would have to be quite large, any such effect could immediately be seen by comparing the Field Mill and Collector traces on the record.

To prevent splashing inside the collector, earth was placed over the top of a piece of gauze which was connected to the funnel. There were spurious effects caused by drops splashing on the rim of the conical shield and small ions produced either falling into or diffusing out of the collector. Investigations by Simpson and Scrase (1937) however showed that the effect of this splashing was not a

The Shielded Collector

FIG: 1

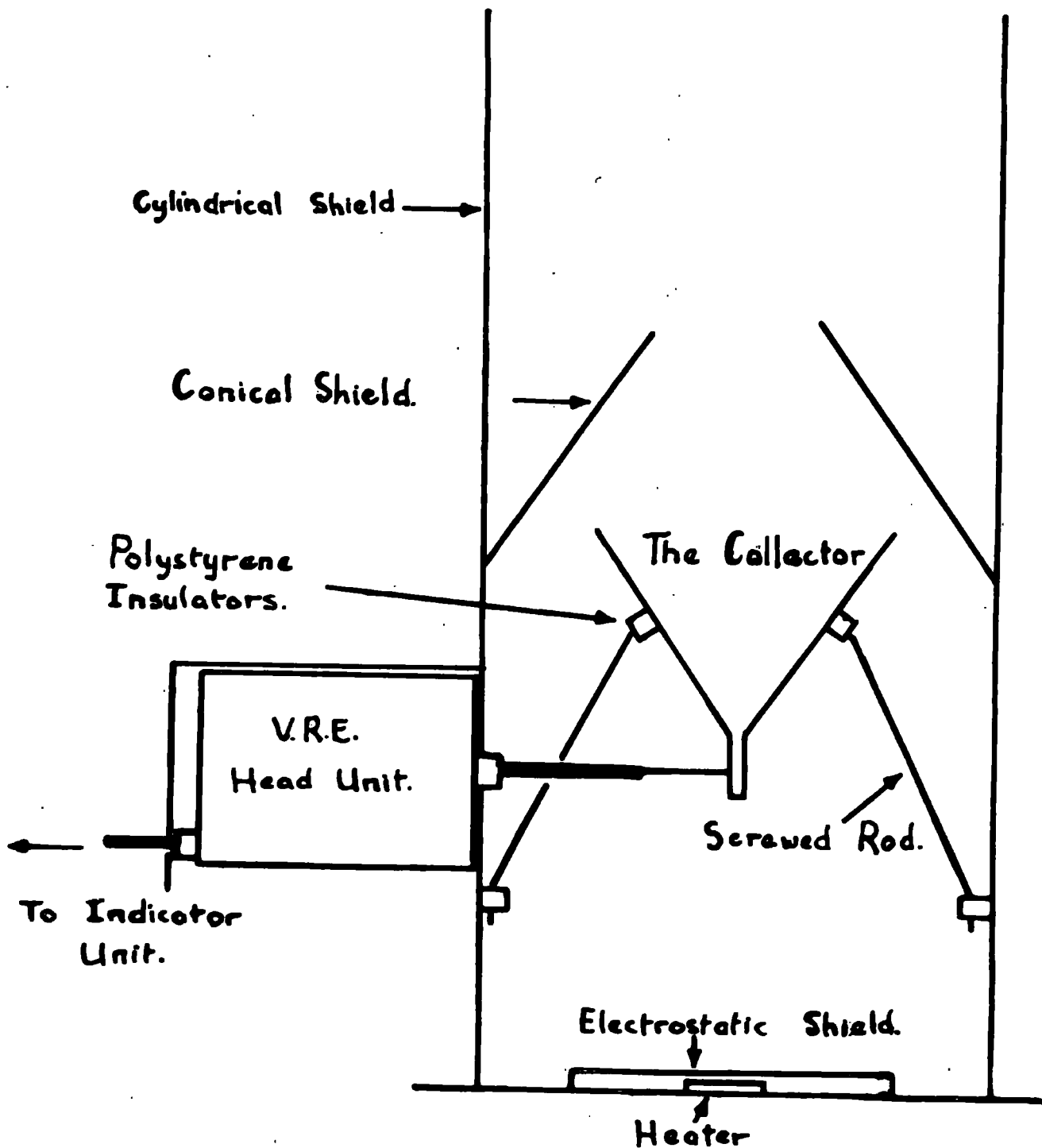

contributing factor in the Rain Current-Potential Gradient relationship.

As both collectors were permanently situated in the open, insulation breakdown was a major problem. Without effective heating, the polystyrene insulators became coated with a layer of moisture in humid conditions, and the resistance to earth became less than the required 10^{10} ohms. This was the value of the input resistor in the head unit. Eventually a method of heating was devised which proved effective under conditions of steady continuous rain, but not in heavy showers. It consisted of a 60 watt mains heating element, electrostatically screened and fitted to a circular piece of aluminium which closed the bottom end of the collector. The only way of completely removing spiders webs, another constant source of trouble where insulation breakdown is concerned, was to run a piece of wire around the inside of the collector before taking a record.

The Electrometer indicator units were situated at the foot of the mast, in a weather proof box. Signals were fed to them from the head unit, by lengths of co-axial cable, and once amplified and rectified, the output was suitable to apply direct to a mirror galvanometer for photographic recording. The units were each fitted with

a built in sensitivity switch, only the two most sensitive ranges ever being used. A 0-30 mv., 0-100 mv. meter, fitted with a reversing switch for negative inputs, enabled the observer to monitor the signal from time to time and hence use the appropriate sensitivity range.

2.2 The Field Mills

The field measuring apparatus available at the observatory when the present work commenced, consisted of four field mills, their power supplies and their amplifiers. The power supplies for the field mill head units, were situated in a weather proof shelter approximately 75 feet from the point at which the mill was to be used. All leads including 200V. H.T., 30V. D.C., and return leads for signal and reference voltage were contained in a six core cable. When first operated, a large zero output from the mill was detected, together with a great deal of mains "pick up". The zero output was originating at the Cathode Follower in the head unit, and the "pick up" was due to inefficient screening in the six core cable.

New Cathode Followers using Mullard 12AT7 valves, and housed in separate boxes were constructed, but proved to be only slightly better than the original ones. Finally,

Cathode Follower Units

FIG: 2.

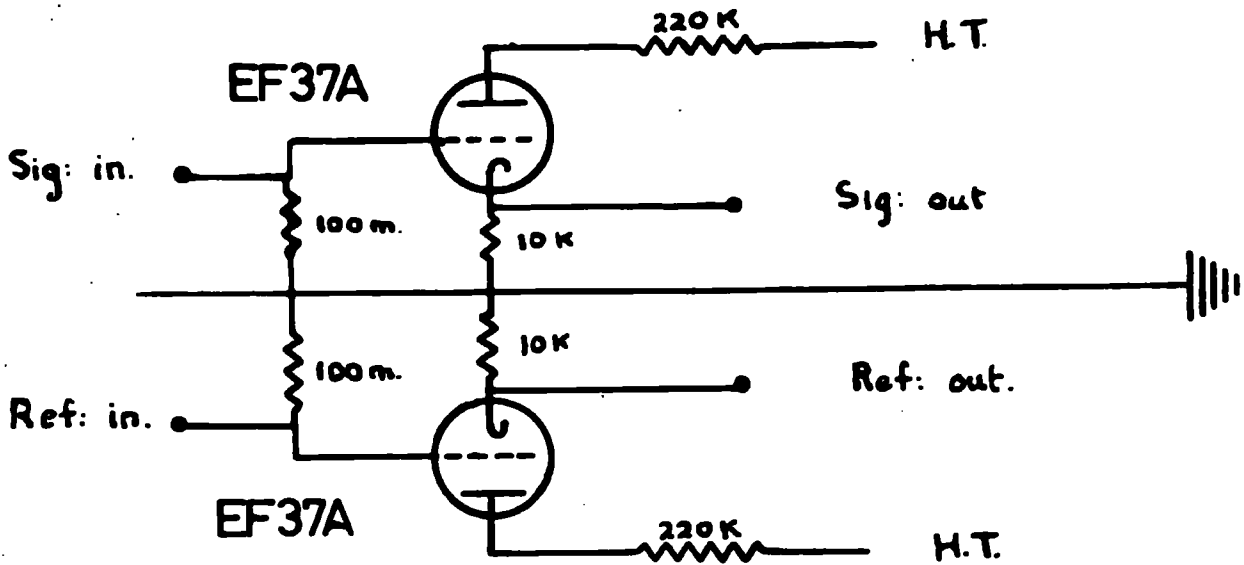

For High Fields

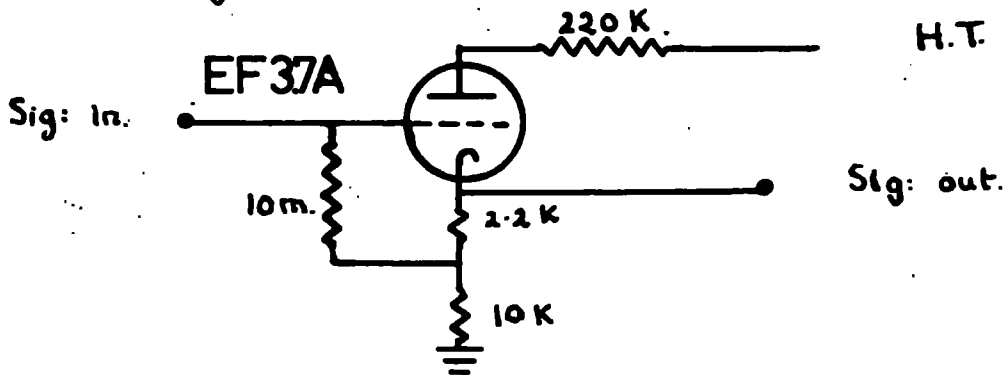

Mill Power Unit

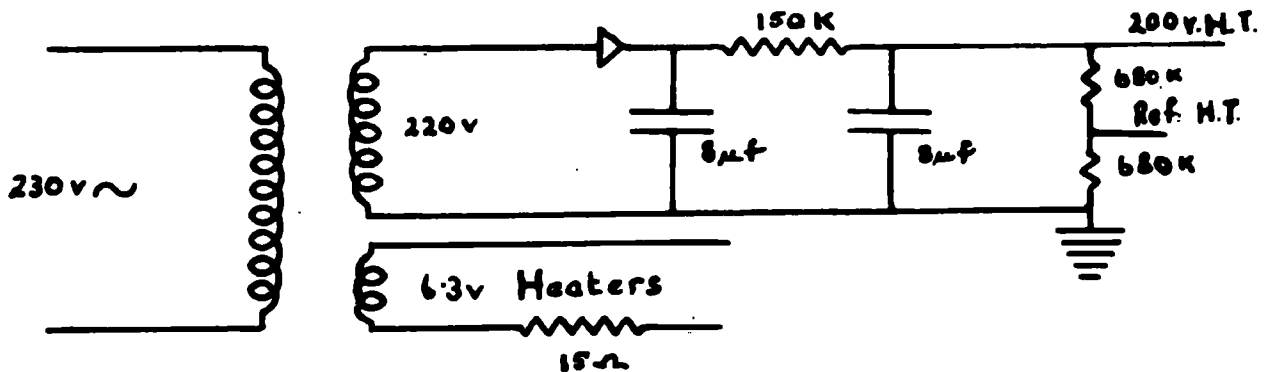

after many different circuits had been constructed and tested, the one shown in FIGURE 2 was chosen and housed in the head unit. The EF37A pentode valve proved efficient, and the Cathode Followers gave a zero output of 2 mv. This after amplification together with the zero output of the amplifier gave a total zero output corresponding to a field of 15 volts/metre. This value stayed remarkably constant, as check calibrations showed at later stages.

Two power leads, one carrying 30V. D.C. for the mill motor, and another carrying 250V. A.C. were necessary to operate the mill. The H.T. and heater circuit is shown in FIGURE and consists of a small converter transformer with 250V A.C. input, and 0-220V. A.C., 6.3V. A.C. output. The rectifier used was contact cooled (250V, 50 mA), and the smoothing circuit consisted of two 8 μ f condensers and a 1.5k resistor. The 30V. D.C. was supplied from an ex-government pack, mains operated from a constant voltage transformer, thus giving greater stability of the rate of rotation.

For high fields, such as encountered by the mill at the top of the mast, a slightly different arrangement is necessary in the grid circuit of the Cathode Follower, and this is shown in FIGURE 2 .

It was essential, in both mills, to have sign discrimination, and for this reason, reference signal generators were built into each mill. This reference voltage of fixed amplitude was fed into a Schuster circuit, incorporated in the amplifier, and hence the output obtained was either positive or negative depending upon the sign of the field, and was suitable to apply direct to a mirror galvanometer.

2.3 Recording.

Four Tinsley mirror galvanometers were used for recording purposes, two of long period for the collector signals and two of short period for the field mill signals. Spots of light were reflected from the mirrors onto the slit of a camera which carried 240 mm. sensitised paper. The camera had a mains operated motor, and by a suitable arrangement of gears a speed of approximately 36" an hour was obtained.

A synchronous motor (1 rev./min.) was used to drive a switching arrangement in a 50V. D.C. supply. This in turn operated a uniselector which cut off the supply to the fogging lamp at half minute intervals, for one second, thus giving half minute lines on the record.

3. Electrometers and Housing.

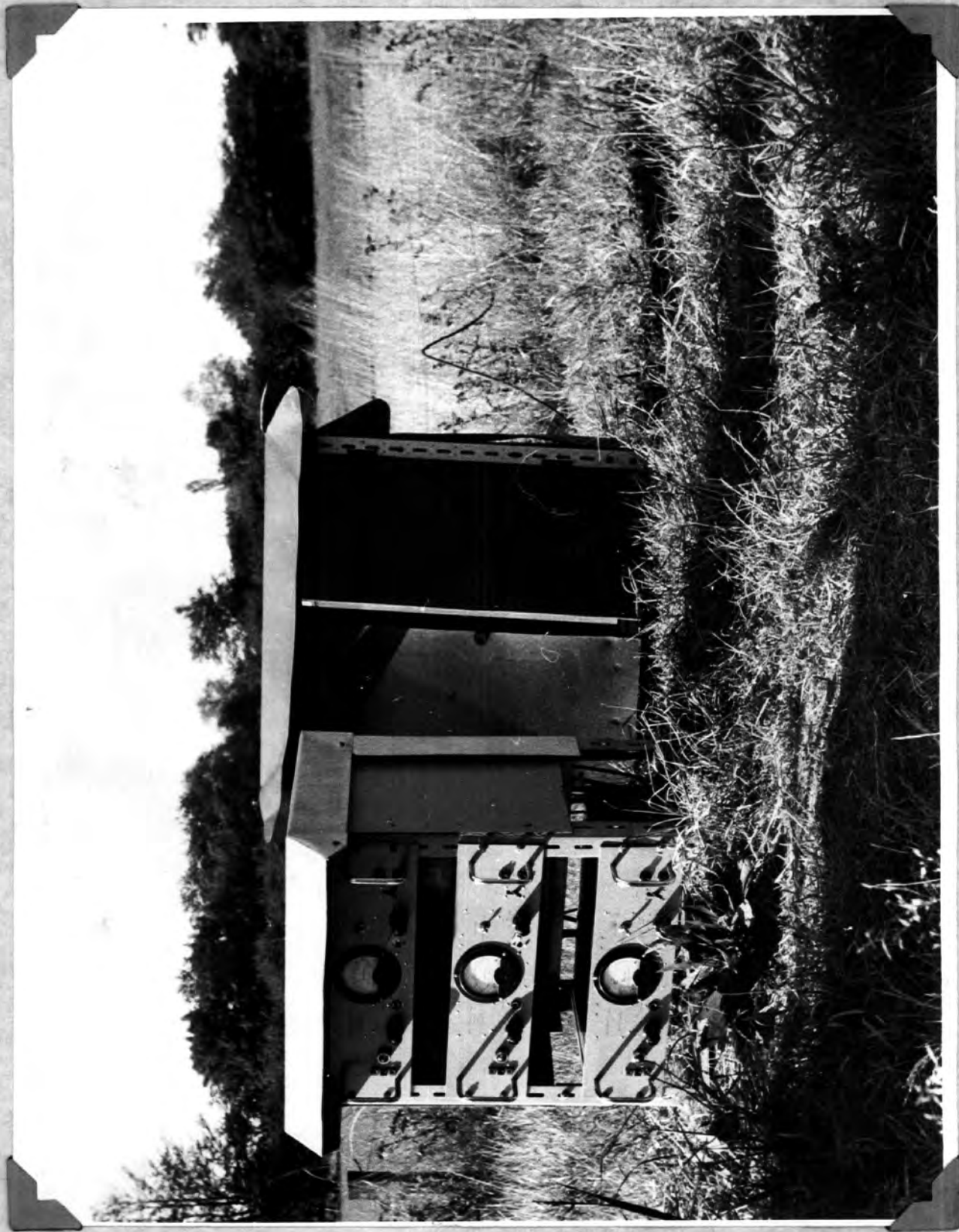

2.4 The Vibrating Reed Electrometers.

These electrometers consist of two completely separate circuits, the head unit and the indicator unit, which may be separated by distances of up to 200 feet when the heater voltages for the head unit drops below the required value. The head unit contains the first stage of amplification and a Cathode Follower, while the indicator unit supplies further amplification, rectification, and power supplies for both units. The signal is fed to one of three input resistors in the head unit, whose values are 10^8 , 10^{10} , 10^{12} ohms, respectively. The D.C. voltage developed across the resistor in use, is fed, through a hold off resistor, to the fixed plate of a dynamic capacitor. The varying voltage developed across this capacitor, proportional to the D.C. at the input resistor, is then fed to the grid of the first amplifying valve, then Cathode Follower and hence to the Indicator unit. In use it was found that the response time of the instrument was too short and to counteract this a 1,000 pf high insulation capacitor ($>10^{14}\Omega$), was connected across the input resistor in use.

2.5 Amplifiers.

The two oldest amplifiers in existence at the observatory proved to be very troublesome in operation and

4. Mill Amplifiers and Monitoring Panel.

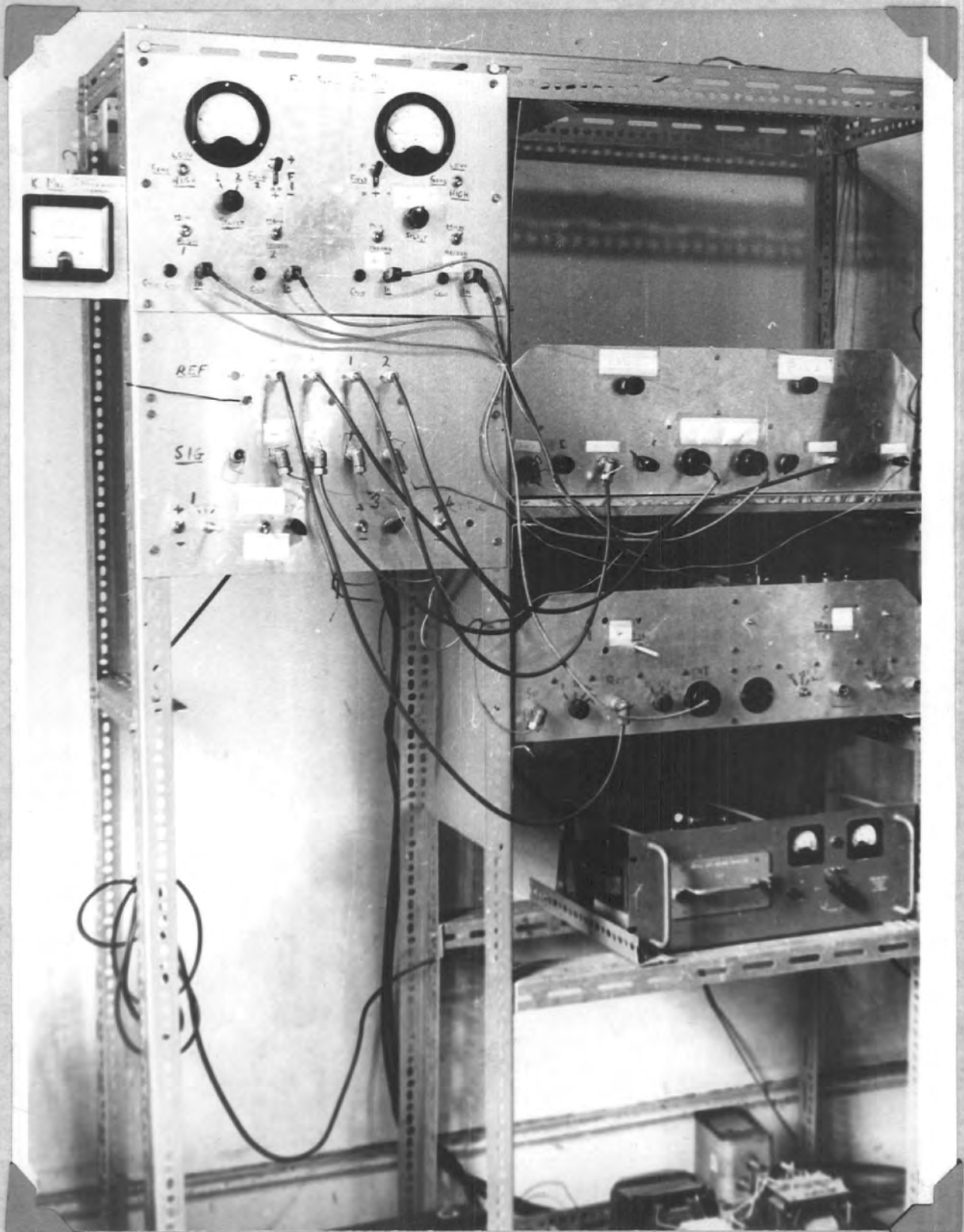

Mill Amplifier

FIG: 5.

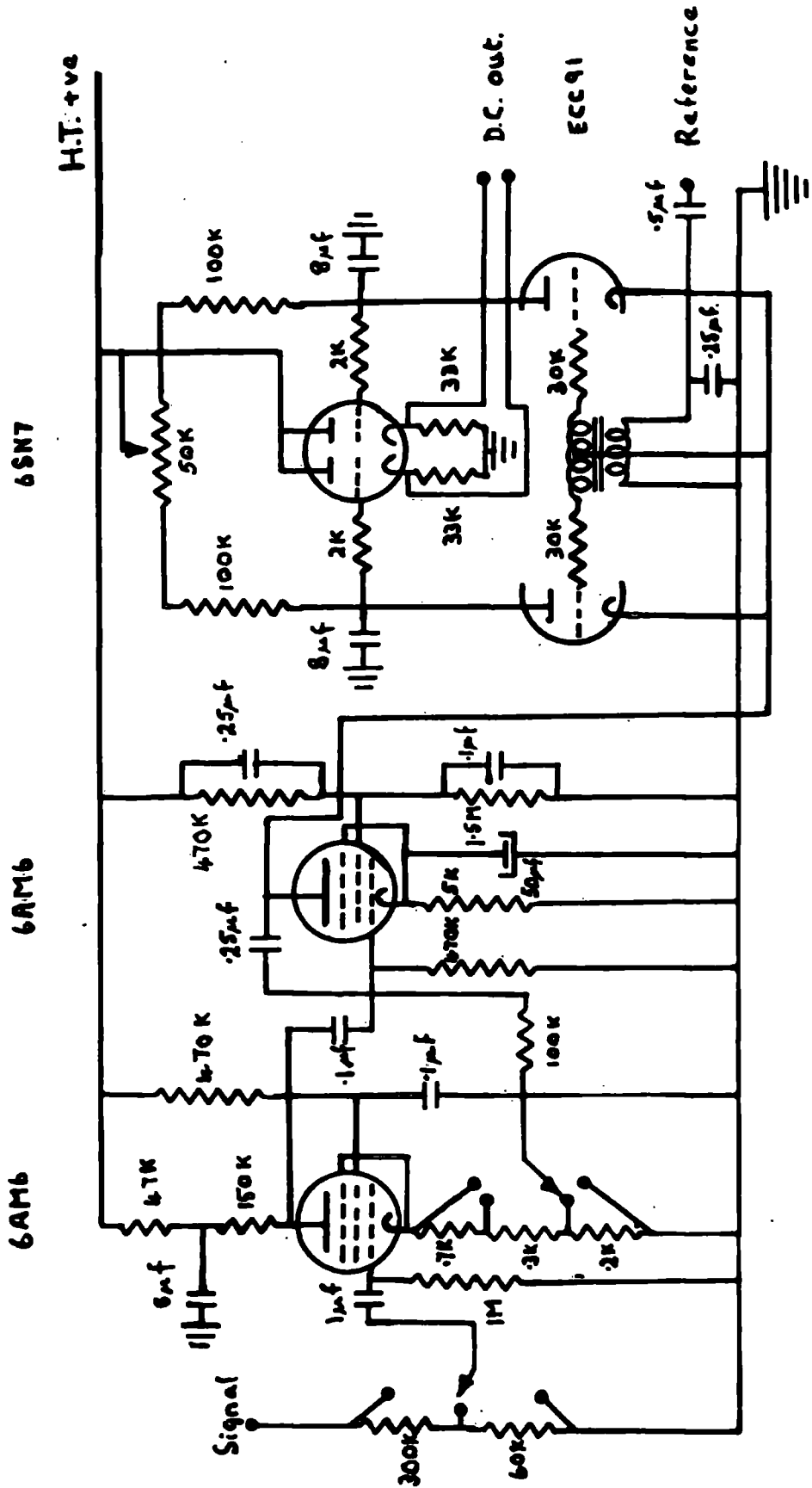

two more were built on the same lines as those built by the previous worker (Maund, 1958). There were two stages of amplification and the final stage was a Schuster circuit for sign discrimination purposes. Since the range of fields of interest lay between +500 volts/metre and -1,000 volts/metre, the amplifiers were operated at a fixed gain, and sufficient sensitivity could be obtained. They were housed in a room outside the recording room, and next to a monitoring panel, enabling all field changes to be observed visually without entering the recording room.

2.6 Other Apparatus.

The mast was a triple pole structure in five foot sections, each one braced with nylon covered steel wire. There were eighteen sections giving a total height of 90 feet, and the upper collector was rigidly fixed on top of the last section. The upper mill was fixed to one of the mast uprights approximately five feet below the collector. To prevent too much vibration, pieces of rubber were placed between the ring clamps on the mill, and the mast upright.

All signals were originally fed to a plugboard in a small hut at the foot of the mast, and hence to the

6. The Mast.



observatory. This hut also housed a "mains" plugboard and the 30V. D.C. power pack.

CHAPTER III

Calibration and Performance of Equipment.

3.1 Field Mills.

The field mill described in the previous chapter, was the obvious solution to the problem of prolonged continuous recording of field changes. Originally, a small Agrimeter was rebuilt from the remains of a previous worker's efforts, and was intended for use at the top of the mast. When put into operation, the difficulties encountered proved too numerous to warrant any further work along this line, and the Agrimeter was dispensed with in favour of the Field Mill. Fortunately, the department had considerable experience in their design and of their performance, and with the necessary modifications it was thought that one could be operated successfully at the top of the mast.

Two mills built by Maund (1958) were used by the present worker, the only alterations being the redesign and reconstruction of the Cathode Followers in the head units, and a new outer casing, easily removed for maintenance work.

Classical methods of Calibration, namely the simultaneous recording of signals from some form of potential equaliser, and the instrument to be calibrated, had been tried by previous workers and found to be impracticable.

7. The Field Mill and Calibration Pit.

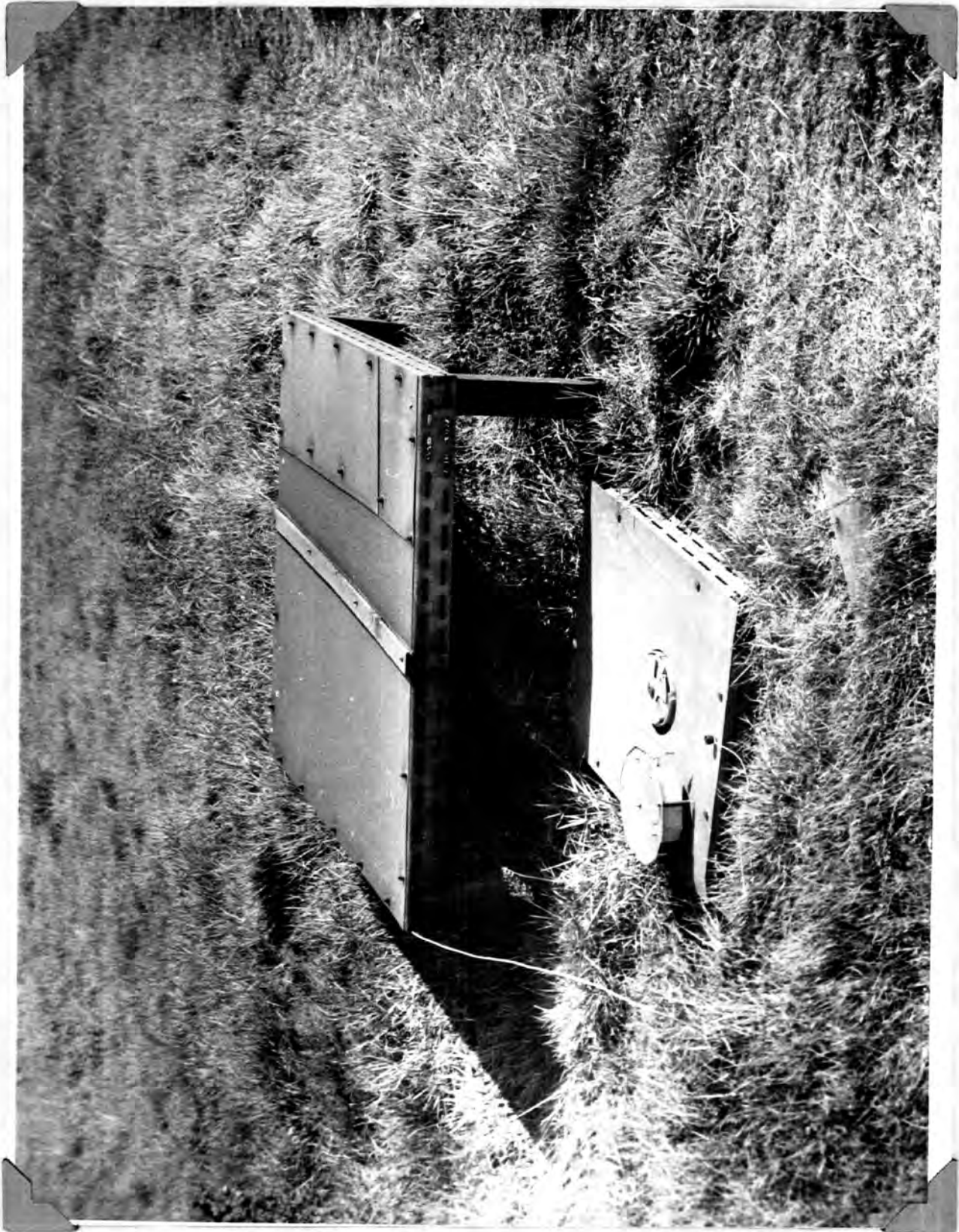

The method of calibration adopted in this case was as follows.

It was realised at the outset that some easily reproducible check would have to be available for use on the mills. This was achieved by fitting each of the outer casings with small lugs, capable of holding legs on a small insulated plate, which in position was parallel to and 3 cms. from the stator. Hence, by applying voltages to the plate, any required range of fields could be simulated, and spot checks of the head units and amplifiers carried out at any given time. These applied fields now had to be converted to absolute values of Potential Gradient, and the following method was adopted.

One of the field mills was let into a pit in the ground so that its vanes were just protruding through a hole in an earthed plate covering it, and in the plane of the earth's surface, FIGURE 7. A second, large, insulated plate was placed over the mill and 40 cms. from it, giving in effect a parallel plate condenser. The area of the upper insulated plate was such that edge effects could be neglected, and one could consider the field mill to be situated in a uniform field when voltages were applied between it and earth. A series of voltages were applied to the upper plate

Mill Calibration

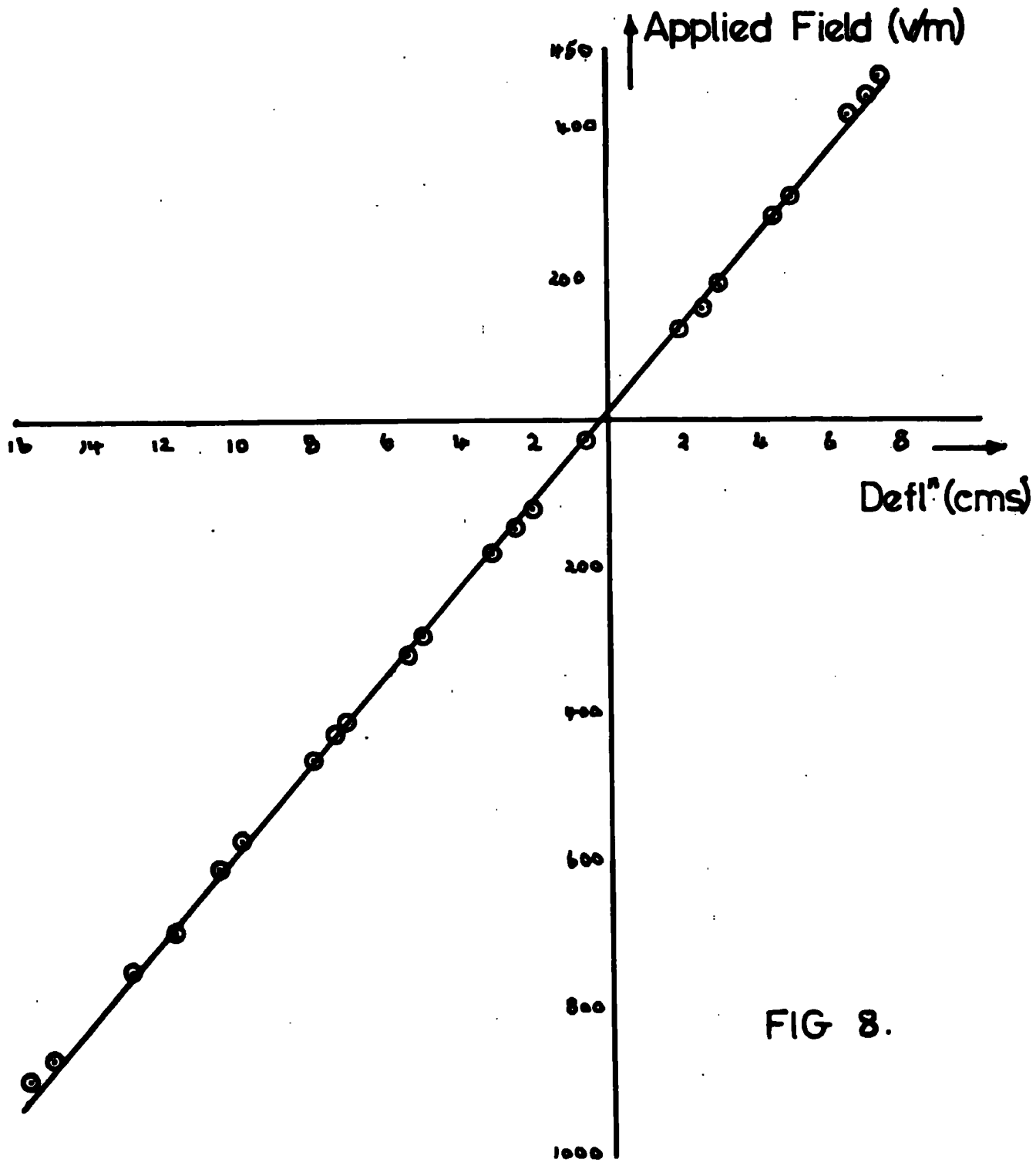

FIG 8.

in order to simulate fields between $-1,000$ V/m and $+500$ V/m., the range of interest in the present work. With the upper plate removed, this mill was run against the other, situated on the ground and a short distance from the pit. Simultaneous records were taken of the signals from both mills, and on analysing, a factor was obtained which enabled deflections from the second mill to be converted direct to absolute values of Potential Gradient.

From the calibration graph, FIGURE 8, it can be seen that the instrument is linear between $+500$ V/m and $-1,000$ V/m. The sensitivity was such that a field of 100 V/m gave a deflection of 1.2 cms., and since deflections of $.1$ cms could be read from the record, fields of the order 8 V/m could be measured quite readily. From an estimate of the accuracy with which the calibration was performed, fields could be measured to within ± 4 V/m. The apparatus was not in use long enough to investigate long term fluctuations in its behaviour, but short term variations could have been due to:-

- (a) a changing exposure factor dependent upon the condition of the surrounding ground;
- (b) characteristic variations in the head unit and amplifier.

The first of these could be eliminated, or at least its effect reduced, by keeping the grass well cut in the vicinity of the mill. Although the second of these defects could not be so easily disposed of, check calibrations with the small close fitting plate, before, during and after the taking of a record, enabled any necessary corrections to be made.

The mill functioned extremely well under conditions of light and moderate rain, but during heavy rain, bridging of the rotor stator gap by rain drops occurred and the insulation broke down. Since the present work is connected with nimbostratus conditions, only rarely did the rainfall exceed the maximum under which the mill operated satisfactorily.

3.2 Vibrating Reed Electrometers.

The calibration of the Vibrating Reed Electrometer was made reasonably easy by the inclusion in the meter, and hence recording circuit, of a standard type jack plug socket on the front panel. By inserting known D.C. voltages at the plug, the calibration of the instrument could be checked on any of the four ranges available, viz:- 0-30 mv., 0-100 mv., 0-300 mv., 0-1,000 mv. For known voltages, a potentiometer in the galvanometer circuit could be adjusted to give a

maximum galvanometer deflection, for full-scale deflections of the external meter. The calibration as a current measuring instrument was limited only by the accuracy with which the input resistor was known, and this was quoted in the makers' literature as $\pm 10\%$. This value was also checked experimentally, and found to be accurate. Hence the overall accuracy with which the rain current could be measured was limited by this fact, all other errors being considerably smaller than this. During calibration it was essential that the signal was free from all spurious effects, and for this reason, the head unit was shorted out, so that any signals originating at the collector might have no effect.

This method of calibration served only to standardise the recording circuit, and any check on the variability of the head unit had to be rectified by the makers. A simple check, however, was effected by using a water dropper. For known rates of drop fall, and drop charge, the meter reading could be noted, and the head unit rechecked at intervals.

The Vibrating Reed Electrometers functioned satisfactorily for both positive and negative inputs, the only modification necessary being the inclusion of a reversing switch in the meter circuit. In the case of negative inputs, the response

V.R.E. Calibration

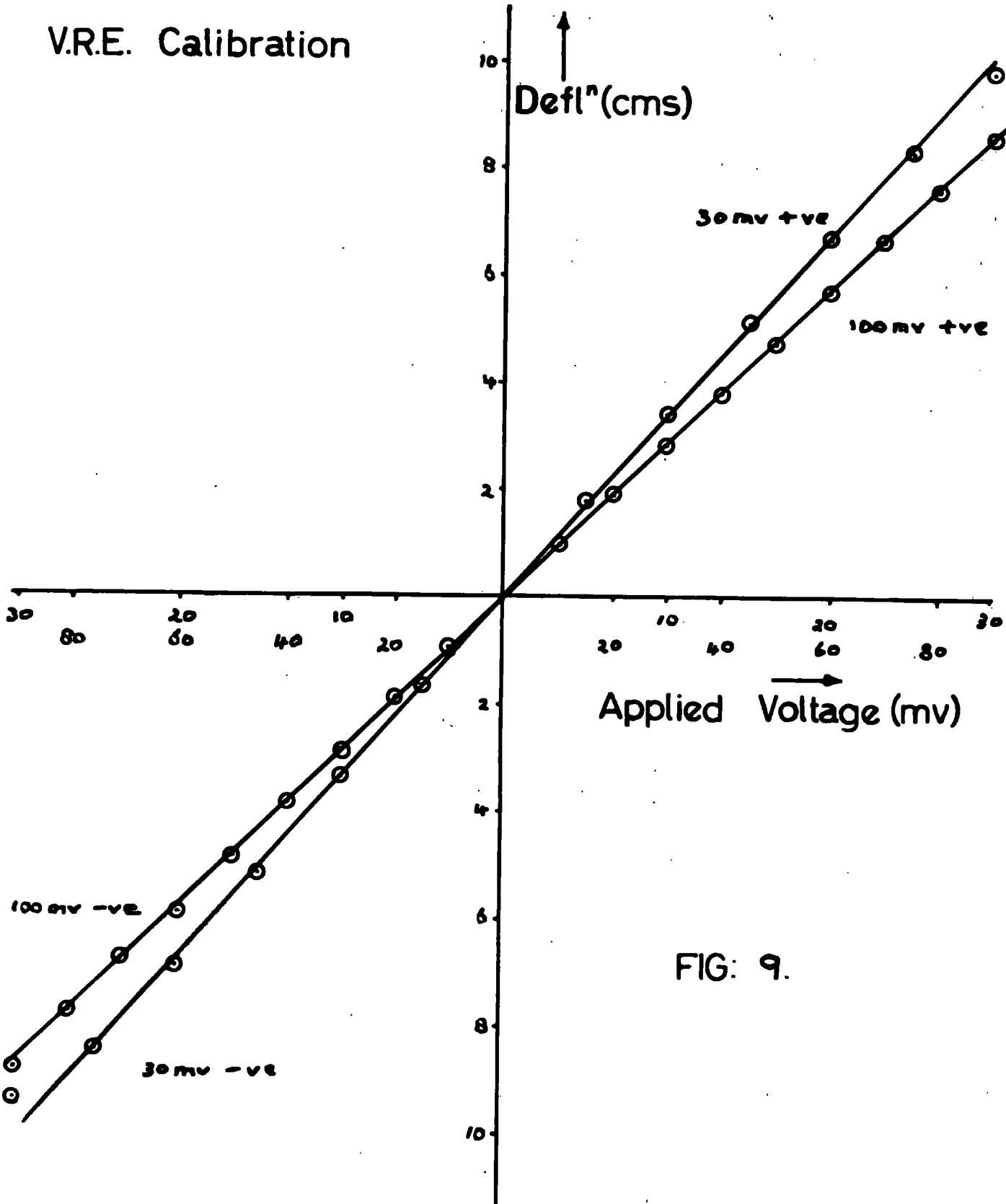

FIG: 9.

was linear up to about three-quarter scale on any one range; above this value the calibration curve tended to tail off. As the instrument was never used in this region, this defect had little effect on its general suitability for the purpose in hand.

One large defect was the considerable zero shift from day to day, and even during the taking of a record. The latter of these two faults could be accounted for by zeroing the instrument before and after a record, and taking an average zero over the period in question. It was found that, given long enough, the instrument settled back to within ± 2 mv of its original zero after the taking of a record, so that over a period of say 30 minutes, representing approximately 2 feet of record, the average zero will not greatly differ from an ideal zero since 2 mv corresponds to .5 cms. The day-to-day shift could be eliminated by adjusting a set zero control situated adjacent to the meter on the front panel. These fluctuations of the zero could be appreciated up to a point when it is realised that the instrument was permanently situated outside, and submitted to all the extremes of climate.

The instrument functioned well if a record was taken at the beginning of a storm of rain, but if it lasted over any

great length of time then invariably the insulation broke down. Similarly an early morning inspection after a night of rain showed a complete breakdown, and depending upon the atmospheric conditions, it required from approximately five hours to a day to dry out completely. To prevent moisture affecting the working of the dynamic capacitor, a small desiccator was incorporated in the head unit. This had to be removed and dried at intervals.

The smallest measurable deflection was 2 mm., and on the lowest range, i.e. 30 mv range, this corresponded to a current of $2.8\mu \mu\text{A}/\text{m}^2$, giving the sensitivity of the instrument. Both Vibrating Reed Electrometers were adjusted to give the same deflections for the same inputs, thus making comparison very much easier.

3.3 The Upper Mill.

Originally, it was proposed to run the upper mill, in position at the top of the mast, against one at ground level, already calibrated, in fine weather. It would then be possible to say that for known signals from the top mill, the field at ground level should be a certain value.

In disturbed weather, however, the space charge existing in the layers of air between the top and bottom of

the mast, would alter this relationship, and the difference between the expected and observed values would give a measure of this space charge.

Unfortunately, during the comparatively short time the upper mill was working, the fair weather fields experienced in Durham, were such as to make any calibration of this sort impossible. Ideal conditions would have been a dry day, with fields varying slowly between +300 V/m and -300 V/m. On the majority of days when such fine, dry weather was experienced, the field rarely rose above 50 V/m.

CHAPTER IV

Results and Discussion.

The results obtained with the apparatus described previously were limited to two half-hour periods; one on June 12th, the other on July 29th. Unfortunately, the reason for so few records was due, in the main, to circumstances beyond the present worker's control, namely the weather. Some facts and figures on rainfall as recorded at Durham Observatory are given later, for the six months ended 31st October, 1959. Suffice it to say that the monthly average was well below the normal value and the number of times that steady rain conditions occurred was limited, in the day time at least, to the two occasions mentioned above.

Obviously little, if anything, of lasting importance can come of so few recordings. Assuming, however, that the effects observed were correct, and this was checked as far as possible as regards reliability of apparatus, then a very interesting fact has been observed and may serve as a starting point for further research.

The rain currents at the top and bottom of the mast were measured on June 12th together with a measure of the Potential Gradient at the top, and the following observations made:-

1. Variations in the rain current values followed one another very closely, one being almost a copy of the other.
2. The current at the top, especially at the peaks, was many times greater than the corresponding current peak at the bottom, sometimes by as much as a factor of six.
3. Zeros and low values corresponded very well but since the upper collector was invariably on a lower sensitivity range, this could not be seen as clearly as peak values.
4. In all cases, peaks in the rain current trace corresponded to peaks in the Potential Gradient Trace. Some equally high Potential Gradient values, however, had comparatively low current values associated with them.
5. The rain currents remained positive and the Potential Gradient negative for almost the entire time of the recording, and even when positive values occurred, it was only for a matter of one or two minutes.

On July 29th, simultaneous records were taken of the Potential Gradients at the top and bottom, and the rain

current at the top. The following facts were observed:-

1. Once again the rain current at the top had exceptionally high values.
2. Each peak in the rain current trace coincided with a peak in the Potential Gradient Trace.
3. The sign of Potential Gradient and rain current followed one another all through the period of the recording. (*of opposite sign!*)
4. Large positive Potential Gradients were not accompanied by such large peaks in the negative value of the rain current.

These observations were surprising, especially with regard to the very high rain currents at the top of the mast. If we account for rain drop charging by some cloud process, the Potential Gradient changes observed were of the correct sign, to be the result of these high positive charges leaving behind correspondingly large negative charges in the cloud. These exceptionally high rain currents could be due to one of several spurious effects, and the possibilities are discussed in the remainder of the chapter.

To investigate the effects of splashing at the exposed edges of the collector, a piece of filter paper treated with a red dye solution, was placed in the funnel of the collector.

A stream of drops from the dropping apparatus, was allowed to fall on the outer edge of the collector shield, and on shattering, a number of the particles resulting, entered the funnel. Knowing the number of drops incident on the edge and the number of particles which enter the funnel, it is possible to obtain a measure of the contribution to the total current by these particles. By the same method a measure of the contribution to the total by drops shattering on the inner conical shield could also be obtained.

It was found that for every drop incident on the outer edge, eleven were incident directly on the funnel. Of the shattered particles an average of three per drop reached the collector. Hence the ratio of particles to directly incident drops is approximately 1:4. These particles would thus have to acquire a charge four times that carried by an average drop even to double the observed current. As the current was sometimes as much as ten times that at ground level they would have to acquire a much larger charge on splashing to account for the effect observed.

For drops incident on the edge of the inner conical shield, each one gave, on average, seventy-nine particles in the funnel. Using the respective areas exposed as a guide to the number of drops received, while seventy-nine

particles reached the funnel, thirty-three arrived directly. It is obvious that this greater number of particles could have a very marked effect on the observed value of the rain current. It must be remembered, however, that the concentration of lines of force at the inner conical shield would be much less due to the shielding effect of the higher outer casing. In addition, the drops from the dropping apparatus are very much larger than the normal rain drop. This would mean then that the ratios quoted previously are, if anything, in favour of the particles, and only if the Potential Gradient at the top of the mast reached high values, would these splashed drops play an important part in the production of the high rain current observed. Unfortunately, there was no way of knowing the absolute value of the Potential Gradient in this region. In any case, the arrival of these very highly charged drops would have been intermittent, and should have shown up as isolated peaks in the record. This was not the case, and all increases and decreases were smooth curves, following the Potential Gradient changes.

If the drops arriving at the bottom collector had fallen through a region of intense negative space charge, then by collection, their charges would have been considerably decreased. If, however, this space charge had existed,

the effect being investigated, namely the reversal of sign of Potential Gradient between top and bottom would have been evident, but this was not the case.

In a report published recently, Vonnegut, Moore and Enslie have suggested as a consequence of a series of investigations they have carried out in thunderstorms, that precipitation is a direct result of electrification in some way. Perhaps the effects observed could be explained in this manner, and that the precipitation only acquires its charge in the lower levels of the atmosphere beneath the cloud.

If this is not the case, then it must be assumed that it is a very localised effect due in some measure to collection of charge by wash out of Point Discharge ions. This, however, cannot explain in full the great difference in value of the precipitation currents as measured at the top and bottom of the mast. A much fuller investigation of the facts observed so far, is necessary to enable a complete treatment of the problem to be attempted.

Suggestions for further work.

First and most essential, a more comprehensive study of the precipitation and Potential Gradient variations should be attempted, with the apparatus in its present positions, and

also at various levels on the mast. For this to be possible, some method would have to be devised for ensuring the satisfactory working of both mills, and collectors, in all repeat all weather conditions. This resolves itself into two problems, namely the elimination of insulation break down in heavy rain, and the weatherproofing and calibrating of the upper mill.

It is possible that the observed facts can be explained by splashing of the rain drops at the edges of the collector, and this should be investigated more fully than has already been attempted, simulating conditions at the top of the mast, as far as is experimentally possible.

The mast and associated apparatus may act as a Point Discharge element, although this is unlikely in conditions of steady rain (Nimbo Stratus conditions). Future work should not, however, rule out this possibility.

Correlation of precipitation currents in a horizontal direction, already being attempted, might also yield useful information in this connection.

If, as the present worker thinks, the observations made are reliable, then the above are just a few of the more obvious approaches to what could possibly be a very wide, comparatively new, line of research.

APPENDIX

Summary of Rainfall as recorded at Durham
Observatory for the months
April-September, 1959.

<u>Month</u>	<u>Total</u>	<u>Average</u>	<u>Number of rain days</u>
April	1.50 ins.	1.81 ins.	13
May	0.52 ins.	2.13 ins.	7
June	2.41 ins.	1.97 ins.	13
July	1.22 ins.	2.59 ins.	8
August	0.25 ins.	2.71 ins.	4
September	0.70 ins.	1.99 ins.	5

The total for the six months ended 30th September, 1959, was 6.6 inches.

The average for this six months over a period of years is 13.2 inches.

Acknowledgments

The writer wishes to acknowledge with thanks the invaluable help and encouragement he received from Dr. J.A. Chalmers, who supervised the work.

He is also indebted to Professor G.D. Rochester, the Geophysics Research Centre, Air Research and Development Command, United States Air Force [under Contract No: AF.61(514)-1072], who provided a grant for maintainance and apparatus, and, last but not least, to his fellow research students.

References

- Adamson, J. 1958. The Compensation of the Effects of Potential Gradient Variations in the Measurement of the Atmospheric Air Earth Current. Ph.D. Thesis.
- Adkin, C.J. 1959. Measurements of the Atmospheric Potential Gradient on a Canadian Glacier. Q.J.R. Met. Soc. 85. No.363.
- Baldit, A. 1911. Sur les charges électriques de la pluie au Puy-en-Velay. C.R. Acad. Sci. Paris. 152 pp.807-809, 154 pp.731-733.
- Beccaria, G.B. 1775. Del' elettricità terrestre atmosferica a cielo sereno (Turin).
- Benndorf, H. 1910. Luftelektrische Beobachtungen an Graz. S.B. Akad. Wiss. Wien. 119 pp.89-110.
- Chauveau, B. 1900. Études de la variation de l'électricité atmosphérique. Annales du B.C.M. 5 p.1.
- Elster, J. and Geitel, H. 1888. Über eine Methode, die elektrische Natur der atmosphärischen Niederschläge zu bestimmen. Met. Z. 5 pp.95-100.
- Franklin, B. 1752. Phil. Trans. 47, p.289.
- Gunn, R. 1950. Free electrical charge on precipitation inside an active thunderstorm. J. Geophys. Res. 55 pp.171-178.
- Herath, F. 1914. Die Messung der Niederschlagselektrizität durch das Galvanometer. Phys. Z. 15 pp.155-159.
- Kähler, K. 1908. Registrierung der Niederschlagselektrizität mit dem Benndorf-Elektrometer. Phys. Z. 9 pp.258-260.
- Kelvin Lord. 1860. Electricity, atmospheric. Nichol's Cyclopaedia, 2nd Edition. Papers on Electrostatics and Magnetism, pp.192-208.

- Kelvin Lord. 1860. Atmospheric electricity. Roy. Instn. Lecture. Papers on Electrostatics and Magnetism, pp.208-226.
- Kelvin Lord. 1860. Notes on Atmospheric Electricity. Phil. Mag. and B.A. Papers on Electrostatics and Magnetism, pp.316-320.
- Lemmonier, L.G. 1752. Observations sur l'electricite de l'air. Mem. Acad. Sci. 2 p.233.
- Linss, F. 1887. Über emige die Wolken - und Luft- elektrizität betreffende Probleme. Met. Z. 60 pp.340-351.
- De Saussure, H.B. 1779. Voyages dans les Alpes (Geneva).
- Scrase, F.J. 1933. The Air Earth Current at Kew Observatory. Geophys. Mem. Lond., 58.
- Scrase, F.J. 1938. Electricity on Rain. Geophys. Mem. Lond., 25 pp.1-20.
- Simpson, G.C. 1909. On the electricity of rain and its origin in thunderstorms. Phil. Trans. A. 209, pp.379-413.
- Simpson, G.C. 1949. Atmospheric electricity during disturbed weather. Geophys. Mem. Lond. 84, pp.1-51.
- Volta, A. 1800. Lettres sur la météorologie électrique.
- Wall, W. 1708. Phil. Trans. 26, p.79.
- Weiss, E. 1906. Beobachtungen über Niederschlag- selektrizität. S.B. Akad. Wiss. Wien. 115. pp.1285-1320.
- Wilson, C.T.R. 1916. On some determinations of sign and magnitude of electric discharges in lightning flashes. Proc. Roy. Soc. A. 92. pp.555-574.
- Winkler, J.H. 1746. Die Stärke der elektrischen kraft des Wassers. (Leipzig: Breitkopf.)



**UNIVERSITY LIBRARY
DURHAM**

CLASS No.	THESIS
AUTHOR	
ACCESSION No.	STORE