



Durham E-Theses

A study of high strength concrete

Kemp, J. R.

How to cite:

Kemp, J. R. (1970) *A study of high strength concrete*, Durham theses, Durham University. Available at Durham E-Theses Online: <http://etheses.dur.ac.uk/10301/>

Use policy

The full-text may be used and/or reproduced, and given to third parties in any format or medium, without prior permission or charge, for personal research or study, educational, or not-for-profit purposes provided that:

- a full bibliographic reference is made to the original source
- a [link](#) is made to the metadata record in Durham E-Theses
- the full-text is not changed in any way

The full-text must not be sold in any format or medium without the formal permission of the copyright holders.

Please consult the [full Durham E-Theses policy](#) for further details.

"A STUDY OF HIGH STRENGTH CONCRETE"

BY

J.R.KEMP.

Thesis submitted for the Degree of
Master of Science in the University
of Durham.

Engineering Science Department.

March 1970.



ACKNOWLEDGEMENT

It is with great appreciation that I acknowledge the help and advice generously given at all times by Professor G.R.Higginson, Mr.G.M.Parton and many of the technical staff; also to Messrs. Lionweld Ltd. without whose financial assistance this thesis could not have been completed.

ABSTRACT.

The thesis describes the initiation of a research programme which is in two parts:-

- (I) An investigation of possible methods of producing high strength concrete.
- (II) A study of the creep characteristics of these concretes.

For convenience and clarity, therefore, the thesis is presented in two parts, each being suitably entitled so as to represent the present state of the investigations into the above two topics.

The actual work embodied in each part of the thesis can be summarised as follows.

PART I: "A preliminary investigation of the effect of hydrostatic pressure, applied during setting, on the strength of concrete."

A preliminary investigation into one possible method was carried out, the method being that of manufacturing concrete specimens under an applied pressure, the specimens also being subject to suction and vibration.

Two test series were carried out, one to investigate the effect of intensity of pressure, the other to investigate the effect of time of application of the pressure. The

apparatus for processing the concrete is fully described, and details and results of the above tests are given.

The main conclusion drawn, is that the process is undoubtedly beneficial to the strength of concrete, both the intensity, and time of application of the pressure effecting the possible strength increase which can be obtained.

The test specimens were cylindrical in shape, the size being restricted to that of 2" diameter by 2" long in order that reasonably high pressures could be obtained.

PART II: "The design and development of a creep machine".

The design and development of a creep machine capable of testing a maximum of six small cylindrical specimens simultaneously is fully described. The specimens are located in the creep machine in tandem and are loaded by means of a system of lever arms, the maximum design load being 10 tonf, the diameter of the specimens being 2".

Due to the limited time available, development of the machine was not completed, and hence no preliminary creep tests were carried out.

CONTENTS

	Page
Title	1
Acknowledgement	2
Abstract	3
Contents	5
 <u>CHAPTER 1. INTRODUCTION</u>	 7
1.1. Development of Concrete Technology	8
1.2. Demand for High Strength Concrete	12
1.3. Aims of the Investigations	13
 <u>PART I. A PRELIMINARY INVESTIGATION OF THE EFFECT OF HYDROSTATIC PRESSURE, APPLIED DURING SETTING, ON THE STRENGTH OF CONCRETE.</u>	
 <u>CHAPTER 2. LITERATURE SURVEY</u>	 15
2.1. Factors Affecting Concrete Strength	16
2.2. Theory of Failure	29
 <u>CHAPTER 3. INVESTIGATIONS CARRIED OUT</u>	 33
3.1. Introduction	34
3.2. Theoretical Reasoning Behind Adoption of Process being Investigated	
3.3. Apparatus	36
3.4. Method	44
3.5. Selection and Grading of Aggregate	55
3.6. Test Series	68
3.7. Details of Mixes	71
3.8. Testing of Specimens	73

(cont'd)

CONTENTS (cont'd)

	Page
<u>CHAPTER 4. RESULTS</u>	75
4.1. Tabulated Results	76
4.2. Discussion of Results	83
4.3. Conclusions	88
<u>PART II. DESIGN AND DEVELOPMENT OF CREEP MACHINE</u>	
<u>CHAPTER 5. CREEP OF CONCRETE</u>	89
5.1. Concrete Creep	90
5.2. Need for Research	90
<u>CHAPTER 6. LITERATURE SURVEY</u>	91
6.1. Physical Factors Affecting Concrete Creep	92
6.2. Theory of Concrete Creep	96
<u>CHAPTER 7. INVESTIGATIONS CARRIED OUT</u>	99
7.1. Design Approach	100
7.2. Design of Creep Machine Frame	100
7.3. Design of apparatus for Alignment of Specimens	110
7.4. Design of Creep Measuring Device	113
<u>REFERENCES</u>	114

CHAPTER 1. INTRODUCTION

1.1. DEVELOPMENT OF CONCRETE TECHNOLOGY.

The processes of batching and mixing are the fundamental principles of concrete making and are the same today as they were in Roman times; it is the knowledge behind these processes and the quality of the product which have been improved to such an extent that over the past fifty years the crushing strengths of concrete have been more than trebled.

The major part of this development has without doubt taken place since the turn of the century, when due to the introduction of the technique of re-inforcing concrete, the full potential of concrete as a structural material was realised.

Although this growth of knowledge of the principles of concrete is chiefly responsible for its developments of strength the development of the quality of one of its constituents, cement, cannot be discarded, since its strength has also been greatly improved upon since the first British Standard for cement was issued in 1904. At that time cement was manufactured by over sixty companies using various production techniques which created a situation where cement was a very variable product due to variations in burning and

fineness, and hence a variation in its setting time and strength were experienced. Before 1907, when Rapid Hardening cement was introduced, only what we now call Ordinary Portland cement was produced, whereas today there are some ten main types, as well as a number of modified varieties; the development of which has contributed much to the development of concrete strength.

On the other hand, aggregates have changed very little, the materials used are much the same today as they were at the start of the century and the sizes employed in concrete are generally identical. The methods of manufacture have of course been advanced considerably, but it is the knowledge behind the effect of the aggregate on mix design that most progress has been made. At the turn of the century very little was known by the practicing engineer about the effects of the mix design proportions of the aggregate, or the effects of the aggregate grading, and therefore, "all-in" aggregates were the most commonly used, although research workers were beginning to realize the importance of the aggregate grading and also the advantages to be gained from using single sized coarse aggregates, i.e. gap graded aggregate.

The greatest advancement on the effects of aggregates on concrete occurred during the period between the wars and was responsible for B.S.882 which was first published in 1940. This advancement coincided with and partly resulted from the progress which had been made in the field of mix-design during the same period.

In the early years of the present century, mix-design as we know it today was almost non-existent and different views were held on what was then called the proportioning of the mixes, but it was generally realized that unless concrete was sufficiently workable to be adequately compacted it would be of poor quality. During the latter years of the nineteenth century, Feret had shown that a relationship existed between concrete strength and its density, and although this relationship included a factor which was determined by the amount of water in the mix, it does not seem as though the part played by the water in determining the strength of the mix was fully understood.

In 1909, Zielinsky approached what is the present conception of mix-design by demonstrating that a relationship existed between the strength and the water/cement ratio of the mix. Zielinsky's work, however, received little notice and it

was not until 1918 that Abrams published results of tests on a wide range of mixes and produced his now well known water/cement ratio law. Abrams continued his investigations on the basis of the water/cement ratio law and produced many more written papers which aroused a growing interest amongst other investigators, who extended Abrams work by investigating the effects of aggregate grading and workability. Glenville added precision to Abrams work by establishing a relationship between strength and compaction and thus revealed that it was not necessary for a mix to be workable but only that it should be fully compacted. Many other investigations into the effect of aggregate grading, size, texture, and mix proportions on the workability of the mix were carried out, the cumulative result of which was that mix-design tables were drawn up on the basis that the strength of concrete was solely dependent upon the water/cement ratio, and the workability of the mix upon the aggregate type, size and grading, and the mix proportions.

With a greater degree of quality control and sample testing these general principles, in some cases no longer suffice, and the aggregate properties and its grading have to be taken into account, especially when high strength concrete is required.

1.2. DEMAND FOR HIGH STRENGTH CONCRETE:

The demand for high strength concrete arose mainly from the introduction and subsequent development of the technique of prestressing concrete. The technique was introduced in 1930 by Freyssinet, but it was not until after the war, when there was a shortage of steel, that the technique was employed to any great extent in the construction industry. Employment of the technique increased simultaneously with its development, and today the demand for concretes of high strengths is very common. However the continued development of the prestressing technique demands concretes of even higher strengths.

The demand has been accentuated by a growing interest by engineers in the economies of structural design that may be achieved in some members by the use of high strength concrete. At the present time, concrete with a maximum strength of say 10,000 lbf/sq.ins. can be used to advantage for the lower parts of columns in very tall buildings, and it is envisaged that there would be an economical use for concrete of even higher strengths if it could be produced in new ways which did not involve much greater cost than is traditional. It seems likely that if any new method of high strength concrete production is evolved, it would be too

expensive and difficult for insitu concrete production but could possibly be accommodated in the production of pre-cast units, the employment of which has rapidly increased in recent years.

1.3. AIMS OF THE INVESTIGATIONS:

Although the strength increase of concrete is economically advantageous, the use of high strength concrete must be approached with caution, because the material is likely to become more brittle as the strength is increased and there is a need for more information on the modulus of elasticity, drying shrinkage and creep of this type of concrete to enable designers to check that cracking will not occur as a result of excessive movements or deflections of the structure. The creep and shrinkage characteristics are most important, since in time they can produce, in a member which is under sustained loading, deformations which can be two or three times as great as the elastic deformation.

A long term research programme has thus been set up to investigate the problem concerned, namely,

(i) To investigate possible methods by which high strength concrete can be produced.

(ii) To investigate the characteristics of these concretes, with special emphasis on their creep characteristics.

The aim of the work described in this thesis is to initiate this research programme by means of preliminary investigations into the aforementioned topics, and thus form a basis from which further work can be evolved.

PART I. A PRELIMINARY INVESTIGATION OF THE
EFFECT OF HYDROSTATIC PRESSURE,
APPLIED DURING SETTING, ON THE STRENGTH
OF CONCRETE.

CHAPTER 2. LITERATURE SURVEY

2.1. FACTORS AFFECTING CONCRETE STRENGTH.

The great advancement which has taken place in concrete technology can be mainly attributed to the many investigations which have been carried out. These investigations originate from, and probably resulted from, a publication in 1918 by D. Abrams in which he presented the first analytical and methodical approach to mix-design by pronouncing his now well known water/cement ratio law, which stated that the strength of concrete should be considered as only related to the ratio of the amount of cement to the amount of water in the mix. The ensuing investigations which followed this statement revealed that many other factors besides the water/cement ratio influence concrete strength, and with the ever-increasing demand for concrete of higher strengths, these factors must be taken into consideration.

Some of the factors concerned are listed below and are followed by a brief review of some of the literature which has made their importance realised.

Some factors which affect concrete strength:-

- (1) Water/Cement Ratio.
- (11) Characteristics of the Aggregate.
- (111) Cement paste - Aggregate Bond Strength.

- (IV) Shape and size of Test Specimen.
- (V) Characteristics of Testing Machine.
- (1) Water/Cement Ratio.

The importance of the proportion of water to cement in governing the strength of a concrete mix has been recognised for many years. The classical work on the subject was done by D. Abrams (1918) and he is generally credited with establishing the so called "water/cement ratio law" which states that

"With given concrete materials and conditions of test the quantity of mixing water used determines the strength of the concrete, so long as the mix is of a workable plasticity"

Later work has shown that the above statement is incorrect in that the concrete need not be workable but only that it is fully compacted. The ease with which full compaction can be obtained depends on the workability of the concrete and other things being equal this increases as the water in the mix is increased. On the other hand, an increase in water/cement ratio results in a decrease in strength. Therefore, if an initially workable concrete of fixed proportions were made with steadily decreasing water/cement ratios and the strength plotted, a typical water/cement ratio-strength curve would be obtained up to the point where the mix became too

dry to be completely compacted, when the strength would rapidly fall off. If, when the point of maximum strength had been reached, a more efficient method of compaction had been employed, vibration, then the water/cement ratio could have been further reduced without causing incomplete compaction and the point at which the strength curve would have fallen off would have been raised further up the water/cement ratio - strength curve. These effects are shown in Fig. 2.1.

(11) Characteristics of the Aggregate.

The significance of the aggregate in a concrete mix has changed enormously, from being more or less considered as a cheap inert filler 50 years ago, to its present day status of being that of an important ingredient specially selected for the concrete required. This change has been due to the realisation of the effects the aggregate has on the ultimate strength of concrete, these effects originating from two properties of the aggregate, namely,

- (a) its nature, i.e. size, texture, and
- (b) its grading.

(a) Nature of Aggregate

(i) Size of Aggregate:-

Results of tests carried out by S. Walker, D.L. Bloom and

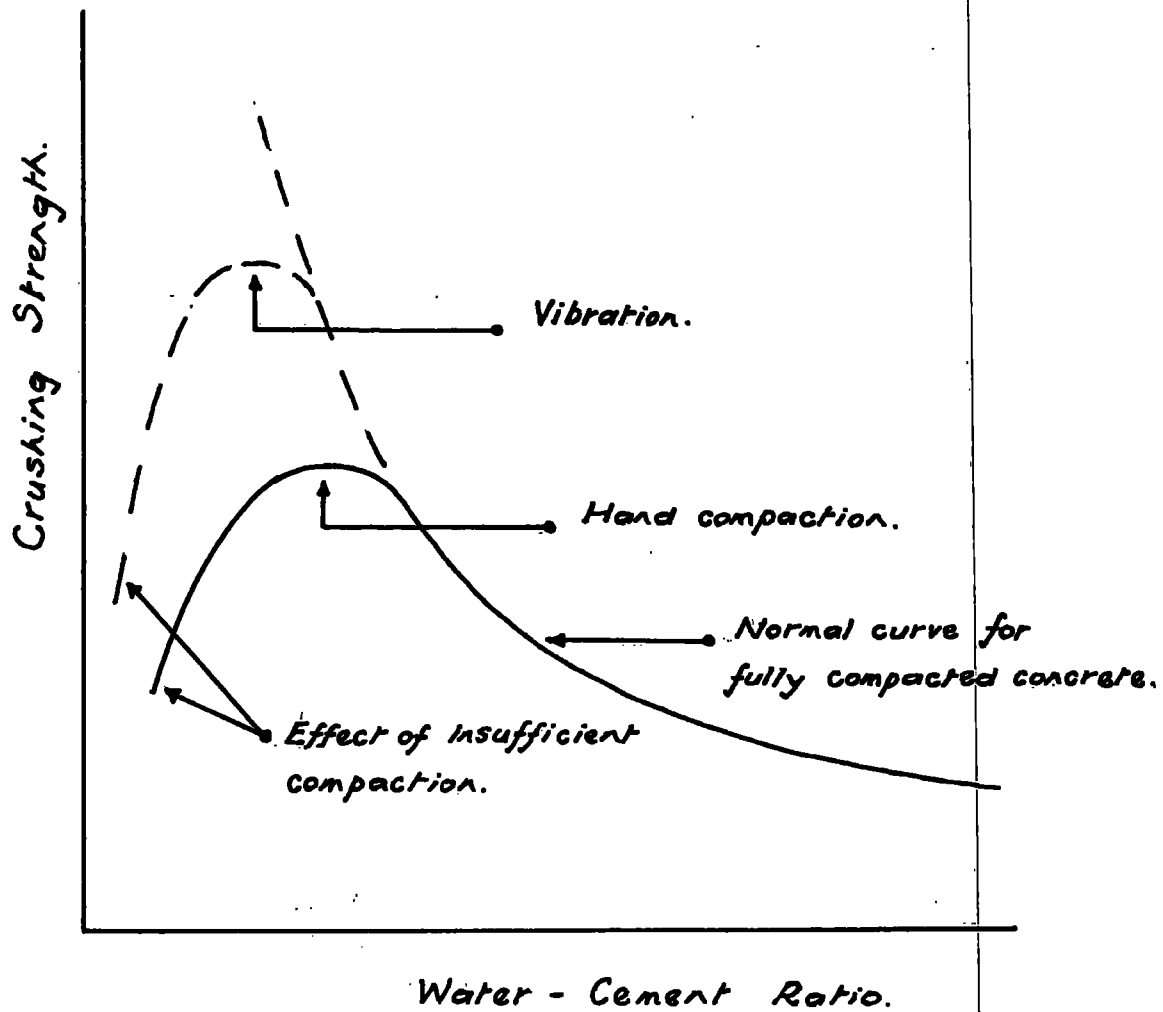

Fig. 2.1 - Effect of varying the W/C
ratio in a mix of constant
proportions.

R.D. Gaynor (1959) on sizes of aggregate ranging from $\frac{1}{8}$ ins. to $2\frac{1}{2}$ ins. indicated that as the coarse aggregate size is increased, mixing water requirements is reduced, lowering the water/cement ratio and tending to improve strength. Apparently at the same time, inclusion of large aggregate particles is in itself detrimental to strength, probably because of reduced surface area for bond and reduced total-cross-section of particles to resist shear. For increases in size up to about $\frac{3}{4}$ ins. the effect of reduced water predominates and strength increases. Beyond this point the advantage of reduced water is more than offset by the large pieces of aggregate which in themselves cause strength reduction.

After extending the above work, S. Walker and D.L. Bloem (1960) concluded that the size of coarse aggregate exerts an influence on concrete strength independently of the water/cement ratio, strength becomes less as maximum size of course aggregate is increased.

Further work by D.L. Bloem and R.D. Gaynor (1963) substantiated the above conclusions and also indicated that generally in the leaner concretes of lower strength level, the reduction in mixing water will be more than sufficient to offset the detrimental effect of size, with the result that the larger sizes will yield higher strengths. In rich, high-strength

concretes, the effect of size will dominate and the smaller sizes will produce higher strengths.

(11) Shape and Texture of Aggregate:-

The shape and texture of the aggregate are two properties which influence the amount of mixing water required to produce a workable mix, and thus have an effect on the ultimate strength of the concrete.

Aggregate particles which have sharp edges and a rough surface, such as crushed stone, need more water than smooth and rounded particles to produce concrete of the same workability. It may be necessary to increase the cement content of a mix made with crushed aggregate or irregularly shaped gravels to allow water to be added to make the concrete sufficiently workable without reducing the strength below the required level. However, a crushed aggregate concrete may have a higher strength than a smooth or rounded aggregate concrete of the same water/cement ratio, (i.e. greater bond strength), and this extra strength may be sufficient to offset the effect of the extra water.

(b) Grading of Aggregates.

The grading of the aggregate affects the workability of the mix and as the workability determines the ease with which concrete can be compacted it follows that the mix proportions of the aggregate will therefore determine the minimum

water/cement ratio for complete compaction and thus have an important though indirect effect on the strength.

(111) Cement paste - Aggregate Bond Strength.

After carrying out extensive tests, conclusions drawn by K.M. Alexander (1959) are as follows:-

- (i) At 7 days, large differences can exist between the strength of the bond formed between the same Portland cement and different strong, uniform aggregates.
 - (ii) No evidence was found of significant differences of bond strength between different samples of the same rock type.
 - (iii) Reactivity of aggregate is not necessarily associated with an increased rate of bond strength development.
 - (iv) The strength of the cement-aggregate bond decreases with increasing water content at a rate which corresponds to an approximately linear relationship between the proportion of cement in the paste, and the logarithm of the bond strength.
 - (v) In general, the 28 day strength of the cement-aggregate bond was found to be 50 per cent greater than the 7 day value.
 - (vi) All cement-aggregate bond strengths observed were lower than the strength of the adjacent portland cement paste.
- However, since the two quantities are not separated by too large a margin, the presence of even slightly angular projections or depressions on the surface of an otherwise smooth aggregate pebble could cause the mechanism of tensile

failure to change from preferential rupture of the bond to preferential rupture through the paste in the region of the surface irregularity.

(vii) The evidence available so far suggests, that under comparable conditions there is a characteristic bond strength for each rock type.

(viii) Cement-aggregate bond strength decreased rapidly with increasing size of aggregate, the strength of the bond to 3 inch aggregate, for example, being only about one-tenth of the corresponding value for $\frac{1}{2}$ inch aggregate. However, for a number of reasons it is thought that the effect in concrete will not be nearly as marked as that shown by isolated cement-aggregate interfaces such as those studied here.

The above conclusions were drawn from tests in which the cement-aggregate bond strengths were determined either by measuring the transverse load required to reapture the bond between sawn aggregate cubes, clamped as shown in Fig. 2.2a, and projecting beams of paste, or by centre point loading of composite prisms such as that illustrated by Fig 2.2b, which were designed for preferential failure along the interface I located at the mid point of the span.

(IV) Shape and Size of Test Specimen.

It is well known that the compressive strength of concrete of a given mix is not the same when obtained on different size

Methods used for determining cement-aggregate bond strength.

Fig. 2.2a.

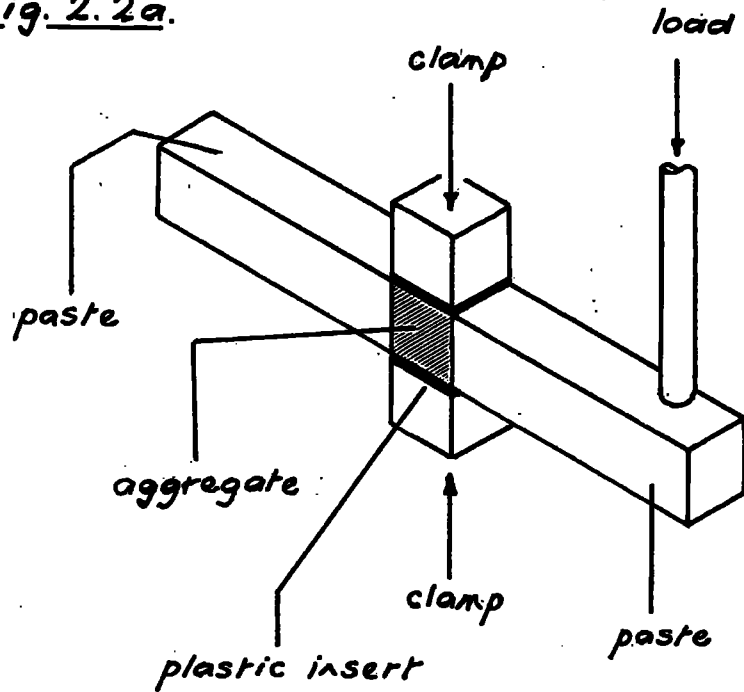
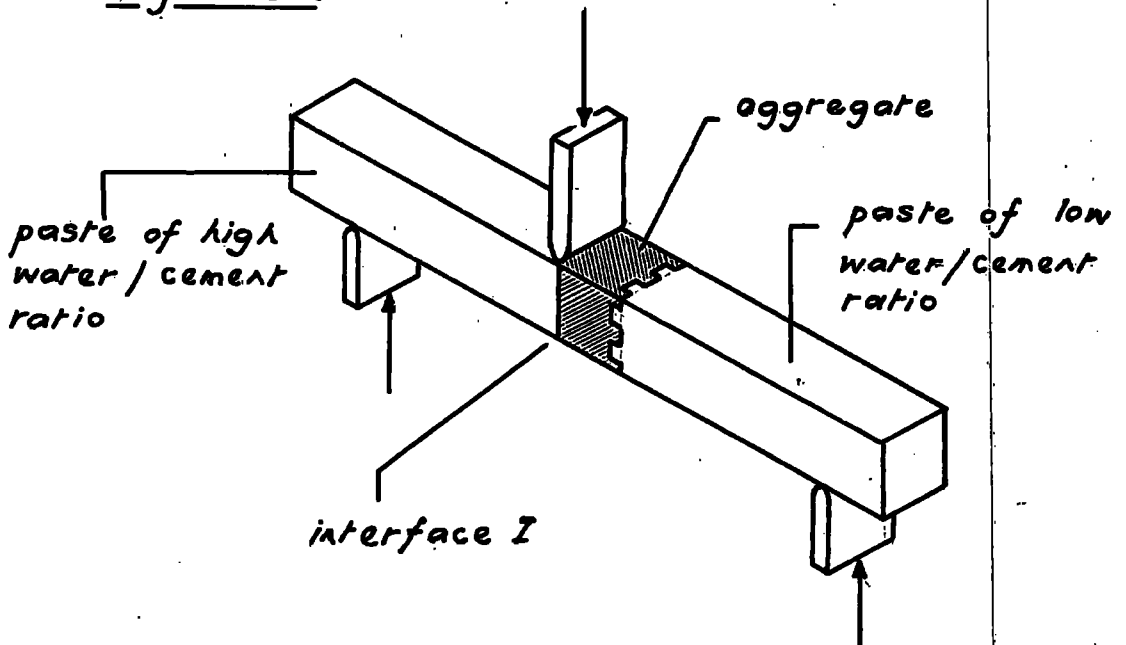

Fig. 2.2 b.



and shape test specimens . . Thus concretes tested on different type specimens can only be compared when we know the effect of the type of the specimens . Several investigations have been made in this field, general conclusions drawn by T. Gyengo (1938) are typical and are as follows.

(i) The age of concrete up to 28 days has no effect on the strength relations for the various forms and sizes of test specimens .

(ii) The strength decreases with increasing size of cubes. This decrease is linear in case of mortar and oversanded (70 per cent sand) concretes. The strength relation changes to a curve for concretes with high fineness modulus.

(iii) The strength of square prisms decreases rapidly at first with increasing slenderness ratio, The decrease for 8 ins. prisms is almost fifty per cent for a slenderness ratio of 1:2. Further drop of strength with increasing slenderness is small. For 6 ins. prisms the drop in strength for 1:2 slenderness ratio is only about 30 per cent, but reaches 50 per cent for 1:3 slenderness ratio.

(iv) The compressive strength obtained on 6 x 18 in. cylinders is about 75 per cent of that of an 8 in. cube, and for all practical purposes can be taken equal to the compressive strength of the 6 in. prism of 12 in. length.

(v) The compressive strength of 4 in. prisms with square cross-section and 1:3 slenderness ratio is approximately seventy per cent of the 8 in. cube strength. For 6 in. prisms it is only fifty per cent and for 8 in. prism only slightly higher.

(vi) The strength percentage of both the prisms and cylinders decreased with increasing fineness modulus of the aggregate. The amount of decrease for equally slender specimens is greater for a small than a larger specimen.

(viii) Decrease in the strength percentage with increasing fineness modulus is noticeable also for different size cubes if the largest cube is the basis for comparison. The decrease is greatest for the smaller cubes.

(V) Characteristics of Testing Machine.

After carrying out extensive investigations O.T. Sigvaldason (1966) reported the following conclusions.

(i) Cube strengths are lower when tested with an effectively pinned spherical seating than when tested with an effectively fixed seating. With carefully centred specimens, this difference is about 6%.

(ii) The internal distribution of stresses and the ultimate strength of cubes and cylinders is extremely sensitive to misalignment, if an effectively pinned spherical seating is used. On the other hand, if both ends of the specimen are

effectively fixed, the stress distribution and ultimate strengths are essentially independent of misalignment. In addition, the scatter of strengths will normally be larger with an effectively pinned seating than with an effectively fixed seating. As cube and cylinder strengths should be independent of the small random misalignments which occur in routine testing, it is recommended that the seating tilt freely only during the initial setting-up, becoming fixed as the load is applied to the specimen.

(iii) Cube and cylinder strengths are influenced differently by the method of end loading. With carefully centred specimens differences of 7% occur between loading cubes with both ends pinned and both ends fixed, while the corresponding difference in cylinder strengths is only 1%. Cylinder/cube strength ratios, as a result, are very dependent upon the exact method of end loading.

(iv) The cylinder/cube strength ratio is also very dependent upon the degree of uniformity of the concrete, because of the different directions of testing, in relation to the direction of casting. Where-as the results of cube specimens tested at right-angles to the direction of casting, represent the average strength of the concrete, cylinder strengths indicate the strength of the weakest portion of the material. As a result, cylinder/cube strength ratios are considerably smaller with the naturally

segregating concretes than with uniform concretes.

(v) The longitudinal stiffness of the testing machine has no direct influence upon the ultimate strength of concrete specimens. However, because of the explosive specimen failures which occur with the 'softer' testing machines, resulting in more rapid deterioration of machine components and loss of accuracy, it is recommended that control testing be performed on longitudinally stiff or 'hard' testing machines.

(vi) When the end-blocks of the testing machine are smaller in cross-section than the cube specimen, bending of the platens will result in large reductions in cube strength. It is therefore recommended that the cross-sectional dimensions of the spherical seating or ram should be at least as large as those of the specimen, thereby eliminating completely the possibility of bending at the platens.

2.2. THEORY OF FAILURE.

The mode of failure of concrete as presented by Prof. A.L.L. Baker (1956) is as follows.

Figure 2.3. shows a typical section through a void.

Under pressure applied in the direction indicated the stones will be displaced from the broken-line to the full-line position. Since the stones are very stiff compared with the mortar, their deformation under pressure will be comparatively small. The distribution of the external forces acting on the mortar area ABCDO may be deduced from the deformation of the area from the broken outline to the full outline. The approximate direction and magnitude of these forces are indicated by the arrows, which represent the resultants of normal pressure (or tension) and tangential bond. The principal internal tensile and compressive stresses in the mortar will be distributed roughly as indicated. The stresses are assumed to be proportioned to strains. The magnitude of the strain of a strip of mortar in any direction is the change of length of the strip divided by the original length. In the neighbourhood of B.C. some crushing may take place, with greatly increased strains in relation to stress. The tension in the mortar is mainly due to the outward

displacement of stones on either side of the void in the direction OD. A secondary strain is caused in the mortar by the pressure and may be defined by Poisson's ratio for mortar; it partly accounts for the displacement in the direction OD, though the principal cause of this is the diagonal compression at BC.



It is evident that, failure by tension in the voids is generally the primary cause of failure, and that concentrated pressures or tensions tend to spread into the structure at an angle of about 45 degrees on either side of the direction of application; thus explaining the characteristic cube failure. The friction in the bearing plates applies an inward compression which reduces the tension near the plates and towards the centre of the cube. Failure is initiated by the cracking of the mortar in the zones of maximum tension. When prisms or cylinders are tested with frictionless bearing plates, splitting failure occurs, since there is no transverse friction force opposing the tensions due to pressure.

Bond between mortar and stone helps to reduce the tension in voids by resisting deformation and is, therefore, important.

Bond failure also releases tension and therefore can initiate failure of tensile resistance. The bond characteristics of stones are, therefore, important.

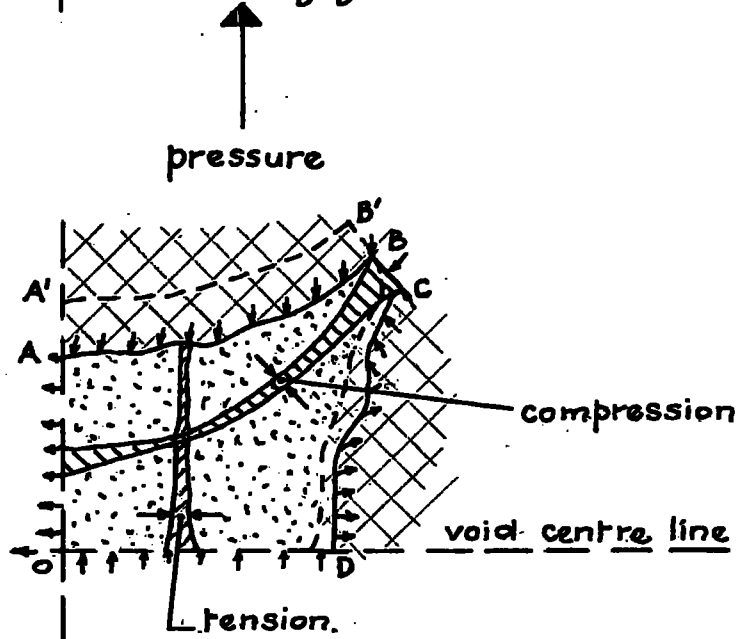
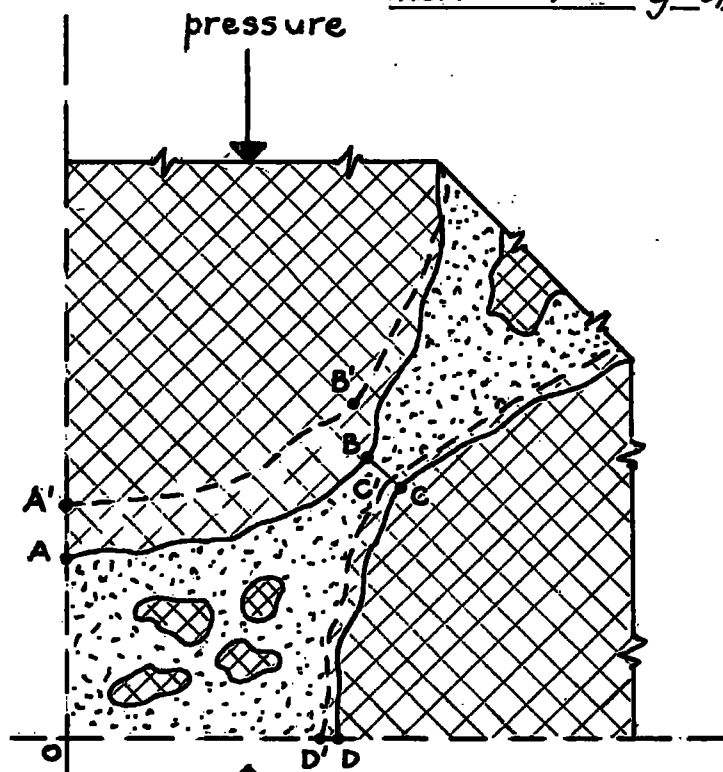
Fig. 2.3. Deformation and forces acting on the mortar filling of a void.



- ⊕ void
-  stone
-  mortar
- uncompressed
- compressed

CHAPTER 3. INVESTIGATIONS CARRIED OUT

3.1 INTRODUCTION.

The aim of the investigations was to determine the effect of hydrostatic pressure, applied during setting, on the strength of concrete.

Due to the limited time available the scope of the investigations was restricted to that of a few tests, the main object of which was to form a basis from which future work could be evolved.

The actual tests which were carried out, were designed not only to study the effect of pressure but the effect of intensity and time of application of pressure.

3.2 THEORETICAL REASONING BEHIND ADOPTION OF PROCESS BEING INVESTIGATED.

As explained in Chapter 2, many factors affect the ultimate crushing strength of concrete, one of these being the bond-strength between the aggregate and mortar interfaces, failure of which can initiate the ultimate failure of the concrete.

After carrying out extensive research work, Thomas T.C. Hsu, Floyd O. Slate, Gerald M. Sturman, and George Winter (1963) presented the following results:-

(i) Microcracks can be divided into three types, cracks at the interface between aggregate and mortar (bond cracks), cracks through the mortar, and cracks through the aggregate.

(ii) Bond cracks exist even before the concrete is subject to any load, while the mortar cracks remain negligible until a later loading stage.

(iii) The total extent of mortar cracking is considerably less than that of bond cracking at all stages of straining.

From the above results it can be concluded that the bond between the aggregate and mortar interfaces is the weakest link in the heterogeneous concrete system. It was with this in mind that prompted the adoption of the process being investigated as one which would be beneficial to the ultimate crushing strength of concrete, the reason being as follows.

The application of a hydrostatic pressure will squeeze the aggregate particles and mortar together, thus reducing and possibly eliminating the micro-bond cracks, and since the pressure will be applied during setting of the concrete, it is hoped that a substantial increase in the crushing strength of the resulting concrete specimens will follow.

3.3 APPARATUS.

The apparatus for processing the concrete is shown in figures 3.1 to 3.6 inclusive and basically consists of a mould capable of producing six cylindrical specimens in one operation. The pressure is applied to the specimens through six pistons which are located on a centralised plate, load being applied to the plate by means of a hydraulic jack. To maintain the vacuum, "O" sealing rings were incorporated in the pistons, and also before each test all joints in the mould were well greased before assembly. It was also found necessary to incorporate a gasket between the mould and the mould baseplate. The suction was obtained by means of a rotary pump capable of producing 98% vacuum. The suction was applied to the base of each specimen via small holes in the mould baseplate, these being connected to the pump by means of reinforced tubing, a vacuum gauge being incorporated in the system. Loss of material particles from the mould due to the suction was prevented by placing sintered brass discs at the base of each specimen mould.

Vibration was obtained by clamping the apparatus to a vibrating table.

The cylindrical moulds were limited in size to 2 inches diameter in order that reasonably high pressures could be applied to the specimens, and also that a reasonable number i.e. six, could be obtained in each operation of the apparatus for testing requirements.

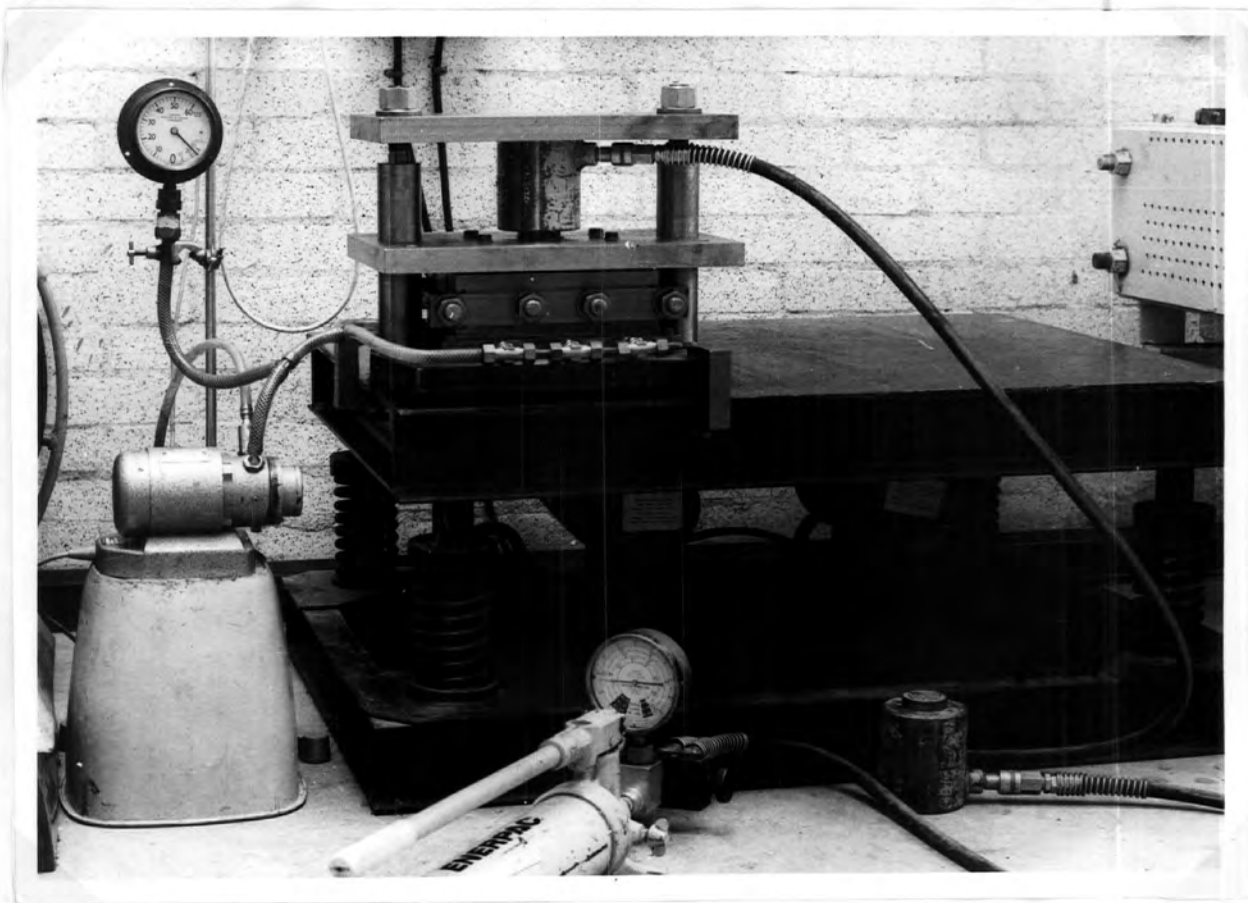

FIG. 3.1. GENERAL VIEW OF PROCESSING APPARATUS
IN OPERATION.

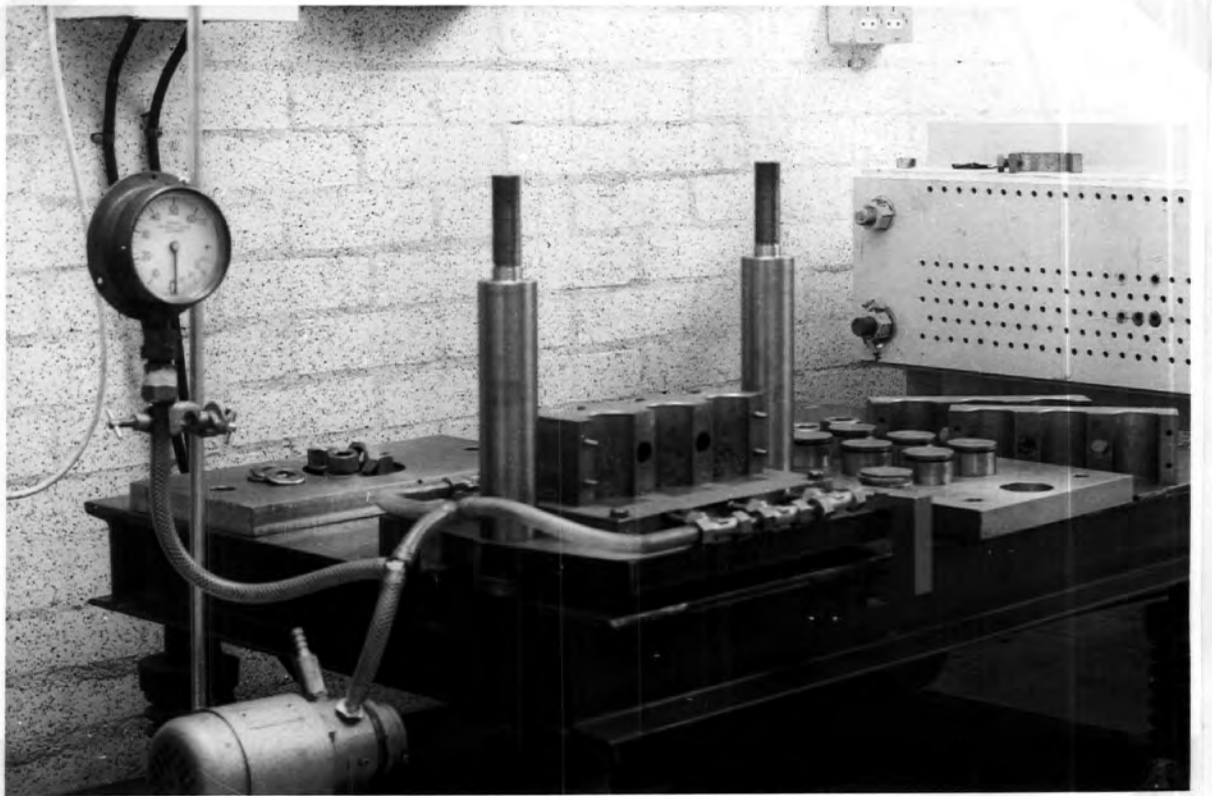

FIG. 3.2. GENERAL VIEW OF DISMANTLED PROCESSING
APPARATUS.

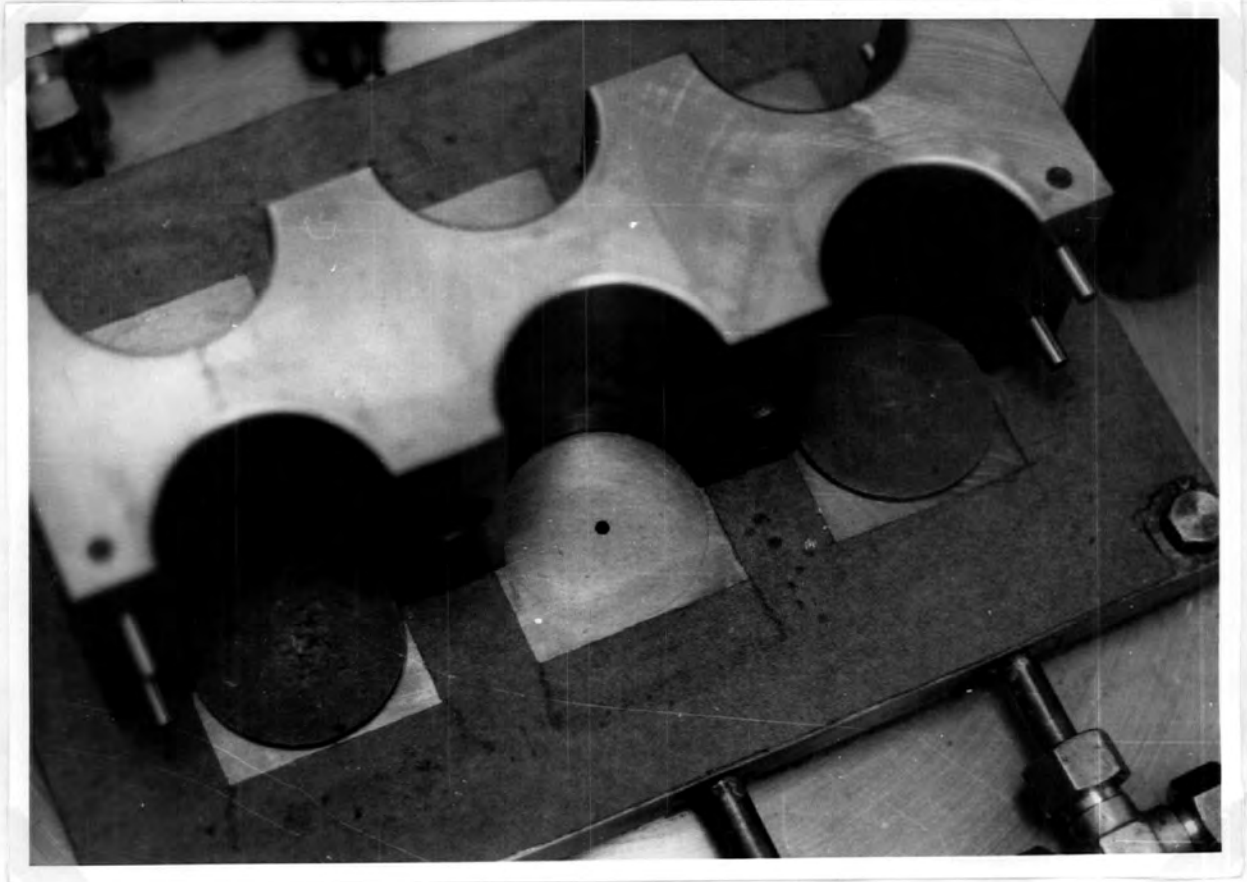

FIG. 3.3. VIEW OF DISMANTLED MOULD SHOWING THE SMALL HOLES THROUGH WHICH THE SUCTION WAS APPLIED, THE SINTERED BRASS DISCS USED TO PREVENT LOSS OF MATERIAL, AND THE GASKET PLACED BETWEEN THE MOULD AND THE MOULD BASEPLATE TO PREVENT LOSS OF VACUUM.

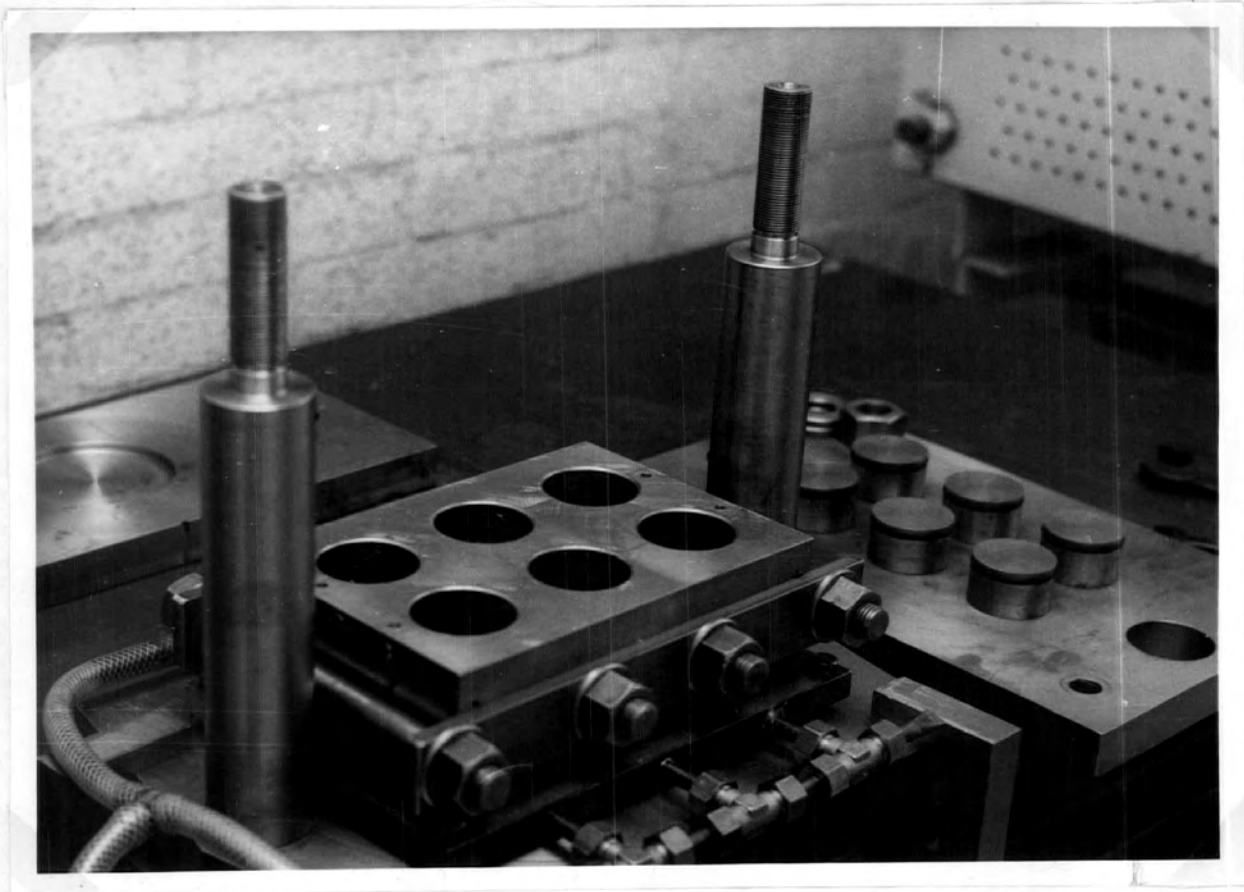

FIG. 3.4. ASSEMBLED MOULD.

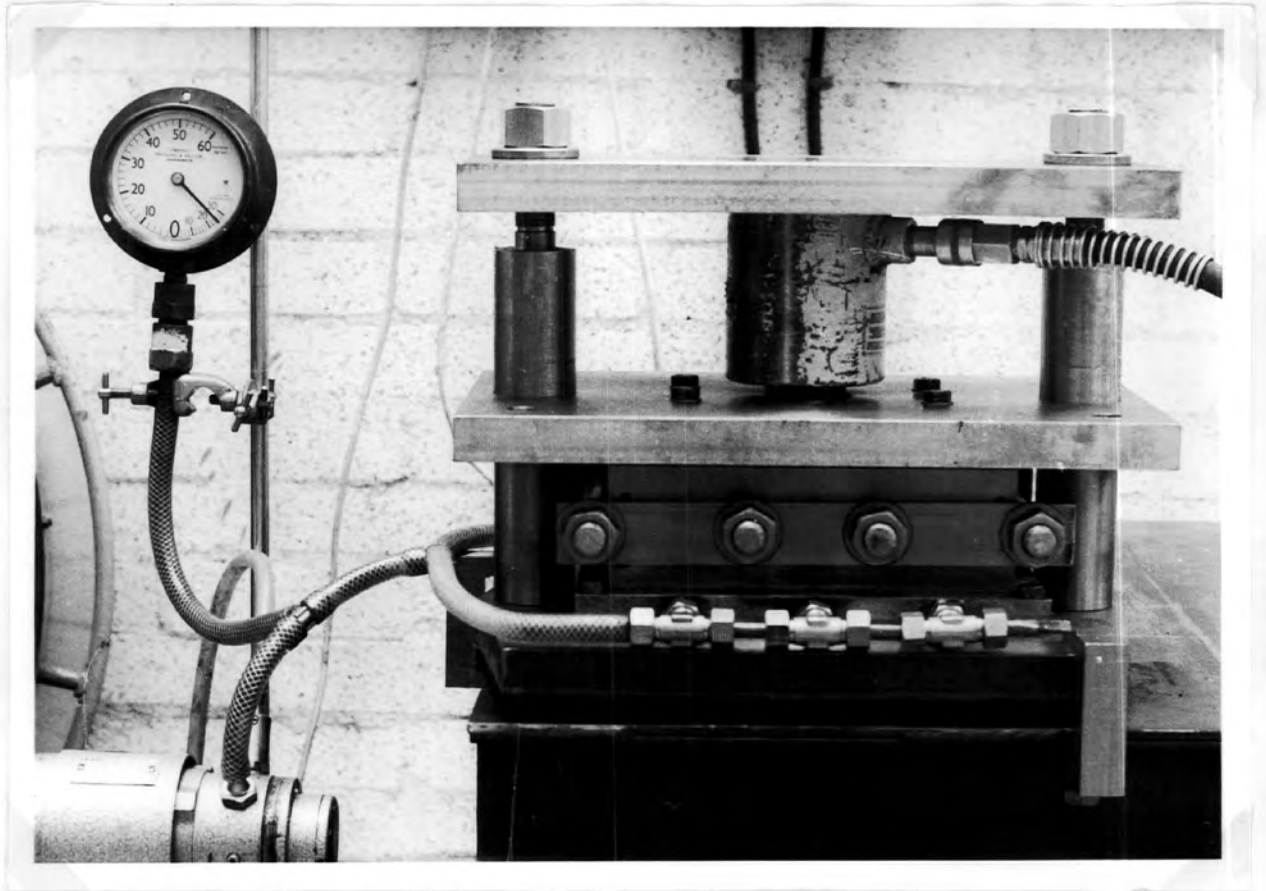

FIG. 3.5. GENERAL VIEW OF ASSEMBLED APPARATUS
IN THE STAGE OF PROCESSING A SET OF
SPECIMENS.

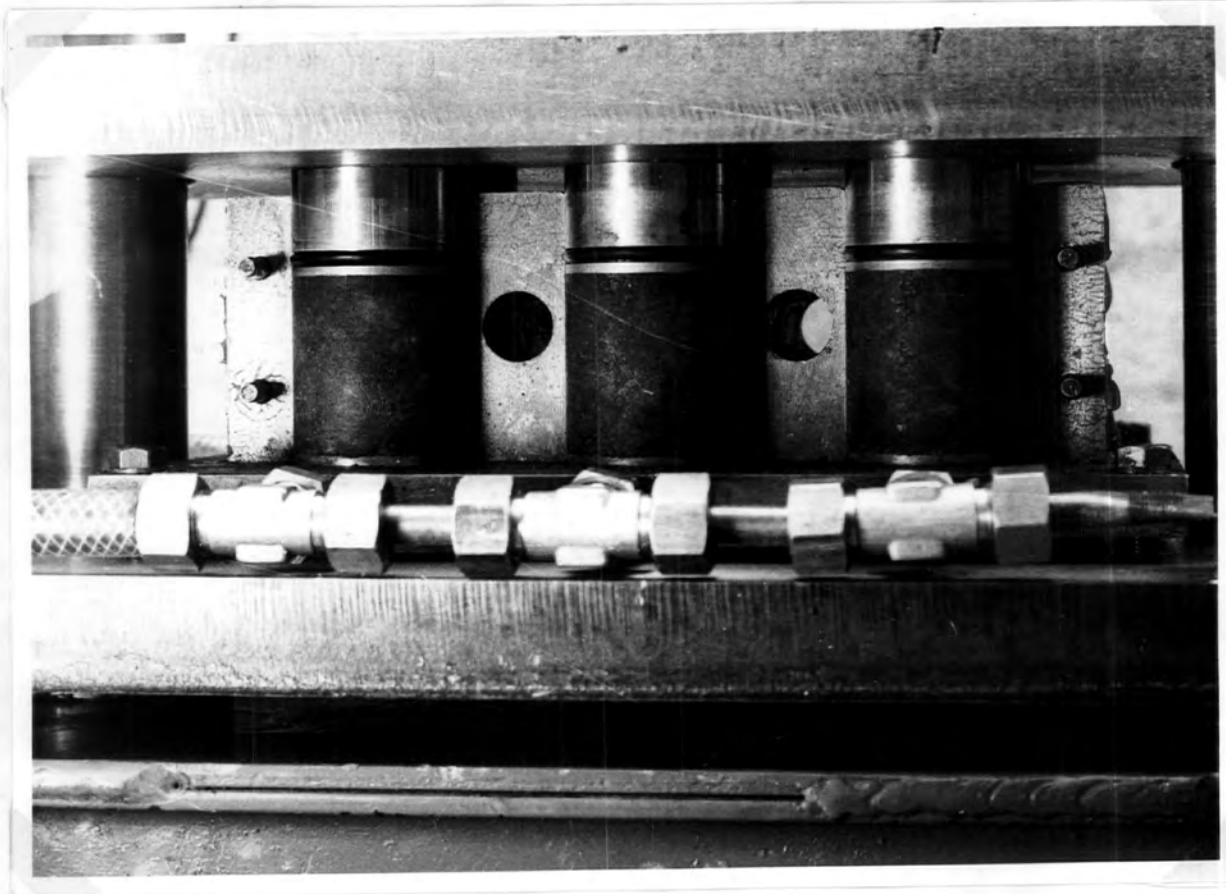

FIG. 3.6. PARTLY DISMANTLED APPARATUS AND RESULTING
PROCESSED SPECIMENS.

3.4 METHOD.

After carrying out trial tests the following two conclusions were drawn.

- (i) It was found that better results were obtained when the pressure and suction were accompanied by vibration. This conclusion substantiates those drawn by J.B. Garnett (1959) who carried out similar tests on vacuum processed concrete, without application of pressure. Explanation of this, as given by Hawkes, is that the vibration maintains the concrete in a "fluid state", thus enabling the atmospheric pressure (or applied pressure) to act with the vibration in forcing the particles into closer contact, and thus a higher strength concrete is produced.
- (ii) Relatively high water/cement ratios had to be adopted in order that a smooth surface could be obtained on the face of the specimen and thus a uniform pressure was ensured throughout the specimen. Figure 3.7 shows a typical specimen of low water/cement ratio. These specimens were disregarded since the resulting irregular face is obviously detrimental to the process being investigated since only point loadings were obtained on the face of the specimen in the mould.



FIG. 3.7. TYPICAL PROCESSED SPECIMEN RESULTING
FROM A MIX OF INITIAL LOW WATER/CEMENT
RATIO.

It was on the above findings that the following method was based.

The weight of concrete required to fill each cylindrical mould was recorded. After filling, the moulds were vibrated for 3 minutes; this was necessary in order that intimate contact between the concrete and the sides of the mould was obtained, and also, as stated above, that a smooth face was obtained on the specimens before the pressure was applied. For approximately the last 30 seconds of this period of vibration, suction was applied to the specimens. This was found necessary in order to remove some of the excess "free" water which had been formed due to the vibration, and which, due to its incompressibility was found to break the sealing between the mould joints when the pressure was applied.

Pressure, suction and vibration were then simultaneously applied to the specimens. For all tests the suction and vibration were terminated after 20 minutes. Tests were carried out using three variations of intensity of pressure (Test Series A), each pressure being applied for a period of 20 minutes (i.e. pressure removed at same time as suction and vibration) and 24 hours (Test Series B).

In all cases the moulds were stripped after 24 hours , the specimens being weighed and then stored in water at a constant temperature of 65° F. until tested.

From the initial weight of material placed in the mould and the weight of the specimen on removal from the mould, the amount of water removed from each specimen was deduced, and assuming a uniform mix the final Water/cement ratio for each specimen was calculated.

To evaluate the effect of the suction, cylindrical specimens were made using the same procedure except that the pressure was omitted. To evaluate the effect of the process, cylindrical control specimens were made, these being the same diameter as the processed specimens.

Both test series were carried out using a 3/16" and a 5/8" maximum size aggregate. In the case of the 5/8" aggregate, 4 inch control cubes were also made, and a cylinder/cube ratio was evaluated, thus enabling the results of the processed cylinders to be more realistically compared to results that would be obtained if the process was to be used in practice.

In all cases all control specimens were vibrated for a period of time varying from 2-3 minutes, the time depending

upon the workability of the mix concerned.

Typical stages in the manufacture of a set of specimens are shown in Figs. 3.8 to 3.12 inclusive, a typical set of resulting specimens being shown in Fig. 3.13.

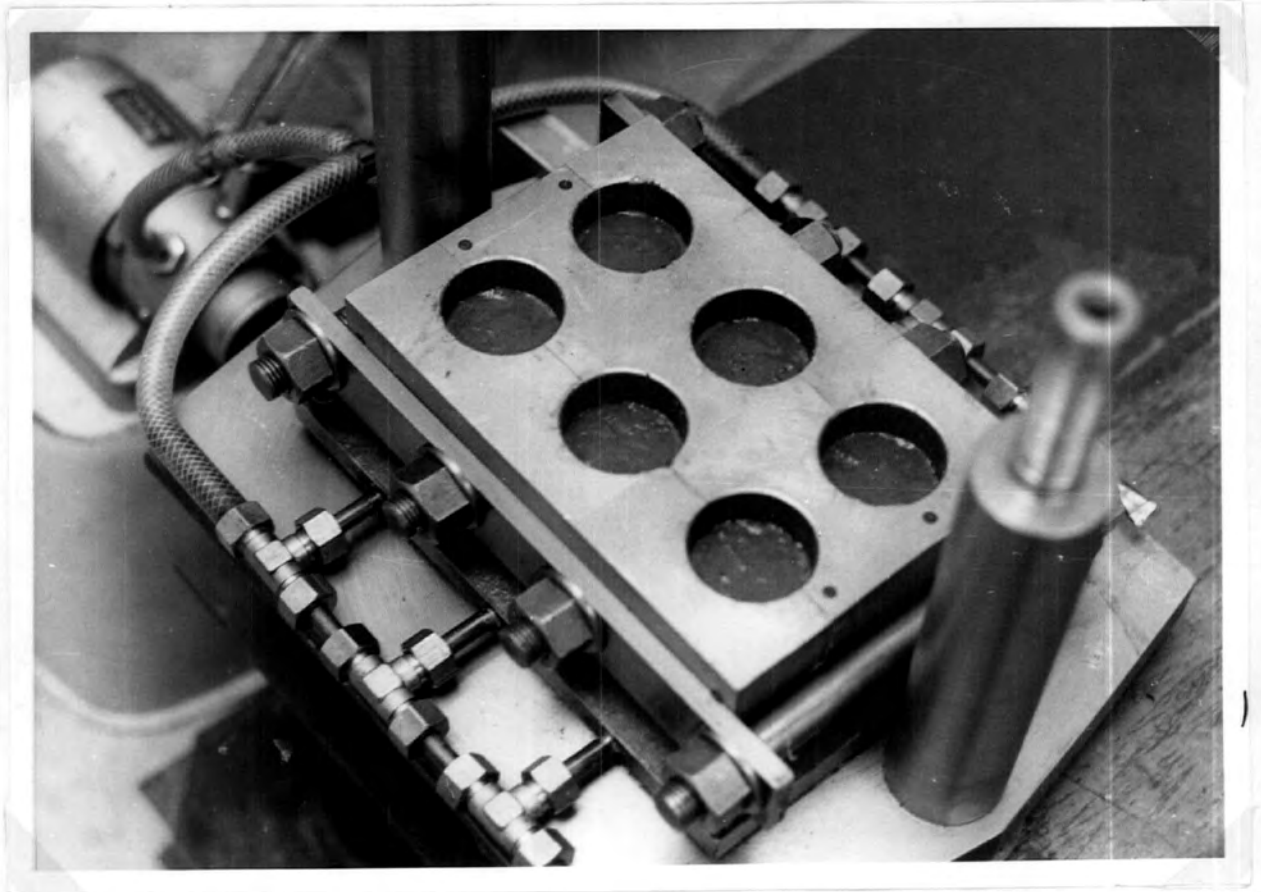

FIG. 3.8. INITIAL VIBRATION PERIOD BEFORE SUCTION
AND PRESSURE ARE APPLIED.

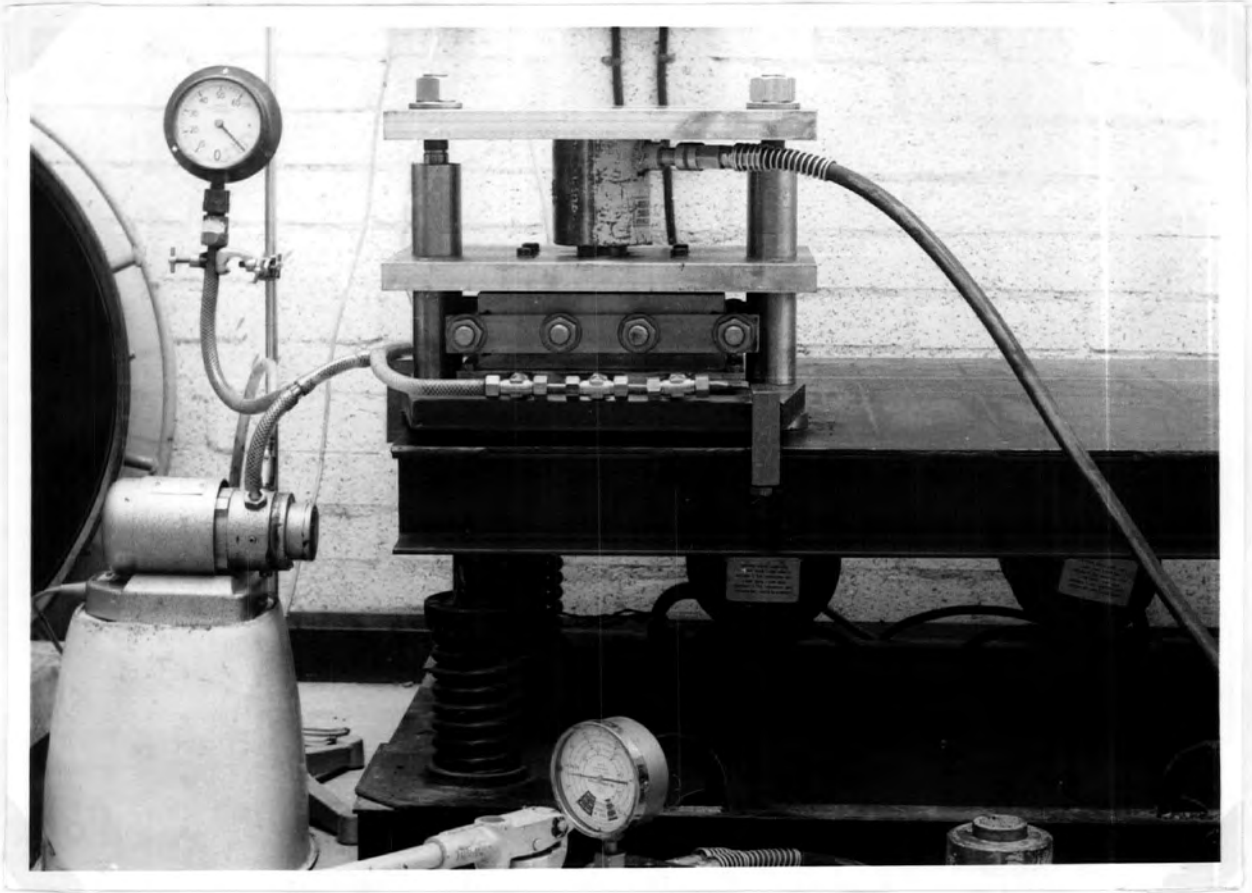

FIG. 3.9. APPLICATION OF PRESSURE, SUCTION, AND VIBRATION.

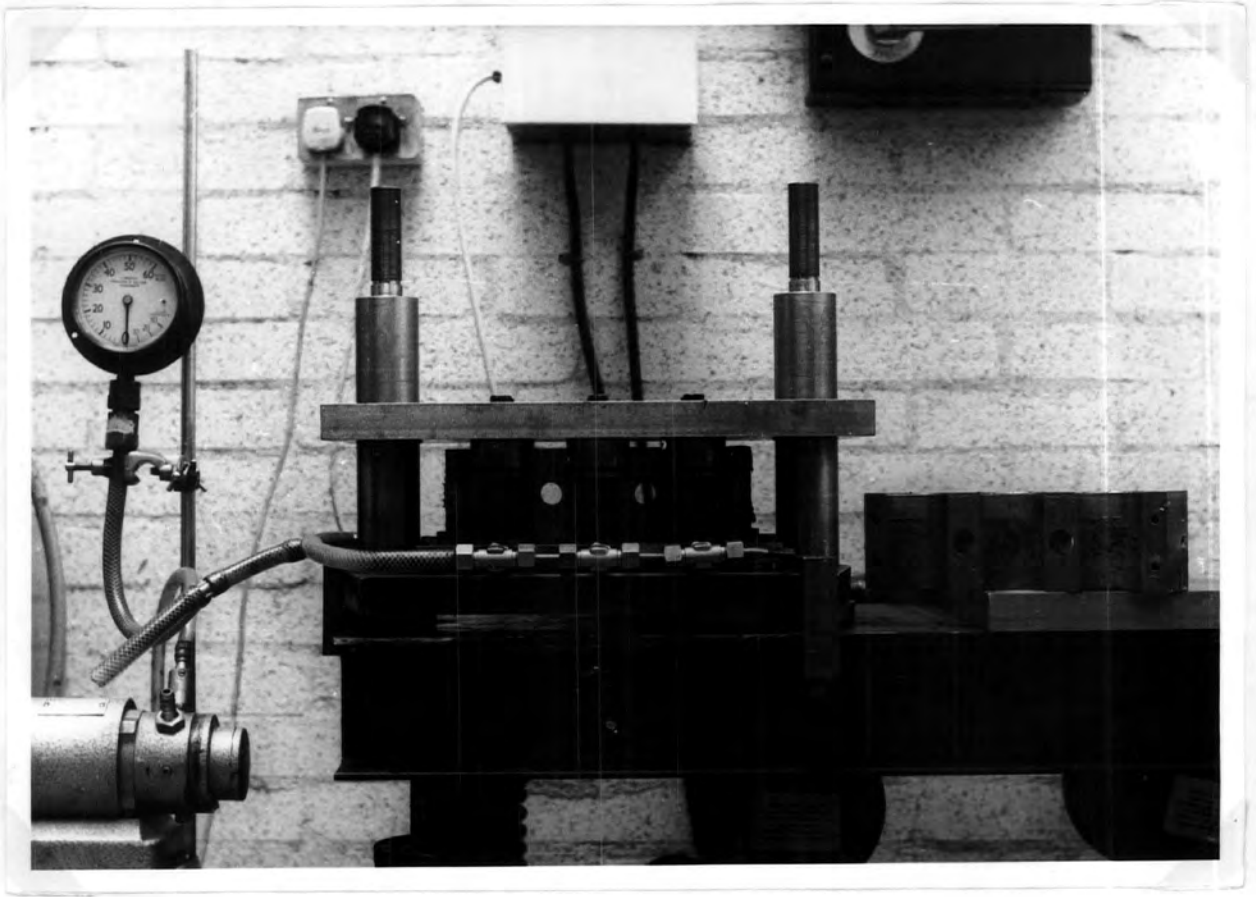

FIG. 3.10. DISMANTLING OF APPARATUS 24 HOURS
AFTER PROCESSING.

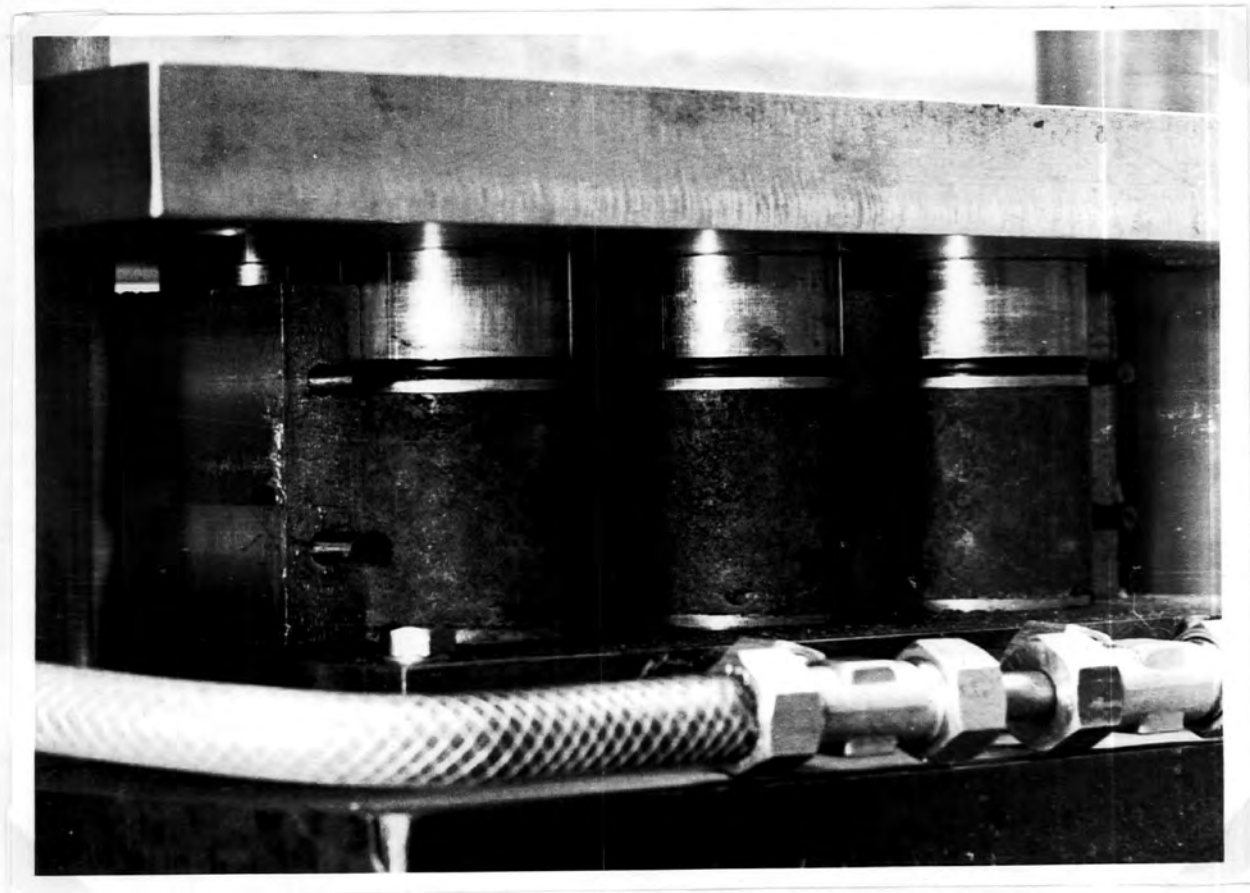

FIG. 3.11. VIEW OF THE PROCESSED SPECIMENS DURING
DISMANTLING OF THE APPARATUS.

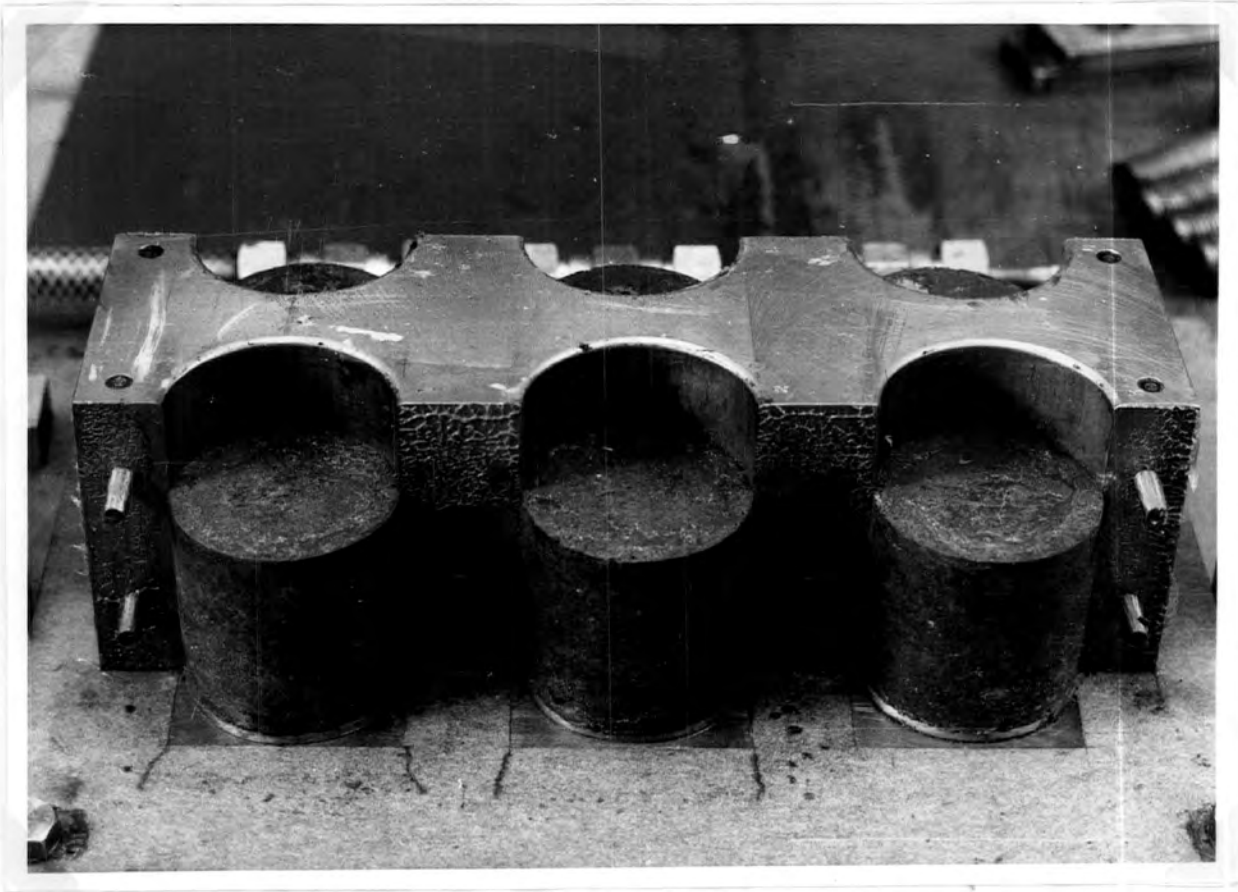

FIG. 3.12. TYPICAL SET OF PROCESSED SPECIMENS BEFORE
BEING REMOVED FROM THE MOULD.

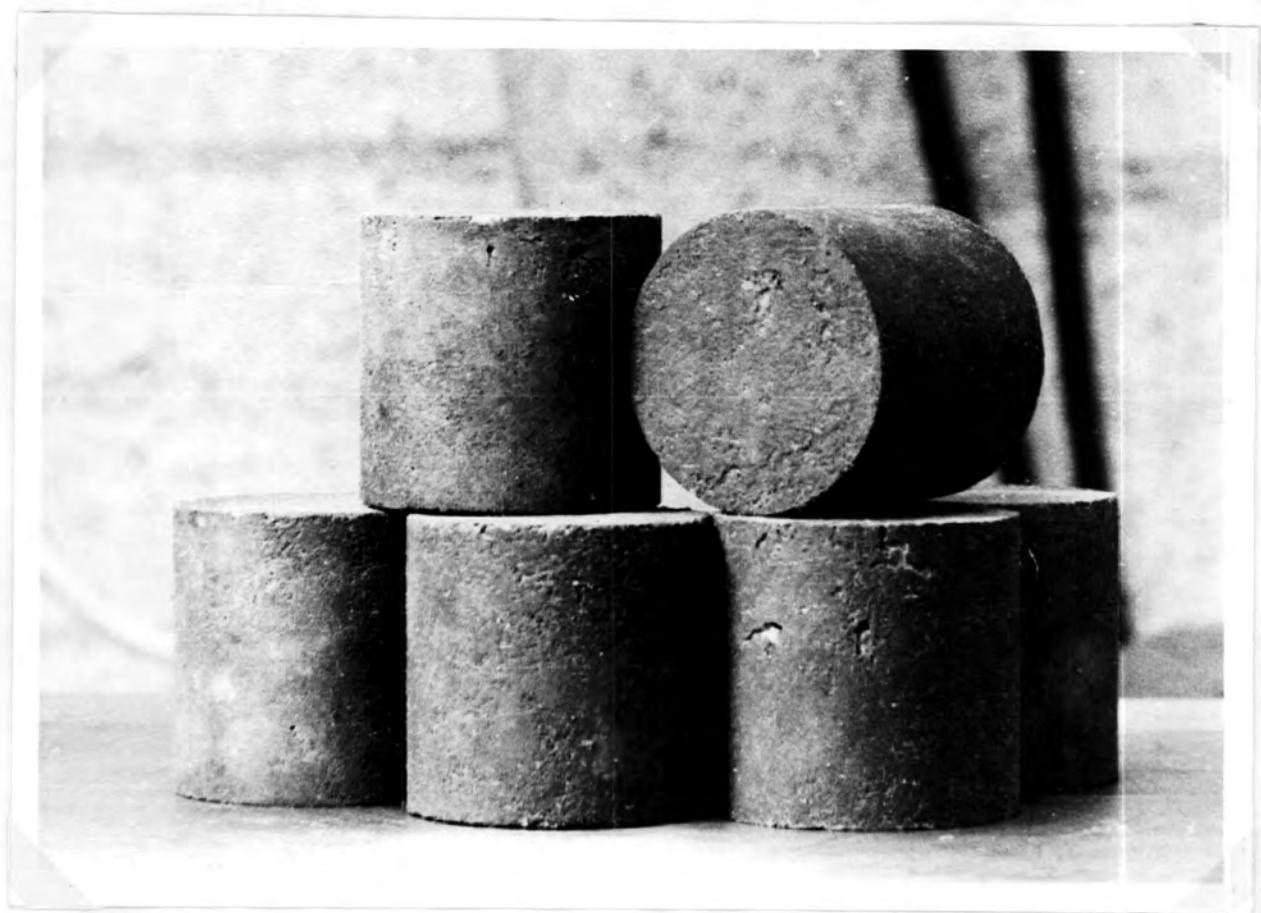

FIG. 3.13. TYPICAL SET OF PROCESSED SPECIMENS.

3.5 SELECTION AND GRADING OF AGGREGATE.

Since the specimens were limited in size to 2 inches diameter, the choice of the maximum size aggregate was accordingly limited to that of the smallest possible size thought to be practical, the choice being that of a 3/16" irregular shaped "Dolerite" aggregate, results of selected tests on which are shown in Table 3.1, a typical sample being shown in Fig. 3.14.

Fig. 3.15 shows the "all-in" grading of the aggregate as it was received. From this curve it can be seen that for workability purposes the grading possessed an excessive amount of fines and that a "gap-graded" aggregate containing the maximum percentage of top-size aggregate for maximum compacted bulk density would have to be adopted if the best results were to be obtained. To obtain this grading, a graph of Compacted Bulk Density against Percentage Top-size Aggregate was plotted and is shown in Fig. 3.16. As can be seen from the curve the maximum percentage top-size aggregate was found to be 75, the resulting gap-grading of the aggregate being as shown in Fig. 3.17 and as detailed below.

75.00% Retained on No. 7 Sieve (Top-size i.e. 3/16")

9.72% " " No. 52 "

4.80% " " No. 72 "

3.70%	Retained on No. 100 Sieve
5.20%	" " No. 170 "
1.58%	" " No. 200 "

Since a 3/16" maximum size aggregate is somewhat unusual and rarely used in practice, a classification of strength against water/cement ratio with varying aggregate/cement ratio was carried out, the result of which is shown in graph form in Fig. 3.18 and can be summarised as follows:-

- (i) With a constant water/cement ratio the workability and hence ease of compaction of the mix decreased as the aggregate/cement ratio was increased. This result was as expected since an increase in aggregate/cement ratio decreased the cement content and thus with a constant water/cement ratio there is a decrease in the water content and hence a decrease in the workability of the mix and an increase in the compactive effort required to achieve full compaction.
- (ii) Similarly, for a constant aggregate/cement ratio, a decrease in water/cement ratio decreases workability, this decrease reaching a stage where full compaction could not be obtained, thus causing a decrease in the crushing strength of the mix. This "fall-off" in strength occurred at a higher water/cement ratio for the lean mixes (high aggregate/cement ratio), than for the rich mixes (low aggregate/cement ratio); the reason for this being as explained in (i) above.
- (iii) As can be seen from the graph, only low crushing strengths were obtained, the maximum being that of 56.

7000 lbf/sq. ins. at 28 days using a water/cement ratio of 0.40 and an aggregate/cement ratio of 4:1 This value could have been increased by further lowering of the aggregate/cement ratio, thus increasing the workability and allowing a further decrease in the water/cement ratio before the mix became unworkable.

(iv) From the results obtained, it is apparent that the size and irregular shape of the aggregate was the most influencing factor on the crushing strengths obtained, this being due to its pronounced effect on the workability of the mix, the mix becoming unworkable at a relatively high water/cement ratio even when a low aggregate/cement ratio was adopted. This effect of aggregate size and shape is explained in "Factors Affecting Concrete Strength" in Chapter 2 and from the results obtained it appears that in this instance the advantages of using a small aggregate size is more than offset by the disadvantages of the additional water which is required for workability of the mix.

Upon completion of Test Series A and B. using the above aggregate it was decided to repeat the series using a larger size. The size of the processing moulds again restricted the choice, but it was thought that a $\frac{3}{8}$ " maximum size

aggregate of the same type as used above, along with sand as the fine aggregate, would be acceptable. The "gap-grading" of the aggregate is as shown in Fig. 3.19, a typical sample being shown in Fig. 3.14, selected tests on the sand being shown in Fig. 3.20.

Test Series B1 was carried out using the same $\frac{3}{8}$ " aggregate and fine sand, the grading being slightly different and as shown in Fig. 3.21.

TABLE 3.1. SELECTED PHYSICAL PROPERTIES OF THE
"DOLERITE" AGGREGATE USED IN THE INVESTIGATIONS

AVERAGE SPECIFIC GRAVITY ON AN OVEN DRIED BASIS	2.93
AVERAGE SPECIFIC GRAVITY ON SATURATED BASIS	2.96
AVERAGE APPARENT SPECIFIC GRAVITY	3.02
AVERAGE WATER ABSORPTION (% of dry weight).	1.03
PERCENTAGE CLAY, FINE SILT, AND DUST (Carried out on sample of aggregate as it was received i.e. as per Fig.3.15.)	7%

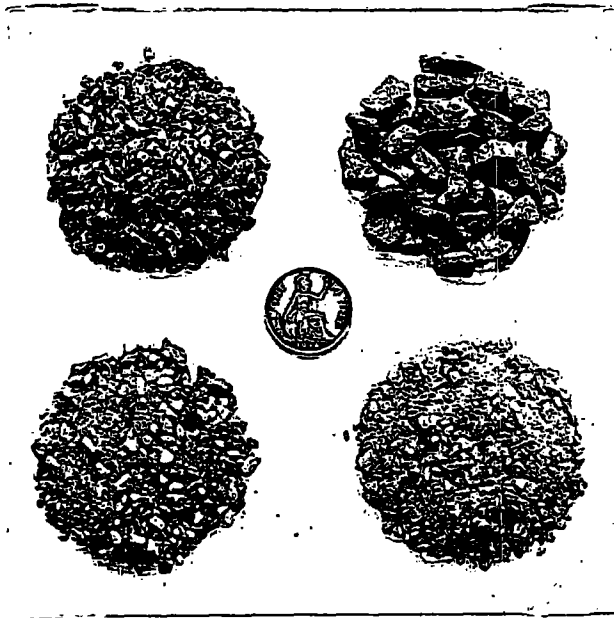

Top Left: Sample of single size
3/16" "Dolorite" aggregate.

Top Right: Sample of single size
3/8" "Dolorite" aggregate.

Bottom Left: Sample of 3/16" Sand.

Bottom Right: Sample of 3/16" aggregate
as it was received.



Top: 3/8" "Dolorite" aggregate.

Bottom: 3/16" "Dolorite" aggregate.

FIG. 3.14. TYPICAL SAMPLES OF THE AGGREGATES USED
IN THE INVESTIGATIONS.

B. S. Sieve Mesh Numbers.

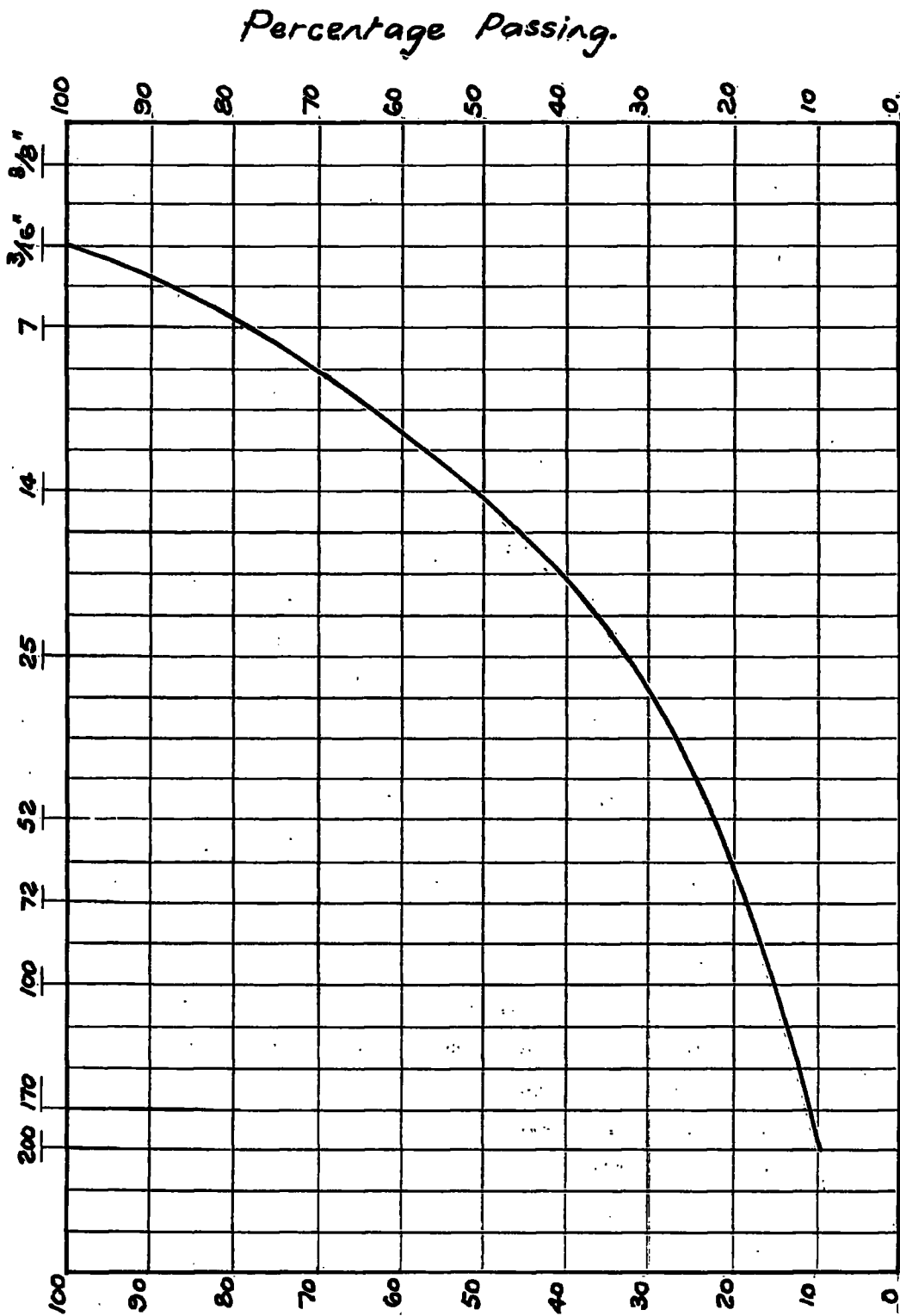

Fig. 3.15. "All-in" Grading of 3/16" aggregate.

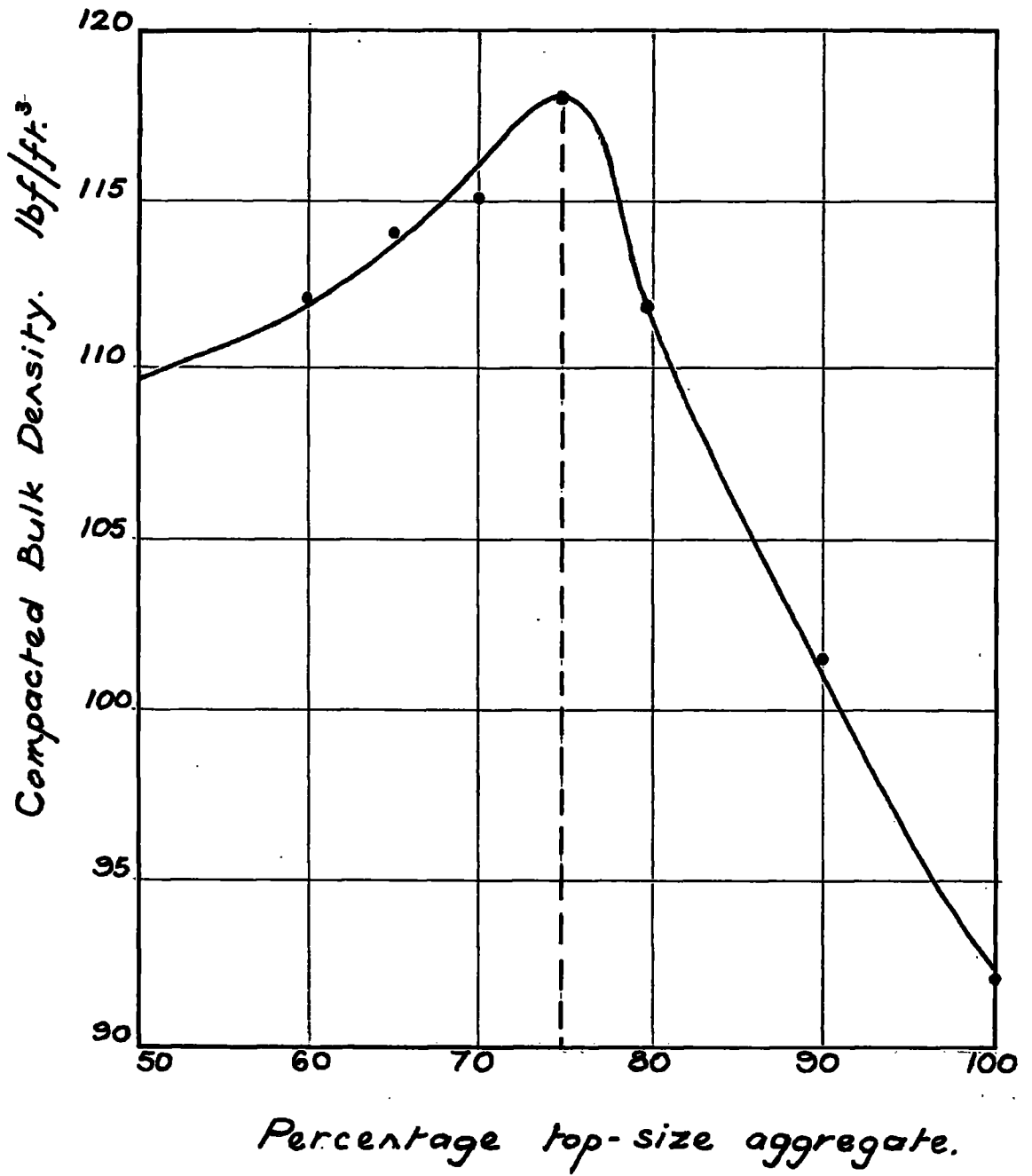

Fig. 3.16.

B.S. Sieve Mesh Numbers.

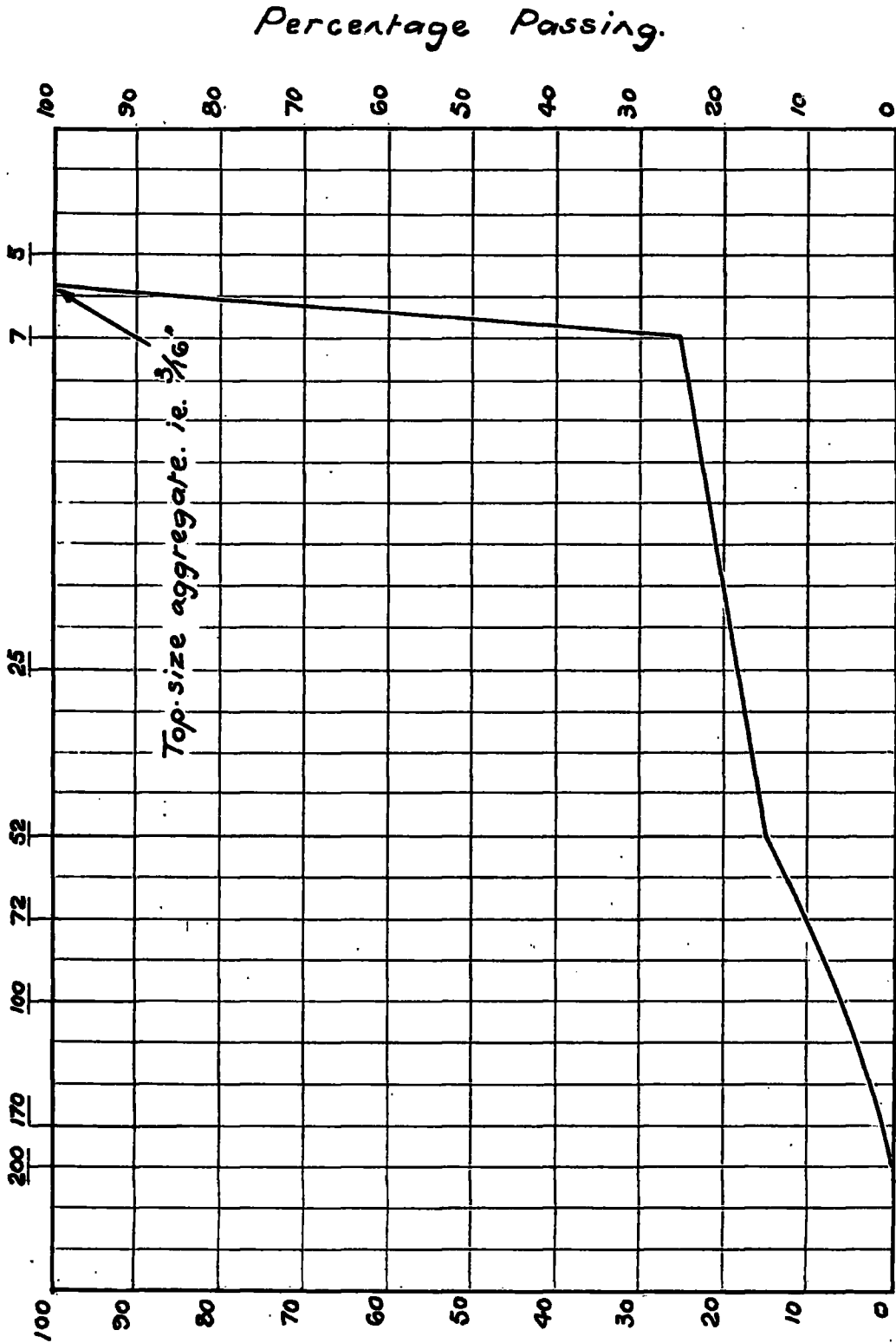
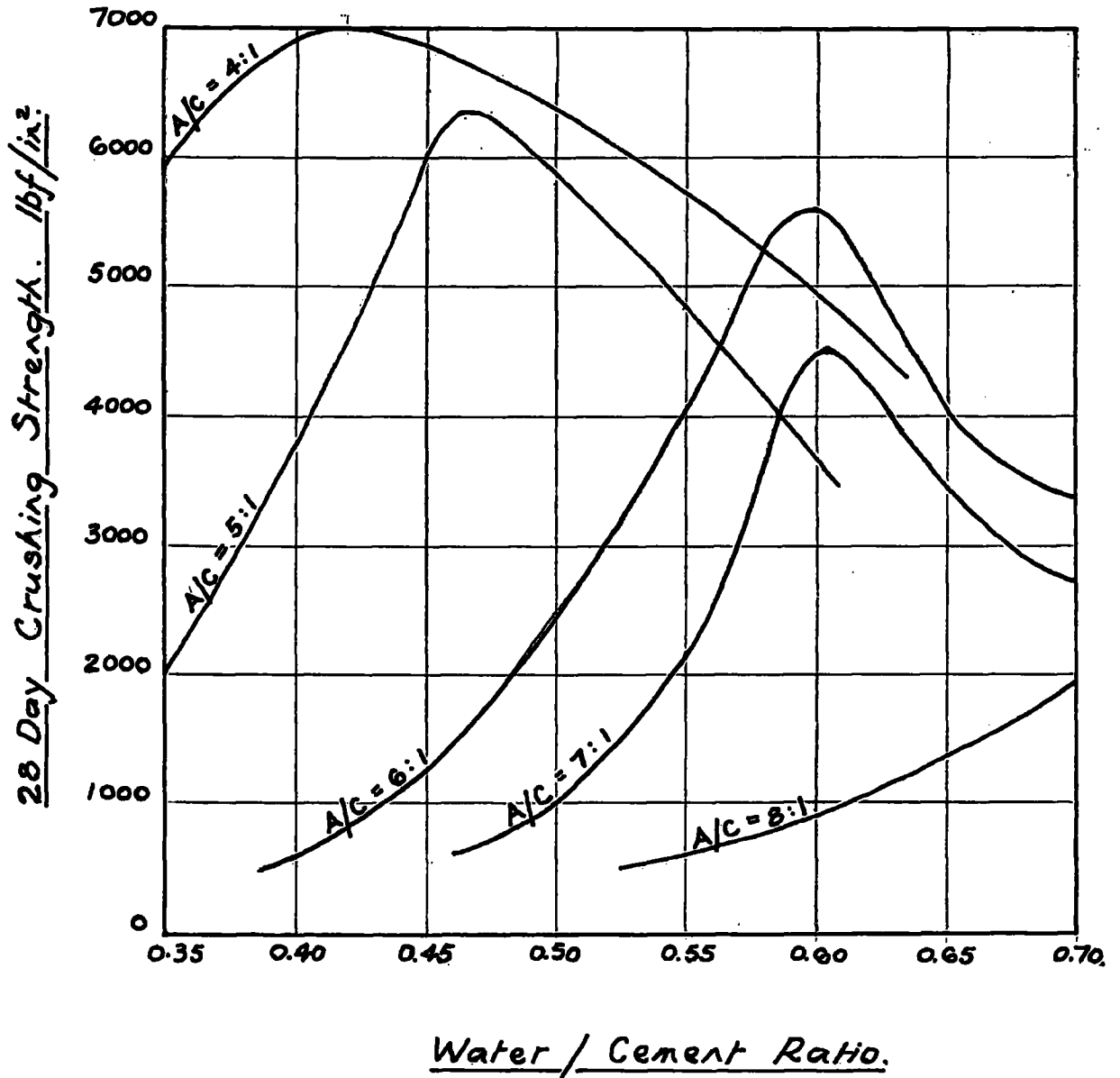

Fig. 3.17. Gap-Grading of aggregate for mixes "A1"

Fig. 3.18. Water / Cement v Crushing Strength
for varying aggregate / cement ratios.



Note: For details of aggregate grading
 see Fig. 3.17.

Percentage Passing.

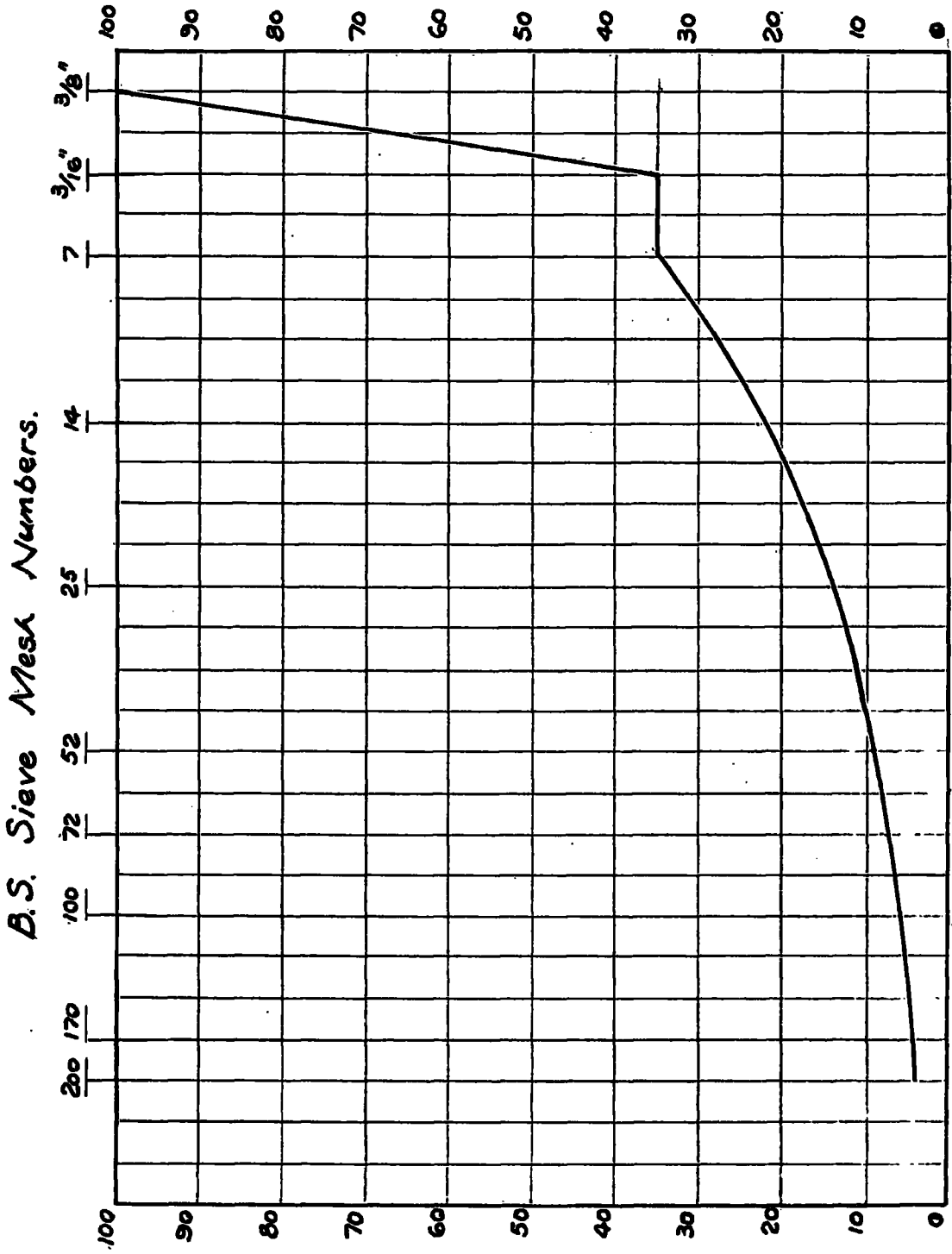

Fig. 3.19. Grading of aggregate for mixes "B1", "B2", and "B3".

TABLE 3.20. SELECTED PHYSICAL PROPERTIES OF THE SAND
USED IN THE INVESTIGATIONS

AVERAGE SPECIFIC GRAVITY ON AN OVEN DRIED BASIS	2.54
AVERAGE SPECIFIC GRAVITY ON SATURATED DRY BASIS	2.64
AVERAGE APPARENT SPECIFIC GRAVITY	2.83
PERCENTAGE CLAY, FINE SILT AND DUST	
AVERAGE WATER ABSORPTION (% of dry weight).	4.04

B.S. Sieve Mesh Numbers.

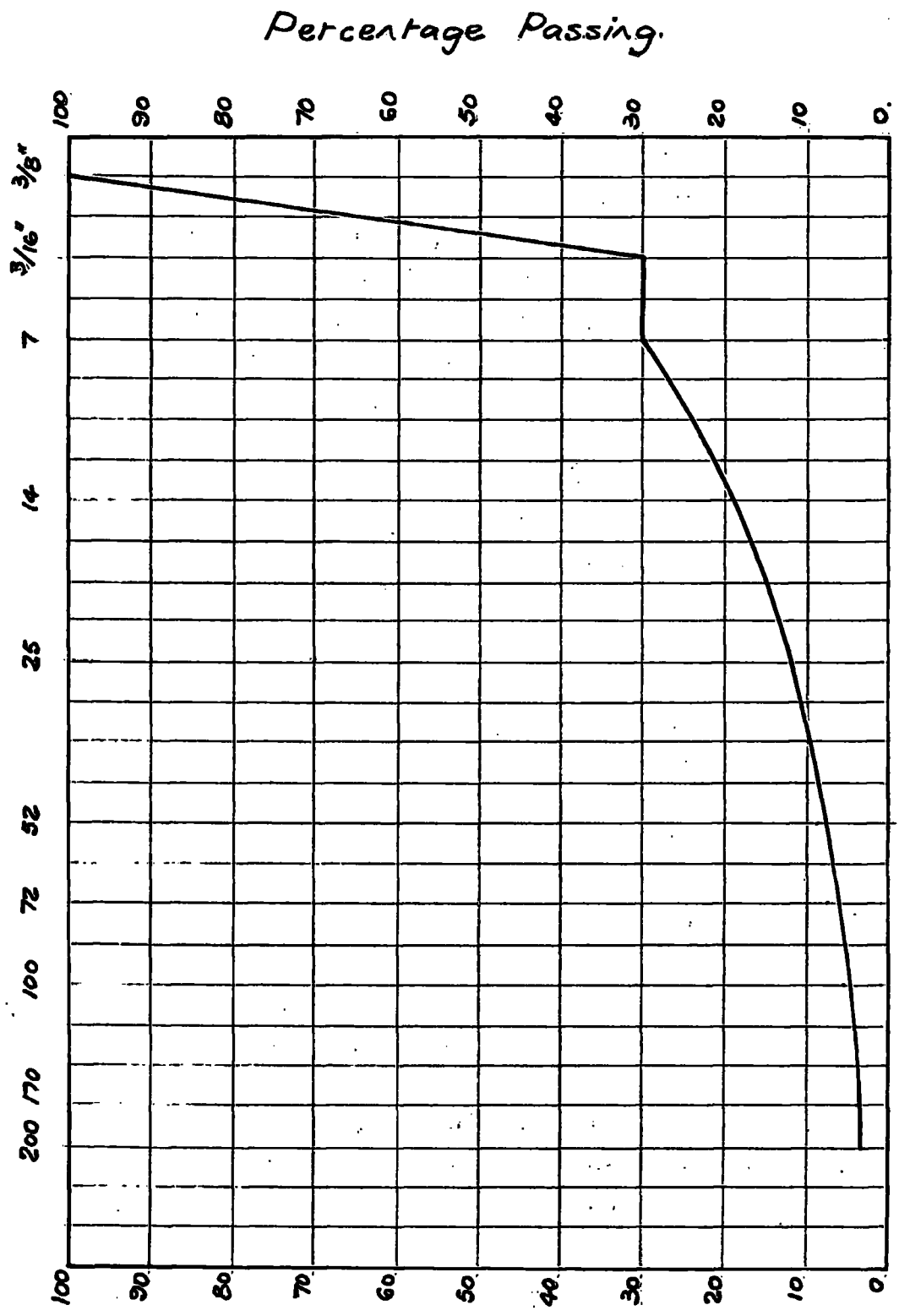

Fig. 3.21. Gap Grading of aggregate for mix "B4"

3.6 TEST SERIES.

Two series of tests were carried out.

Series A: To study the effect of variations in intensity of pressure.

Series B: To study the effect of variations in time of application of pressure.

Series Bl: An extension to Series B.

Both test series were carried out using two different maximum size aggregate, these being 3/16" and $\frac{5}{8}$ ", details of selected tests and gradings being given in Section 3.5, details of the mixes used being given in Section 3.7.

Ordinary Portland cement was used for Series A and B, Rapid Hardening cement being used for Series Bl.

Series A: Variations of Intensity of Pressure.

Three values of pressure were used, 555, 1110 and 3330 lbf/sq. ins., all of which were applied for a period of 20 minutes (for procedure see section 3.4). For the 555 and 1110 lbf/sq. ins. pressures it was possible to make six specimens in each operation of the apparatus. In the case of the 3330 lbf/sq. ins. pressure the load capability of the apparatus restricted the number of specimens which could be made to two. This was achieved by making the four

corner moulds of the apparatus redundant and using the remaining two. Since these two remaining moulds were central about the position of the applied load, it was ensured that equal pressure was applied to each specimen.

Specimens were made using one mix for the 3/16" aggregate, mix reference A1, and three varying mixes for the 3/8" aggregate, mix references B1, B2 and B3. (for details of the mixes see section 3.7). Due to the limited time available only one set of specimens were made for each pressure; the pressure range for mixes B2 and B3 being uncompleted.

The results for the above specimens, along with the results for the control cubes, control cylinders and "suction only" specimens, are given in Chapter 4, Table 4.1 and are discussed in section 4.2

Series B: Variations of Time of Application of Pressure.

Due to the limited time available it was decided to repeat the tests which were carried out under Series A, the pressures in this instance being applied for a period of 24 hours instead of 20 minutes. Since these specimens were made using the same three pressures, the 24 hour pressure specimen results are shown as Series A results in Table 4.2, the 20 minute and 24 hour Series A results being shown together in Table 4.3 as Series B results.

Series B1: An extension to Series B.

A research project by D.W.K. Preston, a departmental undergraduate, formed an extension to Series B, a summary of this work being as follows.

Specimens were made using a constant pressure of 1600 lbf/sq. ins. applied for three variations of time, these being 20, 60 and 600 minutes; the vibration and suction in all cases being terminated at 20 minutes. All specimens were "tamped" and vibrated for 5 minutes before the pressure and suction were applied. Only four moulds of the apparatus were used for processing, the remaining two moulds were used for "control" specimens (no suction or pressure), the "Control" specimens were therefore subject to a period of vibration of 25 minutes.

Only one mix was used throughout the tests, details of which are given in section 3.7., the mix reference being B4.

The results for this series of tests are shown in Table 4.4 and discussed in section 4.2 of Chapter 4.

3.7. DETAILS OF MIXES

Mix Reference A1

Coarse Aggregate: None
Fine Aggregate: "Dolerite" of maximum size 3/16",
a sample being shown in Fig.3.14.
Aggregate Grading: See Fig. 3.17.
Water/Cement Ratio: 0.65
Aggregate/Cement Ratio: 4:1

Mix Reference B1

Coarse Aggregate: 3/8" "Dolerite", a sample being
shown in Fig. 3.14.
Fine Aggregate: Sand
Aggregate Grading: See Fig. 3.19.
Water/Cement Ratio: 0.55
Aggregate/Cement Ratio: 5.5 : 1
Coarse/Fine Aggregate Ratio: 65% : 35%

Mix Reference B2

Water/Cement Ratio: 0.40
Aggregate/Cement Ratio: 3 : 1
All other details as per mix reference B1

Mix Reference B3

Water/Cement Ratio: 0.35
Aggregate/Cement Ratio: 2.5 : 1
All other details as per mix reference B1

Mix Reference B1

Aggregate Grading : See Fig. 3.21.
Water/Cement Ratio : 0.45
Aggregate/Cement Ratio: 4.5 : 1
Coarse/Fine Aggregate Ratio: 70% : 30%
All other details as per mix reference B1

NOTE: All the above mixes were batched by weight

3.8. TESTING OF SPECIMENS

All specimens were tested at the standard rate of 2000 lbf/sq.ins./minute.

Whereas both faces of the pressurised specimens were adequately smooth for testing requirements, the top face of the "suction only" specimens were not, therefore, after being weighed, these specimens were capped with plaster of paris. The top face of the cylindrical control specimens were made smooth during their manufacture.

The results obtained for Test Series A and B, are 28 day crushing strengths, ie Ordinary Portland cement was used; the results for Test Series B1 are 7 day crushing strengths, ie Rapid Hardening cement was used for these specimens.

A typical failure of a processed specimen is shown in Fig. 3.22.

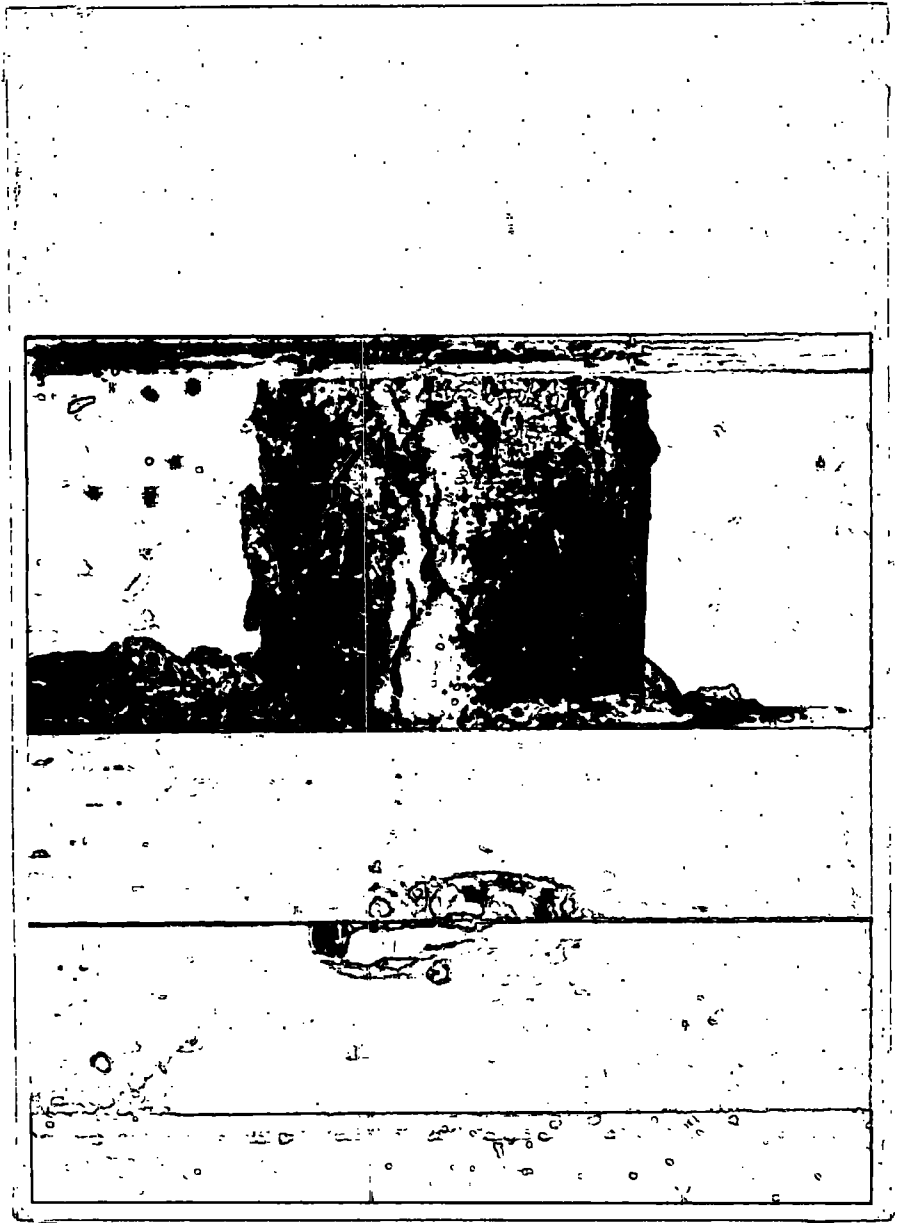

FIG. 3.22. TYPICAL FAILURE OF A PROCESSED SPECIMEN.

CHAPTER 4. RESULTS

TABLE 4.1. RESULTS FOR TEST SERIES "A" (Pressure applied for 20 mins.)

MIX REF.	I. W/C	AVERAGE CONTROL CUBES	AVERAGE CONTROL CYL'S	AVERAGE SUCTION ONLY	INTENSITY OF PRESSURE LBF/SQ. INS.					
					555	F.W/C	1110	F.W/C	3330	F.W/C
A1	0.65	██████	3460	3450	6600	0.42	7500	0.45	7760	0.36
					6550	0.47	7130	0.26	7670	0.36
					6200	0.44	7750	0.49		
					6700	0.42	7670	0.54		
B1	0.55	6830	4632	5350	7340	0.44	7650	0.35	8080	0.32
					6980	0.44	6580	0.33	8000	0.29
					8900	0.46	7700	0.31		
					7670	0.41	7640	0.29		
B2	0.40	8730	7057	-	9640	0.30				
					10280	0.31				
					9200	0.31				
					9820	0.33				
B3	0.35	10420	8412	-	10350	0.29				
					10000	0.23				
					9800	0.24				
					10200	0.26				

NOTATION

I. W/C : INITIAL WATER/CEMENT RATIO

F. W/C : FINAL WATER/CEMENT RATIO

TABLE 4.2. RESULTS FOR TEST SERIES "A" (Pressure applied for 24 hours)

MIX REF.	I. W/C	AVERAGE CONTROL CUBES	AVERAGE CONTROL CYL.'S	AVERAGE SUCTION ONLY	INTENSITY OF PRESSURE LBF/SQ. INS.					
					555	F. W/C	1110	F. W/C	3330	F. W/C
A1	0.65	-	3460	3450	6700	0.40	6650	0.40	7760	0.36
					6870	0.42	7840	0.38	7660	0.35
					6980	0.43	6560	0.40	-	-
					6850	0.44	6770	0.40	-	-
B1	0.55	6830	4632	5350	3920	0.32	7430	0.38	6760	0.32
					7480	0.40	7680	0.39	7350	0.26
					6580	0.35	7280	0.38	-	-
					7060	0.32	7320	-	-	-

TABLE 4.3. RESULTS FOR TEST SERIES "B"

MIX REF	I.W/C.	INTENSITY OF PRESSURE LBF/SQ. INS.					
		555	F.W/C	1110	F.W/C	3330	F.W/C

Pressure applied for 24 hours

A1	0.65	6700	0.40	6650	0.40	7760	0.36
		6870	0.42	7840	0.38	7660	0.35
		6980	0.43	6560	0.40	-	-
		6850	0.44	6770	0.40	-	-
B1	0.55	3920	0.32	7430	0.38	6760	0.32
		7480	0.40	7680	0.39	7350	0.26
		6580	0.35	7280	0.38	-	-
		7060	0.32	7320	-	-	-

Pressure applied for 20 mins.

A1	0.65	6600	0.42	7500	0.45	7760	0.36
		6550	0.47	7130	0.26	7670	0.36
		6200	0.44	7750	0.49	-	-
		6700	0.42	7670	0.54	-	-
B1	0.55	7340	0.44	7650	0.35	8080	0.32
		6980	0.44	6580	0.33	8000	0.29
		8900	0.46	7700	0.31	-	-
		7670	0.41	7640	0.29	-	-

NOTATION:

I.W/C. : INITIAL WATER/CEMENT RATIO

F.W/C. : FINAL WATER/CEMENT RATIO

TABLE 4.4. RESULTS FOR TEST SERIES "B1"

DETAILS:

INTENSITY OF PRESSURE: 1600 LBF/SQ.INS.

MIX REFERENCE: B4

DURATION OF PRESSURE								
20 MINS.			60 MINS.			600 MINS.		
A	B	C	A	B	C	A	B	C
1	6540 4840	9590 8870 7580 8450	4	5830 5640	6860 10120 8610 9040	7	7380 7960	8710 10880 11330 10550
2	6930 5450	8020 7650 8420 8940	5	6430 6280	10540 9040 12080 11320	8	7770 6800	10710 9400 10700 10400
3	5680 5190	8190 8420 7960 9390	6	7440 6670	11540 11490 9100 11940	9	6500 7000	7870 9550 9880 9810

COLUMN NOTATION:

A = SPECIMEN GROUP NUMBER

B = CONTROL SPECIMENS LBF/SQ.INS.

C = PROCESSED SPECIMENS LBF/SQ.INS.

TABLE 4.5. PERCENTAGE STRENGTH INCREASES.

MIX REF.	I.W/C.	SUCTION ONLY	INTENSITY OF PRESSURE LBF/SQ.IN.		
			555	1110	3330

(a) Pressures applied for 20 mins.

A1	0.65	- 3%	90%	117%	124%
		-23%	89%	106%	122%
		12%	79%	124%	-
		4%	94%	122%	-
AVERAGE.....		- 3%	88%	117%	123%
B1	0.55	14%	58%	69%	75%
		9%	51%	42%	73%
		19%	93%	67%	-
		20%	66%	69%	-
AVERAGE.....		16%	67%	62%	74%

(b) Pressures applied for 24 hours.

A1	0.65	-3%	94%	92%	124%
			99%	127%	121%
			102%	90%	-
			99%	96%	-
AVERAGE.....		-3%	98%	101%	122%
B1	0.55	16%	-15%*	60%	46%
			62%	66%	59%
			42%	57%	-
			53%	58%	-
AVERAGE.....		16%	52%	60%	52%

*IGNORED

TABLE 4.6. PERCENTAGE DECREASE IN WATER/CEMENT RATIO

MIX REF.	I.W/C.	SUCTION ONLY	INTENSITY OF PRESSURE LBF/SQ.IN		
			555	1110	3330
A1	0.65	31% 20% 20% 23%	35% 28% 32% 35% 38% 35% 34% 32%	35% 65%* 25% 17% 38% 42% 38% 38%	45% 45% 45% 46%
AVERAGE.....		23%	33%	33%	45%
B1	0.55	15% 13% 25% 20%	20% 20% 16% 25% 42% 27% 36% 42%	36% 40% 44% 47% 30% 30% 30% -	42% 47% 42% 53%
AVERAGE.....		18%	28%	35%	46%
B2	0.40	-	25% 22% 22% 18%	-	-
AVERAGE.....		-	22%	-	-
B3	0.35	-	17% 34% 31% 27%	-	-
AVERAGE.....		-	27%	-	-

* IGNORED

TABLE 4.7. TEST SERIES "B1"

Effect of time of application of pressure
on percentage strength increase

DURATION OF PRESSURE		
20 MINS	60 MINS	600 MINS
46%	53%	35%
38%	69%	41%
56%	56%	38%

SUMMARY

47%	59%	38%
-----	-----	-----

4.2 DISCUSSION OF RESULTS.

All results for processed specimens show an increase in strength over the results obtained for the non-processed specimens, the increase in strength varying from 20% to 123%. However, these strength increases cannot be solely attributed to the application of a hydrostatic pressure since the process also involved the extraction of excess water from the mix, thus lowering the water/cement ratio and increasing the strength of the mix.

Owing to the few results obtained, no definite conclusions can be drawn as to what proportion of the strength increases can be attributed to the lowering of the water content of the mixes. The results for the "suction only" specimens which were carried out on mixes A1 and B1, are inconsistent in that although the water/cement ratio of each was reduced by 23% and 18% respectively, there was a decrease in strength for mix A1 of 3%, and an increase in strength for mix B1 of 16%. An explanation of this is sought in the fact that the maximum size aggregate adopted in mix A1 was 3/16", and upon removal of water from the mix, vibration was no longer an adequate method by which to obtain full compaction, thus resulting in a decrease in strength. This explanation is substantiated by the results obtained for

the processed specimens of the same mix (see Tables 4.1 and 4.2), the decrease in strength being reversed to that of an increase in strength of up to 123%, the application of the pressure being the necessary extra compactive effort required for full compaction.

The results of the test carried out on mix B1, in which the maximum size aggregate was $\frac{3}{8}$ " , show an increase in strength for the "suction only" specimens of 16%, the increase in strength for the processed specimens being as high as 74%. It therefore appears that the majority of the strength increase is due to the application of the pressure and not to the reduction in the water/cement ratio of the mix. This result is deceptive, since the application of the pressure also influences the amount of water extracted from the mix, this being due to its "squeezing" effect on the mix. For mix B1, the reduction in the water/cement ratio for the processed specimens being as high as 46%, whereas the reduction in the water/cement ratio for the "suction only" specimens was only 18%. It could, therefore, be concluded that the difference in strength between the processed and "suction only" specimens is due entirely to the difference in water content removed by each process.

This conclusion is highly improbable, and it would be more accurate to say that the large increases in strength resulting from the process are due to the application of the pressure, the pressure influencing the ultimate crushing strength of the concrete, either directly or indirectly, in the following three ways:-

- (i) By reducing or totally eliminating the microcracks at the aggregate and mortar interfaces, and thus increasing the bond strength.
- (ii) By increasing the amount of water removed from the mix, thus resulting in a lower water/cement ratio than if suction were only applied to the mix.
- (iii) By compressing the concrete to a high degree of compaction, thus decreasing the air voids, and a higher density concrete being obtained.

Effect of Intensity of Pressure.

From the results it can be seen that, generally, as the intensity of pressure is increased, the increase in strength in relation to the control strength also increases. Although not clearly demonstrated by the small range of intensities of pressure investigated, it is apparent that the increments of strength-increase, decrease with each increment of pressure increase, the strength of the

processed specimens will thus reach a limiting value for a given mix.

As previously stated, the application of a pressure also influences the amount of water removed from the mix and as can be seen from the results shown in Table 4.6, it appears that the percentage reduction in the water/cement ratio increased with increase in pressure. This further lowering of the initial water/cement ratio with increase in intensity of pressure could account for the strength increase with increase in pressure, the few results making it impossible for any definite conclusion to be drawn.

Effect of Time of Application of Pressure.

From the results obtained from Test Series B, shown in Tables 4.3 and 4.5, it appears that the percentage increase in strength is greater when the pressure is applied for 20 minutes than when applied for 24 hours, that is, there is a decrease in strength with increase in time of application of pressure. Further results obtained from Test Series B1, and shown in Tables 4.4 and 4.7, show that this is partly correct in that the strength increases with time of pressure application up to a certain point and then decreases. The tests carried out in Test Series B1 involved three durations of time of application of pressure, these being, 20, 60

600 minutes, a summary of the results being given in Table 4.7. From these results, it is noticeable that the best strengths were obtained for the 60 minute pressure application and the worst for the 600 minute pressure application. Owing to the few tests carried out this result is by no means conclusive, but accepting the result as a true representation of the process, an explanation is as follows. After a certain time, in this instance 60 minutes, the initial setting period of the concrete is reached, any application of pressure after this time is acting as a load on the specimen, and thus is detrimental to its ultimate crushing strength.

It should be noted that the application of load to the pistons imposes a "hydrostatic pressure" only as long as the concrete is substantially fluid; once setting is under way the loading tends towards "confined compression". Any future tests must clearly employ a true application of hydrostatic pressure.

4.3. CONCLUSIONS.

1. Substantial increases in the ultimate crushing strength of concrete can be obtained by application of the process.
2. For a given mix, there is a limitation on the increase in strength which can be obtained by the process.
3. The ultimate crushing strength of processed concrete, increases with increase in intensity of pressure, but at a decreasing rate.
4. The effect of time of application of pressure is not fully understood, but it appears that any application of pressure after the initial setting period of the concrete has been reached, is detrimental to its strength.
5. The application of pressure increases the amount of water removed from the concrete, the amount removed increasing with increase in intensity of pressure, but at a decreasing rate.
6. The amount of water which can be removed from the concrete, decreases with decrease of initial water/cement ratio of the concrete.
7. The amount by which the control strength can be increased, decreases as the control strength increases.

PART II. DESIGN AND DEVELOPMENT OF CREEP MACHINE

CHAPTER 5. CREEP OF CONCRETE

5.1 CONCRETE CREEP.

Concrete creep is the nonelastic deformation which continues to increase with time, of concrete subjected to sustained load. Creep is desirable in concrete structures since the favourable distribution of stresses produced by volume changes depends upon the ability of the concrete to adjust itself to stress conditions. The effect of creep is in general to relieve the stresses and thus aid in reducing the tendency towards cracking.

Creep deformations are believed to be due to closure of internal voids, viscous flow of the cement-water paste, crystalline flow in aggregates, and the flow of water out of the cement gel due to external load and drying.

5.2 NEED FOR RESEARCH.

Many of the factors affecting concrete creep and the way they affect are reasonably well known, a brief outline of the most important is given in section 6.1. Consequently a measure of control of creep is available to engineers and Architects, but it must be remembered that while some of the answers are known, a large number of questions still remain unanswered. This is mainly due to the large number of physical variables involved and to the lack of correlated experimental results.

CHAPTER 6. LITERATURE SURVEY

6.1 PHYSICAL FACTORS AFFECTING CONCRETE CREEP.

(1) Humidity During Loaded Period.

The humidity of the atmosphere during the loaded period should affect creep in as much as it influences the expulsion of moisture from the concrete. This is obvious considering that an increase in external humidity reduces the surface evaporation, increases the resistance to capillary flow, and reduces seepage.

(ii) Age at time of loading.

Creep should depend upon the age of the specimen at the time of load application. The further the cement hydration has progressed, the less creep should be obtained.

(iii) Size of Specimen.

It is generally considered that for cylindrical specimens loaded axially creep varies with the diameter but not with the length of the specimen. As the transverse dimensions increase, the corresponding increase in frictional resistance to flow along the capillary channels results in reduction of seepage.

(iv) Mix Proportion.

In considering the effect of mix proportions on creep, the inter-relationships between water content, slump, water/cement ratio, and proportions of constituents must be kept in mind.

Tests by various investigators have shown that creep of concrete decreases as the water/cement ratio and the volume of cement paste decrease. In addition, it has been shown that when a constant water/cement ratio is maintained, creep increases as the slump and cement content increase, or essentially as the amount of cement paste is increased.

(v) Effect of Curing.

Temperature and humidity during the curing period prior to loading have an important effect on creep. The tendency of concrete to creep decreases as cement hydration increases. Consequently, considering hydration alone, water-cured concrete should creep less than air-cured concrete. It must also be recognised that the humidity and temperature conditions during curing may cause shrinkage or swelling which have a strong influence on creep. Under compressive load pre-swelled specimens (resulting from moist curing) creep more than preshrunk specimens (resulting from curing in dry air). The effects of hydration and preswelling are thus opposing factors.

Size effects are important in curing since small specimens respond more rapidly than large specimens to moisture changes. Hence, under similar curing conditions, the degree of hydration and the moisture content of large and small specimens may be different at the time of loading.

(vi) Effect of time of loading.

Investigators have shown that creep increases rapidly during the early stages of the sustained loading period, and that it continues to increase but at a decreasing rate for a long time. In some instances, increases in creep have been reported to 25 years. Approximately one-fourth to one-third of the ultimate creep takes place in the first month of sustained loading, and about one-half to three-fourths of the ultimate creep occurs during the first half-year of sustained loading in concrete sections of moderate size. Richart and Jenson (1938) have measured creep in concrete in compression in relatively short periods, varying from 1 to 30 minutes, under various intensities of stress. Evans (1942) has shown that under instantaneous loading, much more creep occurs in the first 0.01 seconds than in the period from 0.01 seconds to 1.0 minutes.

(vii) Effect of Constituents.

Both composition and fineness of portland cement influence creep characteristics. Concrete made with low-heat cement creeps more than concrete made with normal cement at all ages. Data on the effect of fineness of cement on the creep properties of concrete are scarce, but Davis and Troxwell (1954) state that fineness is probably not as important as composition.

No great amount of work has been done to determine the effects of admixtures on the creep properties of portland cement concrete. Evidence now available indicates that the use of approved air-entraining agents has no appreciable effect on creep. Concretes made with pozzolans generally exhibit greater creep than concretes made without pozzolans. With other things equal, it appears that creep increases as the percentage of cement replacement increases. Where creep is an important factor, proprietary compounds should not be used unless their effects on shrinkage and creep have been previously determined because of their uncertain reactions when used with different cements and in different mixtures.

The size, grading, and mineral character of the aggregate all have an appreciable effect on creep of portland cement concrete. Under comparable conditions, it appears that shrinkage and creep decrease as the maximum size of coarse aggregate increases, and also that both shrinkage and creep decrease when well graded aggregates with low void content are used. The mineral character of the aggregate has an important influence on the creep properties of concrete. Hard, dense aggregates with low absorption and a high modulus of elasticity are desirable when concrete with low shrinkage

and creep are wanted. Under comparable conditions, it appears ~~that~~ increasing amounts of creep may be expected depending upon the aggregate used, in the following order: limestone, quartz, granite, basalt, and sandstone.

6.2 THEORY OF CONCRETE CREEP.

Probably the best known and most acceptable theory of concrete creep is the "Gel Theory" in which it has been suggested that creep of concrete may involve all three of the following types of yielding: (a) crystalline flow (in a crystalline mass, slippage along planes within the crystals; (b) seepage (due to applied pressure, flow of adsorbed water from the cement gel); and (c) viscous flow (movement of particles, as in the flow of asphalt). A portion of the creep may possibly be due to crystalline or viscous flow; neverthe less, it is believed that the major portion is caused by seepage, which would appear to be the most acceptable explanation of creep.

The hydration of portland cement results in the formation of an amorphous or gelatinous mass, ordinarily termed "gel", which serves to connect the aggregate particles. Water may

exist in the concrete mass in three principal forms;

(a) chemically combined water (in chemical combination with the cement), (b) adsorbed water (adsorbed by the cement gel) and (c) free water (water within the microscopic pores or spaces within the gel).

According to Lynam (1934), chemically combined and free water play no direct part in volume changes. Thus except for the effect of hydration, gain or loss of adsorbed water from the gel appears to be the basis of volume changes resulting from ambient moisture variations or from sustained pressure. The gel may be considered as having microscopic pores; with the removal of water the pore spaces collapse and the gel shrinks, while upon the addition of moisture the pore spaces adsorb water and the gel expands. This process is dependent upon frictional resistance to flow of water along the capillary channels which permeate the mass of concrete. Other things being equal, the total frictional resistance is governed by the moisture gradient. The steeper the moisture gradient, the easier the flow of water through the capillary channels. Volume changes of the gel may, on the other hand, be dependent upon seepage caused by applied external pressure. Subjecting the concrete to an external load, the adsorbed water is expelled from the gel.

The rate of expulsion of moisture in this instance is a function of the applied load and of the friction in the capillary channels. The greater the applied load, the steeper the pressure gradient with consequent increase in rate of moisture expulsion. By the foregoing hypothesis shrinkage or swelling due to loss or gain of moisture and creep due to seepage are interrelated phenomena.

CHAPTER 7. INVESTIGATIONS CARRIED OUT

7.1. Design Approach.

The main consideration in the design of the creep machine was that it should be flexible in as much that an extensive range of stresses could be applied to several specimens simultaneously for an indefinite period of time.

The approach of the design, manufacture, and subsequent development of the creep machine, was basically that of phasing the work into three stages, these being:-

- (i) Design of creep machine frame.
- (ii) Design of apparatus for alignment of specimens.
- (iii) Design of creep measuring device.

Owing to the limited time available, the completion and subsequent preliminary testing of the creep machine was not realised, the actual work which was carried out on each design stage is described in the relevant sections which follow.

7.2. Design of creep machine frame.

The frame was designed to apply a maximum load of 10 tonf. to the specimens, and in order to achieve a high stress level the specimens were made as small as possible, the actual

specimens being those which were developed under Part I of the thesis, i.e. 2 inches diameter x approximately 2 inches long. The choice of small specimens also meant that a greater number could be tested simultaneously in the same machine than if larger specimens had been used.

Since high stress levels were required to be maintained constant over relatively long periods of time, the choice of method of application of the load was that of a mechanical device rather than a hydraulic one, the mechanical device being that of a system of lever arms.

The working principle of the creep machine is shown in Fig. 7.1, the actual completed frame being shown in Fig. 7.2. All the pivot points incorporate rolling-contact bearings. The loading arm of the frame incorporates a ball seating through which the load can be applied to the specimens, the choice of the lower seating being that of a spherical type of same diameter as the specimens.

In order to achieve uniform (axial) loading of the specimens, alignment of upper and lower seating would have to be ensured. This was attempted by placing a 2" diameter brass rod, to which was attached two sets of strain gauges, between the two seatings. Each set of strain gauges, one set at each end of the rod, consisted of 4 gauges situated



circumferentially around the rod at 90 degree intervals, see Fig. 7.3. Varying loads were then applied to the rod and each strain gauge reading was noted. For axial loading of the brass rod, and thus alignment of the seatings, the strain at each circumferential point on the rod should be the same for each corresponding intensity of load. This condition was not fulfilled, since, although the majority of the strain readings fell within an acceptable limit, the discrepancy between the strain readings at point 'X' and point 'Y' was unacceptable. (See Table 7.1. and Fig. 7.4 for a typical set of strain readings). The possibility of the strain gauges at these two points being faulty was eliminated, since, although the rod was turned through 90 degrees and 270 degrees, the same result was obtained.

On inspection of the strain readings at points 'X' and 'Y', it can be seen that the readings at 'X' are always higher than the readings at 'Y'. This result only applied when the brass rod was positioned so that all strain readings were approximately the same for a load of 20 lbf. and the load was increased to 100 lbf. Although no results are shown it was found that if the brass rod was positioned so that all the strain readings were the same for a load of 100 lbf.,

and the load was decreased to 20 lbf., the readings at 'Y' were always higher than the readings at 'X'. From this it was deduced that the cause of the discrepancy at these two points was the manner in which the load was applied to the brass rod. As can be seen from Fig. 7.5., the loading arm moves in a radial path as the load is increased or decreased, and since the ball seating soon becomes ineffective as the load is increased, the axis of loading varies (only in the same axis as the movement of the loading arm) as the load is increased or decreased. The movement of the axis being towards point 'X' as the load increases, thus explaining the discrepancy between the strain readings obtained at 'X' and 'Y'. The corresponding strain gauges at the other end of the rod were situated so near the point of loading that the radial movement of the loading arm cause no recognisable discrepancy in their readings.

The simplest solution to this problem was adopted by making the base-plate for the lower seating moveable in the direction of the loading arm so that alignment could be carried out each time the load was altered.

FIG.7.1. WORKING PRINCIPLE OF CREEP MACHINE

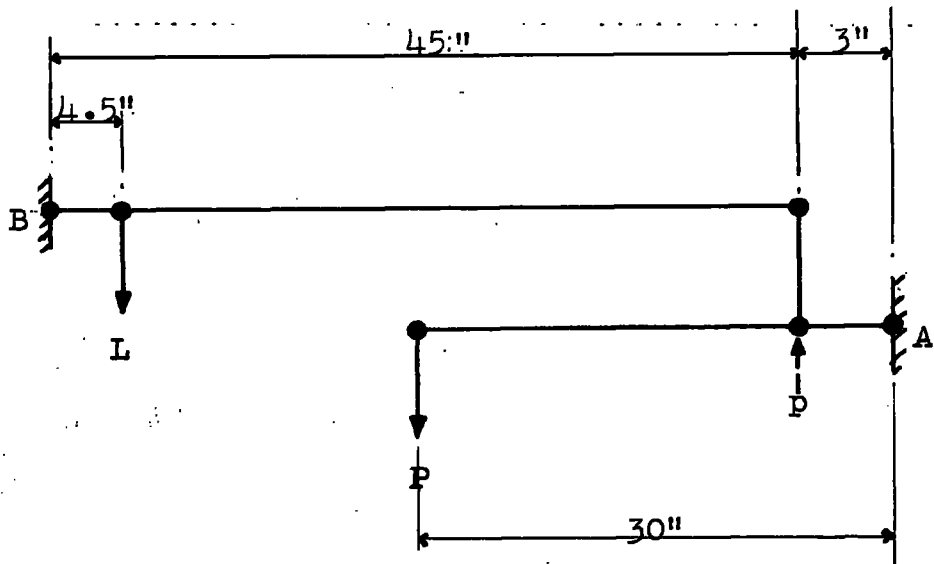

DIAGRAMMATIC REPRESENTATION OF LEVER ARM SYSTEM

CALCULATIONS:

Let applied load= P

Let resultant load on specimen= L

From above, taking moments about A

$$p \times 3 = P \times 30$$

$$\therefore p = 10P \dots\dots\dots(I)$$

Also, taking moments about B

$$4.5L = 45p$$

$$\therefore L = 10p \dots\dots\dots(II)$$

But from (I) above, $p = 10P$, therefore substituting into equation (II),

$$\underline{L = 100P}$$

This is the theoretical lever arm ratio, and it is suggested that the actual ratio of the completed creep machine be deduced experimentally by the use of a load cell. 104.

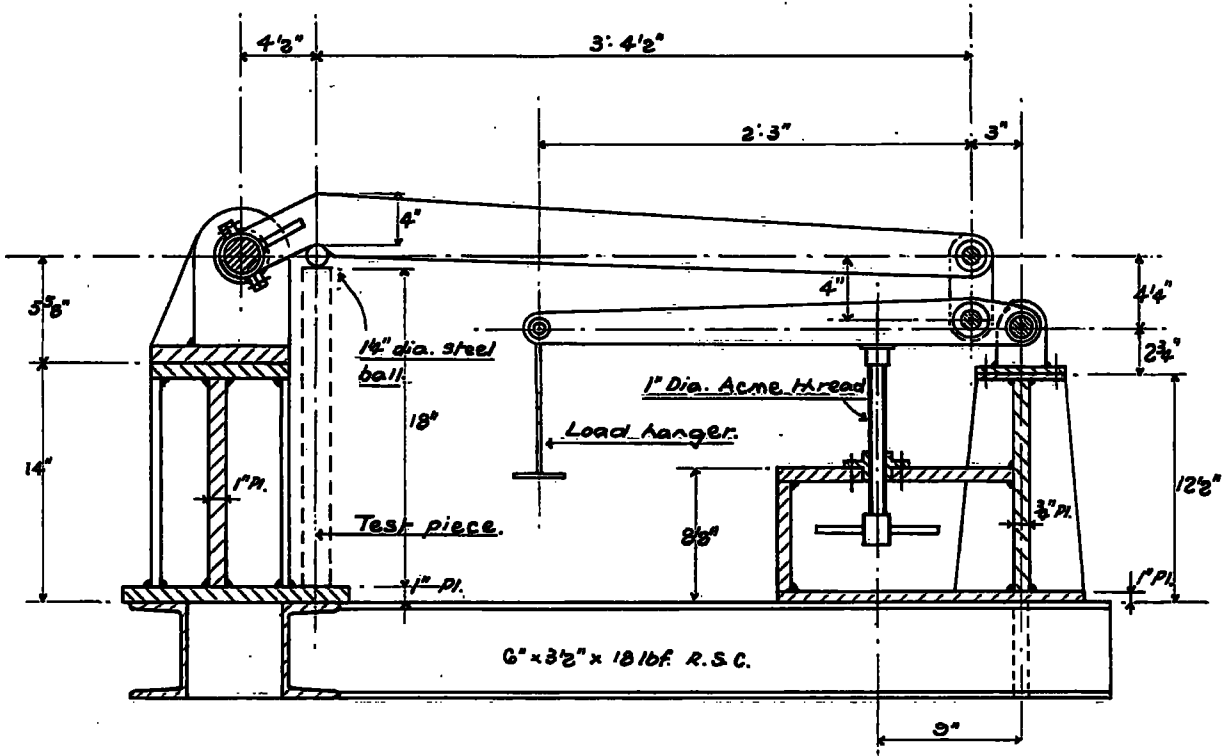

Typical Section Through Creep Machine Frame

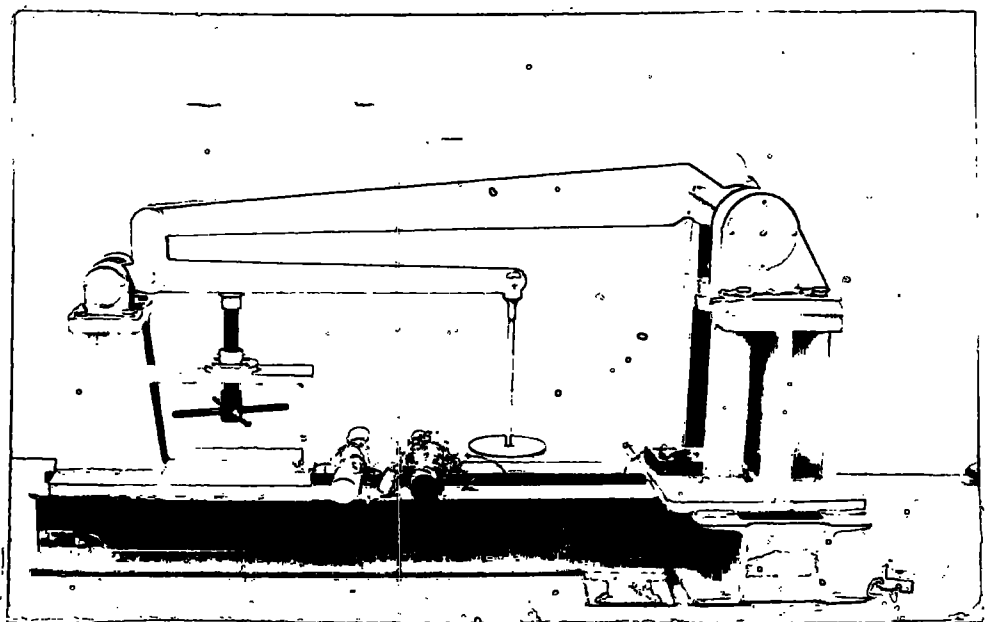
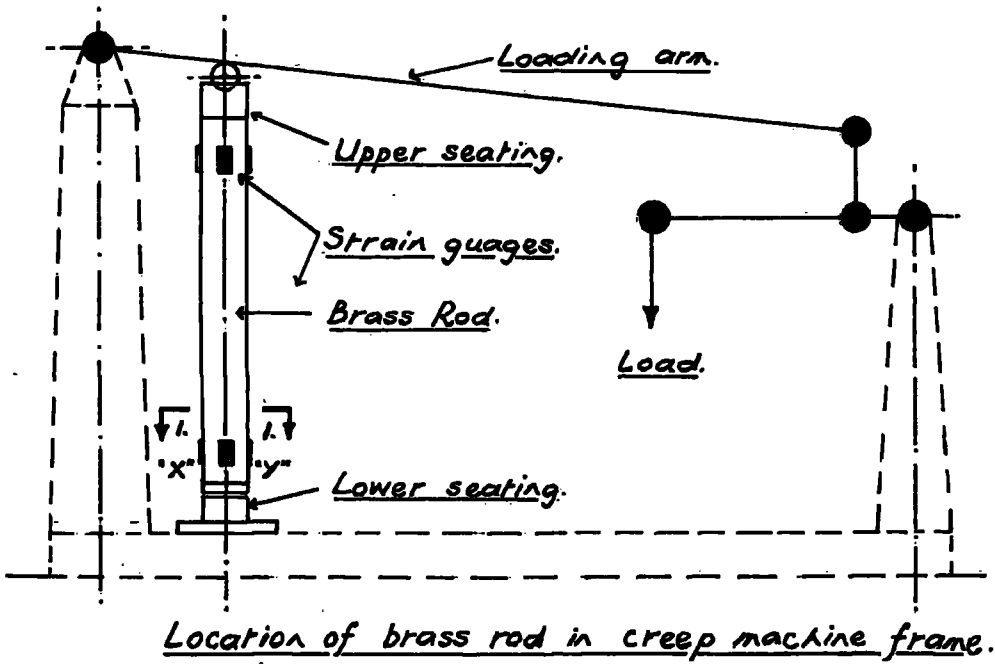
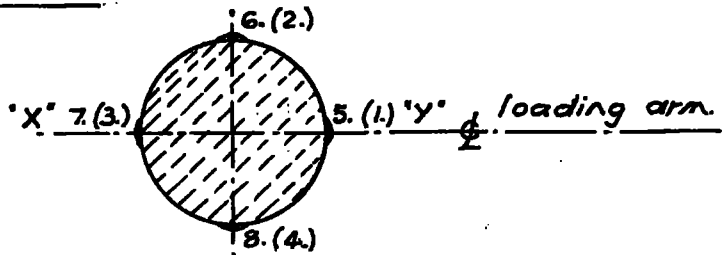

FIG. 7.2. DETAILS OF COMPLETED CREEP MACHINE FRAME



Enlarged Plans on "1.1." :-

Position "A"



Position "B"

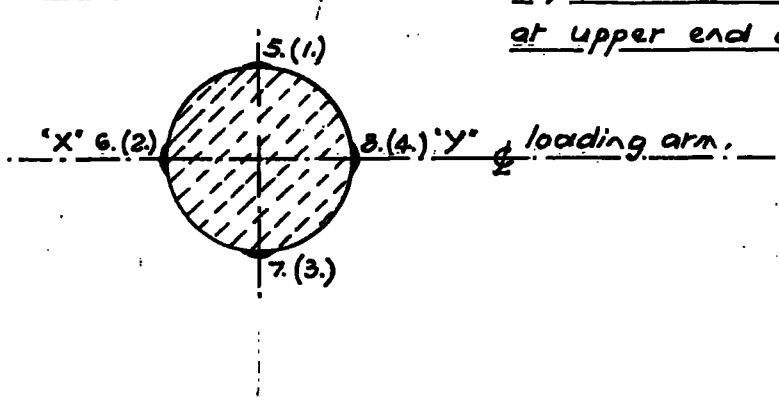

Numbers in parenthesis refer to strain gauges at upper end of rod.

Fig. 7.3. Location of strain gauges.
(For strain readings see Table 7.1)

TABLE 7.1. ALIGNMENT OF UPPER AND LOWER SEATINGS

STRAIN READINGS FOR TWO POSITIONS OF
BRASS ROD

LOAD LB.F.	STRAIN READINGS (X 10 ⁻⁶)							
	1	2	3	4	5	6	7	8

POSITION "A"

0	0	0	0	0	0	0	0	0
20	78	81	80	83	78	79	83	79
40	124	121	115	127	113	128	128	118
60	165	161	150	162	148	169	175	158
80	206	201	190	208	178	209	224	199
100	244	243	232	247	211	249	267	236
					"Y"		"X"	

POSITION "B"

0	0	0	0	0	0	0	0	0
20	74	63	71	81	73	78	70	77
40	116	110	109	120	113	119	115	112
60	158	150	147	168	149	162	144	148
80	199	191	188	204	193	215	196	182
100	240	231	228	248	232	265	237	212
						"X"		"Y"

NOTE: FOR POSITIONS OF BRASS ROD AND LOCATION

OF STRAIN GUAGES SEE FIG. 7.3.

FOR LOAD/STRAIN GRAPHS SEE FIG. 7.4.

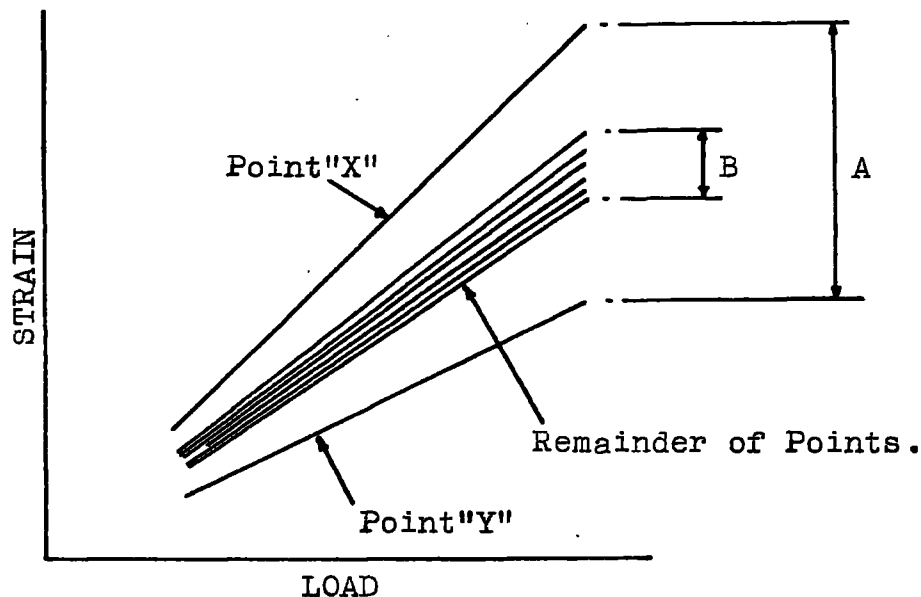

FOR POSITION "A" OF BRASS ROD

Max. variation between strain readings at points "X" and "Y" = 21% (Unacceptable)

Max. variation between strain readings at remainder of points = 7% (Acceptable)

FOR POSITION "B" OF BRASS ROD

Max. variation between strain readings at points "X" and "Y" = 20% (Unacceptable)

Max. variation between strain readings at remainder of points = 8% (Acceptable)

Note: For actual strain readings see Table 7.1.

For positions of brass rod and location of strain gauges see Fig. 7.3.

FIG. 7.4. LOAD/STRAIN GRAPHS FOR RESULTS SHOWN
IN TABLE 7.1.

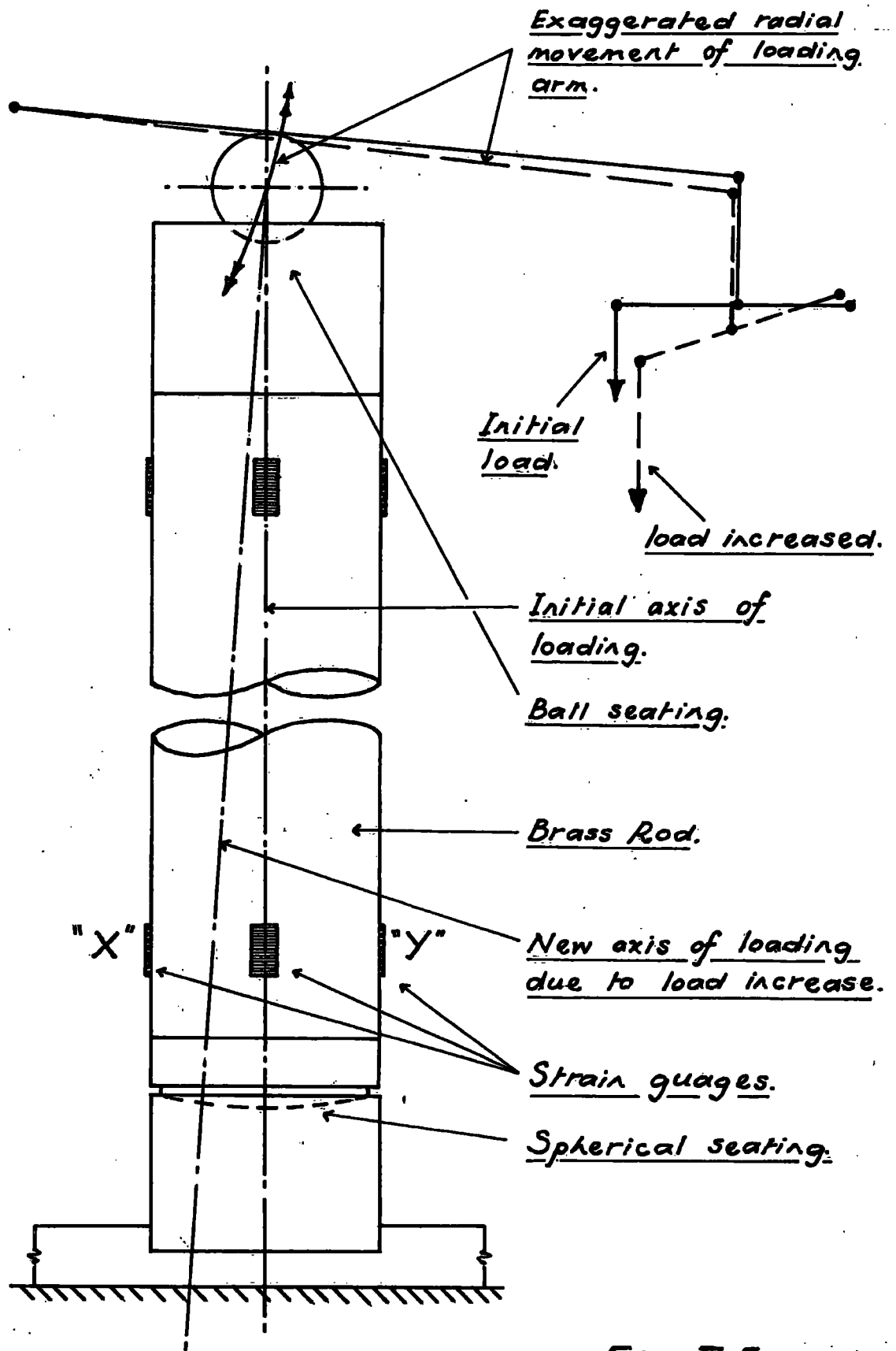

Fig. 7.5.

7.3. DESIGN OF APPARATUS FOR ALIGNMENT OF SPECIMENS.

Since several specimens were to be loaded simultaneously in tandem fashion, apparatus for alignment of the specimens had to be designed if uniform (axial) loading of the specimens was to be ensured. The design and development of the creep machine frame placed certain requirements and limitations on the design of the alignment apparatus, these were as follows:

- (i) Apparatus to be removeable from creep machine frame.
- (ii) Lower seating to be moveable in direction of loading arm.
- (iii) Apparatus to incorporate strain guages in order that alignment of upper and lower seatings could be carried out whenever the load was altered.
- (iv) Height of lower seating to be adjustable so as to facilitate varying lengths of specimens.
- (v) Maximum distance between upper seating and creep-machine base-plate : $18\frac{3}{4}$ ".

The apparatus is shown in Fig. 7.6., and consists of 1" deep by $4\frac{1}{2}$ " diameter discs which act as specimen seperators and will also serve as creep measuring points. The specimens are located into these discs by means of a cylindrical recess of same diameter as specimen plus tolerance. The

discs, and thus the specimens, are aligned by means of three $\frac{5}{8}$ " diameter rods radially spaced at 120 degrees on a pitch circle diameter of $3\frac{1}{4}$ ". To achieve accuracy of alignment, the depth of the recesses for the specimens, and the diameter of the rods, were made as large as possible; the pitch circle diameter of the rods being made as small as possible.

The recessing of the specimens should not affect their creep characteristics since the tolerance fit needed for assembly would be greater than the lateral displacement of the specimens under creep conditions.

It was unfortunate that during the manufacture of the apparatus the allocated research period terminated, and thus no preliminary testing of the apparatus could be carried out.

7.4. DESIGN OF CREEP MEASURING DEVICE.

Due to the limited time available only preliminary research work into the problem of creep measurement was able to be carried out.

From the preliminary investigations carried out, it was thought that the best solution to the problem was that of a portable measuring device which could be placed between specific measuring points located on each of the specimen separator discs which form part of the apparatus for alignment of the specimens. It is suggested that a minimum of three measuring points be radially spaced at 120° intervals around each specimen.

The above proposals would thus enable a minimum of three creep measurements to be taken for each specimen at any time of loading.

The working principle of the measuring device would either be (a) that of an air gauging device, or (b) a transducer system.

Although both systems would give a high degree of sensitivity, the wide range of measurement which is required in the creep testing of concrete would be best obtained if a transducer system was adopted.

REFERENCES:

- ABRAMS, D., "Water-Cement Ratio as a Basis of Concrete Quality". A.C.I. Journal, Vol.23, 1927.
- ALEXANDER, K.M., "Factors Controlling the Strength and Shrinkage of Concrete". Constructional Review. Nov.1960. Vol.33, No.11.
- BAKER, A.L.L., "An Analysis of Deformation and Failure Characteristics of Concrete". Magazine of Concrete Research. Vol.11, No.33, Nov.1959.
- BLOEM, D.L. and GAYNOR. R.D., "Effect of Aggregate Properties on Strength of Concrete". A.C.I. Journal, Oct.1963, Proc.V.60, pp.1429-1454
- DAVIS, R.E. and TROXWELL, G.E., "Properties of Concrete and their Influence on Prestress Design". A.C.I. Journal, Jan.1954, Proc.V.50, pp.381-392.
- EVANS, R.H., "Some New Facts Concerning Creep in Concrete". Concrete and Constuctional Engineering(London). V.37, 1942, pp.429.
- GARNETT, J.B., "The Effect of Vacuum Processing on Some Properties of Concrete". Cement and Concrete Association, Technical Report TRA/326 Oct.1959.

GYENGO,T., "Effect of Type of Test Specimen and Gradation of Aggregate on Compressive Strength of Concrete" A.C.I. Journal, Jan.-Feb.1938, Proc.V.34, pp.269-282.

HAWKES,J.M., "The Effect of Mix-Proportion on Vacuum Concrete." Civil Engineering and Public Works Review. Vol.56, No.664, Nov.1961 and Vol.56, No.665, Dec.1961.

HSU,T.T.C., SLATE,F.O., STURMAN,G.M. and WINTER,G., "Microcracking of Plain Concrete and the Shape of the Stress-Strain Curve." A.C.I. Journal, Feb.1963, Proc.V.60, No.2, pp.209-223.

JENSON,R.S. and RICHART,F.E., "Short-Time Creep Tests of Concrete in Compression." Proceedings ASTM, V.38, PartII, 1938. p.410.

LYNAM,C.G., "Growth and Movement in Portland Cement Concrete." Oxford University Press, 1934.

SIGVALDASON,O.T., "The Influence of Testing Machine Characteristics upon the Cube and Cylinder Strength of Concrete." Magazine of Concrete Research, Vol.18, No.57, Dec.1966.

WALKER,S., BLOEM,D.L. and GAYNOR,R.D., "Relationships of Concrete Strength to Maximum Size of Aggregate." Highway Research Board, Proceedings of the thirty-eighth annual meeting, Jan.5-9, 1959.

WALKER,S. and BLOEM,D.L., "Effects of Aggregate Size on Properties of Concrete." A.C.I. Journal, Sept.1960, Proc.V.57, pp.283-298.



Fig. 7.6. General View H'ro' Alignment Apparatus. (Scale: $\frac{1}{2}$ fullsize)

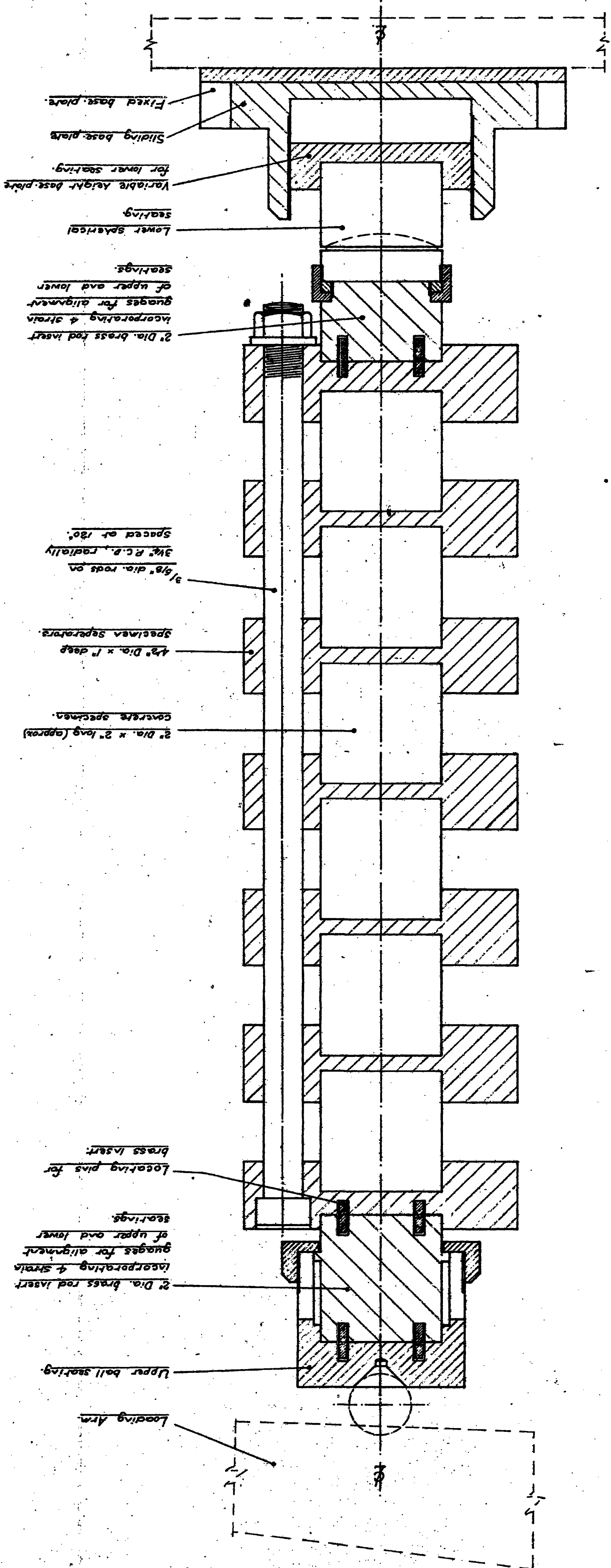

FIG. 7.6. DETAILS OF ALIGNMENT APPARATUS.

7.4. DESIGN OF CREEP MEASURING DEVICE.

Due to the limited time available only preliminary research work into the problem of creep measurement was able to be carried out.

From the preliminary investigations carried out, it was thought that the best solution to the problem was that of a portable measuring device which could be placed between specific measuring points located on each of the specimen separator discs which form part of the apparatus for alignment of the specimens. It is suggested that a minimum of three measuring points be radially spaced at 120° intervals around each specimen.

The above proposals would thus enable a minimum of three creep measurements to be taken for each specimen at any time of loading.

The working principle of the measuring device would either be (a) that of an air gauging device, or (b) a transducer system.

Although both systems would give a high degree of sensitivity, the wide range of measurement which is required in the creep testing of concrete would be best obtained if a transducer system was adopted.

REFERENCES:

- ABRAMS, D., "Water-Cement Ratio as a Basis of Concrete Quality". A.C.I. Journal, Vol.23, 1927.
- ALEXANDER, K.M., "Factors Controlling the Strength and Shrinkage of Concrete". Constructional Review. Nov.1960. Vol.33, No.11.
- BAKER, A.L.L., "An Analysis of Deformation and Failure Characteristics of Concrete". Magazine of Concrete Research. Vol.11, No.33, Nov.1959.
- BLOEM, D.L. and GAYNOR. R.D., "Effect of Aggregate Properties on Strength of Concrete". A.C.I. Journal, Oct.1963, Proc.V.60, pp.1429-1454
- DAVIS, R.E. and TROXWELL, G.E., "Properties of Concrete and their Influence on Prestress Design". A.C.I. Journal, Jan.1954, Proc.V.50, pp.381-392.
- EVANS, R.H., "Some New Facts Concerning Creep in Concrete". Concrete and Constuctional Engineering(London). V.37, 1942, pp.429.
- GARNETT, J.B., "The Effect of Vacuum Processing on Some Properties of Concrete". Cement and Concrete Association, Technical Report TRA/326 Oct.1959.

GYENGO,T., "Effect of Type of Test Specimen and Gradation of Aggregate on Compressive Strength of Concrete" A.C.I. Journal, Jan.-Feb.1938, Proc.V.34, pp.269-282.

HAWKES,J.M., "The Effect of Mix-Proportion on Vacuum Concrete." Civil Engineering and Public Works Review. Vol.56, No.664, Nov.1961 and Vol.56, No.665, Dec.1961.

HSU,T.T.C., SLATE,F.O., STURMAN,G.M. and WINTER,G., "Microcracking of Plain Concrete and the Shape of the Stress-Strain Curve." A.C.I. Journal, Feb.1963, Proc.V.60, No.2, pp.209-223.

JENSON,R.S. and RICHART,F.E., "Short-Time Creep Tests of Concrete in Compression." Proceedings ASTM, V.38, PartII, 1938. p.410.

LYNAM,C.G., "Growth and Movement in Portland Cement Concrete." Oxford University Press,1934.

SIGVALDASON,O.T., "The Influence of Testing Machine Characteristics upon the Cube and Cylinder Strength of Concrete." Magazine of Concrete Research, Vol.18, No.57, Dec.1966.

WALKER,S., BLOEM,D.L. and GAYNOR,R.D., "Relationships of Concrete Strength to Maximum Size of Aggregate." Highway Research Board, Proceedings of the thirty-eighth annual meeting, Jan.5-9, 1959.

WALKER,S. and BLOEM,D.L., "Effects of Aggregate Size on Properties of Concrete." A.C.I. Journal, Sept.1960, Proc.V.57, pp.283-298.

