



Durham E-Theses

Some experiments in man-machine interaction relevant to computer assisted learning

Yeates, H.

How to cite:

Yeates, H. (1981) *Some experiments in man-machine interaction relevant to computer assisted learning*, Durham theses, Durham University. Available at Durham E-Theses Online:
<http://etheses.dur.ac.uk/10195/>

Use policy

The full-text may be used and/or reproduced, and given to third parties in any format or medium, without prior permission or charge, for personal research or study, educational, or not-for-profit purposes provided that:

- a full bibliographic reference is made to the original source
- a [link](#) is made to the metadata record in Durham E-Theses
- the full-text is not changed in any way

The full-text must not be sold in any format or medium without the formal permission of the copyright holders.

Please consult the [full Durham E-Theses policy](#) for further details.

**SOME EXPERIMENTS IN MAN-MACHINE INTERACTION
RELEVANT TO COMPUTER ASSISTED LEARNING**

A Thesis submitted for the degree of
Master of Science
in the University of Durham

VOLUME I

The copyright of this thesis rests with the author.
No quotation from it should be published without
his prior written consent and information derived
from it should be acknowledged.

April 1981

H. Yeates, ACMA, MBCS



CONTENTS

		<u>Page</u>
Abstract		i
Preface		ii
Acknowledgements		iv
Chapter 1	Theory of Communication	1
Chapter 2	Use of Conventional Media	19
Chapter 3	The Use of the Computer as an Instructional Tool	32
Chapter 4	Development of an Integrated Approach to CAL	52
Chapter 5	Industrial and Commercial Applications of CAL	77
Chapter 6	Micro Multi-Media CAL Experiments	105
Chapter 7	Current Trends and Future Prospects for Instructional Uses of the Computer	168

**SOME EXPERIMENTS IN MAN-MACHINE INTERACTION
RELEVANT TO COMPUTER ASSISTED LEARNING**

ABSTRACT

Various techniques for the communication of instructional material are outlined. Some experiments relevant to the design of multi-media computer assisted learning systems are then described.

PREFACE

This thesis is in two volumes: the first describes the theory, evidence and techniques that exist to support the use of multi-media communication methods; the second is a compendium of the resources used to construct the experimental computer assisted learning package described in this study. Volume 2 contains a slidefile, audio tape script, program listing, guidebook and details of the pre-test and post-test questions formulated for system evaluation purposes.

This volume describes the background research that was undertaken and the experiments that have been conducted. It is divided into seven chapters whose contents are briefly outlined below.

Chapter 1 provides an introduction, describes various theories of communication and outlines some of the problems which can arise when people communicate with each other. The case for multi-media communication is described.

Chapter 2 examines the use of conventional media such as print, tapeslides, tape/microfiche and video, and discusses their advantages and disadvantages.

Chapter 3 describes the use of the computer as an instructional tool. It reviews the historical background to CAL, the various modes of instruction that have been developed and the influence of micro-electronics.

Chapter 4 reviews the development of the integrated approach to instruction and describes the use of advanced multi-media learning systems such as PLATO (University of Illinois), TICCIT (MITRE Corporation, University of Texas and Brigham Young University) and CYCLOPS (Open University) in the fields of education and training.

Chapter 5 discusses training problems and presents some descriptions of CAL projects that illustrate the approaches currently being used to solve these problems. Some commercial, industrial and military uses of computer based training are described.

Chapter 6 covers the practical aspects of the current research and describes the design and production of a microcomputer based multi-media learning system.

Chapter 7 outlines further research contemplated and the peripheral devices that may in the future be used to produce a low cost CAL system that exploits the latest technological advances. It also reviews the current trends in technology and the future prospects for instructional uses of the computer.

Various sources of information were used in compiling the material presented in this thesis. Particularly valuable were the three seminars on computer based training in industry and commerce organised by Mills & Allen Communications Limited for the Training Division of the Manpower Services Commission.

Visits to various organisations were conducted in order to discuss computer based training. Amongst the installations that were visited are included the BARCLAYCARD Headquarters at Northampton and the Midland Bank Computer Operations Training Branch at Sheffield. In addition, time spent at the Independent Broadcasting Authority research establishment at Crawley Court (near Winchester) provided considerable opportunity for discussion of CAL developments in the area of teletext systems and telesoftware.

Some 25 books and 54 reports and articles have been read and analysed during the period of study. References to these are included at the end of those chapters that cite them.

ACKNOWLEDGEMENTS

I wish to acknowledge the assistance of many people who have made this thesis possible. In particular the following have given invaluable help and advice.

Mr. J.W. Gritton, Director of the Northern Regional Management Centre, whose guidance and support when applying for the course is greatly appreciated.

Mr. J.N. Slater, Engineering Information Department of the Independent Broadcasting Authority, whose help with specialist knowledge and advice on teletext systems was of considerable value to the author.

Mr. S. Turner and Mr. G.W.G. Winkfield of Philips Industries Research Department for information on developments in home microcomputing and videodisks respectively.

Mr. David Wright, Training Manager of Mills & Allen Communications Ltd., Mr. A.F. Cook, Training Manager, Barclaycard, and Dr. J.A. Wilson, Specialist Adviser to the Midland Bank Computer Training Branch, for information on developments in computer based training.

Dr. Douglas M. Towne of the University of Southern California for details of his work on CAL with the U.S. Navy.

Mr. Richard Fothergill of Newcastle upon Tyne Polytechnic for technical assistance with the production of audiotapes and for participating in the evaluation of the CAL experiments.

Dr. G.N.C. Kenny, Department of Anaesthesia, Royal Infirmary, Glasgow, for invaluable technical information on the microcomputer/slide projector interface.

I am also very grateful to Mrs. Pat Croft, my thesis typist, for her patience and skill in the application of word processing equipment for the production of this work.

Finally, and most of all, I am indebted to Dr. Philip G. Barker, my study supervisor. His enthusiasm for the subject continually motivated and supported the author throughout the study. Without his guidance, advice and considerable help with programming this work would not have been possible.

To all of the above and many others who have given their time to help me - my grateful thanks.

CHAPTER 1

THEORY OF COMMUNICATION

- 1.1 Introduction
- 1.2 What is Communication?
- 1.3 Some Barriers to Communication
 - 1.31 Limitation of the Receiver's Capacity
 - 1.32 Distraction (Noise)
 - 1.33 Unstated Assumptions
 - 1.34 Incompatibility of Schemas
 - 1.35 Intrusion of Unconscious or Partly Conscious Mechanisms
 - 1.36 Confused Presentation
 - 1.37 Absence of Communication Facilities
- 1.4 The Importance of Vision in Communication
 - 1.41 Introduction
 - 1.42 Reasons for Using Pictures
- 1.5 Retention of Visual Information
- 1.6 Uses of Media for Learning
 - 1.61 Classification of Types of Information Carrier
 - 1.62 Types of Communication Channel
 - 1.63 The Role of the Computer as an Audio-Visual Resource
 - 1.64 The Need for Integrated Multi-Media Communication
- 1.7 Conclusion

CHAPTER 1

THEORY OF COMMUNICATION

1.1 INTRODUCTION

Education is concerned with 'communication', that is with the transmission of information from one species (an information source or donor) via a suitable communication channel, to another species (an information receiver or acceptor).

In this chapter the ambiguity of the word 'communication' is examined and its meaning established in the context of this thesis. The importance of vision in the communication process is discussed and the concept of a data base using multi-media communication is described.

1.2 WHAT IS COMMUNICATION?

The word 'communication' is one that has a multitude of meanings depending upon the exact context in which it is used. Consequently, many 'subject oriented' definitions arise from its use within areas as diverse as science, technology, education, management, psychology, sociology, linguistics, information theory, mass media studies and so on. Indeed, Williams and Pearce (1978, Ref. 1) conclude that the term communication is so broadly applied that it verges on meaninglessness. This problem of terminology has been described by Maude (1974, Ref. 2) who has suggested that many of the barriers to communication between human groups have arisen as a result of the ambiguity associated with the term itself.

The opposite point of view, that a fuzzy definition of 'communication' can be advantageous, has been presented by Dance (1970, Ref. 3) who has proposed that some degree of caution should be exercised when attempting to secure a single, rigid,



exclusive definition of the term. This is important since technological advances and more refined research continually necessitate the meaning of the term to be modified in the light of new knowledge.

Bearing in mind these two extreme views, it is important to atune the meaning of the term as used in this thesis with those others that exist and thus establish a common frame of reference.

An analysis of the different meanings of the term communication enables a fuzzy concept to be constructed: generally, the idea of 'transfer of material' is common to most of the definitions that exist. Consequently, communication can sometimes refer to 'what is transferred' (for example, historical facts, sales figures, electrical impulses, etc.) while on other occasions it refers to the 'means of transfer' (for example, blackboard, book, slide, electrical cable, optical fibre, etc.). Frequently the term is used to encompass both of these facets - what is conveyed and the means of conveyance.

For the present purpose, communication will be defined as a process for the transmission of information by the use of symbols, words and pictures of various forms. It is thus a mechanism by means of which a thought, idea or concept is transferred from one entity to another.

Communication, in general, serves a number of purposes:

- (a) to act as a stimulus between a source and a recipient of a message
- (b) to act as a carrier of information
- (c) to create interactions and relationships
- (d) to influence the behaviour of some entity

It is important to understand the purposes of communication in order that suitable techniques and methods may be employed to aid the transfer of material between those involved in the communication process.

1.3 SOME BARRIERS TO COMMUNICATION

Whenever people communicate with each other problems often arise as a result of a variety of 'barriers' that may be built up between them. Consequently, recognition of common barriers to good communication is important. Parry (Ref. 4) lists seven fundamental sources of problems.

1. Limitation of the receiver's capacity
2. Distraction (noise)
3. Unstated assumptions
4. Incompatibility of schemas
5. Intrusion of unconscious or partly conscious mechanisms
6. Confused presentation
7. Absence of communication facilities

These barriers are now considered in turn and their effects on learning discussed.

1.31 **Limitation of the receiver's capacity**

The ability of the human memory to discriminate and to retain information is limited. Experimental evidence (Miller, 1970, Ref. 5) suggests that memory tends to be limited to about seven bits of information, that is, seven headings or key words. Parry refers to short term and long term memory. The short term memory is thought to last a few seconds and long term memory over a much longer period of time. In order to extend the memory span the mind develops patterns of ideas. Some find mnemonics a useful aid to memory, while others associate ideas with pictures. But if ideas are presented in such a way that the pattern developed is confusing, or when too much information is presented, then the information is rejected because it is beyond the receiver's capacity.

Designers of educational materials must take this communication barrier into account when developing learning packages.

1.32 **Distraction (Noise)**

In the communication process any disruption in the message that passes between the sender and the receiver is called 'Noise'. Distraction is probably the most common form of noise. The phenomenon of distraction is familiar in many contexts, too numerous to list here. Noise in the context of a message creation process is particularly important. If a message is ill-prepared it may contain substantial sources of noise. Whether the message is spoken, written or possesses some graphic or non-verbal form, it cannot be more effective than the quality of its preparation. For example, a teacher's illegible writing on a blackboard or overhead projector or the glare from a screen or visual display unit are competing stimuli and are, technically, noise. The atmosphere in a room, uncomfortable seating or an excess of unfamiliar language or jargon also constitute noise.

1.33 **Unstated Assumptions**

A barrier to communication can be built up because the communicator makes assumptions about the receiver's basic knowledge.

For example, the sender of the message may have preconceived ideas of the receiver's knowledge of a particular subject. If the receiver has less knowledge than the sender believes, communication could fail because the sender uses unfamiliar words. The reverse situation is equally likely. Here the receiver of a message has greater familiarity with the topic than the sender gives him credit for.

1.34 **Incompatibility of Schemas**

A schema is a plan or pedagogical strategy for the presentation of a collection of information or teaching material. A teacher plans a lesson by considering timing, arrangement of information, the words used, the method of presentation and the layout of the illustrations.

One problem in communication lies in the interpretation of the

information received. For communication to occur interpretation is essential, but if the experience and background of the receiver are very different from that of the sender (for example, a foreign student with a very different cultural background attending a course based on Western culture), the interpretation can be very different from that intended. There is an incompatibility of schemas.

The overlap of schemas between the teacher and the learner is crucial to learning for the schemas do not only relate to knowledge but also to feelings and reactions.

1.35 Intrusion of Unconscious or Partly Conscious Mechanisms

The unconscious or partly conscious mechanisms include feelings and reactions to a message. Communication can be inhibited or prevented by feelings such as love, worry or fear. Reactions to a message can be influenced by fatigue or stress or to the attitudes, experiences and beliefs of the receiver.

For example, a listener may take a dislike to the personal characteristics and/or attributes of the sender. This will influence his reception of the message. If the communication is prevented by the above mechanisms, learning is affected.

1.36 Confused Presentation

Teachers and instructors are very versatile teaching resources. This is because they can quickly adapt their teaching strategies to meet all their students' changing needs. However they can experience problems in the matter of presentation of information. A teacher has a very limited means of presenting information. This can cause difficulty in explaining visual phenomena and describing complex dynamic systems. To overcome these shortcomings he makes use of other media to aid him. A teacher's speed of calculation is also limited. His explication of real world systems may have to be calculated in advance and this renders him less flexible.

1.37 **Absence of Communication Facilities**

The channel is the route of a message over any of several media. These include the human sensory means of sight and sound and also electronic means of sending messages. If, for any reason, a communication channel is obstructed, there can be no message transfer. For example, a teacher who talks for the whole of a tutorial period without giving his students an opportunity to ask questions is effectively obstructing a channel. Failure of the student, or the teacher, to listen is a further example of this situation.

1.4 **THE IMPORTANCE OF VISION IN COMMUNICATION**

1.41 **Introduction**

Developments in photography, television and in a wide range of photographic techniques and projection devices have created a situation where, willingly or not, people are constantly subjected to the potential influence of pictorial images.

Every medium has its own properties, and good communication depends upon these properties being exploited in a given situation. The importance of pictures in the communication process is discussed in this section.

1.42 **Reasons for using Pictures**

Often pictures are shown in an attempt to substitute for real life experiences. The communication of such experiences would be difficult, and sometimes impossible, by means of speech and gestures alone. In a teaching situation, therefore, the picture is often used as a substitute for direct personal experience or the 'real thing'.

There are occasions when reality can be brought into the classroom or the students taken out to experience it. This is not always possible and pictures may be needed for the following reasons:

1. Size limitations
2. Environmental conditions
3. Geographical difficulties
4. Complexity of the subject matter
5. Time compaction
6. Need to extend experience

1.421 Size limitation

Sometimes the real thing may be too small (for example, the circuitry of a micro-chip) - microphotography enables a representation of this technological advance to be appreciated. On the other hand, the real thing is often too large to be understood - for example, an oil refinery - even after an educational visit. Thus, if the purpose of such a visit is to understand the workings of the refinery, pictures and diagrams showing how the plant was laid out and how the processes worked might be a more appropriate substitute.

1.422 Environmental conditions

Sometimes direct experience of an event or situation may be too dangerous to consider. For example, a factory visit might involve visitors in exposure to dangerous fumes. Subjecting people to hazardous conditions is not educationally justifiable and the use of slides or films to demonstrate the process might be more suitable.

1.423 Geographical difficulties

Time, cost and other geographical constraints often rule out the possibility of direct experience and so a representation of reality with pictures, models or diagrams might accomplish a desired objective more quickly and cheaply.

1.424 Complexity of the subject matter

Modern society is very dependent on machines. The complexity of machinery often needs a motion film to explain the movement and synchronisation of the component parts. In such cases motion pictures may give

a better understanding than actually seeing the real thing. Movement can be speeded up or slowed down or 'frozen' to further improve understanding.

1.425 Time compaction

As time progresses, reality changes. Consequently, many events and objects that were once of interest no longer exist. With the aid of pictures, historical events can be 're-created', compacted in time and incidents recaptured in a more interesting way than can be achieved by merely talking about them. Life cycles of natural phenomena, such as those of plants and flowers, can be illustrated with special techniques such as time lapse photography.

1.426 Need to extend experience

There are certain pictorial techniques which permit extension of experience beyond that which an individual might normally expect to encounter. For example, infra-red photography enables things to be seen in the dark and X-ray photography reveals bone structures. Similarly, the technique of animation assists understanding of processes which are not only impossible to see but which cannot be filmed. For example, it would be difficult to film the flow of a fluid around an aerofoil or any other obstruction to the flow.

From the above it is clear that in certain circumstances pictures can be even more useful for teaching than direct experience. However, not all pictures are useful. The proverb 'A picture is worth a thousand words' can be misleading. It could be worth more or it could be worth less. It depends on the picture and how it is used.

1.5 RETENTION OF VISUAL INFORMATION

The human mind has several input channels; it is thus able to accept information in a variety of forms. Communication

between human beings is through the senses, the most powerful of which is sight (Karch, 1976, Ref. 6).

In competition with other senses, sight dominates in the reception of information, a factor that needs to be taken into account in the design and production of materials to aid the communication process.

Some experiments carried out at the University of Rochester in 1970 by Haber, Standing and Erdelyi (1970, Ref. 7) indicate that linguistic and pictorial memory differ substantially.

Retention of information depends upon whether images are pictorial (scenes, photographs and so forth) or linguistic (words, numbers).

Haber and his colleagues studied the process of visual memory in human subjects using several tools. These included tachistoscopes (devices that can display a series of images in rapid succession), slide projectors and screens, instruments for following eye movements, instruments for measuring the time needed to respond to stimuli, and various kinds of pictorial and linguistic material. Their experiments revealed several important characteristics of the visual memory process. Among the most significant of these findings is the suggestion that there is one kind of memory for pictorial material and another for linguistic. They suggest that the capacity of memory for pictures may be unlimited.

This is supported in another experiment which Haber and Standing made in order to measure visual memory capacity.

Subjects were shown 2,560 photographic slides at the rate of one every ten seconds during viewing sessions held on consecutive days. Suspecting that fatigue might have some effect upon performance, all volunteers followed a rigorous viewing schedule that consisted of looking at 1,280 pictures a day during four hour sessions on consecutive days. One hour after the subject had seen the last of the slides he was shown 280 pairs of pictures. One member of each pair was a picture from the series the

subject had already seen. The other was from a similar set, but it had never been shown to the subject. When the subjects were asked to say which of the two pictures they had seen before, 85 to 95 per cent of the choices were correct.

One implication of the findings from these experiments was that if techniques could be found to facilitate the attachment of words to visual images, recall of the words might dramatically improve.

1.6 USES OF MEDIA FOR LEARNING

As a medium is the means by which a message is conveyed, all media are effectively tools of learning. They are also tools of communication which are widely available for use in libraries and in the home.

The following possible uses for media for learning are suggested by Harris (1979, Ref. 8):

1. Engaging the students' motivation
2. Revision of work already covered
3. Providing new learning stimuli
4. Activating students' responses
5. 'Comment' on students' responses
(replay of a student's own performance such as a language laboratory, or a video recording in a role-playing situation)
6. Manipulation of size, time, distance, attention and amount of information available

The effective use of media depends upon a number of factors such as the overall characteristics of the teaching or training situation, the course objectives and content and various practical considerations such as availability of equipment. These and other criteria for selecting appropriate media are discussed in more detail in Chapter 5.

1.61 Classification of Types of Information Carrier

An attempt to classify the different types of communication media has been made by Fothergill and Butchart (1978, Ref. 9).

This classification is based upon the desirable characteristics that they should possess as information carriers. The media should be:

1. capable of individual use
2. capable of broadcasting to a large group
3. capable of storing information prepared by national or international producers
4. capable of storing information prepared and arranged by the private user and local producer with the minimal processing
5. capable of securing the information to prevent accidental loss or replacement

There is some speculation that in order to meet these criteria, the types of media that will be available will eventually be reduced to four basic types:

1. Paper collection
2. Microfiche for still pictures
3. Sound cassettes for sound recordings
4. Video cassettes for moving pictures

Each of the above can be used in the home, broadcast by projection or amplification to a larger group, can be purchased with information already on them, or created by the user recording his own information, and are reasonably secure against accidental erasure.

Unfortunately, the list of desirable properties presented by Fothergill and Butchart does not include the potential of the medium for the support of bi-directional interaction. Furthermore, the final taxonomy completely neglects the possible use of the computer as a storage medium and channel of communication.

1.62 **Types of Communication Channel**

The concept of a communication channel was introduced in section 1.37. Based upon the explanation that was given there and the subsequent material that has been presented, two important points now emerge: a communication channel carries information, and there is a wide variety of such channels currently available. Some of these are listed in Figure 1 (Barker and Yeates, 1980, Ref. 10).

The list shown in the diagram is not exhaustive and shows the source and destination of information and the direction of information flow. Some of the materials are 'interactive' in that there is bi-directional information flow between the communicating entities.

In this type of communication, the messages transmitted by one entity usually have a significant influence on the subsequent messages transmitted by the other.

1.63 **The Role of the Computer as an Audio-Visual Resource**

The role of the computer as an audio-visual/multi-media resource has been described in some detail by Barker (1979, Ref. 11). In this work the author attempted to provide an informal ranking of a series of communication media in terms of their 'interactivity' and capacity to communicate information.

The term 'interactivity' is used to describe the balance and frequency of information flow between an information donor and recipient. High interactivity is achieved when the roles of donor and recipient interchange with substantial rapidity.

A book/reader combination has low interactivity since the book is always the donor and the reader the recipient. In contrast, a computer terminal/user combination has a high interactivity because the roles of donor and recipient are constantly interchanging.

Barker's original list of communication media, slightly modified (*)

MULTI-MEDIA COMMUNICATION CHANNELS

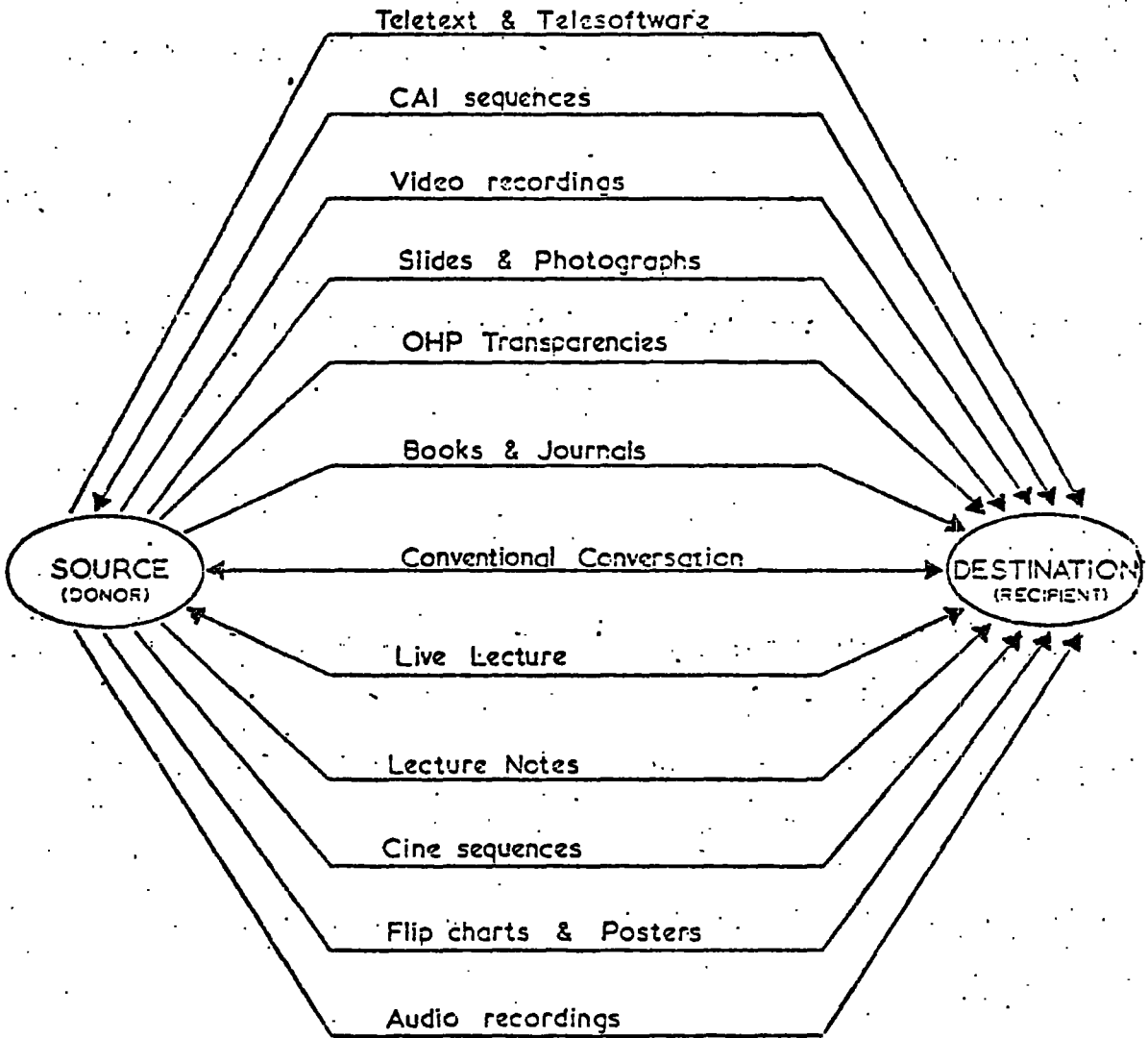

Figure 1.1

by Barker and Yeates (1980, Ref. 10), is given below:

- (1) printed tables
- (2) printed narrative
- (3) recorded spoken narrative
- (4) live spoken narrative
- (5) still pictures and graphs
- (6) silent motion pictures
- (7) recorded spoken narrative with pictures
(tape/slide)
- (8) live spoken narrative with pictures
(an illustrated lecture)
- (9) sound motion pictures or video recordings
- * (10) man-computer communication through a
computer terminal
- (11) one to many live tutorial (with 'props')
- (12) one to one live tutorial (with 'props')
- * (13) integrated multi-media communication techniques

The above list is not strictly homogeneous and suffers from the problems of terminology outlined in the introduction to this thesis.

For example, a printed table, although it is an information carrier, can itself be 'carried' by other media such as a blackboard, page of a book, slide, overhead projector transparency, TV programme, etc. It thus appears that there are many levels of information carrier available and any particular communication channel may consist of a complex combination of these. All the above media however have their strengths and weaknesses. This is discussed in Chapter 2.

In the above table, item 10, man-computer communication through a computer terminal, not only includes conventional keyboard interaction through a visual display unit or teletypewriter, but also encompasses interaction via sophisticated graphical techniques and the use of specially designed terminals for business or home use - this may be a modified TV set in the latter case. Thus this category of communication channel will include the use of powerful interactive systems' such as PLATO (Programmed Logic

for Automatic Teaching Operation) (Ref. 12) and TICCIT (Time-shared Interactive Computer Controlled Information Television) (Ref. 10) and other types of teletext channels such as CEEFAX, ORACLE, VIEWDATA and sophisticated systems such as the CYCLOPS system (Ref. 13) that is currently being developed by the Open University in the United Kingdom.

All of these systems are able to support individual interaction thereby providing a highly interactive medium for debate and discussion (computer conferencing, tele-conferencing, electronic mail), through the medium of a distributed computer network.

The potential of man-computer interaction via a terminal is quite substantial; it has been discussed in considerable detail by such authors as Martin (1971, Ref. 14) and Hiltz (1978, Ref. 15).

1.64 **The Need for Integrated Multi-Media Communication**

Learning has been defined (Veal, 1979, Ref. 16) as "impressing upon the subconscious stimuli calculated to leave a lasting image, which may be called upon at any time by the conscious mind".

These impressions are received through the five senses - however for information transfer taste and smell are hardly applicable. Sight, hearing and touch are the main channels used for practical exercises.

The term 'integrated multi-media communication' is chosen to describe those communicative methods that are composed of any combination of items 1 through 13 (see previous list) used together, or in sequence, in order to disseminate a message (or sequence of messages) to a recipient group. In addition to delivering the message, such integrated channels may be required to provide facilities to determine how effectively the message has been received. There will thus need to be a certain degree of bi-directional information flow associated with this type of communication channel.

As an illustrative example of the multi-media approach to

communication using currently available technology, the following example is quoted in Barker & Yeates (1980, Ref. 10).

Consider a communication strategy based upon the following sequence of events having duration t_i

1. Live oral presentation
2. Slide sequence with recorded narration
3. Use of flip chart with OHP and live narration
4. Presentation of an animated sequence by means of cine
5. Demonstration of a simulation using a computer terminal
6. Group discussion

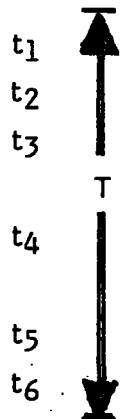

In (3) there is a certain degree of parallelism involved since the flip chart is used in conjunction with an overhead transparency projector while narration is undertaken. As greater degrees of parallelism are introduced into a communication strategy, the problems of synchronisation, switching between channels and continuity can become quite significant. Consequently, this is an area where the computer could be of substantial utility, namely, the design, evaluation, optimisation and control of instructional strategies.

In the example shown above, the capacities of the various channels that contribute to the overall message passing strategy will need to be known if timing elements (t_i) are to be determined. These will be important if their contributions are to be optimized with respect to the time constraint

$$t_1 + t_2 + t_3 + t_4 + t_5 + t_6 \leq T$$

In other words, if there is only a limited time during which a message is to be passed, an optimal use of any/all channels may be necessary in order to produce a predetermined 'success rate' within a given receptor group.

1.7 CONCLUSION

There is a wide variety of communication channels available to aid the communication process between two (or more) people. The meaning of the term 'channel' in the context of this thesis has been presented. Selected combinations of the available channels are referred to by the term 'multi-media'. The basis for the use of multi-media communication strategies has been outlined and some justification for their use presented.

As a consequence of the importance of these techniques, over the years a substantial volume of knowledge/information has been committed to storage on a variety of media. Collectively, these are referred to as multi-media resources. The stored material may contain much that could be of value to those involved in creating communication strategies, for example, a teacher, a technical instructor, a lecturer, a broadcaster, and so on.

In order to make these resources easily available there is a growing need for suitable 'storage archives' that are able to provide easy access to them. These may be organised for both central and personal use. The concept of a multi-media data base has been introduced (Ref. 10) in an attempt to rationalise and integrate the use of these resources, thus providing a mechanism for the construction of optimal communication strategies for use in teaching and learning environments. Subsequent chapters of this thesis will describe some approaches that have been made towards the provision of facilities for sharing multi-media resources (PLATO, CYCLOPS, etc.). Later in this thesis a multi-media communication experiment will be described (Chapter 6) in which the need for such a data base becomes apparent.

REFERENCES

- (1) Williams, P. and Pearce, J.T., The Vital Network: A Theory of Communication and Society, Greenwood Press, ISBN: 0-313-20324-5, 1978
- (2) Maude, B., Practical Communication for Managers, Longman, 1974
- (3) Dance, F.E.X., The Concept of Communication, Journal of Communication, Vol.20, 201-210, 1970
- (4) Parry, J., The Psychology of Human Communication, University of London Press, 1967
- (5) Miller, G.A., The Psychology of Communication, Penguin, 1970
- (6) Karch, K., The Multi-Vision Manual, Dietzer Gitzel Publishers, Karlsruhe, 1976
- (7) Haber, Standing and Erdelyi, How We Remember What We See, Scientific American, 104-112, May 1970
- (8) Harris, N.D.C., Preparing Educational Materials, Croom Helm, 1979
- (9) Fothergill, R. and Butchart, I., Non-Book Materials in Libraries: A Practical Guide, Bingley, 1978
- (10) Barker, P.G. and Yeates, H., Problems Associated with Multi-Media Data Base Systems, IEEE Frontiers in Education Conference, 1980
- (11) Barker, P.G., The Computer as an Audio-Visual Resource, Computers and Education, Vol.3 23-34, Pergamon Press Ltd., 1979
- (12) Bitzer, D.L., The Wide World of Computer Based Education, Advances in Computers, Vol.15, p.240, 1976
- (13) Barker, P.G. and Yeates, H., A Guidebook to Teletext Systems, An Interactive Systems Group Publication, 1980
- (14) Martin, J., Design of Man-Computer Dialogues, Prentice-Hall, 1973
- (15) Hiltz, R.S. and Turrof, M., The Network Nation - Human Communication via Computer, Addison Wesley, 1978
- (16) Veal, M., Using Animation in Video-based Training Methods, Computer Weekly, p.52, November 1979

CHAPTER 2
USE OF CONVENTIONAL MEDIA

- 2.1 Introduction
- 2.2 Categories of Media
- 2.3 Functions of Educational Media
- 2.4 Reasons for Using a Variety of Media
 - 2.41 Print Media
 - 2.42 Tape/Slide
 - 2.43 Tape/Microfiche
 - 2.44 Video
- 2.5 The Passive Nature of Conventional Media

CHAPTER 2

USE OF CONVENTIONAL MEDIA

2.1 INTRODUCTION

The term media was defined earlier as being the means by which a message is conveyed. Computer Assisted Learning (CAL), like other teaching methods, has many unique properties. These should be compared with alternative methods of learning, all of which have their own useful qualities.

CAL is only one of many tools that the teacher can use to help with his teaching and learning problems. Typically it will support, or be supported, by other media such as printed materials, lectures, tutorials and a wide range of alternative non-book media.

Each type of media has its particular advantages and disadvantages. This chapter describes some of the advantages and limitations of conventional media.

2.2 CATEGORIES OF MEDIA

As nearly all media in education and training are sensed by the ears or eyes, "audiovisual media" has come to be used as a generic term. However, emphasis should be placed on the end intended, and the term "learning media" would seem to be more appropriate.

Media has been categorised into six 'levels' by Finn (1967, Ref. 1):

1. Tool level. Devices that aid the teacher to continue his normal teaching operations.

2. Data level. Information storage devices (microfiche, videotape, etc.).
3. Behavioural control level. Programmed learning devices.
4. Meaning level. Devices that relate to meaning (motion picture film, slides, etc.).
5. Research level. Devices for research activities (dialect recording, high speed photography, etc.).
6. Systems level. A media package, such as computer based learning, to achieve precisely defined objectives.

Educational media have been further categorised into low and high technology domains by Berman (1973, Ref. 2).

The information input of a low technology medium is under the direct influence of the teacher. The medium is relatively inexpensive, highly responsive to student feedback and may be edited by the teacher without the aid of specialists.

Examples of low technology media are printed matter including expository texts and programmed manuals, slides, tape recordings and overhead projector transparencies, especially if teacher generated.

A high technology medium is relatively expensive, requires expert assistance for information updating, and generally subordinates the teacher's role. Because of the overall cost and inflexibility, high technology media have tended to develop a greater authoritarian bias.

Examples of high technology media are computer based learning systems and packaged video courses.

Equipment such as teaching machines and motion picture projections may fall into either of the above categories depending upon the extent to which the local teacher's functions are

displayed by the medium. A teacher is generally able to select appropriate textbook sections, slides, or a single concept film. However, he is not at liberty to edit filmed courses or interfere with the inside of a teaching machine.

The classification of media emphasising levels of representation is well documented and generally falls into the following categories:

1. Direct experience. Learning by direct experience of a situation is probably the most useful - experience with real objects, people and events. Other categories are usually subordinate and are often representations of the 'real thing'.
2. Tactile representations Three dimensional representations of reality - examples are raised maps, solar system models, statues and toy trains.
3. Visual representations These are usually divided into two broad categories, kinetic and static.

Kinetic categories cover two and three dimensional forms. Examples of three dimensional forms are holograms and computer generated stereoscopic displays. Two dimensional displays include front or rear projects of motion pictures, television and computer generated pictures.

Static displays can also be two or three dimensional. Typical two dimensional displays are photographs, rear-illuminated transparencies, overhead projected transparencies and programmed learning devices.

Three dimensional displays include holographic replication, polaroid and bichromatic projections.

4. Auditory representations Such as music, tones and sound effects, narration and dialogue conveyed by speech devices and by telephonic and telegraphic methods.

5. Simulations Examples are simulations of an aircraft cockpit or of a nuclear reactor. There are also voice and music synthesizers, games and artificial taste and smells.

Programmed learning devices may be considered to lie within virtually all areas of 2 through 4 above, although their emphasis is in 3.

2.3 FUNCTIONS OF EDUCATIONAL MEDIA

Learning media have several functions:

1. Recording, to permit the future reconstruction of events taking place in the present to be reproduced at a later time.
2. Display, to permit groups or individuals to receive information at convenient times and locations.
3. Manipulative, to permit the observation of events which are normally unobservable to the senses.
4. Stimulation, for example, to arrange the environment aesthetically or otherwise uniquely to increase motivation.
5. Evaluative, to interpret responses of students in relation to a variety of variables including personality and potential for learning. Teachers may evaluate their own performance as well. For example, in closed circuit television teaching where a teacher can observe his own mannerisms.

Media can be used to transmit students' responses in class. These range from simple devices such as holding up colour coded cards in reply to multiple choice questions, or by the use of more elaborate devices that send an electric signal from the student's position to the teacher's desk.

2.4 REASONS FOR USING A VARIETY OF MEDIA

A communication strategy based upon a variety of media has been illustrated earlier (Section 1.64). Each medium should be used appropriately to obtain the greatest benefit from it.

Rushby (1979, Ref. 3) suggests that the significant matters to be considered are:

1. Appropriate use
2. Financial constraints
3. Variety

Appropriate Use

An example of appropriate use is the background information required by the student prior to carrying out a CAL simulation. This could be presented as part of the CAL program on the student's terminal or could be printed as a set of student's notes which the student could study away from the terminal. In the former case the computer is being used as an automated page turner and it may be more appropriate to use the latter approach.

Financial Constraints

The appropriate use of technology is bound by financial constraints. While printed material is relatively cheap, the use of CAL and other aids such as closed circuit television is expensive and must be deployed with care to be cost effective.

Often a course may have to be mounted within a training budget. Suppose, for example, that a course was reduced in length by 10 per cent, saving staff time, student time and resources. If in this case the results in examinations and tests showed only a marginal deterioration, the result is cost effective when cost is a significant factor.

Teachers and instructors are also very expensive and they too should be employed appropriately.

Variety

Motivation is a term used to indicate the willingness of a learner

to learn. A very willing student is said to be highly motivated. One way of increasing motivation is to introduce a variety of media because, as previously stated (2.3) a function of learning media is that it is stimulative. The variety obtained by using a combination of different media and teaching styles can provide the necessary stimuli mentioned by Veal (1979, Ref. 4).

To use media effectively the educator should be guided by an understanding of the requirements of the modern student and discover what stimulates him, how he learns and what maintains his interest.

So far as the requirements of the teacher are concerned, the motivation for the use of multi-media communication techniques stems from the high bandwidth for information transfer and its consequent effects upon the retention of the information that is transferred.

The comparative figures shown below (Veal, 1979, Ref. 4) are claimed to be typical of the results that have been found in many different surveys:

Retention of information provided by:

(a) Textbooks	30%
(b) Lectures	40%
(c) Multi-media methods	80-90%

Some examples of strengths and weaknesses of typical media are given below.

2.41 Print Media

Historically, the written and spoken word have been the accepted means of communication. The importance of the written word lies in the fact that it is "recorded" and has a lasting influence - perhaps over centuries. Printed materials (books, periodicals, pamphlets, etc.) are thus very important carriers of information. The importance of the book arises in many ways from its high convenience value. It is easily transported and thus can be accessed in a wide variety of situations in which other

communication resources could not be used.

A weakness of the printed word is that it is a passive aid to learning. There is no interaction with the user. Another weakness is that unfortunately many books are outdated almost as they are printed because of the rapid expansion of information and its short half life.

The work of Gustav Thuro (1977, Ref. 5) is interesting in this context. He has proposed a continuous revision and updating process for text books in his SPOC (System of POlyvalent Curricula) project. At the moment students and others who want to learn about the latest state of knowledge in a particular subject are confronted with a difficult and time consuming task. They have to study and evaluate a great number of information sources of different quality containing different theories and opinions. The aim of this international project is to develop a high quality system of interrelated textbooks. The project is being planned by an initiative group consisting of 82 experts from 29 countries. The intention is that the SPOC textbooks would be constantly adjusted to the latest state of scientific development. The SPOC project envisages international standardisation of examination requirements, qualifications and modular educational programmes.

One immense problem the project would have to overcome would be the physical production and dissemination of printed material to meet the continuous adaptation of the standardised curricula that is proposed - presumably in many languages.

Despite the importance of the printed word, the impact of new learning media during the past two decades has been considerable.

Berman (1973, Ref. 2) suggests that as information becomes more and more fragmented and interrelated, textbooks may indeed be replaced by multi-media packages consisting essentially of printed materials but supplemented by holograms, audio and video cassettes and thin plastic recording discs.

Of particular interest is the work of the Open University as this is the first full-scale multi-media system of higher education (compare project SPOC above). Students become involved with television and radio programmes, sound cassettes, still photographs, specimens and videotapes. Materials are supplied in kit form for flexibility and convenience and have unusually clear and attractive multiple coloured formats that add to the stimulation and motivation of the student.

As a producer of multi-media learning packages, the Open University collaborates with many other educational and professional organisations.

The simplest productions are combinations of two items, sound tape and slides, filmstrip and booklet, but some kits are considerable collections of different formats. An interesting example mentioned by Fothergill (1978, Ref. 6) relates to a kit prepared on child abuse by Newcastle upon Tyne Polytechnic in conjunction with the Open University. This particular package contains twenty items, including two books, small instruction cards, small booklets, two plays, a pack of special playing cards, three sound tapes and a set of slides.

The Open University is also committed to the development of CAL, and their CYCLOPS project is described in Chapter 4.

2.42 **Tape/Slide**

The combination of tape and slide is also a passive medium but one which gives a large information bandwidth. This means that the student can receive information at a fast rate by looking at detailed pictures, diagrams, charts, etc. and listening to a synchronised commentary. The medium can be used for individuals or groups as modern projectors have front and rear projection incorporated in one device. Slides can be used to show a sequence of steps and learning can be self-paced. A further advantage is that updating is relatively easy compared with videotape or film and they are of relatively low cost when compared with other types of film media. The use of sound

recording also allows the author to inject more variety and realism into the presentation. The sound track can thus include recordings of different situations and people instead of printed quotations and word pictures.

In a British Library Research and Development Report (1977, Ref. 7) other advantages claimed for tape/slides were that they were robust in terms of normal handling, they had flexibility over other systems in that the equipment was easy to use and reasonably well standardised and that they improved the quality of teaching and training. The weaknesses quoted in the above report were that tape/slides take time to prepare and produce, that many teachers feel inexperienced in the use of visual materials for instruction and in awareness of techniques for graphic art. The limitations of room darkening have been alleviated to a great extent by using modern photographic techniques and equipment. These will be described later in Chapter 6 on the design and production of a multi-media experiment which utilises tape/slide as a component in a CAL package. Tape/slides are, of course, more sensitive to damage than printed materials but the use of this specialised media is now widespread in educational establishments and libraries because the combined impact of the visual stimulus together with the audio stimulus perform a much more efficient communication function than either audiotapes or slides can perform alone. It is the combination of the two channels where one reinforces the other that gives this relatively low cost medium its greatest strength.

2.43 **Tape/Microfiche**

With the recent development of colour microfiche it is probable that colour slides might be produced in this format, particularly where they are used for private or small group viewing.

This has led to the development of a tape/microfiche system, similar in programme construction to a tape-slide (Bauch, 1979, Ref. 8). The development is not yet widely marketed, but it offers some advantages over tape-slide. Because the system allows easy random access to each frame on the fiche, the order

of the pictures can be altered without any change of the fiche itself. The speed of frame change is so fast that there is virtually no visible gap in viewing, hereby eliminating the discontinuities observed when using slide projectors. A further advantage is that the present system is linked to a standard stereo cassette tape recorder, therefore special equipment is not required.

This development is an interesting one as the storage/retrieval problems for a colour microfiche are much less than for a set of slides. A postcard size microfiche is almost the equivalent of a slide magazine. It contains a minimum of 60 images, each one measuring 11.5 x 16.75 mm. A pack of microfiche measuring only one inch in thickness can contain a minimum of 6,000 images. The duplicating of a microfiche is about one-tenth of the cost of the same number of original size (35mm.) slide duplicates. Postage costs are also lower for this type of slide storage.

Because of the above advantages there are automated microfiche systems now available which can be computer controlled. One such application is a CAL system being developed in California for training US Navy personnel. This system is described in Chapter 5.

It is probable that as colour microfiche becomes more widely used, this method will ultimately supersede the tape/slide systems now available.

2.44 **Video**

Video recordings and film material can offer further improvements in the speed and quality of presentation of material. It is sometimes essential to explain moving phenomena and relationships in a way that cannot be done using other techniques. Animation can produce a greater impact on an audience and it can be used for group or individual presentation.

The costs of production and delivery are much greater than for

printed materials or tapeslide and in addition the equipment is more complex and less reliable. It lacks portability so that presentation is confined to a given study area. While it has repeatability and a particular sequence can be shown an unlimited number of times, the medium is still passive because it cannot respond differently to each student or vary its approach to take account of a student's individual problems. In terms of updating and revision it lacks the flexibility of tapeslide. Despite the above weaknesses, video recorded materials are in wide use both as an entertainment and educational and training medium.

2.5 THE PASSIVE NATURE OF CONVENTIONAL MEDIA

In summary, devices of various kinds which store, retrieve, or manipulate information in the form of messages embedded in a medium have been in existence for a long time. People use them to communicate ideas and feelings both to others and back to themselves. Every message is a representation of an idea.

Although thinking goes on in one's head, external media serve to materialise thoughts and, through feedback, to augment the actual paths the thinking follows. Methods discovered in one medium provide metaphors or images which contribute new ways to think about notions in other media.

For most of recorded history the interactions of humans with their media have been relatively passive. For example, marks on paper, paint on walls (more so motion pictures and television) do not change in response to the viewer's wishes.

The essence of a medium is very much dependent on the way messages are embedded, changed and viewed. Although digital computers were designed to do arithmetic computation, they now have the ability to simulate the details of any descriptive model. This means that the computer, viewed as a medium itself, can be all other media if the embedding and viewing methods are sufficiently well provided.

Kay and Goldberg (1977, Ref. 9) are working on a computer controlled multi-media device called a 'Dynabook'. They have used the term 'metamedium' for this new communication tool and have stressed that it is interactive. It can respond to queries and experiments so that the messages may involve the learner in a two-way conversation. They observe that this property has never been available before except through the medium of an individual teacher.

Their 'Dynabook' is visualised as a self-contained knowledge manipulator in a portable package the size and shape of an ordinary notebook. It would have enough power to outrace our senses of sight and hearing. Its capacity enables it to store for later retrieval thousands of page equivalents of reference materials. Examples given are poems, letters, recipes, records, drawings, animations, musical scores, waveforms, dynamic simulations, in fact anything that needs to be remembered or changed.

Other developments in 'metamedium' devices are described in Chapter 4.

REFERENCES

- (1) Finn, J.D., A Possible Model for Considering the Use of Media in Higher Education, AVCR, 15, 153-7, 1967
- (2) Berman, A.I., Learning Media, Theory, selection and utilisation in science education, Institute of Studies in Higher Education, University of Copenhagen, 1973
- (3) Rushby, N.J., An Introduction to Educational Computing, Croom Helm Ltd., ISBN 0-85664-813-2, 1979
- (4) Veal, M., Using Animation in Video-based Training Methods, Computer Weekly, p.52, November 1979
- (5) Thuro, G., System of Polyvalent Curricula (SPOC), Fachhochschule Hamburg, Germany, 1977
- (6) Fothergill, R. and Butchart, I., Non-Book Materials in Libraries: A Practical Guide, Bingley, 1978
- (7) Hills, P.J., Lincoln, L., Turner, L.P., Evaluation of Tape-Slide Guides for Library Instruction, British Library Research and Development Report 5378 HC, August 1977
- (8) Bauch, F.W.O., Ltd., Boreham Wood, Herts., 1979
- (9) Kay, A. and Goldberg, A., Personal Dynamic Media, Xerox Palo Alto Research Center, Technical Report No. SS176-1, March 1976

CHAPTER 3

THE USE OF THE COMPUTER AS AN INSTRUCTIONAL TOOL

3.1 Historical Background

3.11 Developments in USA

3.12 Developments in Europe

3.2 The Use of Author Languages

3.3 Modes of Use

3.31 Performance Uses

A. Presentation and Review of Information

1. Tutorial Mode
2. Inquiry Mode
3. Drill and Practice

B. Development of Intellectual Skills

1. Inquiry
2. Socratic (Dialogue)
3. Simulation
4. Gaming

3.32 Management Uses

- A. Monitoring and Recording
- B. Testing and Prescription

3.33 Comprehensive Uses: Summary

CHAPTER 3

THE USE OF THE COMPUTER AS AN INSTRUCTIONAL TOOL

3.1 HISTORICAL BACKGROUND

3.1.1 Developments in the USA

The United States of America, in the 1950's, was probably the first to study the instructional uses of the computer. The term Computer Aided Instruction (or CAI) is often used to refer to the use of the computer for instructional purposes. Developments in CAI arose out of the work of Skinner at Harvard University (Ref. 1) who originated a technique called Programmed Instruction.

This proposed that the best way of learning the subject material was to divide the learning task into many small tasks and then to concentrate upon each of these in turn. The student would be given a reward to reinforce his learning each time he demonstrated that he had mastered one of these tasks. He would then be allowed to progress to the next. If he encountered problems on a particular task, then he would be restrained at that point until he had mastered it. Alternatively, he could be directed to some remedial work in which the task was presented in a different way or possibly divided into even smaller parts.

Skinner's original theory has since been modified and embodied in other theories which form the basis of present-day programmed learning which seeks to rationalise the teaching/learning process. Programmed instruction involves the design of self-instructional learning materials which have some or all of the following characteristics:

1. An analysis prepared by the author/instructor or teacher of the expected performance of the learner on completion of the study assignment

2. Carefully defined behavioural objectives to show that he had learnt the material
3. Design of a specific criterion-referenced test for the material
4. The requirement of a minimum acceptable test performance on completion of the learning
5. The provision of information to students on their performance at various times during the learning sequence
6. Pilot trials using the material on an equivalent group of learners.

Special 'teaching machines' were devised and marketed which stored and presented the programmed instruction lessons to the student. The teaching machines were rather cumbersome and limited in the amount of 'branching', that is, the direction of the student to specific 'frames' (or logical series of parts) that they could permit.

Teaching machines were usually restricted to multiple choice questions. By contrast, the development of CAI was potentially more flexible. The computer could be programmed to 'understand' a wider range of responses from the student at the terminal. It was hoped that the computer would remove the resistance to programmed instruction techniques which was becoming noticeable in both the education and training markets.

The earliest computer assisted instruction program is thought to be that developed at the IBM Research Centre in the late 1950's (Rath et. al., 1959, Ref. 2). It was part of a project concerned with basic psychological research in memory and learning.

Interest in the psychological variables that are important in the design of teaching machines led to a project for the simulation of a teaching machine on a digital computer. The subject matter selected was binary arithmetic, and the program ran on an IBM 650 computer with a typewriter inquiry station.

The student was presented with problems and he typed in the answers. Answers were checked as each character was entered. If an error resulted, the machine assumed control and typed out the word 'wrong'. An incorrect answer caused generation of another problem of similar difficulty. After a number of incorrect answers, a problem of lesser difficulty would be generated.

Although it was realised that better utilisation could be made of machine time by connecting a number of separate consoles simultaneously, the project was essentially looked on as a method of simulating teaching machines. The aim was that their important features could be studied more closely.

Nevertheless, this experiment suggested the potential benefit of the computer as a more flexible teaching machine, and a number of similar projects were initiated. This use of the computer as an automated teaching machine dominated applications in the early 1960's, with 'courseware' based on the techniques of programmed texts. Courseware is the term often used to describe teaching materials used in educational computing. It may be contrasted with hardware (the physical computer) and software (the programs that make the computer operate). One noteworthy example of an early computer system developed specifically for instructional applications is the IBM 1500 Instructional System (Bunderson & Dunham, 1968, Ref. 3). This system developed out of a joint project at IBM and the Institute of Mathematical Studies in the Social Sciences at Stanford University, and consists of only slightly modified standard IBM equipment.

The IBM 1500 Instructional System was probably the first CAL system to integrate multi-media learning techniques. It consisted of an IBM 1800 Central Processing Unit with bulk storage maintained on tape and interchangeable disks, a station controller and peripheral devices including a card reader and line printer. The student terminal interface consisted of a cathode ray tube (CRT), a typewriter keyboard, and a light pen. The light pen was the means by which touch probe responses could be made on the face of the CRT. There was also an image projector with a

capacity of 1000 slides which could be randomly accessed under computer control. A set of earphones and a microphone completed the multi-media resources available. Audio messages could be played to the student from a bank of audio-tape playing and recording devices. Audio messages with a playing time of three hours could be stored on each of the three track tapes. These could also be randomly accessed under computer control.

This system was subsequently placed in experimental use in 20 centres. The University of Texas used this system in a simulated laboratory concept which was claimed to be highly cost effective in the provision of laboratory facilities for 5000 students. The IBM 1500 system permitted simulation of three classical experiments. Each is programmed in such a manner that the student inputs variable values which he himself selects. The routines are augmented by CRT displays, coloured filmstrips and slides, and reference to textbooks and standard reference manuals. One program has a subroutine permitting the student to retrieve information needed in the exercises - for example, to have displayed a facsimile of the Periodic Chart of the Atomic Elements. The IBM 1500 system is not a regular IBM product any longer.

It was not until 1960 that the first university project was initiated. A committee formed at the University of Illinois to consider the possibility of using computers in teaching psychology, education and engineering was unable to reach agreement and concluded that nothing could be done. Their report was evaluated by Bitzer, who proposed the use of the computer initially for sorting and tracking student behaviour. An attempt to program a computer to teach computer programming was undertaken, resulting in the first PLATO system.

In the years since 1960 several other universities have developed major research programs and several dozen other institutions in the USA have significant commitments to computer applications in instruction.

The University of Illinois has progressed through the original PLATO system to PLATO II, III and IV with the aid of substantial USA federal government funding. The use of CAI as a research vehicle is still a major component of the Illinois program, as are the areas of writing course material, system hardware development, and the design of low-cost terminals to support a planned 4000 terminal system. CAL is more than just a means of administering programmed texts and the PLATO systems have been distinguished by the wide variety of courseware produced. Another distinguishing feature is the many modes of use employed. These will be described later along with examples of their use.

Another well-known series of projects began at Stanford University under the direction of Suppes (Ref. 4). In these projects, systems for elementary level teaching were developed and applied in several states in the USA. The Stanford work served as a basis for several other systems for teaching reading and basic arithmetic. The IBM 1500 Instructional System was used by about 400 students as part of their CAL instruction during 1968 (Atkinson & Wilson, 1969, Ref. 5). Stanford's major contribution in higher education has been a two-year introductory Russian course taught exclusively by computer and language laboratory sessions. Stanford has also received significant federal government funding.

The PLATO system is described in more detail in Chapter 4 as it adopts a unique integrated multi-media approach to CAL.

3.12 Developments in Europe

One of the earliest European national programmes was in West Germany where the government provided major support for the development of CAL between 1967 and 1975. The organisation of this national CAL project was complicated by a division of responsibility (Rushby, 1979, Chapter 2 Ref. 3).

In Germany, education services are provided by individual states while the responsibility for scientific research and development

lies with the federal government. Thus the development of CAL necessitated cooperation between the central government, who were concerned with the technical and research aspects, and local government, who carried out actual implementation. The final decision as to whether CAL should be adopted in the schools was left with local government. Inevitably, this divided responsibility led to some problems. At the end of the funding period local government was expected to take the ongoing costs of individual developments on to its local budgets.

The French National Experiment in educational computing began in 1970 and was directed towards secondary education. Its goal was to develop, not only teaching with computers, but also teaching about computers. Like much of the French education system, it was highly centralised and controlled by the Ministry of Education. Its strategy was to provide intensive in-service courses in computing and CAL for a nucleus of teachers and to provide them with computing facilities in their schools. The trained teachers are to produce CAL materials and disseminate their ideas and expertise to their colleagues. Coordination for the ongoing use and further development of CAL is under the aegis of the Ministry of Education.

The wide-scale development of CAL in the United Kingdom was first proposed in the late 1960's and was promoted by a non-government organisation called the National Development Programme in Computer Assisted Learning (NDPCAL). The effort was to be distributed over a five-year period with a funding of £2 million. The National Programme funded projects in a wide range of subject areas, both in secondary and tertiary education, and in military and industrial training.

Some 35 projects were set up, the majority in higher education and lesser numbers in schools, military and industrial training (Hooper & Toye, 1975, Ref. 6).

In Suffolk, history teachers developed the use of the computer for the manipulation of 19th Century census returns. In Glasgow, the University produced CAL materials for teaching medical

students (simulations of patient conditions). In Northern Ireland, the New University of Ulster pioneered computer managed learning (see Ref. 6) using the CAMOL (Computer Assisted Management of Learning) package written by ICL. In the RAF, the computer's ability to simulate expensive radar equipment and give remedial teaching was exploited. By the end of the programme, 47 UK institutions were using CAL. In addition, another 100 were developing project materials. A Final Report of the National Programme was prepared by the Director, R. Hooper (1977, Ref. 7). This indicated that by the end of the Programme, 70% of the project institutions had decided to continue work with internal resources. The Programme laid considerable emphasis on evaluation of the projects and on their plans for long term survival. Also included were educational evaluations as well as a study of the financial and managerial performance of the projects. A key finding of the educational evaluators was the extent that CAL projects had moved away from the narrow type of programmed instruction. Another conclusion was the achievement of high level thinking and problem solving skills developed by the projects. The key findings from the financial evaluators were as follows:

1. The high cost of developing CAL (It takes anything from 40 to 400 hours to develop one hour of good validated teaching material.)
2. The impossibility of establishing quantifiable cost benefits

3.2 The Use of Author Languages

The person who writes learning packages is referred to as an 'author'. A programming language designed specifically for the task of writing CAL programs is called an 'author language'. However, many CAL packages have been written in general purpose languages such as ALGOL, FORTRAN, BASIC and COBOL. Each language has its group of adherents who often claim their particular choice has special merits which the others do not have. Choice of a programming language is often constrained by availability, rather than on relative merits. One advantage

usually claimed for general purpose languages is that programs written in such a language can be run on any computer for which the language is available. Unfortunately, computer languages, like natural languages, have dialects. Two dialects can differ so much that they might as well be two different languages. The use of a general purpose programming language is not a guarantee that the program can be transferred from one machine to another without alteration. Consequently there are those who favour languages designed specially for CAL applications. Their case is that special purpose author languages can simplify the task of writing CAL programs by including standard ways of carrying out standard operations. Such operations may include the following:

1. Matching a student's response against a list of expected responses while allowing for certain kinds of errors
2. Provide convenient ways of specifying the choice among alternative instructional material based on the student's responses
3. Provide for records of each individual student's progress by progressively adding the results of the latest assessment
4. Maintain statistics about the use of the program

Over 30 languages and dialects have been developed particularly for programming CAL. However, many of the differences between these languages are superficial; there are actually only three or four different kinds of languages. Despite the variety, some user needs are still unmet - see Zinn (1969, Ref. 9).

Examples of widely used author languages are PLATO's 'TUTOR', IBM's COURSEWRITER, and Sperry Univac's 'ASET' (Author System for Education and Training). The illustration in Figure 3.1 shows an extract from COURSEWRITER.

The above special purpose languages still suffer from the disadvantage that they can only be used on a particular manufacturer's machine. This can create problems for

APPEARANCE OF A CAL SCRIPT WRITTEN IN
AN AUTHOR LANGUAGE

QUESTION 1

qu What is the product of 12 and 3?
ca 36
ty correct
br question 4
wa 15
ty No, the answer you gave is the sum
 of 12 and 3. Try again!
un You have not answered correctly.
 Make sure that you type a numeric answer.
 Try again
 0
 0
 0
 0

COMMAND

ACTION

qu	question to student - await a reply
ca	anticipated correct answer
ty	type out
br	branch
wa	anticipated wrong answer
un	unanticipated answers

The above example is from IBM's COURSEWRITER

Figure 3.1

organisations who are using several makes of computer to meet different needs.

Whatever the limitations of programming languages, there has been considerable progress over the last 15 years.

A summary of developments in modes of use of CAL is described below. This illustrates how the status of author languages has moved beyond the 'programmed text' type of program which typified the pioneering efforts previously described.

3.3 MODES OF USE

The use of computers in the instructional process is very wide ranging. There is no single mode of use but rather three broad categories in which the computer participates in instruction.

These are:

1. Performance uses
2. Management uses
3. Comprehensive uses

3.31 Performance Uses

The computer may assist the student by performing three functions. First, it may facilitate the acquisition of information by presenting or reviewing instructional material. Second, it may assist in the development of intellectual skills. This is done by providing learning experiences and activities in which the student assumes an active role in problem solving, inquiry or decision making. And third, it may aid the instructional and learning process by facilitating research and computation. Only the first two functions will be described in more detail below. These deal with the capabilities of the computer for instructional purposes. The third use of the computer as a computational device and data store and manipulation tool will not be elaborated upon here.

A. Presentation and Review of Information

One of the first applications of the computer to the instructional process was the presentation and review of information.

Earlier experience with programmed texts and teaching machines often provided a model for initial instructional uses of the computer - see, for example, Holland & Hawkins (1972, Ref. 8). As experience has been gained, additional modes of instruction have been developed to facilitate presentation and review of information. These modes are called:

1. Tutorial
2. Inquiry
- and 3. Drill and Practice

A brief description of each mode is described below.

1. Tutorial Mode

In their simplest form, tutorial programs comprise a linear series of factual statements interspersed with predetermined questions and responses.

Each student, regardless of ability, performance or prior knowledge, is required to proceed through the same material. In their more complex form, tutorial programs are composed of parallel sequences of instruction at different levels of difficulty. In some cases the program is structured into three levels; the student can move from the mainstream of instruction to branching paths for remedial or enrichment material. Other programs have a series of instructional loops to which the student can branch briefly for remedial or supplemental study and then return to the main sequence of the program. The computer permits a much more complex branching structure than either programmed texts or conventional teaching machines. The focus of the instruction is on the subject material and on the student's mastery of the various concepts within it.

This mode was used to conduct the CAL experiment described in Chapter 6.

2. Inquiry Mode

While the tutorial mode has been the principal way of using the computer to present and review information for the student, some authors have felt that this mode makes the student too passive a participant in the instructional process. They favour a more active 'seeking out' or inquiring process for the learner.

For example, a learner-controlled unit in statistics, in which the student selects his own particular route through the course, was developed by IBM. Its author, Grubb (1969, Ref. 10), contends that it is as important to teach the structure of a subject as the content. In this IBM statistics course there is no 'correct' way to proceed through the material. Each student proceeds through the material in whatever fashion suits him. The major advantage claimed for this method is that the subject is completely under learner control rather than computer control.

3. Drill and Practice

Where course requirements and student performance call for reinforcement and remediation techniques, the drill and practice mode of computer instruction has become an effective aid. It is the most widely used mode of CAL in the banking industry where large numbers of trainees are taught keyboard and clerical skills using this method. More information is given on this application in Chapter 5.

Computer based drill can offer significant assistance to students expected to master a specialised vocabulary. Other uses are to demonstrate rapid recall of mathematical or scientific data. Similarly, practice sessions administered via terminals can offer an effective and motivating learning experience in mastering new skills such as speedwriting and speedtyping. A brief description of this drill and practice application is given in Chapter 5.

B. Development of Intellectual Skills

The computer's use as an aid to the development of intellectual skills occurs in four modes:

1. Inquiry
 2. Socratic (dialogue)
 3. Simulation
- and 4. Gaming

These are discussed below.

1. Development of Intellectual Skills - Inquiry Mode

In an inquiry mode, the student is usually called upon to solve a problem or answer a question by posing inquiries to a base of information embedded in a specialised program. The inquiry mode differs from the Socratic in that there is no dialogue with the computer: the computer only provides answers to the inquiries, based on information prestored in it or available to it through its own computational capabilities. The program makes no attempt to guide the student to the correct answer or conclusion. Usually, a situation is presented to the student. Using a specialised inquiry vocabulary, he asks for more data, eventually accumulating sufficient information to suggest a solution or draw a conclusion.

An interesting application of this technique with the PLATO system is described by Holland & Hawkins (1972, Ref. 8).

A PLATO program called REPLAB was used for a physics lesson in scientific inquiry based on the properties of a bimetal strip. The student inquires into the physical properties in order to describe, analyse, predict and control the physical phenomenon. An auxiliary film sequence displays the bimetal strip experiment, and a student at a terminal console has an opportunity to participate in five inquiry activities. He can answer questions, see the film again, experiment, check properties or check conditions.

The student selects his own approach and has the capability, through 24 special keyboard characters, to draw pictures on the terminal screen. The range of the PLATO system capability is described in more detail in Chapter 4.

2. Development of Intellectual Skills - Socratic Mode

The Socratic (dialogue) mode resembles the inquiry mode: the student controls the progress of the lesson, finding his own path through material made available to him by the computer. The Socratic technique extends the interaction of the student with the program by establishing a two-way 'conversation' between student and machine, usually via a typewriter keyboard. The student's question, assertion or request for data can result in any one of a wide variety of responses from the machine. The computer may pose a question to him, coach him to try a different approach, or guide him in a review of earlier or background material.

The following example is taken from a program devised by the Harvard Medical School (Holland & Hawkins, 1972, Ref. 8).

In a sample dialogue, the medical student assumes the role of an admitting physician in a hospital. A patient is brought in displaying a given set of symptoms and having a specified background. The student's task is to make a diagnosis on the basis of observation and a physical examination, and to prescribe treatment. He has available a vocabulary of questions and statements that he can pose to the computer. Included in this repertoire is the ability to request laboratory tests and various pieces of data (results of a chest examination, general appearance, temperature and blood pressure). An interesting aspect is the compressed time scale feature. Some of the laboratory tests ordered cannot be ready for some time, and in some cases not until the 'next' day. In the meantime the program will call upon the student to establish immediate treatment procedures and instructions for the night nurse. The 'next morning' the examination continues, based on a report the student asks for

(or will be coached to ask for) regarding the patient's condition after a night in the hospital. In addition, laboratory reports may be available. The entire dialogue requires only a few minutes at the typewriter console. At any point the student may attempt a diagnosis. If this is done prematurely, he may get a response such as "There's insufficient information for any conclusive diagnosis at this time. You're not being careful!".

3. Development of Intellectual Skills - Simulation Mode

Although direct experience is usually the best teacher, reality in education must often give way to factors of time, cost, safety and equipment availability. Simulation programs provide the student with artificial experience of a dynamic real-world environment. The student is usually called upon to take actions that affect the modelled situation. Computer-based simulation can represent a complex chemical reaction, a problem in physics, a diagnosis of patient illness, or the management of a large business firm. In simulation, there is usually no 'correct' solution producing a single optimum outcome. Simulated environments are dynamic, the goal being to achieve over some period of time the best possible set of policies. A simulator device is applicable where there is a risk factor, as in medicine; or where the costs or using the actual equipment are great, as in pilot training; or where it is impossible to obtain real-life experience, as in space travel.

The Medical School of the University of Southern California (Holland & Hawkins, 1972, Ref. 8) is using a computer controlled model to teach anaesthesia. The method is unique and consists of a physical dummy of a patient that is controlled by a computer. The lifelike model exhibits a wide variety of 'human' responses, including respiration, heartbeat and eye movements. The student applies his knowledge of anaesthesia to the dummy, which responds under the computer's control as would a live patient. The dummy is connected to various instruments and monitoring equipment that would be found in an actual operating room.

Students report that the reactions of the model are extremely realistic, even including tactile sensations derived from its 'skin'. A catastrophic mistake on the part of the student causes the patient to 'die'. This simulated patient has the advantage that the student gets reasonably extensive and realistic direct experience without risking the life of the actual patient. Although only one student can interact at a time with the model, it is always available and is programmed to reflect a large number of clinical situations. The model affords the student an opportunity to experience a much larger variety of cases than he would normally find in a teaching hospital. Evaluations using experimental and control groups demonstrated that the students using the model reached acceptable performance levels in a few days, with a smaller number of trials than the students taught by traditional methods.

4. Development of Intellectual Skills - Gaming Mode

A game involves competition between two or more players (one 'player' may be a computer program) to achieve a specific defined goal. In this way it differs from a simulation where there is usually no 'correct' solution producing a single, optimum outcome. Computer controlled games developed from games which have been popular for many years in industry as a training mechanism for executives and managers.

The computer often plays the role of an 'umpire' during the conduct of the game, assessing the moves and strategies of the players, keeping track of the various indices affected by the actions of the players, and introducing random variables. Thus, for instance, one player in a management game might declare a price increase for his 'company's' product. The computer determines the effect of the move on the firm's sales and profits; it might then inform the player that one of his factories has been substantially hit by a major fire, or it might declare a new corporation tax. Each player is thus faced with a constantly changing environment and is forced to react to the moves of the other players as well as

to new constraints imposed by the computer program. These games achieve intense student involvement and they are regarded as a valuable educational tool, especially at graduate level in economics and business.

3.32 Management Uses of the Computer

The term Computer Managed Instruction (CMI) is used when the computer is employed to give assistance to the teacher, instructor and administrator with the routine management tasks in teaching and learning. Two types of management use may be distinguished. In the first, the computer is used as an aid in the monitoring and recording of student performance (often referred to as Computer Monitored Instruction). In the second, the computer assists both in the monitoring and in the prescription of appropriate instructional materials for each student.

A. Monitoring and Recording

Teachers must keep records of student performance and achievement and use them in student and curriculum evaluation. When classes are small, this task is easily performed without computer assistance. In large lecture classes, however, the computer's clerical and analytical aid can relieve the teacher of a time-consuming management task thereby leaving him more time to devote to the essence of teaching. Class and student averages can be easily calculated by the computer. The availability of computer stored data opens the possibility of careful analyses of student and course performance. These analyses are valuable in providing each student with a diagnosis of his strengths and weaknesses on each course segment and the comparison of his performance with that of his fellow students. The teacher might receive, in addition to student evaluations, an analysis of those course segments (or examination questions) that caused greater than average difficulty for students. These computer-based monitoring and record-keeping systems are complementary to computer-based testing and self-evaluation systems of the kind described below.

B. Testing and Prescription

If sufficient time was available, many instructors would test students more frequently and would use the resulting information to adjust instruction to the performance and needs of their students. Testing systems provide information, on the basis of which instructional sequence decisions can be made. CMI can make a considerable contribution in this area in which the process of instruction is not managed by the computer alone but by teachers using conventional instructional aids, texts, records, films or television.

Computer managed instruction differs from the simpler computer monitored instruction by its greatly reduced dependence on whole class instruction through lectures.

Each student progresses at his own pace through the use of textbooks, supplementary readings, videotapes, films, and individual conferences with the teacher. While an instructor is always available, major reliance is placed on the individual student to use the instructional materials on his own initiative. The quality of computer managed instruction thus depends in some measure on the following requirements:

1. The ability of the system to identify and measure relevant student characteristics
2. The ability to design appropriate diagnostic tests
3. The availability of a sufficiently complete and varied set of instructional materials
4. The ability to associate with each possible combination of student characteristics and test performance an appropriate instructional segment

3.33 **Comprehensive Uses: Summary**

A comprehensive CAL system can be described as one providing several modes of assistance in instruction and management for a single course. For each subject, tutorial, drill, simulation, gaming, inquiry and Socratic programs can be made available. These aid the student in the presentation and review of information and the development of intellectual skills. To aid instruction, such a system can present on-line preparation and presentation of course material, incorporating computer generated films, graphic displays and other types of demonstrations. To aid both the student and the instructor, the system can provide a variety of monitoring, recording, testing, diagnostic and prescriptive capabilities.

Such a system offers a range of instructional potentials. In the extreme, one teacher might choose to disregard all available programs, while another might provide all course instruction via the computer. In an intermediate use, an instructor might elect to use a set of performance and management programs from year to year or from course to course. Here some programs might comprise integral parts of the instructional process, some might be supplementary, and others might be used for remediation.

Over the last decade the technologies of television, telecommunications and computers have been rapidly converging. The technology for such comprehensive systems with a multi-media integrated approach to CAL now exists. This is discussed in the next chapter.

REFERENCES

- (1) Skinner, B.F., Why We Need Teaching Machines, Harvard Educational Review No.31, 1961
- (2) Rath, G.J., Anderson, N. and Brainerd, R.C., The IBM Research Centre Teaching Machine Project, in Eugene Galanter (ed), Automatic Teaching - The State of the Art, John Wiley & Sons, Inc., New York, 1959, pp.117-130
- (3) Bunderson, C.V. and Dunham, J.L., The University of Texas Computer-Assisted Instruction Laboratory, 1967-1968, University of Texas, Austin, 1968
- (4) Suppes, P. et al, Computer Assisted Instruction: Stanford's 1965-66 Arithmetic Program, Stanford University Institute, Mathematical Studies in Social Science, 1968
- (5) Atkinson, R.C., and Wilson, H.A. (eds), Computer-Assisted Instruction - A Book of Readings, Academic Press, 1969
- (6) Hooper, R., and Toye, I. (eds), Computer Assisted Learning in the United Kingdom - Some Case Studies, Council for Educational Technology, National Development Programme in Computer Assisted Learning, 1975
- (7) Hooper, R., The National Development Programme in Computer Assisted Learning - Final Report of the Director, Council for Educational Technology, London, 1977
- (8) Holland, W.B. and Hawkins, M.L., Technology of Computer Uses in Instruction, in Levien, R.E. (ed), The Emerging Technology: Instructional Uses of the Computer in Higher Education, McGraw-Hill, New York, 1972
- (9) Zinn, K.L., Programming Conversational Use of Computers for Instruction, in Atkinson, R.C. and Wilson, H.A. (eds), Computer Assisted Instruction - A Book of Readings, Academic Press, 1969
- (10) Grubb, R.E., Learner Controlled Statistics, in Atkinson, R.C. and Wilson, H.A. (eds), Computer Assisted Instruction - A Book of Readings, Academic Press, 1969

CHAPTER 4

DEVELOPMENT OF AN INTEGRATED APPROACH TO CAL

- 4.1 Introduction
- 4.2 The Diversity of Current CAL Projects
- 4.3 The PLATO System - System Overview
 - 4.31 The PLATO Terminal
 - 4.32 PLATO Courseware
- 4.4 The TICCIT System
 - 4.41 The TICCIT Method of Instruction
- 4.5 The CYCLOPS System
 - 4.51 The CYCLOPS Recording System
 - 4.52 Production of Graphics by CYCLOPS
 - 4.53 Animation Speed of CYCLOPS
 - 4.54 Play-back Procedure
 - 4.55 Cost Advantages
 - 4.56 Comparison of CYCLOPS with other Audio-Visual Systems
 - 4.57 Some Disadvantages of CYCLOPS
 - 4.58 Future Developments of CYCLOPS
- 4.6 Comparison of PLATO, TICCIT and CYCLOPS
 - 4.61 Similarities
 - 4.62 Differences
 - 4.63 Unique Features
 - 4.64 Summary
- 4.7 Micro-Multi-Media CAL
 - 4.71 Developments in the USA
 - 4.72 'AIDE' - A Micro-Multi-Media CAL Application
 - 4.73 Developments in Europe

CHAPTER 4

DEVELOPMENT OF AN INTEGRATED APPROACH TO CAL

4.1 INTRODUCTION

At the outset, early efforts at CAL were often those of isolated individuals and groups of people from within a single subject discipline. Unfortunately, these attempts at CAL were hampered by programming difficulties posed by early computers. The problems associated with using business oriented computers, unnatural programming languages and equipment that was not specifically designed for educational use caused many CAL pioneers to abandon their initial efforts. Some, however, did manage to produce instructional programs that were accessible to small groups of students.

During the decade of the 60's, CAL was characterised by a number of limiting factors:

1. Insufficiently powerful computers and inappropriate terminals
2. The distribution of limited resources over too many projects
3. Restriction of courseware design to a few rigid teaching strategies

In the 1970's, CAL underwent a remarkable change. This was mostly due to two large scale projects which differed in significant respects from earlier approaches. Their objective was to develop an integrated multi-media approach to CAL.

These developments started in 1960 when the National Science Foundation of the USA funded a major CAL programme called PLATO. The project was the first to attempt large scale usage

of computers for instructional purposes.

During the early 1970's, Bunderson (Chapter 3, Ref. 3) at the University of Texas at Austin developed a teaching strategy using a high level language between computer and student. The strategy embodied the concept of learner control used earlier by Grubb (Chapter 3, Ref. 9). At about the same time, the MITRE Corporation in the USA was developing an interactive cable television system which they began testing in the community of Reston, Virginia.

In 1972, the National Science Foundation of the USA funded the TICCIT program (Time-shared Interactive Computer Controlled Information Television). The MITRE Corporation was named as the Director of the programme and given the responsibility for the development of a CAL delivery system.

Both of these projects utilised hardware which was significantly better than that which was available in the 1960's, particularly the terminals which will be described later.

4.2 THE DIVERSITY OF CURRENT CAL PROJECTS

There was widespread agreement in the early 70's that CAL had to undergo some major changes in order to succeed. There was also considerable diversity of opinion about what changes should be made or which were most urgent.

Nievergelt (1975, Ref. 1) presents the following summary of opinions held by CAL workers of different backgrounds:

- (1) Administrators: consolidate CAL research in a few large projects, develop portable CAL systems
- (2) Educational experimentors: drop traditional CAL, teach the use of computers as problem solving tools

- (3) Educational theoreticians: drop teaching strategies which use strong program control, emphasise learner control
- (4) Engineers: develop better hardware, in particular terminals
- (5) Programmers: drop use of traditional programming languages, use or develop author languages that are close to general-purpose high-level programming languages

All of the above views were represented in the wide spectrum of CAL projects. The fact that opinions differed on the most suitable hardware configuration was less significant than the common recognition that insufficient hardware was one of the drawbacks of early CAL.

PLATO and TICCIT described below differ completely, not only in their hardware configurations but also in their philosophies towards the preparation of instructional material.

4.3 THE PLATO SYSTEM - SYSTEM OVERVIEW

According to a recent summary of current trends in CAL by Chambers and Sprecher (1980, Ref. 4), the PLATO system is undoubtedly the world's largest interactive computer-based education system.

This system is built around a number of component subsystems:

- (1) A large central computer (Control Data Cyber 70 Series) serving up to 1000 student consoles. Unlike other multi-terminal interactive systems, the PLATO system does not use drum or disk for short term mass storage. Instead it uses what Control Data Corporation call 'extended core storage' which has a transfer time 100 times greater and an access time 1000 times shorter than the conventional disk and drum storage. However, PLATO lessons are stored for the long term on large disks.

- (2) A high level author and user language called TUTOR. This language was originated by Tenczar at the Computer-based Educational Research Laboratory (CERL) in 1967 at the University of Illinois. From 1967 until the present time Control Data Corporation and CERL have engaged in a joint development effort and the present system is PLATO IV. From this has evolved the Control Data author language which supports the production of PLATO lessons. Any student terminal can be used by authors or teachers to write, edit and modify instructional materials. It also makes possible the acquisition, storage and manipulation of student performance data.

- (3) A sophisticated multi-media terminal provides interaction between users and the computer and is capable of displays, animation and selective erasure (erasing part of a display without affecting the remainder).

The terminal consists of a touch sensitive display screen, a keyboard, a microprocessor and associated electronics. Optional features include a random-access microfiche image selector, an audio unit and a hard copy device. These are described in detail below.

- (4) New communication techniques that make possible a geographically distributed computer-based network. This network also includes features that permit communication between persons at any preselected terminal. Messages of interest to users may be stored in the system (soft copy) or transferred to special consoles (hard copy).

4.31 The PLATO Terminal

Lessons can use the features described in Section 4.3 in any combination. During a music lesson, for example, notes can be displayed on the screen. The notes could also be produced on an attached audio device and the student asked to respond to a question by touching the screen.

Because of the unique nature of the PLATO terminal the various components, that is the screen, the keyboard, the touch panel and the optional devices, are described below. Cross references to Vol. II of this thesis, which includes illustrations of PLATO terminals in the form of 35mm. slides, are also included.

4.311 The Screen

The screen presents information as text or as line drawings. It is a high-resolution cathode-ray tube with a viewing area of 22cms x 22cms on the front of the terminal. The screen consists of a grid of 512 dots by 512 dots, which may be illuminated in any combination to form characters, lines, curves and figures. The computer can fit 32 lines of alphanumeric characters on the screen with 64 characters per line.

When the user presses a character key on the keyboard, the computer processes the individual keypress and displays an appropriate character on the user's screen, as determined by the current lesson. The terminal writes 170 characters per second and erases 600 characters per second, or the terminal can erase the whole screen at once. The terminal also draws and erases lines at speeds up to 60 lines per second.

General and close-up views of the PLATO screen are illustrated by slides Nos. 43 and 44 in Vol. II.

4.312 The Keyboard

The primary means of input to the PLATO system is the PLATO keyboard. This has character keys, much like a typewriter, and function keys, some of which affect lesson execution and some of which modify the character keys. For example, the student can often receive help in a lesson by using the HELP key, or a mathematics student can type numbers with exponents by using the SUPER (superscripts) key.

By using the SHIFT key, uppercase characters and

uppercase function keys become available. Because the keyboard is redefinable, the author of a lesson can also design alternate characters to use in a lesson. Some of the standard display functions available in the author language are:

- (1) Position displays (text or graphic) using grid coordinates
- (2) Display one or more lines of text
- (3) Display one of a list of text items on the basis of some condition
- (4) Change size and angle of text
- (5) Construct line drawn figures
- (6) Construct full circles, partial circles, and/or dashed circles
- (7) Construct figures that can be sized, rotated and positioned anywhere on the screen
- (8) Specify bounds outside of which line drawn displays are not presented
- (9) Erase or rewrite specified parts of displays
- (10) Display contents of lesson variables (numeric and/or alphabetic)
- (11) Display alternate characters
- (12) Control timing of display presentation
- (13) Construct graphs and charts
- (14) Create animated sequences

• 4.313 The Touch Panel

In addition to using the keyboard, users can enter information into the computer with the touch panel. The touch panel is a transparent plastic film on the cathode-ray tube, containing a 16 x 16 grid of infra-red sensors/detectors, which defines 256 touch sensitive areas. When a lesson activates the touch panel, the user can respond to a question by touching a particular area of the screen instead of typing the answer on the keyboard. The touch panel detects the location, sends that information to the computer, and sounds a tone to acknowledge the touch. Illustrations of the use of the

PLATO touch panel are presented in Slides Nos. 44 and 45, Vol. II.

4.314 PLATO System - Optional Devices

The terminal has auxiliary connectors for attaching external equipment such as hardcopy terminals, a random-access audio device, a music synthesiser, and laboratory and research equipment. Brief descriptions of these devices are given below.

4.315 The Microfiche Projector

The microfiche projector rear-projects colour slides on the screen, superimposing the slides on computer-generated text or line drawings. The microfiche is a sheet of film which stores the equivalent of 256 colour slides. Students or teachers insert the appropriate microfiche into the terminal to study a particular lesson. The projector can access each image on the microfiche in less than 0.4 second.

The microfiche projector is used with the 'plasma' version of the PLATO terminal described by Bitzer (Chapter 1 Ref. 12). Slide No. 46, Vol. II shows a lesson using a projected image (reproduced in black and white) on the top half of the screen, together with computer-generated multiple choice questions on the bottom half of the screen.

4.316 Hardcopy Devices

Two types of hardcopy device are available for attaching to the terminal. The first type, a video hardcopy unit, copies the video image from the screen on to paper. This device reproduces exactly all the text and drawings contained on the screen. The second type, an alphanumeric printer, is limited to printing alphanumeric characters but is particularly useful where documents of high quality text output are required.

4.317 Random-Access Audio Device

Under lesson control, the random-access audio device plays appropriate speech or music during a lesson. Students or teachers insert a disk into the audio device connected to the terminal. This stores about 22 minutes of speech, music or other sounds. Speech or music as short as 0.34 second or as long as 40 seconds can be accessed in 0.6 second.

4.318 Music Synthesiser

A music synthesiser consisting of an electronic waveform generator, an amplifier and loudspeakers is available. With special instructions an author or a student can use the system to compose music and then play it back with the music synthesiser under control of the terminal user.

4.319 Laboratory and Research Devices

A wide range of electronic devices can be attached to the terminal. Such facilities enable technicians to be trained in the use of various types of equipment. Thus, a maintenance electrician can learn to use test equipment by means of a PLATO simulation. For example, to provide experience in fault finding, the lesson would simulate malfunctions with a logic rack and oscilloscope attached to the terminal. During student interaction with the lesson the oscilloscope is actually under PLATO control.

4.32 **PLATO Courseware**

The spectrum of instructional material on PLATO terminals ranges from training airline pilots using simulation techniques to teaching very young children how to construct simple English language sentences (with graphics animations for rewards!). Barker (1979, Chapter 1 Ref. 11) lists some of the wide range of PLATO courseware now available in over 70 subjects from Accountancy to Veterinary Medicine, and draws attention to the fact that the teacher prepares the major part of his courseware sitting at the same type of computer terminal that the students use to learn from.

A system like PLATO is able to reduce the problems of finding the right materials for a teaching session because vast numbers of recorded examples, slides, audio and visual displays can be stored and randomly accessed rapidly by the computer.

The courseware provides instructional material for a large number of students. At a conference in 1975 reference was made to PLATO usage by Alpert (Ref. 2) who stated that in the USA (at that time, 2000 authors and 11000 students were using the system.

In 1980, Chambers and Sprecher (Ref. 4) forecast heavy future usage of the system. Major PLATO systems have been installed at the Universities of Delaware and Florida, emphasising support for music education. High schools in Florida are also using the system for remedial studies in mathematics.

In the UK, PLATO has been experimentally used by only a few large organisations, for example, the Royal Navy, International Computers Limited and International Telephone and Telegraph Limited, and this is undoubtedly due to the present high costs of renting terminals (about £1000 per terminal per month).

At the conference previously referred to, Alpert expressed the opinion that PLATO costs were too high for widespread use by educational institutions. He suggested that if costs could be reduced by a factor of two or three, then many schools might readily invest in access to the system.

Thus, in economic terms, the PLATO system is faced with a cost-effectiveness problem. Wider use of the system depends upon lower component costs, and lower costs depend upon an expanded market for the system.

The relatively high cost of the student terminal is associated with manufacture in pilot-production rather than mass-production quantities. The general downward trend in computer processor costs may be expected to continue and reductions in terminal costs are likely to be achieved through redesign, using integrated circuitry and modern microprocessing techniques. In November

1979, Control Data Corporation announced a £5 million UK investment in PLATO involving the installation of the first three PLATO 'learning centres' during 1980 in London, Manchester and Birmingham (Ref. 3).

4.4 THE TICCIT SYSTEM

Bunderson's group at Brigham Young University developed the courseware for this system according to Morrison (1975, Ref. 5).

It consisted of lessons in English composition and mathematics. The colleges selected early in 1973 for participation in the experiment were Phoenix College, Arizona, USA, and Community College in Virginia, USA. About 4000 students were enrolled initially to use this courseware.

Up to 128 terminals can be connected to the TICCIT system. Students obtain all instructional material, including practice items and tests from the terminals which are connected to two Data General Nova 800 Series minicomputers. Each terminal consists of a high resolution colour TV receiver and a keyboard. This keyboard incorporates a set of 'learner control' keys (described below) as well as a standard typewriter keyboard.

4.41 The TICCIT Method of Instruction

Instruction proceeds at a pace controlled by each individual student. Course material is accessed by the student as required by him in the form of 'OBJECTIVE', 'RULE' ('easy RULE' and 'hard RULE' are available), 'HELP' (to explain the 'RULE' further), 'EXAMPLES' ('easy', 'medium' and 'hard' versions), and 'PRACTICE' items. The items may be accessed in any order and may be repeated at will. When the student feels he has mastered the material requested, he may ask for a TEST. The computer grades the test and informs the student of the result. If the student fails the mastery test, advice is given as to the material that he must review before he takes the test again.

4.5 CYCLOPS

CYCLOPS is an audio-visual system being developed by the Open University in the United Kingdom. This system, like TICCIT, also combines computer and television technology.

Development of the system started in 1976 under the direction of Graham Read (Chapter 1 Ref. 13) and by 1978 there was collaboration with Birmingham University to set up an experimental facility on the Birmingham campus.

This system is unique in that it is compatible with UK broadcast teletext systems such as CEEFAX and ORACLE, and viewdata interactive systems such as PRESTEL.

Because of the unique features of its multi-media approach to computer-based instruction, this section will review the significant facilities of CYCLOPS and will include cross-references to Vol. II, which include illustrations of some of these innovative features which offer great potential for low cost CAL.

4.51 The CYCLOPS Recording System

The basic CYCLOPS system allows the student to play audio-visual tapes. A sound commentary is recorded on the left hand channel of a stereo tape. The corresponding graphical material is produced from a computer program and stored in a large computer situated at the Open University. Sequences of graphical images produced by the program are subsequently transferred to the cassette tape. In the final stage of the recording, the sound on the left hand channel is synchronised with the visual information recorded on the right hand channel. The result is a stereo tape carrying an audio signal on one channel and a digital visual signal on the other.

Slide No. 48 illustrating the basic CYCLOPS system is included in Vol. II.

4.52 **Production of Graphics by CYCLOPS**

The screen of the television set contains a 256 x 256 matrix of squares which can either be switched on or off, so that the pictures are composed of 2^{16} small black or white squares.

Graphics are compiled in four ways. In the first, characters from a normal ASCII keyboard are typed on to a computer file, before being fed to the screen (which is able to contain a grid of 40 x 24 characters).

In the second method, a prepared graphic is placed in front of a conventional TV camera. The picture is then formed into small squares and fed to the computer store. Some examples of original and processed graphics are shown in slide No. 50, Vol. II. The figures on the left represent the prepared graphics, and those on the right are as they would actually appear on the TV screen in digital form.

The third method uses S-BASIC, which is a simple graphics language enabling the user to encode any image which can be specified by a formula, for example, a sine curve or a circle. An example of this method is illustrated in slide No. 49.

The fourth method involves the use of an electronic digitising tablet.

4.53 **Animation Speed of CYCLOPS**

The total TV screen can be refreshed in about 75 seconds, but, with suitable software in the computer, a picture which occupies a small number of squares can be reproduced very much more rapidly. An individual character can be printed in 1/120th of a second.

Current developments are aimed at ensuring that small areas of the screen can be updated at something approaching normal film speed.

4.54 **Play-back Procedure**

CYCLOPS contains its own cassette deck and is similar in size to a conventional cassette recorder. This is illustrated in slide No. 49 which shows the device on the top of a TV set. The output is fed along a coaxial cable to the aerial socket of the TV set, and the sound from the left hand channel of the cassette emerges from the loudspeaker of the TV receiver.

If at any time the tape is stopped, the picture is continuously updated from the microcomputer store and stays on the screen. The pace of the tape can, therefore, be controlled by the student. The presenter could, for example, ask the student some questions and then tell him to switch off the tape before receiving the answers.

4.55 **Cost Advantages**

The CYCLOPS system is based on existing technology, that is, a standard television set and standard cassettes, and this gives several advantages:

- (1) Users are expected to have access to a television set and so it is unnecessary to buy this equipment.
- (2) The cassettes are standard so there are no special production costs.
- (3) The maintenance of the equipment is not likely to cause problems since it is composed either of solid state hardware, which is largely trouble free, or standard equipment, which can be maintained by any competent technician without special training.
- (4) The standard technology is also 'low level' and users are expected to cope with the minor difficulties which all cassette players are occasionally subject to.
- (5) The cost of the tapes is a great deal lower than that of a standard video tape. At current prices audio tapes are only

1/20th of the cost of video tapes. For an installation that requires a large number of tapes, for example, a language laboratory, the cost advantages would be considerable.

- (6) The cost of the microcomputer is difficult to determine since it depends upon the numbers produced. However, the cost has been projected by Read (Chapter 1 Ref. 13) to be about the same as a programmable calculator or the control box for television games.

From the above it will be seen that compared with PLATO hardware, the system is relatively low-cost.

4.56 Comparison of CYCLOPS with other Audio-Visual Systems

The ease of storage and the capacity for producing animated pictures gives the system advantages over tape/slide and video. It will enable a user to use TV in order to access a large computer via a telephone line as illustrated in Slide No. 51. It is possible to communicate visually with a light pen (slide No. 49). The system is also compatible with UK teletext systems which can be used for entertainment or education.

4.57 Some Disadvantages of CYCLOPS

Current disadvantages of the system are:

- (1) The picture is composed of 256 x 256 dots and the definition is below that of conventional TV
- (2) The microcomputer store cannot cope with true moving pictures although some slow animation is currently possible
- (3) The picture is black and white
- (4) Limited courseware (compared with PLATO)
- (5) Limited authoring facilities

All the above disadvantages could be overcome by increasing the size of the microcomputer store, with a consequent increase in unit cost, and by the use of more sophisticated software. As the cost of storage is falling very rapidly, it is anticipated that future developments of the CYCLOPS system will overcome these difficulties.

Surprisingly, the reduction of the picture to a 256 x 256 array of dots produces good quality illustrations - see slide No. 50.

4.58 **Future Developments of CYCLOPS**

CYCLOPS has been designed specifically to be a cost-effective audio-visual replay system, that is, the cheapest and most efficient system which the Open University team could produce which maintained the quality of picture and sound necessary for the most likely applications. Their problem in making improvements to the speed and quality of the picture is not to determine how it could be done but how it is to be done with minimal cost.

The current philosophy of the Open University is to consolidate the present system which works adequately and develop it as a working device while continuing with research with the prospect of a more refined system becoming available in the near future. The Open University is in a unique position to exploit the CYCLOPS system and to develop it into an economically and educationally successful system as they not only already have a large potential market and the need for such a system but also have the computer, audio-visual resources and educationalists to produce the vast amount of courseware which will be needed.

4.6 **COMPARISON OF PLATO, TICCIT AND CYCLOPS**

4.61 **Similarities**

All three systems have basic similarities. They have the same overall educational objective. This is to provide computer-based

interactive learning systems. Television technology is used by all the systems to enhance the process of communication. In the PLATO system a TV channel is used to permit large amounts of information to be rapidly transferred to the user's terminal. This terminal does not, however, incorporate a conventional domestic TV receiver as in the case of TICCIT and CYCLOPS. A further common feature is the adoption of an integrated multi-media approach to CAL by all the systems.

4.62 Differences

PLATO and TICCIT have both been operational for several years and evaluations have been carried out on both systems - see Chambers and Sprecher (1980, Ref. 4). The CYCLOPS system is still in the research and experimentation stage. Courseware for this project is still under development.

The approach to courseware in the TICCIT system is different from that adopted by the PLATO system. Courseware development for TICCIT began in January 1973, and this system accomplished what no other CAL system has done to date. First, course content and computer programming have been completely separated. Authors need not learn computer programming. Second, course content and teaching strategy have also been separated. The strategy developed by Bunderson et al is independent of the subject matter. This allows the strategy to be incorporated into a computer program operating system written by programming experts. However, to date TICCIT courseware has been limited to English and Mathematics courses. This is in contrast to the PLATO system which has courseware covering a very wide range of disciplines. The TICCIT system also has a uniform style of courseware based on the theory of instruction developed by Bunderson in 1972.

In contrast, PLATO does not require specific educational strategies or formats. Instead it strives to maximise for each category of user the accessibility of the features most needed for their specific tasks. As a result of this philosophy, PLATO can deal with many more subjects than is possible at present with the

TICCIT system. Another major difference between the systems is that while courseware for PLATO and CYCLOPS is developed on large main frame computers, TICCIT uses minicomputers. While reducing costs, this has demanded an efficiency in operating systems not required in larger systems. The effort required for software development was grossly underestimated for the TICCIT system - see Morrison (1975, Ref. 5).

4.63 Unique Features

A unique feature of the PLATO system is the plasma screen. This technology is not used by either TICCIT or CYCLOPS. Their screens are not touch sensitive. CYCLOPS does, however, permit interaction with a light pen device. Neither PLATO nor TICCIT are compatible with teletext systems. CYCLOPS is compatible with the United Kingdom broadcast teletext systems and the British Post Office interactive system, PRESTEL. The CYCLOPS system is based on a standard television set and standard cassettes. Both PLATO and TICCIT need to use specialised equipment. However, PLATO has a number of unique features which are not available on the other two systems. First, it is capable of rear projection of microfiche which allows random access of up to 256 colour slides. Second, its music synthesiser is a unique feature not possessed by the other systems. Finally, laboratory and research equipment can be connected to PLATO for use in a simulation mode.

4.64 Summary

Currently there appears to be two developments in opposite directions. First, there is the existence of large operational CAL systems. Systems such as PLATO and IBM's Interactive Instructional System (IIS) (IBM 1980, Ref. 6) have hundreds of terminals served by the computer. One advantage of this approach to CAL is that the lesson is easily exchangeable. A disadvantage is the technical and organisational dependence on one central machine, in which all data of students, teachers and lessons are stored. Another disadvantage is the high cost in a period of economic constraints.

An entirely different trend is the development of very small and cheap computers which can locally present lessons via terminals. These microcomputers now have multi-media capabilities. This is discussed below.

4.7 MICRO-MULTI-MEDIA CAL

4.71 Developments in the USA

Some of the major implications of microelectronics for modern society are associated with the rapid development of new technologies for communication and computation. These will have a profound effect on the way in which information is stored, transmitted and received. One of the most important results for education is the decreasing cost and size of the computer. The role of the microcomputer as a system component is increasing substantially. This is due mainly to its high response characteristics, reliability, portability and availability. Addition of local storage peripherals (flexible disks, tape cassettes) are commonplace articles. The interface between the microcomputer and other more unusual peripherals is a more recently documented occurrence.

A microcomputer-based CAL system called 'AIDE' which has many unique features is currently being developed by Towne (1979, Ref. 7) at the University of Southern California, Los Angeles.

'AIDE' is an acronym for Automated Instruction, Direction and Exercise. As this system offers a range of instructional potential which, until recently, was available only from the larger type of system previously described, its main features are outlined below.

NOTE: In this discussion the term 'target equipment' is used to refer to the equipment to which the instructional material is devoted as contrasted to the actual equipment used to implement the system.

4.72 'AIDE' - A Micro-Multi-Media CAL Application

AIDE is being developed under a contract with the US Naval Equipment Training Centre.

The Behavioural Technology Laboratories of the University of Southern California has assembled the hardware elements of the system to develop a computer controlled trainer/simulator/job support system. One of the objectives of this venture is to use commercially available microcomputer hardware. This supports a multi-media data base system that is used to characterise a specific piece of target equipment (a radar repeater). Finally, programmed routines for educating/ training novice operator/technicians and aiding target equipment operation and maintenance have been developed. Some of the basic features of this system are outlined below.

4.721 AIDE Hardware Elements

The major hardware elements of AIDE are as follows:

- 1) A microcomputer (Zilog Z80) with a microprocessor 8 bit CPU and 32K bytes of random accessed memory.
- 2) Flexible disk storage with a capacity of 300K bytes.
- 3) A 9" diagonal CRT which gives an alphanumeric display of 16 lines with 64 characters per line.
- 4) A micrographics unit (Bruning 95 Microfiche). This has a capacity of 30 microfiche each containing 60 images/fiche. The unit can display colour photographs under computer control. These can be 35mm colour slides or colour microfiche from which the slides can be randomly accessed.
- 5) A sonic touch pen for user inputs.
- 6) A small hard copy printer.
- 7) A voice synthesising device.

A 'command menu' is positioned below the CRT. This is a removeable card labelled with the commands to which AIDE will respond when touched by the sonic pen. These allow the user to:

- a) Select modes of instruction (assistance, instruction, drill).
- b) Obtain any available information about the purpose, theory of operation, or location of any section of the target equipment for which the technician is being trained.
- c) View either a photograph or functional diagram of a section of the target equipment.

The majority of user inputs and responses are made by touching the sonic pen to individual items listed on the CRT, or to particular portions of the hardware displayed on the micrographic screen.

As described below, this allows the technician to, in effect, operate, disassemble, and interrogate the simulated target equipment, and to interact with AIDE regarding the instructional material that he requires.

4.722 Capabilities of the AIDE System

The three basic modes of operation provided are:

1. Job assistance
2. Instruction
3. Drill and exercise

Each of these three modes is available in three general topics:

1. Equipment configuration
2. Equipment set-ups (operating and maintenance)
3. Fault-finding

The nine resulting types of student/AIDE interactions are produced from a single bank of information and graphic representations. Various routines are available which permit the following types of operation to be performed:

- 1) Present a picture of sub-element X
- 2) Present text which explains the purpose of X
- 3) Present a functional diagram of X
- 4) Present a picture which shows where X is located
- 5) Determine what part of X the user just touched with the pen
- 6) Display a listing of switch settings for mode M
- 7) Show the front panel indicators in mode M
- 8) Show indicator 1 reading normal

In these 'user requests', X denotes one of the components of the equipment with which the data base deals, while M denotes a mode of usage of that equipment.

The most fundamental topic addressed by AIDE is equipment configuration. It has the ability to a) locate and identify physical elements in the target equipment or system, and b) understand the functions of the elements from which it is constructed.

4.723 The AIDE Data Base

The objective of AIDE is to offer rich and detailed education and training. The data base must, therefore, be extensive. The current data base, developed just to test and demonstrate AIDE, contains great detail for just a few areas of an item of equipment called a radar repeater. The data base contains only a few of the possible equipment arrangements and offers faultfinding intelligence for only a small proportion of the equipment. The demonstration data base contains 125 images, approximately 50 of which were taken directly from existing technical manuals. It has been estimated that a complete, detailed AIDE data base for the radar repeater would involve approximately 1000 images. Of these, one

quarter would be taken directly from the technical manual, one half taken from the actual equipment, and one quarter taken from specially prepared diagrams and text.

4.724 Data Base Requirements

From the above it is apparent that a substantial volume of photographic work is involved, requiring, perhaps, several man-months of effort. For expensive operational systems this cost is acceptable compared to the cost of either using the actual system or a special purpose simulator for training purposes.

The author may expand the target equipment into any units which he feels are necessary and useful for understanding. AIDE requires him to provide both a physical breakdown and a functional breakdown of the target equipment, and a cross reference between the two.

In addition, the author must obtain photographs of each element of the physical hierarchy of components and a photograph of each diagram in the functional hierarchy. He must also provide pages of written explanations to describe the purpose and operation of those sub-elements he wishes to have included in the training programme. Photographs and diagrams are currently provided in the form of 35mm colour slides. Ultimately, it is the intention to convert these into colour microfiche.

The information supplied by the author is not designed specifically for assistance, instruction or drill. A monitor program handles all retrieval and presentation of the supplied material according to the requirements of the user.

Data base retrieval proceeds as follows: the author touches the pen to an appropriate sub-section of each photograph. This produces XY coordinates for use in the data base retrieval software. This procedure allows the user to search through either of the previously described hierarchies by touching the area of interest on the

currently projected image. Each time AIDE responds to a retrieval request it presents a close up image of the sub-section selected. On-the-job training and job performance assessment for equipment operation and maintenance is produced by supplying names of controls, setting names, mode names, mode descriptions (required control settings) and photographs of the panel(s) for each mode.

Fault-finding training is generated by AIDE from a fault-finding 'tree' which specifies a detailed, conditional, fault isolation approach produced by the author. Photographs of normal and abnormal symptoms for each involved indicator (including test equipment) and an explanatory text are added to assist in performing and interpreting tests.

4.725 Instructional Approach of AIDE: Summary

The instructional approach employed does not follow any single well-known technique. It has Socratic (dialogue) elements in the sense of responding to user initiated requests. It is also described as being heavily oriented towards a technique called 'web learning'. This type of learning (Norman, 1976, Ref. 8) initially provides a gross, fundamental structure of knowledge about a topic which is successively elaborated with increasing detail and wealth of information. For aiding performance the system functions primarily as an information retrieval system. It has the advantage that both data base structure and retrieval functions are consistent from one application to the next. They are not the responsibility of the author implementing a new subject equipment. This has been called a 'generative' approach by the designers of the system, Rigney and Towne (1974, Ref. 9). This allows the author to concentrate on describing the target system, without being required to also formulate student-computer dialogues and instructional schemas.

4.73 **Developments in Europe**

An extensive amount of work on the microcomputer/tapeslide interface and the microcomputer/videotape interface has been done by Kenny (1979, Ref. 10). In the applications that he has described, a tape/slide lecture is given under the control of a microcomputer. After a certain number of slides have been presented, the computer halts the slide presentation and asks the viewer questions on the material that he has seen. The responses to the questions are assessed by the computer and the student is then given appropriate feedback. In lectures requiring moving, as opposed to still pictures, a video cassette is used. Here, the microcomputer stops the cassette after a predetermined time and asks the student questions on the material that has been presented to him. Experiments to interface tape/slide equipment with a microcomputer have been undertaken as part of this research project. The microcomputer/tapeslide interface described by Kenny has been reproduced and has been found to work effectively. This and other experiments using a random-access slide projector interfaced with a microcomputer are described in Chapter 6.

In 1979 the French National Experiment took a major policy decision on microcomputers. The French Ministries of Education and Industry jointly launched a five-year plan to install 10,000 microcomputers within secondary schools for use with students between the ages of 11 and 18. This decision was greatly influenced by the results of the earlier experiment with computers in schools - see Habenstreit (1980, Ref. 11). However, how much of this equipment will become incorporated into multi-media CAL systems remains to be seen.

In the UK the first stage of the Government's £9 million Microelectronics Development Programme is due to start in September 1980. The programme is to spread over four years and will give priority to curriculum development in science, mathematics, technical and business studies. £1 million has been allocated to training teachers in the new technology and the use of microcomputers as a learning aid in schools. Again, there seems to be little emphasis on the use of multi-media approaches to the use of microcomputers.

REFERENCES

- (1) Nievergelt, J., Interactive Systems for Education - The New Look of CAI, Computers in Education, IFIP, 1975
- (2) Alpert, D., The PLATO IV System in Use: A Progress Report, Computers in Education, IFIP, 1975
- (3) Cane, A., PLATO Headed for UK, Computing Europe, 15 November 1979
- (4) Chambers, J.A. and Sprecher, J.W., Computer Assisted Instruction: Current Trends and Critical Issues, Communications of the ACM, June 1980, Vol.23, No.6
- (5) Morrison, F., Planning a Large Scale CAI Installation: The TICCIT Experience, Computers in Education, IFIP, 1975
- (6) IBM Guide for Application Programming: Computer Based Training at Barclaycard, GE15-6154, February 1980
- (7) Towne, D.M., The Automated Integration of Training and Aiding Information for the Operator/Technician, Behavioural Technology Laboratories, University of Southern California, Los Angeles, USA, 1979
- (8) Norman, O.A., Studies of Learning and Self-contained Educational Systems, 1973-1976 (Tech. Rep No.7601), University of California, San Diego Centre for Human Information Processing, March 1976
- (9) Rigney, J.W. and Town, D.M., Computer Aided Performance Training for Diagnostic and Procedural Tasks, J. Educational Technology Systems, Vol.2 (4), 1974
- (10) Kenny, G.N.C. and Schmulian, G., Computer Assisted Learning in the Teaching of Anaesthesia, Anaesthesia, Vol.34, 159-162, 1979
- (11) Habenstreit, J., 10,000 Microcomputers for French Secondary Schools, Computer, July 1980

CHAPTER 5

INDUSTRIAL AND COMMERCIAL APPLICATIONS OF CAL

- 5.1 Introduction
- 5.2 Training Problems in Industry and Commerce
- 5.3 CAL Applications in Industrial and Commercial Training
 - 5.31 Instructional Uses
 - 5.32 Non-Instructional Uses
 - 5.33 Integration of CAL with other Training Media
- 5.4 Factors influencing Decision to use CAL
 - 5.41 Quantitative Benefits
 - 5.42 Qualitative Benefits
 - 5.43 Relation of Costs and Benefits
- 5.5 CAL in a Training Environment
 - 5.51 Identification of CAL Training Situations
 - 5.52 Course Development Process
 - 5.53 Task Analysis
 - 5.54 Media Selection
 - 5.55 Example of a Typical CAL Lesson
- 5.6 Computing Environment
 - 5.61 In-House Mainframe
 - 5.62 Bureau Approach
 - 5.63 Mini and Microcomputers
 - 5.64 Publicly Available Computer Systems
- 5.7 Conclusion

CHAPTER 5

INDUSTRIAL AND COMMERCIAL APPLICATIONS OF CAL

5.1 INTRODUCTION

The work of the National Development Programme in Computer Assisted Learning (NDPCAL) was discussed in Chapter 3. CAL projects in the educational sector (universities, further education and schools) in the United Kingdom and elsewhere have been described. Many of the justifications for the NDPCAL projects apply equally well to industrial and commercial training environments.

Computer assisted training is an instructional technology that has been developed over the last decade, both in North America and the United Kingdom. It has derived much of its impetus from work with CAL in the academic environment. However, training organisations experience difficulties not usually encountered in educational establishments. This chapter discusses some of the problems associated with training in commercial and industrial organisations. The ways in which the computer has been integrated into the training environment to overcome these problems is described. Also included are some examples of current computer assisted training applications. A summary of CAL projects in a variety of commercial organisations is presented at the end of the chapter.

5.2 TRAINING PROBLEMS IN INDUSTRY AND COMMERCE

Many industries, for example, banking, retail distribution, airlines and telecommunications, are facing a rapidly rising demand for staff training facilities. This situation arises as a result of a number of factors:

1. The introduction of computer systems into an organisation usually requires the development of new methods and procedures. Consequently, staff will require familiarisation and training in order to become acquainted with the new facilities.
2. The introduction of new types of product (based upon modern technological advancements) requires a significant amount of employee retraining if they are to be used effectively.
3. There is generally a lack of relevantly qualified new employees entering the employment sector from the educational system.

Because of these factors, training organisations are searching for more effective approaches that will enable them to increase productivity. They are using new technologies and are adopting interactive self-study methods for training. While CAL has been in use in the educational sector for some time, there are some major differences between education and training needs. Organisations in commerce and industry often have a wide geographical distribution of trainees, high turnover rates (particularly of female staff), they need to employ large numbers of part-time staff and have fragmented recruitment. Consequently, the problems associated with training in commercial and industrial organisations include the need to:

1. Provide comprehensive training for new staff.
2. Offer refresher training for existing staff.
3. Minimise the time an employee spends away from the job (or from home) while being trained.
4. Supply only that training which is relevant to an employee's needs, and to make this available when it is required.
5. Prevent time being wasted while a student waits for a training course to be scheduled (due to fragmented recruitment).

6. Reduce the costs associated with training arising from
 - travel,
 - subsistence, and,
 - the cost of publishing training materials.

According to a survey carried out by Mills & Allen Communications Ltd. on behalf of the Manpower Services Commission (1978, Ref. 1), a growing number of organisations are overcoming these problems by integrating CAL techniques into their training programmes.

While specific examples of CAL applications are given later, the use of the computer for training covers two broad areas:

1. Instructional uses, and,
2. Non-Instructional uses.

These are described below.

5.3 CAL APPLICATIONS IN COMMERCIAL AND INDUSTRIAL TRAINING

5.31 Instructional Uses

The applications for the computer in commercial and industrial training are practically unlimited. For example, CAL can be used to:

1. provide orientation courses and test new employees in order to determine their individual training requirements,
2. provide a common background to a group of students before they enter a class,
3. teach computer terminal operators how to process their work through the terminal,
4. provide basic skill training to new employees prior to technical training,

5. present all or part of the instruction needed in such diverse areas as programming, office skills, computer concepts, administrative procedures and fault finding.

5.32 **Non-Instructional Uses**

In addition to the foregoing instructional uses, the computer is used in other applications such as:

1. maintaining training records (both CAL and non-CAL) of each employee,
2. providing performance certification testing,
3. recording employee survey or questionnaire answers,
4. testing to identify the general training needs of a given group to help the training organisation identify what new training must be developed.

5.33 **Integration of CAL with other Training Media**

In the organisations studied the adoption of CAL did not mean that existing training materials were discarded or even revised drastically. Instead, CAL was viewed as just one more training medium to be combined with other media as appropriate.

A typical CAL course structure would aim to use a CMI (Computer Managed Instruction) approach to tie together existing study materials. For example, suppose a programmed instruction (PI) text, and audio tape with associated booklet, and a lecture course already exist for a given subject. Using the CMI approach, a training programme could be developed along the lines shown in Figure 5.1.

In each case the results of the terminal test are used to determine what instruction each student should receive. Usually, the student skips the related instructional material after answering a pre-test question correctly. The final testing and instruction help to ensure that each student has the required prerequisites

SAMPLE CAL COURSE SEQUENCE - USING CMI TECHNIQUE

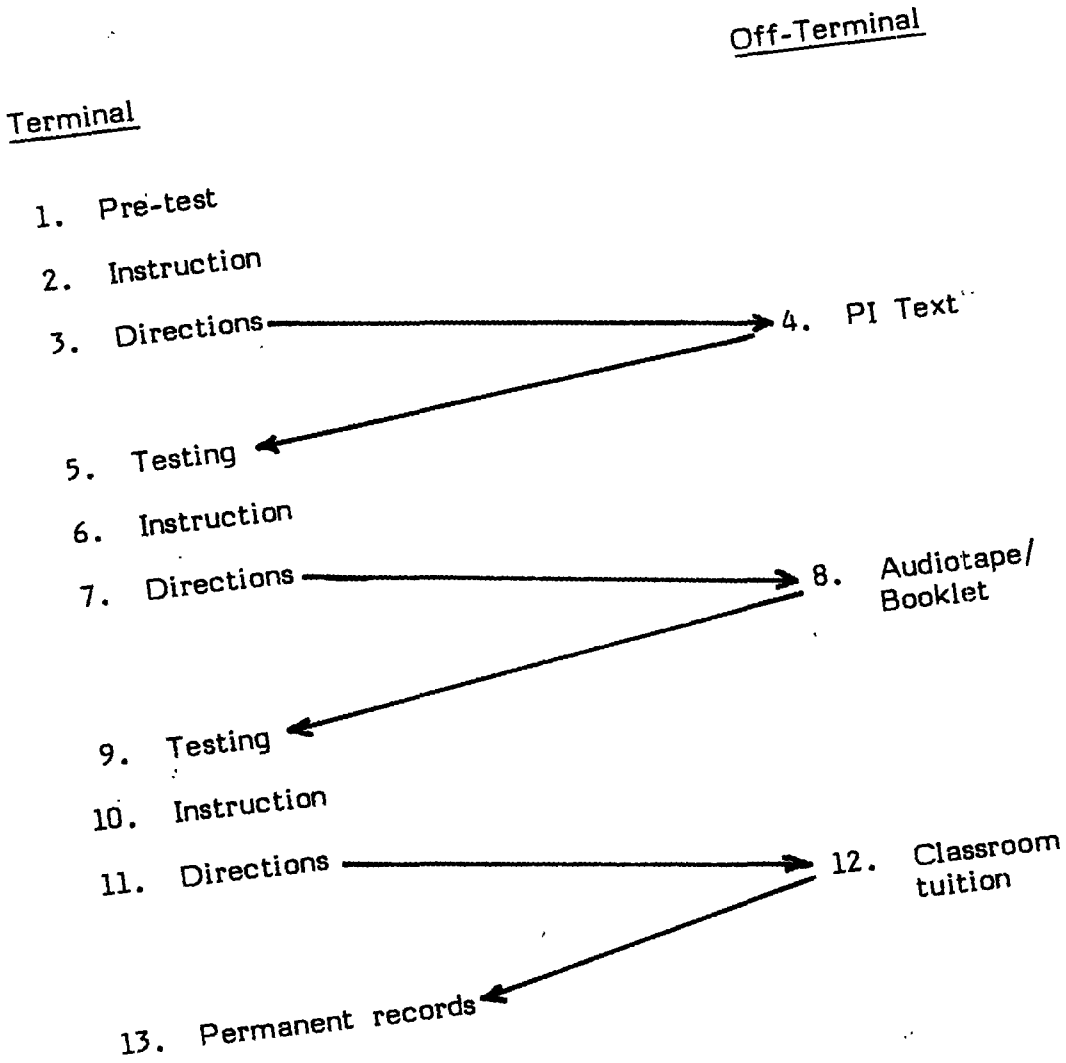

Figure 5.1

before attending the lecture course. In addition, CAL data can provide a permanent record of each student's performance and course completion.

This approach allows the continued use of already successful teaching materials, combined with the new administrative recording, individualisation and testing advantages offered by the use of a computer.

In industrial and commercial training, the 'system approach' to course development is followed. That is, training is regarded as part of the overall business planning cycle and integrated with the short and long term corporate objectives of the organisation. The training function must justify its training programmes in terms of costs and benefits to the organisation and each course must meet valid training objectives. Each training medium, CAL included, is not used indiscriminately but is selected only when its characteristics best meet the training needs.

5.4 FACTORS INFLUENCING DECISIONS TO USE CAL

The greatest potential for the use of the computer in training is its contribution to increasing the productivity of people. One of the characteristics that distinguishes training from education is the fact that training establishments are more concerned with cost-effectiveness. For example, removing a week from a trainee's course via improved organisation and methods yields a financial saving to the employer (trainee's salary plus the cost of the week's training). By contrast, in much formal education the time spans for courses are fixed in duration. Thus a major factor which influences a decision to use CAL has to do with benefits which can be quantified financially. Training organisations which are using CAL are also finding that cost savings, while important, are not the only benefits that can be obtained. Various qualitative benefits, such as improved performance and standardisation of procedures, have been attributed to CAL. A number of factors have influenced decisions

to involve computers in commercial and industrial training programmes. These will be discussed under the following headings:

1. Quantitative Benefits.
2. Qualitative Benefits.
3. Relation of Costs and Benefits.

5.41 **Quantitative Benefits**

CAL, by its very nature, tends to reduce the use of resources whose costs are increasing, for example, the expenditure on those providing instruction. On the other hand, it tends to increase the use of computer facilities, whose costs are declining. Financial benefits from using CAL are to be found in five areas:

1. Use of existing computing facilities at marginal cost.
2. Reduced costs of residential training.
3. Reduced costs of live instruction.
4. Savings on training equipment.
5. Savings on updating.

Some examples of cost savings under each of the above headings are given below.

5.411 Use of existing computing facilities at marginal cost

A dominant reason for adopting CAL given by two large banking groups was a thoroughly pragmatic one - the computers were already available. These large organisations had been using computers for many years. They had spread terminal networks across geographically dispersed branches (in the UK and worldwide) and saw the opportunity to exploit unused computing capacity at marginal cost. A large retail distribution organisation and an airline are also using CAL as part of a multi-media system of training.

5.412 Reduced Costs of Residential Training

Large organisations similar to that described above with widely dispersed branches and companies have achieved

significant reductions in the costs of residential training. Using CAL with telecommunication links permits the training to be taken to the trainee 'on-the-job'. This saves travelling and hotel accommodation costs for certain types of training. The need for residential and centralised training cannot be entirely eliminated by CAL. There are social objectives in some kinds of training, for example, supervisory skills training, which cannot be met by using computers.

5.413 Costs of Live Instruction

There are many ways in which the costs of live instruction might be reduced. One computer manufacturing company which uses CAL for engineer and operator training reported (Ref. 1) that the demand for training in the period 1979/83 from customers and staff could not be met by live instruction and that some form of automated teaching would need to be used.

In their report on a CAL experiment that they had conducted, the British Post Office suggested that course length could be significantly reduced by means of this technique (Ref. 16). This would mean a specific saving of instructional staff's time.

A number of companies are experiencing the growing problem of fragmented recruitment, that is, small numbers of trainees arriving at irregular intervals and requiring training. Formal instruction is often no longer financially possible in such cases. Companies using CAL have reduced costs by not having unproductive trainees waiting until there was sufficient of them to start a traditional class.

Other comments made by various companies (Ref. 1) were:

1. Trainers were supervising larger groups with ratios improving from 1:10 to 1:20.
2. CAL had saved the valuable working time of

other employees, who previously had to sit with the trainees.

Clearly, this is an area for potential savings. Behind all these comments from companies there is the commercial incentive to reduce labour costs by capital investment. Training departments are not exempt from the need to reduce costs and many organisations currently using CAL undoubtedly view it as a form of capital investment.

Based upon information gained by the author as a result of personal visits to several organisations and attendance at CAL conferences, there seems to be considerable evidence to suggest that:

1. claims that savings have been made on live instructors should be treated with caution,
2. when the costs of developing CAL are taken into consideration (typically 100 hours to produce one good hour of teaching material), staff savings on many projects may be overstated.

5.414 Training Equipment Costs

Much of commercial and industrial training concerns the learning of skills on specific types of equipment. The costs of this equipment are often an important item in the training budget. Computer simulations can reduce the requirement for training equipment and can also increase the amount of practice time. Simulations using computer terminals also have the advantage of being inherently more flexible. If there are changes in the equipment specification, these can be accommodated by changes in the software.

5.415 Updating Problems

The costs of updating training materials are becoming formidable. This is due to the increasing speed of technological changes. These bring in their wake changes

in products, systems and procedures. A banking organisation using CAL (Ref. 2) reported faster and cheaper updating of their training procedures. Banks have high alteration rates of standardised forms as new interest rates and changing legislation come into being. These alteration rates are now introduced at the training stage via CAL and existing trained staff can quickly review new formats on the terminal.

5.42 **Qualitative Benefits**

Cost savings, actual or potential, are a major but not sole reason why existing organisations have decided to use CAL. One of the largest CAL users - a banking organisation (Ref. 2) - stated that they had not carried out any detailed cost analysis. They gave as their reason that a rough estimate of CAL costs showed that they amounted to barely 1% of the total computer costs and therefore were not worth considering. In addition to cost factors, a number of other important reasons for adopting CAL techniques have been reported (Ref. 1):

1. Relevance to training task.
2. Improved performance.
3. Standardisation and control of quality.
4. Individualisation.

Some examples of each of the above are given below.

5.421 Relevance to Training Task

Most of the current applications of CAL in the UK are based on the need to train operators and clerks to use their organisation's computer system. A summary of the types of staff using CAL is given in Section 5.7.

During their training period, operators become familiar and feel comfortable with the technology with which they are working. This familiarity has been found to reduce hostility to computerisation. The computer is seen, literally, to be doing a 'clever' job. Consequently, the operator, clerk or fault-finder spends less time doing tasks

manually and more time with the machine, often the computer or microprocessor, which does the work. One banking organisation (Ref. 2) discovered that operators can suffer from screen fatigue after sitting for long periods at a VDU. A limit of three hours VDU training per day was set with other forms of instruction being interspersed to reduce fatigue.

5.422 Improved Performance

It is very difficult to evaluate claims that a particular training innovation such as CAL has improved performance. The survey made by Mills & Allen (Ref. 1) revealed that most organisations currently involved in CAL invest very little in controlled evaluation. Many companies involved in the survey reported error reduction, better on-the-job performance (as a result of more practice in a simulation mode) and a more standardised performance of staff. One banking organisation claimed that errors were reduced from 1 in 2 to 1 in 1200 for a particular information input task. However, this error reduction was not solely caused by better training methods. In this particular case evaluation of training caused changes to be made to the computer system with which the clerical staff worked.

5.423 Standardisation

The use of CAL in geographically distributed companies has helped to bring about greater standardisation in training, documentation and procedural techniques. In areas such as banking and insurance, standard procedures often need to be rigorously applied in all branch offices through the organisation. Similarly, the area of emergency skills training is one in which rigorous standards need to be applied. Unfortunately, in situations where complex tasks need to be performed (as in the petrochemical industries) the human instructor is often unable to retain the sequence of detailed instructions in his head. As has been reported by one oil refinery manager (Ref. 1), this is an area where CAL is often able to help.

5.424 Individualisation

In addition to any cost advantages arising from CAL there are many other benefits. Most of these are derived from the individualised approach to instruction that CAL provides. Thus, trainees can absorb material at their own pace and in their own time (thus avoiding the constraints imposed by rigid class schedules). Furthermore, many employees involved in retraining (particularly the more mature ones) are usually unwilling to make errors in public. Consequently many do not participate fully in formal classroom tuition. CAL offers facilities to overcome these problems.

5.43 **Relation of Costs and Benefits**

In general, a CAL course may cost more to develop than a similar course based upon the use of some other medium. The higher development times for CAL courses are related to the highly structured subject matter. In addition there is the need to anticipate possible student responses and provide logical and educationally sound replies. A prime advantage, however, is that the development cost is expended only once. Organisations using CAL claim savings in instructor time (for preparation and presentation) and reduced study time (for assimilation). They believe these advantages affect the development costs. Because CAL frees instructors to work on new course development, more training can be provided from the same group of resources.

5.5 **CAL IN A TRAINING ENVIRONMENT**

5.51 **Identification of CAL Training Situations**

The goal of any commercial training function is to provide the most effective training in the least time at minimal cost with the least amount of effort. CAL techniques have been found to be appropriate in the following training situations (IBM, 1975, Ref. 3):

- (1) Many total students.
- (2) Many simultaneous students.
- (3) Many student locations.
- (4) Varied student backgrounds.
- (5) High employee turnover.
- (6) New employees lack qualifications.
- (7) Training load uneven.
- (8) Lack of qualified instructors.
- (9) Instruction standardisation needed.
- (10) Must guarantee student completion.
- (11) Student records needed.
- (12) Employee testing needed.
- (13) Terminal operator training needed.
- (14) Course not needed immediately.
- (15) Long course life expected.
- (16) Job procedure change planned.
- (17) Many classes with ten or fewer students.

The above "checklist" provides some important factors that may be used to evaluate the potential need for the application of CAL. As more of the training characteristics of a course match those on the checklist, so the likelihood of CAL satisfying the requirements of the course should increase.

The type of environment where investment in CAL is likely to be successful should satisfy most of the following pre-conditions (Ref. 1):

- (a) A clear identification of the training needs that could be met by CAL.
- (b) A commitment to individualisation in training methods and some existing experience in the design of self-instructional materials.
- (c) A commitment to integration of CAL within a multi-media training approach.
- (d) A commitment to invest the necessary resources in CAL.

5.52 Course Development Process

Course design includes the following general steps:

- (1) Analysis of the training requirements.
- (2) Identification of detailed course objectives.
- (3) Development of the final test questions on the basis of the course objectives.
- (4) Organisation and preparation of the course plan.
- (5) Determination of the most appropriate medium.

These are summarised schematically in Figure 5.2. The basic course design steps outlined are appropriate for all the media listed at the bottom of the diagram.

In practice, the course may be designed by someone in the training group or by a subject matter expert who hands over the documentation to the training group. This person may or may not be the individual who will actually write the course material.

5.53 Task Analysis

This is a structured study of a job or activity in order to identify each of the basic tasks that the employee must do to perform it. The task analysis is a list of all job tasks, including:

- (1) Exact tasks performed
- (2) Skills required (speaking, mathematics, typing, terminal operation, etc.)
- (3) Equipment and materials utilised (reference manual, calculator, computer terminal, etc.)
- (4) Sequence of tasks
- (5) Frequency of tasks
- (6) Acceptable level of performance (error rate, speed, amount, etc.)
- (7) Any changes between old and new procedures (where procedures are being changed)
- (8) Relative importance of task to total job
- (9) Department(s), Division(s) involved
- (10) Quality of performance required

COURSE DEVELOPMENT PROCESS

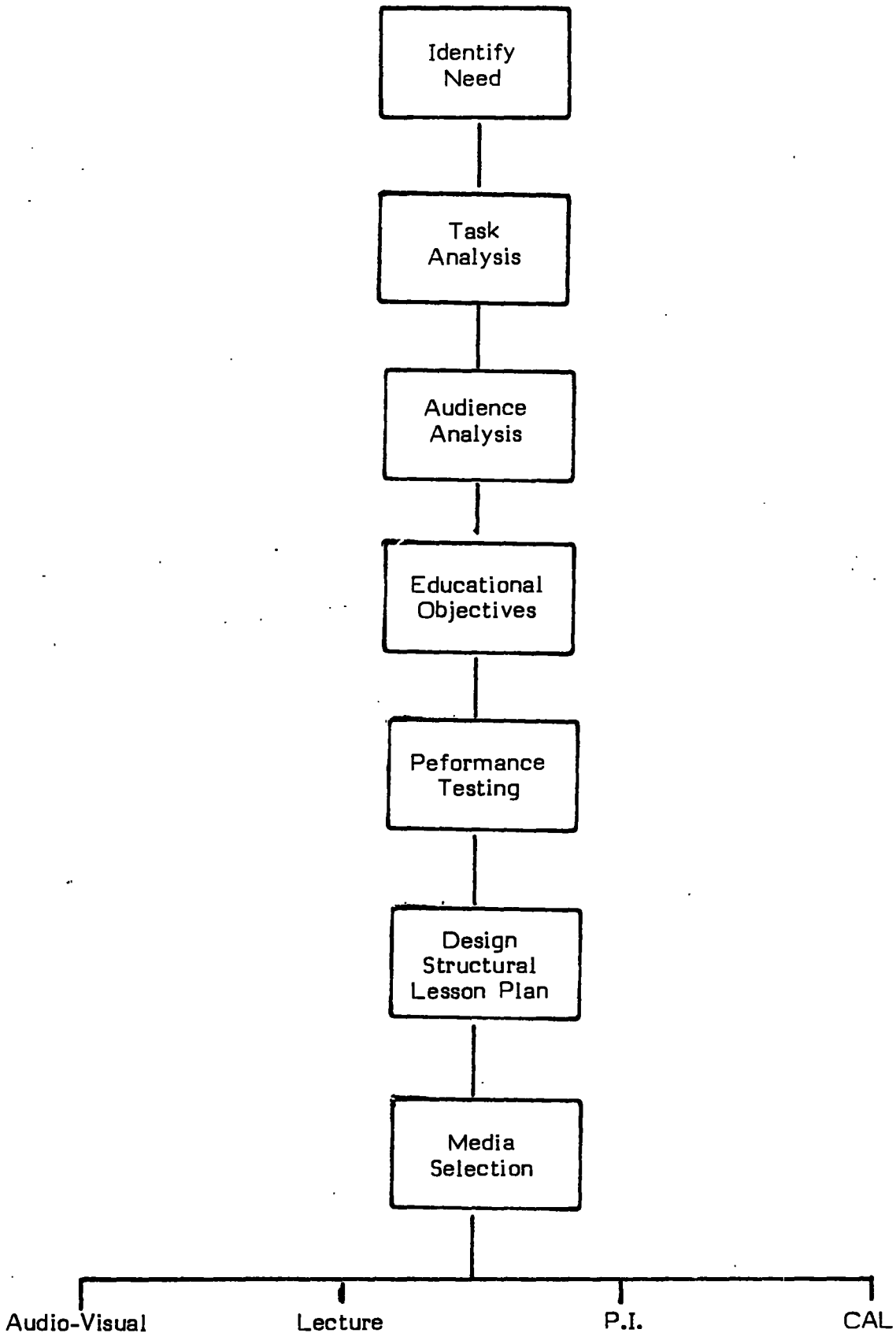

Figure 5.2

Each of the organisations studied in this research used the technique of task analysis. The amount of detail in the task analysis is determined by the complexity of the job, although even relatively simple jobs (for example, telephone answering technique) are, in practice, objectively analysed (Barclaycard, Ref. 2).

The wide range of tasks currently being taught by CAL is illustrated in the table presented in section 5.65.

5.54 **Media Selection**

Course material may be presented using a variety of media: on-the-job training, lectures, books and manuals, audio-visual materials, programmed instruction texts and CAL.

There is no single best medium for all courses and usually courses include more than one. Selection is determined by:

- (1) Overall characteristics of the training situation,
such as number of students, time for course development and the location of the students.
- (2) Course objectives
Bearing in mind the course objectives, the available media are evaluated in order to determine which is most appropriate. The advantages and limitations of each medium were discussed in Chapter 2.
- (3) Practical considerations,
such as availability of equipment, media development costs, availability of expertise and cost of maintaining materials and equipment.

Topics are reviewed by authors who then determine the best way to teach a particular topic by considering:

- (4) Content
The objectives and nature of the material are always prime considerations. For example, if the student needs to see an exact visual duplication of an item, a slide or photograph

would probably be used. Alternatively, if physical motion is essential for understanding a topic, a film or video tape might be employed.

(5) Availability of Materials

Course materials sometimes already exist and it makes sense to incorporate them provided that they meet the course objectives not just because they are available.

(6) Time available for Course Development

A lecture can be put together faster than a book, PI text or CAL course. However, combining existing materials with CAL may be faster than writing a new course.

(7) Equipment Availability

For example, audio-visual materials may require special equipment at each student location or at a central site.

(8) Length of Course

With a lengthy course, different techniques are desirable to maintain student interest. For example, a terminal pre-test can be followed by a short reading assignment, a tutorial CAL segment, an audio tape or a CAL drill and practice session. However, reading, the passive watching of films, or listening to audiotape are non-interactive techniques and are usually kept short.

(9) Stability of Course Material

Material presented through a computer terminal can be changed quickly and with a minimum of effort, whereas printed and audio-visual materials are more difficult and costly to change and distribute.

Both computer aided and computer managed instruction are used. Distinctions between these approaches to CAL are not, however, rigid and clearly there can be no 'correct' proportion of terminal to non-terminal material in a course because of the factors outlined in 1-9 above.

5.55 **Example of a typical CAL Lesson in Commercial Training**

A typical CAL lesson is usually structured in the following way:

(1) Introduction

To orientate the student to the lesson. It should state the objectives, outline the topics covered, identify supplementary materials required (so the student can make sure he has them) and give special instructions.

(2) Pre-test

To identify the topics in which the student needs to be instructed. It tests the student's ability to meet the objectives before he begins the lesson. He is then allowed to bypass material relating to the questions he answers correctly.

(3) Instructional Topics

To present instruction. Each topic may contain text, reference to off-terminal material, and questions and/or practice problems.

(4) Quiz or Post-test

To evaluate how much the student learnt from each topic. It may include the same questions as the pre-test, or it may be entirely different.

(5) Remedial Material

To provide additional instruction to students who do poorly on the post-test or on criterion questions within a topic.

(6) Summary

To summarise key points. This may be used for review while the student initially takes the course or later, if a 'refresher' is needed.

The author will need to decide whether supplementary materials are required. Although he will be responsible for their design, they may be developed by a "media expert". One banking organisation (Midland Bank, Ref. 4) has employed a TV specialist

to produce films, videotapes and other audio-visual materials which are integrated into the CAL lessons to create interest and variety and reduce VDU screen fatigue.

5.6 COMPUTING ENVIRONMENT

The diversity of actual and potential CAL applications more than matches the variety of business and industrial computing systems. Consequently, there can be no single optimum computing environment for CAL. Four different computing environments can be identified. Currently, three of these are in use for routine work, while the fourth listed below is being used experimentally.

1. In-House Mainframe.
2. Bureau Approach.
3. Mini and Microcomputers.
4. Publicly available computer systems.

5.61 In-House Mainframe

Large scale terminal-based transaction processing and enquiry systems have been operated for many years by airlines, banks and retail distribution organisations. Such organisations are obtaining the use of such systems at marginal cost as described earlier. Where large organisations are using more than one manufacturer's mainframe computer there is still an unmet need for a common author language. One large banking group (Midland, Ref. 4) refuses to be dependent upon a single computer manufacturer for its author language. The technical and organisational dependence on one central machine poses the question of whether or not centralisation of CAL is strictly necessary once materials have been developed.

5.62 Bureau Approach

A service called MENTOR (Ref. 5) has recently been launched by a Yorkshire-based computer bureau, PMSL Computer Services.

This type of service is very useful for those companies who wish to experiment with CAL prior to a full scale implementation. The MENTOR service is available throughout the UK via terminals and the public telephone network. The company is a subsidiary of the Provident Financial Group which has 500 branch offices and 50,000 retail outlets to redeem its credit cheques.

Group activities embrace banking, estate agencies, consumer credit and insurance. PMSL developed as a separate company from the expertise gained through implementing large ICL and Sperry Univac systems of CAL for the parent company which employs 4000 people. It is claimed that the MENTOR author language is easy to use. It requires only one day for a lesson writer to become competent (Ref. 5). In addition, the service offers a comprehensive registration and record keeping system and a graphics capability which is particularly useful. Software has been developed for the equipment which enables diagrams to be drawn directly on a tablet and stored away for use within lessons. These diagrams may be rotated and rescaled at the instructor's discretion. In order to use the graphics facilities, a special display terminal is needed. However, other instructional materials can be presented on a wide range of terminals, from low cost teletypes through to sophisticated minicomputers with high resolution graphics screens. When training is required on a particular terminal, some departments prefer to use their own equipment; this equipment is easily facilitated within the MENTOR system. This service therefore provides an extremely powerful and flexible training medium. The applications cover a broad spectrum from education to industry and commerce.

5.63 Mini and Microcomputers

There is scope for developing CAL materials to run on very small computers. These are easily transported about the company's premises and installed for personalised instruction at the place of work. Material requiring repeated presentation but only to one or two trainees on each occasion seems most suited to this approach. The Chemical and Allied Products Industry Training Board (Ref. 6) are using microcomputers costing less than £1000 each to provide fault-finding training to technicians.

A computer based training programme for major accident training is being developed at the Wessex Regional Health Authority (Ref. 7). This uses low cost microcomputers. This system runs a simulated disaster programme for multidisciplinary use within the Health Service. It provides variable emergency incidents and an assessment of performance. It can be used to check local emergency plans against the simulation. It can also be operated as a monitor while a disaster is actually in progress. The system can be used as a test or a tutor and provides participation and stimulation not available with other training media.

Over the last three years it has been realised that office skills, and particularly keyboard skills training, could be greatly assisted by the use of computers. For example, word processing is a major current development in office work emerging from microelectronics.

An organisation called Speedwriting/Speedtyping Ltd. has developed a minicomputer based training system for teaching these office skills. Speedwriting is a shorthand method based on the ordinary letters of the alphabet. It was developed in the 1920s by Emma Dearborn in response to demands for an easier shorthand system. The motivation for its development arose because many intelligent people were unable to master conventional symbol shorthands such as Pitman and Gregg. The speedwriting system that was developed was based on ordinary alphabetic letters and is now taught in most languages throughout the world. It is now a recognised office skill.

In a controlled experiment to investigate this technique, the Royal Air Force reported dramatic savings in learning time - see Edwards (1979, Ref. 8). They were able to reduce training time from 16 weeks to 8 weeks, improve average speeds from 80 words per minute to 100 words per minute, and their pass rate from 70% to 90%. The critical factor from the viewpoint of the RAF was time. A saving of eight weeks on a course represented a considerable amount of money.

Fundamentally, the CAL system developed helps the student in two areas; speed and accuracy. The students work at video terminals and are required to type exercises within certain time limits and error ranges. The exercise which the student attempts and an analysis of his performance are displayed on the screen. Depending upon his performance (and the criteria established by the author) the student would either be moved forward or, if unsuccessful, back for extra practice or other remedial action.

One of the reasons for the success of this CAL package is the simplicity of the author language which consists of only 12 easily understood commands. The simple commands and their uses are listed below:

<u>COMMAND</u>	<u>USE</u>
DISPLAY	Display a frame of information or instructions.
RETAIN	Add a second frame to the screen without removing the first.
SET	This command has a calculating function. The computer is told to convert its raw material, such as time taken to type a drill, into words per minute, or add the number of errors for a total error count.
READ	To alert the system that the student's work must be read and timed.
ANALYSE	Compares the student's work with the model copy of the exercise.
STORE	Commands the computer to record the results of the student's effort in its memory.

COUNT	This counts the number of attempts at an exercise which were needed by the student before the target results were achieved. This is used for evaluating progress and level of difficulty.
PREPARE	Insertion of student's results into a feedback frame.
INFORM	Inform the student of the above results.
GOTO	To move the student forward or backward in the course depending upon the results of his/her efforts.
CALL TUTOR	Alerts the Tutor to a particular student who is in need of assistance.
EXIT	When the student has finished the lesson with satisfactory results the computer moves on to the next lesson.

For every lesson there is a file of 'frames' and a file of Author commands. The student never sees the Author commands.

5.64 Publicly Available Computer Systems

PRESTEL, the British Post Office viewdata service (Chapter 1, Ref. 13) is the first generation of what could be termed public computer systems. These offer a potential computing environment for CAL. The modified television receiver was initially sold to the public as a means of playing TV games. However, this apparently trivial application is now being followed up by CAL programs designed for the same equipment. CAL involves the interactive possibilities of PRESTEL, which enables the student to make responses and those responses to be assessed. The results of the assessments can be instantaneously provided to reinforce understanding or to assist in self correction. The Post

Office Research Establishment at Martlesham Heath is currently experimenting with such a system which is not yet available to the general public. The index page in the section on experimental education programs (Fedida & Malik, 1979, Ref. 11) gives an indication of the possibilities of PRESTEL in computer based training:

- 0 An Experiment in Programmed Learning
- 1 Junior School Topics
- 2 Multiple Choice Questions
- 3 CAI under Task Control
- 4 Examination/Revision Notes
- 5 Graded Quizzes
- 6 Previous Examination Papers
- 7 Computer Aided Instruction
- 8 The Laboratory on the Screen
- 9 Decision Making in Medicine

Choice 3 provides an example of the possibilities. The student is presented with some instructional text on elementary thermodynamics dealing with the steam engine and turbine. The subject matter is broken down into a number of sub-topics and their relationships to the main topic is an essential element in the understanding of the whole subject. This method of learning is based on the 'entailment structure' concept created by Pask (1972, Ref. 12). The course begins with a presentation of the topics and their interrelations, shown graphically on a topic map. The student is invited to select a topic with which to begin the study. As with programmed learning, a short quiz is presented at the end of every basic step, which if successfully answered returns the student to the topic map. This map offers the remaining topics for further selection. Thus the student has full control of the path taken to explore the subject, picking on whichever item appears most attractive or appealing at any time. The computer is programmed to indicate on the topic map which choices remain to be completed to obtain an understanding of the whole. The student is given the impression that he is collaborating closely with a teacher who is intensely interested in his progress.

Although the public PRESTEL system currently does not offer this degree of interaction, some information providers (the Open University is an information provider) have managed to provide the user with CAL packages. The Printing Industry Research Association (PIRA) has experimented with CAL on topics such as offset lithography and on-line bibliographic searching - see Aston (1980, Ref. 13).

The Manpower Services Commission is working jointly with the British Broadcasting Corporation and the Independent Broadcasting Authority on their 'Young People at Work' project (Ref. 14). This is concerned with the development of telesoftware for education and training. Telesoftware is a generic term for the transmission of computer software either via a viewdata system or broadcast via a teletext system. An evaluation project called 'Telesoftware in Education' was inaugurated in April 1980. This is based at Brighton Polytechnic. The funding is from the Department of Industry. The Council for Educational Technology, the Schools Council, the BBC and the IBA are involved in the steering group. The experimental period is to last 15 months (Ref. 15).

Finally, the technology already exists to connect low cost microcomputers with the PRESTEL and broadcast teletext services. This innovation will be described with the experimental work on microcomputer based CAL which is the subject of the next chapter.

5.65 CONCLUSION

This chapter has outlined some of the uses of CAL in industrial and commercial training. Currently, there are only a few heavily committed CAL users in the UK. These are the large banking organisations, a computer manufacturing company and an airline. Using existing computer installations they have fully integrated CAL into training on a continuing, operational basis. Initially, these organisations provided CAL training for employees who intended using computers or remote terminals



in their jobs - for example, computer operators (and less frequently, programmers) and data entry clerks. More recently they have started to train large numbers of non-computer staff such as bank branch counter clerks, till operators, typists, and so on.

A large number of organisations (about 40) are conducting experiments with CAL. Justification studies are being carried out and software packages are being assessed. However, no long term commitment has yet been made. For example, the Gas Industry is experimenting with sales training for showroom staff and pilot CAL projects are being organised by a large retail distribution group. Similarly, the British Post Office is currently evaluating PLATO as a means of training service engineers. Much other exploratory work is under way.

The large majority of commercial and industrial companies in the UK are still uncommitted. These companies want to see CAL operational in areas similar to their own before making significant commitments.

Overall, CAL is still a little-used medium for training. While experience in a wide variety of training tasks is growing rapidly, the total number of users is still small. However, this situation could change rapidly for the following reasons:

1. The increasing spread of computerisation in public and private sectors of industry and commerce.
2. The decreasing cost of hardware as a result of miniaturisation.
3. The shortage of qualified instructors.
4. The increasing versatility and performance of microcomputers.
5. The availability of computer-based information resources relevant to education and training (teletext and viewdata).

The following table attempts to summarise the wide diversity of systems, languages and the variety of staff currently being trained by committed users of CAL.

TABLE 3.1 SUMMARY OF CAL APPLICATIONS IN A VARIETY OF ORGANISATIONS

Organisation	Location of training	Type and No. of staff trained	Tasks taught by CAL	Computers Used			Computer System and Author or Programming Language used	Other Remarks
				On site	Remote	Based at		
Barclaycard	Head Office Northampton Regional Centres Northampton Leeds Liverpool Birmingham Teesside	Keyboard operators Clerical staff Approx. 400 students per annum	Sales voucher processing Credit review routines Barclaycard issuing and mailing Authorisation procedures Debt collections	IBM 3277 VDUs (Over 700 in use over all regions)	IBM 370/168	Gloucester	IBM Interactive Instructional System (IIS) Coursewriter II Language	The Barclaycard system involves 3000 staff processing 5 million credit cards per annum. 200,000 sales vouchers are processed each day
International Computers Limited	ICL Engineering Training Centre Letchworth	Customer engineers Computer operations 1200 trainees per annum	All diagnostic and operating situations likely to be encountered in own and customers' computer installations	ICL 1903A (Letchworth)	18 VDUs at remote sites		ICL ARIES (Advanced Interactive Educational System)	CAL has been used in ICL since the early 1970s. ARIES is an extension of an earlier system called LORA (Lecturer Oriented Response Analysis)
Tesco Ltd.	Cheshunt, Herts.	Master terminal operators BASIC programmers VDU operators No. of trainees n/k	Procedures for: Retail store operations	IBM 3032 (Cheshunt)	30 terminals at remote sites (expected to increase to 200 in 12 months)		IBM (IIS) Coursewriter II	Experimental since September 1978
British Airways	Head Office Heathrow Airport and 200 locations throughout the world. There are 8 CAL courses (270 hours of training)	Keyboard operators Clerical staff 1300 trainees per annum	Procedures for: Booking clerks Quotation clerks Departure control clerks Ticket issuing Holiday reservation clerks Passenger reservation clerks	A wide range of IBM computers are used - details not available		West London Air Terminal Cromwell Rd. London SW7	British Airways do not use IBM courseware packages. They develop their own courseware programs	
Trustees Savings Bank Ltd.	Newcastle u Tyne	Keyboard operators Clerical staff No. of trainees n/k	Procedures for: Branch counter staff Credit card procedures (see Barclaycard above) - TSB use VISA card system Cashier training	Olivetti Banking Terminals TC349/TC800 Burroughs Terminals	ICL 4/72 Sperry Univac mainframe (details n/k)	York	Sperry Univac MENTOR *ASET (Author System for Education and Training)	*Projection for 1980/81
Midland Bank Ltd.	Head Office Computer Training Branch Sheffield Regional Centres Liverpool, London, Leeds, Birmingham, Bristol, Sheffield	Keyboard operators Programmers Systems analysts Special projects training Approx. 1300 trainees per annum	As above	Borroughs TC500 Banking Terminals Burroughs B876 mainframe		Sheffield	Midland Bank use IBM, ICL and PDP computers. They are not using any manufacturer's system. All programs are written in COBOL at present - see note	The Midland Bank policy (Dr. J.A. Wilson) is to wait for the development of an author language that can be used on any computer. Mills & Allen Communications Ltd. are developing a machine independent author language.

REFERENCES

- (1) Marrow, F., Hooper, R. & Knight, K., Computer Assisted Training Programme: Working Document No. 1, Mills & Allen Communications Ltd., April 1979
- (2) Cook, A.F., Computer Based Training at Barclaycard, Barclaycard, Northampton, 1980
- (3) IBM Corporation, Computer Based Training: User Guide, Form: GE20-0484-20, IBM, April 1975
- (4) Wilson, J.A., The First Stages in Computer Assisted Training Needs, Midland Bank Limited, November 1979
- (5) Hustwit, J. & Rushby, N., 'The PMSL Mentor Service', CAL News, No. 13, December 1979
- (6) Morris, R., Using Computer Assisted Training to Learn How to Locate Faults, Chemical and Allied Products Industry Training Board, November 1979
- (7) Snook, R., Making Major Accident Training Interesting, Royal United Hospital, Bath, June 1980
- (8) Edwards, B., Office Skills Training and the Computer, Speedwriting/Speedtyping Ltd., November 1979
- (9) Labinger, M., A Day in the Life of a Computer Teacher, Speedwriting/Speedtyping Ltd., June 1980
- (10) Spoonley, N., The Control Data Approach to Computer Based Education, Control Data Ltd., London, May 1979
- (11) Fedida, S. & Malik, R., The Viewdata Revolution, Associated Business Press, London, 1979
- (12) Pask, G., Anti-Hodmanship: A Report on the state and prospects of CAI, Programmed Learning and Educational Technology, Vol. 9, No. 5, September 1972
- (13) Aston, M., 'New Technologies for Education', Computer Age, March 1980
- (14) CET, Microelectronics: Their Implications for Education and Training, December 1978
- (15) Jones, C., Independent Broadcasting Authority, London, February 1980
- (16) Post Office Telecommunications, Computer Aided Training: Report on Computer Aided Training Feasibility Study (NDPCAL FS 4/03), conducted by the Post Office Vocational Training Division, THQ/TP71, July 1977

CHAPTER 6

MICRO MULTI-MEDIA CAL EXPERIMENTS

6.1 INTRODUCTION

6.2 THE EQUIPMENT USED

6.21 Hardware

- 6.211 The Commodore PET Microcomputer and Peripherals
- 6.212 The Singer Caramate Tape/Slide Projector.
- 6.213 The Interface
- 6.214 Other Equipment:
 - (a) The Kodak Random Access Slide Projector
 - (b) The Interface
 - (c) The Mainframe System

6.22 Courseware

- 6.221 Overview
- 6.222 Computer Program
- 6.223 Audiotape Production
- 6.224 Slide Production
- 6.225 Use of a Guidebook

6.3 THE TEACHING PROGRAMME - "TELETEXT SYSTEMS"

- 6.31 General Objectives
- 6.32 Learning Objectives
- 6.33 Data Collection
- 6.34 Organisation of Slides into Instructional Units
- 6.35 Methods of Presenting Questions on "Teletext Systems"

6.4 EVALUATION OF SYSTEM

- 6.41 Introduction
- 6.42 Summary and Detailed Information from the Printer
- 6.43 Design of Questionnaire
- 6.44 Questionnaire Analysis

6.5 COMMENTS ON SOFTWARE DESIGN

- 6.51 Program Analysis
- 6.52 Future Design Recommendations

6.6 CONCLUSIONS

- 6.61 Strategy for Pre-Test and Post-test Questions
- 6.62 Preparation of Data Bank of Material
- 6.63 Preparation of Microcomputer Program for Random Access Slide Projector
- 6.64 Author's View

CHAPTER 6

MICRO MULTI-MEDIA CAL EXPERIMENTS

6.1 INTRODUCTION

Earlier chapters have discussed the need for information to be presented by more than one channel using a variety of media. PLATO, probably the most well-known computer based multi-media system, has already been described - see Chapter 4.

Although a powerful and impressive system, PLATO has a cost effectiveness problem (see Section 4.32). Consequently, its current availability in an increasingly severe economic climate is extremely limited.

The CYCLOPS system being developed by the Open University (also described in Chapter 4) uses standard equipment and will probably overcome the problem of cost effectiveness. However, it is still in an experimental and development stage and consequently has a very limited range of courseware.

The widespread availability of low cost microcomputers over the last few years offers possibilities of significant cost reductions in multi-media CAL development. A particularly attractive feature of these computers is the provision of interfacing connectors. These enable them to be connected to external equipment. In the UK, at Glasgow University Kenny (Chapter 4, Ref. 10) demonstrated that an inexpensive microcomputer could have tape/slide and videotape equipment interfaced to it. Kenny reported a major disadvantage of the large system which had previously been used. This was that electrocardiogram (ECG) recordings or X-ray films could only be described to the student in the text of the CAL unit. It was decided that it would be better to have such visually important items presented to the student in picture form. The student could examine the pictorial presentation and then have his understanding of the record or film

questioned by the computer and corrected if necessary. In this case the microcomputer, in addition to being very much cheaper, had provided a visual representation of learning material which was not available on the larger system. The scope for interfacing a wide range of educational resources has also been described in the development of the AIDE system in the University of Southern California (Chapter 4, Ref. 7). A major objective in the development of AIDE was that only commercially available microcomputer and other hardware should be used.

When the microcomputer can be interfaced to either a local or remote mainframe computer, a sophisticated teaching system can be developed which may prove to be as useful as and, perhaps, more effective than systems like PLATO.

In this chapter the results of some investigations into the use of micro multi-media CAL is described. The construction of a microcomputer based tape/slide system is outlined along with the results of some experiments designed to assess the acceptability of the system.

6.2 THE EQUIPMENT USED

The purpose of the experiments was to design a multi-channel communication system using a variety of educational resources. A major objective was to use low cost components which were likely to be available in colleges of further education and training establishments.

The multi-media approach to CAL which was adopted in the initial experiments can be summarised as follows:

1. Sending a visual message by the projection of pictures and diagrams with 35mm slides.
2. Reinforcing the visual communication with an oral message synchronised with the above slides on an audio cassette tape.

3. Providing a printed message by means of a guidebook which reproduces the pictures and diagrams (in black and white only). The text in the guidebook is based upon the script which was used for the audio tape. However, rather more information is provided in the guidebook due to the time constraint of the audio tape (see below).
4. Coordinating all the above messages by means of a microcomputer. This provides interaction with the student by posing questions on the material presented, allowing the student to key-in answers and by providing remedial and reinforcement frames of information on the computer screen.

A diagram illustrating the above components is presented as Figure 6.0. The equipment used to construct this multi-media learning system is described below.

6.21 Hardware

6.211 The Commodore PET Microcomputer and Peripherals

A Commodore 'Professional Computer' 3032 Series with 32K storage was used in all the experiments. The manufacturers, Commodore Business Machines (UK) Ltd., gained a world-wide reputation in the 1970s for its calculating devices. It is now one of the market leaders in low cost computers which have the generic name PET. This is an acronym for Personal Electronic Transactor. Since their introduction into the UK about three years ago prices have actually fallen and the various models cost between £500-1000 - a price within the budgets of most schools and training departments.

The keyboard of the microcomputer is standard size with the letters in the usual "QWERTY" layout. To the right of the typewriter keyboard (see Figure 6.1) is a numeric pad for the numbers. A TV type screen is positioned above the keyboard. The illuminated screen or visual display unit (VDU) has a black background and alphanumeric characters and graphics are produced in

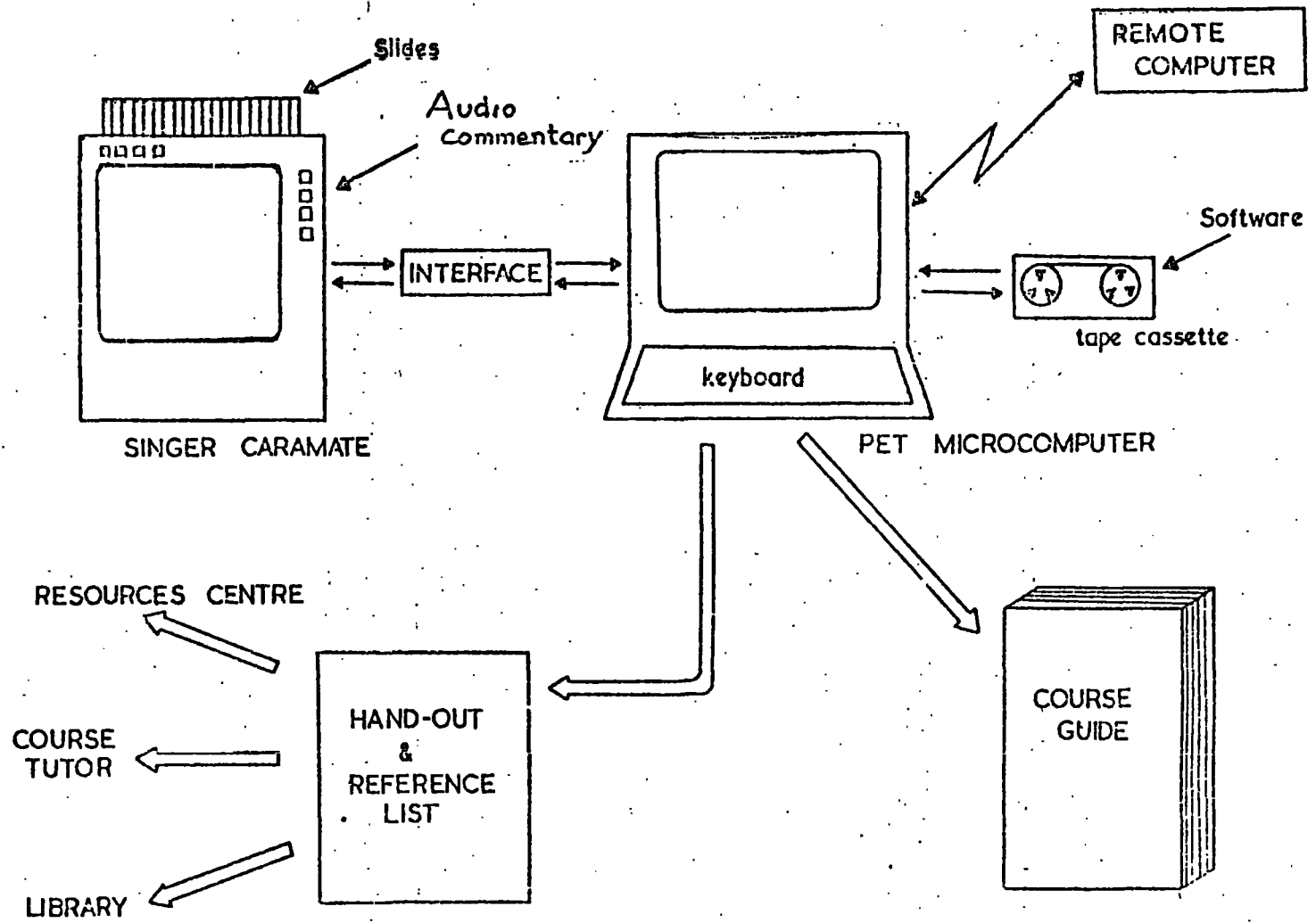

Figure 6.0

EQUIPMENT INITIALLY USED IN THE MICROCOMPUTER
CAL EXPERIMENT

SINGER CARAMATE
SLIDE PROJECTOR

COMMODORE PET
MICROCOMPUTER



Figure 6.1

green. This combination is very restful on the eyes. The VDU can accommodate 1000 alphanumeric characters. A maximum of 40 characters can be entered on one row and the capacity is 25 rows. There are good graphics facilities. The symbol keys used to produce these graphics fit the same space that a letter or number would. The symbols include playing card symbols such as clubs or diamonds (for gaming), cross hatch patterns, lines in various positions and segments of circles. Everything that appears on the screen can be displayed in 'reverse video'. This results in a black on green image rather than a green on black display. A title frame produced in graphics for the experiment is shown in Figure 6.2

The VDU presents a sharp, stable and glare-free image. A screen editing feature allows letters, numbers or graphic symbols to be erased and replaced with corrections. Screen editing is achieved by using symbol keys called cursor control keys. The exact position on the screen is obtained by moving the cursor (which is the size of a character) vertically, horizontally, left or right. The cursor control keys are illustrated in Figure 6.3.

All data and programs can be stored on standard cassette tapes or flexible (floppy) disks. Dual flexible disk units for backing storage have a capacity of 360K bytes. Up to 8 disk units can be connected to each Commodore PET.

Illustrations of the tape cassette used in the initial experiments and the disk drives used in later experiments are shown in Figure 6.4.

Instructions are entered into the microcomputer in BASIC, an interactive computer programming language. Once the machine is connected to a mains supply, writing programs or loading an already prepared program can be performed immediately. Programs could be listed on an Anadex (Model DP-800) printer. This was attached to the PET by means of a special RS232-C serial interface produced by

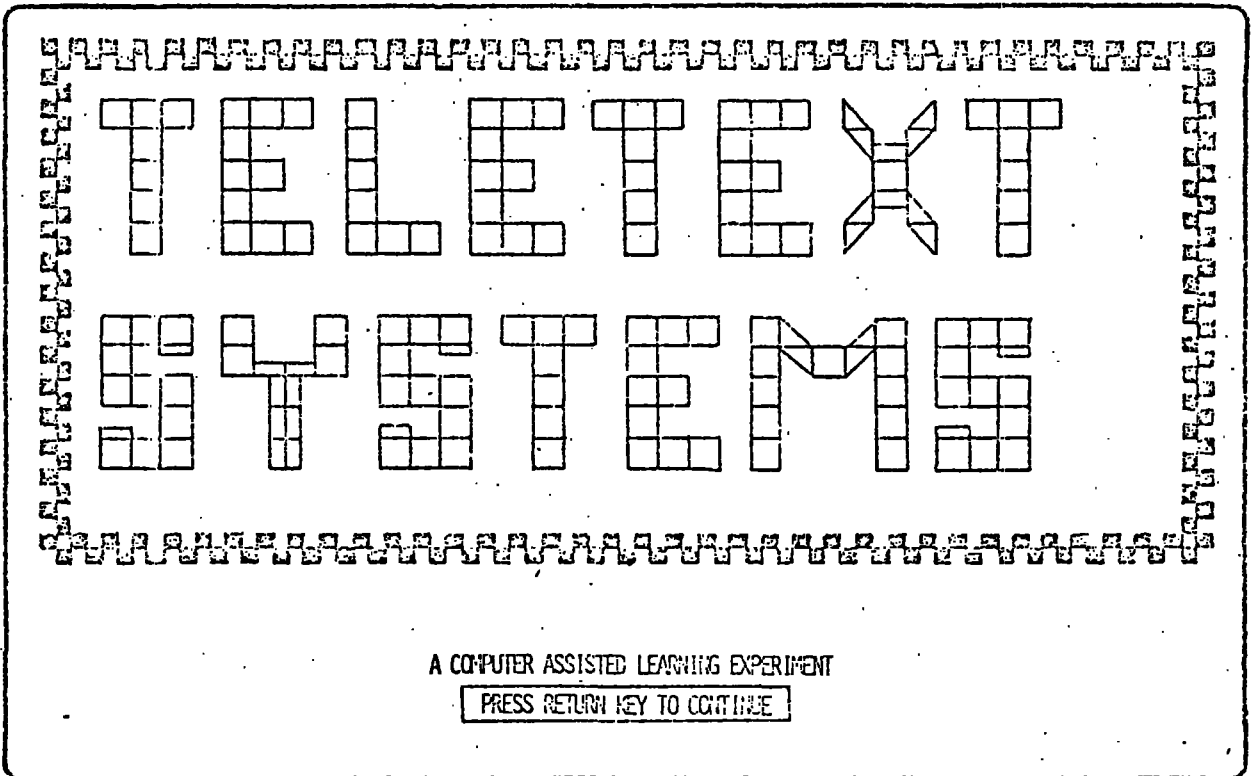

Figure 6.2

CURSOR CONTROL KEYS

















Function	Symbol	Code (ASCII)	Our Notation
CLEAR SCREEN		147	
HOME CURSOR		19	
CURSOR DOWN		17	
CURSOR UP		145	
CURSOR LEFT		157	
CURSOR RIGHT		29	
REVERSE FIELD		18	
RESET REVERSE		146	

Figure 6.3

RANGE OF PERIPHERALS IN USE FOR
THE CAL EXPERIMENT

SINGER CARAMATE
TAPE/SLIDE PROJECTOR

COMMODORE PET
MICROCOMPUTER 32K

FLEXIBLE DISK

DISK DRIVE

TAPE
CASSETTE

CARAMATE/PET
INTERFACE

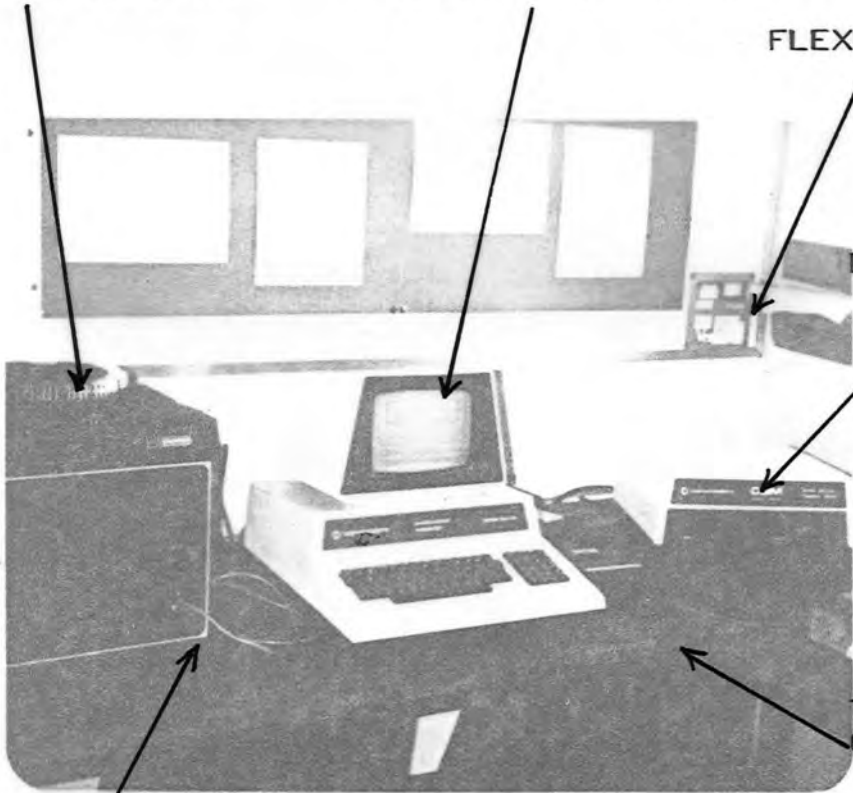

Figure 6.4

Small Systems Engineering Ltd. (Ref. 1). Unfortunately, this printer was unable to reproduce the graphic character set of the PET and so, in the listings presented in Volume 2, numeric codes corresponding to these graphics are used.

6.212 The Singer 'Caramate' Tape/Slide Projector

The tape/slide equipment used consisted of the following components:

1. A carousel, or slide magazine which could hold a sequence of 35mm slides. The model used has a capacity of 80 slides.
2. A cassette audiotape recorder/player. This could replay a commentary synchronised with the 35mm slides for a period up to 60 minutes without changing the cassette.
3. A front projection screen measuring 10" x 10" and lit by a 300 watt lamp for viewing the slides.
4. A set of controls which were simple to operate. These were used to start and stop the equipment, and control the slides and either record or play back the audiotape.

The device weighs about 25lbs. It is equipped with a carrying handle and can easily be transported between classrooms. This type of tape/slide equipment has been available for a number of years and is in wide use in both education and training establishments. There are several models on the market; fortunately there is a degree of standardisation allowing interchangeability of carousels and audiotapes. The Singer 'Caramate' used in the initial experiments was several years old. More recent models have the facility of rear projection in addition to the front projection mentioned in (3) above. They also have a more powerful amplifier for audiotape playback. These features enable the same slides with audio commentary to

be presented to a large group in a classroom equipped with a suitable screen. Another useful feature available on recent models is the 'Magna Frame' system. This enables any slide being projected to have the details enlarged by up to 50%. A photograph of the tape/slide device positioned alongside the Commodore PET microcomputer is illustrated in Figure 6.1.

The original interface which was constructed, and which is described below, can be seen positioned between the two pieces of equipment.

6.213 The Microcomputer/Tape/Slide Interface

The design of the interface was based upon the work of Kenny (Chapter 4, Ref. 20). Circuits are needed to enable the microcomputer to control the audio cassette motor and the slide change mechanism. The circuit diagram is presented in Figure 6.5. The interface circuit details which provide an explanation of the diagram are as follows (see wiring diagram, Figure 6.6):

- (a) The Commodore 3032 Series microcomputer has a 'user' port, consisting of eight pins that can be set individually at 0 volts or +5 volts. The pins are used to trigger relays which control the power supply to the slide change mechanism and to the audiocassette motor. When a slide is changed, a signal of +5 volts is passed to one of the pins at the computer interface and the change in voltage is noted by the computer.
- (b) The second of the two ports is a standard IEEE-488 interface and is used for interfacing with the printer or flexible disk unit.
- (c) The parallel user port is used to control the tape/slide equipment. The sequence of program instructions is as follows:

POKE 59459,255: POKE 59471,A

CIRCUIT DIAGRAM FOR THE PET-CARAMATE INTERFACE

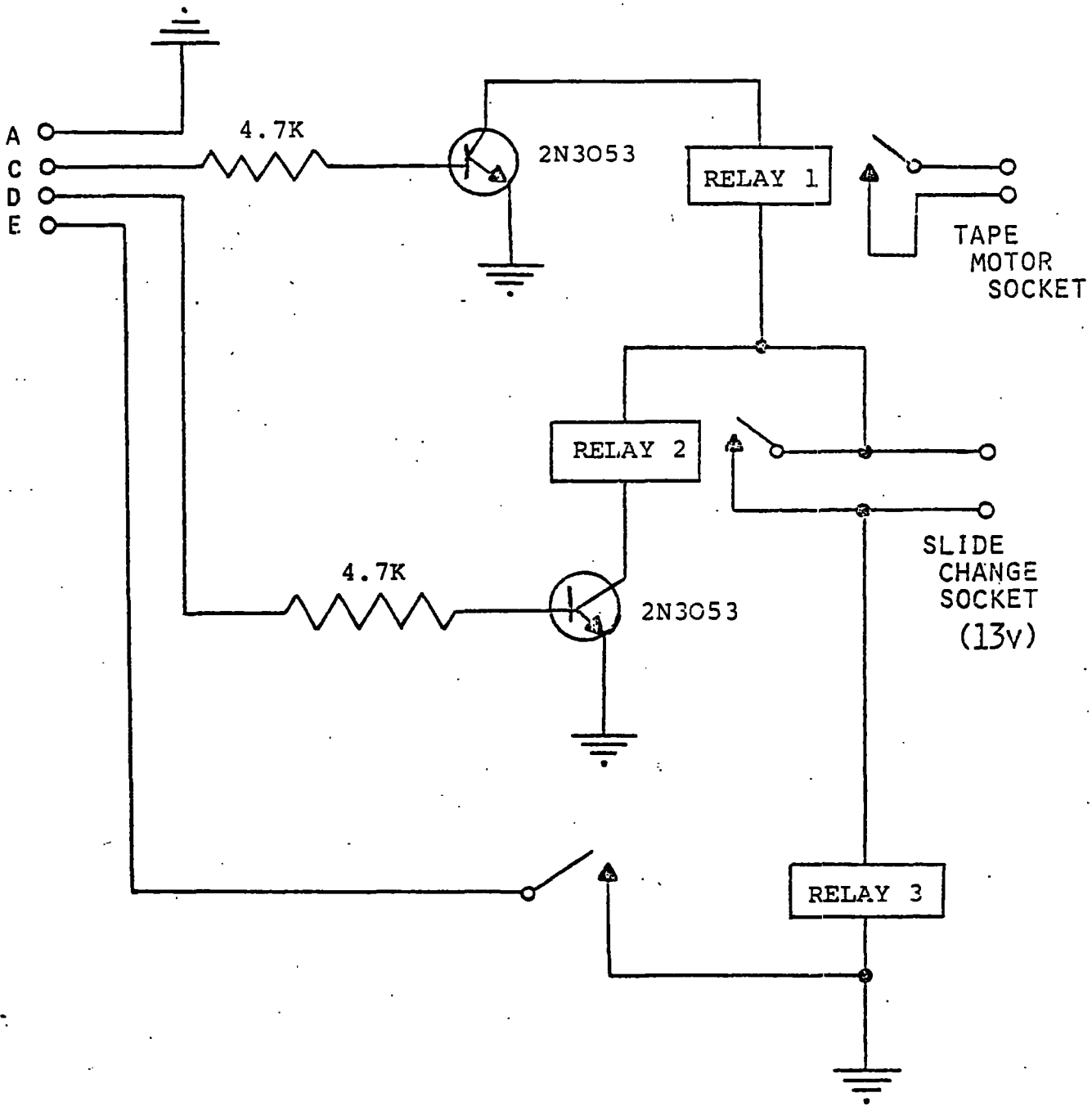

Figure 6.5

WIRING DIAGRAM FOR THE PET-CARAMATE INTERFACE

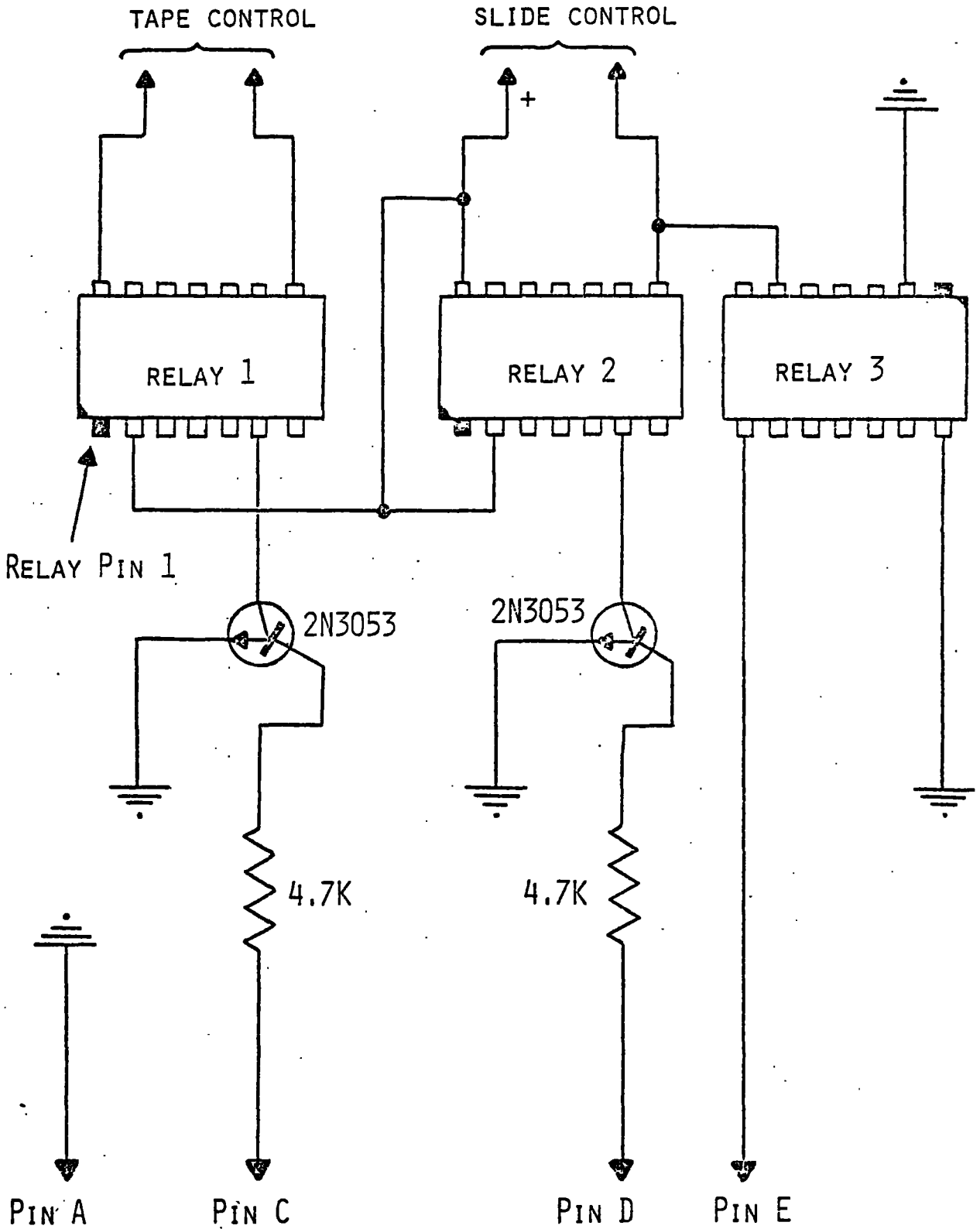

Figure 6.6

If A = 0, then all the pins at the user port are set at 0 volts. When A = 1, pin 1 goes to +5 volts and operates the first dual-in-line (DIL) read relay (RELAY 1). The relay controls the power supply to the audio/cassette motor. By putting pin 1 either to +5 or to 0 volts, the motor drive can be started or stopped, thus controlling the delivery of the audio tape/slide presentation.

- (d) If A = 2, then pin 2 on the parallel user port goes to +5 volts. This operates the second DIL relay (RELAY 2). This activates the slide change mechanism by closing the two contacts at the remote slide change sockets and the slide in the back projector is changed.
- (e) During the time the presentation is being given to the student, pins 1 and 3 are kept at +5 volts with the instruction POKE 59471,5. The positive voltage on pin 1 keeps RELAY 1 closed and supplies power to the audio cassette motor. Pin 3 is kept at +5 volts until a slide change is brought about by a 1 - kHz tone pulse on the second audio channel.

The remote slide change connection on the Caramate consists of two sockets. The socket nearest the screen is driven high when a slide change occurs. This is arranged to close the third relay (RELAY 3) and grounds pin 3 to 0 volts.

The computer continually loops, observing the voltage at pin 3 using a statement of the form:

```
40 IF PEEK (59471) = 5 THEN 40
```

When pin 3 goes to zero, the computer notes this as a slide change. When a predetermined number of slides has been changed, the audio cassette motor is stopped and the presentation is interrupted for questions to be answered by the student.

The interface was very economical to construct. Details of the components used and other technical data are contained in Barker & Yeates, 1980 (Ref. 2).

6.214 Other Equipment

Later experiments necessitated:

- (a) use of a Random Access Slide Projector (RASP),
- (b) construction of a Microcomputer/RASP Interface,
- (c) use of the storage facilities of a local mainframe computer,
- (d) establishing telecommunication links with a remote computer.

These will be briefly described in turn.

(a) The Kodak Random Access Slide Projector

The teaching strategy adopted for the first experiment was to present slides in a strict sequential order to the student. The Caramate tape/slide equipment described above was adequate for this purpose. A later experiment involving pre-test and post-test questions provided an opportunity to investigate the use of a random access slide projector. With this device it is possible for slides to be selected and shown in any order. The equipment used was a Kodak 'Carousel' S-RA2000 projector (Ref. 3). The carousel holds up to eighty 35mm slides. It is the same type of carousel that was used with the Caramate tape/slide projector. This interchangeability was very useful as it enabled a carousel of slides to be transferred from one experiment to the other. The access time of a slide on the RASP depends upon its position in the carousel. It can take between $1\frac{1}{2}$ and 5 seconds to select a required slide for showing. This is, of course, a mechanical limitation of this device. The overall strategy for the experiment involving the RASP will be described later.

(b) The Microcomputer/RASP Interface

The construction of the microcomputer interface was based upon a circuit diagram and technical data contained in a special application brochure supplied by Kodak (Ref. 4). Details of the construction and components used are presented in Barker and Yeates (1980, Ref. 2).

(c) The Mainframe System

In the initial experiments the microcomputer was a detached processing device.

A telecommunications link was established which connected the microcomputer to a large remote computer system (Northumbrian Universities Multiple Access Computer - NUMAC) which is built around a powerful central processor, an IBM 370/168.

The link enabled the microcomputer system (equipped with appropriate communications hardware) to act as both a detached and an attached processor. Consequently, the long range intention is that a large repertoire of instructional material can be accessed using either a local or remote back-end data base processor. The material stored at present consists of the CAL computer program, and the script for the "Teletext Systems" learning package.

The long term intention is that the instructional material stored may be used either in an industrial training environment or by schools/colleges within the local education authority. In the latter case it may be possible to distribute the software via a temporary or "transient" telecommunications link.

6.22 Courseware

6.221 Overview - Teaching Strategy

The instructional schema is presented in Figure 6.7.

The microcomputer introduces the subject to the student with an appropriate title frame displayed on the screen - see example Figure 6.2. There will be an instruction on the title frame "Press Return Key to Continue". This will result in an explanatory frame of information being displayed as illustrated in Figure 6.8. The student is asked to enter his name and course code. The instruction "Press 'Advance' on the Caramate" starts the slide sequence. "Press 'Play'" on the Caramate starts the audio commentary. The student is then shown a group of slides which is called a unit. The slides are synchronised with the audio commentary. The pulsing mechanism for the slide changes is timed by the computer. At the end of the first sequence of slides the computer stops the slide projector and presents some multiple-choice questions on the VDU. If the student answers correctly he is given encouragement. Then the computer screen presents reinforcement information explaining why his answer was the correct one of the four possible answers he could have given. He is then directed to watch some more slides and listen to the commentary which is automatically started by the computer. If he answers incorrectly the computer screen presents him with the correct answer and a detailed textual explanation. He can then type 'GO' to proceed with the programme or 'HELP' if he is in difficulty. Typing 'HELP' directs him to a Guidebook on the subject which every user of the system is provided with. Page(s) of the guidebook contain diagrams and/or pictures of what he has seen on the Caramate plus a textual explanation of what he has heard from the audio commentary.

Answers to multiple-choice questions are obtained by pressing keys 'A', 'B', 'C' or 'D'. If the student presses

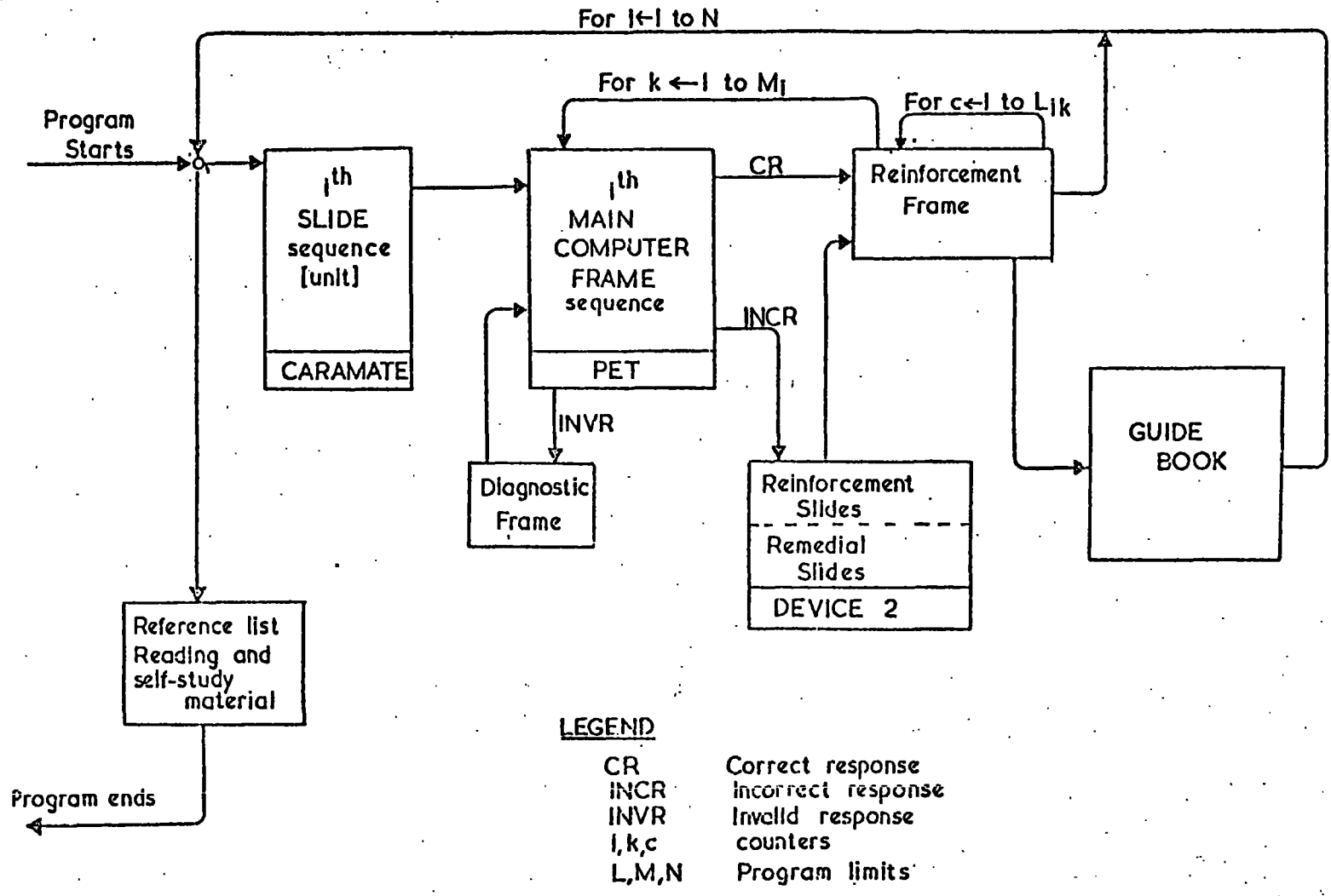

Figure 6.7

AN EXPLANATORY FRAME OF INFORMATION

NAME : name-display

COURSE: course-code-display

PRESS ADVANCE ON THE CARAMATE

PRESS PLAY ON THE CARAMATE

WATCH THE SLIDES . . .

LISTEN TO THE TAPE RECORDING . . .

YOU'LL BE ASKED QUESTIONS ABOUT WHAT
YOU SEE AND HEAR

Figure 6.8

some other key this is regarded as an invalid response and a diagnostic frame of information appears on the VDU. An example of a diagnostic frame of information is presented in Figure 6.9.

6.222 Preparation of the Program for the CAL Experiment

The program responsible for running the CAL experiment was written in the BASIC programming language. An example of typical BASIC code used to produce one of the introductory frames of information - see Figure 6.10 - is presented below:

BASIC CODE TO PRODUCE FRAME 1

```
10 PRINT "☐↓↑↑↑↑↑>>>>COURSE: TELETEXT SYSTEMS"
20 PRINT "↑>>>>*****"
30 PRINT "↑↑↑>>>>>ENTER YOUR NAME:"
40 PRINT "↑>>>>>ENTER YOUR COURSE CODE:"
50 PRINT "↑↑↑>>>PLUG ME IN...."
60 PRINT "↑>>>SWITCH ON TAPE SLIDE EQUIPMENT..."
61 PRINT "↑>>>TYPE 'GO' WHEN YOU ARE READY TO START"
70 PRINT "↑>>>CONTACT YOUR TUTOR (PHILIP G. BARKER)"
80 PRINT "↑>>>..... IF YOU HAVE ANY PROBLEMS
90 PRINT "☐↓↑↑↑↑↑↑↑↑↑"
100 INPUT "↑>>>>>ENTER YOUR NAME:";A$
110 INPUT "↑>>>>>ENTER COURSE CODE:";B$
120 INPUT "↑↑↑↑↑↑↑↑↑↑>>>>";GO$
```

The program contained over a thousand statements. It is apparent from the above example that a high proportion of these were PRINT statements. As the symbols on the Commodore PET keyboard look rather complex when reproduced, a simple notation was adopted in the above illustration - see Figure 6.3.

As about 600 PRINT statements were required for the program, a Frame Layout Chart was used for preparing these statements for keyboard entry. An example of a Frame Layout Chart is presented as Figure 6.11.

An Example of a Diagnostic Frame

COMMODORE PET MICROCOMPUTER - FRAME LAYOUT CHART

SCREEN HOLD TIME:
SOUND EFFECT:
CONTINGENCY ACTION:
CONTEXT:

FRAME NO:
PROGRAM:
CODE SECTION:
DATE:
AUTHOR:

COMMENTS

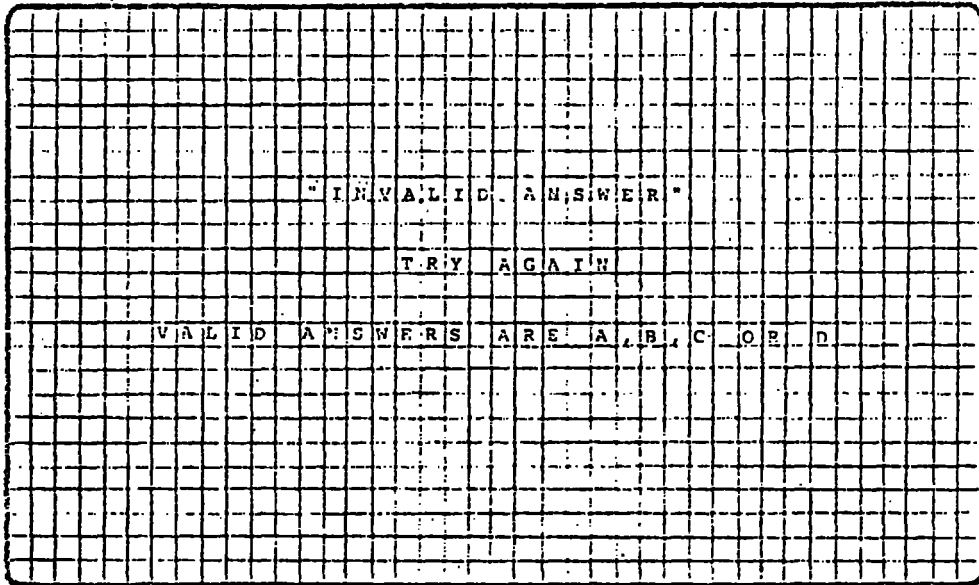

SCREEN SIZE: 25 x 40

Figure 6.9

AN INTRODUCTORY FRAME OF INFORMATION

COURSE : TELETEX SYSTEMS

ENTER YOUR NAME : name-slot

ENTER YOUR COURSE : course-code-slot

PLUG ME IN . . .

SWITCH ON TAPE SLIDE EQUIPMENT . . .

TYPE 'GO' WHEN YOU ARE READY TO START

CONTACT YOUR TUTOR (PHILIP G. BARKER)
IF YOU HAVE ANY PROBLEMS

go-slot

Figure 6.10

An Example of a Introductory Frame

COMMODORE PET MICROCOMPUTER - FRAME LAYOUT CHART

SCREEN HOLD TIME: User driven
SOUND EFFECT: -
CONTINGENCY ACTION: -
CONTEXT: Introductory frame

FRAME NO: 1
PROGRAM: Teletext Systems
CODE SECTION: 100-220
DATE: 21.1.80
AUTHOR: P.G. Barker

COMMENTS

C	O	U	R	S	E	:	T	E	L	E	T	E	X	T	:	S	Y	S	T	E	M	S											
*	*	*	*	*	*	*	*	*	*	*	*	*	*	*	*	*	*	*	*	*	*	*											
E	N	T	E	R	Y	O	U	R	N	A	M	E	:																				
E	N	T	E	R	C	O	U	R	S	E	C	O	D	E	:																		
P	L	U	G	M	E	I	N											
S	W	I	T	C	H	O	N	T	A	P	E	S	L	I	D	E	E	Q	U	I	P	M	E	N	T								
T	Y	P	E	'	G	O	'	W	H	E	N	Y	O	U	A	R	E	R	E	A	D	Y	T	O	S	T	A	R	T				
C	O	N	T	A	C	T	Y	O	U	R	C	O	U	R	S	E	T	U	T	O	R	(P	.	G	.	B	A	R	K	E	R)
I	F	Y	O	U	H	A	V	E	A	N	Y	P	R	O	B	L	E	M	S														

SCREEN SIZE: 25 x 40

Figure 6.11

The load size of the program was over 30,000 bytes, which represented 93% of the capacity of the microcomputer. During the initial experiments only a tape cassette was available for storing the program. Due to its size it took 11 minutes to load on this device. Later the program was loaded on to a flexible disk when a dual drive disk unit became available. The program loading time was reduced from 11 minutes to under 5 seconds.

A complete analysis of the program is presented in Section 6.5 where it is suggested that if a random access storage device had been available when the program was first constructed, a different strategy would have been used. The resultant program would have been less wasteful of storage capacity available. A 'Data-Item-Name Table' showing the meaning of the important variable names used in the program is presented in Section 6.5 along with a 'Storage Allocation Map'. The latter gives an indication of the way in which the computer's memory is allocated to the different functional modules from which the program is constructed. A complete listing of the program is presented in Volume II.

6.223 Audiotape Production

Audiotape production for the CAL experiment required the following materials and equipment:

1. A script, marked with "cues" to initiate slide changes and synchronisation with the microcomputer program.
2. The Caramate slide projector containing the slides in the order they are to be presented and appropriately numbered.
3. Tape recording equipment.

The method of production is discussed below.

Script Preparation

The preparation of the script commences with the author preparing brief notes for each slide. The content of the slides will be discussed later - see Section 6.3. The draft script was prepared as follows:

- (1) Each slide was given a number and brief description.
- (2) The narration to accompany each slide was written - initially on 6" x 4" cards.
- (3) The draft script - see Figure 6.12 - is then cue-marked (●) to indicate positions at which slide changes are to take place.
- (4) At a later stage further cue marks (*) were added to the script. These indicate positions during the narration at which the computer interrogates the student.

Preparation of Trial Audiotapes

Using the Caramate slide projector and the notes a trial tape was made on a simple cassette tape recorder. Before the actual recording was made the slides were shown on the Caramate and the notes rehearsed to get the feel and pace of the intended programme. Each slide was projected only long enough for the information to register and no longer. This meant different timing for different slides. This variety of pace helps to keep the presentation interesting and dynamic. The trial runs resulted in changing the sequence of some slides, making additional slides and deleting or adding words to emphasise points that had been overlooked.

When the words and pictures flowed smoothly the trial tape was ready for adding pulse signals. Slide change cues (●) were noted on the draft script. The cassette tape was played back in the Caramate with the accompanying slides. As each cue mark (●) is reached

Example of Draft Script

SLIDE 0.5 (Blue background)

This is the sound track of the tape-slide presentation "TELETEXT SYSTEMS". ●

SLIDE 1 (Title slide) ●

SLIDE 1.5 (Communication)

During their everyday lives people need to communicate one with another. The purpose of communication is to disseminate information. This information may be used as a means of solving problems or for carrying on conventional social discourse. Alternatively, it may be used purely for its entertainment value. ●

SLIDE 2

People communicate in a variety of ways: through talking and listening, through writing, by drawing pictures and diagrams and, of course, by reading. Very often listening to a radio broadcast or watching a television programme can constitute very effective methods of receiving information. ●

SLIDE 2.5

Communication is the transmission of information from a source to a destination via a suitable communication channel. It can be a one-way or two-way process. ●

SLIDE 3

A newspaper, a book or a television programme each represent a unidirectional or one-way means of communication. The author of a newspaper article or of a book has little opportunity of interacting with the recipient of the information that he dispatches. ●

SLIDE 4

Two-way or bi-directional communication involves information flow between the originator of the information and its recipient. For example, a conventional conversation between two people, either face to face or via a telephone system, are examples of bi-directional communication. In this mode of communication the media used to convey information need not be the same. The third example shown in the slide, mode C, illustrates how two different channels may be used to carry information between those involved in the communication process. ●

SLIDE 4.5 (Now turn to the computer screen) * ●

Legend:

- Slide change
- * Wait 4 seconds

in the commentary the 'ADVANCE' and 'RECORD' keys are pressed simultaneously. This action results in a slide-changing pulse being 'recorded' on one track of the audiotape. It was also necessary to allow a pause in the commentary after each sequence (or unit) of slides had been projected. During the pause in the commentary a slide was projected with the instruction "NOW TURN TO THE COMPUTER SCREEN". After some experimentation it was discovered that a pause of 4 seconds was adequate for the microcomputer to stop the tape commentary and slide mechanism. In this period the first of the multiple choice questions relevant to the unit of slides shown would appear on the microcomputer VDU. Because the trial tape was made on amateur equipment in a room which was not designed for the purpose, the resulting tape contained various extraneous noises. For example, the noise caused by pressing and releasing the cassette recorder 'PAUSE' button was particularly distracting. By arrangement with Newcastle upon Tyne Polytechnic (PETRAS) - Polytechnic Educational Technology Resources Advisory Service - facilities were made available for the author to make another audiotape. The recording at PETRAS was made in a professionally equipped sound studio with a technician monitoring tone and volume on a reel-to-reel tape recorder. From this master tape several copies were made in cassette form. Slide change pulses were added using the Caramate. For split-second timing it was found necessary to press the 'ADVANCE' key on the slide projection equipment slightly ahead of the appearance of the slide on the Caramate screen. This allowed for the mechanical time lag. For example, it was found that the best time for a slide change may be right in the middle of a sentence. Once the cues were recorded on the audiotape the slides were automatically changed without any distracting effects. (Some makes of automatic slide change equipment emit a distracting 'beep' tone.)

6.224 Slide Production

This section describes the materials and equipment used to produce 35mm slides for the experiments. The content of the slides is not included in this description as this is detailed in Section 6.3 (The Teaching Programme - "Teletext Systems").

All the slides used in the experiments were produced by the author. The following materials were used:

- (1) Pictures and diagrams obtained from relevant books, technical journals, brochures and publicity material.
- (2) Artwork produced by the author. The same artwork was subsequently used to illustrate the guidebook - see Section 6.225 below.
- (3) 35mm colour slides loaned by the Independent Broadcasting Authority. (Permission was given to the author to copy the slides) It should be noted that under 5% of the slides were produced in this way.

Four types of film were used to produce a variety of effects to stimulate interest in the visual material:

- (i) AGFA CT18 colour reversal film. This was used for copying photographs from coloured brochures and for copying loaned 35mm slides.
- (ii) AGFA DIA-DIRECT film. Used for copying black and white photographs, line drawings and diagrams from technical literature.
- (iii) KODAK VERICOLOR SLIDE FILM Ref. 5072. Used for producing white or light coloured lettering on a coloured background.

- (iv) KODALITH ORTHO FILM TYPE 3 Ref. 2556.
Used for producing white or coloured lettering on a black background.

The last two types of film, types (iii) and (iv), are used to produce 'Reverse Text' slides. As these have a number of advantages over other photographic methods, their use is described below.

The advantages claimed for reverse-text slides are as follows:

- (1) They produce excellent legible images in a semi-darkened room. (During the CAL experiments, room darkening was not possible; despite this there were no complaints about legibility.)
- (2) They are particularly useful for charts, flow diagrams and line drawings.
- (3) Reverse text slides have black or dark coloured backgrounds. White or light coloured backgrounds on slides cause glare that results in eye strain.
- (4) A variety of dark coloured backgrounds increases visual interest which helps effective communication of messages. Different effects were obtained by the use of colour filters.
- (5) The use of reverse text slides practically eliminates dust, dirt, fingerprints, etc. from projected screen images - a common problem with light coloured backgrounds.

A simple lens reflex camera (Practika Super TLR) was used to photograph lettering and artwork. As some of the lettering to be copied was very small, various close-up lenses (+1, +2 and +3 diopters) were used to obtain the necessary magnification. Additional lighting was

necessary for the type of work and films used. Two tungsten - halogen 3400K lamps positioned at 45 degrees on each side of the artwork were found to be effective.

Exposure times and aperture settings (f-numbers) were determined by making trial exposures for each type of film used. All slides used in the experiments were mounted in glass slide mounts. If this is not done there is a danger that the heat from the 300 watt lamp in the Caramate slide projector could cause distortion of the picture. On some slides photographic dyes were used to colour white lettering or line drawings on a black background. If this type of slide is not protected by glass the colour will quickly fade. After mounting the slides the final operation was to 'thumb spot' them. This involved placing light coloured adhesives 'spots' in the lower left hand corner of the slide to indicate when the slide reads correctly on hand viewing. Sequence numbers were then written on the spots and an adhesive label added to describe the slide topic.

6.225 Use of a Guidebook

The major purpose of the Guidebook is to provide remediation material to which the student may be directed by the computer. Other uses are:

- (1) To introduce the topic and thus reduce the amount of textual information required on the computer screen.
- (2) To specify general and learning objectives - described in Section 6.3 below.
- (3) To provide additional text and diagrams to enlarge upon information presented by other media used in the programme.
- (4) To introduce the student to books and other reference material on the subject.

The Guidebook produced for the experiments is presented in Volume II. Most of the artwork needed to produce the slides is presented in the Guidebook. Additional black and white illustrations were added where appropriate because reprographic facilities were not available for examples in colour. This is evidenced by the reading list on page 58 which directs the student to a wider range of materials. The information in the Guidebook could be kept up-to-date by storing the contents on a large mainframe computer with text processing facilities. This is a future development of the experiment which will be discussed later.

6.3 THE TEACHING PROGRAMME - TELETEXT SYSTEMS

The first step in planning the teaching programme was to establish the communication objectives. Initially the target audience was to be 2nd Year Computer Science degree students. The subject of "Teletext Systems" was chosen as being of topical interest to students who had a basic knowledge of computers and telecommunications.

6.3.1 General Objectives

The overall objectives of the CAL experiment were to enable the students to recognise:

1. the creation of various types of teletext system as a result of the converging technologies of television, telecommunications and electronic data processing,
2. the role of teletext systems in solving some communication problems,
3. the potential value of such systems for the future education of society.

6.32 Learning Objectives

The learning objectives of the multi-media CAL package were to enable the student to identify:

1. the major limitation, that is the lack of interaction in some of our present methods of communication,
2. the methods of operation of the BBC and IBA broadcast teletext systems,
3. the differences and similarities between these systems and the Post Office interactive viewdata system called PRESTEL,
4. the type of systems called "mixed media systems",
5. how these mixed media systems are being developed for future educational uses.

6.33 Data Collection

Research for the project involved the study of books and brochures, reading relevant technical journals and contacting knowledgeable people. Data collection necessitated correspondence and discussions on current developments with the following:

1. the Engineering Information Department of the Independent Broadcasting Authority,
2. the British Broadcasting Corporation,
3. the Post Office Telecommunications Research Unit concerned with the development of PRESTEL,
4. the Open University (developments in CYCLOPS),
5. the Control Data Corporation who are marketing PLATO in the UK.

The information obtained provided the basis for the artwork to produce the slides by the methods already described. A total of 66 slides were subsequently produced. The slidefile and an index of these slides are presented in Volume II of this thesis. Books and other sources of information used for slide production are also listed there.

6.34 Organisation of Slides into Instructional Units

To implement the teaching strategy described in Section 6.221, the slide collection was organised into instructional units. The content of the programme was divided into 7 such units. A brief description of the slide contents in each unit is illustrated in the following table:

ORGANISATION OF SLIDES INTO INSTRUCTIONAL UNITS

Unit No.	No. of Slides	Brief description of Slide Contents
1	7	Introduction to communication - examples of one-way and two-way communication
2	8	Introduction to broadcast teletext systems
3	6	Use of colour in teletext systems. Teletext data organisation
4	4	Teletext editing operations
5	6	Introduction to viewdata systems
6	14	Viewdata (PRESTEL) examples. Introduction to mixed media teletext systems
7	14	Examples of PLATO and CYCLOPS systems

6.35 **Method of presenting questions on "Teletext Systems"**

A total of 20 questions were devised to test if the objectives had been achieved. For each question there were 4 possible answers. All the questions and multiple choice answers, together with remedial material for each answer, is presented in Volume II. However, to provide an example of the method of presenting questions to the student, Unit 1 which contained one question is reproduced below:

Question

1. What is the major disadvantage of some conventional methods of communication such as books, manuals and newspapers?

Multiple Choice Answers

- A Revision and distribution is costly.
- B The content and quality varies.
- C There is no interaction
- D There is no guarantee of understanding

Key-in of correct answer

The student was given a word of praise and invited to proceed.

Key-in of incorrect answer

(If the student answered incorrectly the following remedial text would appear on the VDU of the microcomputer):

"The answer is 'C'. There is no interaction. Books, manuals and newspapers are examples of one-way methods of communication. Their major disadvantage is that you cannot ask them a question, that is, there is no interaction."

For each question, multiple choice answer, remedial and reinforcement frame, a microcomputer frame layout chart was prepared. Question and reinforcement material was structured for the computer program in the manner illustrated in Figure 6.13 for each unit of instruction. To illustrate the way in which the software was produced, Question 4 taken from Unit 2 is used as

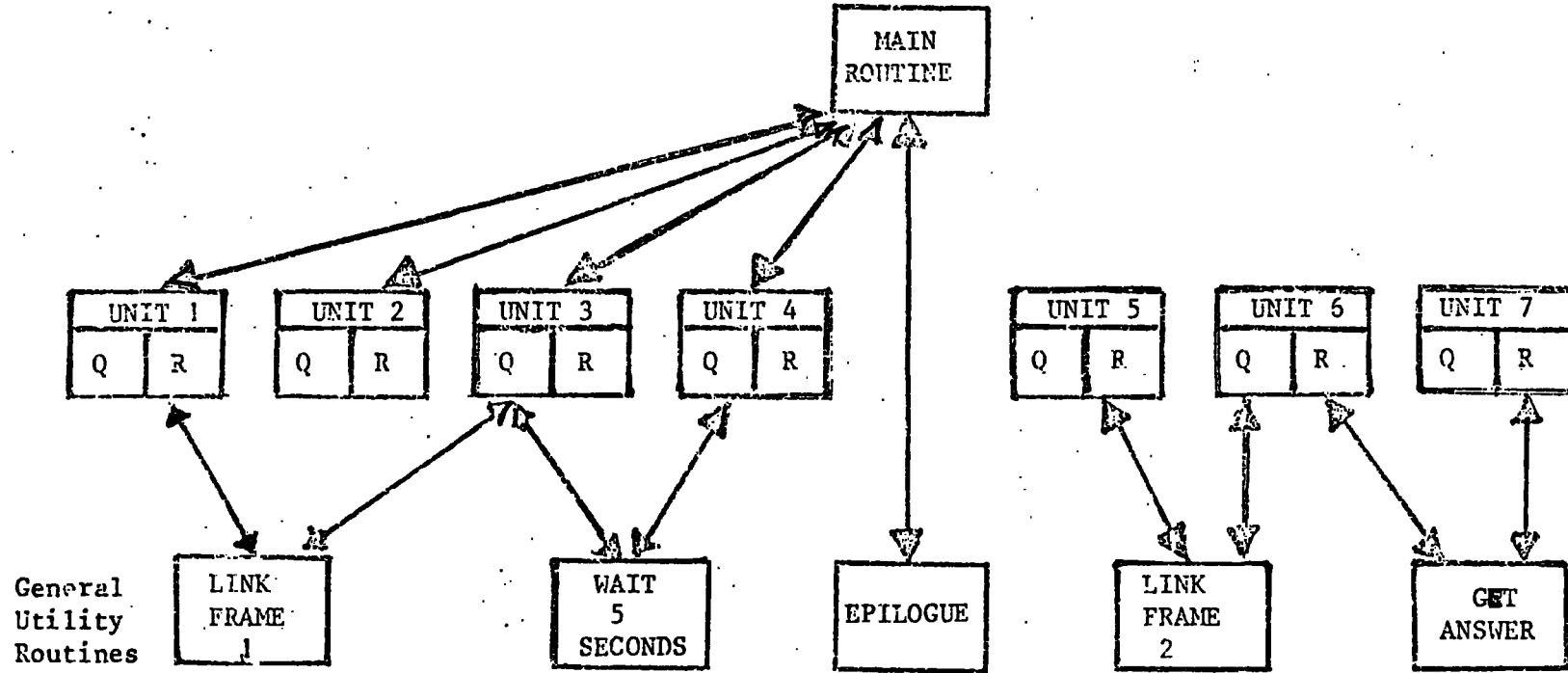

Q denotes question material

R denotes reinforcement material

Figure 6.13

General Utility Routines

an example. Figure 6.14 illustrates the microcomputer frame layout chart which presents Question No.4 to the student. Figure 6.15 lists the BASIC program to produce Frame 7A.

6.4 EVALUATION OF THE CAL EXPERIMENT

6.4.1 Introduction

The target audience for the teaching programme was originally intended to be second year Computer Science Degree students. Students undertaking this course at Teesside Polytechnic (where the experimental rig was built) were asked to volunteer to operate the system, attempt to answer the questions and, on completion, answer a questionnaire. Subsequently, some members of staff expressed an interest and the final mix of volunteers was as follows:

- 8 Second Year Computer Science Degree students
- 1 "A" Level student (from a local secondary school)
- 1 Lecturer in Computer Studies (Teesside Polytechnic)
- 1 Educational Technologist (a Senior Lecturer in Education Studies - Teesside Polytechnic)
- 2 Secondary School teachers of Communication Studies

The above people completed questionnaires which are analysed below. In addition the system was used by Mr. R.H.M. Fothergill, Head of Newcastle upon Tyne Polytechnic Educational Technology Resource Advisory Service (PETRAS).

The duration of the tests was 55 to 73 minutes although 90% were completed in under 60 minutes. A list of the performance of each volunteer who attempted the test was produced on the microcomputer printer.

BASIC Program to produce Frame 7A

```
876 PRINT "☒++HOW DOES THE USER SELECT THE PAGE"
878 PRINT "OF INFORMATION THAT HE REQUIRES TO"
880 PRINT "EXAMINE?"
882 PRINT "++++A: BY DIALLING A SPECIAL TELEPHONE"
883 PRINT "++++NUMBER"
885 PRINT "++++B: BY SELECTING A BBC OR ITV"
886 PRINT "++++CHANNEL ON THE TV SET"
889 PRINT "++++C: BY USING A REMOTE CONTROL"
891 PRINT "++++CHANNEL SELECTOR"
895 PRINT "D: BY MEANS OF A KEYBOARD"
897 PRINT "++TYPE THE LETTER THAT CORRESPONDS"
898 PRINT "TO YOUR ANSWER"
899 INPUT " +----->>V";A$
901 IF A$ = "D" THEN 913
902 IF A$ = "A" OR A$ = "B" OR A$ = "C" THEN 919
903 PRINT "☒++INVALID ANSWER"
905 PRINT "++PLEASE CHOOSE FROM THE FOLLOWING:"
907 PRINT " ++VVVA,B,C OR D"
909 PRINT " ++TRY THIS QUESTION AGAIN"
911 GOSUB 8000 : GOTO 876
913 PRINT "☒++++ WELL DONE"
915 PRINT " ++YOU ARE PERFECTLY CORRECT"
917 GOTO 921
919 PRINT "☒++++ SORRY - YOU'RE WRONG!!"
921 GOSUB 8000 : REM WAIT 5 SECONDS
      ○
      ○
      ○
      ○
      ○
```

Figure 6.15

6.42 Summary and Detailed Information obtained from Printer

Summary Information

- (1) Name
- (2) Course Code
- (3) Time for Presentation
- (4) Number of Correct Answers (out of 20)
- (5) Number of Incorrect Answers
- (6) Number of Incorrect Key-ins (that is, character/numbers keyed-in other than A, B, C or D)

Detailed Information

In addition to the above summary information, the following details of performance in answering questions numbered 1 through 20 was listed. One mark was given for each correct answer.

- (7) Time Taken. (This was for purposes of record only.
It was emphasised to each volunteer that the exercise was self-paced and not 'against the clock'.)
- (8) Number of incorrect key-ins (per question)
- (9) Mark (0 or 1)
- (10) Number of times the 'HELP' key was used (per question)
- (11) The answer keyed-in. (The single letter or the combination of letters required to answer the question)

The format of the above information obtained from the microcomputer printer is presented as Figure 6.16.

In the event of a printer not being available when tests were being undertaken, provision was made to present the above statistics on the VDU of the microcomputer.

The relevant BASIC programming statements to produce the statistics are contained in lines 8180 through 8450 of the computer program listing - see Volume II.

Typical Output from the Microcomputer Printer

```
=====
NAME: P LAMBERT
COURSE CODE: BSC2
TIME FOR PRESENTATION: 61 MINUTES
NUMBER OF CORRECT ANSWERS: 18
NUMBER OF INCORRECT ANSWERS: 2
NUMBER OF INCORRECT KEY-INS: 0

      INVALID
QUESTION  TIME  KEYINS  MARK  HELP  ANS
=====  =====
   1      22     0      1     0     C
   2      33     0      1     0     AD
   3      56     0      0     0     A
   4      21     0      1     0     D
   5      35     0      1     0     C
   6      34     0      1     0     C
   7      38     0      1     0     D
   8      28     0      1     0     A
   9      39     0      1     0     C
  10      36     0      1     0     C
  11      27     0      1     0     C
  12      26     0      1     0     B
  13      24     0      1     0     C
  14      71     0      0     0     B
  15      29     0      1     0     C
  16      37     0      1     0     AD
  17      42     0      1     0     D
  18      86     0      1     0     BCD
  19      29     0      1     0     C
  20      46     0      1     0     D
=====
```

Figure 6.16

6.43 Design of Questionnaire

The questionnaire consisted of 17 questions. The first 12 questions were based on a questionnaire recommended by a British Library Research and Development team (Chapter 2, Ref. 7).

The questions are designed to assess:

- (1) Amount of notetaking undertaken by user.
- (2) Views on amount of information presented in the time.
- (3) The pace of the information presented - at the beginning, middle and end of the presentation.
- (4) Views on the length of the presentation.
- (5) The level of interest experienced in the presentation at the beginning, middle and end.
- (6) Amount of satisfaction in being given the opportunity to see the presentation.
- (7) Views on the usefulness of the presentation.
- (8) Views on the effectiveness of the presentation as a method of learning.
- (9) The amount of difficulty experienced with the information presented.
- (10) The legibility of the slides used.
- (11) Views on whether the content of the slides supplemented the commentary.
- (12) The quality of the commentary.

To these were added the following:

- (13) Views on the ease of understanding of the questions posed by the computer.
- (14) Ease or difficulty in following instructions on the use of the equipment.
- (15) The amount of information contained in the Guidebook.
- (16) Familiarity with the subject matter before using the learning package.
- (17) Comments on how the system could be improved, including suggestions for possible application areas.

The questionnaire was completed immediately after finishing the CAL instructional course.

A sample of the questionnaire is presented in the following pages. Section A is completed only if there is no printer available to enable the final results to be printed out. Section B is completed by all students. The numbers contained in the boxes of the illustrative questionnaire represent the number of respondents answering the option concerned.

QUESTIONNAIRE

MULTI-MEDIA COMMUNICATION EXPERIMENT

Notes to be used in conjunction with the attached questionnaire.

1. Please read the following instructions carefully.
2. This booklet consists of two parts - A and B.

Part A may be omitted if a computer printout is produced during the experiment.

Part B must be completed by all candidates.
3. Follow the instructions given to you by the computer.
4. Do not write anything in this booklet until you are requested to do so.
5. If you have any problems contact the research assistant conducting the experiment.
6. Before you commence the experiment, please complete the following details:

Name: Course:

Age: . . . Nationality: College

Programme Name: "TELETEXT SYSTEMS" Date

7. Now start the CAL experiment.

TELETEXT SYSTEMS - TEST RESULTS

NAME:

COURSE CODE:

TIME FOR PRESENTATION

MINS

NO. OF CORRECT ANSWERS

NO. OF INCORRECT ANSWERS

NO. OF INCORRECT KEY-INS

QUESTION	TIME	INVALID KEY-INS	MARK	HELP REQUESTS	ANSWERS
----------	------	--------------------	------	------------------	---------

1

2

3

4

5

6

7

8

9

10

11

12

13

14

15

16

17

18

19

20

1. Did you make notes:

Frequently	1
Occasionally	1
Never	11

2. In your opinion was the amount of information presented in the time:

Too much	2
Just right	11
Too little	

3. What was your opinion of the pace at which information was presented in the beginning, middle and end sections of the presentation? (Tick one box for each section)

	<u>Beginning</u>	<u>Middle</u>	<u>End</u>
Very slow	1		
Slow	5	1	
Just right	6	8	8
Fast		3	4
Very Fast		1	1

4. Did you think the presentation was:

Too long	
Long	6
Just right	7
Short	
Too short	

5. Did you find the presentation during the beginning, middle and end sections (tick one box for each section):

	<u>Beginning</u>	<u>Middle</u>	<u>End</u>
Very boring	1		
Boring	1		
No feelings either way	4	3	3
Interesting	7	9	6
Very interesting		1	4

If you can, please explain your reasons below:

6. Are you pleased to have had the opportunity to see the presentation?

Not at all	
A little	1
Fairly	1
Much	3
Very much	8

7. How useful do you think it was to see the presentation?

Very useful	7
Fairly useful	5
No feeling either way	1
Not very useful	
Not at all useful	

If you can, please explain your reasons below:

8. Is this a good way of learning?

A very good way	3
A fairly good way	8
No feelings either way	2
Not a very good way	
A very bad way	

9. Did you understand the information presented? Was it:

Too easy	
Easy	2
About right	10
Difficult	
Too difficult	
Parts difficult	1

10. Could you see clearly what was on the slides?

Always	1
Most of the time	11
Not much of the time	1
Never	

11. In your opinion did the slides generally:

Reinforce what was said	12
Add nothing to what was said	
Distract from what was said	1

12. With regard to the commentary, was the voice:

Clear	8
Unclear	1
Easy to listen to	8
Hard to listen to	

Interesting	1
Monotonous	4
Too fast	1
Just right	8
Too slow	

13. Were the questions asked by the computer easy to understand?

Yes

12
1

No

14. Did you find the instructions on using the equipment easy to follow?

Yes

12
1

No

If your answers to the above was 'No' in either case it would help if you could explain your reasons below:

15. With regard to the information contained in the guidebook, was the amount of information:

Too much

11
2

Just right

Too little

Too easy

1
2
10

Easy

About right

16. Were you familiar with the subject matter before watching this presentation?

Yes

8
5

No

17. If you have any comments on how the system could be improved, please describe them below. Include any suggestions of possible application areas.

18. SUMMARY OF RECIPIENT RESPONSES

No. of correct answers

No. of incorrect answers

No. of invalid key-ins

COPY THIS INFORMATION FROM THE SCREEN OF THE COMPUTER (OR FROM MINI-PRINTER IF AVAILABLE)

ANSWER PROFILE

1	2	3	4	5	6	7	8	9	10	11	12	13	14	15	16	17	18	19	20	

Thank you for your co-operation in completing this questionnaire.

6.44 Questionnaire Analysis

As the total number of users amounted to only 13 people it is not suggested that the following conclusions have any statistical validity. However, they may be of interest to other researchers.

Question 1 (Notetaking)

The amount of notetaking observed was minimal. 11 out of 13 users did not take any notes. One reason for this is that each volunteer was told that he/she would be given a copy of the guidebook in appreciation of their co-operation.

Question 2 (Amount of information presented in the time)

Only 2 thought there was too much information. The remainder thought the amount was just right.

Question 3 (Pace of information presented)

Beginning: The opinions were about evenly divided.
Very slow (1), Slow (5), Just Right (6), Fast (1)

Middle: Slow (1), Just Right (8), Fast (3), Very Fast (1)

End: Just Right (8), Fast (4), Very Fast (1)

Question 4 (Length of presentation) (55 to 73 minutes)

Again, opinions were about equally divided. 6 thought the presentation was long. 7 thought it was just right.

Question 5 (Level of interest)

Beginning: Interesting (7), No feelings either way (4), Boring (1), Very boring (1)

Middle: Interesting (9), No feelings either way (3), Very interesting (1)

End: Interesting (6), Very interesting (4), No feelings either way (3)

9 of the users gave reasons for their answers to question 5. These are reproduced below:

"At the start the data shown (communications) was more simple and tended to be tedious in places. But later the data became more interesting."

"The beginning section was information I had a lot of prior knowledge of but still found interesting. The last two sections contained information I knew a bit about but it expanded my knowledge of them."

"I am interested in future uses, especially in the field of education."

"Intrinsic interest in topic. Variety of stimuli with mixed media presentation. INTERACTIVE"

"I was not as interested in the technical details as I was with the actual applications."

"At the beginning the pace of the presentation for definitions, etc., are too slow."

"The middle and end sections were interesting to me since it provided information that I had not had before, e.g. parts of a TV screen being used for engineering tests, etc."

"Anxious to know what it is all about."

"Beginning: have an insight already. Middle: interest in how they do it. End: new developments are always interesting."

Question 6 (Amount of satisfaction in being given the opportunity to see the presentation)

The amount of satisfaction expressed was: 'Very much' (8), 'Much' (3), 'A fair amount' (1), 'A little' (1).

Question 7 (Usefulness of the presentation)

The views expressed were 'Very useful' (7), 'Fairly useful' (5), 'No feeling either way' (1).

Question 8 (Effectiveness of the presentation as a method of learning)

8 thought the method was 'a fairly good way', 3 'a very good way' and 2 'no feelings either way'.

Question 9 (understanding of information presented)

1 thought the information 'was difficult in parts', 2 thought it was 'easy', and 10 thought it was 'just right'.

Question 10 (Legibility of the slides used)

In answer to the question "Could you see clearly what was on the slides?" 1 said 'always', 11 said 'most of the time', and 1 said 'not much of the time'.

(N.B. The screen was positioned beside a large window without blinds)

Question 11 (Views on whether the content of the slides supplemented the commentary)

12 thought that the slides reinforced what was said. 1 thought the slides distracted from what was said.

Question 12 (Views on the commentary)

8 thought the voice was clear and easy to listen to. 1 thought the voice unclear and hard to listen to. 8 thought the pace was 'just right', 4 thought it was monotonous, and 1 thought it was too fast.

Question 13 (Views on the ease of understanding of the questions posed by the computer)

12 users thought the questions were easy to understand. 1 thought they were not easy to understand.

Question 14 (Ease or difficulty in following instructions on the use of the equipment)

12 thought that the instructions were easy to follow. 1 thought they were not easy to follow. No reason was given in the latter case.

Question 15 (Amount of information contained in the Guidebook)

11 thought the amount of information was 'just right'. 2 expressed the opinion that there was too little information.

As regards the level of information, 10 thought it was 'just right', 2 thought it was 'easy' and 1 thought it was 'too easy'.

Question 16 (Familiarity with subject matter before watching the presentation)

8 of the users said they were familiar with the subject and 5 had no prior knowledge.

Question 17 (Comments on how the system could be improved and suggestions on possible application areas)

Suggested improvements:

1. The capability to review again slides already seen. (A random access slide projector (see Section 6.214a) provides this facility but the time available did not allow for evaluation by students.)
2. Use of two voices on the audio commentary to provide vocal variety.
3. Allowing the user to hold the slide on the screen as long as he/she wishes. (There should be no technical difficulty in meeting this requirement.)
4. Make the review of the correct answer optional to reduce the presentation time.

5. Use of pre-test and post-test questions to establish entry levels. (An experiment to achieve this requirement was subsequently undertaken - see below.)
6. Use of remedial slides instead of Guidebook.

Suggestions on possible application areas were as follows:

7. Use at Trade Fairs, exhibitions, etc., to promote products and services.
8. For career guidance and counselling.
9. Use in most information-based subject fields.
10. One user suggested that people in hospital, in prison and the physically handicapped could use the system!

6.5 COMMENTS ON SOFTWARE DESIGN

As was mentioned earlier, the program responsible for the co-ordination of peripherals, presentation of material to students and recording of responses was written in BASIC. The version used was dictated by the nature of the microcomputer used (Commodore PET) which was the only high level language available with the system. A 'data-item-name' table (correlating the names of variables with their function) and a memory allocation map (showing the line number ranges allocated to various sections of the program) are shown in Figures 6.17 and 6.18 respectively. These were found to be most useful program development aids.

6.51 Program Analysis

The program responsible for running the CAL experiment has been analysed for the purposes of comparison with other items of software that might be written. The results of the analysis are presented below:

DEVELOPMENT OF CAL SOFTWARE FOR "TELETEXT SYSTEMS"

DATA-ITEM-NAME TABLE

IDENTIFIER	FUNCTION
G\$	REPLY TO A GO MESSAGE
A\$	REPLY TO A QUESTION
NAME\$	RESPONDENT'S NAME
B\$	COURSE CODE
C\$	CORRECT RESPONSE TO A QUESTION
W1\$	INCORRECT RESPONSES TO A QUESTION
W2\$	
W3\$	
PA(7)	PAUSE POINTS AT WHICH COMPUTER TAKES OVER CONTROL FROM THE SLIDE PROJECTION EQUIPMENT; VALUES IN THIS ARRAY REPRESENT THE CUMULATIVE COUNT OF SYNCHRONISATION PULSES ON THE COMMENTRY TAPE
GO\$	REPLY TO A GO INVITATION IN A USER-DRIVEN CONTINUATION CONTEXT
NS	NUMBER OF SLIDES SHOWN AT ANY PARTICULAR TIME
NF	TOTAL NUMBER OF SLIDES TO BE SHOWN
TS	TIME AT START OF PRESENTATION
TF	TIME AT END OF PRESENTATION
KI(20)	NUMBER OF INVALID KEY-INS PER QUESTION
M(20)	MARKS ARRAY (1 FOR CORRECT AND 0 FOR INCORRECT)
AP\$(20)	ANSWER PROFILE; ACTUAL ANSWER GIVEN
TA(20)	TIME TO ANSWER A QUESTION
HR(20)	HELP REQUEST PROFILE (1 FOR HELP REQUESTED 0 OTHERWISE)
PG\$(20)	PAGE NUMBER IN GUIDE-BOOK TO WHERE THE RESPONDENT IS DIRECTED IF HELP IS REQUESTED
QS	TIME AT START OF QUESTION
QF	TIME AT END OF QUESTION
K	CURRENT QUESTION NUMBER
F1	INVALID ANSWER FLAG
F2	CORRECT/INCORRECT ANSWER FLAG
CR	NUMBER OF CORRECT ANSWERS
KS	TOTAL NUMBER OF INCORRECT KEY-INS
TP	TIME FOR PRESENTATION

Figure 6.17

DEVELOPMENT OF CAL SOFTWARE FOR "TELETEXT SYSTEMS"

STORAGE ALLOCATION MAP

MODULE NAME	LINE NUMBER ALLOCATION		FUNCTION
	START	FINISH	
MAIN ROUTINE	10	630	MAIN LOOP AND CONTROL SOFTWARE
UNIT 1	640	1000	QUESTION 1
UNIT 2	1010	2320	QUESTIONS 2,3,4
UNIT 3	2330	3300	QUESTIONS 5,6,7
UNIT 4	3310	3780	QUESTIONS 8,9
UNIT 5	3790	4130	QUESTION 10
UNIT 6	4140	5380	QUESTIONS 11,12,13,14,15
UNIT 7	5390	6950	QUESTIONS 16,17,18,19,20
WAIT-5	6960	6990	WAIT FOR 5 SECONDS
WAIT-10	7000	7040	WAIT FOR 10 SECONDS
GETANSWER	7060	7100	GET ANSWER TO QUESTION
WAITGO	7120	7220	WAIT FOR GO MESSAGE
CHECKANS	7230	7320	CHECK RESPONDENT'S REPLY
LINK-FRAME-1	7440	7480	"HERE IS A QUESTION ON WHAT YOU HAVE SEEN"
LINK-FRAME-2	7500	7550	"NOW LET'S LOOK AT SOME MORE SLIDES"
QUES-START	7570	7620	MONITOR START OF QUESTION
QUES-FINISH	7630	7680	MONITOR FINISH OF QUESTION
HELPER	7690	7850	HELP SYSTEM FOR REMEDIATION
INIT-DATA	7960	8040	INITIALISATION DATA
EPILOGUE	8050	9000	PRESENTS STATISTICS TO RESPONDENT AND PERFORMS CLOSE DOWN ROUTINES
TITLE-FRAME	9010	9390	"TELETEXT SYSTEMS" USING GRAPHICS

Figure 6.18

Number of Source Statements	= 1052	See note A
Number of Source Lines	= 929	See note B
Load size of Program	= 30,103 bytes	See note C
Total running time	= 1 hour (approx)	See note D
Development time	= 4 hours/question	See note E

Analysis of Program by Statement Type

<u>Statement Type</u>	<u>Count</u>	<u>Percentage of Total</u>
PRINT	577	54.8
ASSIGNMENT	142	13.5
GOSUB	125	11.9
REM	57	5.4
IF	49	4.6
GOTO	34	3.2
RETURN	22	2.1
INPUT	19	1.8
FOR-NEXT	11	1.0
DATA	5	0.5
POKE	4	0.4
READ	2	0.2
DIM	1	0.1
ON	1	0.1
OPEN	1	0.1
CLOSE	1	0.1
	<u>1052</u>	<u>99.8%</u>

Note A

This total does not include the statements that form part of an IF statement, similarly, the FOR NEXT combination is treated as one single statement. However, because of the small number of IF and FOR statements, any alternative method of treatment should not significantly affect the results.

Note B

It must be emphasised that the number of source lines does not correspond with the total number of BASIC program statements since many of the source lines contain three or more statements.

Note C

The size of the program was determined by subtracting the value of the function reference FRE(0) after loading the program from the corresponding value obtained before loading the program. The results obtained were as follows:

Value of FRE(0) before program loading	=	31310 bytes
Value of FRE(0) after program loading	=	<u>1207</u> bytes
		30103 bytes

Note D

The total running time of the program will obviously depend upon the student's progress - how long he spends reading a question, how long he takes to answer, whether use of the help facility is requested, how long the student spends on the remediation material and so on. Some details of actual time measurements have been presented earlier.

Note E

The software development figure quoted is in no way an accurate figure. Details were not accurately recorded because in this first experiment the objective was to produce some software for use rather than accurately measure the rate at which it could be produced. This is a very important metric which will need to be given more attention in subsequent experiments of a CAL nature.

The development time could be broken down into three broad categories:

- (1) Initial learning period to gain familiarity with the computer system and the particular programming language used. In the case of the author, this amounted to about two-three hours 'playing' with the system. For the novice this figure could be substantially higher.
- (2) The amount of time spent coding the frames associated with a question and then testing them. This averaged about four hours per question.

- (3) The figure reported does not include "research" time, that is, the amount of time spent trying to find out how to do something or how to overcome a particular problem.

An analysis of the program statistics indicates a very high proportion of PRINT statements. The character string literals associated with these require storage space and in most cases are used only once during a course of instruction. From this point of view the program is extremely wasteful of storage. Unfortunately, this approach of coding the print literals into the program has to be used when random access storage devices are not available - as was the case when program development for this experiment commenced.

6.52 Future Design Recommendations

If the system was to be re-designed, taking into account the availability of a random access storage facility, then a much better solution to the software problem could have been formulated in terms of a random access file having the following type of logical structure:

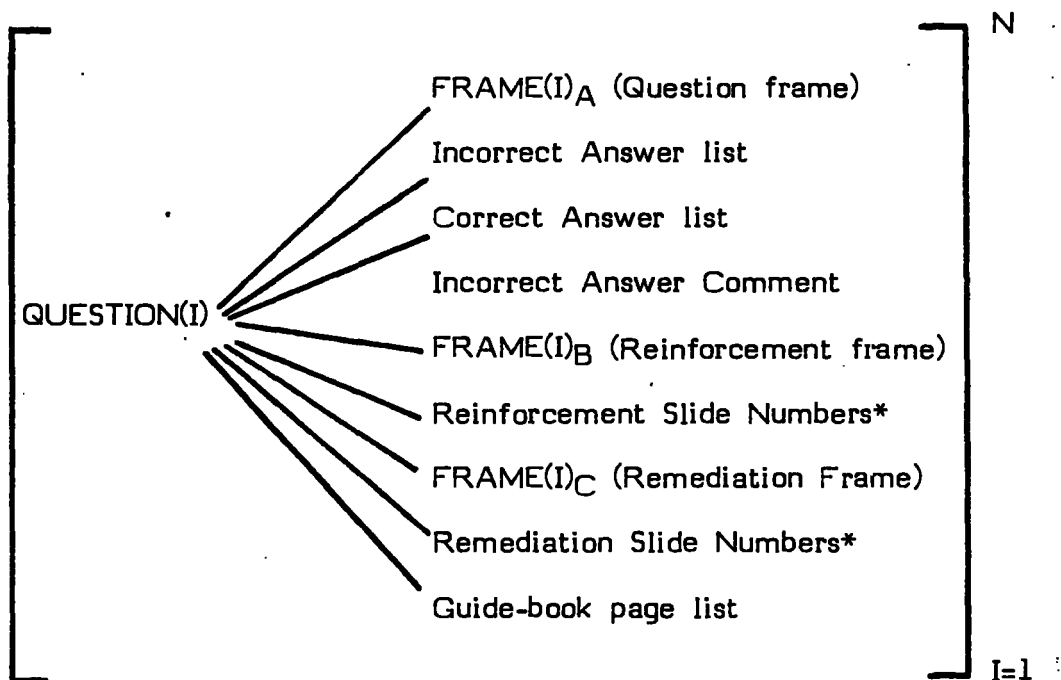

This structure of course implies that the main stream material during the course of instruction will be accessed sequentially. If this is not the case then an additional element would need to be included in the above structure to enable the order of presentation of main stream slides to be represented. Naturally, this assumes (as do the items flagged with an * above) the availability of a random access slide projector. Should this not be the case then a suitably prepared guide-book would still be required for reinforcement and remediation material.

Using a highly structured file similar to that described above would mean that the program could now be made much simpler and its size reduced quite substantially. A further discussion of this approach will be presented later when the idea of a data base system for frame management is investigated and a simple design formulated (see Chapter 7).

6.6 CONCLUSIONS

In the previous experiment the questionnaire that was presented to those participating in the CAL experiment was capable only of assessing the respondent's views on the method of presentation and the overall acceptability of the system. Of equal importance to these considerations is that of the effectiveness of the presentation. In other words, how much does the student actually learn as a result of interaction with the system? In order to answer this type of question it is necessary to design and stage suitable pre-tests and post-tests which enable one to assess how much of the information on the subject presented is retained by the student. This type of testing provides a suitable application for the microcomputer driven random access slide projector previously described in Section 6.214(a). The overall strategy for this experiment is described below.

6.61 Strategy for Pre-test and Post-test Questioning

The method adopted was as follows:

- (1) Preparation of a data bank of material on the subject of "Teletext Systems"
- (2) Ask participants some randomly selected questions from the data bank and record the answers. This constitutes the pre-test.
- (3) Present the participant with the course of instruction on "Teletext Systems" described in the last experiment.
- (4) Ask the participant some randomly selected questions from the data bank and record the answers. This constitutes the post-test.
- (5) Compare the results of steps (4) and (2) and see if there is any significant difference.
- (6) Repeat for next member of sample population.

Implementing the above strategy revealed the following problems:

- (a) Ensuring that two different sequences of random numbers are produced for each of the participants. (To ensure that the pre-test and post-test do not ask the same questions in the same order.)
- (b) Ensuring that the data bank of material for the pre-test and post-test is related to the instructional material presented in the previous experiment.
- (c) Timing considerations with respect to the elapsed time between the operations (2), (3) and (4) above.

For (a) above a program was written to produce two sets of random numbers; one set for the pre-test and the other set for

the post-test. Unfortunately, the available time did not permit the use of these programs.

For (b), a total of 80 slides was produced as compared with 60 in the teaching programme. This was to provide a greater variability of questions within the topic areas to test the user's understanding of the subject at pre-test and post-test stages. The mix of slides is described in 6.62 below.

For (c), the intention was to give a pre-test one day, following this the next day with the teaching programme. The interval between the teaching programme and the post-test would, however, have been longer - up to one week after taking the teaching programme. The purpose was to test the amount of retention of information over different periods. Unfortunately, however, the time available did not permit these experiments to be concluded.

6.62 Preparation of Data Bank of Material

The RASP carousel holds a maximum of eighty 35mm slides. It was decided to use the full capacity of the slide magazine to provide the visual material for the pre-test/post-test questions. The slides were distributed over the topics within the subject "Teletext Systems" as follows:

<u>Description</u>	<u>No. of slides</u>
<u>Teletext Systems - General</u> Data organisation, use of colour, editing operations, use of graphics	22
<u>Broadcast Teletext Systems</u> Examples from CEEFAX and ORACLE teletext systems	16
<u>Viewdata Systems</u> Organisation of viewdata systems, role of information providers, examples from PRESTEL, business and other types of terminals used	26
<u>Mixed Media Systems</u> Illustrations from the PLATO and CYCLOPS systems showing various applications and equipment used	16

Brief descriptions of the slides, the manner in which they were distributed throughout the programme and the multiple choice questions devised for each slide are presented in Volume II.

6.63 Preparation of Microcomputer Program

A microcomputer frame layout chart was prepared for each question and multiple choice answers in the manner described in Section 6.35. The information contained on these charts was transcribed to flexible disk using special programs written for the PET by Barker (Ref. 2). Programs were also available to enable the random recall and updating of these frames. These programs thus provided data capture and data management facilities. A further program was designed which enabled simple user interaction with the system.

Entering any number within the range 1-80 on the keyboard of the Commodore PET caused the carousel on the RASP to index to the slide number selected and project the slide on a back projection screen. Simultaneously, the multiple choice question relating to the particular slide appeared on the microcomputer screen. The software was extended to produce a predefined number of slides (in most cases 10) in a random fashion. The results of the experiment were demonstrated to several educational technologists who had participated in earlier experiments. Unfortunately, time did not permit the system to be evaluated using the RASP for pre-test/post-test questions.

6.64 Author's View

Development of a multi-media CAL package of the type described has demonstrated (albeit with a very small sample of users) that a low-cost microcomputer could be connected to standard audio-visual equipment. The opinions of the users have already been described and clearly refinements are desirable and feasible. However, the consensus view was that the experiments demonstrated a worthwhile teaching tool that could be afforded by most schools and colleges.

While the experiments were in progress the training manager of a large organisation expressed an interest in its use. Subsequently a copy of the CAL equipment and software (slides, audiocassette and computer program) was produced for use in an industrial training environment. It is hoped that at some future date its usefulness will be assessed.

Production of the multi-media CAL package was a very time consuming exercise. The skills required include:

1. Electronic expertise for interfacing peripherals.
2. Computer programming.
3. Script writing and preparation of an audio commentary.
4. Production of 35mm slides using a variety of photographic techniques.
5. Study of current developments and literature on the subject.

The view is held that team effort is essential to a project of this type. While most individual teachers or instructors have the qualities required to be an author (See Section 5.52), few have the inclination or the time to get involved in all the above activities. Most of the computer based instructional material that has been produced to date has been "hand coded" by CAL authors having an appropriate background in programming and software development methodology. These prerequisites are a severe disadvantage to the effective utilisation of microcomputer based methods in education. In particular this applies in subject areas other than mathematics, computer science and electronic/electrical engineering. Furthermore, the development of proven instructional software by this technique is time consuming and thus costly. There is likely to be duplication of effort unless a team approach which is centrally coordinated is adopted.

In the next chapter the further research contemplated to exploit the role of the microcomputer is outlined. The future of CAL on mainframe and minicomputers and the probable impact of viewdata systems is also discussed.

REFERENCES

- (1) Small Systems Engineering Ltd., 62 New Cavendish Street, London W1N 7LR, IEEE-488 Unidirectional Serial Interface Type C.
- (2) Barker, P.G. & Yeates, H., Experiments in Man-Machine Interaction, an Interactive Systems Group publication, April 1980.
- (3) Kodak Audiovisual Products, Kodak 'Carousel' S-RA2000 Projector, PD1727/73LF10/10-78.
- (4) Kodak, Special Application of Kodak Carousel S-RA2000 Projectors 93024-N-6-78 SCH.

CHAPTER 7

CURRENT TRENDS AND FUTURE PROSPECTS FOR INSTRUCTIONAL USES OF THE COMPUTER

- 7.1 Introduction
- 7.2 The Future of CAL on Large Computers
- 7.3 The Future of CAL on Minicomputers
- 7.4 The Future of Micro CAL Applications
- 7.5 The Future Impact of Viewdata
 - 7.51 Introduction
 - 7.52 Information Retrieval for Education
 - 7.53 CAL Applications on Viewdata
 - 7.54 Development of Text Recording Units for Viewdata/Teletext
 - 7.55 Projected Uses of Viewdata for Distance Teaching
 - 7.57 Learning Outside Educational Institutions
 - 7.57 Home Computing and Viewdata
 - 7.58 Conclusion
- 7.6 Media Considerations
 - 7.61 Introduction
 - 7.62 The Multi-media Capability of Videodisks
 - 7.63 Development of Intelligent Videodisks
 - 7.64 The Economics of Media Considerations
- 7.7 Convergence of Interests - The Need for Total Integration
 - 7.71 Introduction
 - 7.72 Definition of a Multi-media Data Base
 - 7.73 Types of Information contained in the Data Base
 - 7.74 'DATALAND' - An Example of a Multi-media Data Base
 - 7.75 The Need for the Multi-media Data Base to be Dynamic
 - 7.76 The Nature of the Message Creation Process
 - 7.77 The Role of the Computer
 - 7.78 Interactions arising in a Multi-media System
 - 7.79 The Data Base Processor
- 7.8 Problems of Integration
- 7.9 Conclusion
 - 7.91 Courseware Problems
 - 7.92 Probable Developments of CAL in Higher Education

CHAPTER 7

CURRENT TRENDS AND FUTURE PROSPECTS FOR INSTRUCTIONAL USES OF THE COMPUTER

7.1 INTRODUCTION

As computer technology advances it opens new opportunities and new capabilities for education and training. It has previously been shown that the current state of technology is already adequate to permit a wide range of instructional uses, and anticipated cost trends will expand that range even further. Hardware trends that are likely to affect the future of instructional computing include the expanding applications of both individual mini/microcomputers and time-shared large computers. This will be complemented by improvements in the cost and capability of terminals and growing telecommunications capacity. This chapter will review the above trends, the probable impact of viewdata, and will finally discuss the need for total integration and the associated problems of establishing multi-media data base systems.

7.2 THE FUTURE OF CAL ON LARGE COMPUTERS

There are three practical advantages of large machines. First, they can be used to solve very large problems that require high computational speed, extensive storage, and very long programs. Second, they can support the acquisition, maintenance and use of large data files. Levien and Blackwell (Ref. 1) suggest that such files would be necessary for CAL applications in the social sciences and humanities. Third, they can support a wide range of programming languages and services, including some requiring very large and computationally demanding translating programs.

A fourth advantage is the possibility of developing and storing a library of widely usable programs in each large computer. This has potential advantages when the computer is shared by many users having similar needs, as when it is employed on a time-sharing basis by firms in the same industry or specialists in the same discipline. The usual problems of standardisation are avoided, since everyone is using the shared program on the same machine.

The economic advantage of large computers derives from the lower cost per computation and per bit stored that results from economies of scale. Where sufficient demand exists to make full use of a larger machine, it is economically desirable to do so. According to Levien (Chapter 3, Ref. 8) this has been one of the factors favouring the development of large time-sharing services. However, where demand comes from many independent, geographically dispersed sources, the costs of communications and overheads (especially the execution and allocation of switching programs) consume some of the prospective benefits. Future trends in large machines are expected to include the following:

- (1) Continued cost reductions.
- (2) Increased adaptation to the requirements of large-scale time sharing (especially with regard to the ability to perform several tasks at once).
- (3) Growth in the size of their high speed memories.
- (4) Greater adaptability to a variety of different tasks through changes in internal machine languages.

Item (4) above is possible by use of a technique called microprogramming. This is a set of micro instructions which together define a specific hardware function independently of application software or operating system control. For example, a microprogram may be used to effect code conversion or data input.

7.3 THE FUTURE OF CAL ON MINICOMPUTERS

The overriding advantage of minicomputers is that they can either operate as individual machines or can communicate with one another and with large central computers. The development of small size, low-cost, general purpose computers has been a consequence of the invention of integrated circuits. Such circuits make it possible to contain the circuitry of contemporary computers in as little as 1 cubic foot and at a small price (£2000-3000). Moreover, these reductions in size and cost have not been accompanied by commensurate reductions in computational capacity. Some minicomputers are capable of 1 million additions per second. Generally, minicomputers differ from full size systems in word length (typically 12 to 18 bits instead of 32 to 60 bits). Minicomputers have smaller instruction sets and less complex system software. While the total cost of the minicomputer is relatively low, its average cost per computation is high compared with that of an efficiently operated large computer. Nevertheless, at the prices prevailing now and expected in the future, the growth of minicomputer use can be expected to continue. Many users are willing to trade an increase in computational cost for the ease of access, reliability and simplicity of a minicomputer. There is also the freedom from the costs and difficulties sometimes experienced with telecommunications. Unlike large computers, widely distributed minicomputers cannot have associated staffs of system and application programmers at each installation. Their salaries would negate the economies of the small machine. Until recently minicomputers have been generally sold to scientific or other specialist users, who can do their own programming, or for tasks in which only one or a small number of programs were required. Now with the dramatic drop in price of integrated circuits, minicomputers can now be equipped with input/output devices that read and write data on magnetic tape cassettes of the type used for audio recording. Application programs which can hold tens of thousands of words can be stored on such cassettes which may be bought by or rented to users.

Minicomputers can be expected to grow rapidly in economy and effectiveness in the future. A major feature of this development will be the growth of application program libraries available on cassette or disk. In the past few years minicomputers have been marketed which can communicate with large mainframe computers and each other. The implications for CAL are that when students using one system for problem solving need the resources of another, they have it virtually at their fingertips. Data compiled and maintained on one computer system is accessible to other computers in the network.

The advance in integrated circuit and storage technologies have also stimulated the computer terminal manufacturers and the last few years has been a period of rapid innovation. One major trend will be to upgrade familiar domestic communication devices (typewriter, television and telephone) to make them computer terminals. These will combine the computer (mini and eventually micro) with terminals that are able to operate either alone or in communication with large computers. Some current models of minicomputers are very powerful indeed. By increasing circuit density and reducing power requirements through silicon on sapphire 'chip' technology one manufacturer now produces 'mini' computers with memory sizes ranging up to 2 million bytes. Perhaps, 'minicomputer' is now a misnomer. The only thing 'mini' about them is their price. For example, the current price of this minicomputer manufacturer's largest machine - the one with over 2 megabytes of memory - is one-quarter of what it was five years ago. An example of the scope of minicomputers for CAL in a time-sharing environment is given below.

7.31 An Example of a Minicomputer CAL application

Combining educational resources can provide some very important benefits. Schools and colleges in Northern New Jersey, USA, have formed an Instructional Computer Co-operative (ICC). The system uses two Hewlett-Packard HP-2000 computer systems and has been operating since 1972 (Ref. 2). These systems provide all the educational computer services to 35 member schools. The schools subscribe to the service by contracting with Wayne, New Jersey, Public Schools ICC. This organisation has the task of

satisfying the educational computing needs of the schools and managing the computer facilities. Each HP-2000 system can accommodate up to 32 user terminals simultaneously. All users interact with the system via the BASIC programming language. The system was first used to teach mathematics. However, the variety of uses has grown beyond this. The equipment is now used for general problem-solving in many subject areas. The author language used by the HP system is called the Instructional Dialogue Facility (IDF). This author language has been designed specifically for teachers who are not computer specialists. The philosophy is that the computer system should handle the programming and let the teacher concentrate on the instructional material. For instance, a history teacher who wishes to write a lesson sits at a computer terminal. Using an IDF program he quickly constructs a lesson by answering such questions as:

"WHAT QUESTION DO YOU WANT TO ASK?"

The teacher responds:

"Who was the first Prime Minister to serve
under King George III?"

The system then responds:

"WHAT IS THE CORRECT ANSWER?"

Teacher: "Wapole"

This process continues until the complete lesson is developed.

The teacher can stop at any time and go back, if desired, to modify portions of the lesson. Once the lesson is entered in the computer it is immediately available for student use at terminals. The system carefully records the results. Using another IDF program the teacher can analyse the results, either of a single student or of a group.

The equipment can simultaneously provide drill and practice, general problem-solving capability and simulation exercises for a group of students. Since no operators are required the systems normally operate 24 hours a day, 7 days a week. Thus students and faculty members can use the systems during the day, overnight and on weekends.

The educational consortium concept is possible because of the versatility of modern minicomputer systems. For example, the HP-2000 provides remote job entry to IBM and Control Data computers. The educational consortium will help individual schools in other ways. Educational programs are pooled by the members of the consortium and in the USA there are extensive libraries of educational programs which have been contributed by member schools.

Even the multi-media CAL system PLATO can now be reproduced on a minicomputer system (Webster, 1980, Ref. 3). An organisation called Modcomp who market the 'Classic' range of minicomputers introduced the system to small organisations with limited resources in the USA in 1979. The development work for the system was undertaken at the University of Illinois. While it has many of the features of PLATO, the 'SIMPLER' system (as it has been called) can be implemented at a fraction of the cost of PLATO. Each system can support up to 32 users simultaneously. The initial courses being offered include language tuition, a basic skills and further training course for medical staff, and a range of courses for the technician.

From the evidence currently available, decentralised minicomputer systems will undoubtedly have a place in future CAL developments. The power of the minicomputer has expanded to the point where these machines overlap some large mainframe models in capability. As a result, the line separating minicomputers from large conventional general purpose computers is indistinct.

7.4 THE FUTURE OF MICRO CAL APPLICATIONS

The Council for Educational Technology suggested in 1978 (Chapter 5, Ref. 14) that, as with previous technological developments, education and training will need to make use of microelectronic systems and devices which have been developed for wide domestic and commercial markets. In the last three years since the

introduction of the low cost microcomputer into the United Kingdom, hundreds of schools and colleges have purchased these machines. Reference has previously been made (Section 4.73) to the use of microcomputers in education and training. This chapter will discuss the reasons for the impact of microcomputers on CAL.

While numerous examples of micro CAL applications can be quoted, the fact remains that the use of the computer in the classroom is still largely limited to 'the converted' in both industrial training and education. Some believe that the microcomputer might provide the means by which the minority will be changed to a majority. Before attempting to suggest reasons which could bring about this change, the situation which existed before low-cost microcomputers appeared on the scene will be examined. Resistance to CAL has been widely documented and some of the reasons for teachers and instructors not wanting to get involved are given below:

- (1) Most schools possess printing terminals from which video output is not possible. The use of CAL in demonstration mode is thus severely restricted to individuals or small groups. At best this can only be an adjunct to, rather than an integral part of, a lesson.
- (2) Teletype terminals of the type usually encountered in schools are usually noisy and print slowly.
- (3) Such terminals are not portable. This is a great inconvenience when a lesson is held in a classroom some distance away from the terminal.
- (4) Telephone links between a terminal and a mainframe computer can be expensive. Noise on the line quite often produces spurious characters in the output.
- (5) If the programs or the system malfunctions in any way from a centrally controlled computer, this can be frustrating and awkward for the teacher during a CAL demonstration.

- (6) When a time sharing system is being used, it is not unusual for response times to be very long during peak periods of use.
- (7) School terminals rarely possess graphics facilities. Thus students are deprived of the most stimulating and flexible aspects of CAL.

The use of microcomputers can alleviate all of these problems to some extent:

- (1) Video output from a microcomputer is a standard feature.
- (2) Relatively cheap printers can be purchased for use in conjunction with a microcomputer. They are both quieter and faster than teletypes.
- (3) A microcomputer system is completely portable.
- (4) As a microcomputer does not require a telephone link, there are no call charges and no spurious characters in the output due to noise. After the initial capital investment a microcomputer costs virtually nothing to run. The only significant expense is the cost of cassette tapes, flexible disks and maintenance.
- (5) It is not possible for a microcomputer to malfunction in the same way that a mainframe system can.
- (6) The response time of a microcomputer is constant in the sense that it cannot be affected by other users.
- (7) Microcomputers have made it possible to consider the use of graphics seriously for the first time in the development of CAL material for use in schools.
- (8) As discussed in previous chapters, a range of other media from tape recorders to television sets can be interfaced with microcomputers at low cost.

There are some disadvantages to using microcomputers. Cassette

based microcomputers are very slow in loading CAL programs as was discovered during the experiments discussed in the last chapter. This problem can be overcome by using flexible disk drives. However, at the moment this item of equipment costs as much as the microcomputer.

The low resolution graphics commonly available restrict the quality and type of graphical output possible. It is anticipated that medium and high resolution graphics will eventually become available and this restriction will ease. Better resolution may, however, result in slower response times.

Problems to do with the availability of microcomputer software seem certain to increase as a growing number of users are faced with the task of developing and maintaining a library of CAL programs. There are two basic approaches to overcoming these problems:

- (A) Make sharing and dissemination of resources easier.
- (B) Make development of resources easier.

Barker (Ref. 21) has proposed a design for a multi-media learning centre that is able to communicate with a large number of remote data bases containing stored educational resources. Here, the instructional material to be used in a teaching session is transmitted from a data base held on a remote machine to the microcomputer that forms the basis of the learning centre. Obviously, this approach is based upon (A) above.

The alternative approach, mode (B) above, has also been proposed (Barker, Ref. 22). This involves the design of an author language suitable for use on a microcomputer and which is able to accommodate the use of multi-media resources. Large machine program development facilities would be used wherever possible and appropriate. This would enable the user to:

- (a) enter 'frames' of material into the computer system (as in the example discussed in 7.31),

- (b) test previously stored frames,
- (c) recall and edit stored frames,
- (d) link frames of information together to form a coherent course of instruction, and,
- (e) link frames of computer based information with other instructional resources. These could include such multi-media resources as slides, videotapes and tape recordings.

Another software development envisaged by Barker is the design of suitable cross-translators. This would enable the program developed for, say, the Commodore 'PET' to be used on other popular microcomputers. To maximise the portability of the package, the development work would be undertaken in BASIC to ANSI X332 specifications.

7.5 THE FUTURE IMPACT OF VIEWDATA

7.51 Introduction

Viewdata is a new computer based information and communications medium intended to provide a nationwide service to both the general public and the professional community. Details of Viewdata and other teletext systems are described elsewhere - see "Guidebook to Teletext Systems", Volume II. However, a brief description is given here since this chapter is concerned with the future impact of this new communication medium on education and training.

The Viewdata system was developed by the UK Post Office Telecommunications Department to be both economical and easy to use. Essentially the system consists of the following components:

- (a) a low-cost, robust and reliable terminal based upon the domestic TV receiver,
- (b) a set of interconnected computers and data bases, and
- (c) the UK dial-up telephone network.

Access to the information stored on the Viewdata data base is achieved by making a local telephone call over the public network. The information is structured in the form of a tree which allows the user to select a given 'page' of information in a straightforward and natural manner. The service will provide access through a special TV set in home or office, to eventually hundreds of thousands of pages of information. For use in the office these will contain, for example, information on share prices, company information and Government statistics. Pages for home use will contain recipes, jokes and games, food prices, theatre reviews and so on. The impact of microelectronics is recognisable in making ordinary things easier to use, cheaper and more reliable (for example, automatic petrol pumps, watches, clocks, and calculators). The technology will also increase the versatility of the telephone, the television set and the computer. These developments in commercial and domestic life will have an impact on teaching and learning methods. In the long term it is expected that the effect of computer related information provision will be as far reaching on the education system as was the development of the printed word.

The UK Viewdata service has been called PRESTEL as other viewdata services are now operating in various other countries. PRESTEL differs from the broadcast teletext information services called CEEFAX and ORACLE in that its capacity for information is potentially unlimited. The maximum waiting time for the requested page of information is only two seconds. Probably the most important feature is that it is interactive. The interactive capability enables users to send and receive messages, to participate in instruction and use calculating services.

There are two basic features of the Viewdata system that will have an impact on education. These are:

- (1) The easy classification and access to large amounts of information.
- (2) The ability to direct the future outcome of the system through the interactive capability.

Information retrieval is the natural role of Viewdata systems. The interactive capabilities of Viewdata can be expected to exploit this role. The significance of these two features and the expected impact on CAL is the subject of this chapter.

7.52 Information Retrieval for Education

The following information retrieval areas for educational use have been suggested by Fedida and Dew (1978, Ref. 4):

- (1) Information and Education,
- (2) Dissemination of Knowledge (both in schools and colleges and in the home),
- (3) Information that assists in the Administration of Education.

These are discussed, in turn, below.

(1) Information and Education

Here the amount of available information is very large but will quite easily be accommodated on the Viewdata system on a regional basis. Among the topics likely to be required are the following:

- What courses are available and where?
- Qualifications required to take a course.
- Course descriptions.
- Recommended reading material.
- Career advice.
- Sources of more detailed information

(2) Dissemination of Knowledge

Information on various subjects could be stored on the data bases and Viewdata could be the first reference point for general and specialised knowledge enquiries. There is no reason why teachers could not update course material on current topics being taught, which could then be accessed throughout the teaching programme. This approach to reference information could be adopted at all levels of information from primary school to university. The key to its success would be the provision of well structured material which is simple to access and worth using. However, information providers already include the Open University, Middlesex Polytechnic and the Council for Educational Technology. It is expected that the present high standards will be maintained.

(3) Information that assists in the Administration of Education

Information such as student records, course statistics, examination marks and timetables could be entered in the Viewdata system and be easily updated. The advantages of using Viewdata in this area are that information is constantly available in a classified form from any location, coupled with a cheaper access to statistics which can be kept up-to-date.

7.53 CAL Applications on Viewdata

The potential for CAL applications has already been discussed in Section 5.64 which referred to the experimental work at the Post Office Research Establishment at Martlesham Heath. This can be expected to lead to a system of program directories and exchanges envisaged by the Council for Educational Technology (CET) in 1978 (Chapter 5, Ref. 14). Establishment of these would both reduce the expenditure of effort on programming by sharing them among users. New entrants to the field of CAL would have an opportunity to try the method without having to acquire programming skill as a prerequisite. The provision of telesoftware by the UK Broadcasting Authorities was discussed earlier (see Section 5.54). It is still in the experimental stage but the Independent Broadcasting Authority announced in February 1980 (Ref. 5) that the service would be free.

This facility will allow the user to have a question-and-answer relationship with the pages of text on the TV screen. By pressing buttons on a key-pad the viewer will be able to follow a programmed sequence of pages - rather like a self paced learning machine. The IBA intend to offer to schools, in addition to television programmes, this selective kind of text-learning package. The IBA is currently involved with Mullard in a joint research project to develop the hardware. It is anticipated that a telesoftware facility will add only a modest amount to the cost of a teletext receiver when in mass production.

7.54 Development of Text Recording Units for Viewdata/Teletext

According to Wood (1979, Ref. 6) it is possible to record the electronic signals of PRESTEL and Teletext on a modified audio tape-recorder. He suggests that up to three and a half thousand teletext pages could be recorded on a single C120 cassette. This means that one shelf of audio cassettes of this size could carry an enormous volume of text. The development of combined Teletext/PRESTEL/text recording units is currently being undertaken by several manufacturers. It is suggested that most schools should have at least one of these units within the next five to ten years.

7.55 Projected Uses of Viewdata for Distance Teaching

In Canada an interactive viewdata system called Telidon is operational. This system relates much more to computing and graphics than to the mass market. A projected use of Telidon by the University of Victoria was announced in July 1980 (Ref. 7). The intention is that students sitting at home in remote areas of Canada, thousands of miles from the University, will receive teaching material in the form of diagrams and messages on their Telidon display screens. The material would be stored in computers at the University, to which the students would have access via telecommunication lines. The project is to cost £250,000 in software and terminals and is expected to be operational within five years.

A similar distance learning project has been proposed for the use of PRESTEL to provide education for children in the remote Highlands and Islands of Scotland (Ref. 8). Stirling University, which specialises in the social problems of Highlands and Islands education, will be responsible for this EEC-funded project.

7.56 Learning outside Educational Institutions

The expected penetration of teletext and viewdata systems into homes, offices, public libraries, museums, citizens' advice bureaux, post offices and other public places will lead to an unprecedented increase in 'learning' situations. Much learning depends on finding out and organising relevant information. Many learners (through their experience of individual learning methods in school or college) will be able to organise information from the above sources. This development will lead to a great deal of educational activity, especially for adults.

7.57 Home Computing and Viewdata

In the USA there is a small but fast-growing market for the so-called home computer, and this trend is being followed in the UK. The teletext-viewdata receiver and the home computer have at least one thing in common: they both provide a display of text on the TV screen. One big difference is the way this text is derived. In viewdata, text and simple diagrams are accessed from a remote computer. For the home computer, all text must be entered manually through the keyboard or derived from prerecorded cassettes. The home computer therefore needs a full alphanumeric keyboard, while the viewdata terminal, in its simplest form, needs only a keypad.

Viewdata and the home computer may be seen as complementary. The home computer is suitable for personal information such as a diary, personal accounts and running programs. The use of a viewdata terminal, on the other hand, will enable access to up-to-date information from the remote computer, but the user will not be able to store his own information locally.

A combination of the benefits of both would seem a logical step leading to the so-called intelligent information centre. This would use the public telephone network and broadcast teletext for the access of information and external communication.

Such an experimental information centre is being developed at Philips Research Laboratories according to Turner (1979, Ref. 9). It is called MICTERM-2 which is based on the standard teletext/viewdata display format with the addition of a microprocessor and extra memory enabling the investigation of facilities required in any future home information centre.

MICTERM-2 provides a number of functions in which the user may:

- (1) access information by telephone from a viewdata computer,
- (2) store up to three pages and an application program in the internal memory,
- (3) store and retrieve information and programs on an automatically controlled audio cassette recorder,
- (4) compose and edit messages on the screen,
- (5) send messages via the telephone network, and
- (6) load and run special application programs.

These functions are controlled by the microprocessor according to a program stored permanently in read only memory. The required function is selected from a keypad which may comprise numbers with * and # - the 12 keys required for viewdata. In addition there are keys labelled MENU and NEWPAGE which are used for controlling the terminal. By keying MENU, the available functions are displayed on the screen as a menu. This comprises seven different functions, any of which may be selected by keying the corresponding numeral. These functions are briefly described below:

- (1) VIEWDATA mode which allows the user to select and receive information from the telephone line and display it on the screen.

- (2) CASSETTE mode in which the user can access a page on the cassette by keying in its position.
- (3) PROGRAM mode which starts a home computing program.
- (4) COMPOSE mode in which the user can type directly on to the screen.
- (5) RECORD mode for recording a displayed page on cassette.
- (6) SEND mode for transmitting the displayed message via the modem (modulator/demodulator) and the telephone network.
- (7) STOP mode which cancels all other modes.

In addition to the menu, the display includes a 25th row which is used for status messages to the user. The NEWPAGE key is used to select a new page for display on the screen. Successive keying of NEWPAGE will rotate the three pages stored in the memory.

The built-in cassette recorder means that pages of information can be accessed quickly from viewdata and recorded, reducing the cost of the phone call. Pages can then be browsed through at a later date. A standard C60 audio cassette can store about 300 pages of viewdata with 150 pages on each side. Using an ordinary cassette recorder it would be very difficult to access any one page at random. However, the use of a built-in cassette recorder with automatic microprocessor control means that pages can be accessed quickly and accurately. This is done via a position counter displayed on the screen. Pages can therefore be recorded or played back from any position on the tape by keying in the appropriate number.

Several manufacturers of personal computers are currently seeking approval from the British Post Office for PRESTEL interfaces. The range of peripherals which can be supported is illustrated in Figure 7.1.

RANGE OF PERIPHERALS WHICH CAN BE SUPPORTED BY PERSONAL COMPUTERS

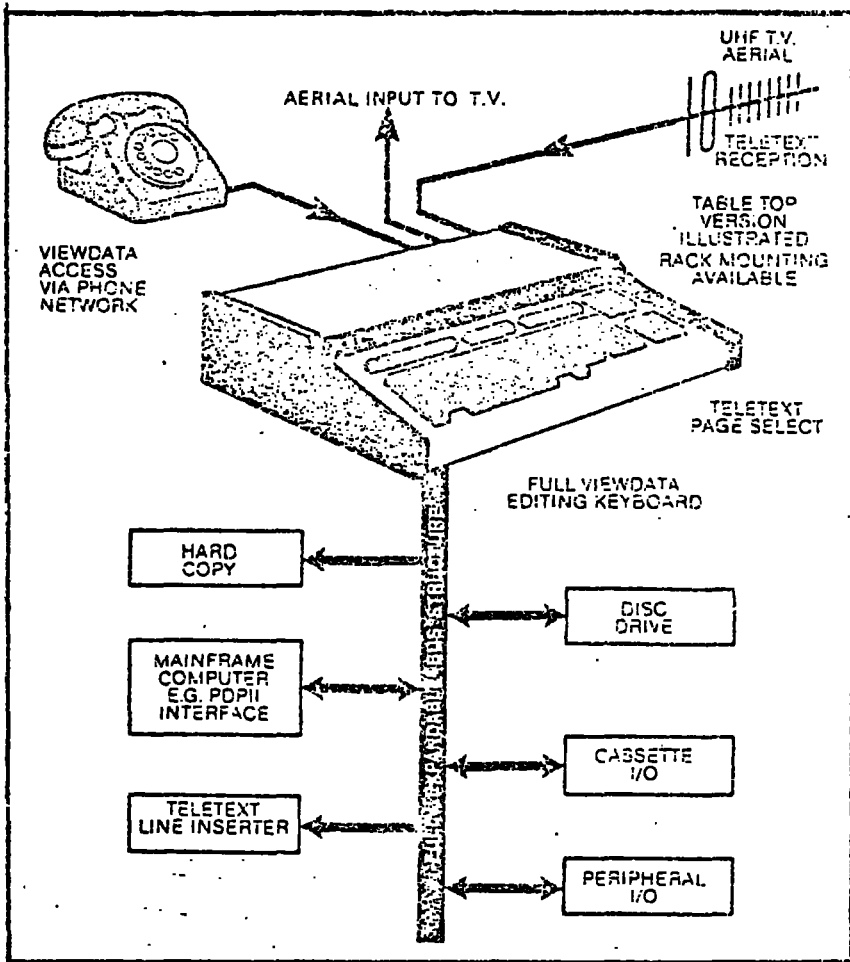

Figure 7.1

7.58 Conclusion

The domestic television receiver will become increasingly more versatile. The circuits already being produced to permit their use for teletext and viewdata services could lead to their serving as receivers for a variety of data transmission systems via telephone lines.

The use of the TV receiver as an information display and interactive personal electronic communication device will probably bring dramatic changes to the way our lives are conducted at the office and in the home. The effect will at first be most apparent in business with the easy availability of computer stored information and the ability to send and receive mail electronically. The effect will then become apparent in the home. It is expected that the TV set will gradually enhance its primary role of entertainment device to incorporate information acquisition, computer aided education and electronic message transmission. At an international conference and exhibition on Viewdata held in London in March 1980 the British Post Office demonstrated a useful enhancement to the current PRESTEL service. This was the facility to transmit not only alphanumeric and a mosaic form of graphics, but also still colour pictures.

The problems that exist when incorporating a pictorial mode are those of transmission time and storage. A full 625-line colour picture would require about 4Mbit of storage at the receiver and take about an hour to transmit. While such a storage requirement is costly but practical, the transmission time is clearly unacceptable. Both storage and transmit time requirements can be reduced by limiting the area of the picture transmitted to about one-ninth of the display area. The remaining area can be used to transmit information in alphanumeric mode to provide text about the picture. Investigations are continuing at the Post Office Research Centre at Martlesham into more efficient data compression techniques for the picture data - see Clarke (1980, Ref. 10).

The fourth television channel announced by the Government in May 1979 will be controlled by the Independent Broadcasting Authority. Educational programmes are to be allocated 15 per

cent of the output from this new channel according to Croston (1980, Ref. 11). The broadcasting authorities are looking at a wide range of broadcast and allied media which could have an impact on education in the future. According to Wood (Ref. 6) these include:

- (1) a radio version of ORACLE - 'Radiotext',
- (2) a more extensive Teletext service using a complete television channel,
- (3) a high definition TV display system,
- (4) large flat-screen television displays (micro-electronic developments will remove the need for cathode ray tube displays),
- (5) holography for 3-D television,
- (6) the use of glass-fibre cables for carrying TV signals, and,
- (7) still picture plus sound programme services.

Wood, an advocate of self-paced learning, suggests that interactive text systems will eventually be the most powerful tool in the teacher's stock.

7.6 MEDIA CONSIDERATIONS

7.61 Introduction

The future increase in capacity and decrease in cost of microelectronic devices will give rise to compact and powerful information carriers.

Technological advancements in relation to the storage, retrieval and use of information have, over the last two decades, tended to compress the size of information carriers. They now occupy ever smaller space for storage and distributive purposes. Another trend is to increase the selectivity of retrieval so that fewer pieces of unwanted information have to be scanned and discarded before the item sought is located. When computers first emerged in the 1950s and early 1960s the most widely used

medium was the punched card. Users had to code information prior to having the cards punched. The punched holes in the card represented a number or character. The results would be printed out for the user some time later. Using the unit record concept (one card per item) a typical stores inventory could contain 30,000 punched cards which would occupy an entire punched card filing cabinet. By the early 1960s this card file could be stored on one 10" reel of magnetic tape occupying no more space than a book on a shelf. Then teletypewriter computer terminals appeared consisting of a keyboard and a paper roll. These terminals could be linked directly to a computer to give a so-called on-line link between the user and the machine. Teletypewriters were slow and cumbersome and were largely superseded by visual display units (VDUs) which can be linked to an associated printer or computer store. Finally, in the last few years microprocessors have been incorporated into VDUs to create so-called intelligent terminals. These can independently perform functions like checking for errors in information being typed into the VDU. Ultimately, users will be able to speak to computers but current audio response units have a very limited vocabulary.

The increase in computational power and memory for a fixed price has been approximately exponential over time according to Lipson (1980, Ref. 13). Cost effectiveness doubles every two years. This means, for example, that the cost effectiveness of computing has increased by more than a factor of a million since World War II. It is expected that this doubling will continue through the 1980s. Because computer cost effectiveness will double every two years, Lipson suggests that by the end of the decade devices will be about 30 times more powerful than their equivalents today. One very important technology for educational computer applications in the 1980s will be the videodisk. This will have a tremendous impact on information storage and retrieval capability and is described below.

7.62 The Multi-media Capability of Videodisks

The videodisk developed by Philips Industries (Ref. 14) and currently being marketed in the USA provides a huge (read only) memory capability. A single videodisk about the size of a

long-playing record can store 108,000 television picture frames. The frames can be considered as independent colour pictures (a collection of slides) or as elements of a motion picture sequence. If the 108,000 frames are run as a motion sequence, the disk can store a one hour motion picture. The two modes can also be mixed. One can have a mixture of still frames and motion sequences. It is claimed that transmission of picture and sound are equal to the best available broadcast TV reception and superior to home video playback. The videodisk player is quickly and easily attached to the antenna terminals of any television receiver and is said to be as easy to operate as a conventional music centre. The disk is very durable. The plastic coating protects the videodisk from dust or fingerprints and the laser beam technology used eliminates the surface scratches possible with conventional audio disks. Licklider (Ref. 15) suggests that the cost per frame for videodisk systems is about 100 times cheaper than printing. Thus the economics of the videodisk for educational publishing is expected to become attractive during this decade.

Another development which will have great significance for CAL in the 1980s is the development of the intelligent videodisk (a microcomputer combined with a videodisk) - see Kenward (Ref. 23). This is discussed below.

7.63 Development of Intelligent Videodisks

In September 1979 IBM announced a joint venture with the developers of the videodisk (Philips Industries and Music Corporation of America (MCA)) to enter the microcomputer market. The logical capability of a microcomputer combined with a videodisk may make possible interactive lessons combining a variety of media. Lipson (Ref. 13) suggests that the creative elements of colour, motion, animation, line drawings, multiple sound messages, and computer modified graphics are feasible with such a combination. He also queries whether humans whose creative patterns are based on the limitations of existing media can respond to the new opportunity.

7.64 The Economics of Media Considerations

In looking at cost factors, plastic discs for audio and, in the future, video recording are less expensive in materials than audio and video cassettes. Fothergill (Chapter 2, Ref. 6) believes that they are likely to remain so for media mass marketing. The price of materials and associated equipment is dependent on the size of the domestic market. This is, of course, influenced by the extent of the use in the home environment. By comparison, educational institutions, public libraries and even business houses are an insufficient market to make a major impact on the price of materials and equipment and the size of the production line.

The importance of the home environment has also been stressed by Luehrmann (1980, Ref. 16). He thinks people in school systems view educational technology as a threat rather than as a way to improve the quality of the learning environment. He suggests:

- (1) The need to explore ways of introducing educational computing through non-school institutions such as the home, the museum, the library and the workplace.
- (2) The requirement of devising 'non-threatening' technology for school use.

It is believed that small, low-cost intelligent videodisk terminals would be flexible and unthreatening enough to be compatible with the present character of teachers and scholars.

The widespread use of computers as suggested above will, it is expected, generate a computer-related curriculum since schools will increasingly feel the need to offer one.

The CET (Chapter 5, Ref. 14) also emphasise the importance of the home environment. They suggest that the general public will expect teaching and learning systems to keep pace with developments in microelectronics experienced in commercial and domestic life. Consequently, people will want 'home-learning'

programmes appropriate to a microelectronic age in that they are cheap, easy to use, reliable and versatile.

7.7 CONVERGENCE OF INTERESTS - THE NEED FOR TOTAL INTEGRATION

7.71 Introduction

In earlier sections the future impact of large mainframe computers, minicomputers and microcomputers on CAL was discussed. It was shown that the types of computer used for CAL will continue to be quite variable. Added to this will be the versatility of computers enabling them to interact with viewdata systems and advanced storage systems such as the videodisk. It is anticipated that progress will continue to be made in all media through research and development and the quality of the reproduction of the message will improve as a result. This section will examine the need for total integration of all communication resources to provide a multi-media data base.

7.72 Definition of a Multi-Media Data Base

A data bank or data base may be thought of as a comprehensive collection of libraries of data. The American National Standards Institute (Ref. 17) has defined data as a 'representation of facts, concepts or instructions in a formalised manner suitable for communication, interpretation or processing by humans or by automatic means'.

In accord with this view a data base may be defined as a 'stored collection of data/information plus appropriate mechanisms for accessing and manipulating the data in a controlled way'.

Accessing facilities will provide the means by which users of the data base may retrieve stored items or details about those items. Updating facilities will provide the means by which new data/information may be added to the data base. In addition, techniques must exist to enable stored items to be manipulated in

various ways. Manipulation may include changing or modifying an item or removing (deleting) it from the storage system. A data base, as will be discussed later, is a tool that is available to aid the process of communication.

7.73 **Types of Information contained in the Data Base**

It is suggested by Barker and Yeates (1980, Chapter 1, Ref. 10) that, essentially, there will be three types of information stored within the data base system:

- (1) Material that is to be transferred to some recipient during a message transfer period - called 'internal resources'. These may consist of CAI instructional sequences, factual information to be disseminated via some type of HELP system, tables of results acquired by some research process (for example, sales figures), or digitised pictures stored on microfilm.
- (2) References to material that is not contained (that is stored directly) within the data base but which is to be used as part of the overall communications strategy. These are called external media. Within the data base, pointers to the external media direct the potential users of these materials to their actual source or location. Thus, the data base may contain pointers to an externally stored slide collection, a set of photographs, some mechanical model of a real life situation, or an establishment such as a library, museum or university.
- (3) Performance data and control information. These are important for the following reasons:
 - to enable the designer to assess the effectiveness of the system he designs,
 - to control the import and export of materials to and from the data base system,
 - to monitor and control the mobility of the materials (both internal and external) if chaotic distribution problems are to be avoided,

- to change and/or update stored materials,
- to minimise the possibility of loss or damage,
- to specify who may have access to the stored material, and
- to determine what charging rate(s), if any, are to be levied for a particular user.

The division between what is stored internally within the data base and what is stored externally is not well defined. The dividing line depends to a large extent on the state of technological advancement that is current at the time of system implementation. Thus, at one particular period of time technology might dictate that a slide collection be stored as an external resource associated with the data base. However, at some later stage that storage media decision might point in the direction of storing the slide collection on a videodisk. It would thereby become a part of the internal resource repertoire of the system. Similar arguments apply to most of the other external resources indicated in Figure 7.2. However, there would be certain types of resource which would never become part of the internal resources of the machine. Libraries and museums are particular examples of such resources. Simulation of a particular situation in a library or a museum through the use of multi-media resources is now technologically possible. In a project called DATALAND, the Massachusetts Institute of Technology (Ref. 12) provides a multi-media environment in which vast and varied data banks can be explored. This is described below.

7.74 'DATALAND' - An Example of a Multi-Media Data Base

The 'DATALAND' project is funded by the US Department of Defence with the aim of improving the interaction between people and computers. Experiments are being conducted at the Massachusetts Institute of Technology (MIT). In these experiments the user sits in a chair equipped with an aeroplane-type joystick, special touch sensitive pads and zoom focus controls. On each side of the chair is a small VDU and in front of it a large wall display. Using the joystick, the user navigates through various 'Datalands' on the small screen, -each of

TYPICAL INTERACTIONS IN A MULTI-MEDIA DATA BASE SYSTEM

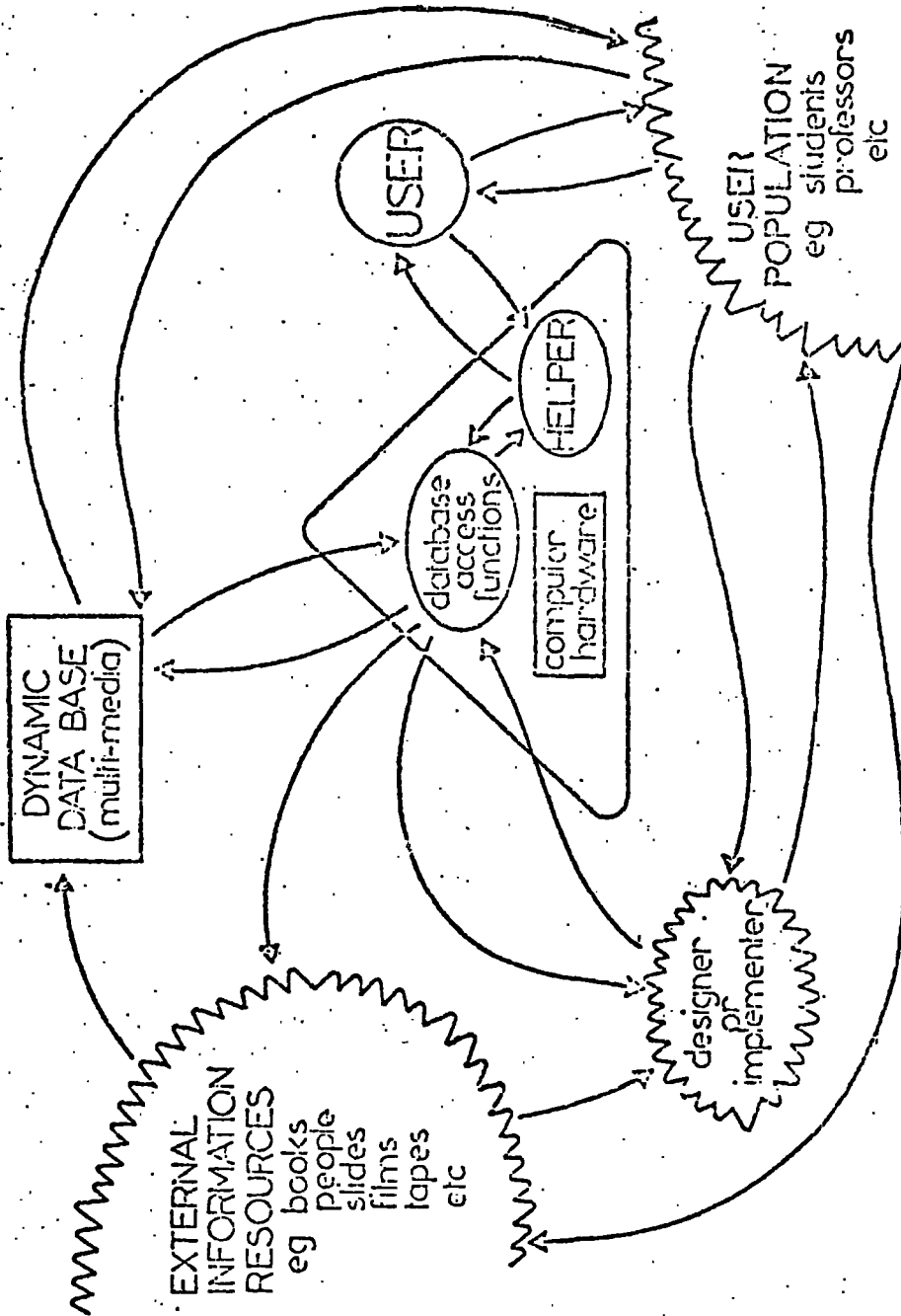

Figure 7.2

which has a theme. These could be personnel photographs, information libraries or satellite maps of a particular area. Once in a Dataland, details of the information in that "data space" are projected on to the large screen and the user can zoom into more and more detailed information. From an overall satellite picture, a particular city can be picked out, then detailed street maps. Using videodisks and digital computer storage techniques the user can obtain a file of the city, a slide show or just factual information. Another data space has pictures of individuals. It is possible to focus on particular photographs and ask questions about that person with answers coming from computerised data associated with the photograph.

The concept of a multi-media data base thus embodies the idea that a wide variety of non-book materials should be made available to assist the communication process between the donor (or source) of a message and the recipient of that message. Figure 7.2 shows the way in which a multi-media data base system might aid the interaction of those wishing to become involved in some form of communicative encounter.

7.75 The Need for the Multi-Media Data Base to be Dynamic

Those wishing to communicate constitute the user population of the data base (for example, teachers and students, a group of research workers or a training officer with a group of employees). The person responsible for analysing and formulating the requirements for the overall system is referred to as the designer in Figure 7.2, while the implementer is the person responsible for building the actual system. The designer will need to interact quite closely with potential users of the system and experts in many areas of technology.

Computer hardware/software are important building blocks for the system. These components offer a storage capability into which certain of the multi-media materials may be stored (referred to as internal information sources) and also a communicative resource. In addition, it offers a facility for synchronising and controlling the parallel and sequential use of resources. Not all resources

will be capable of being stored directly within the computer storage system. Such materials that cannot be included are referred to as external information sources. For this type of resource, references to them are stored within the computer system. The data base is called 'dynamic' since it is meant to tune itself to the needs of its user population, storing only that which is necessary and disregarding anything which is redundant. The access functions control the movement and manipulation of stored material; they also contain details of who may access the materials. Often systems such as that being described here contain a 'user friendly' software component designed to provide an easy to use interface to the system. This is often achieved by means of simple natural language-like dialogue facilities that generate instructions on how to use the system and which enable operational queries to be answered. Several examples of the type of dialogue referred to have been illustrated in Chapter 6. This type of component is often referred to as a HELP system or HELPER - see Barker (1979, Ref. 18). Interactions, or communicative pathways, and data/information flows are depicted in the diagram by means of arrows. The type of component hardware/software and multi-media equipment required for the implementation of such a system will obviously depend upon a wide variety of factors that include the user population for which the system is designed and the types of communication channel that the system is to encompass.

Figure 7.3 shows one type of 'hardware' configuration and the types of multi-media resources that have been described in earlier chapters.

7.76 The Nature of the Message Creation Process

In Chapter 1 an attempt was made to establish the purpose of communication - broadly to influence the behaviour of some entity. This could be a social group, a student, a motor car, a manufacturing company, a computer a country! The types of communication channel and the possible benefits that might arise from the use of a multi-media approach to communication were discussed. In this chapter some suggestions have been made

EXAMPLE OF A MULTI-MEDIA DATA BASE SYSTEM

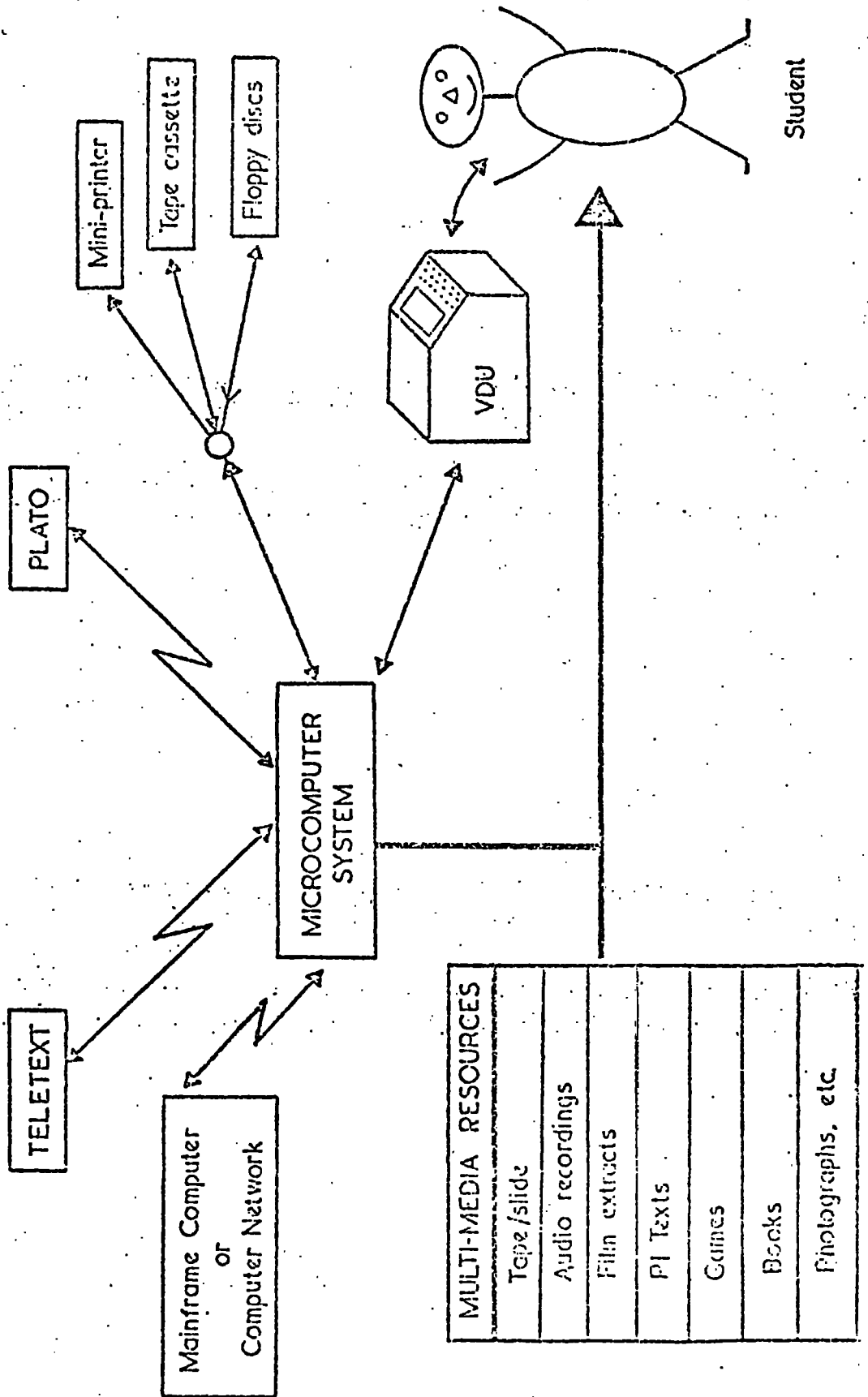

Figure 7.3

regarding the types of material that might be contained in a multi-media data base.

In this section the message creation process will be examined in more detail. The nature and relationship of the processes that are triggered when an entity A wishes to communicate with some entity B are many and complex. Figure 7.4 represents an approximation of the types of steps and processes that are involved.

Consider the case in which the donor entity is a human wishing to pass a message to another human or human group.

The entity A draws upon his own stored knowledge in order to find the means of expressing the message. This could entail the selection of appropriate words, phrases, gestures and facial expressions. He may then turn to books, technical journals, libraries, diagrams, picture slides, or animation techniques to find additional data/information to express the message appropriate to his purpose. During this phase of the communication task, the donor is drawing upon collections of stored materials from a wide variety of sources. This constitutes a retrieval process. After examination it might be found that some of the material collected during the retrieval process might be unsuitable. Careful analysis and refinement enables the creation of a 'temporary resource store' of materials that will probably be used in constructing the message to be transmitted. These operations constitute a selection process. Sometimes the material he requires will not be contained in the system. Consequently the donor may now need to produce the necessary material to enable the transfer of his message. For example, the 'message' may be a sales talk to promote a new product, a lecture to a learned society giving projected trends in a particular subject area, or a set of instructions to perform a task.

The generation of new material is referred to as a creation process and may be influenced by the 'temporary resource store' and by a host of environmental factors which usually form the basis of the entity's 'need to communicate'.

THE MESSAGE CREATION PROCESS

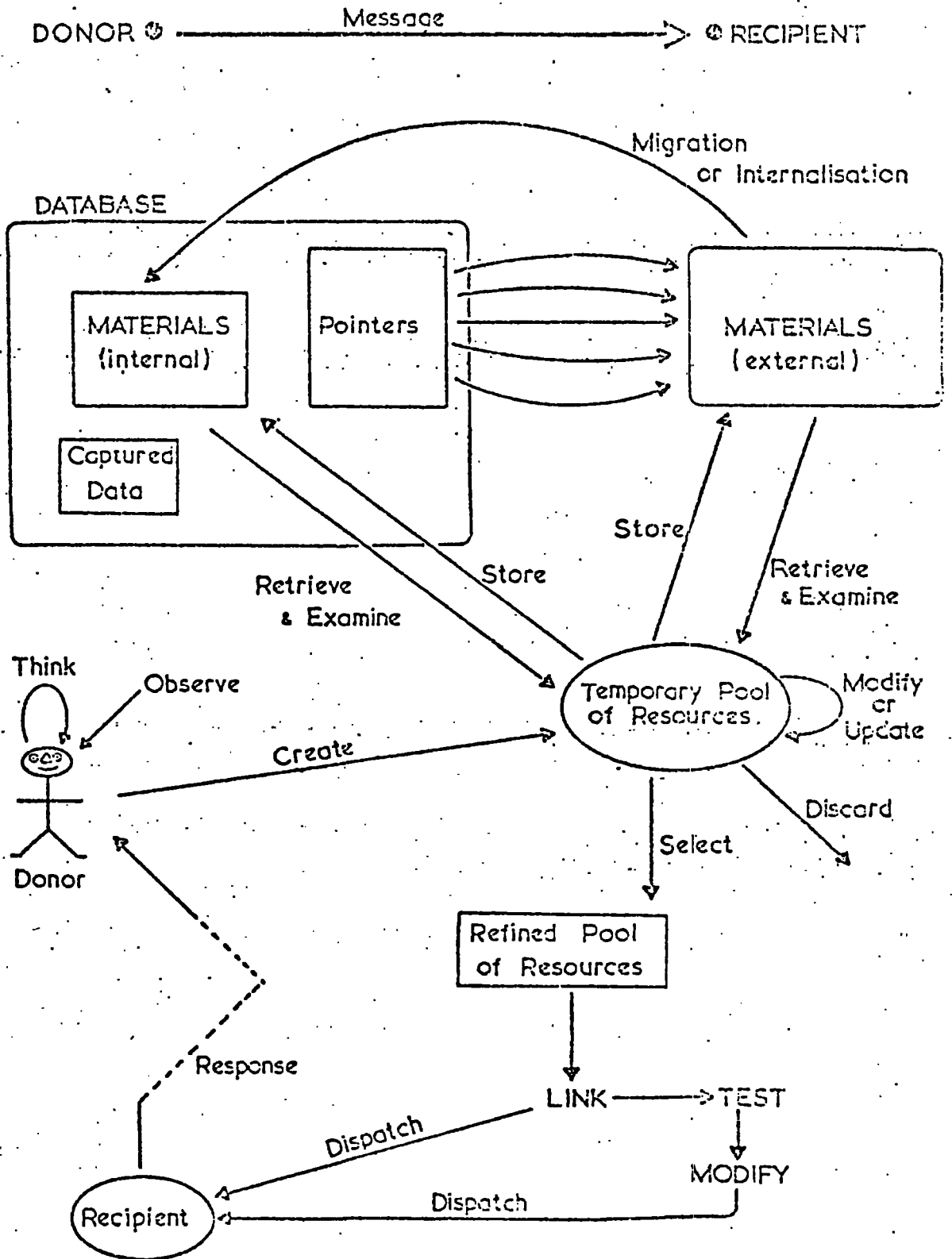

Figure 7.4

New materials that are produced via the creation process may ultimately need to be stored for future use. This requirement will necessitate the availability of various storage processes. Retrieved materials may need to be changed to correct any errors or update them. The ease of implementing the updating process associated with this type of activity will depend upon the nature of the materials involved and whether these are held in the internal or external store.

When the communicating entity has gathered together all the temporary resources that are needed for the actual creation and despatch of the message, the various items involved are linked together. These might then be tested via appropriate simulation facilities and then despatched. Often it will be necessary to analyse the effect the message has on the recipient group, and, if necessary, modify the message sequence before it is (possibly) re-transmitted. This latter activity constitutes a process of refinement.

7.77 The Role of the Computer

Earlier chapters have described the need for appropriate computational facilities. These are of major importance to the design and implementation of a multi-media data base system. The following list presents a summary of the role that the computer has to play:

- (1) As a communication medium - as in CAL, electronic mail or HELP systems.
- (2) As a data base processor and storage medium containing stored materials to aid communication.
- (3) To increase the interactivity of otherwise non-interactive media.
- (4) As a synchronisation tool to coordinate activities with respect to the use of multiple channels.

- (5) For simulation and planning the content of a message sequence.
- (6) To help the communicator create new materials in order to aid his task of communication.

Earlier examples of CAL applications have illustrated that the type of computer used in the system will be quite variable. It has been shown that large mainframe, mini and micro computers each have significant parts to play. Multi-media systems show many of the attributes of a distributed system. The microcomputer will act as a local highly responsive processing element used to coordinate local peripherals attached to the system. The role of the mainframe(s) will be to act as remote large capacity stores (back end data base processors) of material and be able to support developmental work. Minicomputers can, and are being used in either role.

7.78 Interactions arising in a Multi-Media System

Figure 7.2 was used to illustrate some of the logical interactions that are likely to occur in a multi-media data base system. Based upon what has been presented in earlier chapters, Figure 7.5 illustrates some of the interactions that could arise in an actual realisation of the data base system presented in Figures 7.2 and 7.3. The diagram reflects many of the components which are included in present experiments or which it is intended to include in future work. The type of system that is being proposed is highly distributed and its construction is technically feasible. In Chapter 6 a description of the use of the computer to increase the interactivity of a synchronised tape/slide presentation (MODE 2) and conventional lectures (MODE 3) recorded on tape cassettes was given. In all cases, appropriately programmed man-computer dialogue is used to substantially increase the interactivity of the communication process by letting the recipient respond to the information that he receives. Other interfaces through which system interactions take place are currently being designed or are in the process of development.

COMPLEXITY OF INTERACTIONS IN A TYPICAL MULTI-MEDIA DATA BASE SYSTEM

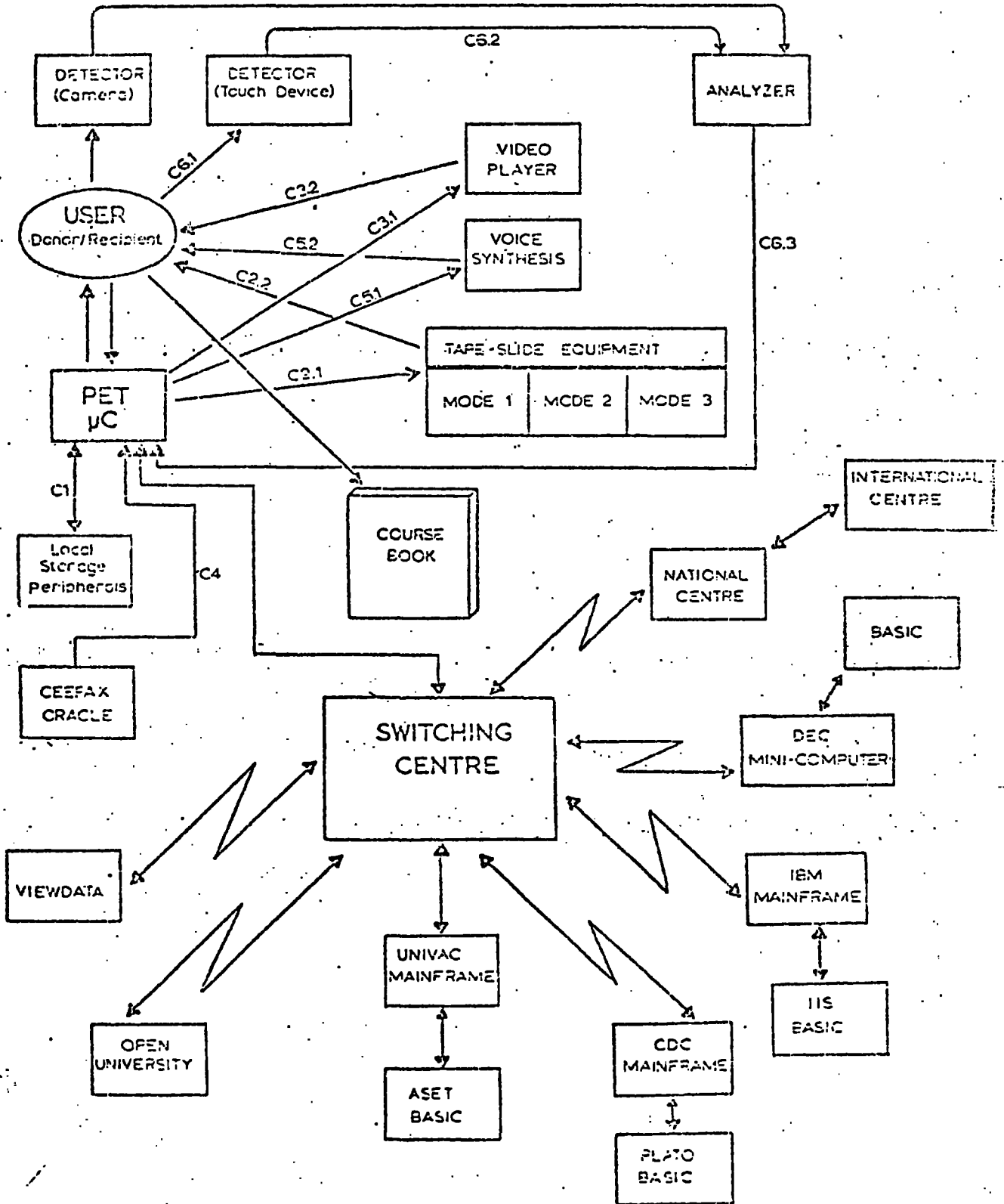

Figure 7.5

Thus, C4 for example, the interface between the microcomputer and the teletext TV (CEEFAX and ORACLE in the UK) is one which will enable the user of the system to control the display of received information through the use of the keyboard on the microcomputer. This replaces the numeric keypad which is normally used.

The microcomputer is able to activate the TV set when it is required and then select the pages of information that are specified by the user through his terminal dialogue with the system. If necessary, the user can copy the contents on a hard copy device for future reference.

Other interfaces currently being designed include an inexpensive 'touch sensitive' screen (C6) and a sonic output channel (C5) based upon a voice synthesizer chip. These interfaces will permit quite sophisticated interactions to be implemented.

7.79 The Data Base Processor

The function of the data base processor will be many fold. However, from its users' point of view (both communicator and recipient) it will serve the purpose of servicing requests for information posed in the form of suitable questions. Typical questions might be:

Is there any stored material on topic X?

What types of material exist for topic X?

Are there any slides or transparencies on topic X?

Is there a photograph or wall-chart to illustrate
concept X?

Is there a recorded lecture or audio/visual
presentation on topic X?

List the titles of slides on topic X.

Who owns the transparencies on topic X?

Are there any teletext frames on topic X?

Who has the film on topic Z?

etc.

etc.

Recently there has been an important development which could mark the beginning of a national information system for teaching and learning materials. The British Library has put catalogue entries for over 5000 items of audio-visual materials into its computerised on-line information service. These entries are printed in the first experimental edition of what is expected to become a permanent feature in this field - the British Catalogue of Audio-Visual Materials (BCAVM) (1980, Ref. 19). The items include filmstrips, slide sets, overhead projector transparencies, sound cassettes, film loops, multi-media packs and other non-printed materials.

The first experimental edition was the direct result of the British Library and Inner London Education Authority Learning Materials Recording Study. This project, funded by the Research and Development Department of the British Library, ran from 1977-1979. It concentrated on conversion of a section of the catalogue of the ILEA's Central Library Resources Service Reference Library into machine-readable form as a first step towards developing a national data base of audio-visual materials. It is these records that form the basis of this catalogue although information on a small number of 16mm films has been contributed by the British Universities Film Council. A number of publishers also provided information on their new products. The catalogue contains a classified subject index giving full descriptions of approximately 5200 items arranged by the Dewey Decimal Classification scheme. There is a detailed subject index and an index of titles, series, people and organisations responsible for the creation of material and also an address list of publishers and distributors. By paying a small subscription, computer access to BCAVM is available. All that is needed is a computer terminal, a telephone and an acoustic coupler to obtain access to the British Library Automated Information Service (BLAISE). Recent revision of the UKMARC format in the context of the second edition of the Anglo-American Cataloguing Rules takes full account of the integrated treatment of non-book materials in the rules. The modifications include a field for information about physical characteristics, using a six-character faceted alphabetic

code. This permits detailed searching on BLAISE for a specific physical form in addition to the use of the standard search qualifiers. For example, searching is possible on the following, separately or in any combination:

Audiotape, type of container (reel, compact cassette, etc.), tape width, number of tracks, mode (mono, etc.), speed of recording

In addition it is possible to perform complex subject searches by combining index terms.

Further development work on the data base with support from the CET is continuing, and a supplement to the original catalogue is to be issued in 1980.

One of the major functions that a multi-media data base should be capable of performing is to enable the communicator to reconstruct, recall or recreate the communication sequences used in any particular communicative encounter. This will necessitate the design of quite sophisticated data and storage structures that describe the type of media used and the various relationships between them. Some of the important elements of data/information that the system will need to store and be capable of processing are illustrated in Figure 7.6 as a 'Communication Packet'.

The transmission data will contain the material to be transmitted along with the sequencing, timing and presentational details. The supporting data will consist of all the ancillary material needed to support the items used in the communication packet, for example, authors/originators of material, costing information, and construction details.

When a user interacts with the system the interaction could proceed along the following general lines:

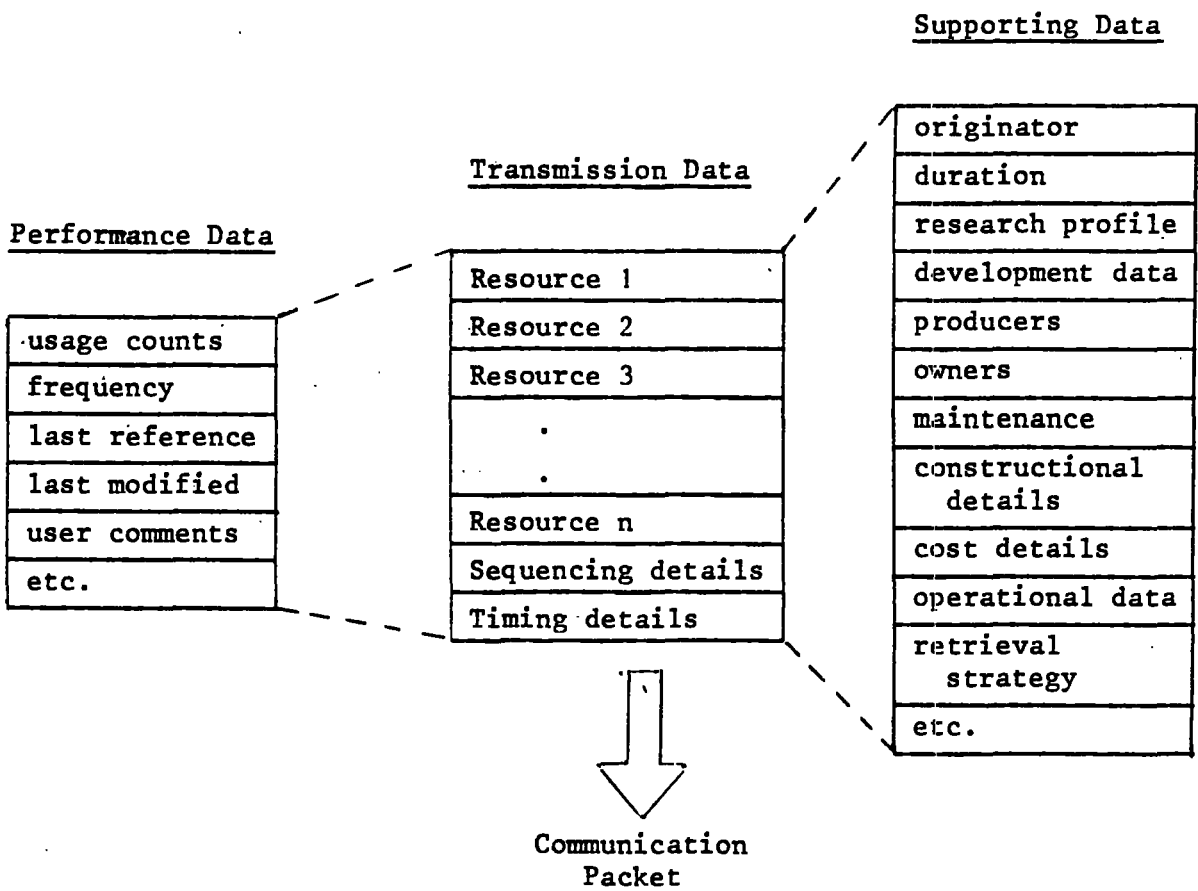

Figure 7.6

- Step A: Initial Dialogue - attempts to locate what he wants,
- Step B: Transportation of Materials - to local peripherals, for example, slide sequence, supporting audio tape, supporting CAL software on tape or disk,
- Step C: Loading of Materials,
- Step D: Activation of Systems, and
- Step E: Subsequent Communicative Dialogue.

At present most of the components that are used in communication have to be physically transported and loaded into the system by the user before true communication can proceed. This is shown in the upper part of Figure 7.7 wherein solid lines represent basic interactions between system components and broken lines show user aided material flow. Because of this stage of affairs, the data base will need to contain information not only to support the initial dialogue, but will also enable the user to locate the materials required and then load the appropriate input devices.

As time progresses, as far as the data base is concerned, one of the most important processes that it will need to be able to accommodate is that of internalisation. This was described earlier in Section 7.73 and is now depicted in more detail in the lower part of Figure 7.7.

From a comparison of the two parts of this diagram it can be seen that internalisation removes the need for user-aided transportation processes and therefore reduces the complexity of the overall interaction between the user and the system. Correspondingly, however, the interaction device will become more sophisticated, containing, for example, a high resolution screen that will be able to support both graphic and textual data. It would also have a built-in loudspeaker arrangement for the presentation of sonic information (compare the conventional television set).

THE INTERNALISATION PROCESS

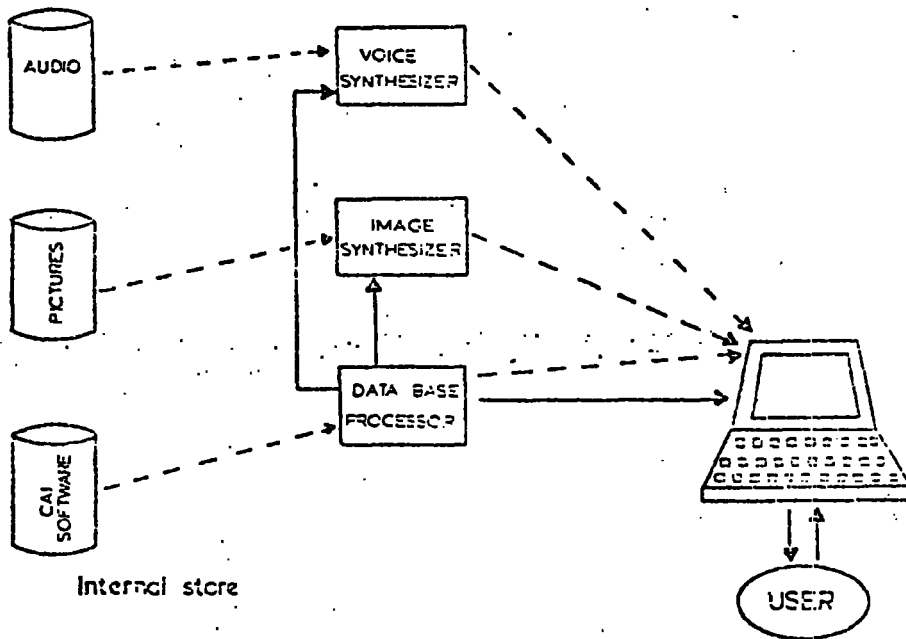
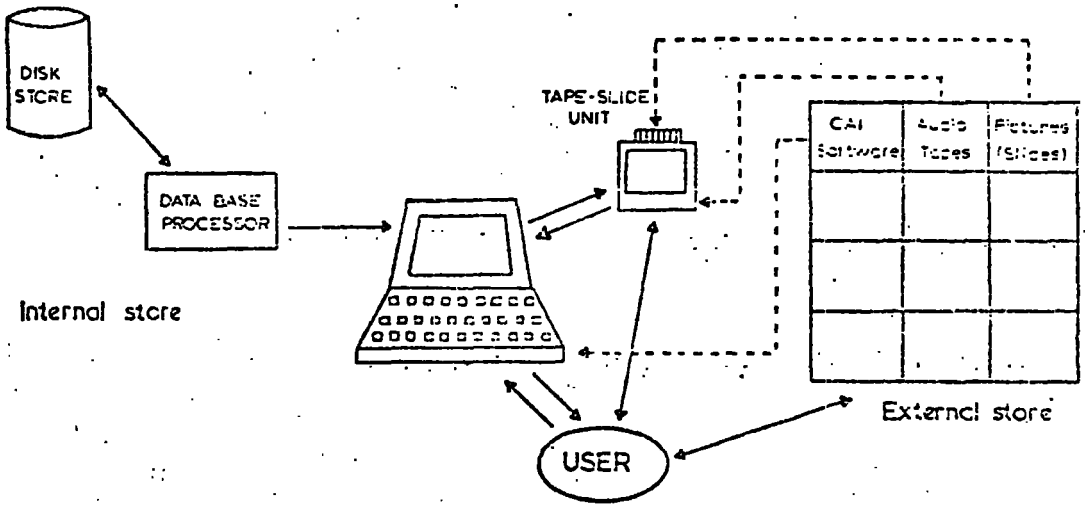

Figure 7.7

Internalisation will affect the data base in several ways:

- (1) It will have a simpler content since much of the user instructional dialogue relating to the location and loading of the materials will no longer be needed.
- (2) Appropriate access mechanisms will replace the above dialogue. These will control equivalent computational processes operating on the materials that are now held within the internal store.
- (3) Facilities to edit sonic and pictorial data will be made available through the available interaction devices. (Previously this editing was performed by 'detached' external processes, for example, making diagrams/slides to replace old ones, editing audio-tapes by copying and re-recording techniques, etc.)

Techniques are now becoming available to enable these processes to be performed via the interaction device. Scenes of pictures stored in digital form within the computer memory will require the capability of being changed or replaced and new pictures synthesized from parts. These would require to have the same appearance and quality as were available through the conventional means of production (video cassettes, slides or film).

One of the major advantages of internalisation is that it places greater control over the previously uncontrolled diffusion of materials that was held in an external store. However, as more material is held internally, a greater variety of storage devices and retrieval strategies will be required. Naturally, internalisation will be accompanied by a corresponding expansion of internal storage capacity of the data base system.

7.8 PROBLEMS OF INTEGRATION

The present state of development in multi-media data base systems is one of rapid evolution and investigation of the applicability of new techniques and procedures. Consequently, the short-term future may well see the solution of many of the problems outlined below:

(1) Problems of Sharing Resources

The difficulty of 'copying' conventional multi-media resources often inhibits their effective real-time simultaneous sharing. For example, a single copy of a slide sequence or audio cassette tape cannot exist in two geographically remote places simultaneously.

(2) Problems of Distribution

Resources that exist in non-electronic form are difficult to distribute with any degree of rapidity. Materials in the form of course books, posters/charts, photographs, slides and tapes cannot be made 'directly' available, thus causing time lags with respect to availability.

(3) Problems of Updating Materials

The difficulty of updating resources that are not stored in electronic form represents a major obstacle to their ease of use. Slide collections, audio tapes (particularly if they contain synchronisation pulses) are very difficult to update. This is also true of cine films and any resource that contains sophisticated artwork.

(4) Problems of Complexity

As the multi-media system becomes more complex by the addition of more channels and storage media, so ease of use becomes a problem. The use of many channels in parallel could overload the receiver's capacity and inhibit rather than enhance learning (see Section 1.31).

(5) Problems of Reliability

Increased complexity as a result of a larger number of components implies the use of more interfaces between these components. The greater the number of devices and interconnecting interfaces, the more room there is for error and hence unreliability.

(6) Coordination Problems

As the number of parallel channels increases, so the problems of smooth 'switchover' increases in magnitude. Accurate timing diagrams that indicate the passive/active nature of the channels (as a function of time) are required to help solve these synchronisation problems.

7.9 CONCLUSION

7.91 Courseware Problems

Courseware is the most important component of any CAL system according to Leiblum (Ref. 20) since that is all that is visible to the user. He argues that many users will not be concerned about the computer or the software supporting the courseware; they only serve as delivery vehicles. If the term 'courseware' is taken to mean the wide range of multi-media instructional materials (still and moving pictures, audio recordings, etc.) described in this thesis the author would agree. However, the term is more frequently used in a much narrower way to include merely computer assisted textual presentations.

It has been shown in earlier chapters that CAL can serve almost every curriculum area in education, commercial, military or industrial training. Probably the more important question is how it can serve.

Courseware can be divided into two classifications, the type that supplements traditional instruction, sometimes called the 'adjunct' type, and the type that replaces it (often called 'mainline').

Using CAL to replace traditional instruction - not the teacher whose role only will be changed - poses considerably greater problems than in using CAL merely as a support. Mainline CAL requires a far greater financial investment and a complete redesign of the existing instructional system. These are both major hurdles especially in today's stringent financial climate. One of the most frequently heard arguments against CAL is that it is an expensive plaything. Clearly CAL materials should be developed which could not be presented more cheaply by using other instructional media. Another problem with courseware is the question of who should develop it. While some teachers may find it exciting and pleasurable to develop a program product from start to finish, it is more likely that the majority would want to spend their time developing the subject content and leave the programming to others.

Both Leiblum (Ref. 20) and Rushby (Chapter 2 Ref. 3) suggest that authors of good teaching materials, whether or not they are based on CAL or some other media, are not given encouragement and some have to work in an environment adverse to technological change. Clearly, some kind of reward is needed to motivate and encourage the teacher/author.

7.92 Probable Developments of CAL in Higher Education

The future of instructional computer use will be determined by the interaction of many influences, both educational and technological. Levien et al (Ref. 1) suggests that perhaps the dominant influence will be the changes taking place in higher education under social, economic and political pressures. The institutions of higher education forged by these pressures will likely differ from the present ones in their sources of support, clientele and governance. They will also differ in the way they structure their programmes. It is expected that the wider use of computers in education will facilitate certain of the major directions of reform. These are listed below:

(1) Open access to and wide availability of instruction

The norm is for students to apply for admission to higher education and each institution selecting its students from among its applicants. Every person has a right to higher education and it is expected that more organisations like the Open University will cater for this need.

(2) Individual choice of materials and mode of instruction

Education is likely to be received in a variety of places, including the home and place of work. Attendance will not be restricted to a continuous interval of three or four years. Topics will probably be pursued at the rate and for the length of time appropriate to the student's needs. Instruction will continue (at any age) until proficiency is reached.

(3) Organisation of Instruction

Extensive computer use is likely to force certain changes in the organisation of instruction. Students are likely to learn on an individual basis as well as in groups. There will be more self-paced learning. Divisions among courses will not be so rigid and the nature of examinations will probably change. The number of years of learning needed to acquire a certificate or diploma may vary widely and it is unlikely that students will be dismissed from higher education for academic reasons.

However, the high resistance to change of most existing institutions of higher education is recognised. It is suggested that the most rapid and extensive adaptation to the capability of CAL is likely to occur in institutions intended to serve populations not enrolled full time in conventional institutions.

REFERENCES

- (1) Levien, R.E. and Blackwell, A., Technology of Computer Uses in Instruction, In Levien, R.E. (ed), The Emerging Technology: Instructional Uses of the Computer in Higher Education, McGraw-Hill, New York, 1972
- (2) Hewlett-Packard, Time-Shared Systems Expand Scope of Education, Educational Consortium, Application Note 145-11, July 1972
- (3) Webster, R., Simpler Aid is Son of PLATO, Datalink, September 1980
- (4) Fedida, S. and Dew, B., Viewdata in Education, in Handbook of Educational and Instructional Technology, 1978/1979
- (5) Independent Broadcasting Authority, Telesoftware from ITV ORACLE: A Broadcast Computer System using ITV's Teletext Service, Engineering Information Service Ref. 140/2, February 1980
- (6) Wood, D., Media A La Carte: A Survey of Media Technology in the Service of Educationalists in the Years Ahead, IBA Engineering Information Service, February 1979
- (7) Kenward, M. (ed), Computerised Teaching Takes Off in Canada, New Scientist, July 1980
- (8) Purvis, J., Prestel to Help Remote Pupils, Datalink, August 1980
- (9) Turner, S., Combining Viewdata and the Home Computer Terminal, Philips Research Laboratories, Redhill, Surrey, 1979
- (10) Clarke, K., Prestel Development Strategy, First World Conference on Viewdata, Videotex and Teletext, London, March 1980
- (11) Croston, E. (ed), Television and Radio 1980: Guide to Independent Television and Independent Local Radio, IBA, London, 1980
- (12) Kenward, M. (ed), Take a Lesson from a Machine, New Scientist, 22 November 1979
- (13) Lipson, J.I., Technology in Science Education: The Next Ten Years, National Science Foundation, Computer, July 1980
- (14) Philips Industries, Technical Data on the Diode Laser Optical Recording System, Philips Data Systems B.V., PO Box 245 Apeldoorn, The Netherlands, November 1978
- (15) Licklider, J.C.R., Impact of Information Technology on Education in Science and Technology, Science Education Directorate, National Science Foundation, Washington D.C., 1979
- (16) Luehrmann, A., Technology in Science Education - Perspectives and Recommendations, Science Education Directorate, National Science Foundation, Washington D.C., 1979

- (17) American National Standards Institute, Standard X3.12, Vocabulary for Information processing, 1970
- (18) Barker, P.G., HELP Systems as an Aid to the Teaching of Software Engineering, Paper presented at the CAL '79 Symposium, University of Exeter, 4-6 April 1979
- (19) British Library, The British Catalogue of Audio-Visual Materials, London, 1980
- (20) Leiblum, M.B., A Pragmatic Approach to initiating a Computer Assisted Instruction Service and some Problems involved, Katholieke Universiteit, Nijmegen, Netherlands
- (21) Barker, P.G., Development of an Individualised Multi-Media Computer Based Learning Centre, Project proposal to Council for Educational Technology, April 1979
- (22) Barker, P.G., An Investigation into the Use of an Author Language for Computer Assisted Learning using Microcomputers, CNA A Higher Degree Research Proposal, August 1980
- (23) Kenward, M. (ed), IBM Thinks Small on Computers, New Scientist, September 1979

